

Caterpillar Performance Handbook

46

CATERPILLAR[®]

CONTENTS

	Page
Preface	4
Environment and Sustainability . . .	4
Operator and	
Machine Protection	5
Operator Training	5
Machine Modifications	7
Equipment Options	7
Machine Protection	7
Fire Prevention	7
Safety Regulations	8
Sound Suppression	8
Replacement Parts Warning . .	8
Nomenclature	9

ARTICULATED TRUCKS	1
BACKHOE LOADERS	2
DRILLS	3
ENGINES	4
FOREST PRODUCTS	5
HIGHWALL MINING SYSTEM	6
HYDRAULIC EXCAVATORS – Front Shovels • Hydraulic Excavators	7
HYDROMECHANICAL ATTACHMENTS	8
MATERIAL HANDLERS	9
MINING & OFF-HIGHWAY TRUCKS	10
MOTOR GRADERS	11
ON-HIGHWAY TRUCKS	12
PAVING PRODUCTS	13
PIPELAYERS	14
SKID STEER LOADERS • MULTI TERRAIN LOADERS • COMPACT TRACK LOADERS	15
SURFACE MINING EXTRACTION – Draglines • Electric Rope Shovels • Hydraulic Mining Shovels	16
TELESCOPIC HANDLERS	17
TRACK LOADERS	18

CATERPILLAR PERFORMANCE HANDBOOK

a publication by Caterpillar, Peoria, Illinois, U.S.A.

JANUARY 2016

Performance information in this booklet is intended for estimating purposes only. Because of the many variables peculiar to individual jobs (including material characteristics, operator efficiency, underfoot conditions, altitude, etc.), neither Caterpillar nor its dealers warrant that the machines described will perform as estimated.

NOTE: Always refer to the appropriate Operation and Maintenance Manual for specific product information.

Materials and specifications are subject to change without notice.

CAT, CATERPILLAR, SAFETY.CAT.COM, their respective logos, "Caterpillar Yellow" and the "Power Edge" trade dress, as well as corporate and product identity used herein, are trademarks of Caterpillar and may not be used without permission.

TRACK-TYPE TRACTORS	19
UNDERGROUND MINING EQUIPMENT – Hard Rock • Longwall • Room & Pillar	20
WASTE HANDLING	21
WHEEL DOZERS • SOIL COMPACTORS	22
WHEEL LOADERS • INTEGRATED TOOLCARRIERS	23
WHEEL TRACTOR-SCRAPERS	24
ESTIMATING OWNING & OPERATING COSTS	25
FORMER MODELS	26
LAND CLEARING	27
MINING AND EARTHMOVING	28
STOCKPILE COAL HANDLING	29
TABLES	30
TECHNOLOGY PRODUCTS	31
TIRES	32

PREFACE

Machine performance must ultimately be measured in unit cost of material moved, a measure that includes both production and costs. Factors bearing directly on productivity include such things as weight to horsepower ratio, capacity, type of transmission, speeds and operating costs. The Performance Handbook considers these factors in detail. There are other less direct machine performance factors for which no tables, charts or graphs are possible. Serviceability, parts availability and operator convenience are examples. In comparing machine performance, all factors should be considered. This Handbook is intended as an aid which, when coupled with experience and a good knowledge of local conditions, can assist in estimating true machine performance.

Many sections of the Handbook include tables or curves showing cycle times or hourly production figures for Cat® machines under certain conditions. Statements of conditions always accompany or precede the curves or tables. Before using any performance information in this Handbook, a complete understanding of the qualifying conditions is essential. The data is based on field testing, computer analysis, laboratory research and experience; and every effort has been made to assure their correctness.

However, all such data is based upon 100% efficiency in operation — a status which cannot be achieved continuously even under ideal conditions. Thus, in using such performance and production data, it is necessary to correct the results indicated in the handbook tables by appropriate factors. This allows for the anticipated actual job efficiency, operator efficiency, material characteristics, haul road conditions, altitude and other factors which may reduce performance or production on a particular job.

Methods for estimating machine owning and operating costs vary widely, depending on locality, industry practices, owner preferences and other factors. One method is suggested in the Handbook section on Owning and Operating Costs. When used with good judgment, it has provided reasonably accurate estimates in the past. Included in the Owning and Operating Section are guidelines, based on working conditions, to assist in estimating consumption of fuel and lubricants, tire life and repair costs for Cat machines. However, what one Handbook user regards as “excellent” conditions, another may consider “severe” or “average”, depending on his own experience and basis of comparison. Therefore, these guidelines should be considered only approximations.

Caterpillar has made every effort to assure that the information contained in this Handbook is accurate and is a fair statement of the results to be achieved in the circumstances indicated. However, because of the many variables involved in estimating the production or performance of earthmoving machinery, their consumption of fuel and lubricants, tire life and repair costs, and the possibility of inadvertent errors or omissions in assembling this data, Caterpillar cannot and does not imply that all data in this book are complete nor that this level of performance will be achieved on a given job.

Specifications shown in this Handbook were current at time of printing. However, due to Caterpillar's many machine improvement programs, specifications and materials may change without notice. For current specifications relating to a machine's performance, please refer to the most recent Cat product specification sheet.

Caterpillar

ENVIRONMENT AND SUSTAINABILITY

Caterpillar supports environmental responsibility through sustainable development. Our products and services are intended to support sustainable development of global resources and they will meet or exceed applicable regulations and standards wherever they are initially sold. We establish and adhere to environmentally sound policies and practices in product design, engineering, and manufacturing. We educate and encourage

our customers to use the products they purchase from us in environmentally responsible ways. We take effective steps to continually increase the natural resources efficiency and cleanliness of our facilities. When available, the various product groups have included relevant sustainability data with their content updates for inclusion in the Performance Handbook.

OPERATOR AND MACHINE PROTECTION

A well trained operator, working under suitable conditions, utilizing a modern, properly-equipped machine provides a machine-operator team capable of giving maximum production. These factors, along with appropriate job site rules and communication procedures, are essential to coordinate people and machines working together.

Appropriately protected and maintained machines are less likely to suffer premature component failure or damage, and give operators the confidence and assurance they need to carry out their work. Furthermore, training is not complete until the operator reads, understands and agrees to follow the instructions provided in the Operation and Maintenance Manual included with every Cat machine.

Employers have a duty to provide a safe work place for their employees. The purchaser of a Cat machine has a duty to review his/her particular application and job site for the machine to identify potential hazards inherent to that application or job site. Based on the results of this hazard analysis, the appropriate operator and machine protection configuration can be determined.

Caterpillar designs, builds, and tests its products to ensure the safety of operators, maintenance persons, service persons, and bystanders. That means people in, on and around Cat products. Caterpillar provides as standard equipment the appropriate operator and machine protection for most applications. However, particular applications, including the use of some Work Tools, may require additional operator and/or machine protection. Caterpillar offers related options for most such applications. However, there may be very special applications where the Cat dealer or the Purchaser may want to fabricate, or request Caterpillar to provide, custom or special guarding. Your Cat dealer can help you with this hazard analysis and guarding configuration process.

I. Operator Training and Protection Practices

Remember that any kind of machine or mechanical device can be hazardous if not kept in good condition, or if operated by careless or improperly trained operators, or if operated in an irresponsible manner.

Listed below are some recommended basic steps that can be broadly applied to most work environments:

- Train operators for the job they are assigned to do. The length and type of training must comply with governmental and local regulations wherever they apply. As an example, machine operators in mining activities must be trained in accordance with Mine Safety and Health Administration (MSHA) regulations. Where specific regulations do not apply, no operator should be assigned to a job until he or she meets the following minimum requirements:
 - Completes proper training to operate the assigned machine and understands that seat belts must be worn whenever seated in operator's compartment. **SEAT BELTS SAVE LIVES!**
 - Reads and understands the Operation & Maintenance manual for that machine, and knows that a copy of that manual is stored in the operator's compartment.
 - Reads and understands the AEM (Association of Equipment Manufacturers) Safety Manual, or any other furnished manual related to rules for safe machine operation and identification of hazards. For example, that includes the Work Tool Operation and Maintenance Manual if a Cat Work Tool is involved in the given application.
 - Has appropriate personal protective equipment and knows how to use it. This includes such things as hard hat, gloves, safety glasses, hearing protection, high-visibility vest, and safety shoes.
 - Knows what the job requirements are, what other machines are working in the area, and is aware of any hazardous conditions that may arise.

- Be sure operators are alert and in proper physical and mental condition to perform their work assignments safely. No machine should be operated by a person who is drowsy, under the affect of medicines or drugs, suffers blackouts, or is suffering from any physical or mental distraction that could contribute to unsafe operation.
- Maintain proper job conditions and working procedures. Check the job for possible hazards, both above and below ground level. Look for all possible sources of danger to the operator and others in the area. When operating in hazardous conditions the door and windows must always be closed. Pay particular attention to conditions which may be hazardous or near the operating limits of the machine: e.g., side slopes, steep grades, potential overloads, etc. Examine the work site for restricted traffic patterns, obstructed views, congestion, underground power or gas lines, etc. If the machine is equipped with a Quick Coupler, always make sure the Work Tool is properly attached by conducting an attachment test as directed in the Quick Coupler or Machine Operation and Maintenance Manual. Hazardous work conditions should be corrected wherever possible and adequate warnings should be posted when applicable.
- Provide the correct machine to handle the job and equip it properly for the job to provide the necessary operator protection. Check for compliance with all applicable governmental and local regulations. It is the legal responsibility of the machine owner or employer to see that his equipment complies with, and is operated in accordance with, all such requirements.
- Make sure the machine is properly maintained. The operator at the beginning of each shift should perform a walk-around inspection before the machine is placed in operation. This process is described in the machine and Work Tool Operation and Maintenance Manual. If this inspection reveals any problems that could affect safety, the machine or Work Tool must not be operated until these problems are corrected. Some examples include:
 - Loose, bent or missing grab irons, railings or steps;
 - Worn, cut or missing seat belts (any seat belt over three (3) years old must be replaced regardless of condition);
 - Damaged windows in the operator's compartment;
 - Worn, rubbing or abraded electrical insulation and hydraulic hoses;
 - Material or unwanted debris accumulation;
 - Incompatibility of the component attachments (Quick Couplers);
 - Hydraulic leaks that could impair the lock/secure feature of a Quick Coupler or other securing devices;
 - Any fluid leaks; and
 - Missing or damaged guards.
- Know the limits of your machine and equipment. With certain Work Tool combinations, including Quick Couplers, the Work Tool can hit the cab or the machine. Always check for interference limits when first operating.
- It is the machine owner's or employer's responsibility to ensure the machine is properly maintained. Your Cat dealer will be glad to assist you in selecting and equipping the machine best suited for your job and in providing maintenance for your machines.

II. Machine Modifications

Modifications must not be made to the machine that:

- Interfere with operator visibility;
- Interfere with ingress or egress from the machine;
- Exceed the rated payload or gross combination weight of the machine resulting in overloading the braking and/or steering system or the roll-over protective structure (ROPS) capacity rating (shown on a plate affixed to the ROPS); or
- Place objects in the cab that intrude into the operator's space or that are not firmly fixed into place.
- Are not authorized by Caterpillar.

III. Operator-related Equipment Options

Each job presents unique conditions that must be taken into account. Consider direct dangers to the operator as well as all possible sources of distraction that could reduce operator efficiency and increase the chances of costly and dangerous mistakes. Climate-controlled, sound-suppressed cabs, and special exterior lighting are options available from Caterpillar that can address requirements of special working environments.

“Flexible” machines include hydraulic excavators (track-type, wheel-type, and compact), skid-steer loaders, backhoe loaders and integrated tool-carriers can utilize interchangeable “Work Tools” to accomplish specific tasks. Work Tools or any tool used in hazardous applications like demolition, quarry, logging, stump grinding, scrap handling, milling, and scaling, can create a need for special operator guarding. When flying debris from impact, cutting, shearing or sweeping attachments is present, additional protective devices such as a front screen, Falling Object Guarding System (FOGS, includes top & front guarding), thick polycarbonate windshields or a combination of these is recommended by Caterpillar. The failure to provide proper operator/machine guarding in some of these applications can lead to machine damage, personal injury or death. Contact your Cat dealer for operator guarding options on your machine.

IV. Machine Protection

Check the job for unusually demanding conditions that could cause premature failure or excessive wear of machine components. Additional protective devices such as heavy-duty radiator guards, crankcase guards, engine enclosures, track roller guards and/or brake shields may be needed. Also, consider the use of anti-vandalism devices, such as cap locks and instrument panel guards. The failure to provide proper guarding in some of these applications may lead to machine damage, personal injury or death. Contact your Cat dealer for machine-protection and vandalism-prevention options for your machine.

V. Fire Prevention

Remember that most fluids on your machine are flammable!

To minimize the risk of fire, Caterpillar recommends following these basic steps:

- Always perform the Walk-Around Inspection described in Part I. It can identify many of the fire hazards described below.
- Remove trash (leaves, twigs, papers, etc.) that may accumulate in the engine compartment or around other hot parts on the product.
- Do not operate a machine if leakage of flammable fluids is noticed. Repair leaks before resuming machine operation. Most fluids used in Cat machines should be considered flammable.
- Keep access doors to major machine compartments in working order to permit the use of fire fighting equipment, should a fire occur.
- Avoid attaching electrical wiring to hoses and tubes that contain flammable or combustible fluids. Hydraulic hoses can move during machine operation and abrade wires and other hoses if improperly secured.
- Replace any rubbing, damaged, frayed, kinked or leaking hydraulic hoses or fittings. Use genuine Cat parts or their equivalent, including both pressure and temperature limit capabilities.
- Follow safe fueling practices as described in Cat Operation and Maintenance Manuals, AEM Safety Manuals, and local regulations. Never store flammable fluids in the machine operator's compartment, nor smoke while fueling the machine.
- As an additional safety measure, keep a fire extinguisher on the machine in a location as specified in the Operation and Maintenance Manual.
- Consider installation of an after-market fire-suppression system (FSS) on the equipment if the application and working conditions warrant it.

VI. Safety Regulations

Regulations vary from country to country and often within country. Your Cat dealer can assist you in properly equipping your machine to meet applicable requirements. **Note: The general summaries given below are not substitutes for Owners or Employers reading and being familiar with the appropriate local laws.**

(a) United States (US)

With a few exceptions, all machine operations in the United States are covered by federal and/or state regulations. If the machine is used in mining activities, the regulations are administered by the Mine Safety and Health Administration (MSHA). Other activities, including construction, are under regulations administered by the Occupational Safety and Health Administration (OSHA). These agencies require employers to provide a safe working environment for employees. Caterpillar has the same objective.

OSHA and MSHA have adopted criteria for ROPS, Falling Object Protective Structures (FOPS), seat belts, warning horns, back-up alarms, operator sound levels, steering systems, and braking systems. Additional operator's compartment protection may be required for machines engaged in logging, demolition and other special applications.

(b) European Union (EU)

The EU Machinery Safety Directive applies to Cat machines and most work tools. It requires that the "CE mark" be applied to the product and that a manufacturer's declaration be provided. The "CE mark" indicates that safety issues have been addressed by applying the appropriate safety standards in the design and manufacture of the machine. The objective of the Safety Directive is to protect operators, spectators and maintenance personnel. Caterpillar fully supports this objective.

VII. Sound Suppression

Different marketing areas have different noise emission requirements. Noise regulations usually specify limits for operators and spectators.

(a) United States

OSHA and MSHA noise-control regulations set permissible noise-exposure limits for machine operators and employees. Operator protection from machine noise can be achieved by use of factory-built cabs as offered in the Caterpillar Price List. These cabs, when properly maintained and operated with the doors and windows closed, reduce the operator sound level for an eight-hour operating period to meet the OSHA and MSHA noise-exposure limits in effect at the date of manufacture. Variables that may be encountered on the job site, such as other nearby noise sources or noise-reflecting surfaces, may reduce the allowable work hours. If this occurs, hearing protection may be required. This is especially true if a machine is not equipped with a closed cab. For example if the machine has no cab, or is being operated with the doors or windows opened.

(b) European Union

Operator sound-exposure requirements for machines in Europe are very similar to the OSHA and MSHA regulations mentioned above. In addition to operator sound-exposure requirements, most types of Cat machines are subject to European Commission regulations for exterior sound levels. Caterpillar ensures its products sold in the EU comply with the applicable noise regulations.

VIII. Replacement Parts for your Cat Machine

WARNING

When replacement parts are required for this product, Caterpillar recommends using Cat replacement parts or parts with equivalent specifications including, but not limited to, physical dimensions, type, strength and material. Failure to heed this warning can lead to premature failures, product damage, personal injury or death of persons on, or around, the product.

Nomenclature

THE CAT PRODUCT LINE

ARTICULATED TRUCKS

Capacity 23.6 to 39.5 metric tons (26 to 43.5 U.S. tons)

*OEM Solutions Group non-dumper/bare chassis for specialty applications available

725C*
730C*

730C EJ
735C*

740C EJ
745C*

BACKHOE LOADERS

Digging depth 4348 to 6501 mm (14'3" to 21'4")

415F2
416F2
420F2/420F2 IT
422F2

427F2
428F2
430F2/430F2 IT
432F2

434F2
444F2
450F

DRILLS

Rotary Drills

MD6240
MD6290
MD6420

MD6420B
MD6540

MD6640

Track Drills

MD5050
MD5050T

MD5075
MD5090

MD5150C

FOREST PRODUCTS

Track Harvesters

501HD 541 Series 2
521B 552 Series 2
522B

Track Feller Bunchers

521B 541 Series 2
522B 552 Series 2

Wheel Feller Bunchers

553C
563C
573C

Felling Heads

HF201B SH-56B
HF221 SS-56
SC-57

SATCO Directional Felling Heads

SAT420 SAT630

Harvester Heads

HH44 DE

SATCO Processor Heads

SAT214 SAT322T SAT323
SAT318 SAT322T SC SAT323T
SAT318T SAT422 DB SAT323T SC
SAT318T SC SAT223 SAT325
SAT322 SAT223T SAT325T

Wheel Skidders

525C
535C
545C

Track Skidders

527 Cable
527 Grapple

Forwarders

564
574
584/584HD

Forest Machines

320D FM 325D FM
324D FM 568 FM

Knuckleboom Loaders

529 519 SM
559C 519 SM/EHC
579C 569 SM
569 SM/EHC

Wheel Loaders

924K	950H	966H	986H
926M	950K	966K	988K
930K	950M	966M	990K
930M	962H	980H	
938K	962K	980K	
938M	962M	980M	

Site Prep

586C

Work Tools

Grapples
Logging Forks
Couplers
Buckets and Thumbs
Woodchip Dozers and Scoops
Rakes

HIGHWALL MINING SYSTEM

HW300

HYDRAULIC EXCAVATORS

Front Shovels

Operating Weight 90 080 to 91 700 kg (198,592 to 202,164 lb)

385C FS

Hydraulic Excavators

Operating Weight 1650 to 90 390 kg (3640 to 199,220 lb)

Track Models

MINI EXCAVATORS

300.9D
301.4C
301.7D
301.7D CR
302.2D
302.4D
302.7D CR
303E CR
303.5E CR
303.5E2 CR
304E2 CR
305E2 CR
305.5E2 CR
307E2
308E2 CR SB

SMALL EXCAVATORS

311F L
312D2 L
312E
312E L
312F GC
313D2
313D2 GC
313D2 L
313D2 LGP
313F L
313F L GC
314E
314E L
316E L
316F L
318D2 L
318E L
318F L

MEDIUM EXCAVATORS

320D2 325F L
320D2 GC 326D2 L
320D2 L 326F
320E 326F L
320E L 326F LN
320E LRR 330D2 L
320E RR 329E
320F L 329E L
323D2 L 329E LN
323E L 330F
323E LN 330F L
323E SA 330F LN
323F L 335F L
324E
324E L
324E LN

LARGE EXCAVATORS

336D2 349D2 – FIX
336D2 GC 349D2 L – FIX
336D2 L 349E L – FIX
336E 349E L – VG
336E L 349F L – FIX
336E H 349F L XE – FIX
336E L H 352F – VG
336F 352F XE – VG
336F L 374D L
336F LN 374F L
336F XE 390D
336F L XE 390D L
336F LN XE 390F L
340D2 L
340F L
340F LN

Wheel Models

M313D M315D M315D2 M316D M317D2 M318D M320D2 M322D M322D2
M314F M316F M318F M320F M322F

HYDROMECHANICAL ATTACHMENTS

Hydraulic Hammers

H25D H110E s
H35E/E s H115E s
H45E/E s H120E s
H55E/E s H130E s
H65E/E s H140E s
H75E s H160E s
H95E s H180E s

Mobile Scrap and Demolition Shears

S305 S340B
S320B S365C
S325B S385C

Multi-Processors

MP15 MP318
MP20 MP324
MP30
MP40

Contractor's Grapples

G107B G130B
G112B G145B
G115B G165B
G120B G185B
G125B

Demolition and Sorting Grapples

G305 G315B
G330 G320B
G310B G325B

Orange Peel Grapples

GSH15B
GSH20B
GSH22B

MATERIAL HANDLERS

Wheel Material Handlers

M322D2 MH M325D MH MH3022 MH3037 MH3059
M324D2 MH M325D LMH MH3024 MH3049

Track Material Handlers

385C MH

MINING & OFF-HIGHWAY TRUCKS

Payload capacity 36 to 363 metric tonnes (40 to 400 tons)

*OEM Solutions Group non-dumper for special applications available

770G* 773G* 777G* 789D 793F 795F AC
772G* 775G* 785C 793D XLWS MT5300D AC 797F
773E 777D 785D*

MOTOR GRADERS

Flywheel power 93 to 397 kW (125 to 533 hp)

*All Wheel Drive.

120K	12M2	140M2	160M2
120K2	12M2 with AWD* option	140M2 with AWD* option	160M2 with AWD* option
120M	12M3	140M3	160M3
120M with AWD* option	12M3 with AWD* option	140M3 with AWD* option	160M3 with AWD* option
120M2	140K	160K	14M Global
120M2 with AWD* option	140K2	160M	16M3 Global
12K	140M	160M with AWD* option	18M3 Global
12M	140M with AWD* option		24M Global

ON-HIGHWAY TRUCKS

Model	Front Axle	Chassis	BBC	BA
CT660S	SBA	6x4	116"	54"
CT660S	SBA	8x6	116"	54"
CT660L	SBA	6x4	122"	54"
CT660L	SBA	4x4	122"	54"
CT660L	SBA	6x6	122"	54"
CT660L	SBA	8x6	122"	54"
CT680	SFA	6x4	124"	30"
CT680	SFA	8x6	124"	30"
CT681	SFA	6x4	114"	28"

SBA = Set Back Axle
SFA = Set Forward Axle
BBC = Bumper to Back of Cab (inches)
BA = Bumper to Front Axle
L = Long Hood
S = Short Hood

Chassis A x B

A = Total Wheel Ends
B = Powered Wheel Ends

PAVING PRODUCTS

Cold Planers

PM102 PM200 — 2.0 m PM200 — 2.2 m

Reclaimer/Soil Stabilizers

Cutting width 2438 mm (8'0")

RM300 RM500B

Asphalt Pavers

AP300D AP600F AP255E AP655F
AP500E AP1000F AP555E AP1055F

Pneumatic Tire Asphalt Compactors

PS150C CW14 CW34

Vibratory Compactors

Single Drum Smooth

Drum width 1270 to 2130 mm
(4'2" to 7'0")

Single Drum, Padded

Drum width 1270 to 2130 mm
(4'2" to 7'0")

Double Drum and Combi

Drum width 1000 to 2130 mm
(3'3.4" to 7'0")

CS34	CS54B	CS74B	CP34	CP54B	CB14B	CB34B	CB54 XW
CS423E	CS56B	CS76B	CP44	CP56B	CB14B XW	CB34B XW	CB64
CS44	CS64B	CS78B	CP44B	CP68B	CB22B	CC34B	CB64B
CS44B	CS66B	CS79B	CP533E	CP74B	CB24B	CB44B	CB66B
CS533E	CS68B				CB24B XT	CD44B	CB68B
					CC24B	CB54B	
					CB32B	CD54B	

PIPELAYERS

Lifting capacity 18 145 to 91 625 kg (40,000 to 202,000 lb)

PL61

572R2

PL83

PL87

SKID STEER LOADERS/MULTI TERRAIN LOADERS/COMPACT TRACK LOADERS

Operating Weight 2581 to 5265 kg (5690 to 11,608 lb)

Skid Steer Loaders

216B3 242D
226B3 246D
226D 262D
232D 272D2
236D 272D2 XHP

Multi Terrain Loaders

257D
277D
287D
297D2
297D2 XHP

Compact Track Loaders

239D
249D
259D
279D
289D
299D2
299D2 XHP

Work Tools

Augers

A7B
A14B
A19B
A26B

Backhoes

BH150
BH160

Brooms

BA18
BP15B
BP18B
BU115
BU118

Brushcutters

BR160
BR166
BR172
BR272
BR378

Cold Planers

PC104B
PC205B
PC305B
PC306B
PC408B
PC410B

Vibratory

Compactors
CV16B
CV18B

Mulchers

HM315B
HM415B

Landscape Rakes

LR15B
LR18B

Power Box Rakes

PR172
PR184
PR190

Wheel Saws

SW345B
SW360B
SW380B
SW460B
SW480B

Snow Blowers

SR117
SR118
SR121
SR318
SR321

Stump Grinder

SG16B
SG18B

Landscape Tillers

LT13B
LT18B

Trenchers

T6B
T9B
T15B

SURFACE MINING EXTRACTION

Draglines

8000
8200
8750 — 22.9 m (75'0") Base
8750 — 25.6 m (84'0") Base

Electric Rope Shovels

7295 7495 HydraCrowd™
7395 7495 HF Rope Crowd
7495 HD 7495 HF HydraCrowd
7495 Rope Crowd

Hydraulic Mining Shovels

Operating Weight 105 200 to 980 000 kg (231,920 to 2,610,510 lb)

Backhoe Configurations

6015 Standard Attachment
6015 Mass Excavation Attachment
6018
6020B
6030
6040
6050
6060

Backhoe Configuration with Electric Drive

6018 AC
6030 AC
6040 AC
6050 AC
6060 AC

Front Shovel Configurations

6015 FS 6040 FS 6060 FS
6018 FS 6050 FS 6090 FS
6030 FS

Front Shovel Configuration with Electric Drive

6018 AC FS 6040 AC FS 6060 AC FS
6030 AC FS 6050 AC FS 6090 AC FS

TELESCOPIC HANDLERS

Non-U.S. Versions

TH255C	TH407C	TL642C
TH336C	TH414C	TL943C
TH337C	TH417C	TL1055C
TH406C	TH514C	TL1255C

U.S. Versions

TH255C	TL642C
TH406C	TL943C
TH407C	TL1055C
TH514C	TL1255C

TRACK LOADERS

Bucket Capacity (Heaped)* 1.15 to 3.2 m³ (1.5 to 4.2 yd³)

953D†

963D†

973D†

*General Purpose Bucket.

†Waste handling arrangement available.

TRACK-TYPE TRACTORS

Flywheel power 55 to 634 kW (74 to 850 hp)

D3K XL (LRC)	D5K XL (LRC)	D6K2 XL
D3K LGP (LRC)	D5K LGP (LRC)	D6K2 LGP
D3K2 XL	D5K2 XL	D6N XL*
D3K2 LGP	D5K2 LGP	D6N LGP*
D4K XL (LRC)	D5R2 XL*	D6R2
D4K LGP (LRC)	D5R2 LGP*	D6R2 XL*
D4K2 XL	D5T XL*	D6R2 LGP*
D4K2 LGP	D5T LGP*	

*Waste Handling Arrangements (WHA)

D6T*	D7R* (LRC)	D9R (LRC)
D6T XL*	D7R XR* (LRC)	D9T*
D6T XW*	D7R LGP* (LRC)	D10T2
D6T LGP*	D8R* (LRC)	D11T
D7E*	D8R LGP* (LRC)	D11T CD
D7E LGP*	D8T*	
	D8T LGP*	

UNDERGROUND MINING EQUIPMENT

Hard Rock

Load-Haul-Dump

Bucket sizes 2.4-11.6 m³ (3.1-15.2 yd³)

R1300G	R2900G
R1600H	R3000H
R1700G	

Articulated Trucks

30-60 t (33-66T) capacity

AD30	AD55 Flat Haul
AD45B	AD60

Hard Rock Cutting/ Conveying

Rock Flow System

Longwall

Roof Supports

AFC Systems

AFC Line Pans

PF3	PF6
PF4	PF7
PF5	

Beam Stage Loaders

BSL Line Pans

PF4	PF6
PF5	

BSL Crushers

SK0909	SK1218
SK1111	SK1422
SK1118	

BSL Drive Frames

SPR3	SPR5
------	------

BSL Gearboxes

K10	KP-25/30
-----	----------

Boot End

SMB	CMB
-----	-----

CST Drive Systems

CST30	CST45 M
CST45	CST65
CST45 V	CST115

Automated Plow Systems

RHH800
GH800
GH800B
GH1600

Shearers

EL2000	EL4000
EL3000	

Programmable

Mining Controls

PMC-R	PMC-D
PMC-V	MCU2

Variable Frequency Drives

VFD-A800/W800
VFD-A1200/W1200

Roof Support Carriers

SH640
SH640B
SH660
SH660B
SH620
SH630
SH650
SH680

Shield Trailer

SH150

Room & Pillar

Continuous Miners

CM210	CM340
CM220	CM345N
CM230	CM445
CM240	

Scoops

SU488L
SU488
SU488 D (non XP)

Load Haul Dumps

CL210
CL210B
CL215

Face Haulage

FH120

Continuous Haulage

FH330

Roof Bolter

RB220

Feeder Breaker

FB110

WHEEL DOZERS

Flywheel power 173 to 597 kW (232 to 801 hp)

814F2 824K 834K 844K 854K

LANDFILL COMPACTORS

Flywheel power 173 to 349 kW (232 to 468 hp)

816F2 826K 836K

SOIL COMPACTORS

Flywheel power 173 to 264 kW (232 to 354 hp)

815F2 825K

WHEEL LOADERS & INTEGRATED TOOLCARRIERS

Bucket Capacity (Heaped) 0.6 to 30 m³ (0.78 to 40 yd³)

* High lift arrangement available.

† Waste handling arrangement available.

901C	924K	950 GC	966M XE	986H
902C	926M*†	950H*†	972H*†	988K*
903C	930K*	950K*†	972K*†	990K*
906K	930M*†	950M*†	972M*†	992K*
906M	938K*	962H*†	972M XE	993K*
907K	938M*†	IT62H†	980H*†	994K*
907M		962K*†	980K*†	
908K		962M*†	980M*†	
908M		966H*†	982M	
910K*		966K*†		
914K*		966M*†		

WHEEL TRACTOR-SCRAPERS

Standard Models

Heaped capacity 18 to 26 m³ (24 to 34 yd³)

621K 631K

Tandem Powered Scrapers

Heaped capacity 18 to 33.6 m³ (24 to 44 yd³)

627K 637K 657G

Elevating Scrapers

Heaped capacity 17.6 m³ (23 yd³)

623K

Coal Bowl Scrapers

Heaped capacity 38 to 56 m³ (50 to 73 yd³)

637K 657G

Push-Pull Scrapers

Heaped capacity 18 to 33.6 m³ (24 to 44 yd³)

627K 637K 657G

ARTICULATED TRUCKS

CONTENTS

Features	1-1
Specifications	1-2
Ground Pressure	1-6
Curves:	
725C Rimpull-Speed-Gradeability, Brake/Retarder Performance Curve	1-9
730C Rimpull-Speed-Gradeability, Brake/Retarder Performance Curve	1-13
730C EJ Rimpull-Speed-Gradeability, Brake/Retarder Performance Curve	1-17
735C Series Rimpull-Speed-Gradeability, Brake/Retarder Performance Curve	1-21
740C EJ Series Rimpull-Speed-Gradeability, Brake/Retarder Performance Curve	1-25
745C Series Rimpull-Speed-Gradeability, Brake/Retarder Performance Curve	1-29

Features:

- **Cat® engines with ACERT™ Technology** meet U.S. EPA Tier 4 Final/EU Stage IV/Japan 2014 (Tier 4 Final), or Tier 2/Stage II/Japan 2001 (Tier 2) equivalent emission standards. The four core elements of meeting these standards are:
 - I) Common Rail;
 - II) Electronics, ADEM™ A4;
 - III) Fuel delivery, Mechanical-activated Electronic Unit Injection (MEUI™ A-C);
 - IV) Air Management, Wastegate Turbocharging, Air to Air Aftercooling (ATAAC) with the proven technology of a crossflow cylinder head.
- **Cat electronically controlled transmissions** ... Transmissions purpose built and designed for articulated trucks and their applications. Advanced Productivity Electronic Control Strategy (APECS) delivering smooth shifting transmissions with improved acceleration and high productivity. Providing complete integration with the engines for efficient power delivery as well as offering advanced diagnostic and troubleshooting capabilities.

- **Articulating and fully oscillating hitch** ... Links front and rear frames for exceptional maneuverability and traction on uneven terrain while eliminating damaging twisting of the frames. Bolted hitch design allows optimum material choices for the cast hitch head and the hard-wearing tube. Bolted design allows easier rebuild and repair.
- **Three-point front suspension** ... Three-point front suspension with long-stroke, low-pressure suspension cylinders provide unparalleled ride quality for operator comfort and higher average haul speeds. Front and rear suspension together with the hitch provide for excellent traction in all conditions.
- **Wide, long and low dump body design** ... For excellent loadability and high fill factors, excellent machine stability and load retention as well as a good match for other Cat loading systems. Diverging flow design also gives excellent material ejection.
- **Standard ROPS/FOPS, low sound level cab** ... Two man cab common across the range. Large cab with excellent all around visibility, ergonomic control layout and plentiful storage.
- **High capacity low pressure tires in single formation** ... For superior traction and flotation in poor underfoot conditions.
- **Bare Chassis offerings** ... For certain applications the Caterpillar OEM Solutions Group offers non-dumper/Bare Chassis arrangements.

Bare Chassis arrangements applications could include: water, service (fuel and lube), high capacity body (waste, coal, etc.), open body (log, pipe, etc.), container carrier, hook lift, tow, cable reel, etc. Please refer to specific OEM for additional information.

MODEL	725C		730C		730C EJ	
Gross Power — SAE J1995	239 kW	320 hp	280 kW	375 hp	280 kW	375 hp
Net Power — SAE J1349	234 kW	314 hp	274 kW	367 hp	274 kW	367 hp
Net Power — ISO 14396	236 kW	316 hp	276 kW	370 hp	276 kW	370 hp
Net Power — EEC 80/1269	236 kW	316 hp	276 kW	370 hp	276 kW	370 hp
Operating Weight (Empty)*	23 220 kg	51,191 lb	24 100 kg	53,131 lb	26 800 kg	59,084 lb
Top Speed (Loaded)	56 km/h	35 mph	55 km/h	34 mph	55 km/h	34 mph
GMW — Gross Machine Weight	46 820 kg	103,220 lb	52 100 kg	114,860 lb	54 920 kg	121,078 lb
Distribution Empty:						
Front		62.1%		62.3%		59%
Center		19.6%		19.5%		21%
Rear		18.3%		18.2%		20%
Distribution Loaded:						
Front		36.1%		35.1%		30%
Center		32.3%		32.8%		35.3%
Rear		31.6%		32.1%		34.7%
Max. Capacity**	23.6 t	26T	28 t	31T	28 t	31T
Struck (SAE)	11 m ³	14.4 yd³	13.3 m ³	17.4 yd³	13.5 m ³	17.7 yd³
Heaped (2:1) (SAE)	15 m ³	19.6 yd³	17.5 m ³	23 yd³	16.9 m ³	22.1 yd³
Tailgate Heaped SAE 2:1	15.6 m ³	20.4 yd³	18.8 m ³	24.6 yd³	—	—
Tailgate Struck	11.1 m ³	14.5 yd³	13.9 m ³	18.2 yd³	—	—
Engine Model	C9.3 ACERT		C13 ACERT		C13 ACERT	
No. Cylinders	6		6		6	
Bore	115 mm	4.53"	130 mm	5.1"	130 mm	5.1"
Stroke	149 mm	5.87"	157 mm	6.18"	157 mm	6.18"
Displacement	9.3 L	567 in³	12.5 L	763 in³	12.5 L	763 in³
Tires, Front, Center, Rear	23.5R25 Radials		23.5R25 Radials		750/65 Radials	
Circular Clearance Diameter	16.2 m	53'0"	16.2 m	53'0"	15.2 m	49'9"
Fuel Tank Refill Capacity	410 L	108.3 U.S. gal	410 L	108.3 U.S. gal	410 L	108.3 U.S. gal
DEF Tank Capacity	20 L	5.3 U.S. gal	20 L	5.3 U.S. gal	20 L	5.3 U.S. gal
General Dimensions (Empty):						
Height to Cab Top	3.47 m	11'4"	3.48 m	11'4"	3.45 m	11'3"
Wheel Base (Front-Center of Bogie)	4.83 m	15'8"	4.83 m	15'8"	4.83 m	15'8"
Overall Length	10.45 m	34'3"	10.45 m	34'3"	10.38 m	34'0"
Loading Height (Empty)	2.73 m	8'9"	2.91 m	9'6"	3.03 m	9'9"
Height at Full Dump	6.31 m	20'7"	6.46 m	21'2"	—	—
Body Length	5.69 m	18'7"	5.78 m	19'0"	5.35 m	17'6"
Width (Operating — Over Mirrors)	3.70 m	12'2"	3.70 m	12'2"	3.70 m	12'2"
Front Tire Tread	2.28 m	7'5"	2.28 m	7'5"	2.28 m	7'5"

*Includes coolant, lubricant and full fuel tank.

**Rating dependent on optional equipment. Maximum gross weight (empty weight plus payload) should not be exceeded.

MODEL	725C		730C		730C EJ	
Gross Power — SAE J1995	239 kW	320 hp	280 kW	375 hp	280 kW	375 hp
Net Power — SAE J1349	234 kW	314 hp	274 kW	367 hp	274 kW	367 hp
Net Power — ISO 14396	236 kW	316 hp	276 kW	370 hp	276 kW	370 hp
Net Power — EEC 80/1269	236 kW	316 hp	276 kW	370 hp	276 kW	370 hp
Operating Weight (Empty)*	22 950 kg	50,596 lb	23 700 kg	52,250 lb	26 400 kg	58,202 lb
Top Speed (Loaded)	56 km/h	35 mph	55 km/h	34 mph	55 km/h	34 mph
GMW — Gross Machine Weight	46 550 kg	102,625 lb	51 700 kg	113,979 lb	54 520 kg	120,196 lb
Distribution Empty:						
Front		61.2%		61%		57.8%
Center		20.1%		20.2%		21.7%
Rear		18.7%		18.8%		20.5%
Distribution Loaded:						
Front		35.5%		34.2%		29.2%
Center		32.6%		33.2%		35.7%
Rear		31.9%		32.6%		35.1%
Max. Capacity**	23.6 t	26T	28 t	31T	28 t	31T
Struck (SAE)	11 m ³	14.4 yd³	13.3 m ³	17.4 yd³	13.5 m ³	17.7 yd³
Heaped (2:1) (SAE)	15 m ³	19.6 yd³	17.5 m ³	23 yd³	16.9 m ³	22.1 yd³
Tailgate Heaped SAE 2:1	15.6 m ³	20.4 yd³	18.8 m ³	24.6 yd³	—	—
Tailgate Struck	11.1 m ³	14.5 yd³	13.9 m ³	18.2 yd³	—	—
Engine Model	C9.3 ACERT		C13 ACERT		C13 ACERT	
No. Cylinders	6		6		6	
Bore	115 mm	4.53"	130 mm	5.1"	130 mm	5.1"
Stroke	149 mm	5.87"	157 mm	6.18"	157 mm	6.18"
Displacement	9.3 L	567 in³	12.5 L	763 in³	12.5 L	763 in³
Tires, Front, Center, Rear	23.5R25 Radials		23.5R25 Radials		750/65 Radials	
Circular Clearance Diameter	16.2 m	53'0"	16.2 m	53'0"	15.2 m	49'9"
Fuel Tank Refill Capacity	410 L	108.3 U.S. gal	410 L	108.3 U.S. gal	410 L	108.3 U.S. gal
General Dimensions (Empty):						
Height to Cab Top	3.47 m	11'4"	3.48 m	11'4"	3.45 m	11'3"
Wheel Base (Front-Center of Bogie)	4.83 m	15'8"	4.83 m	15'8"	4.83 m	15'8"
Overall Length	10.45 m	34'3"	10.45 m	34'3"	10.38 m	34'0"
Loading Height (Empty)	2.73 m	8'9"	2.91 m	9'6"	3.03 m	9'9"
Height at Full Dump	6.31 m	20'7"	6.46 m	21'2"	—	—
Body Length	5.69 m	18'7"	5.78 m	19'0"	5.35 m	17'6"
Width (Operating — Over Mirrors)	3.70 m	12'2"	3.70 m	12'2"	3.70 m	12'2"
Front Tire Tread	2.28 m	7'5"	2.28 m	7'5"	2.28 m	7'5"

*Includes coolant, lubricant and full fuel tank.

**Rating dependent on optional equipment. Maximum gross weight (empty weight plus payload) should not be exceeded.

MODEL	735C Series		740C EJ Series		745C Series	
Gross Power — SAE J1995	337 kW	452 hp	381 kW	511 hp	381 kW	511 hp
Net Power — SAE J1349	329 kW	441 hp	370 kW	496 hp	370 kW	496 hp
Net Power — ISO 14396	333 kW	447 hp	376 kW	504 hp	376 kW	504 hp
Operating Weight (Empty)*	31 500 kg	69,446 lb	36 000 kg	79,366 lb	33 400 kg	73,634 lb
Top Speed (Loaded)	53.9 km/h	33.5 mph	54.8 km/h	34 mph	54.8 km/h	34 mph
GMW — Gross Machine Weight	64 200 kg	141,537 lb	74 000 kg	163,142 lb	74 400 kg	164,024 lb
Distribution Empty:						
Front		60%		57%		59%
Center		19%		22%		21%
Rear		21%		21%		20%
Distribution Loaded:						
Front		34%		30%		35%
Center		33%		35%		33%
Rear		33%		35%		32%
Max. Capacity**	32.7 t	36T	38 t	42T	41 t	45.2T
Struck (SAE)	15 m ³	19.6 yd³	18 m ³	23.5 yd³	18.5 m ³	24.2 yd³
Heaped (2:1) (SAE)	20.5 m ³	26.8 yd³	23 m ³	30.1 yd³	25 m ³	32.7 yd³
Tailgate Heaped SAE 2:1	22 m ³	28.7 yd³	—	—	26.5 m ³	34.7 yd³
Tailgate Struck	15.5 m ³	20.3 yd³	—	—	19.5 m ³	25.5 yd³
Engine Model	C15 ACERT		C18 ACERT		C18 ACERT	
No. Cylinders	6		6		6	
Bore	137 mm	5.4"	145 mm	5.7"	145 mm	5.7"
Stroke	171.5 mm	6.75"	183 mm	7.2"	183 mm	7.2"
Displacement	15.2 L	926 in³	18.1 L	1106 in³	18.1 L	1106 in³
Tires, Front, Center, Rear	26.5R25 Radials		29.5R25 Radials		29.5R25 Radials	
Circular Clearance Diameter	16 840 mm	663.0"	18 069 mm	711.4"	18 069 mm	711.4"
Fuel Tank Refill Capacity	480 L	126.8 U.S. gal	550 L	145.3 U.S. gal	550 L	145.3 U.S. gal
DEF Tank Capacity	23 L	6.1 U.S. gal	23 L	6.1 U.S. gal	23 L	6.1 U.S. gal
General Dimensions (Empty):						
Height to Cab Top	3684 mm	145.0"	3725 mm	146.7"	3725 mm	146.7"
Wheel Base (Front-Center of Bogie)	5109 mm	201.1"	5573 mm	219.4"	5573 mm	219.4"
Overall Length	11 061 mm	435.5"	11 776 mm	463.6"	11 429 mm	450.0"
Loading Height (Empty)	2932 mm	115.4"	2987 mm	117.6"	3101 mm	122.1"
Height at Full Dump	6550 mm	257.9"	—	—	7239 mm	285.0"
Body Length	5912 mm	232.8"	6761 mm	266.2"	6447 mm	253.8"
Width (Operating — Over Mirrors)	4166 mm	164.0"	4166 mm	164.0"	4166 mm	164.0"
Front Tire Tread	2687 mm	105.8"	2687 mm	105.8"	2687 mm	105.8"

*Includes coolant, lubricant and full fuel tank.

**Rating dependent on optional equipment. Maximum gross weight (empty weight plus payload) should not be exceeded.

MODEL	735C Series		740C EJ Series		745C Series	
Gross Power — SAE J1995	336 kW	450 hp	381 kW	511 hp	381 kW	511 hp
Net Power — SAE J1349	329 kW	450 hp	370 kW	496 hp	370 kW	496 hp
Net Power — ISO 14396	333 kW	447 hp	376 kW	484 hp	376 kW	484 hp
Operating Weight (Empty)*	31 200 kg	68,784 lb	35 600 kg	78,484 lb	33 000 kg	72,752 lb
Top Speed (Loaded)	53.9 km/h	33.5 mph	54.8 km/h	34 mph	54.8 km/h	34 mph
GMW — Gross Machine Weight	63 900 kg	140,875 lb	73 600 kg	162,260 lb	74 000 kg	163,142 lb
Distribution Empty:						
Front		60%		56%		58%
Center		19%		23%		21%
Rear		21%		21%		21%
Distribution Loaded:						
Front		33%		29%		34%
Center		33%		36%		33%
Rear		34%		35%		33%
Max. Capacity**	32.7 t	36T	38 t	42T	41 t	45.2T
Struck (SAE)	15 m ³	19.6 yd³	18 m ³	23.5 yd³	18.5 m ³	24.2 yd³
Heaped (2:1) (SAE)	20.5 m ³	26.8 yd³	23 m ³	30.1 yd³	25 m ³	32.7 yd³
Tailgate Heaped SAE 2:1	22 m ³	28.7 yd³	—	—	26.5 m ³	34.7 yd³
Tailgate Struck	15.5 m ³	20.3 yd³	—	—	19.5 m ³	25.5 yd³
Engine Model	C15 ACERT		C18 ACERT		C18 ACERT	
No. Cylinders	6		6		6	
Bore	137 mm	5.4"	145 mm	5.7"	145 mm	5.7"
Stroke	171.5 mm	6.75"	183 mm	7.2"	183 mm	7.2"
Displacement	15.2 L	926 in³	18.1 L	1106 in³	18.1 L	1106 in³
Tires, Front, Center, Rear	26.5R25 Radials		29.5R25 Radials		29.5R25 Radials	
Circular Clearance Diameter	16 840 mm	663.0	18 069 mm	711.4"	18 069 mm	711.4"
Fuel Tank Refill Capacity	550 L	145.3 U.S. gal	550 L	145.3 U.S. gal	550 L	145.3 U.S. gal
General Dimensions (Empty):						
Height to Cab Top	3684 mm	145.0"	3725 mm	146.7"	3725 mm	146.7"
Wheel Base (Front-Center of Bogie)	5109 mm	201.1"	5573 mm	219.4"	5573 mm	219.4"
Overall Length	11 061 mm	435.5"	11 776 mm	463.6"	11 429 mm	450.0"
Loading Height (Empty)	2932 mm	115.4"	2987 mm	117.6"	3101 mm	122.1"
Height at Full Dump	6550 mm	257.9"	—	—	7239 mm	285.0"
Body Length	5912 mm	232.8"	6761 mm	266.2"	6447 mm	253.8"
Width (Operating — Over Mirrors)	4166 mm	164.0"	4166 mm	164.0"	4166 mm	164.0"
Front Tire Tread	2687 mm	105.8"	2687 mm	105.8"	2687 mm	105.8"

*Includes coolant, lubricant and full fuel tank.

**Rating dependent on optional equipment. Maximum gross weight (empty weight plus payload) should not be exceeded.

Use of Ground Pressure Charts

Articulated trucks are normally equipped with wide base radial tires, for improved flotation in poor underfoot conditions. Ground pressure is a function of tire deflection and is also affected by tire penetration. The charts in this section provide a means to estimate ground pressure for 0 and 76 mm (3") tire penetration, when gross vehicle weight, axle load distribution and tire inflation pressure are known. The ground pressure charts on the following pages are based on Michelin XADN tire characteristics. Results may differ for other tread patterns.

Tire load can be calculated by the following formula:

$$\text{Tire Load} = \frac{\text{Heaviest Axle Load}}{2}$$

Example

Find the ground pressure generated by a 725C fully loaded with zero and 76 mm (3") tire penetration. The machine is equipped with standard Michelin 23.5R25 tires, inflated to the recommended pressure.

$$725\text{C Tire Load} = \frac{46\,820 \text{ kg} \times 0.34}{2} = 7959 \text{ kg}$$

$$725\text{C Tire Load} = \frac{103,220 \text{ lb} \times 0.34}{2} = 17,547 \text{ lb}$$

From the tire section in this book, inflation pressure for the 725C is 325 kPa = 3.25 bar (47 psi).

From the ground pressure chart for 23.5R25 tires, Ground pressure = 3.1 kg/cm² (44 psi) with zero tire penetration.

Ground pressure = 1.4 kg/cm² (21 psi) with 76 mm (3") tire penetration.

See the Wheel Tractor Scraper section for explanation on using:

- Rimpull-Speed-Gradeability Curves
- Retarder Curves

See Mining & Off-Highway Trucks section for Fixed Times for Hauling Units.

23.5R25 Tires*

30/65R25 Tires*

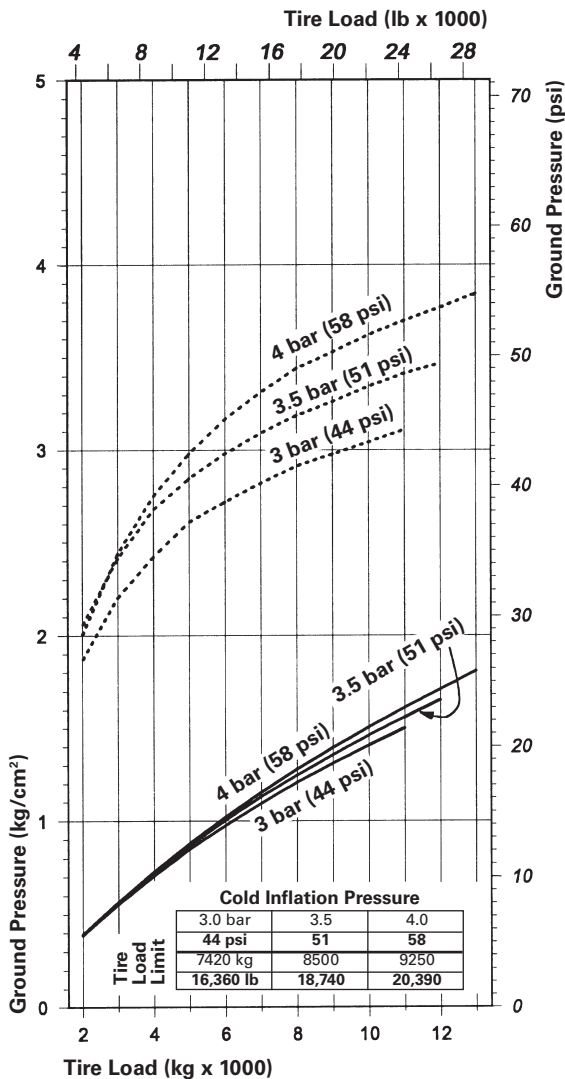
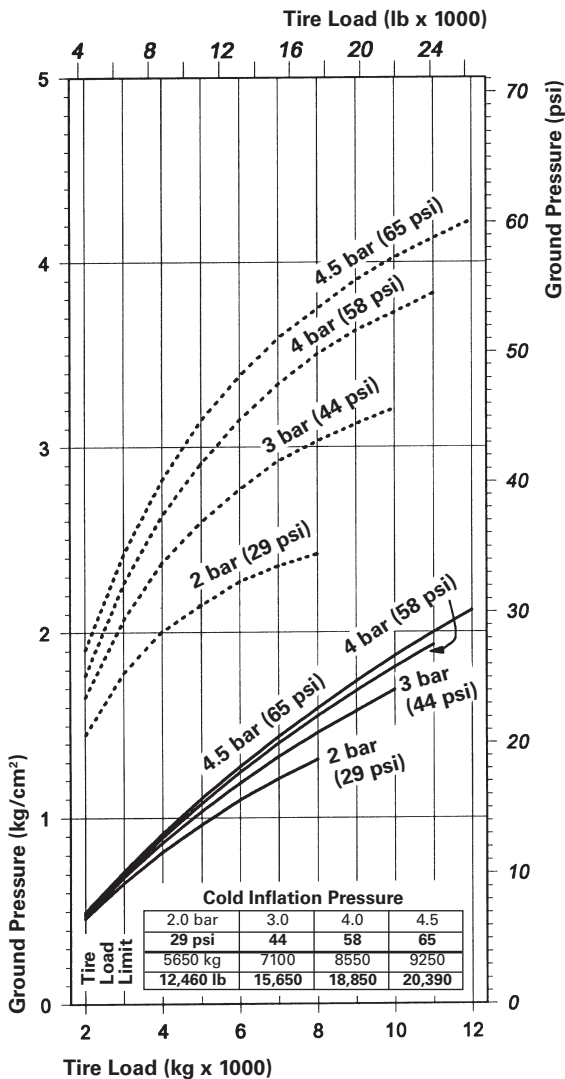

KEY

- Zero Penetration (Flat Plate)
- 76 mm (3") Penetration

*Charts based on Michelin XADN tire characteristics. Results may differ for other tread patterns and/or brands. Charts are to be used to calculate ground pressure. To determine the inflation as a function of load and conditions or when loads exceed tire load limit, contact your tire manufacturer representative.

26.5R25 Tires*

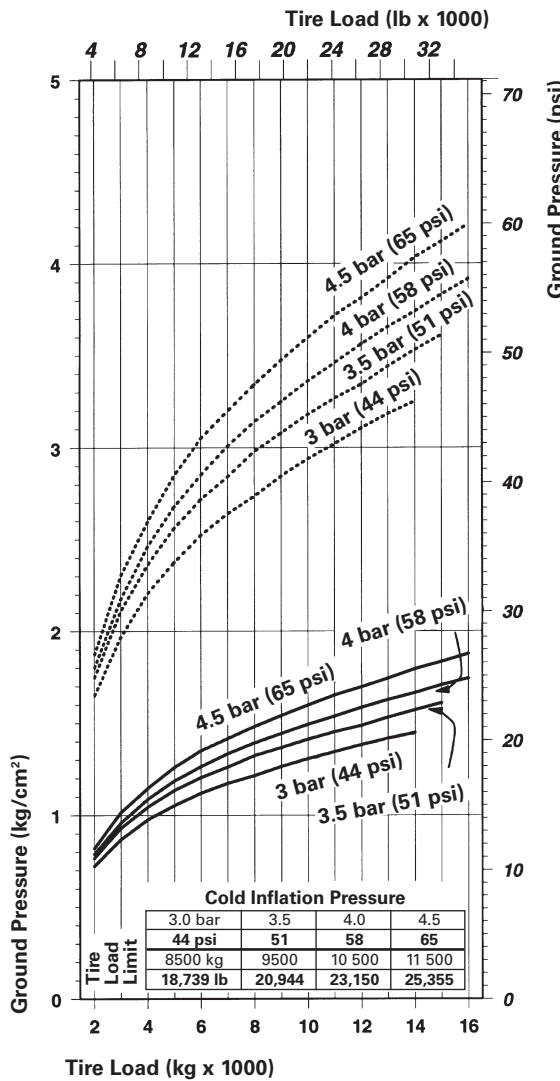

29.5R25 Tires*

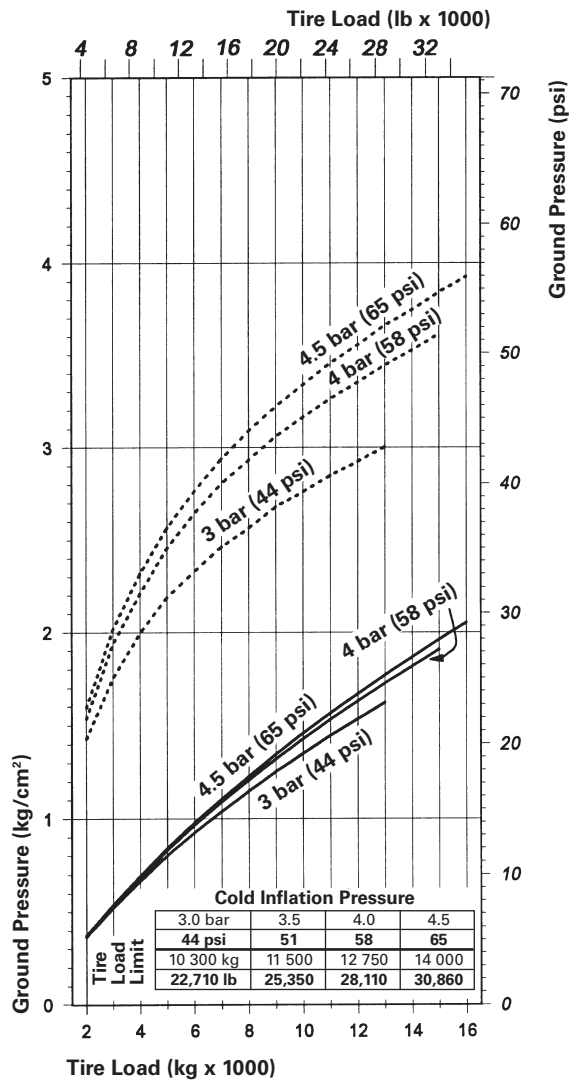

KEY

- Zero Penetration (Flat Plate)
- 76 mm (3") Penetration

*Charts based on Michelin XADN tire characteristics. Results may differ for other tread patterns and/or brands. Charts are to be used to calculate ground pressure. To determine the inflation as a function of load and conditions or when loads exceed tire load limit, contact your tire manufacturer representative.

- 23.5R25 Tires
- Tier 4 Final/Stage IV/Japan 2014 (Tier 4 Final)

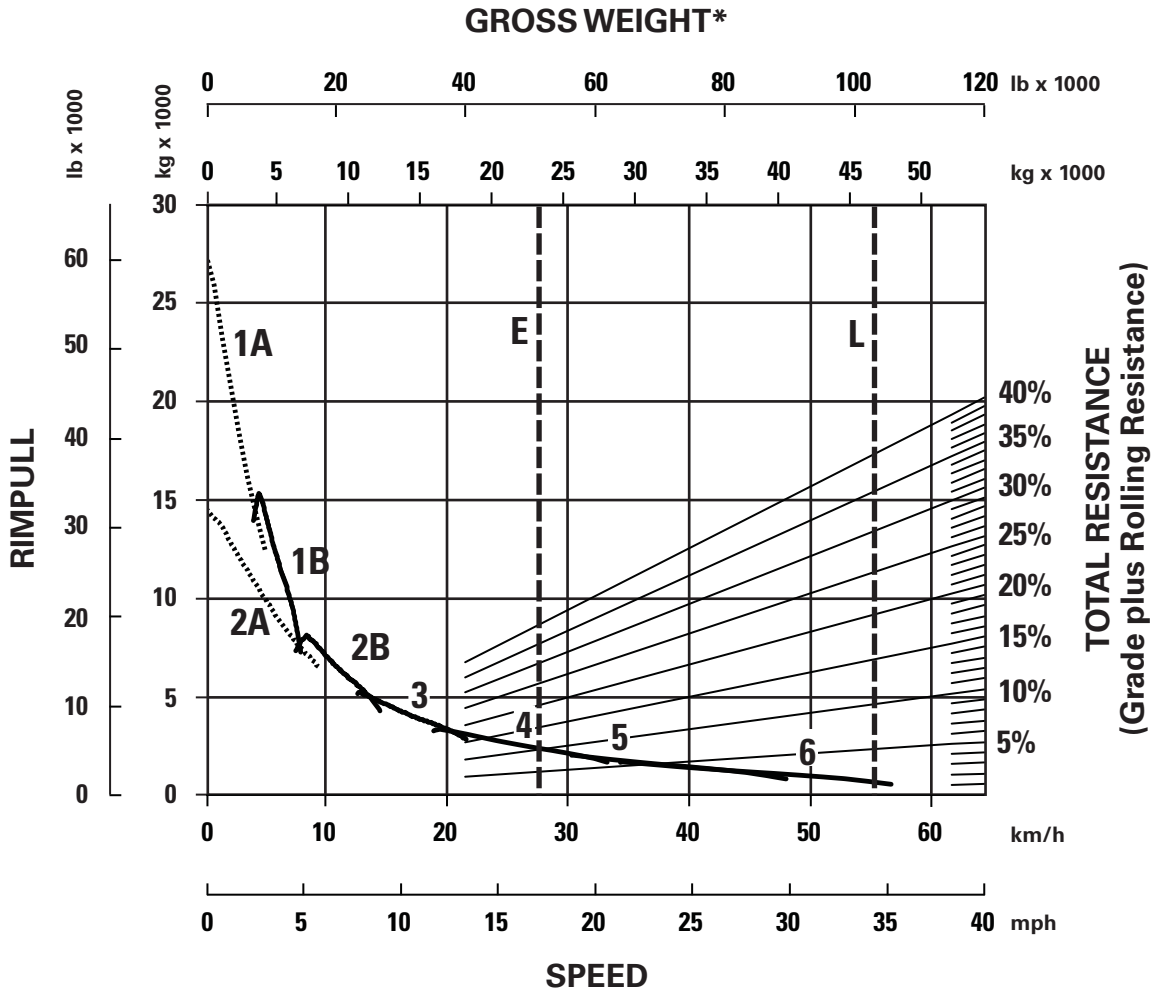

KEY

- 1A – 1st Gear (Converter Drive)
- 1B – 1st Gear (Direct Drive)
- 2A – 2nd Gear (Converter Drive)
- 2B – 2nd Gear (Direct Drive)
- 3 – 3rd Gear
- 4 – 4th Gear
- 5 – 5th Gear
- 6 – 6th Gear

KEY

- E – Empty 23 220 kg (51,191 lb)
- L – Loaded 46 820 kg (103,220 lb)

*At sea level.

Articulated Trucks

725C Brake/Retarder Performance Curve

- 23.5R25Tires
- Tier 4 Final/Stage IV/Japan 2014 (Tier 4 Final)

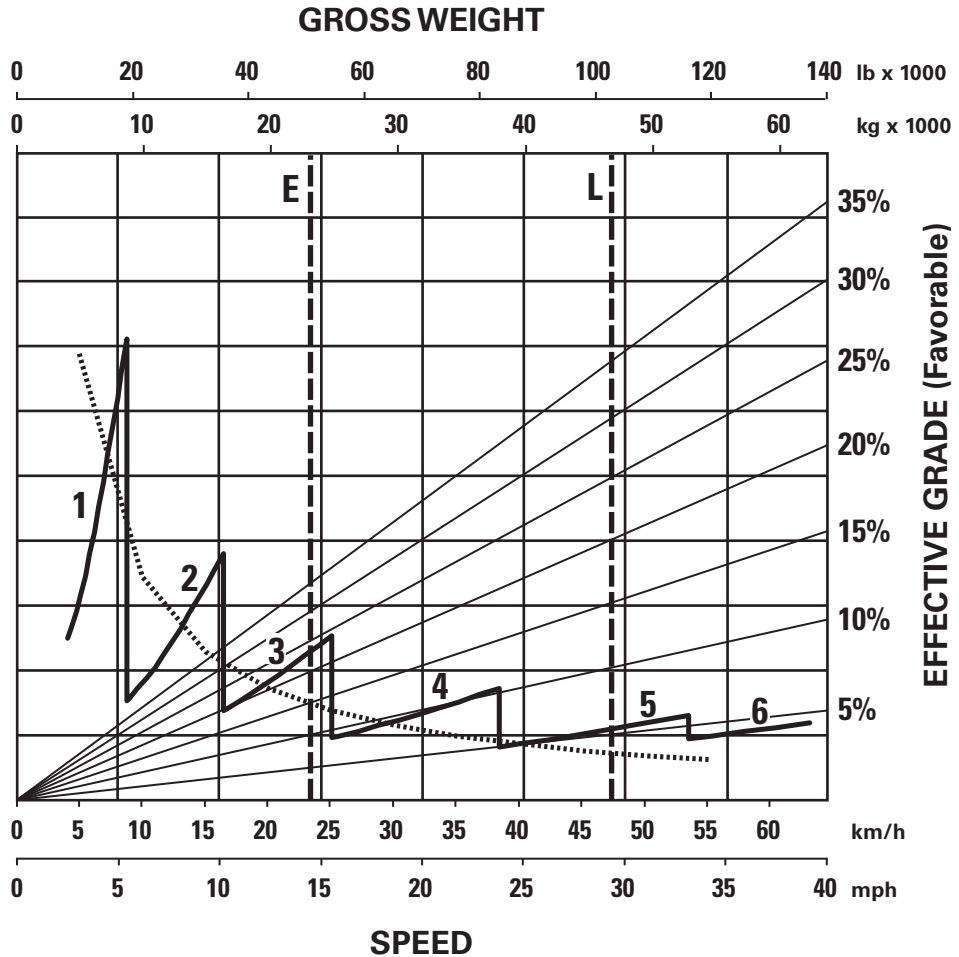

KEY

- 1 — 1st Gear
- 2 — 2nd Gear
- 3 — 3rd Gear
- 4 — 4th Gear
- 5 — 5th Gear
- 6 — 6th Gear

KEY

- E — Empty 23 220 kg (51,191 lb)
- L — Loaded 46 820 kg (103,220 lb)

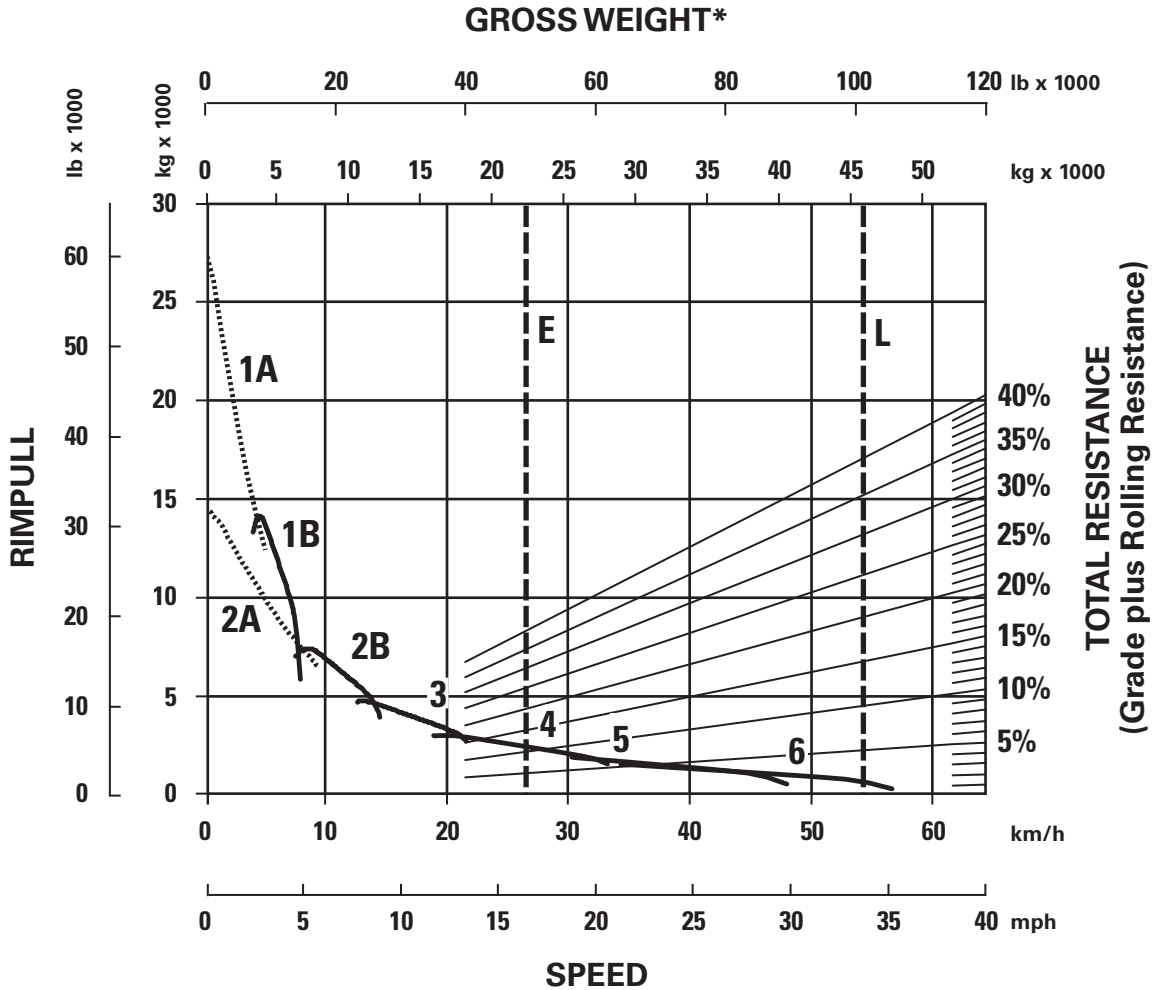

KEY

- 1A – 1st Gear (Converter Drive)
- 1B – 1st Gear (Direct Drive)
- 2A – 2nd Gear (Converter Drive)
- 2B – 2nd Gear (Direct Drive)
- 3 – 3rd Gear
- 4 – 4th Gear
- 5 – 5th Gear
- 6 – 6th Gear

KEY

- E – Empty 22 950 kg (50,596 lb)
- L – Loaded 46 550 kg (102,625 lb)

*At sea level.

Articulated Trucks

725C Brake/Retarder Performance Curve

- 23.5R25 Tires
- Tier 2/Stage II/Japan 2001 (Tier 2)

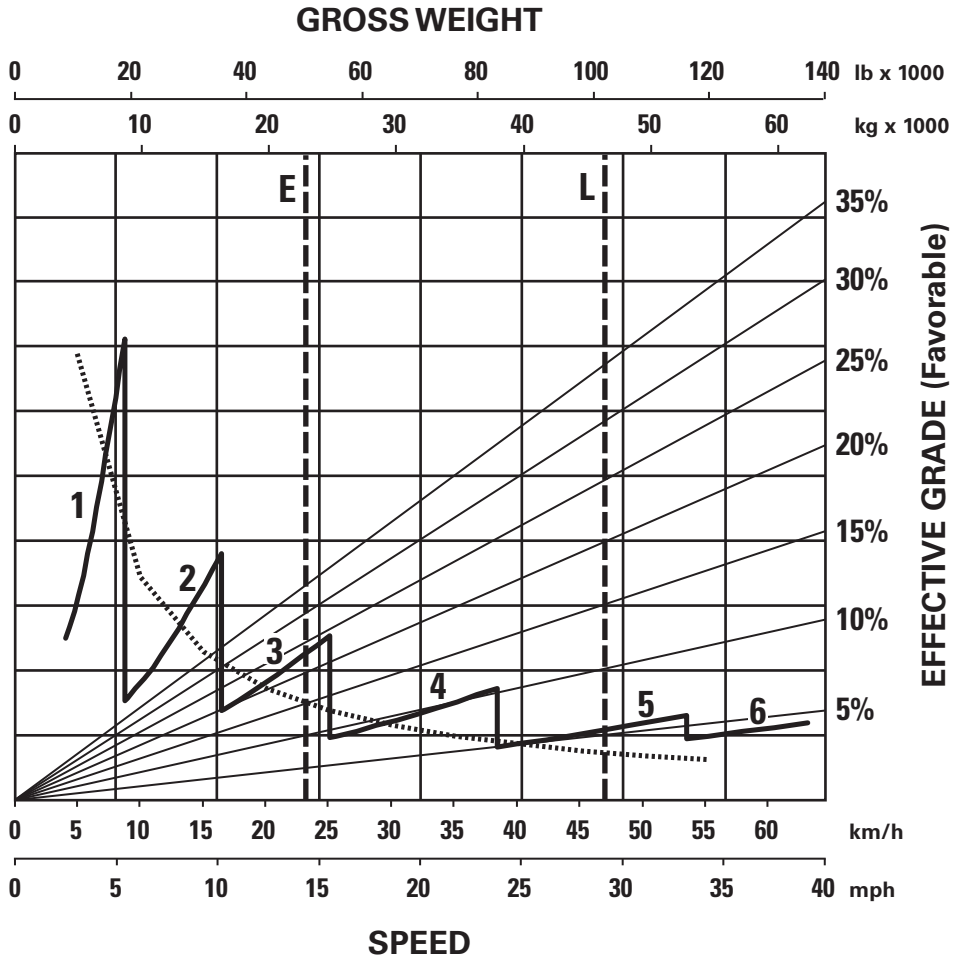

KEY

- 1 — 1st Gear
- 2 — 2nd Gear
- 3 — 3rd Gear
- 4 — 4th Gear
- 5 — 5th Gear
- 6 — 6th Gear

KEY

- E — Empty 22 950 kg (50,596 lb)
- L — Loaded 46 550 kg (102,625 lb)

730C Rimpull-Speed-Gradeability

Articulated Trucks

- 23.5R25 Tires
- Tier 4 Final/Stage IV/Japan 2014 (Tier 4 Final)

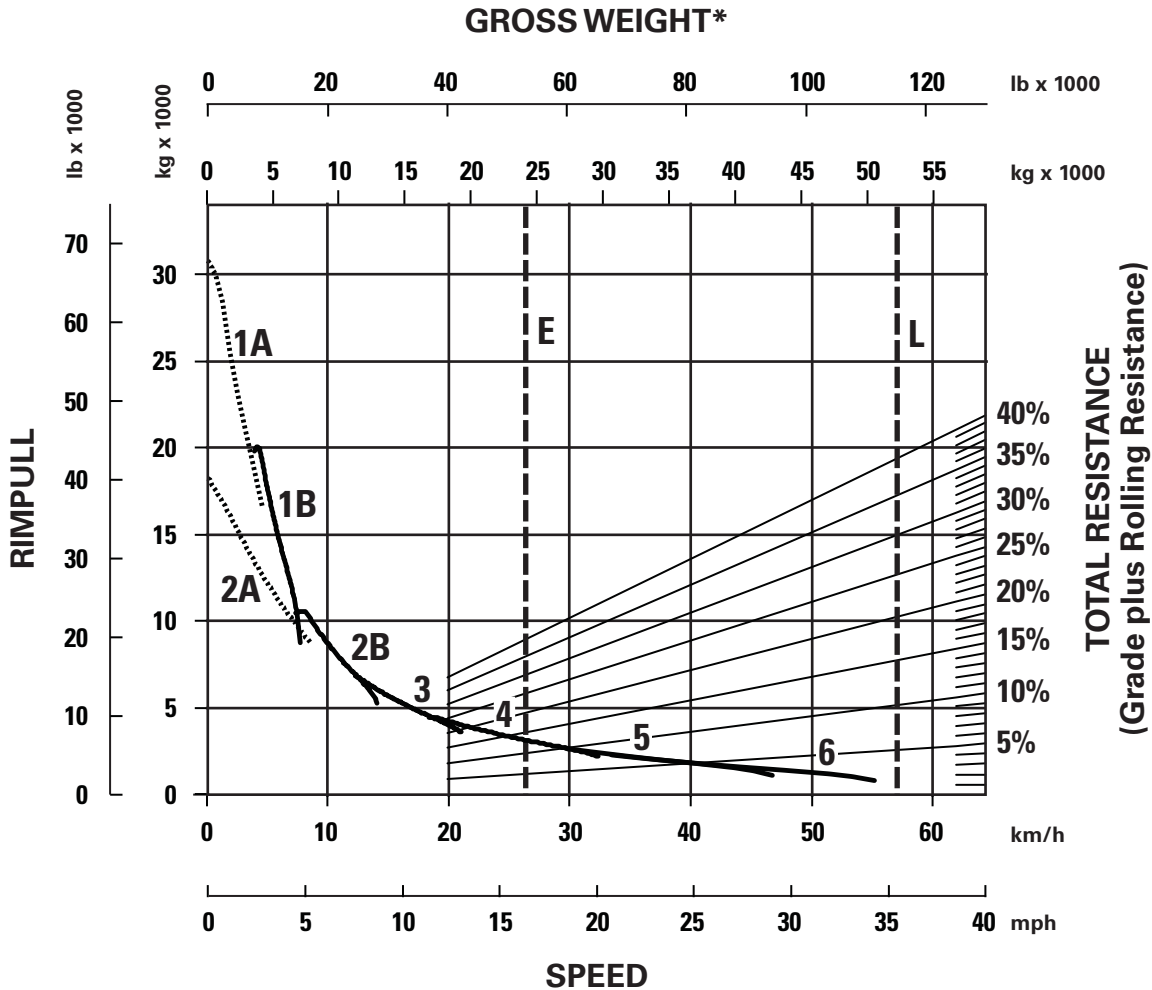

KEY

- 1A – 1st Gear (Converter Drive)
- 1B – 1st Gear (Direct Drive)
- 2A – 2nd Gear (Converter Drive)
- 2B – 2nd Gear (Direct Drive)
- 3 – 3rd Gear
- 4 – 4th Gear
- 5 – 5th Gear
- 6 – 6th Gear

KEY

- E – Empty 24 100 kg (53,131 lb)
- L – Loaded 52 100 kg (114,860 lb)

*At sea level.

Articulated Trucks

730C Brake/Retarder Performance Curve

- 23.5R25 Tires
- Tier 4 Final/Stage IV/Japan 2014 (Tier 4 Final)

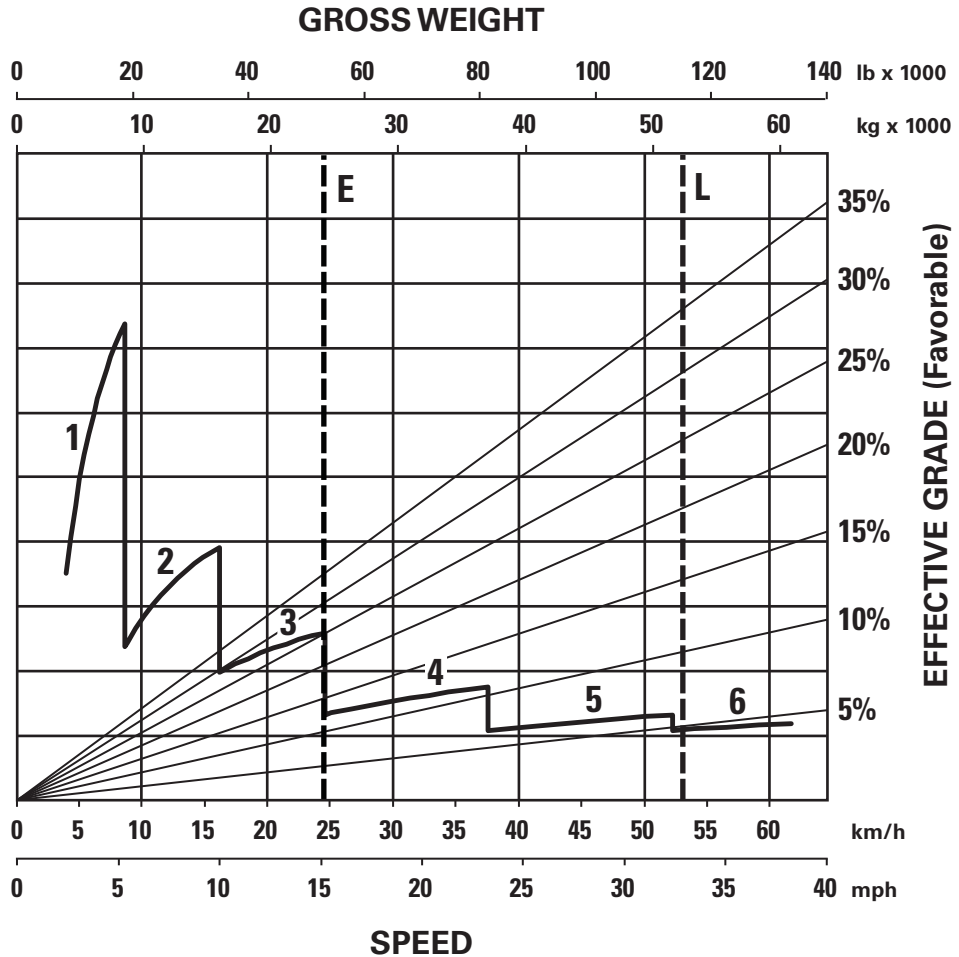

KEY

- 1 – 1st Gear
- 2 – 2nd Gear
- 3 – 3rd Gear
- 4 – 4th Gear
- 5 – 5th Gear
- 6 – 6th Gear

KEY

- E – Empty 24 100 kg (53,131 lb)
- L – Loaded 52 100 kg (114,860 lb)

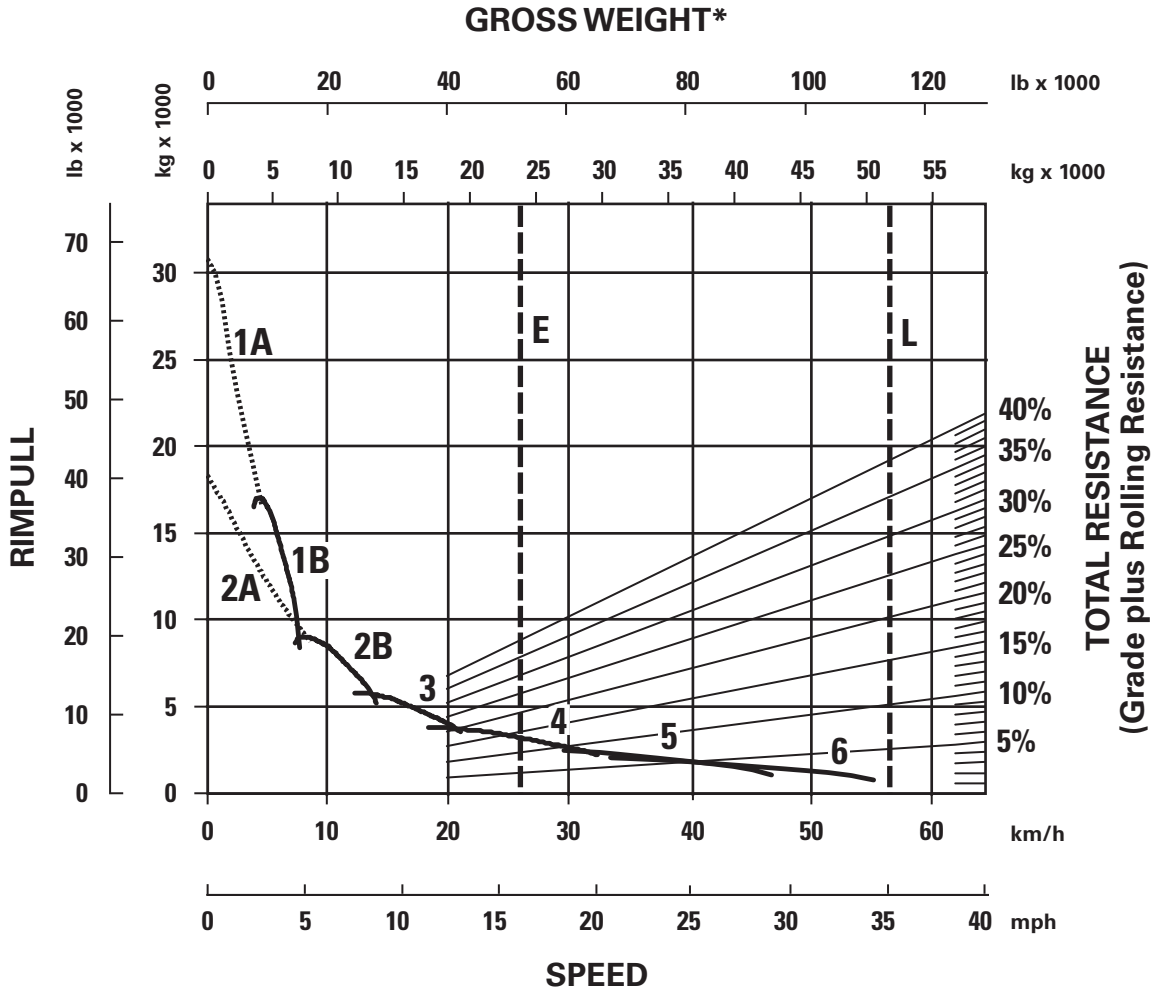

KEY

- 1A – 1st Gear (Converter Drive)
- 1B – 1st Gear (Direct Drive)
- 2A – 2nd Gear (Converter Drive)
- 2B – 2nd Gear (Direct Drive)
- 3 – 3rd Gear
- 4 – 4th Gear
- 5 – 5th Gear
- 6 – 6th Gear

KEY

- E – Empty 23 700 kg (52,250 lb)
- L – Loaded 51 700 kg (113,979 lb)

*At sea level.

Articulated Trucks

730C Brake/Retarder Performance Curve

- 23.5R25Tires
- Tier 2/Stage II/Japan 2001 (Tier 2)

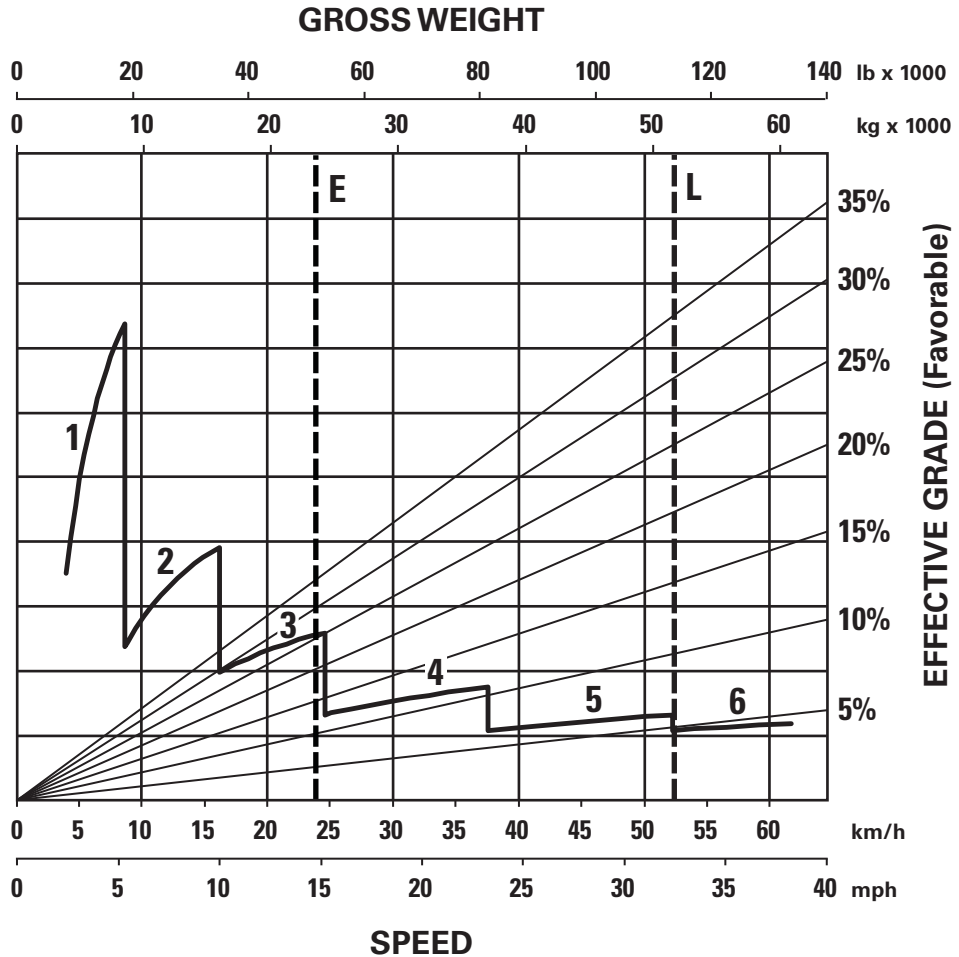

KEY

- 1 – 1st Gear
- 2 – 2nd Gear
- 3 – 3rd Gear
- 4 – 4th Gear
- 5 – 5th Gear
- 6 – 6th Gear

KEY

- E – Empty 23 700 kg (52,250 lb)
- L – Loaded 51 700 kg (113,979 lb)

● 750/65 Tires

● Tier 4 Final/Stage IV/Japan 2014 (Tier 4 Final)

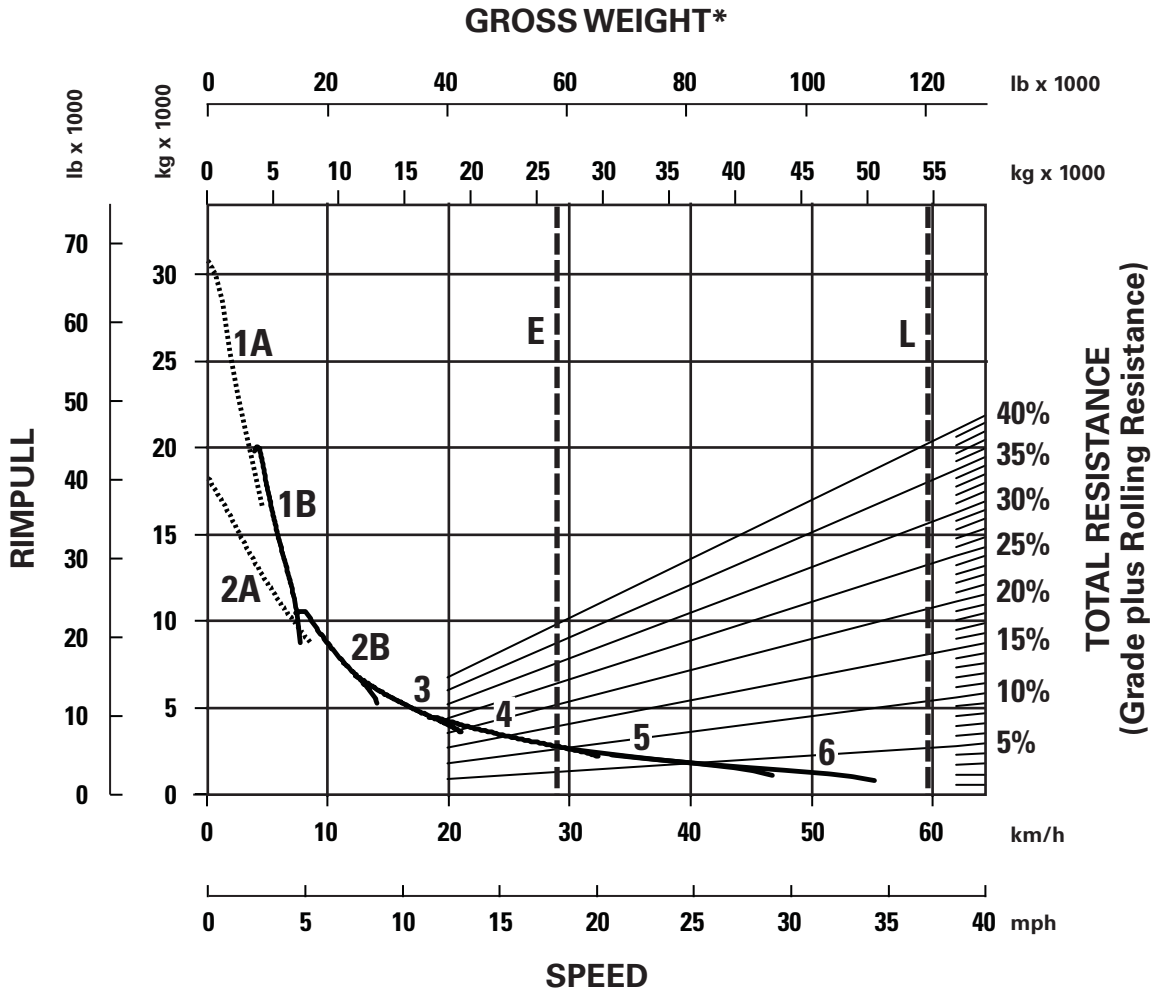

KEY

- 1A – 1st Gear (Converter Drive)
- 1B – 1st Gear (Direct Drive)
- 2A – 2nd Gear (Converter Drive)
- 2B – 2nd Gear (Direct Drive)
- 3 – 3rd Gear
- 4 – 4th Gear
- 5 – 5th Gear
- 6 – 6th Gear

KEY

- E – Empty 26 800 kg (59,084 lb)
- L – Loaded 54 920 kg (121,078 lb)

*At sea level.

Articulated Trucks

730C EJ Brake/Retarder Performance Curve

- 750/65 Tires
- Tier 4 Final/Stage IV/Japan 2014 (Tier 4 Final)

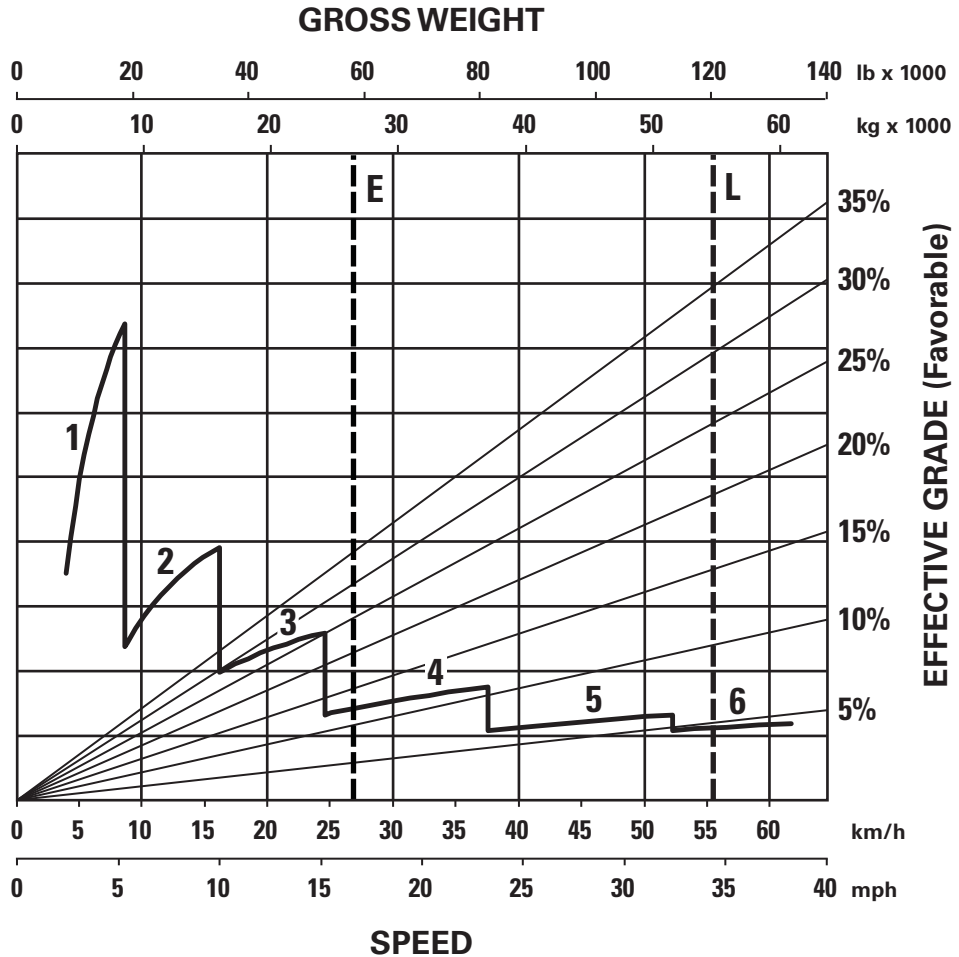

KEY

- 1 — 1st Gear
- 2 — 2nd Gear
- 3 — 3rd Gear
- 4 — 4th Gear
- 5 — 5th Gear
- 6 — 6th Gear

KEY

- E — Empty 26 800 kg (59,084 lb)
- L — Loaded 54 920 kg (121,078 lb)

● 750/65 Tires

● Tier 2/Stage II/Japan 2001 (Tier 2)

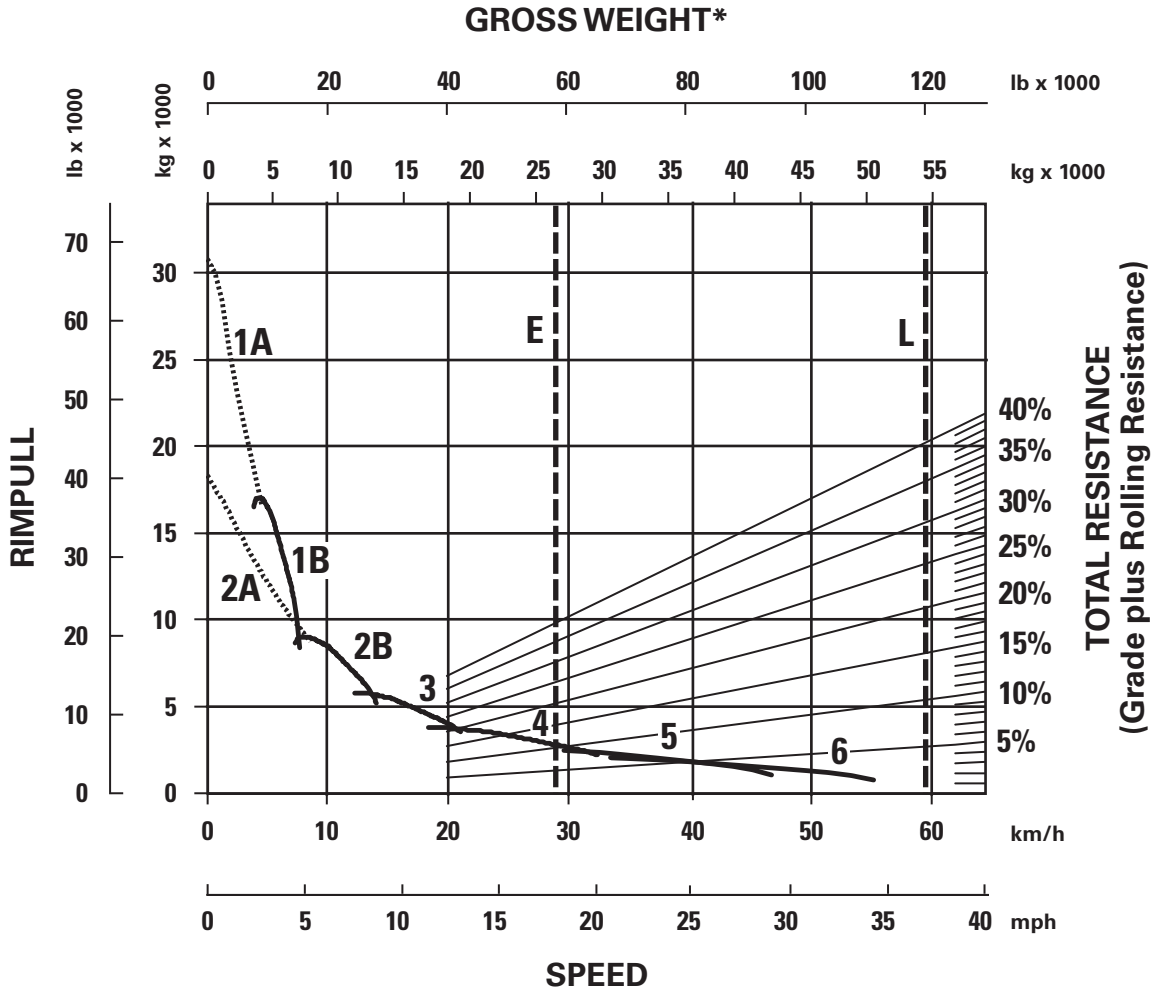

KEY

- 1A – 1st Gear (Converter Drive)
- 1B – 1st Gear (Direct Drive)
- 2A – 2nd Gear (Converter Drive)
- 2B – 2nd Gear (Direct Drive)
- 3 – 3rd Gear
- 4 – 4th Gear
- 5 – 5th Gear
- 6 – 6th Gear

KEY

- E – Empty 26 400 kg (58,202 lb)
- L – Loaded 54 520 kg (120,196 lb)

*At sea level.

Articulated Trucks

730C EJ Brake/Retarder Performance Curve

- 750/65 Tires
- Tier 2/Stage II/Japan 2001 (Tier 2)

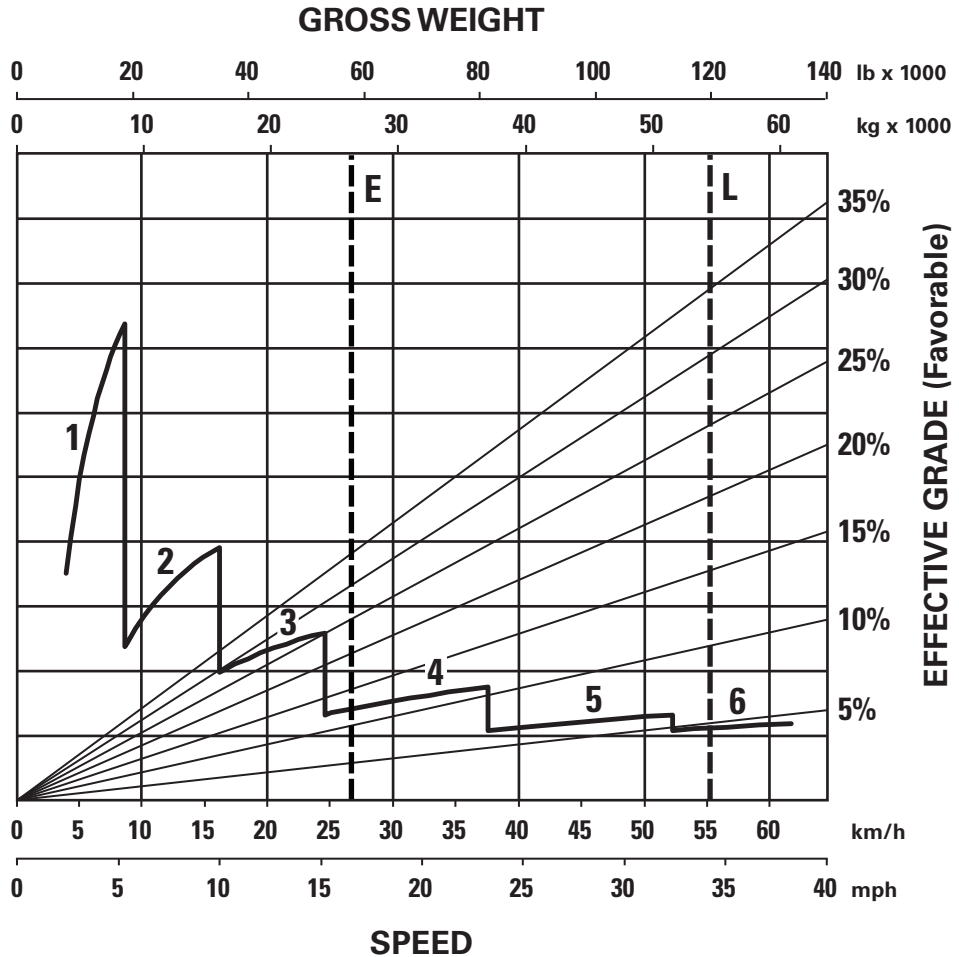

KEY

- 1 – 1st Gear
- 2 – 2nd Gear
- 3 – 3rd Gear
- 4 – 4th Gear
- 5 – 5th Gear
- 6 – 6th Gear

KEY

- E – Empty 26 400 kg (58,202 lb)
- L – Loaded 54 520 kg (120,196 lb)

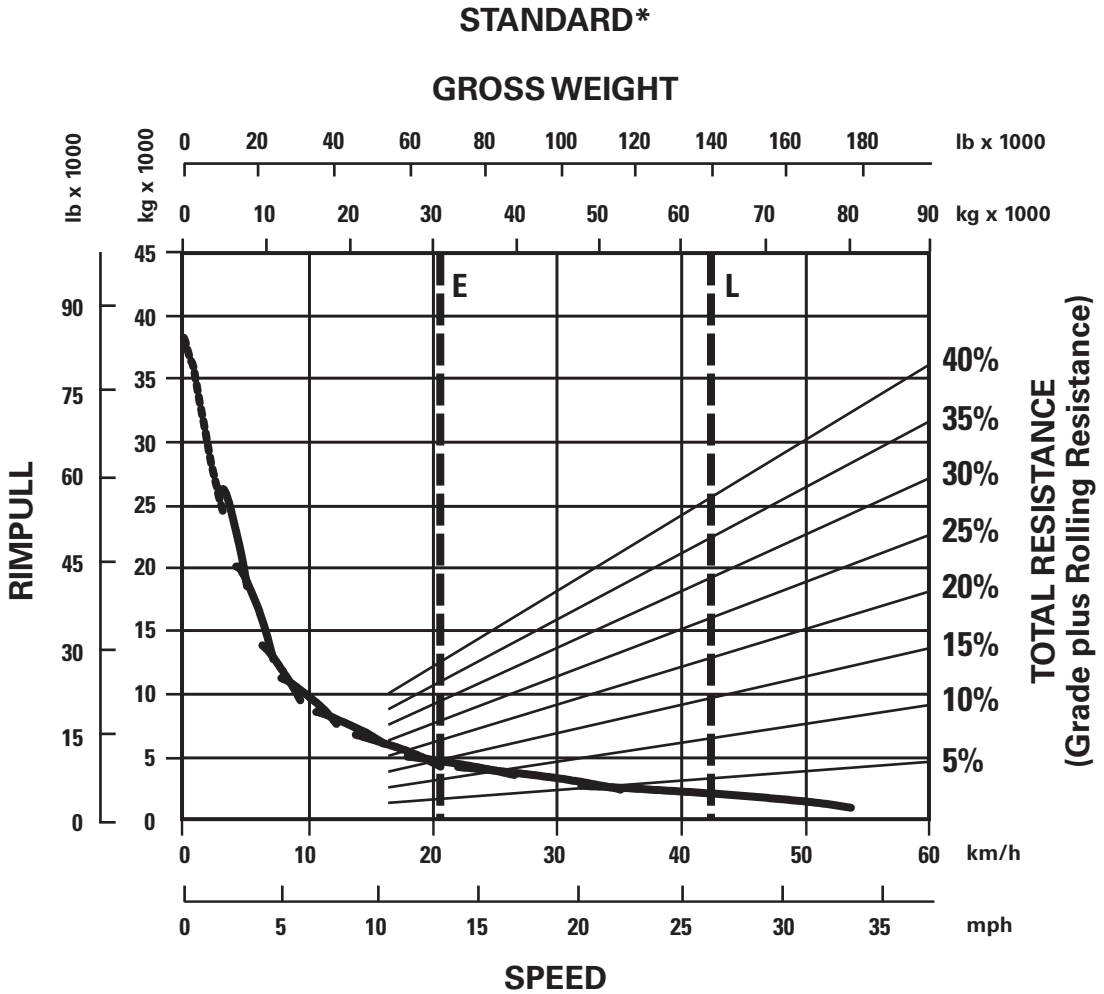

KEY

- E — Empty 31 220 kg (68,800 lb)
- L — Loaded 63 920 kg (140,900 lb)

*At sea level.

Articulated Trucks

735C Series Brake/Retarder Performance Curve

- 26.5R25Tires
- Tier 4 Final/Stage IV/Japan 2014 (Tier 4 Final)

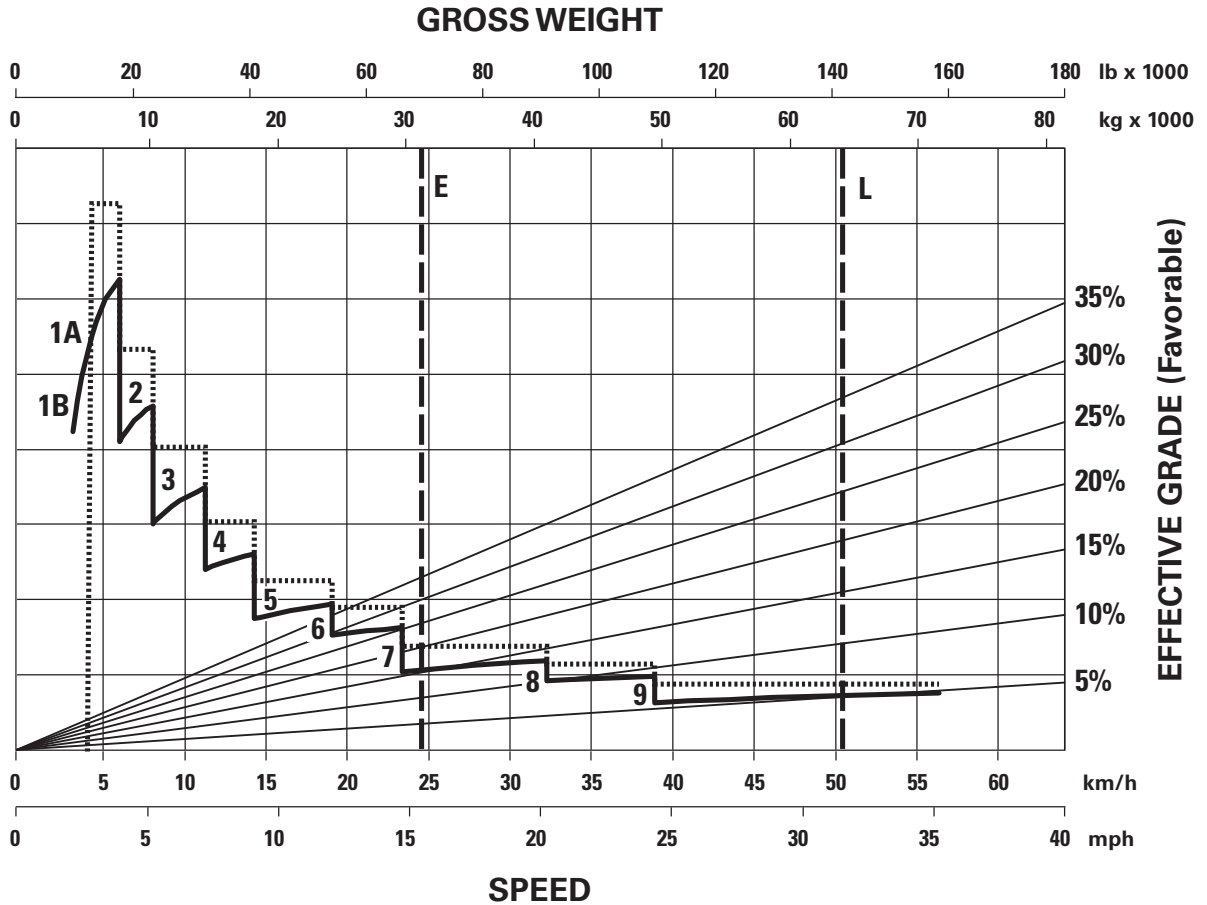

KEY

- 1A – 1st Gear (Converter Drive)
- 1B – 1st Gear (Direct Drive)
- 2 – 2nd Gear
- 3 – 3rd Gear
- 4 – 4th Gear
- 5 – 5th Gear
- 6 – 6th Gear
- 7 – 7th Gear
- 8 – 8th Gear
- 9 – 9th Gear

KEY

- E – Empty 31 400 kg (69,225 lb)
- L – Loaded 64 100 kg (141,316 lb)

● 26.5R25 Tires

● Tier 2/Stage II/Japan 2001 (Tier 2)

STANDARD*

GROSS WEIGHT

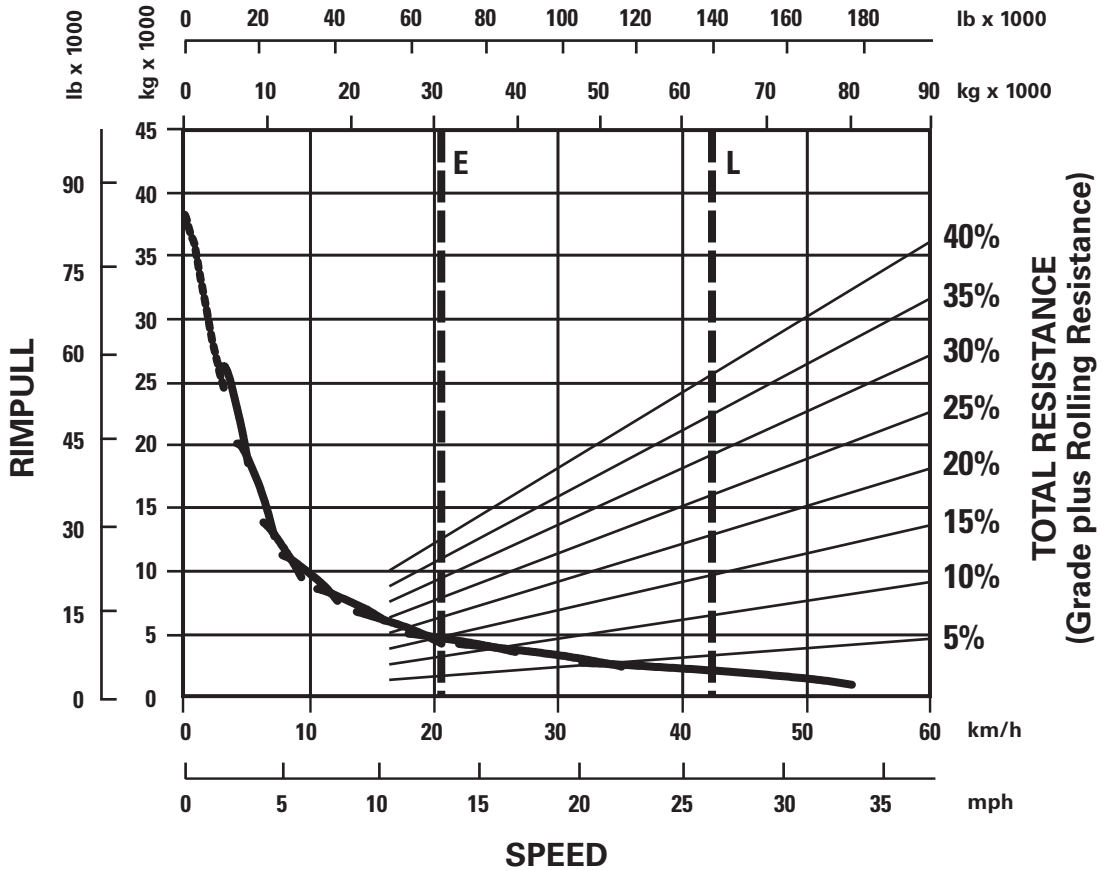

KEY

- E — Empty 31 220 kg (68,800 lb)
- L — Loaded 63 920 kg (140,900 lb)

*At sea level.

Articulated Trucks

735C Series Brake/Retarder Performance Curve

- 26.5R25Tires
- Tier 2/Stage II/Japan 2001 (Tier 2)

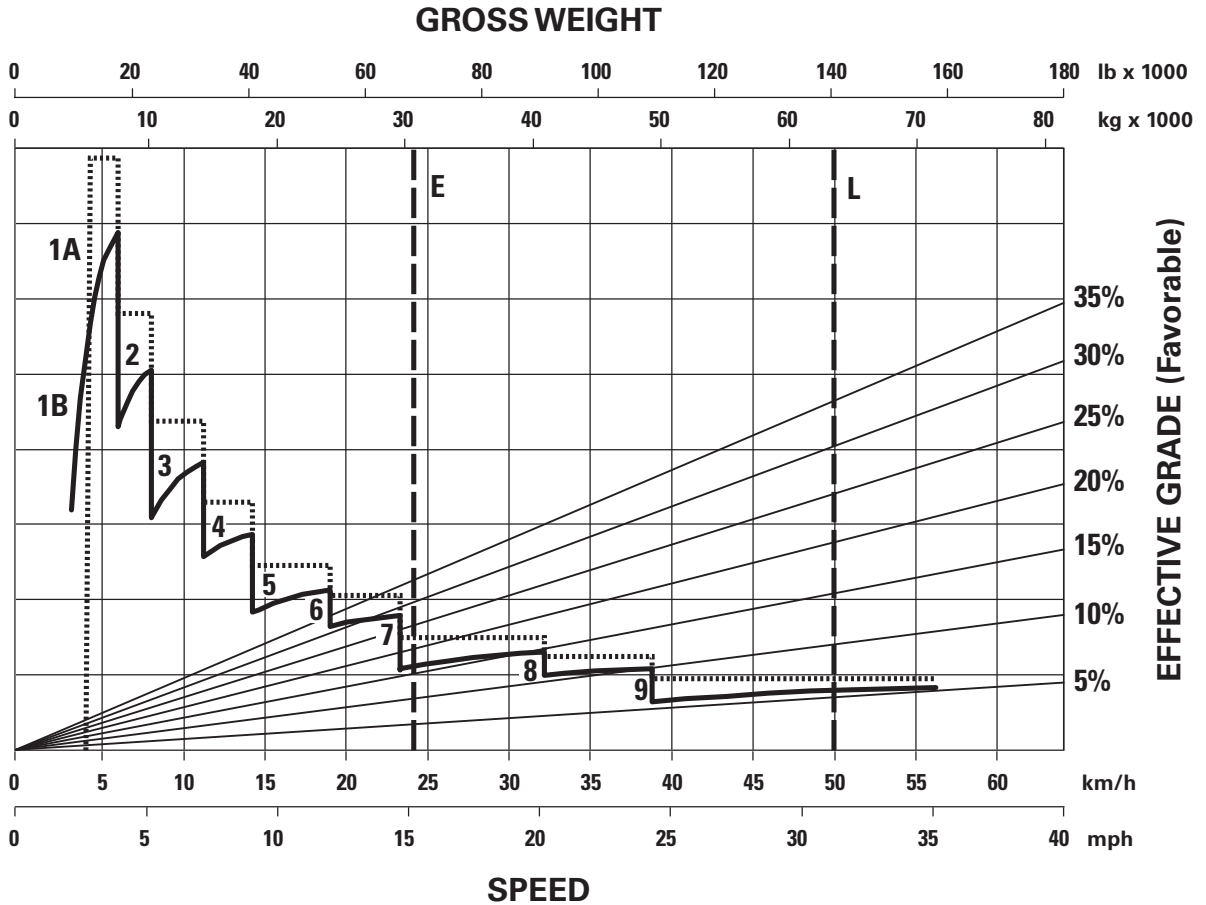

KEY

- 1A – 1st Gear (Converter Drive)
- 1B – 1st Gear (Direct Drive)
- 2 – 2nd Gear
- 3 – 3rd Gear
- 4 – 4th Gear
- 5 – 5th Gear
- 6 – 6th Gear
- 7 – 7th Gear
- 8 – 8th Gear
- 9 – 9th Gear

KEY

- E – Empty 30 970 kg (68,277 lb)
- L – Loaded 63 670 kg (140,368 lb)

● 29.5R25 Tires

● Tier 4 Final/Stage IV/Japan 2014 (Tier 4 Final)

STANDARD*

GROSS WEIGHT

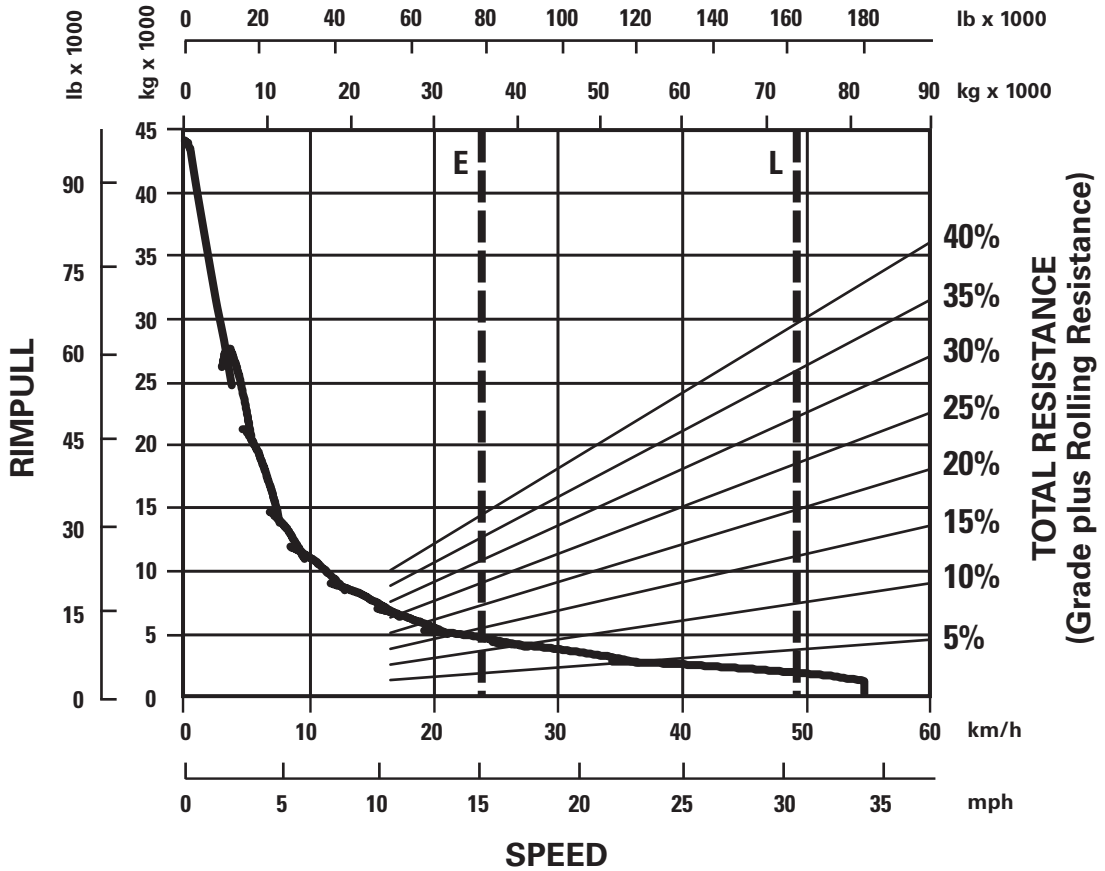

KEY

- E — Empty 36 000 kg (79,400 lb)
- L — Loaded 74 000 kg (163,100 lb)

*At sea level.

Articulated Trucks

740C EJ Series Brake/Retarder Performance Curve

- 29.5R25Tires
- Tier 4 Final/Stage IV/Japan 2014 (Tier 4 Final)

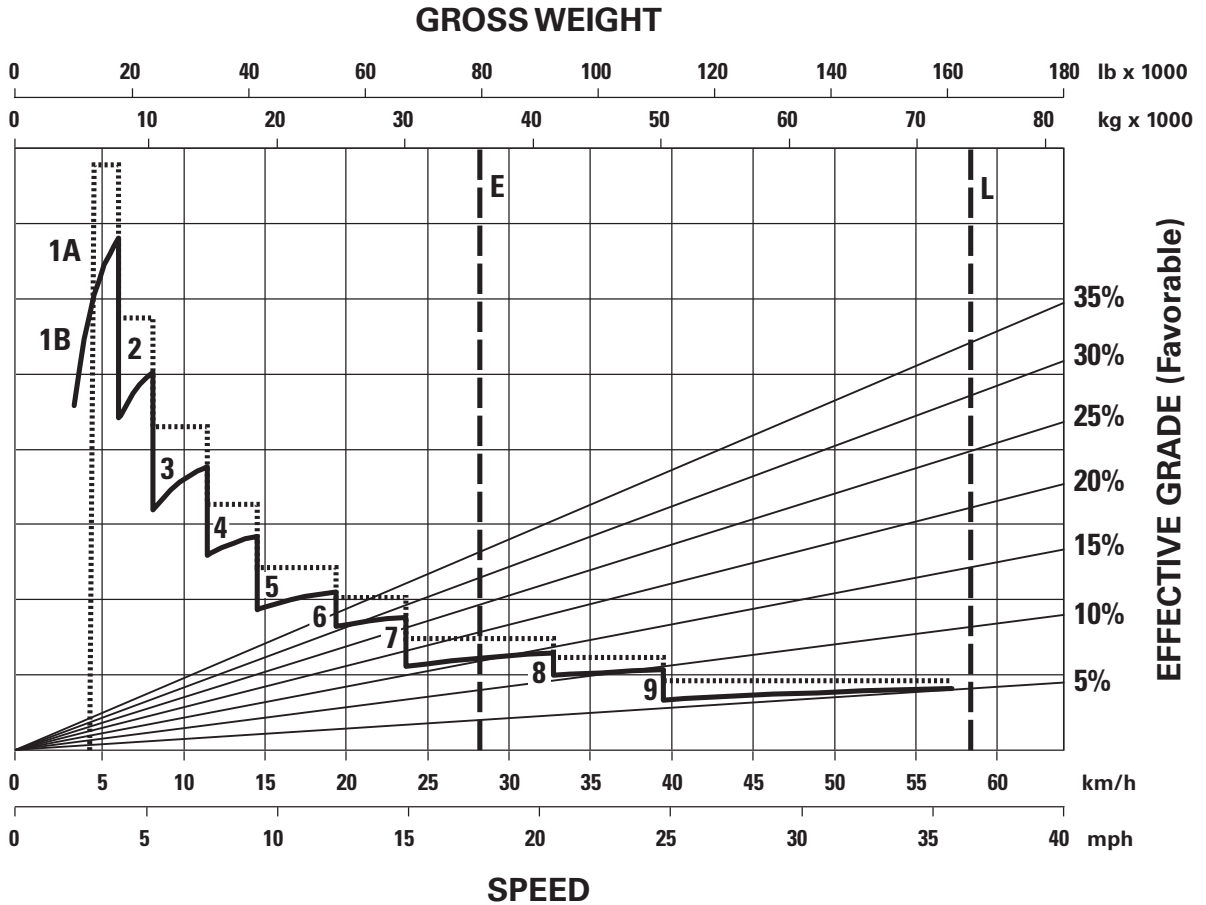

KEY

- 1A – 1st Gear (Converter Drive)
- 1B – 1st Gear (Direct Drive)
- 2 – 2nd Gear
- 3 – 3rd Gear
- 4 – 4th Gear
- 5 – 5th Gear
- 6 – 6th Gear
- 7 – 7th Gear
- 8 – 8th Gear
- 9 – 9th Gear

KEY

- E – Empty 36 070 kg (79,521 lb)
- L – Loaded 74 070 kg (163,296 lb)

● 29.5R25 Tires

● Tier 2/Stage II/Japan 2001 (Tier 2)

STANDARD*

GROSS WEIGHT

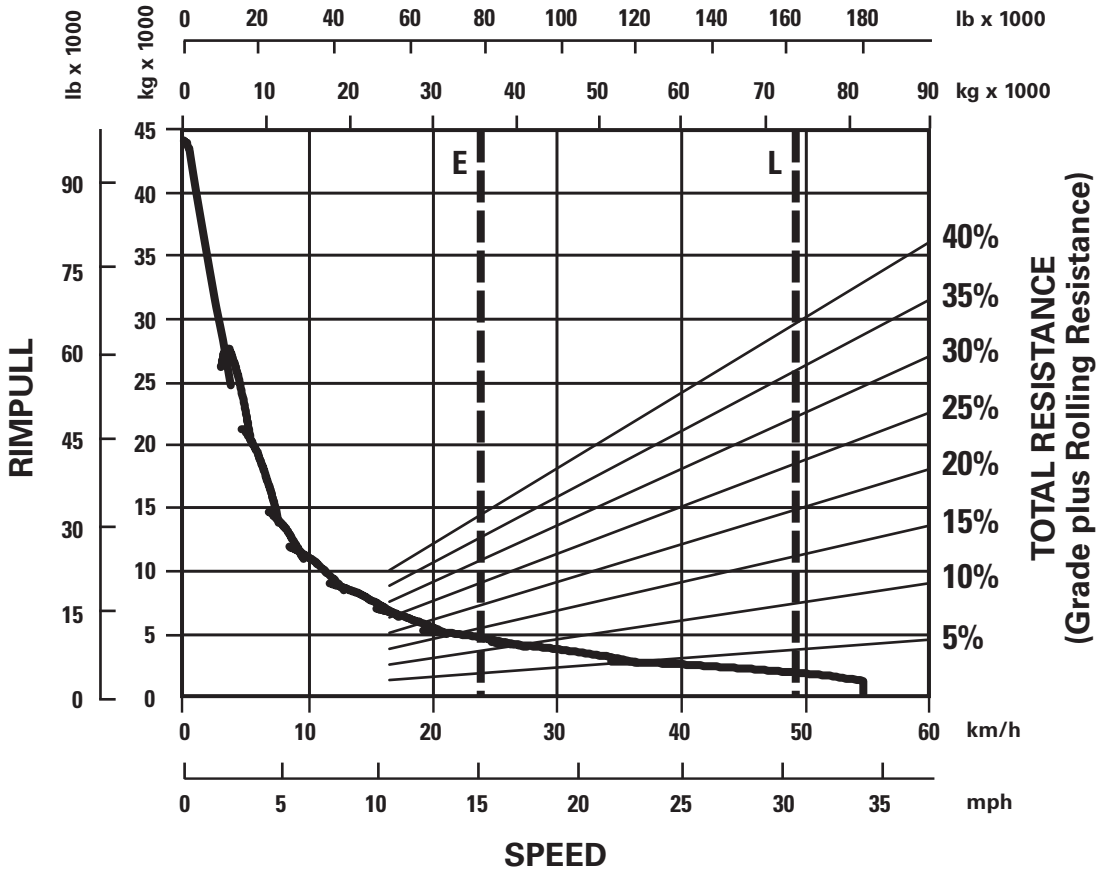

KEY

- E — Empty 36 000 kg (79,400 lb)
- L — Loaded 74 000 kg (163,100 lb)

*At sea level.

Articulated Trucks

740C EJ Series Brake/Retarder Performance Curve

- 29.5R25 Tires
- Tier 2/Stage II/Japan 2001 (Tier 2)

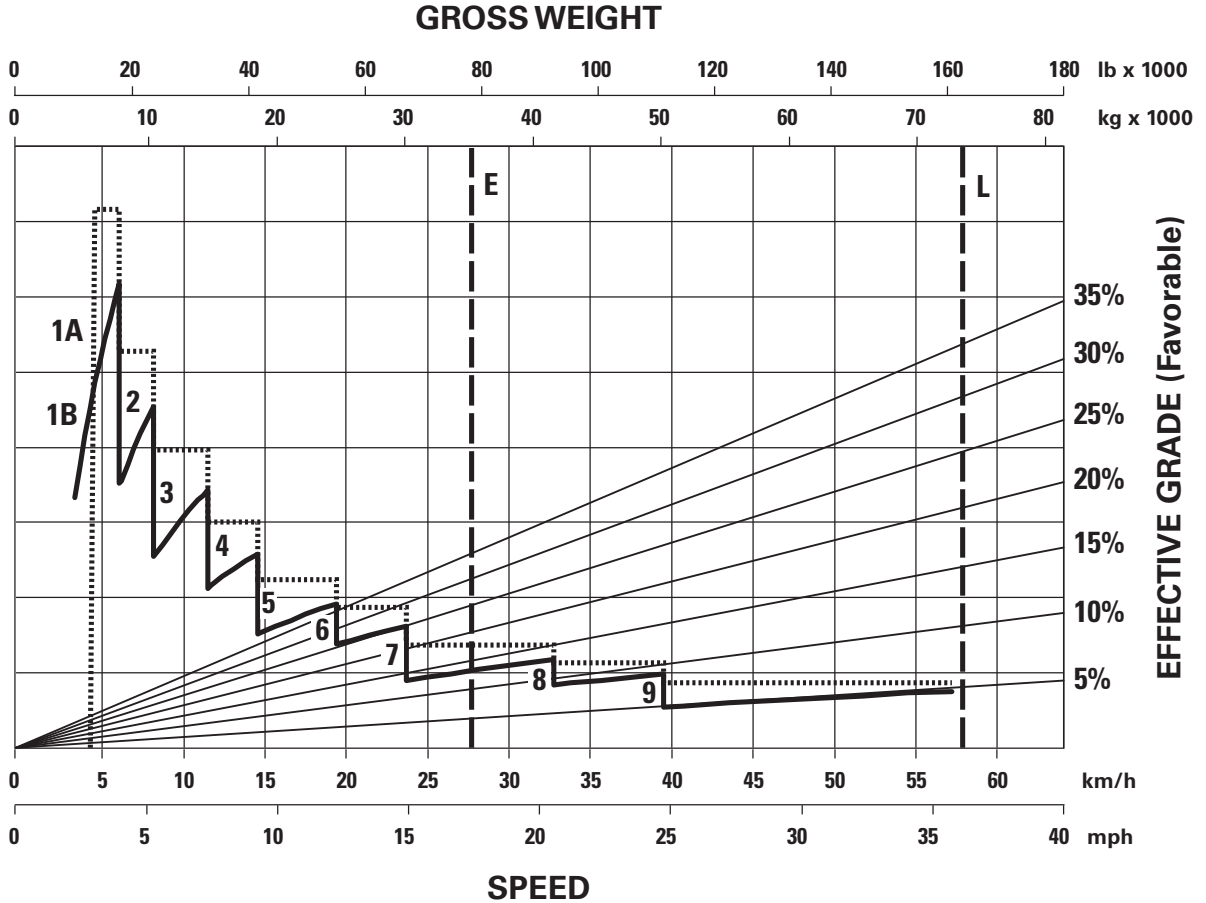

KEY

- 1A – 1st Gear (Converter Drive)
- 1B – 1st Gear (Direct Drive)
- 2 – 2nd Gear
- 3 – 3rd Gear
- 4 – 4th Gear
- 5 – 5th Gear
- 6 – 6th Gear
- 7 – 7th Gear
- 8 – 8th Gear
- 9 – 9th Gear

KEY

- E – Empty 35 540 kg (78,352 lb)
- L – Loaded 73 540 kg (162,128 lb)

● 29.5R25 Tires

● Tier 4 Final/Stage IV/Japan 2014 (Tier 4 Final)

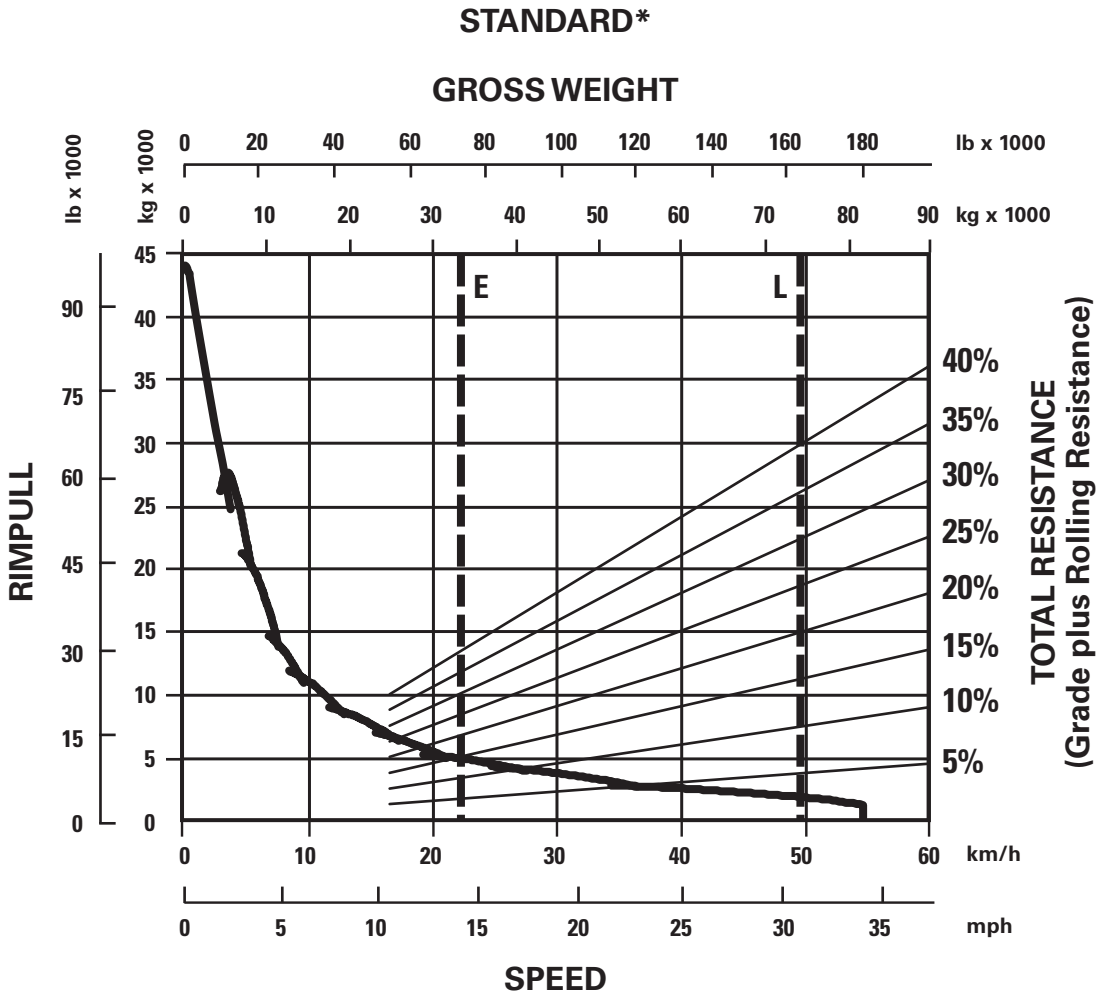

KEY

- E — Empty 33 600 kg (74,100 lb)
- L — Loaded 74 600 kg (164,500 lb)

*At sea level.

Articulated Trucks

745C Series Brake/Retarder Performance Curve

- 29.5R25 Tires
- Tier 4 Final/Stage IV/Japan 2014 (Tier 4 Final)

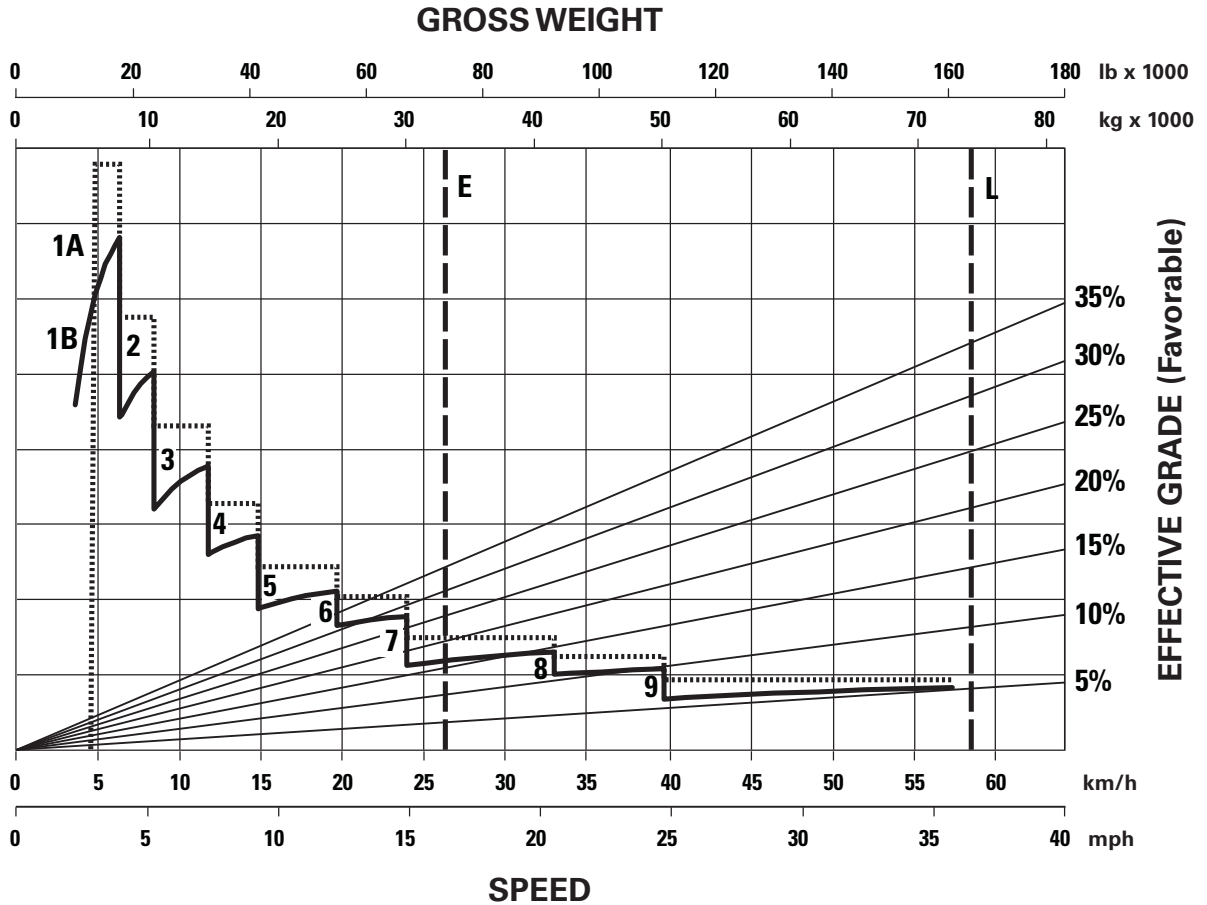

KEY

- 1A – 1st Gear (Converter Drive)
- 1B – 1st Gear (Direct Drive)
- 2 – 2nd Gear
- 3 – 3rd Gear
- 4 – 4th Gear
- 5 – 5th Gear
- 6 – 6th Gear
- 7 – 7th Gear
- 8 – 8th Gear
- 9 – 9th Gear

KEY

- E – Empty 33 400 kg (73,635 lb)
- L – Loaded 74 400 kg (164,024 lb)

● 29.5R25 Tires

● Tier 2/Stage II/Japan 2001 (Tier 2)

STANDARD*

GROSS WEIGHT

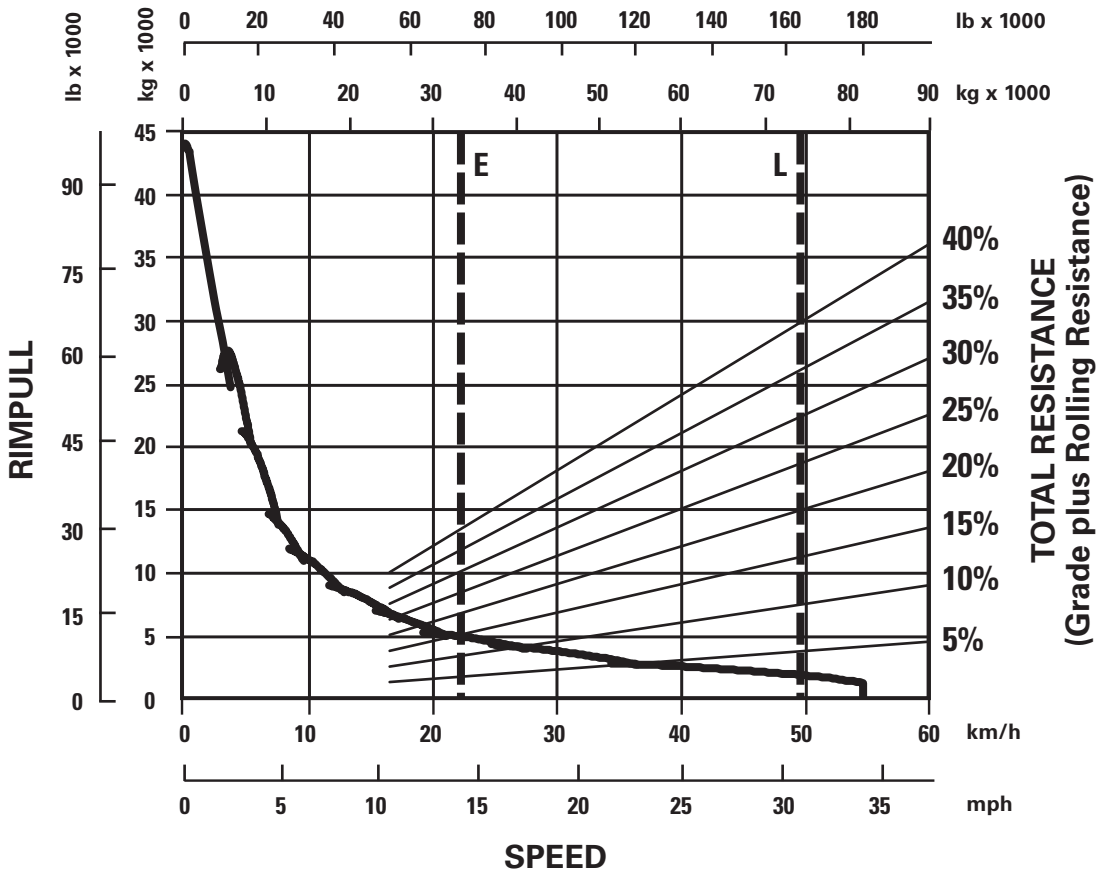

KEY

- E — Empty 33 600 kg (74,100 lb)
- L — Loaded 74 600 kg (164,500 lb)

*At sea level.

Articulated Trucks

745C Series Brake/Retarder Performance Curve

- 29.5R25Tires
- Tier 2/Stage II/Japan 2001 (Tier 2)

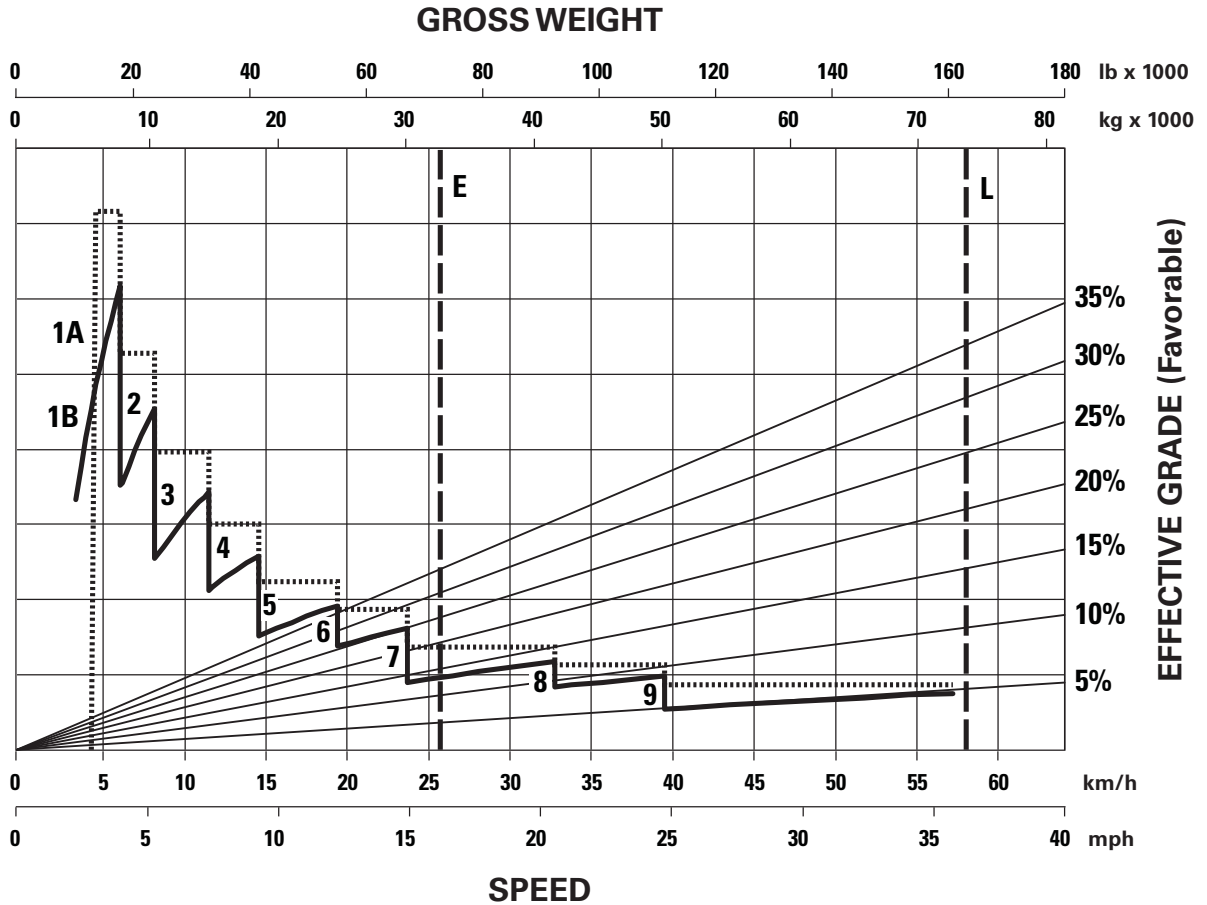

KEY

- 1A – 1st Gear (Converter Drive)
- 1B – 1st Gear (Direct Drive)
- 2 – 2nd Gear
- 3 – 3rd Gear
- 4 – 4th Gear
- 5 – 5th Gear
- 6 – 6th Gear
- 7 – 7th Gear
- 8 – 8th Gear
- 9 – 9th Gear

KEY

- E – Empty 32 870 kg (72,466 lb)
- L – Loaded 73 870 kg (162,855 lb)

BACKHOE LOADERS

CONTENTS

Features	2-1
Specifications	2-3
415F2/416F2:	
Performance Data	2-7
Lift Capacities	2-10
420F2/420F2 IT:	
Performance Data	2-13
Lift Capacities	2-21
422F2:	
Performance Data	2-24
Lift Capacities	2-26
427F2/428F2:	
Performance Data	2-29
Lift Capacities	2-33
430F2/430F2 IT:	
Performance Data	2-36
Lift Capacities	2-43
432F2:	
Performance Data	2-46
Lift Capacities	2-50
434F2:	
Performance Data	2-55
Lift Capacities	2-58
444F2:	
Performance Data	2-61
Lift Capacities	2-66
450F:	
Performance Data	2-71
Lift Capacities	2-74
Backhoe Bucket Capacities	2-75
Work Tools	2-77

Features:

- **Center pivot backhoe** — 415F2, 416F2, 420F2, 430F2, 450F.
- **Side shift backhoe** — 422F2, 427F2, 428F2, 432F2, 434F2, 444F2.
- **Single-tilt loader** features a narrow loader tower and single bucket tilt cylinder for improved visibility.
- **Integrated toolcarrier (parallel lift) loader** offers maximum lift and breakout forces and parallel lift for efficient loading and material handling.
 - **Hydraulic Quick Coupler** provides versatility and allows quick connection to selected work tools for the Cat® family of integrated toolcarriers.
- **Excavator-style backhoe** provides enhanced visibility even with narrow buckets, ability to reach over obstacles, and faster, easier truck loading.
 - **Backhoe Quick Coupler** offerings include a convenient “pin grabber” and versatile “pin puller” for use with D/E/F Series and competitive work tools.
- **Load-sensing hydraulic system** provides full hydraulic torque to implements at all engine speeds, low fuel consumption, smooth control and low lever efforts. An electronic torque limiter automatically optimizes hydraulics.

For product support, sales and marketing support information and business tools to help improve business functions and processes for Cat dealers, click on the link below. For Backhoe Loaders and other Cat machines select Machines under the Product tab.

dealer.cat.com

- **Pilot operated backhoe controls** provide smooth, efficient operation and operator comfort. Not available on 422F2, 427F2, 428F2, 434F2. New thumb roller controllers provide ergonomic function of the extendible stick and/or auxiliary hydraulic circuits. Convenient pattern changer switch is within the cab.
- **Pilot operated stabilizer controls** are standard on 420F2, 430F2, 432F2, 444F2, 450F. Auto-up stabilizers are standard with the deluxe cab.
- **The Cat C3.4 and C4.4 ACERT™ Direct Injection Turbocharged Aftercooled engines** meet U.S. EPA Tier 4 Final/EU Stage IV/Japan 2014 (Tier 4 Final) emission standards. The efficient fuel system delivers reliable engine lug performance. Some models are powered with Cat 3054C DIT engines, which meet Tier 2/Stage II/Japan 2001 (Tier 2) equivalent emission standards.
- **XT™-3 ES hoses** combined with Cat couplings and O-ring face seal fittings provide a dry, reliable machine. The E Series backhoe circuits incorporate the XT-3 ES ToughGuard™ hoses.
- **Operator station features:** Air-suspension seat is standard on all models. Adjustable tilt steering is standard except on 415F2, 416F2, 422F2. Rear, door and side windows can be fully opened for enhanced ventilation and cab roof is extended to help keep operator dry. Four-post Rollover Protective Structure (ROPS) for increased protection. Fully featured, a Deluxe Cab option will feature pilot operated joystick controls, state-of-the-art control panels with white-faced gauges mounted in a rotating vandal cover, pilot operated stabilizer controls with automatic hold upon lifting, and additional system monitoring including service indicators for engine air cleaner, water-in-fuel, and hydraulic filter.
- **High performance backhoe linkage** offers 205° of bucket rotation with one pin position. Backhoe geometry creates more stick force than previous series, brought closer to the operator to pull spoil through trench. The 450F has a backhoe bucket rotation of 198°.
- **Diagonal Retention System (DRS)** standard on all factory installed buckets with weld-on tooth adapters, excluding the 450F. Bucket teeth are attached with diagonal pins rather than horizontal pins for easy exchange of bucket teeth. 450F buckets remain fitted with J225 size, horizontal fastener pins. All other buckets have bolt-on Uni-teeth.
- **Integrated lift eye** on backhoe linkage. Object handling installation available on 427F2, 428F2, 432F2, 434F2, 444F2 for EU countries.
- **Cat Cushion Swing** system smooths the swing function, improving the return-to-trench controllability.
- **The extendible stick** on 415F2, 416F2, 420F2, 430F2 and 450F offers object clamping while extending. Ser-rated edges secure clamped objects. Wear pad configuration eases adjustment on all four sliding surfaces. Center pivot sticks have thumb mounts.
- **The hydraulic system** uses load sensing, flow sharing valves with anti-drift characteristics. Smooth, multi-function operation with the ability to have maximum lifting and digging forces at any RPM.
- **Ride Control** available as an option on all F Series machines. The Ride-Control system smooths the ride under all job-site conditions.
- **4F/4R fully synchronized gear box** provides on-the-go shifting in all gears and on-the-go engagement of optional all wheel drive. Maximum travel speed is 40 km/h (25 mph).
- **Auto-Shift transmission** is available as an option on F2 Series and is standard on 444F2 and 450F for operator comfort and efficiency. This transmission is equipped with 6F/3R power shift gear box.
- **Lock-up torque converter** available as an option on 420F2, 430F2, 428F2, 434F2, 434F2 and 444F2 for improved efficiency.
- **Brakes** are oil immersed, multi-disc, self adjusting, and wear surface is made of Kevlar for long service life. Brakes are boosted on all models.
- **All Wheel Drive** is available as an option on all E and F Series machines, standard on 430F2, 434F2, 444F2 and 450F. It improves mobility and loader performance in poor traction conditions and can be engaged at any time in any operating condition. Includes 4-wheel braking effect feature.
- **Sloping, flip-open multi-access hood** allows excellent visibility to the loader working area and tilts forward for single location access to all daily service points.
- **Dry-type, radial seal air cleaner** with automatic, integrated dust ejector system provides efficient pre-separation. The two-stage air filter incorporates both air cleaner and pre-cleaner functions into a single unit mounted under the hood.

MODEL	415F2		416F2		420F2/420F2 IT	
Flywheel Power						
Gross — Tier 4 Final/Stage IV/Japan 2014 (Tier 4 Final)	55 kW	74 hp	70 kW	94 hp	74 kW	100 hp
Net — Tier 4 Final/Stage IV/Japan 2014 (Tier 4 Final)	51 kW	68 hp	66 kW	89 hp	70 kW	94 hp
Gross — Tier 3/Stage IIIA/Japan 2006 (Tier 3) equivalent	—	—	70 kW	94 hp	75 kW	101 hp
Net — Tier 3/Stage IIIA/Japan 2006 (Tier 3) equivalent	—	—	65 kW	87 hp	71 kW	95 hp
Gross — Tier 2/Stage II/Japan 2001 (Tier 2) equivalent	—	—	68 kW	92 hp	74 kW	99 hp
Net — Tier 2/Stage II/Japan 2001 (Tier 2) equivalent	—	—	65 kW	87 hp	71 kW	95 hp
Net Torque Rise at 1400 rpm						
Tier 4 Final/Stage IV/Japan 2014 (Tier 4 Final)	88% (@1200 rpm)		56%		46%	
Tier 3/Stage IIIA/Japan 2006 (Tier 3) equivalent	—		37%		32%	
Tier 2/Stage II/Japan 2001 (Tier 2) equivalent	—		38%		31%	
Peak Torque at 1400 rpm						
Tier 4 Final/Stage IV/Japan 2014 (Tier 4 Final)	416 N·m	307 lbf-ft	439 N·m	324 lbf-ft	438 N·m	323 lbf-ft
Tier 3/Stage IIIA/Japan 2006 (Tier 3) equivalent	—		383 N·m	282 lbf-ft	398 N·m	294 lbf-ft
Tier 2/Stage II/Japan 2001 (Tier 2) equivalent	—		384 N·m	283 lbf-ft	397 N·m	293 lbf-ft
Operating Weight	7171 kg	15,809 lb	7487 kg	16,506 lb	7726 kg	17,033 lb
Engine Model	C3.4 ACERT		C4.4 ACERT		C4.4 ACERT	
			3054C		3054C	
Rated Engine RPM	2200		2200		2200	
No. of Cylinders	4		4		4	
Bore	99 mm	3.90 in	105 mm	4.13 in	105 mm	4.13 in
Stroke	110 mm	4.33 in	127 mm	5.00 in	127 mm	5.00 in
Displacement	3.4 L	207 in³	4.4 L	268 in³	4.4 L	268 in³
Speeds (Manual)	km/h	mph	km/h	mph	km/h	mph
1st	5	3	5	3	5	3
2nd	9	6	9	6	9	6
3rd	20	13	20	13	21	13
4th	36	23	36	23	38	24
Speeds (Auto-Shift)						
1st	—	—	—	—	6	4
2nd	—	—	—	—	9	6
3rd	—	—	—	—	12	7
4th	—	—	—	—	19	12
5th	—	—	—	—	23	14
5th LUC (if equipped)	—	—	—	—	25	15
6th	—	—	—	—	40	25
6th LUC (if equipped)	—	—	—	—	40	25
Turning Circle, Wall to Wall	11.0 m	36'0"	11.0 m	36'0"	11.0 m	36'0"
Tires						
2WD Bias Front	12-16.5 10 PR F-3		12-16.5 10 PR F-3		12-16.5 10 PR F-3	
2WD Bias Rear	19.5L-24 12 PR R-4		19.5L-24 12 PR R-4		19.5L-24 12 PR R-4	
AWD Bias Front	12.5/80-18 12 PR I-3		12.5/80-18 12 PR I-3		12.5/80-18 12 PR I-3	
AWD Bias Rear	19.5L-24 12 PR R-4		19.5L-24 12 PR R-4		19.5L-24 12 PR R-4	
AWD Bias Front, Flotation	12.5/80-18 12 PR I-3		12.5/80-18 12 PR I-3		12.5/80-18 12 PR I-3	
AWD Bias Rear, Flotation	21L-24 16 PR R-4		21L-24 16 PR R-4		21L-24 16 PR R-4	
AWD Radial Front	340/80R18		340/80R18		340/80R18	
AWD Radial Rear	500/70R24		500/70R24		500/70R24	
AWD Combination Front	340/80R18		340/80R18		340/80R18	
AWD Combination Rear	19.5L-24 12 PR R-4		19.5L-24 12 PR R-4		19.5L-24 12 PR R-4	
Hydraulic System, closed center	Load Sensing, Flow Sharing		Load Sensing, Flow Sharing		Load Sensing, Flow Sharing	
Pump Capacity	125 L/min @ 2200 rpm	@ 23 000 kPa	125 L/min @ 2200 rpm	@ 23 000 kPa	150 L/min @ 2200 rpm	@ 25 000 kPa
	33 gpm @ 2200 rpm	@ 3336 psi	33 gpm @ 2200 rpm	@ 3336 psi	40 gpm @ 2200 rpm	@ 3626 psi
Fuel Tank Capacity	160 L	42 U.S. gal	160 L	42 U.S. gal	160 L	42 U.S. gal

MODEL	422F2*		427F2		428F2*	
Flywheel Power						
Gross — Tier 4 Final/Stage IV/Japan 2014 (Tier 4 Final)	—		55 kW	74 hp	70 kW	94 hp
Net — Tier 4 Final/Stage IV/Japan 2014 (Tier 4 Final)	—		51 kW	68 hp	66 kW	88 hp
Gross — Tier 3/Stage IIIA/Japan 2006 (Tier 3) equivalent	—		—		70/75 kW	94/100 hp
Net — Tier 3/Stage IIIA/Japan 2006 (Tier 3) equivalent	—		—		65/70 kW	87/94 hp
Gross — Tier 2/Stage II/Japan 2001 (Tier 2) equivalent	56/68 kW	76/92 hp	—		68/74 kW	92/100 hp
Net — Tier 2/Stage II/Japan 2001 (Tier 2) equivalent	53/65 kW	71/87 hp	—		65/71 kW	87/95 hp
Net Torque Rise at 1400 rpm						
Tier 4 Final/Stage IV/Japan 2014 (Tier 4 Final)	—		88% (@1200 rpm)		56%	
Tier 3/Stage IIIA/Japan 2006 (Tier 3) equivalent	—		—		37/32%	
Tier 2/Stage II/Japan 2001 (Tier 2) equivalent	27/38%		—		38/31%	
Peak Torque at 1400 rpm						
Tier 4 Final/Stage IV/Japan 2014 (Tier 4 Final)	—		416 N·m	307 lbf-ft	439 N·m	324 lbf-ft
Tier 3/Stage IIIA/Japan 2006 (Tier 3) equivalent	—		—		383/398 N·m	282/294 lbf-ft
Tier 2/Stage II/Japan 2001 (Tier 2) equivalent	288/384 N·m	212/283 lbf-ft	—		384/397 N·m	283/293 lbf-ft
Operating Weight	7529 kg	16,601 lb	8108 kg	17,878 lb	8425 kg	18,577 lb
Engine Model	3054C DINA		C3.4 ACERT		C4.4 ACERT	
Rated Engine RPM	3054C		3054C		3054C	
No. of Cylinders	2200		2200		2200	
Bore	4		4		4	
Stroke	105 mm	4.13 in	99 mm	3.90 in	105 mm	4.13 in
Displacement	127 mm	5.00 in	110 mm	4.33 in	127 mm	5.00 in
Speeds (Manual)	4.4 L	268 in³	3.4 L	207 in³	4.4 L	268 in³
1st	km/h	mph	km/h	mph	km/h	mph
2nd	6	3	6	4	6	4
3rd	9	6	9	6	9	6
4th	21	13	21	13	21	13
Speeds (Auto-Shift)	37	23	37	23	37	23
1st	—	—	6	4	6	4
2nd	—	—	10	6	10	6
3rd	—	—	12	8	12	8
4th	—	—	20	12	20	12
5th	—	—	24	15	24	15
5th LUC (if equipped)	—	—	25	16	25	16
6th	—	—	40	25	40	25
6th LUC (if equipped)	—	—	40	25	40	25
Turning Circle, Wall to Wall	11.0 m	36'0"	11.0 m	36'0"	11.0 m	36'0"
Tires						
2WD Bias Front	11-16 12 PR F-3		—		—	
2WD Bias Rear	16.9-28 12 PR R-4		—		—	
AWD Bias Front	12.5/80-18 12 PR I-3		12.5/80-18 10 PR I-3		12.5/80-18 10 PR I-3	
AWD Bias Rear	16.9-28 12 PR R-4		16.9-28 12 PR R4		16.9-28 12 PR R4	
AWD Radial Front	340/80R18		340/80R18		340/80R18	
AWD Radial Rear	440/80R28		440/80R28		440/80R28	
Hydraulic System, closed center	Load Sensing, Flow Sharing		Load Sensing, Flow Sharing		Load Sensing, Flow Sharing	
Pump Capacity	125 L/min @ 2200 rpm @ 23 000 kPa	33 gpm @ 2200 rpm @ 3336 psi	150 L/min @ 2200 rpm @ 25 000 kPa	40 gpm @ 2200 rpm @ 3626 psi	150 L/min @ 2200 rpm @ 25 000 kPa	40 gpm @ 2200 rpm @ 3626 psi
Fuel Tank Capacity	160 L	42 U.S. gal	160 L	42 U.S. gal	160 L	42 U.S. gal

*Multiple engine power ratings available.

MODEL	430F2/430F2 IT		432F2*		434F2*	
Flywheel Power						
Gross — Tier 4 Final/Stage IV/Japan 2014 (Tier 4 Final)	86 kW	115 hp	74/82 kW	100/110 hp	74 kW	100 hp
Net — Tier 4 Final/Stage IV/Japan 2014 (Tier 4 Final)	82 kW	109 hp	70/78 kW	94/104 hp	70 kW	94 hp
Gross — Tier 3/Stage IIIA/Japan 2006 (Tier 3) equivalent	75 kW	100 hp	75 kW	101 hp	75 kW	100 hp
Net — Tier 3/Stage IIIA/Japan 2006 (Tier 3) equivalent	70 kW	94 hp	71 kW	95 hp	70 kW	94 hp
Gross — Tier 2/Stage II/Japan 2001 (Tier 2) equivalent	74 kW	100 hp	74 kW	100 hp	68/74 kW	92/100 hp
Net — Tier 2/Stage II/Japan 2001 (Tier 2) equivalent	71 kW	95 hp	71 kW	95 hp	65/71 kW	87/95 hp
Net Torque Rise at 1400 rpm						
Tier 4 Final/Stage IV/Japan 2014 (Tier 4 Final)		39%		46/32%		46%
Tier 3/Stage IIIA/Japan 2006 (Tier 3) equivalent		32%		32%		32%
Tier 2/Stage II/Japan 2001 (Tier 2) equivalent		31%		31%		38/31%
Peak Torque at 1400 rpm						
Tier 4 Final/Stage IV/Japan 2014 (Tier 4 Final)	488 N·m	360 lbf-ft	438/439 N·m	323/324 lbf-ft	438 N·m	323 lbf-ft
Tier 3/Stage IIIA/Japan 2006 (Tier 3) equivalent	398 N·m	294 lbf-ft	399 N·m	294 lbf-ft	398 N·m	294 lbf-ft
Tier 2/Stage II/Japan 2001 (Tier 2) equivalent	397 N·m	293 lbf-ft	397 N·m	293 lbf-ft	384/397 N·m	283/293 lbf-ft
Operating Weight	8330 kg	18,364 lb	8479 kg	18,696 lb	9257 kg	20,408 lb
Engine Model	C4.4 ACERT 3054C		C4.4 ACERT 3054C		C4.4 ACERT 3054C	
Rated Engine RPM	2200		2200		2200	
No. of Cylinders	4		4		4	
Bore	105 mm	4.13 in	105 mm	4.13 in	105 mm	4.13 in
Stroke	127 mm	5.00 in	127 mm	5.00 in	127 mm	5.00 in
Displacement	4.4 L	268 in³	4.4 L	268 in³	4.4 L	268 in³
Speeds (Manual)	km/h	mph	km/h	mph	km/h	mph
1st	5	3	6	4	6	3
2nd	9	6	9	6	9	6
3rd	21	13	22	13	21	13
4th	38	24	40	25	36	22
Speeds (Auto-Shift)						
1st	6	4	6	4	6	4
2nd	9	6	10	6	10	6
3rd	12	8	13	8	12	8
4th	19	12	20	12	20	12
5th	23	14	24	15	24	15
5th LUC (if equipped)	25	15	26	16	26	16
6th	40	25	40	25	40	25
6th LUC (if equipped)	40	25	40	25	40	25
Turning Circle, Wall to Wall	11.0 m	36'0"	11.0 m	36'0"	12.6 m	41'4"
Tires						
AWD Bias Front	12.5/80-18 12 PR I-3		12.5/80-18 10 PR I-3		—	
AWD Bias Rear	19.5L-24 12 PR R4		16.9-28 12 PR R4		—	
AWD Bias Front, Flotation	12.5/80-18 12 PR I-3		—		—	
AWD Bias Rear, Flotation	21L-24 16 PR		—		—	
AWD Radial Front	340/80R18		340/80R18		440/80R24	
AWD Radial Rear	500/70R24		440/80R28		440/80R24	
AWD Combination Front	340/80R18 XMCL		—		—	
AWD Combination Rear	19.5L-24 12 PR R4		—		—	
Hydraulic System, closed center	Load Sensing, Flow Sharing		Load Sensing, Flow Sharing		Load Sensing, Flow Sharing	
Pump Capacity	150 L/min @ 2200 rpm @ 25 000 kPa	40 gpm @ 2200 rpm @ 3626 psi	150 L/min @ 2200 rpm @ 25 000 kPa	40 gpm @ 2200 rpm @ 3626 psi	150 L/min @ 2200 rpm @ 25 000 kPa	40 gpm @ 2200 rpm @ 3626 psi
Fuel Tank Capacity	160 L	42 U.S. gal	160 L	42 U.S. gal	160 L	42 U.S. gal

*Multiple engine power ratings available.

MODEL	444F2*		450F	
Flywheel Power				
Gross — Tier 4 Final/Stage IV/Japan 2014 (Tier 4 Final)	74/82 kW	100/110 hp	106 kW**	142 hp**
Net — Tier 4 Final/Stage IV/Japan 2014 (Tier 4 Final)	70/78 kW	94/104 hp	96 kW**	128 hp**
Gross — Tier 3/Stage IIIA/Japan 2006 (Tier 3) equivalent	75 kW	100 hp	—	—
Net — Tier 3/Stage IIIA/Japan 2006 (Tier 3) equivalent	70 kW	94 hp	—	—
Gross — Tier 2/Stage II/Japan 2001 (Tier 2) equivalent	74 kW	100 hp	—	—
Net — Tier 2/Stage II/Japan 2001 (Tier 2) equivalent	71 kW	95 hp	—	—
Net Torque Rise at 1400 rpm				
Tier 4 Final/Stage IV/Japan 2014 (Tier 4 Final)		46/32%		31%**
Tier 3/Stage IIIA/Japan 2006 (Tier 3) equivalent		32%		—
Tier 2/Stage II/Japan 2001 (Tier 2) equivalent		31%		—
Peak Torque at 1400 rpm				
Tier 4 Final/Stage IV/Japan 2014 (Tier 4 Final)	438/439 N·m	323/324 lbf-ft	542 N·m**	413 lbf-ft**
Tier 3/Stage IIIA/Japan 2006 (Tier 3) equivalent	398 N·m	294 lbf-ft	—	—
Tier 2/Stage II/Japan 2001 (Tier 2) equivalent	397 N·m	293 lbf-ft	—	—
Operating Weight	9606 kg	21,178 lb	11 283 kg	24,875 lb
Engine Model	C4.4 ACERT		C4.4 ACERT**	
	3054C			
Rated Engine RPM	2200		2200	
No. of Cylinders	4		4	
Bore	105 mm	4.13 in	105 mm	4.13 in
Stroke	127 mm	5.00 in	127 mm	5.00 in
Displacement	4.4 L	268 in³	4.4 L	268 in³
Speeds (Auto-Shift)	km/h	mph	km/h	mph
1st	6	4	6	4
2nd	10	6	10	6
3rd	12	8	20	12
4th	20	12	27	17
5th	24	15	40	25
5th LUC (if equipped)	25	16	—	—
6th	40	25	—	—
6th LUC (if equipped)	40	25	—	—
Turning Circle, Wall to Wall	12.6 m	41'4"	11.2 m	36'8"
Tires				
AWD Bias Front	—	—	15-19.5 12 PR	—
AWD Bias Rear	—	—	21L-24 18 PR R-4	—
AWD Radial Front	440/80R28	—	—	—
AWD Radial Rear	440/80R28	—	—	—
Hydraulic System, closed center	Load Sensing, Flow Sharing		Load Sensing, Flow Sharing	
Pump Capacity	150 L/min @ 2200 rpm	—	185 L/min @ 2200 rpm	—
	@ 25 000 kPa	—	@ 25 000 kPa	—
	40 gpm @ 2200 rpm	—	48 gpm @ 2200 rpm	—
	@ 3626 psi	—	@ 3626 psi	—
Fuel Tank Capacity	160 L	42 U.S. gal	160 L	42 U.S. gal

*Multiple engine power ratings available.
 **The 450F engine meets U.S. EPA Tier 4 Interim/EU Stage IIIB emission standards only.

Single-Tilt Loader

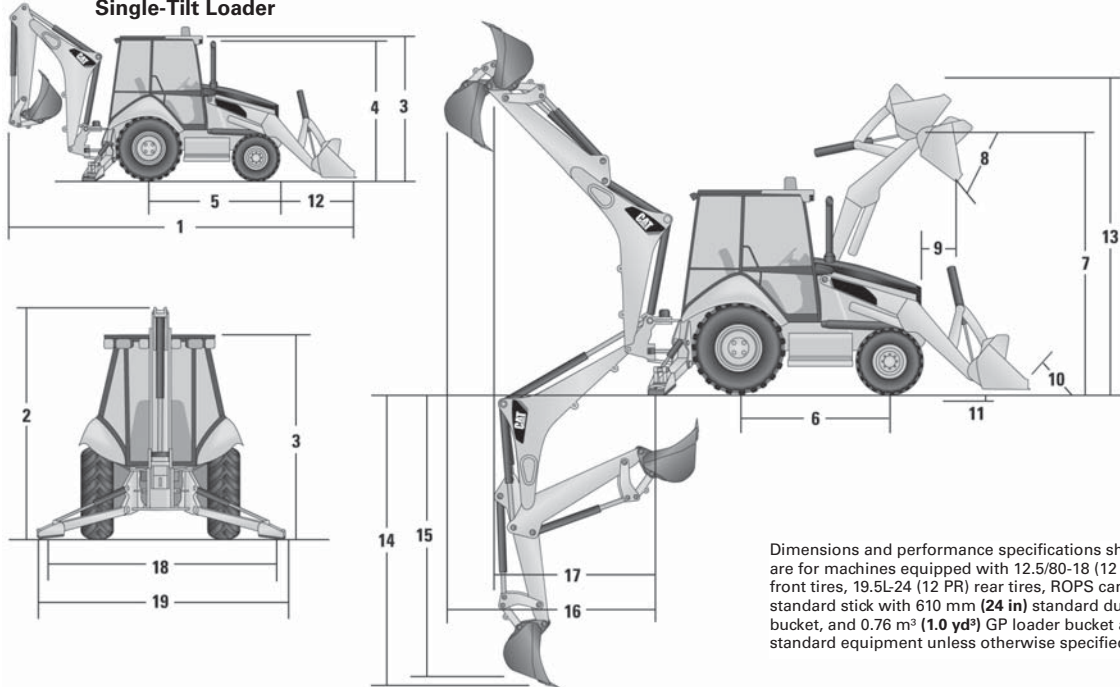

Dimensions and performance specifications shown are for machines equipped with 12.5/80-18 (12 PR) front tires, 19.5L-24 (12 PR) rear tires, ROPS canopy, standard stick with 610 mm (24 in) standard duty bucket, and 0.76 m³ (1.0 yd³) GP loader bucket and standard equipment unless otherwise specified.

MACHINE DIMENSIONS	Single-Tilt Loader							
	General Purpose 0.76 m ³ (1.0 yd ³)		General Purpose 0.96 m ³ (1.25 yd ³)		Multi Purpose 1.0 m ³ (1.31 yd ³)		Multi Purpose with Forks 1.0 m ³ (1.31 yd ³)	
1) Overall transport length	7085 mm	23'3"	7168 mm	23'6"	7132 mm	23'5"	7132 mm	23'5"
Overall length	7027 mm	23'1"	7140 mm	23'5"	7057 mm	23'2"	7057 mm	23'2"
2) Overall transport height S-stick	3577 mm	11'9"	3577 mm	11'9"	3577 mm	11'9"	3577 mm	11'9"
Overall transport height E-stick	3631 mm	11'11"	3631 mm	11'11"	3631 mm	11'11"	3631 mm	11'11"
Overall width	2322 mm	7'7"	2322 mm	7'7"	2322 mm	7'7"	2322 mm	7'7"
3) Height to top of cab/canopy	2819 mm	9'3"	2819 mm	9'3"	2819 mm	9'3"	2819 mm	9'3"
4) Height to top of exhaust stack	2744 mm	9'0"	2744 mm	9'0"	2744 mm	9'0"	2744 mm	9'0"
Ground clearance (LH step)	294 mm	1'0"	294 mm	1'0"	294 mm	1'0"	294 mm	1'0"
Ground clearance (AWD guard)	294 mm	1'0"	294 mm	1'0"	294 mm	1'0"	294 mm	1'0"
Ground clearance (485 kg/ 1170 lb counterweight)	274 mm	11"	274 mm	11"	274 mm	11"	274 mm	11"
5) Rear axle centerline to front grill	2705 mm	8'10"	2705 mm	8'10"	2705 mm	8'10"	2705 mm	8'10"
Front wheel tread gauge	1895 mm	6'3"	1895 mm	6'3"	1895 mm	6'3"	1895 mm	6'3"
Rear wheel tread gauge	1714 mm	5'7"	1714 mm	5'7"	1714 mm	5'7"	1714 mm	5'7"
6) Wheelbase (2WD/AWD)	2200 mm	7'3"	2200 mm	7'3"	2200 mm	7'3"	2200 mm	7'3"

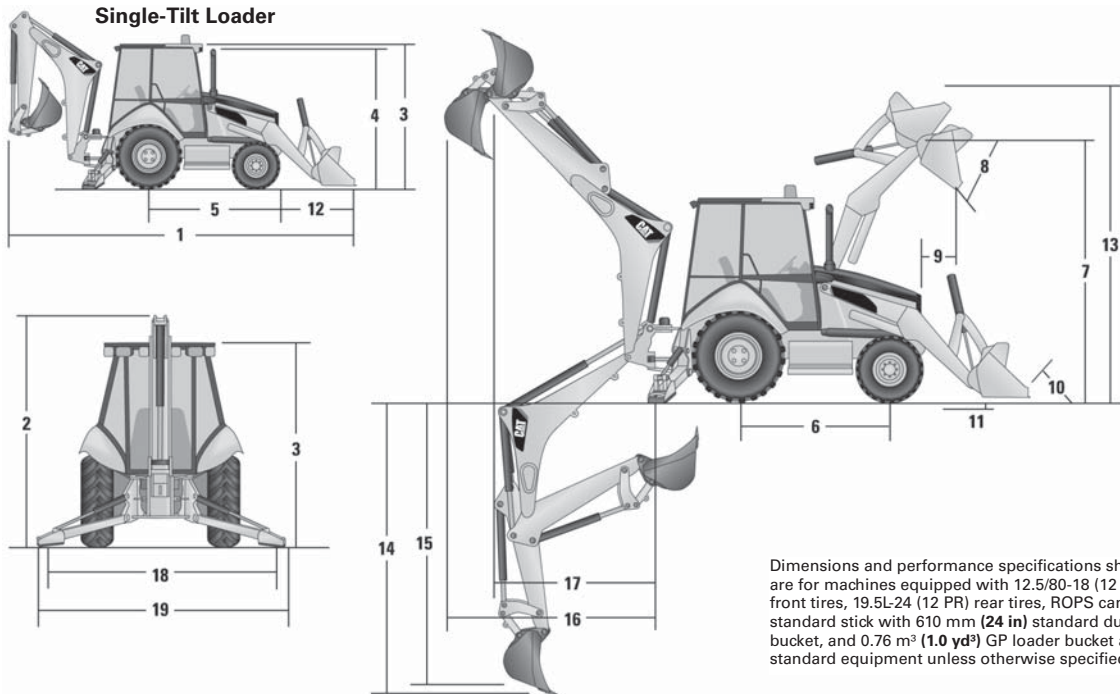

Dimensions and performance specifications shown are for machines equipped with 12.5/80-18 (12 PR) front tires, 19.5L-24 (12 PR) rear tires, ROPS canopy, standard stick with 610 mm (24 in) standard duty bucket, and 0.76 m³ (1.0 yd³) GP loader bucket and standard equipment unless otherwise specified.

LOADER BUCKET DIMENSIONS AND PERFORMANCE	Single-Tilt Loader							
	General Purpose 0.76 m ³ (1.0 yd ³)		General Purpose 0.96 m ³ (1.25 yd ³)		Multi Purpose 1.0 m ³ (1.31 yd ³)		Multi Purpose with Forks 1.0 m ³ (1.31 yd ³)	
Capacity (SAE) rated	0.76 m ³	1.0 yd³	0.96 m ³	1.25 yd³	1.0 m ³	1.31 yd³	1.0 m ³	1.31 yd³
Width	2262 mm	7'5"	2262 mm	7'5"	2279 mm	7'6"	2279 mm	7'6"
Lift capacity at maximum height	3062 kg	6751 lb	2964 kg	6535 lb	2771 kg	6108 lb	2656 kg	5855 lb
Lift breakout force	47.9 kN	10,772 lbf	45.3 kN	10,189 lbf	44.4 kN	9979 lbf	42.9 kN	9645 lbf
Tilt breakout force	54.6 kN	12,281 lbf	46.0 kN	10,339 lbf	52.7 kN	11,841 lbf	51.8 kN	11,636 lbf
7) Maximum hinge pin height	3474 mm	11'5"	3474 mm	11'5"	3474 mm	11'5"	3474 mm	11'5"
8) Dump angle at full height		44°		44°		44°		44°
Dump height at maximum angle	2824 mm	9'3"	2746 mm	9'0"	2798 mm	9'2"	2798 mm	9'2"
9) Dump reach at maximum angle	727 mm	2'5"	808 mm	2'8"	716 mm	2'4"	716 mm	2'4"
10) Maximum bucket rollback at ground level		37°		37°		38°		38°
11) Digging depth	83 mm	3"	83 mm	3"	110 mm	4"	110 mm	4"
Maximum grading angle		116°		112°		116°		116°
Width of dozer cutting edge		N/A		N/A	2262 mm	7'5"	2262 mm	7'5"
12) Grill to bucket cutting edge, carry position	1404 mm	4'7"	1487 mm	4'11"	1451 mm	4'9"	1451 mm	4'9"
13) Maximum operating height	4206 mm	13'10"	4355 mm	14'3"	4404 mm	14'5"	4878 mm	16'0"
Jaw opening maximum		N/A		N/A	790 mm	2'7"	790 mm	2'7"
Bucket jaw clamping force		N/A		N/A	50.6 kN	11,375 lbf	50.6 kN	11,375 lbf
Weight (does not include teeth or forks)	384 kg	847 lb	451 kg	994 lb	745 kg	1642 lb	915 kg	2017 lb

Single-Tilt Loader

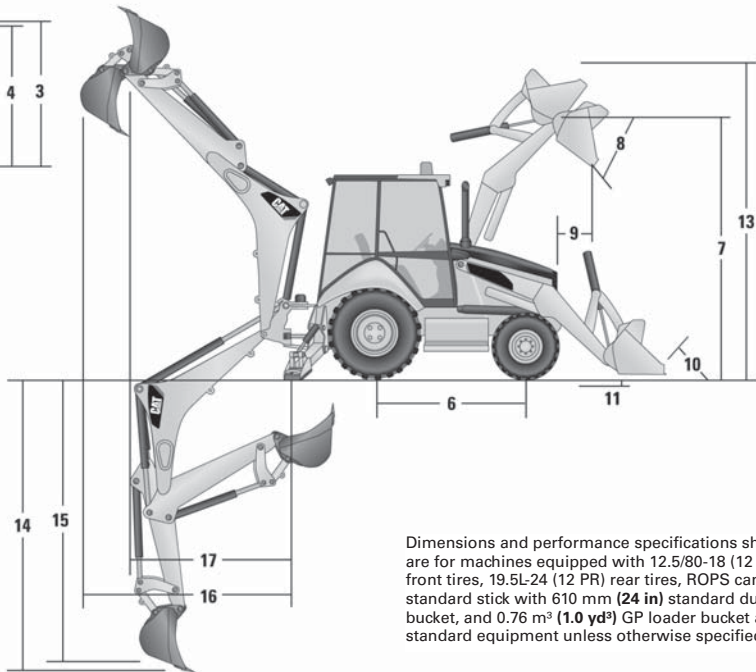
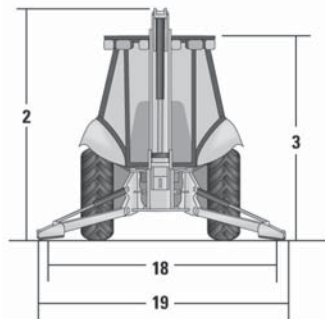
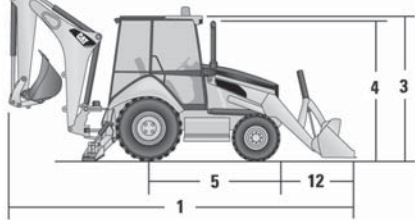

Dimensions and performance specifications shown are for machines equipped with 12.5/80-18 (12 PR) front tires, 19.5L-24 (12 PR) rear tires, ROPS canopy, standard stick with 610 mm (24 in) standard duty bucket, and 0.76 m³ (1.0 yd³) GP loader bucket and standard equipment unless otherwise specified.

BACKHOE DIMENSIONS AND PERFORMANCE	Standard Stick		Extendible Stick Retracted		Extendible Stick Extended	
	14) Digging depth, SAE (maximum)	4348 mm	14'3"	4389 mm	14'5"	5441 mm
15) Digging depth, 610 mm (2'0") flat bottom	4309 mm	14'2"	4350 mm	14'3"	5404 mm	17'9"
Reach from rear axle centerline at ground line	6702 mm	22'0"	6738 mm	22'1"	7742 mm	25'5"
16) Reach from swing pivot at ground line	5612 mm	18'5"	5648 mm	18'6"	6652 mm	21'10"
Maximum operating height	5525 mm	18'2"	5549 mm	18'2"	6286 mm	20'7"
Loading height	3643 mm	11'11"	3600 mm	11'10"	4170 mm	13'8"
17) Loading reach	1838 mm	6'0"	1925 mm	6'4"	2840 mm	9'4"
Swing arc		180°		180°		180°
Bucket rotation		205°		204°		204°
18) Stabilizer spread, operating position (center of pad)	3310 mm	10'10"	3310 mm	10'10"	3310 mm	10'10"
19) Stabilizer spread, operating position (outside edge of pad)	3770 mm	12'4"	3770 mm	12'4"	3770 mm	12'4"
Stabilizer spread, transport position	2322 mm	7'7"	2322 mm	7'7"	2322 mm	7'7"
Bucket dig force	59.1 kN	13,290 lbf	58.3 kN	13,103 lbf	58.3 kN	13,103 lbf
Stick dig force	32.4 kN	7276 lbf	32.4 kN	7286 lbf	23.8 kN	5346 lbf

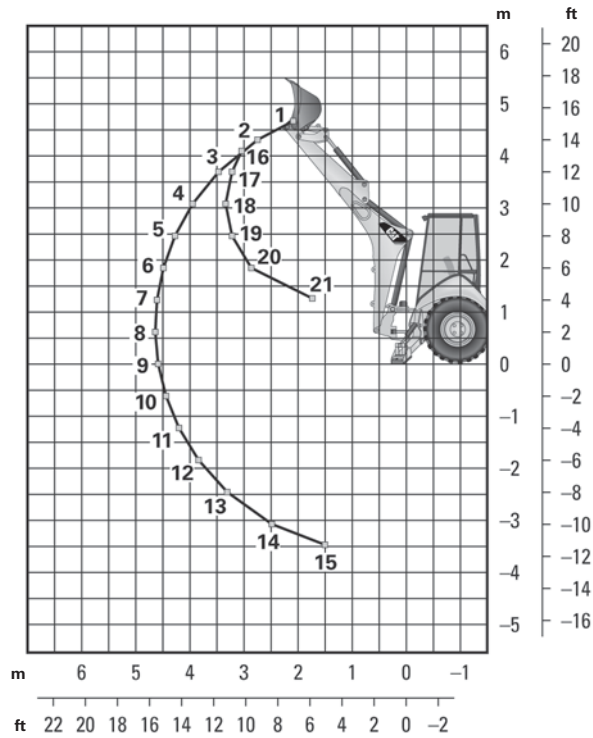

Standard Stick

Boom Lifting

1	1296 kg	2851 lb
2	1410 kg	3101 lb
3	1419 kg	3123 lb
4	1379 kg	3033 lb
5	1326 kg	2917 lb
6	1271 kg	2797 lb
7	1218 kg	2680 lb
8	1168 kg	2569 lb
9	1121 kg	2466 lb
10	1078 kg	2372 lb
11	1039 kg	2286 lb
12	1006 kg	2213 lb
13	981 kg	2157 lb
14	979 kg	2153 lb
15	1073 kg	2361 lb

Stick Lifting

16	1312 kg	2885 lb
17	1849 kg	4068 lb
18	2307 kg	5075 lb
19	2400 kg	5280 lb
20	2790 kg	6137 lb
21	5561 kg	12,234 lb

Lift Capacities are over-end values. Machine equipped with AWD, OROPS, 0.76 m³ (1.0 yd³) general purpose bucket, and 115 kg (255 lb) counterweight. Extendible stick includes 460 kg (1015 lb) counterweight.

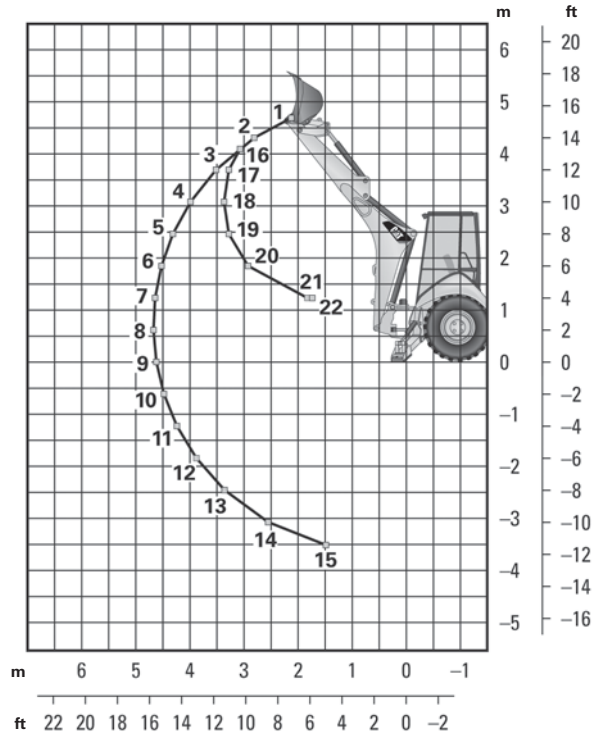

Extendible Stick Retracted

Boom Lifting

1	1117 kg	2457 lb
2	1214 kg	2670 lb
3	1212 kg	2665 lb
4	1166 kg	2566 lb
5	1111 kg	2444 lb
6	1054 kg	2319 lb
7	999 kg	2197 lb
8	946 kg	2082 lb
9	897 kg	1974 lb
10	852 kg	1873 lb
11	809 kg	1780 lb
12	771 kg	1696 lb
13	738 kg	1623 lb
14	718 kg	1580 lb
15	767 kg	1687 lb

Stick Lifting

16	1169 kg	2572 lb
17	1694 kg	3726 lb
18	2107 kg	4634 lb
19	2183 kg	4802 lb
20	2533 kg	5573 lb
21	4983 kg	10,963 lb
22	5330 kg	11,725 lb

Lift Capacities are over-end values. Machine equipped with AWD, OROPS, 0.76 m³ (1.0 yd³) general purpose bucket, and 115 kg (255 lb) counterweight. Extendible stick includes 460 kg (1015 lb) counterweight.

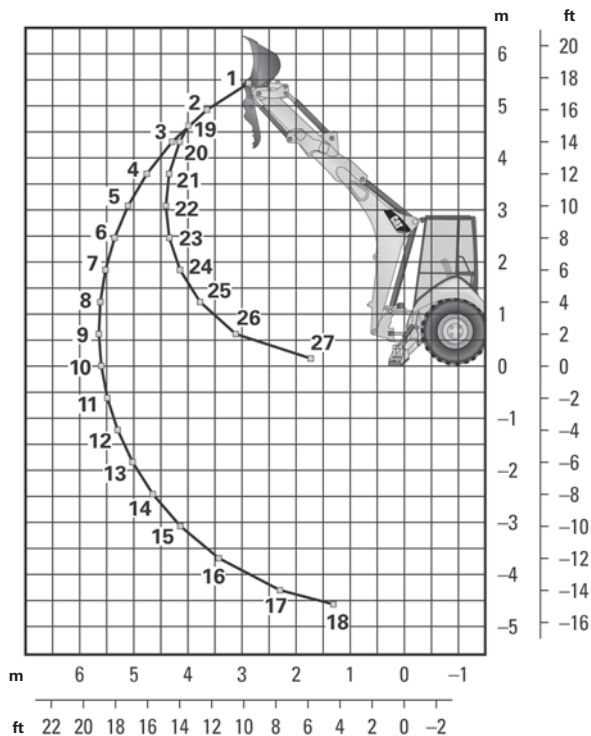

Extendible Stick Extended

Boom Lifting

1	617 kg	1357 lb
2	750 kg	1650 lb
3	797 kg	1752 lb
4	802 kg	1765 lb
5	791 kg	1741 lb
6	770 kg	1695 lb
7	750 kg	1649 lb
8	726 kg	1597 lb
9	702 kg	1544 lb
10	679 kg	1493 lb
11	657 kg	1445 lb
12	637 kg	1401 lb
13	620 kg	1363 lb
14	607 kg	1334 lb
15	601 kg	1322 lb
16	612 kg	1347 lb
17	699 kg	1537 lb
18	1030 kg	2267 lb

Stick Lifting

19	552 kg	1214 lb
20	735 kg	1617 lb
21	987 kg	2171 lb
22	1162 kg	2556 lb
23	1307 kg	2876 lb
24	1460 kg	3212 lb
25	1679 kg	3694 lb
26	2192 kg	4823 lb
27	5301 kg	11,662 lb

Lift Capacities are over-end values. Machine equipped with AWD, OROPS, 0.76 m³ (1.0 yd³) general purpose bucket, and 115 kg (255 lb) counterweight. Extendible stick includes 460 kg (1015 lb) counterweight.

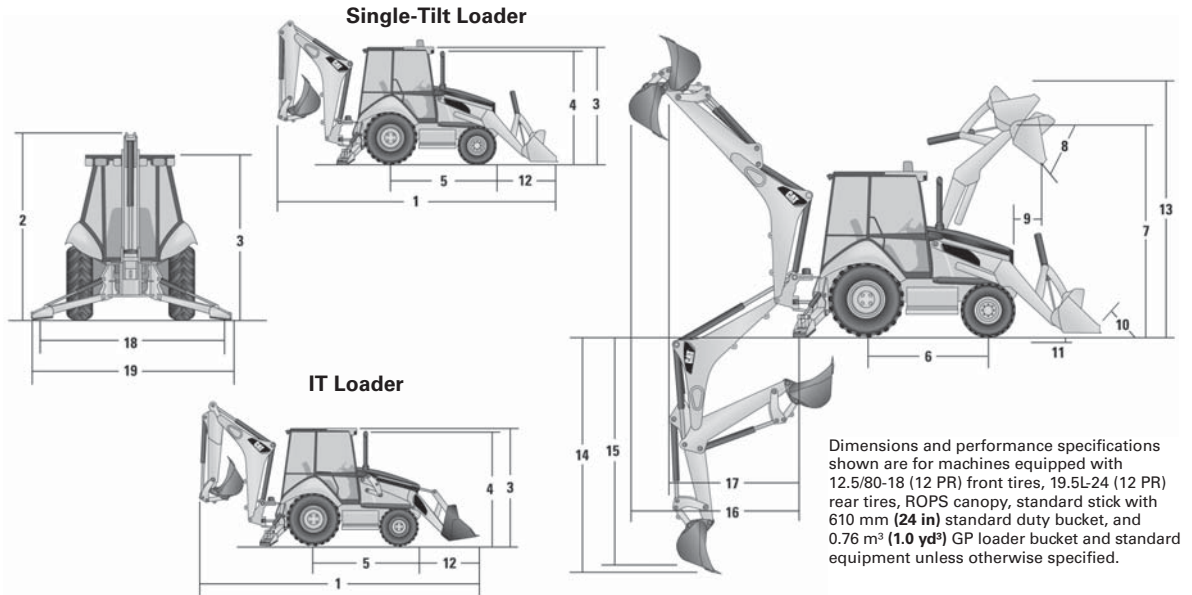

MACHINE DIMENSIONS	Single-Tilt Loader							
	General Purpose 0.96 m ³ (1.25 yd ³)		General Purpose 1.0 m ³ (1.31 yd ³)		General Purpose 1.07 m ³ (1.4 yd ³)		General Purpose 1.15 m ³ (1.5 yd ³)	
1) Overall transport length	7169 mm	23'6"	7136 mm	23'5"	7208 mm	23'8"	7208 mm	23'8"
Overall length	7141 mm	23'5"	7096 mm	23'3"	7161 mm	23'6"	7161 mm	23'6"
2) Overall transport height S-stick	3577 mm	11'9"	3577 mm	11'9"	3577 mm	11'9"	3577 mm	11'9"
Overall transport height E-stick	3631 mm	11'11"	3631 mm	11'11"	3631 mm	11'11"	3631 mm	11'11"
Overall width	2322 mm	7'7"	2322 mm	7'7"	2322 mm	7'7"	2322 mm	7'7"
3) Height to top of cab/canopy	2819 mm	9'3"	2819 mm	9'3"	2819 mm	9'3"	2819 mm	9'3"
4) Height to top of exhaust stack	2744 mm	9'0"	2744 mm	9'0"	2744 mm	9'0"	2744 mm	9'0"
Ground clearance (LH step)	294 mm	1'0"	294 mm	1'0"	294 mm	1'0"	294 mm	1'0"
Ground clearance (AWD guard)	294 mm	1'0"	294 mm	1'0"	294 mm	1'0"	294 mm	1'0"
Ground clearance (485 kg/ 1170 lb counterweight)	274 mm	11"	274 mm	11"	274 mm	11"	274 mm	11"
5) Rear axle centerline to front grill	2705 mm	8'10"	2705 mm	8'10"	2705 mm	8'10"	2705 mm	8'10"
Front wheel tread gauge	1895 mm	6'3"	1895 mm	6'3"	1895 mm	6'3"	1895 mm	6'3"
Rear wheel tread gauge	1714 mm	5'7"	1714 mm	5'7"	1714 mm	5'7"	1714 mm	5'7"
6) Wheelbase (2WD/AWD)	2200 mm	7'3"	2200 mm	7'3"	2200 mm	7'3"	2200 mm	7'3"

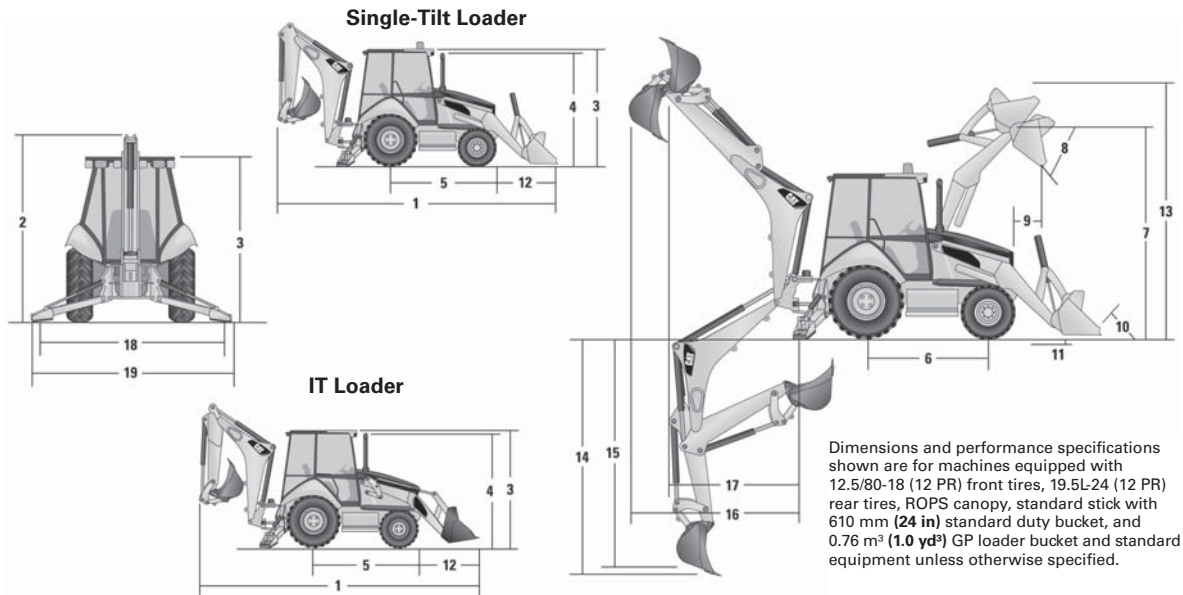

MACHINE DIMENSIONS	Single-Tilt Loader							
	Multi Purpose 1.0 m ³ (1.31 yd ³)		Multi Purpose 1.07 m ³ (1.4 yd ³)		Multi Purpose with Forks 1.0 m ³ (1.31 yd ³)		Multi Purpose with Forks 1.07 m ³ (1.4 yd ³)	
1) Overall transport length	7133 mm	23'5"	7133 mm	23'5"	7133 mm	23'5"	7133 mm	23'5"
Overall length	7059 mm	23'2"	7059 mm	23'2"	7059 mm	23'2"	7059 mm	23'2"
2) Overall transport height S-stick	3577 mm	11'9"	3577 mm	11'9"	3577 mm	11'9"	3577 mm	11'9"
Overall transport height E-stick	3631 mm	11'11"	3631 mm	11'11"	3631 mm	11'11"	3631 mm	11'11"
Overall width	2322 mm	7'7"	2322 mm	7'7"	2322 mm	7'7"	2322 mm	7'7"
3) Height to top of cab/canopy	2819 mm	9'3"	2819 mm	9'3"	2819 mm	9'3"	2819 mm	9'3"
4) Height to top of exhaust stack	2744 mm	9'0"	2744 mm	9'0"	2744 mm	9'0"	2744 mm	9'0"
Ground clearance (LH step)	294 mm	1'0"	294 mm	1'0"	294 mm	1'0"	294 mm	1'0"
Ground clearance (AWD guard)	294 mm	1'0"	294 mm	1'0"	294 mm	1'0"	294 mm	1'0"
Ground clearance (485 kg/ 1170 lb counterweight)	274 mm	11"	274 mm	11"	274 mm	11"	274 mm	11"
5) Rear axle centerline to front grill	2705 mm	8'10"	2705 mm	8'10"	2705 mm	8'10"	2705 mm	8'10"
Front wheel tread gauge	1895 mm	6'3"	1895 mm	6'3"	1895 mm	6'3"	1895 mm	6'3"
Rear wheel tread gauge	1714 mm	5'7"	1714 mm	5'7"	1714 mm	5'7"	1714 mm	5'7"
6) Wheelbase (2WD/AWD)	2200 mm	7'3"	2200 mm	7'3"	2200 mm	7'3"	2200 mm	7'3"

MACHINE DIMENSIONS	IT Loader with Quick Coupler					
	General Purpose 0.96 m ³ (1.25 yd ³)		General Purpose 1.0 m ³ (1.31 yd ³)		General Purpose 1.15 m ³ (1.5 yd ³)	
1) Overall transport length	7282 mm	23'11"	7250 mm	23'9"	7279 mm	23'11"
Overall length	7289 mm	23'11"	7244 mm	23'9"	7287 mm	23'11"
2) Overall transport height S-stick	3577 mm	11'9"	3577 mm	11'9"	3577 mm	11'9"
Overall transport height E-stick	3631 mm	11'11"	3631 mm	11'11"	3631 mm	11'11"
Overall width	2322 mm	7'7"	2322 mm	7'7"	2322 mm	7'7"
3) Height to top of cab/canopy	2819 mm	9'3"	2819 mm	9'3"	2819 mm	9'3"
4) Height to top of exhaust stack	2744 mm	9'0"	2744 mm	9'0"	2744 mm	9'0"
Ground clearance (LH step)	294 mm	1'0"	294 mm	1'0"	294 mm	1'0"
Ground clearance (AWD guard)	294 mm	1'0"	294 mm	1'0"	294 mm	1'0"
Ground clearance (485 kg/1170 lb counterweight)	274 mm	11"	274 mm	11"	274 mm	11"
5) Rear axle centerline to front grill	2705 mm	8'10"	2705 mm	8'10"	2705 mm	8'10"
Front wheel tread gauge	1895 mm	6'3"	1895 mm	6'3"	1895 mm	6'3"
Rear wheel tread gauge	1714 mm	5'7"	1714 mm	5'7"	1714 mm	5'7"
6) Wheelbase (2WD/AWD)	2200 mm	7'3"	2200 mm	7'3"	2200 mm	7'3"

MACHINE DIMENSIONS	IT Loader with Quick Coupler			
	Multi Purpose 1.0 m ³ (1.31 yd ³)		Multi Purpose 1.07 m ³ (1.4 yd ³)	
1) Overall transport length	7211 mm	23'8"	7211 mm	23'8"
Overall length	7197 mm	23'7"	7197 mm	23'7"
2) Overall transport height S-stick	3577 mm	11'9"	3577 mm	11'9"
Overall transport height E-stick	3631 mm	11'11"	3631 mm	11'11"
Overall width	2322 mm	7'7"	2322 mm	7'7"
3) Height to top of cab/canopy	2819 mm	9'3"	2819 mm	9'3"
4) Height to top of exhaust stack	2744 mm	9'0"	2744 mm	9'0"
Ground clearance (LH step)	294 mm	1'0"	294 mm	1'0"
Ground clearance (AWD guard)	294 mm	1'0"	294 mm	1'0"
Ground clearance (485 kg/1170 lb counterweight)	274 mm	11"	274 mm	11"
5) Rear axle centerline to front grill	2705 mm	8'10"	2705 mm	8'10"
Front wheel tread gauge	1895 mm	6'3"	1895 mm	6'3"
Rear wheel tread gauge	1714 mm	5'7"	1714 mm	5'7"
6) Wheelbase (2WD/AWD)	2200 mm	7'3"	2200 mm	7'3"

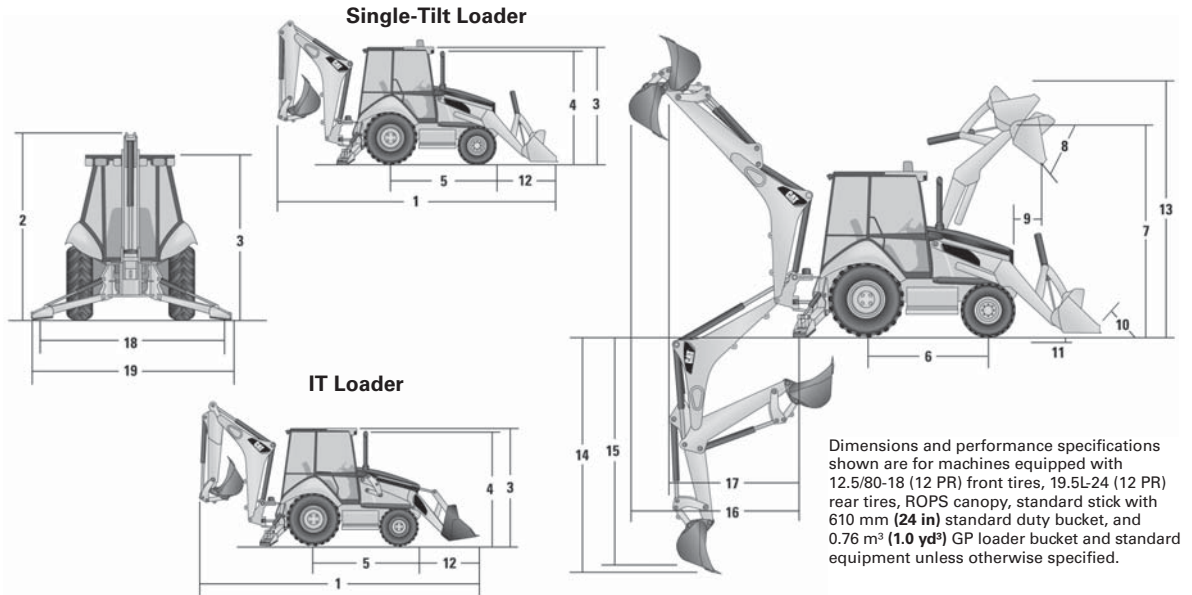

LOADER BUCKET DIMENSIONS AND PERFORMANCE	Single-Tilt Loader							
	General Purpose 0.96 m ³ (1.25 yd ³)		General Purpose 1.0 m ³ (1.31 yd ³)		General Purpose 1.07 m ³ (1.4 yd ³)		General Purpose 1.15 m ³ (1.5 yd ³)	
Capacity (SAE) rated	0.96 m ³	1.25 yd³	1.0 m ³	1.31 yd³	1.07 m ³	1.4 yd³	1.15 m ³	1.5 yd³
Width	2262 mm	89"	2406 mm	95"	2262 mm	89"	2406 mm	95"
Lift capacity at maximum height	3283 kg	7237 lb	3292 kg	7257 lb	3216 kg	7090 lb	3196 kg	7046 lb
Lift breakout force	49.8 kN	11,197 lbf	50.6 kN	11,367 lbf	49.3 kN	11,077 lbf	49.1 kN	11,037 lbf
Tilt breakout force	50.2 kN	11,283 lbf	53.4 kN	11,995 lbf	51.2 kN	11,518 lbf	51.1 kN	11,494 lbf
7) Maximum hinge pin height	3474 mm	11'5"	3474 mm	11'5"	3474 mm	11'5"	3474 mm	11'5"
8) Dump angle at full height		44°		44°		44°		44°
Dump height at maximum angle	2746 mm	9'0"	2777 mm	9'1"	2723 mm	8'11"	2723 mm	8'11"
9) Dump reach at maximum angle	808 mm	2'8"	775 mm	2'7"	773 mm	2'6"	773 mm	2'6"
10) Maximum bucket rollback at ground level		37°		37°		38°		38°
11) Digging depth	83 mm	3"	83 mm	3"	123 mm	5"	123 mm	5"
Maximum grading angle		112°		114°		113°		113°
Width of dozer cutting edge		N/A		N/A		N/A		N/A
12) Grill to bucket cutting edge, carry position	1487 mm	4'11"	1454 mm	4'10"	1525 mm	5'1"	1525 mm	5'1"
13) Maximum operating height	4355 mm	14'3"	4353 mm	13'9"	4395 mm	13'11"	4395 mm	13'11"
Jaw opening maximum		N/A		N/A		N/A		N/A
Bucket jaw clamping force		N/A		N/A		N/A		N/A
Weight (does not include teeth or forks)	451 kg	994 lb	462 kg	1019 lb	473 kg	1043 lb	493 kg	1087 lb

LOADER BUCKET DIMENSIONS AND PERFORMANCE	Single-Tilt Loader							
	Multi Purpose 1.0 m ³ (1.31 yd ³)		Multi Purpose 1.07 m ³ (1.4 yd ³)		Multi Purpose with Forks 1.0 m ³ (1.31 yd ³)		Multi Purpose with Forks 1.07 m ³ (1.4 yd ³)	
Capacity (SAE) rated	1.0 m ³	1.31 yd³	1.07 m ³	1.4 yd³	1.0 m ³	1.31 yd³	1.07 m ³	1.4 yd³
Width	2279 mm	90"	2425 mm	95"	2279 mm	90"	2425 mm	95"
Lift capacity at maximum height	3097 kg	6828 lb	3068 kg	6764 lb	2982 kg	6575 lb	2953 kg	6511 lb
Lift breakout force	49.0 kN	11,020 lbf	48.8 kN	10,964 lbf	47.5 kN	10,685 lbf	47.3 kN	10,629 lbf
Tilt breakout force	57.6 kN	12,938 lbf	57.4 kN	12,905 lbf	56.6 kN	12,733 lbf	56.5 kN	12,700 lbf
7) Maximum hinge pin height	3474 mm	11'5"	3474 mm	11'5"	3474 mm	11'5"	3474 mm	11'5"
8) Dump angle at full height		44°		44°		44°		44°
Dump height at maximum angle	2798 mm	9'2"	2798 mm	9'2"	2798 mm	9'2"	2798 mm	9'2"
9) Dump reach at maximum angle	716 mm	2'4"	716 mm	2'4"	716 mm	2'4"	716 mm	2'4"
10) Maximum bucket rollback at ground level		38°		38°		38°		38°
11) Digging depth	110 mm	4"	110 mm	4"	110 mm	4"	110 mm	4"
Maximum grading angle		116°		116°		116°		116°
Width of dozer cutting edge	2262 mm	7'5"	2406 mm	7'11"	2262 mm	7'5"	2406 mm	7'11"
12) Grill to bucket cutting edge, carry position	1451 mm	4'9"	1451 mm	4'9"	1451 mm	4'9"	1451 mm	4'9"
13) Maximum operating height	4404 mm	14'5"	4404 mm	14'5"	4878 mm	16'0"	4878 mm	16'0"
Jaw opening maximum	790 mm	2'7"	790 mm	2'7"	790 mm	2'7"	790 mm	2'7"
Bucket jaw clamping force	55.7 kN	12,521 lbf	55.7 kN	12,521 lbf	55.7 kN	12,521 lbf	55.7 kN	12,521 lbf
Weight (does not include teeth or forks)	745 kg	1642 lb	774 kg	1706 lb	915 kg	2017 lb	936 kg	2064 lb

LOADER BUCKET DIMENSIONS AND PERFORMANCE	IT Loader with Quick Coupler					
	General Purpose 0.96 m ³ (1.25 yd ³)		General Purpose 1.0 m ³ (1.31 yd ³)		General Purpose 1.15 m ³ (1.5 yd ³)	
Capacity (SAE) rated	0.96 m ³	1.25 yd³	1.0 m ³	1.31 yd³	1.15 m ³	1.5 yd³
Width	2262 mm	89"	2406 mm	95"	2406 mm	95"
Lift capacity at maximum height	3716 kg	8193 lb	3707 kg	8173 lb	3682 kg	8117 lb
Lift breakout force	51.1 kN	11,484 lbf	51.5 kN	11,575 lbf	50.8 kN	11,415 lbf
Tilt breakout force	46.3 kN	10,411 lbf	48.9 kN	10,999 lbf	46.1 kN	10,371 lbf
7) Maximum hinge pin height	3490 mm	11'5"	3490 mm	11'5"	3490 mm	11'5"
8) Dump angle at full height		44°		44°		44°
Dump height at maximum angle	2679 mm	8'9"	2710 mm	8'11"	2680 mm	8'10"
9) Dump reach at maximum angle	869 mm	2'10"	836 mm	2'9"	868 mm	2'10"
10) Maximum bucket rollback at ground level		40°		40°		40°
11) Digging depth	105 mm	4"	105 mm	4"	105 mm	4"
Maximum grading angle		110°		111°		110°
Width of dozer cutting edge		N/A		N/A		N/A
12) Grill to bucket cutting edge, carry position	1600 mm	5'3"	1568 mm	5'2"	1597 mm	5'3"
13) Maximum operating height	4407 mm	14'6"	4407 mm	14'6"	4477 mm	14'8"
Jaw opening maximum		N/A		N/A		N/A
Bucket jaw clamping force		N/A		N/A		N/A
Weight (does not include teeth or forks)	447 kg	985 lb	457 kg	1008 lb	481 kg	1060 lb

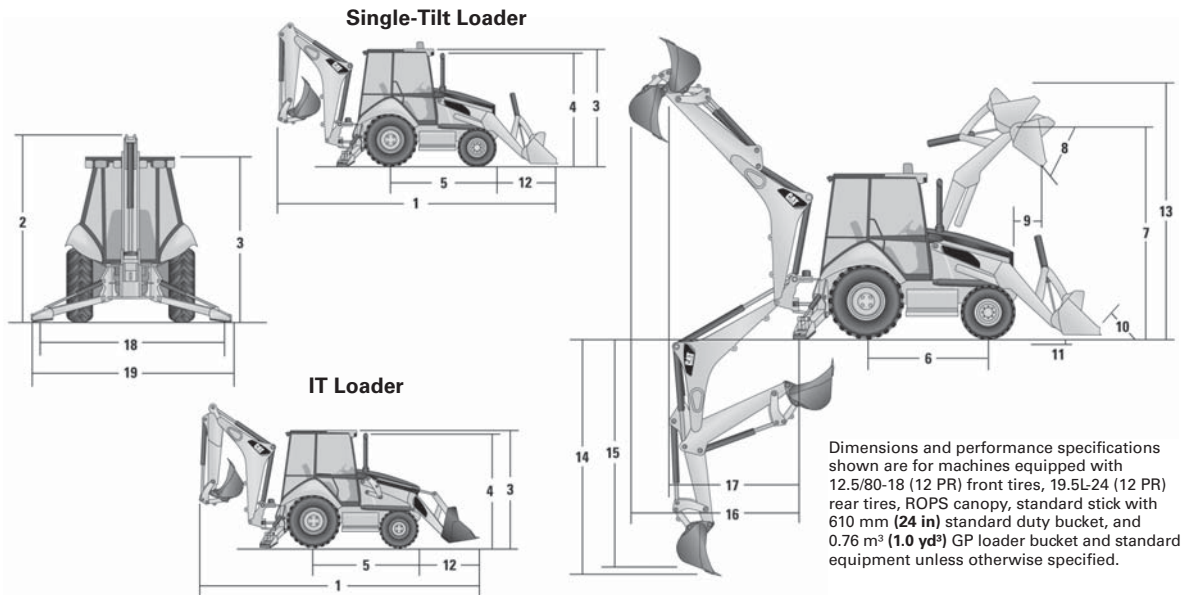

LOADER BUCKET DIMENSIONS AND PERFORMANCE	IT Loader with Quick Coupler			
	Multi Purpose 1.0 m ³ (1.31 yd ³)		Multi Purpose 1.07 m ³ (1.4 yd ³)	
Capacity (SAE) rated	1.0 m ³	1.31 yd³	1.07 m ³	1.4 yd³
Width	2279 mm	90"	2425 mm	95"
Lift capacity at maximum height	3448 kg	7601 lb	3419 kg	7537 lb
Lift breakout force	49.7 kN	11,168 lbf	49.4 kN	11,108 lbf
Tilt breakout force	50.4 kN	11,325 lbf	50.2 kN	11,288 lbf
7) Maximum hinge pin height	3490 mm	11'5"	3490 mm	11'5"
8) Dump angle at full height		44°		44°
Dump height at maximum angle	2745 mm	9'0"	2745 mm	9'0"
9) Dump reach at maximum angle	814 mm	2'8"	814 mm	2'8"
10) Maximum bucket rollback at ground level		39°		39°
11) Digging depth	95 mm	4"	95 mm	4"
Maximum grading angle		112°		112°
Width of dozer cutting edge	2262 mm	7'5"	2406 mm	7'11"
12) Grill to bucket cutting edge, carry position	1529 mm	5'0"	1529 mm	5'0"
13) Maximum operating height	4480 mm	14'8"	4480 mm	14'8"
Jaw opening maximum	790 mm	2'7"	790 mm	2'7"
Bucket jaw clamping force	55.7 kN	12,521 lbf	55.7 kN	12,521 lbf
Weight (does not include teeth or forks)	724 kg	1596 lb	753 kg	1660 lb

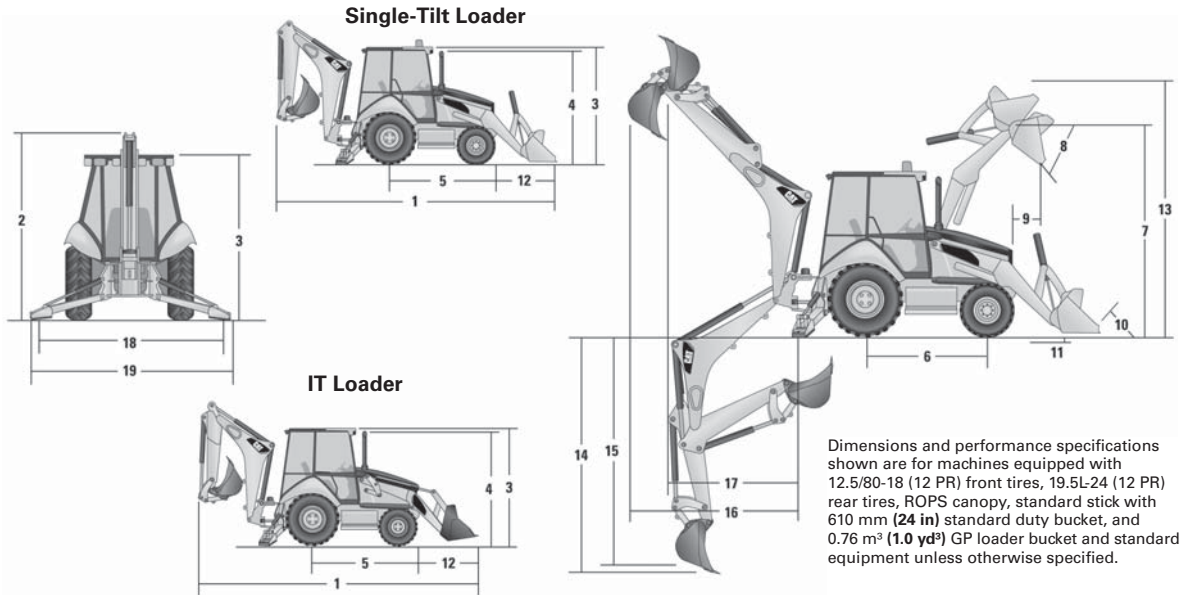

Dimensions and performance specifications shown are for machines equipped with 12.5/80-18 (12 PR) front tires, 19.5L-24 (12 PR) rear tires, ROPS canopy, standard stick with 610 mm (24 in) standard duty bucket, and 0.76 m³ (1.0 yd³) GP loader bucket and standard equipment unless otherwise specified.

BACKHOE DIMENSIONS AND PERFORMANCE	Standard Stick		Extendible Stick Retracted		Extendible Stick Extended	
	14) Digging depth, SAE (maximum)	4350 mm	14'3"	4390 mm	14'5"	5442 mm
15) Digging depth, 610 mm (2'0") flat bottom	4311 mm	14'2"	4351 mm	14'3"	5405 mm	17'9"
Reach from rear axle centerline at ground line	6702 mm	22'0"	6737 mm	22'1"	7742 mm	25'5"
16) Reach from swing pivot at ground line	5612 mm	18'5"	5647 mm	18'6"	6652 mm	21'10"
Maximum operating height	5522 mm	18'1"	5546 mm	18'2"	6282 mm	20'7"
Loading height	3642 mm	11'11"	3599 mm	11'10"	4169 mm	13'8"
17) Loading reach	1842 mm	6'1"	1929 mm	6'4"	2844 mm	9'4"
Swing arc		180°		180°		180°
Bucket rotation		205°		204°		204°
18) Stabilizer spread, operating position (center of pad)	3310 mm	10'10"	3310 mm	10'10"	3310 mm	10'10"
19) Stabilizer spread, operating position (outside edge of pad)	3770 mm	12'4"	3770 mm	12'4"	3770 mm	12'4"
Stabilizer spread, transport position	2322 mm	7'7"	2322 mm	7'7"	2322 mm	7'7"
Bucket dig force	64.2 kN	14,431 lbf	63.3 kN	14,228 lbf	63.3 kN	14,228 lbf
Stick dig force	43.5 kN	9781 lbf	43.4 kN	9757 lbf	31.7 kN	7122 lbf

DIMENSIONS WITH FORKS/ MATERIAL-HANDLING ARM		Cat 420F2 IT Operating Specifications with Forks					
Fork Tine Length		1070 mm (3'6")		1220 mm (4'0")		1370 mm (4'6")	
Operating load (SAE J1197)		2340 kg	5159 lb	2263 kg	4990 lb	2191 kg	4829 lb
SAE load center		535 mm	1'9"	610 mm	2'0"	685 mm	2'3"
Operating load (CEN 474-4)		2772 kg	6111 lb	2749 kg	6062 lb	2726 kg	6009 lb
CEN load center		500 mm	1'8"	500 mm	1'8"	500 mm	1'8"
Overall length (A) (forks on ground)		7681 mm	25'2"	7832 mm	25'8"	7980 mm	26'2"

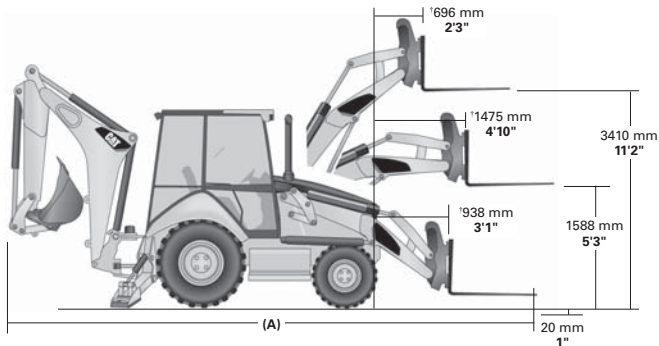

Operating load is hydraulic and tip limited.

†Measured from nose of machine.

DIMENSIONS WITH FORKS/ MATERIAL-HANDLING ARM		Cat 420F2 IT Operating Specifications with Material Handling Arm					
Material-Handling Arm Position		Retracted		Mid-Position		Extended	
Operating load (SAE J1197 and CEN 474-4)		1058 kg	2333 lb	674 kg	1487 lb	495 kg	1092 lb
Overall length, maximum		8867 mm	29'1"	9864 mm	32'4"	10 864 mm	35'8"

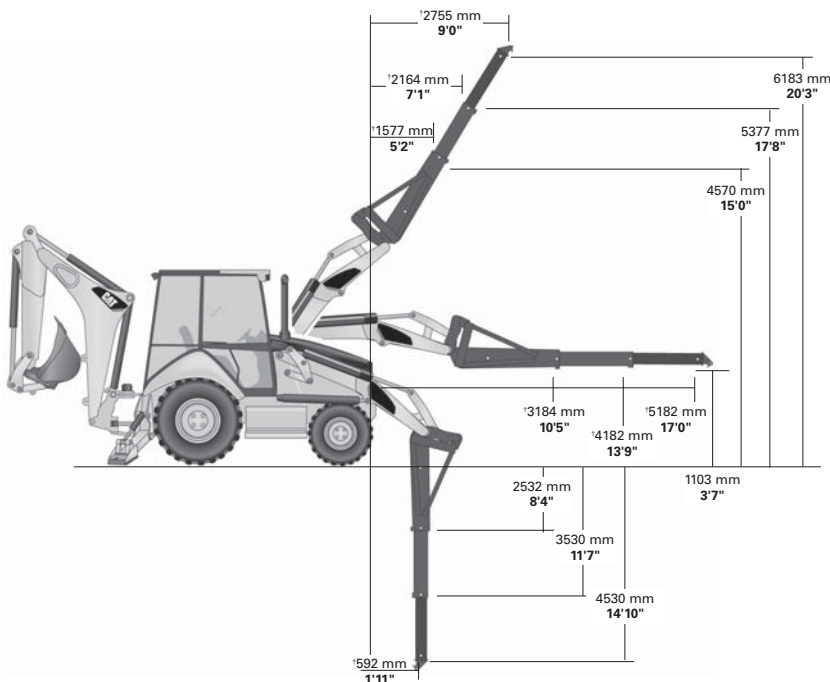

Operating load is hydraulic and tip limited.

Dimensions and performance specifications shown are for 4WD machines equipped with 12.5/80-18 I-3 front tires, 19.5L-24 R-4 ATU rear tires, ROPS canopy, standard stick with 610 mm (24 in) standard duty bucket, and 0.96 m³ (1.25 yd³) loader bucket and standard equipment unless otherwise specified.

†Measured from nose of machine.

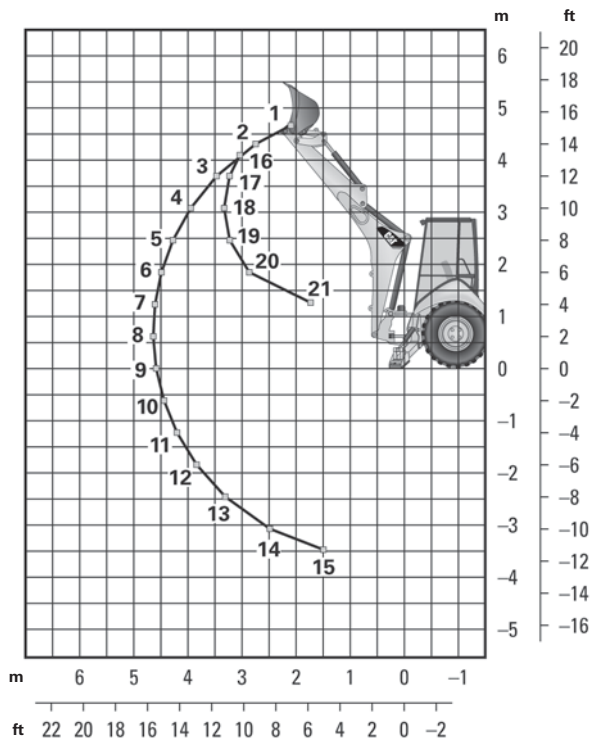

Standard Stick

Boom Lifting

1	1621 kg	3573 lb
2	1766 kg	3894 lb
3	1785 kg	3936 lb
4	1740 kg	3835 lb
5	1678 kg	3700 lb
6	1614 kg	3558 lb
7	1551 kg	3420 lb
8	1492 kg	3289 lb
9	1437 kg	3168 lb
10	1387 kg	3058 lb
11	1342 kg	2959 lb
12	1304 kg	2875 lb
13	1278 kg	2817 lb
14	1284 kg	2831 lb
15	1426 kg	3145 lb

Stick Lifting

16	1831 kg	4037 lb
17	2557 kg	5638 lb
18	2608 kg	5749 lb
19	2704 kg	5961 lb
20	3140 kg	6921 lb
21	6232 kg	13,739 lb

Lift Capacities are over-end values. Machine equipped with ST linkage, AWD, OROPS, 0.96 m³ (1.25 yd³) general purpose bucket, and 240 kg (530 lb) counterweight. Extendible stick includes 460 kg (1015 lb) counterweight.

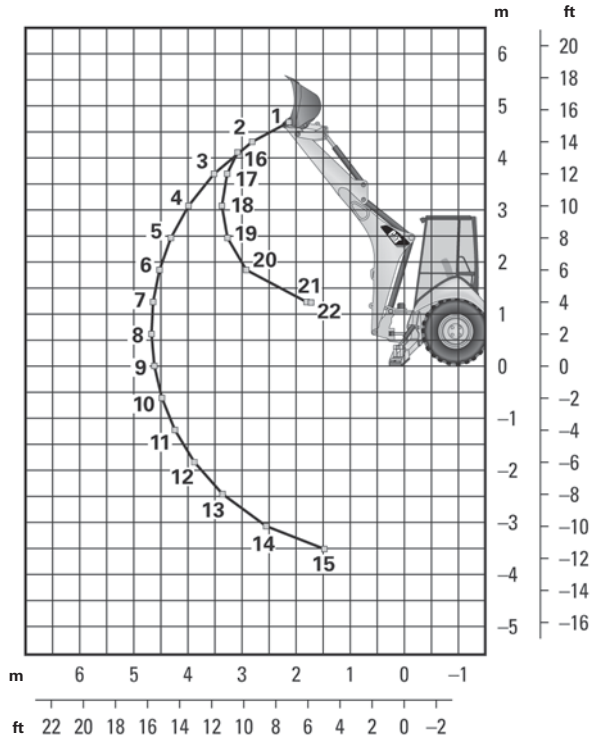

Extendible Stick Retracted

Boom Lifting

1	1439 kg	3173 lb
2	1573 kg	3468 lb
3	1582 kg	3487 lb
4	1533 kg	3380 lb
5	1470 kg	3241 lb
6	1405 kg	3097 lb
7	1341 kg	2957 lb
8	1281 kg	2823 lb
9	1224 kg	2699 lb
10	1172 kg	2584 lb
11	1124 kg	2479 lb
12	1083 kg	2387 lb
13	1050 kg	2314 lb
14	1040 kg	2293 lb
15	1149 kg	2534 lb

Stick Lifting

16	1677 kg	3697 lb
17	2387 kg	5262 lb
18	2404 kg	5301 lb
19	2492 kg	5493 lb
20	2886 kg	6362 lb
21	5629 kg	12,409 lb
22	6024 kg	13,281 lb

Lift Capacities are over-end values. Machine equipped with ST linkage, AWD, OROPS, 0.96 m³ (1.25 yd³) general purpose bucket, and 240 kg (530 lb) counterweight. Extendible stick includes 460 kg (1015 lb) counterweight.

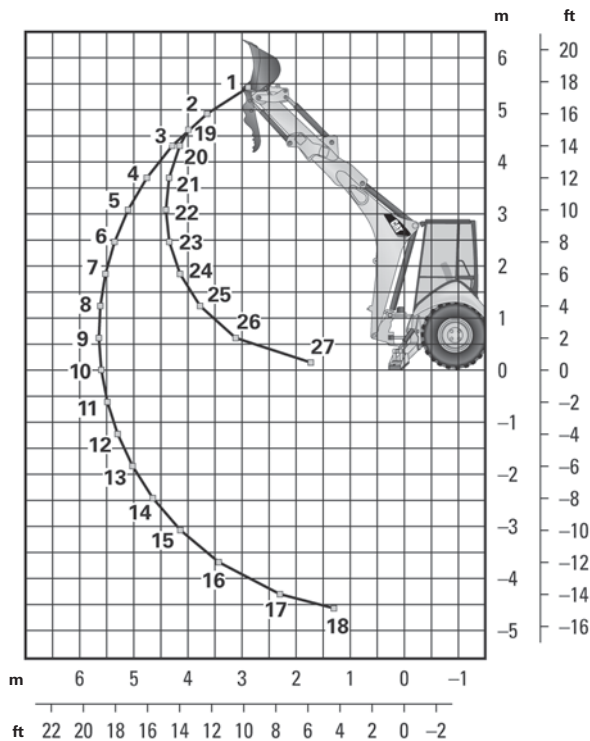

Extendible Stick Extended

Boom Lifting

1	838 kg	1849 lb
2	1010 kg	2226 lb
3	1073 kg	2366 lb
4	1085 kg	2392 lb
5	1070 kg	2358 lb
6	1041 kg	2296 lb
7	1030 kg	2271 lb
8	1003 kg	2212 lb
9	976 kg	2153 lb
10	950 kg	2095 lb
11	926 kg	2042 lb
12	905 kg	1994 lb
13	887 kg	1955 lb
14	875 kg	1928 lb
15	873 kg	1924 lb
16	895 kg	1973 lb
17	1023 kg	2255 lb
18	1502 kg	3311 lb

Stick Lifting

19	868 kg	1914 lb
20	1116 kg	2461 lb
21	1457 kg	3212 lb
22	1644 kg	3624 lb
23	1671 kg	3684 lb
24	1777 kg	3918 lb
25	2015 kg	4442 lb
26	2614 kg	5762 lb
27	5992 kg	13,209 lb

Lift Capacities are over-end values. Machine equipped with ST linkage, AWD, OROPS, 0.96 m³ (1.25 yd³) general purpose bucket, and 240 kg (530 lb) counterweight. Extendible stick includes 460 kg (1015 lb) counterweight.

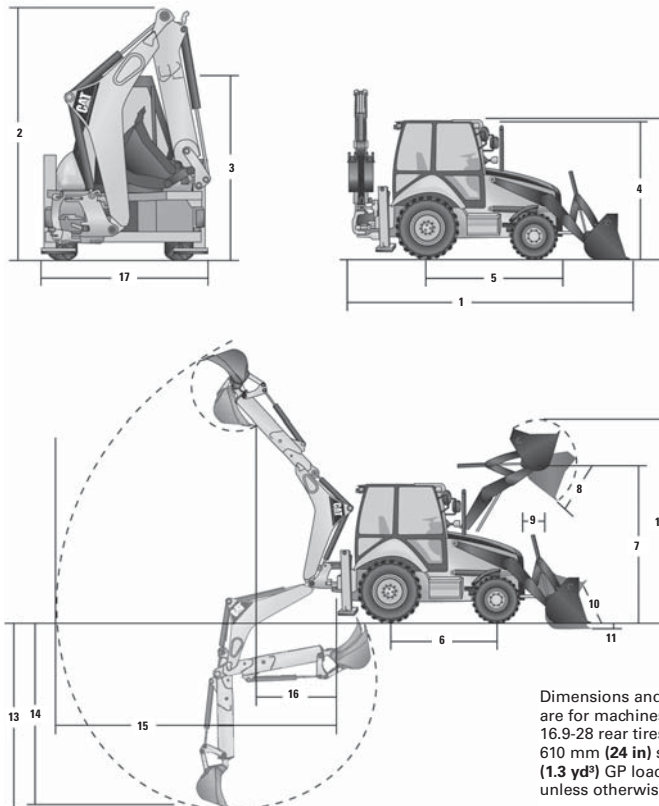

Dimensions and performance specifications shown are for machines equipped with 11L-16 front tires, 16.9-28 rear tires, ROPS canopy, standard stick with 610 mm (24 in) standard duty bucket, and 1.0 m³ (1.3 yd³) GP loader bucket and standard equipment unless otherwise specified.

MACHINE DIMENSIONS	General Purpose 1.0 m ³ (1.31 yd ³)		Multi Purpose 1.03 m ³ (1.35 yd ³)		Multi Purpose with Forks 1.03 m ³ (1.35 yd ³)	
	1) Overall length (loader on ground) Overall transport length	7333 mm 5772 mm	24'1" 18'11"	7327 mm 5728 mm	24'0" 18'10"	7327 mm 5728 mm
2) Overall transport height S-Stick Overall transport height E-Stick Overall width	3810 mm 3799 mm 2280 mm	12'6" 12'6" 7'6"	3810 mm 3799 mm 2280 mm	12'6" 12'6" 7'6"	3810 mm 3799 mm 2280 mm	12'6" 12'6" 7'6"
3) Height to top of cab/canopy	2829 mm	9'3"	2829 mm	9'3"	2829 mm	9'3"
4) Height to top of exhaust stack Height to loader hinge pin (transport) Ground clearance (stabilizer feet) Ground clearance (LH step) Ground clearance (AWD guard) Ground clearance (485 kg/1170 lb counterweight)	2681 mm 349 mm 347 mm 276 mm 263 mm 212 mm	8'10" 1'2" 1'2" 11" 10" 8"	2681 mm 316 mm 347 mm 276 mm 263 mm 212 mm	8'10" 1'0" 1'2" 11" 10" 8"	2681 mm 316 mm 347 mm 276 mm 263 mm 212 mm	8'10" 1'0" 1'2" 11" 10" 8"
5) Rear axle centerline to front grill Front wheel tread gauge Rear wheel tread gauge	2705 mm 1895 mm 1714 mm	8'10" 6'3" 5'7"	2705 mm 1895 mm 1714 mm	8'10" 6'3" 5'7"	2705 mm 1895 mm 1714 mm	8'10" 6'3" 5'7"
6) Wheelbase (AWD)	2200 mm	7'3"	2200 mm	7'3"	2200 mm	7'3"

LOADER BUCKET DIMENSIONS AND PERFORMANCE	General Purpose 1.0 m ³ (1.31 yd ³)		Multi Purpose 1.03 m ³ (1.35 yd ³)		Multi Purpose with Forks 1.03 m ³ (1.35 yd ³)	
	Capacity (SAE) rated	1.0 m ³	1.31 yd³	1.03 m ³	1.34 yd³	1.03 m ³
Width	2406 mm	95"	2406 mm	95"	2406 mm	95"
Lift capacity at maximum height	2823 kg	6223 lb	2640 kg	5821 lb	2518 kg	5552 lb
Lift breakout force	46.2 kN	10,375 lbf	44.9 kN	10,085 lbf	43.3 kN	9742 lbf
Tilt breakout force	49.0 kN	11,017 lbf	54.2 kN	12,183 lbf	53.3 kN	11,978 lbf
7) Maximum hinge pin height	3395 mm	11'2"	3395 mm	11'2"	3395 mm	11'2"
8) Dump angle at full height		46°		46°		46°
Dump height at maximum angle	2686 mm	8'10"	2711 mm	8'11"	2711 mm	8'11"
9) Dump reach at maximum angle	783 mm	2'7"	711 mm	2'4"	711 mm	2'4"
10) Maximum bucket rollback at ground level		37°		38°		38°
11) Digging depth	168 mm	7"	201 mm	8"	201 mm	8"
Maximum grading angle		113°		115°		115°
Width of dozer cutting edge		N/A	2406 mm	7'11"	2406 mm	7'11"
Grill to bucket cutting edge, carry position	1477 mm	4'10"	1438 mm	4'9"	1438 mm	4'9"
12) Maximum operating height	4293 mm	14'1"	4324 mm	14'2"	4324 mm	14'2"
Jaw opening maximum		N/A	790 mm	2'7"	790 mm	2'7"
Bucket jaw clamping force		N/A	62.2 kN	13,988 lbf	62.2 kN	13,988 lbf
Weight (does not include teeth or forks)	441 kg	973 lb	680 kg	1499 lb	851 kg	1876 lb

BACKHOE DIMENSIONS AND PERFORMANCE	Standard Stick		Extendible Stick Retracted		Extendible Stick Extended	
	13) Digging depth, manufacturers maximum	4843 mm	15'11"	4848 mm	15'11"	5765 mm
14) Digging depth, 610 mm (2'0") flat bottom	4199 mm	13'9"	4203 mm	13'9"	5202 mm	17'1"
15) Reach from swing pivot at ground line	5645 mm	18'6"	5650 mm	18'6"	6576 mm	21'7"
Loading height	4063 mm	13'4"	4071 mm	13'4"	4691 mm	15'5"
16) Loading reach	1613 mm	5'4"	1561 mm	5'1"	2408 mm	7'11"
Swing arc		180°		180°		180°
Bucket rotation		205°		205°		205°
17) Stabilizer width	2240 mm	7'4"	2240 mm	7'4"	2240 mm	7'4"
Bucket dig force	58.4 kN	13,137 lbf	58.4 kN	13,131 lbf	58.4 kN	13,131 lbf
Stick dig force	33.4 kN	7514 lbf	34.1 kN	7674 lbf	25.0 kN	5625 lbf
Total side shift travel	1096 mm	3'7"	1096 mm	3'7"	1096 mm	3'7"

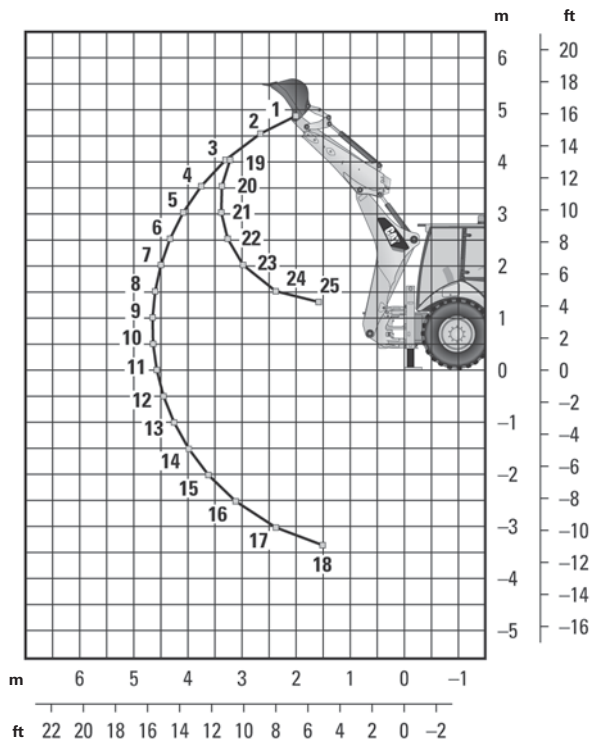

Standard Stick

Boom Lifting

1	1275 kg	2806 lb
2	1390 kg	3058 lb
3	1409 kg	3100 lb
4	1386 kg	3048 lb
5	1349 kg	2969 lb
6	1309 kg	2881 lb
7	1269 kg	2792 lb
8	1229 kg	2705 lb
9	1192 kg	2622 lb
10	1156 kg	2543 lb
11	1122 kg	2469 lb
12	1091 kg	2400 lb
13	1062 kg	2336 lb
14	1036 kg	2279 lb
15	1014 kg	2230 lb
16	999 kg	2197 lb
17	1003 kg	2206 lb
18	1077 kg	2370 lb

Stick Lifting

19	1989 kg	4375 lb
20	2186 kg	4808 lb
21	2171 kg	4776 lb
22	2265 kg	4983 lb
23	2532 kg	5570 lb
24	3369 kg	7413 lb
25	5150 kg	11,330 lb

Lift Capacities are over-end values. Machine equipped with 2WD, OROPS, 1.0 m³ (1.3 yd³) general purpose bucket, and 240 kg (530 lb) counterweight.

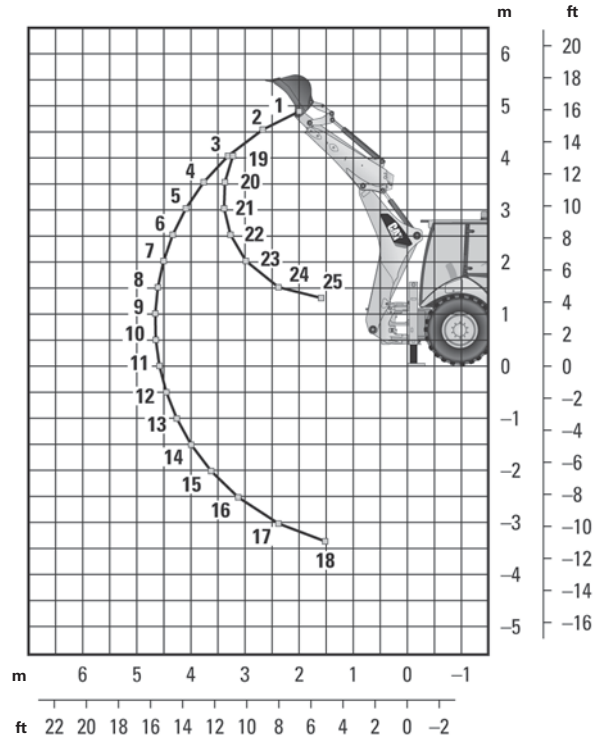

Extendible Stick Retracted

Boom Lifting

1	1196 kg	2630 lb
2	1282 kg	2820 lb
3	1282 kg	2821 lb
4	1249 kg	2748 lb
5	1206 kg	2653 lb
6	1161 kg	2554 lb
7	1116 kg	2455 lb
8	1073 kg	2360 lb
9	1031 kg	2269 lb
10	992 kg	2182 lb
11	954 kg	2100 lb
12	919 kg	2022 lb
13	886 kg	1949 lb
14	855 kg	1880 lb
15	826 kg	1816 lb
16	800 kg	1759 lb
17	781 kg	1718 lb
18	795 kg	1749 lb

Stick Lifting

19	1931 kg	4249 lb
20	2059 kg	4530 lb
21	2042 kg	4492 lb
22	2130 kg	4687 lb
23	2387 kg	5251 lb
24	3195 kg	7029 lb
25	4929 kg	10,843 lb

Lift Capacities are over-end values. Machine equipped with 2WD, OROPS, 1.0 m³ (1.3 yd³) general purpose bucket, and 240 kg (530 lb) counterweight.

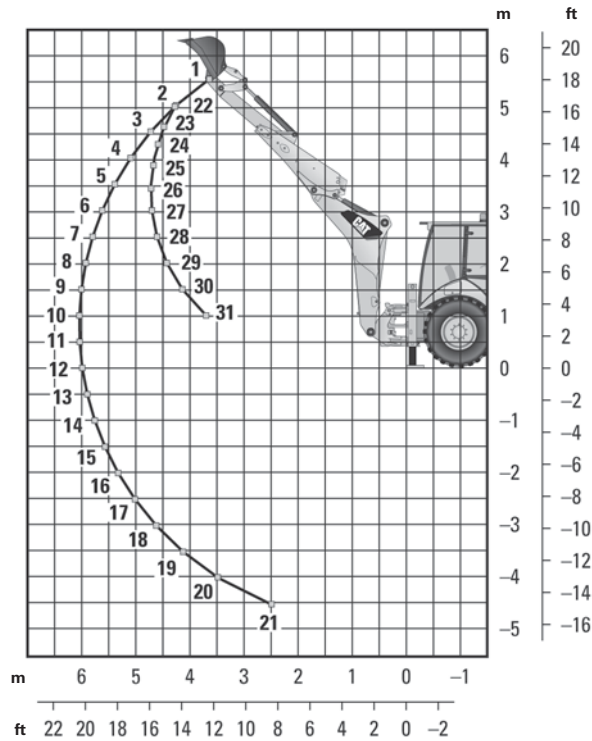

Extendible Stick Extended

Boom Lifting

1	683 kg	1503 lb
2	819 kg	1801 lb
3	872 kg	1919 lb
4	890 kg	1959 lb
5	892 kg	1962 lb
6	884 kg	1946 lb
7	872 kg	1919 lb
8	857 kg	1886 lb
9	841 kg	1850 lb
10	824 kg	1814 lb
11	808 kg	1777 lb
12	792 kg	1742 lb
13	776 kg	1708 lb
14	762 kg	1677 lb
15	750 kg	1650 lb
16	741 kg	1629 lb
17	735 kg	1616 lb
18	736 kg	1619 lb
19	752 kg	1654 lb
20	822 kg	1808 lb
21	1259 kg	2769 lb

Stick Lifting

22	1003 kg	2207 lb
23	1211 kg	2665 lb
24	1373 kg	3021 lb
25	1450 kg	3189 lb
26	1479 kg	3254 lb
27	1553 kg	3416 lb
28	1694 kg	3727 lb
29	1971 kg	4336 lb
30	2724 kg	5993 lb
31	5505 kg	12,112 lb

Lift Capacities are over-end values. Machine equipped with 2WD, OROPS, 1.0 m³ (1.3 yd³) general purpose bucket, and 240 kg (530 lb) counterweight.

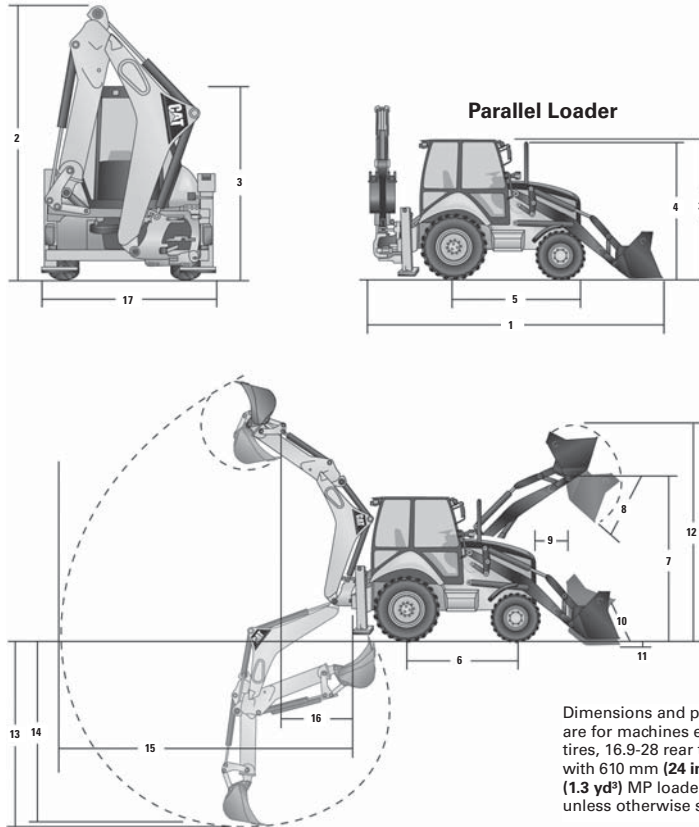

Dimensions and performance specifications shown are for machines equipped with 12.5/80-18 front tires, 16.9-28 rear tires, standard cab, standard stick with 610 mm (24 in) standard duty bucket, and 1.0 m³ (1.3 yd³) MP loader bucket and standard equipment unless otherwise specified.

MACHINE DIMENSIONS	Standard Frame					
	General Purpose 1.0 m ³ (1.31 yd ³)		Multi Purpose 1.03 m ³ (1.35 yd ³)		Multi Purpose with Forks 1.03 m ³ (1.35 yd ³)	
1) Overall length (loader on ground)	7398 mm	24'3"	7353 mm	24'1"	7353 mm	24'1"
Overall transport length	5750 mm	18'10"	5704 mm	18'9"	5704 mm	18'9"
2) Overall transport height S-Stick	3779 mm	12'5"	3791 mm	12'5"	3791 mm	12'5"
Overall transport height E-Stick	3771 mm	12'4"	3771 mm	12'4"	3771 mm	12'4"
Overall width (Standard)	2352 mm	7'9"	2352 mm	7'9"	2352 mm	7'9"
Overall width (Narrow)	2352 mm	7'9"	2352 mm	7'9"	2352 mm	7'9"
3) Height to top of cab/canopy	2897 mm	9'6"	2897 mm	9'6"	2897 mm	9'6"
4) Height to top of exhaust stack	2744 mm	9'0"	2744 mm	9'0"	2744 mm	9'0"
Height to loader hinge pin (transport)	361 mm	1'2"	318 mm	1'1"	318 mm	1'1"
Ground clearance (stabilizer feet)	336 mm	1'1"	336 mm	1'1"	336 mm	1'1"
Ground clearance (LH step)	323 mm	1'1"	323 mm	1'1"	323 mm	1'1"
Ground clearance (AWD guard)	318 mm	1'1"	318 mm	1'1"	318 mm	1'1"
Ground clearance (485 kg/1170 lb counterweight)	287 mm	11"	287 mm	11"	287 mm	11"
5) Rear axle centerline to front grill	2705 mm	8'10"	2705 mm	8'10"	2705 mm	8'10"
Front wheel tread gauge	1895 mm	6'3"	1895 mm	6'3"	1895 mm	6'3"
Rear wheel tread gauge	1714 mm	5'7"	1714 mm	5'7"	1714 mm	5'7"
6) Wheelbase (AWD)	2200 mm	7'3"	2200 mm	7'3"	2200 mm	7'3"

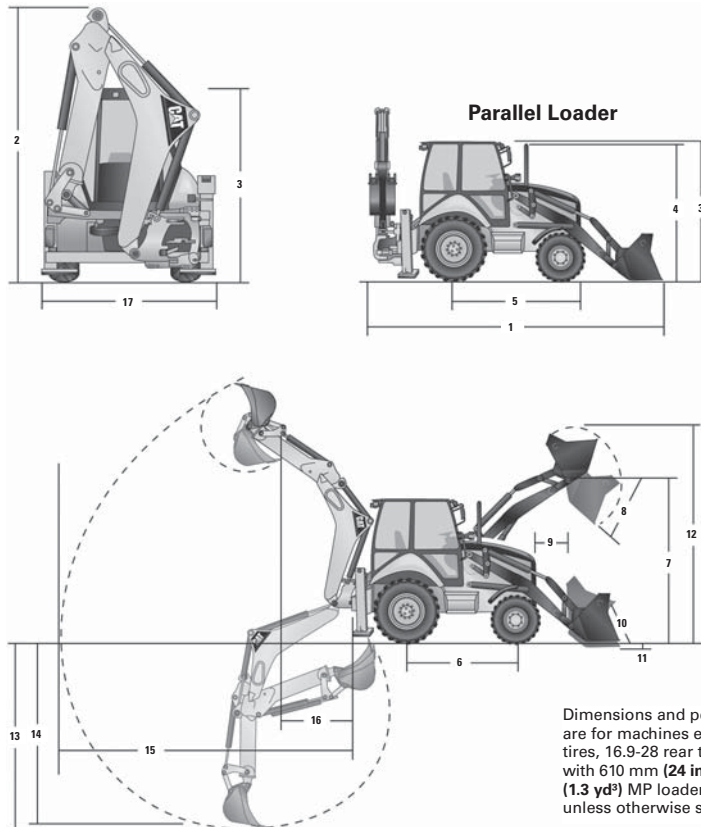

Dimensions and performance specifications shown are for machines equipped with 12.5/80-18 front tires, 16.9-28 rear tires, standard cab, standard stick with 610 mm (24 in) standard duty bucket, and 1.0 m³ (1.3 yd³) MP loader bucket and standard equipment unless otherwise specified.

MACHINE DIMENSIONS	Narrow Frame	
	Multi Purpose 0.96 m ³ (1.25 yd ³)	
1) Overall length (loader on ground)	7353 mm	24'1"
Overall transport length	5704 mm	18'9"
2) Overall transport height S-Stick	3779 mm	12'5"
Overall transport height E-Stick	3771 mm	12'4"
Overall width (Standard)	2352 mm	7'9"
Overall width (Narrow)	2352 mm	7'9"
3) Height to top of cab/canopy	2897 mm	9'6"
4) Height to top of exhaust stack	2744 mm	9'0"
Height to loader hinge pin (transport)	318 mm	1'1"
Ground clearance (stabilizer feet)	336 mm	1'1"
Ground clearance (LH step)	323 mm	1'1"
Ground clearance (AWD guard)	318 mm	1'1"
Ground clearance (485 kg/1170 lb counterweight)	287 mm	11"
5) Rear axle centerline to front grill	2705 mm	8'10"
Front wheel tread gauge	1895 mm	6'3"
Rear wheel tread gauge	1714 mm	5'7"
6) Wheelbase (AWD)	2200 mm	7'3"

LOADER BUCKET DIMENSIONS AND PERFORMANCE	Standard Frame					
	General Purpose 1.0 m ³ (1.31 yd ³)		Multi Purpose 1.03 m ³ (1.35 yd ³)		Multi Purpose with Forks 1.03 m ³ (1.35 yd ³)	
Capacity (SAE) rated	1.0 m ³	1.31 yd ³	1.03 m ³	1.35 yd ³	1.03 m ³	1.35 yd ³
Width	2406 mm	95"	2406 mm	95"	2406 mm	95"
Lift capacity at maximum height	3817 kg	8415 lb	3580 kg	3402 lb	3402 kg	7500 lb
Lift breakout force	54.8 kN	12,324 lbf	53.3 kN	11,993 lbf	51.7 kN	11,623 lbf
Tilt breakout force	54.8 kN	12,330 lbf	60.3 kN	13,561 lbf	59.4 kN	13,354 lbf
7) Maximum hinge pin height	3497 mm	11'6"	3497 mm	11'6"	3497 mm	11'6"
8) Dump angle at full height		45°		45°		45°
Dump height at maximum angle	2796 mm	9'2"	2823 mm	9'3"	2823 mm	9'3"
9) Dump reach at maximum angle	805 mm	2'8"	731 mm	2'5"	731 mm	2'5"
10) Maximum bucket rollback at ground level		38°		39°		39°
11) Digging depth	61 mm	2"	94 mm	4"	94 mm	4"
Maximum grading angle		114°		116°		116°
Width of dozer cutting edge		N/A		N/A		N/A
Grill to bucket cutting edge, carry position	1467 mm	4'10"	1419 mm	4'8"	1419 mm	4'8"
12) Maximum operating height	4394 mm	14'5"	4427 mm	14'6"	4883 mm	16'0"
Jaw opening maximum		N/A	790 mm	2'7"	790 mm	2'7"
Bucket jaw clamping force		N/A	61 kN	13,699 lbf	61 kN	13,699 lbf
Weight (does not include teeth or forks)	428 kg	942 lb	611 kg	1347 lb	705 kg	1554 lb

LOADER BUCKET DIMENSIONS AND PERFORMANCE	Narrow Frame	
	Multi Purpose 0.96 m ³ (1.25 yd ³)	
Capacity (SAE) rated	0.96 m ³	1.25 yd ³
Width	2262 mm	89"
Lift capacity at maximum height	3592 kg	7919 lb
Lift breakout force	53.5 kN	12,018 lbf
Tilt breakout force	60.4 kN	13,588 lbf
7) Maximum hinge pin height	3497 mm	11'6"
8) Dump angle at full height		45°
Dump height at maximum angle	2823 mm	9'3"
9) Dump reach at maximum angle	731 mm	2'5"
10) Maximum bucket rollback at ground level		39°
11) Digging depth	94 mm	4"
Maximum grading angle		116°
Width of dozer cutting edge		N/A
Grill to bucket cutting edge, carry position	1419 mm	4'8"
12) Maximum operating height	4396 mm	14'5"
Jaw opening maximum	790 mm	2'7"
Bucket jaw clamping force	61 kN	13,699 lbf
Weight (does not include teeth or forks)	842 kg	1856 lb

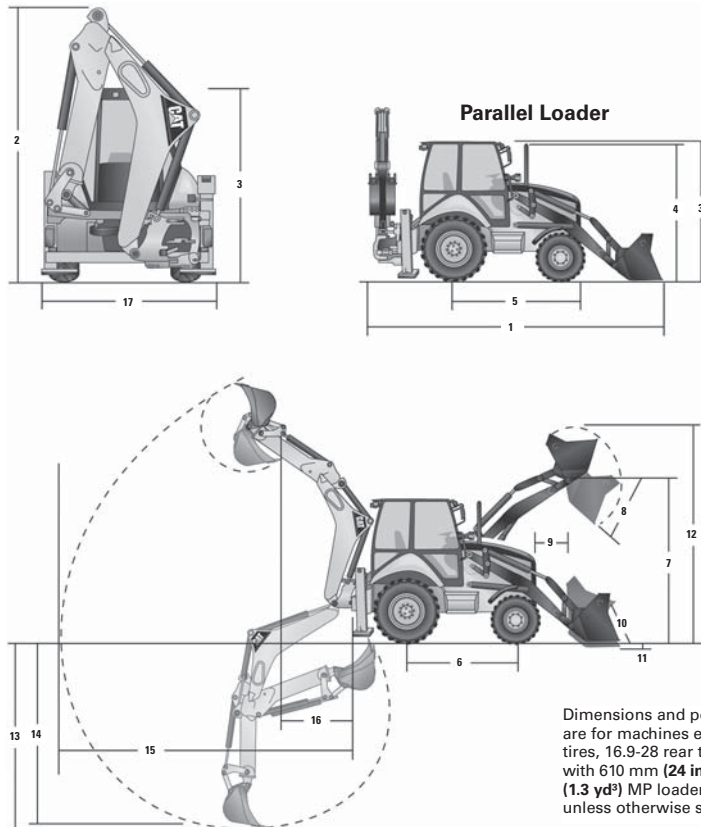

Dimensions and performance specifications shown are for machines equipped with 12.5/80-18 front tires, 16.9-28 rear tires, standard cab, standard stick with 610 mm (24 in) standard duty bucket, and 1.0 m³ (1.3 yd³) MP loader bucket and standard equipment unless otherwise specified.

BACKHOE DIMENSIONS AND PERFORMANCE	Standard Stick		Extendible Stick Retracted		Extendible Stick Extended	
	13) Digging depth, manufacturers maximum	4775 mm	14'8"	4778 mm	15'8"	5696 mm
14) Digging depth, 610 mm (2'0") flat bottom	4235 mm	13'11"	4239 mm	13'11"	5235 mm	17'2"
15) Reach from swing pivot at ground line	5650 mm	18'6"	5655 mm	18'7"	6581 mm	21'7"
Loading height	4016 mm	13'2"	4025 mm	13'2"	4630 mm	15'2"
16) Loading reach	1669 mm	5'6"	1617 mm	5'4"	2475 mm	8'1"
Swing arc	180°		180°		180°	
Bucket rotation	205°		205°		205°	
17) Stabilizer width	2352 mm	7'9"	2352 mm	7'9"	2352 mm	7'9"
Bucket dig force	63.5 kN	14,264 lbf	63.4 kN	14,258 lbf	63.4 kN	14,258 lbf
Stick dig force	36.2 kN	8132 lbf	36.9 kN	8295 lbf	27.0 kN	6066 lbf
Total side shift travel (Standard frame)	1258 mm	4'2"	1258 mm	4'2"	1258 mm	4'2"
Total side shift travel (Narrow frame)	1096 mm	3'7"	1096 mm	3'7"	1096 mm	3'7"

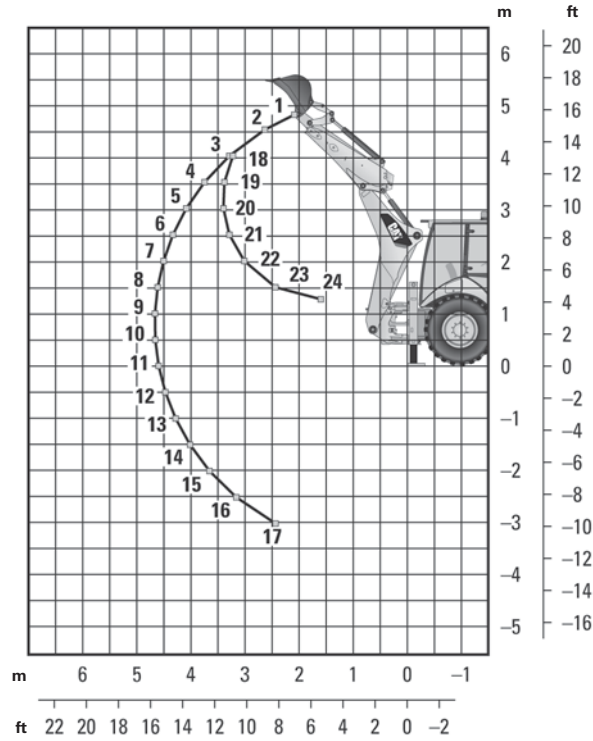

Standard Stick

Boom Lifting

1	1317 kg	2897 lb
2	1459 kg	3210 lb
3	1514 kg	3331 lb
4	1506 kg	3313 lb
5	1478 kg	3251 lb
6	1442 kg	3173 lb
7	1404 kg	3089 lb
8	1366 kg	3006 lb
9	1330 kg	2925 lb
10	1295 kg	2849 lb
11	1262 kg	2777 lb
12	1232 kg	2711 lb
13	1205 kg	2652 lb
14	1182 kg	2601 lb
15	1165 kg	2563 lb
16	1158 kg	2549 lb
17	1184 kg	2604 lb

Stick Lifting

18	2150 kg	4730 lb
19	2131 kg	4688 lb
20	2113 kg	4648 lb
21	2200 kg	4839 lb
22	2450 kg	5391 lb
23	3219 kg	7082 lb
24	5708 kg	12,558 lb

Lift Capacities are over-end values. Machine equipped with AWD, standard cab, 1.0 m³ (1.31 yd³) multi-purpose bucket, and no counterweight.

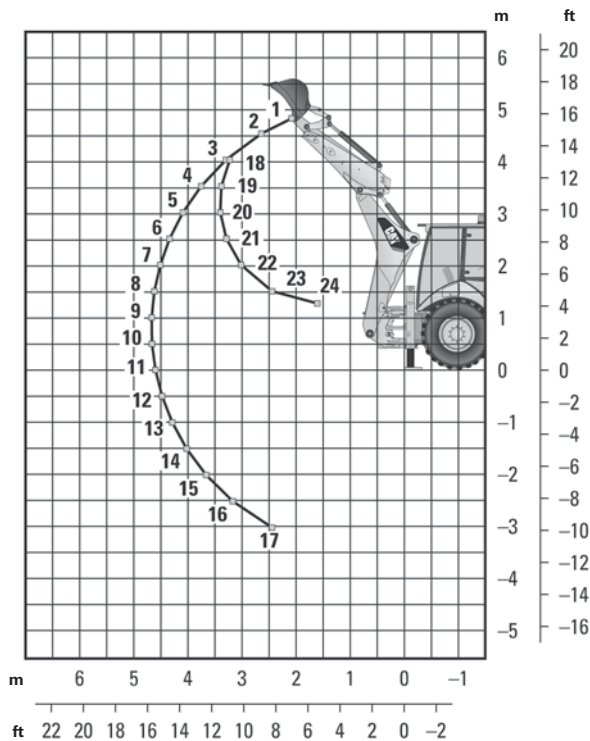

Extendible Stick Retracted – 4264 mm (14'0")

Boom Lifting

1	1234 kg	2714 lb
2	1353 kg	2977 lb
3	1388 kg	3054 lb
4	1370 kg	3013 lb
5	1335 kg	2936 lb
6	1294 kg	2846 lb
7	1251 kg	2753 lb
8	1210 kg	2661 lb
9	1169 kg	2572 lb
10	1131 kg	2488 lb
11	1095 kg	2408 lb
12	1061 kg	2333 lb
13	1029 kg	2264 lb
14	1001 kg	2202 lb
15	977 kg	2149 lb
16	959 kg	2111 lb
17	962 kg	2117 lb

Stick Lifting

18	2094 kg	4608 lb
19	2005 kg	4410 lb
20	1984 kg	4364 lb
21	2066 kg	4544 lb
22	2306 kg	5074 lb
23	3047 kg	6704 lb
24	5429 kg	11,945 lb

Lift Capacities are over-end values. Machine equipped with AWD, standard cab, 1.0 m³ (1.31 yd³) multi-purpose bucket, and no counterweight.

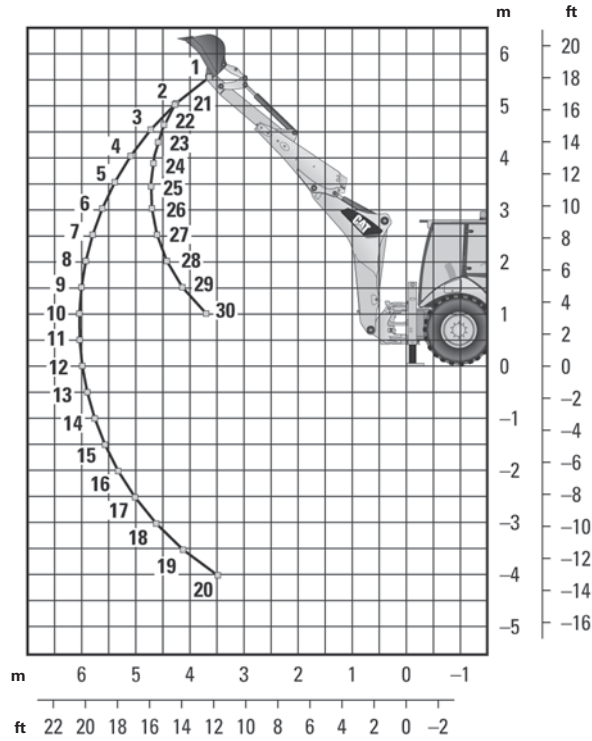

Extendible Stick Extended – 4264 mm (14'0")

Boom Lifting

1	720 kg	1585 lb
2	867 kg	1908 lb
3	944 kg	2077 lb
4	975 kg	2146 lb
5	985 kg	2168 lb
6	984 kg	2164 lb
7	976 kg	2147 lb
8	964 kg	2121 lb
9	950 kg	2091 lb
10	936 kg	2059 lb
11	921 kg	2026 lb
12	907 kg	1994 lb
13	893 kg	1965 lb
14	881 kg	1939 lb
15	872 kg	1917 lb
16	865 kg	1903 lb
17	864 kg	1900 lb
18	872 kg	1918 lb
19	900 kg	1979 lb
20	998 kg	2195 lb

Stick Lifting

21	1109 kg	2440 lb
22	1328 kg	2922 lb
23	1417 kg	3118 lb
24	1409 kg	3101 lb
25	1437 kg	3161 lb
26	1507 kg	3315 lb
27	1641 kg	3611 lb
28	1905 kg	4190 lb
29	2603 kg	5727 lb
30	6145 kg	13,519 lb

Lift Capacities are over-end values. Machine equipped with AWD, standard cab, 1.0 m³ (1.31 yd³) multi-purpose bucket, and no counterweight.

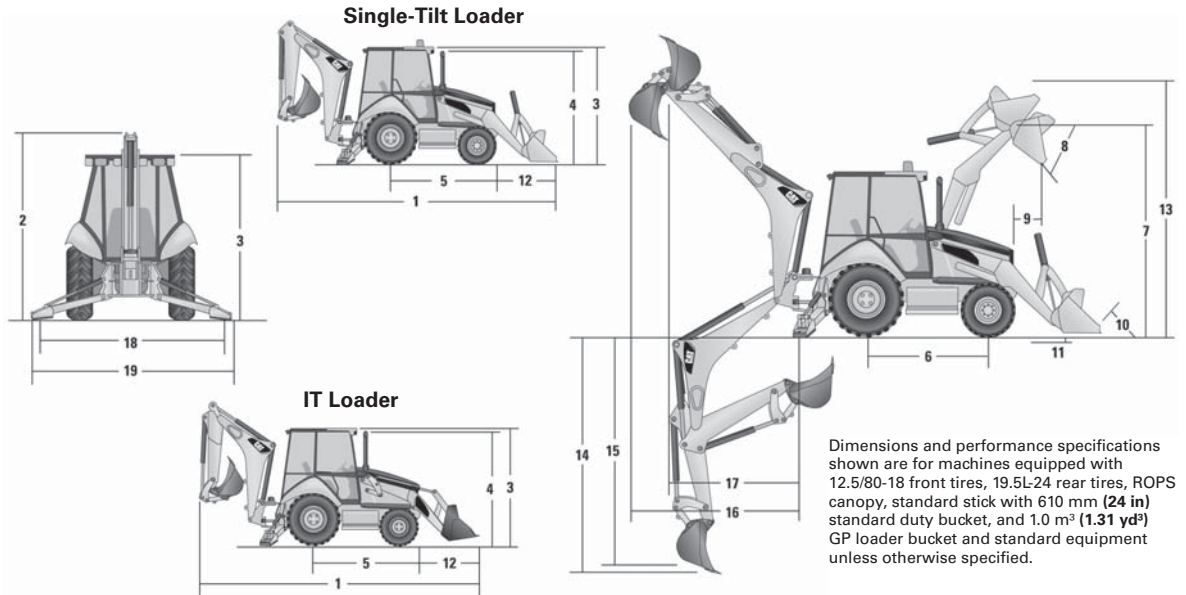

MACHINE DIMENSIONS	Single-Tilt Loader							
	General Purpose 0.96 m ³ (1.25 yd ³)		General Purpose 1.0 m ³ (1.31 yd ³)		General Purpose 1.07 m ³ (1.4 yd ³)		General Purpose 1.15 m ³ (1.5 yd ³)	
1) Overall transport length	7310 mm	24'0"	7277 mm	23'10"	7349 mm	24'1"	7349 mm	24'1"
Overall length	7282 mm	23'11"	7237 mm	23'9"	7302 mm	23'11"	7302 mm	23'11"
2) Overall transport height S-stick	3577 mm	11'9"	3577 mm	11'9"	3577 mm	11'9"	3577 mm	11'9"
Overall transport height E-stick	3631 mm	11'11"	3631 mm	11'11"	3631 mm	11'11"	3631 mm	11'11"
Overall width	2322 mm	7'7"	2322 mm	7'7"	2322 mm	7'7"	2322 mm	7'7"
3) Height to top of cab/canopy	2819 mm	9'3"	2819 mm	9'3"	2819 mm	9'3"	2819 mm	9'3"
4) Height to top of exhaust stack	2744 mm	9'0"	2744 mm	9'0"	2744 mm	9'0"	2744 mm	9'0"
Ground clearance (LH step)	294 mm	1'0"	294 mm	1'0"	294 mm	1'0"	294 mm	1'0"
Ground clearance (AWD guard)	294 mm	1'0"	294 mm	1'0"	294 mm	1'0"	294 mm	1'0"
Ground clearance (485 kg/ 1170 lb counterweight)	274 mm	11"	274 mm	11"	274 mm	11"	274 mm	11"
5) Rear axle centerline to front grill	2705 mm	8'10"	2705 mm	8'10"	2705 mm	8'10"	2705 mm	8'10"
Front wheel tread gauge	1895 mm	6'3"	1895 mm	6'3"	1895 mm	6'3"	1895 mm	6'3"
Rear wheel tread gauge	1714 mm	5'7"	1714 mm	5'7"	1714 mm	5'7"	1714 mm	5'7"
6) Wheelbase (2WD/AWD)	2200 mm	7'3"	2200 mm	7'3"	2200 mm	7'3"	2200 mm	7'3"

MACHINE DIMENSIONS	Single-Tilt Loader							
	Multi Purpose 1.0 m ³ (1.31 yd ³)		Multi Purpose 1.07 m ³ (1.4 yd ³)		Multi Purpose with Forks 1.0 m ³ (1.31 yd ³)		Multi Purpose with Forks 1.07 m ³ (1.4 yd ³)	
1) Overall transport length	7274 mm	23'10"	7274 mm	23'10"	7274 mm	23'10"	7274 mm	23'10"
Overall length	7200 mm	23'7"	7200 mm	23'7"	7200 mm	23'7"	7200 mm	23'7"
2) Overall transport height S-stick	3577 mm	11'9"	3577 mm	11'9"	3577 mm	11'9"	3577 mm	11'9"
Overall transport height E-stick	3631 mm	11'11"	3631 mm	11'11"	3631 mm	11'11"	3631 mm	11'11"
Overall width	2322 mm	7'7"	2322 mm	7'7"	2322 mm	7'7"	2322 mm	7'7"
3) Height to top of cab/canopy	2819 mm	9'3"	2819 mm	9'3"	2819 mm	9'3"	2819 mm	9'3"
4) Height to top of exhaust stack	2744 mm	9'0"	2744 mm	9'0"	2744 mm	9'0"	2744 mm	9'0"
Ground clearance (LH step)	294 mm	1'0"	294 mm	1'0"	294 mm	1'0"	294 mm	1'0"
Ground clearance (AWD guard)	294 mm	1'0"	294 mm	1'0"	294 mm	1'0"	294 mm	1'0"
Ground clearance (485 kg/ 1170 lb counterweight)	274 mm	11"	274 mm	11"	274 mm	11"	274 mm	11"
5) Rear axle centerline to front grill	2705 mm	8'10"	2705 mm	8'10"	2705 mm	8'10"	2705 mm	8'10"
Front wheel tread gauge	1895 mm	6'3"	1895 mm	6'3"	1895 mm	6'3"	1895 mm	6'3"
Rear wheel tread gauge	1714 mm	5'7"	1714 mm	5'7"	1714 mm	5'7"	1714 mm	5'7"
6) Wheelbase (2WD/AWD)	2200 mm	7'3"	2200 mm	7'3"	2200 mm	7'3"	2200 mm	7'3"

MACHINE DIMENSIONS	IT Loader with Quick Coupler					
	General Purpose 0.96 m ³ (1.25 yd ³)		General Purpose 1.0 m ³ (1.31 yd ³)		General Purpose 1.15 m ³ (1.5 yd ³)	
1) Overall transport length	7423 mm	24'4"	7391 mm	24'3"	7420 mm	24'4"
Overall length	7430 mm	24'5"	7385 mm	24'3"	7428 mm	24'4"
2) Overall transport height S-stick	3577 mm	11'9"	3577 mm	11'9"	3577 mm	11'9"
Overall transport height E-stick	3631 mm	11'11"	3631 mm	11'11"	3631 mm	11'11"
Overall width	2322 mm	7'7"	2322 mm	7'7"	2322 mm	7'7"
3) Height to top of cab/canopy	2819 mm	9'3"	2819 mm	9'3"	2819 mm	9'3"
4) Height to top of exhaust stack	2744 mm	9'0"	2744 mm	9'0"	2744 mm	9'0"
Ground clearance (LH step)	294 mm	1'0"	294 mm	1'0"	294 mm	1'0"
Ground clearance (AWD guard)	294 mm	1'0"	294 mm	1'0"	294 mm	1'0"
Ground clearance (485 kg/ 1170 lb counterweight)	274 mm	11"	274 mm	11"	274 mm	11"
5) Rear axle centerline to front grill	2705 mm	8'10"	2705 mm	8'10"	2705 mm	8'10"
Front wheel tread gauge	1895 mm	6'3"	1895 mm	6'3"	1895 mm	6'3"
Rear wheel tread gauge	1714 mm	5'7"	1714 mm	5'7"	1714 mm	5'7"
6) Wheelbase (2WD/AWD)	2200 mm	7'3"	2200 mm	7'3"	2200 mm	7'3"

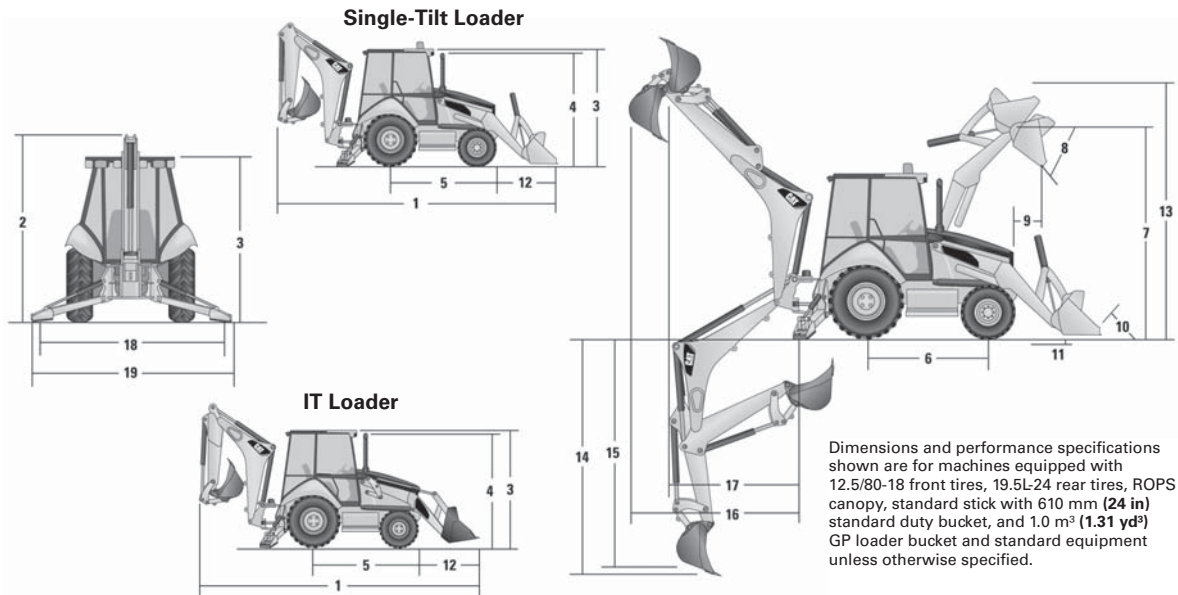

Dimensions and performance specifications shown are for machines equipped with 12.5/80-18 front tires, 19.5L-24 rear tires, ROPS canopy, standard stick with 610 mm (24 in) standard duty bucket, and 1.0 m³ (1.31 yd³) GP loader bucket and standard equipment unless otherwise specified.

MACHINE DIMENSIONS	IT Loader with Quick Coupler			
	Multi Purpose 0.96 m ³ (1.25 yd ³)		Multi Purpose 1.03 m ³ (1.35 yd ³)	
1) Overall transport length	7352 mm	24'1"	7352 mm	24'1"
Overall length	7338 mm	24'1"	7338 mm	24'1"
2) Overall transport height S-stick	3577 mm	11'9"	3577 mm	11'9"
Overall transport height E-stick	3631 mm	11'11"	3631 mm	11'11"
Overall width	2322 mm	7'7"	2322 mm	7'7"
3) Height to top of cab/canopy	2819 mm	9'3"	2819 mm	9'3"
4) Height to top of exhaust stack	2744 mm	9'0"	2744 mm	9'0"
Ground clearance (LH step)	294 mm	1'0"	294 mm	1'0"
Ground clearance (AWD guard)	294 mm	1'0"	294 mm	1'0"
Ground clearance (485 kg/ 1170 lb counterweight)	274 mm	11"	274 mm	11"
5) Rear axle centerline to front grill	2705 mm	8'10"	2705 mm	8'10"
Front wheel tread gauge	1895 mm	6'3"	1895 mm	6'3"
Rear wheel tread gauge	1714 mm	5'7"	1714 mm	5'7"
6) Wheelbase (2WD/AWD)	2200 mm	7'3"	2200 mm	7'3"

LOADER BUCKET DIMENSIONS AND PERFORMANCE	Single-Tilt Loader							
	General Purpose 0.96 m ³ (1.25 yd ³)		General Purpose 1.0 m ³ (1.31 yd ³)		General Purpose 1.07 m ³ (1.4 yd ³)		General Purpose 1.15 m ³ (1.5 yd ³)	
Capacity (SAE) rated	0.96 m ³	1.25 yd³	1.0 m ³	1.31 yd³	1.07 m ³	1.4 yd³	1.15 m ³	1.5 yd³
Width	2262 mm	89"	2406 mm	95"	2262 mm	89"	2406 mm	95"
Lift capacity at maximum height	3283 kg	7237 lb	3292 kg	7257 lb	3216 kg	7090 lb	3196 kg	7046 lb
Lift breakout force	49.8 kN	11,197 lbf	50.6 kN	11,367 lbf	49.3 kN	11,077 lbf	49.1 kN	11,037 lbf
Tilt breakout force	50.2 kN	11,283 lbf	53.4 kN	11,995 lbf	51.2 kN	11,518 lbf	51.1 kN	11,494 lbf
7) Maximum hinge pin height	3474 mm	11'5"	3474 mm	11'5"	3474 mm	11'5"	3474 mm	11'5"
8) Dump angle at full height		44°		44°		44°		44°
Dump height at maximum angle	2746 mm	9'0"	2777 mm	9'1"	2723 mm	8'11"	2723 mm	8'11"
9) Dump reach at maximum angle	808 mm	2'8"	775 mm	2'7"	773 mm	2'6"	773 mm	2'6"
10) Maximum bucket rollback at ground level		37°		37°		38°		39°
11) Digging depth	83 mm	3"	83 mm	3"	123 mm	5"	123 mm	5"
Maximum grading angle		112°		114°		113°		113°
Width of dozer cutting edge		N/A		N/A		N/A		N/A
12) Grill to bucket cutting edge, carry position	1487 mm	4'11"	1454 mm	4'9"	1525 mm	5'0"	1525 mm	5'0"
13) Maximum operating height	4355 mm	14'3"	4353 mm	14'3"	4395 mm	14'5"	4395 mm	14'5"
Jaw opening maximum		N/A		N/A		N/A		N/A
Bucket jaw clamping force		N/A		N/A		N/A		N/A
Weight (does not include teeth or forks)	451 kg	994 lb	462 kg	1019 lb	473 kg	1043 lb	493 kg	1087 lb

LOADER BUCKET DIMENSIONS AND PERFORMANCE	Single-Tilt Loader							
	Multi Purpose 1.0 m ³ (1.31 yd ³)		Multi Purpose 1.07 m ³ (1.4 yd ³)		Multi Purpose with Forks 1.0 m ³ (1.31 yd ³)		Multi Purpose with Forks 1.07 m ³ (1.4 yd ³)	
Capacity (SAE) rated	1.0 m ³	1.31 yd³	1.07 m ³	1.4 yd³	1.0 m ³	1.31 yd³	1.07 m ³	1.4 yd³
Width	2279 mm	90"	2425 mm	95"	2279 mm	90"	2425 mm	95"
Lift capacity at maximum height	3097 kg	6828 lb	3068 kg	6764 lb	2982 kg	6575 lb	2953 kg	6511 lb
Lift breakout force	49.0 kN	11,020 lbf	48.8 kN	10,964 lbf	47.5 kN	10,685 lbf	47.3 kN	10,629 lbf
Tilt breakout force	57.6 kN	12,938 lbf	57.4 kN	12,905 lbf	56.6 kN	12,733 lbf	56.5 kN	12,700 lbf
7) Maximum hinge pin height	3474 mm	11'5"	3474 mm	11'5"	3474 mm	11'5"	3474 mm	11'5"
8) Dump angle at full height		44°		44°		44°		44°
Dump height at maximum angle	2798 mm	9'2"	2798 mm	9'2"	2798 mm	9'2"	2798 mm	9'2"
9) Dump reach at maximum angle	716 mm	2'4"	716 mm	2'4"	716 mm	2'4"	716 mm	2'4"
10) Maximum bucket rollback at ground level		38°		38°		38°		38°
11) Digging depth	110 mm	4"	110 mm	4"	110 mm	4"	110 mm	4"
Maximum grading angle		116°		116°		116°		116°
Width of dozer cutting edge	2262 mm	7'5"	2406 mm	7'11"	2262 mm	7'5"	2406 mm	7'11"
12) Grill to bucket cutting edge, carry position	1451 mm	4'9"	1451 mm	4'9"	1451 mm	4'9"	1451 mm	4'9"
13) Maximum operating height	4404 mm	14'5"	4404 mm	14'5"	4878 mm	16'0"	4878 mm	16'0"
Jaw opening maximum	790 mm	2'7"	790 mm	2'7"	790 mm	2'7"	790 mm	2'7"
Bucket jaw clamping force	55.7 kN	12,521 lbf	55.7 kN	12,521 lbf	55.7 kN	12,521 lbf	55.7 kN	12,521 lbf
Weight (does not include teeth or forks)	745 kg	1642 lb	774 kg	1706 lb	915 kg	2017 lb	936 kg	2064 lb

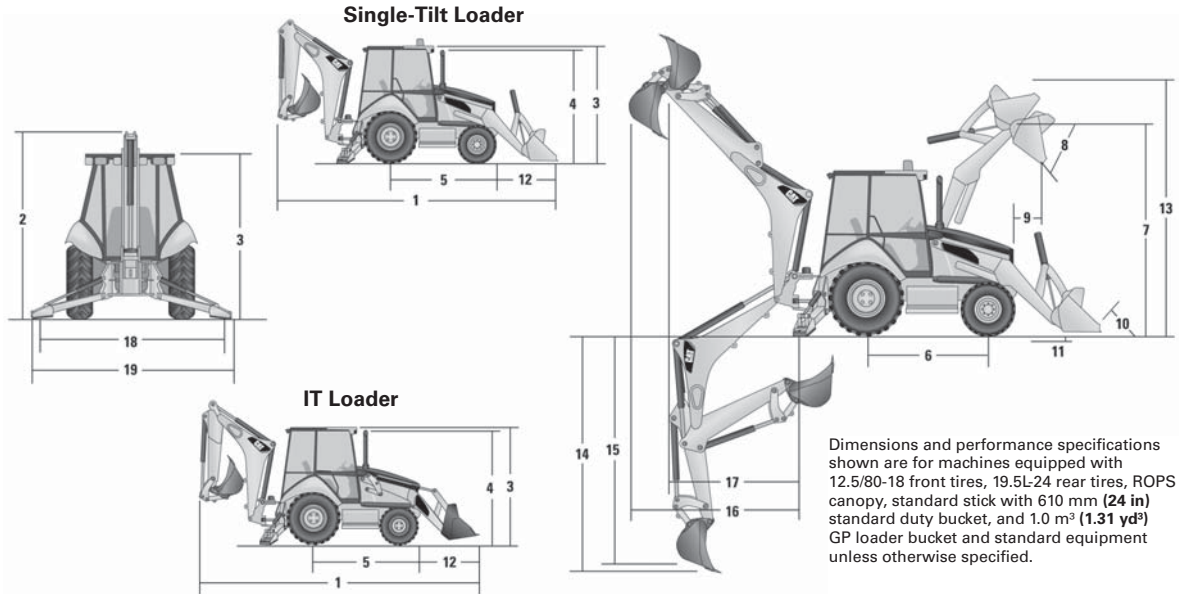

LOADER BUCKET DIMENSIONS AND PERFORMANCE	IT Loader with Quick Coupler					
	General Purpose 0.96 m ³ (1.25 yd ³)		General Purpose 1.0 m ³ (1.31 yd ³)		General Purpose 1.15 m ³ (1.5 yd ³)	
Capacity (SAE) rated	0.96 m ³	1.25 yd³	1.0 m ³	1.31 yd³	1.15 m ³	1.5 yd³
Width	2262 mm	89"	2406 mm	95"	2406 mm	95"
Lift capacity at maximum height	3716 kg	8193 lb	3707 kg	8173 lb	3682 kg	8117 lb
Lift breakout force	51.1 kN	11,484 lbf	51.5 kN	11,575 lbf	50.8 kN	11,415 lbf
Tilt breakout force	46.3 kN	10,411 lbf	48.9 kN	10,999 lbf	46.1 kN	10,371 lbf
7) Maximum hinge pin height	3490 mm	11'5"	3490 mm	11'5"	3490 mm	11'5"
8) Dump angle at full height		44°		44°		44°
Dump height at maximum angle	2679 mm	8'9"	2710 mm	8'11"	2680 mm	8'10"
9) Dump reach at maximum angle	869 mm	2'10"	836 mm	2'9"	868 mm	2'10"
10) Maximum bucket rollback at ground level		40°		40°		40°
11) Digging depth	105 mm	4"	105 mm	4"	105 mm	4"
Maximum grading angle		110°		111°		110°
Width of dozer cutting edge		N/A		N/A		N/A
12) Grill to bucket cutting edge, carry position	1600 mm	5'3"	1568 mm	5'2"	1597 mm	5'3"
13) Maximum operating height	4407 mm	14'6"	4407 mm	14'6"	4477 mm	14'8"
Jaw opening maximum		N/A		N/A		N/A
Bucket jaw clamping force		N/A		N/A		N/A
Weight (does not include teeth or forks)	447 kg	985 lb	457 kg	1008 lb	481 kg	1060 lb

LOADER BUCKET DIMENSIONS AND PERFORMANCE	IT Loader with Quick Coupler			
	Multi Purpose 1.0 m ³ (1.31 yd ³)		Multi Purpose 1.07 m ³ (1.4 yd ³)	
Capacity (SAE) rated	1.0 m ³	1.31 yd³	1.07 m ³	1.4 yd³
Width	2279 mm	90"	2425 mm	95"
Lift capacity at maximum height	3448 kg	7601 lb	3419 kg	7537 lb
Lift breakout force	49.7 kN	11,168 lbf	49.4 kN	11,108 lbf
Tilt breakout force	50.4 kN	11,325 lbf	50.2 kN	11,288 lbf
7) Maximum hinge pin height	3490 mm	11'5"	3490 mm	11'5"
8) Dump angle at full height		44°		44°
Dump height at maximum angle	2745 mm	9'0"	2745 mm	9'0"
9) Dump reach at maximum angle	814 mm	2'8"	814 mm	2'8"
10) Maximum bucket rollback at ground level		39°		39°
11) Digging depth	95 mm	4"	95 mm	4"
Maximum grading angle		112°		112°
Width of dozer cutting edge	2262 mm	7'5"	2406 mm	7'11"
12) Grill to bucket cutting edge, carry position	1529 mm	5'0"	1529 mm	5'0"
13) Maximum operating height	4480 mm	14'8"	4480 mm	14'8"
Jaw opening maximum	790 mm	2'7"	790 mm	2'7"
Bucket jaw clamping force	55.7 kN	12,521 lbf	55.7 kN	12,521 lbf
Weight (does not include teeth or forks)	724 kg	1596 lb	753 kg	1660 lb

BACKHOE DIMENSIONS AND PERFORMANCE	Standard Stick		Extendible Stick Retracted		Extendible Stick Extended	
14) Digging depth, SAE (maximum)	4686 mm	15'4"	4795 mm	15'9"	5935 mm	19'6"
15) Digging depth, 610 mm (2'0") flat bottom	4660 mm	15'3"	4766 mm	15'8"	5906 mm	19'5"
Reach from rear axle centerline at ground line	7133 mm	23'5"	7227 mm	23'9"	8316 mm	27'3"
16) Reach from swing pivot at ground line	6043 mm	19'10"	6137 mm	20'2"	7226 mm	23'8"
Maximum operating height	6007 mm	19'9"	6075 mm	19'11"	6958 mm	22'10"
Loading height	3961 mm	13'0"	3921 mm	12'10"	4533 mm	14'10"
17) Loading reach	1855 mm	6'1"	2022 mm	6'8"	3003 mm	9'10"
Swing arc		180°		180°		180°
Bucket rotation		205°		204°		204°
18) Stabilizer spread, operating position (center of pad)	3310 mm	10'10"	3310 mm	10'10"	3310 mm	10'10"
19) Stabilizer spread, operating position (outside edge of pad)	3770 mm	12'4"	3770 mm	12'4"	3770 mm	12'4"
Stabilizer spread, transport position	2322 mm	7'7"	2322 mm	7'7"	2322 mm	7'7"
Bucket dig force	71.9 kN	16,156 lbf	70.9 kN	15,932 lbf	70.9 kN	15,932 lbf
Stick dig force	44.8 kN	10,067 lbf	43.8 kN	9856 lbf	32.4 kN	7287 lbf

DIMENSIONS WITH FORKS/ MATERIAL-HANDLING ARM	Cat 430F2 IT Operating Specifications with Forks					
Fork Tine Length	1070 mm (3'6")		1220 mm (4'0")		1370 mm (4'6")	
Operating load (SAE J1197)	2448 kg	5397 lb	2368 kg	5220 lb	2292 kg	5054 lb
SAE load center	535 mm	1'9"	610 mm	2'0"	685 mm	2'3"
Operating load (CEN 474-4)	2772 kg	6111 lb	2749 kg	6062 lb	2726 kg	6009 lb
CEN load center	500 mm	1'8"	500 mm	1'8"	500 mm	1'8"
Overall length (A) (forks on ground)	7822 mm	25'8"	7973 mm	26'2"	8121 mm	26'8"

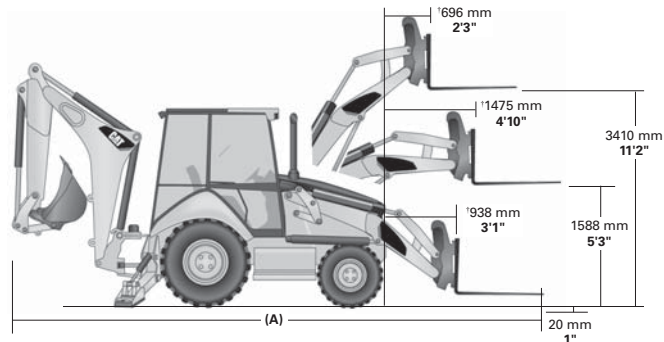

Operating load is hydraulic and tip limited.

†Measured from nose of machine.

DIMENSIONS WITH FORKS/ MATERIAL-HANDLING ARM	Cat 430F IT Operating Specifications with Material-Handling Arm					
Material-Handling Arm Position	Retracted		Mid-Position		Extended	
Operating load (SAE J1197 and CEN 474-4)	1058 kg	2333 lb	674 kg	1487 lb	495 kg	1092 lb
Overall length, maximum	9008 mm	29'7"	10 005 mm	32'10"	11 005 mm	36'1"

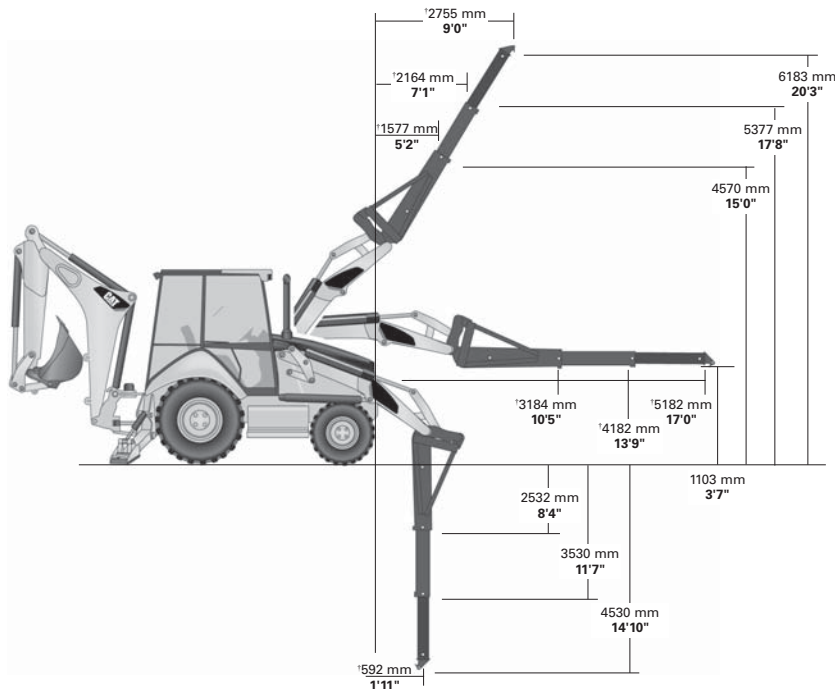

Operating load is hydraulic and tip limited.

Dimensions and performance specifications shown are for 4WD machines equipped with 12.5/80-18 I-3 front tires, 19.5L-24 R-4 ATU rear tires, ROPS canopy, standard stick with 610 mm (24 in) standard duty bucket, and 1.00 m³ (1.31 yd³) loader bucket and standard equipment unless otherwise specified.

†Measured from nose of machine.

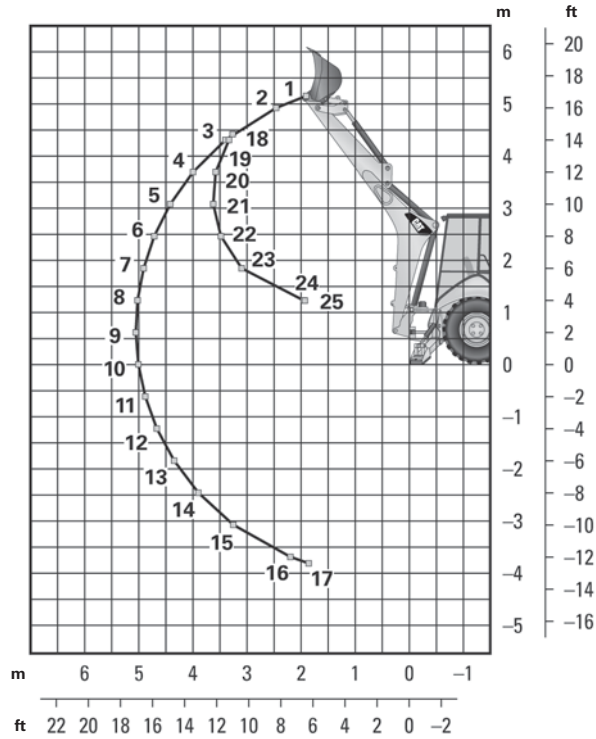

Standard Stick

Boom Lifting

1	1508 kg	3318 lb
2	1782 kg	3921 lb
3	1936 kg	4258 lb
4	1925 kg	4236 lb
5	1878 kg	4131 lb
6	1819 kg	4001 lb
7	1757 kg	3866 lb
8	1698 kg	3735 lb
9	1641 kg	3610 lb
10	1588 kg	3493 lb
11	1539 kg	3387 lb
12	1496 kg	3291 lb
13	1459 kg	3211 lb
14	1432 kg	3151 lb
15	1425 kg	3136 lb
16	1503 kg	3307 lb
17	1573 kg	3461 lb

Stick Lifting

18	2453 kg	5397 lb
19	2636 kg	5800 lb
20	2830 kg	6226 lb
21	2773 kg	6100 lb
22	2906 kg	6394 lb
23	3367 kg	7408 lb
24	6152 kg	13,535 lb
25	6240 kg	13,728 lb

Lift Capacities are over-end values. Machine equipped with AWD, OROPS, 1.0 m³ (1.31 yd³) general purpose bucket, and 460 kg (1015 lb) counterweight.

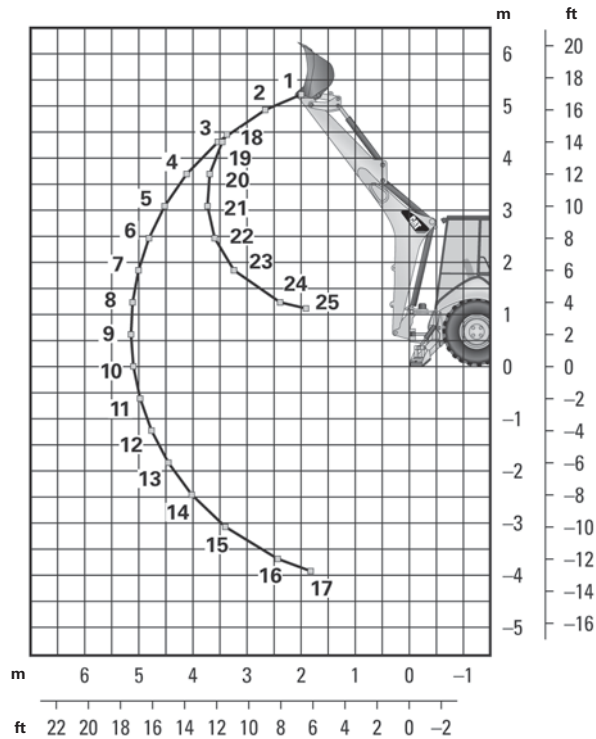

Extendible Stick Retracted

Boom Lifting

1	1250 kg	2751 lb
2	1541 kg	3391 lb
3	1663 kg	3659 lb
4	1654 kg	3639 lb
5	1610 kg	3542 lb
6	1555 kg	3421 lb
7	1497 kg	3294 lb
8	1441 kg	3169 lb
9	1386 kg	3049 lb
10	1335 kg	2936 lb
11	1287 kg	2832 lb
12	1244 kg	2738 lb
13	1207 kg	2656 lb
14	1178 kg	2593 lb
15	1166 kg	2565 lb
16	1211 kg	2665 lb
17	1316 kg	2896 lb

Stick Lifting

18	2158 kg	4747 lb
19	2367 kg	5208 lb
20	2538 kg	5583 lb
21	2486 kg	5469 lb
22	2599 kg	5719 lb
23	2979 kg	6553 lb
24	4516 kg	9934 lb
25	6083 kg	13,382 lb

Lift Capacities are over-end values. Machine equipped with AWD, OROPS, 1.0 m³ (1.31 yd³) general purpose bucket, and 460 kg (1015 lb) counterweight.

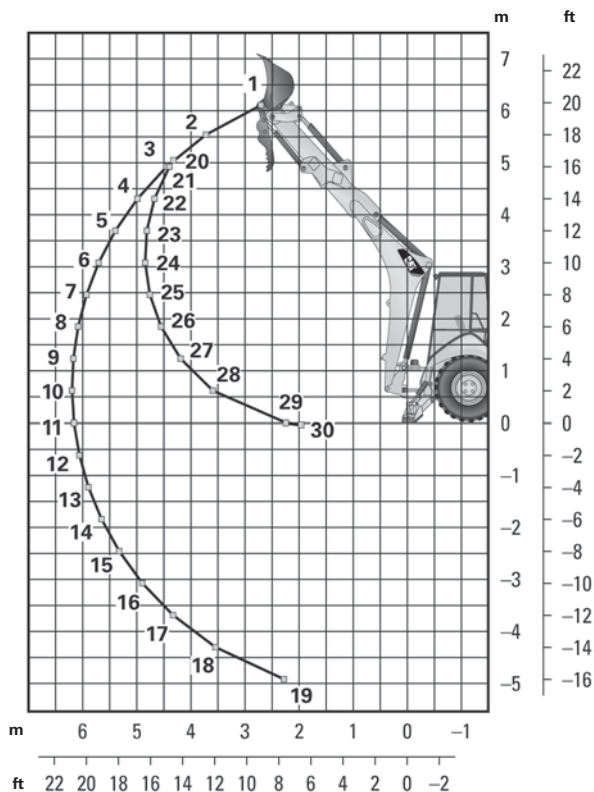

Extendible Stick Extended

Boom Lifting

1	679 kg	1493 lb
2	1017 kg	2237 lb
3	1124 kg	2474 lb
4	1158 kg	2547 lb
5	1161 kg	2553 lb
6	1149 kg	2527 lb
7	1129 kg	2484 lb
8	1106 kg	2433 lb
9	1081 kg	2378 lb
10	1056 kg	2323 lb
11	1032 kg	2270 lb
12	1009 kg	2220 lb
13	989 kg	2176 lb
14	972 kg	2138 lb
15	959 kg	2111 lb
16	954 kg	2100 lb
17	963 kg	2119 lb
18	1005 kg	2210 lb
19	1211 kg	2663 lb

Stick Lifting

20	1197 kg	2633 lb
21	1277 kg	2810 lb
22	1565 kg	3444 lb
23	1735 kg	3817 lb
24	1715 kg	3774 lb
25	1753 kg	3856 lb
26	1860 kg	4092 lb
27	2079 kg	4575 lb
28	2563 kg	5638 lb
29	4910 kg	10,802 lb
30	5883 kg	12,943 lb

Lift Capacities are over-end values. Machine equipped with AWD, OROPS, 1.0 m³ (1.31 yd³) general purpose bucket, and 460 kg (1015 lb) counterweight.

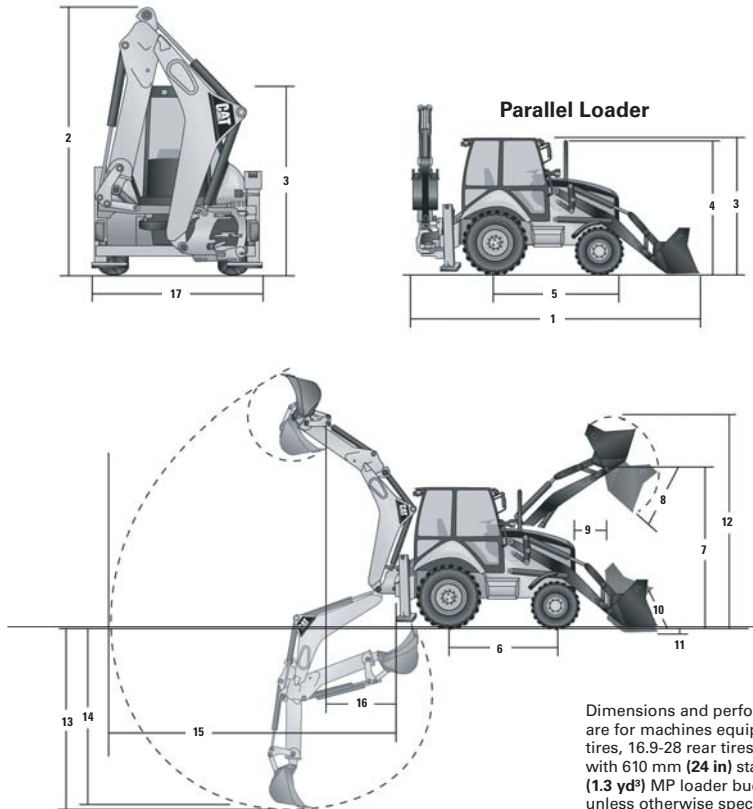

Dimensions and performance specifications shown are for machines equipped with 12.5/80-18 front tires, 16.9-28 rear tires, standard cab, standard stick with 610 mm (24 in) standard duty bucket, and 1.0 m³ (1.3 yd³) MP loader bucket and standard equipment unless otherwise specified.

MACHINE DIMENSIONS	Standard Frame					
	General Purpose 1.0 m ³ (1.31 yd ³)		Multi Purpose 1.03 m ³ (1.35 yd ³)		Multi Purpose with Forks 1.03 m ³ (1.35 yd ³)	
1) Overall length (loader on ground)	7398 mm	24'3"	7353 mm	24'1"	7353 mm	24'1"
Overall transport length	5750 mm	18'10"	5704 mm	18'9"	5704 mm	18'9"
2) Overall transport height S-Stick	3779 mm	12'5"	3779 mm	12'5"	3779 mm	12'5"
Overall transport height E-Stick	3771 mm	12'4"	3771 mm	12'4"	3771 mm	12'4"
Overall width (Standard)	2352 mm	7'9"	2352 mm	7'9"	2352 mm	7'9"
Overall width (Narrow)	2352 mm	7'9"	2352 mm	7'9"	2352 mm	7'9"
3) Height to top of cab/canopy	2897 mm	9'6"	2897 mm	9'6"	2897 mm	9'6"
4) Height to top of exhaust stack	2744 mm	9'0"	2744 mm	9'0"	2744 mm	9'0"
Height to loader hinge pin (transport)	361 mm	1'2"	318 mm	1'1"	318 mm	1'1"
Ground clearance (stabilizer feet)	333 mm	1'1"	333 mm	1'1"	333 mm	1'1"
Ground clearance (LH step)	323 mm	1'1"	323 mm	1'1"	323 mm	1'1"
Ground clearance (AWD guard)	318 mm	1'1"	318 mm	1'1"	318 mm	1'1"
Ground clearance (485 kg/1170 lb counterweight)	287 mm	11"	287 mm	11"	287 mm	11"
5) Rear axle centerline to front grill	2705 mm	8'10"	2705 mm	8'10"	2705 mm	8'10"
Front wheel tread gauge	1895 mm	6'3"	1895 mm	6'3"	1895 mm	6'3"
Rear wheel tread gauge	1714 mm	5'7"	1714 mm	5'7"	1714 mm	5'7"
6) Wheelbase (AWD)	2200 mm	7'3"	2200 mm	7'3"	2200 mm	7'3"

MACHINE DIMENSIONS	Narrow Frame		Quick Coupler			
	Multi Purpose 0.96 m ³ (1.25 yd ³)		General Purpose 1.03 m ³ (1.35 yd ³)		Multi Purpose 1.03 m ³ (1.35 yd ³)	
1) Overall length (loader on ground)	7353 mm	24'1"	7507 mm	24'8"	7402 mm	24'3"
Overall transport length	5704 mm	18'10"	5859 mm	19'3"	5754 mm	18'11"
2) Overall transport height S-Stick	3779 mm	12'5"	3779 mm	12'5"	3779 mm	12'5"
Overall transport height E-Stick	3771 mm	12'4"	3771 mm	12'4"	3771 mm	12'4"
Overall width (Standard)	2352 mm	7'9"	2352 mm	7'9"	2352 mm	7'9"
Overall width (Narrow)	2352 mm	7'9"	2352 mm	7'9"	2352 mm	7'9"
3) Height to top of cab/canopy	2897 mm	9'6"	2897 mm	9'6"	2897 mm	9'6"
4) Height to top of exhaust stack	2744 mm	9'0"	2744 mm	9'0"	2744 mm	9'0"
Height to loader hinge pin (transport)	318 mm	1'1"	354 mm	1'2"	276 mm	1'1"
Ground clearance (stabilizer feet)	333 mm	1'1"	333 mm	1'1"	333 mm	1'1"
Ground clearance (LH step)	323 mm	1'1"	323 mm	1'1"	323 mm	1'1"
Ground clearance (AWD guard)	318 mm	1'1"	318 mm	1'1"	318 mm	1'1"
Ground clearance (485 kg/1170 lb counterweight)	287 mm	1'1"	287 mm	1'1"	287 mm	1'1"
5) Rear axle centerline to front grill	2705 mm	8'10"	2705 mm	8'10"	2705 mm	8'10"
Front wheel tread gauge	1895 mm	6'3"	1895 mm	6'3"	1895 mm	6'3"
Rear wheel tread gauge	1714 mm	5'7"	1714 mm	5'7"	1714 mm	5'7"
6) Wheelbase (AWD)	2200 mm	7'3"	2200 mm	7'3"	2200 mm	7'3"

LOADER BUCKET DIMENSIONS AND PERFORMANCE	Standard Frame					
	General Purpose 1.0 m ³ (1.31 yd ³)		Multi Purpose 1.03 m ³ (1.35 yd ³)		Multi Purpose with Forks 1.03 m ³ (1.35 yd ³)	
Capacity (SAE) rated	1.0 m ³	1.31 yd ³	1.03 m ³	1.35 yd ³	1.03 m ³	1.35 yd ³
Width	2406 mm	95"	2406 mm	95"	2406 mm	95"
Lift capacity at maximum height	3817 kg	8415 lb	3580 kg	7893 lb	3402 kg	7500 lb
Lift breakout force	54.8 kN	12,324 lbf	53.3 kN	11,993 lbf	51.7 kN	11,623 lbf
Tilt breakout force	54.8 kN	12,330 lbf	60.3 kN	13,561 lbf	59.4 kN	13,354 lbf
7) Maximum hinge pin height	3497 mm	11'6"	3497 mm	11'6"	3497 mm	11'6"
8) Dump angle at full height		45°		45°		45°
Dump height at maximum angle	2796 mm	9'2"	2823 mm	9'3"	2823 mm	9'3"
9) Dump reach at maximum angle	805 mm	2'8"	731 mm	2'5"	731 mm	2'5"
10) Maximum bucket rollback at ground level		38°		39°		39°
11) Digging depth	61 mm	2"	94 mm	4"	94 mm	4"
Maximum grading angle		114°		116°		116°
Width of dozer cutting edge		N/A	2406 mm	7'11"	2406 mm	7'11"
Grill to bucket cutting edge, carry position	1467 mm	4'10"	1419 mm	4'8"	1419 mm	4'8"
12) Maximum operating height	4394 mm	14'5"	4427 mm	14'6"	4883 mm	16'0"
Jaw opening maximum		N/A	790 mm	2'7"	790 mm	2'7"
Bucket jaw clamping force		N/A	61 kN	13,699 lbf	61 kN	13,699 lbf
Weight (does not include teeth or forks)	428 kg	942 lb	611 kg	1347 lb	705 kg	1554 lb

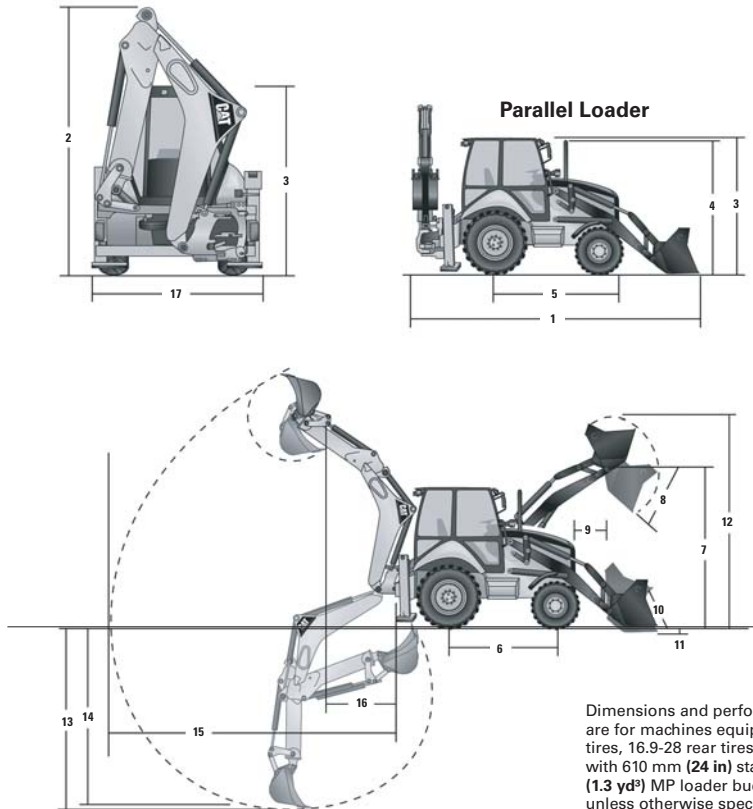

Dimensions and performance specifications shown are for machines equipped with 12.5/80-18 front tires, 16.9-28 rear tires, standard cab, standard stick with 610 mm (24 in) standard duty bucket, and 1.0 m³ (1.3 yd³) MP loader bucket and standard equipment unless otherwise specified.

LOADER BUCKET DIMENSIONS AND PERFORMANCE	Narrow Frame		Quick Coupler			
	Multi Purpose 0.96 m ³ (1.25 yd ³)		General Purpose 1.03 m ³ (1.35 yd ³)		Multi Purpose 1.03 m ³ (1.35 yd ³)	
Capacity (SAE) rated	0.96 m ³	1.25 yd³	1.03 m ³	1.35 yd³	1.03 m ³	1.35 yd³
Width	2262 mm	89"	2406 mm	95"	2406 mm	95"
Lift capacity at maximum height	3592 kg	7989 lb	3611 kg	7961 lb	3234 mm	10'7"
Lift breakout force	53.5 kN	12,018 lbf	51.8 kN	11,650 lbf	49.8 kN	11,188 lbf
Tilt breakout force	60.4 kN	13,588 lbf	48.8 kN	10,963 lbf	53.7 kN	12,075 lbf
7) Maximum hinge pin height	3497 mm	11'6"	3497 mm	11'6"	3497 mm	11'6"
8) Dump angle at full height		45°		45°		45°
Dump height at maximum angle	2823 mm	9'3"	2711 mm	8'11"	2789 mm	9'2"
9) Dump reach at maximum angle	731 mm	2'5"	837 mm	2'9"	783 mm	2'7"
10) Maximum bucket rollback at ground level		39°		39°		39°
11) Digging depth	94 mm	4"	100 mm	4"	81 mm	3"
Maximum grading angle		116°		112°		114°
Width of dozer cutting edge	2406 mm	7'11"		N/A	2406 mm	7'11"
Grill to bucket cutting edge, carry position	1419 mm	4'8"	1550 mm	5'1"	1435 mm	4'9"
12) Maximum operating height	4396 mm	14'5"	4396 mm	14'5"	4442 mm	14'7"
Jaw opening maximum		N/A	790 mm	2'7"	790 mm	2'7"
Bucket jaw clamping force		N/A	61 kN	13,699 lbf	61 kN	13,699 lbf
Weight (does not include teeth or forks)	842 kg	1856 lb	459 kg	1012 lb	697 kg	1537 lb

BACKHOE DIMENSIONS AND PERFORMANCE	Standard Stick		Extendible Stick Retracted 4264 mm (14'0")		Extendible Stick Extended 4264 mm (14'0")	
	13) Digging depth, manufacturers maximum	4775 mm	15'8"	4778 mm	15'8"	5696 mm
14) Digging depth, 610 mm (2'0") flat bottom	4235 mm	18'10"	4239 mm	13'11"	5235 mm	17'2"
15) Reach from swing pivot at ground line	5650 mm	18'6"	5655 mm	18'7"	6583 mm	21'7"
Loading height	4016 mm	13'2"	4025 mm	13'2"	4630 mm	15'2"
16) Loading reach	1669 mm	5'6"	1617 mm	5'4"	2475 mm	8'1"
Swing arc	180°		180°		180°	
Bucket rotation	205°		205°		205°	
17) Stabilizer width	2352 mm	7'9"	2352 mm	7'9"	2352 mm	7'9"
Bucket dig force	63.5 kN	14,264 lbf	63.4 kN	14,258 lbf	63.4 kN	14,258 lbf
Stick dig force	42.8 kN	9617 lbf	43.6 kN	9790 lbf	31.7 kN	7137 lbf
Total side shift travel (Standard frame)	1258 mm	4'2"	1258 mm	4'2"	1258 mm	4'2"
Total side shift travel (Narrow frame)	1096 mm	3'7"	1096 mm	3'7"	1096 mm	3'7"

BACKHOE DIMENSIONS AND PERFORMANCE	Extendible Stick Retracted 4872 mm (16'0")		Extendible Stick Extended 4872 mm (16'0")	
	13) Digging depth, manufacturers maximum	5196 mm	17'1"	6164 mm
14) Digging depth, 610 mm (2'0") flat bottom	4589 mm	15'1"	5611 mm	18'5"
15) Reach from swing pivot at ground line	6127 mm	20'1"	7078 mm	23'3"
Loading height	4579 mm	15'0"	5309 mm	17'5"
16) Loading reach	1535 mm	5'0"	2289 mm	7'6"
Swing arc	180°		180°	
Bucket rotation	205°		205°	
17) Stabilizer width	2352 mm	7'9"	2352 mm	7'9"
Bucket dig force	63.4 kN	14,260 lbf	63.4 kN	14,260 lbf
Stick dig force	47.3 kN	10,633 lbf	35.2 kN	7913 lbf
Total side shift travel (Standard frame)	1258 mm	4'2"	1258 mm	4'2"
Total side shift travel (Narrow frame)	1096 mm	3'7"	1096 mm	3'7"

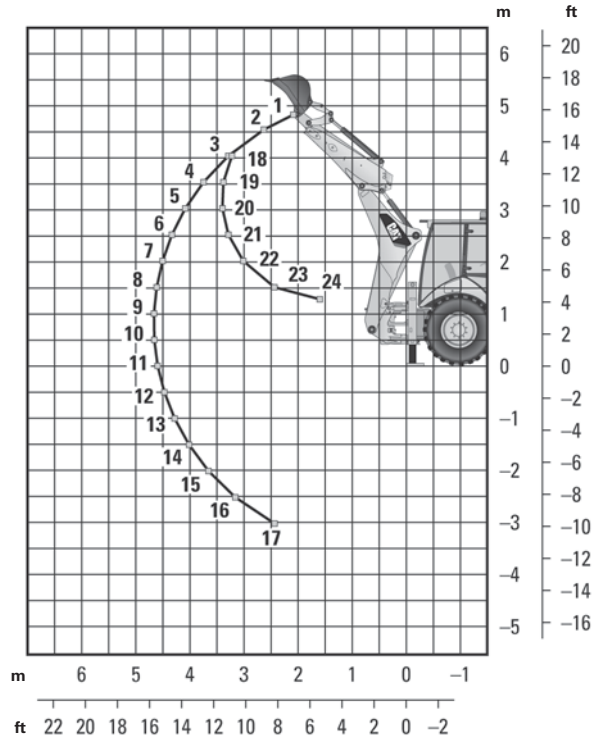

Standard Stick

Boom Lifting

1	1596 kg	3511 lb
2	1781 kg	3918 lb
3	1857 kg	4086 lb
4	1853 kg	4077 lb
5	1824 kg	4012 lb
6	1784 kg	3926 lb
7	1742 kg	3832 lb
8	1699 kg	3738 lb
9	1657 kg	3646 lb
10	1618 kg	3559 lb
11	1581 kg	3479 lb
12	1548 kg	3405 lb
13	1518 kg	3340 lb
14	1494 kg	3287 lb
15	1478 kg	3251 lb
16	1477 kg	3249 lb
17	1521 kg	3346 lb

Stick Lifting

18	2599 kg	5717 lb
19	2594 kg	5706 lb
20	2572 kg	5659 lb
21	2678 kg	5892 lb
22	2981 kg	6558 lb
23	3908 kg	8598 lb
24	5795 kg	12,750 lb

Lift Capacities are over-end values. Machine equipped with AWD, standard cab, 1.0 m³ (1.31 yd³) multi-purpose bucket, and no counterweight. Extendible stick includes 115 kg (225 lb) counterweight.

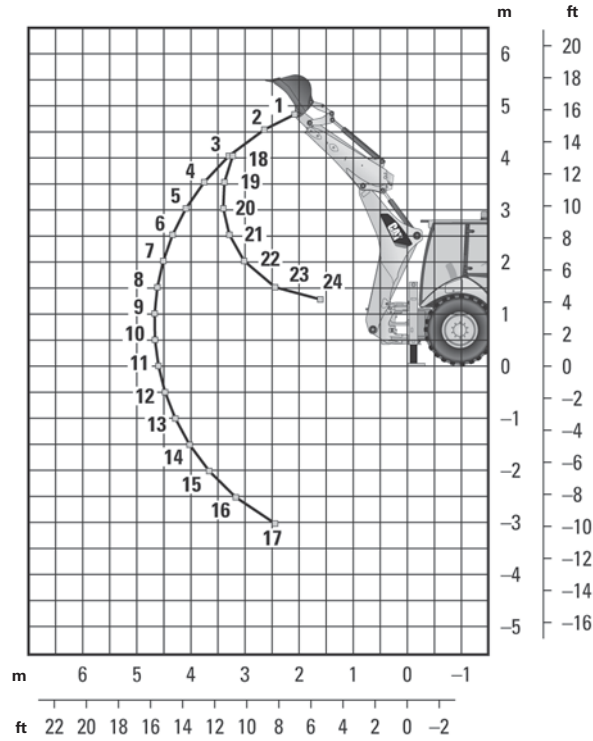

Extendible Stick Retracted – 4264 mm (14'0")

Boom Lifting

1	1514 kg	3330 lb
2	1676 kg	3688 lb
3	1732 kg	3811 lb
4	1717 kg	3778 lb
5	1681 kg	3697 lb
6	1636 kg	3599 lb
7	1589 kg	3495 lb
8	1542 kg	3392 lb
9	1496 kg	3292 lb
10	1453 kg	3197 lb
11	1413 kg	3108 lb
12	1375 kg	3026 lb
13	1342 kg	2951 lb
14	1312 kg	2886 lb
15	1289 kg	2835 lb
16	1277 kg	2809 lb
17	1298 kg	2855 lb

Stick Lifting

18	2546 kg	5601 lb
19	2467 kg	5428 lb
20	2443 kg	5375 lb
21	2544 kg	5596 lb
22	2836 kg	6240 lb
23	3735 kg	8218 lb
24	5740 kg	12,629 lb

Lift Capacities are over-end values. Machine equipped with AWD, standard cab, 1.0 m³ (1.31 yd³) multi-purpose bucket, and no counterweight. Extendible stick includes 115 kg (225 lb) counterweight.

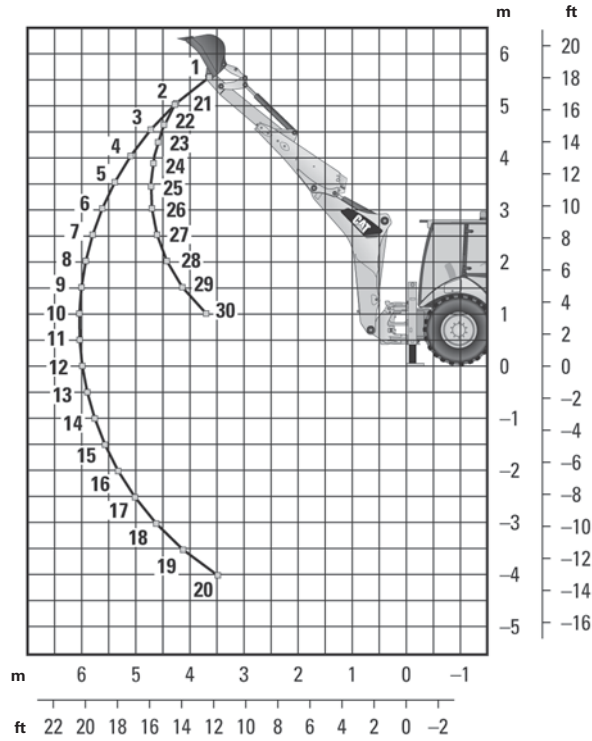

Extendible Stick Extended – 4264 mm (14'0")

Boom Lifting

1	904 kg	1989 lb
2	1092 kg	2403 lb
3	1193 kg	2624 lb
4	1236 kg	2719 lb
5	1252 kg	2754 lb
6	1253 kg	2757 lb
7	1247 kg	2743 lb
8	1235 kg	2718 lb
9	1221 kg	2687 lb
10	1206 kg	2654 lb
11	1191 kg	2620 lb
12	1176 kg	2588 lb
13	1163 kg	2558 lb
14	1151 kg	2533 lb
15	1143 kg	2514 lb
16	1139 kg	2505 lb
17	1142 kg	2511 lb
18	1157 kg	2546 lb
19	1200 kg	2641 lb
20	1340 kg	2948 lb

Stick Lifting

21	1371 kg	3016 lb
22	1634 kg	3595 lb
23	1760 kg	3872 lb
24	1751 kg	3852 lb
25	1785 kg	3926 lb
26	1870 kg	4114 lb
27	2033 kg	4473 lb
28	2352 kg	5175 lb
29	3199 kg	7037 lb
30	6409 kg	14,100 lb

Lift Capacities are over-end values. Machine equipped with AWD, standard cab, 1.0 m³ (1.31 yd³) multi-purpose bucket, and no counterweight. Extendible stick includes 115 kg (225 lb) counterweight.

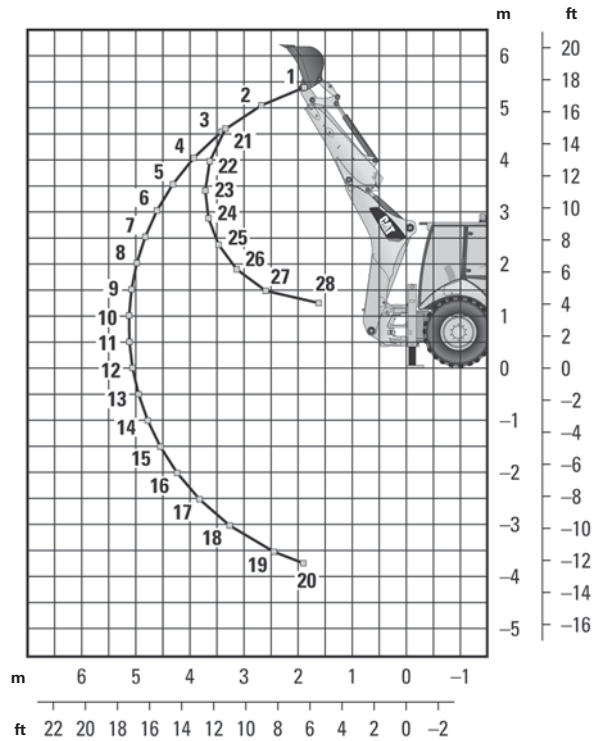

Extendible Stick Retracted – 4872 mm (16'0")

Boom Lifting

1	1660 kg	3651 lb
2	1997 kg	4394 lb
3	2079 kg	4574 lb
4	2068 kg	4549 lb
5	1996 kg	4391 lb
6	1833 kg	4033 lb
7	1721 kg	3787 lb
8	1644 kg	3617 lb
9	1593 kg	3505 lb
10	1565 kg	3442 lb
11	1556 kg	3423 lb
12	1567 kg	3448 lb
13	1601 kg	3521 lb
14	1602 kg	3523 lb
15	1568 kg	3450 lb
16	1540 kg	3387 lb
17	1519 kg	3342 lb
18	1514 kg	3330 lb
19	1556 kg	3424 lb
20	1638 kg	3604 lb

Stick Lifting

21	2712 kg	5967 lb
22	2488 kg	5473 lb
23	2427 kg	5340 lb
24	2461 kg	5414 lb
25	2591 kg	5700 lb
26	2864 kg	6300 lb
27	3442 kg	7572 lb
28	5357 kg	11,785 lb

Lift Capacities are over-end values. Machine equipped with AWD, standard cab, 1.0 m³ (1.31 yd³) multi-purpose bucket, and no counterweight. Extendible stick includes 115 kg (225 lb) counterweight.

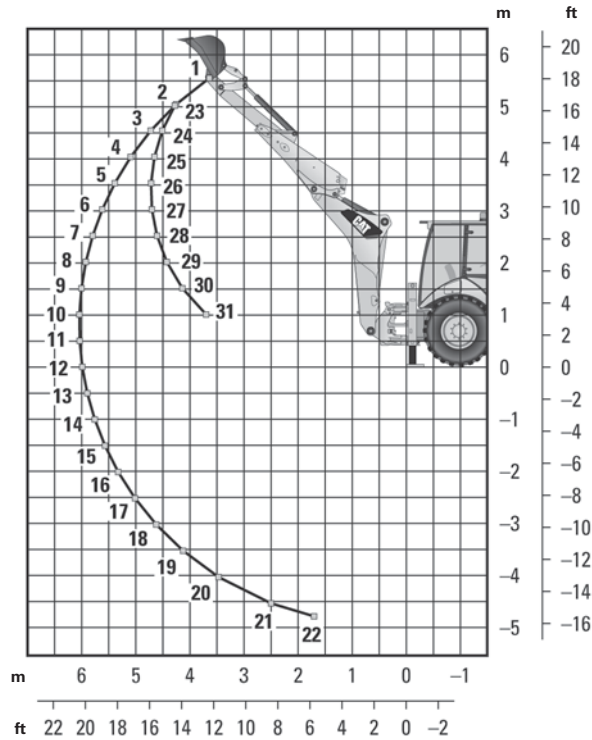

Extendible Stick Extended – 4872 mm (16'0")

Boom Lifting

1	1385 kg	3046 lb
2	1491 kg	3280 lb
3	1533 kg	3373 lb
4	1546 kg	3401 lb
5	1543 kg	3394 lb
6	1477 kg	3250 lb
7	1412 kg	3105 lb
8	1364 kg	3000 lb
9	1331 kg	2927 lb
10	1311 kg	2883 lb
11	1303 kg	2866 lb
12	1307 kg	2875 lb
13	1324 kg	2912 lb
14	1355 kg	2981 lb
15	1365 kg	3002 lb
16	1354 kg	2980 lb
17	1350 kg	2969 lb
18	1353 kg	2977 lb
19	1371 kg	3016 lb
20	1422 kg	3127 lb
21	1592 kg	3503 lb
22	1949 kg	4288 lb

Stick Lifting

23	1664 kg	3661 lb
24	1921 kg	4225 lb
25	1918 kg	4220 lb
26	1889 kg	4157 lb
27	1894 kg	4167 lb
28	1933 kg	4253 lb
29	2015 kg	4433 lb
30	2160 kg	4752 lb
31	2424 kg	5333 lb

Lift Capacities are over-end values. Machine equipped with AWD, standard cab, 1.0 m³ (1.31 yd³) multi-purpose bucket, and no counterweight. Extendible stick includes 115 kg (225 lb) counterweight.

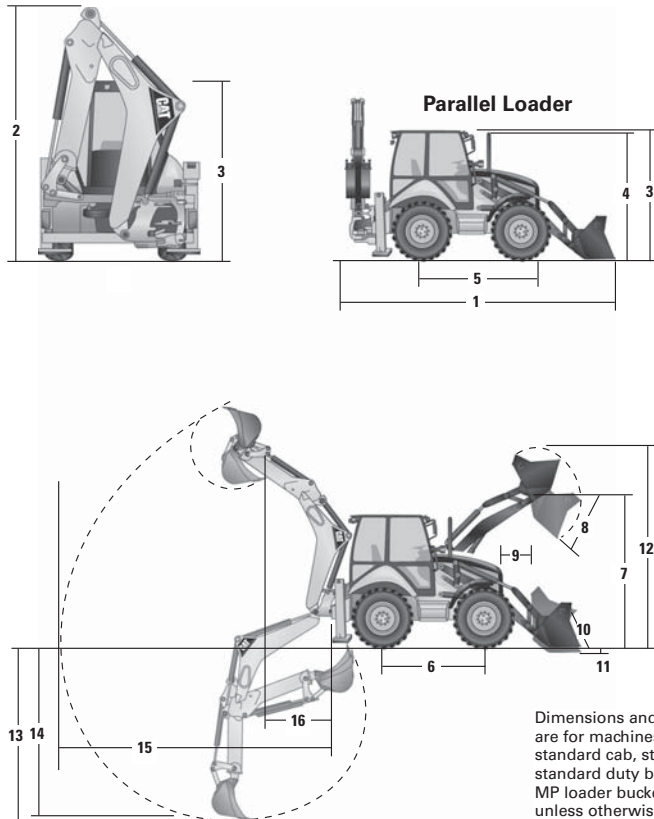

Dimensions and performance specifications shown are for machines equipped with 440/80R24 tires, standard cab, standard stick with 610 mm (24 in) standard duty bucket, and 1.15 m³ (1.5 yd³) MP loader bucket and standard equipment unless otherwise specified.

MACHINE DIMENSIONS	General Purpose 1.15 m ³ (1.5 yd ³)		Multi Purpose 1.15 m ³ (1.5 yd ³)		Multi Purpose with Forks 1.15 m ³ (1.5 yd ³)	
	mm	ft"	mm	ft"	mm	ft"
1) Overall length (loader on ground)	7574 mm	24'10"	7553 mm	24'9"	7533 mm	24'9"
Overall transport length	5921 mm	19'5"	5900 mm	19'4"	5900 mm	19'4"
2) Overall transport height S-Stick	3780 mm	12'5"	3780 mm	12'5"	3780 mm	12'5"
Overall transport height E-Stick	3769 mm	12'4"	3769 mm	12'4"	3769 mm	12'4"
Overall width	2322 mm	7'7"	2322 mm	7'7"	2322 mm	7'7"
3) Height to top of cab/canopy	2889 mm	9'6"	2889 mm	9'6"	2889 mm	9'6"
4) Height to top of exhaust stack	2754 mm	9'0"	2754 mm	9'0"	2754 mm	9'0"
Height to loader hinge pin (transport)	365 mm	1'2"	362 mm	1'2"	369 mm	1'3"
Ground clearance (stabilizer feet)	395 mm	1'4"	395 mm	1'4"	395 mm	1'4"
Ground clearance (LH step)	300 mm	1'0"	300 mm	1'0"	300 mm	1'0"
Ground clearance (AWD guard)	353 mm	1'2"	353 mm	1'2"	353 mm	1'2"
5) Rear axle centerline to front grill	2795 mm	9'2"	2795 mm	9'2"	2795 mm	9'2"
Front wheel tread gauge	1826 mm	6'0"	1826 mm	6'0"	1826 mm	6'0"
Rear wheel tread gauge	1707 mm	5'7"	1707 mm	5'7"	1707 mm	5'7"
6) Wheelbase (AWD)	2235 mm	7'4"	2235 mm	7'4"	2235 mm	7'4"

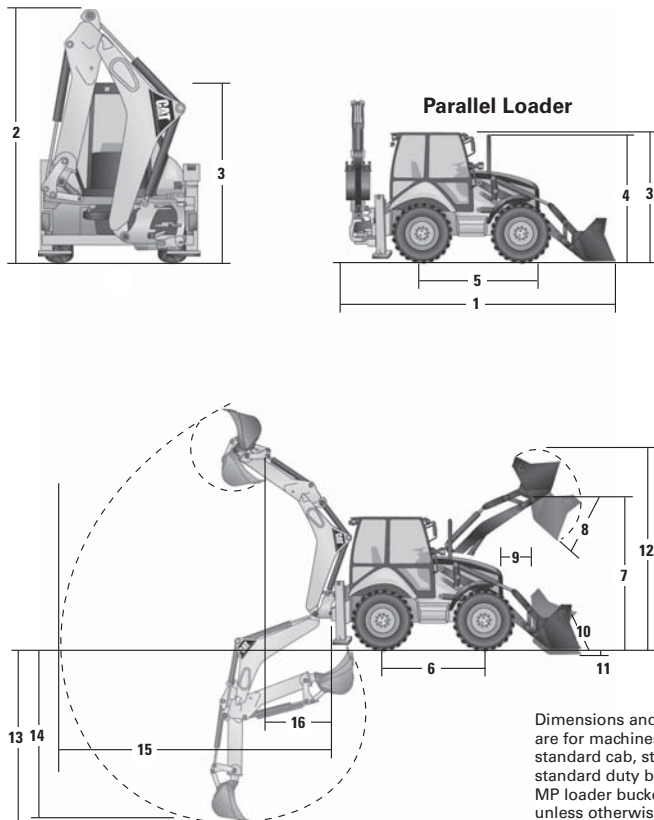

Dimensions and performance specifications shown are for machines equipped with 440/80R24 tires, standard cab, standard stick with 610 mm (24 in) standard duty bucket, and 1.15 m³ (1.5 yd³) MP loader bucket and standard equipment unless otherwise specified.

LOADER BUCKET DIMENSIONS AND PERFORMANCE	General Purpose 1.15 m ³ (1.5 yd ³)		Multi Purpose 1.15 m ³ (1.5 yd ³)		Multi Purpose with Forks 1.15 m ³ (1.5 yd ³)	
	Capacity (SAE) rated	1.15 m ³	1.5 yd ³	1.15 m ³	1.5 yd ³	1.15 m ³
Width	2434 mm	96"	2434 mm	96"	2434 mm	96"
Lift capacity at maximum height	4661 kg	10,276 lb	4329 kg	9544 lb	4150 kg	9150 lb
Lift breakout force	61.3 kN	13,770 lbf	58.5 kN	13,156 lbf	56.6 kN	12,715 lbf
Tilt breakout force	63.4 kN	14,252 lbf	63.6 kN	14,306 lbf	62.3 kN	14,008 lbf
7) Maximum hinge pin height	3518 mm	11'7"	3518 mm	11'7"	3518 mm	11'7"
8) Dump angle at full height		45°		45°		45°
Dump height at maximum angle	2745 mm	9'0"	2760 mm	9'1"	2760 mm	9'1"
9) Dump reach at maximum angle	923 mm	3'0"	908 mm	3'0"	908 mm	3'0"
10) Maximum bucket rollback at ground level		44°		44°		44°
11) Digging depth	154 mm	6"	154 mm	6"	154 mm	6"
Maximum grading angle		109°		110°		110°
Width of dozer cutting edge		N/A	2434 mm	8'0"	2434 mm	8'0"
Grill to bucket cutting edge, carry position	1494 mm	4'11"	1479 mm	4'10"	1482 mm	4'10"
12) Maximum operating height	4386 mm	14'5"	4463 mm	14'8"	4341 mm	14'3"
Jaw opening maximum		N/A	790 mm	2'7"	790 mm	2'7"
Bucket jaw clamping force		N/A	62.2 kN	13,988 lbf	62.2 kN	13,988 lbf
Weight (does not include teeth or forks)	438 kg	966 lb	752 kg	1658 lb	927 kg	2044 lb

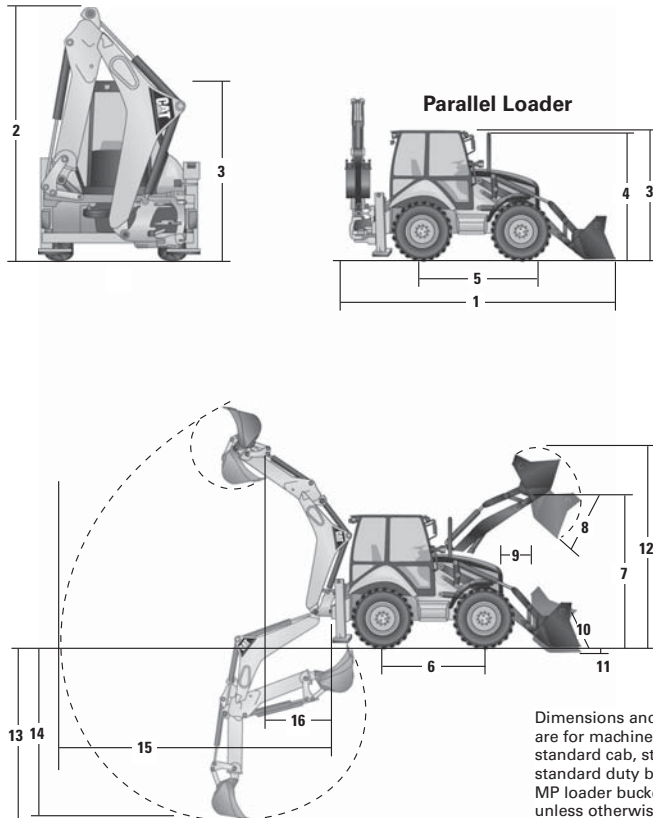

Dimensions and performance specifications shown are for machines equipped with 440/80R24 tires, standard cab, standard stick with 610 mm (24 in) standard duty bucket, and 1.15 m³ (1.5 yd³) MP loader bucket and standard equipment unless otherwise specified.

BACKHOE DIMENSIONS AND PERFORMANCE	Standard Stick		Extendible Stick Retracted 4264 mm (14'0")		Extendible Stick Extended 4264 mm (14'0")	
	13) Digging depth, manufacturers maximum	4827 mm	15'10"	4832 mm	15'10"	5748 mm
14) Digging depth, 610 mm (2'0") flat bottom	4306 mm	14'2"	4309 mm	14'2"	5296 mm	17'5"
15) Reach from swing pivot at ground line	5655 mm	18'7"	5660 mm	18'7"	6586 mm	21'7"
Loading height	3909 mm	12'10"	3920 mm	12'10"	4487 mm	14'9"
16) Loading reach	1808 mm	5'11"	1758 mm	5'9"	2642 mm	8'8"
Swing arc	180°		180°		180°	
Bucket rotation	205°		205°		205°	
Bucket dig force	63.4 kN	14,260 lbf	63.4 kN	14,254 lbf	63.4 kN	14,254 lbf
Stick dig force	36.1 kN	8115 lbf	36.8 kN	8265 lbf	26.9 kN	6041 lbf
Total side shift travel	1258 mm	4'2"	1258 mm	4'2"	1258 mm	4'2"

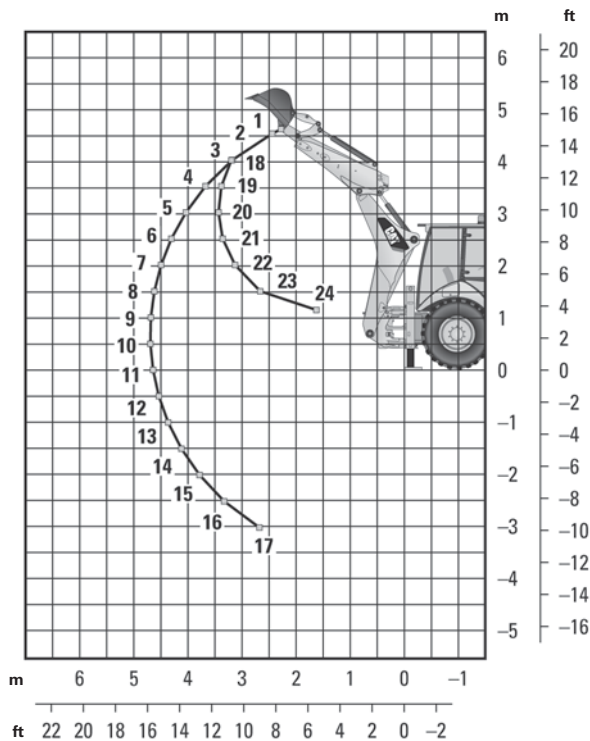

Standard Stick

Boom Lifting

1	1155 kg	2541 lb
2	1281 kg	2818 lb
3	1410 kg	3103 lb
4	1439 kg	3167 lb
5	1435 kg	3157 lb
6	1416 kg	3115 lb
7	1391 kg	3060 lb
8	1363 kg	2999 lb
9	1335 kg	2937 lb
10	1308 kg	2878 lb
11	1282 kg	2821 lb
12	1260 kg	2771 lb
13	1240 kg	2728 lb
14	1226 kg	2697 lb
15	1220 kg	2683 lb
16	1229 kg	2705 lb
17	1286 kg	2830 lb

Stick Lifting

18	2111 kg	4644 lb
19	1985 kg	4367 lb
20	1961 kg	4315 lb
21	2035 kg	4477 lb
22	2255 kg	4961 lb
23	2906 kg	6394 lb
24	5317 kg	11,696 lb

Lift Capacities are over-end values. Machine equipped with AWD, standard cab, 1.15 m³ (1.5 yd³) multi-purpose bucket, 440/80R24 tires and 0 kg (0 lb) counterweight.

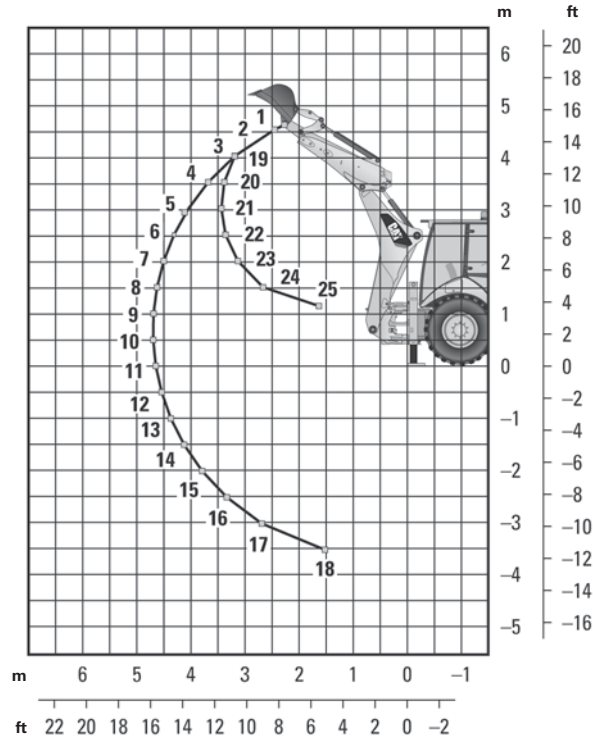

Extendible Stick Retracted – 4264 mm (14'0")

Boom Lifting

1	1062 kg	2337 lb
2	1179 kg	2593 lb
3	1286 kg	2830 lb
4	1304 kg	2870 lb
5	1293 kg	2844 lb
6	1268 kg	2790 lb
7	1238 kg	2725 lb
8	1207 kg	2655 lb
9	1175 kg	2585 lb
10	1144 kg	2517 lb
11	1115 kg	2453 lb
12	1088 kg	2394 lb
13	1064 kg	2342 lb
14	1045 kg	2299 lb
15	1032 kg	2270 lb
16	1031 kg	2269 lb
17	1067 kg	2347 lb
18	1401 kg	3083 lb

Stick Lifting

19	1991 kg	4380 lb
20	1859 kg	4089 lb
21	1833 kg	4032 lb
22	1902 kg	4183 lb
23	2112 kg	4646 lb
24	2739 kg	6025 lb
25	5041 kg	11,090 lb

Lift Capacities are over-end values. Machine equipped with AWD, standard cab, 1.15 m³ (1.5 yd³) multi-purpose bucket, 440/80R24 tires and 0 kg (0 lb) counterweight.

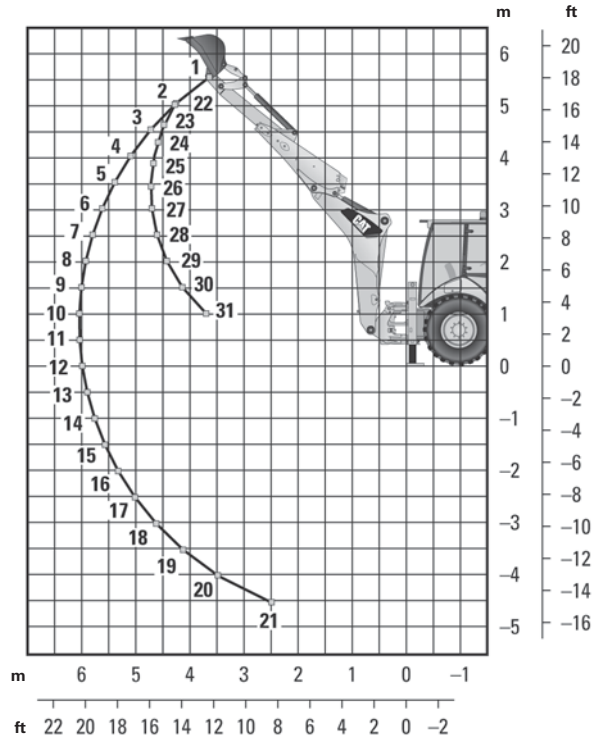

Extendible Stick Extended – 4264 mm (14'0")

Boom Lifting

1	629 kg	1383 lb
2	740 kg	1628 lb
3	855 kg	1881 lb
4	910 kg	2003 lb
5	937 kg	2062 lb
6	949 kg	2088 lb
7	951 kg	2093 lb
8	948 kg	2086 lb
9	942 kg	2072 lb
10	933 kg	2053 lb
11	924 kg	2034 lb
12	915 kg	2014 lb
13	907 kg	1996 lb
14	901 kg	1981 lb
15	896 kg	1972 lb
16	896 kg	1971 lb
17	902 kg	1985 lb
18	920 kg	2023 lb
19	962 kg	2117 lb
20	1088 kg	2395 lb
21	2846 kg	6260 lb

Stick Lifting

22	1109 kg	2440 lb
23	1315 kg	2893 lb
24	1308 kg	2877 lb
25	1298 kg	2855 lb
26	1321 kg	2906 lb
27	1383 kg	3043 lb
28	1503 kg	3307 lb
29	1737 kg	3821 lb
30	2333 kg	5132 lb
31	6090 kg	13,397 lb

Lift Capacities are over-end values. Machine equipped with AWD, standard cab, 1.15 m³ (1.5 yd³) multi-purpose bucket, 440/80R24 tires and 0 kg (0 lb) counterweight.

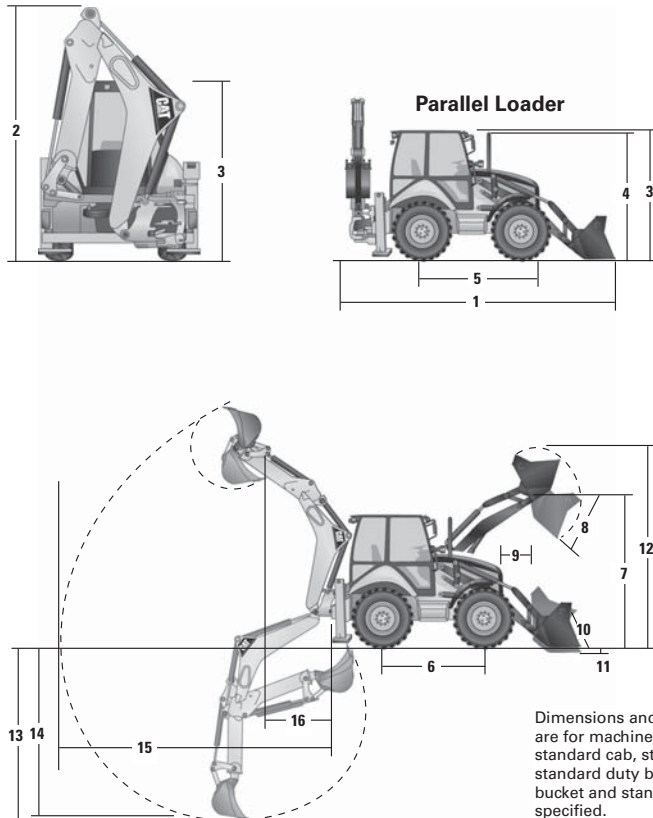

Dimensions and performance specifications shown are for machines equipped with 440/80R28 tires, standard cab, standard stick with 610 mm (24 in) standard duty bucket, and 1.3 m³ (1.7 yd³) MP loader bucket and standard equipment unless otherwise specified.

MACHINE DIMENSIONS	Parallel Loader					
	General Purpose 1.3 m ³ (1.7 yd ³)		Multi Purpose 1.3 m ³ (1.7 yd ³)		Multi Purpose with Forks 1.3 m ³ (1.7 yd ³)	
1) Overall length (loader on ground)	7548 mm	24'9"	7409 mm	24'4"	7409 mm	24'4"
Overall transport length	5892 mm	19'4"	5751 mm	18'10"	5751 mm	18'10"
2) Overall transport height S-Stick	3829 mm	12'7"	3829 mm	12'7"	3829 mm	12'7"
Overall transport height E-Stick	3818 mm	12'6"	3818 mm	12'6"	3818 mm	12'6"
Overall transport height E-Stick 4872 mm (16'0")	4008 mm	13'2"	4008 mm	13'2"	4008 mm	13'2"
Overall width	2322 mm	7'7"	2322 mm	7'7"	2322 mm	7'7"
3) Height to top of cab/canopy	2897 mm	9'6"	2897 mm	9'6"	2897 mm	9'6"
4) Height to top of exhaust stack	2754 mm	9'0"	2754 mm	9'0"	2754 mm	9'0"
Height to loader hinge pin (transport)	365 mm	1'2"	362 mm	1'2"	369 mm	1'3"
Ground clearance (stabilizer feet)	444 mm	2'0"	444 mm	2'0"	444 mm	2'0"
Ground clearance (LH step)	349 mm	1'4"	349 mm	1'4"	349 mm	1'4"
Ground clearance (AWD guard)	402 mm	1'7"	402 mm	1'7"	402 mm	1'7"
5) Rear axle centerline to front grill	2795 mm	9'2"	2795 mm	9'2"	2795 mm	9'2"
Front wheel tread gauge	1826 mm	6'0"	1826 mm	6'0"	1826 mm	6'0"
Rear wheel tread gauge	1707 mm	5'7"	1707 mm	5'7"	1707 mm	5'7"
6) Wheelbase (AWD)	2235 mm	7'4"	2235 mm	7'4"	2235 mm	7'4"

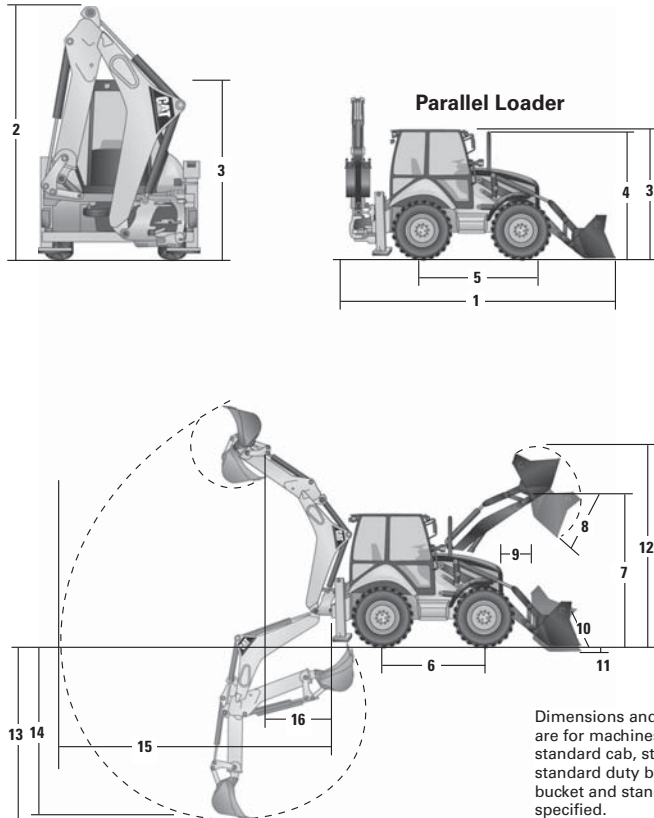

Dimensions and performance specifications shown are for machines equipped with 440/80R28 tires, standard cab, standard stick with 610 mm (24 in) standard duty bucket, and 1.3 m³ (1.7 yd³) MP loader bucket and standard equipment unless otherwise specified.

MACHINE DIMENSIONS	Parallel Loader with Quick Coupler			
	General Purpose 1.3 m ³ (1.7 yd ³)		Multi Purpose 1.3 m ³ (1.7 yd ³)	
1) Overall length (loader on ground)	7621 mm	25'0"	7665 mm	25'2"
Overall transport length	5965 mm	19'7"	6010 mm	19'9"
2) Overall transport height S-Stick	3829 mm	12'7"	3829 mm	12'7"
Overall transport height E-Stick	3818 mm	12'6"	3818 mm	12'6"
Overall transport height E-Stick 4872 mm (16'0")	4008 mm	13'2"	4008 mm	13'2"
Overall width	2322 mm	7'7"	2322 mm	7'7"
3) Height to top of cab/canopy	2897 mm	9'6"	2897 mm	9'6"
4) Height to top of exhaust stack	2754 mm	9'0"	2754 mm	9'0"
Height to loader hinge pin (transport)	317 mm	1'0"	319 mm	1'1"
Ground clearance (stabilizer feet)	444 mm	2'0"	444 mm	2'0"
Ground clearance (LH step)	349 mm	1'4"	349 mm	1'4"
Ground clearance (AWD guard)	402 mm	1'7"	402 mm	1'7"
5) Rear axle centerline to front grill	2795 mm	9'2"	2795 mm	9'2"
Front wheel tread gauge	1826 mm	6'0"	1826 mm	6'0"
Rear wheel tread gauge	1707 mm	5'7"	1707 mm	5'7"
6) Wheelbase (2WD/AWD)	2235 mm	7'4"	2235 mm	7'4"

LOADER BUCKET DIMENSIONS AND PERFORMANCE	Parallel Loader					
	General Purpose 1.3 m ³ (1.7 yd ³)		Multi Purpose 1.3 m ³ (1.7 yd ³)		Multi Purpose with Forks 1.3 m ³ (1.7 yd ³)	
Capacity (SAE) rated	1.3 m ³	1.7 yd ³	1.3 m ³	1.7 yd ³	1.3 m ³	1.7 yd ³
Width	2434 mm	96"	2434 mm	96"	2434 mm	96"
Lift capacity at maximum height	4661 kg	10,276 lb	4329 kg	9544 lb	4150 kg	9150 lb
Lift breakout force	61.6 kN	13,849 lbf	58.9 kN	13,232 lbf	56.9 kN	12,790 lbf
Tilt breakout force	63.3 kN	14,235 lbf	63.6 kN	14,289 lbf	62.2 kN	13,990 lbf
7) Maximum hinge pin height	3567 mm	11'8"	3567 mm	11'8"	3567 mm	11'8"
8) Dump angle at full height		45°		45°		45°
Dump height at maximum angle	2794 mm	9'2"	2809 mm	9'3"	2809 mm	9'3"
9) Dump reach at maximum angle	923 mm	3'0"	908 mm	3'0"	908 mm	3'0"
10) Maximum bucket rollback at ground level		44°		44°		44°
11) Digging depth	105 mm	4"	105 mm	4"	105 mm	4"
Maximum grading angle		109°		110°		110°
Width of dozer cutting edge		N/A	2434 mm	8'0"	2434 mm	8'0"
Grill to bucket cutting edge, carry position	1480 mm	4'10"	1464 mm	4'10"	1466 mm	4'10"
12) Maximum operating height	4435 mm	14'7"	4512 mm	14'10"	4390 mm	14'5"
Jaw opening maximum		N/A	790 mm	2'7"	790 mm	2'7"
Bucket jaw clamping force		N/A	62.2 kN	13,988 lbf	62.2 kN	13,988 lbf
Weight (does not include teeth or forks)	460 kg	1014 lb	752 kg	1658 lb	927 kg	2044 lb

LOADER BUCKET DIMENSIONS AND PERFORMANCE	Parallel Loader with Quick Coupler			
	General Purpose 1.3 m ³ (1.7 yd ³)		Multi Purpose 1.3 m ³ (1.7 yd ³)	
Capacity (SAE) rated	1.3 m ³	1.7 yd ³	1.3 m ³	1.7 yd ³
Width	2434 mm	96"	2434 mm	96"
Lift capacity at maximum height	4498 kg	9917 lb	4142 kg	9132 lb
Lift breakout force	58.8 kN	13,209 lbf	55.1 kN	12,378 lbf
Tilt breakout force	57.3 kN	12,882 lbf	52.3 kN	11,765 lbf
7) Maximum hinge pin height	3442 mm	11'4"	3442 mm	11'4"
8) Dump angle at full height		45°		45°
Dump height at maximum angle	2616 mm	8'7"	2585 mm	8'6"
9) Dump reach at maximum angle	972 mm	3'2"	1008 mm	3'4"
10) Maximum bucket rollback at ground level		46°		46°
11) Digging depth	233 mm	9"	229 mm	9"
Maximum grading angle		105°		104°
Width of dozer cutting edge		N/A		N/A
Grill to bucket cutting edge, carry position	1555 mm	5'1"	1584 mm	5'2"
12) Maximum operating height	4491 mm	14'9"	4512 mm	14'10"
Jaw opening maximum		N/A	790 mm	2'7"
Bucket jaw clamping force		N/A	62.2 kN	13,988 lbf
Weight (does not include teeth or forks)	637 kg	1404 lb	989 kg	2180 lb

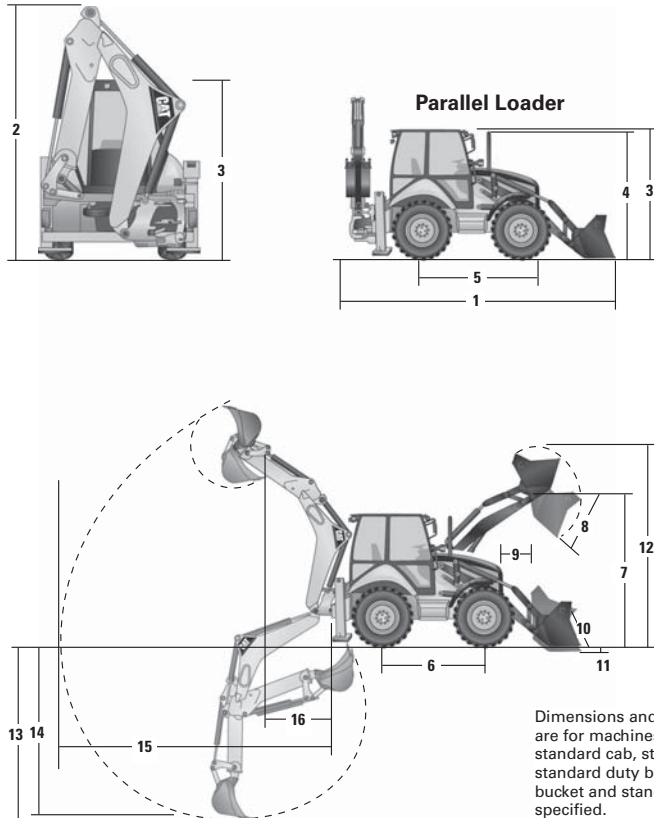

Dimensions and performance specifications shown are for machines equipped with 440/80R28 tires, standard cab, standard stick with 610 mm (24 in) standard duty bucket, and 1.3 m³ (1.7 yd³) MP loader bucket and standard equipment unless otherwise specified.

BACKHOE DIMENSIONS AND PERFORMANCE	Standard Stick		Extendible Stick Retracted 4264 mm (14'0")		Extendible Stick Extended 4264 mm (14'0")	
	13) Digging depth, manufacturers maximum	4738 mm	15'7"	4743 mm	15'7"	5660 mm
14) Digging depth, 610 mm (2'0") flat bottom	4288 mm	14'1"	4291 mm	14'1"	5278 mm	17'4"
15) Reach from swing pivot at ground line	5655 mm	18'7"	5660 mm	18'7"	6586 mm	21'7"
Loading height	3927 mm	12'11"	3938 mm	12'11"	4505 mm	14'9"
16) Loading reach	1808 mm	5'11"	1758 mm	5'9"	2642 mm	8'8"
Swing arc	180°		180°		180°	
Bucket rotation	205°		205°		205°	
Bucket dig force	63.4 kN	14,260 lbf	63.4 kN	14,254 lbf	63.4 kN	14,254 lbf
Stick dig force	42.7 kN	9600 lbf	43.5 kN	9769 lbf	31.6 kN	7112 lbf
Total side shift travel	1258 mm	4'2"	1258 mm	4'2"	1258 mm	4'2"

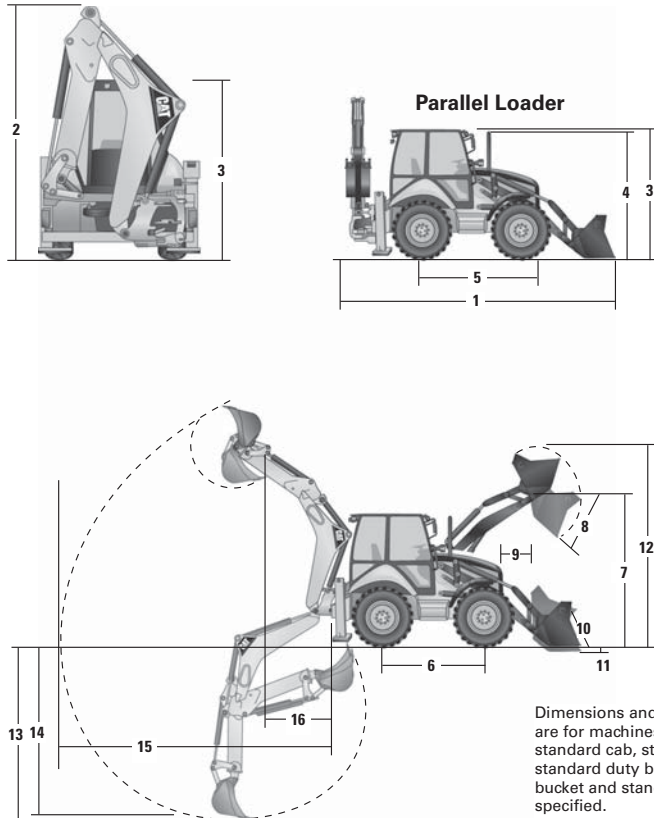

Dimensions and performance specifications shown are for machines equipped with 440/80R28 tires, standard cab, standard stick with 610 mm (24 in) standard duty bucket, and 1.3 m³ (1.7 yd³) MP loader bucket and standard equipment unless otherwise specified.

BACKHOE DIMENSIONS AND PERFORMANCE	Extendible Stick Retracted 4872 mm (16'0")		Extendible Stick Extended 4872 mm (16'0")	
	13) Digging depth, manufacturers maximum	5168 mm	16'11"	6129 mm
14) Digging depth, 610 mm (2'0") flat bottom	4654 mm	15'3"	5671 mm	18'7"
15) Reach from swing pivot at ground line	6132 mm	20'1"	7083 mm	23'3"
Loading height	4495 mm	14'9"	5192 mm	17'0"
16) Loading reach	1696 mm	5'7"	2482 mm	8'2"
Swing arc	180°		180°	
Bucket rotation	205°		205°	
Bucket dig force	63.4 kN	14,256 lbf	63.4 kN	14,256 lbf
Stick dig force	47.2 kN	10,605 lbf	35.1 kN	7887 lbf
Total side shift travel	1258 mm	4'2"	1258 mm	4'2"

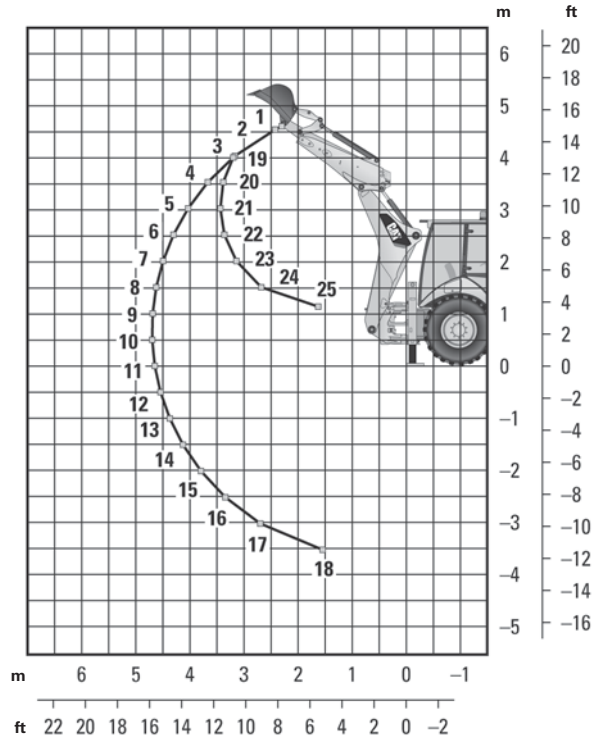

Standard Stick

Boom Lifting

1	1407 kg	3096 lb
2	1577 kg	3470 lb
3	1735 kg	3818 lb
4	1774 kg	3903 lb
5	1772 kg	3898 lb
6	1752 kg	3854 lb
7	1724 kg	3794 lb
8	1694 kg	3726 lb
9	1663 kg	3658 lb
10	1632 kg	3591 lb
11	1604 kg	3529 lb
12	1579 kg	3475 lb
13	1559 kg	3430 lb
14	1546 kg	3401 lb
15	1543 kg	3395 lb
16	1563 kg	3438 lb
17	1648 kg	3626 lb
18	2240 kg	4928 lb

Stick Lifting

19	2568 kg	5650 lb
20	2416 kg	5315 lb
21	2392 kg	5263 lb
22	2487 kg	5471 lb
23	2762 kg	6076 lb
24	3591 kg	7899 lb
25	6441 kg	14,169 lb

Lift Capacities are over-end values. Machine equipped with AWD, standard cab, 1.3 m³ (1.7 yd³) multi-purpose bucket, 440/80R28 tires and 0 kg (0 lb) counterweight.

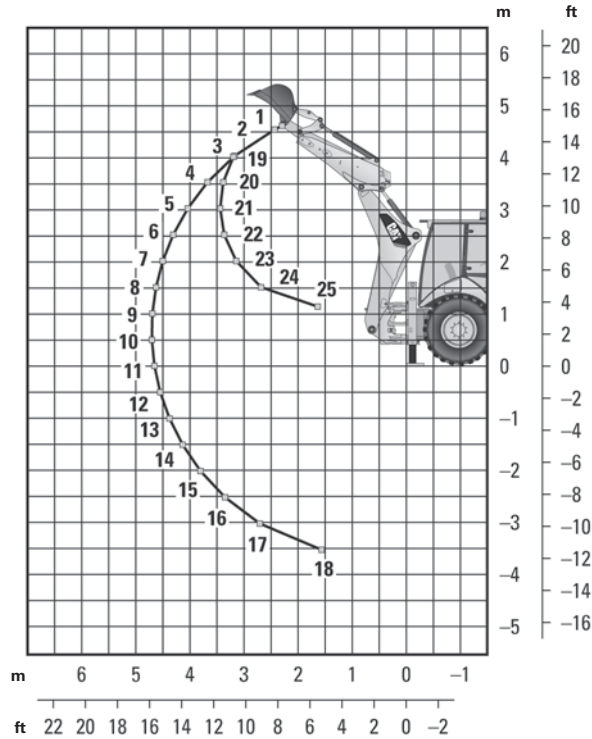

Extendible Stick Retracted – 4264 mm (14'0")

Boom Lifting

1	1315 kg	2894 lb
2	1475 kg	3246 lb
3	1612 kg	3546 lb
4	1639 kg	3606 lb
5	1629 kg	3584 lb
6	1604 kg	3529 lb
7	1572 kg	3458 lb
8	1537 kg	3381 lb
9	1502 kg	3304 lb
10	1468 kg	3230 lb
11	1436 kg	3160 lb
12	1407 kg	3096 lb
13	1383 kg	3042 lb
14	1364 kg	3000 lb
15	1354 kg	2979 lb
16	1363 kg	2998 lb
17	1425 kg	3136 lb
18	1904 kg	4189 lb

Stick Lifting

19	2442 kg	5372 lb
20	2289 kg	5037 lb
21	2263 kg	4980 lb
22	2353 kg	5176 lb
23	2618 kg	5759 lb
24	3420 kg	7524 lb
25	6156 kg	13,543 lb

Lift Capacities are over-end values. Machine equipped with AWD, standard cab, 1.3 m³ (1.7 yd³) multi-purpose bucket, 440/80R28 tires and 0 kg (0 lb) counterweight.

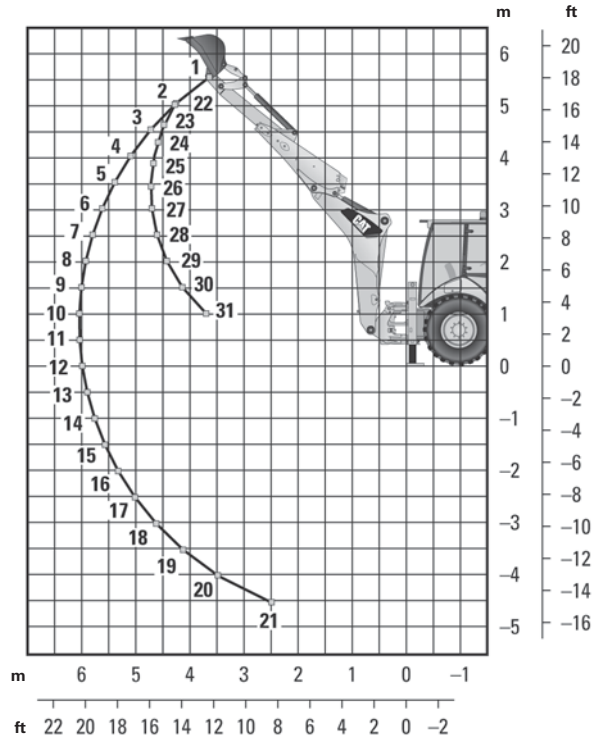

Extendible Stick Extended – 4264 mm (14'0")

Boom Lifting

1	799 kg	1757 lb
2	947 kg	2083 lb
3	1089 kg	2396 lb
4	1159 kg	2551 lb
5	1195 kg	2629 lb
6	1212 kg	2666 lb
7	1217 kg	2678 lb
8	1216 kg	2675 lb
9	1211 kg	2663 lb
10	1203 kg	2647 lb
11	1195 kg	2628 lb
12	1186 kg	2610 lb
13	1179 kg	2594 lb
14	1174 kg	2583 lb
15	1172 kg	2579 lb
16	1176 kg	2586 lb
17	1188 kg	2613 lb
18	1216 kg	2674 lb
19	1278 kg	2811 lb
20	1459 kg	3209 lb
21	3786 kg	8329 lb

Stick Lifting

22	1371 kg	3016 lb
23	1627 kg	3579 lb
24	1627 kg	3580 lb
25	1618 kg	3559 lb
26	1648 kg	3625 lb
27	1725 kg	3796 lb
28	1875 kg	4124 lb
29	2166 kg	4765 lb
30	2924 kg	6433 lb
31	7224 kg	15,894 lb

Lift Capacities are over-end values. Machine equipped with AWD, standard cab, 1.3 m³ (1.7 yd³) multi-purpose bucket, 440/80R28 tires and 0 kg (0 lb) counterweight.

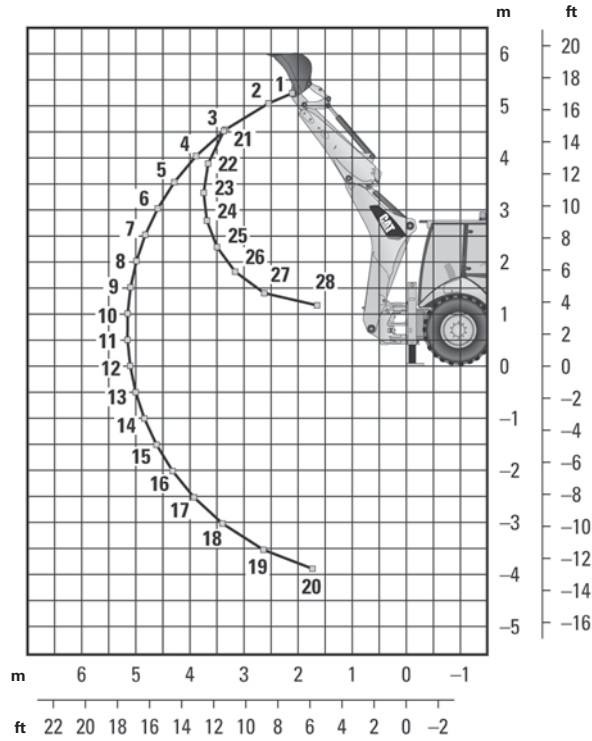

Extendible Stick Retracted – 4872 mm (16'0")

Boom Lifting

1	1381 kg	3039 lb
2	1729 kg	3804 lb
3	1920 kg	4224 lb
4	1963 kg	4318 lb
5	1957 kg	4306 lb
6	1932 kg	4250 lb
7	1897 kg	4174 lb
8	1859 kg	4089 lb
9	1819 kg	4002 lb
10	1780 kg	3916 lb
11	1742 kg	3833 lb
12	1707 kg	3756 lb
13	1675 kg	3686 lb
14	1647 kg	3624 lb
15	1624 kg	3573 lb
16	1608 kg	3538 lb
17	1605 kg	3530 lb
18	1625 kg	3576 lb
19	1726 kg	3797 lb
20	1983 kg	4363 lb

Stick Lifting

21	2742 kg	6032 lb
22	2679 kg	5895 lb
23	2598 kg	5716 lb
24	2643 kg	5814 lb
25	2818 kg	6199 lb
26	3200 kg	7040 lb
27	4079 kg	8974 lb
28	6309 kg	13,881 lb

Lift Capacities are over-end values. Machine equipped with AWD, standard cab, 1.3 m³ (1.7 yd³) multi-purpose bucket, 440/80R28 tires and 0 kg (0 lb) counterweight.

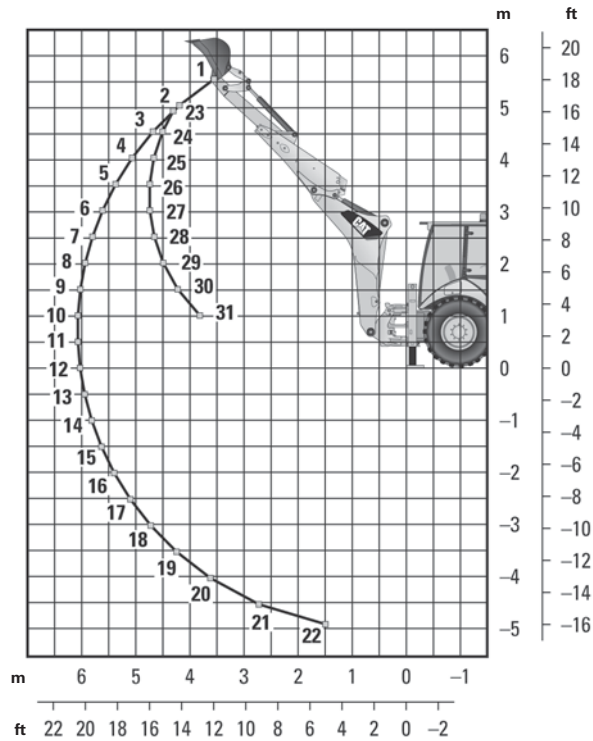

Extendible Stick Extended – 4872 mm (16'0")

Boom Lifting

1	1203 kg	2646 lb
2	1362 kg	2997 lb
3	1438 kg	3164 lb
4	1474 kg	3244 lb
5	1490 kg	3277 lb
6	1492 kg	3283 lb
7	1488 kg	3273 lb
8	1478 kg	3252 lb
9	1466 kg	3226 lb
10	1453 kg	3197 lb
11	1440 kg	3168 lb
12	1427 kg	3139 lb
13	1415 kg	3113 lb
14	1406 kg	3092 lb
15	1399 kg	3078 lb
16	1396 kg	3072 lb
17	1401 kg	3081 lb
18	1415 kg	3113 lb
19	1448 kg	3185 lb
20	1523 kg	3350 lb
21	1748 kg	3845 lb
22	2539 kg	5586 lb

Stick Lifting

23	1664 kg	3661 lb
24	1914 kg	4211 lb
25	1953 kg	4297 lb
26	1916 kg	4215 lb
27	1920 kg	4224 lb
28	1966 kg	4325 lb
29	2064 kg	4540 lb
30	2242 kg	4932 lb
31	2577 kg	5669 lb

Lift Capacities are over-end values. Machine equipped with AWD, standard cab, 1.3 m³ (1.7 yd³) multi-purpose bucket, 440/80R28 tires and 0 kg (0 lb) counterweight.

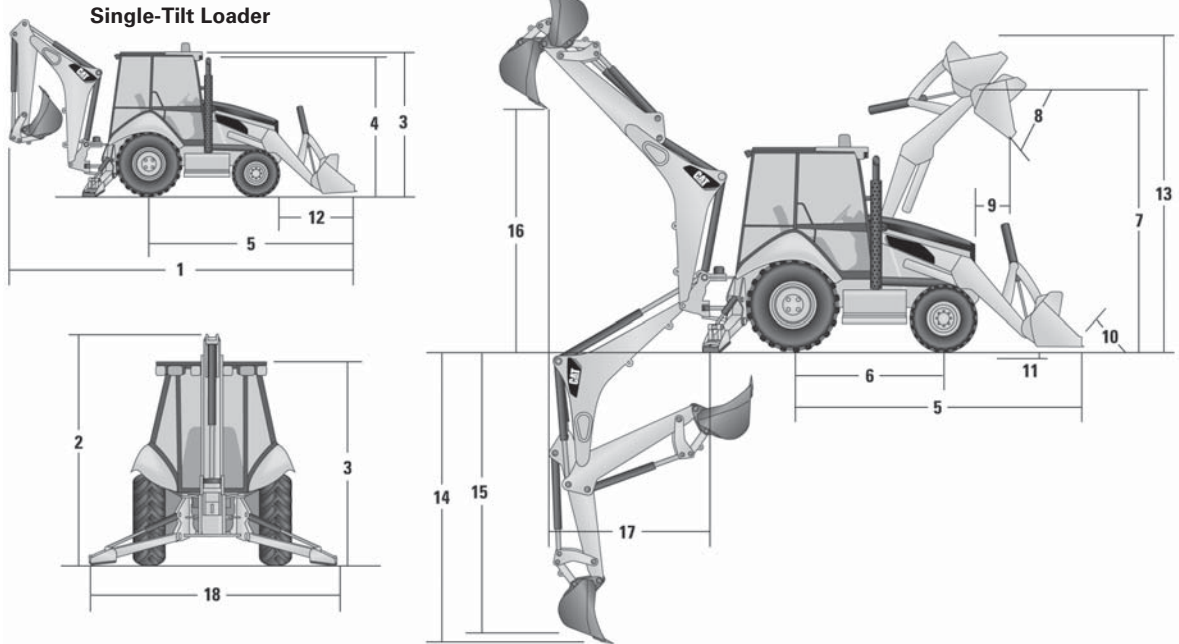

Dimensions and performance specifications shown are for machines equipped with 15-19.5 (12 PR) front tires, 21L-24 (18 PR) rear tires, ROPS canopy, standard stick with 610 mm (24 in) heavy-duty bucket, and 1.3 m³ (1.7 yd³) loader bucket and standard equipment unless otherwise specified.

MACHINE DIMENSIONS	Single-Tilt Loader					
	General Purpose 1.3 m ³ (1.7 yd ³)		Multi Purpose 1.15 m ³ (1.5 yd ³)		Multi Purpose with Forks 1.15 m ³ (1.5 yd ³)	
1) Overall length, loader on ground, standard stick	7913 mm	26'0"	7786 mm	25'7"	7786 mm	25'7"
Overall length, loader on ground, extendible stick	7913 mm	26'0"	7786 mm	25'7"	7786 mm	25'7"
Overall transport length, standard stick	7916 mm	26'0"	7826 mm	25'8"	7826 mm	25'8"
Overall transport length, extendible stick	7916 mm	26'0"	7826 mm	25'8"	7826 mm	25'8"
2) Overall transport height, standard stick	4143 mm	13'7"	4143 mm	13'7"	4143 mm	13'7"
Overall transport height, extendible stick	4159 mm	13'8"	4159 mm	13'8"	4159 mm	13'8"
Overall width	2436 mm	8'0"	2436 mm	8'0"	2436 mm	8'0"
3) Height to top of cab/canopy	2874 mm	9'5"	2874 mm	9'5"	2874 mm	9'5"
4) Height to top of exhaust stack	2845 mm	9'4"	2845 mm	9'4"	2845 mm	9'4"
Rear axle centerline to front grill	2832 mm	9'4"	2832 mm	9'4"	2832 mm	9'4"
Height to loader hinge pin (transport)	469 mm	1'6"	481 mm	1'7"	481 mm	1'7"
Ground clearance (minimum)	322 mm	1'1"	322 mm	1'1"	322 mm	1'1"
5) Rear axle to loader bucket on ground	4494 mm	14'9"	4367 mm	14'4"	4367 mm	14'4"
Front wheel tread gauge	2016 mm	6'7"	2016 mm	6'7"	2016 mm	6'7"
Rear wheel tread gauge	1814 mm	5'11"	1814 mm	5'11"	1814 mm	5'11"
6) Wheelbase	2200 mm	7'3"	2200 mm	7'3"	2200 mm	7'3"

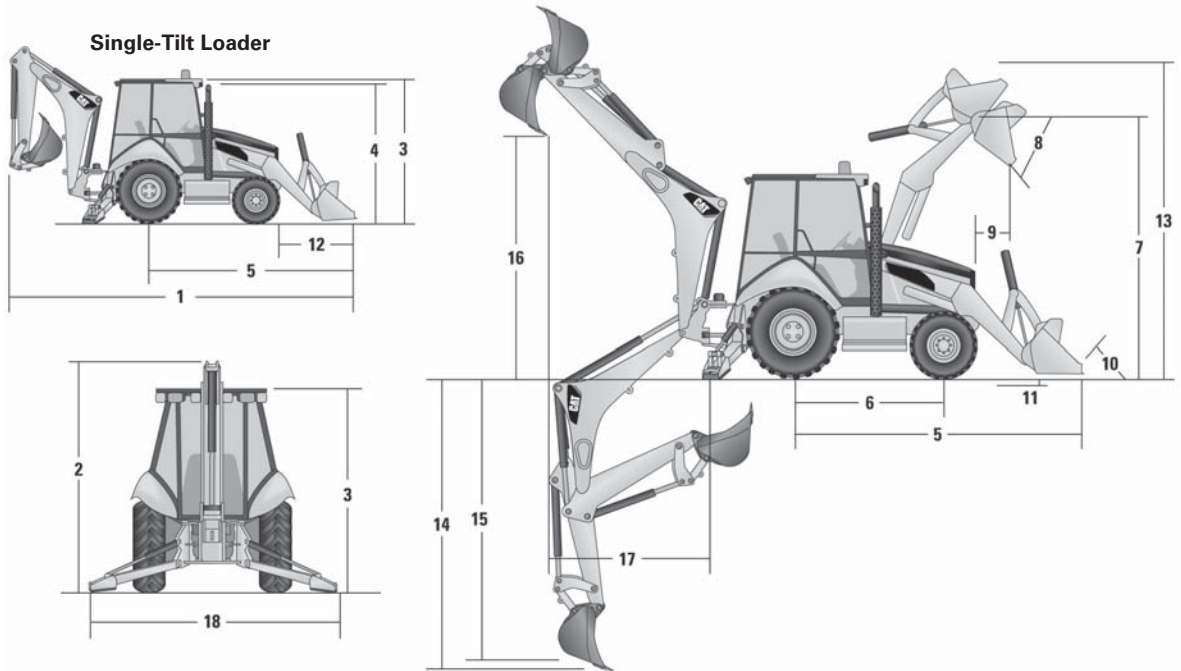

Dimensions and performance specifications shown are for machines equipped with 15-19.5 (12 PR) front tires, 21L-24 (18 PR) rear tires, ROPS canopy, standard stick with 610 mm (24 in) heavy-duty bucket, and 1.3 m³ (1.7 yd³) loader bucket and standard equipment unless otherwise specified.

LOADER BUCKET DIMENSIONS AND PERFORMANCE	Single-Tilt Loader					
	General Purpose 1.3 m ³ (1.7 yd ³)		Multi Purpose 1.15 m ³ (1.5 yd ³)		Multi Purpose with Forks 1.15 m ³ (1.5 yd ³)	
Capacity (SAE) rated	1.3 m ³	1.7 yd ³	1.15 m ³	1.5 yd ³	1.15 m ³	1.5 yd ³
Width	2434 mm	8'0"	2425 mm	7'11"	2425 mm	7'11"
Lift capacity at maximum height	3632 kg	8008 lb	3907 kg	8613 lb	3772 kg	8316 lb
Breakout force	50.7 kN	11,397 lbf	60.9 kN	13,688 lbf	60 kN	13,488 lbf
Tipping load at breakout point	8376 kg	18,466 lb	8160 kg	17,990 lb	8006 kg	17,650 lb
7) Maximum hinge pin height	3501 mm	11'6"	3501 mm	11'6"	3501 mm	11'6"
8) Dump angle at full height		43°		43°		43°
Dump height at maximum angle	2666 mm	8'9"	2759 mm	9'1"	2759 mm	9'1"
9) Dump reach at maximum angle	845 mm	2'9"	774 mm	2'6"	774 mm	2'6"
10) Maximum bucket rollback at ground level		40°		40°		40°
11) Digging depth	146 mm	6"	127 mm	5"	127 mm	5"
Maximum grading angle		106°		109°		109°
Width of dozer cutting edge		N/A	2425 mm	7'11"	2425 mm	7'11"
12) Grill to bucket cutting edge, carry position	1664 mm	5'6"	1571 mm	5'2"	1571 mm	5'2"
13) Maximum operating height	4528 mm	14'10"	4561 mm	15'0"	4881 mm	16'0"
Jaw opening maximum		N/A	864 mm	2'10"	864 mm	2'10"
Bucket jaw clamping force		N/A	39.8 kN	8947 lbf	39.8 kN	8947 lbf
Weight	1132 kg	2495 lb	957 kg	2111 lb	1148 kg	2530 lb

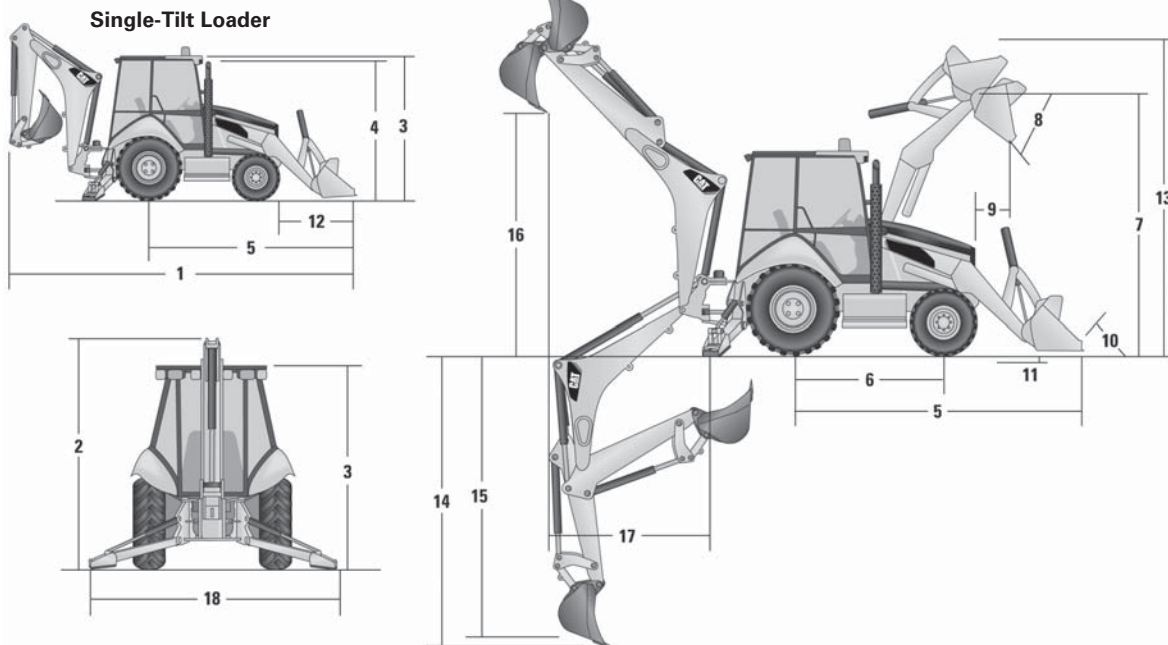

Dimensions and performance specifications shown are for machines equipped with 15-19.5 (12 PR) front tires, 21L-24 (18 PR) rear tires, ROPS canopy, standard stick with 610 mm (24 in) heavy-duty bucket, and 1.3 m³ (1.7 yd³) loader bucket and standard equipment unless otherwise specified.

BACKHOE DIMENSIONS AND PERFORMANCE	Standard Stick		Extendible Stick Retracted		Extendible Stick Extended	
	14) Digging depth, SAE (maximum) Digging depth, 2438 mm (8'0") flat bottom	5260 mm	17'3"	5260 mm	17'3"	6501 mm
15) Digging depth, 610 mm (2'0") flat bottom Reach from rear axle centerline at ground line	4926 mm	16'2"	4926 mm	16'2"	6231 mm	20'5"
16) Reach from swing pivot at ground line Overall operating height Loading height	5224 mm	17'2"	5224 mm	17'2"	6466 mm	21'3"
17) Loading reach Swing arc Bucket rotation	7949 mm	26'1"	7949 mm	26'1"	9130 mm	29'11"
18) Stabilizer spread, operating position (center of pad)	6708 mm	22'0"	6708 mm	22'0"	7890 mm	25'11"
19) Stabilizer spread — operating position (outside edge of pad) Stabilizer spread, transport position Bucket dig force Stick dig force Leveling angle (maximum slope on which machine will make a vertical cut)	6531 mm	21'5"	6531 mm	21'5"	7375 mm	24'2"
	4440 mm	14'7"	4440 mm	14'7"	5194 mm	17'0"
	2175 mm	7'2"	2175 mm	7'2"	3200 mm	10'6"
		175°		175°		175°
		198°		198°		198°
	3614 mm	11'10"	3614 mm	11'10"	3614 mm	11'10"
	4055 mm	13'4"	4055 mm	13'4"	4055 mm	13'4"
	2451 mm	8'0"	2451 mm	8'0"	2451 mm	8'0"
	78.9 kN	17,746 lbf	78.9 kN	17,746 lbf	78.9 kN	17,746 lbf
	52.4 kN	11,780 lbf	53.1 kN	11,939 lbf	40.1 kN	9009 lbf
		13°		13°		13°

KEY

- A — Boom lift kg lb
- B — Stick lift kg lb

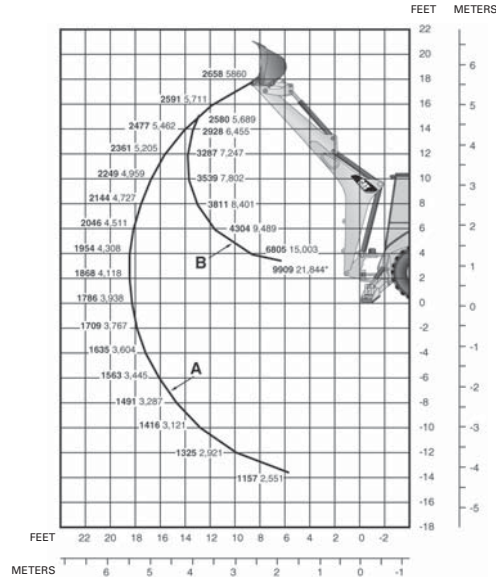

Standard Stick

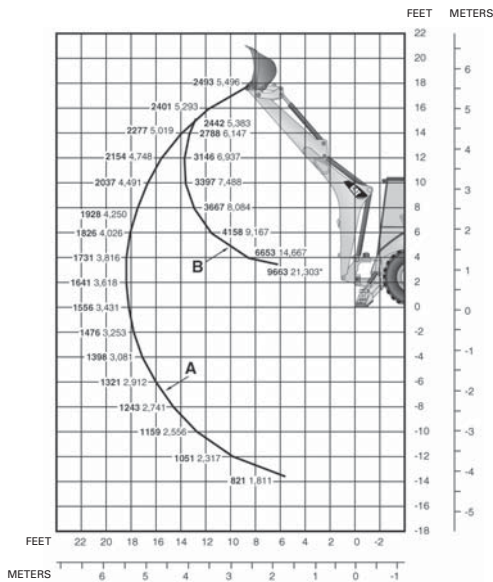

Extendible Stick — Retracted

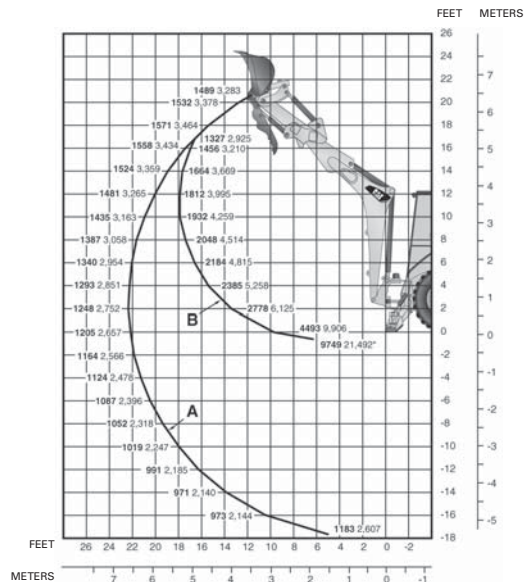

Extendible Stick — Extended

Lift capacities are over-end values per SAE J31; machine equipped with 4WD, OROPS, 1.3 m³ (1.7 yd³) general-purpose loader bucket, 610 mm (24 in) heavy duty backhoe bucket and 985 kg (2200 lb) counterweight.

*Indicates lift capacity is stability limited.

Coral Buckets, Pin-on**415F2, 416F2, 420F2, 430F2****(Americas North, Americas South)**

Width		SAE Capacity		Weight		No. of Teeth
mm	in	L	ft ³	kg	lb	
305	12	65	2.3	123	271	4
457	18	96	3.4	147	324	6
610	24	142	5.0	174	384	8
762	30	190	6.7	200	441	10

Cribbing Buckets, Pin-on**422F2, 427F2, 428F2, 432F2, 434F2, 444F2****(EAME, APD, Americas South)**

Width		SAE Capacity		Weight		No. of Teeth
mm	in	L	ft ³	kg	lb	
230	9	60	2.1	145	320	N/A

Extreme Service Buckets (ES), Pin-on**422F2, 427F2, 428F2, 432F2, 434F2, 444F2****(EAME, APD, Americas South)**

Width		SAE Capacity		Weight		No. of Teeth
mm	in	L	ft ³	kg	lb	
457	18	130	4.6	138	304	4
610	24	200	7.1	173	381	4

Ditch Cleaning Buckets, Pin-on**415F2, 416F2, 420F2, 430F2****(Americas North, Americas South)**

Width		SAE Capacity		Weight		No. of Teeth
mm	in	L	ft ³	kg	lb	
1219	48	368	13.0	205	453	N/A
1372	54	425	15.0	223	491	N/A
1524	60	481	17.0	240	530	N/A

Ditch Cleaning Buckets**422F2, 427F2, 428F2, 432F2, 434F2, 444F2****(EAME, APD, Americas South)**

Width		SAE Capacity		Weight		No. of Teeth
mm	in	L	ft ³	kg	lb	
1200	48	200	7.8	123	271	N/A
1400	54	260	9.2	137	302	N/A
1500	60	290	10.2	145	320	N/A
1600	63	310	10.9	152	335	N/A
1800	70	350	12.4	166	366	N/A

Heavy Duty Buckets (HD), Pin Lock**415F2, 416F2, 420F2, 430F2****(Americas North, Americas South)**

Width		SAE Capacity		Weight		No. of Teeth
mm	in	L	ft ³	kg	lb	
305	12	96	3.4	113	249	3
406	16	122	4.3	131	288	3
457	18	139	4.9	138	304	4
610	24	207	7.3	168	370	5
762	30	275	9.7	194	428	5
914	36	345	12.2	224	494	6

Heavy Duty Buckets (HD), Pin-on**415F2, 416F2, 420F2, 422F2, 427F2,****428F2, 430F2, 432F2, 434F2, 444F2****(Americas North, Americas South, EAME, APD)**

Width		SAE Capacity		Weight		No. of Teeth
mm	in	L	ft ³	kg	lb	
305	12	79	2.8	108	238	3
406	16	105	3.7	127	280	3
457	18	119	4.2	129	284	4
610	24	176	6.2	151	333	5
762	30	232	8.2	167	368	5
914	36	292	10.3	189	417	6

*Bolt-on teeth available.

**Heavy Duty Buckets (HD), Pin-on
450F
(Americas North, Americas South)**

Width		SAE Capacity		Weight		No. of Teeth
mm	in	L	ft ³	kg	lb	
457	18	178	6.3	207	456	3
610	24	269	9.5	246	542	4
762	30	351	12.4	277	611	4
914	36	439	15.5	319	703	6

**Heavy Duty Rock Buckets (HDR), Pin-on
415F2, 416F2, 420F2, 430F2
(Americas North, Americas South)**

Width		SAE Capacity		Weight		No. of Teeth
mm	in	L	ft ³	kg	lb	
305	12	71	2.5	113	250	3
457	18	130	4.6	138	304	4
610	24	200	7.0	173	381	5
762	30	269	9.5	180	396	5
914	36	326	11.5	205	451	6

**High Capacity Buckets, Pin Lock
415F2, 416F2, 420F2, 430F2
(Americas North, Americas South)**

Width		SAE Capacity		Weight		No. of Teeth
mm	in	L	ft ³	kg	lb	
305	12	130	4.6	130	287	3
406	16	159	5.6	148	327	3
457	18	184	6.5	157	346	4
610	24	272	9.6	188	414	5
762	30	365	12.9	215	475	5
914	36	459	16.2	246	543	6

**High Capacity Buckets, Pin-on
415F2, 416F2, 420F2, 430F2
(Americas North, Americas South)**

Width		SAE Capacity		Weight		No. of Teeth
mm	in	L	ft ³	kg	lb	
457	18	181	6.4	146	322	4
914	36	379	13.4	214	472	6

**Soil Excavation Buckets (SE), Pin-on
415F2, 416F2, 420F2, 430F2
(Americas North, Americas South)**

Width		SAE Capacity		Weight		No. of Teeth
mm	in	L	ft ³	kg	lb	
457	18	181	6.4	152	336	4
610	24	241	8.5	179	395	5
762	30	320	11.3	197	434	5
914	36	379	13.4	223	491	6

**Standard Duty Buckets (SD), Pin-on
415F2, 416F2, 420F2, 422F2, 427F2,
428F2, 430F2, 432F2, 434F2, 444F2
(Americas North, Americas South, EAME, APD)**

Width		SAE Capacity		Weight		No. of Teeth
mm	in	L	ft ³	kg	lb	
305	12	78	2.8	97	214	3
457	18	118	4.2	115	254	4
610	24	175	6.2	132	291	5
762	30	233	8.2	147	324	5
914	36	292	10.3	165	364	6

Teeth Options: Penetration
Soil
Sharp
Twin Sharp
Chisel
Wide
Long

Work tools for Cat backhoe loaders are divided into two groups.
For technical questions relating to all work tools inside the U.S.: (800) 282-5384.
Europe, Africa, Middle East: 31 73 63 996 00.

- **Caterpillar Factory Work Tools:** Cat work tools installed on machines or shipped separately from Caterpillar Distribution Services. Includes the most popular work tools such as buckets, forks and material-handling arms. *Order from Machine Orders Division.*
- **Caterpillar Work Tools America Asia Pacific (AAP):** Cat work tools specifically designed for the Cat backhoe loader by the Caterpillar Work Tool division. *Orders inside U.S.: (800) 255-2372. Outside U.S.: 00 1 (785) 456-2224.*

Loader Work Tools	Auxiliary Hydraulics required
1. IT Angle Blade	Multi-Purpose Hydraulics included with IT not required
2. IT Asphalt Cutter	not required
3. IT Bale Spear	Multi-Purpose Hydraulics included with IT not required
4. IT Broom: Angle and Pick-up*	Multi-Purpose Hydraulics included with IT not required
5. IT Bucket, General Purpose	Multi-Purpose Hydraulics included with IT
6. IT Bucket, Multi-Purpose	Multi-Purpose Hydraulics included with IT
7. IT Bucket, Side-Dump	Multi-Purpose Hydraulics included with IT not required
8. IT Forks, Pallet	not required
9. IT Material Handling Arm	not required
10. IT Rake	not required
11. Quick Coupler, IT Hydraulic	Multi-Purpose Hydraulics
12. Single Tilt Bucket, General Purpose	not required
13. Single Tilt Bucket, Multi-Purpose with or without Fold-Over Forks	Multi-Purpose Hydraulics
14. Single Tilt Hydraulic Quick Coupler	includes coupling hydraulics only; can add Multi-Purpose Hydraulics

*Requires the IT Auxiliary Attachments Control (electrical wiring harness).

Backhoe Work Tools	Auxiliary Hydraulics required
1. Auger	Combined Function Hydraulics
2. Bucket, Cemetery	not required
3. Bucket, Coral	not required
4. Bucket, Ditch Cleaning	not required
5. Bucket, Extreme Service	not required
6. Bucket, Heavy Duty	not required
7. Bucket, Heavy Duty Rock	not required
8. Bucket, High Capacity	not required
9. Bucket, Soil Excavation	not required
10. Bucket, Standard Duty	not required
11. Compactor, Vibratory Plate	One Way or Combined Function Hydraulics
12. Hammer, Hydraulic	One Way or Combined Function Hydraulics
13. Quick Coupler, Mechanical Pin-Puller for Cat or Case tools	not required
14. Quick Coupler, Mechanical Pin-Grabber	not required
15. Quick Coupler, Mechanical Pin-Puller for Cat or Deere tools	not required
16. Quick Coupler, Pin Lock	not required
17. Quick Coupler, Side-Tilting Pin Lock	Combined Function Hydraulics
18. Ripper	not required
19. Thumb, Hydraulic	Combined Function Hydraulics
20. Thumb, Mechanical	not required

CONTENTS

ROTARY DRILLS

- Product Line Description3-2
- Applications/Industries Served3-2
- Product Line Chart3-3
- Features3-5
- Key Specifications3-6

TRACK DRILLS

- Product Line Description 3-10
- Applications/Industries Served 3-10
- Product Line Chart 3-10
- Features 3-11
- Key Specifications 3-12
- Shipping Dimensions 3-14

Throughout this document, references to Tier 4 Interim/Stage IIIB/Japan 2011 (Tier 4 Interim) include U.S. EPA Tier 4 Interim, EU Stage IIIB, and Japan 2011 (Tier 4 Interim) emission standards. References to Tier 4 Final/Stage IV/Japan 2014 (Tier 4 Final) include U.S. EPA Tier 4 Final, EU Stage IV, and Japan 2014 (Tier 4 Final) emission standards.

Throughout this document, references to Tier 1/Stage I include U.S. EPA Tier 1 and EU Stage I equivalent emission standards. References to Tier 2/Stage II/Japan 2001 (Tier 2) equivalent include U.S. EPA Tier 2, EU Stage II, and Japan 2001 (Tier 2) equivalent emission standards. References to Tier 3/Stage IIIA/Japan 2006 (Tier 3) equivalent include U.S. EPA Tier 3, EU Stage IIIA, and Japan 2006 (Tier 3) equivalent emission standards.

PRODUCT LINE DESCRIPTION

Cat® Rotary Drills are available in six models, with a maximum bit load range of up to 75 000 kg (165,347 lb), to suit a wide variety of applications. They're proven to deliver efficiency, high productivity and low cost, as well as provide a comfortable environment for the operator. A synergy of robust structures, long-lasting systems and innovative technology, the Cat line of rotary drills have demonstrated their effectiveness and longevity in a variety of mining environments, including both soft- and hard-rock applications, as well as extreme temperature and high-altitude locations. Equipped to handle rotary drills of various sizes and configurations, down-the-hole hammers can also be used on these machine or even dual carousels that accommodate both rotary and DTH. Caterpillar has the drill that delivers the correct amount of bit load, rotary torque and onboard air to ensure your targeted penetration rates.

PRIMARY APPLICATIONS FOR ROTARY BLASTHOLE DRILLS

MODEL	Bench Drilling	Cast Blast Drilling	Presplit Drilling	Grade Control Drilling	Over Burden Drilling
MD6240	x	x	x	x	x
MD6290	x	x	x	x	x
MD6420	x	x	x	x	x
MD6420B	x	x	x	x	x
MD6540	x	x	x		x
MD6640	x	x			x

MODEL	Hole Diameter	Hole Depth	Air Compressor	Engine
MD6240 12 m 15 m	• Up to 244 mm (9.625 in)	<ul style="list-style-type: none"> • Depth single-pass (12 m mast) – Up to 12.80 m (42 ft) • Depth multi-pass – Up to 55.47 m (182 ft) • Depth single-pass (15 m mast) – Up to 15.85 m (52 ft) • Depth multi-pass – Up to 31.08 m (102 ft) 	<ul style="list-style-type: none"> • 48 m³/min (1700 ft³/min) 6.9 bar (100 psi) • 32.6 m³/min (1150 ft³/min) 10.3/24.1 bar (150/350 psi) • 38.3 m³/min (1350 ft³/min) 10.3/24.1 bar (150/350 psi) • 43 m³/min (1500 ft³/min) 34.5 bar (500 psi) 	<ul style="list-style-type: none"> • C27 ACERT™* • 597 kW (800 hp) at 2100 RPM • 652 kW (875 hp) at 2100 RPM
MD6290 8 m 10 m 11 m	• Up to 244 mm (9.625 in)	<ul style="list-style-type: none"> • Depth single-pass (8 m mast) – Up to 8.6 m (28 ft 2 in) • Depth multi-pass – Up to 45.1 m (148 ft) • Depth single-pass (10 m mast) – Up to 10.1 m (33 ft 2 in) • Depth multi-pass – Up to 52.7 m (173 ft) • Depth single-pass (11 m mast) – Up to 11 m (36 ft) • Depth multi-pass – Up to 32.3 m (106 ft) 	<ul style="list-style-type: none"> • 30 m³/min (1050 ft³/min) 8.6 bar (125 psi) • 35.4 m³/min (1250 ft³/min) @ 8.6 bar (125 psi) • 48 m³/min (1700 ft³/min) 6.9 bar (100 psi) • 33 m³/min (1150 ft³/min) 10.3/24.1 bar (150/350 psi) • 38 m³/min (1350 ft³/min) 10.3/24.1 bar (150/350 psi) • 43 m³/min (1500 ft³/min) 10.3/24.1 bar (150/350 psi) 	<ul style="list-style-type: none"> • C15 ACERT** • 403 kW (540 hp) at 2100 RPM • C27 ACERT* • 597 kW (800 hp) at 2100 RPM • C27 ACERT* • 652 kW (875 hp) at 2100 RPM
MD6420 10 m 13 m 16 m	• Up to 311 mm (12.25 in)	<ul style="list-style-type: none"> • Depth single pass (10 m mast) – Up to 10.29 m (33 ft 9 in) • Depth multi-pass – Up to 63.4 m (208 ft) • Depth single pass (13 m mast) – Up to 13.4 m (44 ft) • Depth multi-pass – Up to 74.4 m (244 ft) • Depth single pass (16 m mast) – Up to 16.46 m (54 ft) • Depth multi-pass – Up to 65.2 m (214 ft) 	<ul style="list-style-type: none"> • 67.9 m³/min (2400 ft³/min) 6.9 bar (100 psi) • 42.5 m³/min (1500 ft³/min) 10.3/24.1/34.4 bar (150/350/500 psi) • 67.9 m³/min (2400 ft³/min) 6.9 bar (100 psi) 	<ul style="list-style-type: none"> • C27 ACERT* • 597 kW (800 hp) at 2100 RPM • C27 ACERT* • 652 kW (875 hp) at 2100 RPM • Cummins QST30* 634 and 783 kW (850 and 1050 hp) 783 kW (1050 hp) at 2100 RPM

*This product meets Tier 2 equivalent emission standards.

**This product meets Tier 3, Stage IIIA, and Japan 2006 (Tier 3) equivalent emission standards.

MODEL	Hole Diameter	Hole Depth	Air Compressor	Engine
MD6420B 10 m 13 m 16 m	<ul style="list-style-type: none"> Up to 311 mm (12.25 in) 	<ul style="list-style-type: none"> Depth single pass (10 m mast) – Up to 10.29 m (33 ft 9 in) Depth multi-pass – Up to 63.40 m (208 ft) Depth single pass (13 m mast) – Up to 13.4 m (44 ft) Depth multi-pass – Up to 74.4 m (244 ft) Depth single pass (16 m mast) – Up to 16.46 m (54 ft) Depth multi-pass – Up to 65.2 m (214 ft) 	<ul style="list-style-type: none"> 56.6 m³/min (2000 ft³/min) 6.9 bar (100 psi) 67.9 m³/min (2400 ft³/min) 6.9 bar (100 psi) 42.5 m³/min (1500 ft³/min) 34.4 bar (500 psi) 	<ul style="list-style-type: none"> 627 kW (850 hp) at 1800 RPM QST30C* (non-cert with cense) 786 kW (1050 hp) at 2100 RPM QST30* 627 kW (850 hp) at 1800 RPM AST30C (non-cert with cense) 783 kW (1050 hp) at 2100 RPM
MD6540 16 m 20 m	<ul style="list-style-type: none"> Up to 381 mm (15 in) 	<ul style="list-style-type: none"> Depth single-pass (16 m mast) – Up to 16.15 m (53 ft) Depth multi-pass – Up to 84.73 m (278 ft) Depth single pass (20 m mast) Depth multi-pass – Up to 65.7 m (215.6 ft) 	<ul style="list-style-type: none"> 102 m³/min (3600 ft³/min) 6.9 bar (100 psi) 	<ul style="list-style-type: none"> MTU Detroit Diesel Series 2000 16V* 899 kW (1205 hp) at 1800 RPM
MD6640 19 m 21 m	<ul style="list-style-type: none"> Up to 406 mm (16 in) 	<ul style="list-style-type: none"> Depth single-pass – 19.81 m (65 ft) Depth multi-pass – Up to 39.6 m (130 ft) Depth single-pass – 21.3 m (70 ft) Depth multi-pass – Up to 42.7 m (140 ft) 	<ul style="list-style-type: none"> 85 m³/min (3000 ft³/min) 4.5 bar (65 psi) 107.6 m³/min (3800 ft³/min) 4.5 bar (65 psi) 	<ul style="list-style-type: none"> AC Induction Motor Dual Shaft 447 kW (600 hp) 597 kW (800 hp) 4160V/7200V – 60 Hz 6600/7200V – 60 Hz 5500V – 50 Hz 6600/7200V – 50 Hz 7200V – 50 Hz

*This product meets Tier 2 equivalent emission standards.

CAT ROTARY DRILL FEATURES

Solid Frame

Heavy-duty structural tubing and box section frames provide exceptional durability.

Sturdy Mast

Available in multiple lengths for single pass and multi-pass application. Made of rectangular ASTM 500 Grade B steel tubing on all four main chords, and cross members, creates a torsionally strong mast structure and reduces the material fatigue. All mast structures are designed with double-cut lacing in high stress areas to prevent cracking and assure long life.

Four Jack System

The four jack casing structures are integrally welded to the main frame providing additional torsional strength and overall stability. The welded jack casing structures with the location of the jacks will reduce the frame torsional flexing and assure longer life for frame structure.

HOBO Wrench

The Hydraulically Operated Break Out wrench is a highly efficient breakout system that increases speed of pipe changing operations and consequently increases the productivity. It also reduces the forces which affect to the mast and rotary head during the pipe changing procedure and increase the drill mechanical availability.

NOTE: MD6640 does not store complete drill string in pipe racks.

Power Group

Fast cycle times are achieved through top of class bit load, rotary head horsepower, bailing air and a multitude of time-saving systems for maximum efficiency.

Carousel Pipe Rack Option

The patented hammer/tricone carousel places complete drill strings with either DTH/bit or tricone bit in the carousel. It provides rapid pipe changes that are safe and efficient and completely controlled from inside of operator's cab. A hydraulic break out wrench and deck wrench assist in breaking thread connections quickly and effectively.

Ergonomic Cab

The FOPS certified operator's cab features an ergonomic operator's chair, well organized controls and temperature/pressure controlled environment. Walls, ceiling and floor are sound and thermally insulated keeping the noise level low.

Dust Control System

Created by the stationary deck and 6.4 cm (¼") thick nylon reinforced rubber dust curtains, the dust chamber assures high dust collection efficiency and natural dust containment, with ample space for deep hole drilling and resulting cutting pile.

MODEL	MD6240	MD6290	MD6420
Hole Diameter	• Up to 244 mm (9.625 in)	• Up to 244 mm (9.625 in)	• Up to 311 mm (12.25 in)
Hole Depth	<ul style="list-style-type: none"> • Depth single-pass (12 m mast) – Up to 12.80 m (42 ft) • Depth multi-pass – Up to 55.47 m (182 ft) • Depth single-pass (15 m mast) – Up to 15.85 m (52 ft) • Depth multi-pass – Up to 31.08 m (102 ft) 	<ul style="list-style-type: none"> • Depth single-pass (8 m mast) – Up to 8.6 m (28 ft 2 in) • Depth multi-pass – Up to 45.1 m (148 ft) • Depth single-pass (10 m mast) – Up to 10.1 m (33 ft 2 in) • Depth multi-pass – Up to 52.7 m (173 ft) • Depth single-pass (11 m mast) – Up to 11 m (36 ft) • Depth multi-pass – Up to 32.3 m (106 ft) 	<ul style="list-style-type: none"> • Depth single pass (10 m mast) – Up to 10.29 m (33 ft 9 in) • Depth multi-pass – Up to 63.4 m (208 ft) • Depth single pass (13 m mast) – Up to 13.4 m (44 ft) • Depth multi-pass – Up to 75.3 m (247 ft) • Depth single pass (16 m mast) – Up to 16.46 m (54 ft) • Depth multi-pass – Up to 46.9 m (154 ft)
Compressor	<ul style="list-style-type: none"> • 48 m³/min (1700 ft³/min) 6.9 bar (100 psi) • 32.6 m³/min (1150 ft³/min) 10.3/24.1 bar (150/350 psi) • 38.3 m³/min (1350 ft³/min) 10.3/24.1 bar (150/350 psi) • 43 m³/min (1500 ft³/min) 34.5 bar (500 psi) 	<ul style="list-style-type: none"> • 30 m³/min (1050 ft³/min) 8.6 bar (125 psi) • 35 m³/min (1250 ft³/min) 8.6 bar (125 psi) • 48 m³/min (1700 ft³/min) 6.9 bar (100 psi) • 33 m³/min (1150 ft³/min) 10.3/24.1 bar (150/350 psi) • 38 m³/min (1350 ft³/min) 10.3/24.1 bar (150/350 psi) • 43 m³/min (1500 ft³/min) 10.3/24.1 bar (150/350 psi) 	<ul style="list-style-type: none"> • 42.5 m³/min (1500 ft³/min) 10.3/24.1 bar (150/350 psi) • 67.9 m³/min (2400 ft³/min) 6.9 bar (100 psi) • 42.5 m³/min (1500 ft³/min) 10.3/24.1/34.4 bar (150/350/500 psi) • 56.6 m³/min (2000 ft³/min) 6.9 bar (100 psi)
Cooler (ambient rating)	• 52° C (125° F)	• 52° C (125° F)	• 52° C (125° F)
Engine	<ul style="list-style-type: none"> • C27 ACERT* – 597 kW (800 hp) at 2100 RPM • C27 ACERT* – 652 kW (875 hp) at 2100 RPM 	<ul style="list-style-type: none"> • C15 ACERT** – 403 kW (540 hp) at 2100 RPM • C27 ACERT* – 597 kW (800 hp) at 2100 RPM • C27 ACERT* – 652 kW (875 hp) at 2100 RPM 	<ul style="list-style-type: none"> • C27 ACERT* – 597 kW (800 hp) at 2100 RPM • C27 ACERT* – 652 kW (875 hp) at 2100 RPM • Cummins QST30* 634 and 783 kW (850 and 1050 hp) 783 kW (1050 hp) at 2100 RPM

*This product meets Tier 2 equivalent emission standards.

**This product meets Tier 3, Stage IIIA, and Japan 2006 (Tier 3) equivalent emission standards.

MODEL	MD6240	MD6290	MD6420
Cab	• FOPS	• FOPS	• FOPS
Fuel Tank	• 2896 L (765 U.S. gal)	• 2461 L (650 U.S. gal)	• 3218 L (850 U.S. gal) or 4164 L (1100 U.S. gal)
Hydraulic Tank	• 643 L (170 U.S. gal)	• 644 L (170 U.S. gal)	• 10 m mast: 1007 L (266 U.S. gal) • 13 or 16 m mast: 1208 L (319 U.S. gal)
Pipe Rack	• Outside Mast Carousel, with stationary pods and breaker plates	• Outside Mast Carousel, with stationary breaker plates	• Inside Mast Carousel, with stationary pods and breaker plates
Drill Pipe Capacity	<ul style="list-style-type: none"> • 114-178 mm (4.5-7 in) • 12 m mast 4 pods: – 10.67 m (35 ft) pipe • 15 m mast 2 pods: – 7.62 m (25 ft) pipe 	<ul style="list-style-type: none"> • 114 to 178 mm (4.5 to 7 in)/ 8 m (26 ft 3 in) • 8 m mast 4 pods: – 9.14 m (30 ft) pipe • 10 m mast 4 pods: – 9.14 m (30 ft) pipe • 11 m mast 2 pods: – 9.14 m (30 ft) or – 10.67 m (35 ft) pipe 	<ul style="list-style-type: none"> • 10 m mast 5 pods: – 9.14 m (30 ft) pipe • 13 m mast 4 or 5 pods: – 12.19 m (40 ft) pipe • 16 m mast 4 pods: – 7.62 m (25 ft) pipe – 12.19 m (40 ft) pipe
Tram Speed Maximum	• 2.0 km/h (1.25 mph)	• 3.14 km/h (1.95 mph)	<ul style="list-style-type: none"> • 10 m mast – 2.14 km/h (1.33 mph) • 13/16 m mast – 2.27 km/h (1.41 mph)
Angle Hole Drilling	• Up to 25 degree off vertical, in 5 degree increments	• Up to 25 degree off vertical, in 5 degree increments	• Up to 25 degree off vertical, in 5 degree increments

MODEL	MD6420B	MD6540
Hole Diameter	<ul style="list-style-type: none"> Up to 311 mm (12.25 in) 	<ul style="list-style-type: none"> Up to 381 mm (15 in)
Hole Depth	<ul style="list-style-type: none"> Depth single pass (10 m mast) – Up to 10.29 m (33 ft 9 in) Depth multi-pass – Up to 63.40 m (208 ft) Depth single pass (13 m mast) – Up to 13.4 m (44 ft) Depth multi-pass – Up to 74.4 m (244 ft) Depth single pass (16 m mast) – Up to 16.46 m (54 ft) Depth multi-pass – Up to 46.9 m (154 ft) 	<ul style="list-style-type: none"> Depth single-pass (16 m mast) – Up to 16.15 m (53 ft) Depth multi-pass – Up to 84.73 m (278 ft) Depth single pass (20 m mast) Depth multi-pass – Up to 65.7 m (215.6 ft)
Compressor	<ul style="list-style-type: none"> 56.6 m³/min (2000 ft³/min) 6.9 bar (100 psi) 67.9 m³/min (2400 ft³/min) 6.9 bar (100 psi) 42.5 m³/min (1500 ft³/min) 10.3/24.1/34.4 bar (150/350/500 psi) 	<ul style="list-style-type: none"> 102 m³/min (3600 ft³/min) 6.9 bar (100 psi)
Cooler (ambient rating)	<ul style="list-style-type: none"> 52° C (125° F) 	<ul style="list-style-type: none"> 52° C (125° F)
Engine	<ul style="list-style-type: none"> Cummins QST30 (non-cert with cense) – 786 kW (1050 hp) at 1000 RPM Cummins QST30 (non-cert with cense) – 783 kW (1050 hp) at 2100 RPM Cummins QST30* 627 kW (850 hp) at 1800 RPM 	<ul style="list-style-type: none"> MTU Detroit Diesel Series 2000 16V* – 899 kW (1205 hp) at 1800 RPM
Cab	<ul style="list-style-type: none"> FOPS 	<ul style="list-style-type: none"> FOPS
Fuel Tank	<ul style="list-style-type: none"> 3217 L (850 U.S. gal) 	<ul style="list-style-type: none"> Total 3289 L (869 U.S. gal)
Hydraulic Tank	<ul style="list-style-type: none"> 1208 L (319 U.S. gal) 	<ul style="list-style-type: none"> 1363 L (360 U.S. gal)
Pipe Rack	<ul style="list-style-type: none"> Inside Mast Carousel, with stationary pods and breaker plates 	<ul style="list-style-type: none"> Inside Mast Carousel, with stationary pods and breaker plates
Drill Pipe Capacity	<ul style="list-style-type: none"> 10 m configuration 5 pipes: – 10.67 m (35 ft) pipe – 219 mm (8.625 in) OD 13 m configuration 5 pipes: – 12.19 m (40 ft) pipe – 219 mm (8.625 in) OD 16 m configuration 4 pipes: – 7.62 m (25 ft) pipe – 194 mm (7.625 in) OD 	<ul style="list-style-type: none"> 16 m mast: – 13.7 m (45 ft) pipe – 194 mm (7.625 in) through 235 mm (9.25 in) OD (5 each) 20 m mast: 9.1 m (30 ft) pipe – 254 mm (10 in) and 273 mm (10.75 in) OD (4 each)
Angle Hole Drilling	<ul style="list-style-type: none"> Up to 30 degree off vertical, in 5 degree increments 	<ul style="list-style-type: none"> Up to 30 degree off vertical, in 5 degree increments
Tram Speed Maximum	<ul style="list-style-type: none"> 2.27 km/h (1.41 mph) 	<ul style="list-style-type: none"> 2.09 km/h (1.03 mph)

*This product meets Tier 2 equivalent emission standards.

MODEL	MD6640
Hole Diameter	<ul style="list-style-type: none"> • Up to 406 mm (16 in)
Hole Depth	<ul style="list-style-type: none"> • Depth Single-pass 19.81 m (65 ft) • Depth Multi-pass up to 39.6 m (130 ft) • Depth Single-pass 21.3 m (70 ft) • Depth Multi-pass up to 42.7 m (140 ft)
Compressor	<ul style="list-style-type: none"> • 85 m³/min (3000 ft³/min) 4.5 bar (65 psi) • 107.6 m³/min (3800 ft³/min) 4.5 bar (65 psi)
Cooler (ambient rating)	<ul style="list-style-type: none"> • 50° C (122° F)
Main Motor	<ul style="list-style-type: none"> • AC Induction Motor • Dual Shaft • 447 kW (600 hp) or 597 kW (800 hp) • 4160V/7200V – 60 Hz • 7200V – 50 Hz
Cab	<ul style="list-style-type: none"> • FOPS
Fuel Tank	<ul style="list-style-type: none"> • Not available
Hydraulic Tank	<ul style="list-style-type: none"> • 420 L (111 U.S. gal)
Pipe Rack	<ul style="list-style-type: none"> • Single Rack; or Dual pipe rack available. Both located inside of mast and swing out in line with drill string
Drill Pipe Capacity	<ul style="list-style-type: none"> • 19.81 m (65 ft) mast 2 pods: – 9.90 m (32.5 ft) pipe (2 pipes per pod) or • 21.3 m (70 ft) mast 2 pods: – 10.66 m (35 ft) pipe (2 pipes per pod) • 235 to 340 mm (9.25 to 13.375 in) OD pipe • Single or double pipe racks
Tram Speed Maximum	<ul style="list-style-type: none"> • 1.77 km/h (1.1 mph)
Angle Hole Drilling	<ul style="list-style-type: none"> • Up to 25 degree off vertical, in 5 degree increments

PRODUCT LINE DESCRIPTION

Cat Track Drills are designed for optimum performance and serviceability, while maintaining the ruggedness and reliability our customers have come to expect. With a rock drill that has the lowest number of parts in the industry our customers can enjoy higher uptime and lower maintenance cost as a result of owning Cat Track Drills. Track drills are for use in mining, construction and quarry applications.

PRIMARY APPLICATIONS FOR TRACK DRILLS IN MINING, QUARRIES AND CONSTRUCTION

MODEL	Pipeline	Pioneering	Basements	Tie Bolting	Trenching	Site Prep	Highway Road Cut	Hydro Electric	Wind Farm	Prod Drill – Small Q & M	Prod Drill – Medium Q & M	Prod Drill – Large Q & M	Wall Control	Presplit
MD5050 ¹	x	x	x	x	x	x			x					
MD5050T ²	x		x	x	x	x			x					
MD5090 ³	x	x	x	x	x	x								
MD5075 ⁴					x	x	x	x	x	x		x	x	
MD5150C ⁵							x	x	x	x	x	x	x	x

¹ Cab/extension boom.
² Cab/extension boom/knuckle boom.
³ Non cab/extension boom/larger compressor.
⁴ Cab/extension boom/knuckle boom/larger compressor.
⁵ Cab/extension boom/larger compressor/3.66 or 4.27 m (12 or 14 ft) steel.

PRODUCT LINE CHART

MODEL	Hole Diameter	Hole Depth	Air Compressor	Rock Drill	Engine
MD5050	• Up to 102 mm (4.0 in)	• Up to 31.2 m (102.5 ft)	• 7.08 m ³ /min @ 10.2 bar (250 ft ³ /min @ 150 psi)	• HPR4519 19 kW (25 hp)	• 4HK* 150 kW (203 hp) at 2100 RPM
MD5050T	• Up to 102 mm (4.0 in)	• Up to 31.2 m (102.5 ft)	• 7.08 m ³ /min @ 10.2 bar (250 ft ³ /min @ 150 psi)	• HPR4519 19 kW (25 hp)	• 4HK* 150 kW (203 hp) at 2100 RPM
MD5075	• Up to 127 mm (5 in)	• Up to 31.2 m (102.5 ft)	• 9.78 m ³ /min @ 10.2 bar (350 ft ³ /min @ 150 psi)	• HPR4519 19 kW (25 hp)	• Cat C9 ACERT* 224 kW (300 hp) at 1800 RPM
MD5090	• Up to 127 mm (5 in)	• Up to 22.1 m (72.5 ft)	• 8.5 m ³ /min @ 10.2 bar (300 ft ³ /min @ 150 psi)	• HPR4519 19 kW (25 hp)	• Cat C9 ACERT* 224 kW (300 hp) at 1800 RPM
MD5150C	• Up to 152 mm (6 in)	• Up to 31.2 m (102.5 ft)	• 15.1 m ³ /min @ 9.6 bar (534 ft ³ /min @ 140 psi)	• HPR5128 28 kW (37 hp)	• Cat C11 ACERT* 287 kW (385 hp) at 1800 RPM

*This product meets Tier 3, Stage IIIA, and Japan 2006 (Tier 3) equivalent emission standards.

CAT TRACK DRILL FEATURES

Used in construction, quarry, and mining applications providing effective drilling capabilities and high uptime.

Vast Pattern Coverage

Multiple pattern coverage configurations available. Solid boom extensions improve drilling by providing up to an additional 1.5 m (5.0 ft) of pattern coverage. The optional knuckle boom, available on some models, extends reach to 5.8 m (19.25 ft) and is used in rough terrain to reach up, down and over objects.

Robust Boom

The boom features an improved weldment design, and the square tubing is reinforced in heavily-loaded areas to provide thousands of hours of trouble-free service.

Superior Carousel Rod Changer

Unlike linear alternatives, our carousel rod changer weighs less and holds more rods, allowing the boom extension to reach further and drill deeper while maintaining stability. The feed and carousel rod hanger can accommodate two lengths and diameters of drill steel. This design eliminates fragile electronics and sensors and replaces them with robust mechanical structures.

Ergonomic Cab Design

Most Cat Track Drills have cabs with rollover and/or falling object protection, excellent visibility, and responsive controls. Some cabs are designed for front window push-out, which offers a second exit for the operator in case of emergency. The cab is also equipped with an emergency stop for immediate shutdown.

Sturdy Frame

The Cat Track Drill main frame is a box-section design comprised of 102 mm × 203 mm × 12.7 mm (4 in × 8 in × ½ in) rectangular steel tubing, heavily reinforced in high-stress areas.

Cat Rock Drills

Low cost of ownership and reliability are yours with renowned Cat Rock Drills. Building on a legacy of simplistic power, these drills have long life expectancy and are field serviceable. This combination of robust design and easy maintenance means more hours of reliable, low-cost operation. For added efficiency, the pistons are matched to the cross section of the rod so the wave form is properly matched for maximum energy transfer.

Rock Drills Are Owner Serviceable

Cat Rock Drills are so simple that owner serviceability is a viable alternative and cost savings.

- Other models require downtime for round trip transportation to a clean room environment.
- Some Cat Rock Drills maintenance can be performed with the rock drill still mounted on the feed and in your own shop.
- Accumulator assemblies may be replaced in the field.
- Troubleshooting is easy since there are half the components of other drills.

Rock Drills Have a Durable Design

A simple design coupled with high strength materials yields exceptional durability.

- Having only half of the components of competitive models, there are fewer internal parts to wear.
- There are four major housings bolted together with high strength flanges eliminating troublesome long tie rods.
- Long life alloy bushings.

MODEL	MD5050	MD5050T**	MD5075
Hole Diameter	• Up to 102 mm (4.0 in)	• Up to 102 mm (4.0 in)	• Up to 127 mm (5.0 in)
Hole Depth	• Up to 31 m (102.5 ft)	• Up to 31 m (102.5 ft)	• Up to 31 m (102.5 ft)
Rock Drill Power*	• 19 kW (25 hp)	• 19 kW (25 hp)	• 19 kW (25 hp)
Compressor	• 7 m ³ /min (250 ft ³ /min)	• 7 m ³ /min (250 ft ³ /min)	• 9.9 m ³ /min (350 ft ³ /min)
Cooler	• 52° C (125° F)	• 52° C (125° F)	• 52° C (125° F)
Engine	• 4HK*** 4-cylinder inline turbocharged, water-cooled, direct injection, 150 kW (203 bhp) at 2100 RPM	• 4HK*** 4-cylinder inline turbocharged, water-cooled, direct injection, 150 kW (203 bhp) at 2100 RPM	• Cat C9 ACERT,*** electronically controlled, 6-cylinder inline turbocharged, air-to-air after-cooled 224 kW (300 bhp) at 1800 RPM
Cab	• ROPS/FOPS	• ROPS/FOPS	• ROPS/FOPS
Fuel Tank	• 303 L (80 U.S. gal)	• 303 L (80 U.S. gal)	• 492 L (130 U.S. gal)
Hydraulic Tank	• 379 L (100 U.S. gal)	• 379 L (100 U.S. gal)	• 405 L (107 U.S. gal)
Boom Length	• 2.9 m (9.5 ft) with 0.6 m (2.0 ft) telescopic extension	• 2.9 m (9.5 ft) with 1.2 m (4.0 ft) telescopic extension	• 3.81 m (12.5 ft) with 1.5 m (5.0 ft) telescopic extension
Rod Changer	• Carousel with 6 rods × 3.66 m (12 ft) or 6 rods × 4.27 m (14 ft)	• Carousel with 6 rods × 3.66 m (12 ft) or 6 rods × 4.27 m (14 ft)	• Carousel with 6 rods × 3.66 m (12 ft) or 6 rods × 4.27 m (14 ft)
Drill Steel Diameter	• 45 or 51 mm (1.75 or 2 in) steel	• 45 or 51 mm (1.75 or 2 in) steel	• 45 or 51 mm (1.75 or 2 in) steel
Ground Clearance	• 406 mm (16 in)	• 434.5 mm (17 in)	• 380 mm (15 in)
Tram Speed Max.	• 4.8 km/h (3.0 mph)	• 4 km/h (2.5 mph)	• 4 km/h (2.5 mph)
Track Oscillation	• ±10°	• ±0°	• ±10°

*Each model can take multiple sizes of rock drills and drill steel. Standard is listed.

**MD5050T is mounted on a turntable base for 360 degree rotation.

***This product meets Tier 3, Stage IIIA, and Japan 2006 (Tier 3) equivalent emission standards.

MODEL	MD5090	MD5150C
Hole Diameter	• Up to 127 mm (5.0 in)	• Up to 152 mm (6.0 in)
Hole Depth	• Up to 22.1 m (72.5 ft)	• Up to 31 m (102.5 ft)
Rock Drill Power*	• 19 kW (25 hp)	• 28 kW (37 hp)
Compressor	• 8.5 m ³ /min (300 ft ³ /min)	• 15.1 m ³ /min (534 ft ³ /min)
Cooler	• 52° C (125° F)	• 52° C (125° F)
Engine	• Cat C9 ACERT,** electronically controlled, 6-cylinder inline turbocharged, air-to-air after-cooled 224 kW (300 bhp) at 1800 RPM	• Cat C11 ACERT,** electronically controlled, 6-cylinder inline turbocharged, air-to-air after-cooled 287 kW (385 bhp) at 1800 RPM
Cab	• Non-cab	• ROPS/FOPS
Fuel Tank	• 492 L (130 U.S. gal)	• 618 L (163.3 U.S. gal)
Hydraulic Tank	• 405 L (107 U.S. gal)	—
Boom Length	• 3.81 m (12.5 ft) with 1.5 m (5.0 ft) telescopic extension	• 2.7 m (9 ft) with 0.9 m (3 ft) telescopic extension
Rod Changer	• Manual 5 rods × 3.66 m (12 ft)	• Carousel with 6 rods × 3.66 m (12 ft) or 6 rods × 4.27 m (14 ft)
Drill Steel Diameter	• 38, 45 or 51 mm (1.5, 1.75 or 2 in) steel	• 51, 60 or 68 mm (2, 2.34 or 2.68 in) steel
Ground Clearance	• 431 mm (17 in)	• 400 mm (15.75 in)
Tram Speed Max.	• 4 km/h (2.4 mph)	• 4 km/h (2.5 mph)
Track Oscillation	• ±10°	• ±11°

*Each model can take multiple sizes of rock drills and drill steel. Standard is listed.

**This product meets Tier 3, Stage IIIA, and Japan 2006 (Tier 3) equivalent emission standards.

SHIPPING DIMENSIONS

MODEL	MD5050		MD5050T		MD5075	
Length	10.7 m	35 ft	11.4 m	37.3 ft	12.3 m	40.4 ft
Width	2.6 m	8.5 ft	2.6 m	8.5 ft	2.6 m	8.5 ft
Height	3.2 m	10.5 ft	3.5 m	11.5 ft	3.4 m	11.3 ft
Weight	12 700 kg	28,000 lb	15 512 kg	34,200 lb	19 504 kg	43,000 lb

MODEL	MD5090		MD5150C	
Length	10.3 m	33.8 ft	10.8 m	35 ft 2 in
Width	2.6 m	8.5 ft	2.6 m	8.5 ft
Height	3.1 m	10.3 ft	3.2 m	10 ft 7.33 in
Weight	18 597 kg	41,000 lb	20 412 kg	45,000 lb

CONTENTS

Design Data	4-2
Rating Explanations	4-2
Basic Specifications	4-3
MaK™ Marine Propulsion Engines	4-5
Rental Generator Sets	4-8
Cat® Generator Sets	4-9, 4-13
MaK Marine Generator Sets	4-11
Cat Marine Engines	4-17
Cat Industrial Diesel Applications	4-19
Cat Oil and Gas Engines	4-29
Cat Railway Power	4-37

Asia
Caterpillar Asia Pte., Ltd.
 Jurong, Singapore
 Tel: 65-6828-7118
 Fax: 65-6828-7414

Australia
Caterpillar of Australia Pty. Ltd.
 Victoria, Australia
 Tel: 61-3-9953-9301
 Fax: 61-3-9338-9021

China
Caterpillar China Ltd.
 Beijing, China
 Tel: 86-10-5921-0339
 Fax: 86-10-5921-0022

Eastern Europe Commonwealth of Independent States
Caterpillar Overseas S.A.
 Moscow, Russia
 Tel: 7-095-755-8161
 Fax: 7-095-785-5688

Europe, Africa, Middle East
Caterpillar S.A.R.L.
 Geneva, Switzerland
 Tel: 41-22-849-4444
 Fax: 41-22-849-4139

Japan
Caterpillar Power Systems, Inc.
 Tokyo, Japan
 Tel: 81-3-5786-3800
 Fax: 81-3-5786-3809





Mexico, The Caribbean, South America Latin America Commercial Division
 Miami, Florida, U.S.A.
 Tel: 305-476-6800
 Fax: 305-476-6850

North America
Caterpillar Inc.
 Peoria, Illinois, U.S.A.
 Tel: 309-578-6298
 Fax: 309-578-2559

E Mail:
 Cat_Power@Cat.com

Web Site/Dealer Locator
www.Cat-engines.com

For more information contact your local Cat dealer, or visit the Cat engine and generator set website on www.cat-engines.com.

	TYPE	NO. OF MODELS	RANGE
	INDUSTRIAL Diesel	54	8.2 to 4920 kW 11.0 to 6598 hp
	Gaseous Fueled	14	71 to 6100 kW 95 to 8180 hp
	GENERATOR SETS		50 Hz kVA w/fan Prime 6.8-3600 Standby 7.5-4000
	Diesel High Speed Area		60 Hz ekW w/fan Prime 6.8-3600 Standby 7.5-4000
	Gaseous Fueled		50 Hz ekW w/o fan Continuous 66-9700 60 Hz ekW w/o fan Continuous 235-9700
	MARINE Propulsion	23	93 to 5650 kW 125 to 7577 bhp
	Generator Sets	16	50 Hz kVA 10.0 to 6500 Prime 60 Hz kW 12.0 to 4840 Prime
	POWER AND PRODUCTION		50 Hz 1140 to 18 000 kW Prime
	Generator Sets	28	1529 to 24,138 hp Prime 60 Hz 1020 to 18 000 kW 1368 to 24,138 hp
	Pump Application	11	1140 to 6100 kW 1529 to 8180 hp

NOTE: For specific emission standards per model and rating, please see pages 4-19 through 4-20.

DESIGN DATA***Diesel Engines**

Bearings – Precision-type steel-backed aluminum alloy with lead-tin overlay copper bonded to bearing surface. High load carrying ability and exceptional fatigue strength.

Block – Cast from high tensile strength grey iron. Internal ribbing provides added strength.

Cooling – Built-in, gear driven centrifugal pump circulates jacket water through engine at all times. Water temperature is thermostatically controlled. Heat exchangers and radiators are available.

Crankshaft – Forged steel, dynamically balanced, heat treated and superfinished.

Cylinder Liners – Internal surface induction hardened (1.7 L, 3300, 3400, 3500 and 3600 Families) for excellent wear life. Full-length watercooled for efficient heat transfer.

Fuel System – Adjustment free for reduced engine maintenance, individual fuel injection pumps have built-in calibration — no adjustment required after fuel nozzle replacement (1.7 L, 1.9 L, 3406E, 3456, 3500 and 3600 families have unit injectors). 3126, 3408E and 3412E use the Cat HEUI™ system.

Governor – Hydra-mechanical (Woodward 3161 on 3500 and 3600 Families) for reliability, good response and smooth, stable load changes. Electronically controlled engines use Caterpillar proprietary software and hardware.

Lubrication – Positive displacement gear pump maintains continuous flow of lubricant under pressure to all moving parts. Full-flow filtration is provided by replaceable cellulose filters. Watercooled oil cooler maintains proper oil temperature.

Pistons – Three-ring design (two-ring on 3208) reduces friction, provides excellent oil control, and increases engine efficiency.

Starting – Electric and air starting systems are offered for most models.

Valves – Hardened steel alloy. Valves rotate 3° each time they lift to seat in a new position and allow even heat distribution (except for 3116).

*Except for MaK and CM engines.

Gaseous Fueled Engines

Combustion System – The piston design and compression ratios available provide the ability to utilize a wide variety of gaseous fuels as well as provide low emission output (below 2.0 grams/bhp-hr No_x).

Fuel System – Heavy-duty, industrial-type carburetors designed to maintain optimum air-fuel ratio at all loads and speeds.

Ignition System – Cat Gaseous Fueled Engines employ a low tension magneto, together with an ignition transformer (one at each cylinder), to provide up to 34 kV to spark plugs. The Cat Electronic Ignition system is also available on certain engines.

RATING EXPLANATIONS

All engine ratings listed include such standard accessories as air cleaner and fuel, lube, and jacket water pumps. Power required for auxiliaries such as cooling fans, air compressors, charging alternators, special pumps, etc., must be deducted to arrive at the net power available to drive the load (except as noted). Other ratings are available for specific application and customer requirements, i.e., locomotive, oil field, fire pump, irrigation, etc. Consult your Cat dealer.

Rating Conditions

Performance is based on SAE J1995 standard conditions of 100 kPa (29.61 in Hg) and 25° C (77° F). Performance also applies at ISO 3046-1 (except for Spark Ignited Engines), DIN 6271 and BS 5514 standard conditions of 100 kPa (29.61 in Hg), 27° C (81° F) and 60% relative humidity.

Fuel consumption is based on fuel oil having an LHV of 42 780 kJ/kg (18,390 Btu/lb) and weighing 838.9 g/liter (7.001 lb/U.S. gal). All ratings are based on distillate fuel.

Altitude and Temperature Capabilities

Industrial Diesel Engines – Most intermittent and continuous ratings are applicable to at least 1320 m (5000 ft) elevation without derating. Consult factory for specific applications.

Gaseous Fueled Engines – Ratings for turbocharged and aftercooled engines are generally applicable to 1500 m (5000 ft). Naturally aspirated engines are applicable to 150 m (500 ft).

Diesel Truck Engines – Refer to specification sheets for altitude capability of individual truck engine ratings.

Basic Specifications

Model	Displacement		Config.	Bore x Stroke		Fuel System	Power Range					
	L	in ³		mm	in		Marine		Industrial	Elec. Power Gen.	Oil/ Gas	Rail Power
							bkW	bhp				
C0.5	0.5	31	I2	67x72	2.6x2.8	PC						
C0.7	0.7	46.4	I3	67x72	2.6x2.8	PC						
C1.1	1.1	69	I3	77x81	3.0x3.2	PC						
C1.5*	1.5	91	I3	84x90	3.3x3.5	PC						
C1.5	1.5	91	I3	84x90	3.3x3.5	PC or Common Rail						
C1.6	1.5	92	I4	77x81	3.0x3.2	PC						
C1.7	1.66	101	I3	84x100	3.3x3.9	PC						
C2.2*	2.2	135	I4	84x100	3.3x3.9	PC						
C2.2	2.2	135	I4	84x100	3.3x3.9	Common Rail						
C3.4B	3.4	207.5	I4	99x110	3.9x4.3	Common Rail						
3054C*	4.4	269	I4	105x127	4.1x5.0							
C4.4*	4.4	269	I4	105x127	4.1x5.0	Common Rail						
C4.4 ACERT™*	4.4	269	I4	105x127	4.1x5.0	Common Rail						
C4.4 ACERT	4.4	269	I4	105x127	4.1x5.0	Common Rail						
C6.6 ACERT*	6.6	402.8	I6	105x127	4.1x5.0	Common Rail						
C6.6 ACERT*	6.6	402.8	I6	105x127	4.1x5.0	Common Rail						
3056	6	365	I6	100x127	3.94x5.0	MEUI™	93-153	125-205				
C7	7.24	442	I6	110x127	4.33x5.0	HEUI	187-276	250-370				
C7 ACERT*	7.2	442	I6	110x127	4.33x5.0	HEUI	339	455				
C7.1*	7	427.7	I6	105x135	4.13x5.3	Common Rail						
C7.1 ACERT*	7	427.7	I6	105x135	4.13x5.3	Common Rail						
C7.1 ACERT	7	427.7	I6	105x135	4.13x5.3	Common Rail						
C9 ACERT*	8.8	537	I6	112x149	4.41x5.87	Common Rail	375-423	503-567				
C9.3 ACERT	9.3	567.5	I6	115x149	4.53x5.87	Common Rail						
C11 ACERT*	11.1	677	I6	130x140	5.12x5.51	MEUI						
C11 ACERT	11.1	677	I6	130x140	5.12x5.51	MEUI						
C12	12	732	I6	130x150	5.1x5.9	MEUI	254-448	340-600				
C12 ACERT	12	732	I6	130x150	5.1x5.9	MEUI	492-526	660-705				
C13 ACERT*	12.5	763	I6	130x157	5.1x6.2	MEUI						
C13 ACERT	12.5	762.8	I6	130x157	5.1x6.2	MEUI						
3406C*	14.6	893	I6	137x165	5.4x6.5							
C15 ACERT*	15.2	927.6	I6	137.2x171.4	5.4x6.75	MEUI						
C15 ACERT	15.2	927.6	I6	137x171	5.4x6.73	MEUI						
C16	15.8	964	I6	140x171	5.5x6.75	MEUI						
C18 ACERT*	18.1	1104.5	I6	145x183	5.7x7.2	MEUI						
C18 ACERT	18.1	1104.5	I6	145x183	5.7x7.2	MEUI						
C18 ACERT	18.1	1106	I6	145x183	5.7x7.2	MEUI	350-847	469-1136				
C27 ACERT*	27	1648	V12	137.2x152.4	5.4x6.0	MEUI						
C27 ACERT	27	1649.5	V12	137.2x152.4	5.4x6.0	MEUI						
C32 ACERT*	32.1	1959	V12	145x162	5.7x6.4	MEUI						
C32 ACERT	32.1	1959	V12	145x162	5.7x6.4	MEUI	559-1417	750-1900				

See our listings for Diesel Industrial for complete information.

See our listings for Generator Sets and Power Modules for complete information.

See our listings for Oil and Gas Engines for complete information.

See our listings for Railway Power for complete information.

PC — Precombustion Chamber

MEUI — Mechanical Unit Injection

HEUI — Hydraulically Actuated Electronically Controlled

NOTE: Industrial models meet current U.S. EPA Tier 4 Final, EU Stage IIIA, IIIB, or IV emission standards, unless otherwise noted with an *.

Models with an * are available for other global regulated and non-regulated areas.

Basic Specifications

Model	Displacement		Config.	Bore x Stroke		Fuel System	Power Range					
	L	in ³		mm	in		Marine		Diesel Industrial	Elec. Power Gen.	Oil/Gas	Rail Power
							bkW	bhp				
3508*	34.5	2105	V8	170x190	6.7x7.5	MEUI	526-857	705-1150	See our listings for Diesel Industrial for complete information.	See our listings for Generator Sets and Power Modules for complete information.	See our listings for Oil and Gas Engines for complete information.	See our listings for Railway Power for complete information.
3508B*	34.5	2105	V8	170x190	6.7x7.5	MEUI	578-1118	775-1500				
3508C	34.5	2107	V8	170x190	6.7x7.5	MEUI	578-820	775-1100				
3512*	51.8	3158	V12	170x190	6.7x7.5	MEUI	900-1305	1207-1750				
3512B*	51.8	3158	V12	170x190	6.7x7.5	MEUI	820-1678	1100-2250				
3512B HD	58.6	3576	V12	170x215	6.7x8.5	MEUI	1118-1500	1500-2012				
3512C	51.8	3161	V12	170x190	6.69x7.48	MEUI	955-1765	1280-2365				
3512C HD	58.6	3574	V12	170x215	6.69x8.46	MEUI	1118-1902	1500-2551				
3516*	69	4210	V16	170x190	6.7x7.5	MEUI	1195-1491	1603-2000				
3516B*	69	4210	V16	170x190	6.7x7.5	MEUI	1230-2237	1650-3000				
3516B HD	78	4766	V16	170x215	6.7x8.5	MEUI	1398-2000	1875-2682				
3516C	69	4211	V16	170x190	6.69x7.48	MEUI	1230-2525	1650-3386				
3516C HD	78	4765	V16	170x215	6.69x8.46	MEUI	1686-2525	2260-3386				
C175-16	84.67	5167	V16	175x220	6.88x8.66	Common Rail	2001-2550	2683-3420				
C280-6	111	6773	I6	280x300	11.0x11.8	MEUI	1730-2030	2320-2722				
C280-8	148	9031	I8	280x300	11.0x11.8	MEUI	2300-2710	3084-3634				
C280-12	222	13,546	V12	280x300	11.0x11.8	MEUI	3460-4060	4640-5444				
C280-16	296	18,062	V16	280x300	11.0x11.8	MEUI	4600-5650	6169-7577				

MEUI — Mechanical Unit Injection

NOTE: Industrial models meet current U.S. EPA Tier 4 Final, EU Stage IIIA, IIIB, or IV emission standards, unless otherwise noted with an *.

Models with an * are available for other global regulated and non-regulated areas.

Basic Specifications – MaK Marine Propulsion Engines

MaK Model	Output Range		Speed rpm	Mean Eff. Pressure bar	Mean Piston Speed m/s	Bore mm	Stroke mm	Swept Volume L	Dimensions						Weight t
	kW	mhp							Length mm	Width mm	Height 1 Dry/Wet Sump mm	Height 2 mm	RCLTD* mm	RCLLD** mm	
6 M 20 C	1020	1390	900	24.1	9.0	200	300	57	4049	1558	630/941	1714	1910	2085	10.9
	1080	1469	900	25.5	9.0	200	300	57	4049	1558	630/941	1714	1910	2085	10.9
	1140	1550	1000	24.2	10.0	200	300	57	4049	1558	630/941	1714	1910	2085	10.9
	1200	1632	1000	25.5	10.0	200	300	57	4049	1558	630/941	1714	1910	2085	10.9
8 M 20 C	1360	1850	900	24.1	9.0	200	300	75	4846	1693	630/941	1856	1910	2085	13.8
	1440	1958	900	25.5	9.0	200	300	75	4846	1693	630/941	1856	1910	2085	13.8
	1520	2070	1000	24.2	10.0	200	300	75	4846	1693	630/941	1856	1910	2085	13.8
	1600	2176	1000	25.5	10.0	200	300	75	4846	1693	630/941	1856	1910	2085	13.8
9 M 20 C	1530	2082	900	24.1	9.0	200	300	85	5176	1693	630/941	1856	1910	2085	15.0
	1620	2203	900	25.5	9.0	200	300	85	5176	1693	630/941	1856	1910	2085	15.0
	1710	2326	1000	24.2	10.0	200	300	85	5176	1693	630/941	1856	1910	2085	15.0
	1800	2448	1000	25.5	10.0	200	300	85	5176	1693	630/941	1856	1910	2085	15.0
6 M 25 C	1740	2370	720	23.7	9.6	255	400	123	5345	2261	861/1191	2526	2510	2735	23.5
	1800	2450	750	23.5	10.0	255	400	123	5345	2261	861/1191	2526	2510	2735	23.5
	2000	2720	720	27.2	9.6	255	400	123	5345	2261	861/1191	2526	2510	2735	23.5
	2000	2720	750	26.1	10.0	255	400	123	5345	2261	861/1191	2526	2510	2735	23.5
8 M 25 C	2320	3160	720	23.7	9.6	255	400	163	6289	2316	861/1191	2578	2510	2735	30.0
	2400	3260	750	23.5	10.0	255	400	163	6289	2316	861/1191	2578	2510	2735	30.0
	2666	3630	720	27.2	9.6	255	400	163	6289	2316	861/1191	2578	2510	2735	30.0
	2666	3630	750	26.1	10.0	255	400	163	6289	2316	861/1191	2578	2510	2735	30.0
9 M 25 C	2610	3550	720	23.7	9.6	255	400	184	6719	2316	861/1191	2578	2510	2735	32.0
	2700	3670	750	23.5	10.0	255	400	184	6719	2316	861/1191	2578	2510	2735	32.0
	3000	4080	720	27.2	9.6	255	400	184	6719	2316	861/1191	2578	2510	2735	32.0
	3000	4080	750	26.1	10.0	255	400	184	6719	2316	861/1191	2578	2510	2735	32.0
6 M 32 C	3000	4080	600	25.9	9.6	320	480	232	5934	2418	1052/1387	2784	3040	3405	39.5
8 M 32 C	4000	5440	600	25.9	9.6	320	480	309	7298	2229	1052/1387	2969	3040	3405	49.0
9 M 32 C	4500	6120	600	25.9	9.6	320	480	347	7828	2229	1052/1387	2969	3040	3405	52.0
6 M 25 E	2100	2856	720	28.5	9.6	255	400	123	5345	2261	861/1191	2526	2510	2735	23.5
	2100	2856	750	27.4	10.0	255	400	123	5345	2261	861/1191	2526	2510	2735	23.5
8 M 25 E	2800	3808	720	28.5	9.6	255	400	163	6289	2316	861/1191	2578	2510	2735	30.0
	2800	3808	750	27.4	10.0	255	400	163	6289	2316	861/1191	2578	2510	2735	30.0
9 M 25 E	3150	4284	720	28.5	9.6	255	400	184	6719	2316	861/1191	2578	2510	2735	32.0
	3150	4284	750	27.4	10.0	255	400	184	6719	2316	861/1191	2578	2510	2735	32.0
6 M 32 E	3300	4488	720	24.8	11.0	320	460	222	6148	2368	1052/1387	2771	3040	3400	37.5
	3300	4488	750	23.8	11.5	320	460	222	6148	2368	1052/1387	2771	3040	3400	37.5
8 M 32 E	4400	5984	720	24.8	11.0	320	460	296	7318	2182	1052/1387	2908	3040	3400	46.4
	4400	5984	750	23.8	11.5	320	460	296	7318	2182	1052/1387	2908	3040	3400	46.4
9 M 32 E	4950	6732	720	24.8	11.0	320	460	333	7848	2182	1052/1387	2908	3040	3400	49.4
	4950	6732	750	23.8	11.5	320	460	333	7848	2182	1052/1387	2908	3040	3400	49.4

General definition of engine ratings: ISO 3046-1 – (IACS)
 Meets IMO MARPOL Annex VI NO_x requirements
 Reference Conditions: Air Temperature: 25° C Air Pressure: 1 bar
 Cooling water temperature at charge air cooler inlet: mean 30° C, max. 38° C

*Removal of Cylinder Liner in Transverse Direction.
 **Removal of Cylinder Liner in Longitudinal Direction.

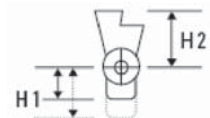

Dimensions of engine length for turbocharger at driving end, dimensions for turbocharger at free end on request.

Basic Specifications – MaK Marine Propulsion Engines

MaK Model	Output Range		Speed	Mean Eff. Pressure	Mean Piston Speed	Bore	Stroke	Swept Volume	Dimensions						Weight
									Length	Width	Height 1 Dry/Wet Sump	Height 2	RCLTD*	RCLLD**	
	kW	mhp	rpm	bar	m/s	mm	mm	L	mm	mm	mm	mm	mm	mm	t
12 M 32 C	6000	8160	720	22.5	11.0	320	460	444	6956	2985	1205/—	2319	2836	—	65.0
	6000	8160	750	21.6	11.5	320	460	444	6956	2985	1205/—	2319	2836	—	65.0
16 M 32 C	8000	10,880	720	22.5	11.0	320	460	592	8328	2985	1205/—	2319	2836	—	82.0
	8000	10,880	750	21.6	11.5	320	460	592	8328	2985	1205/—	2319	2836	—	82.0
12 M 32 E	6360	8650	720	23.9	11.0	320	460	444	6956	2985	1205/—	2319	2836	—	65.0
	6360	8650	750	22.9	11.5	320	460	444	6956	2985	1205/—	2319	2836	—	65.0
	6720	9139	720	25.2	11.0	320	460	444	6956	2985	1205/—	2319	2836	—	65.0
	6720	9139	750	24.2	11.5	320	460	444	6956	2985	1205/—	2319	2836	—	65.0
16 M 32 E	8480	11,533	720	23.9	11.0	320	460	592	8328	2985	1205/—	2319	2836	—	82.0
	8480	11,533	750	22.9	11.5	320	460	592	8328	2985	1205/—	2319	2836	—	82.0
	8960	12,186	720	25.2	11.0	320	460	592	8328	2985	1205/—	2319	2836	—	82.0
	8960	12,186	750	24.2	11.5	320	460	592	8328	2985	1205/—	2319	2836	—	82.0
6 M 34 DF	3000	4080	720	19.9	11.0	340	460	250	6148	2368	1052/1387	2771	3040	3400	39.5
	3000	4080	750	19.1	11.5	340	460	250	6148	2368	1052/1387	2771	3040	3400	39.5
8 M 34 DF	4000	5440	720	19.9	11.0	340	460	334	7318	2182	1052/1387	2908	3040	3400	49.0
	4000	5440	750	19.1	11.5	340	460	334	7318	2182	1052/1387	2908	3040	3400	49.0
9 M 34 DF	4500	6120	720	19.9	11.0	340	460	376	7848	2182	1052/1387	2908	3040	3400	52.0
	4500	6120	750	19.1	11.5	340	460	376	7848	2182	1052/1387	2908	3040	3400	52.0
6 M 43 C	5400	7344	500	24.4	10.2	430	610	531	8271	2878	1396/—	3734	4165	4610	94.0
	5400	7344	514	23.7	10.5	430	610	531	8271	2878	1396/—	3734	4165	4610	94.0
	6000	8160	500	27.1	10.2	430	610	531	8271	2878	1396/—	3734	4165	4610	94.0
	6000	8160	514	26.4	10.5	430	610	531	8271	2878	1396/—	3734	4165	4610	94.0
	6300	8568	500	28.4	10.2	430	610	531	8271	2878	1396/—	3734	4165	4610	94.0
	6300	8568	514	27.7	10.5	430	610	531	8271	2878	1396/—	3734	4165	4610	94.0
	7000	9520	500	27.1	10.2	430	610	620	9068	2878	1396/—	4105	4165	4610	107.0
	7000	9520	514	26.4	10.5	430	610	620	9068	2878	1396/—	4105	4165	4610	107.0
7 M 43 C	7350	9996	500	28.4	10.2	430	610	620	9068	2878	1396/—	4105	4165	4610	107.0
	7350	9996	514	27.7	10.5	430	610	620	9068	2878	1396/—	4105	4165	4610	107.0
	7200	9792	500	24.4	10.2	430	610	709	9798	2878	1396/—	4105	4165	4610	114.0
	7200	9792	514	23.7	10.5	430	610	709	9798	2878	1396/—	4105	4165	4610	114.0
8 M 43 C	8000	10,880	500	27.1	10.2	430	610	709	9798	2878	1396/—	4105	4165	4610	114.0
	8000	10,880	514	26.4	10.5	430	610	709	9798	2878	1396/—	4105	4165	4610	114.0
	8400	11,424	500	28.4	10.2	430	610	709	9798	2878	1396/—	4105	4165	4610	114.0
	8400	11,424	514	27.7	10.5	430	610	709	9798	2878	1396/—	4105	4165	4610	114.0

General definition of engine ratings: ISO 3046-1 – (IACS)

Meets IMO MARPOL Annex VI NO_x requirements

Reference Conditions: Air Temperature: 25° C Air Pressure: 1 bar

Cooling water temperature at charge air cooler inlet: mean 30° C, max. 38° C

*Removal of Cylinder Liner in Transverse Direction.

**Removal of Cylinder Liner in Longitudinal Direction.

Dimensions of engine length for turbocharger at driving end, dimensions for turbocharger at free end on request.

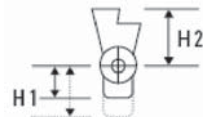

Basic Specifications – MaK Marine Propulsion Engines

MaK Model	Output Range		Speed	Mean Eff. Pressure	Mean Piston Speed	Bore	Stroke	Swept Volume	Dimensions						Weight
									Length	Width	Height 1 Dry/Wet Sump	Height 2	RCLTD*	RCLLD**	
9 M 43 C	8100	11,016	500	24.4	10.2	430	610	797	10 528	2878	1396/—	4105	4165	4610	127.0
	8100	11,016	514	23.7	10.5	430	610	797	10 528	2878	1396/—	4105	4165	4610	127.0
	9000	12,240	500	27.1	10.2	430	610	797	10 528	2878	1396/—	4105	4165	4610	127.0
	9000	12,240	514	26.4	10.5	430	610	797	10 528	2878	1396/—	4105	4165	4610	127.0
	9450	12,852	500	28.4	10.2	430	610	797	10 528	2878	1396/—	4105	4165	4610	127.0
	9450	12,852	514	27.7	10.5	430	610	797	10 528	2878	1396/—	4105	4165	4610	127.0
12 M 43 C	10 800	14,688	500	24.4	10.2	430	610	1063	9842	3890	1625/—	3497	3700	—	160.0
	10 800	14,688	514	23.7	10.5	430	610	1063	9842	3890	1625/—	3497	3700	—	160.0
	12 000	16,320	500	27.1	10.2	430	610	1063	9842	3890	1625/—	3497	3700	—	160.0
	12 000	16,320	514	26.4	10.5	430	610	1063	9842	3890	1625/—	3497	3700	—	160.0
	12 600	17,136	500	28.4	10.2	430	610	1063	9842	3890	1625/—	3497	3700	—	160.0
	12 600	17,136	514	27.7	10.5	430	610	1063	9842	3890	1625/—	3497	3700	—	160.0
16 M 43 C	14 400	19,584	500	24.4	10.2	430	610	1417	11 943	4027	1625/—	3473	3700	—	220.0
	14 400	19,584	514	23.7	10.5	430	610	1417	11 943	4027	1625/—	3473	3700	—	220.0
	16 000	21,760	500	27.1	10.2	430	610	1417	11 943	4027	1625/—	3473	3700	—	220.0
	16 000	21,760	514	26.4	10.5	430	610	1417	11 943	4027	1625/—	3473	3700	—	220.0
	16 800	22,848	500	28.4	10.2	430	610	1417	11 943	4027	1625/—	3473	3700	—	220.0
	16 800	22,848	514	27.7	10.5	430	610	1417	11 943	4027	1625/—	3473	3700	—	220.0
6 M 46 DF	5400	7344	500	21.3	10.2	460	610	608	8271	2878	1396/—	3734	4165	4610	94.0
	5400	7344	514	20.7	10.5	460	610	608	8271	2878	1396/—	3734	4165	4610	94.0
7 M 46 DF	6300	8568	500	21.3	10.2	460	610	709	8985	2878	1396/—	4105	4165	4610	107.0
	6300	8568	514	20.7	10.5	460	610	709	8985	2878	1396/—	4105	4165	4610	107.0
8 M 46 DF	7200	9792	500	21.3	10.2	460	610	811	9800	2878	1396/—	4105	4165	4610	114.0
	7200	9792	514	20.7	10.5	460	610	811	9800	2878	1396/—	4105	4165	4610	114.0
9 M 46 DF	8100	11,016	500	21.3	10.2	460	610	912	10 525	2878	1396/—	4105	4165	4610	127.0
	8100	11,016	514	20.7	10.5	460	610	912	10 525	2878	1396/—	4105	4165	4610	127.0
12 M 46 DF	10 800	14,688	500	21.3	10.2	460	610	1216	9847	3890	1625/—	3497	3700	—	160.0
	10 800	14,688	514	20.7	10.5	460	610	1216	9847	3890	1625/—	3497	3700	—	160.0
16 M 46 DF	14 400	19,584	500	21.3	10.2	460	610	1621	11 943	4027	1625/—	3473	3700	—	220.0
	14 400	19,584	514	20.7	10.5	460	610	1621	11 943	4027	1625/—	3473	3700	—	220.0

General definition of engine ratings: ISO 3046-1 – (IACS)
 Meets IMO MARPOL Annex VI NO_x requirements
 Reference Conditions: Air Temperature: 25° C Air Pressure: 1 bar
 Cooling water temperature at charge air cooler inlet: mean 30° C, max. 38° C

- *Removal of Cylinder Liner in Transverse Direction.
- **Removal of Cylinder Liner in Longitudinal Direction.

Dimensions of engine length for turbocharger at driving end, dimensions for turbocharger at free end on request.

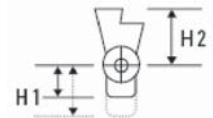

Engines

Rental Generator Sets

- Diesel Ratings
- Gas Ratings

Rental Generator Sets*

Diesel Ratings

50 Hz				
Model	rpm	Standby	Prime	Continuous
		kVA		
3-Phase Output				
XQE20	1500	—	20	—
XQE30	1500	—	30	—
XQE60	1500	—	60	—
XQE100	1500	—	100	—
XQE150	1500	—	150	—
XQE200	1500	—	200	—
XQE250	1500	—	250	—
XQC1200	1500	—	—	1150 ekW
XQ2000 DGB	1500	—	2000	1750
XQ2000	1500	—	2000	1750
XQC1600	1500	—	—	1515 ekW
60 Hz				
Model	rpm	Standby	Prime	Continuous
		ekW		
XQ20	1800	20	18	—
XQ30	1800	30	27	—
XQ200	1800	200	182	—
XQC1200	1800	—	—	1150
XQ2000	1800	—	—	2000
XQC1600	1800	—	—	1515
kVA				
XQ35	1800	38	34	—
XQ60	1800	63	57	—
XQ425	1800	469	425	—
XQ570	1800	625	568	—

Gas Ratings

Model	rpm	Standby	Prime	Continuous
		ekW		
XG135	1800	—	—	135
XQ1475	1500	—	—	1475

*Price list only products.

Cat Generator Sets

Gas Ratings

60 Hz		
Model	Standby	Continuous
	ekW	
1800 rpm		
G3306	—	76
G3306	—	87
G3306	—	104
G3406	215	137
G3306	—	143
G3406	—	155
G3406	—	192
G3412	—	194
G3406	—	217
G3412C	375	253
CG132-8	—	400
G3412	—	403
G3412C	500	453
CG132-12	—	600
G3512	—	615
CG132-16	—	800
G3516	1000	—
G3516C	1500	—
G3516C	—	1663
G3520C	—	2077

60 Hz		
Model	Standby	Continuous
	ekW	
1500 rpm		
CG170-12	—	1200
CG170-16	—	1550
G3520C	—	1936
CG170-20	—	2000
G3516H	—	2005
G3520E	—	2026
G3520H	—	2500
1200 rpm		
G3516	—	779
G3516	—	824
G3516	—	1015
G3516B	—	1312
G3520C	—	1626
900 rpm		
CG260-12	—	3000
CG260-16	—	3370
CG260-16	—	4000
720 rpm		
G16CM34	—	6520
G20CM34	—	9700

Rating Definitions:

Standby — These ratings are applicable for supplying continuous electrical power (at variable load) in the event of a utility power failure. No overload is permitted on these ratings. Natural gas ratings have been established on natural gas with net calorific Low Heat Value (LHV) of approximately 36.2 mJ/m³ (920 Btu/ft³).

Continuous — Output available without varying load for an unlimited time. Continuous power in accordance with ISO 8528, ISO 3046-1, AS2789, DIN6271, and BS5514. Natural gas ratings have been established on natural gas with net calorific Low Heat Value (LHV) of approximately 36.2 mJ/m³ (920 Btu/ft³).

Cat Generator Sets

Gas Ratings

50 Hz	
Model	Continuous ekW
1500 rpm	
G3306	66
G3306	86
G3406	107
G3306	115
G3406	126
G3406	166
G3412	174
G3412	282
G3412C	374
G3412C	400
CG132-12	600
CG132-16	800
G3516	983
G3512E	1017
G3516	1041
G3516	1088
G3516	1105
CG170-12	1200
G3512E	1211
CG170-16	1560
G3516E	1603
G3516C	1605
G3520C	1982
CG170-20	2000
G3520C	2010
G3516H	2027
G3520H	2519

50 Hz	
Model	Continuous ekW
1000 rpm	
CG260-12	3333
G3616	3440
CG260-16	3770
CG260-16	4500
750 rpm	
G16CM34	6520
G20CM34	9700

Rating Definitions:

Standby — These ratings are applicable for supplying continuous electrical power (at variable load) in the event of a utility power failure. No overload is permitted on these ratings. Natural gas ratings have been established on natural gas with net calorific Low Heat Value (LHV) of approximately 36.2 mJ/m³ (**920 Btu/ft³**).

Continuous — Output available without varying load for an unlimited time. Continuous power in accordance with ISO 8528, ISO 3046-1, AS2789, DIN6271, and BS5514. Natural gas ratings have been established on natural gas with net calorific Low Heat Value (LHV) of approximately 36.2 mJ/m³ (**920 Btu/ft³**).

MaK Marine Generator Sets
Medium Speed Ratings

MaK Model	Output Range			Frequency	Speed	Bore	Stroke	Dimensions*			Weight*
								Single Length	Single Width	Single Height	
	kW	kWe	kVA	Hz	rpm	mm	mm	mm	mm	mm	t
6 M 20 C	1020	979	1224	60	900	200	300	6073	1680	2833	18.8
	1080	1036	1296	60	900	200	300	6073	1680	2833	18.8
	1140	1094	1368	50	1000	200	300	6073	1680	2833	18.8
	1200	1151	1440	50	1000	200	300	6073	1680	2833	18.8
8 M 20 C	1360	1306	1632	60	900	200	300	6798	1816	3010	23.1
	1440	1381	1728	60	900	200	300	6798	1816	3010	23.1
	1520	1459	1824	50	1000	200	300	6798	1816	3010	23.1
	1600	1534	1920	50	1000	200	300	6798	1816	3010	23.1
9 M 20 C	1530	1468	1836	60	900	200	300	7125	1816	3010	30.0
	1620	1553	1944	60	900	200	300	7125	1816	3010	30.0
	1710	1641	2052	50	1000	200	300	7125	1816	3010	30.0
	1800	1726	2160	50	1000	200	300	7125	1816	3010	30.0
6 M 25 C	1740	1669	2088	60	720	255	400	8070	2479	3911	43.0
	1800	1726	2160	50	750	255	400	8070	2479	3911	43.0
	2000	1918	2400	60	720	255	400	8070	2479	3911	43.0
	2000	1918	2400	50	750	255	400	8070	2479	3911	43.0
8 M 25 C	2320	2225	2784	60	720	255	400	9130	2534	3963	53.0
	2400	2302	2880	50	750	255	400	9130	2534	3963	53.0
	2666	2557	3199	60	720	255	400	9130	2534	3963	53.0
	2666	2557	3199	50	750	255	400	9130	2534	3963	53.0
9 M 25 C	2610	2503	3132	60	720	255	400	9516	2534	3963	56.0
	2700	2589	3240	50	750	255	400	9516	2534	3963	56.0
	3000	2877	3600	60	720	255	400	9516	2534	3963	56.0
	3000	2877	3600	50	750	255	400	9516	2534	3963	56.0
6 M 32 C	3000	2877	3600	50/60	600	320	480	9302	2639	4801	73.0
8 M 32 C	4000	3836	4800	50/60	600	320	480	10 886	2600	4869	92.0
9 M 32 C	4500	4316	5400	50/60	600	320	480	11 419	2600	4869	98.0
6 M 25 E	2100	2014	2520	60	720	255	400	8070	2479	3911	43.0
	2100	2014	2520	50	750	255	400	8070	2479	3911	43.0
8 M 25 E	2800	2685	3360	60	720	255	400	9130	2534	3963	53.0
	2800	2685	3360	50	750	255	400	9130	2534	3963	53.0
9 M 25 E	3150	3021	3780	60	720	255	400	9516	2534	3963	56.0
	3150	3021	3780	50	750	255	400	9516	2534	3963	56.0
6 M 32 E	3300	3165	3960	60	720	320	460	9302	2639	4788	71.0
	3300	3165	3960	50	750	320	460	9302	2639	4788	71.0
8 M 32 E	4400	4220	5280	60	720	320	460	10 886	2600	4808	89.4
	4400	4220	5280	50	750	320	460	10 886	2600	4808	89.4
9 M 32 E	4950	4747	5940	60	720	320	460	11 419	2600	4808	95.4
	4950	4747	5940	50	750	320	460	11 419	2600	4808	95.4

*Weights and measures depend on generator make/type.
 Generator efficiency: 0.96, cos φ 0.8
 Specific lubricating oil consumption 0.6 g/kWh, ± 0.3 g/kWh
 LCV = 42 700 kJ/kg, without engine-driven pumps, tolerance 5%

MaK Marine Generator Sets
Medium Speed Ratings

MaK Model	Output Range			Frequency	Speed	Bore	Stroke	Dimensions*			Weight*
								Single Length	Single Width	Single Height	
	kW	kWe	kVA	Hz	rpm	mm	mm	mm	mm	mm	t
12 M 32 C	6000	5754	7200	60	720	320	460	10 703	3526	4639	120.0
	6000	5754	7200	50	750	320	460	10 703	3526	4639	120.0
16 M 32 C	8000	7672	9600	60	720	320	460	12 149	3526	4639	140.0
	8000	7672	9600	50	750	320	460	12 149	3526	4639	140.0
12 M 32 E	6360	6099	7632	60	720	320	460	10 703	3526	4639	120.0
	6360	6099	7632	50	750	320	460	10 703	3526	4639	120.0
	6720	6444	8064	60	720	320	460	10 703	3526	4639	120.0
16 M 32 E	6720	6444	8064	50	750	320	460	10 703	3526	4639	120.0
	8480	8132	10 176	60	720	320	460	12 149	3526	4639	140.0
	8480	8132	10 176	50	750	320	460	12 149	3526	4639	140.0
6 M 34 DF	8960	8593	10 752	60	720	320	460	12 149	3526	4639	140.0
	8960	8593	10 752	50	750	320	460	12 149	3526	4639	140.0
	3000	2877	3600	60	720	340	460	9302	2639	4788	73.0
8 M 34 DF	3000	2877	3600	50	750	340	460	9302	2639	4788	73.0
	4000	3836	4800	60	720	340	460	10 886	2600	4808	92.0
9 M 34 DF	4000	3836	4800	50	750	340	460	10 886	2600	4808	92.0
	4500	4316	5400	60	720	340	460	11 419	2600	4808	98.0
6 M 43 C	4500	4316	5400	50	750	340	460	11 419	2600	4808	98.0
	5400	5179	6480	50/60	500/514	430	610	12 202	3400	6278	178.0
7 M 43 C	6000	5754	7200	50/60	500/514	430	610	12 202	3400	6278	178.0
	6300	6042	7560	50/60	500/514	430	610	12 202	3400	6278	178.0
	6300	6042	7560	50/60	500/514	430	610	12 999	3400	6649	195.0
8 M 43 C	7000	6713	8400	50/60	500/514	430	610	12 999	3400	6649	195.0
	7350	7049	8820	50/60	500/514	430	610	12 999	3400	6649	195.0
	7200	6905	8640	50/60	500/514	430	610	13 729	3400	6649	210.0
9 M 43 C	8000	7672	9600	50/60	500/514	430	610	13 729	3400	6649	210.0
	8400	8056	10 080	50/60	500/514	430	610	13 729	3400	6649	210.0
	8100	7768	9720	50/60	500/514	430	610	14 459	3400	6649	240.0
12 M 43 C	9000	8631	10 800	50/60	500/514	430	610	14 459	3400	6649	240.0
	9450	9063	11 340	50/60	500/514	430	610	14 459	3400	6649	240.0
	10 800	10 357	12 960	50/60	500/514	430	610	14 740	3890	6517	275.0
16 M 43 C	12 000	11 508	14 400	50/60	500/514	430	610	14 740	3890	6517	275.0
	12 600	12 083	15 120	50/60	500/514	430	610	14 740	3890	6517	275.0
	14 400	13 810	17 280	50/60	500/514	430	610	16 870	4027	6493	345.0
6 M 46 DF	16 000	15 344	19 200	50/60	500/514	430	610	16 870	4027	6493	345.0
	16 800	16 111	20 160	50/60	500/514	430	610	16 870	4027	6493	345.0
	5400	5179	6480	50/60	500/514	460	610	12 202	3400	6278	178.0
7 M 46 DF	6300	6042	7560	50/60	500/514	460	610	12 999	3400	6649	195.0
8 M 46 DF	7200	6905	8640	50/60	500/514	460	610	13 729	3400	6649	210.0
9 M 46 DF	8100	7768	9720	50/60	500/514	460	610	14 459	3400	6649	240.0
12 M 46 DF	10 800	10 357	12 960	50/60	500/514	460	610	14 740	3890	6517	275.0
16 M 46 DF	14 400	13 810	17 280	50/60	500/514	460	610	16 870	4027	6493	345.0

*Weights and measures depend on generator make/type.

Generator efficiency: 0.96, $\cos \varphi$ 0.8

Specific lubricating oil consumption 0.6 g/kWh, \pm 0.3 g/kWh

LCV = 42 700 kJ/kg, without engine-driven pumps, tolerance 5%

Cat Generator Sets

Diesel Ratings

60 Hz			
Model	rpm	Standby	Prime
		ekW	
3-Phase Output*			
D40	1800	40	36
D50	1800	50	45
D60	1800	60	55
D80	1800	80	72
D100	1800	100	90
D125	1800	125	114
D150	1800	150	136
D175	1800	175	158
D200	1800	200	—
Single Phase Output**			
D40S	1800	40	36
D50S	1800	50	45
D60S	1800	60	55
D80S	1800	80	72
D100S	1800	100	90

*All ratings at 0.8 pf.
**All ratings at 1.0 pf.

60 Hz			
Model	Standby	Prime	Continuous
			ekW
1800 rpm			
C9	200	180	—
C9	250	225	—
C9	300	275	—
3406C	300	275	—
C15	350	320	—
C13	350	320	—
C13	400	350	—
C15	400	365	—
C15	450	410	—
C15	500	455	—
C18	550	500	—
C18	600	545	—
3412C	650	591	—
3412C	700	635	—
C27	750	680	—
3412C	750	680	—
C27	800	725	—
3412C	800	725	—
C32	1000	910	830
3512	1100	1000	890
3512	1250	1135	1010
3512B	1400	1275	—
3512B	1500	1360	1230
3512C	1500	1360	1230
3516	1750	1600	1450
3516B	2000	1825	1640
3516C	2000	1825	1650
3516B	2250	—	—
3516C-HD	2500	2250	2050
C175-16	3000	2725	2500
C175-16	3100	2825	2600
C175-20	4000	3600	3250

Rating Definitions:

Standby Power Rating — Output available with varying load for the duration of the interruption of the normal source power. Average power output is 70% of the standby power rating. Typical operation is 200 hours per year, with maximum expected usage of 500 hours per year.

Prime Power Rating — Output available with varying load for an unlimited time. Average power output is 70% of the prime power rating. Typical peak demand is 100% of prime rated kW with 10% overload capability for emergency use for a maximum of 1 hour in 12. Overload operation cannot exceed 25 hours per year.

Continuous Power Rating — Output available with non-varying load for an unlimited time. Average power output is 70-100% of the continuous power rating. Typical peak demand is 100% of continuous rated kW for 100% of operating hours.

Applicable Codes and Standards: AS1359, CSAC22.2 No100-04, UL142, UL489, UL869, UL2200, NFPA37, NFPA70, NFPA99, NFPA110, IBC, IEC60034-1, ISO 3046, ISO 8528, NEMA MG 1-22, NEMA MG 1-33, 2006/95/EC for Low Voltage, 2006/42/EC for Machinery, 2004/108/EC.

Fuel rates are based on fuel oil of 35° API [16° C (60° F)] gravity having an LHV of 42 780 kJ/kg (18,390 Btu/lb) when used at 29° C (85° F) and weighing 838.9 g/liter (7,001 lb/U.S. gal). Additional ratings may be available for specific customer requirements, contact your Caterpillar representative for details. For information regarding Low Sulfur fuel and Biodiesel capability, please consult your Cat dealer.

Cat Generator Sets

Diesel Ratings

60 Hz			
Model	Standby	Prime	Continuous
ekW			
900 rpm			
6CM20C	1037	979	979
8CM20C	1382	1306	1306
9CM20C	1555	1469	1469
3606	2000	1820	1650
3608	2660	2420	2200
3612	4000	3640	3300
3616	5320	4840	4400
720 rpm			
3606	1680	1525	1375
6CM25C	1920	1728	1728
3608	2200	2020	1830
8CM25C	2559	2304	2304
9CM25C	2880	2592	2592
3612	3360	3050	2750
3616	4400	4040	3660
12CM32C	6169	5820	5820
16CM32C	8226	7760	7760
600 rpm			
6CM32C	2880	2765	2765
8CM32C	3840	3686	3686
9CM32C	4320	4147	4147
514 rpm			
6CM43C	6111	5471	5471
7CM43C	7130	6383	6383
8CM43C	8148	7294	7294
9CM43C	9167	8206	8206
12CM43C	12 222	10 942	10 942
16CM43C	16 296	14 589	14 589

NOTE: All CM engines for land based application rated in accordance with WBII.

Rating Definitions:

Standby Power Rating — Output available with varying load for the duration of the interruption of the normal source power. Average power output is 70% of the standby power rating. Typical operation is 200 hours per year, with maximum expected usage of 500 hours per year.

Prime Power Rating — Output available with varying load for an unlimited time. Average power output is 70% of the prime power rating. Typical peak demand is 100% of prime rated kW with 10% overload capability for emergency use for a maximum of 1 hour in 12. Overload operation cannot exceed 25 hours per year.

Continuous Power Rating — Output available with non-varying load for an unlimited time. Average power output is 70-100% of the continuous power rating. Typical peak demand is 100% of continuous rated kW for 100% of operating hours.

Applicable Codes and Standards: AS1359, CSAC22.2 No100-04, UL142, UL489, UL869, UL2200, NFPA37, NFPA70, NFPA99, NFPA110, IBC, IEC60034-1, ISO 3046, ISO 8528, NEMA MG 1-22, NEMA MG 1-33, 2006/95/EC for Low Voltage, 2006/42/EC for Machinery, 2004/108/EC.

Fuel rates are based on fuel oil of 35° API [16° C (60° F)] gravity having an LHV of 42 780 kJ/kg (18,390 Btu/lb) when used at 29° C (85° F) and weighing 838.9 g/liter (7.001 lb/U.S. gal). Additional ratings may be available for specific customer requirements, contact your Caterpillar representative for details. For information regarding Low Sulfur fuel and Biodiesel capability, please consult your Cat dealer.

Cat Generator Sets

Diesel Ratings

50 Hz			
Model	rpm	Standby	Prime
		kVA	
3-Phase Output*			
DE9.5E3	1500	9.5	8.5
DE13.5E3	1500	13.5	12.5
DE18E3	1500	18	16.5
DE22E3	1500	22	20
DE33E0	1500	33	30
DE33E3	1500	33	30
DE50E0	1500	50	45
DE55E2	1500	55	50
DE65E0	1500	65	60
DE65E3	1500	65	60
DE88E0	1500	88	80
DE88E3	1500	88	80
DE110E2	1500	110	100
DE110E3	1500	110	100
DE165E0	1500	165	150
DE200E0	1500	200	180
DE220E0	1500	218	200
Single Phase Output**			
DE7.5E3S	1500	7.5	6.8
DE11E3S	1500	11	10
DE14E3S	1500	14	13
DE16E3S	1500	16.5	15
DE26E0S	1500	26	24
DE26E3S	1500	26	24
DE40E0S	1500	40	36
DE40E2S	1500	40	36
DE50E0S	1500	50	45
DE55E3S	1500	55	50
DE90E2S	1500	90	82
DE90E3S	1500	90	82

*All ratings at 0.8 pf.

**All ratings at 1.0 pf.

50 Hz			
Model	rpm	Standby	Prime
		kVA	
1500 rpm			
3406C	300	275	—
3406C	350	320	—
C13	400	350	—
C13	450	400	—
C15 ACERT	500	455	—
C15 ACERT	550	500	—
C18 ACERT	605	550	—
C18 ACERT	660	600	—
C18 ACERT	700	635	—
3412C	750	680	—
3412C	800	725	—
3412C	900	810	—
C32 ACERT	1100	1000	910
C32 ACERT	1250	1150	—
3512	1250	1150	1000
3512	1400	1275	1206
3512B	1500	1360	—
3512B	1600	1500	1320
3512B-HD	1750	1600	—
3512B-HD	1875	1700	1500
3516	2000	1825	1600
3516B	2250	2000	1750
3516B-HD	2500	2275	2000
3516C	2750	2500	—
C175-16	3000	2725	2500
C175-16	3100*	2825*	2600*
C175-20	4000	3600	3250

*Rating does not include package mounted radiator.

Rating Definitions:

Standby Power Rating — Output available with varying load for the duration of the interruption of the normal source power. Average power output is 70% of the standby power rating. Typical operation is 200 hours per year, with maximum expected usage of 500 hours per year.

Prime Power Rating — Output available with varying load for an unlimited time. Average power output is 70% of the prime power rating. Typical peak demand is 100% of prime rated kW with 10% overload capability for emergency use for a maximum of 1 hour in 12. Overload operation cannot exceed 25 hours per year.

Continuous Power Rating — Output available with non-varying load for an unlimited time. Average power output is 70-100% of the continuous power rating. Typical peak demand is 100% of continuous rated kW for 100% of operating hours.

Applicable Codes and Standards: AS1359, CSACC2.2 No100-04, UL142, UL489, UL869, UL2200, NFPA37, NFPA70, NFPA99, NFPA110, IBC, IEC60034-1, ISO 3046, ISO 8528, NEMA MG 1-22, NEMA MG 1-33, 2006/95/EC for Low Voltage, 2006/42/EC for Machinery, 2004/108/EC.

Fuel rates are based on fuel oil of 35° API [16° C (60° F)] gravity having an LHV of 42 780 kJ/kg (18,390 Btu/lb) when used at 29° C (85° F) and weighing 838.9 g/liter (7.001 lb/U.S. gal). Additional ratings may be available for specific customer requirements, contact your Caterpillar representative for details. For information regarding Low Sulfur fuel and Biodiesel capability, please consult your Cat dealer.

Cat Generator Sets

Diesel Ratings

50 Hz			
Model	Standby	Prime	Continuous
kVA			
1000 rpm			
6CM20C	1440	1368	1368
8CM20C	1920	1824	1824
9CM20C	2160	2052	2052
3606	2688	2425	2200
3608	3575	3250	2938
3612	5375	4850	4400
3616	7150	6500	5875
750 rpm			
3606	2163	1963	1775
6CM25C	2400	2160	2160
3608	2863	2600	2363
8CM25C	3199	2880	2880
9CM25C	3600	3240	3240
3612	4325	3925	3550
3616	5725	5200	4725
12CM32C	7712	7275	7275
16CM32C	10 282	9700	9700
600 rpm			
6CM32C	3600	3456	3456
8CM32C	4800	4608	4608
9CM32C	5400	5184	5184
500 rpm			
6CM43C	7639	6839	6839
7CM43C	8912	7978	7978
8CM43C	10 185	9118	9118
9CM43C	11 458	10 258	10 258
12CM43C	15 278	13 677	13 677
16CM43C	20 370	18 236	18 236

NOTE: All CM engines for land based application rated in accordance with WBII.

Rating Definitions:

Standby Power Rating — Output available with varying load for the duration of the interruption of the normal source power. Average power output is 70% of the standby power rating. Typical operation is 200 hours per year, with maximum expected usage of 500 hours per year.

Prime Power Rating — Output available with varying load for an unlimited time. Average power output is 70% of the prime power rating. Typical peak demand is 100% of prime rated kW with 10% overload capability for emergency use for a maximum of 1 hour in 12. Overload operation cannot exceed 25 hours per year.

Continuous Power Rating — Output available with non-varying load for an unlimited time. Average power output is 70-100% of the continuous power rating. Typical peak demand is 100% of continuous rated kW for 100% of operating hours.

Applicable Codes and Standards: AS1359, CSAC22.2 No100-04, UL142, UL489, UL869, UL2200, NFPA37, NFPA70, NFPA99, NFPA110, IBC, IEC60034-1, ISO 3046, ISO 8528, NEMA MG 1-22, NEMA MG 1-33, 2006/95/EC for Low Voltage, 2006/42/EC for Machinery, 2004/108/EC.

Fuel rates are based on fuel oil of 35° API [16° C (60° F)] gravity having an LHV of 42 780 kJ/kg (18,390 Btu/lb) when used at 29° C (85° F) and weighing 838.9 g/liter (7.001 lb/U.S. gal). Additional ratings may be available for specific customer requirements, contact your Caterpillar representative for details. For information regarding Low Sulfur fuel and Biodiesel capability, please consult your Cat dealer.

Cat Marine Engines

Propulsion Ratings

Engine Model	bkW Rating Range	bhp Rating Range
C280-16 DITA	4600-5650	6169-7577
C280-12 DITA	3460-4060	4640-5444
C280-8 DITA	2300-2710	3084-3634
C280-6 DITA	1730-2030	2320-2722
C175-16	2001-2550	2683-2907
3516C HD	1686-2525	2260-3386
3516C DITA	1230-2525	1650-3386
3516B HP DITA	2000-2237	2682-3000
3516B HD DITA	1398-2000	1875-2682
3516B DITA	1230-2237	1650-3000
3516 DITA	1195-1491	1603-2000
3512C HD	1118-1902	1500-2551
3512C DITA	955-1230	1340-1650
3512B HP DITA	1342-1678	1800-2250
3512B HD DITA	1118-1500	1500-2012
3512B DITA	820-1678	1100-2250
3512 DITA	900-1305	1207-1750
3508C DITA	578-820	775-1100
3508B HP DITA	895-1118	1200-1500
3508B DITA	578-1118	775-1500
3508 DITA	526-857	705-1150
C32 ACERT DITA	492-1417	660-1900
C18 ACERT DITA	339-847	454-1136
3406C	272-298	365-400
C12 DITA	254-448	340-600
C12 ACERT DITA	492-526	660-705
C9 ACERT DITA	375-423	503-567
C7 DITA	187-276	250-370
C7 ACERT DITA	339	455
3056 DITA	93-153	125-205

Generator Ratings

Engine Model	50 Hz ekW @ rpm	60 Hz ekW @ rpm
C280-16 DITA	4700/5200 @ 1000	4400/4840 @ 900
C280-12 DITA	3520/3880 @ 1000	3300/3640 @ 900
C280-8 DITA	2350/2600 @ 1000	2200/2420 @ 900
C280-6 DITA	1760/1940 @ 1000	1650/1820 @ 900
3516B DITA	1460/1600 @ 1500	1825 @ 1800
3516B DITA	1180 @ 1000	1285 @ 1200
3512C DITA	N/A	1550/1770 @ 1800
3512B DITA	965/1200 @ 1500	1070/1360 @ 1800
3512B DITA	880 @ 1000	1030 @ 1200
3508B DITA	630/800 @ 1500	715/910 @ 1800
3508B DITA	590 @ 1000	600 @ 1200
C32 ACERT DITTA	540/830 @ 1500	715/940 @ 1800
C18 ACERT DITA	275-450 @ 1500	340-550 @ 1800
C9 DIT	142-200 @ 1500	163-250 @ 1800
C7.1	92-150 @ 1500	106-200 @ 1800
C6.6 ACERT —	93-143 @ 1500	113-170 @ 1800
C4.4 DITA	36-99 @ 1500	42-118 @ 1800
C2.2 DIT	16/22.5 @ 1500	19.5/27 @ 1800
C1.5 DINA	10-11 @ 1500	12/13 @ 1800

For more information on IMO regulations and compliance contact:

- For IMO and U.S. EPA requirements see www.epa.gov/otaq/marine.htm
- For IMO and Canada compliance see regulation 108 at <http://laws-lois.justice.gc.ca/eng/regulations/SOR-2012-69/index.html>
- ABS guide “Notes on Prevention of Air Pollution from Ships,” or call ABS, Texas, phone: (281) 877-6306

For additional information on Cat Marine Power, see our new marine site: www.cat-marine.com

Cat Marine Engines

Auxiliary Ratings

Engine Model	50 Hz 1500 rpm bkW/bhp	50 Hz 1000 rpm bkW/bhp	60 Hz 1800 rpm bkW/bhp	60 Hz 1200 rpm bkW/bhp	60 Hz 900 rpm bkW/bhp
C280-16 DITA	—	4920-5420/ 6598-7268	—	—	4600-5060/ 6169-6785
C280-12 DITA	—	3700-4060/ 4962-5444	—	—	3460-3800/ 4640-5096
C280-8 DITA	—	2460-2710/ 3299-3634	—	—	2300-2530/ 3084-3393
C280-6 DITA	—	1850-2030/ 2481-2722	—	—	1730-1900/ 2320-2548
3516C DITA	—	—	1921-2368/ 2576-3176	—	—
3512C DITA	—	—	1432-1786/ 1920-2394	—	—
3516B DITA	1566-1717/ 2100-2303	1287/ 1726	1901/ 2549	1383/ 1855	—
3512B DITA	1020-1257/ 1368-1686	933/ 1251	1125-1424/ 1509-1910	1102/ 1478	—
3508B DITA	673-856/ 903-1148	649/ 870	760-968/ 1019-1298	682/ 915	—
3516 DITA	1355/ 1817	1100/ 1475	1511/ 2026	1230/ 1650	—
3512 DITA	—	—	—	955/ 1281	—
3508 DITA	—	446/ 598	—	599/ 804	—
C9 DITTA	162-215/ 217-288	—	189-269/ 253-361	—	—
C18 ACERT DITTA	—	—	547-601/ 733-806	—	—
C18 ACERT DITA	301-492/ 404-660	—	372-599/ 499-803	—	—
C32 ACERT DITA	590-874/ 791-1172	—	683-994/ 916-1333	—	—

For more information on
IMO regulations and compliance contact:

- For IMO and U.S. EPA requirements see www.epa.gov/otaq/marine.htm
- For IMO and Canada compliance see regulation 108 at <http://laws-lois.justice.gc.ca/eng/regulations/SOR-2012-69/index.html>
- ABS guide "Notes on Prevention of Air Pollution from Ships," or call ABS, Texas, phone: (281) 877-6306

For additional information on Cat Marine Power,
see our new marine site: www.cat-marine.com

Cat Industrial Diesel Applications

Meets U.S. EPA Tier 4 Final, EU Stage IIIB or Stage IV emission standards

Model	Type	"IND A"			"IND B"			"IND C"			"IND D"			"IND E"		
		bkW	bhp	rpm	bkW	bhp	rpm	bkW	bhp	rpm	bkW	bhp	rpm	bkW	bhp	rpm
C0.5	NA	—	—	—	—	—	—	8.2	11.0	2800*	—	—	—	—	—	—
		—	—	—	—	—	—	8.8	11.8	3000*	—	—	—	—	—	—
		—	—	—	—	—	—	10.2	13.7	3600*	—	—	—	—	—	—
C0.7	NA	—	—	—	—	—	—	12.2	16.4	2800*	—	—	—	—	—	—
		—	—	—	—	—	—	13.2	17.7	3000*	—	—	—	—	—	—
		—	—	—	—	—	—	15.3	20.5	3600*	—	—	—	—	—	—
C1.1	NA	—	—	—	—	—	—	13.7	18.4	2200*	—	—	—	—	—	—
		—	—	—	—	—	—	14.7	19.7	2200*	—	—	—	—	—	—
		—	—	—	—	—	—	16.1	21.6	2400*	—	—	—	—	—	—
		—	—	—	—	—	—	16.8	22.5	2800*	—	—	—	—	—	—
		—	—	—	—	—	—	17.2	23.0	2600*	—	—	—	—	—	—
		—	—	—	—	—	—	17.7	23.7	3000*	—	—	—	—	—	—
		—	—	—	—	—	—	18.4	24.7	2800	—	—	—	—	—	—
		—	—	—	—	—	—	19.7	26.4	3000*	—	—	—	—	—	—
		—	—	—	—	—	—	21.0	28.2	3400*	—	—	—	—	—	—
C1.5	NA	—	—	—	—	—	—	18.4	24.7	2100	—	—	—	—	—	—
		—	—	—	—	—	—	20.7	27.8	2200*	—	—	—	—	—	—
		—	—	—	—	—	—	23.4	31.4	2600*	—	—	—	—	—	—
		—	—	—	—	—	—	24.4	32.7	2800*	—	—	—	—	—	—
		—	—	—	—	—	—	25.1	33.7	3000*	—	—	—	—	—	—
C1.5	T	—	—	—	—	—	—	23.1	31.0	2200*	—	—	—	—	—	—
		—	—	—	—	—	—	25.2	33.8	2400	—	—	—	—	—	—
		—	—	—	—	—	—	27.0	36.2	2800	—	—	—	—	—	—
		—	—	—	—	—	—	27.3	36.6	2600*	—	—	—	—	—	—
		—	—	—	—	—	—	27.6	37.0	3000	—	—	—	—	—	—
		—	—	—	—	—	—	29.4	39.4	2800*	—	—	—	—	—	—
		—	—	—	—	—	—	30.0	40.2	3000*	—	—	—	—	—	—

Rating Conditions:

Diesel Engines — up to 7.1 liter

All rating conditions are based on ISO/TR14396, inlet air standard conditions with a total barometric pressure of 100 kPa (29.5 in Hg), with a vapor pressure of 1 kPa (0.295 in Hg), and 25° C (77° F). Performance measured using fuel to EPA specifications in 40 CFR Part 1065 and EU specifications in Directive 97/68/EC with a density of 0.845-0.850 kg/L @ 15° C (59° F) and fuel inlet temperature 40° C (104° F).

Diesel Engines — greater than 7.1 liter

All rating conditions are based on SAE J1995, inlet air standard conditions of 99 kPa (29.31 in Hg) dry barometer and 25° C (77° F) temperature. Performance measured using a standard fuel with fuel gravity of 35° API having a lower heating value of 42 780 kJ/kg (18,390 btu/lb) when used at 29° C (84.2° F) with a density of 838.9 g/L

Diesel Engine Rating Definitions

Explanation of Ratings A, B, C, D, and E:

- For an exact determination of the appropriate rating, contact your local Cat dealer. Engine rating obtained and presented in accordance with ISO 3046/1.

IND-A (Continuous)

- Continuous heavy-duty service where the engine is operated at maximum power and speed up to 100% of the time without interruption or load cycling.

IND-B

- For service where power and/or speed are cyclic (time at full load not to exceed 80%).

IND-C (Intermittent)

- Intermittent service where maximum power and/or speed are cyclic (time at full load not to exceed 50%).

IND-D

- For service where maximum power is required for periodic overloads (time at full load not to exceed 10% of the duty cycle).

IND-E

- For service where maximum power is required for a short time for initial starting or sudden overload. For emergency service where standard power is unavailable (time at full load not to exceed 5% of the duty cycle).

NA — Naturally Aspirated
 bhp — Brake horsepower
 bkW — Brake kilowatts

*Denotes rating is available in EU and other global regulated and non-regulated areas (Non-U.S.).

Cat Industrial Diesel Applications

Meets U.S. EPA Tier 4 Final, EU Stage IIIB or Stage IV emission standards

Model Type	"IND A"			"IND B"			"IND C"			"IND D"			"IND E"		
	bkW	bhp	rpm	bkW	bhp	rpm	bkW	bhp	rpm	bkW	bhp	rpm	bkW	bhp	rpm
C1.6 NA	—	—	—	—	—	—	24.6	33.0	2800*	—	—	—	—	—	—
	—	—	—	—	—	—	26.5	35.5	3000*	—	—	—	—	—	—
C1.7 NA	—	—	—	—	—	—	23.6	31.6	2400*	—	—	—	—	—	—
	—	—	—	—	—	—	26.1	35.0	2600*	—	—	—	—	—	—
C2.2 T	—	—	—	—	—	—	30.0	40.2	2800	—	—	—	—	—	—
	—	—	—	—	—	—	36.4	48.8	2800	—	—	—	—	—	—
C2.2 TA	—	—	—	—	—	—	36.4	48.8	2800	—	—	—	—	—	—
	—	—	—	—	—	—	50.0	67.05	2800	—	—	—	—	—	—
C3.4B T	—	—	—	—	—	—	45.0	60.3	2200	—	—	—	—	—	—
	—	—	—	—	—	—	47.0	63.0	2500	—	—	—	—	—	—
	—	—	—	—	—	—	50.0	67.0	2200	—	—	—	—	—	—
	—	—	—	—	—	—	55.4	74.3	2200 & 2500	—	—	—	—	—	—
C3.4B TA	—	—	—	—	—	—	63.0	84.5	2200	—	—	—	—	—	—
	—	—	—	—	—	—	66.0	88.5	2200 & 2500	—	—	—	—	—	—
	—	—	—	—	—	—	70.0	94.0	2200	—	—	—	—	—	—
	—	—	—	—	—	—	75.0	100.6	2200 & 2500	—	—	—	—	—	—
	—	—	—	—	—	—	—	—	—	83.0	111.3	2200	—	—	—
	—	—	—	—	—	—	—	—	—	86.0	115.3	2500	—	—	—
—	—	—	—	—	—	—	—	—	90.0	120.7	2200	—	—	—	

Rating Conditions:

Diesel Engines — up to 7.1 liter

All rating conditions are based on ISO/TR14396, inlet air standard conditions with a total barometric pressure of 100 kPa (**29.5 in Hg**), with a vapor pressure of 1 kPa (**0.295 in Hg**), and 25° C (**77° F**). Performance measured using fuel to EPA specifications in 40 CFR Part 1065 and EU specifications in Directive 97/68/EC with a density of 0.845-0.850 kg/L @ 15° C (**59° F**) and fuel inlet temperature 40° C (**104° F**).

Diesel Engines — greater than 7.1 liter

All rating conditions are based on SAE J1995, inlet air standard conditions of 99 kPa (**29.31 in Hg**) dry barometer and 25° C (**77° F**) temperature. Performance measured using a standard fuel with fuel gravity of 35° API having a lower heating value of 42 780 kJ/kg (**18,390 btu/lb**) when used at 29° C (**84.2° F**) with a density of 838.9 g/L.

Diesel Engine Rating Definitions

Explanation of Ratings A, B, C, D, and E:

- For an exact determination of the appropriate rating, contact your local Cat dealer. Engine rating obtained and presented in accordance with ISO 3046/1.

IND-A (Continuous)

- Continuous heavy-duty service where the engine is operated at maximum power and speed up to 100% of the time without interruption or load cycling.

IND-B

- For service where power and/or speed are cyclic (time at full load not to exceed 80%).

IND-C (Intermittent)

- Intermittent service where maximum power and/or speed are cyclic (time at full load not to exceed 50%).

IND-D

- For service where maximum power is required for periodic overloads (time at full load not to exceed 10% of the duty cycle).

IND-E

- For service where maximum power is required for a short time for initial starting or sudden overload. For emergency service where standard power is unavailable (time at full load not to exceed 5% of the duty cycle).

T — Turbocharged

NA — Naturally Aspirated

bhp — Brake horsepower

bkW — Brake kilowatts

*Denotes rating is available in EU and other global regulated and non-regulated areas (Non-U.S.).

Cat Industrial Diesel Applications

Meets U.S. EPA Tier 4 Final, EU Stage IIIB or Stage IV emission standards

Model	Type	"IND A"			"IND B"			"IND C"			"IND D"			"IND E"			
		bkW	bhp	rpm	bkW	bhp	rpm	bkW	bhp	rpm	bkW	bhp	rpm	bkW	bhp	rpm	
C4.4 ACERT	TA	—	—	—	—	—	—	—	70.0	93.9	2200	—	—	—	—	—	—
		—	—	—	—	—	—	—	74.4	99.8	2200	—	—	—	—	—	—
		—	—	—	—	—	—	—	82.0	109.9	2200	—	—	—	—	—	—
		—	—	—	—	—	—	—	85.9	115.2	2200	—	—	—	—	—	—
		—	—	—	—	—	—	—	91.0	122.0	2200	—	—	—	—	—	—
		—	—	—	—	—	—	—	92.6	124.2	2200	—	—	—	—	—	—
		—	—	—	—	—	—	—	97.9	131.3	2200	—	—	—	—	—	—
		—	—	—	—	—	—	—	102.1	136.9	2200	—	—	—	—	—	—
		—	—	—	—	—	—	—	106.0	142.1	2200	—	—	—	—	—	—
—	—	—	—	—	—	—	110.1	147.6	2200	—	—	—	—	—	—		
C4.4 ACERT	TTA	—	—	—	—	—	—	—	105.0	140.8	2200	—	—	—	—	—	—
		—	—	—	—	—	—	—	112.0	150.2	2200	—	—	—	—	—	—
		—	—	—	—	—	—	—	117.0	156.9	2200	—	—	—	—	—	—
		—	—	—	—	—	—	—	129.4	173.5	2200	—	—	—	—	—	—
C7.1 ACERT	TA	—	—	—	116	156	2200	—	—	—	—	—	—	—	—	—	
		—	—	—	129	173	2200	—	—	—	—	—	—	—	—	—	
		—	—	—	—	—	—	151.0	202.0	2200	—	—	—	—	—	—	—
C7.1 ACERT	TTA	—	—	—	151	202	2200	—	—	—	—	—	—	—	—	—	
		—	—	—	168	225	2200	—	—	—	—	—	—	—	—	—	
		—	—	—	—	—	—	186.0	249.0	2200	—	—	—	—	—	—	—
		—	—	—	—	—	—	205.0	275.0	2200	—	—	—	—	—	—	—
		—	—	—	—	—	—	225.0	302.0	2200	—	—	—	—	—	—	—

Rating Conditions:

Diesel Engines — up to 7.1 liter

All rating conditions are based on ISO/TR14396, inlet air standard conditions with a total barometric pressure of 100 kPa (29.5 in Hg), with a vapor pressure of 1 kPa (0.295 in Hg), and 25° C (77° F). Performance measured using fuel to EPA specifications in 40 CFR Part 1065 and EU specifications in Directive 97/68/EC with a density of 0.845-0.850 kg/L @ 15° C (59° F) and fuel inlet temperature 40° C (104° F).

Diesel Engines — greater than 7.1 liter

All rating conditions are based on SAE J1995, inlet air standard conditions of 99 kPa (29.31 in Hg) dry barometer and 25° C (77° F) temperature. Performance measured using a standard fuel with fuel gravity of 35° API having a lower heating value of 42 780 kJ/kg (18,390 btu/lb) when used at 29° C (84.2° F) with a density of 838.9 g/L.

Diesel Engine Rating Definitions

Explanation of Ratings A, B, C, D, and E:

- For an exact determination of the appropriate rating, contact your local Cat dealer. Engine rating obtained and presented in accordance with ISO 3046/1.

IND-A (Continuous)

- Continuous heavy-duty service where the engine is operated at maximum power and speed up to 100% of the time without interruption or load cycling.

IND-B

- For service where power and/or speed are cyclic (time at full load not to exceed 80%).

IND-C (Intermittent)

- Intermittent service where maximum power and/or speed are cyclic (time at full load not to exceed 50%).

IND-D

- For service where maximum power is required for periodic overloads (time at full load not to exceed 10% of the duty cycle).

IND-E

- For service where maximum power is required for a short time for initial starting or sudden overload. For emergency service where standard power is unavailable (time at full load not to exceed 5% of the duty cycle).

TA — Turbo Aftercooled
 TTA — Twin or Series Turbo Aftercooled
 bhp — Brake horsepower
 bkW — Brake kilowatts

Cat Industrial Diesel Applications

Meets U.S. EPA Tier 4 Final, EU Stage IIIB or Stage IV emission standards

Model	Type	"IND A"			"IND B"			"IND C"			"IND D"			"IND E"		
		bkW	bhp	rpm	bkW	bhp	rpm	bkW	bhp	rpm	bkW	bhp	rpm	bkW	bhp	rpm
C9.3 ACERT	TA	224	300	1800-2200	242	325	1800-2200	261	350	1800-2200	290	389	1800-2200	—	—	—
		—	—	—	—	—	—	—	—	—	298	400	2000	—	—	—
C13 ACERT	TA	287	385	1800-2100	309	415	1800-2100	328	440	1800-2100	354	475	1800-2100	388	520	1800-2100
C15 ACERT	TA	354	475	1800-2100	354	475	1800-2100	403	540	1800-2100	433	580	1800-2100	—	—	—
C18 ACERT	TA	429	575	1800-2000	447	600	1800-2000	470	630	1800-2000	—	—	—	—	—	—
C18 ACERT	TTA	—	—	—	—	—	—	563	755	1800	597	800	1800	—	—	—
C27 ACERT	TA	597	800	1800	653	875	1800	709	950	1800	783	1050	1800	—	—	—
C32 ACERT	TA	—	—	—	746	1000	1800	839	1125	1800	895	1200	1800	—	—	—

Rating Conditions:

Diesel Engines — up to 7.1 liter

All rating conditions are based on ISO/TR14396, inlet air standard conditions with a total barometric pressure of 100 kPa (**29.5 in Hg**), with a vapor pressure of 1 kPa (**0.295 in Hg**), and 25° C (**77° F**). Performance measured using fuel to EPA specifications in 40 CFR Part 1065 and EU specifications in Directive 97/68/EC with a density of 0.845-0.850 kg/L @ 15° C (**59° F**) and fuel inlet temperature 40° C (**104° F**).

Diesel Engines — greater than 7.1 liter

All rating conditions are based on SAE J1995, inlet air standard conditions of 99 kPa (**29.31 in Hg**) dry barometer and 25° C (**77° F**) temperature. Performance measured using a standard fuel with fuel gravity of 35° API having a lower heating value of 42 780 kJ/kg (**18,390 btu/lb**) when used at 29° C (**84.2° F**) with a density of 838.9 g/L.

Diesel Engine Rating Definitions

Explanation of Ratings A, B, C, D, and E:

- For an exact determination of the appropriate rating, contact your local Cat dealer. Engine rating obtained and presented in accordance with ISO 3046/1.

IND-A (Continuous)

- Continuous heavy-duty service where the engine is operated at maximum power and speed up to 100% of the time without interruption or load cycling.

IND-B

- For service where power and/or speed are cyclic (time at full load not to exceed 80%).

IND-C (Intermittent)

- Intermittent service where maximum power and/or speed are cyclic (time at full load not to exceed 50%).

IND-D

- For service where maximum power is required for periodic overloads (time at full load not to exceed 10% of the duty cycle).

IND-E

- For service where maximum power is required for a short time for initial starting or sudden overload. For emergency service where standard power is unavailable (time at full load not to exceed 5% of the duty cycle).

TA — Turbo Aftercooled
TTA — Twin or Series Turbo Aftercooled
bhp — Brake horsepower
bkW — Brake kilowatts

Cat Industrial Diesel Applications

Other Global Regulated and Non-Regulated Areas or with U.S. EPA/EU Transitional Provisions

Model	Type	"IND A"			"IND B"			"IND C"			"IND D"			"IND E"		
		bkW	bhp	rpm	bkW	bhp	rpm	bkW	bhp	rpm	bkW	bhp	rpm	bkW	bhp	rpm
C0.5	NA	—	—	—	—	—	—	8.2	11.0	2800	—	—	—	—	—	—
		—	—	—	—	—	—	8.8	11.8	3000	—	—	—	—	—	—
		—	—	—	—	—	—	10.2	13.7	3600	—	—	—	—	—	—
C0.7	NA	—	—	—	—	—	—	12.2	16.4	2800	—	—	—	—	—	—
		—	—	—	—	—	—	13.2	17.7	3000	—	—	—	—	—	—
		—	—	—	—	—	—	15.3	20.5	3600	—	—	—	—	—	—
C1.1	NA	—	—	—	—	—	—	13.7	18.4	2200	—	—	—	—	—	—
		—	—	—	—	—	—	14.7	19.7	2200	—	—	—	—	—	—
		—	—	—	—	—	—	16.1	21.6	2600	—	—	—	—	—	—
		—	—	—	—	—	—	16.8	22.5	2800	—	—	—	—	—	—
		—	—	—	—	—	—	17.2	23.0	2600	—	—	—	—	—	—
		—	—	—	—	—	—	17.7	23.7	3000	—	—	—	—	—	—
		—	—	—	—	—	—	18.5	24.8	2800	—	—	—	—	—	—
		—	—	—	—	—	—	19.7	26.4	3000	—	—	—	—	—	—
C1.5	NA	—	—	—	—	—	—	21.0	28.2	3400	—	—	—	—	—	—
		—	—	—	—	—	—	20.7	27.8	2200	—	—	—	—	—	—
		—	—	—	—	—	—	22.3	29.9	2400	—	—	—	—	—	—
		—	—	—	—	—	—	23.4	31.4	2600	—	—	—	—	—	—
		—	—	—	—	—	—	24.4	32.7	2800	—	—	—	—	—	—
C1.5	T	—	—	—	—	—	—	25.1	33.7	3000	—	—	—	—	—	—
		—	—	—	—	—	—	23.1	31.0	2200	—	—	—	—	—	—
		—	—	—	—	—	—	25.2	33.8	2400	—	—	—	—	—	—
		—	—	—	—	—	—	27.3	36.6	2600	—	—	—	—	—	—
		—	—	—	—	—	—	29.4	39.4	2800	—	—	—	—	—	—
C1.6	NA	—	—	—	—	—	—	30.0	40.2	3000	—	—	—	—	—	—
		—	—	—	—	—	—	24.6	33.0	2800	—	—	—	—	—	—
C1.7	NA	—	—	—	—	—	—	26.5	35.5	3000	—	—	—	—	—	—
		—	—	—	—	—	—	23.6	31.6	2400	—	—	—	—	—	—
		—	—	—	—	—	—	26.1	35.0	2600	—	—	—	—	—	—

Rating Conditions:

Diesel Engines — up to 7.1 liter

All rating conditions are based on ISO/TR14396, inlet air standard conditions with a total barometric pressure of 100 kPa (29.5 in Hg), with a vapor pressure of 1 kPa (0.295 in Hg), and 25° C (77° F). Performance measured using fuel to EPA specifications in 40 CFR Part 1065 and EU specifications in Directive 97/68/EC with a density of 0.845-0.850 kg/L @ 15° C (59° F) and fuel inlet temperature 40° C (104° F).

Diesel Engines — greater than 7.1 liter

All rating conditions are based on SAE J1995, inlet air standard conditions of 99 kPa (29.31 in Hg) dry barometer and 25° C (77° F) temperature. Performance measured using a standard fuel with fuel gravity of 35° API having a lower heating value of 42 780 kJ/kg (18,390 btu/lb) when used at 29° C (84.2° F) with a density of 838.9 g/L.

Diesel Engine Rating Definitions

Explanation of Ratings A, B, C, D, and E:

- For an exact determination of the appropriate rating, contact your local Cat dealer. Engine rating obtained and presented in accordance with ISO 3046/1.

IND-A (Continuous)

- Continuous heavy-duty service where the engine is operated at maximum power and speed up to 100% of the time without interruption or load cycling.

IND-B

- For service where power and/or speed are cyclic (time at full load not to exceed 80%).

IND-C (Intermittent)

- Intermittent service where maximum power and/or speed are cyclic (time at full load not to exceed 50%).

IND-D

- For service where maximum power is required for periodic overloads (time at full load not to exceed 10% of the duty cycle).

IND-E

- For service where maximum power is required for a short time for initial starting or sudden overload. For emergency service where standard power is unavailable (time at full load not to exceed 5% of the duty cycle).

NA — Naturally Aspirated
 T — Turbocharged
 bhp — Brake horsepower
 bkW — Brake kilowatts

Cat Industrial Diesel Applications

Other Global Regulated and Non-Regulated Areas, or U.S. EPA/EU Transitional Provisions

Model	Type	"IND A"			"IND B"			"IND C"			"IND D"			"IND E"		
		bkW	bhp	rpm	bkW	bhp	rpm	bkW	bhp	rpm	bkW	bhp	rpm	bkW	bhp	rpm
C2.2	NA	—	—	—	—	—	—	31.0	41.6	2200	—	—	—	—	—	—
		—	—	—	—	—	—	31.4	42.1	2600	—	—	—	—	—	—
		—	—	—	—	—	—	34.1	45.7	2400	—	—	—	—	—	—
		—	—	—	—	—	—	35.7	47.9	2600	—	—	—	—	—	—
		—	—	—	—	—	—	36.4	48.8	2800 & 3000	—	—	—	—	—	—
C2.2	T	—	—	—	—	—	—	36.3	48.7	2800	—	—	—	—	—	—
		—	—	—	—	—	—	40.0	53.3	2800	—	—	—	—	—	—
		—	—	—	—	—	—	43.0	57.7	2600	—	—	—	—	—	—
		—	—	—	—	—	—	44.7	60.0	2800	—	—	—	—	—	—
		—	—	—	—	—	—	45.5	61.0	3000	—	—	—	—	—	—
C2.2	TA	—	—	—	—	—	49.3	66.1	2800	—	—	—	—	—	—	
3054C	NA	—	—	—	—	—	—	52.0-64.0	69.7-85.8	2000-2400	—	—	—	—	—	—
		—	—	—	—	—	—	62.0-74.5	83.0-99.9	2000-2400	—	—	—	—	—	—
3054C	T	—	—	—	—	—	—	78.0-97.0	104.5-130	2000-2300	—	—	—	—	—	—
C4.4	NA	—	—	—	—	—	—	54.0	72.4	2200	—	—	—	—	—	—
		—	—	—	—	—	—	56.0	75.0	2200	—	—	—	—	—	—
C4.4	T	—	—	—	—	—	—	55.5-74.5	74.4-99.9	2200-2400	—	—	—	—	—	—
		—	—	—	—	—	—	68.0-83.0	91.2-111.3	2200-2400	—	—	—	—	—	—
C4.4	TA	—	—	—	—	—	—	61.5-74.5	82.5-99.0	2200	—	—	—	—	—	—
C4.4 ACERT	T	—	—	—	—	—	—	65.9-129.4	88.4-173.5	2200	—	—	—	—	—	—
C4.4 ACERT	TA	—	—	—	—	—	—				—	—	—	—	—	—

Rating Conditions:

Diesel Engines — up to 7.1 liter

All rating conditions are based on ISO/TR14396, inlet air standard conditions with a total barometric pressure of 100 kPa (29.5 in Hg), with a vapor pressure of 1 kPa (0.295 in Hg), and 25° C (77° F). Performance measured using fuel to EPA specifications in 40 CFR Part 1065 and EU specifications in Directive 97/68/EC with a density of 0.845-0.850 kg/L @ 15° C (59° F) and fuel inlet temperature 40° C (104° F).

Diesel Engines — greater than 7.1 liter

All rating conditions are based on SAE J1995, inlet air standard conditions of 99 kPa (29.31 in Hg) dry barometer and 25° C (77° F) temperature. Performance measured using a standard fuel with fuel gravity of 35° API having a lower heating value of 42 780 kJ/kg (18,390 btu/lb) when used at 29° C (84.2° F) with a density of 838.9 g/L.

Diesel Engine Rating Definitions

Explanation of Ratings A, B, C, D, and E:

- For an exact determination of the appropriate rating, contact your local Cat dealer. Engine rating obtained and presented in accordance with ISO 3046/1.

IND-A (Continuous)

- Continuous heavy-duty service where the engine is operated at maximum power and speed up to 100% of the time without interruption or load cycling.

IND-B

- For service where power and/or speed are cyclic (time at full load not to exceed 80%).

IND-C (Intermittent)

- Intermittent service where maximum power and/or speed are cyclic (time at full load not to exceed 50%).

IND-D

- For service where maximum power is required for periodic overloads (time at full load not to exceed 10% of the duty cycle).

IND-E

- For service where maximum power is required for a short time for initial starting or sudden overload. For emergency service where standard power is unavailable (time at full load not to exceed 5% of the duty cycle).

NA — Naturally Aspirated

T — Turbocharged

TA — Turbo Aftercooled

bhp — Brake horsepower

kW — Brake kilowatts

Cat Industrial Diesel Applications

Other Global Regulated and Non-Regulated Areas, or U.S. EPA/EU Transitional Provisions

Model	Type	"IND A"			"IND B"			"IND C"			"IND D"			"IND E"		
		bkW	bhp	rpm	bkW	bhp	rpm	bkW	bhp	rpm	bkW	bhp	rpm	bkW	bhp	rpm
C6.6 ACERT	TA*	—	—	—	—	—	—	89.0	119.0	2200	—	—	—	—	—	—
		—	—	—	—	—	—	116.5	156.2	2200	—	—	—	—	—	—
		—	—	—	—	—	—	129.0	173.0	2500	—	—	—	—	—	—
		—	—	—	—	—	—	129.4	173.5	2200	—	—	—	—	—	—
C7 ACERT	TA	—	—	—	168	225	1800-2200	186.0	250.0	1800-2200	224	300	2100-2200	—	—	—
		—	—	—	—	—	—	205.0	275.0	1800-2200	—	—	—	—	—	—
C7.1	TA	—	—	—	—	—	—	112.0	150.0	1950	—	—	—	—	—	—
		—	—	—	—	—	—	129.0	172.0	2200	—	—	—	—	—	—
		—	—	—	—	—	—	137.0	183.0	2200	—	—	—	—	—	—
		—	—	—	—	—	—	145.0	194.0	2200	—	—	—	—	—	—
		—	—	—	—	—	—	162.0	220.0	2200	—	—	—	—	—	—
C7.1 ACERT	TA	—	—	—	—	—	—	116	156	2200	—	—	—	—	—	—
		—	—	—	—	—	—	129	173	2200	—	—	—	—	—	—
		—	—	—	—	—	—	130	174	2500	—	—	—	—	—	—
		—	—	—	—	—	—	151	202	2200	—	—	—	—	—	—
		—	—	—	—	—	—	159	215	2200	—	—	—	—	—	—
		—	—	—	—	—	—	162	217	2200	—	—	—	—	—	—
		—	—	—	—	—	—	168	225	2200	—	—	—	—	—	—
		—	—	—	—	—	—	186	250	2200	—	—	—	—	—	—
—	—	—	—	—	—	205	275	2200	—	—	—	—	—	—		

*(Tier 4 Interim/Stage IIIA Equivalent) Available for Flex.

Rating Conditions:

Diesel Engines — up to 7.1 liter

All rating conditions are based on ISO/TR14396, inlet air standard conditions with a total barometric pressure of 100 kPa (**29.5 in Hg**), with a vapor pressure of 1 kPa (**0.295 in Hg**), and 25° C (**77° F**). Performance measured using fuel to EPA specifications in 40 CFR Part 1065 and EU specifications in Directive 97/68/EC with a density of 0.845-0.850 kg/L @ 15° C (**59° F**) and fuel inlet temperature 40° C (**104° F**).

Diesel Engines — greater than 7.1 liter

All rating conditions are based on SAE J1995, inlet air standard conditions of 99 kPa (**29.31 in Hg**) dry barometer and 25° C (**77° F**) temperature. Performance measured using a standard fuel with fuel gravity of 35° API having a lower heating value of 42 780 kJ/kg (**18,390 btu/lb**) when used at 29° C (**84.2° F**) with a density of 838.9 g/L.

Diesel Engine Rating Definitions

Explanation of Ratings A, B, C, D, and E:

- For an exact determination of the appropriate rating, contact your local Cat dealer. Engine rating obtained and presented in accordance with ISO 3046/1.

IND-A (Continuous)

- Continuous heavy-duty service where the engine is operated at maximum power and speed up to 100% of the time without interruption or load cycling.

IND-B

- For service where power and/or speed are cyclic (time at full load not to exceed 80%).

IND-C (Intermittent)

- Intermittent service where maximum power and/or speed are cyclic (time at full load not to exceed 50%).

IND-D

- For service where maximum power is required for periodic overloads (time at full load not to exceed 10% of the duty cycle).

IND-E

- For service where maximum power is required for a short time for initial starting or sudden overload. For emergency service where standard power is unavailable (time at full load not to exceed 5% of the duty cycle).

TA — Turbo Aftercooled
bhp — Brake horsepower
bkW — Brake kilowatts

Cat Industrial Diesel Applications

Other Global Regulated and Non-Regulated Areas

Model	Type	"IND A"			"IND B"			"IND C"			"IND D"			"IND E"		
		bkW	bhp	rpm	bkW	bhp	rpm	bkW	bhp	rpm	bkW	bhp	rpm	bkW	bhp	rpm
C9 ACERT	TA	205	275	1800-2200	223	300	1800-2200	242	325	1800-2200	280	375	1800-2200	—	—	—
		—	—	—	—	—	—	261	350	1800-2200	—	—	—	—	—	—
C11 ACERT	TA	242	325	1800-2100	261	350	1800-2100	287	385	1800-2100	313	420	1800-2100	336	450	1800-2100
3406C	TA	—	—	—	—	—	—	298	400	1800-2100	347	465	1800-2100	—	—	—
		—	—	—	—	—	—	343	460	2100	—	—	—	—	—	—
C13 ACERT	TA	287	385	1800-2100	310.0	415	1800-2100	328	440	1800-2100	354	475	1800-2100	388	520	1800-2100
C15 ACERT	TA	328	440	1800-2100	354.0	475	1800-2100	403	540	1800-2100	433	580	1800-2100	444	595	1800-2100
C18 ACERT	TA	429	575	1800-2100	447.5	600	1800-2100	470	630	1800-2100	—	—	—	—	—	—
		447	600	1800-1900	—	—	—	—	—	—	—	—	—	—	—	—
C18 ACERT	TTA	—	—	—	—	—	—	522	700	1800-2100	571	765	1800-2100	597	800	1800-2100
		—	—	—	—	—	—	563	755	1800-1900	597	800	1800-1900	—	—	—
C27 ACERT	TA	597	800	1800-2100	653.0	875	1800-2100	708	950	1800-2100	783	1050	1800-2100	858	1150	1800-2100
C32 ACERT	TA	—	—	—	708.0	950	1800-2100	839	1125	1800-2100	895	1200	1800-2100	1007	1350	1800-2100

Rating Conditions:

Diesel Engines — up to 7.1 liter

All rating conditions are based on ISO/TR14396, inlet air standard conditions with a total barometric pressure of 100 kPa (29.5 in Hg), with a vapor pressure of 1 kPa (0.295 in Hg), and 25° C (77° F). Performance measured using fuel to EPA specifications in 40 CFR Part 1065 and EU specifications in Directive 97/68/EC with a density of 0.845-0.850 kg/L @ 15° C (59° F) and fuel inlet temperature 40° C (104° F).

Diesel Engines — greater than 7.1 liter

All rating conditions are based on SAE J1995, inlet air standard conditions of 99 kPa (29.31 in Hg) dry barometer and 25° C (77° F) temperature. Performance measured using a standard fuel with fuel gravity of 35° API having a lower heating value of 42 780 kJ/kg (18,390 btu/lb) when used at 29° C (84.2° F) with a density of 838.9 g/L.

Diesel Engine Rating Definitions

Explanation of Ratings A, B, C, D, and E:

- For an exact determination of the appropriate rating, contact your local Cat dealer. Engine rating obtained and presented in accordance with ISO 3046/1.

IND-A (Continuous)

- Continuous heavy-duty service where the engine is operated at maximum power and speed up to 100% of the time without interruption or load cycling.

IND-B

- For service where power and/or speed are cyclic (time at full load not to exceed 80%).

IND-C (Intermittent)

- Intermittent service where maximum power and/or speed are cyclic (time at full load not to exceed 50%).

IND-D

- For service where maximum power is required for periodic overloads (time at full load not to exceed 10% of the duty cycle).

IND-E

- For service where maximum power is required for a short time for initial starting or sudden overload. For emergency service where standard power is unavailable (time at full load not to exceed 5% of the duty cycle).

TA — Turbo Aftercooled
TTA — Twin or Series Turbo Aftercooled
bhp — Brake horsepower
bkW — Brake kilowatts

Cat Industrial Diesel Applications
Other Global Regulated and Non-Regulated Areas

Model	Type	"IND A"			"IND B"			"IND C"			"IND D"			"IND E"		
		bkW	bhp	rpm	bkW	bhp	rpm	bkW	bhp	rpm	bkW	bhp	rpm	bkW	bhp	rpm
3508	TA	507	680	1200	—	—	—	612	820	1300	—	—	—	—	—	—
		578	775	1800	—	—	—	634	850	1800	—	—	—	—	—	—
		638	855	1800	—	—	—	746	1000	1800	—	—	—	—	—	—
3508B	TA	746	1000	1800	783	1050	1800	820	1100	1800	—	—	—	—	—	
3512	TA	761	1020	1200	—	—	—	858	1150	1300	—	—	—	—	—	
		955	1280	1800	—	—	—	1119	1500	1800	—	—	—	—	—	
3512B	TA	1119	1500	1800	1174	1575	1800	1231	1650	1800	—	—	—	—	—	
3512C	TA	1120	1500	1800	—	—	—	—	—	—	—	—	—	—	—	
3516	TA	1011	1355	1200	—	—	—	1242	1665	1300	—	—	—	—	—	
		1275	1710	1800	—	—	—	1492	2000	1800	—	—	—	—	—	
3516B	TA	1492	2000	1800	1566	2100	1800	1640	2200	1800	—	—	—	—	—	
		1490	1998	750	—	—	—	—	—	—	—	—	—	—	—	
		1560	2092	800	—	—	—	—	—	—	—	—	—	—	—	
		1730	2319	900	—	—	—	—	—	—	—	—	—	—	—	
3608	TA	1850	2481	1000	—	—	—	—	—	—	—	—	—	—	—	
		2080	2787	800	—	—	—	—	—	—	—	—	—	—	—	
		2300	3080	900	—	—	—	—	—	—	—	—	—	—	—	
		2460	3300	1000	—	—	—	—	—	—	—	—	—	—	—	
3612	TA	2980	3996	750	—	—	—	—	—	—	—	—	—	—	—	
		3120	4184	800	—	—	—	—	—	—	—	—	—	—	—	
		3460	4640	900	—	—	—	—	—	—	—	—	—	—	—	
		3700	4962	1000	—	—	—	—	—	—	—	—	—	—	—	
3616	TA	4160	5579	800	—	—	—	—	—	—	—	—	—	—	—	
		4600	6169	900	—	—	—	—	—	—	—	—	—	—	—	
		4920	6598	1000	—	—	—	—	—	—	—	—	—	—	—	

Rating Conditions:

Diesel Engines — up to 7.1 liter

All rating conditions are based on ISO/TR14396, inlet air standard conditions with a total barometric pressure of 100 kPa (29.5 in Hg), with a vapor pressure of 1 kPa (0.295 in Hg), and 25° C (77° F). Performance measured using fuel to EPA specifications in 40 CFR Part 1065 and EU specifications in Directive 97/68/EC with a density of 0.845-0.850 kg/L @ 15° C (59° F) and fuel inlet temperature 40° C (104° F).

Diesel Engines — greater than 7.1 liter

All rating conditions are based on SAE J1995, inlet air standard conditions of 99 kPa (29.31 in Hg) dry barometer and 25° C (77° F) temperature. Performance measured using a standard fuel with fuel gravity of 35° API having a lower heating value of 42 780 kJ/kg (18,390 btu/lb) when used at 29° C (84.2° F) with a density of 838.9 g/L.

Diesel Engine Rating Definitions

Explanation of Ratings A, B, C, D, and E:

- For an exact determination of the appropriate rating, contact your local Cat dealer. Engine rating obtained and presented in accordance with ISO 3046/1.

IND-A (Continuous)

- Continuous heavy-duty service where the engine is operated at maximum power and speed up to 100% of the time without interruption or load cycling.

IND-B

- For service where power and/or speed are cyclic (time at full load not to exceed 80%).

IND-C (Intermittent)

- Intermittent service where maximum power and/or speed are cyclic (time at full load not to exceed 50%).

IND-D

- For service where maximum power is required for periodic overloads (time at full load not to exceed 10% of the duty cycle).

IND-E

- For service where maximum power is required for a short time for initial starting or sudden overload. For emergency service where standard power is unavailable (time at full load not to exceed 5% of the duty cycle).

TA — Turbo Aftercooled
 bhp — Brake horsepower
 bkW — Brake kilowatts

Cat Industrial Diesel Applications

Cat Diesel Engines for Fire Pump Packages

Model	No. of Cylinders	1460 rpm		1500 rpm		1750 rpm		1900 rpm		2100 rpm		2200 rpm		2300 rpm	
		bkW	bhp	bkW	bhp	bkW	bhp	bkW	bhp	bkW	bhp	bkW	bhp	bkW	bhp
C18 ACERT* TA	6	—	—	—	—	597	800	597	800	597	800	—	—	—	—
C18 ACERT** TA	6	—	—	—	—	522	700	522	700	522	700	—	—	—	—
C18 ACERT*** TA	6	—	—	—	—	447	600	447	600	447	600	—	—	—	—
3406C*** TA	6	—	—	522	700	—	—	—	—	—	—	—	—	—	—
3406C Wet Manifolds*** TA	6	—	—	—	—	276	370	—	—	359	482	—	—	339	455
		—	—	—	—	343	460	—	—	—	—	—	—	—	—
		—	—	—	—	218	292	—	—	321	430	—	—	—	—
		—	—	—	—	313	420	—	—	—	—	—	—	—	—
3412C Wet Manifolds**** TA	12	—	—	—	—	476	638	551	739	551	739	—	—	—	—
3508**** TA	8	709	950	—	—	794	1065	—	—	—	—	—	—	—	—
3512**** TA	12	1066	1430	—	—	1193	1600	—	—	—	—	—	—	—	—
3516**** TA	16	1417	1900	—	—	1480	1985	—	—	—	—	—	—	—	—

*U.S. EPA Tier 2 Equivalent, FM Approved, UL Listed

**U.S. EPA Tier 3 Equivalent, FM Approved, UL Listed

***Non-EPA Certified, FM Approved, UL Listed

****Non-EPA Certified, Not FM Approved, Not UL Listed

TA — Turbo Aftercooled

Rating Definition:

Standby: Fire pump engine ratings represent the output which may be utilized to drive stationary fire pumps where the pumping equipment has been sized according to ULI and FM procedures.

Cat Oil and Gas Engines

Gas Industrial Ratings

Model	900 rpm		1000 rpm		1200 rpm		1400 rpm		1500 rpm		1600 rpm		1800 rpm		
	bkW	bhp	bkW	bhp	bkW	bhp	bkW	bhp	bkW	bhp	bkW	bhp	bkW	bhp	
G3304 NA	—	—	—	—	—	—	—	—	—	—	—	—	—	71	95
G3306 NA	—	—	—	—	—	—	—	—	—	—	—	—	—	108	145
G3306 TAA	—	—	—	—	—	—	—	—	—	—	—	—	—	157	211
G3306 TAA ¹	—	—	—	—	—	—	—	—	—	—	—	—	—	157	211
G3306 T	—	—	—	—	—	—	—	—	—	—	—	—	—	112	150
G3306 TA ¹	—	—	—	—	—	—	—	—	—	—	—	—	—	151	203
G3306 TA ¹	—	—	—	—	—	—	—	—	—	—	—	—	—	164	220
G3306B NA	—	—	—	—	—	—	—	—	—	—	—	—	—	108	145
G3306B TA ¹	—	—	—	—	—	—	—	—	—	—	—	—	—	153	205
G3406 NA	—	—	—	—	—	—	—	—	—	—	—	—	—	160	215
G3406 TA ¹	—	—	—	—	—	—	—	—	—	—	—	—	—	206	276
G3406 TA ¹	—	—	—	—	—	—	—	—	—	—	—	—	—	242	325
G3408 NA	—	—	—	—	—	—	—	—	—	—	—	—	—	190	255
G3408 TA ¹	—	—	—	—	—	—	—	—	—	249	332	—	—	—	—
G3408 TA ¹	—	—	—	—	—	—	—	—	—	—	—	—	—	298	400
G3408C LE ¹	—	—	—	—	—	—	—	—	—	—	—	—	—	317	425
G3412 TA ¹	—	—	—	—	—	—	—	—	—	373	500	—	—	—	—
G3412 TA ¹	—	—	—	—	—	—	—	—	—	—	—	—	—	448	600
G3412C LE ¹	—	—	—	—	—	—	—	—	—	—	—	—	—	475	637

¹ 54° C (130° F) water to aftercooler.

Ratings listed are for 25° C (77° F) ambient temperature, 152 m (500 ft) altitude, and pipeline quality gas.

- NA — Naturally Aspirated
- T — Turbocharged
- TA — Turbo Aftercooled
- TAA — Twin or Series Turbo Aftercooled
- LE — Low Emissions
- bhp — Brake horsepower
- bkW — Brake kilowatts

Rating Definition:

Continuous: Output available without varying load for an unlimited time. Continuous power in accordance with ISO 8528, ISO 3046-1, AS2789, DIN6271, and BS5514.

Cat Oil and Gas Engines

Gas Industrial Ratings

Model	720 rpm		750 rpm		1000 rpm		1200 rpm		1400 rpm		1800 rpm	
	bkW	bhp	bkW	bhp	bkW	bhp	bkW	bhp	bkW	bhp	bkW	bhp
CG137-8	—	—	—	—	—	—	—	—	—	—	298	400
CG137-12	—	—	—	—	—	—	—	—	—	—	447	600
G3508 TA ¹	—	—	—	—	—	—	391	524	—	—	—	—
G3508 LE ¹	—	—	—	—	—	—	—	—	500	670	—	—
G3508B LE ^{1,2,3}	—	—	—	—	—	—	—	—	515	690	—	—
G3512 TA ¹	—	—	—	—	—	—	589	790	—	—	—	—
G3512 LE ¹	—	—	—	—	—	—	642	860	—	—	—	—
G3512 LE ¹	—	—	—	—	—	—	—	—	749	1004	—	—
G3512B LE ^{1,2,3}	—	—	—	—	—	—	—	—	772	1035	—	—
G3516 NA	—	—	—	—	—	—	492	660	—	—	—	—
G3516 TA ¹	—	—	—	—	—	—	783	1050	—	—	—	—
G3516 LE ¹	—	—	—	—	—	—	858	1150	—	—	—	—
G3516 LE ¹	—	—	—	—	—	—	—	—	1000	1340	—	—
G3516B LE ^{1,2,3}	—	—	—	—	—	—	—	—	1029	1380	—	—
G3520B LE ^{1,2,3}	—	—	—	—	—	—	1104	1480	—	—	—	—
G3520B LE ^{1,2,3}	—	—	—	—	—	—	—	—	1286	1725	—	—
G3606 LE ^{1,2,4}	—	—	—	—	1324	1775	—	—	—	—	—	—
G3606 LE ^{4,6}	—	—	—	—	1368	1835	—	—	—	—	—	—
G3606 LE ^{4,5}	—	—	—	—	1413	1895	—	—	—	—	—	—
G3606 A4	—	—	—	—	1398-1499	1875-2010	—	—	—	—	—	—
G3608 LE ^{1,2,4}	—	—	—	—	1767	2370	—	—	—	—	—	—
G3608 LE ^{4,6}	—	—	—	—	1823	2445	—	—	—	—	—	—
G3608 LE ^{4,5}	—	—	—	—	1879	2520	—	—	—	—	—	—
G3608 A4	—	—	—	—	1864-1995	2500-2675	—	—	—	—	—	—
G3612 LE ^{1,2,4}	—	—	—	—	2647	3550	—	—	—	—	—	—
G3612 LE ^{4,6}	—	—	—	—	2733	3665	—	—	—	—	—	—
G3612 LE ^{4,5}	—	—	—	—	2822	3785	—	—	—	—	—	—
G3612 A4	—	—	—	—	2796-2983	3750-4000	—	—	—	—	—	—
G3616 LE ^{1,2,4}	—	—	—	—	3531	4735	—	—	—	—	—	—
G3616 LE ^{4,6}	—	—	—	—	3647	4890	—	—	—	—	—	—
G3616 LE ^{4,5}	—	—	—	—	3762	5045	—	—	—	—	—	—
G3616 A4	—	—	—	—	3729-3990	5000-5350	—	—	—	—	—	—
G12CM34 TA	5040	6759	5040	6759	—	—	—	—	—	—	—	—
G16CM34 TA	6720	9012	6720	9012	—	—	—	—	—	—	—	—
G20CM34 TA	10 000	13,410	10 000	13,410	—	—	—	—	—	—	—	—

¹ 54° C (130° F) water to aftercooler.

² 250 mg/N·m³ dry No_x NTE emissions (corrected to 5% O₂).

³ 500 mg/N·m³ dry No_x NTE emissions (corrected to 5% O₂).

⁴ 350 mg/N·m³ dry No_x NTE emissions (corrected to 5% O₂).

⁵ 32° C (90° F) aftercooler water and 88° C (190° F) jacket water.

⁶ 43° C (109° F) aftercooler water and 88° C (190° F) jacket water.

Ratings listed are for 25° C (77° F) ambient temperature, 152 m (500 ft) altitude, and pipeline quality gas.

NA — Naturally Aspirated

TA — Turbo Aftercooled

LE — Low Emissions

bhp — Brake horsepower

bkW — Brake kilowatts

Rating Definition:

Continuous: Output available without varying load for an unlimited time. Continuous power in accordance with ISO 8528, ISO 3046-1, AS2789, DIN6271, and BS5514.

CM Power Generation Onshore

Emissions according to WB2

CM Model	Fuel Type	Output Range		Speed	Frequency	Bore x Stroke		Fuel Efficiency		Crude Oil/ Heavy Fuel Operation at COP
		kW	hp	rpm		mm	in	g/kWh	MJ/kWh	
6CM20C	Diesel	1020	1368	900	60	200 x 300	7.9 x 11.8	189	8.07	x
6CM20C	Diesel	1140	1529	1000	50	200 x 300	7.9 x 11.8	190	8.11	x
8CM20C	Diesel	1360	1824	900	60	200 x 300	7.9 x 11.8	189	8.07	x
8CM20C	Diesel	1520	2038	1000	50	200 x 300	7.9 x 11.8	190	8.11	x
9CM20C	Diesel	1530	2052	900	60	200 x 300	7.9 x 11.8	189	8.07	x
9CM20C	Diesel	1710	2293	1000	50	200 x 300	7.9 x 11.8	190	8.11	x
6CM25C	Diesel	1800	2414	720	60	255 x 400	10 x 15.7	185	7.90	x
6CM25C	Diesel	1800	2414	750	50	255 x 400	10 x 15.7	185	7.90	x
8CM25C	Diesel	2400	3218	720	60	255 x 400	10 x 15.7	185	7.90	x
8CM25C	Diesel	2400	3218	750	50	255 x 400	10 x 15.7	185	7.90	x
9CM25C	Diesel	2700	3621	720	60	255 x 400	10 x 15.7	185	7.90	x
9CM25C	Diesel	2700	3621	750	50	255 x 400	10 x 15.7	185	7.90	x
6CM32E	Diesel	3000	4023	720	60	320 x 480	12.6 x 18.9	179	7.64	x
6CM32E	Diesel	3000	4023	750	50	320 x 480	12.6 x 18.9	179	7.64	x
8CM32E	Diesel	4000	5364	720	60	320 x 480	12.6 x 18.9	179	7.64	x
8CM32E	Diesel	4000	5364	750	50	320 x 480	12.6 x 18.9	179	7.64	x
9CM32E	Diesel	4500	6035	720	60	320 x 480	12.6 x 18.9	179	7.64	x
9CM32E	Diesel	4500	6035	750	50	320 x 480	12.6 x 18.9	179	7.64	x
12CM32C	Diesel	6000	8046	720	60	320 x 460	12.6 x 18.1	177	7.56	x
12CM32C	Diesel	6000	8046	750	50	320 x 460	12.6 x 18.1	178	7.60	x
16CM32C	Diesel	8000	10,728	720	60	320 x 460	12.6 x 18.1	177	7.56	x
16CM32C	Diesel	8000	10,728	750	50	320 x 460	12.6 x 18.1	178	7.60	x
6CM34DF	Dual Fuel	3000	4023	720	60	340 x 460	13.4 x 18.1	188	7.71*	x
6CM34DF	Dual Fuel	3000	4023	750	50	340 x 460	13.4 x 18.1	188	7.71*	x
8CM34DF	Dual Fuel	4000	5364	720	60	340 x 460	13.4 x 18.1	188	7.71*	x
8CM34DF	Dual Fuel	4000	5364	750	50	340 x 460	13.4 x 18.1	188	7.71*	x
9CM34DF	Dual Fuel	4500	6035	720	60	340 x 460	13.4 x 18.1	188	7.71*	x
9CM34DF	Dual Fuel	4500	6035	750	50	340 x 460	13.4 x 18.1	188	7.71*	x
6CM43C	Diesel	5640	7563	514	60	430 x 610	16.9 x 24	174	7.43	x
6CM43C	Diesel	5640	7563	500	50	430 x 610	16.9 x 24	174	7.43	x
7CM43C	Diesel	6580	8824	514	60	430 x 610	16.9 x 24	174	7.43	x
7CM43C	Diesel	6580	8824	500	50	430 x 610	16.9 x 24	174	7.43	x

*Heat rate (MJ/kWh) for gaseous fuel.

NOTES:

- Ratings: Continuous power based on ISO 3046-1 standard reference conditions.
- Power output: May require adjustment for values other than ISO 3046-1 standard reference conditions.
- Fuel as specified per ISO 8217. Limiting Caterpillar specification for fuel is VD8738 for crude oil operation at continuous power operation (COP).
- Fuel consumption: Based on ISO 3046-1 standard reference conditions of 25° C (77° F) and 100 kPa (29.61 in Hg), including one engine-driven lube oil pump, with 5% tolerance and LCV = 42 700 kJ/kg (18,358 Btu/lb).
- Dual Fuel (DF) engines: Specific fuel consumption (g/kWh) for liquid fuel; heat rate MJ/kWh for gaseous fuel.
- Generator efficiency: Efficiency of 97.0% (96.0% for complete CM20 and CM25 model range, and for 6CM32, 8CM32, 9CM32) based on power factor 0.8 with medium voltage class generator; actual efficiency will depend on generator selection.
- Crude oil operation only at continuous power generation.

CM Power Generation Onshore

Emissions according to WB2

CM Model	Fuel Type	Output Range		Speed	Frequency	Bore x Stroke		Fuel Efficiency		Crude Oil/ Heavy Fuel Operation at COP
		kW	hp	rpm		mm	in	g/kWh	MJ/kWh	
8CM43C	Diesel	7520	10,084	514	60	430 x 610	16.9 x 24	174	7.43	x
8CM43C	Diesel	7520	10,084	500	50	430 x 610	16.9 x 24	174	7.43	x
9CM43C	Diesel	8460	11,345	514	60	430 x 610	16.9 x 24	174	7.43	x
9CM43C	Diesel	8460	11,345	500	50	430 x 610	16.9 x 24	174	7.43	x
12CM43C	Diesel	11 280	15,127	514	60	430 x 610	16.9 x 24	173	7.39	x
12CM43C	Diesel	11 280	15,127	500	50	430 x 610	16.9 x 24	173	7.39	x
16CM43C	Diesel	15 040	20,169	514	60	430 x 610	16.9 x 24	173	7.39	x
16CM43C	Diesel	15 040	20,169	500	50	430 x 610	16.9 x 24	173	7.39	x
6CM46DF	Dual Fuel	5400	7241	514	60	460 x 610	18.1 x 24	186	7.27*	x
6CM46DF	Dual Fuel	5400	7241	500	50	460 x 610	18.1 x 24	186	7.27*	x
7CM46DF	Dual Fuel	6300	8448	514	60	460 x 610	18.1 x 24	186	7.27*	x
7CM46DF	Dual Fuel	6300	8448	500	50	460 x 610	18.1 x 24	186	7.27*	x
8CM46DF	Dual Fuel	7200	9655	514	60	460 x 610	18.1 x 24	186	7.27*	x
8CM46DF	Dual Fuel	7200	9655	500	50	460 x 610	18.1 x 24	186	7.27*	x
9CM46DF	Dual Fuel	8100	10,862	514	60	460 x 610	18.1 x 24	186	7.27*	x
9CM46DF	Dual Fuel	8100	10,862	500	50	460 x 610	18.1 x 24	186	7.27*	x
12CM46DF	Dual Fuel	10 800	14,483	514	60	460 x 610	18.1 x 24	184	7.27*	x
12CM46DF	Dual Fuel	10 800	14,483	500	50	460 x 610	18.1 x 24	184	7.27*	x
16CM46DF	Dual Fuel	14 400	19,310	514	60	460 x 610	18.1 x 24	184	7.27*	x
16CM46DF	Dual Fuel	14 400	19,310	500	50	460 x 610	18.1 x 24	184	7.27*	x

Onshore only:

G16CM34	Natural Gas	6720	9012	720	60	340 x 420	13.4 x 16.5	N/A	7.53	
G16CM34	Natural Gas	6720	9012	750	50	340 x 420	13.4 x 16.5	N/A	7.83	
G20CM34	Natural Gas	10 000	13,410	720	60	340 x 420	13.4 x 16.5	N/A	7.22	
G20CM34	Natural Gas	10 000	13,410	750	50	340 x 420	13.4 x 16.5	N/A	7.26	

*Heat rate (MJ/kWh) for gaseous fuel.

NOTES:

- Ratings: Continuous power based on ISO 3046-1 standard reference conditions.
- Power output: May require adjustment for values other than ISO 3046-1 standard reference conditions.
- Fuel as specified per ISO 8217. Limiting Caterpillar specification for fuel is VD8738 for crude oil operation at continuous power operation (COP).
- Fuel consumption: Based on ISO 3046-1 standard reference conditions of 25° C (77° F) and 100 kPa (29.61 in Hg), including one engine-driven lube oil pump, with 5% tolerance and LCV = 42 700 kJ/kg (18,358 Btu/lb).
- Dual Fuel (DF) engines: Specific fuel consumption (g/kWh) for liquid fuel; heat rate MJ/kWh for gaseous fuel.
- Generator efficiency: Efficiency of 97.0% (96.0% for complete CM20 and CM25 model range, and for 6CM32, 8CM32, 9CM32) based on power factor 0.8 with medium voltage class generator; actual efficiency will depend on generator selection.
- Crude oil operation only at continuous power generation.

CM Pump Application

Emissions according to WB2

CM Model	Fuel Type	Output Range		Speed	Minimum Speed	Bore x Stroke		Fuel Efficiency		Crude Oil/ Heavy Fuel Operation at COP
		kW	hp	rpm	rpm	mm	in	g/kWh	MJ/kWh	
6CM20C	Diesel	1140	1529	1000	300	200 x 300	7.9 x 11.8	190	8.11	x
8CM20C	Diesel	1520	2038	1000	300	200 x 300	7.9 x 11.8	190	8.11	x
9CM20C	Diesel	1710	2293	1000	300	200 x 300	7.9 x 11.8	190	8.11	x
6CM25C	Diesel	1800	2414	750	250	250 x 400	9.8 x 15.7	185	7.90	x
8CM25C	Diesel	2400	3218	750	240	250 x 400	9.8 x 15.7	185	7.90	x
9CM25C	Diesel	2700	3621	750	250	250 x 400	9.8 x 15.7	185	7.90	x
6CM32C	Diesel	2700	3621	600	360	320 x 480	12.6 x 18.9	185	7.90	x
8CM32C	Diesel	3600	4828	600	360	320 x 480	12.6 x 18.9	185	7.90	x
9CM32C	Diesel	4050	5431	600	360	320 x 480	12.6 x 18.9	185	7.90	x

Gas Engines:

G12CM34	Natural gas	4575	6135	750	450	340 x 420	13.4 x 16.5	N/A	7.92	
G16CM34	Natural gas	6100	8180	750	450	340 x 420	13.4 x 16.5	N/A	7.94	

*Heat rate (MJ/kWh) for gaseous fuel.

NOTES:

- Ratings: Continuous power based on ISO 3046-1 standard reference conditions.
- Power output: May require adjustment for values other than ISO 3046-1 standard reference conditions.
- Fuel as specified per ISO 8217. Limiting Caterpillar specification for fuel is VD8738 for crude oil operation at continuous power operation (COP).
- Fuel consumption: Based on ISO 3046-1 standard reference conditions of 25° C (77° F) and 100 kPa (29.61 in Hg), including one engine-driven lube oil pump, with 5% tolerance and LCV = 42 700 kJ/kg (18,358 Btu/lb).
- Dual Fuel (DF) engines: Specific fuel consumption (g/kWh) for liquid fuel; heat rate MJ/kWh for gaseous fuel.
- Generator efficiency: Efficiency of 97.0% (96.0% for complete CM20 and CM25 model range, and for 6CM32, 8CM32, 9CM32) based on power factor 0.8 with medium voltage class generator; actual efficiency will depend on generator selection.
- Crude oil operation only at continuous power generation.

Engines

Cat Oil and Gas Engines

- Offshore Power Module Ratings
- Land Rig Power Module Ratings

Cat Oil and Gas Engines

Offshore Power Module Ratings

Model	L with Base		W of Base		H with Base		Approximate Weight with Base	
	m	ft	mm	in	mm	in	kg	lb
3508B	4.03	13'3"	1784	70	2048	80	12 475	27,503
3512B	4.84	15'11"	1988	78	2207	86	14 975	33,014
3512C	5.45	17'11"	1827	71	2315	91	14 975	33,300
3516B	6.09	20'6"	2474	84	2214	87	18 000	41,400

Land Rig Power Module Ratings

Model	L Bases Available*		W of Base		Radiator Height with Base		Approximate Weight with Base	
	m	ft	mm	in	mm	in	kg	lb
3508	7.85	25'9"	2385	94	2779	109.0	14 443	31,843
3508B	4.99	16'4"	2319	91	2596	102.0	15 352	33,846
3512	7.85	25'9"	2385	94	2936	116.0	15 714	34,644
3512B	6.05	19'10"	2318	91	2659	104.7	14 000	30,864
3512C	6.05	19'10"	2318	91	2659	104.7	14 453	31,864
3516	7.85	25'9"	2385	94	2497	98.3	18 340	40,433
3516B	7.85	25'9"	2385	94	2520	99.0	18 810	41,469

*9.37 m (30'9") and 12.4 m (40'9") bases also available for all models except 3508B.

Cat Oil and Gas Engines

Electric Drive Engine Ratings for SCR and DC Powered Rigs

Model	No. Cyl.	60 Hz								50 Hz					
		720 rpm		900 rpm		1200 rpm		1800 rpm		750 rpm		1000 rpm		1500 rpm	
		bkW	bhp	bkW	bhp	bkW	bhp	bkW	bhp	bkW	bhp	bkW	bhp	bkW	bhp
3508	V-8	—	—	—	—	641	860	—	—	—	—	—	—	—	—
3508B	V-8	—	—	—	—	682	915	—	—	—	—	—	—	880	1180
3508C	V-8	—	—	—	—	682	915	—	—	—	—	—	—	—	—
3512	V-12	—	—	—	—	708-1070	950-1435	—	—	—	—	830-890	1113-1194	1090	1462
3512B		—	—	—	—	1102	1478	—	—	—	—	933	1251	1257-1310	1686-1757
3512C	V-12	—	—	—	—	1102	1478	—	—	—	—	—	—	—	—
3512C HD	V-12	—	—	—	—	1305	1750	—	—	—	—	—	—	1310	1757
3516	V-16	—	—	—	—	1345	1804	—	—	—	—	1200	1609	—	—
3516B	V-16	—	—	—	—	1383-1717	1855-2303	—	—	—	—	—	—	—	—
3516B HD	V-16	—	—	—	—	1603	2150	—	—	—	—	—	—	—	—
3516C HD	V-16	—	—	—	—	1383	1855	—	—	—	—	—	—	—	—
3516C HD	V-16	—	—	—	—	1603	2150	—	—	—	—	—	—	—	—
C175-16	V-16	—	—	—	—	1930	2586	—	—	—	—	—	—	—	—

4

bhp — Brake horsepower
 bkW — Brake kilowatts

Requires Separate Circuit Aftercooling (SCAC), without fan power, when emissions compliant.

NOTE: For specific emission standards per model and rating, please see pages 4-19 through 4-20.

Engines

Cat Oil and Gas Engines

- Mechanical Drill Rig Ratings
- Fracturing/Acidizing/Cementing Ratings

Cat Oil and Gas Engines

Mechanical Drill Rig Ratings

Model	Pumping and Drilling Ratings (B Level)			
	No. Cyl.	rpm	bkW	bhp
C15 ACERT	I-6	1800-2100	354	475
C18 ACERT	I-6	2100	447	600
C27 ACERT	V-12	1800-2100	652	875
C32 ACERT	V-12	1800-2100	708	950
3508	V-8	1200	567	760
3508B	V-8	1200	671	900
3508B	V-8	1200	567	760
3512	V-12	1200	932	1250
3512C HD	V-12	1200	1100	1475

bhp — Brake horsepower
 bkW — Brake kilowatts

Fracturing/Acidizing/Cementing Ratings

Dry Manifolds (E Level)			
Model	bkW	bhp	rpm
C11 ACERT	336	450	2100
C13 ACERT	388	520	2100
C15 ACERT	444	595	2100
C18 ACERT	597	800	2100
C32 ACERT	913-1119	1225-1500	2100
3512B	1491	2000	1900
3512B	1603	2150	1900
3512B	1678	2250	1900
3512C HD	1603	2150	1900
3512C HD	1678	2250	1900
3512C HD	1752	2350	1900
3512C HD	1864	2500	1900
3512E	1678	2250	1800
3512E	1864	2500	1800
3516C HD	2237	3000	1900
3516C HD	2349	3150	1900
3516C HD	2461	3300	1900

Water Cooled Manifolds (E Level)			
Model	bkW	bhp	rpm
C32 ACERT	913	1225	2100

bhp — Brake horsepower
 bkW — Brake kilowatts

E Rating Level — fracturing.

Rating Definitions:

The horsepower and speed capability of the engine which can be used to power high pressure well servicing equipment.

NOTE: For a transmission match, consult your transmission supplier.

- Cat Railway Power
- Locomotive Traction Engine Ratings
 - Auxiliary Electric (Head End) Power Engine Ratings
 - Maintenance of Way Engine Ratings

Cat Railway Power

Locomotive Traction Engine Ratings

Model	Low Rating		High Rating		Rated Speed	Emissions
	bkW	bhp	bkW	bhp	rpm	Tier
C9.3 ACERT	205	275	280	375	1800-2200	Tier 4 Interim, Stage IIIB Equivalent
C13 ACERT	287	385	388	520	1800-2100	Tier 4 Interim, Stage IIIB Equivalent
C15 ACERT	328	440	444	595	1800-2100	Tier 4 Interim, Stage IIIB Equivalent
C18 ACERT	429	575	597	800	1800-2100	Tier 4 Interim, Stage IIIB Equivalent
C27 ACERT	597	800	858	1150	1800-2100	Stage IIIA, IIIB Equivalent
C32 ACERT	708	950	1007	1350	1800-2100	Tier 2, UIC2, Stage IIIB Equivalent
3508	503	675	1000	1341	1300-1800	Tier 3, Stage IIIA Equivalent
3512*	746	1000	1700	2280	1300-1800	Tier 3, Stage IIIA, IIIB Equivalent
3516	1200	1600	2240	3004	1300-1800	Tier 2, Stage IIIA Equivalent
G3516B**	895	1200	1104	1480	1500	—
C175-16 ACERT*	2500	3351	2800	3620	1800	Stage IIIA, IIIB Equivalent

*For EU Stage IIIB Equivalent availability contact your Cat dealer.

**For gas engine product offerings contact your Cat dealer.

Auxiliary Electric (Head End) Power Engine Ratings

Model	Rating	Power	Emissions
	Hz	ekW	Tier
C15 ACERT	50	292	Stage II Equivalent
C15 ACERT	50	328	Stage II Equivalent
C15 ACERT	50	364	Stage II Equivalent
C15 ACERT	50	400	Stage II Equivalent
C15 ACERT	60	320	Tier 3 Equivalent
C15 ACERT	60	365	Tier 3 Equivalent
C15 ACERT	60	410	Tier 3 Equivalent
C15 ACERT	60	455	Tier 2 and Tier 4 Interim Equivalent
C18 ACERT	50	400	Stage II Equivalent
C18 ACERT	50	436	Stage II Equivalent
C18 ACERT	50	508	Stage II Equivalent
C18 ACERT	50	573	Stage II Equivalent
C18 ACERT	60	500	Tier 2 Equivalent
C18 ACERT	60	545	Tier 2 Equivalent
C27 ACERT	60	590	Tier 2 Equivalent
C27 ACERT	60	635	Tier 2 Equivalent
C27 ACERT	60	680	Tier 2 Equivalent
C27 ACERT	60	725	Tier 2 and Tier 4 Interim Equivalent

All 60 Hz ratings are U.S. EPA emission certified (non-road mobile standards).

All 50 Hz ratings are EU emission certified (non-road mobile standards).

Maintenance of Way Engine Ratings

Please refer to pages 4-19 through 4-27 Cat Industrial Diesel Applications for all Cat Railway Power Maintenance of Way Engine applications.

FOREST PRODUCTS

CONTENTS

HARVESTING

Track Harvesters	
Sustainability	5-3
Features	5-3
Specifications	5-5
Dimensions	5-7
Shipping Dimensions	5-8
Range Diagrams	5-10
Track Feller Bunchers	
Features	5-13
Specifications	5-14
Shipping Dimensions	5-16
Range Diagrams	5-19
Wheel Feller Bunchers	
Features	5-21
Specifications	5-21
Dimensions	5-22
Felling Heads	
Specifications	5-24
SATCO Directional Felling Heads	
Features	5-25
Specifications	5-26
Harvester Heads	
Application	5-27
Features	5-27
Specifications	5-27
Dimensions	5-28
SATCO Processing Heads	
Features	5-29
Specifications	5-30

WOOD EXTRACTION

Wheel Skidders	
Features	5-37
Specifications	5-38
Dimensions	5-41
Lift Charts	5-42
Grapple Dimensions	5-44
Track Skidders	
Introduction	5-45
Features	5-45
Specifications	5-46
Shoe Selection and Ground Pressure	5-47
Winch Specifications	5-47
Dimensions	5-48
Drawbar Pull	5-50
Grapple Specifications	5-51
Forwarders	
Sustainability	5-53
Features	5-53
Specifications	5-53
Dimensions	5-55
Lift Capacities	5-56

PROCESSING/LOADING

Forest Machines	
Introduction	5-57
Features	5-57
Specifications	5-58
Working Ranges	5-62
Shipping Dimensions	5-67
Trailer Mount Knuckleboom Loaders	
Features	5-71
Specifications	5-71
Dimensions	5-72
Lift and Range Diagrams	5-73

MILLYARDS

Stationary Mount Knuckleboom Loaders
 Features 5-76
 Specifications 5-76
 Dimensions 5-77
 Lift and Range Diagrams 5-78
 Wheel Loaders
 Forestry Features 5-82
 Forestry Specifications 5-82
 Load Capacity Curves 5-83

SITE PREP

586C Site Prep Tractor
 Features 5-96
 Specifications 5-97
 Dimensions 5-98

WORKTOOLS

Grapples for Heel Boom Log Loaders
 Features 5-103
 Dimensions 5-104
 Logging Forks
 Features 5-105
 Specifications 5-105
 Couplers
 Features 5-110
 Buckets and Thumbs
 Features 5-110
 Woodchip Dozers and Scoops
 Features 5-111
 Specifications 5-111
 Rakes
 Features 5-112

TABLES

Log Volume Tables 5-113
 Weights of Commercially Important Woods 5-115
 Estimating Number of Trees 5-118
 Comparison of Log Rules 5-118
 Measurement Definitions 5-119
 Cubic Feet of Solid Wood per Cord 5-119
 Rule of Thumb Conversions 5-119

Sustainability:

- **Major structures and components** are built to be rebuilt, reducing waste and replacement costs.
- **ACERT™ Technology** reduces engine emissions at point of combustion with less moving parts for lower operating costs.

501 HD — Track Harvester Features:

- **Cat® C6.6 ACERT Technology** provides excellent fuel economy and the engines meet U.S. EPA Tier 3/ EU Stage IIIA/Japan 2006 (Tier 3) equivalent emission standards. Flex engines are available for HRC regions.
- **Optional 8.2 m (27 ft) telescopic boom** provides additional reach.
- **Unique front entry cab** allows for easy entry and exit.
- **Tilt cab** provides easy service.
- **Proven x-design carbody and large track system** provide strength and durability.
- **Large heavy-duty swing bearing and swing torque** enhance productivity.
- **Exceptional operator visibility.**
- **IQAN computer based control system** provides precise control of machine and attachment functions.

521B/522B —**Zero Tail Swing Track Harvester Features:**

- **Cat C9 ACERT Tier 3/Stage IIIA/Japan 2006 (Tier 3) equivalent high torque engine** provides excellent power, fuel economy, serviceability and durability.
- **The most robust tilt mechanism** in the industry, the tilting model (522B) has a patented 3-cylinder tilt mechanism with simultaneous tilting forward and side-to-side.
- **Proven rugged undercarriage** designed for the toughest harvesting conditions ranging from wet bottomlands to steep rocky slopes.
- **Hydraulically actuated clam-shell service door** provides full access and reduces maintenance down time.
- **Comfortable, purpose built forestry cab** with heavy duty guarding meets FOPS/ROPS/OPS or OR/OSHA requirements.
- **Flexaire fan (standard)** allows the cooling fan to purge debris from the radiator area minimizing cooling system maintenance.
- **Hydraulic system** is easily adaptable to both harvesting and directional felling heads.
- **IQAN display** allows the operator to continuously monitor the machine and get early warning for potential problems.
- **Ergonomically located pedals with side-by-side foot rests** provide maximum operator comfort when the machine is traveling.
- **Serviceability** has been improved with vertical mounted main hydraulic control valves and increased hood enclosure area. A larger standard fuel tank allows more run time between re-fueling stops.

541 Series 2/552 Series 2 — Full Tail Swing Track Harvester Features:

- **Cat C9 ACERT Tier 3/Stage IIIA/Japan 2006 (Tier 3) equivalent high torque engine** provides excellent power, fuel economy, serviceability and durability.
- **The most robust tilt mechanism** in the industry, the tilting model (552 Series 2) has a patented 3-cylinder tilt mechanism with simultaneous tilting forward and side-to-side.
- **Proven rugged undercarriage** designed for the toughest harvesting conditions ranging from wet bottomlands to steep rocky slopes.
- **Hydraulically actuated dual service door** provides engine/hydraulic access direct from the cab.
- **Walk through service access** minimizes service time and down time costs.
- **Comfortable, purpose built forestry cab** with heavy duty guarding meets FOPS/ROPS/OPS and OR/OSHA requirements.
- **Flexaire fan (standard)** allows the cooling fan to purge debris from the radiator area minimizing cooling system maintenance.
- **Hydraulic system** is easily adaptable to both harvesting and directional felling heads.
- **IQAN display** allows the operator to continuously monitor the machine and get early warning for potential problems.
- **Ergonomically located pedals with side-by-side foot rests** provide maximum operator comfort when the machine is traveling.

Track Harvesters

MODEL

501 HD

Gross Power (ISO 14396)	122 kW	163 hp
Operating Weight (without attachment)	18 000 kg	40,000 lb
Engine Model	C6.6 ACERT	
Emission Standards	Tier 3/Stage IIIA/Japan 2006 (Tier 3) equivalent	
Tractive Effort	19 686 kg	43,400 lb
Undercarriage:	D5	
Size		
Pitch	190.5 mm	7.5"
Maximum Reach (with head)	8200 mm	27'0"
Minimum Reach (with head)	3658 mm	12'0"
Fuel Capacity	378 L	100 U.S. gal
Hydraulic System	545 bar	5000 psi
Hydraulic Oil Flow	307 L/min	81 gpm
Hydraulic Oil Reservoir	230 L	60 U.S. gal
General Dimensions:		
Height (with standard pads)	3429 mm	11'3"
Width (with 610 mm/24" pads)	2845 mm	9'4"

ZTS (Zero Tail Swing)

MODEL

521B

522B

	521B		522B	
Gross Power (ISO 14396) @ 1800 RPM	226 kW	303 hp	226 kW	303 hp
Operating Weight (without head)	26 966 kg	59,450 lb	31 993 kg	70,532 lb
Engine Model	C9 ACERT		C9 ACERT	
Emission Standards	Tier 3/Stage IIIA/ Japan 2006 (Tier 3) equivalent		Tier 3/Stage IIIA/ Japan 2006 (Tier 3) equivalent	
Displacement	8.8 L	537 in ³	8.8 L	537 in ³
Tractive Effort — Standard	314 kN	70,500 lbf	336 kN	75,500 lbf
— Optional	—		378 kN	85,000 lbf
Undercarriage:	330 EX		330 EX	
Size				
Pitch	215.9 mm	8.5"	215.9 mm	8.5"
Track Gauge	2591 mm	102"	2591-2870 mm	102-113"
Track Length	4855 mm	191"	4855 mm	191"
Swing Torque	87.5 kN·m	64,500 lb·ft	87.5 kN·m	64,500 lb·ft
Swing Speed	6.8 RPM		6.8 RPM	
Maximum Reach (with head)	9.9 m	32'6"	9.9 m	32'6"
Bare Pin Lift @ Maximum Reach (without head)*	4000 kg @ 9.8 m	8800 lb @ 32'6"	4000 kg @ 9.8 m	8800 lb @ 32'6"
Fuel Capacity	856 L	226 U.S. gal	856 L	226 U.S. gal
Hydraulic System:	Electric		Electric	
Oil Fill Pump				
Variable Displacement Pumps:				
Travel and Tilt Functions (552 only)	416 L	110 gpm	416 L	110 gpm
Boom and Implement Functions	416 L	110 gpm	416 L	110 gpm
General Dimensions:				
Ground Clearance	889 mm	35"	889 mm	35"
Width (with 610 mm/24" Track Shoe)	3200 mm	126"	3200 mm	126"
Adjustable to	—		3480 mm	137"
Height (to top of cab with standard skylight)	3761 mm	148"	4011 mm	158"
Tail Swing (with Counterweight)	1929 mm	6'4"	1929 mm	6'4"

*Lift over front of tracks.

FTS (Full Tail Swing) MODEL

	541 Series 2		552 Series 2	
Gross Power (ISO 14396) @ 1800 RPM	226 kW	303 hp	226 kW	303 hp
Operating Weight (without head):				
Standard Harvester Linkage	31 135 kg	68,640 lb	36 124 kg	79,639 lb
Long Harvester Linkage	31 147 kg	68,667 lb	36 151 kg	79,700 lb
Engine Model	C9 ACERT		C9 ACERT	
Emission Standards	Tier 3/Stage IIIA/ Japan 2006 (Tier 3) equivalent		Tier 3/Stage IIIA/ Japan 2006 (Tier 3) equivalent	
Displacement	8.8 L	537 in³	8.8 L	537 in³
Tractive Effort	336 kN	75,500 lbf	463 kN	104,000 lbf
Undercarriage:				
Size	330 EX		345 EX	
Pitch	215.9 mm	8.5"	215.9 mm	8.5"
Track Gauge	2591-2870 mm	102-113"	2591-2870 mm	102-113"
Track Length	4893 mm	192.6"	4903 mm	193"
Swing Torque	97.6 kN-m	72,000 lb-ft	97.6 kN-m	72,000 lb-ft
Swing Speed	6.8 RPM		6.8 RPM	
Maximum Reach (long linkage with head)	10.7 m	35'0"	10.7 m	35'0"
Bare Pin Lift @ Maximum Reach (without head):*				
Standard Harvester Linkage	6400 kg @ 8.2 m	14,100 lb @ 27'0"	7700 kg @ 8.2 m	16,900 lb @ 27'0"
Long Harvester Linkage	4300 kg @ 10.7 m	9480 lb @ 35'0"	5700 kg @ 10.7 m	12,500 lb @ 35'0"
Fuel Capacity	1181 L	312 U.S. gal	1181 L	312 U.S. gal
Hydraulic System:				
Oil Fill Pump	Electric		Electric	
Variable Displacement Pumps:				
Travel and Implement Functions (x2)	416 L	110 gpm	416 L	110 gpm
General Dimensions:				
Ground Clearance	889 mm	35"	889 mm	35"
Width (with 710 mm/28" Track Shoe)	3327 mm	131"	3327 mm	131"
Adjustable to	3607 mm	142"	3607 mm	142"
Height (to top of cab with standard skylight)	3556 mm	140"	3962 mm	156"
Tail Swing	2743 mm	9'0"	2743 mm	9'0"

*Lift over front of tracks.

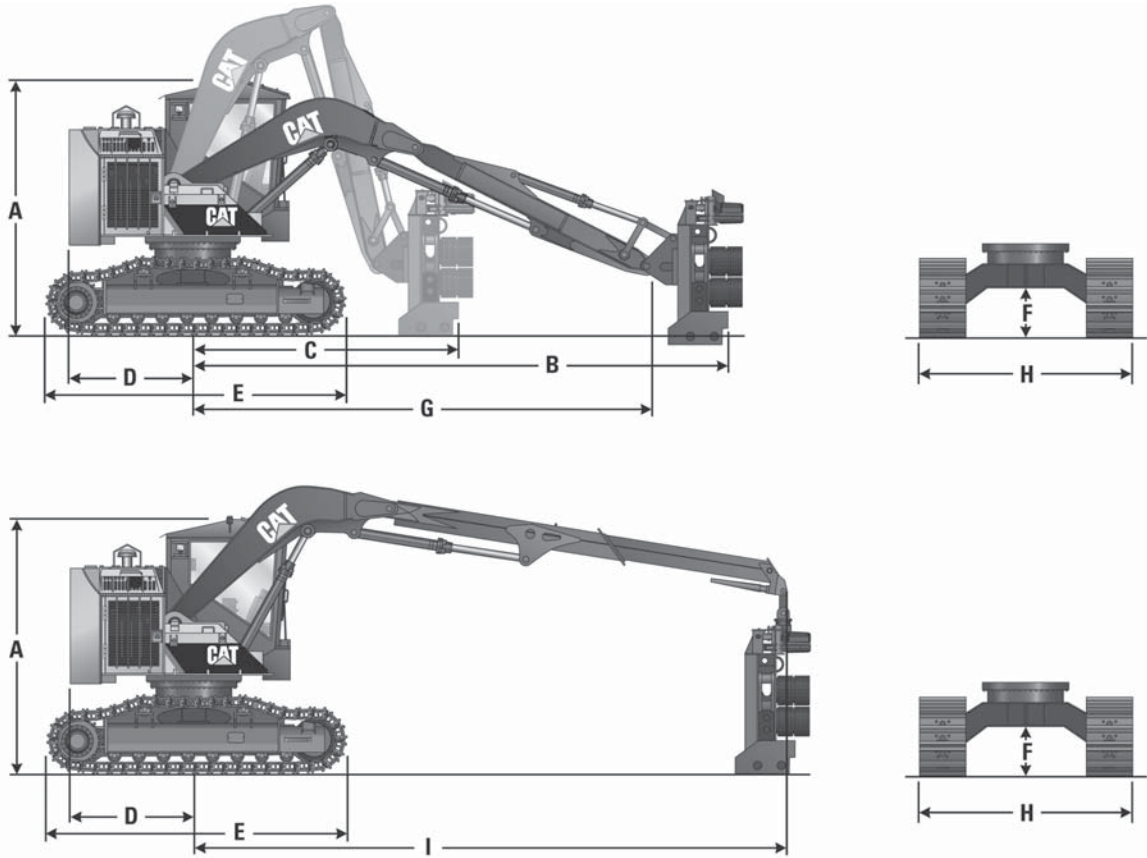

MODEL

501 HD

A Height with Standard Pads	3429 mm	11'3"
B Maximum Reach with Prentice PF-48 Processor	7087 mm	23'3"
C Minimum Reach with Prentice PF-48 Processor	3658 mm	12'0"
D Swing Center to Rear of Counterweight	1645 mm	64.75"
E Undercarriage Length	3962 mm	13'0"
F Ground Clearance	660 mm	26"
G Reach to Stick Boom Pin with Standard Boom	6045 mm	19'10"
H Width – with 610 mm (24 in) Pads	2845 mm	9'4"
I Reach to Stick Boom Pin with Telescopic Boom Extended	7930 mm	26'0"

These illustrations and values are ESTIMATED for TRUCK SHIPMENT ONLY FROM THE FACTORY. These are subject to change based on attachments, configurations, add-ons, etc.

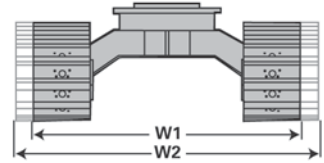

521B (Non-Tilter) ZTS Track Harvesters

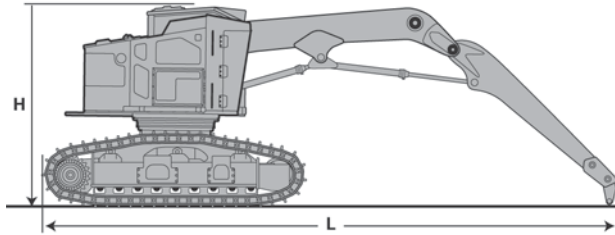

522B (Tilter) ZTS Track Harvesters

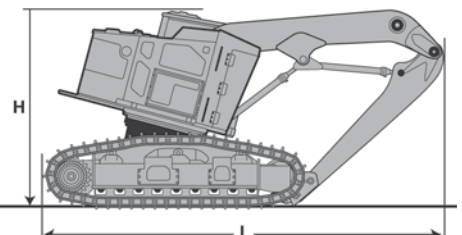

ZTS Track Harvesters Shipping Dimensions

MODEL	Length		Height*		Width 1+		Width 2++		Weight	
521B	12 151 mm	478"	3761 mm	148"	3200 mm	126"	—		26 966 kg	59,450 lb
522B**	8222 mm	324"	4011 mm	158"	3200 mm	126"	3480 mm	137"	31 993 kg	70,532 lb

Length, Height and Width 1 assume 610 mm (24") Single Grouser shoes.

*Height to the highest point on machine.

**Boom tucked.

+Width 1 is minimum width with 610 mm (24") Single Grouser shoes.

++Width 2 is maximum width when undercarriage is set wide.

These illustrations and values are ESTIMATED for TRUCK SHIPMENT ONLY FROM THE FACTORY. These are subject to change based on attachments, configurations, add-ons, etc.

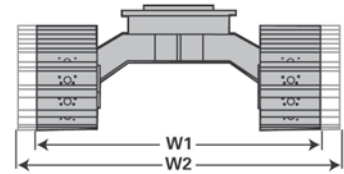

541 Series 2 (Non-Tilter) FTS Track Harvesters

552 Series 2 (Tilter) FTS Track Harvesters

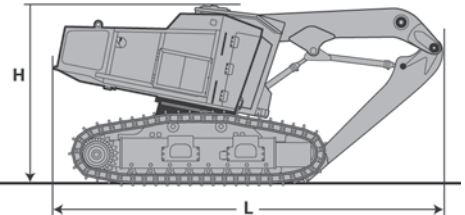
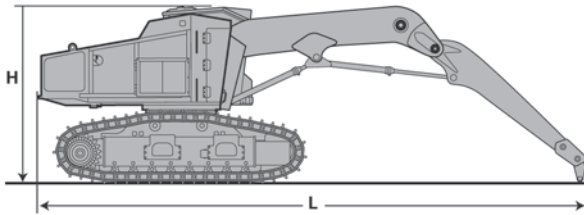

FTS Track Harvesters Shipping Dimensions

MODEL	Length		Height*		Width 1+		Width 2++		Weight	
541 Series 2										
Standard Harvester Linkage	11 074 mm	436"	3556 mm	140"	3327 mm	131"	3607 mm	142"	31 135 kg	68,640 lb
Long Harvester Linkage	13 614 mm	536"	3556 mm	140"	3327 mm	131"	3607 mm	142"	31 147 kg	68,667 lb
552 Series 2**										
Standard Harvester Linkage	11 024 mm	434"	3962 mm	156"	3327 mm	131"	3607 mm	142"	36 124 kg	79,639 lb
Long Harvester Linkage	7010 mm	276"	3962 mm	156"	3327 mm	131"	3607 mm	142"	36 151 kg	79,700 lb

Length, Height and Width assume 711 mm (28") Single Grouser shoes.

*Height to the highest point on machine.

**Boom tucked.

+Width 1 is minimum width with 711 mm (28") Single Grouser shoes.

++Width 2 is maximum width when undercarriage is set wide.

Lift Range Information —
501HD Fixed Head Boom Sweep

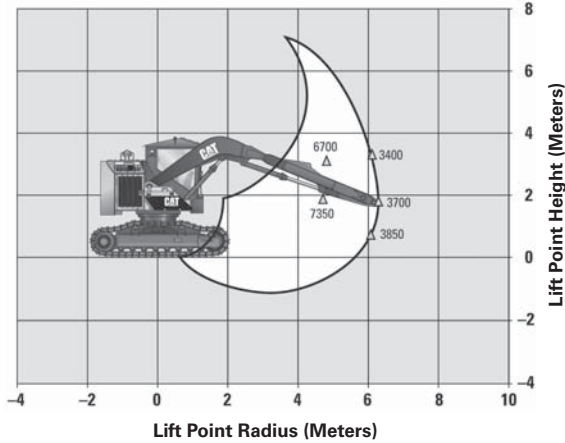

— SWEEP Δ Lift (kg)

Lift Range Information —
501HD Telescopic Boom Sweep

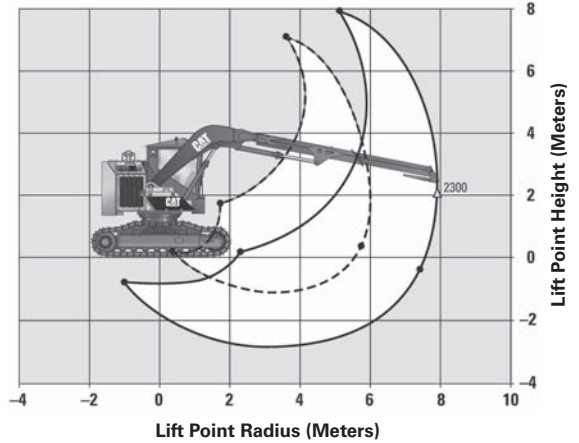

— ARM EXTENDED - - - - ARM RETRACTED Δ Lift (kg)

Lift Range Information —
501HD Fixed Head Boom Sweep

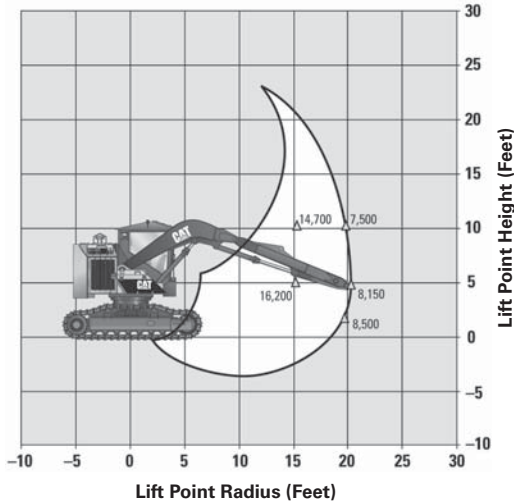

— SWEEP Δ Lift (lb)

Lift Range Information —
501HD Telescopic Boom Sweep

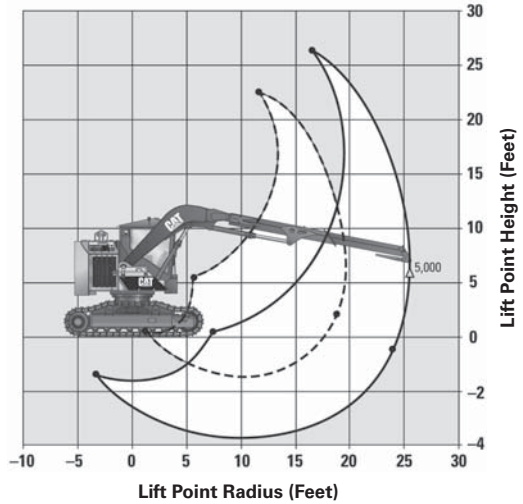

— ARM EXTENDED - - - - ARM RETRACTED Δ Lift (kg)

**Lift Range Information –
Harvester Linkage
521B/522B – ZTS**

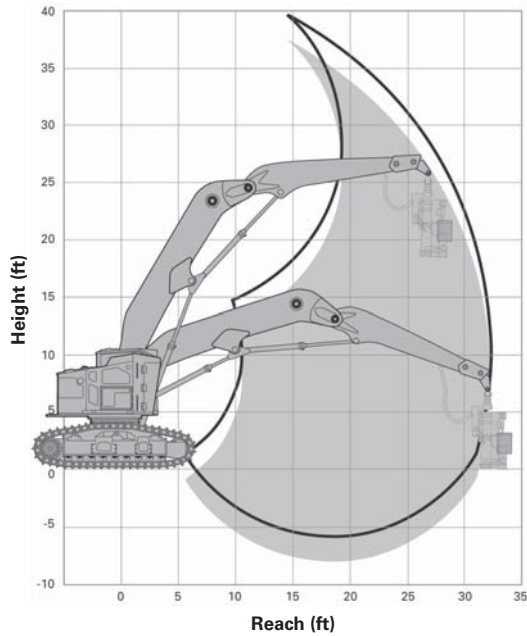

NOTE: ____ Line represents Tilter Model.

Lift Over Front of Tracks

MODEL	521B		522B	
Reach	Lift Capacity		Lift Capacity	
3.6 m (12'0")	10 500 kg	23,000 lb	10 500 kg	23,000 lb
6.1 m (20'0")	7700 kg	17,000 lb	7700 kg	17,000 lb
9.8 m (32'2")	4000 kg	8800 lb	4150 kg	9100 lb

Lift Over Side of Tracks

MODEL	521B		522B	
Reach	Lift Capacity		Lift Capacity	
3.6 m (12'0")	10 500 kg	23,000 lb	10 500 kg	23,000 lb
6.1 m (20'0")	7700 kg	17,000 lb	7700 kg	17,000 lb
9.8 m (32'2")	3630 kg	8000 lb	4150 kg	9100 lb

NOTE: Lift Capacity shown without attachment.
Additional reach and attachment weight will reduce lift capacity.

Lift Range Information – Standard Harvester Linkage 541 Series 2/552 Series 2 – FTS

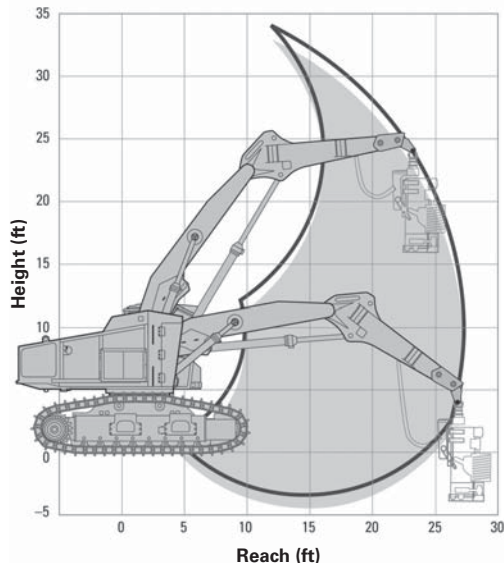

NOTE: ____ Line represents Tilter Model.

Lift Range Information – Long Harvester Linkage 541 Series 2/552 Series 2 – FTS

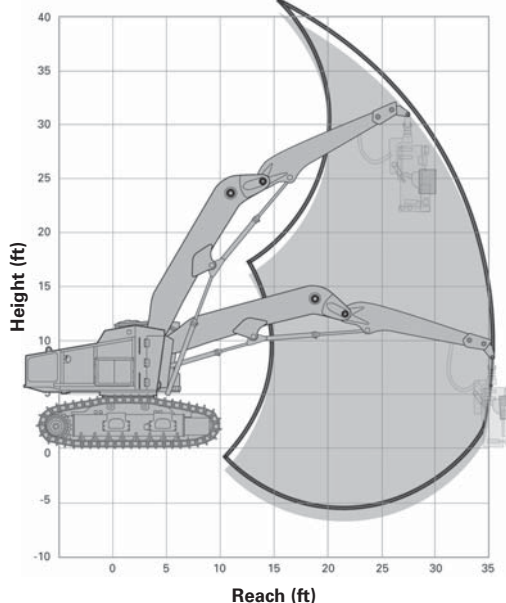

Lift Over Front of Tracks

MODEL	541 Series 2	552 Series 2
Reach	Lift Capacity	Lift Capacity
Linkage	Standard Harvester	Standard Harvester
3.0 m (10'0")	20 800 kg 45,900 lb	21 800 kg 48,000 lb
6.1 m (20'0")	10 400 kg 22,900 lb	10 900 kg 24,000 lb
8.2 m (27'0")	6400 kg 14,100 lb	7700 kg 16,900 lb
Reach	Lift Capacity	Lift Capacity
Linkage	Long Harvester	Long Harvester
4.5 m (15'0")	9100 kg 20,000 lb	9100 kg 20,000 lb
7.6 m (25'0")	7100 kg 15,700 lb	9400 kg 20,700 lb
10.7 m (35'0")	4300 kg 9500 lb	5700 kg 12,500 lb

Lift Over Side of Tracks

MODEL	541 Series 2	552 Series 2
Reach	Lift Capacity	Lift Capacity
Linkage	Standard Harvester	Standard Harvester
3.0 m (10'0")	20 800 kg 45,900 lb	21 800 kg 48,000 lb
6.1 m (20'0")	6600 kg 14,500 lb	9300 kg 20,500 lb
8.2 m (27'0")	4100 kg 9000 lb	6000 kg 13,200 lb
Reach	Lift Capacity	Lift Capacity
Linkage	Long Harvester	Long Harvester
4.5 m (15'0")	9100 kg 20,000 lb	9100 kg 20,000 lb
7.6 m (25'0")	4500 kg 9900 lb	6500 kg 14,300 lb
10.7 m (35'0")	2700 kg 5900 lb	4000 kg 8800 lb

NOTE: Lift Capacity shown without attachment.
Additional reach and attachment weight will reduce lift capacity.

521B/522B —**Zero Tail Swing Track Feller Buncher Features:**

- **Cat C9 ACERT Tier 3/Stage IIIA/Japan 2006 (Tier 3) equivalent high torque engine** provides excellent power, fuel economy, serviceability and durability.
- **A robust tilt mechanism**, the tilting model (522B) has a patented 3-cylinder tilt mechanism with simultaneous tilting forward and side-to-side.
- **Proven rugged undercarriage** designed for the toughest harvesting conditions ranging from wet bottomlands to steep rocky slopes.
- **Hydraulically actuated clam-shell service door** provides full service and reduces maintenance down time.
- **Comfortable, purpose built forestry cab** with heavy duty guarding meets FOPS/ROPS/OPS and OR/OSHA requirements.
- **Flexaire fan (standard)** allows the cooling fan to purge debris from the radiator area minimizing cooling system maintenance.
- **Felling heads** utilize high pressure hydraulics and proven components to meet your application requirements.
- **IQAN display** allows the operator to continuously monitor the machine and get early warning for potential problems.
- **Ergonomically located pedals with side-by-side foot rests** provide maximum operator comfort when the machine is traveling.
- **Serviceability** has been improved with vertical mounted main hydraulic control valves and increased hood enclosure area. A larger standard fuel tank allows more run time between re-fueling stops.
- **Hydraulic performance** has been enhanced with new compensator spools, improving implement and travel multi-functioning, and better hydraulic flow sharing between functions.

541 Series 2/552 Series 2 —**Full Tail Swing Track Feller Buncher Features:**

- **Cat C9 ACERT Tier 3/Stage IIIA/Japan 2006 (Tier 3) equivalent high torque engine** provides excellent power, fuel economy, serviceability and durability.
- **The most robust tilt mechanism** in the industry, the tilting model (552 Series 2) have a patented 3-cylinder tilt mechanism with simultaneous tilting forward and side-to-side.
- **Proven rugged undercarriage** designed for the toughest harvesting conditions ranging from wet bottomlands to steep rocky slopes.
- **Hydraulically actuated dual service door** provides engine/hydraulic access direct from the cab.
- **Walk through service access** minimizes service time and down time costs.
- **Comfortable, purpose built forestry cab** with heavy duty guarding meets FOPS/ROPS/OPS and OR/OSHA requirements.
- **Optional hydraulic packages** are available for operation with an intermittent saw or a high speed disc saw.
- **Felling heads** utilize high pressure hydraulics and proven components to meet your application requirements.
- **IQAN display** allows the operator to continuously monitor the machine and get early warning for potential problems.
- **Ergonomically located pedals with side-by-side foot rests** provide maximum operator comfort when the machine is traveling.
- **Flexaire fan (standard)** allows the cooling fan to purge debris from the radiator area minimizing cooling system maintenance.
- **Hydraulic performance** has been enhanced with new compensator spools, improving implement and travel multi-functioning, and better hydraulic flow sharing between functions.

ZTS (Zero Tail Swing) MODEL

	521B		522B	
Gross Power (ISO 14396) @ 1800 RPM	226 kW	303 hp	226 kW	303 hp
Operating Weight (without head)	27 501 kg	60,629 lb	32 528 kg	71,711 lb
Engine Model	C9 ACERT		C9 ACERT	
Emission Standards	Tier 3/Stage IIIA/ Japan 2006 (Tier 3) equivalent		Tier 3/Stage IIIA/ Japan 2006 (Tier 3) equivalent	
Displacement	8.8 L	537 in³	8.8 L	537 in³
Tractive Effort:				
Standard	314 kN	70,500 lbf	336 kN	75,500 lbf
Optional	—		378 kN	85,000 lbf
Undercarriage:				
Size	330 EX		330 EX	
Pitch	215.9 mm	8.5"	215.9 mm	8.5"
Track Gauge	2591 mm	102"	2591-2870 mm	102-113"
Track Length	4855 mm	191.1"	4855 mm	191.1"
Swing Torque	87.5 kN·m	64,500 lb-ft	87.5 kN·m	64,500 lb-ft
Swing Speed	6.8 RPM		6.8 RPM	
Maximum Reach (with head)	8.1 m	26'6"	8.1 m	26'6"
Bare Pin Lift @ Maximum Reach (without head)*	6100 kg @ 6.2 m	13,500 lb @ 20'6"	6100 kg @ 6.2 m	13,500 lb @ 20'6"
Fuel Capacity	856 L	226 U.S. gal	856 L	226 U.S. gal
Hydraulic System:				
Oil Fill Pump	Electric		Electric	
Variable Displacement Pumps:				
Travel and Tilt Functions (552 Only)	416 L	110 gpm	416 L	110 gpm
Boom and Implement Functions	416 L	110 gpm	416 L	110 gpm
Saw Pump	114 L	30 gpm	114 L	30 gpm
General Dimensions:				
Ground Clearance	889 mm	35"	889 mm	35"
Width (with 610 mm/24" Track Shoe)	3200 mm	126"	3200 mm	126"
Adjustable to	—		3480 mm	137"
Height (to top of cab with standard skylight)	3556 mm	140"	3901 mm	154"
Tail Swing (with Counterweight)	1929 mm	6'4"	1929 mm	6'4"

*Lift over front of tracks.

FTS (Full Tail Swing)**MODEL****541 Series 2****552 Series 2**

	541 Series 2		552 Series 2	
Gross Power (ISO 14396) @ 1800 RPM	226 kW	303 hp	226 kW	303 hp
Operating Weight (without head):				
Standard Linkage	30 826 kg	67,960 lb	35 816 kg	78,960 lb
Long Felling Linkage	31 135 kg	68,640 lb	36 124 kg	79,639 lb
Engine Model	C9 ACERT		C9 ACERT	
Emission Standards	Tier 3/Stage IIIA/ Japan 2006 (Tier 3) equivalent		Tier 3/Stage IIIA/ Japan 2006 (Tier 3) equivalent	
Displacement	8.8 L	537 in³	8.8 L	537 in³
Tractive Effort	336 kN	75,500 lbf	463 kN	104,000 lbf
Undercarriage:				
Size	330 EX		345 EX	
Pitch	215.9 mm	8.5"	215.9 mm	8.5"
Track Gauge	2591-2870 mm	102-113"	2591-2870 mm	102-113"
Track Length	4893 mm	192.6"	4903 mm	193"
Swing Torque	97.6 kN·m	72,000 lb-ft	97.6 kN·m	72,000 lb-ft
Swing Speed	6.8 RPM		6.8 RPM	
Maximum Reach (with head)	8.6 m	28'2"	8.6 m	28'2"
Bare Pin Lift @ Maximum Reach (without head)*	9400 kg @ 6.6 m	20,700 lb @ 21'8"	9400 kg @ 6.6 m	20,700 lb @ 21'8"
Bare Pin Lift @ Maximum Reach (without head)**	6400 kg @ 8.2 m	14,100 lb @ 27'0"	7700 kg @ 8.2 m	16,900 lb @ 27'0"
Fuel Capacity	1181 L	312 U.S. gal	1181 L	312 U.S. gal
Hydraulic System:				
Oil Fill Pump	Electric		Electric	
Variable Displacement Pumps:				
Travel and Implement Functions (x2)	416 L	110 gpm	416 L	110 gpm
Saw Pump	114 L	30 gpm	114 L	30 gpm
General Dimensions:				
Ground Clearance	889 mm	35"	889 mm	35"
Width (with 711 mm/28" Track Shoe)	3327 mm	131"	3327 mm	131"
Adjustable to	3607 mm	142"	3607 mm	142"
Height (to top of cab with standard skylight)	3556 mm	140"	3962 mm	156"
Tail Swing	2743 mm	9'0"	2743 mm	9'0"

*Standard linkage – Lift over front of tracks.

**Long felling linkage – Lift over front of tracks.

These illustrations and values are ESTIMATED for TRUCK SHIPMENT ONLY FROM THE FACTORY. These are subject to change based on attachments, configurations, add-ons, etc.

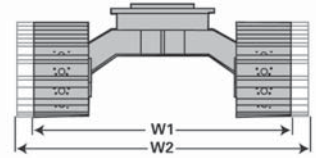

521B/522B ZTS Track Feller Bunchers

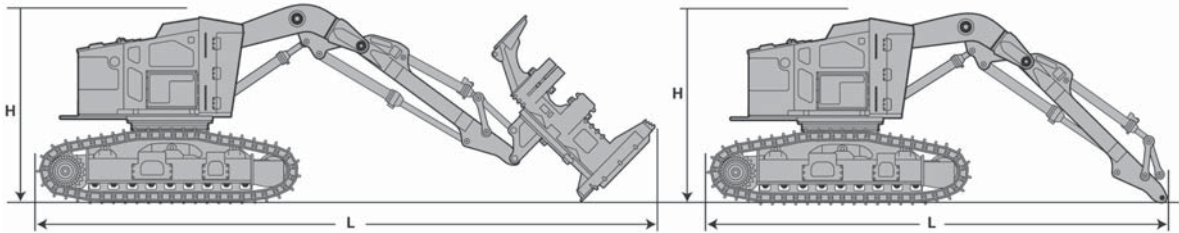

ZTS Track Feller Bunchers Shipping Dimensions

MODEL	Length		Height**		Width 1+		Width 2++		Weight	
521B	8352 mm	329"	3550 mm	140"	3200 mm	126"	—		27 501 kg	60,629 lb
521B*	10 708 mm	422"	3587 mm	141"	3200 mm	126"	—		30 701 kg	67,684 lb
522B	7700 mm	303"	3901 mm	154"	3200 mm	126"	3480 mm	137"	32 528 kg	71,711 lb
522B*	10 543 mm	415"	3901 mm	154"	3200 mm	126"	3480 mm	137"	35 728 kg	78,767 lb

Length, Height and Width assume 610 mm (24") Single Grouser shoes.

*With HF201B Partial Tilt Felling Head, tilted back and lifted (assumes an estimated additional head weight of 3200 kg (7054 lb)).

**Height is to the highest point on machine.

+Width 1 is minimum width with 610 mm (24") Single Grouser shoes.

++Width 2 is maximum width when undercarriage is set wide.

These illustrations and values are ESTIMATED for TRUCK SHIPMENT ONLY FROM THE FACTORY.
These are subject to change based on attachments, configurations, add-ons, etc.

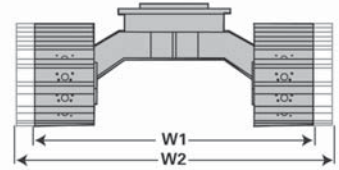

541 Series 2 (Non-Tilter) FTS Track Feller Bunchers Standard Linkage

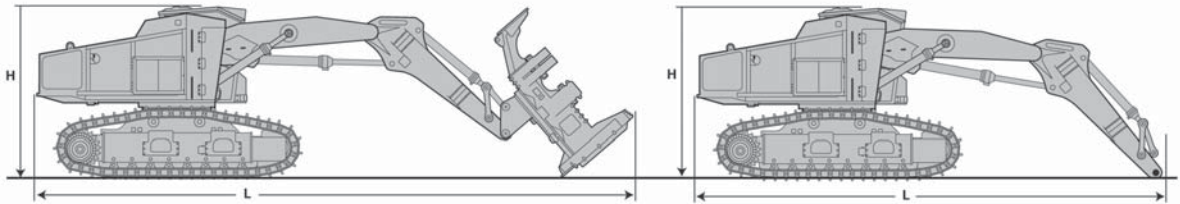

552 Series 2 (Tilter) FTS Track Feller Bunchers Standard Linkage

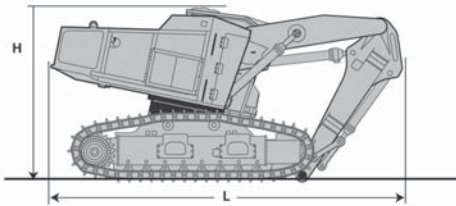

FTS Track Feller Bunchers Shipping Dimensions

MODEL	Length		Height**		Width 1+		Width 2++		Weight	
541 Series 2	9423 mm	371"	3556 mm	140"	3327 mm	131"	3607 mm	142"	30 826 kg	67,960 lb
541 Series 2*	11 709 mm	461"	3556 mm	140"	3327 mm	131"	3607 mm	142"	34 609 kg	76,300 lb
552 Series 2	9423 mm	371"	3962 mm	156"	3327 mm	131"	3607 mm	142"	35 816 kg	78,960 lb
552 Series 2*	11 709 mm	461"	3962 mm	156"	3327 mm	131"	3607 mm	142"	39 600 kg	87,300 lb

Length, Height and Width assume 711 mm (28") Single Grouser shoes.

*With HF221 Partial Tilt Felling Head, tilted back and lifted (assumes an estimated additional head weight of 3783 kg (8340 lb)).

**Height is to the highest point on machine.

+Width 1 is minimum width with 711 mm (28") Single Grouser shoes.

++Width 2 is maximum width when undercarriage is set wide.

These illustrations and values are ESTIMATED for TRUCK SHIPMENT ONLY FROM THE FACTORY. These are subject to change based on attachments, configurations, add-ons, etc.

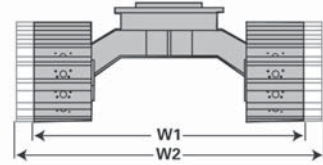

541 Series 2 (Non-Tilter) 552 Series 2 (Tilter) FTS Track Feller Bunchers Long Felling Linkage

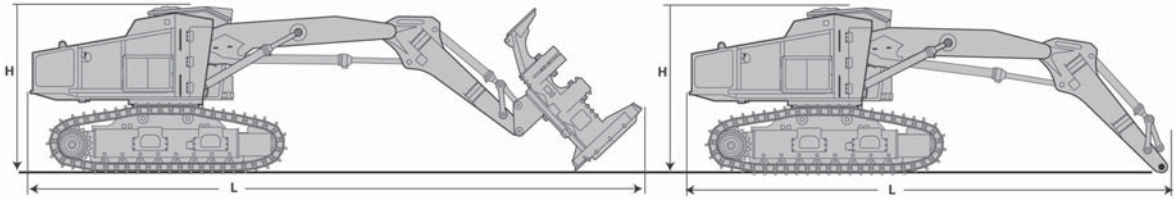

FTS Track Feller Bunchers Shipping Dimensions

MODEL	Length		Height**		Width 1+		Width 2++		Weight	
541 Series 2	11 074 mm	436"	3556 mm	140"	3327 mm	131"	3607 mm	142"	31 135 kg	68,640 lb
541 Series 2*	13 360 mm	526"	3556 mm	140"	3327 mm	131"	3607 mm	142"	34 335 kg	75,696 lb
552 Series 2	11 024 mm	434"	3962 mm	156"	3327 mm	131"	3607 mm	142"	36 124 kg	79,639 lb
552 Series 2*	13 310 mm	524"	3962 mm	156"	3327 mm	131"	3607 mm	142"	39 324 kg	86,694 lb

Length, Height and Width assume 711 mm (28") Single Grouser shoes.

*With HF201B Partial Tilt Felling Head, tilted back and lifted (assumes an estimated additional head weight of 3200 kg (7054 lb)).

**Height is to the highest point on machine.

+Width 1 is minimum width with 711 mm (28") Single Grouser shoes.

++Width 2 is maximum width when undercarriage is set wide.

Lift Range Information – Felling Linkage
521B/522B – ZTS

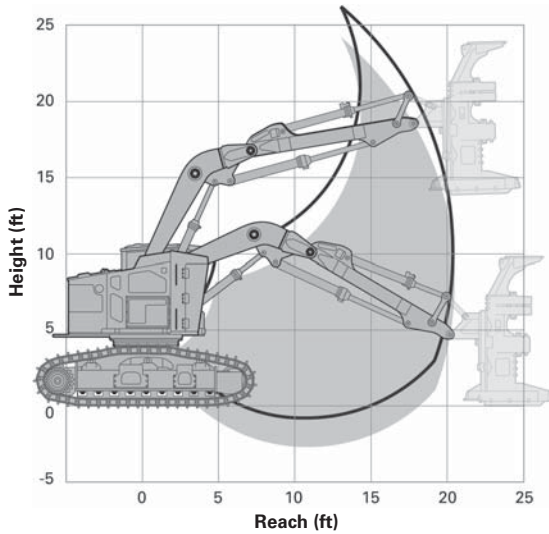

NOTE: ____ Line represents Tilter Model.

Lift Over Front of Tracks

MODEL	521B		522B	
Reach	Lift Capacity		Lift Capacity	
2.4 m (8'0")	15 450 kg	34,000 lb	16 180 kg	35,600 lb
4.5 m (15'0")	8410 kg	18,500 lb	8545 kg	18,800 lb
6.2 m (20'4")	6100 kg	13,500 lb	6100 kg	13,500 lb

Lift Over Side of Tracks

MODEL	521B		522B	
Reach	Lift Capacity		Lift Capacity	
2.4 m (8'0")	15 450 kg	34,000 lb	16 180 kg	35,600 lb
4.5 m (15'0")	8410 kg	18,500 lb	8545 kg	18,800 lb
6.2 m (20'4")	6100 kg	13,500 lb	6100 kg	13,500 lb

NOTE: Lift Capacity shown without attachment.
Additional reach and attachment weight will reduce lift capacity.

Lift Range Information — Standard Felling Linkage 541 Series 2/552 Series 2 — FTS

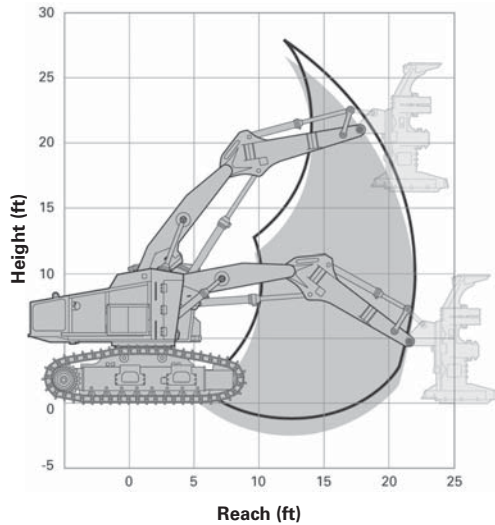

Lift Range Information — Long Felling Linkage 541 Series 2/552 Series 2 — FTS

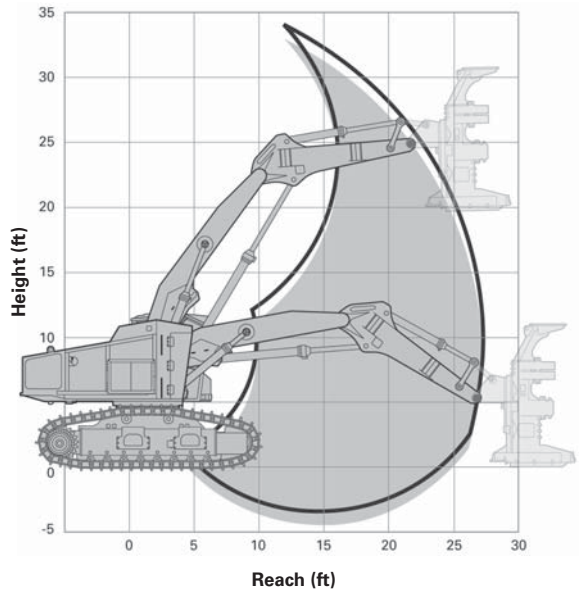

NOTE: ____ Line represents Tilter Model.

Lift Over Front of Tracks

MODEL	541 Series 2		552 Series 2	
Reach	Lift Capacity		Lift Capacity	
Linkage	Standard Felling		Standard Felling	
3.2 m (10'6")	21 600 kg	47,600 lb	22 200 kg	48,900 lb
4.5 m (15'0")	15 200 kg	33,500 lb	15 500 kg	34,200 lb
6.6 m (21'8")	9888 kg	21,800 lb	9888 kg	21,800 lb
Reach	Lift Capacity		Lift Capacity	
Linkage	Long Felling		Long Felling	
3.0 m (10'0")	20 800 kg	45,900 lb	21 800 kg	48,000 lb
6.1 m (20'0")	10 400 kg	22,900 lb	10 900 kg	24,000 lb
8.2 m (27'0")	6400 kg	14,100 lb	7700 kg	16,900 lb

Lift Over Side of Tracks

MODEL	541 Series 2		552 Series 2	
Reach	Lift Capacity		Lift Capacity	
Linkage	Standard Felling		Standard Felling	
3.2 m (10'6")	19 400 kg	42,800 lb	22 200 kg	48,900 lb
4.5 m (15'0")	10 600 kg	23,400 lb	14 900 kg	32,800 lb
6.6 m (21'8")	6100 kg	13,400 lb	8600 kg	19,000 lb
Reach	Lift Capacity		Lift Capacity	
Linkage	Long Felling		Long Felling	
3.0 m (10'0")	20 800 kg	45,900 lb	21 800 kg	48,000 lb
6.1 m (20'0")	6600 kg	14,500 lb	9300 kg	20,500 lb
8.2 m (27'0")	4100 kg	9000 lb	6000 kg	13,200 lb

NOTE: Lift Capacity shown without attachment.
Additional reach and attachment weight will reduce lift capacity.

553C/563C/573C Wheel Feller Buncher Features:

- The C Series has been designed for **maximum performance and increased model versatility** to meet multiple customer applications.
- Durable Cat C6.6 ACERT and C7.1 ACERT Engines with ACERT Technology meet the demanding power requirements of wheel feller buncher applications while meeting Tier 4 Interim/Stage IIIB/Japan 2011 (Tier 4 Interim) or Tier 3/Stage IIIA/Japan 2006 (Tier 3) equivalent emission standards.
- The **high capacity cooling system**, with a hydraulic on-demand reversing fan is designed to operate in high ambient air temperatures and high debris applications while improving component life.
- The **load sense hydraulic systems** provide power on demand and multi-functioning capabilities to all functions of the machine while minimizing fuel consumption.
- A **robust drivetrain** includes a proven hydrostatic drive system and robust Cat axles capable of operating dual tire or wide tire configurations increasing versatility and durability.
- **Heavy duty structures** utilize stream line box section design features, field proven dual taper roller bearing hitch design, integrated steering cylinder mounts, parent plate steering cylinder mounts and oversized chrome plated pins to provide increased life.
- The **transverse mounted engine** provides superior machine stability while providing ground level, single side engine service, ground level fuel fill, hinged service panels, and pressurized engine/hydraulic and Cat emissions module compartments minimizing potential debris accumulation.
- **Serviceability** has been improved by the transverse mounted engine and other standard features like an electric hydraulic oil fill pump, tilting cab, strategic bulkheads and routings to improve hose and wire harness life and serviceability, and machine fault codes displayed as a text message on the machine monitor to minimize downtime for daily checks, preventative maintenance, and emergency service.
- The **refined operator's station** is positioned evenly between the axles to provide excellent ride quality along with the standard air suspension seat, high capacity HVAC system, and ergonomic controls to reduce operator fatigue.
- **PowerDirect Plus** is a new system that optimizes the machine's performance by monitoring operator and attachment demand and delivering power where and when it is needed.

MODEL	553C		563C		573C	
Gross power (ISO 14396)	130 kW	174 hp	152 kW	203 hp	180 kW	241 hp
Engine Model	C6.6 ACERT		C7.1 ACERT		C7.1 ACERT	
Engine Speed	2200 RPM		1800 RPM		1800 RPM	
Travel Speed (Low Range with 28L x 26 tires)	0-7.2 km/h	0-4.5 mph	0-7.2 km/h	0-4.5 mph	0-7.2 km/h	0-4.5 mph
Travel Speed (High Range with 28L x 26 tires)	0-19.8 km/h	0-12.3 mph	0-19.8 km/h	0-12.3 mph	0-19.8 km/h	0-12.3 mph
Hydrostatic Pump (Variable displacement piston pump)	242 L/min @ 37 370 kPa	64 gpm @ 5420 psi	242 L/min @ 37 370 kPa	64 gpm @ 5420 psi	242 L/min @ 37 370 kPa	64 gpm @ 5420 psi
Primary Hydraulic Pump (Variable displacement piston pump)	155 L/min @ 27 579 kPa	41 gpm @ 4000 psi	155 L/min @ 27 579 kPa	41 gpm @ 4000 psi	155 L/min @ 27 579 kPa	41 gpm @ 4000 psi
Attachment Pump (Variable displacement piston pump)	155 L/min @ 27 579 kPa	41 gpm @ 4000 psi	155 L/min @ 27 579 kPa	41 gpm @ 4000 psi	155 L/min @ 27 579 kPa	41 gpm @ 4000 psi
Fuel Capacity	318 L	84 U.S. gal	318 L	84 U.S. gal	322 L	85 U.S. gal

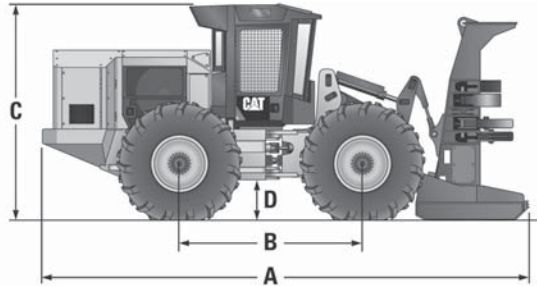
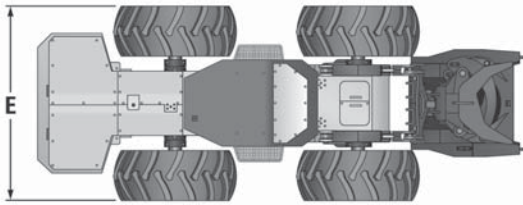

MODEL	553C		563C		573C	
A Overall Length						
Length (with SH-56B High Capacity Saw)	7375 mm	291"	7375 mm	291"	7502 mm	296"
Length (with SC-57 Felling Saw)	7432 mm	293"	7432 mm	293"	7559 mm	298"
B Wheelbase	2794 mm	110"	2794 mm	110"	2921 mm	115"
C Overall Height						
24.5L x 32	3306 mm	130.2"	3306 mm	130.2"	3306 mm	130.2"
28L x 26 NOAW	3223 mm	126.9"	3223 mm	126.9"	3223 mm	126.9"
28L x 26	3223 mm	126.9"	3223 mm	126.9"	3223 mm	126.9"
30.5L x 32 NOAW	3324 mm	130.9"	3324 mm	130.9"	3324 mm	130.9"
30.5L x 32	3324 mm	130.9"	3324 mm	130.9"	3324 mm	130.9"
30.5L x 32 2x Ring	3324 mm	130.9"	3324 mm	130.9"	3324 mm	130.9"
67 x 34	3251 mm	128.0"	3251 mm	128.0"	3251 mm	128.0"
D Ground Clearance						
24.5L x 32	610.2 mm	24.0"	610.2 mm	24.0"	610.2 mm	24.0"
28L x 26 NOAW	527.2 mm	20.8"	527.2 mm	20.8"	527.2 mm	20.8"
28L x 26	527.2 mm	20.8"	527.2 mm	20.8"	527.2 mm	20.8"
30.5L x 32 NOAW	628.2 mm	24.7"	628.2 mm	24.7"	628.2 mm	24.7"
30.5L x 32	628.2 mm	24.7"	628.2 mm	24.7"	628.2 mm	24.7"
30.5L x 32 2x Ring	628.2 mm	24.7"	628.2 mm	24.7"	628.2 mm	24.7"
67 x 34	555.2 mm	21.9"	555.2 mm	21.9"	555.2 mm	21.9"
E Overall Width						
24.5L x 32	2801 mm	110.3"	2801 mm	110.3"	2801 mm	110.3"
28L x 26 NOAW	2793 mm	110.0"	2793 mm	110.0"	2793 mm	110.0"
28L x 26	2920 mm	115.0"	2920 mm	115.0"	2920 mm	115.0"
30.5L x 32 NOAW	2980 mm	117.3"	2980 mm	117.3"	2980 mm	117.3"
30.5L x 32	3140 mm	123.6"	3140 mm	123.6"	3140 mm	123.6"
30.5L x 32 2x Ring	2966 mm	116.8"	2966 mm	116.8"	2966 mm	116.8"
67 x 34	3222 mm	126.9"	3222 mm	126.9"	3222 mm	126.9"

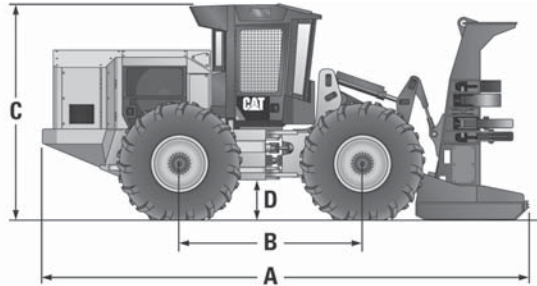
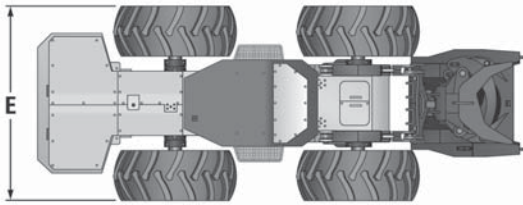

MODEL	553C		563C		573C	
F Articulation Angle						
24.5L x 32		40°		40°		45°
28L x 26 NOAW		45°		45°		45°
28L x 26		45°		45°		45°
30.5L x 32 NOAW		37°		37°		40°
30.5L x 32		35°		35°		40°
30.5L x 32 2x Ring		37°		37°		40°
67 x 34		37°		37°		42°
G Turning Radius						
24.5L x 32	5323 mm	209.6"	5323 mm	209.6"	5043 mm	198.6"
28L x 26 NOAW	4845 mm	190.7"	4845 mm	190.7"	5022 mm	197.7"
28L x 26	4883 mm	192.2"	4883 mm	192.2"	5085 mm	200.2"
30.5L x 32 NOAW	5731 mm	225.6"	5731 mm	225.6"	5595 mm	220.3"
30.5L x 32	6062 mm	238.7"	6062 mm	238.7"	5683 mm	223.8"
30.5L x 32 2x Ring	5728 mm	225.5"	5728 mm	225.5"	5595 mm	220.3"
67 x 34	5858 mm	230.6"	5858 mm	230.6"	5528 mm	217.6"
H Weight, less Attachment						
24.5L x 32	13 843 kg	30,520 lb	14 070 kg	31,020 lb	14 424 kg	31,800 lb
28L x 26 NOAW	13 862 kg	30,560 lb	14 089 kg	31,060 lb	14 442 kg	31,840 lb
28L x 26	13 862 kg	30,560 lb	14 089 kg	31,060 lb	14 442 kg	31,840 lb
30.5L x 32 NOAW	14 642 kg	32,280 lb	14 869 kg	32,780 lb	15 223 kg	33,560 lb
30.5L x 32	14 642 kg	32,280 lb	14 869 kg	32,780 lb	15 223 kg	33,560 lb
30.5L x 32 2x Ring	14 823 kg	32,680 lb	15 050 kg	33,180 lb	15 404 kg	33,960 lb
67 x 34	14 642 kg	32,280 lb	14 869 kg	32,780 lb	15 223 kg	33,560 lb

Track Feller Buncher Heads (Available with Partial Lateral and Full Lateral Tilt)

MODEL	HF201B		HF221	
Accumulation Area	0.46 m ²	5.0 ft²	0.51 m ²	5.5 ft²
Maximum Cut	572 mm	22.5"	620 mm	24.4"
Width	1702 mm	67"	1800 mm	70.9"
Height (including skids)	2910 mm	114.5"	3022 mm	119"
Weight (PLT)	3200 kg	7054 lb	3783 kg	8340 lb
Weight (FLT)	3669 kg	8090 lb	4182 kg	9220 lb

Wheel Feller Buncher Heads

MODEL	SH-50		SH-56B		SS-56	
Accumulation Area	0.58 m ²	6.2 ft²	0.69 m ²	7.4 ft²	0.37 m ²	4.0 ft²
Maximum Single Cut	508 mm	20"	560 mm	22"	560 mm	22"
Directional Felling Capacity	N/A		N/A		762 mm	30"
Width	1664 mm	65.5"	1664 mm	65.5"	1727 mm	68.0"
Height	2642 mm	104"	2722 mm	107.2"	2413 mm	95"
Weight	2919 kg	6435 lb	3122 kg	6885 lb	2973 kg	6554 lb

MODEL	SC-57		
Accumulation Area	0.47 m ²		5.1 ft²
Maximum Single Cut	576 mm		22.7"
Directional Felling Capacity		N/A	
Width	1615 mm		63.6"
Height	3023 mm		119"
Weight	3220 kg		7100 lb

Features:**Structures:**

- Leveraging a chassis design that has accumulated more than 40,000 hours in demanding felling applications, the SATCO Directional Felling Heads have a strong reputation of being one of the most reliable and efficient directional felling heads on the market.

Hydraulics:

- The directional felling heads are 100% hydraulic and do not have any electronics on the head. SATCO's "HOSE THROUGH CENTER" connection to the carrier allows the hoses to travel through the center line of the attaching pins. This prevents the hoses from over bending and causing premature failure. It also protects the hoses from damage when falling trees in dense forests. In addition, the 360 degree continuous rotation rotator allows felling in any possible direction in relation to the carrier without being limited by a rotation stop and without the possibility to damage hoses from over rotation of the head.

Saw Systems:

- The saw units are supported by a large 30 cm (12 in) diameter slew bearing making them a very robust saw unit especially designed for falling large diameter trees. The saw tensioning adjuster is a heavy duty manual adjuster with $\frac{3}{4}$ " pitch chain. The heads also use a unique locking system for the saw sprocket to prevent broken drive shaft keys and damaged saw motor shafts.

Applications:

- The SAT420 is ideally matched with a Cat 320D FM harvester for efficient felling. The head is most effective when single felling trees between 305–508 mm (12–20 in). The shorter tilt frame and chassis and the smaller jaw opening provide quick motion to reset the felling head for the next cut compared to a SAT630.
- The SAT630 is ideally matched with a Cat 324D FM Harvester or Cat 522B leveling track harvester. The head provides the most benefit when single felling trees between 457–762 mm (18–30 in). However the SAT630 becomes more effective than the SAT420 when the majority of the trees being felled exceed 500 mm (20 in).

Owning & Operating Costs:

- Both directional felling heads provide low owning and operating costs when compared to traditional high speed disc felling heads. Not only do the directional felling heads require less horsepower, consume less fuel, the heads also provide less stress on carrier components such as pins, bushings, stick, and boom joints due to the floating motion of the head once the trees are felled.

Harvesting SATCO Directional Felling Heads

Specifications

MODEL	SAT420		SAT630	
Weight	1450 kg	3100 lb	2000 kg	4400 lb
Height to Link Pin	2114 mm	83"	2405 mm	95"
Maximum Jaw Open	965 mm	38"	1400 mm	55"
Minimum Jaw Close	100 mm	4"	120 mm	5"
Optimal Capacity	305-508 mm	12-20"	457-762 mm	18-30"
Saw System:				
Chain Tensioning		Manual		Manual
Chain Pitch		$\frac{3}{4}$ "		$\frac{3}{4}$ "
Saw Bearing Diameter	305 mm	12"	305 mm	12"
Maximum Cut Diameter	635 mm	25"	950 mm	38"

Directional Felling Heads	Forest Machines	Track Harvesters
SAT420	320D FM/324D FM/325D FM	521B/522B/501HD
SAT630	324D FM/325D FM	521B/522B/541 II/552 II

Application:

- This product is specifically designed for applications, which require removal of the bark. The HH44 DE cannot be used in a standard harvesting application.

Features:

Operator Station:

- Utilizes a mobile purpose built Microsoft Windows based computer system.
- Equipped with: color touch screen, heavy-duty processor housing, and mini space saving keyboard with integral track ball mouse.

Structures:

- Use of a chassis design that has proven effective in Eucalyptus, improvements were made to the structure to provide a durable frame for high cycle debarking applications.

Hydraulics:

- Heavy Duty double-hinged self-aligning covers allow for superior access and easier serviceability to the hydraulic valve.
- Mono-block valve decreases maintenance repairs and gives users easier control of all harvester head functions.

Measuring Devices:

- New length and diameter measuring systems increase reliability and reduces maintenance.
- Wide temperature range ensures accurate measurements.

Hoses:

- Cat XT™ ES (Enhanced Spiral) ToughGuard hoses are designed to have exceptional abrasion resistance and increased flexibility superior to standard hoses.

MODEL	HH44 DE	
Knives	2 fixed, 4 moveable	
Maximum Roller Opening	620 mm	24.4 in
Maximum Opening Upper Knives	603 mm	23.7 in
Maximum Opening Lower Knives	703 mm	27.7 in
Feed Force	0-22.6 kN @ 25 MPa	0-5076 lb @ 3625 psi
Feed Speed	0-5.7 m/sec	0-18.8 ft/sec
Weight	1542 kg	3400 lb
Main Saw:		
Bar Pitch/Type	10 mm	0.404 in
Bar Length	750 mm	29.5 in
Maximum Diameter Cut	650 mm	25.5 in
Maximum Chain Speed	40 m/sec	130 ft/sec
Hydraulic Pressure Requirement Maximum	25 MPa	3620 psi
Hydraulic Flow Requirement Minimum	184 L/min	48 gpm

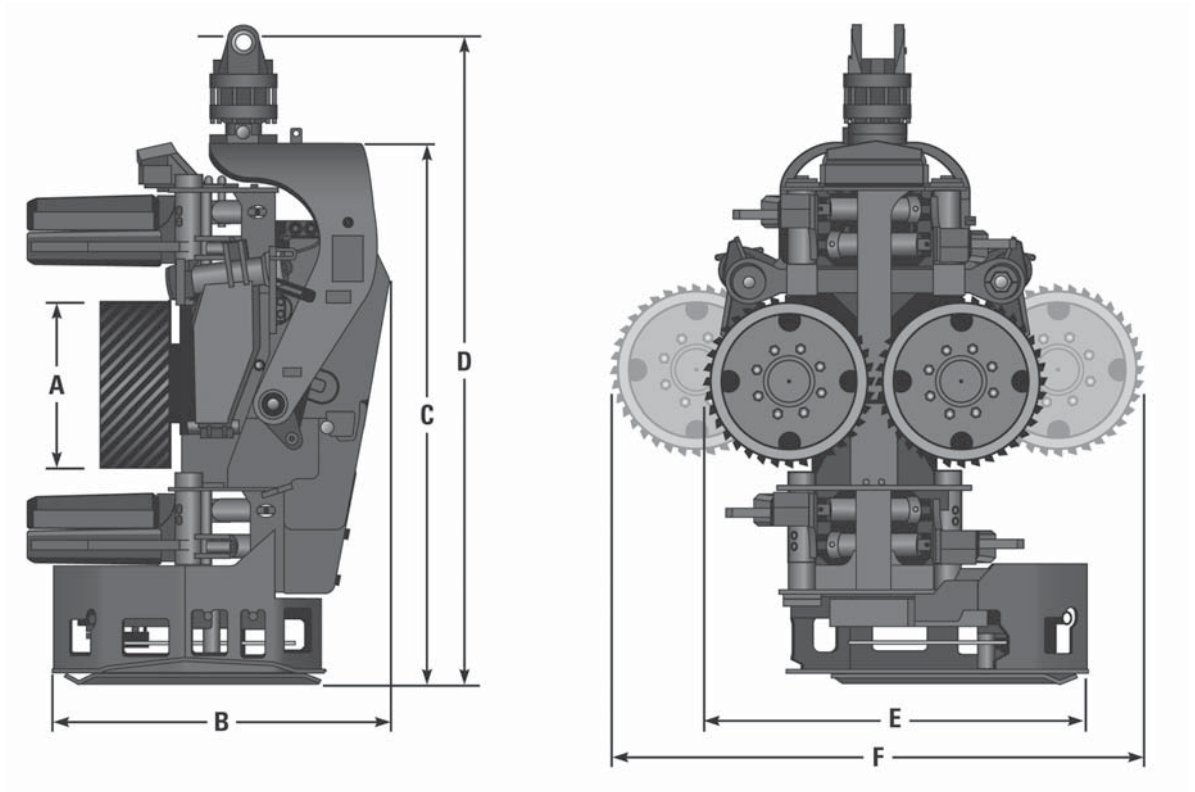

	A	B	C	D	E	F
mm	550	1080	1726	2057	1272	1772
in	21.7	42.5	68.0	81.0	50.0	69.8

Features:**Structures:**

- SATCO processing heads are designed with high tensile strength materials and utilize large pins for durability. The roller arm and knife pins on the heads are retained using SATCO's "DEAD-LOCK" pin retention system utilizing the pin for added strength in the chassis. The "DEAD-LOCK" pin retention system also prevents the pin from moving in all three axis improving bushing life and extending service intervals.

Hydraulics:

- A Rex Roth main valve is used on all SATCO processing heads and is rated at 420 bar (6100 psi) eliminating the need for carrier pressure reduction. SATCO's "HOSE THROUGH CENTER" connection to the carrier allows the hoses to travel through the center line of the attaching pins preventing the hoses from over bending and causing premature failure. It also protects the hoses from damage when falling trees in dense forests.

Saw Systems:

- SATCO processing heads utilize two different main saw systems depending on the head model. Most heads come equipped with SATCO's designed ¾" manual tension main saw system. The main saw units are supported by a large 30 cm (12 in) diameter slew bearing making them a very robust saw unit. The saw tensioning adjuster is a heavy duty manual adjuster with ¾" pitch chain. The heads also use a unique locking system for the saw sprocket to prevent broken drive shaft keys and damaged saw motor shafts.
- The SAT214, SAT318T SC, SAT322T SC, and SAT323T SC all utilize the Hultins SuperCut 100. The SC100 features 0.404" automatic chain tensioning and an integrated lubrication system.
- The SuperCut 100 is also used on most of the heads denoted by a "T" as a topping saw. This feature provides added versatility to the operator when processing. The one exception is the SAT325T which is equipped with the same SATCO designed ¾" saw system for both the main and topping saws.

Applications:

- The SAT214 is designed for pine thinning and select cutting smaller mixed stands. This head performs well in pine plantations and mixed natural stands.
- The SAT318/SAT318T/SAT318T SC are equipped with TMVW drive motors designed for lighter weight timber and perfect for feeding down to small diameters.
- The SAT322/SAT322T/SAT322T SC are equipped with HD hubs on the drive motors and work perfectly for larger heavy timber while still maintaining the ability to install on a 320D FM or a 521B/522B track harvester.
- The SAT323/SAT323T/SAT323T SC are equipped with MS11 drive motors providing increased torque. These heads paired with the 324D FM/325D FM machines have the capacity to consistently process large timber.
- The "SC" versions of the 18, 22, 23 inch heads works well for softwood applications and provides faster cutting cycles.
- Debarking is the specialty of the SAT422 DB and can handle a wide range of eucalyptus and acacia trees.
- The SAT223/SAT223T are best suited for processing short wood (6 m [20 ft]) or less. It is equipped with four knives and provides optimal delimiting of large limby wood.
- The largest offering is the SAT325/SAT325T and is designed for our largest FM the 568 FM. These heads work with the largest timber our machines can handle and stand up to the toughest applications.

Control System:

- SATCO heads have two control system options the Plus-1 and d5 Bucking Prio designed to suit many markets around the Globe.
- The Plus-1 system provides diameter based priority cut selection, simple length and diameter calibrations, metric or imperial display units as well as multiple languages. The Plus-1 measuring and control system is simple to use and does not require a PC in the cab. The system is ideal for customers who do not require sophisticated measuring systems.

- The d5 Bucking Prio control system is focused on simplicity, ease of operation, and provides priority bucking by prioritizing length and diameter calculations. The system also has the ability for production reporting and adding additional applications such as GPS* and Operational Monitoring*.

*Optional.

MODEL	SAT214	
Knives	1 Upper Fixed 4 Moveable/4 Cutting Edges	
Weight	1370 kg	3020 lb
Capacity	30-350 mm	1.25-14"
Close Minimum	30 mm	1.25"
Maximum Top Knives Open	600 mm	24"
Maximum Bottom Knives Open	600 mm	24"
Maximum Rollers Open	600 mm	24"
Maximum Feed Force:		
2 × TMVW 500 cc	18 kN	4046 lbf
2 × TMVW 630 cc	21 kN	4721 lbf
Maximum Feed Speed:		
2 × TMVW 500 cc	6 m/sec	19.7 ft/sec
2 × TMVW 630 cc	4.8 m/sec	15.7 ft/sec
Main Saw:		
Bar Pitch/Type	0.404" 18HX	
Bar Length	750 mm	29.5"
Maximum Diameter Cut	640 mm	25"
Chain/Bar Oil Capacity	17 L	4.5 U.S. gal
Recommended Hydraulic Pressure	300 bar	4351 psi
Recommended Hydraulic Flow	160 L/min	42 gpm
Dimensions:		
Roller Diameter	390 mm	15"
Depth	1080 mm	42.5"
Height to Rotator Pin	1950 mm	77"
Width Rollers Closed	1140 mm	45"
Width Rollers Open	1380 mm	54.5"

MODEL	SAT318		SAT318T		SAT318T SC	
Knives — Single and Single	1 Upper Floating 2 Moveable/ 2 Cutting Edges		1 Upper Floating 2 Moveable/ 2 Cutting Edges		1 Upper Floating 2 Moveable/ 2 Cutting Edges	
Weight	2486 kg	5481 lb	—	—	—	—
Weight with Topping Saw	—	—	2752 kg	6067 lb	2782 kg	6133 lb
TMVW Motors:						
Capacity	50-457 mm	2-18"	50-457 mm	2-18"	50-457 mm	2-18"
Close Minimum	50 mm	2"	50 mm	2"	50 mm	2"
Maximum Knives Open	690 mm	27"	690 mm	27"	690 mm	27"
Maximum Rollers Open	800 mm	31.5"	800 mm	31.5"	800 mm	31.5"
Maximum Feed Force:						
4 × 630 cc Motors	40 kN	9000 lbf	40 kN	9000 lbf	40 kN	9000 lbf
Maximum Feed Speed:						
4 × 630 cc Motors	4.8 m/sec	16 ft/sec	4.8 m/sec	16 ft/sec	4.8 m/sec	16 ft/sec
Main Saw:						
Bar Pitch/Type	¾"/11BC		¾"/11BC		0.404"/18HX	
Bar Length	914 mm	36"	914 mm	36"	902 mm	35"
Maximum Diameter Cut	730 mm	29"	730 mm	29"	730 mm	29"
Topping Saw Option:						
Bar Pitch/Type	—	—	0.404"/18HX		0.404"/18HX	
Bar Length	—	—	672 mm	26"	672 mm	26"
Maximum Diameter Cut	—	—	460 mm	18"	460 mm	18"
Chain/Bar Oil Capacity	17 L	4.5 U.S. gal	15 L	4.0 U.S. gal	15 L	4.0 U.S. gal
Recommended Hydraulic Pressure	300 bar	4351 psi	300 bar	4351 psi	300 bar	4351 psi
Recommended Hydraulic Flow	300 L/min	79 gpm	300 L/min	79 gpm	300 L/min	79 gpm
Dimensions:						
Roller Diameter — Thumbnail	390 mm	15"	390 mm	15"	390 mm	15"
Depth	1370 mm	54"	1370 mm	54"	1450 mm	54"
Height to Rotator Pin	1950 mm	77"	2210 mm	87"	2140 mm	84"
Width Rollers Closed	1720 mm	68"	1720 mm	68"	1680 mm	66"
Width Rollers Open	1910 mm	75"	1900 mm	75"	1900 mm	75"

MODEL	SAT322		SAT322T		SAT322T SC	
Knives — Single and Single	1 Upper Floating 2 Moveable/ 2 Cutting Edges		1 Upper Floating 2 Moveable/ 2 Cutting Edges		1 Upper Floating 2 Moveable/ 2 Cutting Edges	
Weight	2486 kg	5481 lb	—	—	—	—
Weight with Topping Saw	—	—	2752 kg	6067 lb	2782 kg	6133 lb
HD Hubs — OMV Drive Motors:						
Capacity	75-560 mm	3-22"	75-560 mm	3-22"	75-560 mm	3-22"
Close Minimum	75 mm	3"	75 mm	3"	75 mm	3"
Maximum Knives Open	690 mm	27"	690 mm	27"	690 mm	27"
Maximum Rollers Open	800 mm	31.5"	800 mm	31.5"	800 mm	31.5"
Maximum Feed Force:						
Debarking Configuration Only	30 kN	6745 lbf	—	—	—	—
4 × 630 cc Motors	40 kN	9000 lbf	40 kN	9000 lbf	40 kN	9000 lbf
Maximum Feed Speed:						
Debarking Configuration Only	5.8 m/sec	19 ft/sec	—	—	—	—
4 × 630 cc Motors	4.8 m/sec	16 ft/sec	4.8 m/sec	16 ft/sec	4.8 m/sec	16 ft/sec
Main Saw:						
Bar Pitch/Type	¾"/11BC		¾"/11BC		0.404"/18HX	
Bar Length	914 mm	36"	914 mm	36"	902 mm	35"
Maximum Diameter Cut	730 mm	29"	730 mm	29"	730 mm	29"
Topping Saw Option:						
Bar Pitch/Type	—	—	0.404"/18HX		0.404"/18HX	
Bar Length	—	—	672 mm	26"	672 mm	26"
Maximum Diameter Cut	—	—	460 mm	18"	460 mm	18"
Chain/Bar Oil Capacity	17 L	4.5 U.S. gal	15 L	4.0 U.S. gal	15 L	4.0 U.S. gal
Recommended Hydraulic Pressure	300 bar	4351 psi	300 bar	4351 psi	300 bar	4351 psi
Recommended Hydraulic Flow	300 L/min	79 gpm	300 L/min	79 gpm	300 L/min	79 gpm
Dimensions:						
Roller Diameter – Thumbnail	390 mm	15"	390 mm	15"	390 mm	15"
Roller Diameter – Debarking	480 mm	19"	480 mm	19"	480 mm	19"
Depth	1370 mm	54"	1370 mm	54"	1450 mm	54"
Height to Rotator Pin	1950 mm	77"	2210 mm	87"	2140 mm	84"
Width Rollers Closed	1720 mm	68"	1720 mm	68"	1680 mm	66"
Width Rollers Open	1900 mm	75"	1900 mm	75"	1900 mm	75"

MODEL**SAT422 DB**

MODEL	SAT422 DB	
Knives	1 Upper Fixed 2 Moveable/2 Cutting Edges	
Weight	2808 kg	6191 lb
Capacity	50-560 mm	2-22"
Close Minimum	50 mm	2"
Maximum Knives Open	800 mm	32"
Maximum Rollers Open	740 mm	29"
Maximum Feed Force: 4 × Danfoss 500 cc	28 kN	6300 lbf
Maximum Feed Speed: 4 × Danfoss 500 cc	5.8 m/sec	19 ft/sec
Main Saw:		
Bar Pitch/Type	¾"/11BC	
Bar Length	915 mm	36"
Maximum Diameter Cut	630 mm	25"
Chain/Bar Oil Capacity	15 L	4 U.S. gal
Recommended Hydraulic Pressure	300 bar	4351 psi
Recommended Hydraulic Flow	300 L/min	79 gpm
Dimensions:		
Roller Diameter	380 mm	15"
Depth	1430 mm	56.5"
Height to Rotator Pin	2280 mm	90"
Width Rollers Closed	1600 mm	63"
Width Rollers Open	1760 mm	69"

MODEL	SAT323		SAT323T		SAT323T SC	
Knives – “TRI-KNIFE” System	1 Upper Floating 2 Moveable/ 3 Cutting Edges		1 Upper Floating 2 Moveable/ 3 Cutting Edges		1 Upper Floating 2 Moveable/ 3 Cutting Edges	
Weight	2530 kg	5578 lb	—	—	—	—
Weight with Topping Saw	—	—	2790 kg	6151 lb	2810 kg	6203 lb
MS11 Motors:						
Capacity	50-590 mm	2-23"	50-590 mm	2-23"	50-590 mm	2-23"
Close Minimum	50 mm	2"	50 mm	2"	50 mm	2"
Maximum Knives Open	690 mm	27"	690 mm	27"	690 mm	27"
Maximum Rollers Open	800 mm	31.5"	800 mm	31.5"	800 mm	31.5"
Maximum Feed Force:						
2 × 630 cc, 2 × 837 cc Motors	42 kN	9445 lbf	42 kN	9445 lbf	42 kN	9445 lbf
Maximum Feed Speed:						
2 × 630 cc, 2 × 837 cc MS 11 Motors	5.5 m/sec	18 ft/sec	5.5 m/sec	18 ft/sec	5.5 m/sec	18 ft/sec
Main Saw:						
Bar Pitch/Type	¾"/11BC		¾"/11BC		0.404in/18HX	
Bar Length	914 mm	36"	914 mm	36"	902 mm	35"
Maximum Diameter Cut	730 mm	29"	730 mm	29"	730 mm	29"
Topping Saw Option:						
Bar Pitch/Type	—	—	0.404"/18HX		0.404"/18HX	
Bar Length	—	—	672 mm	26"	672 mm	26"
Maximum Diameter Cut	—	—	460 mm	18"	460 mm	18"
Chain/Bar Oil Capacity	17 L	4.5 U.S. gal	15 L	4.0 U.S. gal	15 L	4.0 U.S. gal
Recommended Hydraulic Pressure	300 bar	4351 psi	300 bar	4351 psi	300 bar	4351 psi
Recommended Hydraulic Flow	300 L/min	79 gpm	300 L/min	79 gpm	300 L/min	79 gpm
Dimensions:						
Roller Diameter – Thumbnail	515 mm	20"	515 mm	20"	515 mm	20"
Depth	1370 mm	54"	1370 mm	54"	1450 mm	54"
Height to Rotator Pin	1950 mm	77"	2210 mm	87"	2140 mm	84"
Width Rollers Closed	1720 mm	68"	1720 mm	68"	1680 mm	66"
Width Rollers Open	1900 mm	75"	1900 mm	75"	1900 mm	75"

MODEL	SAT223		SAT223T	
Knives	1 Upper Floating 4 Moveable/4 Cutting Edges		1 Upper Floating 4 Moveable/4 Cutting Edges	
Weight	3340 kg	7363 lb	3600 kg	7937 lb
Weight with Topping Saw	—		3545 kg	7800 lb
Capacity	60-590 mm	2-23"	60-590 mm	2-23"
Close Minimum	60 mm	2.4"	60 mm	2.4"
Maximum Top Knives Open	850 mm	33.5"	850 mm	33.5"
Maximum Bottom Knives Open	750 mm	29.5"	750 mm	29.5"
Maximum Rollers Open	800 mm	31.5"	800 mm	31.5"
Maximum Feed Force: 2 × MS11 1048 cc	45 kN	10,125 lbf	45 kN	10,125 lbf
Maximum Feed Speed: 2 × MS11 1048 cc	4.8 m/sec	15.7 ft/sec	4.8 m/sec	15.7 ft/sec
Main Saw:				
Bar Pitch/Type	¾"/11BC		¾"/11BC	
Bar Length	914 mm	36"	914 mm	36"
Maximum Diameter Cut	750 mm	29.5"	750 mm	29.5"
Topping Saw Option:				
Bar Pitch/Type	—		0.404"/18HX	
Bar Length	—		750 mm	29.5"
Maximum Diameter Cut	—		400 mm	15.5"
Chain/Bar Oil Capacity	15 L	4 U.S. gal	15 L	4 U.S. gal
Recommended Hydraulic Pressure	350 bar	5076 psi	350 bar	5076 psi
Recommended Hydraulic Flow	380 L/min	100 gpm	380 L/min	100 gpm
Dimensions:				
Roller Diameter — Thumbnail	550 mm	21.5"	550 mm	21.5"
Depth	1390 mm	55"	1390 mm	55"
Height to Rotator Pin	2400 mm	95"	2400 mm	95"
Width Rollers Closed	1580 mm	62"	1580 mm	62"
Width Rollers Open	1890 mm	74.5"	1890 mm	74.5"

MODEL	SAT325		SAT325T	
Knives – Tri-Knife System	1 Upper Floating 2 Moveable/3 Cutting Edges		1 Upper Floating 2 Moveable/3 Cutting Edges	
Weight	3580 kg	7893 lb	4108 kg	9057 lb
Capacity	75-660 mm	3-26"	75-660 mm	3-26"
Close Minimum	75 mm	3"	75 mm	3"
Maximum Top Knives Open	1000 mm	40"	1000 mm	40"
Maximum Bottom Knives Open	N/A		N/A	
Maximum Rollers Open	1000 mm	40"	1000 mm	40"
Maximum Feed Force:				
2 × Poclairn 837 cc and 2 × Danfoss 500cc	48 kN	10,790 lbf	48 kN	10,790 lbf
2 × Poclairn 1048 cc and 2 × Danfoss 630cc	55 kN	12,365 lbf	55 kN	12,365 lbf
Maximum Feed Speed:				
2 × Poclairn 837 cc and 2 × Danfoss 500cc	5.1 m/sec	17 ft/sec	5.1 m/sec	17 ft/sec
2 × Poclairn 1048 cc and 2 × Danfoss 630cc	4.1 m/sec	13.5 ft/sec	4.1 m/sec	13.5 ft/sec
Main Saw:				
Bar Pitch/Type	¾"/11BC		¾"/11BC	
Bar Length	1092 mm	43"	1092 mm	43"
Maximum Diameter Cut	800 mm	31.5"	800 mm	31.5"
Topping Saw Option:				
Bar Pitch/Type	—		¾"/11BC	
Bar Length	—		1092 mm	43"
Maximum Diameter Cut	—		690 mm	27"
Chain/Bar Oil Capacity	17 L	4.5 U.S. gal	17 L	4.5 U.S. gal
Recommended Hydraulic Pressure	350 bar	5076 psi	350 bar	5076 psi
Recommended Hydraulic Flow	380 L/min	100 gpm	380 L/min	100 gpm
Dimensions:				
Roller Diameter – Pine and Alpine	445 mm	17.5"	445 mm	17.5"
Depth	1440 mm	57"	1440 mm	57"
Height to Rotator Pin	2580 mm	101"	2850 mm	112"
Width Rollers Closed	1880 mm	74"	1880 mm	74"
Width Rollers Open	1970 mm	77.5"	1970 mm	77.5"

525D/535D/545D/555D Wheel Skidder Features:

- The Cat C7.1 ACERT engine is designed to deliver more power than ever before, while still achieving the highest levels of total fluid efficiency, reliability and durability.
- The **high capacity cooling system** and on-demand hydraulically driven reversing fan keep the machine running at the proper operating temperature, optimizing performance, durability and fuel efficiency. The system, designed to meet the cooling requirements of the 555D, is common to all models, boosting fuel efficiency and capacity in the smaller models.
- Power to the ground is an advantage of the Cat D Series **power train**. The axles are designed specifically for the skidder application and the gear ratios cause the power to be generated in the axles reducing torque in the transmission and drivelines extending their life. Both drawbar performance and durability are improved.
- The **high performance hydraulic system** provides more speed, increased multifunctioning capability and greater lift capacity. This efficient load sense system with variable displacement pump continually monitors hydraulic power requirements and provides power based on demand to save fuel.
- **Rock solid stability** through improved weight distribution and a longer wheelbase keep the skidder solid, even in turns. Robust frames provide a solid foundation for a machine designed to provide long life. Every structure was engineered for durability and verified through lab and field tests.
- Logging and retrieval **winch**es are available as options. Both are hydraulically driven, have the same pulling power and feature friction style clutches for increased durability and functionality.
- The **refined operator's station** is positioned evenly between the axles to provide excellent ride quality along with the high back air suspension seat, high capacity HVAC system, and ergonomic controls to reduce operator fatigue.
- **Serviceability** of the D Series is significantly improved with the tilting cab, redesigned grapple head and improved hose routings. The cross flow configuration and compartmentalization reduce debris collection around the engine, so less time is needed for cleaning.
- **Integrated technologies** like the machine troubleshooting feature which allows the operator to drill down and pinpoint the root cause of a problem, reducing the need for service calls and holding down costs. Product Link™ is also integrated to collect and deliver valuable information which is important with logging sites in remote areas.

MODEL	525D		535D	
Engine:	C7.1 ACERT		C7.1 ACERT	
Engine Model				
Gross Power	151 kW	203 hp	168 kW	225 hp
Displacement	7.0 L	428 in³	7.0 L	428 in³
Bore	105 mm	4.13"	105 mm	4.13"
Stroke	135 mm	5.31"	135 mm	5.31"
Number of Cylinders	6		6	
Maximum Torque @ 1400 rpm	922 N·m	680 lb-ft	1028 N·m	758 lb-ft
Derating Altitude	3000 m	9843 ft	3000 m	9843 ft
Electrical System	24V		24V	
Battery — Quantity	2		2	
Battery — Volts	12V		12V	
Battery — Capacity	950 CCA		950 CCA	
Power Train:	Countershaft Powershift		Countershaft Powershift	
Transmission	Water to Oil		Water to Oil	
Transmission Cooler Type				
Travel Speed — Fwd 1st	5.6 km/h	3.5 mph	5.6 km/h	3.5 mph
Travel Speed — Fwd 2nd	7.6 km/h	4.7 mph	7.6 km/h	4.7 mph
Travel Speed — Fwd 3rd	10.4 km/h	6.5 mph	10.4 km/h	6.5 mph
Travel Speed — Fwd 4th	14.1 km/h	8.8 mph	14.1 km/h	8.8 mph
Travel Speed — Fwd 5th	18.9 km/h	11.8 mph	18.9 km/h	11.8 mph
Travel Speed — Fwd 6th	20.0 km/h	12.4 mph	20.0 km/h	12.4 mph
Travel Speed — Rev 1st	5.6 km/h	3.5 mph	5.6 km/h	3.5 mph
Travel Speed — Rev 2nd	10.4 km/h	6.5 mph	10.4 km/h	6.5 mph
Travel Speed — Rev 3rd	18.9 km/h	11.8 mph	18.9 km/h	11.8 mph
Brakes:	Enclosed wet single disc		Enclosed wet single disc	
Service	Spring applied, hydraulically released		Spring applied, hydraulically released	
Transmission Cooler Type				
Hydraulic System:	Load sense, closed center		Load sense, closed center	
Type	Variable displacement piston pump		Variable displacement piston pump	
Pump Type				
Pump Output	220 L/min	58 gpm	220 L/min	58 gpm
Service Refill:				
Fuel Tank	315 L	83.2 U.S. gal	378 L	99.8 U.S. gal
DEF Tank*	19 L	5.0 U.S. gal	19 L	5.0 U.S. gal
Engine Oil	27 L	7.1 U.S. gal	27 L	7.1 U.S. gal
Cooling System	57 L	15.1 U.S. gal	57 L	15.1 U.S. gal
Transmission, Torque Converter	54 L	14.3 U.S. gal	54 L	14.3 U.S. gal
Parking Brake	425 mL	14.4 oz	425 mL	14.4 oz
Differential, Final Drive:				
Front	52 L	13.7 U.S. gal	52 L	13.7 U.S. gal
Rear	52 L	13.7 U.S. gal	52 L	13.7 U.S. gal
Hydraulic System:				
Tank	65 L	17.2 U.S. gal	65 L	17.2 U.S. gal
Total	123 L	32.5 U.S. gal	123 L	32.5 U.S. gal

*Tier 4 Final/Stage IV/Japan 2014 (Tier 4 Final) equipped machines only.

MODEL	545D		555D	
Engine:	C7.1 ACERT		C7.1 ACERT	
Engine Model	186 kW	250 hp	205 kW	275 hp
Gross Power	7.0 L	428 in³	7.0 L	428 in³
Displacement	105 mm	4.13"	105 mm	4.13"
Bore	135 mm	5.31"	135 mm	5.31"
Stroke		6		6
Number of Cylinders	1142 N·m	842 lb-ft	1257 N·m	927 lb-ft
Maximum Torque @ 1400 rpm	3000 m	9843 ft	3000 m	9843 ft
Derating Altitude		24V		24V
Electrical System		2		2
Battery — Quantity		12V		12V
Battery — Volts		950 CCA		950 CCA
Battery — Capacity	Countershaft Powershift		Countershaft Powershift	
Power Train:	Water to Oil		Water to Oil	
Transmission	5.6 km/h	3.5 mph	5.6 km/h	3.5 mph
Transmission Cooler Type	7.6 km/h	4.7 mph	7.6 km/h	4.7 mph
Travel Speed — Fwd 1st	10.4 km/h	6.5 mph	10.4 km/h	6.5 mph
Travel Speed — Fwd 2nd	14.1 km/h	8.8 mph	14.1 km/h	8.8 mph
Travel Speed — Fwd 3rd	18.9 km/h	11.8 mph	18.9 km/h	11.8 mph
Travel Speed — Fwd 4th	20.0 km/h	12.4 mph	20.0 km/h	12.4 mph
Travel Speed — Fwd 5th	5.6 km/h	3.5 mph	5.6 km/h	3.5 mph
Travel Speed — Fwd 6th	10.4 km/h	6.5 mph	10.4 km/h	6.5 mph
Travel Speed — Rev 1st	18.9 km/h	11.8 mph	18.9 km/h	11.8 mph
Travel Speed — Rev 2nd				
Travel Speed — Rev 3rd	Enclosed wet single disc		Enclosed wet single disc	
Brakes:	Spring applied, hydraulically released		Spring applied, hydraulically released	
Service	Load sense, closed center		Load sense, closed center	
Transmission Cooler Type	Variable displacement piston pump		Variable displacement piston pump	
Hydraulic System:	220 L/min	58 gpm	220 L/min	58 gpm
Type	Service Refill:		Service Refill:	
Pump Type	378 L	99.8 U.S. gal	378 L	99.8 U.S. gal
Pump Output	19 L	5.0 U.S. gal	19 L	5.0 U.S. gal
Service Refill:	27 L	7.1 U.S. gal	27 L	7.1 U.S. gal
Fuel Tank	57 L	15.1 U.S. gal	57 L	15.1 U.S. gal
DEF Tank*	54 L	14.3 U.S. gal	54 L	14.3 U.S. gal
Engine Oil	425 mL	14.4 oz	425 mL	14.4 oz
Cooling System	Differential, Final Drive:		Differential, Final Drive:	
Transmission, Torque Converter	Front	52 L	52 L	13.7 U.S. gal
Parking Brake	Rear	52 L	52 L	13.7 U.S. gal
Differential, Final Drive:	Hydraulic System:		Hydraulic System:	
Front	Tank	65 L	65 L	17.2 U.S. gal
Rear	Total	123 L	123 L	32.5 U.S. gal
Hydraulic System:				
Tank				
Total				

*Tier 4 Final/Stage IV/Japan 2014 (Tier 4 Final) equipped machines only.

MODEL	525D		535D	
Winch — Retrieval Winch:	Hydraulically driven		Hydraulically driven	
Type				
Maximum Line Pull — Bare Drum	178 kN	40,016 lbf	178 kN	40,016 lbf
Maximum Line Speed	41 m/min	134 ft/min	41 m/min	134 ft/min
Drum Diameter	229 mm	9"	229 mm	9"
Drum Width	254 mm	10"	254 mm	10"
Drum Capacity:				
19.0 mm (¾ in)	59 m	195'0"	59 m	195'0"
25.4 mm (1 in)	26 m	85'0"	26 m	85'0"
Winch — Logging Winch:	Hydraulically driven		Hydraulically driven	
Type				
Maximum Line Pull — Bare Drum	178 kN	40,016 lbf	178 kN	40,016 lbf
Maximum Line Speed	85.3 m/min	280 ft/min	85.3 m/min	280 ft/min
Drum Diameter	229 mm	9"	229 mm	9"
Drum Width	254 mm	10"	254 mm	10"
Drum Capacity:				
19.0 mm (¾ in)	59 m	195'0"	59 m	195'0"
25.4 mm (1 in)	26 m	85'0"	26 m	85'0"
MODEL	545D		555D	
Winch — Retrieval Winch:	Hydraulically driven		Hydraulically driven	
Type				
Maximum Line Pull — Bare Drum	178 kN	40,016 lbf	178 kN	40,016 lbf
Maximum Line Speed	41 m/min	134 ft/min	41 m/min	134 ft/min
Drum Diameter	229 mm	9"	229 mm	9"
Drum Width	254 mm	10"	254 mm	10"
Drum Capacity:				
19.0 mm (¾ in)	59 m	195'0"	59 m	195'0"
25.4 mm (1 in)	26 m	85'0"	26 m	85'0"
Winch — Logging Winch:	Hydraulically driven		Hydraulically driven	
Type				
Maximum Line Pull — Bare Drum	178 kN	40,016 lbf	178 kN	40,016 lbf
Maximum Line Speed	85.3 m/min	280 ft/min	85.3 m/min	280 ft/min
Drum Diameter	229 mm	9"	229 mm	9"
Drum Width	254 mm	10"	254 mm	10"
Drum Capacity:				
19.0 mm (¾ in)	59 m	195'0"	59 m	195'0"
25.4 mm (1 in)	26 m	85'0"	26 m	85'0"

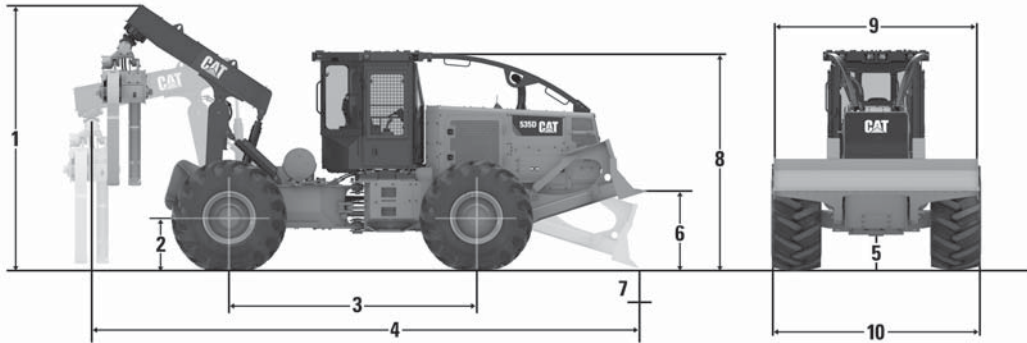

MODEL	525D	535D	545D	555D
1 Ground Level to Top Arch/Boom*				
Cable	2785 mm 109.6"	2785 mm 109.6"	2785 mm 109.6"	N/A
Single Function	3702 mm 145.8"	3702 mm 145.8"	N/A	N/A
Dual Function	4136 mm 162.8"	4136 mm 162.8"	4517 mm 177.8"	4517 mm 177.8"
2 Ground Level to Axle Center Line*	843 mm 33.2"	843 mm 33.2"	843 mm 33.2"	843 mm 33.2"
3 Wheelbase	3652 mm 143.8"	3796 mm 149.4"	3940 mm 155.1"	4083 mm 160.7"
4 Overall Length				
Cable	7297 mm 287.3"	7441 mm 292.9"	7585 mm 298.6"	N/A
Single Function	9051 mm 356.3"	9195 mm 361.9"	N/A	N/A
Dual Function	8322 mm 327.6"	8465 mm 333.3"	8827 mm 347.5"	9007 mm 354.6"
5 Ground Clearance*	550 mm 21.7"	550 mm 21.7"	550 mm 21.7"	550 mm 21.7"
6 Blade Lift Height*	1426 mm 56.1"	1426 mm 56.1"	1426 mm 56.1"	1426 mm 56.1"
7 Blade Dig Depth*	529 mm 20.8"	529 mm 20.8"	529 mm 20.8"	529 mm 20.8"
8 Height to Top of Cab*	3386 mm 133.3"	3386 mm 133.3"	3386 mm 133.3"	3386 mm 133.3"
9 Blade Width				
Standard	2678 mm 105.4"	2678 mm 105.4"	2678 mm 105.4"	2678 mm 105.4"
Wide	3138 mm 123.5"	3138 mm 123.5"	3138 mm 123.5"	3138 mm 123.5"
10 Overall Width				
30.5L-32 NOAW	3216 mm 126.6"	3216 mm 126.6"	3216 mm 126.6"	3216 mm 126.6"
30.5L-32 2X Ring	3216 mm 126.6"	3216 mm 126.6"	3216 mm 126.6"	3216 mm 126.6"
30.5L-32	3386 mm 133.3"	3386 mm 133.3"	3386 mm 133.3"	3386 mm 133.3"
35.5L-32 NOAW	3533 mm 139.1"	3533 mm 139.1"	3533 mm 139.1"	3533 mm 139.1"
35.5L-32	3703 mm 145.8"	3703 mm 145.8"	3703 mm 145.8"	3703 mm 145.8"
11 Weight**				
Cable	18 935 kg 41,745 lb	19 095 kg 42,097 lb	19 352 kg 42,665 lb	N/A
Single Function	20 065 kg 44,235 lb	20 305 kg 44,766 lb	N/A	N/A
Dual Function	20 525 kg 45,249 lb	20 766 kg 45,780 lb	21 190 kg 46,717 lb	21 540 kg 47,488 lb

*All heights based on 30.5L-32 tire, add 61 mm (2.4") for 35.5L-32 tires for dimensions 1, 2, 5, 6, and 8, subtract 61 mm (2.4") for 35.5L-32 tires for dimension 7.
 **Base Weight: 30.5L-32 20PR tires, grapple fenders, retrieval winch, water tank, wide blade.
 Deduct 227 kg (500 lb) for machines equipped with the Tier 3/Stage IIIA/Japan 2006 (Tier 3) equivalent Cat C7.1 ACERT™ engine.
 Deduct 2808 kg (6191 lb) for no tires; add 49 kg (108 lb) for 30.5L-32 26 PLY tires (required for 555D), 296 kg (653 lb) for 30.5L-32 2X ring, 628 kg (1385 lb) for 35.5L-32 20 PLY tires, 733 kg (1616 lb) for 35.5L-32 24 PLY tires.
 Deduct 97 kg (215 lb) for standard width blade.
 Deduct 239 kg (526 lb) for no grapple fenders (not applicable for cable configuration).
 Deduct 786 kg (1733 lb) for no retrieval winch; add 66 kg (146 lb) for logging winch (not applicable for cable configuration).

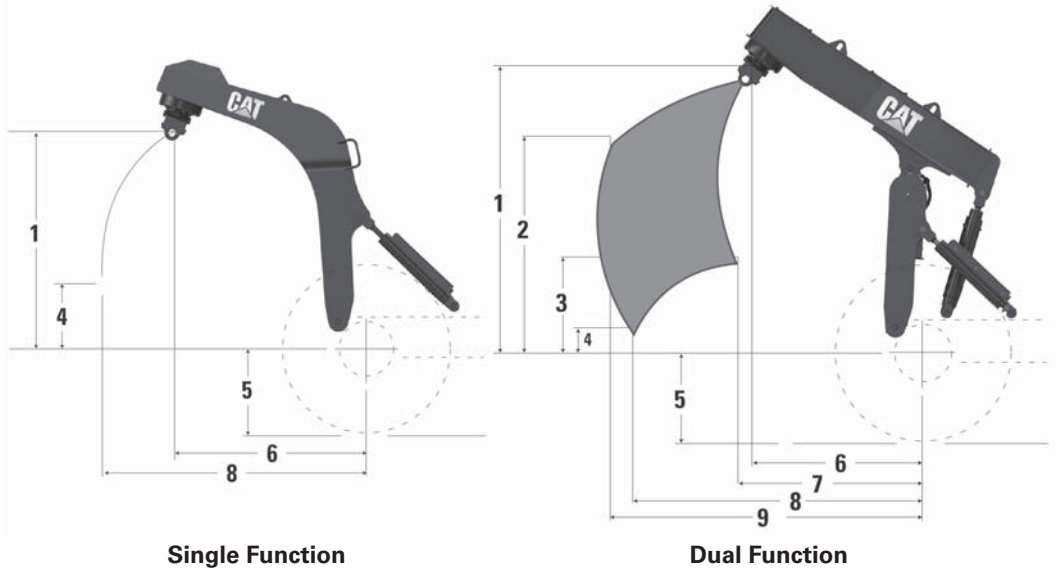

Single Function

Dual Function

MODEL	525D				535D			
	Single Function		Dual Function		Single Function		Dual Function	
1 Lift Height, Retracted	2208 mm	86.9"	2652 mm	104.4"	2208 mm	86.9"	2652 mm	104.4"
2 Lift Height, Furthest	N/A		1928 mm	75.9"	N/A		1928 mm	75.9"
3 Lift Lowest, Retracted	N/A		918 mm	36.1"	N/A		918 mm	36.1"
4 Lift Lowest, Furthest	596 mm	23.5"	280 mm	11.0"	596 mm	23.5"	280 mm	11.0"
5 Ground Level to Axle Center Line*	843 mm	33.2"	843 mm	33.2"	843 mm	33.2"	843 mm	33.2"
6 Reach Highest, Retracted	1786 mm	70.3"	1643 mm	64.7"	1786 mm	70.3"	1643 mm	64.7"
7 Reach Lowest, Retracted	N/A		1541 mm	60.7"	N/A		1541 mm	60.7"
8 Reach Lowest, Furthest	2668 mm	105.0"	2518 mm	99.1"	2668 mm	105.0"	2518 mm	99.1"
9 Reach Highest, Furthest	N/A		2917 mm	114.8"	N/A		2917 mm	114.8"

*Add 61 mm (2.4") for 35.5-32 tires.

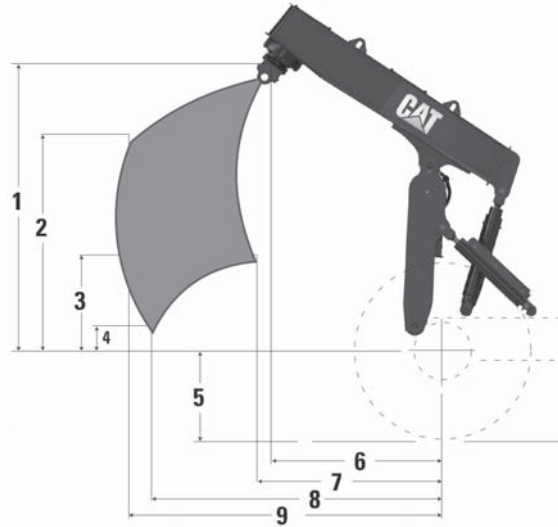

Dual Function

MODEL	545D		555D	
	Dual Function		Dual Function	
1 Lift Height, Retracted	3005 mm	118.3"	3005 mm	118.3"
2 Lift Height, Furthest	2200 mm	86.6"	2200 mm	86.6"
3 Lift Lowest, Retracted	1125 mm	44.3"	1125 mm	44.3"
4 Lift Lowest, Furthest	379 mm	14.9"	379 mm	14.9"
5 Ground Level to Axle Center Line*	843 mm	33.2"	843 mm	33.2"
6 Reach Highest, Retracted	1626 mm	64.0"	1626 mm	64.0"
7 Reach Lowest, Retracted	1883 mm	74.1"	1883 mm	74.1"
8 Reach Lowest, Furthest	2863 mm	112.7"	2863 mm	112.7"
9 Reach Highest, Furthest	3007 mm	118.4"	3007 mm	118.4"

*Add 61 mm (2.4") for 35.5-32 tires.

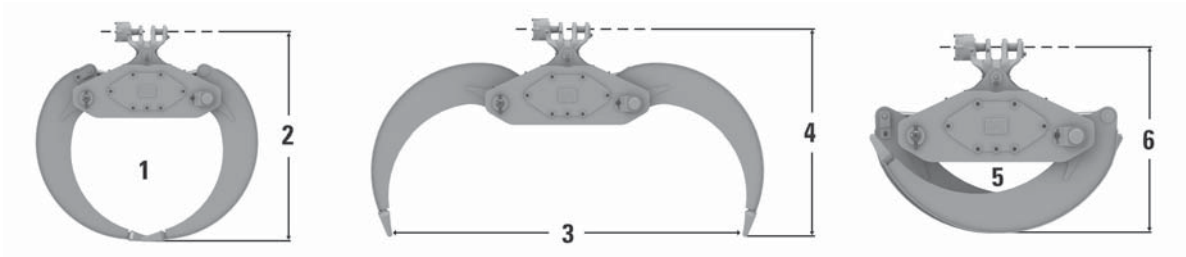

MODEL	525D		535D		545D		555D	
1 Grapple Capacity	1.34 m ²	14.4 ft²	1.54 m ²	16.6 ft²	1.77 m ²	19.0 ft²	2.04 m ²	22.0 ft²
2 Tip to Tip Height	2083 mm	82.0"	2108 mm	83.0"	2159 mm	85.0"	2367 mm	93.19"
3 Tong Opening	3205 mm	126.2"	3226 mm	127.0"	3429 mm	135.0"	3652 mm	143.78"
4 Fully Open Height	1811 mm	71.3"	1905 mm	75.0"	1880 mm	74.0"	1998 mm	78.66"
5 Minimum Stem Diameter	176 mm	6.9"	183 mm	7.2"	241 mm	9.5"	305 mm	12.01"
6 Fully Closed Height	1382 mm	54.4"	1371 mm	54.0"	1473 mm	58.0"	1577 mm	62.09"

Introduction

The Cat 527 Skidder is designed and built specifically for log skidding applications. The 527's extended track roller frame and weight-forward bias make it well suited for mountainous and soft underfoot logging operations. The skidder's ergonomic and spacious operator's environment allow for increased comfort and production. The 527's standard forestry guarding and undercarriage design ensure the durability required in logging applications. Both Cable and Swing-boom Grapple configurations are provided to suit a wide range of skidding applications.

Features 527:

- **Field proven Cat 3304 diesel engine** sets the industry standard for reliability and durability, delivering high horsepower for more drawbar pull, improved skidding performance and ease of operation.
- **Large, heavy duty torque converter**, reduces the tendency for track-to-ground slip, reduces the need for up and downshifting and protects power train components contributing to longer component life.
- **3 speed planetary powershift transmission** works best in high-pull applications and is well suited for large load and steep terrain skidding.
- **Heavy-duty track roller frame** extended to the rear significantly improves traction capability under heavy loads and uphill skidding applications.
- **Wide gauge and long track roller frames** provide outstanding sidehill stability.
- **Improved flotation** — More track on the ground distributes tractor weight and propulsion forces over a much larger area than conventional track skidders. This improves flotation capabilities, gradeability and significantly reduces soil impact.
- **Load sensing hydraulic system** — Variable displacement pressure compensating hydraulic system provides reduced power requirements when there is not hydraulic demand, significantly reduced heat generation, and improving fuel efficiency.
- **Auto-grab feature** — provides constant grapple tong pressure without continuous hydraulic pump demand.
- **Superior component durability** — Final drives are raised above the work area, isolating the power train from ground impact shock and abrasive materials.
- **Excellent ground clearance** — no diagonal braces allow the skidder to pass over stumps and debris, reduces maneuvering for reduced cycle times and minimizes soil impact.
- **Smooth belly pans** — Less likely to hang up in mud and debris in soft ground or swamp logging applications.
- **Easy and comfortable operating environment** — The seat is angled and controls are easily reached to reduce operator fatigue and increase productivity. Optional enclosed ROPS/FOPS cab allows excellent front and rear viewing, and is pressurized for sound level reduction.
- **Single lever** grapple control and blade control.
- **Less service time** — Major components are made as modules and most can be removed without removing others, and ground-level access provides convenient servicing to most filters and lube points.
- **Cable and Swing Boom** configurations provide the versatility needed to match the skidder to a wide variety of skidding applications.

MODEL	527 Cable		527 Grapple	
Gross Power (ISO 14396)	124 kW	166 hp	124 kW	166 hp
Operating Weight*	18 720 kg	41,270 lb	21 900 kg	48,281 lb
Engine Model	3304 DIT		3304 DIT	
Rated Engine RPM	2200		2200	
Bore	120.65 mm	4.75"	120.65 mm	4.75"
Stroke	152.4 mm	6"	152.4 mm	6"
Displacement	7 L	425 in³	7 L	425 in³
No. of Cylinders	4		4	
Speeds Forward:				
1st	3.7 km/h	2.3 mph	3.7 km/h	2.3 mph
2nd	6.6 km/h	4.1 mph	6.6 km/h	4.1 mph
3rd	11.5 km/h	7.1 mph	11.5 km/h	7.1 mph
Speeds Reverse:				
1st	4.6 km/h	2.8 mph	4.6 km/h	2.8 mph
2nd	8.3 km/h	5.1 mph	8.3 km/h	5.1 mph
3rd	14.6 km/h	9.0 mph	14.6 km/h	9.0 mph
Track Roller Frame	7		8	
Width of Standard Track Shoe	560 mm	22"	760 mm	30"
Track Gauge	2160 mm	85"	2160 mm	85"
General Dimensions:				
Height (To Top of ROPS)	3298 mm	129.8"	3298 mm	129.8"
Overall Length:				
With Blade and Winch	5224 mm	205.67"	—	
With Blade and Maximum Boom Reach	—		8166 mm	321.5"
With Blade and Minimum Boom Reach	—		6137 mm	241.6"
Width (without Trunnion)	2720 mm	107"	2720 mm	107"
Ground Clearance	711.2 mm	28"	711.2 mm	28"
Capacity:				
Fuel Tank	284 L	75 U.S. gal	284 L	75 U.S. gal

*All models include coolant, lubricants, full fuel tank, and operator.

527 Cable includes lubricants, coolant, ROPS canopy, 100% fuel, operator, 5P blade, open cab, and towing winch.

527 Grapple includes lubricants, coolant, ROPS canopy, 100% fuel, operator, 5P blade, track roller guard, 760 mm (30") tri-link track, swing grapple, 2.54 m (100") sorting head, and enclosed cab.

**With 22 mm (0.88") cable.

Shoe Selection and Ground Pressure

MODEL	527 (7-roller track frame)		527 (8-roller track frame)	
	Number of Shoes (each side)	41		43
Width of Shoes	560 mm	22"	—	
	610 mm	24"	—	
	760 mm	30"	760 mm	30"
Length of Track on Ground	2846 mm	112"	3061 mm	121"
Track Gauge	2160 mm	85"	2160 mm	85"
Ground Contact Area with:				
560 mm (22") Shoes	3.18 m ²	4928 in ²	—	
610 mm (24") Shoes	3.47 m ²	5376 in ²	—	
760 mm (30") Tri-link	4.33 m ²	6705 in ²	4.65 m ²	7208 in ²
Ground Pressure (Grapple):				
760 mm (30") Tri-link	—		0.47 kg/cm ²	6.70 psi
Ground Pressure (Cable):				
560 mm (22") Shoes	0.59 kg/cm ²	8.37 psi	—	
610 mm (24") Shoes	0.54 kg/cm ²	7.74 psi	—	
760 mm (30") Shoes	0.46 kg/cm ²	6.74 psi	—	

Winch Specifications

MODEL	527 Cable	
Maximum Line Pull	93 822 N·m	69,200 lb
Maximum Line Speed	43.6 m/min	143 fpm
Drum Capacity:		
Recommended	122 m	400'0"
Cable Size:		
Recommended	19 mm	0.75"
Drum Diameter	254 mm	10.0"
Drum Width	330 mm	13.0"
Weight	1497 kg	3300 lb

Blade Specifications

MODEL	5P-PAT		527 PAT	
Blade Width — Straight	3272 mm	128.82"	3460 mm	136.22"
Blade Height	1200 mm	47.24"	922 mm	36.30"
Blade Capacity*	3.77 m ³	4.93 yd ³	2.35 m ³	3.07 yd ³

*Blade capacity calculated per ISO 9246 Engineering Standard for Determination of Dozer Volume Capacity.

MACHINE DIMENSIONS (All dimensions are approximate.)

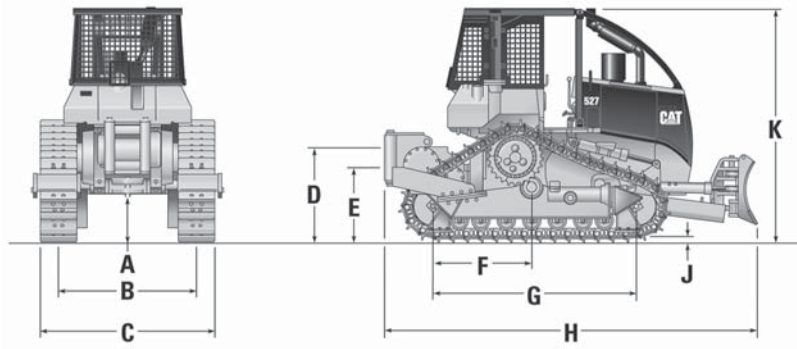

MODEL

527 Cable

MODEL	527 Cable	
A Ground Clearance	712 mm	28"
B Track Gauge	2160 mm	85"
C Shipping Width*	2720 mm	107"
D Height to Top of Drum	1339 mm	53"
E Height to Center of Drum	1048 mm	41"
F Pivot Shaft to Rear Idler**	1380 mm	54"
G Length of Track on Ground**	2846 mm	112"
H Shipping Length	5224 mm	205.67"
J Grouser Height	65 mm	2.6"
K Shipping Height	3298 mm	129.8"

*With 560 mm (22") Track Shoes.

**With 7-Roller Track Frame.

MACHINE DIMENSIONS (All dimensions are approximate.)

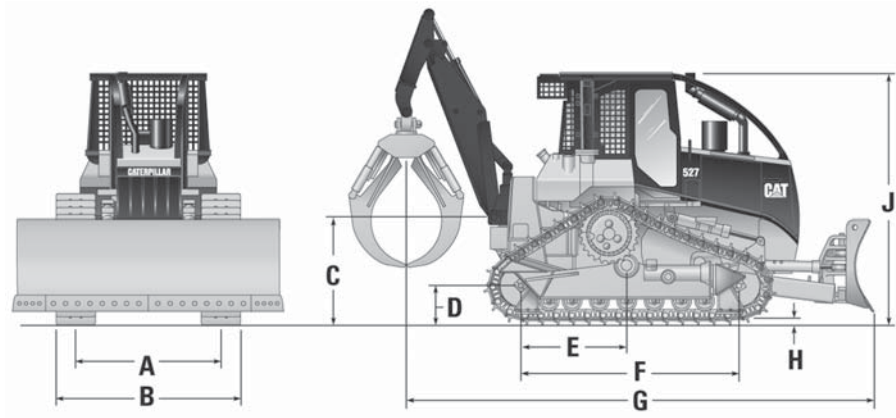

MODEL

527 Swing Boom

A Track Gauge	2160 mm	85"
B Shipping Width*	3020 mm	118.9"
C Height to Swing Boom Pivot Pin	1408 mm	55"
D Height to Center of Idlers	452 mm	18"
E Pivot Shaft to Rear Idler**	1595 mm	62.8"
F Length of Track on Ground**	3061 mm	121"
G Overall Length — Boom Retracted	6137 mm	241.6"
Overall Length — Boom Extended (not shown)	8166 mm	321.5"
H Grouser Height	65 mm	2.6"
J Shipping Height	3298 mm	129.8"

*With 760 mm (30") Track Shoes.

**With 8-Roller Track Frame.

527 SKIDDER

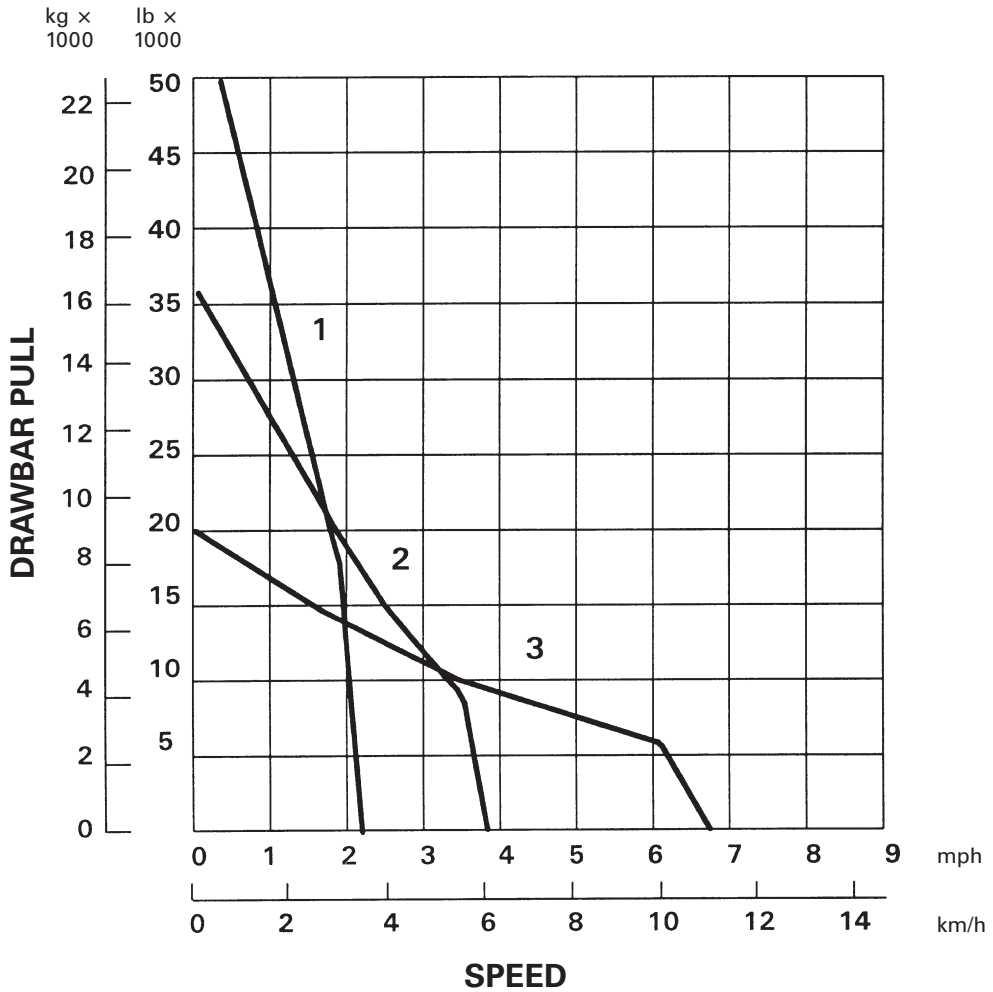

- KEY**
- 1 – 1st Gear
 - 2 – 2nd Gear
 - 3 – 3rd Gear

NOTE: Usable pull will depend upon weight and traction of equipped tractor.

BOOM AND GRAPPLES

The following contains information on some of the available models, which are presented here to suggest a range of grapple possibilities.

Reach (A, B) — The horizontal distance from the vertical center of the rear idler to the vertical center of the grapple fore and aft pivot.

- A) With the grapple in its lowest fully extended position.
- B) With the grapple in its highest fully retracted position.

Lift (C, D, E) — The vertical distance from the ground to the center of the grapple fore and aft pivot.

- C) With the grapple in its highest fully extended position.
- D) With the grapple in its highest fully retracted position.
- E) With the grapple in its lowest fully extended position.

Maximum Grapple Opening (K) — The horizontal distance between the tips of the grapple arms when grapple is fully open.

Area of Opening (L) — The available area with grapple in tips together position.

Minimum Log Size (M) — The smallest diameter which the grapple can close.

Grapple Length (N, O, P) — The distance from the grapple fore and aft pivot to tips of grapple arms.

- N) With grapple fully open.
- O) With grapple in tips together position.
- P) With grapple fully closed.

Bunching Grapple

- Used for 305 mm (12") or smaller diameter trees.
- Designed to gather bundle of stems and maximize grapple loads.

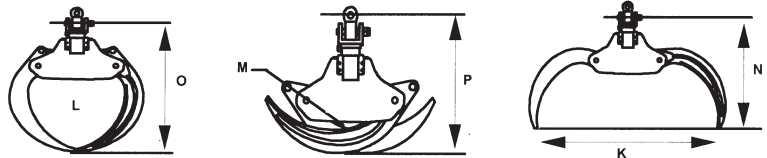

Grapples for 527	K	L	M	N	O	P
2.79 m (110") Bunching	2794 mm 110"	0.93 m ² 10 ft ²	76 mm 3"	1780 mm 70"	2020 mm 79.5"	1360 mm 53.5"

Swing-boom

- Ability to reach and lift over the side to collect scattered logs.
- Has decking and loading capability.
- Excellent reach to the rear and side for maximum skidder versatility.
- Suitable for hard to reach timber on steep slopes, soft ground, or selection harvest and thinning.
- Reduces cycle times by reducing the amount of maneuvering of the skidder to reach logs.

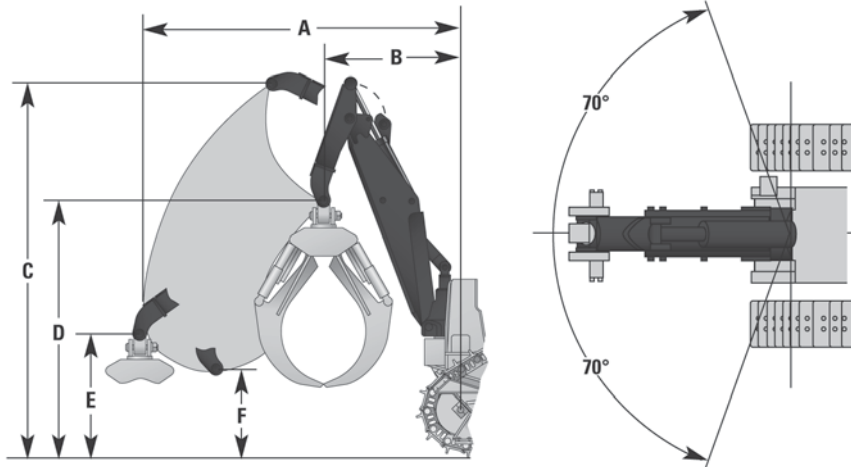

Swing-boom		A	B	C	D	E	F
527	mm	3329	1301	4084	2792	1358	933.5
	in	131.1	51.2	160.8	109.9	53.5	36.8

Sustainability:

- **Major structures and components** are built to be rebuilt, reducing waste and replacement costs.
- **ACERT Technology** reduces engine emissions at point of combustion with less moving parts for lower operating costs.

564/574 Features:

- **Field-proven Cat engines with ACERT Technology**, along with a torque converter power shift transmission. The engines meet Tier 3/Stage IIIA/Japan 2006 (Tier 3) equivalent emission standards. Flex engines are available for HRC regions.
- **Large high visibility cab** with scratch resistant 1.27 cm (0.5 in) tinted polycarbonate windows and side windows with escape.

- **Hydraulic tilt** gives complete under cab service access.
- **Extra heavy frame** with full 40 degree articulation for tight turning.
- **Purpose-built blade** with wear resistant front cutting edge.
- **Rear mounted loader** with durable rack and pinion swing system.
- **Full load high reach boom.**
- **250 degree rotation.**
- **European style butt-bypass clam** built with high strength steel dampener.

MODEL	564 (6-wheel)		574 (8-wheel)	
Gross Power (ISO 14396)	129 kW	173 hp	129 kW	173 hp
Operating Weight	16 330 kg	36,000 lb	17 237 kg	38,000 lb
Engine Model	C6.6 ACERT		C6.6 ACERT	
Emission Standards	Tier 3/Stage IIIA/ Japan 2006 (Tier 3) equivalent		Tier 3/Stage IIIA/ Japan 2006 (Tier 3) equivalent	
Maximum Forward Speed	23.3 km/h	14.5 mph	23.3 km/h	14.5 mph
Loader Reach	6.9 m	22'9"	6.9 m	22'9"
Load Capacity	13 608 kg	30,000 lb	14 525 kg	32,000 lb
Fuel Capacity	178 L	47 U.S. gal	178 L	47 U.S. gal
Transmission	Electric Powershift		Electric Powershift	
General Dimensions:				
Wheelbase	5334 mm	210"	5334 mm	210"
Ground Clearance	579 mm	22.8"	579 mm	22.8"

Sustainability:

- **Major structures and components** are built to be rebuilt, reducing waste and replacement costs.
- **ACERT Technology** reduces engine emissions at point of combustion with less moving parts for lower operating costs.
- **Speed modulated hydraulically driven cooling fan** for decreased power requirements resulting in reduced fuel consumption.
- **1800 RPM engine** for reduced engine speeds to provide increased fuel economy.

584/584HD Features:

- **Cat C7 ACERT engine** with 1800 RPM rating and excellent torque in the 1400 to 1600 RPM range for increased fuel efficiency. The engines meet Tier 3/ Stage IIIA/Japan 2006 (Tier 3) equivalent emission standards suitable for LRC regions.
- **Enlarged hydraulic cooling capacity** to provide high heat rejection capability for extended component life.
- **Hydraulic driven cooling fan** with speed modulation for reduced fuel consumption and maintaining optimal system temperatures for better component performance.

- **Hydrostatic drive system** for infinitely variable speed at peak power and dynamic braking for steep terrain.
- **8.5C drive line components** provide superior strength and service life for reduced maintenance costs.
- **Robust front and rear frame structures** provide the ability to rebuild/relife to reduce overall ownership costs and increase resale values.
- **Heavy duty cast articulation and large oscillation bearing** designed to provide a long service life.
- **Ergonomic cab** with automatic temperature control, air suspension seat, storage compartments, and low effort joy stick controls.
- **Drop down side window** design for enhanced visibility to the work area close to the machine and in front of all wheels.
- **Front entry door** provides easy access off of a hydraulic lift stairway and platform.
- **Forward tilting engine hood and hydraulic tilt cab** for easy service access.

MODEL	584 (6-wheel)		584HD (8-wheel)	
Gross Power (ISO 14396)	204 kW	274 hp	204 kW	274 hp
Operating Weight	20 230 kg	44,600 lb	23 088 kg	50,900 lb
Engine Model	C7 ACERT		C7 ACERT	
Emission Standards	Tier 3/Stage IIIA/ Japan 2006 (Tier 3) equivalent		Tier 3/Stage IIIA/ Japan 2006 (Tier 3) equivalent	
Maximum Tractive Force	210 kN	47,169 lb-f	226 kN	50,864 lb-f
Maximum Speed	22.5 km/h	14.0 mph	20.9 km/h	13.0 mph
STD Loader Reach	8.0 m	26.25 ft	8.0 m	26.25 ft
Loader Lifting Torque (gross)	159 kN·m	111,975 lb-ft	159 kN·m	111,975 lb-ft
Load Capacity	18 000 kg	39,683 lb	20 000 kg	44,092 lb
Fuel Capacity	255 L	67.3 U.S. gal	255 L	67.3 U.S. gal
Transmission	2 speed hydrostatic		2 speed hydrostatic	
General Dimensions:				
Wheelbase	6096 mm	240"	6096 mm	240"
Bogie Spread (center to center)	1690 mm	66.5"	1690 mm	66.5"
Ground Clearance	692 mm	27.3"	692 mm	27.3"

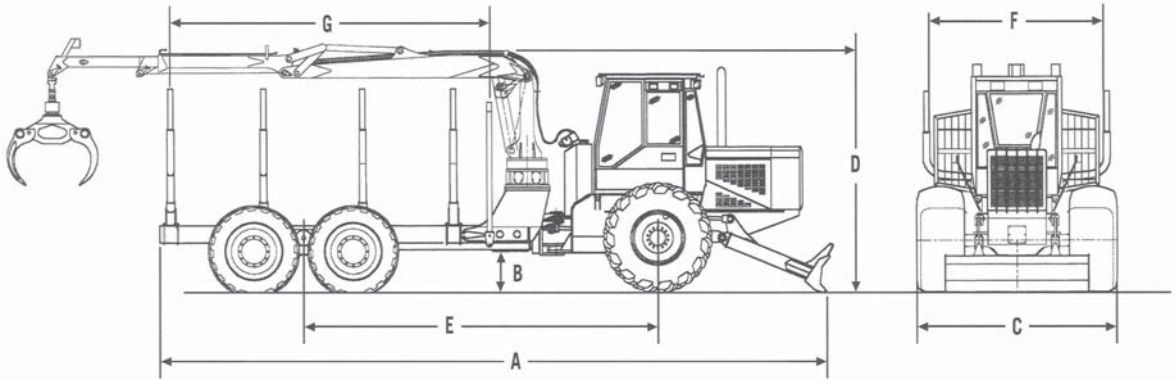

MODEL	564 (6-wheel)		574 (8-wheel)	
A Length with:				
4.88 m (16') Load Deck	10 210 mm	402"	10 210 mm	402"
5.64 m (18.5') Load Deck	10 970 mm	432"	10 970 mm	432"
B Ground Clearance	579 mm	22.8"	579 mm	22.8"
C Width with Standard Tires	2997 mm	118"	3048 mm	120"
D Transport Height	3581 mm	141"	3581 mm	141"
E Wheelbase with:				
4.88 m (16') Load Deck	5334 mm	210"	5334 mm	210"
5.64 m (18.5') Load Deck	5715 mm	225"	5715 mm	225"
F Load Stake Width (Inside)	2591 mm	102"	2591 mm	102"
G Length of Standard Wood Bunk	4880 mm	16'	4880 mm	16'
Optional Length 1	5640 mm	18.5'	5640 mm	18.5'
Optional Length 2		—		—

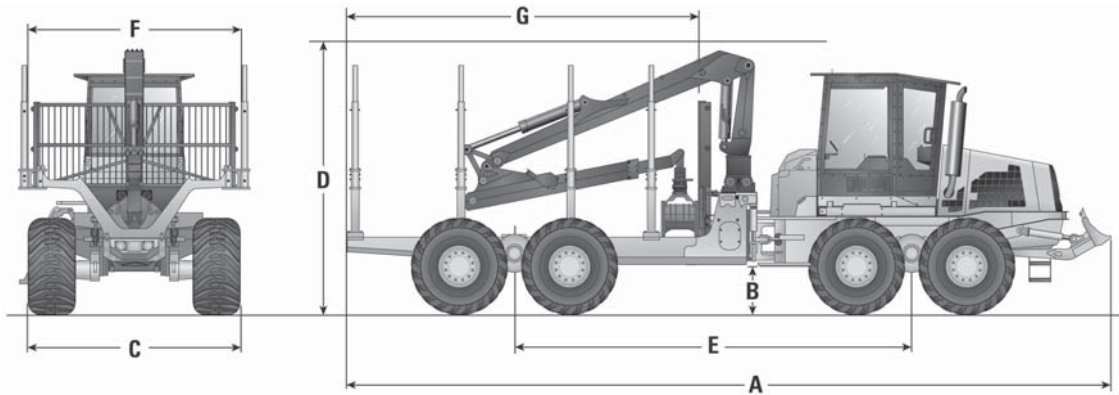

MODEL	584 (6-wheel)		584HD (8-wheel)	
A Length with Blade	11 755 mm	463"	11 755 mm	463"
B Ground Clearance	692 mm	27.3"	692 mm	27.3"
C Width with Standard Tires	3180 mm	125.2"	3180 mm	125.2"
D Transport Height	4163 mm	163.9"	4163 mm	163.9"
E Wheelbase	6096 mm	240"	6096 mm	240"
F Load Stake Width (Inside) with:				
Standard Bunk	2769 mm	109"	2769 mm	109"
Optional Bunk	3264 mm	128.5"	3264 mm	128.5"
G Length of Wood Bunk	5410 mm	213"	5410 mm	213"

Lift Capacities

Model	3m	4m	5m	6m	7m	8m	Unit
X120F80	3700	2770	2210	1840	1570	1360	kg
	8157	6107	4872	4057	3461	2998	lb
	3	4	5	6	7	8	m
	9'10"	13'1"	16'5"	19'8"	23'0"	26'3"	ft/in

Introduction

Cat forestry machines are specifically designed for tough forest work. Each model uses purpose built booms, sticks and grapples designed by Caterpillar for maximum performance and durability.

The following information provides features, specifications, dimensions, working ranges and major component weights for the 320D FM, 324D FM, 325D FM and 568 FM.

Features

320D FM

- **The Cat C6.4 ACERT engine** provides power, low emissions, outstanding reliability, and maximizes fuel economy. Meets Tier 3/Stage IIIA/Japan 2006 (Tier 3) equivalent emission standards.
- **Various configurations** for demanding applications including Harvester, Log Loader, Slasher, Road Builder, Thumb, Grapple Saw, AEM Delimber carrier and Processor.
- **Rugged undercarriage design and proven structural components** provide outstanding durability.
- **Track roller frames** are robot-welded and pressed formed, pentagonal units to deliver exceptional strength and service life.
- **Undercarriage** — Forestry machine configuration options allow you to choose the right machine for your application.
- **Operator station** — Redesigned interior layout maximizes operator space, provides exceptional comfort and reduces operator fatigue.
- **Serviceability** — Longer service intervals and easier maintenance result in better machine availability and lower costs.

324D FM/325D FM

- **Cat C7 ACERT engine** provides exceptional power and fuel efficiency. Meets Tier 3/Stage IIIA/Japan 2006 (Tier 3) equivalent emission standards.
- **Attachments** — Factory installed Log Loader fronts with Live Heel and Cat Grapples; Harvester, Road Builder and Butt-n-Top fronts; AEM delimber carrier options help meet diverse forest applications.
- **Cat GLL forestry grapples**, built with high-grade steel throughout the grapple, matched with Cat Forest Machines provide high performance and reliability in logging applications.

- **Rugged main frame design** is purpose-built for forest applications with reinforced carbody, rugged swing bearing, heavy doors and extra guarding.
- **Undercarriage** — Both 324D FM and 325D FM feature new Lowers with heavier undercarriage components, 9 roller track frames, and improved machine stability.
- **Operator station** — Interior layout maximizes operator space and provides exceptional comfort. Cab has excellent sightlines to the work area. A less-off cab version is also available for AEM special cab installations.
- **Serviceability** — Simplified service and maintenance, and electronic diagnostics help save time, money and increase productivity.

568 FM

- **Cat C9.3 ACERT engine** provides exceptional power and fuel efficiency, meeting Tier 4 Interim/Stage IIIB/Japan 2011 (Tier 4 Interim) equivalent emission standards.
- **Attachments** — Factory installed Log Loader fronts with Live Heel and Cat Grapples; Harvester, Road Builder and Butt-n-Top fronts; help meet diverse forestry applications.
- **Cat GLL forestry grapples**, built with high-grade steel throughout the grapple, matched with Cat Forest Machines provide high performance and reliability in logging applications.
- **Reinforced carbody design** stands up to the most demanding forest applications, assuring outstanding durability and service life.
- **Undercarriage** — Heavy-duty link assemblies provide toughness and durability, maximizing undercarriage life and minimizing operating costs. Long 10 roller track frames provide excellent machine stability and maneuverability on steep slopes.
- **Guarding** — Purpose designed guarding helps extend service life, reduces downtime and helps protect your forestry machine investment.
- **Operator station** — Spacious, quiet, automatically climate controlled cab has excellent sightlines to the work area. A less-off cab version is also available for AEM special cab installations.
- **Serviceability** — Simplified service and maintenance, and electronic diagnostics help save time, money and increase productivity.

MODEL	320D FM General Forestry (HD/LC)		320D FM General Forestry (HW)		320D FM Log Loader (U/U)	
Net Flywheel Power (SAE J1349)	110 kW	147 hp	110 kW	147 hp	110 kW	147 hp
Operating Weight	25 500 kg	56,228 lb	26 900 kg	59,315 lb	30 300 kg	66,812 lb
Swing Mechanism:						
Torque	61.8 kN·m	45,611 lb-ft	61.8 kN·m	45,611 lb-ft	61.8 kN·m	45,611 lb-ft
Speed	11.5 RPM		11.5 RPM		11.5 RPM	
Engine Model	C6.4 ACERT		C6.4 ACERT		C6.4 ACERT	
Emission Standards	Tier 3/Stage IIIA/ Japan 2006 (Tier 3) equivalent		Tier 3/Stage IIIA/ Japan 2006 (Tier 3) equivalent		Tier 3/Stage IIIA/ Japan 2006 (Tier 3) equivalent	
No. of Cylinders	6		6		6	
Bore	102 mm	4"	102 mm	4"	102 mm	4"
Stroke	130 mm	5.1"	130 mm	5.1"	130 mm	5.1"
Displacement	6.4 L	390 in³	6.4 L	390 in³	6.4 L	390 in³
Hydraulic System:						
Main Implement System — Maximum Flow (2X)	205 L/min	54.2 gpm	205 L/min	54.2 gpm	205 L/min	54.2 gpm
Relief Valve Settings:						
Implement Circuits	35 000 kPa	5075 psi	35 000 kPa	5075 psi	35 000 kPa	5075 psi
Travel Circuits	35 000 kPa	5075 psi	35 000 kPa	5075 psi	35 000 kPa	5075 psi
Swing Circuits	25 000 kPa	3625 psi	25 000 kPa	3625 psi	25 000 kPa	3625 psi
Pilot Circuits	4120 kPa	600 psi	4120 kPa	600 psi	4120 kPa	600 psi
Drive:						
Maximum Drawbar Pull	188 kN	42,264 lb	248 kN	55,700 lb	248 kN	55,700 lb
Maximum Travel Speed	5.3 km/h	3.3 mph	4.3 km/h	2.6 mph	4.3 km/h	2.6 mph
Log Loader Linkage:						
Boom Cylinder — Bore	140 mm	5.5"	140 mm	5.5"	140 mm	5.5"
Boom Cylinder — Stroke	1160 mm	45.7"	1160 mm	45.7"	1160 mm	45.7"
Stick Cylinder — Bore	150 mm	5.9"	150 mm	5.9"	150 mm	5.9"
Stick Cylinder — Stroke	1470 mm	57.9"	1470 mm	57.9"	1470 mm	57.9"
Under/Under Heel Cylinder — Bore	—		—		130 mm	5.1"
Under/Under Heel Cylinder — Stroke	—		—		1156 mm	45.5"
Track:						
Standard (HD double grouser)	700 mm	28"	700 mm	28"	700 mm	28"
Optional (HD double grouser)	600 mm	24"	600 mm	24"	600 mm	24"
Optional (HD triple grouser)	700 mm	28"	700 mm	28"	700 mm	28"
Optional (HD triple grouser)	—		800 mm	32"	800 mm	32"
Overall Track Length	4480 mm	14'8"	4555 mm	14'11"	4555 mm	14'11"
Ground Clearance	475 mm	1'7"	650 mm	2'2"	650 mm	2'2"
Track Gauge	2380 mm	7'10"	2590 mm	8'6"	2590 mm	8'6"
Capacity:						
Fuel Tank	410 L	108.3 U.S. gal	410 L	108.3 U.S. gal	410 L	108.3 U.S. gal
Fuel Tank (optional auxiliary right front)	410 L	108.3 U.S. gal	410 L	108.3 U.S. gal	410 L	108.3 U.S. gal
Cooling System	25 L	6.6 U.S. gal	—		25 L	6.6 U.S. gal
Engine Oil	30 L	7.9 U.S. gal	30 L	7.9 U.S. gal	30 L	7.9 U.S. gal
Swing Drive	8 L	2.1 U.S. gal	—		8 L	2.1 U.S. gal
Hydraulic System — Total	260 L	68.7 U.S. gal	260 L	68.7 U.S. gal	260 L	68.7 U.S. gal
Hydraulic System — Tank	125 L	33.0 U.S. gal	125 L	33.0 U.S. gal	125 L	33.0 U.S. gal
Final Drive (each)	10 L	2.6 U.S. gal	13 L	3.4 U.S. gal	13 L	3.4 U.S. gal

MODEL	324D FM General Forestry (HW)		324D FM Log Loader (U/U)		324D FM Log Loader (O/U)	
Net Flywheel Power (SAE J1349)	140 kW	188 hp	140 kW	188 hp	140 kW	188 hp
Operating Weight (with front linkage, without bucket or grapple)	32 105 kg	70,631 lb	34 975 kg	76,945 lb	35 115 kg	77,253 lb
Swing Mechanism:						
Torque	84.5 kN·m	62,300 lb-ft	84.5 kN·m	62,300 lb-ft	84.5 kN·m	62,300 lb-ft
Speed	10 RPM		10 RPM		10 RPM	
Engine Model	C7 ACERT		C7 ACERT		C7 ACERT	
Emission Standards	Tier 3/Stage IIIA/ Japan 2006 (Tier 3) equivalent		Tier 3/Stage IIIA/ Japan 2006 (Tier 3) equivalent		Tier 3/Stage IIIA/ Japan 2006 (Tier 3) equivalent	
No. of Cylinders	6		6		6	
Bore	110 mm	4.3"	110 mm	4.3"	110 mm	4.3"
Stroke	127 mm	5"	127 mm	5"	127 mm	5"
Displacement	7.2 L	440 in³	7.2 L	440 in³	7.2 L	440 in³
Hydraulic System:						
Main Implement System — Maximum Flow (2X)	220 L/min	58.1 gpm	220 L/min	58.1 gpm	220 L/min	58.1 gpm
Relief Valve Settings:						
Implement Circuits	35 000 kPa	5075 psi	35 000 kPa	5075 psi	35 000 kPa	5075 psi
Travel Circuits	35 000 kPa	5075 psi	35 000 kPa	5075 psi	35 000 kPa	5075 psi
Swing Circuits	24 500 kPa	3553 psi	24 500 kPa	3553 psi	24 500 kPa	3553 psi
Pilot Circuits	3920 kPa	568 psi	3920 kPa	568 psi	3920 kPa	568 psi
Drive:						
Maximum Drawbar Pull	259 kN	58,226 lb	259 kN	58,226 lb	259 kN	58,226 lb
Maximum Travel Speed	5.7 km/h	3.5 mph	5.7 km/h	3.5 mph	5.7 km/h	3.5 mph
Log Loader Linkage:						
Boom Cylinder — Bore	140 mm	5.5"	140 mm	5.5"	140 mm	5.5"
Boom Cylinder — Stroke	1185 mm	46.7"	1185 mm	46.7"	1185 mm	46.7"
Stick Cylinder — Bore	170 mm	6.7"	170 mm	6.7"	170 mm	6.7"
Stick Cylinder — Stroke	1680 mm	66.1"	1680 mm	66.1"	1680 mm	66.1"
Under/Under Heel Cylinder — Bore	—	—	130 mm	5.1"	—	—
Under/Under Heel Cylinder — Stroke	—	—	1156 mm	45.5"	—	—
Over/Under Heel Cylinder — Bore	—	—	—	—	150 mm	5.9"
Over/Under Heel Cylinder — Stroke	—	—	—	—	1470 mm	57.9"
Track:						
Standard (HD double grouser)	700 mm	28"	700 mm	28"	700 mm	28"
Optional (double grouser)	600 mm	24"	600 mm	24"	600 mm	24"
Optional (HD triple grouser)	850 mm	34"	850 mm	34"	850 mm	34"
Overall Track Length	4967 mm	16'4"	4967 mm	16'4"	4967 mm	16'4"
Ground Clearance	743 mm	2'5"	743 mm	2'5"	743 mm	2'5"
Track Gauge	2920 mm	9'7"	2920 mm	9'7"	2920 mm	9'7"
Capacity:						
Fuel Tank (standard)	520 L	137.4 U.S. gal	520 L	137.4 U.S. gal	520 L	137.4 U.S. gal
Fuel Tank (optional auxiliary right front)	410 L	108.3 U.S. gal	410 L	108.3 U.S. gal	410 L	108.3 U.S. gal
Cooling System	30 L	7.9 U.S. gal	30 L	7.9 U.S. gal	30 L	7.9 U.S. gal
Engine Oil	34 L	9.0 U.S. gal	34 L	9.0 U.S. gal	34 L	9.0 U.S. gal
Swing Drive	8 L	2.1 U.S. gal	8 L	2.1 U.S. gal	8 L	2.1 U.S. gal
Hydraulic System — Total	245 L	64.7 U.S. gal	245 L	64.7 U.S. gal	245 L	64.7 U.S. gal
Hydraulic System — Tank	145 L	38.3 U.S. gal	145 L	38.3 U.S. gal	145 L	38.3 U.S. gal
Final Drive (each)	8 L	2.1 U.S. gal	8 L	2.1 U.S. gal	8 L	2.1 U.S. gal

MODEL	325D FM General Forestry (HW)		325D FM Log Loader (U/U)		325D FM Log Loader (O/U)	
Net Flywheel Power (SAE J1349)	152 kW	204 hp	152 kW	204 hp	152 kW	204 hp
Operating Weight (with front linkage, without bucket or grapple)	36 951 kg	81,466 lb	41 430 kg	91,338 lb	41 834 kg	92,229 lb
Swing Mechanism:						
Torque	99.3 kN·m	73,213 lb-ft	99.3 kN·m	73,213 lb-ft	99.3 kN·m	73,213 lb-ft
Speed		10 RPM		10 RPM		10 RPM
Engine Model		C7 ACERT		C7 ACERT		C7 ACERT
Emission Standards		Tier 3/Stage IIIA/ Japan 2006 (Tier 3) equivalent		Tier 3/Stage IIIA/ Japan 2006 (Tier 3) equivalent		Tier 3/Stage IIIA/ Japan 2006 (Tier 3) equivalent
No. of Cylinders		6		6		6
Bore	110 mm	4.3"	110 mm	4.3"	110 mm	4.3"
Stroke	127 mm	5"	127 mm	5"	127 mm	5"
Displacement	7.2 L	440 in³	7.2 L	440 in³	7.2 L	440 in³
Hydraulic System:						
Main Implement System — Maximum Flow (2X)	235 L/min	62.1 gpm	235 L/min	62.1 gpm	235 L/min	62.1 gpm
Relief Valve Settings:						
Implement Circuits	35 000 kPa	5075 psi	35 000 kPa	5075 psi	35 000 kPa	5075 psi
Travel Circuits	35 000 kPa	5075 psi	35 000 kPa	5075 psi	35 000 kPa	5075 psi
Swing Circuits	27 500 kPa	3988 psi	27 500 kPa	3988 psi	27 500 kPa	3988 psi
Pilot Circuits	4120 kPa	597 psi	4120 kPa	597 psi	4120 kPa	597 psi
Drive:						
Maximum Drawbar Pull	317 kN	71,264 lb	317 kN	71,264 lb	317 kN	71,264 lb
Maximum Travel Speed	4.8 km/h	3 mph	4.8 km/h	3 mph	4.8 km/h	3 mph
Log Loader Linkage:						
Boom Cylinder — Bore	150 mm	5.9"	150 mm	5.9"	150 mm	5.9"
Boom Cylinder — Stroke	1400 mm	55.1"	1400 mm	55.1"	1400 mm	55.1"
Stick Cylinder — Bore	180 mm	7.1"	180 mm	7.1"	180 mm	7.1"
Stick Cylinder — Stroke	1650 mm	65"	1650 mm	65"	1650 mm	65"
Under/Under Heel Cylinder — Bore	—		150 mm	5.9"	—	
Under/Under Heel Cylinder — Stroke	—		1155 mm	45.5"	—	
Over/Under Heel Cylinder — Bore	—		—		160 mm	6.3"
Over/Under Heel Cylinder — Stroke	—		—		1465 mm	57.7"
Track:						
Standard (HD double grouser)	700 mm	28"	700 mm	28"	700 mm	28"
Optional (HD triple grouser)	850 mm	34"	850 mm	34"	850 mm	34"
Overall Track Length	5060 mm	16'7"	5060 mm	16'7"	5060 mm	16'7"
Ground Clearance	760 mm	2'6"	760 mm	2'6"	760 mm	2'6"
Track Gauge	2920 mm	9'7"	2920 mm	9'7"	2920 mm	9'7"
Capacity:						
Fuel Tank (standard)	520 L	137.4 U.S. gal	520 L	137.4 U.S. gal	520 L	137.4 U.S. gal
Fuel Tank — Optional Auxiliary Right Front	410 L	108.3 U.S. gal	410 L	108.3 U.S. gal	410 L	108.3 U.S. gal
Cooling System	30 L	7.9 U.S. gal	30 L	7.9 U.S. gal	30 L	7.9 U.S. gal
Engine Oil	34 L	9.0 U.S. gal	34 L	9.0 U.S. gal	34 L	9.0 U.S. gal
Swing Drive	10 L	2.6 U.S. gal	10 L	2.6 U.S. gal	10 L	2.6 U.S. gal
Hydraulic System — Total	260 L	68.7 U.S. gal	260 L	68.7 U.S. gal	260 L	68.7 U.S. gal
Hydraulic System — Tank	145 L	38.3 U.S. gal	145 L	38.3 U.S. gal	145 L	38.3 U.S. gal
Final Drive (each)	8 L	2.1 U.S. gal	8 L	2.1 U.S. gal	8 L	2.1 U.S. gal

MODEL	568 FM General Forestry (HW)		568 FM Log Loader (U/U)		568 FM Log Loader (O/U)	
	221 kW	296 hp	221 kW	296 hp	221 kW	296 hp
Net Flywheel Power (SAE J1349)	221 kW	296 hp	221 kW	296 hp	221 kW	296 hp
Operating Weight (with front linkage, without bucket or grapple)	43 462 kg	95,616 lb	48 694 kg	107,128 lb	48 853 kg	107,478 lb
Swing Mechanism:						
Torque	113.9 kN·m	84,024 lb-ft	148.5 kN·m	109,560 lb-ft	148.5 kN·m	109,560 lb-ft
Speed	10 RPM		6.3 RPM		6.3 RPM	
Engine Model	C9.3 ACERT		C9.3 ACERT		C9.3 ACERT	
Emission Standards	Tier 4 Interim/Stage IIIB/ Japan 2011 (Tier 4 Interim) equivalent		Tier 4 Interim/Stage IIIB/ Japan 2011 (Tier 4 Interim) equivalent		Tier 4 Interim/Stage IIIB/ Japan 2011 (Tier 4 Interim) equivalent	
No. of Cylinders	6		6		6	
Bore	115 mm	4.53 in	115 mm	4.53 in	115 mm	4.53 in
Stroke	149 mm	5.87 in	149 mm	5.87 in	149 mm	5.87 in
Displacement	9.3 L	567.5 in ³	9.3 L	567.5 in ³	9.3 L	567.5 in ³
Hydraulic System:						
Main Implement System — Maximum Flow (2X)	26 L/min	6.87 gpm	26 L/min	6.87 gpm	26 L/min	6.87 gpm
Relief Valve Settings:						
Implement Circuits	35 000 kPa	5076 psi	35 000 kPa	5076 psi	35 000 kPa	5076 psi
Maximum Pressure — Swing (single)	28 000 kPa	4061 psi	28 000 kPa	4061 psi	28 000 kPa	4061 psi
Maximum Pressure — Swing (dual)	31 400 kPa	4550 psi	31 400 kPa	4550 psi	31 400 kPa	4550 psi
Drive:						
Maximum Drawbar Pull	317 kN	71,264 lb-ft	317 kN	71,264 lb-ft	317 kN	71,264 lb-ft
Maximum Travel Speed	4.8 km/h	3 mph	4.8 km/h	3 mph	4.8 km/h	3 mph
Log Loader Linkage:						
Boom Cylinder — Bore	170 mm	6.7 in	170 mm	6.7 in	170 mm	6.7 in
Boom Cylinder — Stroke	1340 mm	52.8 in	1340 mm	52.8 in	1340 mm	52.8 in
Stick Cylinder — Bore	180 mm	7.1 in	180 mm	7.1 in	180 mm	7.1 in
Stick Cylinder — Stroke	1661 mm	65.4 in	1661 mm	65.4 in	1661 mm	65.4 in
Under/Under Heel Cylinder — Bore	150 mm	5.9 in	150 mm	5.9 in	150 mm	5.9 in
Under/Under Heel Cylinder — Stroke	1155 mm	45.5 in	1155 mm	45.5 in	1155 mm	45.5 in
Over/Under Heel Cylinder — Bore	160 mm	6.3 in	160 mm	6.3 in	160 mm	6.3 in
Over/Under Heel Cylinder — Stroke	1465 mm	57.7 in	1465 mm	57.7 in	1465 mm	57.7 in
Track:						
Standard (HD double grouser)	700 mm	28 in	700 mm	28 in	700 mm	28 in
Optional (HD triple grouser)	850 mm	34 in	850 mm	34 in	850 mm	34 in
Overall Track Length	5390 mm	212 in	5390 mm	212 in	5390 mm	212 in
Ground Clearance	760 mm	30 in	760 mm	30 in	760 mm	30 in
Track Gauge	2920 mm	115 in	2920 mm	115 in	2920 mm	115 in
Capacity:						
Fuel Tank (standard)	1200 L	317 U.S. gal	1200 L	317 U.S. gal	1200 L	317 U.S. gal
Cooling System	56 L	14.8 U.S. gal	56 L	14.8 U.S. gal	56 L	14.8 U.S. gal
Engine Oil	30.5 L	8.1 U.S. gal	30.5 L	8.1 U.S. gal	30.5 L	8.1 U.S. gal
Swing Drive (each)	19 L	5 U.S. gal	20 L	5.3 U.S. gal	20 L	5.3 U.S. gal
Hydraulic System — Total	380 L	100.4 U.S. gal	380 L	100.4 U.S. gal	380 L	100.4 U.S. gal
Hydraulic System — Tank	175 L	46.2 U.S. gal	175 L	46.2 U.S. gal	175 L	46.2 U.S. gal
Final Drive (each)	8 L	2.1 U.S. gal	8 L	2.1 U.S. gal	8 L	2.1 U.S. gal

General Forestry
HD/LC 5.9 m (19'4") Boom
with R2.9B1 (9'6") Stick

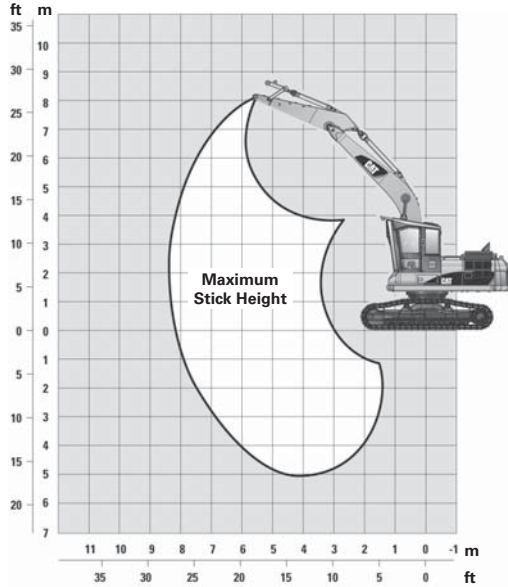

General Forestry
HW 5.9 m (19'4") Boom
with R2.9B1 (9'6") Stick

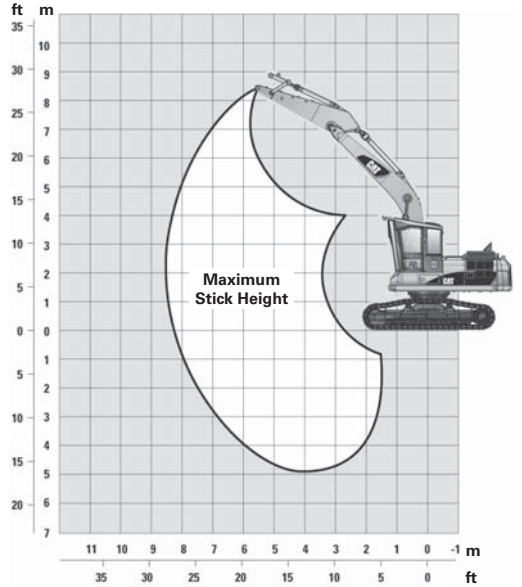

**Heel Boom
(Under/Under)**

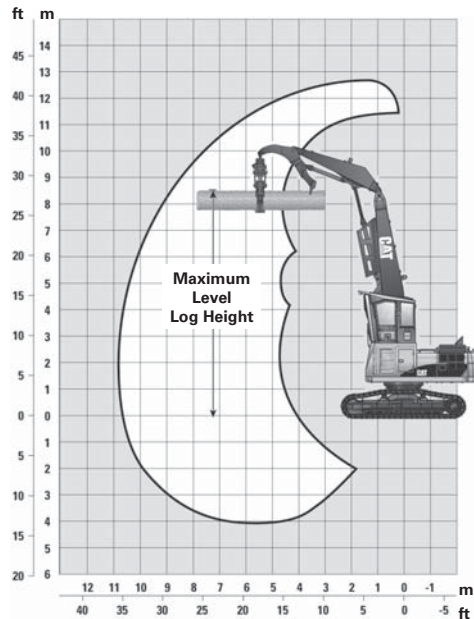

**Heel Boom
Under/Under**

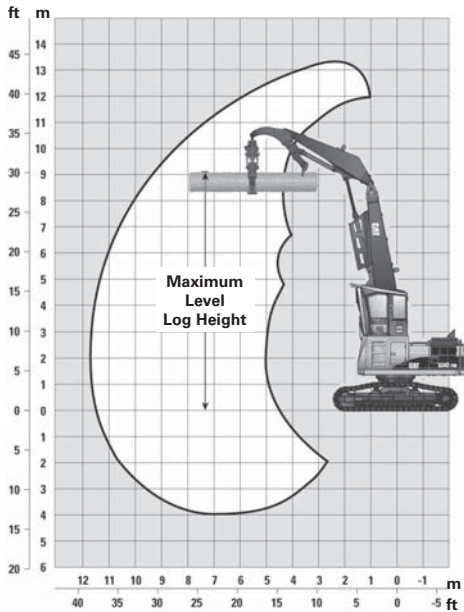

**Heel Boom
Over/Under**

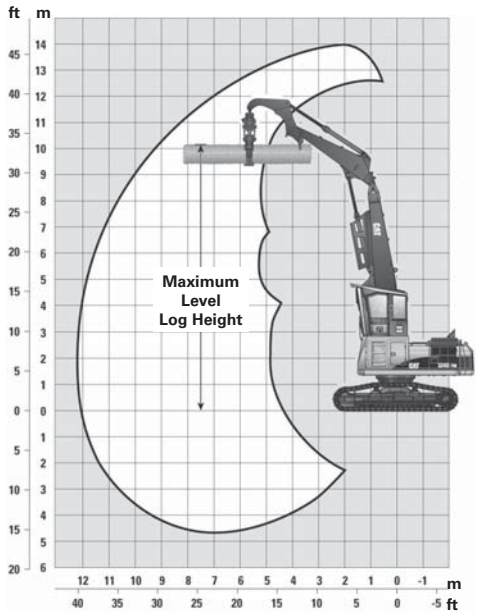

5

**General Forestry
HW U/C, 5.9 m (19'4") Boom
with 2.95S Stick**

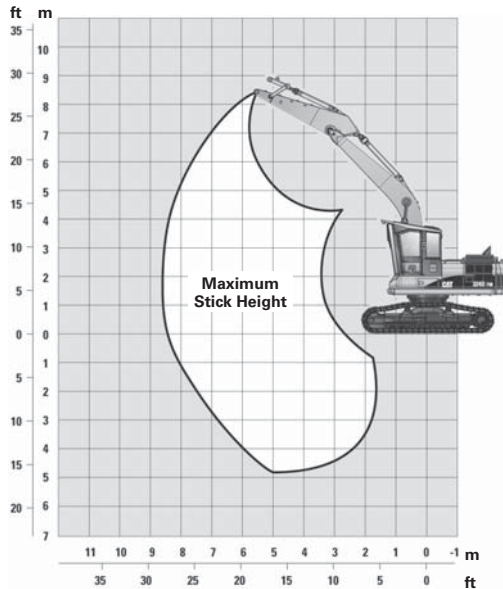

**Heel Boom
Under/Under**

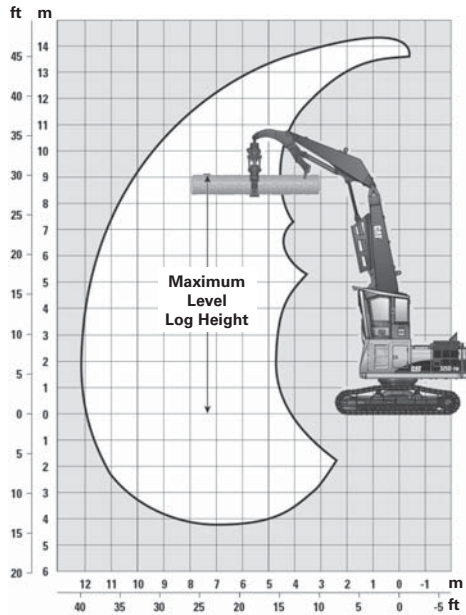

**Heel Boom
Over/Under**

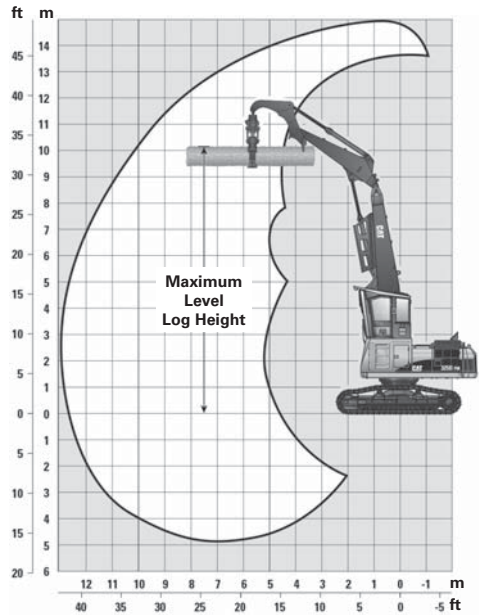

**Log Loader
(Butt-n-Top)**

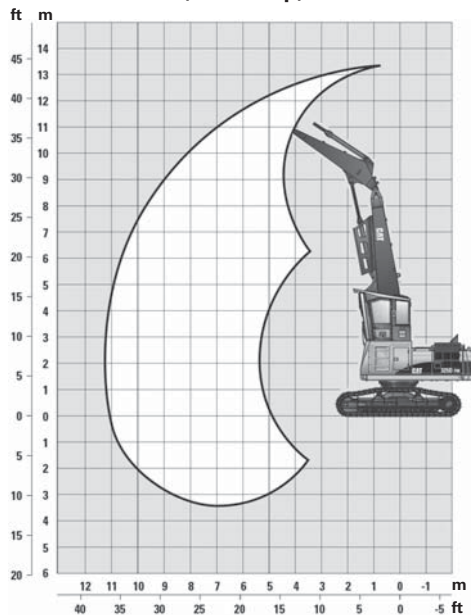

General Forestry
Mass Boom 5.5 m (18'2")
Stick 3.2 m (10'2")

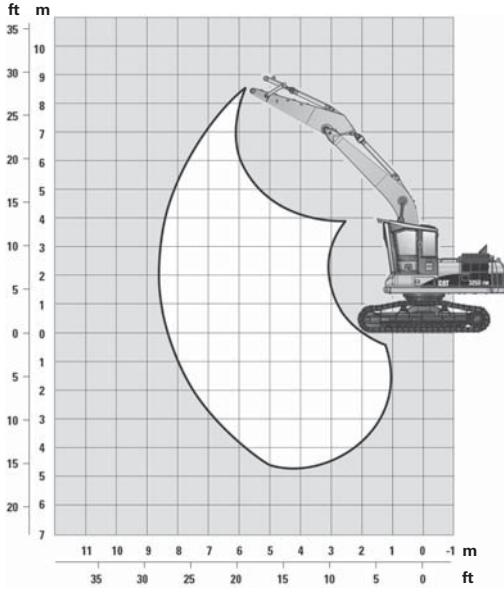

General Forestry
Reach Boom 6.2 m (20'2")
Stick 3.2 m (10'2")

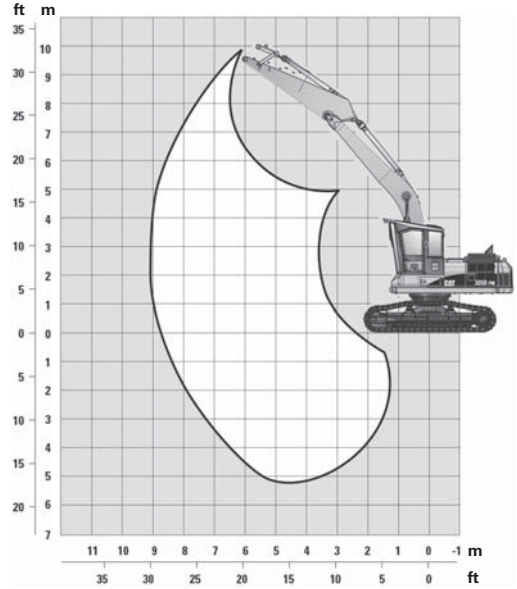

**Heel Boom
Under/Under**

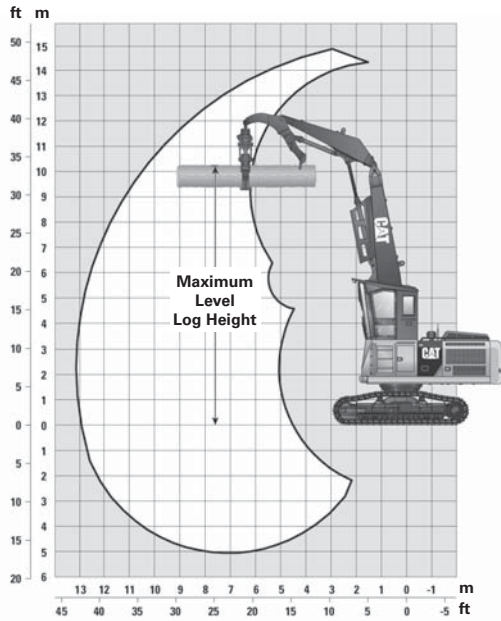

**Heel Boom
Over/Under**

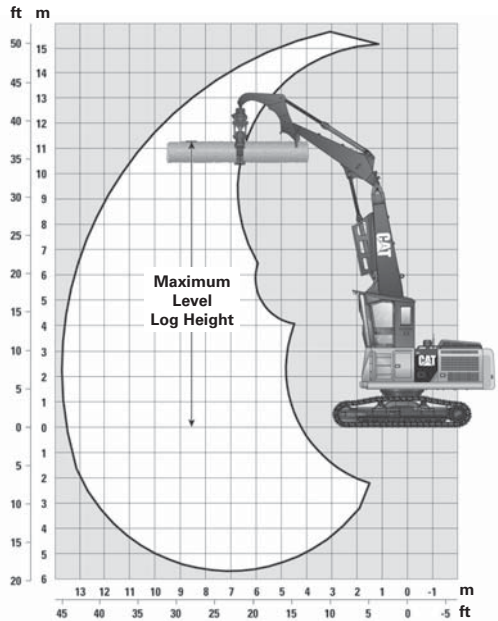

**General Forestry
3.9 m (12'10") Reach Boom**

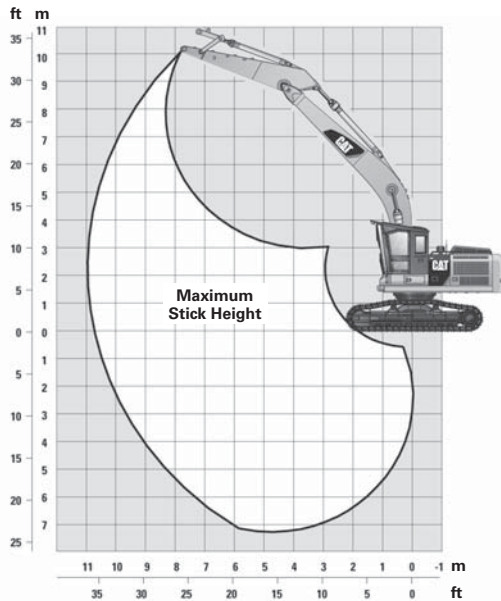

**General Forestry
3.5 m (11'6") Reach Boom**

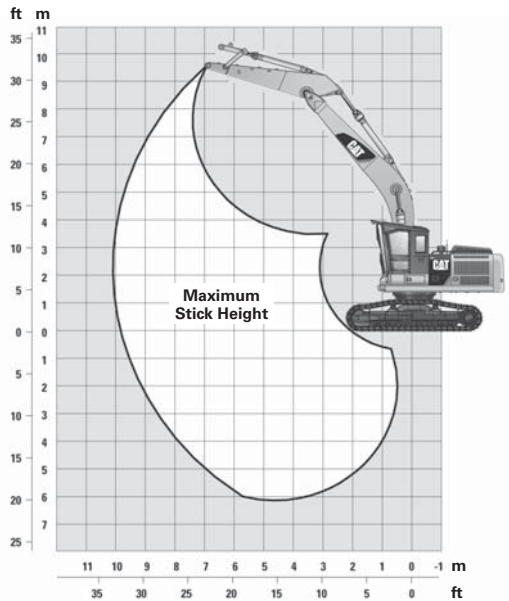

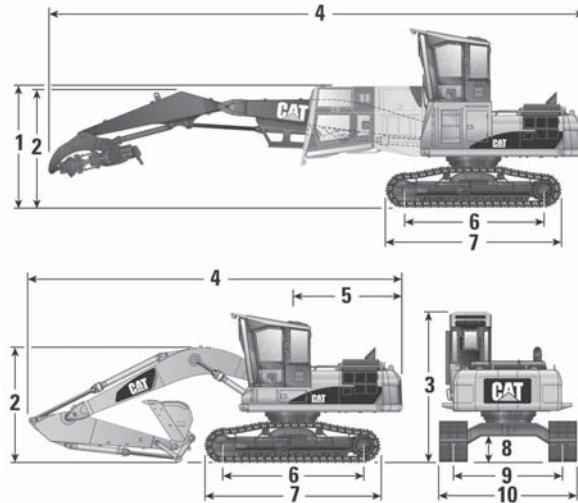

320D FM General Forestry

	HW		HD/LC	
1 Shipping height (All risers with cab tilted)	3185 mm	10'5"	3000 mm	9'10"
2 Boom height	3060 mm	10'0"	3040 mm	10'0"
3 Overall height	3898 mm	12'10"	3713 mm	12'2"
4 Shipping length	9410 mm	30'10"	9460 mm	31'0"
5 Tail swing radius	2774 mm	9'1"	2774 mm	9'1"
6 Track length – idler to sprocket	3715 mm	12'2"	3650 mm	12'0"
7 Track length – total	4555 mm	14'11"	4480 mm	14'8"
8 Ground clearance	650 mm	2'2"	475 mm	1'7"
9 Track gauge	2590 mm	8'6"	2380 mm	7'10"
10 Transport width with 700 mm (27.5") shoes (DG)	3290 mm	10'10"	3080 mm	10'1"

320D FM Log Loaders

	Under/Under	
1 Shipping height (All risers with cab tilted)	3185 mm	10'5"
2 Boom height	2980 mm	9'9"
3 Overall height	4657 mm	15'3"
4 Shipping length	13 620 mm	44'8"
5 Tail swing radius	2774 mm	9'1"
6 Track length – idler to sprocket	3715 mm	12'2"
7 Track length – total	4555 mm	14'11"
8 Ground clearance	650 mm	2'2"
9 Track gauge	2590 mm	8'6"
10 Transport width with 700 mm (27.5") shoes (DG)	3290 mm	10'10"

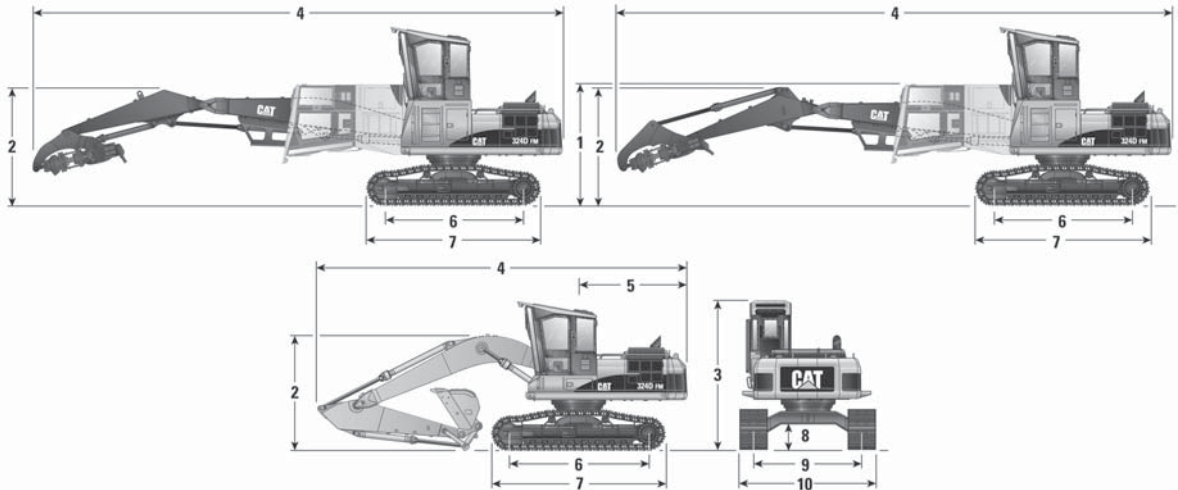

324D FM General Forestry

HW GF

1 Shipping height (All risers with cab tilted)	3310 mm	10'10"
2 Boom height	3170 mm	10'5"
3 Overall height	4020 mm	13'2"
4 Shipping length	9880 mm	32'5"
5 Tail swing radius	2940 mm	9'8"
6 Track length – idler to sprocket	4052 mm	13'4"
7 Track length – total	4967 mm	16'4"
8 Ground clearance	743 mm	2'5"
9 Track gauge	2920 mm	9'7"
10 Transport width with 700 mm (27.5") shoes (DG)	3620 mm	11'11"

324D FM Log Loaders

Under/Under

Over/Under

1 Shipping height (All risers with cab tilted)	3310 mm	10'10"	3310 mm	10'10"
2 Boom height	2780 mm	9'1"	2760 mm	9'1"
3 Overall height	4790 mm	15'9"	4790 mm	15'9"
4 Shipping length	14 080 mm	46'2"	14 990 mm	49'2"
5 Tail swing radius	2940 mm	9'8"	2940 mm	9'8"
6 Track length – idler to sprocket	4052 mm	13'4"	4052 mm	13'4"
7 Track length – total	4967 mm	16'4"	4967 mm	16'4"
8 Ground clearance	743 mm	2'5"	743 mm	2'5"
9 Track gauge	2920 mm	9'7"	2920 mm	9'7"
10 Transport width to steps with 700 mm (27.5") shoes (DG)	3620 mm	11'11"	3620 mm	11'11"

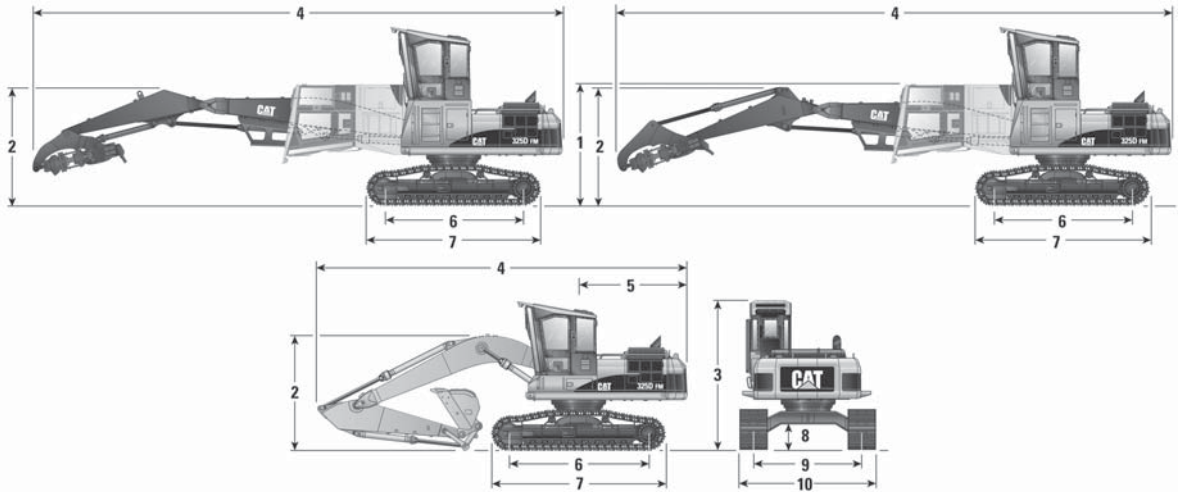

325D FM General Forestry

HW GF

1 Shipping height (All risers with cab tilted)	3535 mm	11'7"
2 Boom height	3310 mm	10'10"
3 Overall height	4155 mm	13'8"
4 Shipping length	10 260 mm	33'8"
5 Tail swing radius	3020 mm	9'11"
6 Track length – idler to sprocket	4020 mm	13'2"
7 Track length – total	5060 mm	16'7"
8 Ground clearance	767 mm	2'6"
9 Track gauge	2920 mm	9'7"
10 Transport width with 700 mm (27.5") shoes (DG)	3650 mm to steps	12'0" to steps

325D FM Log Loaders

Under/Under

Over/Under

1 Shipping height (All risers with cab tilted)	3535 mm	11'7"	3535 mm	11'7"
2 Boom height	2760 mm	9'1"	2740 mm	9'0"
3 Overall height	4910 mm	16'1"	4910 mm	16'1"
4 Shipping length	15 290 mm	50'2"	14 640 mm	48'0"
5 Tail swing radius	3020 mm	9'11"	3020 mm	9'11"
6 Track length – idler to sprocket	4020 mm	13'2"	4020 mm	13'2"
7 Track length – total	5060 mm	16'7"	5060 mm	16'7"
8 Ground clearance	767 mm	2'6"	767 mm	2'6"
9 Track gauge	2920 mm	9'7"	2920 mm	9'7"
10 Transport width with 700 mm (27.5") shoes (DG)	3650 mm to steps	12'0" to steps	3650 mm to steps	12'0" to steps

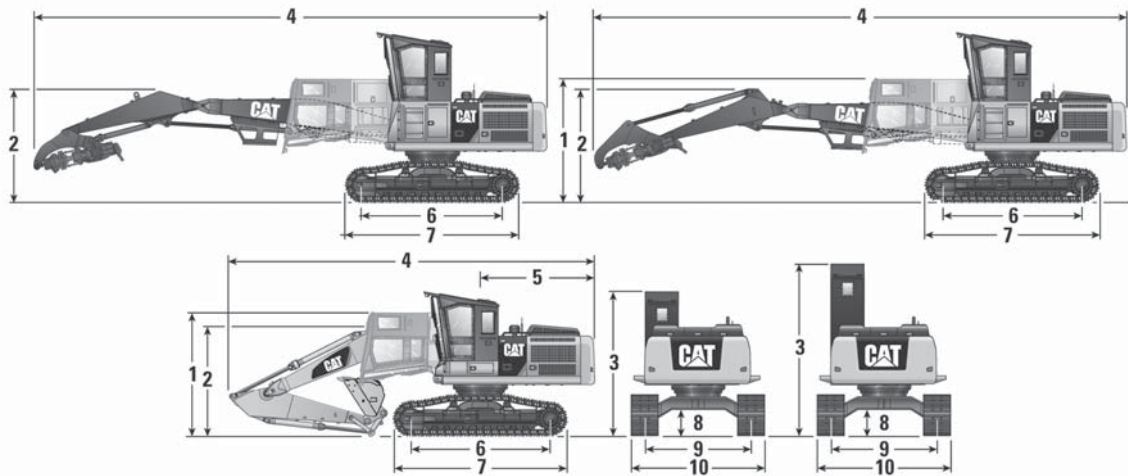

568 FM General Forestry

HW GF

1 Shipping height (All risers with cab tilted)	3520 mm	11'7"
2 Boom height	3520 mm	11'7"
3 Overall height	4190 mm	13'9"
4 Shipping length	10 780 mm	35'5"
5 Tail swing radius	3460 mm	11'4"
6 Track length – idler to sprocket	4356 mm	14'3"
7 Track length – total	5390 mm	17'7"
8 Ground clearance	760 mm	2'6"
9 Track gauge	2920 mm	9'7"
10 Transport width with 700 mm (27.5") shoes (DG)	3650 mm to steps	12'0" to steps

568 FM Log Loaders

Under/Under

Over/Under

1 Shipping height (All risers with cab tilted)	3520 mm	11'6"	3520 mm	11'6"
2 Boom height	3074 mm	10'1"	3074 mm	10'1"
3 Overall height	4954 mm	16'3"	4954 mm	16'3"
4 Shipping length	16 610 mm	54'5"	17 080 mm	56'0"
5 Tail swing radius	3460 mm	11'4"	3460 mm	11'4"
6 Track length – idler to sprocket	4356 mm	14'3"	4356 mm	14'3"
7 Track length – total	5390 mm	17'7"	5390 mm	17'7"
8 Ground clearance	760 mm	2'6"	760 mm	2'6"
9 Track gauge	2920 mm	9'7"	2920 mm	9'7"
10 Transport width with 700 mm (27.5") shoes (DG)	3650 mm to steps	12'0" to steps	3650 mm to steps	12'0" to steps

529/559C/579C Features:

- **Advanced boom design technology** built tough with welded high-strength steel.
- **Booms** are engineered to withstand high production pull-through delimiting and loading.
- **Boom reach** ranges from 8.8 m (29 ft) on the 529 up to 10.9 m (36 ft) on the 579C.
- **Smooth and responsive joystick controls.**
- **Swing torque ratings** up to nearly 100 kN·m (73,700 lb-ft), combined with swing speeds up to 11 RPM.
- **Continuous rotation grapples** are constructed of wear resistant, high tensile steel with heavy-duty rotators designed for strenuous pull-through delimiting applications.

- **Heavy-duty sub-frames** are engineered for high reliability and stability.
- **Heavy duty off road axles** provide trouble free operation in the harsh woods environment.
- **Quiet, comfortable cabs** with excellent visibility.

Loaders offered with a factory matched performance package — The “DS” package is a complete factory installed timber merchandising system consisting of a knuckleboom loader and grapple, trailer with trailer mounted delimeter.

MODEL	529		559C		579C	
Gross Power	116.3 kW	156 hp	129.3 kW	173 hp	129.3 kW	173 hp
Engine	C6.6 ACERT		C6.6 ACERT		C6.6 ACERT	
Engine RPM	2200		1800		1800	
Operating Weight (with standard boom, less options, carrier & grapple)	12 655 kg	27,900 lb	15 558 kg	34,300 lb	16 674 kg	36,760 lb
Hydraulic System:						
System Pressure	18 960 kPa	2750 psi	24 131 kPa	3500 psi	24 131 kPa	3500 psi
Swing Pressure	18 271 kPa	2650 psi	24 131 kPa	3500 psi	24 131 kPa	3500 psi
Swing Speed	8 RPM		11 RPM		9 RPM	
Capacities:						
Fuel Capacity	276.3 L	73 U.S. gal	378.5 L	100 U.S. gal	378.5 L	100 U.S. gal
Hydraulic Capacity	295.3 L	78 U.S. gal	302.8 L	80 U.S. gal	302.9 L	80 U.S. gal
Counterweight	1496.8 kg	3300 lb	0 kg	0 lb	653.2 kg	1440 lb
Tailswing (with counterweight)	248.9 cm	98"	297.7 cm	117.2"	299.5 cm	117.9"
Knuckleboom Length	8.8 m	29'0"	9.75 m	32'0"	9.75 m	32'0"

Processing/Loading Trailer Mount Knuckleboom Loaders

Dimensions

Basic Dimensions for 529, 559C and 579C

(Loader trailer shown for dimensional reference only. Trailer is not included with loader.)

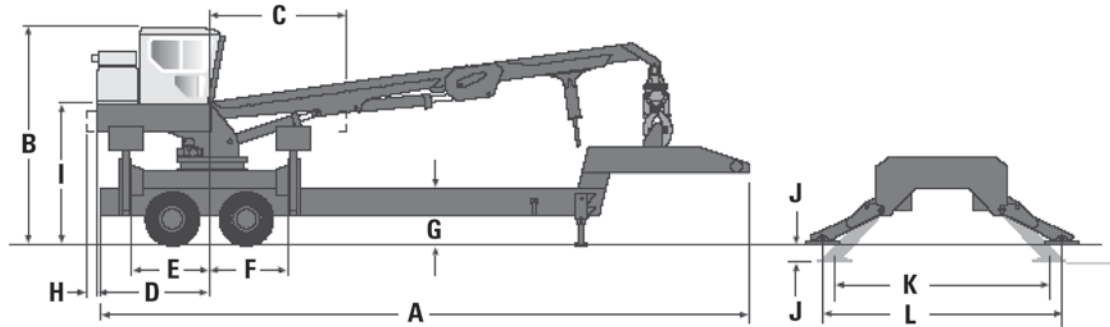

MODEL	529		559C		579C	
A	1219.2 cm	480.00"	1526.2 cm	600.9"	1526.2 cm	600.9"
B	404.5 cm	159.25"	400.2 cm	157.6"	400.2 cm	157.6"
C*	248.9 cm	98.00"	297.6 cm	117.2"	299.4 cm	117.9"
D	232.0 cm	91.34"	269.2 cm	106.0"	269.2 cm	106.0"
E	152.4 cm	60.00"	166.9 cm	65.7"	166.9 cm	65.7"
F	152.4 cm	60.00"	166.9 cm	65.7"	166.9 cm	65.7"
G	99.1 cm	39.00"	99.1 cm	39.0"	99.1 cm	39.0"
H**	24.1 cm	9.50"	0 cm	0"	5.7 cm	2.3"
I	246.4 cm	97.00"	246.8 cm	97.2"	246.8 cm	97.2"
J	36.0 cm	14.18"	43.3 cm	17.0"	43.3 cm	17.0"
K	392.0 cm	154.35"	423.7 cm	166.8"	423.7 cm	166.8"
L	447.0 cm	176.00"	475.3 cm	187.3"	475.8 cm	187.3"

*Maximum tailswing.
**Add for counterweight.

Lift and Range Diagram

● 529 Knuckleboom Loader

Processing/Loading Trailer Mount Knuckleboom Loaders

529 Knuckleboom Loader 8.8 m (29'0") Boom

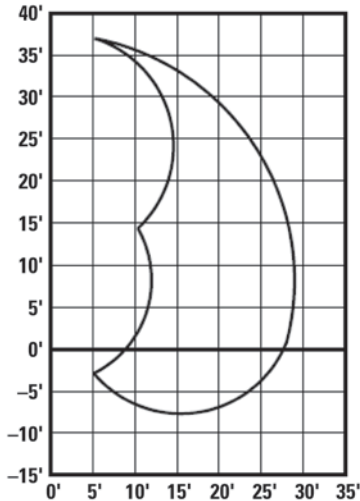

NOTES:

Do not attempt to lift or hold any load that is greater than the rated values over the end or side. The weight of the grapple and all lifting accessories must be deducted from lift capacities shown.

1. The over end capacities and over side capacities do not exceed 87% of hydraulic limited capacity or 75% of stability limited capacity.
– Stability limited capacities are indicated with an asterisk (*).
2. The lift point is located at the grapple knuckle pin.
3. Lift capacities are based on the machine standing on firm, uniform supporting surface. User must make allowances for job site conditions.
4. Operator should be fully acquainted with the Operator's Manual and all safety instructions furnished by Caterpillar Inc. prior to operating the machine.
5. Lift capacities are in compliance with SAE J2417, "Lift Capacity Calculation Method – Knuckleboom Log Loaders and Certain Forestry Equipment."

	3 m/10'0"		4.6 m/15'0"		6.1 m/20'0"		7.6 m/25'0"		Maximum Reach		
	kg	lb	kg	lb	kg	lb	kg	lb	kg	lb	
9.1 m (30'0")			5591.9 4864.8 4864.8	12,328 10,725 10,725							100% Hydraulics Over End Over Side
7.6 m (25'0")			5854.1 5093.1 5093.1	12,906 11,228 11,228	5136.6 4468.8 4468.8	11,324 9,852 9,852					100% Hydraulics Over End Over Side
6.1 m (20'0")			5896.7 5130.2 5130.2	13,000 11,310 11,310	5481.7 4769.2 4769.2	12,085 10,514 10,514	4159.5 3618.8 3618.8	9,170 7,978 7,978			100% Hydraulics Over End Over Side
4.6 m (15'0")			6384.8 5554.7 5554.7	14,076 12,246 12,246	5641.8 4908.4 4908.4	12,438 10,821 10,821	4650.8 4046.1 4046.1	10,253 8,920 8,920	2379.5 2070.2 2070.2	5,246 4,564 4,564	100% Hydraulics Over End Over Side
3.0 m (10'0")			7557.4 6574.8 6574.8	16,661 14,495 14,495	6542.2 5691.7 5691.7	14,423 12,548 12,548	5072.6 4413.1 4413.1	11,183 9,729 9,729	2344.2 2039.4 2039.4	5,168 4,496 4,496	100% Hydraulics Over End Over Side
1.5 m (5'0")			8857.8 7706.2 7706.2	19,528 16,989 16,989	6573.1 5718.5 5718.5	14,491 12,607 12,607	4963.7 4318.2 4318.2	10,943 9,520 9,520	2355.9 2049.8 2049.8	5,194 4,519 4,519	100% Hydraulics Over End Over Side
0 m (0'0")	6924.5 6024.2 6024.2	15,266 13,281 13,281	8425.6 7330.2 7330.2	18,575 16,160 16,160	6101.3 5308.1 5308.1	13,451 11,702 11,702	4259.8 3705.9 3705.9	9,391 8,170 8,170			100% Hydraulics Over End Over Side
-1.5 m (-5'0")	7980.1 6942.8 6942.8	17,593 15,306 15,306	6807.2 5922.2 5922.2	15,007 13,056 13,056	4782.3 4160.4 4160.4	10,543 9,172 9,172					100% Hydraulics Over End Over Side

Processing/Loading Trailer Mount Knuckleboom Loaders

Lift and Range Diagram ● 559C Knuckleboom Loader

559C Knuckleboom Loader 9.8 m (32'0") Boom

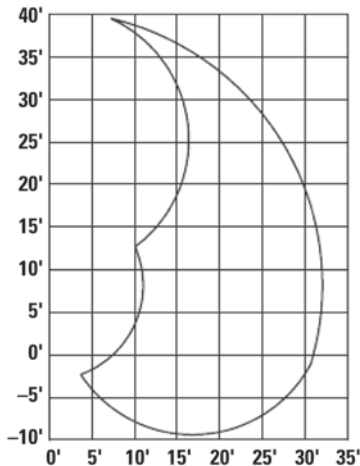

NOTES:

Do not attempt to lift or hold any load that is greater than the rated values over the end or side. The weight of the grapple and all lifting accessories must be deducted from lift capacities shown.

1. The over end capacities and over side capacities do not exceed 87% of hydraulic limited capacity or 75% of stability limited capacity.
– Stability limited capacities are indicated with an asterisk (*).
2. The lift point is located at the grapple knuckle pin.
3. Lift capacities are based on the machine standing on firm, uniform supporting surface. User must make allowances for job site conditions.
4. Operator should be fully acquainted with the Operator's Manual and all safety instructions furnished by Caterpillar Inc. prior to operating the machine.
5. Lift capacities are in compliance with SAE J2417, "Lift Capacity Calculation Method – Knuckleboom Log Loaders and Certain Forestry Equipment."

	3 m/10'0"		4.6 m/15'0"		6.1 m/20'0"		7.6 m/25'0"		9.1 m/30'0"		Maximum Reach		
	kg	lb	kg	lb	kg	lb	kg	lb	kg	lb	kg	lb	
10.6 m (35'0")			6253.7 5441.0 5441.0	13,805.0 12,011.0									100% Hydraulics Over End Over Side
9.1 m (30'0")					5898.5 5131.6 5131.6	13,021 11,328 11,328							100% Hydraulics Over End Over Side
7.6 m (25'0")					6089.7 5298.3 5298.3	13,443 11,696 11,696	5588.7 4569.0 4569.0	12,337 10,086 10,086					100% Hydraulics Over End Over Side
6.1 m (20'0")					6235.5 5425.1 5425.1	13,765 11,976 11,976	5751.3 4862.0 4862.0	12,696 10,733 10,733					100% Hydraulics Over End Over Side
4.6 m (15'0")			7849.6 6829.0 6829.0	17,328 15,075 15,075	6658.6 5793.0 5793.0	14,699 12,788 12,788	6541.8 5003.8 5003.8	14,441 11,046 11,046	4809.0 4183.9 3665.6*	10,616 9236 8092*			100% Hydraulics Over End Over Side
3.0 m (10'0")			9117.5 7932.0 7932.0	20,127 17,510 17,510	7891.7 6865.7 6865.7	17,421 15,156 15,156	6660.0 5691.0 5017.9*	14,702 12,563 11,077*	4922.8 4282.7 3606.8*	10,867 9454 7962*	3578.7 3113.5 3113.5	7900 6873 6873	100% Hydraulics Over End Over Side
1.5 m (5'0")			11152.4 9702.8 9702.8	24,619 21,419 21,419	8385.0 7295.1 7235.3*	18,510 16,104 15,972*	6660.0 5794.3 4852.5	14,702 12,791 10,712*	4749.3 4131.8 3538.4	10,484 9121 7811*			100% Hydraulics Over End Over Side
0 m (0'0")	9419.2 8194.8 8194.8	20,793 18,090 18,090	11478.1 9985.9 9985.9	25,338 22,044 22,044	8419.9 7325.5 6951.3	18,587 16,171 15,345*	6439.4 5602.3 4719.4	14,215 12,367 10,418*	4231.9 3681.5 3494.9	9342 8127 7715*			100% Hydraulics Over End Over Side
-1.5 m (-5'0")	8938.1 7776.2 7776.2	19,731 17,166 17,166	10516.8 9149.7 9149.7	23,216 20,198 20,198	7672.5 6675.0 6511.9*	16,937 14,735 14,375*	5566.0 4842.6 4657.3*	12,287 10,690 10,281*					100% Hydraulics Over End Over Side

Lift and Range Diagram ● 579C Knuckleboom Loader

Processing/Loading Trailer Mount Knuckleboom Loaders

579C Knuckleboom Loader 9.9 m (32'6") Boom

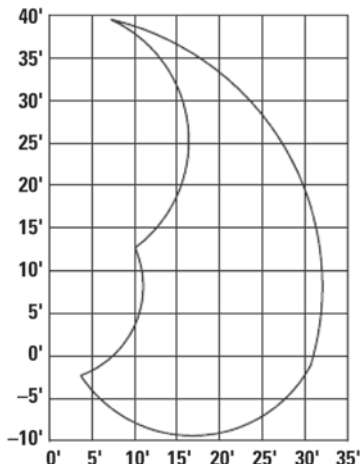

NOTES:

Do not attempt to lift or hold any load that is greater than the rated values over the end or side. The weight of the grapple and all lifting accessories must be deducted from lift capacities shown.

1. The over end capacities and over side capacities do not exceed 87% of hydraulic limited capacity or 75% of stability limited capacity.
– Stability limited capacities are indicated with an asterisk (*).
2. The lift point is located at the grapple knuckle pin.
3. Lift capacities are based on the machine standing on firm, uniform supporting surface. User must make allowances for job site conditions.
4. Operator should be fully acquainted with the Operator's Manual and all safety instructions furnished by Caterpillar Inc. prior to operating the machine.
5. Lift capacities are in compliance with SAE J2417, "Lift Capacity Calculation Method – Knuckleboom Log Loaders and Certain Forestry Equipment."

	3 m/10'0"		4.6 m/15'0"		6.1 m/20'0"		7.6 m/25'0"		9.1 m/30'0"		Maximum Reach		
	kg	lb	kg	lb	kg	lb	kg	lb	kg	lb	kg	lb	
10.6 m (35'0")			7455.0 6485.6 6485.6	16,457.0 14,317.0 14,317.0									100% Hydraulics Over End Over Side
9.1 m (30'0")					7039.2 6124.1 6124.1	15,539 13,519 13,519							100% Hydraulics Over End Over Side
7.6 m (25'0")					7233.5 6293.1 6293.1	15,968 13,892 13,892	6280.8 5464.5 5464.5	13,865 12,063 12,063					100% Hydraulics Over End Over Side
6.1 m (20'0")					7412.0 6448.5 6448.5	16,362 14,235 14,235	6695.8 5845.5 5845.5	14,781 12,860 12,860					100% Hydraulics Over End Over Side
4.6 m (15'0")			9268.8 8063.9 8063.9	20,461 17,801 17,801	7929.3 6898.7 6898.7	17,504 15,229 15,229	6898.3 6001.3 5748.2*	15,228 13,248 12,646*	5761.7 5012.9 4108.6*	12,719 11,066 9039*			100% Hydraulics Over End Over Side
3.0 m (10'0")			10 887.4 9471.8 9471.8	24,034 20,909 20,909	9338.1 8124.1 8124.1	20,614 17,934 17,934	7782.5 6771.0 5592.3*	17,180 14,947 12,303*	5958.8 5184.1 4049.1*	13,154 11,444 8908*	4318.0 3756.7 3609.1*	9532 8293 7940*	100% Hydraulics Over End Over Side
1.5 m (5'0")			13 174.1 11 461.4 11 461.4	29,082 25,301 25,301	9947.4 8654.6 8045.0*	21,959 19,105 17,699*	7940.6 6908.3 5424.1*	17,529 15,250 11,933*	5767.1 5017.4 3980*	12,731 11,076 8756*			100% Hydraulics Over End Over Side
0 m (0'0")	12 569.8 10 935.4 10 935.4	27,748 24,140 24,140	13 608.6 11 839.2 11 839.2	30,041 26,135 26,135	10 020.4 8717.5 7757.3*	22,120 19,244 17,066*	7702.8 6701.7 5289.5*	17,004 14,794 11,637*	5118.9 4453.4 3935.5*	11,300 9831 8658*			100% Hydraulics Over End Over Side
-1.5 m (-5'0")	11 940.2 10 387.7 10 387.7	26,358 22,931 22,931	12 527.3 10 898.7 10 898.7	27,654 24,059 24,059	9174.6 7981.9 7601.4*	20,253 17,620 16,723*	6702.6 5831.5 5226.8*	14,796 12,873 11,499*					100% Hydraulics Over End Over Side

519/569 Features:

- **Heavy-duty boom options** range in length from 8.2 m (27 ft) to 10.90 m (36 ft) for handling a variety of tree lengths.
- **Weatherproof electric service panels** include starters, controls, transformers, circuit breakers and fuse blocks.
- **Electric motors** are rated for severe duty.
- **Resilient Pad Mounting System** includes a set of special rubber isolators on each mounting fastener that absorbs stress in two directions.
- **Hydraulic pilot joystick controls and rocker swing pedal** are ergonomically designed for ease of operation and maximum loader control.

MODEL	519 SM		519 SM/EHC		569 SM		569 SM/EHC	
Electric Power Supply (standard)	460 Volt: 60 Hz		460 Volt: 60 Hz		460 Volt: 60 Hz		460 Volt: 60 Hz	
Electric Power Supply (optional)*	575 Volt: 60 Hz		575 Volt: 60 Hz		575 Volt: 60 Hz		575 Volt: 60 Hz	
Electric Motor @ 1800 RPM	56 kW	75 hp	56 kW	75 hp	74 kW	100 hp	74 kW	100 hp
Operating Weight	7218.9 kg	15,915 lb	6946.7 kg	15,315 lb	8593.3 kg	18,945 lb	8321.1 kg	18,345 lb
Hydraulic System:								
System Pressure	15 168 kPa	2200 psi	15 168 kPa	2200 psi	17 237 kPa	2500 psi	17 237 kPa	2500 psi
Swing Pressure	16 547 kPa	2400 psi	16 547 kPa	2400 psi	17 237 kPa	2500 psi	17 237 kPa	2500 psi
Swing Speed	8 RPM		8 RPM		7 RPM		7 RPM	
Knuckleboom Length (standard)	8.2 m	27'0"	8.2 m	27'0"	9.9 m	32'6"	9.9 m	32'6"
Knuckleboom Length (optional)	9.1 m	30'0"	9.1 m	30'0"	11.0 m	36'0"	11.0 m	36'0"

*NOTE: Other Electric Power options available by special quote.

Electrical Code Requirements:

Cat Electric Stationary Mount Loaders are designed to meet National Electrical Code (NEC) requirements in the United States. However, the Dealer/Customer is responsible to investigate local Electrical Code requirements that may exist and make updates as required to the machine to meet additional local requirements.

Incoming Supply Power Requirements for the Stationary Mount Loaders:

Incoming supply power specification for all stationary mount loaders must be within $\pm 5\%$ of nominal for proper operation/reliability of the machine. A customer/dealer supplied transformer must be installed to accommodate the incoming power requirements if needed.

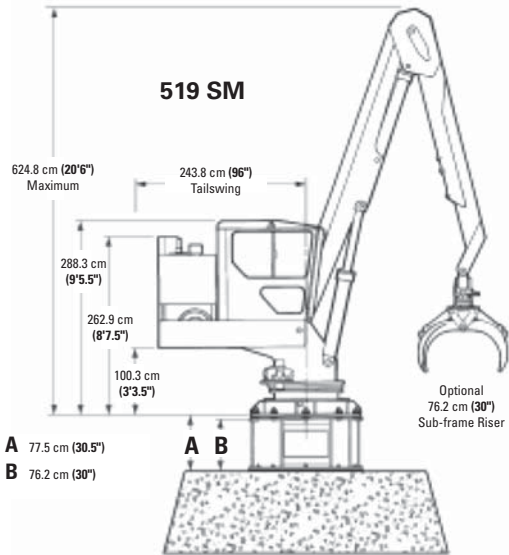

NOTE: Overall height dimension to 8.2 m (27'0") boom articulation point is taken with main boom cylinder fully extended. Add 76.2 cm (30") to this dimension for 9.1 m (30'0") knuckleboom.

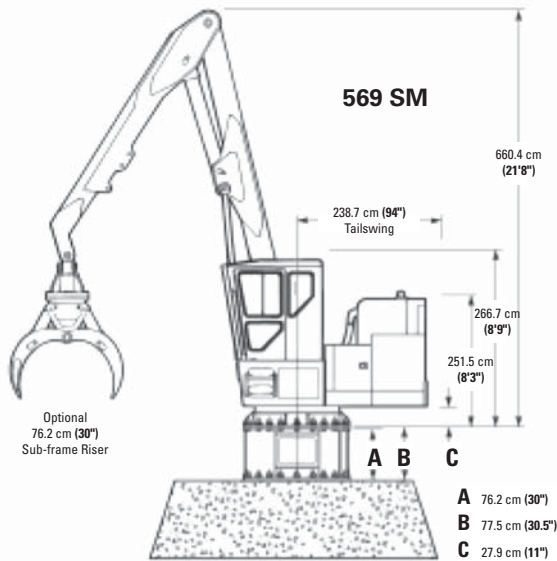

NOTE: Overall height dimension to 9.1 m (30'0") boom articulation point is taken with main boom cylinder fully extended. Add 106.9 cm (42") to this dimension for 10.9 m (36'0") knuckleboom.

Resilient Pad System

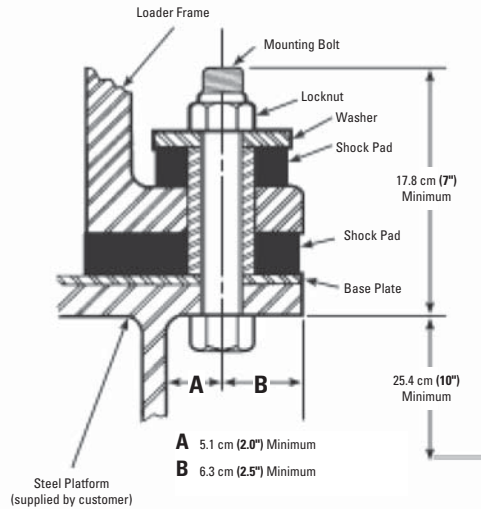

- Operator's cab is not present on EHC models.
- EHC models available with Remote Power Packs.
- Installations on concrete include "J" Bolts in lieu of Mounting Bolt.
- Continuous rotation units require 76.2 cm (30") minimum working clearance beneath subframe or collector ring and wiring maintenance.
- The customer is responsible for the design and engineering of all mounting systems and Caterpillar Forest Products recommends that the customer employs an engineer to perform this work.
- For additional installation guidelines refer to the Steel or Concrete information drawing for the stationary mount loader being installed. These information drawings along with engineering data to assist in the design of the support structure for the stationary mount loader are available from Caterpillar Forest Products upon request by the authorized dealer.

Millyards Stationary Mount Knuckleboom Loaders

Lift and Range Diagram

- 519 SM Knuckleboom Loader
- 519 SM/EHC Knuckleboom Loader

519 SM/519 SM/EHC 8.2 m (27'0") Boom

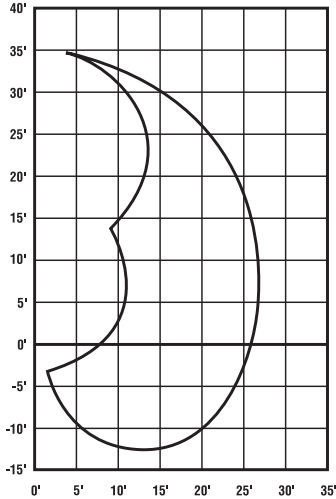

NOTES:

Do not attempt to lift or hold any load that is greater than the rated values over the end or side at their specified lift point and height. The weight of the grapple and all lifting accessories must be deducted from lift capacities shown.

1. All figures shown in these charts represent rated lift capacities.
2. Capacities shown in *italic* are 100% of hydraulic capacity; other capacities shown are 87% of hydraulic capability.
3. The lift point is located at the boom/grapple pivot pin.
4. Manufacturer assumes no responsibility for the proper fit or structural integrity of the mounting pedestal and/or platform supplied by the customer.
5. Operator should be fully acquainted with the Operator's Manual and all safety instructions furnished prior to operating the machine.
6. Lift capacities are in compliance with SAE J2417, "Lift Capacity Calculation Method – Knuckleboom Log Loaders and Certain Forestry Equipment."

	1.5 m/5'0"		3 m/10'0"		4.6 m/15'0"		6.1 m/20'0"		7.6 m/25'0"	
	kg	lb	kg	lb	kg	lb	kg	lb	kg	lb
7.6 m (25'0")					5021 4368	<i>11,060</i> <i>9,622</i>				
6.1 m (20'0")					5177 4504	<i>11,402</i> <i>9,920</i>	4486 3903	<i>9,882</i> <i>8,597</i>		
4.6 m (15'0")					5311 4620	<i>11,698</i> <i>10,177</i>	4634 4032	<i>10,207</i> <i>8,880</i>		
3.0 m (10'0")			3788 3295	<i>8,343</i> <i>7,258</i>	5854 5093	<i>12,894</i> <i>11,218</i>	4799 4175	<i>10,571</i> <i>9,197</i>	3962 3447	<i>8,728</i> <i>7,593</i>
1.5 m (5'0")					7229 6289	<i>15,923</i> <i>13,853</i>	5951 5177	<i>13,107</i> <i>11,403</i>	3890 3384	<i>8,568</i> <i>7,454</i>
0 m (0'0")					8730 6603	<i>19,229</i> <i>16,729</i>	6469 5628	<i>14,249</i> <i>12,397</i>	4061 3533	<i>8,946</i> <i>7,783</i>
-1.5 m (-5'0")			4764 4145	<i>10,494</i> <i>9,130</i>	8057 7010	<i>17,747</i> <i>15,440</i>	5811 5056	<i>12,800</i> <i>11,136</i>	3040 2645	<i>6,697</i> <i>5,826</i>
-3.0 m (-10'0")	3050 2654	<i>6,718</i> <i>5,845</i>	6276 5460	<i>13,824</i> <i>12,027</i>	6152 5353	<i>13,552</i> <i>11,790</i>	4083 3552	<i>8,993</i> <i>7,824</i>		
-4.6 m (-15'0")			3494 3040	<i>7,697</i> <i>6,696</i>	2564 2231	<i>5,648</i> <i>4,914</i>				

- 519 SM Knuckleboom Loader
- 519 SM/EHC Knuckleboom Loader

Millyards Stationary Mount Knuckleboom Loaders

519 SM/519 SM/EHC 9.1 m (30'0") Boom

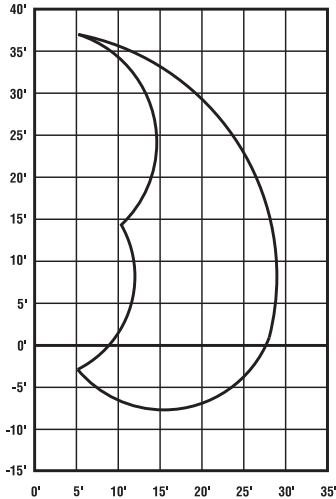

NOTES:

Do not attempt to lift or hold any load that is greater than the rated values over the end or side at their specified lift point and height. The weight of the grapple and all lifting accessories must be deducted from lift capacities shown.

1. All figures shown in these charts represent rated lift capacities.
2. Capacities shown in *italic* are 100% of hydraulic capacity; other capacities shown are 87% of hydraulic capability.
3. The lift point is located at the boom/grapple pivot pin.
4. Manufacturer assumes no responsibility for the proper fit or structural integrity of the mounting pedestal and/or platform supplied by the customer.
5. Operator should be fully acquainted with the Operator's Manual and all safety instructions furnished prior to operating the machine.
6. Lift capacities are in compliance with SAE J2417, "Lift Capacity Calculation Method – Knuckleboom Log Loaders and Certain Forestry Equipment."

5

	1.5 m/5'0"		3 m/10'0"		4.6 m/15'0"		6.1 m/20'0"		7.6 m/25'0"		9.1 m/30'0"	
	kg	lb	kg	lb	kg	lb	kg	lb	kg	lb	kg	lb
9.1 m (30'0")					4206 3659	<i>9,264</i> <i>8,060</i>						
7.6 m (25'0")					4714 4101	<i>10,384</i> <i>9,034</i>	3940 3428	<i>8,679</i> <i>7,551</i>				
6.1 m (20'0")							4179 3636	<i>9,206</i> <i>8,009</i>	3088 2687	<i>6,802</i> <i>5,918</i>		
4.6 m (15'0")					4419 3845	<i>9,734</i> <i>8,469</i>	4267 3712	<i>9,398</i> <i>8,176</i>	3713 3230	<i>8,178</i> <i>7,115</i>		
3.0 m (10'0")					4942 4300	<i>10,886</i> <i>9,471</i>	4488 3904	<i>9,885</i> <i>8,600</i>	3769 3279	<i>8,301</i> <i>7,222</i>		
1.5 m (5'0")					6380 5551	<i>14,053</i> <i>12,226</i>	5670 4933	<i>12,490</i> <i>10,866</i>	4407 3834	<i>9,707</i> <i>8,445</i>	1996 1737	<i>4,397</i> <i>3,825</i>
0 m (0'0")					8448 7350	<i>18,608</i> <i>16,189</i>	6299 5480	<i>13,874</i> <i>12,070</i>	4873 4239	<i>10,733</i> <i>9,338</i>		
-1.5 m (-5'0")			2892 2516	<i>6,369</i> <i>5,541</i>	7983 6945	<i>17,583</i> <i>15,297</i>	5894 5128	<i>12,983</i> <i>11,295</i>	4320 3758	<i>9,515</i> <i>8,278</i>		
-3.0 m (-10'0")	2039 1774	<i>4,492</i> <i>3,908</i>	4532 3943	<i>9,983</i> <i>8,685</i>	6538 5688	<i>14,401</i> <i>12,529</i>	4775 4154	<i>10,517</i> <i>9,150</i>	2937 2556	<i>6,470</i> <i>5,629</i>		
-4.6 m (-15'0")			4942 4299	<i>10,885</i> <i>9,470</i>	3981 3463	<i>8,768</i> <i>7,628</i>	2518 2191	<i>5,547</i> <i>4,826</i>				

Millyards Stationary Mount Knuckleboom Loaders

- ## Lift and Range Diagram
- 569 SM Knuckleboom Loader
 - 569 SM/EHC Knuckleboom Loader

569 SM/569 SM/EHC 9.6 m (32'6") Boom

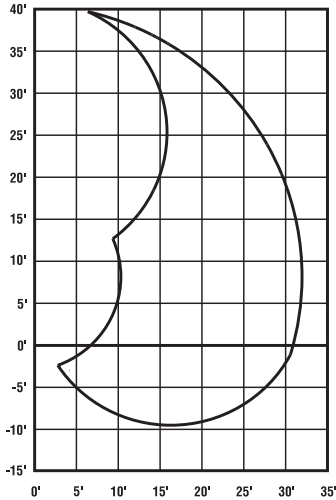

NOTES:

Do not attempt to lift or hold any load that is greater than the rated values over the end or side at their specified lift point and height. The weight of the grapple and all lifting accessories must be deducted from lift capacities shown.

1. All figures shown in these charts represent rated lift capacities.
2. Capacities shown in *italic* are 100% of hydraulic capacity; other capacities shown are 87% of hydraulic capability.
3. The lift point is located at the boom/grapple pivot pin.
4. Manufacturer assumes no responsibility for the proper fit or structural integrity of the mounting pedestal and/or platform supplied by the customer.
5. Operator should be fully acquainted with the Operator's Manual and all safety instructions furnished prior to operating the machine.
6. Lift capacities are in compliance with SAE J2417, "Lift Capacity Calculation Method – Knuckleboom Log Loaders and Certain Forestry Equipment."

	1.5 m/5'0"		3 m/10'0"		4.6 m/15'0"		6.1 m/20'0"		7.6 m/25'0"		9.1 m/30'0"	
	kg	lb	kg	lb	kg	lb	kg	lb	kg	lb	kg	lb
9.1 m (30'0")												
7.6 m (25'0")							5118 4453	<i>11,274</i> <i>9,808</i>				
6.1 m (20'0")							5850 5089	<i>12,885</i> <i>11,210</i>	4577 3982	<i>10,082</i> <i>8,771</i>		
4.6 m (15'0")							6422 5587	<i>14,145</i> <i>12,306</i>	5560 4837	<i>12,247</i> <i>10,655</i>	2997 2607	<i>6,601</i> <i>5,743</i>
3.0 m (10'0")					7558 6575	<i>16,647</i> <i>14,483</i>	7002 6091	<i>15,422</i> <i>13,417</i>	6115 5320	<i>13,470</i> <i>11,719</i>	4093 3561	<i>9,016</i> <i>7,844</i>
1.5 m (5'0")					10 730 9335	<i>23,634</i> <i>20,562</i>	8567 7453	<i>18,870</i> <i>16,417</i>	7127 6200	<i>15,698</i> <i>13,657</i>	4740 4124	<i>10,441</i> <i>9,084</i>
0 m (0'0")			18 803 16 359	<i>41,417</i> <i>36,033</i>	12 247 10 654	<i>26,975</i> <i>23,468</i>	9179 7985	<i>20,217</i> <i>17,589</i>	7305 6355	<i>16,090</i> <i>13,998</i>	4939 4297	<i>10,878</i> <i>9,464</i>
-1.5 m (-5'0")			9850 8569	<i>21,695</i> <i>18,875</i>	12 595 10 957	<i>27,741</i> <i>24,135</i>	9205 8008	<i>20,275</i> <i>17,639</i>	7026 6112	<i>15,475</i> <i>13,463</i>		
-3.0 m (-10'0")	3712 3230	<i>8,177</i> <i>7,114</i>	9507 8271	<i>20,940</i> <i>18,218</i>	11 367 9889	<i>25,037</i> <i>21,782</i>	8250 7178	<i>18,172</i> <i>15,810</i>	5897 5131	<i>12,990</i> <i>11,301</i>		

- 569 SM Knuckleboom Loader
- 569 SM/EHC Knuckleboom Loader

Millyards Stationary Mount Knuckleboom Loaders

569 SM/569 SM/EHC 10.9 m (36'0") Boom

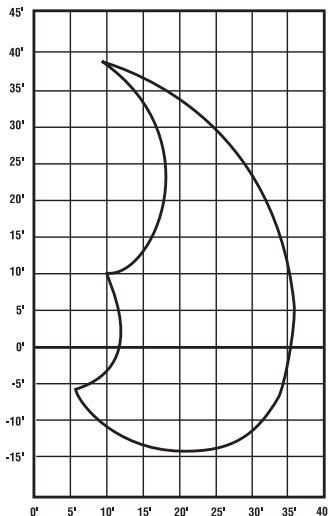

NOTES:

Do not attempt to lift or hold any load that is greater than the rated values over the end or side at their specified lift point and height. The weight of the grapple and all lifting accessories must be deducted from lift capacities shown.

1. All figures shown in these charts represent rated lift capacities.
2. Capacities shown in *italic* are 100% of hydraulic capacity; other capacities shown are 87% of hydraulic capability.
3. The lift point is located at the boom/grapple pivot pin.
4. Manufacturer assumes no responsibility for the proper fit or structural integrity of the mounting pedestal and/or platform supplied by the customer.
5. Operator should be fully acquainted with the Operator's Manual and all safety instructions furnished prior to operating the machine.
6. Lift capacities are in compliance with SAE J2417, "Lift Capacity Calculation Method – Knuckleboom Log Loaders and Certain Forestry Equipment."

5

	3 m/10'0"		4.6 m/15'0"		6.1 m/20'0"		7.6 m/25'0"		9.1 m/30'0"		10.6 m/35'0"	
	kg	lb	kg	lb	kg	lb	kg	lb	kg	lb	kg	lb
10.6 m (35'0")			<i>5110</i> 4446	<i>11,255</i> 9,792								
9.1 m (30'0")					4985 4337	<i>10,979</i> <i>9,552</i>						
7.6 m (25'0")					5744 4998	<i>12,653</i> <i>11,008</i>	4697 4086	<i>10,345</i> <i>9,000</i>				
6.1 m (20'0")					6087 5295	<i>13,407</i> <i>11,664</i>	5508 4792	<i>12,132</i> <i>10,555</i>	3943 3430	<i>8,685</i> <i>7,556</i>		
4.6 m (15'0")					6629 5767	<i>14,601</i> <i>12,703</i>	5997 5218	<i>13,210</i> <i>11,493</i>	5037 4382	<i>11,094</i> <i>9,652</i>		
3.0 m (10'0")			8808 7663	<i>19,400</i> <i>16,878</i>	7924 6894	<i>17,454</i> <i>15,185</i>	6701 5830	<i>14,761</i> <i>12,842</i>	5444 4737	<i>11,992</i> <i>10,433</i>	2748 2391	<i>6,053</i> <i>5,266</i>
1.5 m (5'0")			11 401 9919	<i>25,113</i> <i>21,848</i>	8652 7527	<i>19,057</i> <i>16,580</i>	7024 6111	<i>15,472</i> <i>13,461</i>	5873 5109	<i>12,936</i> <i>11,254</i>	3306 2877	<i>7,283</i> <i>6,336</i>
0 m (0'0")			12 364 10 757	<i>27,233</i> <i>23,693</i>	9096 7914	<i>20,036</i> <i>17,431</i>	7171 6239	<i>15,795</i> <i>13,742</i>	5804 5049	<i>12,784</i> <i>11,122</i>	3200 2784	<i>7,048</i> <i>6,132</i>
-1.5 m (-5'0")	4876 4242	<i>10,740</i> <i>9,344</i>	12 156 10 575	<i>26,775</i> <i>23,294</i>	8973 7806	<i>19,763</i> <i>17,194</i>	6956 6051	<i>15,321</i> <i>13,329</i>	5420 4716	<i>11,939</i> <i>10,387</i>		
-3.0 m (-10'0")	5803 5049	<i>12,783</i> <i>11,121</i>	10 713 9321	<i>23,598</i> <i>20,530</i>	8081 7030	<i>17,799</i> <i>15,485</i>	6170 5368	<i>13,591</i> <i>11,824</i>	4454 3875	<i>9,810</i> <i>8,535</i>		

Wheel Loader Forestry Features:

988K — Logging Arrangement equips the 988K with larger lift and tilt cylinders, additional counterweight, and 3V hydraulics. Heavy-duty tires (42PR or **) are required for the strength and durability required in millyard applications. Work tool attachments, such as logging forks are designed for heavy-duty applications; loading and unloading trucks, sorting, decking and feeding the mill.

990H — The 990H Millyard Arrangement equips the machine with larger lift and tilt cylinders, extra counterweight, and 3V hydraulics for top clamp control. The larger machine is recommended for millyards which may have uneven terrain where more stability is required.

980M/980K/980H — Forest Machine Arrangement equips the 980M, 980K, and 980H with an extreme service transmission, heavy-duty tilt cylinders and additional counterweight for the strength and durability required to be productive in this tough application. Logging, millyard and wood pallet forks, woodchip and clean-up buckets can be added to equip the machines for forestry applications.

966M/966K/966H — Forest Machine Arrangements on the 966M, 966K, and 966H provide ride control, heavy-duty tilt cylinders and an additional counterweights for use in forestry and logging applications. Specially designed work tools for forestry applications can be factory-installed.

950M/962M/950K/962K/950H — Forest Machine Arrangements on the 950M, 962M, 950K, 962K and 950H provide ride control, heavy-duty tilt cylinders and an additional counterweights for use in forestry and logging applications. Specially designed work tools for forestry applications can be factory-installed.

MODEL	988K	
Operating Weight	61 241 kg	135,014 lb
Engine Model	C18 ACERT	
Full Turn Static Tipping Load (Logging Forks)	31 079 kg	68,517 lb
	@ 37 degree articulation	

**988K with Pin-On
Cat Logging Fork**

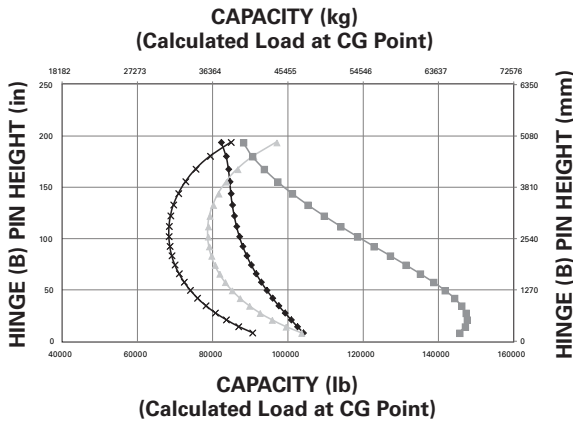

**990H with Pin-On
Cat Logging Fork**

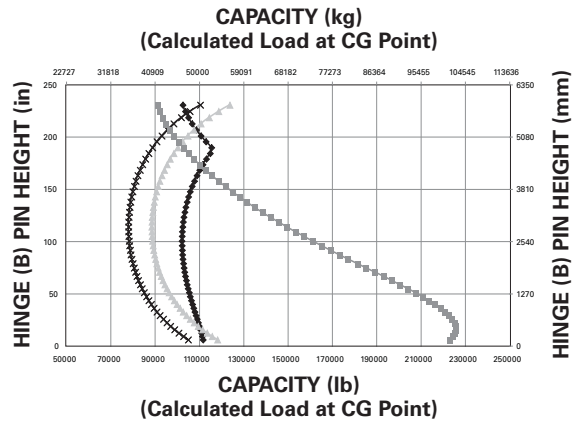

5

KEY

- ◆ Lift Capacity — Level Fork (988K)
- ▲ Straight Tipping — Level Fork (988K)
- ✕ 37° Tipping — Level Fork (988K)
- Tilt Capacity — Level Fork (988K)

Curves based on machine with full fuel tank, operator, ROPS cab, 35/65R33 ** (L-4) tires. Extra counterweight as supplied with Millyard Arrangement and 431-6176 double top clamp log fork. Total operating weight 63 600 kg (139,920 lb).

KEY

- ◆ Lift Capacity
- ✕ Articulated Tipping
- ▲ Straight Tipping
- Tilt Capacity

Curves based on machine with full fuel tank, operator, ROPS cab, 45/65R39 tires. Extra counterweight as supplied by Millyard Arrangement. 315-0458 millyard forks. Total operating weight 89 963 kg (197,919 lb).

NOTE: Static tipping load and operating weight are based on machine configuration with standard tires, full fuel tank, coolant, lubricants, and operator.

Specifications and ratings conform to all applicable standards recommended by the Society of Automotive Engineers (SAE). SAE Standards J732 JUN92 and J742 FEB85 govern loader ratings.

The rated operating load for a machine with fork is: SAE J1197; 50% of full turn static tipping load, or hydraulic/structural limit. CEN 474-3: 60% of full turn tipping load on rough terrain; 80% of full turn tipping load on firm and level ground, or hydraulic structural limit.

- 924K
- 930K

**924K with Fusion™ Coupler
Cat Log and Lumber Fork**

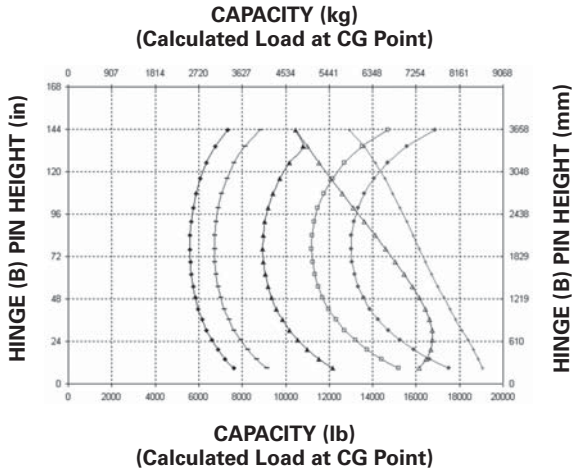

**930K with Fusion Coupler
Cat Log and Lumber Fork**

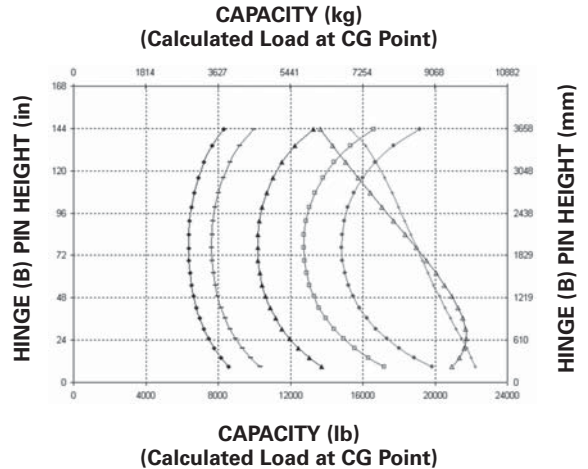

KEY

- ◆ Payload (SAE J1197)
- Payload (EN 474-3 Rough Terrain)
- ▲ Payload (EN 474-3 Firm and Level)
- ⊠ Static Tipping Load — Articulated
- ◆ Static Tipping Load — Straight
- ▲ Hydraulic Tilt Capacity (Level Tool)
- ⊠ Hydraulic Lift Capacity (Level Tool)

Curves based on machine with Michelin 20.5R25 XHA2 tires, logger counterweight, additional guarding, 80 kg (176 lb) operator, full fuel tank, and 399-0708 log and lumber fork with 1829 mm (72") tines. Fork weight is 1181 kg (2604 lb) and machine operating weight is 13 522 kg (29,811 lb).

Curves based on machine with Michelin 20.5R25 XHA2 tires, logger counterweight, additional guarding, 80 kg (176 lb) operator, full fuel tank, and 399-0708 log and lumber fork with 1829 mm (72") tines. Fork weight is 1181 kg (2604 lb) and machine operating weight is 14 440 kg (31,835 lb).

NOTE: Specifications and ratings conform to all applicable standards recommended by the Society of Automotive Engineers (SAE). SAE Standards J732 JUN92 and J742 FEB85 govern loader ratings.

**938K with Fusion Coupler
Cat Log and Lumber Fork**

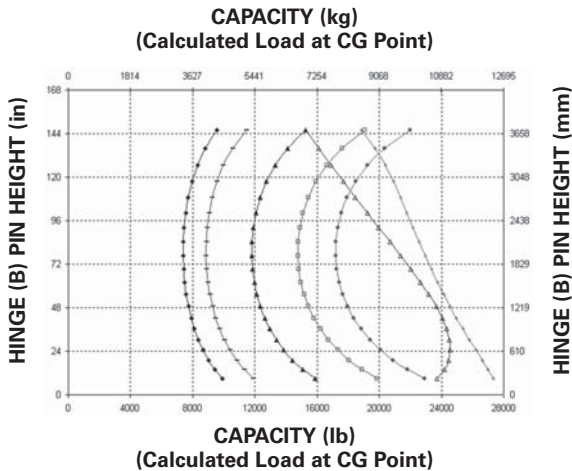

**924K with Fusion Coupler
Cat Millyard Fork**

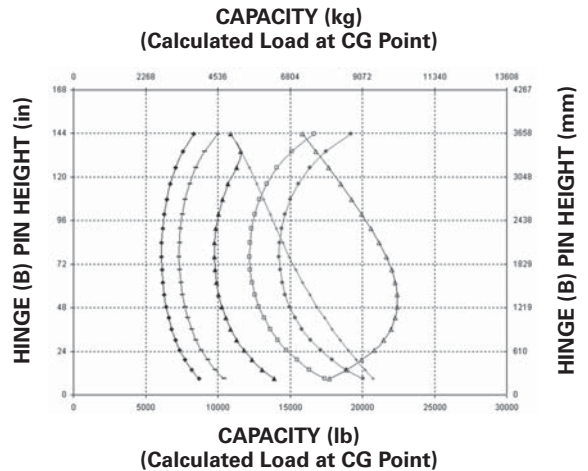

KEY

- ◆ Payload (SAE J1197)
- Payload (EN 474-3 Rough Terrain)
- ▲ Payload (EN 474-3 Firm and Level)
- ⊠ Static Tipping Load — Articulated
- ◆ Static Tipping Load — Straight
- ▲ Hydraulic Tilt Capacity (Level Tool)
- ⊠ Hydraulic Lift Capacity (Level Tool)

Curves based on machine with Michelin 20.5R25 XHA2 tires, logger counterweight, additional guarding, 80 kg (176 lb) operator, full fuel tank, and 399-0708 log and lumber fork with 1829 mm (72") tines. Fork weight is 1181 kg (2604 lb) and machine operating weight is 16 322 kg (35,974 lb).

Curves based on machine with Michelin 20.5R25 XHA2 tires, logger counterweight, additional guarding, 80 kg (176 lb) operator, full fuel tank, and 415-4023 millyard fork with top clamp and 1524 mm (60") tines. Fork weight is 1457 kg (3212 lb) and machine operating weight is 13 798 kg (30,419 lb).

NOTE: Specifications and ratings conform to all applicable standards recommended by the Society of Automotive Engineers (SAE). SAE Standards J732 JUN92 and J742 FEB85 govern loader ratings.

- 930K
- 938K

**930K with Fusion Coupler
Cat Millyard Fork**

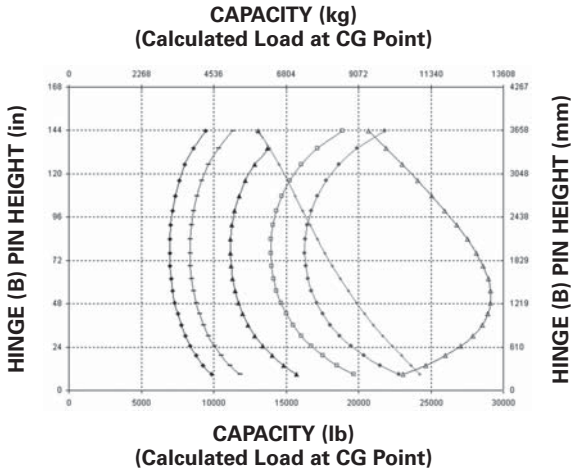

**938K with Fusion Coupler
Cat Millyard Fork**

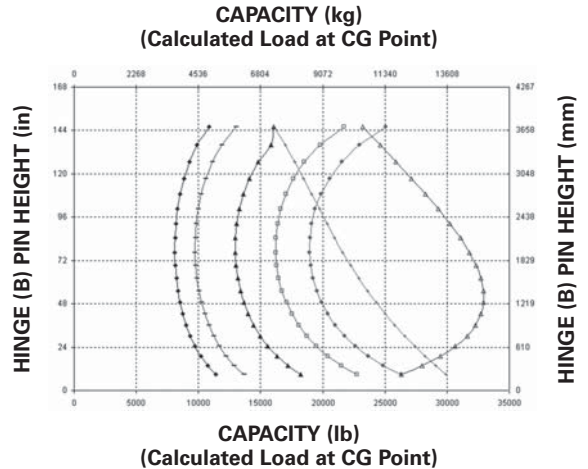

KEY

- ◆ Payload (SAE J1197)
- Payload (EN 474-3 Rough Terrain)
- ▲ Payload (EN 474-3 Firm and Level)
- ▣ Static Tipping Load — Articulated
- ◆ Static Tipping Load — Straight
- ▲ Hydraulic Tilt Capacity (Level Tool)
- ⊕ Hydraulic Lift Capacity (Level Tool)

Curves based on machine with Michelin 20.5R25 XHA2 tires, logger counterweight, additional guarding, 80 kg (176 lb) operator, full fuel tank, and 415-4023 millyard fork with top clamp and 1524 mm (60") tines. Fork weight is 1457 kg (3212 lb) and machine operating weight is 14 716 kg (32,443 lb).

Curves based on machine with Michelin 20.5R25 XHA2 tires, logger counterweight, additional guarding, 80 kg (176 lb) operator, full fuel tank, and 415-4023 millyard fork with top clamp and 1524 mm (60") tines. Fork weight is 1457 kg (3212 lb) and machine operating weight is 16 598 kg (36,592 lb).

NOTE: Specifications and ratings conform to all applicable standards recommended by the Society of Automotive Engineers (SAE). SAE Standards J732 JUN92 and J742 FEB85 govern loader ratings.

950M LOG
Millyard Fork, Pin-On

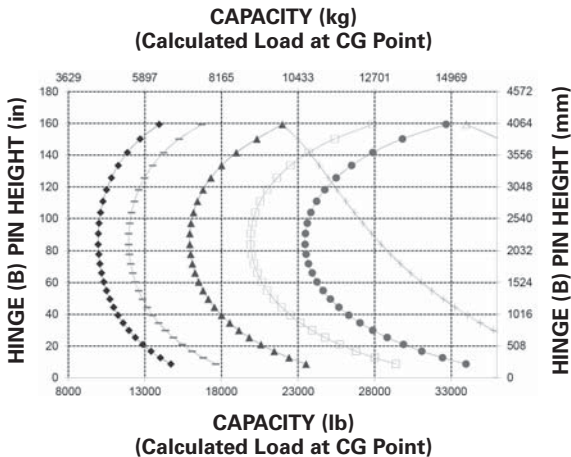

950M LOG
Millyard Pole Fork, Fusion

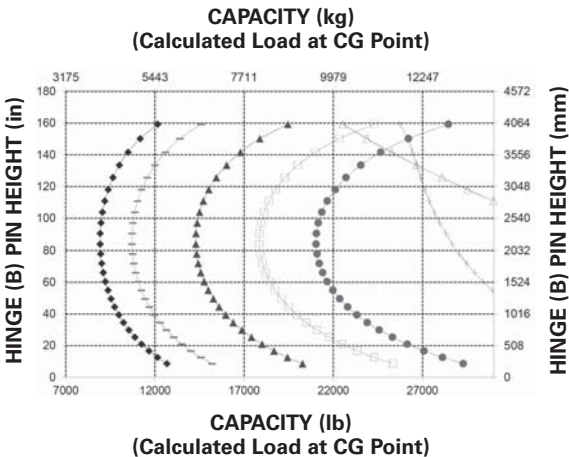

5

KEY

- ◆ Payload (SAE J1197)
- Payload (CEN EN 474-3 Rough Terrain)
- ▲ Payload (CEN EN 474-3 Firm and Level)
- ⊕ Static Tipping Load – Articulated
- Static Tipping Load – Straight
- △ Hydraulic Tilt Capacity
- ⊕ Hydraulic Lift Capacity

NOTE: Static tipping loads and operating weight are based on the following loader configuration: L3 Michelin XHA Tires, Air Conditioning, Ride Control, Power Train Guard, Full Fluids, Fuel Tank, Coolant, Lubricants, and Operator.

Specifications and ratings conform to the following standards: SAE* J1197, SAE J732, CEN** EN 474-3.

The rated operating load for a loader equipped with a pallet fork is determined by:

- SAE J1197: 50% of full turn static tipping load or hydraulic limit.
- CEN EN 474-3: 60% of full turn static tipping load on rough terrain or hydraulic limit.
- CEN EN 474-3: 80% of full turn static tipping load on firm and level ground or hydraulic limit.

*SAE – Society of Automotive Engineers

**CEN – European Committee for Standardization

**950M LOG
Grapple Fork, Pin-On**

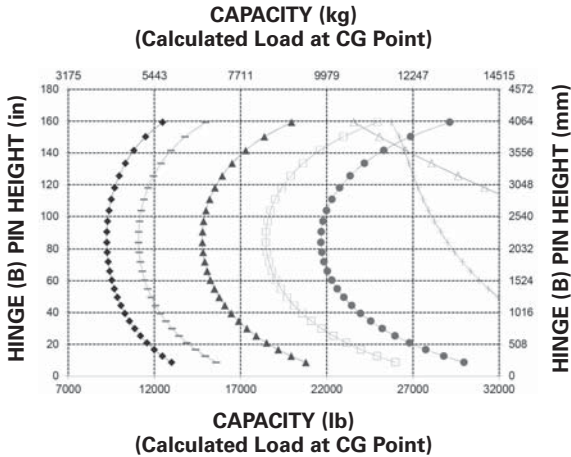

**950M LOG
UFO Grapple Fork, Fusion**

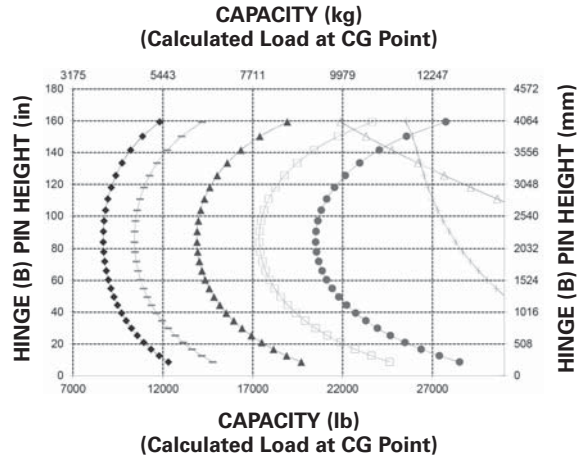

KEY

- ◆ Payload (SAE J1197)
- Payload (CEN EN 474-3 Rough Terrain)
- ▲ Payload (CEN EN 474-3 Firm and Level)
- ⊕ Static Tipping Load — Articulated
- Static Tipping Load — Straight
- △ Hydraulic Tilt Capacity
- + Hydraulic Lift Capacity

NOTE: Static tipping loads and operating weight are based on the following loader configuration: L3 Michelin XHATires, Air Conditioning, Ride Control, Power Train Guard, Full Fluids, Fuel Tank, Coolant, Lubricants, and Operator.

Specifications and ratings conform to the following standards: SAE* J1197, SAE J732, CEN** EN 474-3.

The rated operating load for a loader equipped with a pallet fork is determined by:

- SAE J1197: 50% of full turn static tipping load or hydraulic limit.
- CEN EN 474-3: 60% of full turn static tipping load on rough terrain or hydraulic limit.
- CEN EN 474-3: 80% of full turn static tipping load on firm and level ground or hydraulic limit.

*SAE — Society of Automotive Engineers

**CEN — European Committee for Standardization

950M LOG

UFO Grapple Fork, Volvo Comp QC

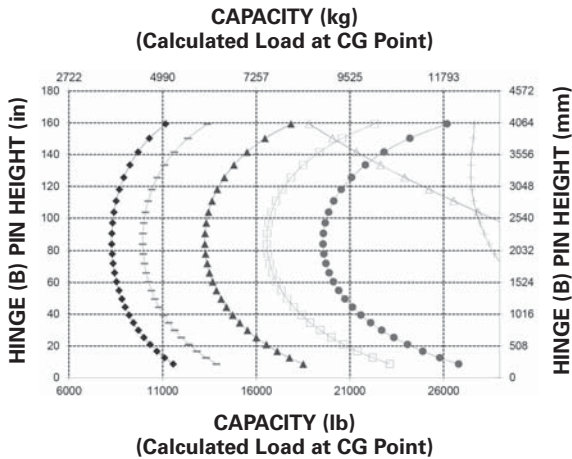

962M LOG

Millyard Pole Fork, Fusion

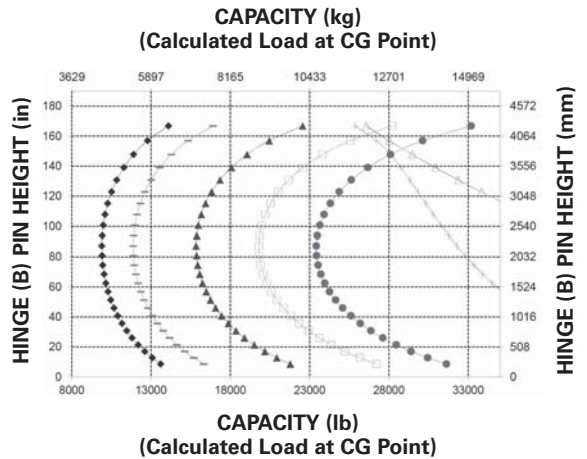

KEY

- ◆ Payload (SAE J1197)
- Payload (CEN EN 474-3 Rough Terrain)
- ▲ Payload (CEN EN 474-3 Firm and Level)
- ⊕ Static Tipping Load – Articulated
- Static Tipping Load – Straight
- △ Hydraulic Tilt Capacity
- ⊕ Hydraulic Lift Capacity

NOTE: Static tipping loads and operating weight are based on the following loader configuration: L3 Michelin XHA Tires, Air Conditioning, Ride Control, Power Train Guard, Full Fluids, Fuel Tank, Coolant, Lubricants, and Operator.

Specifications and ratings conform to the following standards: SAE* J1197, SAE J732, CEN** EN 474-3.

The rated operating load for a loader equipped with a pallet fork is determined by:

- SAE J1197: 50% of full turn static tipping load or hydraulic limit.
- CEN EN 474-3: 60% of full turn static tipping load on rough terrain or hydraulic limit.
- CEN EN 474-3: 80% of full turn static tipping load on firm and level ground or hydraulic limit.

*SAE – Society of Automotive Engineers

**CEN – European Committee for Standardization

962M LOG
UFO Grapple Fork, Fusion

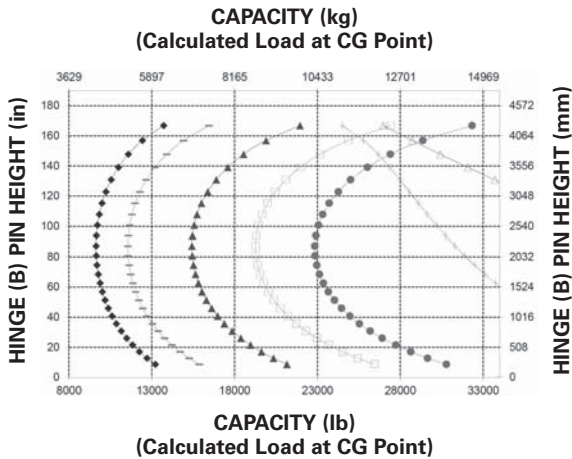

962M LOG
UFO Grapple Fork, Volvo Comp QC

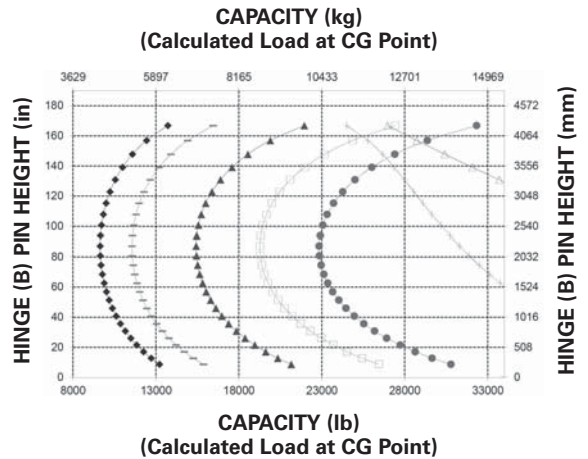

KEY

- ◆ Payload (SAE J1197)
- Payload (CEN EN 474-3 Rough Terrain)
- ▲ Payload (CEN EN 474-3 Firm and Level)
- ◻ Static Tipping Load – Articulated
- Static Tipping Load – Straight
- △ Hydraulic Tilt Capacity
- + Hydraulic Lift Capacity

NOTE: Static tipping loads and operating weight are based on the following loader configuration: L3 Michelin XHA Tires, Air Conditioning, Ride Control, Power Train Guard, Full Fluids, Fuel Tank, Coolant, Lubricants, and Operator.

Specifications and ratings conform to the following standards: SAE* J1197, SAE J732, CEN** EN 474-3.

The rated operating load for a loader equipped with a pallet fork is determined by:

- SAE J1197: 50% of full turn static tipping load or hydraulic limit.
- CEN EN 474-3: 60% of full turn static tipping load on rough terrain or hydraulic limit.
- CEN EN 474-3: 80% of full turn static tipping load on firm and level ground or hydraulic limit.

*SAE – Society of Automotive Engineers

**CEN – European Committee for Standardization

966M LOG
Millyard Fork, Fusion

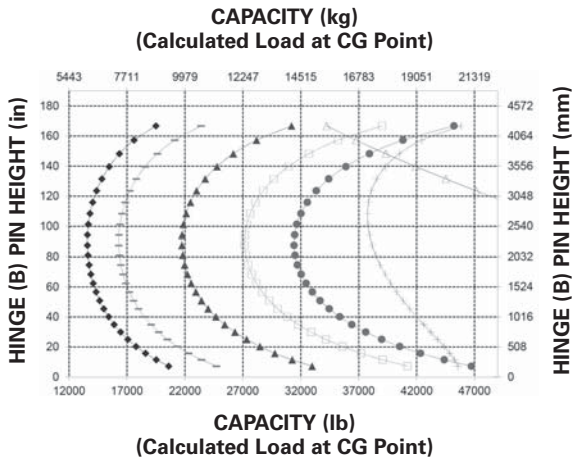

966M LOG
Millyard Pole Fork, Pin-On

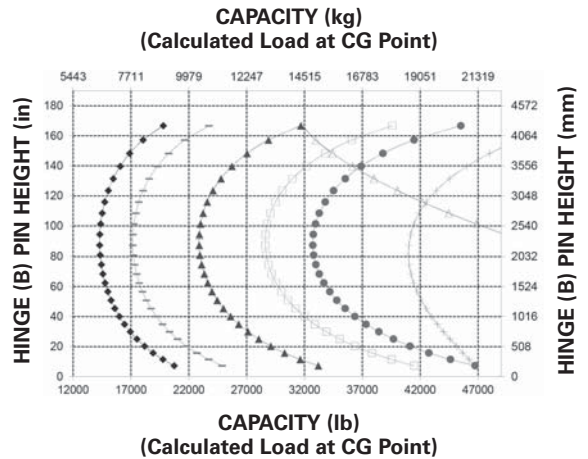

5

KEY

- ◆ Payload (SAE J1197)
- Payload (CEN EN 474-3 Rough Terrain)
- ▲ Payload (CEN EN 474-3 Firm and Level)
- ⊕ Static Tipping Load – Articulated
- Static Tipping Load – Straight
- △ Hydraulic Tilt Capacity
- ⊕ Hydraulic Lift Capacity

NOTE: Static tipping loads and operating weight are based on the following loader configuration: L3 Michelin XHA Tires, Air Conditioning, Ride Control, Power Train Guard, Full Fluids, Fuel Tank, Coolant, Lubricants, and Operator.

Specifications and ratings conform to the following standards: SAE* J1197, SAE J732, CEN** EN 474-3.

The rated operating load for a loader equipped with a pallet fork is determined by:

- SAE J1197: 50% of full turn static tipping load or hydraulic limit.
- CEN EN 474-3: 60% of full turn static tipping load on rough terrain or hydraulic limit.
- CEN EN 474-3: 80% of full turn static tipping load on firm and level ground or hydraulic limit.

*SAE – Society of Automotive Engineers

**CEN – European Committee for Standardization

- 966M
- 980M

**966M LOG
Grapple Fork, Pin-On**

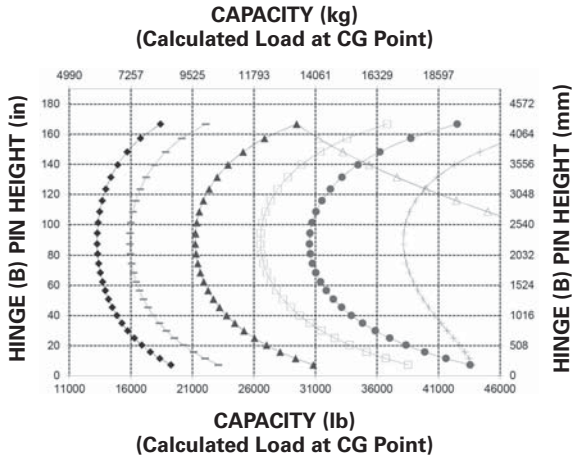

**980M LOG
Millyard, Pin-On**

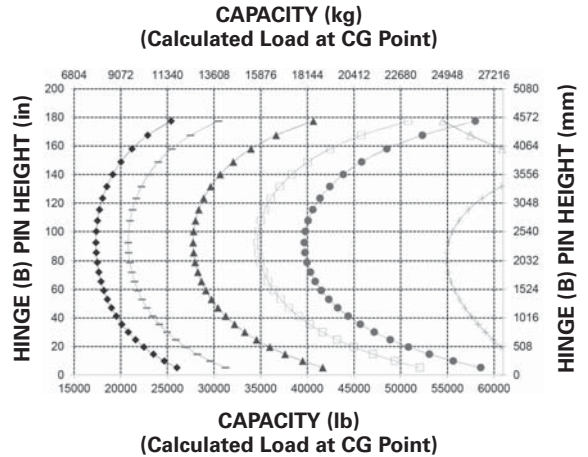

KEY

- ◆ Payload (SAE J1197)
- Payload (CEN EN 474-3 Rough Terrain)
- ▲ Payload (CEN EN 474-3 Firm and Level)
- ⊕ Static Tipping Load — Articulated
- Static Tipping Load — Straight
- △ Hydraulic Tilt Capacity
- ⊕ Hydraulic Lift Capacity

NOTE: Static tipping loads and operating weight are based on the following loader configuration: L3 Michelin XHA Tires, Air Conditioning, Ride Control, Power Train Guard, Full Fluids, Fuel Tank, Coolant, Lubricants, and Operator.

Specifications and ratings conform to the following standards: SAE* J1197, SAE J732, CEN** EN 474-3.

The rated operating load for a loader equipped with a pallet fork is determined by:

- SAE J1197: 50% of full turn static tipping load or hydraulic limit.
- CEN EN 474-3: 60% of full turn static tipping load on rough terrain or hydraulic limit.
- CEN EN 474-3: 80% of full turn static tipping load on firm and level ground or hydraulic limit.

*SAE — Society of Automotive Engineers

**CEN — European Committee for Standardization

966K LOG
Logging Fork, Pin-On

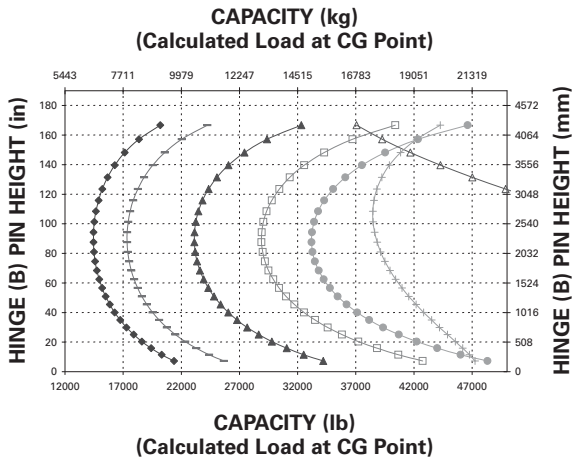

950H LOG
Millyard Fork, Pin-On

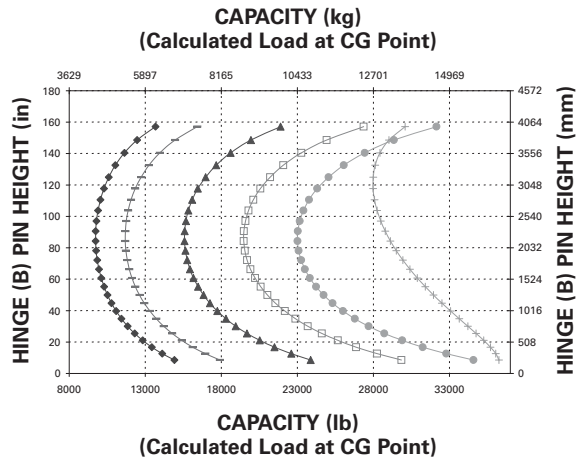

KEY

- ◆ Payload (SAE J1197)
- Payload (CEN EN 474-3 Rough Terrain)
- ▲ Payload (CEN EN 474-3 Firm and Level)
- Static Tipping Load – Articulated
- Static Tipping Load – Straight
- △ Hydraulic Tilt Capacity
- + Hydraulic Lift Capacity

NOTE: Static tipping loads and operating weight are based on the following loader configuration: L3 Michelin XHATires, Air Conditioning, Ride Control, Power Train Guard, Full Fluids, Fuel Tank, Coolant, Lubricants, and Operator.

Specifications and ratings conform to the following standards: SAE* J1197, SAE J732, CEN** EN 474-3.

The rated operating load for a loader equipped with a pallet fork is determined by:

- SAE J1197: 50% of full turn static tipping load or hydraulic limit.
- CEN EN 474-3: 60% of full turn static tipping load on rough terrain or hydraulic limit.
- CEN EN 474-3: 80% of full turn static tipping load on firm and level ground or hydraulic limit.

*SAE — Society of Automotive Engineers

**CEN — European Committee for Standardization

The 966K and 950H are not available in all regions. Contact your local Cat dealer for product availability.

**966H LOG
Millyard Fork, Pin-On**

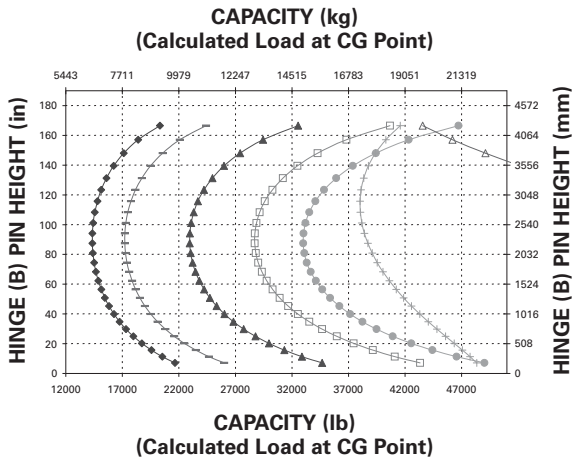

**966H LOG
Grapple Fork, Pin-On**

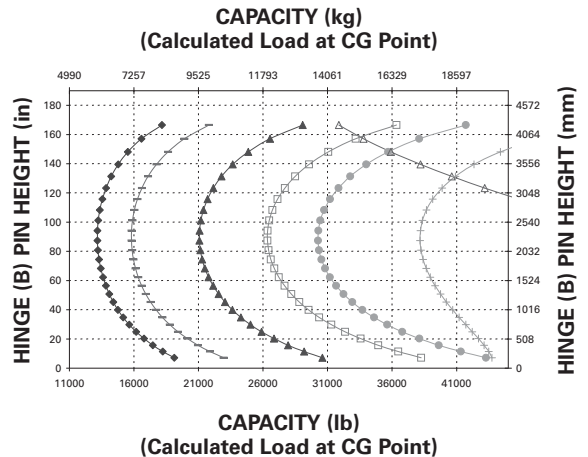

KEY

- ◆ Payload (SAE J1197)
- Payload (CEN EN 474-3 Rough Terrain)
- ▲ Payload (CEN EN 474-3 Firm and Level)
- Static Tipping Load — Articulated
- Static Tipping Load — Straight
- △ Hydraulic Tilt Capacity
- + Hydraulic Lift Capacity

NOTE: Static tipping loads and operating weight are based on the following loader configuration: L3 Michelin XHA Tires, Air Conditioning, Ride Control, Power Train Guard, Full Fluids, Fuel Tank, Coolant, Lubricants, and Operator.

Specifications and ratings conform to the following standards: SAE* J1197, SAE J732, CEN** EN 474-3.

The rated operating load for a loader equipped with a pallet fork is determined by:

- SAE J1197: 50% of full turn static tipping load or hydraulic limit.
- CEN EN 474-3: 60% of full turn static tipping load on rough terrain or hydraulic limit.
- CEN EN 474-3: 80% of full turn static tipping load on firm and level ground or hydraulic limit.

*SAE — Society of Automotive Engineers

**CEN — European Committee for Standardization

The 966H is not available in all regions. Contact your local Cat dealer for product availability.

980H LOG
Millyard Fork, Pin-On

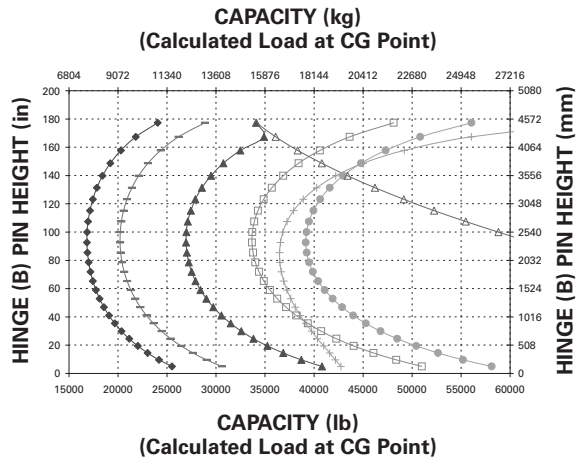

KEY

- ◆ Payload (SAE J1197)
- Payload (CEN EN 474-3 Rough Terrain)
- ▲ Payload (CEN EN 474-3 Firm and Level)
- ◻ Static Tipping Load – Articulated
- Static Tipping Load – Straight
- △ Hydraulic Tilt Capacity
- + Hydraulic Lift Capacity

NOTE: Static tipping loads and operating weight are based on the following loader configuration: L3 Michelin XHA Tires, Air Conditioning, Ride Control, Power Train Guard, Full Fluids, Fuel Tank, Coolant, Lubricants, and Operator.

Specifications and ratings conform to the following standards: SAE* J1197, SAE J732, CEN** EN 474-3.

The rated operating load for a loader equipped with a pallet fork is determined by:

- SAE J1197: 50% of full turn static tipping load or hydraulic limit.
- CEN EN 474-3: 60% of full turn static tipping load on rough terrain or hydraulic limit.
- CEN EN 474-3: 80% of full turn static tipping load on firm and level ground or hydraulic limit.

*SAE — Society of Automotive Engineers

**CEN — European Committee for Standardization

The 980H is not available in all regions. Contact your local Cat dealer for product availability.

586C Site Prep Tractor Features:

- The C Series has been designed for **maximum performance and increased model versatility** to meet multi-customer applications.
- Durable Cat C9 and C9.3 Engines with ACERT Technology meet the demanding power requirements of site prep tractor applications while meeting Tier 4 Interim/Stage IIIB/Japan 2011 (Tier 4 Interim) or Tier 3/Stage IIIA/Japan 2006 (Tier 3) equivalent emission standards.
- The **high capacity cooling system**, with a hydraulic on-demand reversing fan, is designed to operate in high ambient air temperatures and extremely high debris applications while improving component life.
- The **load sense hydraulic systems** provide power on demand and multi-functioning capabilities to all functions of the machine while minimizing fuel consumption. **Cold weather system protections** have been designed into the system to maximize component durability.
- **PowerDirect Plus** optimizes the machine's performance, including the **high performance attachment hydraulic system**, by monitoring operator and attachment demand and delivering power where and when it is needed.
- A **robust drivetrain** includes a proven hydrostatic drive system, robust Cat axles, and **propel creep control** with on the fly adjustability to infinitely adjust ground speed for the application.
- **Heavy duty structures** utilize stream line box section design features, field proven dual taper roller bearing hitch design, integrated steering cylinder mounts, parent plate steering cylinder mounts and oversized chrome plated pins to provide increased life.
- The **transverse mounted engine** provides superior machine stability and ride quality while providing superior engine service, ground level fuel fill, hinged service panels, and pressurized engine/hydraulic and Cat emissions module compartments minimizing potential debris accumulation.
- **Serviceability** has been improved by the transverse mounted engine and other standard features like an electric hydraulic oil fill pump, tilting cab, strategic bulk heads and routings to improve hose and wire harness life and serviceability, and machine fault codes displayed as a text message on the machine monitor to minimize downtime for daily checks, preventative maintenance, and emergency service.
- The **refined operator's station** is positioned between the axles to provide excellent ride quality along with the standard air suspension seat, high capacity HVAC system, and ergonomic controls to reduce operator fatigue. The **attachment float control** option also reduces operator fatigue and improves performance.

MODEL	586C HRC		586C LRC	
Gross Power (ISO 14396)	261 kW	350 hp	261 kW	350 hp
Engine Model	C9.3 ACERT		C9 ACERT	
Engine Speed	1880 RPM		1880 RPM	
Travel Speed:				
Low Range with 30.5L-32 Tires	0-8.4 km/h	0-5.2 mph	0-8.4 km/h	0-5.2 mph
High Range with 30.5L-32 Tires	0-20.0 km/h	0-12.4 mph	0-20.0 km/h	0-12.4 mph
Hydrostatic Drive Pump (variable displacement piston pump)	242 L/min @ 37 370 kPa	64 gpm @ 5420 psi	242 L/min @ 37 370 kPa	64 gpm @ 5420 psi
Primary Hydraulic Pump (variable displacement piston pump)	155 L/min @ 27 579 kPa	41 gpm @ 4000 psi	155 L/min @ 27 579 kPa	41 gpm @ 4000 psi
Attachment Pump (variable displacement piston pump)	378 L/min @ 37 921 kPa	100 gpm @ 5500 psi	378 L/min @ 37 921 kPa	100 gpm @ 5500 psi
Fuel Capacity	494 L	130.5 U.S. gal	494 L	130.5 U.S. gal
Weight*	17 440 kg	38,450 lb	17 214 kg	37,950 lb

*Weight includes Quick Coupler, Retrieval Assist Winch with Cable, and Full Fluids. Subtract 164 kg (362 lb) for 28L-26Tires and add 40 kg (88 lb) for 67-34Tires.

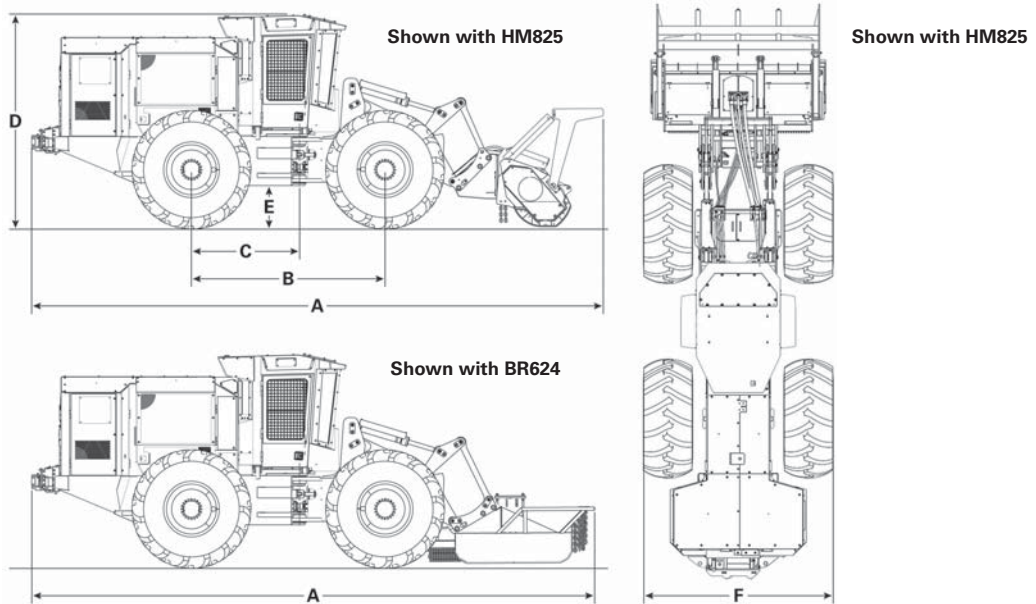

MODEL	586C HRC		586C LRC	
A Overall Length*:				
Length (with HM825)	9000 mm	354.3"	9000 mm	354.3"
Length (with BR624)	8855 mm	348.6"	8855 mm	348.6"
B Wheelbase	3048 mm	120"	3048 mm	120"
C Rear Axle Center Line to Hitch Pin	1702 mm	67"	1702 mm	67"
D Overall Height**:				
28L-26, NOAW	3223 mm	126.9"	3223 mm	126.9"
28L-26, STD	3223 mm	126.9"	3223 mm	126.9"
30.5L-32, NOAW	3324 mm	130.9"	3324 mm	130.9"
30.5L-32, STD	3324 mm	130.9"	3324 mm	130.9"
67-34, STD	3251 mm	128.0"	3251 mm	128.0"
E Ground Clearance:				
28L-26, NOAW	527.2 mm	20.8"	527.2 mm	20.8"
28L-26, STD	527.2 mm	20.8"	527.2 mm	20.8"
30.5L-32, NOAW	628.2 mm	24.7"	628.2 mm	24.7"
30.5L-32, STD	628.2 mm	24.7"	628.2 mm	24.7"
67-34, STD	555.2 mm	21.9"	555.2 mm	21.9"
F Overall Width:				
28L-26, NOAW	2793 mm	110.0"	2793 mm	110.0"
28L-26, STD	2920 mm	115.0"	2920 mm	115.0"
30.5L-32, NOAW	2980 mm	117.3"	2980 mm	117.3"
30.5L-32, STD	3140 mm	123.6"	3140 mm	123.6"
67-34, STD	3222 mm	126.9"	3222 mm	126.9"

*Subtract 214 mm (8.4") for Tow Hooks in lieu of Retrieval Assist Winch.
 **Add 211 mm (8.3") for Road Ready Light Package.

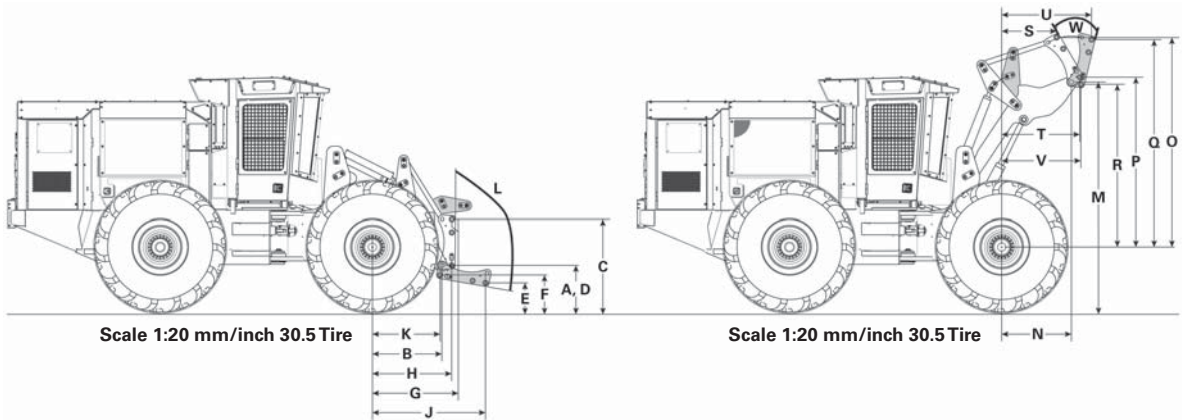

Dimensions shown represent machine with 30.5L-32 Tires and Quick Coupler

MODEL	586C HRC		586C LRC	
Lift Arm Lowered Position — Hinge Pin Location:				
A Hinge Pin Height*	591 mm	23.3"	591 mm	23.3"
B Hinge Pin Reach	997 mm	39.3"	997 mm	39.3"
Lift Arm Lowered Position — Quick Coupler Pin Locations:				
C Retracted Upper Pin Height*	1250 mm	49.2"	1250 mm	49.2"
D Retracted Lower Pin Height*	591 mm	23.3"	591 mm	23.3"
E Extended Upper Pin Height*	338 mm	13.3"	338 mm	13.3"
F Extended Lower Pin Height*	452 mm	17.8"	452 mm	17.8"
G Retracted Upper Pin Reach	1141 mm	44.9"	1141 mm	44.9"
H Retracted Lower Pin Reach	1121 mm	44.1"	1121 mm	44.1"
J Extended Upper Pin Reach	1624 mm	63.9"	1624 mm	63.9"
K Extended Lower Pin Reach	913 mm	35.9"	913 mm	35.9"
L Quick Coupler Range of Motion	99.6°		99.6°	
Lift Arm Raised Position — Hinge Pin Location:				
M Hinge Pin Height*	3217 mm	126.7"	3217 mm	126.7"
N Hinge Pin Reach	1001 mm	39.4"	1001 mm	39.4"
Lift Arm Raised Position — Quick Coupler Pin Locations:				
O Retracted Upper Pin Height*	3005 mm	118.3"	3005 mm	118.3"
P Retracted Lower Pin Height*	2435 mm	95.9"	2435 mm	95.9"
Q Extended Upper Pin Height*	2975 mm	117.1"	2975 mm	117.1"
R Extended Lower Pin Height*	2332 mm	91.8"	2332 mm	91.8"
S Retracted Upper Pin Reach	789 mm	31.0"	789 mm	31.0"
T Retracted Lower Pin Reach	1122 mm	44.2"	1122 mm	44.2"
U Extended Upper Pin Reach	1290 mm	50.7"	1290 mm	50.7"
V Extended Lower Pin Reach	1137 mm	44.8"	1137 mm	44.8"
W Quick Coupler Range of Motion	43.6°		43.6°	

*Subtract 101 mm (4.0") for 28L-26Tires and 73 mm (2.9") for 67-34Tires.

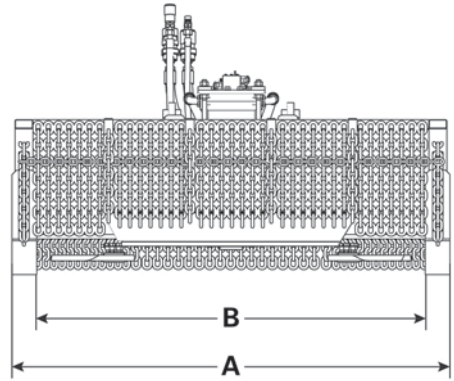
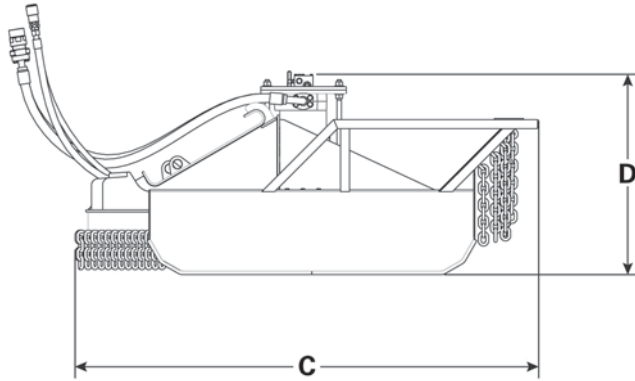

MODEL

BR624

A Overall Width	2474 mm	97.4"
B Working Width	2193 mm	86.3"
C Length	2618 mm	103.1"
D Height	873 mm	44.4"
Weight	2631 kg	5800 lb
Drive Method	Direct Mount Rotor Bar	
Hydraulic Motor Type	Single Speed Axial Piston	
Optimum Hydraulic Flow Range	246 L/min	65 gpm
Optimum Hydraulic Pressure Range	37 921 kPa	5500 psi
Optimum Speed	950 RPM	
Number of Blades	2	
Maximum Diameter of Material to be Cut	203 mm	8"

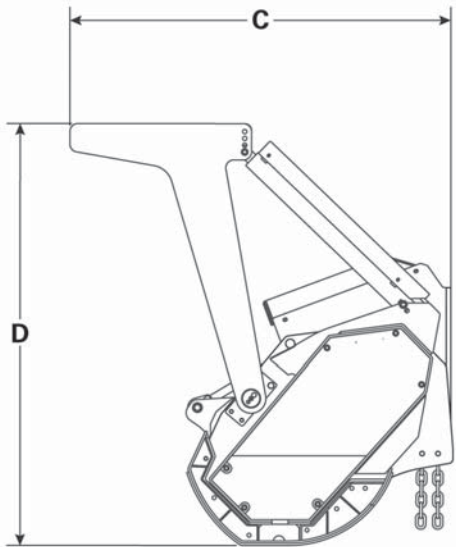
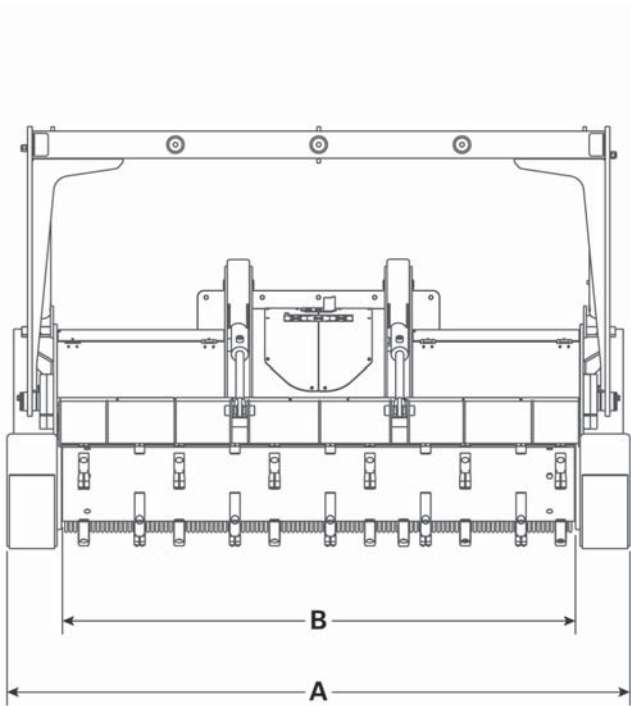

5

MODEL

HM825

A Overall Width	2900 mm	114.2"
B Working Width	2540 mm	100.0"
C Length	1677 mm	66.0"
D Height	1859 mm	73.2"
Weight	3697 kg	8150 lb
Drive Method	Polychain Belt	
Hydraulic Motor Type	Dual Speed Axial Piston	
Optimum Hydraulic Flow Range	378 L/min	100 gpm
Optimum Hydraulic Pressure Range	37 921 kPa	5500 psi
Optimum Drum Speed	1200-1800 RPM	
Number of Teeth	58	
Maximum Diameter of Material to be Cut	406 mm	16"

WORK TOOLS

Grapples for Heel Boom Log Loaders
 Features 5-103
 Dimensions 5-104

Logging Forks
 Features 5-105
 Specifications 5-105

Couplers
 Features 5-110

Buckets and Thumbs
 Features 5-110

Woodchip Dozers and Scoops
 Features 5-111
 Specifications 5-111

Rakes
 Features 5-112

Features:

- **Full 360° continuous rotation.**
- **Paddle style tines** are made of high strength steel, and use abrasion resistant material on tips for longer life.
- **Induction hardened** pins and bushings.
- **Heavy duty hydraulic cylinders** with built in check valves, and protective hose guarding for more uptime.

Dimensions for Log Loading Grapples

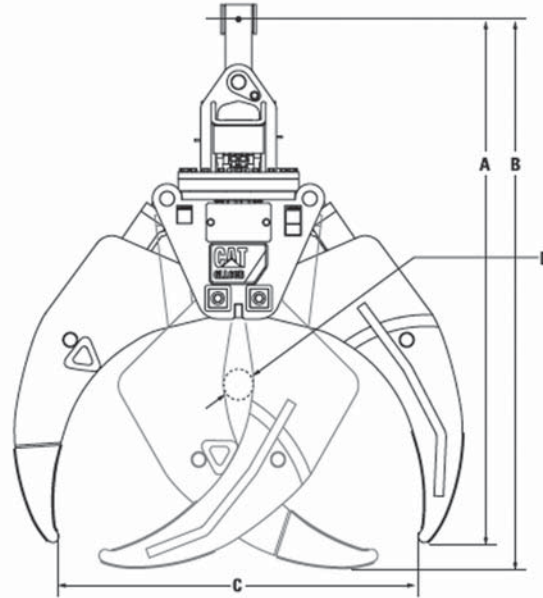

Part Number	GLL52B		GLL55B		GLL60B	
	271-1533		271-1534		271-1535	
Weight	1255 kg	2767 lb	1291 kg	2840 lb	1344 kg	2965 lb
Width	673 mm	26.5"	673 mm	26.5"	673 mm	26.5"
A Height, Open	2134 mm	84"	2184 mm	86"	2261 mm	89"
B Height, Closed	2159 mm	85"	2210 mm	87"	2286 mm	90"
C Maximum Opening	1321 mm	52"	1397 mm	55"	1524 mm	60"
D Minimum Opening	127 mm	5"	127 mm	5"	127 mm	5"
Rotation, Continuous	360°		360°		360°	
Rotation, Torque @ 8273 kPa (1200 psi)	1153 N·m	850 ft-lb	1153 N·m	850 lb-ft	1153 N·m	850 lb-ft

Features:

Loader Fork

- Few work tool lines can match the range and utility of Cat Forks. Forks transform loaders into high performance material handling platforms capable of sorting, stacking and working wherever product, palletized material or lumber is at hand.

Millyard and Logging Forks

- Cat Millyard and double top clamp forks are performance-matched to Cat Wheel Loaders for unmatched on-the-job performance. The design features of fork and loader complement each other to make the ideal total system solution for log handling applications. Both forks are ideally suited for heavy-duty applications: loading and unloading trucks, sorting, decking, and feeding the mill.

Log and Lumber Forks

- Handle logs or finished lumber with equal ease. The top clamp holds loose loads securely, and the pallet-style forks make short palletized material. This versatility makes them suitable for a wide range of jobs including loading trucks, decking and sorting lumber or logs.

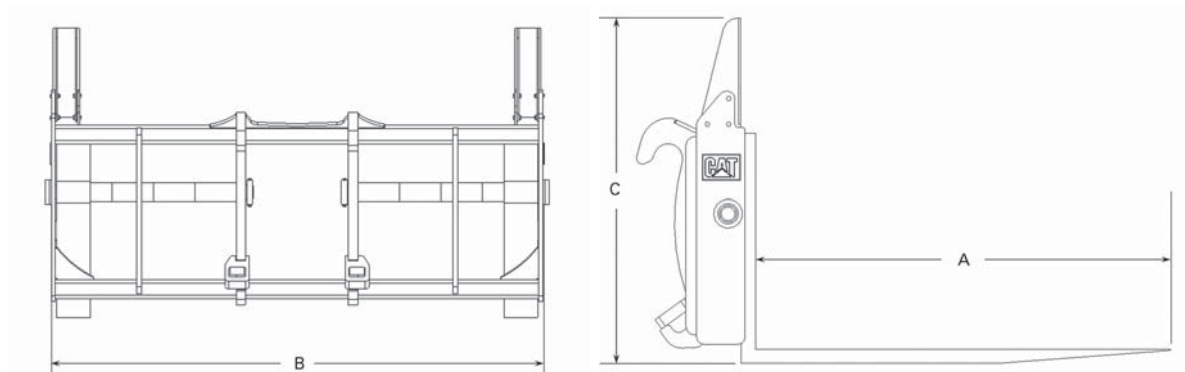

MODEL	924K/930K/938K	
Model	Log & Lumber Fork	
Group Number	399-0708	
Logging Arrangement	(Fusion Coupler)	
Linkage Arrangement		
A – Tine Length	1829 mm	6'0"
B – Overall Width	2591 mm	8'6"
C – Back Height	1526 mm	5'0"
Weight, Approximate	1181 kg	2604 lb

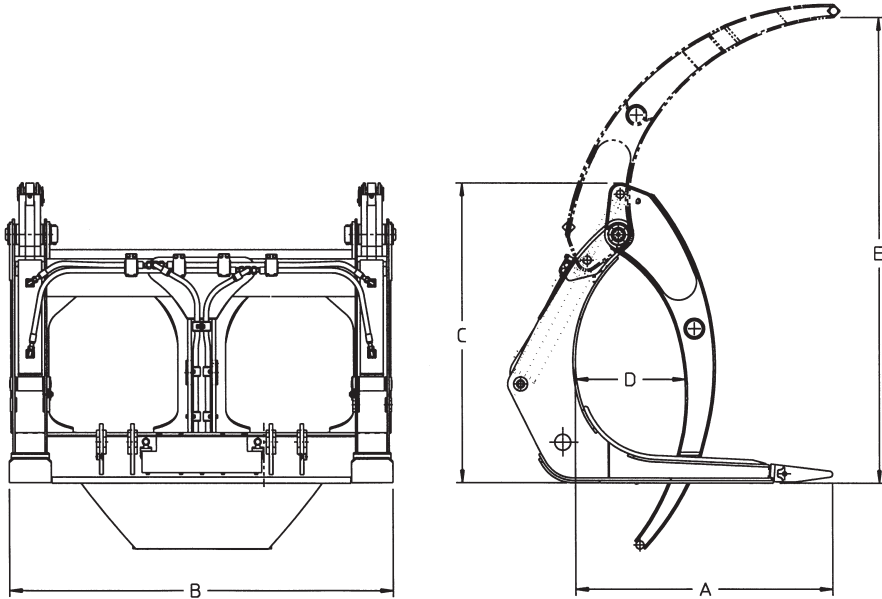

MODEL	924K/930K/938K	
Model	Millyard Fork	
Group Number	415-4023	
Logging Arrangement	415-4023	
Linkage Arrangement	(Fusion Coupler)	
A – Tine Length	1524 mm	60"
B – Overall Width	2204 mm	7'3"
C – Back Height	1492 mm	4'11"
D – Minimum Opening	487 mm	19.2"
E – Maximum Clamp Opening	2883 mm	9'6"
Weight, Approximate	2099 kg	4628 lb

MODEL	938H		950H/962H		950H/962H	
Model	Millyard Fork		Millyard Fork		Logging Fork	
Group Number	292-4050		256-7361		257-1959	
Logging Arrangement	292-4050		256-7361		257-1959	
Linkage Arrangement	(Pin-On)		(Pin-On)		(Pin-On)	
A – Tine Length	1372 mm	4'6"	1618 mm	5'4"	1626 mm	5'4"
B – Overall Width	2288 mm	7'6"	2724 mm	8'11"	2261 mm	7'5"
C – Back Height	1842 mm	6'1"	1919 mm	6'3"	1895 mm	6'2"
D – Minimum Opening	165 mm	6.5"	–	–	1535 mm	5'0"
E – Maximum Clamp Opening	2794 mm	9'2"	–	–	2520 mm	8'4"
Weight, Approximate	1677 kg	3697 lb	2515 kg	5545 lb	2200 kg	4860 lb

NOTE: Third valve required. Counterweight recommended.
Logging forks with millyard style clamps are available where logging application requires clamp to close between tines.

The 950H and 962H are not available in all regions. Contact your local Cat dealer for product availability.

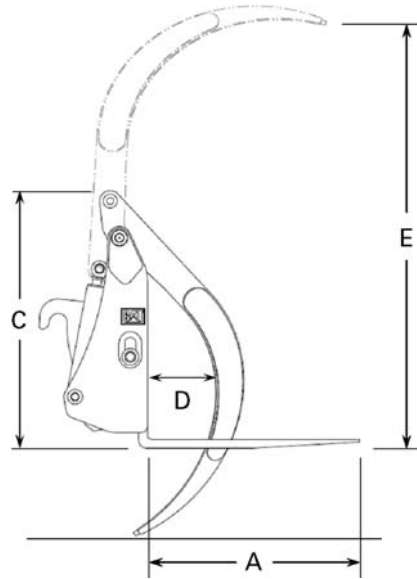
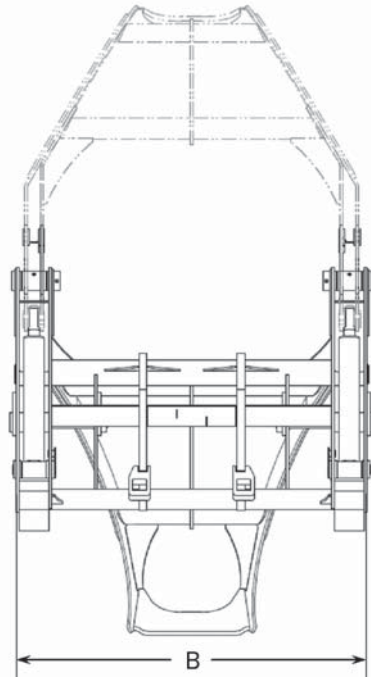

MODEL	924K/930K/938K	
Model	Millyard Pole Fork	
Group Number	396-1370	
Logging Arrangement	(Fusion Coupler)	
Linkage Arrangement		
A – Tine Length	1371 mm	54"
B – Overall Width	2264 mm	7'5"
C – Back Height	1629 mm	5'4"
D – Minimum Opening	166 mm	6'5"
E – Maximum Clamp Opening	2707 mm	8'11"
Weight, Approximate	1720 kg	3790 lb

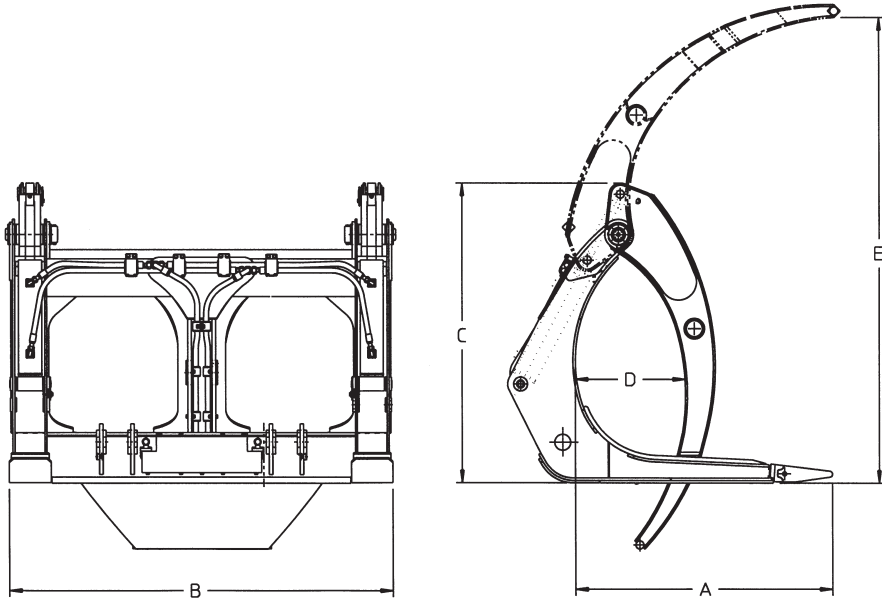

MODEL	950H/962H		966H	
Model	Logging Fork		Millyard	
Group Number				
Logging Arrangement	257-1960		253-7320	
Linkage Arrangement	(Coupler)		—	
A – Tine Length	1626 mm	5'4"	1618 mm	5'4"
B – Overall Width	2261 mm	7'5"	2416 mm	7'11"
C – Back Height	1895 mm	6'2"	1905 mm	6'3"
D – Minimum Opening	1535 mm	5'0"	697 mm	2'3"
E – Maximum Clamp Opening	2520 mm	8'4"	2927 mm	9'7"
Weight, Approximate	2200 kg	4860 lb	2681 kg	5911 lb

MODEL	966H		966H	
Model	Logging		Log and Lumber W/TC	
Group Number				
Logging Arrangement	255-7333		143-7209	
A – Tine Length	1618 mm	5'4"	1524 mm	5'0"
B – Overall Width	2416 mm	7'11"	2502 mm	8'3"
C – Back Height	1897 mm	6'3"	1726 mm	5'8"
D – Minimum Opening	1603 mm	5'3"	1506 mm	4'11"
E – Maximum Clamp Opening	2563 mm	8'5"	2794 mm	9'2"
Weight, Approximate	2300 kg	5065 lb	1585 kg	3491 lb

NOTE: Third valve required. Counterweight recommended.

Logging forks with millyard style clamps are available where logging application requires clamp to close between tines.

The 950H, 962H and 966H are not available in all regions. Contact your local Cat dealer for product availability.

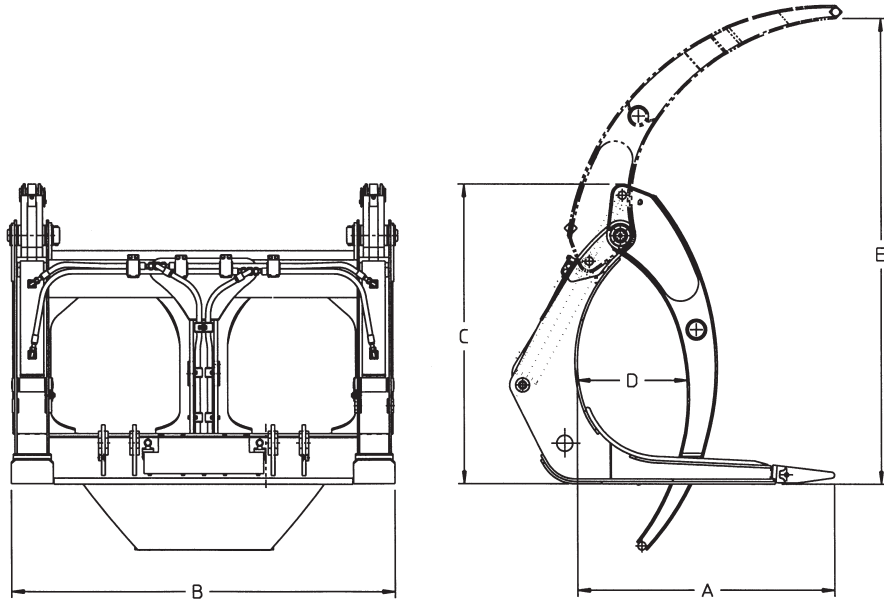

MODEL	980H	980H	950K	962K
Model	Double Top Clamp	Millyard Fork	Unloading Grapple Fork	Unloading Grapple Fork
Group Number				
Logging Arrangement	190-3982	192-7656	377-0722	352-7339
A – Tine Length	1829 mm 6'0"	1830 mm 6'0"	762 mm 2'6"	917 mm 3'0"
B – Overall Width	2756 mm 9'2"	2880 mm 9'5"	1832 mm 6'0"	1850 mm 6'1"
C – Back Height	1556 mm 5'1"	—	—	—
D – Minimum Opening	1828 mm 5'11.95"	694 mm 2'3"	1336 mm 4'5"	1450 mm 4'9"
E – Maximum Clamp Opening	2990 mm 9'9"	3073 mm 10'1"	2785 mm 9'2"	3123 mm 10'3"
Weight, Approximate	3175 kg 7000 lb	3262 kg 7191 lb	1929 kg 4253 lb	2144 kg 4727 lb

MODEL	966K	980K	988K	988K
Model	Millyard Fork	Millyard Fork	Double Top Clamp	Millyard Top Clamp
Group Number				
Logging Arrangement	253-7320	384-7540	210-9208	273-3209
A – Tine Length	1618 mm 5'4"	1829 mm 6'0"	2509 mm 8'3"	2508 mm 8'2"
B – Overall Width	2419 mm 8'0"	2761 mm 9'1"	2774 mm 9'1"	2870 mm 9'5"
C – Back Height	—	—	2783 mm 9'2"	—
D – Minimum Opening	656 mm 2'2"	582 mm 1'11"	—	998 mm 3'3"
E – Maximum Clamp Opening	2923 mm 9'7"	2951 mm 9'8"	3997 mm 13'1"	3911 mm 12'9"
Weight, Approximate	2683 kg 5913 lb	3958 kg 8726 lb	6696 kg 14,760 lb	7428 kg 16,376 lb

NOTE: Third valve required. Counterweight recommended.
Logging forks with millyard style clamps are available where logging application requires clamp to close between tines.

The 980H is not available in all regions. Contact your local Cat dealer for product availability.

Features — Couplers

Fusion Couplers

- Fusion Quick Couplers provide unmatched versatility to any loader. Change tools in seconds without leaving the cab. Any work tool backed by coupler hooks can be picked up; allowing the loader to fit whatever application is at hand.

Center-Lock™ Pin Grabber Couplers

- The Cat Center-Lock Pin Grabber Coupler allows buckets and other standard work tools to be used without any modification. Exchanging work tools in seconds improves overall production and increases machine versatility. The Coupler is pinned on in place of the bucket with standard pins, and can be easily removed should the need arise to mount a tool directly to the stick.
- The Center-Lock Coupler offers new possibilities. Buckets can be turned around and used in front shovel mode for final trench clean up. An integral lift eye on the coupler body allows lifting without the weight of the bucket, increasing both machine capacity and visibility from the cab.

Features — Buckets and Thumbs

Cat Bucket Thumbs for Hydraulic Excavators

- Multiply the performance of a Cat Excavator by adding a Cat Bucket Thumb. This highly versatile work tool acts in conjunction with the bucket to allow the excavator to grab irregularly shaped items and load loose materials and debris.

Mini Bucket Thumbs

- Cat Bucket Thumbs are matched to Hydraulic Excavator Buckets for increased on-the-job performance. A thumb works with the bucket to grab, pick and sort debris, brush, trash and rock, opening up new production opportunities for your Cat Mini Excavator. Thumbs are an ideal complement to excavators working in demolition, land clearing, landscaping, material handling and construction jobs.

Clamshell Buckets

- Cat Clamshell Buckets are the premier tools for cleanup, demolition, ground clearing and forestry work. Built of heavy T1 steel, these buckets are tough and durable for long service life in the most difficult applications. Clamshell buckets feature continuous 360° rotation, powered by a high-torque hydraulic motor.

Features:**Buckets, U-blades, Bowldozers, Chip Scoops**

- The high-capacity, high-efficiency design of these tools makes them high-production workhorses. They are matched to specific machines and material densities for optimum performance. The extra capacity and load retention capabilities ensure maximum usage and productivity.

WHEEL TRACTOR MODEL	824H		834H	
Blade:				
Capacity	24 m ³	31.4 yd³	29.8 m ³	39 yd³
Length (cutting width)	4.78 m	15'7"	6.09 m	20'0"
Height	2.24 m	7'4"	2.24 m	7'4"
Wing angle		30°		30°
Weight, Installed (without hydraulics)				
BD (S) Dozer	3630 kg	8000 lb	4627 kg	9470 lb

WHEEL TRACTOR MODEL	814F Series II		824H		834H	
Chip Scoop:						
Lift and Carrying Capacity	15.3 m ³	20 yd³	20.6 m ³	27 yd³	34.4 m ³	39.5 yd³
Dozing Capacity	30.4 m ³	40 yd³	41.3 m ³	54 yd³	49.4 m ³	65 yd³
Width	3.73 m	12'3"	4.03 m	13'3"	4.83 m	15'10"
Height	2.29 m	7'6"	2.79 m	9'2"	2.25 m	7'4"
Depth	2.46 m	8'1"	2.95 m	9'8"	3.02 m	9'11"
Weight	5390 kg	11,880 lb	11 420 kg	19,125 lb	11 105 kg	24,480 lb

NOTE: For specifications of Woodchip Dozers used on track-type tractors, see the Bulldozer section in this handbook.

Features — Rakes

Loader, Clearing and Clamp and Blade Rakes

- Rakes are durable, high-capacity tools that will increase production for land clearing, site cleanup and site preparation. Available in quick coupler and pin-on models, rakes pile brush, stack and carry debris and load trucks. Features include thick, fabricated teeth, a heavy-duty push bar and serrated tree pusher. A high brush rack retains the load, prevents back spillage and increases carrying capacity.

USE OF LOG VOLUME TABLES

The tabulated volumes on these pages were calculated with no taper in log diameter from base to top. Therefore each value listed in the table represents the volume of a true cylinder. In practice this may occur only in short sections of large diameter trees. To obtain the volume of solid wood logs, excluding bark:

1. Establish the base diameter of the log inside the bark and above the butt flare (extreme end taper).
2. Repeat the procedure for the top (small end) of log.
3. Enter log volume table at each of the two established diameters. Move horizontally to the vertical column closest to the length of the log being measured.
4. Establish the volume figures for each end of the log, add the two together and divide by two to obtain average log volume.

METRIC LOG VOLUMES (in Cubic Meters)

Log Diameter (cm)	LOG LENGTH (METERS)														
	2	4	6	8	10	12	14	16	18	20	22	24	26	28	30
10	0.016	0.031	0.047	0.063	0.078	0.094	0.12	0.13	0.14	0.16	0.17	0.19	0.20	0.22	0.24
15	0.035	0.071	0.11	0.14	0.18	0.21	0.25	0.28	0.32	0.35	0.39	0.42	0.46	0.49	0.53
20	0.06	0.13	0.19	0.25	0.31	0.38	0.44	0.50	0.57	0.63	0.69	0.75	0.82	0.86	0.94
25	0.10	0.20	0.30	0.39	0.49	0.59	0.69	0.79	0.88	0.98	1.08	1.18	1.28	1.37	1.47
30	0.14	0.28	0.42	0.57	0.71	0.85	0.99	1.13	1.27	1.42	1.56	1.70	1.84	1.98	2.12
35	0.19	0.38	0.58	0.7	0.96	1.15	1.35	1.54	1.73	1.93	2.12	2.31	2.50	2.69	2.89
40	0.25	0.50	0.75	1.01	1.26	1.51	1.77	2.02	2.27	2.52	2.78	3.02	3.27	3.51	3.77
45	0.32	0.64	0.95	1.27	1.59	1.91	2.22	2.54	2.86	3.18	3.50	3.82	4.13	4.45	4.77
50	0.39	0.79	1.18	1.57	1.96	2.36	2.76	3.16	3.54	3.94	4.34	4.71	5.10	5.49	5.89
55	0.48	0.95	1.43	1.90	2.38	2.85	3.33	3.80	4.28	4.75	5.23	5.70	6.18	6.65	7.12
60	0.57	1.13	1.70	2.26	2.83	3.39	3.96	4.52	5.09	5.65	6.22	6.78	7.35	7.92	8.48
65	0.66	1.33	1.99	2.65	3.32	3.98	4.65	5.31	5.98	6.64	7.30	7.96	8.62	9.29	9.95
70	0.77	1.54	2.31	3.08	3.85	4.62	5.40	6.15	6.93	7.70	8.48	9.23	10.0	10.77	11.54
75	0.88	1.77	2.65	3.53	4.42	5.30	6.19	7.06	7.95	8.84	9.72	10.60	11.49	12.37	13.25
80	1.01	2.01	3.02	4.02	5.03	6.03	7.05	8.06	9.07	10.08	11.09	12.10	13.10	14.10	15.10
85	1.13	2.27	3.40	4.54	5.67	6.81	7.94	9.08	10.20	11.32	12.47	13.62	14.75	15.89	17.02
90	1.27	2.54	3.82	5.09	6.36	7.63	8.90	10.17	11.43	12.71	13.99	15.27	16.54	17.81	19.10
95	1.42	2.84	4.26	5.67	7.09	8.51	9.92	11.33	12.76	14.18	15.60	17.01	18.43	19.85	21.26
100	1.57	3.14	4.71	6.28	7.85	9.42	11.0	12.58	14.16	15.72	17.30	18.85	20.42	22.0	23.56
125	2.45	4.90	7.36	9.82	12.27	14.73	17.18	19.6	22.1	24.5	27.0	29.5	32.0	34.4	36.8
150	3.53	7.1	10.6	14.1	17.7	21.2	24.7	28.3	31.8	35.3	38.8	42.4	45.9	49.5	53.0
175	4.8	9.6	14.5	19.2	24.0	28.9	33.7	38.5	43.3	48.1	53.0	57.7	62.6	67.3	72.2
200	6.3	12.6	18.8	25.1	31.4	37.7	44.0	50.3	56.5	62.8	69.1	75.4	81.7	88.0	94.2

ENGLISH MEASURE LOG VOLUMES (in Cubic Feet)

Log Diameter (inches)	LOG LENGTH (FEET)																	
	8	12	16	20	24	28	32	36	40	44	48	52	56	60	70	80	90	100
4	0.7	1	1.4	1.7	2.1	2.4	2.8	3.1	3.5	3.8	4.2	4.5	4.9	5.2	6.1	7	7.8	8.7
6	1.6	2.4	3.1	3.9	4.7	5.5	6.3	7.1	7.8	8.6	9.4	10	11	12	13	16	18	20
8	2.8	4.2	5.6	7	8.4	9.8	11	13	14	15	17	18	19	21	24	28	31	35
10	4.4	6.5	8.7	11	13	15	17	20	22	24	26	28	31	33	38	44	49	55
12	6.3	9.4	13	16	19	22	25	28	31	35	38	41	44	47	55	63	71	79
14	8.5	13	17	21	26	30	34	39	43	47	51	56	60	64	74	86	96	101
16	11	17	22	28	34	39	45	50	56	61	67	73	78	84	98	112	126	140
18	14	21	28	35	42	49	57	64	71	78	85	92	99	106	124	141	159	177
20	17	26	35	44	52	61	70	79	87	96	105	113	122	131	153	175	196	218
22	21	32	42	53	63	74	85	95	106	116	127	137	148	158	185	211	238	264
24	25	38	50	63	75	88	101	113	126	138	151	163	176	189	220	251	283	314
26	29	44	59	74	89	103	118	133	147	162	177	192	207	221	258	295	332	369
28	34	51	68	86	103	120	137	154	171	188	205	222	240	256	299	342	385	428
30	39	59	79	98	118	137	157	177	196	216	236	255	275	295	344	393	442	491
32	45	67	89	118	134	156	179	201	223	246	268	290	313	335	391	447	503	559
34	50	76	101	126	151	177	202	227	252	277	303	328	353	378	441	504	567	631
36	57	85	113	141	170	198	226	255	282	311	339	368	396	424	495	566	637	707
38	63	95	126	158	189	220	252	284	315	347	378	410	441	473	551	630	709	788
40	70	105	140	175	210	244	279	314	349	384	419	454	489	524	611	698	785	873
50	109	164	218	273	327	382	436	491	545	600	645	709	764	818	955	1091	1227	1364
60	157	234	314	393	471	550	628	707	785	864	943	1021	1100	1178	1374	1571	1767	1964
70	214	321	428	535	642	748	855	962	1069	1176	1283	1389	1497	1604	1871	2138	2405	2673
80	279	420	559	698	838	977	1117	1257	1396	1536	1676	1815	1955	2095	2441	2293	3142	3491

WEIGHTS OF COMMERCIALY IMPORTANT WOODS

Species	kg/m ³ (Green)	lb/ft ³ (Green)	Species	kg/m ³ (Green)	lb/ft ³ (Green)
A. Temperate Zone*			Maple, Big Leaf	753	47
Alder, Red	737	46	Black	865	54
Ash, White	769	48	Red	801	50
Aspen	689	43	Silver	721	45
Baldcypress	817	51	Sugar	897	56
Basswood	673	42	Oak, Black	1009	63
Beech	865	54	Chestnut	977	61
Birch, Paper	801	50	Red	1009	63
Yellow	929	58	Red, Swamp	1073	67
Cedar, Alaska	577	36	Swamp Chestnut	1041	65
Incense	721	45	White	993	62
Northern, White	449	28	White, Swamp	1105	69
Port-Orford	897	56	Pine, Jack	801	50
Western Red	433	27	Loblolly	993	62
Cherry, Black	721	45	Lodgepole	625	39
Cottonwood, Eastern	785	49	Long Leaf	993	62
Douglas Fir, (Coast)	881	55	Norway (Red)	673	42
(Inland Empire)	577	36	Short Leaf	993	62
Elm, American	865	54	Slash	993	62
Fir, Alpine	449	28	Sugar	817	51
Balsam	721	45	Western Yellow, (Ponderosa)	721	45
Nobel	481	30	White (Western)	561	35
Red	769	48	White (Eastern)	577	36
Silver	577	36	Poplar, Yellow	609	38
White	753	47	Redwood	801	50
Gum, Black	721	45	Spruce, Black	513	32
Blue	1121	70	Engleman	625	39
Red	801	50	Red	545	34
Tupelo	897	56	Sitka	529	33
Hemlock, Eastern	801	50	White	545	34
Western	961	60	Sweetgum	801	50
Hickory, Pecan	993	62	Sycamore	833	52
True	1009	62	Tamarack	753	47
Larch, Western	769	48	Walnut, Black	929	58
Locust, Black	929	58	Willow, Black	801	50
Magnolia, Cucumber	785	49			

*NOTE: Weights taken from U.S. Dept. of Agriculture handbook No. 72, Wood Handbook.

- Southeast Asia
- West Africa

Species	kg/m ³ (Green)	lb/ft ³ (Green)
B. Southeast Asia		
Apitong	961	60
Bintangor	865	54
Chumprak	929	58
Ebony	1746	109
Geronggang	721	45
Jelutong	641	40
Kapur (Borneo Camphorwood)	1073	67
Keruing	1121	70
Krabak	817	51
Kruen	1121	70
Lumbayau	929	58
Mahogany, Philippine		
(Red Luan)	753	47
(White Luan)	769	48
(Yellow Luan)	769	48
Mahoni	913	57
Alayan Kauri (Damar Minyak)	817	51
Melantai	705	44
Melapi	849	53
Mangkulang	929	58
Meranti Bakau	849	53
Meranti, Dark Red	753	47
White	769	48
Yellow	769	48
Mersawa	817	51
Nyatoh	897	56
Palosapis	817	51
Pulai	545	34
Ramin	1073	67
Rosewood (Sonokelina)	1314	82
Seraya, Dark Red	753	47
Yellow	769	48
White	769	48
Teak	1073	67

Species	kg/m ³ (Green)	lb/ft ³ (Green)
C. West Africa		
Abura	850	53.06
Ako	800	49.94
Azobe	1300	81.16
Aniegre (Mukali)	950	59.31
Bete	900	56.19
Bosse	900	56.19
Bubinga	1000	62.43
Dibetau	750	46.82
Douka (Makore)	950	59.31
Doussie	1200	74.91
Framire	850	53.06
Fromager	550	34.34
Iloba	750	46.82
Iroko	1200	74.91
Kokrodua (Afromosia)	1000	62.43
Kosipo	900	56.19
Limba	750	46.82
Mahogany	750	46.82
Moabi	1100	68.67
Niangon	900	56.19
Okoume	650	40.57
Ozigo	900	56.19
Padouk	1000	62.43
Samba (Obeche)	650	40.58
Sapelli	900	56.19
Sipo	800	49.94
Tchitola	850	53.06
Tiaba	900	56.19
Tola	850	53.06

Weights of Commercially Important Woods

- Australia
- New Zealand
- Papua New Guinea

Forest Products Tables

Species	kg/m ³ (Green)	lb/ft ³ (Green)
D. Australia		
Ash Alpine	1041	65
Mountain	1009	63
Silvertop	1330	83
Black Butt	1121	70
Box Long Leaf	993	62
Yellow	1105	69
Black	1105	69
Brownbarrel	1073	67
Candle Bark	657	41
Gum Grey	1217	76
Manna	1121	70
Mountain	1169	73
Mountain Grey	1057	66
River Red	1137	71
Forest Red	1201	75
Southern Blue	1217	76
Spotted	1201	75
Sydney Blue	1153	72
Iron Bark Gray	1330	83
Narrowleaved	1330	83
Red	1330	83
Jarrah	1169	73
Karri	1169	73
Mahogany Red	1153	72
White	1282	80
Myrtle	1169	73
Peppermint	1120	70
Pine Radiata	865	54
Monerey	865	54
Celerytop	1057	66
Stringy Bark Brown	1233	77
Messmate	1169	73
Yellow	1217	76
White	1121	70
Tallowwood	1201	75
Wandoo	1282	80

Species	kg/m ³ (Green)	lb/ft ³ (Green)
E. New Zealand		
Exotic Softwoods		
Radiata Pine	1000	62
Douglas Fir	734	45
Corsican Pine	985	61
Redwood	1016	63
Larch	960	60
Indigenous Softwoods		
Mati	1120	70
Rimu	1130	70
Exotic Hardwoods		
Eucaliptus Botryoides	893	56
Eucaliptus Saligna	1200	75
Indigenous Hardwoods		
Beech — Silver	920	57
Beech — Red	1200	75
Tawa	1022	64

Species	kg/m ³ (Green)	lb/ft ³ (Green)
F. Papua New Guinea		
Pine, Hoop	520	32
Kauri	480	30
Klinki	510	31
Kwila	800	50
Erima	390	24
Taun	680	42
Walnut, PNG	560	35
Cedar, Pencil	720	50
Mersawa	650	40
Celtis, Hard	780	48
Rosewood, PNG	600	37
Beech, PNG	830	51
Oak, PNG	650	40
Ebony, PNG Black	1115	69
PNG White	720	50
Hardwood, Yellow	780	48
Hopea, Heavy	960	60
Light	710	44
Podocarp, Black	410	25
Terminalia, Brown	450	28

ESTIMATING NUMBER OF TREES PER HECTARE

Spacing (Meters)	Spacing (Meters)							
	1	2	3	4	5	6	7	8
1	10 000	5000	3333	2500	2000	1667	1428	1250
2	5000	2500	1667	1250	1000	834	714	625
3	3333	1667	1111	834	667	556	477	417
4	2500	1250	834	625	500	417	357	313
5	2000	1000	667	500	400	330	286	250
6	1667	834	556	417	333	278	238	208
7	1428	714	477	357	286	238	204	179
8	1250	625	417	313	250	208	179	156

ESTIMATING NUMBER OF TREES PER ACRE

Spacing (Feet)	Spacing (Feet)							
	5	6	7	8	9	10	11	12
5	1742	1452	1244	1089	968	871	792	726
6	1452	1210	1037	907	806	726	660	605
7	1244	1037	888	777	691	622	565	518
8	1089	907	777	680	605	544	495	453
9	968	806	691	605	537	484	440	403
10	871	726	622	544	484	435	396	363
11	792	660	565	495	440	396	360	330
12	726	605	518	453	403	363	330	302
13	671	558	478	418	372	335	304	279
14	622	518	444	390	346	311	283	259
15	580	484	415	363	323	290	264	242

COMPARISON OF LOG RULES ● Board Foot Values for 16-Foot Logs

Diameter at Small End, Inside Bark, Inches	International 1/4 Inch	Scribner	Scribner Decimal	Spaulding	Doyle
4	5	10	10	—	—
6	20	18	20	—	4
8	40	32	30	—	16
10	65	54	60	50	36
12	95	79	80	77	64
14	135	114	110	114	100
16	180	159	160	161	144
18	230	213	210	216	196
20	290	280	280	276	256
22	355	334	330	341	324
24	425	404	400	412	400
26	500	500	500	488	484
28	585	582	580	569	576
30	675	657	660	656	676
32	770	736	740	748	784
34	875	800	800	845	900
36	980	923	920	950	1024
38	1095	1068	1070	1064	1156
40	1220	1204	1200	1185	1296

UNIT OF MEASUREMENT DEFINITIONS

1 board foot	= 1/12 ft ³ of solid wood (1' × 1' × 1")
1000 board feet	= 83.33 ft ³ of solid wood
1 c. unit of wood	= 100 solid ft ³ = 1200 board feet = 2.83 ³
1 cord of wood	= 128 ft ³ of stacked logs = 3.62 m ³
1 unit of wood	= 200 ft ³ of loose chips = 5.66 m ³
1 cord of wood	= 0.85 units
1 Hoppus Ton	= 50 ft ³ (assumed) = 63.65 ft ³ (actual) = 600 board feet = 763.8 BF Brereton = 1.8 m ³ actual = 1.4 m ³ assumed
1 cubic meter	= 35.32 ft ³ = 424 board feet = 333 board feet Hoppus tons = 0.555 Hoppus Tons
1 MBF Brereton	= 2.36 m ³ = 785.4 board feet Hoppus
1 MBF Hoppus	= 1273 board feet-Brereton
MBF	= Thousand board feet
1 Super Foot	= 1 board foot
100 Super Feet	= 1000 board foot = 0.236 m ³
600 Super Feet	= 50 ft ³
1 lb/ft ³	= 16.0185 kg/m ³

CUBIC FEET OF SOLID WOOD PER CORD

Length of Sticks-Ft.	Diameter at Small End		
	1"-2.5"	2.5"-5.5"	Over 5.5"
2	65	84	91
4	64	82	89
8	59	77	84
12	54	71	78

RULE OF THUMB CONVERSIONS

1 c. unit of wood = 1.117 cords = 1.25 units of chips = 250 ft ³ of chips = 7.08 m ³
1 cord of wood = 85 ft ³ of solid wood = 1.06 units of chips = 2.41 m ³
1 unit of chips = 80 ft ³ of solid wood = 2.27 m ³
1 cord of wood = 500 board feet = 1.18 m ³
2000 pounds of chips = 500 pounds of pulp
1 cord = 212 ft ³ of chips = 6 m ³

HIGHWALL MINING SYSTEM

CONTENTS

HW300

Product Line Description	6-1
Features	6-1
Highwall Mining Method	6-2
Highwall Miner Applications	6-2
Cutter Module	6-3
Power Head	6-3
Mobility	6-3
Operator Comfort	6-3
Push Beams	6-4
Reel and Chain	6-4
Control System	6-4
Anchoring System	6-4
Equipment Relocation	6-5
Safety	6-5
Support	6-5
Specifications	6-6
Dimensions	6-9
Optional Equipment	6-10



PRODUCT LINE DESCRIPTION

Linking underground and surface mining operations, the Cat® Highwall Mining System is a low cost solution for mining coal. The HW300 offers a safe and innovative method for extracting coal from exposed seams in a multitude of applications.

HW300 FEATURES

- **Maximum Extraction** — Low cost coal to traditional mining methods.
- **Safe Operation** — The entire mining cycle is completed by a three- or four-man crew, with no personnel going underground at any time.
- **Excellent Mobility** — The highwall miner trams easily from entry to entry and discharges coal in tight spaces.
- **Operator Comfort** — The air-conditioned cab offers an ergonomic workplace where all controls are within the operator's reach.
- **Easy Equipment Relocation** — The highwall mining system can be taken apart in modules — sized for transport using regular public roads.
- **Cutter Module Choices** — Caterpillar offers four different cutter modules for the Highwall Miner: extra low seam, low seam, mid seam and high seam.

HIGHWALL MINING METHOD

Feasibility Determination

Highwall mining can produce exceptionally low cost coal if conditions are right. Having the right geology and environmental conditions is the key to success. Caterpillar and its dealers can assist you with an in depth evaluation of the site. For a very high-level evaluation, you can start by going to the Highwall Miner page on www.cat.com and use the on-line site evaluation tool.

Extracting Coal Affordably and Safely

Highwall mining is a proven and versatile primary method for mining coal from exposed seams.

The Cat HW300 highwall miner stands on the pit floor or on a bench, directly in front of the exposed seam and makes long parallel rectangular drives into the coal seam. Pillars of material are left in place between the entries to support the over burden.

A remote-operated cutter module is pushed into the seam by a string of push beams (unmanned coal-conveying elements) that transport the mined coal back to the entry of the drive onto a stockpile. The whole mining cycle is completed by a three- or four-man crew, with no personnel going underground at any time.

The self-contained and self propelled Cat highwall mining system offers an innovative method for extracting coal from exposed seams in a multitude of applications.

Whether you're operating a trench, open cast or contour mine, the Cat highwall mining system can extract coal affordably and safely:

- **Open Cast** — Highwall mining is used to mine coal from underneath the final highwall, when the strip limit is reached due to economic reasons or surface conditions.
- **Trench Mining** — The unit mines coal from both sides of a purpose-prepared trench; this mining method is used when an open pit is not an option.
- **Contour Mining** — In a mountainous area, the Cat highwall mining system can follow a coal seam along the side of the hill.

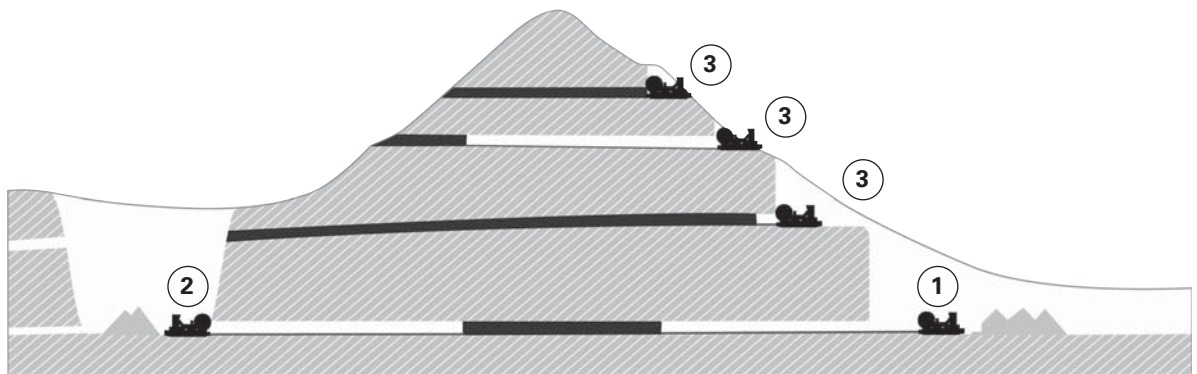

HIGHWALL MINER APPLICATIONS

- ① **Open Cast Pit Mining**
- ② **Trench Mining (mining seams on both sides)**
- ③ **Contour Mining**

CUTTER MODULE

Proven Cutter Module

Caterpillar offers four separate cutter modules for the HW300: extra low seam, low seam, mid seam and high seam.

Recommended Seam Heights

Extra Low Seam	711 mm	28 in
Low Seam	762 mm	30 in
Mid Seam	1200 mm	47.2 in
High Seam	2400 mm	94.5 in

The cutter modules are interchangeable and quickly attach to the power head assembly. The cutting cycle is fully automated, yet allows the operator to manually adjust the machine function using an ampere reading as the coal seam varies. This proven technology allows the cutter module to accurately follow the coal seam and produce a cleaner product.

Advanced Technology

An optional Gamma Detection system can be used to guide the cutter module through the coal seam, leaving predetermined amounts of coal in the roof and floor. This system also allows the mining of coal in soft roof and/or soft floor situations.

For even more accurate directional mining operation, Caterpillar offers an optional solid-state, fiber-optic, gyro-based navigation and steering system. This provides operators with very precise cutter module location data in real time for enhanced cutter module steering and pillar width control.

POWER HEAD

Heavy Duty Power Head Assembly

The power head drives the cutter module and push beam string forward using two hydraulically-powered sump cylinders with a 6.86 m (22.5 ft) stroke.

The pushing force of 133 tonnes (147 tons) propels the cutter module to a depth of 300 m (1000 ft) and the pulling force of 275 tonnes (303 tons) retracts it safely.

MOBILITY

Improved Maneuverability in Tight Spaces

The Cat highwall mining system is an agile, self-propelled machine that operates on contour benches as narrow as 18 m (59 ft). It trams easily from entry to entry and discharges coal in tight spaces. An optional right-angle conveyor system discharges coal on the right or left side on narrow benches. It can also discharge onto a stacking conveyor system, where coal is moved to the center of the bench for stockpiling large volumes.

Four heavy-duty, hydraulically-powered tracks articulate independently in two operating modes — mine mode and tram mode — and can rotate the machine 360°, which improves maneuverability in congested areas. Mine mode is used for moving parallel to the highwall, while tram mode is used when moving from pit to pit.

OPERATOR COMFORT

Ergonomic Design for Comfort, Control and Productivity

The Cat highwall mining system is equipped with a comfortable, climate controlled, pressurized cab that offers a full view of the mining operation and the highwall. The full suspension operator seat and the two user-friendly touchscreens create an ergonomic workplace, placing controls and system information at the operator's fingertips.

PUSH BEAMS

Backbone of the Highwall Mining System

Cat push beams are 6 m (20 ft) long, rectangular, reinforced steel box structures joined together to form a string, which connects the highwall mining system to the cutter module.

The push beam string is the backbone of the machine; pushing and pulling the cutter module in and out of the coal seam.

The push beam conveys mined coal inside. The enclosed beam protects the coal from contamination and supports the hose chain that supplies control and power to the cutter module.

Other Cat push beam advantages include:

- A strong method of attachment that is secured and disengaged quickly
- A push beam connection that allows the string and cutter module to navigate through coal seam rolls and undulations
- A simple design free of electrical and hydraulic connections
- Push beams that can be stacked six high reducing storage area in narrow work sites, even under tough pushing and pulling conditions.

REEL AND CHAIN

Storage and Protection of Cables and Hoses

A steel-armored hose chain stores and protects all electric power cables, hydraulic and coolant lines, and the control cable to the cutter module. The hose chain is automatically unrolled and retracted on a reel during mining.

CONTROL SYSTEM

Control System with Diagnostics

The Cat highwall mining system's operation is controlled by a Programmable Logic Controller, which provides reliable performance for greater uptime. A comprehensive diagnostics system, including troubleshooting assistance, streamlines maintenance procedures.

ANCHORING SYSTEM

Maximum Stabilization even under Toughest Conditions

Two drills mounted on the front of the machine are used to drill into the pit floor up to 2.4 m (8 ft). High-strength pins are then inserted through the base frame into the pit floor to help stabilize the machine and to maintain its accurate position, even under tough pushing and pulling conditions.

EQUIPMENT RELOCATION

Convenient Modularity for Quick Assembly

For quick relocation over long distances, the Cat highwall mining system can be taken apart in modules. Rapid disassembly and reassembly is facilitated by convenient hydraulic and electrical connectors, and all modules are sized for transport using regular public roads.

Depending on local conditions, the system can also be transported between sites and without disassembly by heavy haul trucks.

SAFETY

Designed with Safety as the First Priority

The Cat highwall mining system is engineered and equipped with a priority on safe operation; safety features include:

- **Elevated Cab with Cameras** — For a complete view of the highwall mining system and mining operation, the cab is elevated on the machine and three magnetic base cameras are provided whose positions can be easily and quickly adjusted.
- **Above-ground Operation** — Operation of the system is performed entirely on the surface with no crew members working underground.
- **Small-crew Size** — The highwall mining system only requires a three- to four-person crew for full operation.
- **Remote Operation** — In an emergency, the machine can be operated remotely using a laptop from as far away as 61 m (200 ft).
- **Anchoring System** — Two drills mounted on the front of the machine are used to drill into the pit floor up to 2.4 m (8 ft). High-strength pins are then inserted through the base frame into the pit floor to help stabilize the machine and to maintain its accurate position, even under tough pushing and pulling conditions.

SUPPORT

Product Support

Every HW300 is backed by 24/7 support from highly skilled and experienced staff. Large warehouse stocks with spare parts ensure the highest levels of machine uptime, and service and parts back-up can be tailored to your needs.

Training

Caterpillar can arrange operational and technical training which covers every aspect of the HW300 Highwall Miner.

Support Equipment

The highwall miner has the following support equipment needs:

1. Two wheel loaders; one to load push beams during mining, one to manage the coal stock pile.
2. A stacker belt is recommended for managing the coal as it comes off the machine.
3. Equipment requirements for keeping the seam exposed will depend on the application.

HW300 HIGHWALL MINING SYSTEM SPECIFICATIONS

Environmental and Operational Conditions

The Cat HW300 is designed for the following environmental and operating conditions:

Mine Application	<ul style="list-style-type: none"> • Trench Application • Open Pit Mining • Contour Mining
Ambient Temperature	<ul style="list-style-type: none"> • -30° C to +35° C (-22° F to +95° F) • Arctic and Tropical Packages are optional
Pit Floor Gradient	• 8 degrees nominal in any direction, 10 degrees maximum in any direction for traveling
Maximum Seam Gradient	• 8 degrees down dip relative to horizontal (Level side-to-side, pit floor prepared at 3 degrees)

Power and Consumption

Electric Power (Installed) 995 VAC, 50/60 Hz Mid Seam Cutter Module Rear Discharge Machine

Function	Qty	Volts	Power (ea)		Total Power	
			kW	hp	kW	hp
Cutting Motors (Mid or High Seam)*	2	995	179	240	358	480
Gathering Motors (Mid to High Seam)	2	995	33.5	45	67	90
Horizontal Auger Motors	2	995	373	500	746	1000
Hydraulic Pump Motor	1	995	224	300	224	300
Base Frame Conveyor Motor	1	995	75	100	75	100
Right Angle Conveyor Motor	1	995	75	100	75	100
Stacking Conveyor Motor (Customer Equipment)	1	995	75	100	75	100
Cooling Fan Motors	6	480	1.5	2	9	12
Water Circulating Pump Motor	1	480	7	10	7	10
Hydraulic Oil Circulating Pump Motor	1	480	11	15	11	15
Water Spray Pump Motor	1	480	5.5	7.5	5.5	7.5
Air Compressor Motor	1	480	4	5	4	5
TOTAL					1656.5	2219.5

*The two cutting motors for the extra low seam and low seam cutter modules are rated at 123 kW (165 hp) each.

Power for the Miner

The miner can be powered from a utility grid or if being operated in remote areas, using a Cat generator set available from any Cat dealer.

Water Consumption

Water consumption for surface dust suppression during the mining operation is an average of 1000 L (264 gal) per hour (estimate).

HW300 HIGHWALL MINING SYSTEM SPECIFICATIONS

General Specifications

All dimensions and weights are approximate and depending on final specification.

Machine Dimensions while Mining	<ul style="list-style-type: none"> • Width: 11.7 m (38.5 ft) • Height: 8.7 m (28.7 ft) • Length: LPCM: 20.3 m (66.5 ft) Mid Seam CM: 21.3 m (70 ft)
Machine Dimensions while Tramming	<ul style="list-style-type: none"> • Width: 7.7 m (25.3 ft) Track Width • Height: 9.1 m (30 ft) • Length: LPCM: 20.3 m (66.5 ft) Mid Seam CM: 21.3 m (70 ft) • Minimum road width for overhanging structure: 9.2 m (30.1 ft) with right-angle conveyor removed.
Weight	<ul style="list-style-type: none"> • HWM without cutter head: 225 000 kg (495,665 lb) • Push Beam Weight: 5330 kg (11,750 lb) — 54 pieces (54 push beams are standard for a system)

6

Extra Low Seam Cutter Modules

The extra low seam cutter module is specifically designed to work with the Cat HW300

Cutter Drum Diameter	• 65 cm (25.5 in)
Cutting Width	• 294 cm (116 in)
Drum Drive	• (2) 123 kW (165 hp) /995 VAC/60 Hz Electric Motors
Maximum Cutting Height	• 154 cm (61 in)
(2) Hydraulic cylinders with integrated liner transducers to measure cutting height.	
Gathering System	• Coal gathered by augers

Low Seam Cutter Modules

The low profile cutter module is specifically designed to work with the Cat HW300

Cutter Drum Diameter	• 71.12 cm (28 in)
Cutting Width	• 2.95 m (116 in)
Drum Drive	• (2) 123 kW (165 hp) /995 VAC/60 Hz Electric Motors
Maximum Cutting Height	• 1.6 m (63 in)
(2) Hydraulic cylinders with integrated liner transducers to measure cutting height.	
Gathering System	• Coal gathered by augers

Mid Seam Cutter Modules

The mid cutter module is a Cat design that employs a CM235 Cutting Boom and gathering pan assembly.

Cutter Drum Diameter	• 965 mm (38 in)
Drum Width	• 3.5 m (11 ft 6 in)
Drum Drive	• (2) 175 kW (235 hp)/995 VAC/60 Hz
Gathering System	• CLA System

High Seam Cutter Modules

Cutter Drum Diameter	• 966 mm (38 in)
Cutting Width	• 3505 mm (138 in)
Minimum Recommended Seam Height	• 2400 mm (94.5 in)

Optional

Navigation and Steering	• An internal navigation device can be mounted in the cutter module for accurate heading and tracking of the position of the cutter module. The cutter head direction is automatically controlled by two steering arms (1 × L, 1 × R).
Natural Gamma Sensor	• Natural gamma sensors can be mounted to the top and/or the bottom of the cutter module. These sensors enables the operator to leave coal on the roof and/or floor to improve the coal quality or to enhance roof support in weak strata conditions.
Electric Controls	• Motor Control Circuits (MCC) for the cutter module motors are housed on the surface in the Electrical Control Module (ECM). Underground electrical components are housed in flame-proof enclosures.
Hydraulic Controls	• Underground hydraulic valves are provided with flame proof solenoids.

DIMENSIONS (All dimensions are approximate.)

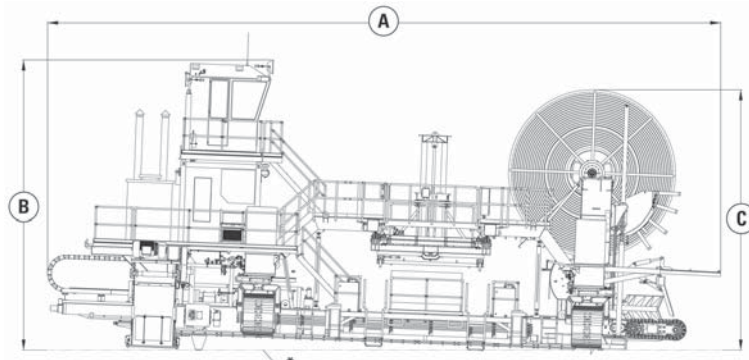

*Ground Level

Right Side View

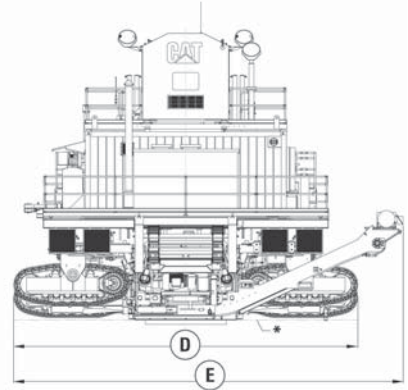

Rear View

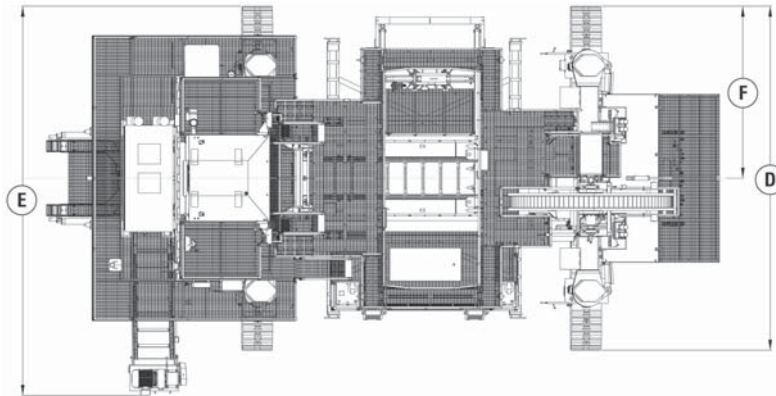

Top View

MODEL

HW300

MODEL	HW300	
A Overall Length	20 278 mm	66.5 ft
B Overall Height	8743 mm	28.7 ft
C Hose Reel Height	7844 mm	25.7 ft
D Track Width	10 369 mm	34.0 ft
E Overall Width	11 730 mm	38.5 ft
F Half Track Width	5185 mm	17.0 ft

HW300 OPTIONAL EQUIPMENT

Optional equipment may vary.
Consult your Cat dealer for details.

Gamma Detection System

- Allows mining in seam — leaving **predetermined amounts of coal** in the roof and floor. This system also allows the mining of coal in soft roof and/or soft floor conditions.

Tropical Package

- For hot-climate applications, this package extends the operating temperature of the equipment up to 55° C (131° F).

Right-Angle Discharge

- This feature discharges coal to the right or left of the machine.

Cat Push Beam Grapple

- This tool is available from the Cat dealer and mounts to the front of a wheel loader to provide safe and efficient transportation of push beams to and from the highwall mining system.

Generator Set

- A self-contained generator system is an option that can be sourced from the local Cat dealer. It provides electrical power to the highwall mining system in remote locations where connection to a utility grid is not practical.

HYDRAULIC EXCAVATORS

Front Shovels

Hydraulic Excavators

CONTENTS

FRONT SHOVELS

Specifications	7-3
Digging Envelopes	7-4
General Dimensions	7-5

HYDRAULIC EXCAVATORS

Specifications	7-8	Equipping Excavators:	
Shipping Dimensions	7-46	Long Reach	7-242
Major Component Weights	7-89	Long Reach Excavation	7-244
Range Dimensions:		Super Long Reach	7-247
One-piece Boom	7-109	Short Reach	7-249
Hydraulically Adjustable Boom	7-136	Machine Selection (tracks vs. wheels)	7-251
Lifting Capacity (definition)	7-141	Shoe Selection and Ground Pressure	7-252
Lifting Capacity at Ground Level (charts)	7-143	Quick Coupler Systems	7-258
Buckets	7-207	Ripping & Loading in Quarries	7-264
Bucket Capacity (definition)	7-216	Major Attachment Summary	7-267
Curl and Crowd Forces	7-216	Work Tools	7-277
Bucket Specifications	7-229	Cycle Time Estimating Charts	7-278
New Nomenclature for		Machine Operation	7-281
Hydraulic Excavator Buckets	7-231	Maximizing Production	
Bucket Types	7-233	with a Mass Excavator	7-281
Bucket Sales Support	7-237	Selecting a Mass Excavator	7-282
Working Weights (bucket & payload)	7-238	Earthmoving Production	7-284
		Production Estimating Tables	7-286
		Trenching Production	7-288

FRONT SHOVELS

CONTENTS

FRONT SHOVELS

Specifications	7-3
Digging Envelopes	7-4
General Dimensions	7-5

MODEL	385C FS	
Region Offerings	CIS, Europe, South America, Asia Pacific	
Engine Power — ISO 9249	390 kW	530 hp
Operating Weight*	90 080-91 700 kg	198,592-202,164 lb
Bucket Capacity Range (heaped)	5.7 m ³	7.4 yd ³
Engine Model	C18 ACERT™	
Rated Engine RPM	1800	
No. of Cylinders	6	
Displacement	18.1 L	1105 in ³
Max. Hydraulic Pump Output at Rated RPM	2 × 490 L/min	2 × 129 gpm
Relief Valve Settings:		
Implement Circuits	32 000 kPa	4640 psi
Swing	35 000 kPa	5075 psi
Travel Circuits	26 000 kPa	3770 psi
Pilot Circuits	4100 kPa	595 psi
Maximum Drawbar Pull	592 kN	133,200 lb
Maximum Travel Speed at Rated RPM	Two Speed	
Low	2.8 km/h	1.7 mph
High	4.5 km/h	2.8 mph
Overall Track Length**	5.84 m	19'2"
Track Gauge	2.75 m	9'0"
Extended	3.51 m	11'6"
Track Shoe Widths	650 mm	26"
Ground Contact Area with Standard Shoe	6.54 m ²	70.4 ft ²
Ground Pressures	138 kPa	20.0 psi
Fuel Tank Refill Capacity	1240 L	328 U.S. gal
Hydraulic System (includes tank)	995 L	263 U.S. gal
Hydraulic System	810 L	214 U.S. gal

*Operating weight includes counterweight and full fuel.

**Track length measured from center of idler to center of sprocket.

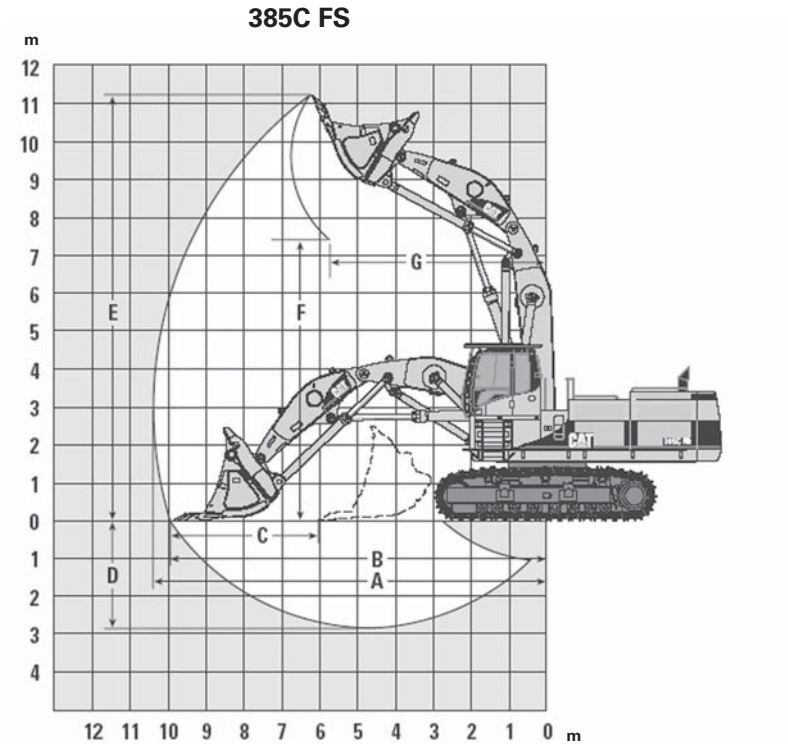

385C FS

Stick Length	3480 mm	11'5"
Boom Length	4600 mm	15'1"
Rock Bucket	5.2 m	17'1"
A Maximum Reach	10 350 mm	33'11"
B Maximum Reach at Ground Level	9900 mm	32'6"
C Maximum Level Crowd Distance	3920 mm	12'10"
D Maximum Digging Depth	2840 mm	9'4"
E Maximum Digging Height	11 260 mm	36'11"
F Maximum Dump Height	7430 mm	24'5"
G Reach at Maximum Dump Height	5690 mm	18'8"
Bucket Breakout Force (ISO)	538 kN	121,050 lb
Stick Breakout Force (ISO)	429 kN	96,530 lb

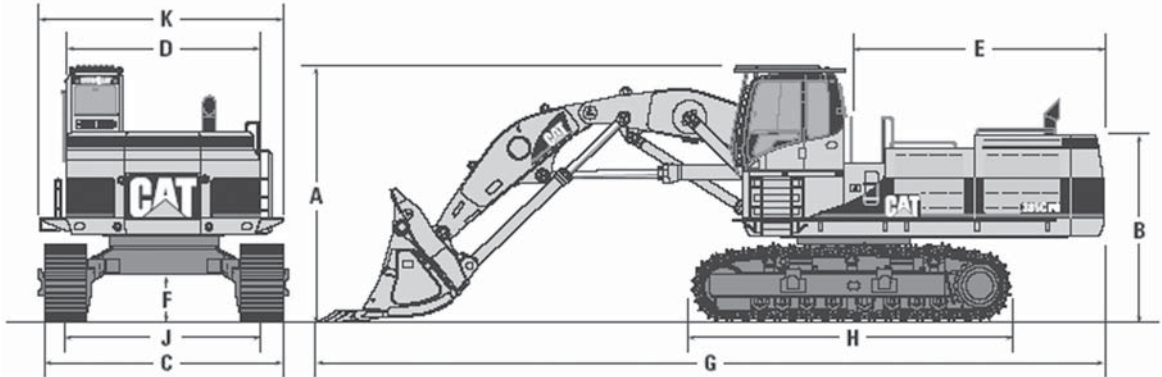

385C FS

Boom	4600 mm	15'1"
Stick	3480 mm	11'5"
A Boom Top Height	4500 mm	14'9"
Cab Top Height with FOPS	4660 mm	15'3"
Cab Top Height without FOPS	4520 mm	14'10"
B Engine Hood Height without Handrail	3460 mm	11'4"
C Overall Width		
650 mm (26") Shoes (retracted)	3400 mm	11'2"
750 mm (30") Shoes (retracted)	3500 mm	11'6"
650 mm (26") Shoes (extended)	4160 mm	13'8"
750 mm (30") Shoes (extended)	4260 mm	14'0"
D Upperstructure Width	3470 mm	11'5"
E Tail swing Radius	4590 mm	15'1"
F Minimum Ground Clearance	850 mm	2'9"
G Overall Length	14 250 mm	46'9"
H Track Length	5840 mm	19'2"
J Track Gauge Width		
Extended Position	3510 mm	11'6"
Retracted Position	2750 mm	9'0"

HYDRAULIC EXCAVATORS

CONTENTS

HYDRAULIC EXCAVATORS

Specifications	7-8	Equipping Excavators:	
Shipping Dimensions	7-46	Long Reach	7-242
Major Component Weights	7-89	Long Reach Excavation	7-244
Range Dimensions:		Super Long Reach	7-247
One-piece Boom	7-109	Short Reach	7-249
Hydraulically Adjustable Boom	7-136	Machine Selection (tracks vs. wheels)	7-251
Lifting Capacity (definition)	7-141	Shoe Selection and Ground Pressure	7-252
Lifting Capacity at Ground Level (charts)	7-143	Quick Coupler Systems	7-258
Buckets	7-207	Ripping & Loading in Quarries	7-264
Bucket Capacity (definition)	7-216	Major Attachment Summary	7-267
Curl and Crowd Forces	7-216	Work Tools	7-277
Bucket Specifications	7-229	Cycle Time Estimating Charts	7-278
New Nomenclature for		Machine Operation	7-281
Hydraulic Excavator Buckets	7-231	Maximizing Production	
Bucket Types	7-233	with a Mass Excavator	7-281
Bucket Sales Support	7-237	Selecting a Mass Excavator	7-282
Working Weights (bucket & payload)	7-238	Earthmoving Production	7-284
		Production Estimating Tables	7-286
		Trenching Production	7-288

MODEL	300.9D		301.4C Fixed Undercarriage		301.4C Extending Undercarriage	
Region Offerings	North America, South America, Canada, Australia, New Zealand, Europe, Africa, Middle East		North America, Canada, Australia, New Zealand, Europe, Africa, Middle East		North America, Canada, Australia, New Zealand, Europe, Africa, Middle East	
Flywheel Power	13.2 kW	18 hp	13.2 kW	18 hp	13.2 kW	18 hp
Operating Weight*	985 kg	2170 lb	1470 kg	3241 lb	1558 kg	3435 lb
Bucket Capacity Range (heaped)	0.014- 0.018 m ³	0.027- 0.023 yd³	0.018- 0.056 m ³	0.023- 0.073 yd³	0.018- 0.056 m ³	0.023- 0.073 yd³
Engine Model	Yanmar 31NV70		Yanmar 3TNV76		Yanmar 3TNV76	
Emission Standards	U.S. EPA Tier 4 Final/ EU Stage IIIB		Tier 4 Final/Stage IIIB		Tier 4 Final/Stage IIIB	
Rated Engine RPM	2100		2200		2200	
No. of Cylinders	3		3		3	
Bore	70 mm	2.8"	—	—	—	—
Stroke	74 mm	2.9"	—	—	—	—
Displacement	854 cm ³	52 in³	1116 cm ³	68.1 in³	1116 cm ³	68.1 in³
Relief Valve Settings:						
Implement Circuits	17 MPa	2465 psi	20 MPa	2901 psi	20 MPa	2901 psi
Travel Circuits	17 MPa	2465 psi	20 MPa	2901 psi	20 MPa	2901 psi
Swing Circuits	17 MPa	2465 psi	15 MPa	2176 psi	15 MPa	2176 psi
Maximum Travel Speed at Rated RPM	1.8 km/h	1.12 mph	2.5 km/h	1.55 mph	2.5 km/h	1.55 mph
Width of Standard Track Shoe	180 mm	7"	230 mm	9"	230 mm	9"
Overall Track Length	1220 mm	4'0"	1460 mm	4'9"	1460 mm	4'9"
Track Gauge	520-680 mm	20.5-26.7"	760 mm	30"	1070 mm	30"
Fuel Tank Refill Capacity	10 L	2.64 U.S. gal	24 L	6.3 U.S. gal	24 L	6.3 U.S. gal
Hydraulic System (includes tank)	14 L	3.7 U.S. gal	20 L	5.3 U.S. gal	20 L	5.3 U.S. gal

*Operating weight includes coolant, lubricants, full fuel tank, cab, standard shoes, bucket, medium stick, and operator 75 kg (165 lb).

NOTE: Certain models may not be available in all Sales areas.

Specifications also vary by Sales area.
Contact your Cat® dealer for details.

MODEL	301.7D Fixed Undercarriage		301.7D Extending Undercarriage		301.7D CR Extending Undercarriage	
Region Offerings	North America, South America, Canada, Australia, New Zealand, Europe, Africa, Middle East		North America, South America, Canada, Australia, New Zealand, Europe, Africa, Middle East		North America, Canada, Australia, New Zealand, Europe, Africa, Middle East	
Flywheel Power	13.2 kW	18 hp	13.2 kW	18 hp	13.2 kW	18 hp
Operating Weight*	1800 kg	3970 lb	1925 kg	4245 lb	1690 kg	3726 lb
With Additional Counterweight	—		—		1740 kg	3836 lb
Bucket Capacity Range (heaped)	0.018- 0.056 m ³	0.023- 0.073 yd³	0.018- 0.056 m ³	0.023- 0.073 yd³	0.018- 0.056 m ³	0.023- 0.073 yd³
Engine Model	Yanmar 3TNV76		Yanmar 3TNV76		Yanmar 3TNV76	
Emission Standards	Tier 4 Final/Stage IIIB		Tier 4 Final/Stage IIIB		Tier 4 Final/Stage IIIB	
Rated Engine RPM	2200		2200		2200	
No. of Cylinders	3		3		3	
Displacement	1116 cm ³	68.1 in³	1116 cm ³	68.1 in³	1116 cm ³	68.1 in³
Max. Implement Hydraulic Pump Output at Rated RPM	2 × 23.8/ 1 × 19 L/min	2 × 6.29/ 1 × 5 gpm	2 × 23.8/ 1 × 19 L/min	2 × 6.29/ 1 × 5 gpm	2 × 23.8/ 1 × 19 L/min	2 × 6.29/ 1 × 5 gpm
Relief Valve Settings:						
Implement Circuits	20 MPa	2901 psi	20 MPa	2901 psi	20 MPa	2901 psi
Travel Circuits	20 MPa	2901 psi	20 MPa	2901 psi	20 MPa	2901 psi
Swing Circuits	12.5 MPa	1813 psi	12.5 MPa	1813 psi	15 MPa	2176 psi
	Two Speed Travel		Two Speed Travel		Two Speed Travel	
Maximum Travel Speed at Rated RPM	Lo: 2.8 km/h	1.74 mph	Lo: 2.8 km/h	1.74 mph	Lo: 2.8 km/h	1.74 mph
	Hi: 5.6 km/h	3.48 mph	Hi: 5.6 km/h	3.48 mph	Hi: 5.6 km/h	3.48 mph
Width of Standard Track Shoe	230 mm	9"	230 mm	9"	230 mm	9"
Overall Track Length	1445 mm	4'9"	1605 mm	5'3"	1607 mm	5'3"
Track Gauge	760 mm	30"	1070 mm	42"	1070 mm	42"
Fuel Tank Refill Capacity	24 L	6.3 U.S. gal	24 L	6.3 U.S. gal	19 L	5 U.S. gal
Hydraulic System (includes tank)	21 L	5.5 U.S. gal	21 L	5.5 U.S. gal	20 L	5.3 U.S. gal

*Operating weight includes coolant, lubricants, full fuel tank, cab, standard shoes, bucket, medium stick, and operator 75 kg (165 lb).

NOTE: Certain models may not be available in all Sales areas.

Specifications also vary by Sales area.
Contact your Cat dealer for details.

MODEL	302.2D		302.4D		302.7D CR	
Region Offerings	Europe, Africa, Middle East		North America, South America, Canada, Australia, New Zealand, Europe, Africa, Middle East		North America, South America, Canada, Australia, New Zealand, Europe, Africa, Middle East	
Flywheel Power	13.2 kW	18 hp	13.2 kW	18 hp	13.2 kW	17.7 hp
Operating Weight*	2135 kW	4707 lb	2410 kg	5313 lb	2670 kg	5885 lb
Bucket Capacity Range (heaped)	0.035- 0.092 m ³	0.046- 0.12 yd³	0.035- 0.092 m ³	0.046- 0.12 yd³	0.035- 0.092 m ³	0.046- 0.12 yd³
Engine Model	Yanmar 3TNV76		Yanmar 3TNV76		Yanmar 3TNV76	
Emission Standards	Stage IIIB Equivalent		Tier 4 Final/Stage IIIB		Tier 4 Final/Stage IIIB	
Rated Engine RPM	2200		2200		2200	
No. of Cylinders	3		3		3	
Displacement	1116 cm ³	68.1 in³	1116 cm ³	68.1 in³	1115 cm ³	68 in³
Max. Implement Hydraulic Pump Output at Rated RPM	23.8 + 23.8 + 19 + 6.4 L/min	6.29 + 6.29 + 5 + 1.7 gpm	2 × 26.1/ 1 × 19.4 L/min	2 × 6.29/ 1 × 5.1 gpm	2 × 30.5/ 21.2 + 7.2 L/min	2 × 8.1/ 5.6 + 1.9 gpm
Relief Valve Settings:						
Implement Circuits	30 L/min @ 170 bar	8 gpm @ 2465 psi	24 MPa	3480 psi	22.5 MPa	3263 psi
Travel Circuits	—	—	24 MPa	3480 psi	22.5 MPa	3263 psi
Swing Circuits	17 L/min @ 200 bar	4.5 gpm @ 2900 psi	15 MPa	2176 psi	22.5 MPa	3263 psi
	Two Speed Travel		Two Speed Travel		Two Speed Travel	
Maximum Travel Speed at Rated RPM	Lo: 2.8 km/h Hi: 5.6 km/h	1.74 mph 3.48 mph	Lo: 2.8 km/h Hi: 5.6 km/h	1.74 mph 3.48 mph	Lo: 2.1 km/h Hi: 3.8 km/h	1.3 mph 2.4 mph
Width of Standard Track Shoe	250 mm	10"	250 mm	10"	300 mm	12"
Overall Track Length	1710 mm	5'7"	1840 mm	6'0"	2006 mm	79"
Track Gauge:						
Standard Undercarriage	—	—	1150 mm	42.3"	1270 mm	50"
Variable Width Undercarriage	740-1050 mm	2'5"-3'5"	—	—	—	—
Fuel Tank Refill Capacity	24 L	6.3 U.S. gal	24 L	6.3 U.S. gal	35.2 L	9.3 U.S. gal
Hydraulic System (includes tank)	21 L	5.5 U.S. gal	21 L	5.5 U.S. gal	26.5 L	7.0 U.S. gal

*Operating weight includes coolant, lubricants, full fuel tank, cab, standard shoes, bucket, medium stick, and operator 75 kg (165 lb).

NOTE: Certain models may not be available in all Sales areas.

Specifications also vary by Sales area.

Contact your Cat dealer for details.

MODEL	303E CR		303.5E CR		303.5E2 CR	
Region Offerings	North America, South America, Canada, Australia, New Zealand		North America, South America, Canada, Australia, New Zealand, Europe, Africa, Middle East		North America**, South America***, Canada***, Australia***, New Zealand***, Africa***, Middle East***	
Flywheel Power	17.5 kW	23.5 hp	23.6 kW	31.6 hp	17.5 kW	23.5 hp
Operating Weight*	3533 kg	7789 lb	3692 kg	8139 lb	3860 kg	8511 lb
Bucket Capacity Range (heaped)	0.05-0.20 m ³	0.06-0.26 yd³	0.05-0.16 m ³	0.06-0.21 yd³	0.05-0.16 m ³	0.06-0.21 yd³
Engine Model	Cat C1.3		Cat C1.8		Cat C1.7	
Emission Standards	Tier 4 Final/Stage IIIB		Tier 4 Interim/ Stage IIIB Equivalent		Tier 4 Final/Stage IIIB** OR Tier 4 Interim/ Stage IIIB Equivalent***	
Rated Engine RPM	2400		2400		2200	
No. of Cylinders	3		3		3	
Bore	78 mm	3.1"	87 mm	3.4"	87 mm	3.4"
Stroke	88 mm	3.5"	102.4 mm	4"	92.4 mm	3.6"
Displacement	1.261 L	77 in³	1.8 L	110 in³	1.7 L	104 in³
Max. Implement Hydraulic Pump Output at Rated RPM	87.6 L/min	23.14 gpm	87.6 L/min	23.14 gpm	100 L/min	26.4 gpm
Relief Valve Settings:						
Implement Circuits	24.5 MPa	3553 psi	24.5 MPa	3553 psi	24.5 MPa	3553 psi
Travel Circuits	24.5 MPa	3553 psi	24.5 MPa	3553 psi	24.5 MPa	3553 psi
Swing Circuits	19.6 MPa	2842 psi	18.1 MPa	2625 psi	21.6 MPa	3132 psi
Maximum Drawbar Pull	30.9 kN	6947 lbf	31.0 kN	6969 lbf	31.1 kN	6992 lbf
	Two Speed Travel		Two Speed Travel		Two Speed Travel	
Maximum Travel Speed at Rated RPM	Lo: 2.42 km/h	1.5 mph	Lo: 2.6 km/h	1.6 mph	Lo: 2.8 km/h	1.7 mph
	Hi: 4.51 km/h	2.8 mph	Hi: 4.6 km/h	2.8 mph	Hi: 4.1 km/h	2.5 mph
Width of Standard Track Shoe	130 mm	5.1"	300 mm	12"	300 mm	1'0"
Overall Track Length	2057 mm	6'9"	2220 mm	7'3"	2220 mm	7'3"
Ground Contact Area with Std. Shoe	1.1 m ²	1705 in²	1.19 m ²	1845 in²	1.19 m ²	1845 in²
Track Gauge	1250 mm	49.2"	1480 mm	58"	1480 mm	58"
Fuel Tank Refill Capacity	45 L	11.9 U.S. gal	46 L	12.2 U.S. gal	57 L	15.1 U.S. gal
Hydraulic System (includes tank)	55 L	14.5 U.S. gal	65 L	17.2 U.S. gal	58 L	15.3 U.S. gal

*Operating weight includes coolant, lubricants, full fuel tank, cab, standard shoes, bucket, medium stick, and operator 75 kg (165 lb).

**Meets Tier 4 Final/Stage IIIB emission standards.

***Meets Tier 4 Interim/Stage IIIB Equivalent emission standards.

NOTE: Certain models may not be available in all Sales areas.

Specifications also vary by Sales area.
Contact your Cat dealer for details.

MODEL	304E2 CR		305E2 CR		305.5E2 CR	
Region Offerings	North America**, South America***, Canada***, Australia***, New Zealand***, Europe***, Africa***, Middle East***		North America**, South America***, Canada***, Australia***, New Zealand***, Europe***, Africa***, Middle East***		North America**, South America***, Canada***, Australia***, New Zealand***, Europe***, Africa***, Middle East***	
Flywheel Power	30.0 kW	40.2 hp	30.0 kW	40.2 hp	32.9 kW	44.1 hp
Operating Weight*	4050 kg 8930 lb		5107 kg 11,261 lb		5335 kg 11,764 lb	
with Standard Counterweight	—		—		5500 kg 12,128 lb	
with Additional Counterweight	—		—		—	
Bucket Capacity Range (heaped)	0.05-0.16 m ³	0.06-0.21 yd³	0.05-0.28 m ³	0.07-0.37 yd³	0.05-0.28 m ³	0.07-0.37 yd³
Engine Model	Cat C2.4		Cat C2.4		Cat C2.4	
Emission Standards	Tier 4 Final/Stage IIIB** OR Tier 4 Interim/ Stage IIIB Equivalent***		Tier 4 Final/Stage IIIB** OR Tier 4 Interim/ Stage IIIB Equivalent***		Tier 4 Final/Stage IIIB** OR Tier 4 Interim/ Stage IIIB Equivalent***	
Rated Engine RPM	2200		2200		2400	
No. of Cylinders	4		4		4	
Bore	87 mm	3.4"	87 mm	3.4"	87 mm	3.4"
Stroke	102.4 mm	4.0"	102.4 mm	4.0"	102.4 mm	4.0"
Displacement	2.4 L	146 in³	2.4 L	146 in³	2.4 L	146 in³
Max. Implement Hydraulic Pump Output at Rated RPM	100 L/min	26.4 gpm	150L/min	39.6 gpm	163 L/min	43.1 gpm
Relief Valve Settings:						
Implement Circuits	24.5 MPa	3553 psi	24.5 MPa	3553 psi	24.5 MPa	3553 psi
Travel Circuits	24.5 MPa	3553 psi	24.5 MPa	3553 psi	24.5 MPa	3553 psi
Swing Circuits	21.6 MPa	3132 psi	21.6 MPa	3132 psi	21.6 MPa	3132 psi
Maximum Drawbar Pull	31.0 kN	6969 lbf	45.2 kN	10,161 lbf	47.8 kN	10,746 lbf
	Two Speed Travel		Two Speed Travel		Two Speed Travel	
Maximum Travel Speed at Rated RPM	Lo: 3.1 km/h	1.9 mph	Lo: 3.0 km/h	1.9 mph	Lo: 3.0 km/h	1.9 mph
	Hi: 5.1 km/h	3.2 mph	Hi: 4.5 km/h	2.8 mph	Hi: 4.6 km/h	2.9 mph
Width of Standard Track Shoe	350 mm	1'2"	400 mm	1'4"	400 mm	1'4"
Overall Track Length	2220 mm	7'3"	2580 mm	8'6"	2580 mm	8'6"
Ground Contact Area with Std. Shoe	1.19 m ²	1845 in²	1.8 m ²	2796 in²	1.8 m ²	2796 in²
Track Gauge	1580 mm	62"	1580 mm	62"	1580 mm	62"
Fuel Tank Refill Capacity	57 L	15.1 U.S. gal	71 L	18.8 U.S. gal	71 L	18.8 U.S. gal
Hydraulic System (includes tank)	58 L	15.3 U.S. gal	66 L	17.4 U.S. gal	66 L	17.4 U.S. gal

*Operating weight includes coolant, lubricants, full fuel tank, cab, standard shoes, bucket, medium stick, and operator 75 kg (165 lb).

**Meets Tier 4 Final/Stage IIIB emission standards.

***Meets Tier 4 Interim/Stage IIIB Equivalent emission standards.

NOTE: Certain models may not be available in all Sales areas.

Specifications also vary by Sales area.

Contact your Cat dealer for details.

MODEL	307E2		308E2 CR SB	
Region Offerings	North America, Canada, Europe		North America, Canada, Australia, New Zealand, Europe	
Flywheel Power	37.7 kW	50.6 hp	48.5 kW	65 hp
Operating Weight*				
with Standard Counterweight	7390 kg	16,295 lb	8400 kg	18,518 lb
with Additional Counterweight	—		8650 kg	19,070 lb
Bucket Capacity Range (heaped)	0.1-0.37 m ³	0.13-0.48 yd³	0.1-0.37 m ³	0.13-0.48 yd³
Engine Model	Cat C2.4		Cat C3.3B	
Emission Standards	Tier 4 Final/Stage IIIB		Tier 4 Final/Stage IIIB	
Rated Engine RPM	2200		2400	
No. of Cylinders	4		4	
Bore	87 mm	3.4"	94 mm	3.7"
Stroke	102.4 mm	4.0"	120 mm	4.7"
Displacement	2.4 L	146 in³	3.33 L	203.2 in³
Max. Implement Hydraulic Pump Output at Rated RPM	154 L/min	40.7 gpm	160 L/min	42.27 gpm
Relief Valve Settings:				
Implement Circuits	28 MPa	4061 psi	28 MPa	4061 psi
Travel Circuits	28 MPa	4061 psi	32 MPa	4641 psi
Swing Circuits	28 MPa	4061 psi	24 MPa	3481 psi
Maximum Drawbar Pull	59.3 kN	13,331 lbf	63.3 kN	14,230 lbf
	Two Speed Travel		Two Speed Travel	
Maximum Travel Speed at Rated RPM	Lo: 3.2 km/h	2.0 mph	Lo: 2.8 km/h	1.7 mph
	Hi: 5.1 km/h	3.2 mph	Hi: 5.1 km/h	3.16 mph
Width of Standard Track Shoe	450 mm	1'6"	450 mm	18"
Overall Track Length	2760 mm	9'1"	2903 mm	9'6"
Ground Contact Area with Std. Shoe	2.11 m ²	3270 in²	3 m ²	4650 in²
Track Gauge	1750 mm	69"	1870 mm	73"
Fuel Tank Refill Capacity	135 L	35.7 U.S. gal	125 L	33 U.S. gal
Hydraulic System (includes tank)	78 L	20.6 U.S. gal	94 L	24.8 U.S. gal

*Operating weight includes coolant, lubricants, full fuel tank, cab, standard shoes, bucket, medium stick, and operator 75 kg (165 lb).

NOTE: Certain models may not be available in all Sales areas.

Specifications also vary by Sales area.

Contact your Cat dealer for details.

MODEL	311F L RR		312D2		312D2 GC	
Region Offerings	North America, Europe, Australia, New Zealand and Polynesia, Japan		Asia Pacific		China	
Engine Power:						
ISO 9249	52 kW	70 hp	67 kW	90 hp	56 kW	75 hp
SAE J1349	52 kW	70 hp	67 kW	90 hp	56 kW	75 hp
Operating Weight*	12 400-13 900 kg	27,300-30,600 lb	12 900-13 600 kg	28,440-29,980 lb	12 500 kg	27,560 lb
Bucket Capacity Range (heaped)	0.20-0.76 m ³	0.27-1.0 yd³	0.31-0.76 m ³	0.4-1.0 yd³	0.53 m ³	0.69 yd³
Engine Model	C3.4B		3054C		3054C	
Emission Standards	Tier 4 Final/Stage IIIB/ Japan 2014 (Tier 4 Final)		Tier 2/Stage II Equivalent		China Stage II Nonroad Equivalent	
Rated Engine RPM	1800		1800		1800	
No. of Cylinders	4		4		4	
Bore	99 mm	3.90"	105 mm	4.13"	105 mm	4.13"
Stroke	110 mm	4.33"	127 mm	5.00"	127 mm	5.00"
Displacement	3.4 L	207 in³	4.4 L	269 in³	4.4 L	269 in³
Max. Implement Hydraulic Pump Output at Rated RPM	2 × 125 L/min	2 × 33 gpm	2 × 127 L/min	2 × 34 gpm	2 × 127 L/min	2 × 34 gpm
Relief Valve Settings:						
Implement Circuits	30 500 kPa	4424 psi	30 500 kPa	4424 psi	30 500 kPa	4424 psi
Travel Circuits	35 000 kPa	5076 psi	35 000 kPa	5080 psi	35 000 kPa	5076 psi
Swing Circuits	23 000 kPa	3336 psi	23 000 kPa	3340 psi	23 000 kPa	3336 psi
Pilot Circuits	4120 kPa	598 psi	4100 kPa	600 psi	4120 kPa	598 psi
Maximum Drawbar Pull	114.3 kN	25,696 lb	114 kN	25,630 lbf	114 kN	25,628 lbf
	Two Speed Travel		Two Speed Travel		Two Speed Travel	
Maximum Travel Speed at Rated RPM	Lo: 3.6 km/h	2.2 mph	Lo: 3.8 km/h	2.4 mph	Lo: 3.5 km/h	2.2 mph
	Hi: 5.4 km/h	3.4 mph	Hi: 5.6 km/h	3.5 mph	Hi: 5.1 km/h	3.2 mph
Width of Standard Track Shoe	500 mm	1'8"	500 mm	1'8"	500 mm	20"
Overall Track Length	3490 mm	11'5"	3490 mm	11'5"	3490 mm	11'5"
Ground Contact Area with Std. Shoe	3.03 m ²	4700 in²	3.03 m ²	4700 in²	3.03 m ²	4700 in²
Track Gauge	1990 mm	6'6"	1990 mm	6'6"	1990 mm	6'6"
Fuel Tank Refill Capacity	210 L	55.5 U.S. gal	250 L	66 U.S. gal	250 L	66 U.S. gal
Hydraulic System (includes tank)	160 L	42.3 U.S. gal	104 L	27.5 U.S. gal	150 L	39.6 U.S. gal

*Operating weight includes coolant, lubricants, full fuel tank, cab, standard shoes, bucket, medium stick, and operator 75 kg (165 lb).

NOTE: Certain models may not be available in all Sales areas.

Specifications also vary by Sales area.

Contact your Cat dealer for details.

MODEL	312D2 L		312E		312E L	
Region Offerings	Middle East, Africa, CIS, Asia Pacific, South America		Europe, Australia, New Zealand and Polynesia, Japan		North America, Europe, Australia, New Zealand and Polynesia	
Engine Power:						
ISO 9249	67 kW	90 hp	68 kW	91 hp	68 kW	91 hp
SAE J1349	N/A		68 kW	91 hp	68 kW	91 hp
Operating Weight*	13 200- 13 900 kg	29,100- 30,640 lb	13 200- 15 700 kg	29,100- 34,620 lb	13 200- 15 700 kg	29,100- 34,620 lb
Bucket Capacity Range (heaped)	0.31-0.76 m ³	0.4-1.0 yd ³	0.20-0.76 m ³	0.27-0.99 yd ³	0.20-0.76 m ³	0.27-1.0 yd ³
Engine Model	3054C		C4.4 ACERT		C4.4 ACERT	
Emission Standards	Tier 2/Stage II Equivalent		Tier 4 Interim/Stage IIIB/ Japan 2011 (Tier 4 Interim) Equivalent		Tier 4 Interim/ Stage IIIB Equivalent	
Rated Engine RPM	2200		1800		1800	
No. of Cylinders	4		4		4	
Bore	105 mm	4.13"	105 mm	4.13"	105 mm	4.13"
Stroke	127 mm	5.00"	127 mm	5.00"	127 mm	5.00"
Displacement	4.4 L	269 in ³	4.4 L	269 in ³	4.4 L	269 in ³
Max. Implement Hydraulic Pump Output at Rated RPM	2 x 127 L/min	2 x 34 gpm	2 x 127 L/min	2 x 34 gpm	2 x 127 L/min	2 x 34 gpm
Relief Valve Settings:						
Implement Circuits	30 500 kPa	4424 psi	30 500 kPa	4424 psi	30 500 kPa	4424 psi
Travel Circuits	35 000 kPa	5080 psi	35 000 kPa	5076 psi	35 000 kPa	5076 psi
Swing Circuits	23 000 kPa	3340 psi	23 000 kPa	3336 psi	23 000 kPa	3336 psi
Pilot Circuits	4100 kPa	600 psi	4120 kPa	598 psi	4120 kPa	598 psi
Maximum Drawbar Pull	114 kN	25,630 lbf	114 kN	25,628 lbf	114 kN	25,628 lbf
	Two Speed Travel					
Maximum Travel Speed at Rated RPM	Lo: 3.8 km/h	2.4 mph	5.5 km/h	3.4 mph	5.5 km/h	3.4 mph
	Hi: 5.6 km/h	3.5 mph				
Width of Standard Track Shoe	500 mm	1'8"	700 mm	28"	700 mm	28"
Overall Track Length	3750 mm	12'4"	3750 mm	12'4"	3750 mm	12'4"
Ground Contact Area with Std. Shoe	3.29 m ²	5100 in ²	4.2 m ²	6600 in ²	4.6 m ²	7150 in ²
Track Gauge	1990 mm	6'6"	1990 mm	6'6"	1990 mm	6'6"
Fuel Tank Refill Capacity	250 L	66 U.S. gal	250 L	66.04 U.S. gal	250 L	66.04 U.S. gal
Hydraulic System (includes tank)	104 L	27.5 U.S. gal	162 L	42.8 U.S. gal	162 L	42.8 U.S. gal

*Operating weight includes coolant, lubricants, full fuel tank, standard shoes, bucket, medium stick, and operator 75 kg (165 lb).

NOTE: Certain models may not be available in all Sales areas.

Specifications also vary by Sales area.

Contact your Cat dealer for details.

MODEL	312F GC		313D2		313D2 LGP	
Region Offerings	Japan		China, Asia Pacific		Asia Pacific	
Engine Power:						
ISO 9249	55 kW	74 hp	67 kW	90 hp	67 kW	90 hp
SAE J1349	54 kW	72 hp	67 kW	90 hp	67 kW	90 hp
Operating Weight*	12 500- 13 900 kg	27,600- 30,600 lb	13 400 kg	29,550 lb	16 000 kg	35,300 lb
Bucket Capacity Range (heaped)	0.20-0.76 m ³	0.27-1.0 yd³	0.65 m ³	0.85 yd³	0.65 m ³	0.84 yd³
Engine Model	C3.4B		3054C		3054C	
Emission Standards	Tier 4 Final/Stage IIIB/ Japan 2014 (Tier 4 Final)		China Stage II Nonroad Equivalent		Tier 2/Stage II Equivalent	
Rated Engine RPM	1700		1800		1800	
No. of Cylinders	4		4		4	
Bore	99 mm	3.9"	105 mm	4.13"	105 mm	4.13"
Stroke	110 mm	4.33"	127 mm	5.00"	127 mm	5.00"
Displacement	3.4 L	207 in³	4.4 L	269 in³	4.4 L	269 in³
Max. Implement Hydraulic Pump Output at Rated RPM	2 x 127 L/min	2 x 33.6 gpm	2 x 127 L/min	2 x 34 gpm	2 x 127 L/min	2 x 34 gpm
Relief Valve Settings:						
Implement Circuits	30 500 kPa	5076 psi	30 500 kPa	4424 psi	30.5 MPa	4430 psi
Travel Circuits	35 000 kPa	5076 psi	35 000 kPa	5076 psi	35 MPa	5080 psi
Swing Circuits	23 000 kPa	3336 psi	23 000 kPa	3336 psi	23 MPa	3340 psi
Pilot Circuits	4120 kPa	598 psi	4120 kPa	598 psi	4120 kPa	598 psi
Maximum Drawbar Pull	109.9 kN	24,706 lb	114 kN	25,628 lbf	156 kN	34,980 lbf
	Two Speed Travel		Two Speed Travel		Two Speed Travel	
Maximum Travel Speed at Rated RPM	Lo: 3.6 km/h	2.2 mph	Lo: 3.8 km/h	2.4 mph	Lo: 2.8 km/h	1.7 mph
	Hi: 5.5 km/h	3.4 mph	Hi: 5.6 km/h	3.5 mph	Hi: 4.6 km/h	2.9 mph
Width of Standard Track Shoe	500 mm	1'8"	500 mm	1'11"	960 mm	3'2"
Overall Track Length	3490 mm	11'5"	3490 mm	11'5"	4020 mm	13'2"
Ground Contact Area with Std. Shoe	3.03 m ²	4700 in²	3.03 m ²	4700 in²	6.6 m ²	10,230 in²
Track Gauge	1990 mm	6'6"	1990 mm	6'6"	2080 mm	6'10"
Fuel Tank Refill Capacity	250 L	66 U.S. gal	250 L	66 U.S. gal	250 L	66 U.S. gal
Hydraulic System (includes tank)	164 L	43.3 U.S. gal	104 L	27.5 U.S. gal	164 L	43.32 U.S. gal

*Operating weight includes coolant, lubricants, full fuel tank, standard shoes, bucket, medium stick, and operator 75 kg (165 lb).

NOTE: Certain models may not be available in all Sales areas.

Specifications also vary by Sales area.
Contact your Cat dealer for details.

MODEL	313F L GC		314E CR		314E LCR	
Region Offerings	North America, Europe, Turkey		Australia, New Zealand and Polynesia, Japan		North America, Europe, Australia, New Zealand and Polynesia, Japan	
Engine Power:						
ISO 9249	55 kW	74 hp	67 kW	89 hp	67 kW	89 hp
SAE J1349	54 kW	72 hp	67 kW	89 hp	67 kW	89 hp
Operating Weight*	13 200-14 600 kg	29,100-32,200 lb	13 300-15 200 kg	29,300-33,500 lb	14 500-17 100 kg	31,970-37,710 lb
Bucket Capacity Range (heaped)	0.20-0.76 m ³	0.27-1.0 yd³	0.20-0.76 m ³	0.76-1.00 yd³	0.20-0.76 m ³	0.76-1.00 yd³
Engine Model	C3.4B		C4.4 ACERT		C4.4 ACERT	
Emission Standards	Tier 4 Final/Stage IIIB/ Japan 2014 (Tier 4 Final)		Tier 4 Interim/Stage IIIB/ Japan 2011 (Tier 4 Interim) Equivalent		Tier 4 Interim/Stage IIIB/ Japan 2011 (Tier 4 Interim) Equivalent	
Rated Engine RPM	1700		1800		1800	
No. of Cylinders	4		4		4	
Bore	99 mm	3.9"	105 mm	4.1"	105 mm	4.1"
Stroke	110 mm	4.33"	127 mm	5.00"	127 mm	5.00"
Displacement	3.4 L	207 in³	4.4 L	270 in³	4.4 L	270 in³
Max. Implement Hydraulic Pump Output at Rated RPM	2 × 127 L/min	2 × 33.6 gpm	2 × 119 L/min	2 × 32 gpm	2 × 127 L/min	2 × 34 gpm
Relief Valve Settings:						
Implement Circuits	30 500 kPa	5076 psi	30 500 kPa	4420 psi	30 500 kPa	4420 psi
Travel Circuits	35 000 kPa	5076 psi	35 000 kPa	5080 psi	35 000 kPa	5080 psi
Swing Circuits	23 000 kPa	3336 psi	23 000 kPa	3340 psi	23 000 kPa	3340 psi
Pilot Circuits	4120 kPa	598 psi	4120 kPa	600 psi	4120 kPa	600 psi
Maximum Drawbar Pull	109.9 kN	24,706 lb	113 kN	25,400 lbf	113 kN	25,400 lbf
	Two Speed Travel					
Maximum Travel Speed at Rated RPM	Lo: 3.6 km/h	2.2 mph	5.4 km/h	3.4 mph	5.4 km/h	3.4 mph
	Hi: 5.4 km/h	3.4 mph				
Width of Standard Track Shoe	500 mm	1'8"	500 mm	1'11"	500 mm	1'11"
Overall Track Length	3740 mm	12'3"	3490 mm	11'5"	3750 mm	11'5"
Ground Contact Area with Std. Shoe	3.03 m ²	4700 in²	3.03 m ²	4700 in²	3.29 m ²	5100 in²
Track Gauge	1990 mm	6'6"	1990 mm	6'6"	1990 mm	6'6"
Fuel Tank Refill Capacity	250 L	66 U.S. gal	178 L	47 U.S. gal	178 L	47 U.S. gal
Hydraulic System (includes tank)	164 L	43.3 U.S. gal	160 L	42.3 U.S. gal	162 L	42.8 U.S. gal

*Operating weight includes coolant, lubricants, full fuel tank, standard shoes, bucket, medium stick, and operator 75 kg (165 lb).

NOTE: Certain models may not be available in all Sales areas.

Specifications also vary by Sales area.
Contact your Cat dealer for details.

MODEL	316E L		318D2 L		318E L	
Region Offerings	North America, Europe, Australia, New Zealand and Polynesia, Japan		Middle East, Africa, CIS, South America, Asia Pacific, China		North America, Europe, Australia, New Zealand and Polynesia	
Engine Power:						
ISO 9249	85 kW	113 hp	82 kW	110 hp	85 kW	113 hp
SAE J1349	85 kW	113 hp	82 kW	110 hp	85 kW	113 hp
Operating Weight*	17 200- 18 700 kg	37,920- 41,230 lb	17 000- 17 800 kg	37,490- 39,250 lb	18 600-19 500 kg	41,010- 43,000 lb
Bucket Capacity Range (heaped)	0.35-1.09 m ³	0.46-1.43 yd³	0.73-1.09 m ³	0.96-1.43 yd³	0.35-0.91 m ³	0.46-1.19 yd³
Engine Model	C4.4 ACERT		3054CA		C4.4 ACERT	
Emission Standards	Tier 4 Interim/Stage IIIB/ Japan 2011 (Tier 4 Interim) Equivalent		Tier 2/Stage II/ China Stage II Nonroad Equivalent		Tier 4 Interim/Stage IIIB Equivalent	
Rated Engine RPM	1950		1950		1950	
No. of Cylinders	4		4		4	
Bore	105 mm	4.13"	105 mm	4.13"	105 mm	4.13"
Stroke	127 mm	5.00"	127 mm	5.00"	127 mm	5.00"
Displacement	4.4 L	269 in³	4.4 L	269 in³	4.4 L	269 in³
Max. Implement Hydraulic Pump Output at Rated RPM	2 × 150 L/min	2 × 40 gpm	2 × 136 L/min	2 × 36 gpm	2 × 150 L/min	2 × 40 gpm
Relief Valve Settings:						
Implement Circuits	35 000 kPa	5076 psi	35 000 kPa	5080 psi	35 000 kPa	5076 psi
Travel Circuits	35 000 kPa	5076 psi	36 300 kPa	5265 psi	35 000 kPa	5076 psi
Swing Circuits	22 600 kPa	3278 psi	22 600 kPa	3280 psi	23 000 kPa	3336 psi
Pilot Circuits	4120 kPa	598 psi	4120 kPa	600 psi	4120 kPa	598 psi
Maximum Drawbar Pull	156.2 kN	35,115 lbf	156 kN	35,070 lbf	206.9 kN	46,513 lbf
Maximum Travel Speed at Rated RPM	5.2 km/h	3.2 mph	4.8 km/h	3.0 mph	3.9 km/h	2.4 mph
Width of Standard Track Shoe	700 mm	28"	600 mm	24"	600 mm	24"
Overall Track Length	3970 mm	13'0"	3970 mm	13'0"	4075 mm	13'4"
Ground Contact Area with Std. Shoe	4.8 m ²	6400 in²	4.1 m ²	6400 in²	4.3 m ²	6600 in²
Track Gauge	1990 mm	6'6"	1990 mm	6'6"	1990 mm	6'6"
Fuel Tank Refill Capacity	290 L	76.61 U.S. gal	300 L	79.3 U.S. gal	290 L	79.61 U.S. gal
Hydraulic System (includes tank)	190 L	50.19 U.S. gal	121 L	32 U.S. gal	190 L	50.19 U.S. gal

*Operating weight includes coolant, lubricants, full fuel tank, cab, standard shoes, bucket, medium stick, and operator 75 kg (165 lb).

NOTE: Certain models may not be available in all Sales areas.

Specifications also vary by Sales area.

Contact your Cat dealer for details.

MODEL	M313D		M313D		M315D	
Region Offerings	North America, Australia, New Zealand		Europe		North America, Australia, New Zealand	
Engine Power:						
ISO 9249	95 kW	127 hp	95 kW	127 hp	101 kW	135 hp
ISO 14396	102 kW	137 hp	102 kW	137 hp	108 kW	145 hp
Operating Weight*	14 000- 16 200 kg	30,870- 35,721 lb	14 000- 16 200 kg	30,870- 35,721 lb	16 100- 18 300 kg	35,501- 40,352 lb
Bucket Capacity Range (heaped)	0.18-0.92 m ³	0.24-1.2 yd³	0.18-0.92 m ³	0.24-1.2 yd³	0.38-1.26 m ³	0.5-1.65 yd³
Engine Model	C4.4 ACERT		C4.4 ACERT		C4.4 ACERT	
Emission Standards	Tier 3/Stage IIIA/ UN/ECE R96 Stage IIIA		Stage IIIB		Tier 3/Stage IIIA/ UN/ECE R96 Stage IIIA	
Rated Engine RPM	2000		2000		2000	
No. of Cylinders	4		4		4	
Bore	105 mm	4.1"	105 mm	4.1"	105 mm	4.1"
Stroke	127 mm	5"	127 mm	5"	127 mm	5"
Displacement	4.4 L	269 in³	4.4 L	269 in³	4.4 L	269 in³
Max. Implement Hydraulic Pump Output at Rated RPM	190+80 L/min	50+21 gpm	190+80 L/min	50+21 gpm	220+80 L/min	58+21 gpm
Tires — standard	10.00-20 dual pneumatic		10.00-20 dual pneumatic		10.00-20 dual pneumatic	
— optional	11.00-20 dual pneumatic 445/70 R19.5 TL XF		11.00-20 dual pneumatic 445/70 R19.5 TL XF		10.00-20 dual solid rubber 445/70 R19.5 TL XF	
	10.00-20 (dual solid rubber)		10.00-20 (dual solid rubber)		11.00-20 dual pneumatic	
Maximum Drawbar Pull	71 kN	15,961 lbf	71 kN	15,961 lbf	102 kN	22,931 lbf
Maximum Travel Speed	37 km/h	23 mph	37 km/h	23 mph	34 km/h	21 mph
Wheel Base	2500 mm	8'2"	2500 mm	8'2"	2550 mm	8'4"
Width Over Tires**	2550 mm	8'4"	2550 mm	8'4"	2550 mm	8'4"
Ground Clearance**	370 mm	14.7"	370 mm	14.7"	370 mm	14.7"
Fuel Tank Refill Capacity	235 L	62 U.S. gal	235 L	62 U.S. gal	235 L	62 U.S. gal
Hydraulic System (includes tank)	180 L	48 U.S. gal	180 L	48 U.S. gal	220 L	58 U.S. gal

*Machine weight with medium stick, heavy counterweight, bucket, full fuel tank, and 75 kg (165 lb) operator.

**Tire pressure is 750 kPa (100 psi) with standard tires.

NOTE: Specifications also vary by Sales area.
Contact your Cat dealer for details.

MODEL	M315D		M315D2		M316D	
Region Offerings	Europe		Africa, Middle East, CIS, China, Asia Pacific, South America		North America, Australia, New Zealand	
Engine Power:						
ISO 9249	101 kW	135 hp	95 kW	129 hp	118 kW	158 hp
ISO 14396	108 kW	145 hp	102 kW	137 hp	123.5 kW	166 hp
Operating Weight*	16 100- 18 300 kg	35,501- 40,352 lb	14 000- 16 200 kg	30,870- 35,721 lb	17 000- 19 200 kg	37,478- 42,329 lb
Bucket Capacity Range (heaped)	0.38-1.26 m ³	0.5-1.65 yd³	0.18-0.92 m ³	0.24-1.2 yd³	0.35-1.09 m ³	0.46-1.43 yd³
Engine Model	C4.4 ACERT		C4.4 ACERT		C6.6 ACERT	
Emission Standards	Stage IIIB		Tier 3/Stage IIIA Equivalent UN/ECE R96 Stage IIIA/ China Stage III Nonroad		Tier 3/Stage IIIA/ UN/ECE R96 Stage IIIA	
Rated Engine RPM	2000		2000		1800	
No. of Cylinders	4		4		6	
Bore	105 mm	4.1"	105 mm	4.1"	105 mm	4.1"
Stroke	127 mm	5"	127 mm	5"	127 mm	5"
Displacement	4.4 L	269 in³	4.4 L	269 in³	6.6 L	403 in³
Max. Implement Hydraulic Pump Output at Rated RPM	220+80 L/min	58+21 gpm	190+80 L/min	50+21 gpm	250+80 L/min	66+21 gpm
Tires — standard	10.00-20 dual pneumatic		10.00-20 dual pneumatic		10.00-20 dual pneumatic	
— optional	10.00-20 dual solid rubber 445/70 R19.5 TL XF 11.00-20 dual pneumatic		10.00-20 dual solid rubber 11.00-20 dual pneumatic 445/70/R19.5 TL XF single pneumatic		10.00-20 dual solid rubber 445/70 R19.5 TL XF 11.00-20 dual pneumatic	
Maximum Drawbar Pull	102 kN	22,931 lbf	71 kN	15,961 lbf	103 kN	23,155 lbf
Maximum Travel Speed	34 km/h	21 mph	37 km/h	23 mph	37 km/h	23 mph
Wheel Base	2550 mm	8'4"	2500 mm	8'2"	2600 mm	8'6"
Width Over Tires**	2550 mm	8'4"	2550 mm	8'4"	2550 mm	8'4"
Ground Clearance**	370 mm	14.7"	370 mm	14.7"	370 mm	14.7"
Fuel Tank Refill Capacity	235 L	62 U.S. gal	235 L	62 U.S. gal	310 L	82 U.S. gal
Hydraulic System (includes tank)	220 L	58 U.S. gal	180 L	48 U.S. gal	230 L	61 U.S. gal

*Machine weight with medium stick, heavy counterweight, bucket, full fuel tank, and 75 kg (165 lb) operator.

**Tire pressure is 750 kPa (100 psi) with standard tires.

NOTE: Specifications also vary by Sales area.
Contact your Cat dealer for details.

MODEL	M317D2		M318D		M320D2	
Region Offerings	Africa, Middle East, CIS, China, Asia Pacific, South America		Turkey, Australia, New Zealand		Africa, Middle East, CIS, China, Asia Pacific, South America	
Engine Power:						
ISO 9249	101 kW	135 hp	124 kW	166 hp	124 kW	166 hp
ISO 14396	108 kW	145 hp	129.5 kW	174 hp	129 kW	173 hp
Operating Weight*	16 100- 18 300 kg	35,501- 40,352 lb	18 200- 20 100 kg	40,124- 44,312 lb	18 200- 20 100 kg	40,124- 44,312 lb
Bucket Capacity Range (heaped)	0.35-1.09 m ³ 0.46-1.43 yd³		0.35-1.18 m ³ 0.46-1.54 yd³		0.35-1.18 m ³ 0.46-1.54 yd³	
Engine Model	C4.4 ACERT		C6.6 ACERT		C7.1 ACERT	
Emission Standards	Tier 3/Stage IIIA Equivalent UN/ECE R96 Stage IIIA/ China Stage III Nonroad		Tier 3/Stage IIIA/ UN/ECE R96 Stage IIIA		Tier 3/Stage IIIA Equivalent UN/ECE R96 Stage IIIA/ China Stage III Nonroad	
Rated Engine RPM	2000		1800		2000	
No. of Cylinders	4		6		6	
Bore	105 mm	4.1"	105 mm	4.1"	105 mm	4.1"
Stroke	127 mm	5"	127 mm	5"	135 mm	5.3"
Displacement	4.4 L	269 in³	6.6 L	403 in³	7.01 L	428 in³
Max. Implement Hydraulic Pump Output at Rated RPM	220+80 L/min	58+21 gpm	290+112 L/min	76+29 gpm	290+112 L/min	76+29 gpm
Tires — standard	10.00-20 dual pneumatic		10.00-20 dual pneumatic		10.00-20 dual pneumatic	
— optional	10.00-20 dual solid rubber		10.00-20 dual solid rubber		10.00-20 dual solid rubber	
	11.00-20 dual pneumatic		445/70 R19.5 TL XF		11.00-20 dual pneumatic	
	445/70/R19.5 TL XF single pneumatic		11.00-20 dual pneumatic		445/70/R19.5 TL XF single pneumatic	
Maximum Drawbar Pull	102 kN	22,931 lbf	103 kN	23,155 lbf	103 kN	23,155 lbf
Maximum Travel Speed	34 km/h	21 mph	37 km/h	23 mph	37 km/h	23 mph
Wheel Base	2550 mm	8'4"	2600 mm	8'6"	2600 mm	8'6"
Width Over Tires**	2550 mm	8'4"	2550 mm	8'4"	2550 mm	8'4"
Ground Clearance**	370 mm	14.7"	370 mm	1'3"	370 mm	14.7"
Fuel Tank Refill Capacity	235 L	62 U.S. gal	385 L	102 U.S. gal	385 L	102 U.S. gal
Hydraulic System (includes tank)	220 L	58 U.S. gal	255 L	67 U.S. gal	255 L	67 U.S. gal

*Machine weight with medium stick, heavy counterweight, bucket, full fuel tank, and 75 kg (165 lb) operator.

**Tire pressure is 750 kPa (100 psi) with standard tires.

NOTE: Specifications also vary by Sales area.
Contact your Cat dealer for details.

MODEL	M322D		M322D2	
Region Offerings	North America, Australia, New Zealand		Africa, Middle East, CIS, China, Asia Pacific, South America	
Engine Power:				
ISO 9249	123 kW	165 hp	123 kW	165 hp
ISO 14396	129 kW	173 hp	129 kW	173 hp
Operating Weight*	20 500-22 500 kg	45,195-49,604 lb	20 500-22 500 kg	45,195-49,604 lb
Bucket Capacity Range (heaped)	0.44-1.57 m ³	0.58-2.05 yd³	0.44-1.57 m ³	0.58-2.05 yd³
Engine Model	C6.6 ACERT		C7.1 ACERT	
Emission Standards	Tier 3/Stage IIIA/UN/ECE R96 Stage IIIA		Tier 3/Stage IIIA Equivalent UN/ECE R96 Stage IIIA/ China Stage III Nonroad	
Rated Engine RPM	2000		2000	
No. of Cylinders	6		6	
Bore	105 mm	4.1"	105 mm	4.1"
Stroke	127 mm	5"	135 mm	5.3"
Displacement	6.6 L	403 in³	7.01 L	428 in³
Max. Implement Hydraulic Pump Output at Rated RPM	350+112 L/min	92+29 gpm	350+112 L/min	92+29 gpm
Tires — standard	11.00-20 dual pneumatic		11.00-20 dual pneumatic	
— optional	11.00-20 dual solid rubber		11.00-20 dual solid rubber	
Maximum Drawbar Pull	127 kN	28,551 lbf	127 kN	28,551 lbf
Maximum Travel Speed	25 km/h	15 mph	25 km/h	15 mph
Wheel Base	2750 mm	9'0"	2750 mm	9'0"
Width Over Tires**	2750 mm	9'0"	2750 mm	9'0"
Ground Clearance**	380 mm	15"	380 mm	15"
Fuel Tank Refill Capacity	385 L	102 U.S. gal	385 L	102 U.S. gal
Hydraulic System (includes tank)	350 L	92.5 U.S. gal	350 L	92 U.S. gal

*Machine weight with medium stick, heavy counterweight, bucket, full fuel tank, and 75 kg (165 lb) operator.

**Tire pressure is 750 kPa (100 psi) with standard tires.

NOTE: Specifications also vary by Sales area.

Contact your Cat dealer for details.

MODEL	M314F		M316F		M318F	
Region Offerings	Europe, North America, Australia, New Zealand		Europe, North America, Australia, New Zealand		Europe, North America, Australia, New Zealand	
Engine Power:						
ISO 9249	105 kW	141 hp	105 kW	141 hp	126 kW	169 hp
ISO 14396	110 kW	148 hp	110 kW	148 hp	129.4 kW	174 hp
Operating Weight*	14 200- 16 400 kg	31,306- 36,156 lb	16 100- 18 500 kg	35,494- 40,785 lb	16 900- 36 817 kg	19,700- 42,549 lb
Bucket Capacity Range (heaped)	0.18-0.92 m ³ 0.24-1.2 yd³		0.38-1.26 m ³ 0.5-1.65 yd³		0.35-1.09 m ³ 0.46-1.43 yd³	
Engine Model	C4.4 ACERT		C4.4 ACERT		C7.1 ACERT	
Emission Standards	Tier 4 Final/Stage IV/ Japan 2014 (Tier 4 Final)		Tier 4 Final/Stage IV/ Japan 2014 (Tier 4 Final)		Tier 4 Final/Stage IV/ Japan 2014 (Tier 4 Final)	
Rated Engine RPM	2000		2000		1750	
No. of Cylinders	4		4		6	
Bore	105 mm	4.1"	105 mm	4.1"	105 mm	4.1"
Stroke	127 mm	5.0"	127 mm	5.0"	135 mm	5.3"
Displacement	4.40 L	269 in³	4.40 L	269 in³	7.01 L	428 in³
Max. Implement Hydraulic Pump Output at Rated RPM	190+80 L/min	50+21 gpm	220+80 L/min	58+21 gpm	252+85 L/min	67+22 gpm
Tires — standard	10.00-20 dual pneumatic		10.00-20 dual pneumatic		10.00-20 dual pneumatic	
— optional	11.00-20 dual pneumatic 445/70/R19.5 TL XF single pneumatic		11.00-20 dual pneumatic 445/70/R19.5 TL XF single pneumatic		10.00-20 dual solid rubber 11.00-20 dual pneumatic 445/70/R19.5 TL XF single pneumatic	
Maximum Drawbar Pull	71 kN	15,961 lbf	102 kN	22,931 lbf	103 kN	23,155 lbf
Maximum Travel Speed	37 km/h	23 mph	34 km/h	21 mph	35 km/h	22 mph
Wheel Base	2500 mm	8'2"	2550 mm	8'4"	2600 mm	8'6"
Width Over Tires**	2550 mm	8'4"	2550 mm	8'4"	2550 mm	8'4"
Ground Clearance**	370 mm	14.7"	370 mm	14.7"	370 mm	14.7"
Fuel Tank Refill Capacity	275 L	73 U.S. gal	325 L	86 U.S. gal	325 L	86 U.S. gal
DEF Tank Refill Capacity	19 L	5 U.S. gal	19 L	5 U.S. gal	35 L	9.2 U.S. gal
Hydraulic System (includes tank)	149 L	39 U.S. gal	199 L	53 U.S. gal	210 L	56 U.S. gal

*Machine weight with medium stick, heavy counterweight, bucket, full fuel tank, and 75 kg (165 lb) operator.

**Tire pressure is 750 kPa (100 psi) with standard tires.

NOTE: Specifications also vary by Sales area.
Contact your Cat dealer for details.

MODEL	M320F		M322F	
Region Offerings	Europe, North America, Australia, New Zealand		Europe, North America, Australia, New Zealand	
Engine Power:				
ISO 9249	126 kW	169 hp	126 kW	169 hp
ISO 14396	129.4 kW	174 hp	129.4 kW	174 hp
Operating Weight*	18 500-20 650 kg	40,785-46,385 lb	20 700-24 100 kg	45,635-53,131 lb
Bucket Capacity Range (heaped)	0.35-1.18 m ³	0.46-1.54 yd³	0.44-1.57 m ³	0.58-2.05 yd³
Engine Model	C7.1 ACERT		C7.1 ACERT	
Emission Standards	Tier 4 Final/Stage IV/ Japan 2014 (Tier 4 Final)		Tier 4 Final/Stage IV/ Japan 2014 (Tier 4 Final)	
Rated Engine RPM	1550		1700	
No. of Cylinders	6		6	
Bore	105 mm	4.1"	105 mm	4.1"
Stroke	135 mm	5.3"	135 mm	5.3"
Displacement	7.01 L	428 in³	7.01 L	428 in³
Max. Implement Hydraulic Pump Output at Rated RPM	294+110 L/min	78+29 gpm	357+120 L/min	94+32 gpm
Tires — standard	10.00-20 dual pneumatic		11.00-20 dual pneumatic	
— optional	10.00-20 dual solid rubber		11.00-20 dual solid rubber	
	11.00-20 dual pneumatic			
	445/70/R19.5TL XF single pneumatic			
Maximum Drawbar Pull	103 kN	23,155 lbf	127 kN	28,551 lbf
Maximum Travel Speed	35 km/h	22 mph	30 km/h	19 mph
Wheel Base	2600 mm	8'6"	2750 mm	9'0"
Width Over Tires**	2550 mm	8'4"	2750 mm	9'0"
Ground Clearance**	370 mm	14.7"	380 mm	15"
Fuel Tank Refill Capacity	415 L	110 U.S. gal	415 L	110 U.S. gal
DEF Tank Refill Capacity	35 L	9.2 U.S. gal	35 L	9.2 U.S. gal
Hydraulic System (includes tank)	240 L	63 U.S. gal	352 L	93 U.S. gal

*Machine weight with medium stick, heavy counterweight, bucket, full fuel tank, and 75 kg (165 lb) operator.

**Tire pressure is 750 kPa (100 psi) with standard tires.

NOTE: Specifications also vary by Sales area.

Contact your Cat dealer for details.

MODEL	320D2		320D2 GC		320D2 GC	
Region Offerings	Asia Pacific, China, Latin America		South America, Middle East, Africa, CIS, Asia Pacific		China	
Engine Power:					N/A	
ISO 9249	98 kW	131 hp	84 kW	112 hp		
SAE J1349	N/A		88.4 kW	119 hp	80 kW	107 hp
Operating Weight*	21 040-21 690 kg	46,390-47,820 lb	20 000-20 700 kg	44,100-45,600 lb	20 000-20 600 kg	44,100-45,400 lb
Bucket Capacity Range (heaped)	1.0-1.56 m ³ 1.3-2.04 yd ³		0.9-1.0 m ³ 1.17-1.3 yd ³		0.9 m ³ 1.17 yd ³	
Engine Model	C7.1		3054CA		C4.4	
Emission Standards	Tier 2/Stage II/ China Stage II Nonroad Equivalent		Tier 2/Stage II/ China Stage II Nonroad Equivalent		Tier 3/Stage III/ China Stage III Nonroad Equivalent	
Rated Engine RPM	1700		1800		1800	
No. of Cylinders	6		4		4	
Bore	105 mm	4.1"	—		105 mm	4.13"
Stroke	135 mm	5.3"	—		127 mm	5.00"
Displacement	7.01 L	428 in ³	4.4 L	269 in ³	4.4 L	269 in ³
Max. Implement Hydraulic Pump Output at Rated RPM	2 × 202 L/min	2 × 53.36 gpm	2 × 214 L/min	2 × 56.55 gpm	2 × 214 L/min	2 × 56.55 gpm
Relief Valve Settings:						
Implement Circuits	35 000 kPa	5076 psi	35 MPa	5076 psi	35 000 kPa	5076 psi
Travel Circuits	35 000 kPa	5076 psi	35 MPa	5076 psi	35 000 kPa	5076 psi
Swing Circuits	25 000 kPa	3626 psi	25 Mpa	3626 psi	25 000 kPa	3626 psi
Pilot Circuits	3900 kPa	566 psi	3900 kPa	566 psi	3900 kPa	566 psi
Maximum Drawbar Pull	205 kN	46,086 lbf	206 kN	46,311 lbf	206 kN	46,311 lbf
Maximum Travel Speed at Rated RPM	5.4 km/h	3.3 mph	5.8 km/h	3.6 mph	5.8 km/h	3.6 mph
Width of Standard Track Shoe	600 mm	2'0"	600 mm	2'0"	600 mm	2'0"
Overall Track Length	4080 mm	13'5"	4080 mm	13'5"	4080 mm	13'5"
Ground Contact Area with Std. Shoe	4.3 m ²	6600 in ²	4.3 m ²	6600 in ²	4.3 m ²	6600 in ²
Track Gauge	2200 mm	7'3"	2200 mm	7'3"	2200 mm	7'3"
Fuel Tank Refill Capacity	410 L	108.3 U.S. gal	410 L	108.3 U.S. gal	410 L	108.3 U.S. gal
Hydraulic System (includes tank)	260 L	68.7 U.S. gal	260 L	68.7 U.S. gal	260 L	68.7 U.S. gal

*Operating weight includes coolant, lubricants, full fuel tank, standard shoes, bucket and operator 75 kg (165 lb).

NOTE: Certain models may not be available in all Sales areas.

Specifications also vary by Sales area.

Contact your Cat dealer for details.

MODEL	320D2 L		320E		320E L	
Region Offerings	Africa, Middle East, Asia Pacific, China, Latin America		Japan, Europe		North America, Australia, New Zealand	
Engine Power:					N/A	
ISO 9249	98 kW	131 hp	114 kW	153 hp		
SAE J1349	N/A		107 kW	144 hp	114 kW	153 hp
Operating Weight*	21 680- 22 390 kg	47,800- 49,360 lb	21 700- 24 700 kg	47,840- 54,500 lb	21 500- 24 730 kg	47,400- 54,450 lb
Bucket Capacity Range (heaped)	1.0-1.56 m ³	1.3-2.04 yd ³	0.8-1.0 m ³	1.05-1.31 yd ³	0.55-1.59 m ³	0.72-2.08 yd ³
Engine Model	C7.1		C6.6 ACERT		C6.6 ACERT	
Emission Standards	Tier 2/Stage II/ China Stage II Nonroad Equivalent		Stage IIIB/Japan 2011 (Tier 4 Interim) Equivalent		Tier 4 Interim Equivalent	
Rated Engine RPM	1700		1800		1800	
No. of Cylinders	6		6		6	
Bore	105 mm	4.1"	105 mm	4.1"	105 mm	4.1"
Stroke	135 mm	5.3"	127 mm	5.0"	127 mm	5.0"
Displacement	7.01 L	428 in ³	6.6 L	403 in ³	6.6 L	403 in ³
Max. Implement Hydraulic Pump Output at Rated RPM	2 × 202 L/min	2 × 53.36 gpm	428 L/min	113.1 gpm	428 L/min	113.1 gpm
Relief Valve Settings:						
Implement Circuits	35 000 kPa	5076 psi	35 000 kPa	5076 psi	35 000 kPa	5076 psi
Heavy Lift	—		38 000 kPa	5511 psi	38 000 kPa	5511 psi
Travel Circuits	35 000 kPa	5076 psi	35 000 kPa	5076 psi	35 000 kPa	5076 psi
Swing Circuits	25 000 kPa	3626 psi	25 000 kPa	3626 psi	25 000 kPa	3626 psi
Pilot Circuits	3900 kPa	566 psi	3920 kPa	569 psi	3920 kPa	569 psi
Maximum Drawbar Pull	205 kN	46,086 lbf	205 kN	46,086 lbf	205 kN	46,086 lbf
Maximum Travel Speed at Rated RPM	5.4 km/h	3.3 mph	5.6 km/h	3.5 mph	5.6 km/h	3.5 mph
Width of Standard Track Shoe	600 mm	2'0"	600 mm	24"	790 mm	31"
Overall Track Length	4460 mm	14'8"	4075 mm	14'7"	4460 mm	14'6"
Ground Contact Area with Std. Shoe	4.7 m ²	7285 in ²	4.3 m ²	6600 in ²	6.2 m ²	9600 in ²
Track Gauge	2380 mm	7'10"	2200 mm	7'3"	2380 mm	7'10"
Fuel Tank Refill Capacity	410 L	108.3 U.S. gal	410 L	108.3 U.S. gal	410 L	108.3 U.S. gal
Hydraulic System (includes tank)	260 L	68.7 U.S. gal	260 L	68.7 U.S. gal	260 L	68.7 U.S. gal

*Operating weight includes coolant, lubricants, full fuel tank, standard shoes, bucket and operator 75 kg (165 lb).

NOTE: Certain models may not be available in all Sales areas.

Specifications also vary by Sales area.

Contact your Cat dealer for details.

MODEL	320E L		320E LRR		320E LRR	
Region Offerings	Europe		North America, Australia, New Zealand		Europe	
Engine Power:						
ISO 9249	107 kW	144 hp	N/A		105 kW	141 hp
SAE J1349	N/A		114 kW	153 hp	N/A	
Operating Weight*	21 700- 23 500 kg	47,840- 51,800 lb	23 700- 25 600 kg	52,250- 56,440 lb	23 600- 24 000 kg	52,000- 52,900 lb
Bucket Capacity Range (heaped)	0.46-1.43 m ³	0.6-1.87 yd ³	0.55-1.59 m ³	0.72-2.08 yd ³	0.46-1.43 m ³	0.6-1.87 yd ³
Engine Model	C6.6 ACERT		C6.6 ACERT		C6.6 ACERT	
Emission Standards	Stage IIIB Equivalent		Tier 4 Interim Equivalent		Stage IIIB Equivalent	
Rated Engine RPM	1800		1800		1800	
No. of Cylinders	6		6		6	
Bore	105 mm	4.1"	105 mm	4.1"	105 mm	4.1"
Stroke	127 mm	5.0"	127 mm	5.0"	127 mm	5.0"
Displacement	6.6 L	403 in ³	6.6 L	403 in ³	6.6 L	403 in ³
Max. Implement Hydraulic Pump Output at Rated RPM	428 L/min	113.1 gpm	428 L/min	113.1 gpm	428 L/min	113.1 gpm
Relief Valve Settings:						
Implement Circuits	35 000 kPa	5076 psi	35 000 kPa	5076 psi	35 000 kPa	5076 psi
Heavy Lift	38 000 kPa	5511 psi	38 000 kPa	5511 psi	38 000 kPa	5511 psi
Travel Circuits	35 000 kPa	5076 psi	35 000 kPa	5076 psi	35 000 kPa	5076 psi
Swing Circuits	25 000 kPa	3626 psi	25 000 kPa	3626 psi	25 000 kPa	3626 psi
Pilot Circuits	3920 kPa	569 psi	3920 kPa	569 psi	3920 kPa	569 psi
Maximum Drawbar Pull	205 kN	46,086 lbf	205 kN	46,086 lbf	205 kN	46,086 lbf
Maximum Travel Speed at Rated RPM	5.6 km/h	3.5 mph	5.6 km/h	3.5 mph	5.6 km/h	3.5 mph
Width of Standard Track Shoe	600 mm	24"	790 mm	31"	600 mm	24"
Overall Track Length	4460 mm	14'6"	4460 mm	14'7"	4460 mm	14'7"
Ground Contact Area with Std. Shoe	4.7 m ²	7300 in ²	6.2 m ²	9600 in ²	4.7 m ²	7300 in ²
Track Gauge	2380 mm	7'10"	2380 mm	7'10"	2380 mm	7'10"
Fuel Tank Refill Capacity	410 L	108.3 U.S. gal	290 L	76.6 U.S. gal	290 L	76.6 U.S. gal
Hydraulic System (includes tank)	260 L	68.7 U.S. gal	205 L	54.2 U.S. gal	205 L	54.2 U.S. gal

*Operating weight includes coolant, lubricants, full fuel tank, standard shoes, bucket and operator 75 kg (165 lb).

NOTE: Certain models may not be available in all Sales areas.

Specifications also vary by Sales area.
Contact your Cat dealer for details.

MODEL	320F L		323D2 L		323E L	
Region Offerings	North America		Africa, Middle East, China, Latin America		Europe	
Engine Power:	N/A		110 kW	149 hp	114 kW	153 hp
ISO 9249			N/A		N/A	
SAE J1349	120 kW	161 hp				
Operating Weight*	21 600- 22 300 kg	47,600- 49,200 lb	21 990- 23 300 kg	48,480- 51,370 lb	22 900- 25 200 kg	50,500- 55,500 lb
Bucket Capacity Range (heaped)	0.55-1.59 m ³	0.72-2.08 yd ³	1.0-1.76 m ³	1.3-2.3 yd ³	0.46-1.43 m ³	0.60-1.87 yd ³
Engine Model	C4.4 ACERT		C7.1		C6.6 ACERT	
Emission Standards	Tier 4 Final		Tier 2/Stage II/ China Stage II Nonroad Equivalent		Stage IIIB Equivalent	
Rated Engine RPM	1800		1800		1800	
No. of Cylinders	4		6		6	
Bore	105 mm	4.13"	105 mm	4.13"	105 mm	4.13"
Stroke	127 mm	5.00"	135 mm	5.31"	127 mm	5.0"
Displacement	4.4 L	269 in ³	7.01 L	428 in ³	6.6 L	403 in ³
Max. Implement Hydraulic Pump Output at Rated RPM	2 × 214 L/min	2 × 111.3 gpm	2 × 214 L/min	2 × 56.5 gpm	428 L/min	113.1 gpm
Relief Valve Settings:						
Implement Circuits	35 000 kPa	5076 psi	35 000 kPa	5076 psi	35 000 kPa	5076 psi
Heavy Lift	—		—		38 000 kPa	5511 psi
Travel Circuits	35 000 kPa	5076 psi	35 000 kPa	5076 psi	35 000 kPa	5076 psi
Swing Circuits	25 000 kPa	3626 psi	25 000 kPa	3626 psi	25 000 kPa	3626 psi
Pilot Circuits	3920 kPa	569 psi	3920 kPa	569 psi	3920 kPa	569 psi
Maximum Drawbar Pull	205 kN	46,086 lbf	205 kN	46,086 lbf	205 kN	46,086 lbf
			Two Speed Travel			
Maximum Travel Speed at Rated RPM	5.6 km/h	3.5 mph	Lo: 3.5 km/h Hi: 5.6 km/h	2.1 mph 3.5 mph	5.6 km/h	3.5 mph
Width of Standard Track Shoe	790 mm	31"	600 mm	2'0"	600 mm	24"
Overall Track Length	4460 mm	14'8"	4455mm	14'7"	4460 mm	14'7"
Ground Contact Area with Std. Shoe	6.2 m ²	9600 in ²	4.7 m ²	7300 in ²	4.7 m ²	7300 in ²
Track Gauge	2380 mm	7'10"	2380 mm	7'1"	2380 mm	7'1"
Fuel Tank Refill Capacity	410 L	108.3 U.S. gal	410 L	108 U.S. gal	410 L	108 U.S. gal
Hydraulic System (includes tank)	260 L	68.7 U.S. gal	260 L	68.7 U.S. gal	260 L	68.7 U.S. gal

*Operating weight includes coolant, lubricants, full fuel tank, standard shoes, bucket and operator 75 kg (165 lb).

NOTE: Certain models may not be available in all Sales areas.

Specifications also vary by Sales area.

Contact your Cat dealer for details.

MODEL	323E LN		323E SA		323F L	
Region Offerings	Europe		Europe		North America, Europe	
Engine Power:						
ISO 9249	114 kW	153 hp	114 kW	153 hp	120 kW	161 hp
SAE J1349	N/A		N/A		120 kW	161 hp
Operating Weight*	23 280- 24 230 kg	51,300- 53,400 lb	24 170- 25 230 kg	53,300- 55,600 lb	23 100 kg	50,900 lb
Bucket Capacity Range (heaped)	0.46-1.43 m ³	0.60-1.87 yd³	0.46-1.43 m ³	0.60-1.87 yd³	0.55-1.59 m ³	0.72-2.08 yd³
Engine Model	C6.6 ACERT		C6.6 ACERT		C7.1	
Emission Standards	Stage IIIB Equivalent		Stage IIIB Equivalent		Tier 4 Final/Stage IV	
Rated Engine RPM	1800		1800		1800	
No. of Cylinders	6		6		6	
Bore	105 mm	4.13"	105 mm	4.1"	105 mm	4.1"
Stroke	127 mm	5.0"	127 mm	5.0"	135 mm	5.3"
Displacement	6.6 L	403 in³	6.6 L	403 in³	7.1 L	433 in³
Max. Implement Hydraulic Pump Output at Rated RPM	428 L/min	113.1 gpm	428 L/min	113.1 gpm	2 x 212 L/min	2 x 56 gpm
Relief Valve Settings:						
Implement Circuits	35 000 kPa	5076 psi	35 000 kPa	5076 psi	35 000 kPa	5076 psi
Heavy Lift	38 000 kPa	5511 psi	38 000 kPa	5511 psi	38 000 kPa	5511 psi
Travel Circuits	35 000 kPa	5076 psi	35 000 kPa	5076 psi	35 000 kPa	5076 psi
Swing Circuits	25 000 kPa	3626 psi	25 000 kPa	3626 psi	25 500 kPa	3698 psi
Pilot Circuits	3920 kPa	569 psi	3920 kPa	569 psi	3920 kPa	569 psi
Maximum Drawbar Pull	205 kN	46,086 lbf	190 kN	42,700 lbf	205 kN	46,060 lbf
Maximum Travel Speed at Rated RPM	5.6 km/h	3.5 mph	5.9 km/h	3.7 mph	5.5 km/h	3.4 mph
Width of Standard Track Shoe	500 mm	20"	550 mm	22"	790 mm	31"
Overall Track Length	4460 mm	14'7"	4360 mm	14'4"	4460 mm	14'8"
Ground Contact Area with Std. Shoe	3.9 m ²	6090 in²	4.2 m ²	6500 in²	6.2 m ²	9600 in²
Track Gauge	2000 mm	6'7"	1900 mm	6'3"	2380 mm	7'10"
Fuel Tank Refill Capacity	310 L	81.9 U.S. gal	310 L	81.9 U.S. gal	410 L	108.3 U.S. gal
Hydraulic System (includes tank)	260 L	68.7 U.S. gal	260 L	68.7 U.S. gal	159 L	42 U.S. gal

*Operating weight includes coolant, lubricants, full fuel tank, standard shoes, bucket and operator 75 kg (165 lb).

NOTE: Certain models may not be available in all Sales areas.

Specifications also vary by Sales area.

Contact your Cat dealer for details.

MODEL	324E		324E L	
Region Offerings	Japan		North America, Europe, Japan, Australia, New Zealand	
Engine Power:				
ISO 9249	142 kW	190 hp	145 kW	194 hp
SAE J1349	N/A		145 kW	194 hp
Operating Weight*	24 750-25 430 kg	54,564-56,064 lb	25 127-26 307 kg	55,396-57,997 lb
Bucket Capacity Range (heaped)	1.0-1.4 m ³	1.3-1.8 yd ³	0.45-2.12 m ³	0.6-2.8 yd ³
Engine Model	C7.1 ACERT		C7.1 ACERT	
Emission Standards	Japan 2011 (Tier 4 Interim) Equivalent		Tier 4 Interim/Stage IIIB/ Japan 2011 (Tier 4 Interim) Equivalent	
Rated Engine RPM	1800		1800	
No. of Cylinders	6		6	
Displacement	7.01 L	428 in ³	7.01 L	428 in ³
Max. Implement Hydraulic Pump Output at Rated RPM	2 x 231 L/min	2 x 61 gpm	2 x 231 L/min	2 x 61 gpm
Relief Valve Settings:				
Implement Circuits	35 000 kPa	5076 psi	35 000 kPa	5076 psi
Travel Circuits	35 000 kPa	5076 psi	35 000 kPa	5076 psi
Swing Circuits	24 500 kPa	3553 psi	24 497 kPa	3553 psi
Pilot Circuits	3920 kPa	569 psi	3920 kPa	569 psi
Maximum Drawbar Pull	226 kN	50,807 lbf	227 kN	51,032 lbf
Maximum Travel Speed at Rated RPM	5.3 km/h	3.3 mph	5.3 km/h	3.3 mph
Width of Standard Track Shoe	600 mm	2'0"	800 mm	2'8"
Overall Track Length	4260 mm	13'1"	4640 mm	15'3"
Ground Contact Area with Std. Shoe	4.5 m ²	6950 in ²	4.5 m ²	6950 in ²
Track Gauge	2390 mm	7'10"	2590 mm	8'6"
Fuel Tank Refill Capacity	520 L	137 U.S. gal	520 L	137.37 U.S. gal
Hydraulic System (includes tank)	280 L	75.3 U.S. gal	280 L	75.29 U.S. gal

*Operating weight includes coolant, lubricants, full fuel tank, standard shoes, bucket and operator 75 kg (165 lb).

NOTE: Certain models may not be available in all Sales areas.

Specifications also vary by Sales area.
Contact your Cat dealer for details.

MODEL	324E LN		325F L		326D2 L	
Region Offerings	Europe		North America, Europe, Australia, New Zealand		South America, Middle East, Africa, CIS, Asia Pacific, China	
Engine Power:						
ISO 9249	145 kW	194 hp	120 kW	161 hp	141 kW	189 hp
SAE J1349	N/A		120 kW	161 hp	N/A	
Operating Weight*	25 127- 29 659 kg	55,390- 65,386 lb	25 349- 26 364 kg	55,885- 58,123 lb	24 815- 26 345 kg	54,710- 58,080 lb
Bucket Capacity Range (heaped)	1.3-2.12 m ³	1.7-2.8 yd³	0.8-1.7 m ³	1.05-2.2 yd³	0.5-2.3 m ³	0.65-3.01 yd³
Engine Model	C7.1 ACERT		C4.4 TTA		C7.1	
Emission Standards	Stage IIIB Equivalent		Tier 4 Final/Stage IV		Tier 2/Stage II/ China Stage II Nonroad Equivalent OR Tier 3/Stage IIIA/ China Stage III Nonroad Equivalent	
Rated Engine RPM	1800		1800		1800	
No. of Cylinders	6		4		6	
Bore	—		105 mm	4"	—	
Stroke	—		127 mm	5"	—	
Displacement	7.01 L	428 in³	4.4 L	269 in³	7.01 L	428 in³
Max. Implement Hydraulic Pump Output at Rated RPM	2 x 231 L/min	2 x 61 gpm	2 x 214.4 L/min	2 x 56.6 gpm	2 x 247 L/min	2 x 65.2 gpm
Relief Valve Settings:						
Implement Circuits	35 000 kPa	5076 psi	35 000 kPa	5075 psi	35 MPa	5076.4 psi
Travel Circuits	35 000 kPa	5076 psi	35 000 kPa	5075 psi	35 MPa	5076.4 psi
Swing Circuits	24 497 kPa	3553 psi	25 500 kPa	3698 psi	24.5 MPa	3555.9 psi
Pilot Circuits	3920 kPa	569 psi	4100 kPa	595 psi	3920 kPa	586.6 psi
Maximum Drawbar Pull	226 kN	50,807 lbf	203 kN	45,591 lbf	227 kN	51,032 lbf
Maximum Travel Speed at Rated RPM	5.3 km/h	3.3 mph	Two Speed Travel		5.8 km/h	3.6 mph
			Lo: 3.5 km/h	2.2 mph		
			Hi: 5.6 km/h	3.5 mph		
Width of Standard Track Shoe	790 mm	31"	790 mm	31"	790 mm	31"
Overall Track Length	4640 mm	15'3"	4460 mm	14'8"	4630 mm	15'2"
Ground Contact Area with Std. Shoe	6.5 m ²	10,100 in²	6.21 m ²	9623 in²	6.5 m ²	10,100 in²
Track Gauge	2390 mm	7'1"	3170 mm	10'5"	2590 mm	8'6"
Fuel Tank Refill Capacity	520 L	137 U.S. gal	310 L	81.9 U.S. gal	520 L	137.4 U.S. gal
Hydraulic System (includes tank)	280 L	75.3 U.S. gal	280 L	74.0 U.S. gal	285 L	75.3 U.S. gal

*Operating weight includes coolant, lubricants, full fuel tank, standard shoes, bucket and operator 75 kg (165 lb).

NOTE: Certain models may not be available in all Sales areas.

Specifications also vary by Sales area.

Contact your Cat dealer for details.

MODEL	326F		326F L		326F LN	
Region Offerings	Japan		Japan, Europe, North America		Europe	
Engine Power:						
ISO 9249	149 kW	203 hp	149 kW	203 hp	149 kW	203 hp
SAE J1349	149 kW	203 hp	149 kW	203 hp	149 kW	203 hp
Operating Weight*	24 878- 29 407 kg	54,847- 64,831 lb	24 878- 29 407 kg	54,847- 64,831 lb	24 784- 29 702 kg	54,637- 65,479 lb
Bucket Capacity Range (heaped)	1.0-1.4 m ³	1.3-1.8 yd³	1.3-2.12 m ³	1.7-2.8 yd³	1.3-2.12 m ³	1.7-2.8 yd³
Engine Model	C7.1 ACERT		C7.1 ACERT		C7.1	
Emission Standards	Japan 2014 (Tier 4 Final)		Tier 4 Final/Stage IV/ Japan 2014 (Tier 4 Final)		Stage IV	
Rated Engine RPM	1800		1800		1800	
No. of Cylinders	6		6		6	
Displacement	7.01 L	428 in³	7.01 L	428 in³	7.01 L	428 in³
Max. Implement Hydraulic Pump Output at Rated RPM	2 x 253.5 L/min	2 x 67 gpm	2 x 253.5 L/min	2 x 67 gpm	2 x 254 L/min	2 x 67 gpm
Relief Valve Settings:						
Implement Circuits	35 000 kPa	5076 psi	35 000 kPa	5076 psi	35 000 kPa	5076 psi
Travel Circuits	37 000 kPa	5366 psi	37 000 kPa	5366 psi	35 000 kPa	5076 psi
Swing Circuits	27 400 kPa	3973 psi	27 400 kPa	3973 psi	27 400 kPa	3974 psi
Pilot Circuits	4100 kPa	595 psi	4100 kPa	595 psi	2500 kPa	363 psi
Maximum Drawbar Pull	226 kN	50,807 lbf	226 kN	50,807 lbf	226 kN	50,807 lbf
Maximum Travel Speed at Rated RPM	5.3 km/h	3.3 mph	5.3 km/h	3.3 mph	5.3 km/h	3.3 mph
Width of Standard Track Shoe	600 mm	2'0"	600 mm	2'0"	790 mm	31"
Overall Track Length	4641 mm	15'3"	4641 mm	15'3"	4641 mm	15'3"
Ground Contact Area with Std. Shoe	4.5 m ²	6950 in²	4.5 m ²	6950 in²	6.5 m ²	10,100 in²
Track Gauge	2390 mm	7'10"	2590 mm	8'6"	2390 mm	7'10"
Fuel Tank Refill Capacity	520 L	137.4 U.S. gal	520 L	137.4 U.S. gal	520 L	137 U.S. gal
Hydraulic System (includes tank)	285 L	75.3 U.S. gal	285 L	75.3 U.S. gal	285 L	75.3 U.S. gal

*Operating weight includes coolant, lubricants, full fuel tank, standard shoes, bucket and operator 75 kg (165 lb).

NOTE: Certain models may not be available in all Sales areas.

Specifications also vary by Sales area.

Contact your Cat dealer for details.

MODEL	329E		329E L		329E LN	
Region Offerings	Japan		North America, Europe, Japan, Australia, New Zealand		Europe	
Engine Power:						
ISO 9249	170 kW	228 hp	170 kW	228 hp	173 kW	232 hp
SAE J1349	N/A		170 kW	228 hp	N/A	
Operating Weight*	27 700- 28 210 kg	61,068- 62,192 lb	29 057- 30 477 kg	64,060- 68,958 lb	28 717- 31 639 kg	63,310- 69,750 lb
Bucket Capacity Range (heaped)	1.1-1.5 m ³	1.4-2.0 yd ³	0.45-2.12 m ³	0.6-2.8 yd ³	1.5-2.12 m ³	2.0-2.8 yd ³
Engine Model	C7.1 ACERT		C7.1 ACERT		C7.1 ACERT	
Emission Standards	Japan 2011 (Tier 4 Interim) Equivalent		Tier 4 Interim/Stage IIIB/ Japan 2011 (Tier 4 Interim) Equivalent		Stage IIIB Equivalent	
Rated Engine RPM	1800		1800		1800	
No. of Cylinders	6		6		6	
Displacement	7.01 L	428 in ³	7.01 L	428 in ³	7.01 L	428 in ³
Max. Implement Hydraulic Pump Output at Rated RPM	494 L/min	130 gpm	2 x 247 L/min	2 x 65 gpm	—	
Relief Valve Settings:						
Implement Circuits	35 000 kPa	5076 psi	35 000 kPa	5076 psi	35 000 kPa	5076 psi
Travel Circuits	35 000 kPa	5076 psi	35 000 kPa	5076 psi	35 000 kPa	5076 psi
Swing Circuits	27 503 kPa	3989 psi	27 503 kPa	3989 psi	27 503 kPa	3989 psi
Pilot Circuits	3920 kPa	569 psi	3920 kPa	569 psi	3920 kPa	569 psi
Maximum Drawbar Pull	249 kN	55,977 lbf	249 kN	55,977 lbf	247 kN	55,528 lbf
Maximum Travel Speed at Rated RPM	5.1 km/h	3.2 mph	5.1 km/h	3.2 mph	5.1 km/h	3.2 mph
Width of Standard Track Shoe	700 mm	2'4"	800 mm	3'2"	600 mm	24"
Overall Track Length	4350 mm	14'3"	4860 mm	15'11"	4855 mm	15'11"
Ground Contact Area with Std. Shoe	5.31 m ²	8231 in ²	6.88 m ²	10,664 in ²	5.16 m ²	7998 in ²
Track Gauge	2390 mm	7'1"	2590 mm	8'6"	2390 mm	7'1"
Fuel Tank Refill Capacity	520 L	137 U.S. gal	520 L	137.37 U.S. gal	520 L	137.37 U.S. gal
Hydraulic System (includes tank)	310 L	81.89 U.S. gal	310 L	81.89 U.S. gal	310 L	81.89 U.S. gal

*Operating weight includes coolant, lubricants, full fuel tank, standard shoes, bucket and operator 75 kg (165 lb).

NOTE: Certain models may not be available in all Sales areas.

Specifications also vary by Sales area.

Contact your Cat dealer for details.

MODEL	330D2 L		330F		330F L	
Region Offerings	South America, Middle East, Africa, CIS, Asia Pacific, China		Japan		Japan, Europe, North America	
Engine Power:						
ISO 9249	151 kW	203 hp	175 kW	239 hp	175 kW	239 hp
SAE J1349	N/A		N/A		N/A	
Operating Weight*	27 835-30 115 kg	61,370-66,390 lb	26 894-30 747 kg	59,291-67,184 lb	28 577-30 939 kg	63,002-68,209 lb
Bucket Capacity Range (heaped)	0.57-2.35 m ³	0.78-3.08 yd ³	1.1-1.5 m ³	1.4-2.0 yd ³	0.45-2.12 m ³	0.6-2.8 yd ³
Engine Model	C7.1		C7.1 ACERT		C7.1 ACERT	
Emission Standards	Tier 2/Stage II/ China Stage II Nonroad Equivalent OR Tier 3/Stage IIIA/ China Stage III Nonroad Equivalent		Japan 2014 (Tier 4 Final)		Tier 4 Final/Stage IV/ Japan 2014 (Tier 4 Final)	
Rated Engine RPM	1800		1800		1800	
No. of Cylinders	6		6		6	
Displacement	7.01 L	428 in ³	7.01 L	428 in ³	7.01 L	428 in ³
Max. Implement Hydraulic Pump Output at Rated RPM	2 x 254 L/min	2 x 67.1 gpm	2 x 246.5 L/min	2 x 65 gpm	2 x 246.5 L/min	2 x 65 gpm
Relief Valve Settings:						
Implement Circuits	35 000 kPa	5076.4 psi	35 000 kPa	5076 psi	35 000 kPa	5076 psi
Travel Circuits	35 000 kPa	5076.4 psi	37 000 kPa	5366 psi	37 000 kPa	5366 psi
Swing Circuits	27 500 kPa	3982.7 psi	27 400 kPa	3974 psi	27 400 kPa	3974 psi
Pilot Circuits	3920 kPa	568.6 psi	4100 kPa	595 psi	4100 kPa	595 psi
Maximum Drawbar Pull	248 kN	55,752.6 lbf	247 kN	55,528 lbf	247 kN	55,528 lbf
Maximum Travel Speed at Rated RPM	5.3 km/h	3.4 mph	5.1 km/h	3.2 mph	5.1 km/h	3.2 mph
Width of Standard Track Shoe	600 mm	24"	700 mm	28"	800 mm	3'2"
Overall Track Length	4860 mm	15'11"	4860 mm	15'11"	4860 mm	15'11"
Ground Contact Area with Std. Shoe	5.2 m ²	8000 in ²	5.31 m ²	8231 in ²	6.88 m ²	10,664 in ²
Track Gauge	2590 mm	8'6"	2390 mm	7'10"	2590 mm	8'6"
Fuel Tank Refill Capacity	520 L	137.4 U.S. gal	520 L	137.4 U.S. gal	520 L	137.4 U.S. gal
Hydraulic System (includes tank)	310 L	81.9 U.S. gal	310 L	81.9 U.S. gal	310 L	81.9 U.S. gal

*Operating weight includes coolant, lubricants, full fuel tank, standard shoes, bucket and operator 75 kg (165 lb).

NOTE: Certain models may not be available in all Sales areas.

Specifications also vary by Sales area.

Contact your Cat dealer for details.

MODEL	330F LN		335F L		336D2	
Region Offerings	Europe		Japan, Europe, North America		Asia Pacific	
Engine Power:						
ISO 9249	173 kW	235 hp	170 kW	231 hp	200 kW	268 hp
SAE J1349	N/A		149 kW	200 hp	N/A	
Operating Weight*	28 293- 31 299 kg	62,372- 68,999 lb	34 735- 37 967 kg	76,578- 83,703 lb	34 489- 37 086 kg	76,035- 81,761 lb
Bucket Capacity Range (heaped)	1.5-2.12 m ³	2.0-2.8 yd³	0.52-2.15 m ³	0.68-2.81 yd³	1.4-2.0 m ³	1.83-2.49 yd³
Engine Model	C7.1 ACERT		C7.1 ACERT		C9 ACERT	
Emission Standards	Stage IV		Tier 4 Final/Stage IV/ Japan 2014 (Tier 4 Final)		Tier 2/Stage II Equivalent	
Rated Engine RPM	1800		1800		1800	
No. of Cylinders	6		6		6	
Displacement	7.01 L	428 in³	7.01 L	428 in³	8.8 L	537 in³
Max. Implement Hydraulic Pump Output at Rated RPM	2 x 246.6 L/min	2 x 65.1 gpm	2 x 246.6 L/min	2 x 65.1 gpm	2 x 265 L/min	2 x 70 gpm
Relief Valve Settings:						
Implement Circuits	35 000 kPa	5076 psi	35 000 kPa	5076 psi	35 000 kPa	5076 psi
Travel Circuits	37 000 kPa	5366 psi	37 000 kPa	5366 psi	35 000 kPa	5076 psi
Swing Circuits	27 400 kPa	3974 psi	27 400 kPa	3974 psi	28 000 kPa	4061 psi
Pilot Circuits	2500 kPa	363 psi	4100 kPa	595 psi	4000 kPa	580.2 psi
Maximum Drawbar Pull	247 kN	55,528 lbf	295 kN	66,319 lbf	300.5 kN	67,555 lbf
Maximum Travel Speed at Rated RPM	5.1 km/h	3.2 mph	4.2 km/h	2.6 mph	4.85 km/h	3.0 mph
Width of Standard Track Shoe	600 mm	24"	850 mm	33"	600 mm	24"
Overall Track Length	4855 mm	15'11"	5020 mm	16'6"	4590 mm	15'1"
Ground Contact Area with Std. Shoe	5.16 m ²	7998 in²	7.46 m ²	11,560 in²	4.7 m ²	7350 in²
Track Gauge	2390 mm	7'10"	2590 mm	8'6"	2590 mm	8'6"
Fuel Tank Refill Capacity	520 L	137.4 U.S. gal	385 L	101.7 U.S. gal	620 L	163.79 U.S. gal
DEF Tank Refill Capacity	—		154 L	40.7 U.S. gal	—	
Hydraulic System (includes tank)	310 L	82 U.S. gal	290 L	76.6 U.S. gal	410 L	108.31 U.S. gal

*Operating weight includes coolant, lubricants, full fuel tank, standard shoes, bucket and operator 75 kg (165 lb).

NOTE: Certain models may not be available in all Sales areas.

Specifications also vary by Sales area.

Contact your Cat dealer for details.

MODEL	336D2 GC		336D2 L		336D2 L	
Region Offerings	China		Asia Pacific, South America		Middle East, Africa	
Engine Power:						
ISO 9249	201 kW	270 hp	200 kW	268 hp	200 kW	268 hp
SAE J1349	201 kW	270 hp	N/A		N/A	
Operating Weight*	32 900 kg	72,500 lb	34 489- 37 086 kg	76,035- 81,761 lb	34 489- 37 086 kg	76,035- 81,761 lb
Bucket Capacity Range (heaped)	1.64 m ³	2.14 yd³	0.7-2.2 m ³	0.9-3.0 yd³	1.11-2.4 m ³	1.45-3.14 yd³
Engine Model	C9 ACERT		C9 ACERT		C9 ACERT	
Emission Standards	Tier 3/Stage IIIA/ Japan 2006 (Tier 3) Equivalent		Tier 2/Stage II Equivalent		Tier 2/Stage II Equivalent	
Rated Engine RPM	1800		1800		1800	
No. of Cylinders	6		6		6	
Bore	112 mm	4.41"	—		—	
Stroke	149 mm	5.87"	—		—	
Displacement	8.8 L	537 in³	8.8 L	537 in³	8.8 L	537 in³
Max. Implement Hydraulic Pump Output at Rated RPM	562 L/min	148 gpm	2 x 265 L/min	2 x 70 gpm	2 x 265 L/min	2 x 70 gpm
Relief Valve Settings:						
Implement Circuits	35 000 kPa	5076 psi	35 000 kPa	5076 psi	35 000 kPa	5076 psi
Travel Circuits	35 000 kPa	5076 psi	35 000 kPa	5076 psi	35 000 kPa	5076 psi
Swing Circuits	28 000 kPa	4061 psi	28 000 kPa	4061 psi	28 000 kPa	4061 psi
Pilot Circuits	4000 kPa	580 psi	4000 kPa	580.2 psi	4000 kPa	580.2 psi
Maximum Drawbar Pull	302 kN	67,780 lbf	300.5 kN	67,555 lbf	300.5 kN	67,555 lbf
	Two Speed Travel					
Maximum Travel Speed at Rated RPM	Lo: 2.9 km/h	1.8 mph	4.85 km/h	3.0 mph	4.85 km/h	3.0 mph
	Hi: 4.6 km/h	2.9 mph				
Width of Standard Track Shoe	600 mm	24"	700 mm	28"	700 mm	28"
Overall Track Length	4590 mm	15'1"	5020 mm	16'6"	5020 mm	16'6"
Ground Contact Area with Std. Shoe	4.7 m ²	7350 in²	6.1 m ²	9500 in²	6.1 m ²	9500 in²
Track Gauge	2590 mm	8'6"	2590 mm	8'6"	2590 mm	8'6"
Fuel Tank Refill Capacity	620 L	164 U.S. gal	620 L	163.79 U.S. gal	620 L	163.79 U.S. gal
Hydraulic System (includes tank)	410 L	108 U.S. gal	410 L	108.31 U.S. gal	410 L	108.31 U.S. gal

*Operating weight includes coolant, lubricants, full fuel tank, standard shoes, bucket and operator 75 kg (165 lb).

NOTE: Certain models may not be available in all Sales areas.

Specifications also vary by Sales area.

Contact your Cat dealer for details.

MODEL	336D2 XE		336D2 L XE		336E	
Region Offerings	China, S.E. Asia		S.E. Asia, South America, Africa, Middle East, CIS		Japan	
Engine Power:						
ISO 9249	208 kW	279 hp	208 kW	279 hp	224 kW	300 hp
SAE J1349	208 kW	279 hp	208 kW	279 hp	N/A	
Operating Weight*	37 000 kg	81,600 lb	37 000 kg	81,600 lb	34 500-37 200 kg	76,059-82,012 lb
Bucket Capacity Range (heaped)	0.73-2.78 m ³	0.95-3.64 yd³	0.73-2.78 m ³	0.95-3.64 yd³	1.4-2.0 m ³	1.8-2.6 yd³
Engine Model	C9 ACERT		C9 ACERT		C9.3 ACERT	
Emission Standards	Tier 3/Stage IIIA/ Japan 2006 (Tier 3) Equivalent		Tier 3/Stage IIIA/ Japan 2006 (Tier 3) Equivalent		Japan 2011 (Tier 4 Interim) Equivalent	
Rated Engine RPM	1800		1800		1800	
No. of Cylinders	6		6		6	
Bore	112 mm	4.41"	112 mm	4.41"	—	
Stroke	149 mm	5.87"	149 mm	5.87"	—	
Displacement	8.8 L	537 in³	8.8 L	537 in³	9.3 L	568 in³
Max. Implement Hydraulic Pump Output at Rated RPM	562 L/min	148 gpm	562 L/min	148 gpm	2 × 289 L/min	2 × 76.5 gpm
Relief Valve Settings:						
Implement Circuits	35 000 kPa	5076 psi	35 000 kPa	5076 psi	35 000 kPa	5076 psi
Travel Circuits	35 000 kPa	5076 psi	35 000 kPa	5076 psi	35 000 kPa	5076 psi
Swing Circuits	28 000 kPa	4061 psi	28 000 kPa	4061 psi	28 000 kPa	4061 psi
Pilot Circuits	4100 kPa	595 psi	4100 kPa	595 psi	4100 kPa	595 psi
Maximum Drawbar Pull	300 kN	67,398 lbf	300 kN	67,398 lbf	295 kN	66,319 lbf
	Two Speed Travel		Two Speed Travel			
Maximum Travel Speed at Rated RPM	Lo: 2.9 km/h	1.8 mph	Lo: 2.9 km/h	1.8 mph	5.0 km/h	3.0 mph
	Hi: 4.6 km/h	2.9 mph	Hi: 4.6 km/h	2.9 mph		
Width of Standard Track Shoe	600 mm	24"	700 mm	28"	700 mm	2'4"
Overall Track Length	4590 mm	15'1"	5020 mm	16'6"	4590 mm	15'1"
Ground Contact Area with Std. Shoe	4.74 m ²	7350 in²	6.14 m ²	9520 in²	5.53 m ²	8572 in²
Track Gauge	2590 mm	8'6"	2590 mm	8'6"	2590 mm	8'6"
Fuel Tank Refill Capacity	620 L	164 U.S. gal	620 L	164 U.S. gal	620 L	163.8 U.S. gal
Hydraulic System (includes tank)	410 L	108 U.S. gal	410 L	108 U.S. gal	380 L	100.4 U.S. gal
Hydraulic Tank	—		—		194 L	51.2 U.S. gal

*Operating weight includes coolant, lubricants, full fuel tank, standard shoes, bucket and operator 75 kg (165 lb).

NOTE: Certain models may not be available in all Sales areas.

Specifications also vary by Sales area.

Contact your Cat dealer for details.

MODEL	336E L		336E LN		336E L H	
Region Offerings	North America, Europe, Japan		Europe		North America, Europe, Japan	
Engine Power:						
ISO 9249	224 kW	300 hp	224 kW	300 hp	230 kW	308 hp
SAE J1349	224 kW	300 hp	N/A		230 kW	308 hp
Operating Weight*	36 144- 38 686 kg	79,682- 85,286 lb	36 144- 38 686 kg	79,682- 85,286 lb	36 570- 39 370 kg	80,617- 86,796 lb
Bucket Capacity Range (heaped)	0.74-3.16 m ³ 1.0-4.13 yd³		1.18-2.41 m ³ 1.54-3.15 yd³		0.74-3.16 m ³ 1.0-4.13 yd³	
Engine Model	C9.3 ACERT		C9.3 ACERT		C9.3 ACERT	
Emission Standards	Tier 4 Interim/Stage IIIB/ Japan 2011 (Tier 4 Interim) Equivalent		Stage IIIB Equivalent		Tier 4 Interim/Stage IIIB/ Japan 2011 (Tier 4 Interim) Equivalent	
Rated Engine RPM	1800		1800		1800	
No. of Cylinders	6		6		6	
Displacement	9.3 L	568 in³	9.3 L	568 in³	9.3 L	568 in³
Max. Implement Hydraulic Pump Output at Rated RPM	2 x 289 L/min	2 x 76.5 gpm	2 x 289 L/min	2 x 76.5 gpm	2 x 285 L/min	2 x 75.3 gpm
Relief Valve Settings:						
Implement Circuits	35 000 kPa	5076 psi	35 000 kPa	5076 psi	35 000 kPa	5076 psi
Travel Circuits	35 000 kPa	5076 psi	35 000 kPa	5076 psi	35 000 kPa	5076 psi
Swing Circuits	28 000 kPa	4061 psi	28 000 kPa	4061 psi	31 500 kPa	4569 psi
Pilot Circuits	4100 kPa	595 psi	4100 kPa	595 psi	4100 kPa	595 psi
Maximum Drawbar Pull	295 kN	66,319 lbf	295 kN	66,319 lbf	295 kN	66,319 lbf
Maximum Travel Speed at Rated RPM	4.9 km/h	3.0 mph	4.9 km/h	3.0 mph	4.9 km/h	3.0 mph
Width of Standard Track Shoe	850 mm	2'10"	600 mm	2'0"	850 mm	2'10"
Overall Track Length	5020 mm	16'6"	5020 mm	16'6"	5020 mm	16'6"
Ground Contact Area with Std. Shoe	7.46 m ²	11,563 in²	5.26 m ²	8153 in²	7.46 m ²	11,563 in²
Track Gauge	2590 mm	8'6"	2390 mm	7'10"	2590 mm	8'6"
Fuel Tank Refill Capacity	620 L	163.8 U.S. gal	620 L	163.8 U.S. gal	620 L	163.8 U.S. gal
Hydraulic System (includes tank)	380 L	100.4 U.S. gal	380 L	100.4 U.S. gal	380 L	100.4 U.S. gal
Hydraulic Tank	194 L	51.2 U.S. gal	194 L	51.2 U.S. gal	175 L	44.9 U.S. gal

*Operating weight includes coolant, lubricants, full fuel tank, standard shoes, bucket and operator 75 kg (165 lb).

NOTE: Certain models may not be available in all Sales areas.

Specifications also vary by Sales area.
Contact your Cat dealer for details.

MODEL	336E LN H		336F L		336F LN	
Region Offerings	Europe		North America		Europe	
Engine Power:						
ISO 9249	230 kW	308 hp	226 kW	303 hp	226 kW	303 hp
SAE J1349	N/A		N/A		226 kW	303 hp
Operating Weight*	35 400- 37 000 kg	78,042- 81,569 lb	36 500- 40 100 kg	80,500- 88,400 lb	38 900 kg	85,800 lb
Bucket Capacity Range (heaped)	1.18-2.41 m ³	1.54-3.15 yd³	0.74-3.16 m ³	1.0-4.13 yd³	0.73-2.55 m ³	0.95-3.33 yd³
Engine Model	C9.3 ACERT		C9.3 ACERT		C9.3 ACERT	
Emission Standards	Stage IIIB Equivalent		Tier 4 Final		Tier 4 Final/Stage IV/ Japan 2014 (Tier 4 Final)	
Rated Engine RPM	1800		1800		1800	
No. of Cylinders	6		6		6	
Bore	—		—		115 mm	4.53"
Stroke	—		—		149 mm	5.87"
Displacement	9.3 L	568 in³	9.3 L	568 in³	9.3 L	567 in³
Max. Implement Hydraulic Pump Output at Rated RPM	2 x 285 L/min	2 x 75.3 gpm	2 x 289 L/min	2 x 76.5 gpm	570 L/min	151 gpm
Relief Valve Settings:						
Implement Circuits	35 000 kPa	5076 psi	35 000 kPa	5076 psi	35 000 kPa	5076 psi
Travel Circuits	35 000 kPa	5076 psi	35 000 kPa	5076 psi	35 000 kPa	5076 psi
Swing Circuits	31 500 kPa	4569 psi	28 000 kPa	4061 psi	28 000 kPa	4061 psi
Pilot Circuits	4100 kPa	595 psi	4100 kPa	595 psi	4100 kPa	595 psi
Maximum Drawbar Pull	295 kN	66,319 lbf	294 kN	66,139 lbf	294 kN	66,139 lbf
					Two Speed Travel	
Maximum Travel Speed at Rated RPM	4.9 km/h	3.0 mph	4.8 km/h	3.0 mph	Lo: 3.0 km/h	1.9 mph
					Hi: 4.8 km/h	3.0 mph
Width of Standard Track Shoe	600 mm	2'0"	850 mm	2'10"	600 mm	24"
Overall Track Length	5020 mm	16'6"	5030 mm	16'6"	5030 mm	16'6"
Ground Contact Area with Std. Shoe	5.26 m ²	8153 in²	7.46 m ²	11,563 in²	5.26 m ²	8150 in²
Track Gauge	2390 mm	7'10"	2590 mm	8'6"	2390 mm	7'10"
Fuel Tank Refill Capacity	620 L	163.8 U.S. gal	620 L	164 U.S. gal	620 L	164 U.S. gal
Hydraulic System (includes tank)	380 L	100.4 U.S. gal	380 L	100 U.S. gal	380 L	100 U.S. gal
Hydraulic Tank	175 L	44.9 U.S. gal	175 L	46 U.S. gal	—	

*Operating weight includes coolant, lubricants, full fuel tank, standard shoes, bucket and operator 75 kg (165 lb).

NOTE: Certain models may not be available in all Sales areas.

Specifications also vary by Sales area.

Contact your Cat dealer for details.

MODEL	336F L XE		336F LN XE		340D2 L	
Region Offerings	North America, Europe		Europe		China, S.E. Asia, South America except Brazil, Africa, Middle East, CIS	
Engine Power:						
ISO 9249	226 kW	303 hp	226 kW	303 hp	208 kW	279 hp
SAE J1349	226 kW	303 hp	226 kW	303 hp	208 kW	279 hp
Operating Weight*	40 300 kg	88,800 lb	40 300 kg	88,800 lb	41 200 kg	90,800 lb
Bucket Capacity Range (heaped)	0.73-2.55 m ³	0.95-3.33 yd³	0.73-2.55 m ³	0.95-3.33 yd³	0.73-2.78 m ³	0.95-3.64 yd³
Engine Model	C9.3 ACERT		C9.3 ACERT		C9 ACERT	
Emission Standards	Tier 4 Final/Stage IV/ Japan 2014 (Tier 4 Final)		Tier 4 Final/Stage IV/ Japan 2014 (Tier 4 Final)		Tier 3/Stage IIIA/Japan 2006 (Tier 3) Equivalent	
Rated Engine RPM	1800		1800		1800	
No. of Cylinders	6		6		6	
Bore	115 mm	4.53"	115 mm	4.53"	112 mm	4.41"
Stroke	149 mm	5.87"	149 mm	5.87"	149 mm	5.87"
Displacement	9.3 L	567 in³	9.3 L	567 in³	8.8 L	537 in³
Max. Implement Hydraulic Pump Output at Rated RPM	570 L/min	151 gpm	570 L/min	151 gpm	562 L/min	148 gpm
Relief Valve Settings:						
Implement Circuits	35 000 kPa	5076 psi	35 000 kPa	5076 psi	35 000 kPa	5076 psi
Travel Circuits	35 000 kPa	5076 psi	35 000 kPa	5076 psi	35 000 kPa	5076 psi
Swing Circuits	31 500 kPa	4569 psi	31 500 kPa	4569 psi	28 000 kPa	4061 psi
Pilot Circuits	4100 kPa	595 psi	4100 kPa	595 psi	4100 kPa	595 psi
Maximum Drawbar Pull	294 kN	66,139 lbf	294 kN	66,139 lbf	300 kN	67,398 lbf
	Two Speed Travel		Two Speed Travel		Two Speed Travel	
Maximum Travel Speed at Rated RPM	Lo: 3.0 km/h	1.9 mph	Lo: 3.0 km/h	1.9 mph	Lo: 2.9 km/h	1.8 mph
	Hi: 4.8 km/h	3.0 mph	Hi: 4.8 km/h	3.0 mph	Hi: 4.6 km/h	2.9 mph
Width of Standard Track Shoe	850 mm	33"	600 mm	24"	600 mm	24"
Overall Track Length	5030 mm	16'6"	5030 mm	16'6"	5060 mm	16'7"
Ground Contact Area with Std. Shoe	7.46 m ²	11,560 in²	5.26 m ²	8150 in²	5.26 m ²	8150 in²
Track Gauge	2590 mm	8'6"	2390 mm	7'10"	2920 mm	9'7"
Fuel Tank Refill Capacity	620 L	164 U.S. gal	620 L	164 U.S. gal	620 L	164 U.S. gal
Hydraulic System (includes tank)	380 L	100 U.S. gal	380 L	100 U.S. gal	410 L	108 U.S. gal

*Operating weight includes coolant, lubricants, full fuel tank, standard shoes, bucket and operator 75 kg (165 lb).

NOTE: Certain models may not be available in all Sales areas.

Specifications also vary by Sales area.

Contact your Cat dealer for details.

MODEL	340F L		349D2 – FIX		349D2 L – FIX	
Region Offerings	Europe		Asia Pacific, CIS		South America, Asia Pacific, Middle East, Africa, CIS, New Zealand, Australia	
Engine Power:						
ISO 9249	228 kW	306 hp	289 kW	387 hp	289 kW	387 hp
SAE J1349	228 kW	306 hp	N/A		N/A	
Operating Weight*	43 600 kg	96,100 lb	43 570- 46 580 kg	96,055- 102,691 lb	45 382- 47 919 kg	100,100- 105,600 lb
Bucket Capacity Range (heaped)	1.64-2.41 m ³	2.14-3.16 yd³	1.0-3.1 m ³	1.3-4.03 yd³	1.0-3.1 m ³	1.3-4.03 yd³
Engine Model	C9.3 ACERT		C13 ACERT		C13 ACERT	
Emission Standards	Tier 4 Final/Stage IV/ Japan 2014 (Tier 4 Final)		Tier 2/Stage II Equivalent OR Tier 3/Stage IIIA Equivalent		Tier 2/Stage II Equivalent OR Tier 3/Stage IIIA Equivalent	
Rated Engine RPM	1800		1800		1800	
No. of Cylinders	6		6		6	
Bore	115 mm	4.53"	—		—	
Stroke	149 mm	5.87"	—		—	
Displacement	9.3 L	567 in³	12.5 L	762 in³	12.5 L	762 in³
Max. Implement Hydraulic Pump Output at Rated RPM	570 L/min	151 gpm	2 x 367 L/min	2 x 97 gpm	2 x 367 L/min	2 x 97 gpm
Relief Valve Settings:						
Implement Circuits	35 000 kPa	5076 psi	35 000 kPa	5076 psi	35 000 kPa	5076 psi
Travel Circuits	35 000 kPa	5076 psi	35 000 kPa	5076 psi	35 000 kPa	5076 psi
Swing Circuits	28 000 kPa	4061 psi	31 400 kPa	4554 psi	31 400 kPa	4554 psi
Pilot Circuits	4100 kPa	595 psi	4110 kPa	596 psi	4110 kPa	596 psi
Maximum Drawbar Pull	291 kN	66,139 lbf	338 kN	75,985 lbf	338 kN	75,985 lbf
	Two Speed Travel		Two Speed Travel		Two Speed Travel	
Maximum Travel Speed at Rated RPM	Lo: 3.0 km/h	1.9 mph	4.5 km/h	2.7 mph	Lo: 3.5 km/h	2.2 mph
	Hi: 4.8 km/h	3.0 mph			Hi: 4.5 km/h	2.7 mph
Width of Standard Track Shoe	600 mm	24"	750 mm	2'6"	600 mm	24"
Overall Track Length	5020 mm	16'6"	5070 mm	16'8"	5360 mm	17'7"
Ground Contact Area with Std. Shoe	5.26 m ²	8150 in²	6.6 m ²	10,200 in²	5.7 m ²	8800 in²
Track Gauge	2920 mm	9'7"	2740 mm	9'0"	2740 mm	9'0"
Fuel Tank Refill Capacity	620 L	164 U.S. gal	705 L	186 U.S. gal	705 L	186 U.S. gal
Hydraulic System (includes tank)	380 L	100 U.S. gal	570 L	150 U.S. gal	570 L	150 U.S. gal
Hydraulic Tank	—		243 L	64 U.S. gal	—	

*Operating weight includes coolant, lubricants, full fuel tank, standard shoes, bucket and operator 75 kg (165 lb).

NOTE: Certain models may not be available in all Sales areas.

Specifications also vary by Sales area.
Contact your Cat dealer for details.

MODEL	349E – FIX		349E L – FIX		349E L – VG	
Region Offerings	Japan		Japan, Australia, New Zealand		Japan, Australia, New Zealand	
Engine Power:						
ISO 9249	317 kW	425 hp	295 kW	396 hp	295 kW	396 hp
SAE J1349	N/A		295 kW	396 hp	N/A	
Operating Weight*	47 480- 49 590 kg	104,675- 109,327 lb	47 700- 53 300 kg	105,158- 117,504 lb	50 500- 53 300 kg	111,300- 117,500 lb
Bucket Capacity Range (heaped)	0.88-3.82 m ³ 1.15-5.0 yd³		0.88-3.82 m ³ 1.15-5.0 yd³		0.88-3.82 m ³ 1.15-5.0 yd³	
Engine Model	C13 ACERT		C13 ACERT		C13 ACERT	
Emission Standards	Tier 4 Interim/Stage IIIB/ Japan 2011 (Tier 4 Interim) Equivalent		Tier 4 Interim/Stage IIIB/ Japan 2011 (Tier 4 Interim) Equivalent		Stage IIIB/ Japan 2011 (Tier 4 Interim) Equivalent	
Rated Engine RPM	1800		1800		1800	
No. of Cylinders	6		6		6	
Displacement	12.5 L	763 in³	12.5 L	763 in³	12.5 L	763 in³
Max. Implement Hydraulic Pump Output at Rated RPM	2 x 385 L/min	2 x 102 gpm	2 x 385 L/min	2 x 102 gpm	2 x 385 L/min	2 x 102 gpm
Relief Valve Settings:						
Implement Circuits	35 000 kPa	5076 psi	35 000 kPa	5076 psi	35 000 kPa	5076 psi
Travel Circuits	35 000 kPa	5076 psi	35 000 kPa	5076 psi	35 000 kPa	5076 psi
Swing Circuits	27 500 kPa	3989 psi	27 500 kPa	3989 psi	27 500 kPa	3989 psi
Pilot Circuits	4120 kPa	598 psi	4120 kPa	598 psi	4120 kPa	598 psi
Maximum Drawbar Pull	335 kN	75,300 lbf	335 kN	75,300 lbf	335 kN	75,300 lbf
	Two Speed Travel		Two Speed Travel		Two Speed Travel	
Maximum Travel Speed at Rated RPM	Lo: 3.7 km/h	2.3 mph	Lo: 3.7 km/h	2.3 mph	Lo: 3.7 km/h	2.3 mph
	Hi: 4.7 km/h	2.9 mph	Hi: 4.7 km/h	2.9 mph	Hi: 4.7 km/h	2.9 mph
Width of Standard Track Shoe	600 mm	2'0"	900 mm	2'9"	600 mm	2'0"
Overall Track Length	5040 mm	16'6"	5370 mm	17'7"	5380 mm	17'8"
Ground Contact Area with Std. Shoe	5.26 m ²	8153 in²	8.48 m ²	13,140 in²	5.63 m ²	8726 in²
Track Gauge	2740 mm	9'0"	2740 mm	9'0"	2890 mm	9'6"
Fuel Tank Refill Capacity	720 L	190 U.S. gal	720 L	190 U.S. gal	720 L	190 U.S. gal
Hydraulic System (includes tank)	570 L	150.6 U.S. gal	570 L	150.6 U.S. gal	570 L	150.6 U.S. gal
Hydraulic Tank	407 L	107.5 U.S. gal	407 L	107.5 U.S. gal	407 L	107.5 U.S. gal

*Operating weight includes coolant, lubricants, full fuel tank, standard shoes, bucket and operator 75 kg (165 lb).

NOTE: Certain models may not be available in all Sales areas.

Specifications also vary by Sales area.

Contact your Cat dealer for details.

MODEL	349F L – FIX		349F L XE		352F – VG	
Region Offerings	North America		North America		North America	
Engine Power:						
ISO 9249	295 kW	396 hp	304 kW	408 hp	295 kW	396 hp
SAE J1349	N/A		304 kW	408 hp	N/A	
Operating Weight*	48 650- 53 300 kg	107,200- 117,500 lb	51 700 kg	114,000 lb	50 900- 53 300 kg	112,200- 117,500 lb
Bucket Capacity Range (heaped)	0.88-3.82 m ³	1.15-5.0 yd ³	0.88-3.82 m ³	1.15-5.0 yd ³	0.88-3.82 m ³	1.15-5.0 yd ³
Engine Model	C13 ACERT		C13 ACERT		C13 ACERT	
Emission Standards	Tier 4 Final/Stage IV/ Japan 2014 (Tier 4 Final)		Tier 4 Final/Stage IV/ Japan 2014 (Tier 4 Final)		Tier 4 Final/Stage IV/ Japan 2014 (Tier 4 Final)	
Rated Engine RPM	1800		1800		1800	
No. of Cylinders	6		6		6	
Bore	—		130 mm	5.1"	—	
Stroke	—		157 mm	6.2"	—	
Displacement	12.5 L	763 in ³	12.5 L	763 in ³	12.5 L	763 in ³
Max. Implement Hydraulic Pump Output at Rated RPM	2 × 385 L/min	2 × 102 gpm	750 L/min	198 gpm	2 × 385 L/min	2 × 102 gpm
Relief Valve Settings:						
Implement Circuits	35 000 kPa	5076 psi	35 000 kPa	5080 psi	35 000 kPa	5076 psi
Travel Circuits	35 000 kPa	5076 psi	35 000 kPa	5080 psi	35 000 kPa	5076 psi
Swing Circuits	27 500 kPa	3989 psi	27 500 kPa	3990 psi	27 500 kPa	3989 psi
Pilot Circuits	4120 kPa	598 psi	4120 kPa	598 psi	4120 kPa	598 psi
Maximum Drawbar Pull	335 kN	75,300 lbf	335 kN	75,300 lbf	335 kN	75,300 lbf
	Two Speed Travel		Two Speed Travel		Two Speed Travel	
Maximum Travel Speed at Rated RPM	Lo: 3.7 km/h	2.3 mph	Lo: 2.9 km/h	1.8 mph	Lo: 3.7 km/h	2.3 mph
	Hi: 4.7 km/h	2.9 mph	Hi: 4.7 km/h	2.9 mph	Hi: 4.7 km/h	2.9 mph
Width of Standard Track Shoe	900 mm	2'9"	900 mm	35"	900 mm	2'9"
Overall Track Length	5370 mm	17'7"	5370 mm	17'7"	5380 mm	17'8"
Ground Contact Area with Std. Shoe	8.48 m ²	13,140 in ²	7.89 m ²	12,230 in ²	8.45 m ²	13,100 in ²
Track Gauge	2740 mm	9'0"	2740 mm	9'0"	2890 mm	9'6"
Fuel Tank Refill Capacity	720 L	190 U.S. gal	720 L	190 U.S. gal	720 L	190 U.S. gal
Hydraulic System (includes tank)	570 L	150.6 U.S. gal	570 L	151 U.S. gal	570 L	150.6 U.S. gal
Hydraulic Tank	407 L	107.5 U.S. gal	—	—	407 L	107.5 U.S. gal

*Operating weight includes coolant, lubricants, full fuel tank, standard shoes, bucket and operator 75 kg (165 lb).

NOTE: Certain models may not be available in all Sales areas.

Specifications also vary by Sales area.
Contact your Cat dealer for details.

MODEL	352F XE		374D L		374F L	
Region Offerings	Europe		Europe, Middle East, Africa, CIS, North America, South America, Asia Pacific, Japan		World Wide	
Engine Power:						
ISO 9249	304 kW	408 hp	355 kW	476 hp	352 kW	472 hp
SAE J1349	304 kW	408 hp	355 kW	476 hp	352 kW	472 hp
Operating Weight*	54 600 kg	120,400 lb	70 959-75 596 kg	156,438-166,661 lb	70 973-75 167 kg	156,469-165,714 lb
Bucket Capacity Range (heaped)	0.88-3.82 m ³ 1.15-5.00 yd³		—		—	
Engine Model	C13 ACERT		C15 ACERT		C15 ACERT	
Emission Standards	Tier 4 Final/Stage IV/ Japan 2014 (Tier 4 Final)		Tier 2/Stage II/Japan 2001 (Tier 2) Equivalent OR Tier 3/Stage IIIA/Japan 2006 (Tier 3) Equivalent		Tier 4 Final/Stage IV/ Japan 2014 (Tier 4 Final)	
Rated Engine RPM	1800		1800		1600 (Operation) 1700 (Travel)	
No. of Cylinders	6		6		6	
Bore	130 mm	5.1"	—		—	
Stroke	157 mm	6.2"	—		—	
Displacement	12.5 L	763 in³	15.2 L	928 in³	15.2 L	928 in³
Max. Implement Hydraulic Pump Output at Rated RPM	750 L/min	198 gpm	2 x 440 L/min	2 x 116 gpm	—	
Implement Travel	—	—	—	—	2 x 448 L/min	2 x 118 gpm
	—	—	—	—	2 x 476 L/min	2 x 126 gpm
Relief Valve Settings:						
Implement Circuits	35 000 kPa	5080 psi	35 000 kPa	5076 psi	37 000 kPa	5366 psi
Travel Circuits	35 000 kPa	5080 psi	35 000 kPa	5076 psi	35 000 kPa	5076 psi
Swing Circuits	27 500 kPa	3990 psi	29 400 kPa	4264 psi	35 000 kPa	5076 psi
Pilot Circuits	4120 kPa	598 psi	4120 kPa	600 psi	4.0-4.4 MPa	580-638 psi
Maximum Drawbar Pull	335 kN	75,300 lbf	492.5 kN	110,718 lbf	492 kN	110,718 lbf
	Two Speed Travel		Two Speed Travel		Two Speed Travel	
Maximum Travel Speed at Rated RPM	Lo: 2.9 km/h	1.8 mph	Lo: 2.8 km/h	1.7 mph	Lo: 4.1 km/h	2.6 mph
	Hi: 4.7 km/h	2.9 mph	Hi: 4.1 km/h	2.6 mph	Hi: 4.1 km/h	2.6 mph
Width of Standard Track Shoe	600 mm	24"	650 mm	2'1"	650 mm	2'1"
Overall Track Length	5370 mm	17'7"	5870 mm	19'3"	5870 mm	19'3"
Ground Contact Area with Std. Shoe	5.26 m ²	8150 in²	6.65 m ²	10,300 in²	6.65 m ²	10,300 in²
Track Gauge (shipping)	2740 mm	9'0"	2750 mm	9'0"	2750 mm	9'0"
Extended (working position)	—	—	3400 mm	11'2"	3400 mm	11'2"
Fuel Tank Refill Capacity	720 L	190 U.S. gal	935 L	247 U.S. gal	935 L	247 U.S. gal
Hydraulic System (includes tank)	570 L	151 U.S. gal	705 L	186 U.S. gal	729 L	193 U.S. gal
Hydraulic Tank	—	—	360 L	95 U.S. gal	—	—

*Operating weight includes coolant, lubricants, full fuel tank, boom, stick, bucket, operator 75 kg (165 lb) and standard shoes.

NOTE: Certain models may not be available in all Sales areas.

Specifications also vary by Sales area.

Contact your Cat dealer for details.

MODEL	390D		390D L		390F L	
Region Offerings	Asia Pacific, Japan		Europe, Middle East, Africa, CIS, Asia Pacific, North America, South America		World Wide	
Engine Power:						
ISO 9249	390 kW	523 hp	390 kW	523 hp	391 kW	524 hp
SAE J1349	390 kW	523 hp	390 kW	523 hp	391 kW	524 hp
Operating Weight*	92 763- 101 338 kg	204,507- 223,412 lb	88 080- 92 380 kg	194,216- 203,698 lb	86 033- 92 022 kg	189,670- 202,874 lb
Bucket Capacity Range (heaped)	—		—		—	
Engine Model	C18 ACERT		C18 ACERT		C18 ACERT	
Emission Standards	Tier 2/Japan 2001 (Tier 2) Equivalent OR Tier 3/Japan 2006 (Tier 3) Equivalent		Tier 2/Stage II Equivalent OR Tier 3/Stage IIIA Equivalent		Tier 4 Final/Stage IV/ Japan 2014 (Tier 4 Final) OR Tier 3/Stage IIIA/ Japan 2006 (Tier 3) Equivalent OR Tier 2/Stage II/ Japan 2001 (Tier 2) Equivalent	
Rated Engine RPM	1800		1800		1700 (Operation) 1900 (Travel)	
No. of Cylinders	6		6		6	
Displacement	18.1 L	1106 in³	18.1 L	1104.5 in³	18.1 L	1104.5 in³
Max. Implement Hydraulic Pump Output at Rated RPM	2 x 490 L/min	2 x 130 gpm	2 x 490 L/min	2 x 130 gpm	—	
Implement Travel	—	—	—	—	2 x 476 L/min	2 x 133 gpm
Relief Valve Settings:					2 x 532 L/min	2 x 141 gpm
Implement Circuits	35 000 kPa	5080 psi	35 000 kPa	5076.3 psi	35 000 kPa	5076 psi
Travel Circuits	35 000 kPa	5080 psi	35 000 kPa	5076.3 psi	35 000 kPa	5076 psi
Swing Circuits	26 000 kPa	3770 psi	26 000 kPa	3770.9 psi	35 000 kPa	5076 psi
Pilot Circuits	4120 kPa	600 psi	4120 kPa	597.56 psi	4.0-4.4 MPa	580-638 psi
Maximum Drawbar Pull	590 kN	133,090 lbf	590 kN	132,637 lbf	590 kN	132,637 lbf
	Two Speed Travel		Two Speed Travel		Two Speed Travel	
Maximum Travel Speed at Rated RPM	Lo: 2.8 km/h	1.7 mph	Lo: 2.8 km/h	1.7 mph	Lo: 4.5 km/h	2.8 mph
	Hi: 4.5 km/h	2.8 mph	Hi: 4.5 km/h	2.8 mph	Hi: 4.5 km/h	2.8 mph
Width of Standard Track Shoe	650 mm	2'1"	650 mm	2'1"	650 mm	2'1"
Overall Track Length	5840 mm	19'2"	6360 mm	20.8'6"	6358 mm	20'10"
Ground Contact Area with Std. Shoe	6.54 m ²	10,137 in²	7.22 m ²	11,191 in²	7.22 m ²	11,191 in²
Track Gauge (shipping)	2750 mm	9'0"	2750 mm	9.02'	2750 mm	9'0"
Extended (working position)	3510 mm	11'6"	3510 mm	11.51'	3510 mm	11.52'
Fuel Tank Refill Capacity	1240 L	328 U.S. gal	1240 L	327.57 U.S. gal	1240 L	328 U.S. gal
Hydraulic System (includes tank)	995 L	263 U.S. gal	995 L	262.85 U.S. gal	997 L	263 U.S. gal
Hydraulic Tank	810 L	214 U.S. gal	810 L	214 U.S. gal	—	

*Operating weight includes coolant, lubricants, full fuel tank, boom, stick, bucket, operator 75 kg (165 lb) and standard shoes.

NOTE: Certain models may not be available in all Sales areas.

Specifications also vary by Sales area.

Contact your Cat dealer for details.

SHIPPING DIMENSIONS KEYS

300.9 through 390F L

- A Cab height
 - B House width, without mirrors
 - C Track width, standard shoe
 - D Ground clearance, frame
 - E Ground clearance, counterweight
 - F Tail swing radius
 - G Overall track length
(grouser bar to grouser bar)
 - H Overall transport length
 - J Shipping height
 - K Length of track on ground
 - L Track gauge
-

M313D through M322F

- A Cab height
 - B Transport width
 - C Overall tire width
 - D Ground clearance, frame
 - E Transport length without boom
 - F Overall transport length
 - G Transport height
 - H Ground clearance, counterweight
 - J Tail swing radius
 - K Wheelbase length
 - L Overall width
(outrigger to outrigger)
-

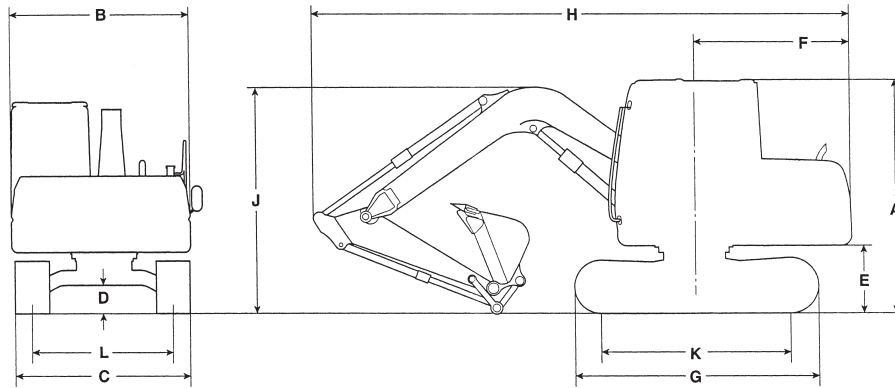

Region Offerings	300.9D		301.4C		301.7D		301.7D CR		302.2D	
	North America, South America, Canada, Australia, New Zealand, Europe, Africa, Middle East		North America, Canada, Australia, New Zealand, Europe, Africa, Middle East		North America, South America, Canada, Australia, New Zealand, Europe, Africa, Middle East		North America, Canada, Australia, New Zealand, Europe, Africa, Middle East		Europe, Africa, Middle East	
	mm	ft	mm	ft	mm	ft	mm	ft	mm	ft
A	2276	7'6"	2276	7'6"	2290	7'5"	2362	7'9"	2295	7'6"
B	730	2'5"	990	3'2"	990	3'3"	990	3'3"	990	3'3"
C	730	2'5"	990	3'2"	990	3'3"	990-1300	3'3"-4'3"	990-1300	3'3"-4'3"
D	—	—	—	—	—	—	—	—	—	—
E	—	—	—	—	—	—	—	—	—	—
F	747	2'5"	1075	3'5"	1169	3'10"	660	2'2"	1169	3'10"
G	1220	4'0"	1460	4'8"	1605	5'3"	1607	5'3"	1710	5'7"
H*	2746	9'0"	—	—	3810	12'8"	3584	11'9"	4027	13'3"
J*	—	—	—	—	2290	7'5"	2362	7'9"	2295	7'6"
K	—	—	—	—	—	—	—	—	—	—
L	—	—	—	—	760	2'6"	760-1070	2'6"-3'6"	740-1050	2'5"-3'2"

*Varies with stick length.

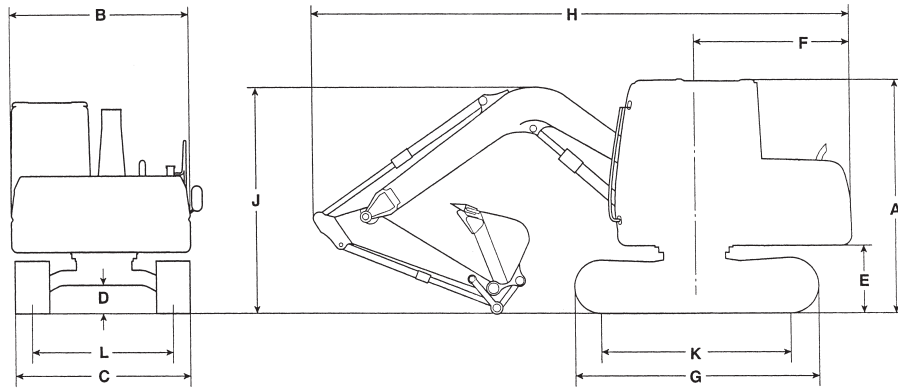

	302.4D		302.7D CR		303E CR		303.5E CR		303.5E2 CR	
Region Offerings	North America, South America, Canada, Australia, New Zealand, Europe, Africa, Middle East		North America, South America, Canada, Australia, New Zealand, Europe, Africa, Middle East		North America, South America, Canada, Australia, New Zealand		North America, South America, Canada, Australia, New Zealand, Europe, Africa, Middle East		North America, South America, Canada, Australia, New Zealand, Europe, Africa, Middle East	
	mm	ft	mm	ft	mm	ft	mm	ft	mm	ft
A	2390	7'10"	2408	7'9"	2500	8'2"	2500	8'2"	2500	8'2"
B	990	3'3"	1570	5'2"	1510	4'11"	1780	5'10"	1780	5'10"
C	1400	4'7"	1570	5'2"	1550	4'2"	1780	5'10"	1780	5'10"
D	—	—	—	—	317	1'0"	315	1'1"	315	1'1"
E	—	—	—	—	575	1'10"	565	1'10"	565	1'10"
F	1169	3'10"	760	2'5"	890	2'11"	890	2'11"	890	2'11"
G	1840	6'0"	2006	6'6"	2080	6'9"	2220	7'3"	2220	7'3"
H*	4027	13'3"	4255	13'9"	4470	14'7"	4730	15'6"	4730	15'6"
J*	2390	7'10"	—	—	2500	8'2"	1420	4'8"	1420	4'8"
K	—	—	—	—	1640	5'4"	1760	5'10"	1760	5'10"
L	1150	3'6"	—	—	1250	4'1"	1480	4'10"	1480	4'10"

*Varies with stick length.

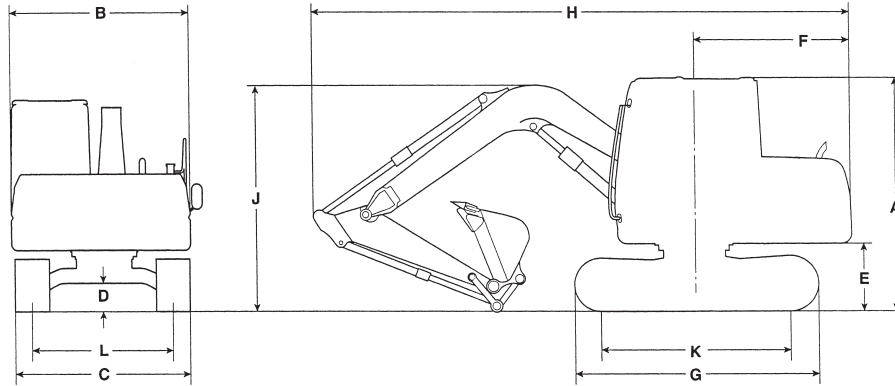

	304E2 CR		305E2 CR		305.5E2 CR		307E2		308E2 CR SB	
Region Offerings	North America, South America, Canada, Australia, New Zealand, Europe, Africa, Middle East		North America, South America, Canada, Australia, New Zealand, Europe, Africa, Middle East		North America, South America, Canada, Australia, New Zealand, Europe, Africa, Middle East		North America, Canada, Europe		North America, Canada, Australia, New Zealand, Europe	
	mm	ft	mm	ft	mm	ft	mm	ft	mm	ft
A	2500	8'2"	2550	8'4"	2550	8'4"	2540	8'4"	2550	8'4"
B	1950	6'5"	1980	6'6"	1980	6'6"	2290	7'6"	2280	7'7"
C	1950	6'5"	1980	6'6"	1980	6'6"	2200	7'3"	2320	7'7"
D	310	1'0"	340	1'1"	340	1'1"	370	1'3"	384	1'3"
E	565	1'10"	615	2'0"	615	2'0"	775	2'7"	760	2'5"
F	975	3'2"	1100	3'7"	1130	3'8"	1750	5'9"	1570	5'2"
G	2220	7'3"	2580	8'5"	2580	8'6"	2760	9'1"	2903	9'6"
H*	4820	15'10"	5180	17'0"	5330	17'6"	6080	19'11"	6488	21'3"
J*	1480	4'10"	2540	8'4"	2540	8'4"	2630	8'8"	2550	8'4"
K	1760	5'10"	2065	6'11"	2065	6'11"	2125	7'0"	2280	7'6"
L	1580	5'2"	1580	5'2"	1580	5'2"	1750	5'9"	1870	6'2"

*Varies with stick length.

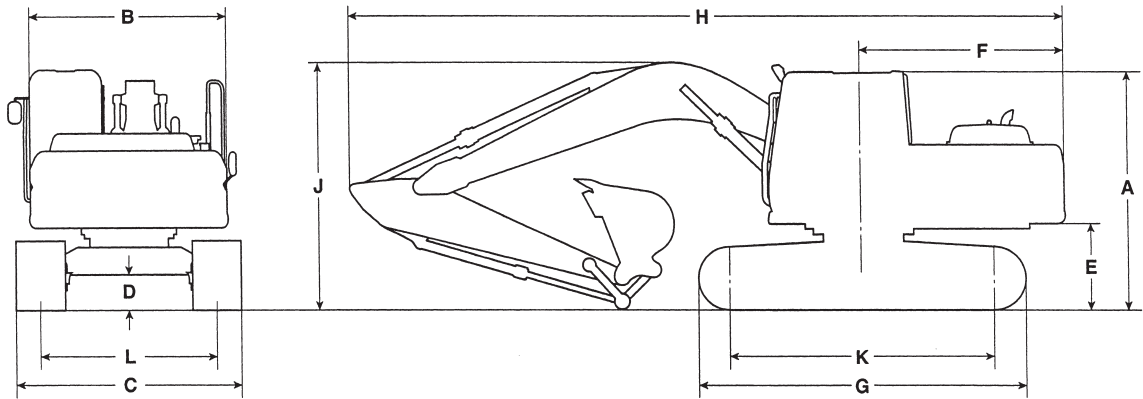

Region Offerings	311F L RR		312D2		312D2 GC		312D2 L	
	North America, Europe, Australia, New Zealand and Polynesia, Japan		Asia Pacific		China		Middle East, Africa, CIS, Asia Pacific, South America	
	mm	ft	mm	ft	mm	ft	mm	ft
A	2760	9'1"	2760	9'1"	2760	9'1"	2760	9'1"
B	2490	8'2"	2490	8'2"	2490	8'2"	2490	8'2"
C	2490	8'2"	2490	8'2"	2490	8'2"	2490	8'2"
D	440	17"	440	17"	440	17"	440	17"
E	910	3'0"	900	3'0"	900	3'0"	900	3'0"
F	1750	5'9"	2140	7'0"	2140	7'0"	2140	7'0"
G	3490	11'5"	3490	11'5"	3490	11'5"	3750	12'4"
H*	6910	22'8"	7610	25'0"	7610	25'0"	7610	25'0"
J*	2820	9'3"	2830	9'3"	2830	9'3"	2830	9'3"
K	2780	9'1"	2780	9'1"	2780	9'1"	3040	10'0"
L	1990	6'6"	1990	6'6"	1990	6'6"	1990	6'6"

*Varies with stick length.

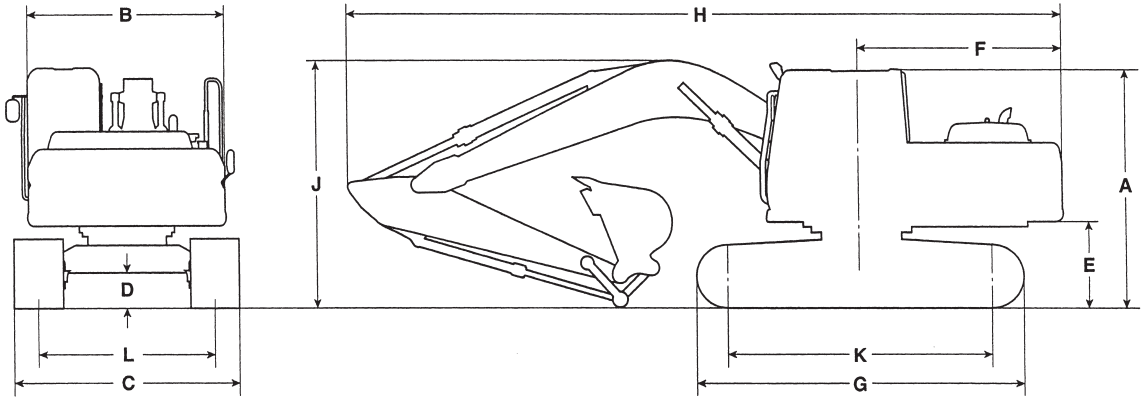

7

Region Offerings	312E		312E L		312E VA		312F GC		313D2	
	Europe, Australia, New Zealand and Polynesia, Japan		North America, Europe, Australia, New Zealand and Polynesia		Europe		Japan		China, Asia Pacific	
	mm	ft	mm	ft	mm	ft	mm	ft	mm	ft
A	2770	9'1"	2770	9'1"	2770	9'1"	2760	9'1"	2670	8'9"
B	2500	8'3"	2500	8'3"	2500	8'3"	2490	8'2"	2490	8'2"
C	2590	8'6"	2590	8'6"	2590	8'6"	2490	8'2"	2490	8'2"
D	440	17"	440	17"	440	17"	440	1'5"	440	17"
E	890	2'11"	890	2'11"	890	2'11"	900	2'11"	900	3'0"
F	2160	7'11"	2160	7'11"	2160	7'11"	2180	7'1"	2140	7'0"
G	3490	11'5"	3750	12'4"	3750	12'4"	3490	11'5"	3490	11'5"
H*	7680	25'2"	7670	25'2"	7730	25'4"	7680	25'2"	7610	25'0"
J*	2980	9'9"	2980	9'9"	2980	9'9"	2830	9'3"	2830	9'3"
K	2780	9'1"	3040	10'0"	3040	10'0"	2780	9'1"	2780	9'1"
L	1990	6'6"	1990	6'6"	1990	6'6"	1990	6'6"	1990	6'6"

*Varies with stick length.

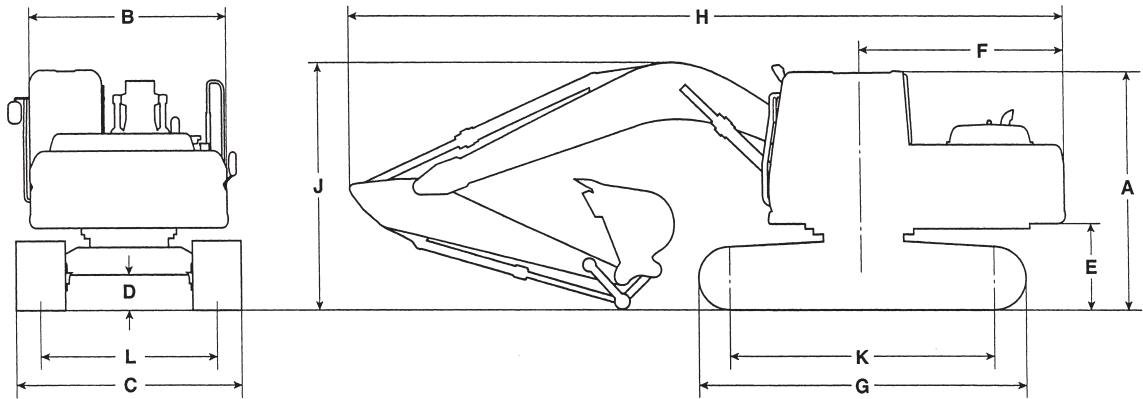

Region Offerings	313D2 LGP		313F L GC		314E CR		314E LCR		314E LCR VAB	
	Asia Pacific		North America, Europe, Turkey		Australia, New Zealand and Polynesia, Japan		North America, Europe, Australia, New Zealand and Polynesia, Japan		Europe	
	mm	ft	mm	ft	mm	ft	mm	ft	mm	ft
A	3150	10'4"	2760	9'1"	2810	9'3"	2810	9'3"	2810	9'3"
B	2490	8'2"	2490	8'2"	2490	8'2"	2490	8'2"	2490	8'2"
C	3040	10'0"	2490	8'2"	2490	8'2"	2490	8'2"	2490	8'2"
D	650	2'2"	440	1'5"	440	1'7"	440	1'7"	440	1'7"
E	1250	4'1"	900	2'11"	860	2'10"	860	2'10"	860	2'10"
F	2090	6'10"	2180	7'1"	1490	4'11"	1490	4'11"	1490	4'11"
G	4020	13'2"	3740	12'3"	3490	11'5"	3750	12'4"	3750	12'4"
H*	7600	24'11"	7700	25'3"	7610	25'0"	7610	25'0"	7580	24'10"
J*	3220	10'7"	2830	9'3"	3000	9'10"	3000	9'10"	3000	9'10"
K	3130	10'3"	3040	10'0"	2780	9'1"	3040	11'5"	3040	11'5"
L	2080	6'10"	1990	6'6"	1990	6'6"	1990	6'6"	1990	6'6"

*Varies with stick length.

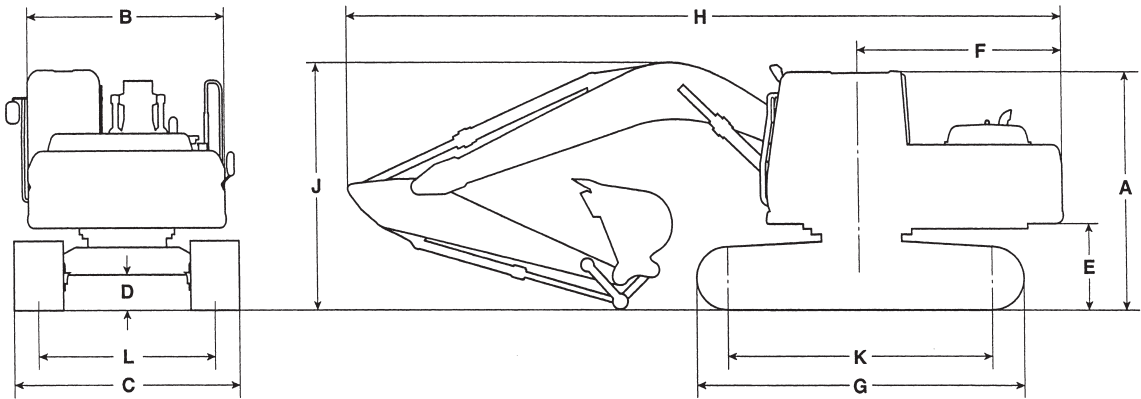

7

Region Offerings	316E L		316E L VA		318D2 L		318E L		318E L VA	
	North America, Europe, Australia, New Zealand and Polynesia, Japan		Europe		Middle East, Africa, CIS, South America, Asia Pacific, China		North America, Europe, Australia, New Zealand and Polynesia		Europe	
	mm	ft	mm	ft	mm	ft	mm	ft	mm	ft
A	2890	9'6"	2890	9'6"	2870	9'5"	2890	9'6"	2890	9'6"
B	2520	8'3"	2520	8'3"	2490	8'2"	2520	8'3"	2520	8'3"
C	2590	8'6"	2590	8'6"	2590	8'6"	2590	8'6"	2590	8'6"
D	440	1'5"	440	1'5"	460	1'6"	440	1'5"	440	1'5"
E	1010	3'4"	1010	3'4"	1000	3'3"	1010	3'4"	1010	3'4"
F	2500	8'2"	2500	8'2"	2500	8'2"	2500	8'2"	2500	8'2"
G	3970	13'0"	3970	13'0"	3970	13'0"	4075	13'4"	4075	13'4"
H*	8570	28'1"	8630	28'4"	8540	28'0"	8580	28'2"	8630	28'4"
J*	2980	9'9"	2980	9'9"	3030	9'11"	2980	9'9"	2980	9'9"
K	3170	10'5"	3170	10'5"	3170	10'5"	3265	10'9"	3265	10'9"
L	1990	6'6"	1990	6'6"	1990	6'6"	1990	6'6"	1990	6'6"

*Varies with stick length.

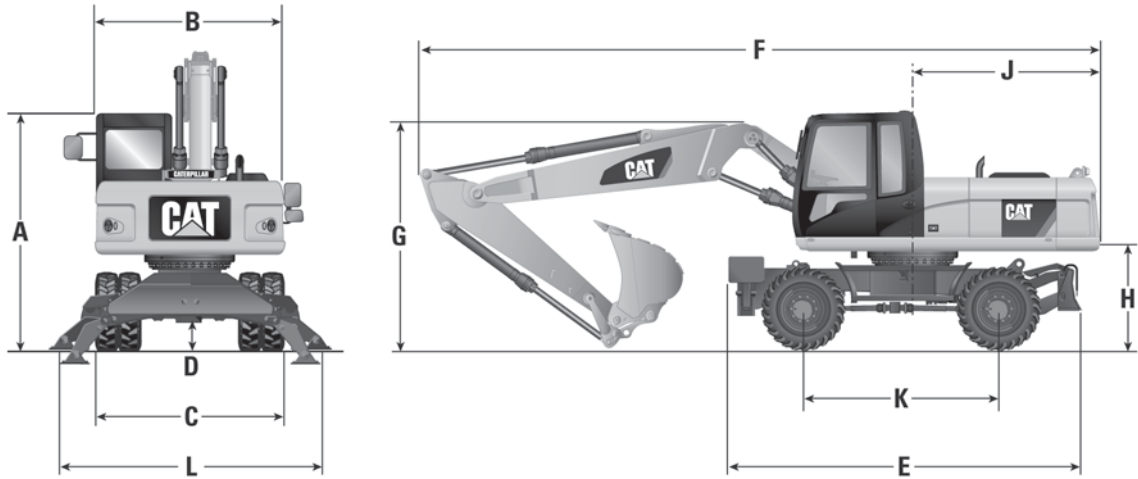

	M313D		M315D		M315D2		M316D	
	mm	ft	mm	ft	mm	ft	mm	ft
A	3120	10'3"	3150	10'4"	3120	10'3"	3170	10'5"
B	2540	8'4"	2540	8'4"	2540	8'4"	2540	8'4"
C*	2550	8'4"	2550	8'4"	2550	8'4"	2550	8'4"
Dozer width	2540	8'4"	2550	8'4"	2540	8'4"	2550	8'4"
D	370	1'3"	370	1'3"	370	1'3"	370	1'3"
E¹	4755	15'7"	4805	15'9"	4755	15'7"	4825	15'10"
E²	4965	16'3"	5015	16'5"	4965	16'3"	4860	15'11"
E³	4355	14'3"	4405	14'5"	4355	14'3"	4330	14'2"
F	8080	26'6"	8330	27'4"	8080	26'6"	8400	27'7"
G	3120	10'3"	3150	10'4"	3120	10'3"	3170	10'5"
H	1240	4'1"	1260	4'2"	1240	4'1"	1280	4'2"
J	2076	6'10"	2215	7'3"	2076	6'10"	2290	7'6"
K	2500	8'2"	2550	8'4"	2500	8'2"	2600	8'6"
L	3645	12'0"	3645	12'0"	3645	12'0"	3675	12'1"

E¹ 2 Sets Outriggers.

E² Outriggers/Dozer.

E³ Dozer only.

*With standard tires 10.00-20 dual pneumatic.

NOTE: Shipping dimensions above are for standard machine equipped with one-piece boom and medium stick.

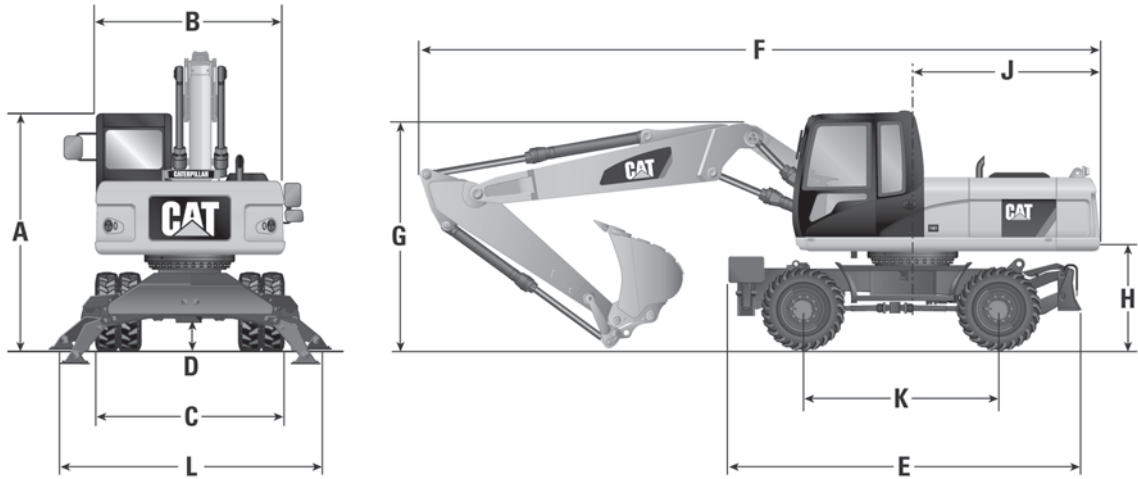

7

	M317D2		M318D		M320D2		M322D/D2	
	mm	ft	mm	ft	mm	ft	mm	ft
A	3150	10'4"	3170	10'5"	3170	10'5"	3200	10'6"
B	2540	8'4"	2540	8'4"	2540	8'4"	2670	8'9"
C*	2550	8'4"	2550	8'4"	2550	8'4"	2750	9'0"
Dozer width	2550	8'4"	2550	8'4"	2550	8'4"	2750	9'0"
D	370	1'3"	370	1'3"	370	1'3"	380	1'3"
E¹	4805	15'9"	4855	15'11"	4855	15'11"	5025	16'6"
E²	5015	16'5"	4925	16'2"	4925	16'2"	5060	16'7"
E³	4405	14'5"	4285	14'1"	4285	14'1"	4410	14'6"
F	8330	27'4"	8960	29'5"	8960	29'5"	9640	31'7"
G	3150	10'4"	3210	10'6"	3210	10'6"	3250	10'8"
H	1260	4'4"	1280	4'2"	1280	4'2"	1310	4'4"
J	2215	7'3"	2565	8'5"	2565	8'5"	2821	9'3"
K	2550	8'4"	2600	8'6"	2600	8'6"	2750	9'0"
L	3645	12'0"	3676	12'1"	3676	12'1"	3940	12'11"

E¹ 2 Sets Outriggers.
 E² Outriggers/Dozer.
 E³ Dozer only.

*With standard tires 10.00-20 dual pneumatic.

NOTE: Shipping dimensions above are for standard machine equipped with one-piece boom and medium stick.

Hydraulic Excavators

Shipping Dimensions

● M314F ● M316F ● M318F ● M320F ● M322F

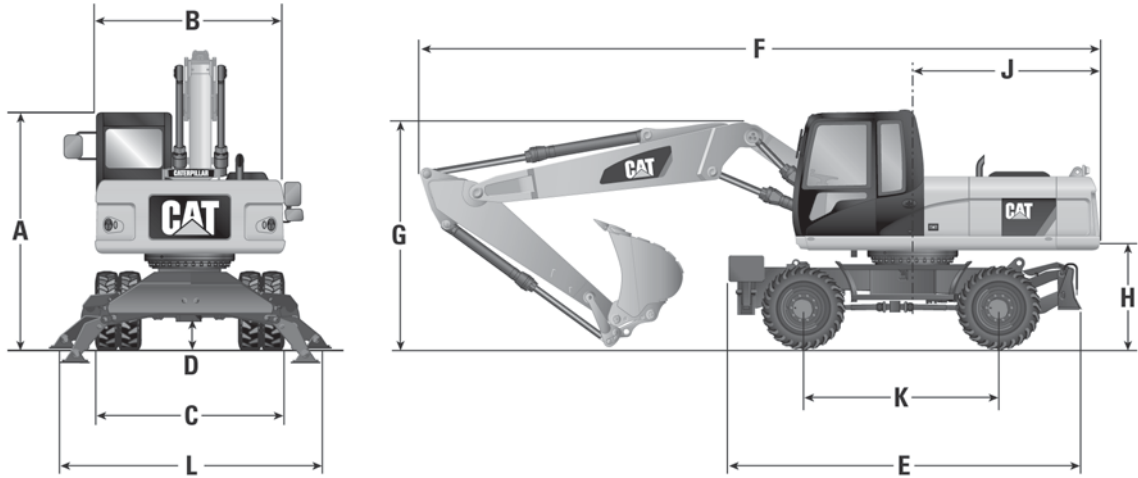

Linkage	M314F		M316F		M318F		M320F		M322F	
	mm	ft	mm	ft	mm	ft	mm	ft	mm	ft
Hydraulically Adjustable Boom, Medium Stick										
A	3150	10'4"	3170	10'5"	3190	10'6"	3190	10'6"	3220	10'7"
B	2540	8'4"	2540	8'4"	2540	8'4"	2540	8'4"	2670	8'9"
C*	2550	8'4"	2550	8'4"	2550	8'4"	2550	8'4"	2750	9'0"
Dozer width	2540	8'4"	2540	8'4"	2550	8'4"	2550	8'4"	2750	9'0"
D	370	1'3"	370	1'3"	370	1'3"	370	1'3"	380	1'3"
E¹	4710	15'5"	4805	15'9"	4855	15'11"	4855	15'11"	5040	16'6"
E²	4920	16'2"	4970	16'4"	4950	16'3"	4950	16'3"	5190	17'0"
E³	4310	14'2"	4360	14'4"	4380	14'4"	4380	14'4"	4500	14'9"
F	8455	27'9"	8640	28'4"	8610	28'3"	8850	29'0"	9555	31'4"
G	3150	10'4"	3170	10'5"	3190	10'6"	3190	10'6"	3220	10'7"
H	1240	4'1"	1260	4'2"	1280	4'2"	1280	4'2"	1310	4'4"
J	2090	6'10"	2220	7'3"	2300	7'7"	2570	8'5"	2825	9'3"
K	2500	8'2"	2550	8'4"	2600	8'6"	2600	8'6"	2750	9'0"
L	3645	11'11"	3645	11'11"	3680	12'1"	3680	12'1"	3930	12'11"

E¹ 2 Sets Outriggers.

E² Outriggers/Dozer.

E³ Dozer only.

*With standard tires 10.00-20 dual pneumatic.

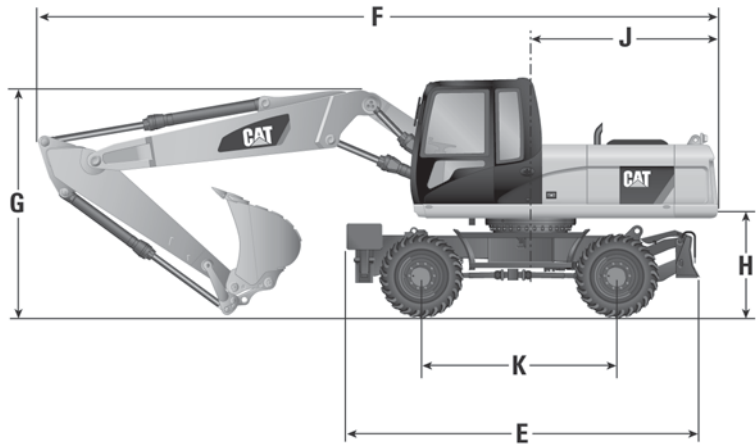
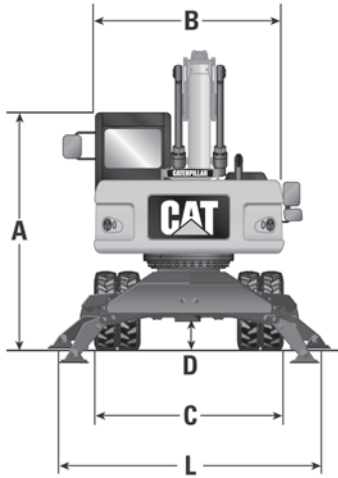

7

Linkage	M314F		M316F		M318F		M320F		M322F	
	mm	ft	mm	ft	mm	ft	mm	ft	mm	ft
One-piece Boom, Medium Stick										
A	3150	10'4"	3170	10'5"	3190	10'6"	3190	10'6"	3220	10'7"
B	2540	8'4"	2540	8'4"	2540	8'4"	2540	8'4"	2670	8'9"
C*	2550	8'4"	2550	8'4"	2550	8'4"	2550	8'4"	2750	9'0"
Dozer width	2540	8'4"	2540	8'4"	2550	8'4"	2550	8'4"	2750	9'0"
D	370	1'3"	370	1'3"	370	1'3"	370	1'3"	380	1'3"
E¹	4710	15'5"	4805	15'9"	4855	15'11"	4855	15'11"	5040	16'6"
E²	4920	16'2"	4970	16'4"	4950	16'3"	4950	16'3"	5190	17'0"
E³	4310	14'2"	4360	14'4"	4380	14'4"	4380	14'4"	4500	14'9"
F	8250	27'1"	8490	27'10"	8460	27'9"	8960	29'5"	9710	31'10"
G	3150	10'4"	3170	10'5"	3190	10'6"	3190	10'6"	3220	10'7"
H	1240	4'1"	1260	4'2"	1280	4'2"	1280	4'2"	1310	4'4"
J	2090	6'10"	2220	7'3"	2300	7'7"	2570	8'5"	2825	9'3"
K	2500	8'2"	2550	8'4"	2600	8'6"	2600	8'6"	2750	9'0"
L	3645	11'11"	3645	11'11"	3680	12'1"	3680	12'1"	3930	12'11"

E¹ 2 Sets Outriggers.

E² Outriggers/Dozer.

E³ Dozer only.

*With standard tires 10.00-20 dual pneumatic.

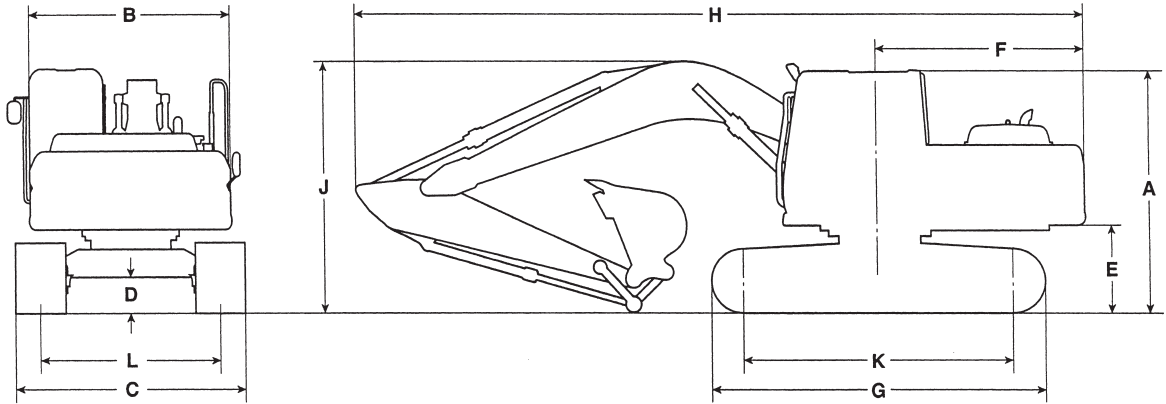

Region Offerings	320D2 Reach		320D2 Mass		320D2 GC Reach		320D2 L Reach	
	Asia Pacific, China, Latin America		Asia Pacific, China, Latin America		South America, Middle East, Africa, CIS, Asia Pacific, China		Africa, Middle East, Asia Pacific, China, Latin America	
	mm	ft	mm	ft	mm	ft	mm	ft
A	2950	9'8"	2950	9'8"	2950	9'8"	2950	9'8"
B	2740	9'0"	2740	9'0"	2740	9'0"	2740	9'0"
C	2990	9'10"	2990	9'10"	2800	9'2"	3170	10'5"
D	450	1'6"	450	1'6"	450	1'6"	450	1'6"
E	1020	3'4"	1020	3'4"	1020	3'4"	1020	3'4"
F	2750	9'0"	2750	9'0"	2750	9'0"	2750	9'0"
G	4080	13'5"	4080	13'5"	4080	13'5"	4460	14'8"
H*	9460	31'0"	3280	10'9"	9460	31'0"	9460	31'0"
J*	3030	9'11"	3280	10'9"	3030	9'11"	3030	9'11"
K	3270	10'9"	3270	10'9"	3270	10'9"	3650	12'0"
L	2200	7'3"	2200	7'3"	2200	7'3"	2380	7'10"

*Varies with stick length.

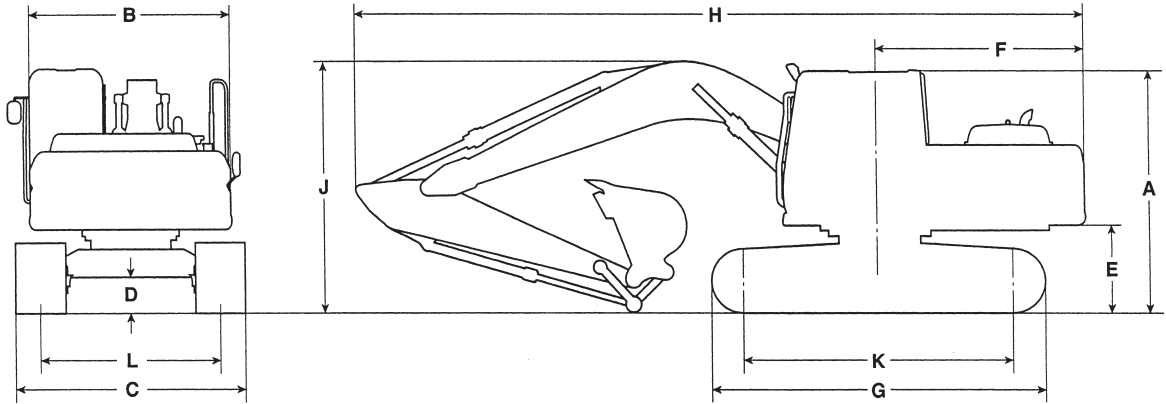

Region Offerings	320D2 L Mass		320E		320E L		320E L SLR		320E LRR	
	Africa, Middle East, Asia Pacific, China, Latin America		Japan		North America, Australia, New Zealand		North America		North America, Australia, New Zealand	
	mm	ft	mm	ft	mm	ft	mm	ft	mm	ft
A	2950	9'8"	3150	10'3"	3150	10'3"	3150	10'3"	3152	10'4"
B	2490	8'2"	2770	9'1"	2770	9'1"	2770	9'1"	2820	9'1"
C	3170	10'5"	2800	9'2"	3170	10'5"	3170	10'5"	3170	10'5"
D	450	1'6"	450	1'6"	450	1'6"	450	1'6"	450	1'6"
E	1020	3'4"	1020	3'4"	1020	3'4"	1020	3'4"	1000	3'3"
F	2750	9'0"	2830	9'3"	2830	9'3"	2830	9'3"	2080	6'8"
G	4460	14'8"	4080	13'4"	4460	14'6"	4460	14'6"	4455	14'7"
H	3280	10'9"	9530	31'3"	9340	30'8"	12 750	41'10"	8970	29'5"
J*	3280	10'9"	3020	9'9"	3740	12'3"	3180	10'4"	3150	10'4"
K	3650	12'0"	3270	10'7"	3650	12'0"	3650	12'0"	3650	12'0"
L	2380	7'10"	2200	7'2"	2380	7'10"	2380	7'10"	2380	7'10"

*Varies with stick length.

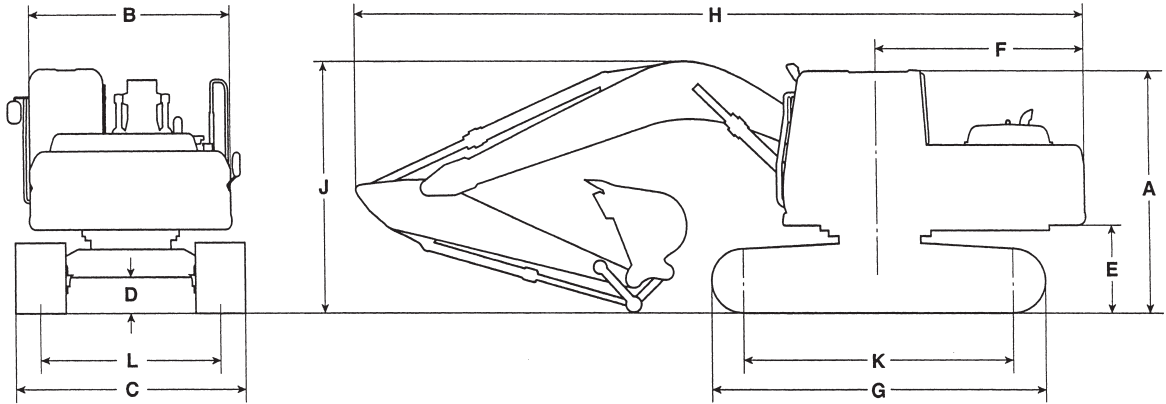

Region Offerings	320E		320E L		320E LN		320E L SLR		320E LRR		320F L	
	Europe		Europe		Europe		Europe		Europe		North America	
	mm	ft	mm	ft	mm	ft	mm	ft	mm	ft	mm	ft
A	3150	10'3"	3150	10'3"	3150	10'3"	3150	10'3"	3152	10'4"	3130	10'3"
B	2770	9'1"	2770	9'1"	2540	9'1"	2770	9'1"	2820	9'1"	2770	9'1"
C	2800	9'2"	3170	10'5"	3170	10'5"	3170	10'5"	3170	10'5"	3170	10'5"
D	450	1'6"	450	1'6"	450	1'6"	450	1'6"	450	1'6"	450	1'6"
E	1020	3'4"	1020	3'4"	1020	3'4"	1020	3'4"	1000	3'3"	1020	3'4"
F	2830	9'3"	2830	9'3"	2830	9'3"	2830	9'3"	2080	6'8"	2830	7'10"
G	4080	13'4"	4460	14'6"	4460	14'6"	4460	14'6"	4455	14'7"	4460	14'8"
H	9530	31'3"	9540	31'4"	9570	31'5"	12 750	46'2"	8970	29'5"	9540	31'4"
J*	3020	9'9"	3150	10'3"	3150	10'3"	3180	10'4"	3150	10'4"	3130	10'3"
K	3270	10'7"	3650	12'0"	3650	12'0"	3650	12'0"	3650	12'0"	3650	12'0"
L	2200	7'2"	2380	7'10"	2000	6'7"	2380	7'10"	2380	7'10"	2380	7'10"

*Varies with stick length.

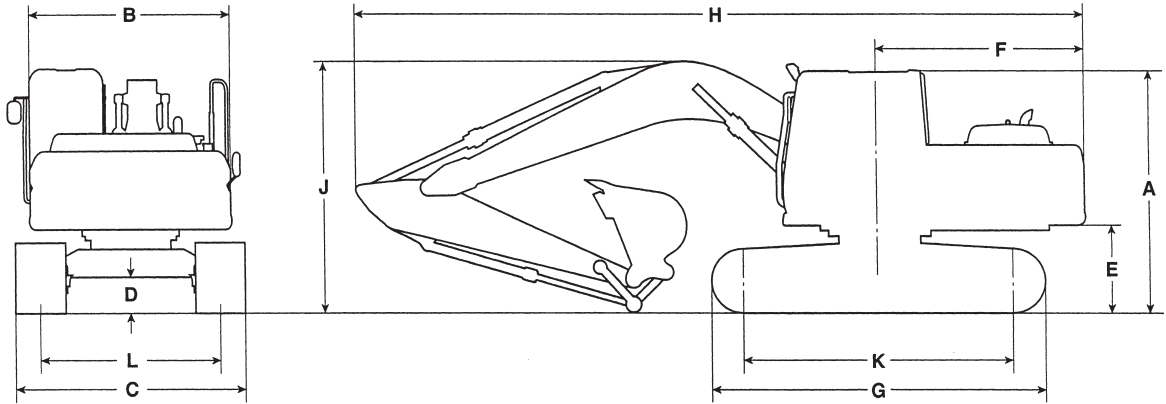

7

Region Offerings	323D2 L		323E L		323E LVA		323E L SLR		323E LN	
	South America, Middle East, Africa, CIS, China		Europe		Europe		Europe		Europe	
	mm	ft	mm	ft	mm	ft	mm	ft	mm	ft
A	2950	9'8"	3150	10'4"	3150	10'4"	3150	10'4"	3150	10'4"
B	2490	8'2"	2770	9'1"	2770	9'1"	2770	9'1"	2540	8'4"
C	3170	10'5"	3170	10'5"	3170	10'5"	3170	10'5"	2540	8'4"
D	450	1'6"	450	1'6"	450	1'6"	450	1'6"	450	1'6"
E	1020	3'4"	1020	3'4"	1020	3'4"	1020	3'4"	1020	3'4"
F	2750	9'0"	2830	9'3"	2830	9'3"	2830	9'3"	2830	9'3"
G	4455	14'7"	4460	14'6"	4460	14'6"	4460	14'6"	4460	14'6"
H	9460	31'0"	9540	31'4"	9780	32'1"	14 070	46'2"	9560	31'5"
J*	3030	9'11"	3150	10'4"	3150	10'4"	3180	10'4"	3150	10'4"
K	3650	12'0"	3650	12'0"	3650	12'0"	3650	12'0"	3650	12'0"
L	2380	7'10"	2380	7'10"	2380	7'10"	2380	7'10"	2000	6'7"

*Varies with stick length.

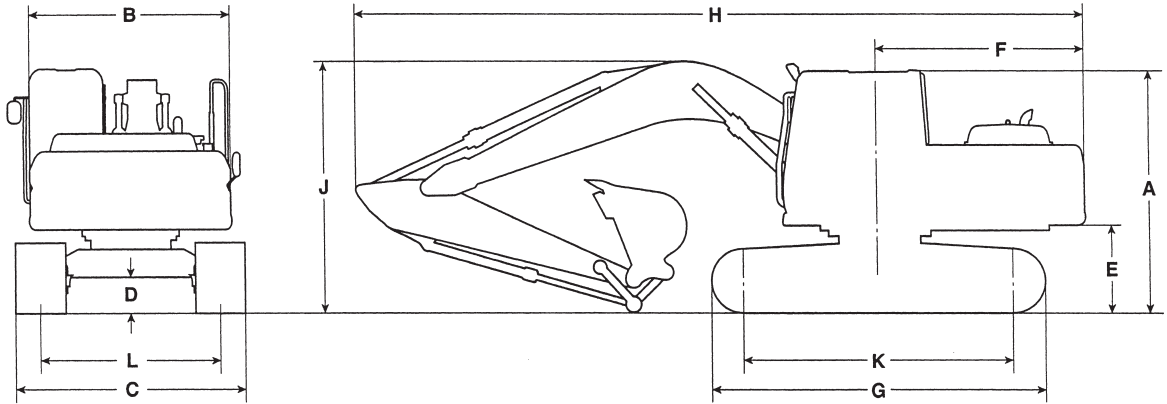

Region Offerings	323E SA		323E SA VA		323F L Reach		323F L Reach	
	Europe		Europe		North America		Europe	
	mm	ft	mm	ft	mm	ft	mm	ft
A	3230	10'7"	3230	10'7"	3010	9'11"	3150	10'3"
B	2540	8'4"	2540	8'4"	2770	9'1"	2770	9'1"
C	2540	8'4"	2540	8'4"	3170	10'5"	2980	9'9"
D	480	1'7"	480	1'7"	450	1'6"	450	1'6"
E	1090	3'7"	1090	3'7"	1020	3'4"	1020	3'4"
F	2830	9'3"	2830	9'3"	2830	9'3"	2830	9'3"
G	4360	14'4"	4360	14'4"	4460	14'6"	4460	14'6"
H*	9570	31'5"	9820	32'3"	9540	31'4"	9540	31'4"
J*	3230	10'7"	3230	10'7"	3130	10'3"	3130	10'3"
K	3490	11'5"	3490	11'5"	3650	12'0"	3650	12'0"
L	1900	6'3"	1900	6'3"	2380	7'10"	2380	7'10"

*Varies with stick length.

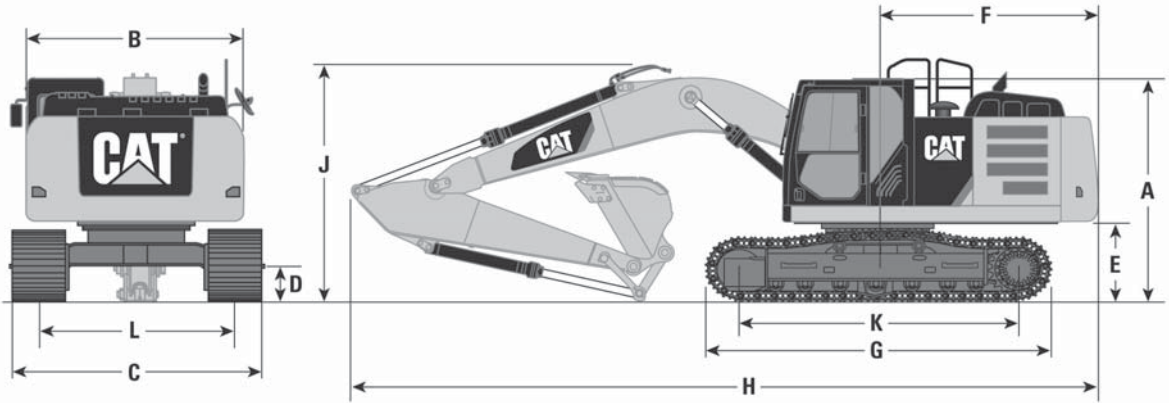

Region Offerings	324E Reach**		324E Mass***		324E L Reach**		324E L Mass***		324E L Reach****		324E L Mass*****	
	Japan		Japan		North America		North America		Europe		Europe	
	mm	ft	mm	ft	mm	ft	mm	ft	mm	ft	mm	ft
A	2996	9'10"	2996	9'10"	2996	9'10"	2996	9'10"	2996	9'10"	2996	9'10"
B	2934	9'8"	2934	9'8"	2934	9'8"	2934	9'8"	2934	9'8"	2934	9'8"
C	3180	10'5"	3180	10'5"	3380	11'1"	3380	11'1"	3190	10'6"	3190	10'6"
D	475	1'6"	475	1'6"	440	1'5"	440	1'5"	440	1'5"	440	1'5"
E	1088	3'7"	1088	3'7"	1088	3'7"	1088	3'7"	1088	3'7"	1088	3'7"
F	2947	9'8"	2947	9'8"	2947	9'8"	2947	9'8"	2947	9'8"	2947	9'8"
G	4261	13'11"	4261	13'11"	4640	15'3"	4640	15'3"	4640	15'3"	4640	15'3"
H*	10 063	33'0"	9480	31'1"	10 063	33'0"	9480	31'1"	10 100	33'2"	9480	31'1"
J*	3221	10'7"	3500	11'6"	3221	10'7"	3500	11'6"	3410	11'2"	3500	11'6"
K	3450	11'4"	3450	11'4"	3830	12'7"	3830	12'7"	3830	12'7"	3830	12'7"
L	2390	7'10"	2390	7'10"	2590	8'6"	2590	8'6"	2590	8'6"	2590	8'6"

*Varies with stick length.

**R2.95 (9'8") stick and 790 mm (31") shoes.

***M2.5 (8'2") stick and 790 mm (31") shoes.

****R2.5 (8'2") stick and 600 mm (24") shoes.

*****M2.5 (8'2") stick and 600 mm (24") shoes.

Hydraulic Excavators

Shipping Dimensions

- 324E L
- 324E LN
- 324E L SLR

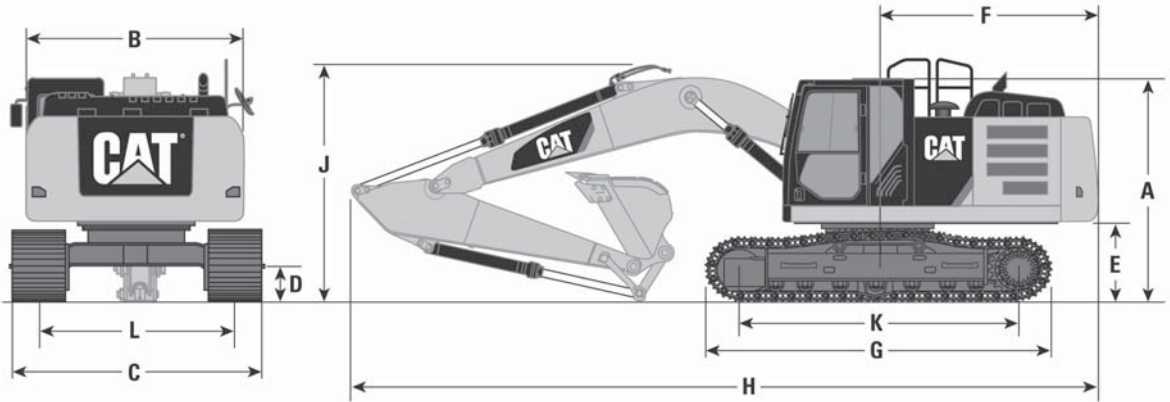

	324E L VA		324E LN Reach**		324E LN Mass***		324E LN VA		324E L SLR	
Region Offerings	Europe		Europe		Europe		Europe		Europe	
	mm	ft	mm	ft	mm	ft	mm	ft	mm	ft
A	2996	9'10"	2996	9'10"	2996	9'10"	2996	9'10"	2996	9'10"
B	2934	9'8"	2934	9'8"	2934	9'8"	2934	9'8"	2934	9'8"
C	3190	10'6"	2990	9'10"	2990	9'10"	2990	9'10"	3190	10'6"
D	440	1'5"	440	1'5"	440	1'5"	440	1'5"	440	1'5"
E	1088	3'7"	1088	3'7"	1088	3'7"	1088	3'7"	1088	3'7"
F	2947	9'8"	2947	9'8"	2947	9'8"	2947	9'8"	2947	9'8"
G	4640	15'3"	4640	15'3"	4640	15'3"	4640	15'3"	4640	15'3"
H*	10 199	33'6"	10 100	33'2"	9480	31'1"	10 199	33'6"	14 352	47'1"
J*	3115	10'3"	3410	11'2"	3500	11'6"	3115	10'3"	3155	10'4"
K	3830	12'7"	3830	12'7"	3830	12'7"	3830	12'7"	3830	12'7"
L	2590	8'6"	2390	7'10"	2390	7'10"	2390	7'10"	2590	8'6"

*Varies with stick length.

**R2.5 (8'2") stick and 600 mm (24") shoes.

***M2.5 (8'2") stick and 600 mm (24") shoes.

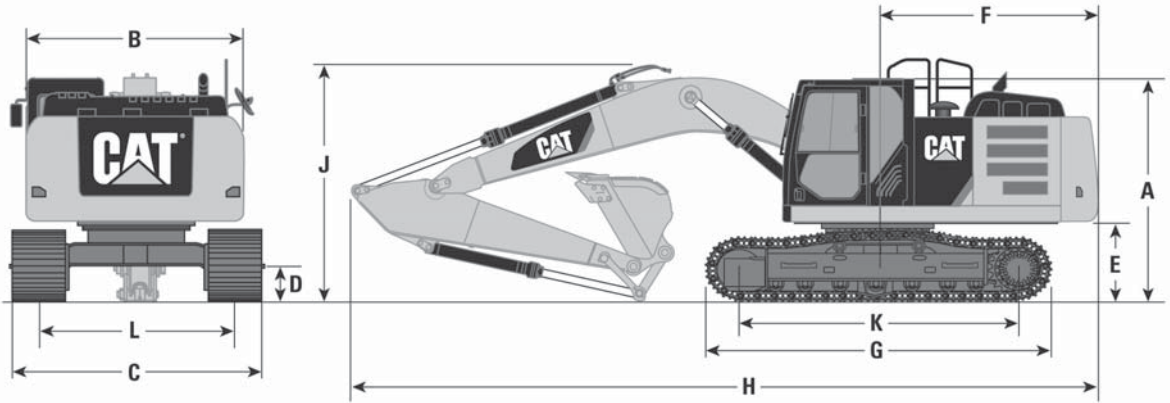

325F L Reach

325F L VA

Region Offerings	North America, Europe, Australia, New Zealand		Europe	
	mm	ft	mm	ft
A	3060	10'0"	3060	10'0"
B	2980	9'9"	2980	9'9"
C	3170	10'5"	3170	10'5"
D	450	1'6"	450	1'6"
E	960	3'2"	960	3'2"
F	1720	5'8"	1720	5'8"
G	4460	14'8"	4460	14'8"
H*	8920	29'3"	9180	30'1"
J*	3180	10'5"	3140	10'4"
K	3650	12'0"	3650	12'0"
L	2380	7'10"	2380	7'10"

*Varies with stick length.

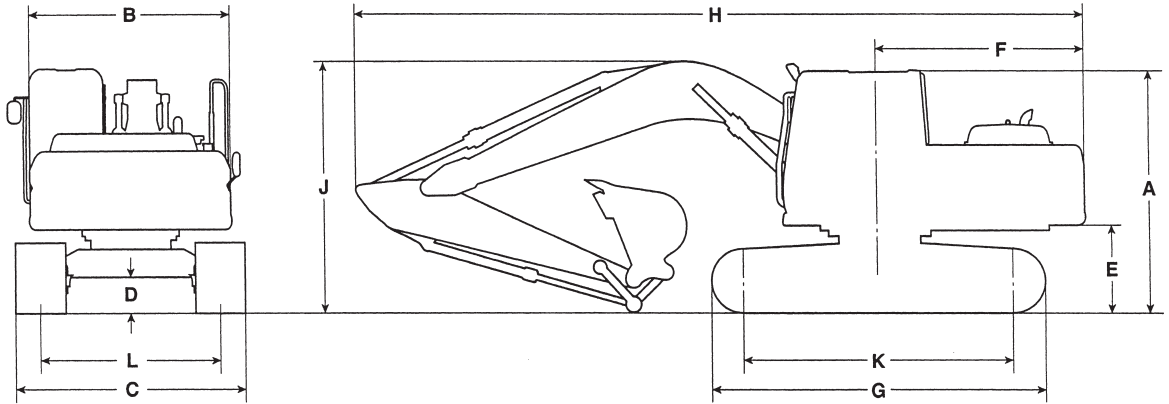

326D2 L Reach

Region Offerings	South America, Middle East, Africa, CIS, Asia Pacific, China	
	mm	ft
A	2980	9'9"
B	2900	9'6"
C	3380	11'1"
D	440	1'5"
E	1060	3'6"
F	3000	9'10"
G	4630	15'2"
H*	10 050	33'0"
J*	3170	10'5"
K	3830	12'7"
L	2590	8'6"

*Varies with stick length.

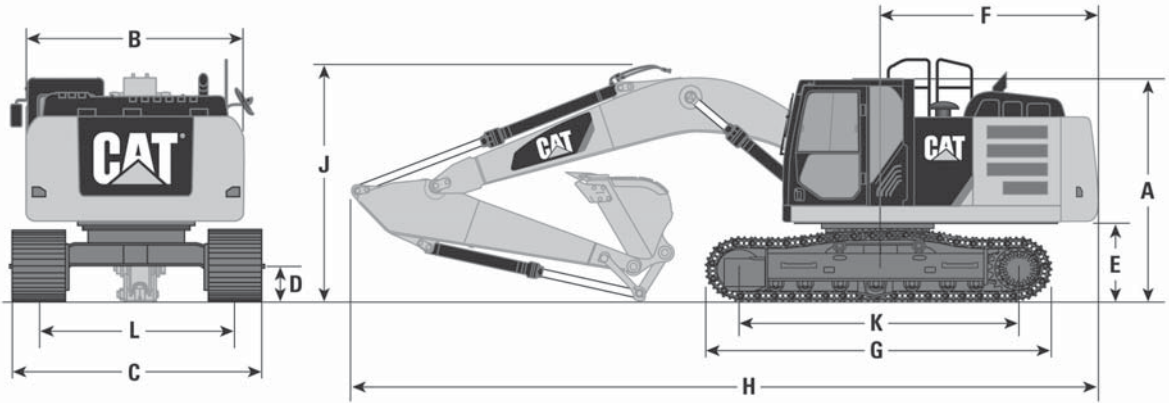

7

Region Offerings	326F Reach		326F L Reach		326F L VA		326F L SLR		326F LN Reach	
	Japan		Japan, North America, Europe		Europe		Japan, North America, Europe		Europe	
	mm	ft	mm	ft	mm	ft	mm	ft	mm	ft
A	2996	9'10"	2996	9'10"	2996	9'10"	2996	9'10"	2996	9'10"
B	2934	9'8"	2934	9'8"	2934	9'8"	2934	9'8"	2934	9'8"
C	2990	9'10"	3380	11'1"	3380	11'1"	3380	11'1"	2990	9'10"
D	440	1'5"	440	1'5"	440	1'5"	440	1'5"	440	1'5"
E	1088	3'7"	1088	3'7"	1088	3'7"	1088	3'7"	1088	3'7"
F	2947	9'8"	2947	9'8"	2947	9'8"	2947	9'8"	2947	9'8"
G	4250	13'11"	4640	15'3"	4640	15'3"	4640	15'3"	4640	15'3"
H*	10 063	33'0"	10 063	33'0"	10 200	33'6"	14 350	47'1"	10 063	33'0"
J*	3221	10'7"	3221	10'7"	3120	10'3"	3230	10'7"	3221	10'7"
K	3450	11'4"	3830	12'7"	3830	12'7"	3830	12'7"	3830	12'7"
L	2390	7'10"	2590	8'6"	2590	8'6"	2590	8'6"	2390	7'10"

*Varies with stick length.

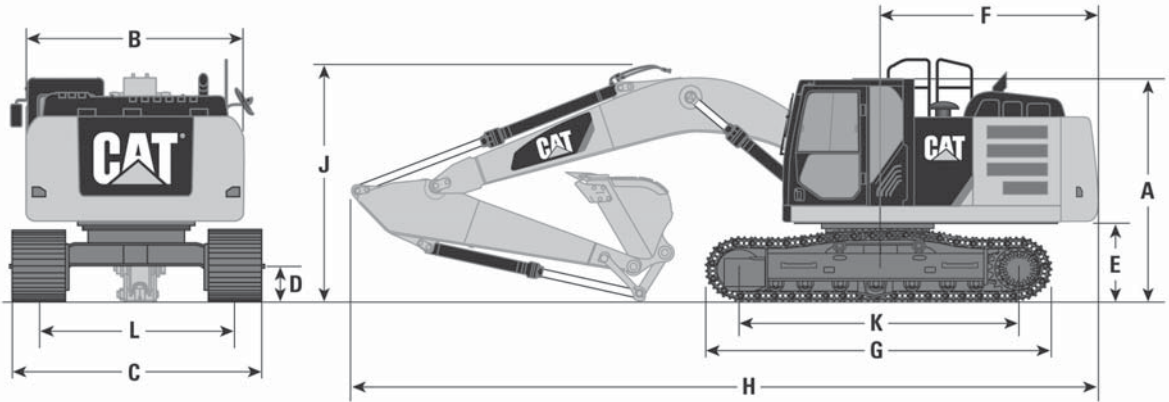

Region Offerings	329E Reach		329E Mass		329E L Reach**		329E L Mass***	
	Japan		Japan		North America		North America	
	mm	ft	mm	ft	mm	ft	mm	ft
A	3044	10'0"	3044	10'0"	3044	10'0"	3044	10'0"
B	2934	9'8"	2934	9'8"	2934	9'8"	2934	9'8"
C	3090	10'2"	3090	10'2"	3390	11'1"	3390	11'1"
D	490	1'7"	490	1'7"	490	1'7"	490	1'7"
E	1134	3'9"	1134	3'9"	1134	3'9"	1134	3'9"
F	3044	10'0"	3044	10'0"	3044	10'0"	3044	10'0"
G	4351	14'3"	4351	14'3"	4860	15'11"	4860	15'11"
H*	10 386	34'1"	9830	32'3"	10 386	34'1"	9830	32'3"
J*	3372	11'1"	3520	11'7"	3372	11'1"	3520	11'7"
K	3490	11'5"	3490	11'5"	3994	13'1"	3994	13'1"
L	2390	7'10"	2390	7'10"	2590	8'6"	2590	8'6"

*Varies with stick length.

**R3.2 (10'6") stick and 800 mm (32") shoes.

***M2.5 (8'2") stick and 600 mm (24") shoes.

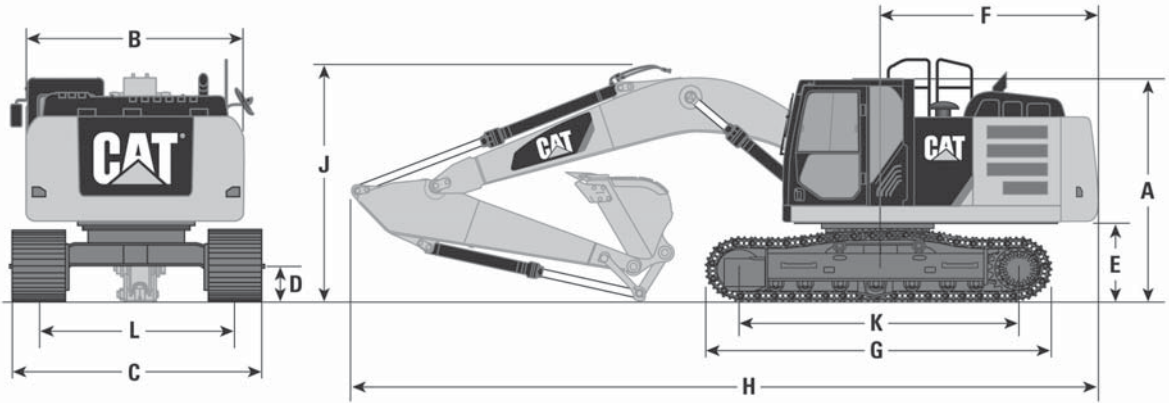

Region Offerings	329E L Reach**		329E L Mass***		329E LN Reach		329E LN Mass	
	Europe		Europe		Europe		Europe	
	mm	ft	mm	ft	mm	ft	mm	ft
A	3044	10'0"	3044	10'0"	3044	10'0"	3044	10'0"
B	2934	9'8"	2934	9'8"	2930	9'8"	2930	9'8"
C	3190	10'10"	3190	10'10"	2990	9'10"	2990	9'10"
D	490	1'7"	490	1'7"	490	1'7"	490	1'7"
E	1134	3'9"	1134	3'9"	1134	3'9"	1134	3'9"
F	3044	10'0"	3044	10'0"	3044	10'0"	3044	10'0"
G	4855	15'11"	4855	15'11"	4855	15'11"	4855	15'11"
H*	10 386	34'1"	9830	32'3"	10 386	34'1"	9830	32'3"
J*	3372	11'1"	3520	11'7"	3372	11'1"	3520	11'7"
K	3994	13'1"	3994	13'1"	3994	13'1"	3994	13'1"
L	2590	8'6"	2590	8'6"	2390	7'10"	2390	7'10"

*Varies with stick length.

**R3.2 (10'6") stick and 600 mm (24") shoes.

***M2.5 (8'2") stick and 600 mm (24") shoes.

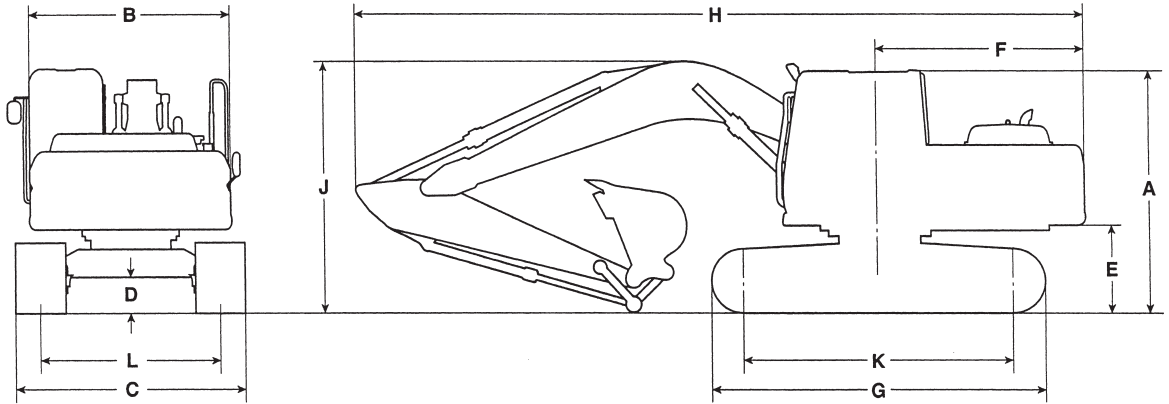

330D2 L Reach

Region Offerings	South America, Middle East, Africa, CIS, Asia Pacific, China	
	mm	ft
A	3040	10'0"
B	2900	9'6"
C	3390	11'1"
D	490	1'7"
E	1110	3'8"
F	3080	10'1"
G	4860	15'11"
H*	10 410	34'2"
J*	3180	10'5"
K	3990	13'1"
L	2590	8'6"

*Varies with stick length.

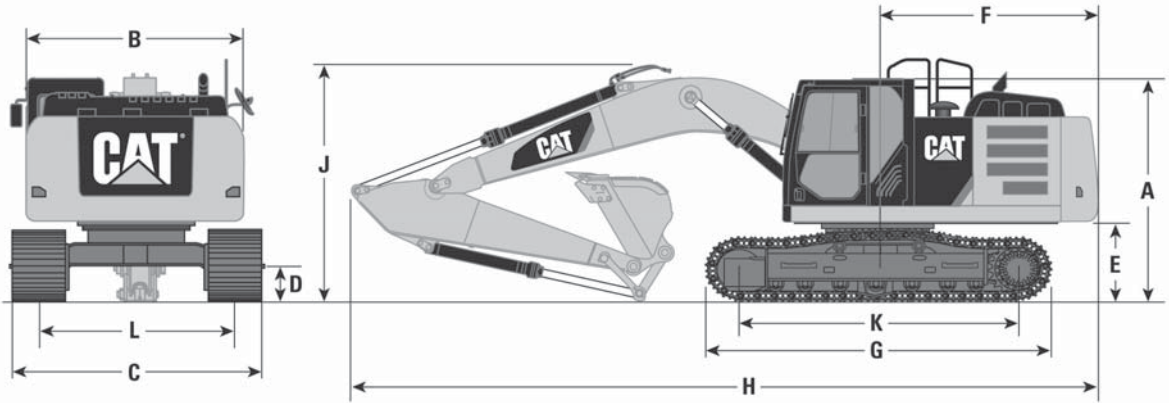

Region Offerings	330F Reach		330F Mass		330F L Reach		330F L SLR	
	Japan		Japan		Japan, North America, Europe		Japan, North America, Europe	
	mm	ft	mm	ft	mm	ft	mm	ft
A	3044	10'0"	3044	10'0"	3044	10'0"	3044	10'0"
B	2934	9'8"	2934	9'8"	2934	9'8"	2934	9'8"
C	3090	10'2"	3090	10'2"	3190	10'6"	3190	10'6"
D	490	1'7"	490	1'7"	490	1'7"	490	1'7"
E	1134	3'9"	1134	3'9"	1134	3'9"	1134	3'9"
F	3044	10'0"	3044	10'0"	3044	10'0"	3044	10'0"
G	4351	14'3"	4351	14'3"	4860	15'11"	4860	15'11"
H*	10 386	34'1"	9830	32'3"	10 386	34'1"	14 440	47'5"
J*	3372	11'1"	3520	11'7"	3372	11'1"	3230	10'7"
K	3490	11'5"	3490	11'5"	3990	13'1"	3990	13'1"
L	2390	7'10"	2390	7'10"	2590	8'6"	2590	8'6"

*Varies with stick length.

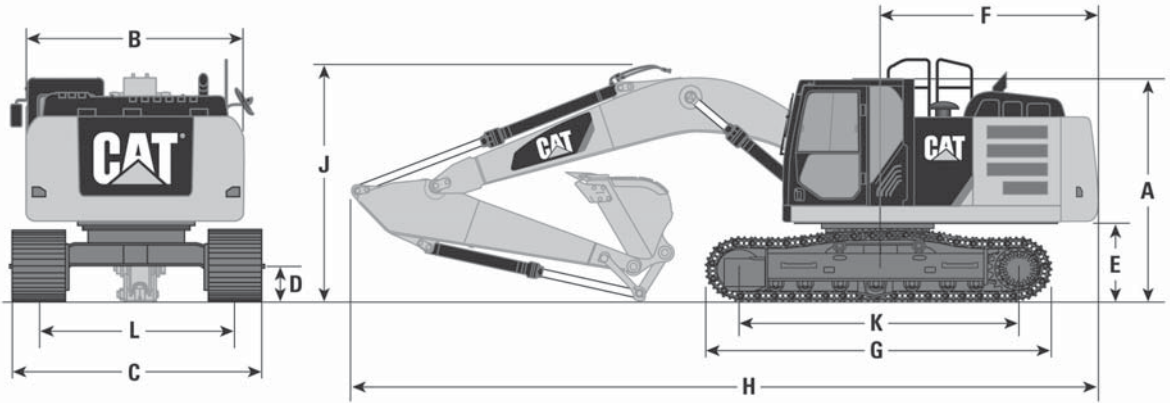

Region Offerings	330F LN Reach		335F L Reach		335F L Reach	
	Europe		North America**		Europe***	
	mm	ft	mm	ft	mm	ft
A	3044	10'0"	3260	10'8"	3260	10'8"
B	2930	9'8"	3540	11'7"	3540	11'7"
C	2990	9'10"	3440	11'3"	3190	10'6"
D	480	1'7"	480	1'7"	480	1'7"
E	1134	3'9"	1200	3'11"	1200	3'11"
F	3044	10'0"	1900	6'3"	1900	6'3"
G	4855	15'11"	5020	16'6"	5020	16'6"
H*	10 386	34'1"	9820	32'3"	9830	32'3"
J*	3372	11'1"	3540	11'7"	3540	11'7"
K	3994	13'1"	4040	13'3"	4040	13'3"
L	2390	7'10"	2590	1'7"	2590	1'7"

*Varies with stick length.

**HD R3.2CB2 (10'6") stick and 850 mm (33") shoes.

***HD R2.65CB2 (8'8") stick and 600 mm (24") shoes.

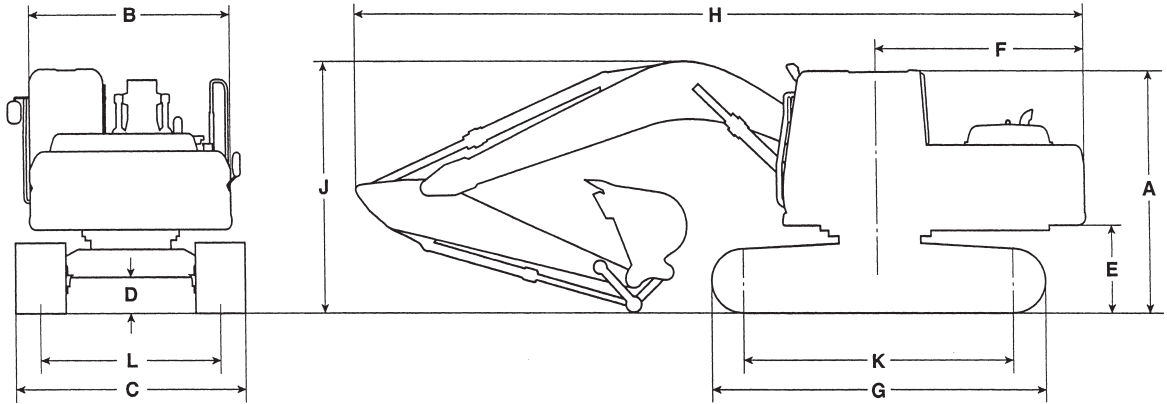

Region Offerings	336D2 Reach**		336D2 Mass**		336D2 L Reach		336D2 L Mass	
	Asia Pacific		Asia Pacific		Asia Pacific, South America, Middle East, Africa		Asia Pacific, South America, Middle East, Africa	
	mm	ft	mm	ft	mm	ft	mm	ft
A	3140	10'4"	3140	10'4"	3140	10'4"	3140	10'4"
B	2960	9'9"	2960	9'9"	2960	9'9"	2960	9'9"
C	3190	10'6"	3190	10'6"	3390	11'1"	3390	11'1"
D	450	1'6"	450	1'6"	450	1'6"	450	1'6"
E	1220	4'0"	1220	4'0"	1220	4'0"	1220	4'0"
F	3500	11'6"	3500	11'6"	3500	11'6"	3500	11'6"
G	4590	15'1"	4590	15'1"	5020	16'6"	5020	16'6"
H*	11 200	36'9"	10 910	35'10"	11 200	36'9"	10 910	35'10"
J*	3700	12'2"	3650	12'0"	3700	12'2"	3650	12'0"
K	3610	11'10"	3610	11'10"	4040	13'3"	4040	13'3"
L	2590	8'6"	2590	8'6"	2590	8'6"	2590	8'6"

*Varies with stick length.

**600 mm (24") shoes.

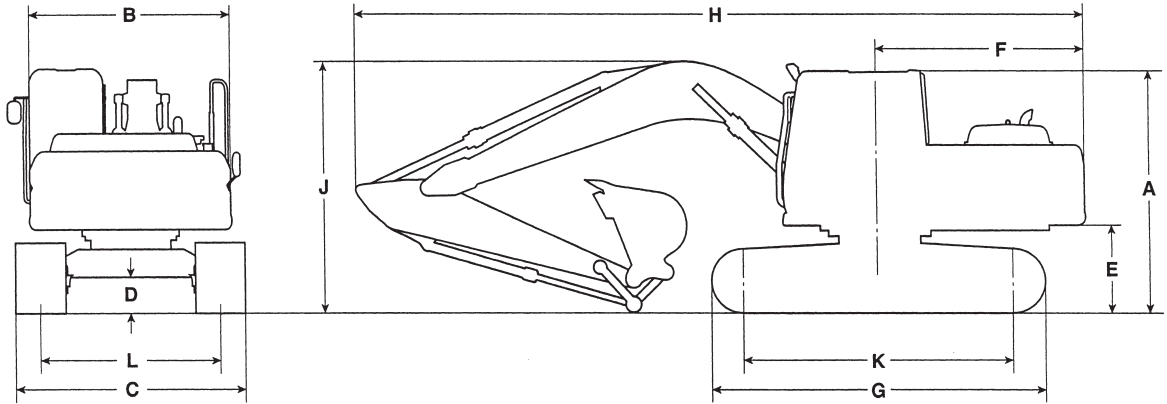

Region Offerings	336D2 GC**		336D2 XE**		336D2 L XE***	
	China		China, S.E. Asia		S.E. Asia, South America, Africa, Middle East, CIS	
	mm	ft	mm	ft	mm	ft
A	3140	10'4"	3140	10'4"	3140	10'4"
B	2960	9'6"	2960	9'6"	2960	9'6"
C	3190	10'6"	3190	10'6"	3290	10'10"
D	480	1'7"	480	1'7"	480	1'7"
E	1220	4'0"	1220	4'0"	1220	4'0"
F	3500	11'6"	3500	11'6"	3500	11'6"
G	4590	15'1"	4590	15'1"	5020	16'6"
H*	11 230	36'10"	10 890	35'9"	10 890	35'9"
J*	3640	11'11"	3600	11'10"	3600	11'10"
K	3610	11'10"	3610	11'10"	4040	13'3"
L	2590	8'6"	2590	8'6"	2590	8'6"

*Varies with stick length.

**R2.8 (9'2") stick and 600 mm (24") shoes.

***M2.55 (8'4") stick and 700 mm (28") shoes.

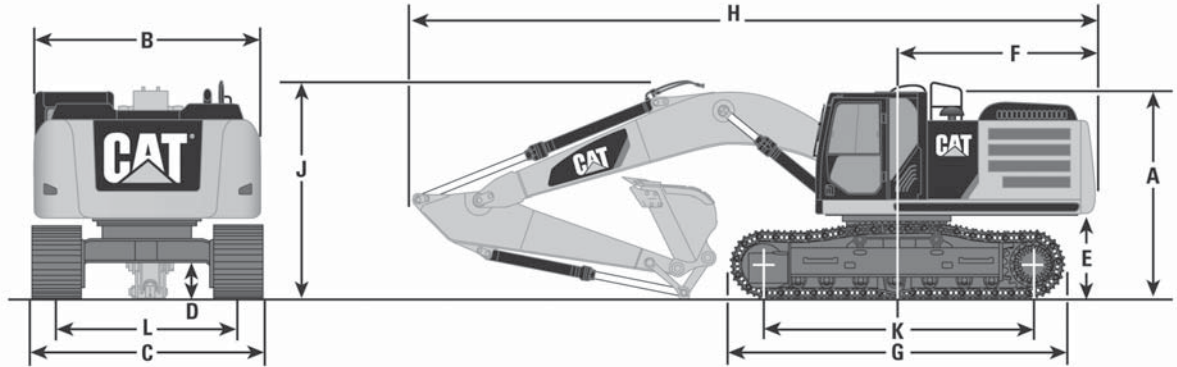

Region Offerings	336E Reach**		336E Mass***		336E L Reach****		336E L Mass*****	
	Japan		Japan		North America		North America	
	mm	ft	mm	ft	mm	ft	mm	ft
A	3360	11'0"	3360	11'0"	3360	11'0"	3360	11'0"
B	2982	9'8"	2982	9'8"	2982	9'8"	2982	9'8"
C	3190	10'6"	3190	10'6"	3440	11'3"	3440	11'3"
D	480	1'7"	480	1'7"	480	1'7"	480	1'7"
E	1220	4'0"	1220	4'0"	1220	4'0"	1220	4'0"
F	3460	11'4"	3460	11'4"	3460	11'4"	3460	11'4"
G	4590	15'1"	4590	15'1"	5020	16'6"	5020	16'6"
H*	11 160	36'7"	10 890	35'9"	11 170	36'8"	10 890	35'9"
J*	3510	11'6"	3600	11'10"	3660	12'0"	3600	11'10"
K	3605	11'10"	3605	11'10"	4040	13'3"	4040	13'3"
L	2590	8'6"	2590	8'6"	2590	8'6"	2590	8'6"

*Varies with stick length.
 **R3.2 (10'6") stick and 600 mm (24") shoes.
 ***M2.55 (8'4") stick and 600 mm (24") shoes.
 ****R3.9 (12'10") stick and 850 mm (34") shoes.
 *****M2.55 (8'4") stick and 850 mm (34") shoes.

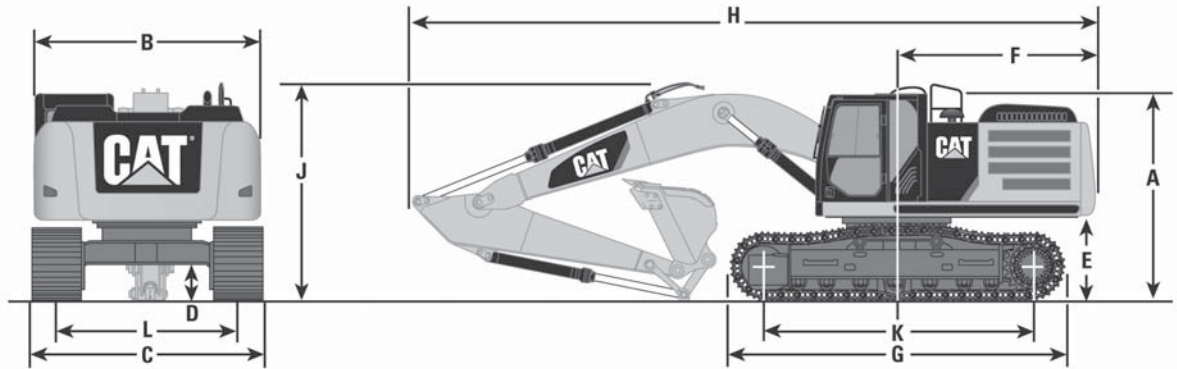

Region Offerings	336E L Reach**		336E L Mass***		336E LN Reach****		336E LN Mass*****	
	Europe		Europe		Europe		Europe	
	mm	ft	mm	ft	mm	ft	mm	ft
A	3360	11'0"	3360	11'0"	3360	11'0"	3360	11'0"
B	2982	9'8"	2982	9'8"	2982	9'8"	2982	9'8"
C	3290	10'10"	3290	10'10"	2990	9'10"	2990	9'10"
D	480	1'7"	480	1'7"	480	1'7"	480	1'7"
E	1220	4'0"	1220	4'0"	1220	4'0"	1220	4'0"
F	3460	11'4"	3460	11'4"	3460	11'4"	3460	11'4"
G	5020	16'6"	5020	16'6"	5020	16'6"	5020	16'6"
H*	11 160	36'7"	10 890	35'9"	11 160	36'7"	10 890	35'9"
J*	3510	11'6"	3600	11'10"	3510	11'6"	3600	11'10"
K	4040	13'3"	4040	13'3"	4040	13'3"	4040	13'3"
L	2590	8'6"	2590	8'6"	2390	7'10"	2390	7'10"

*Varies with stick length.

**R3.2 (10'6") stick and 700 mm (28") shoes.

***M2.55 (8'4") stick and 700 mm (28") shoes.

****R3.2 (10'6") stick and 600 mm (24") shoes.

*****M2.55 (8'4") stick and 600 mm (24") shoes.

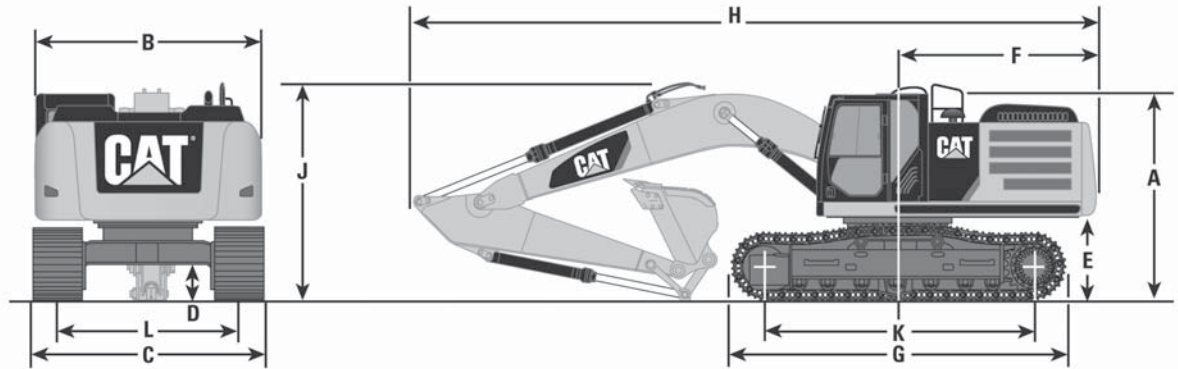

Region Offerings	336E L H Reach**		336E L H Reach***		336E LN H Reach****	
	North America		Europe, Japan		Europe	
	mm	ft	mm	ft	mm	ft
A	3360	11'0"	3360	11'0"	3360	11'0"
B	2982	9'8"	2982	9'8"	2982	9'8"
C	3440	11'3"	3290	10'10"	2990	9'10"
D	480	1'7"	480	1'7"	480	1'7"
E	1220	4'0"	1220	4'0"	1220	4'0"
F	3490	11'5"	3490	11'5"	3490	11'5"
G	5020	16'6"	5020	16'6"	5020	16'6"
H*	11 170	36'8"	11 160	36'7"	11 160	36'7"
J*	3660	12'0"	3510	11'6"	3510	11'6"
K	4040	13'3"	4040	13'3"	4040	13'3"
L	2590	8'6"	2590	8'6"	2390	7'10"

*Varies with stick length.
 **R3.9 (12'10") stick and 850 mm (34") shoes.
 ***R3.2 (10'6") stick and 700 mm (28") shoes.
 ****R3.2 (10'6") stick and 600 mm (24") shoes.

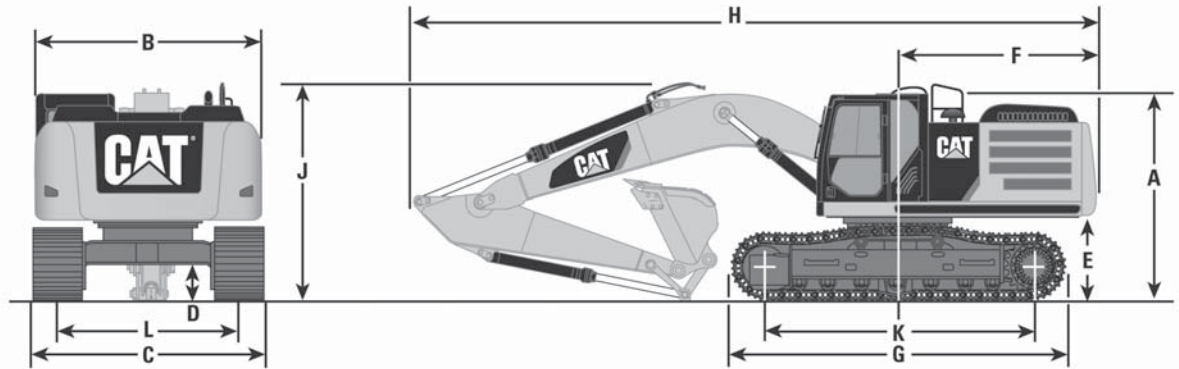

Region Offerings	336F L**		336F LN***		336F L XE**		336F LN XE***	
	North America		Europe		North America, Europe		Europe	
	mm	ft	mm	ft	mm	ft	mm	ft
A	3150	10'4"	3150	10'4"	3150	10'4"	3150	10'4"
B	2990	9'10"	2990	9'10"	2990	9'10"	2990	9'10"
C	3440	11'3"	2990	9'10"	3440	11'3"	2990	9'10"
D	480	1'7"	480	1'7"	480	1'7"	480	1'7"
E	1220	4'0"	1220	4'0"	1220	4'0"	1220	4'0"
F	3470	11'5"	3470	11'5"	3470	11'5"	3470	11'5"
G	5030	16'6"	5030	16'6"	5030	16'6"	5030	16'6"
H*	11 170	36'8"	11 160	36'7"	11 170	36'8"	11 160	36'7"
J*	3660	12'0"	3510	11'6"	3660	12'0"	3510	11'6"
K	4040	13'3"	4040	13'3"	4040	13'3"	4040	13'3"
L	2590	8'6"	2390	7'10"	2590	8'6"	2390	7'10"

*Varies with stick length.

**R3.9 (12'10") stick and 850 mm (33") shoes.

***R3.2 (10'6") stick and 600 mm (24") shoes.

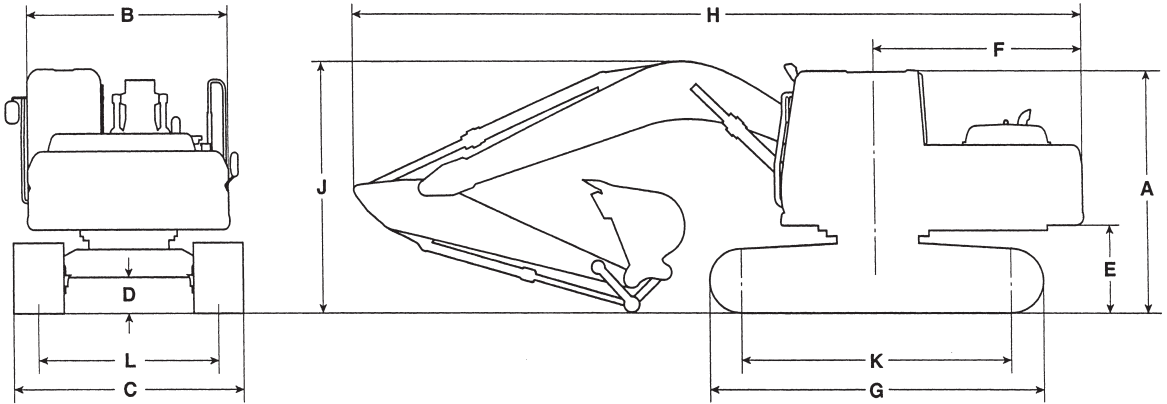

340D2 L**

Region Offerings	China, S.E. Asia, South America except Brazil, Africa, Middle East, CIS	
	mm	ft
A	3360	11'0"
B	2960	9'6"
C	3190	10'6"
D	690	2'3"
E	1450	4'9"
F	3490	11'5"
G	5060	16'7"
H*	10 900	35'9"
J*	3780	12'5"
K	4040	13'3"
L	2920	9'7"

*Varies with stick length.

**M2.55 (8'4") stick and 600 mm (24") shoes.

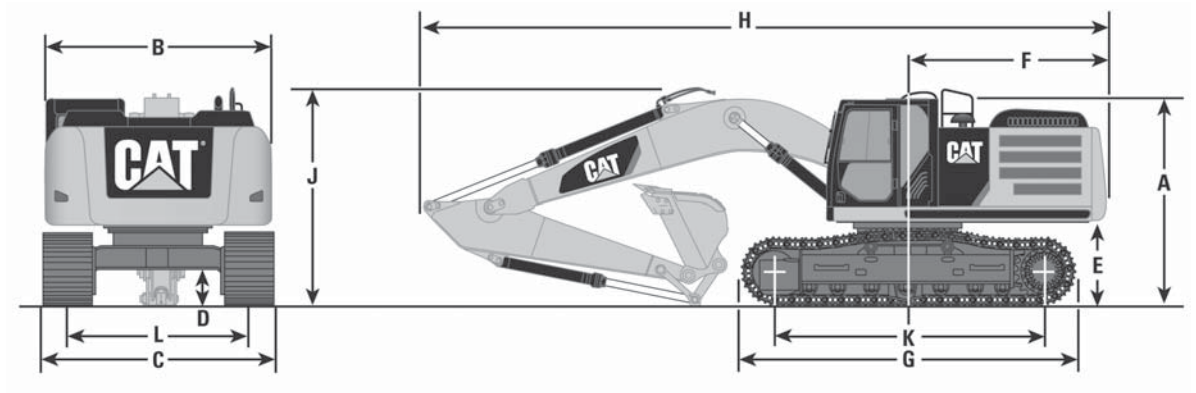

340F L**

Region Offerings	Europe	
	mm	ft
A	3390	11'1"
B	2990	9'10"
C	3520	11'7"
D	720	2'4"
E	1450	4'9"
F	3470	11'5"
G	5020	16'6"
H*	11 080	36'4"
J*	3450	11'4"
K	4040	13'3"
L	2920	9'7"

*Varies with stick length.

**R3.2 (10'6") stick and 600 mm (24") shoes.

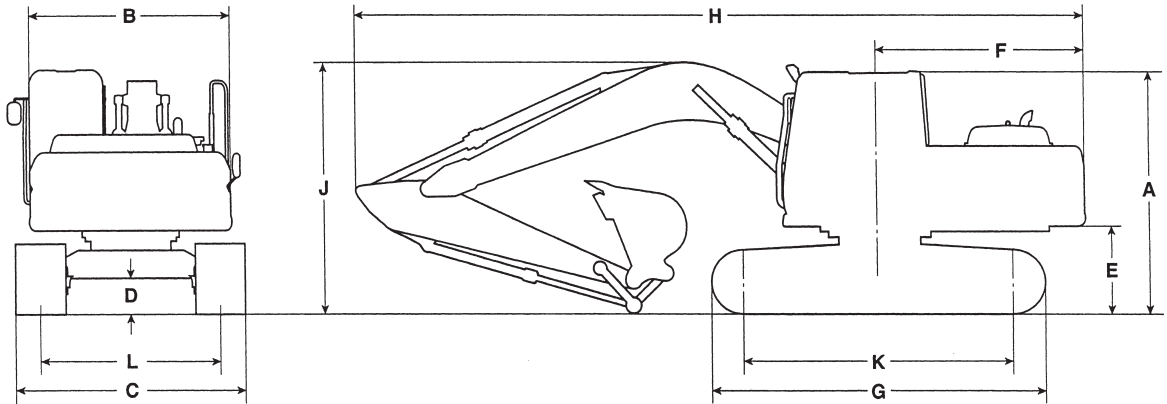

349D2 – FIX Reach

349D2 L – FIX Mass

Region Offerings	Asia Pacific, CIS		South America, Asia Pacific, Middle East, Africa, CIS, New Zealand, Australia	
	mm	ft	mm	ft
A***	3210	10'6"	3210	10'6"
B****	2962	9'8"	2962	9'8"
C**	3640	11'11"	3640	11'11"
D	510	1'8"	510	1'8"
E	1320	4'4"	1320	4'4"
F	3770	12'4"	3770	12'4"
G	5070	16'8"	5360	17'7"
H*	11 950	39'2"	11 710	38'5"
J*	3660	12'0"	3960	13'0"
K	4030	13'3"	4360	14'4"
L	2740	9'0"	2740	9'0"

*Varies with stick length.
 **Transport position — 900 mm (36") track shoes.
 ***Without Falling Object Guard (FOG).
 ****No mirror or handrail.

Medium stick is available all models.
 Undercarriage is retracted.

Hydraulic Excavators

Shipping Dimensions

● 349E ● 349F L ● 349F L XE

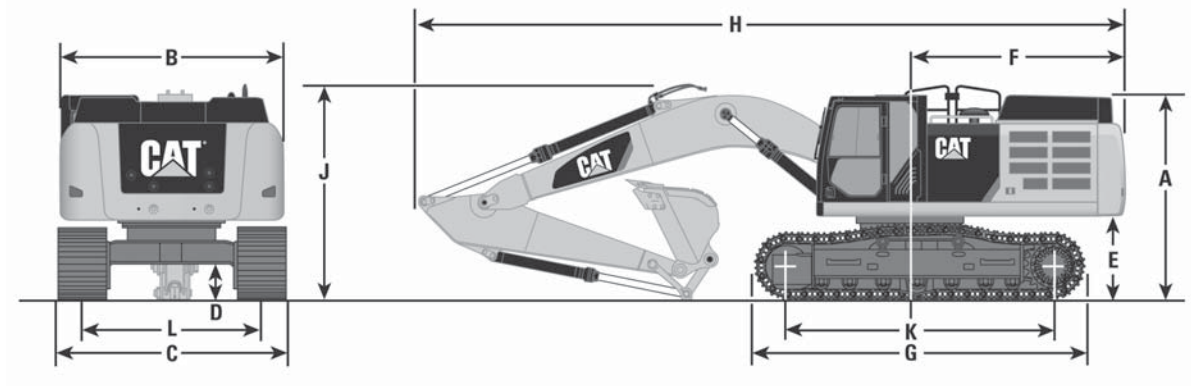

Region Offerings	349E – FIX Reach**		349F L**		349F L – FIX***		349F L XE***	
	Japan		North America		North America		North America	
	mm	ft	mm	ft	mm	ft	mm	ft
A	3220	10'7"	3220	10'7"	3220	10'7"	3220	10'7"
B	2990	9'10"	2990	9'10"	3000	9'10"	2990	9'10"
C	3340	11'0"	3490	11'5"	3640	11'11"	3790	12'5"
D	510	1'8"	480	1'7"	510	1'8"	480	1'7"
E	1280	4'2"	1280	4'2"	1280	4'2"	1280	4'2"
F	3760	12'4"	3760	12'4"	3760	12'4"	3760	12'4"
G	5040	16'6"	5370	17'7"	5370	17'7"	5370	17'7"
H*	11 920	39'1"	11 920	39'1"	11 930	39'2"	11 930	39'2"
J*	3730	12'3"	3730	12'3"	3670	12'0"	3670	12'
K	4030	13'3"	4360	14'4"	4360	14'4"	4360	14'4"
L	2740	9'0"	2740	9'0"	2740	9'0"	2740	9'0"

*Varies with stick length.

**R3.35 (11'0") stick and 600 mm (24") shoes.

***R3.9 (12'10") stick and 900 mm (35") shoes.

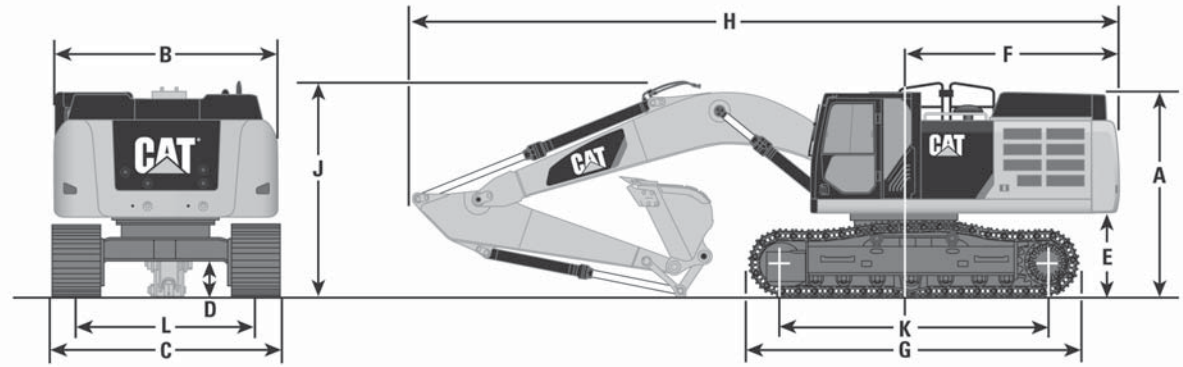

7

Region Offerings	352F**		352F – VG***		352F XE****	
	North America		North America		Europe	
	mm	ft	mm	ft	mm	ft
A	3370	11'1"	3370	11'1"	3370	11'1"
B	2990	9'10"	3000	9'10"	2990	9'10"
C	3490	11'5"	3790	12'5"	3490	11'5"
D	710	2'4"	740	2'5"	710	2'4"
E	1430	4'8"	1430	4'8"	1430	4'8"
F	3760	12'4"	3760	12'4"	3760	12'4"
G	5380	12'8"	5380	17'8"	5380	12'8"
H*	11 820	38'9"	11 890	39'0"	11 640	38'2"
J*	3550	11'8"	3650	12'0"	4010	13'2"
K	4340	14'3"	4340	14'3"	4340	14'3"
L	2890	9'6"	2890	9'6"	2740	9'0"

*Varies with stick length.
 **R3.35 (11'0") stick and 600 mm (24") shoes.
 ***R3.9 (12'10") stick and 900 mm (35") shoes.
 ****M2.5 (8'2") stick and 600 mm (24") shoes.

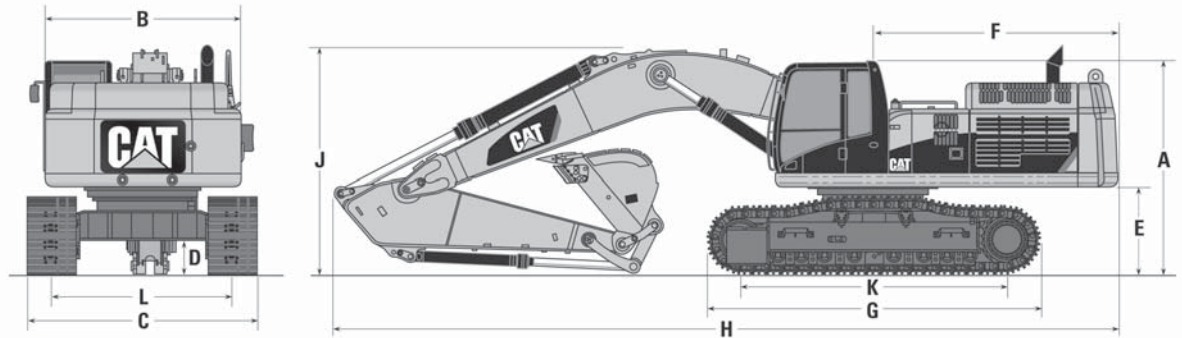

Region Offerings	374D L Reach**		374D L Reach***		374D L Mass****	
	World Wide		World Wide		World Wide	
	mm	ft	mm	ft	mm	ft
A	3540	11'7"	3540	11'7"	3540	11'7"
B	3450	11'3"	3450	11'3"	3450	11'3"
C	3500	11'6"	3500	11'6"	3500	11'6"
D	840	2'9"	840	2'9"	840	2'9"
E	1550	5'1"	1550	5'1"	1550	5'1"
F	4015	13'2"	4015	13'2"	4015	13'2"
G	5870	19'3"	5870	19'3"	5870	19'3"
H*	13 310	43'8"	13 320	43'8"	12 670	41'7"
J*	4620	15'2"	4480	14'8"	4610	15'1"
K	4705	15'5"	4705	15'5"	4705	15'5"
L	2750	9'0"	2750	9'0"	2750	9'0"

*Varies with stick length.

**R4.15 (13'7") stick and 750 mm (30") shoes.

***R3.6 (11'10") stick and 750 mm (30") shoes.

****M2.57 (8'5") stick and 750 mm (30") shoes.

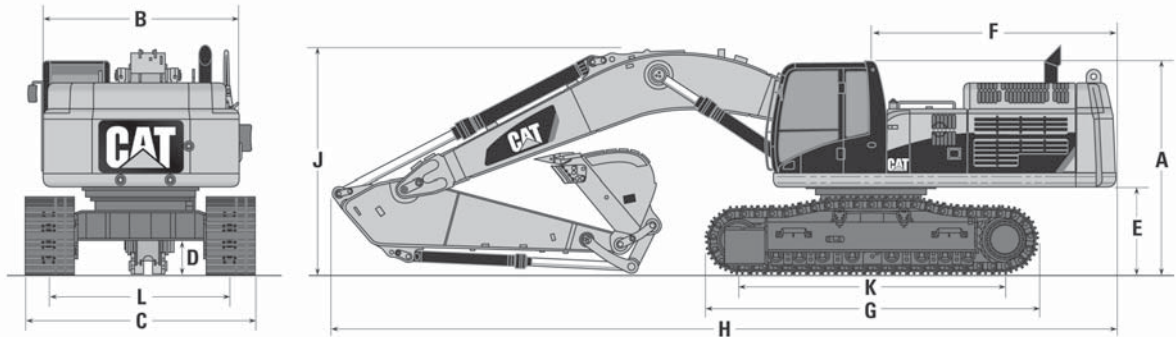

Region Offerings	374F L Reach**		374F L Reach***		374F L Reach****		374F L Reach*****		374F L Mass*****		374F L Mass*****	
	World Wide		World Wide		World Wide		World Wide		World Wide		World Wide	
	mm	ft	mm	ft	mm	ft	mm	ft	mm	ft	mm	ft
A	3970	13'0"	3970	13'0"	3970	13'0"	3970	13'0"	3970	13'0"	3970	13'0"
B	3450	11'4"	3450	11'4"	3450	11'4"	3450	11'4"	3450	11'4"	3450	11'4"
C	4340	14'3"	4340	14'3"	4340	14'3"	4340	14'3"	4340	14'3"	4340	14'3"
D	840	2'9"	840	2'9"	840	2'9"	840	2'9"	840	2'9"	840	2'9"
E	1540	5'1"	1540	5'1"	1540	5'1"	1540	5'1"	1540	5'1"	1540	5'1"
F	4015	13'2"	4015	13'2"	4015	13'2"	4015	13'2"	4015	13'2"	4015	13'2"
G	5870	19'3"	5870	19'3"	5870	19'3"	5870	19'3"	5870	19'3"	5870	19'3"
H*	13 230	43'5"	13 310	43'8"	13 330	43'9"	13 430	44'1"	12 620	41'5"	12 660	41'6"
J*	4990	16'5"	4650	15'3"	4520	14'10"	4300	14'1"	4720	15'6"	4630	15'2"
K	4705	15'5"	4705	15'5"	4705	15'5"	4705	15'5"	4705	15'5"	4705	15'5"
L	3410	11'2"	3410	11'2"	3410	11'2"	3410	11'2"	3410	11'2"	3410	11'2"

*Varies with stick length.

**R4.67 (15'4") stick and 900 mm (35") shoe with 3.8 m³ (5.0 yd³) bucket.

***R4.15 (13'7") stick and 900 mm (35") shoe with 3.8 m³ (5.0 yd³) bucket.

****R3.6 (11'10") stick and 900 mm (35") shoe with 3.8 m³ (5.0 yd³) bucket.

*****R2.84 (9'4") stick and 900 mm (35") shoe with 3.8 m³ (5.0 yd³) bucket.

*****M3.00 (9'10") stick and 650 mm (26") shoe with 4.6 m³ (6.0 yd³) bucket.

*****M2.57 (8'5") stick and 650 mm (26") shoe with 4.6 m³ (6.0 yd³) bucket.

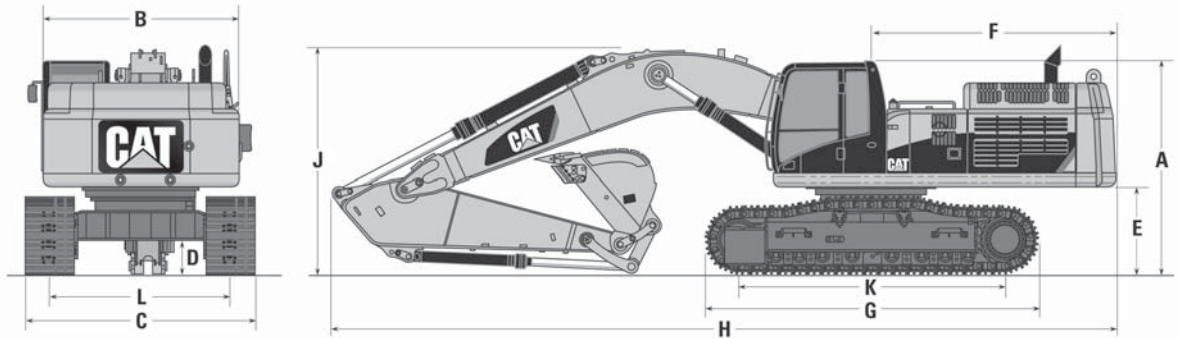

Region Offerings	390D L Reach**		390D L Reach***		390D L GP****		390D L Mass*****	
	World Wide		World Wide		World Wide		World Wide	
	mm	ft	mm	ft	mm	ft	mm	ft
A	3760	12.33'	3760	12.33'	3760	12.33'	3760	12.33'
B	3470	11.38'	3470	11.38'	3470	11.38'	3470	11.38'
C	4260	13.97'	4260	13.97'	4260	13.97'	4260	13.97'
D	900	2.95'	900	2.95'	900	2.95'	900	2.95'
E	1630	5.35'	1630	5.35'	1630	5.35'	1630	5.35'
F	4680	15.35'	4680	15.35'	4680	15.35'	4680	15.35'
G	6360	20.86'	6360	20.86'	6360	20.86'	6360	20.86'
H*	16 280	53.41'	16 320	53.54'	14 720	48.29'	13 690	44.91'
J*	5430	17.81'	5030	16.50'	5160	16.92'	4900	16.07'
K	5120	16.79'	5120	16.79'	5120	16.79'	5120	16.79'
L	2750	9.02'	2750	9.02'	2750	9.02'	2750	9.02'

*Varies with stick length.

**R5.5 (18'1") stick with HB3.9 m³ (5.1 yd³) bucket.

***R4.4 (14'5") stick with HB3.9 m³ (5.1 yd³) bucket.

****GP3.4 (11'2") stick with JC4.6 m³ (6.0 yd³) bucket.

*****M2.92 (9'7") stick with JC6.0 m³ (7.8 yd³) bucket.

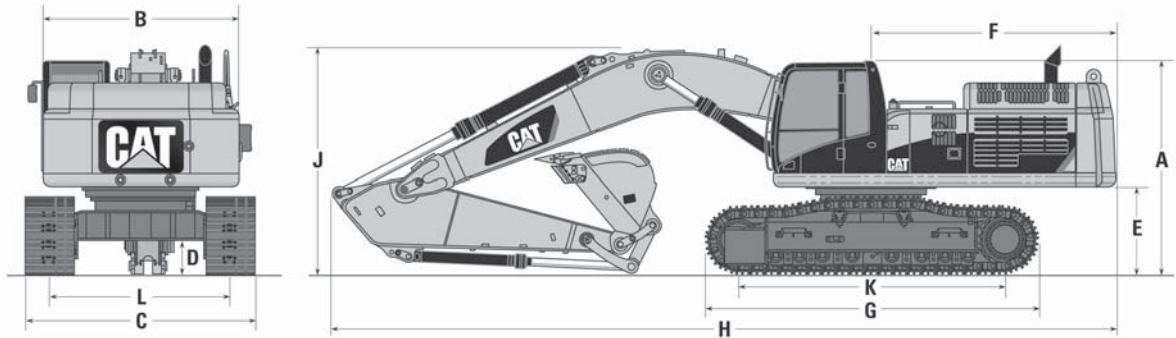

7

Region Offerings	390F L Reach**		390F L Reach***		390F L GP****		390F L GP*****		390F L GP*****	
	World Wide		World Wide		World Wide		World Wide		Japan	
	mm	ft	mm	ft	mm	ft	mm	ft	mm	ft
A	3830	12'7"	3830	12'7"	3830	12'7"	3830	12'7"	3830	12'7"
B	3470	11'5"	3470	11'5"	3470	11'5"	3470	11'5"	3470	11'5"
C	4260	14'0"	4260	14'0"	4260	14'0"	4260	14'0"	4260	14'0"
D	900	2'11"	900	2'11"	900	2'11"	900	2'11"	900	2'11"
E	1640	5'5"	1640	5'5"	1640	5'5"	1640	5'5"	1640	5'5"
F	4700	15'5"	4700	15'5"	4700	15'5"	4700	15'5"	4700	15'5"
G	6360	20'10"	6360	20'10"	6360	20'10"	6360	20'10"	6360	20'10"
H*	16 290	53'5"	16 330	53'7"	14 500	47'7"	14 690	48'2"	14 710	48'3"
J*	5490	18'0"	5070	16'8"	5840	19'2"	5290	17'4"	5080	16'8"
K	5120	16'10"	5120	16'10"	5120	16'10"	5120	16'10"	5120	16'10"
L	3510	11'6"	3510	11'6"	3510	11'6"	3510	11'6"	3510	11'6"

*Varies with stick length.

**R5.5 (18'1") stick and 750 mm (30") shoe with 3.9 m³ (5.1 yd³) bucket.

***R4.4 (14'5") stick and 750 mm (30") shoe with 3.9 m³ (5.1 yd³) bucket.

****R5.5 (18'1") stick and 750 mm (30") shoe with 4.6 m³ (6.0 yd³) bucket.

*****R4.4 (14'5") stick and 750 mm (30") shoe with 4.6 m³ (6.0 yd³) bucket.

*****GP3.7 (12'2") stick and 750 mm (30") shoe with 4.6 m³ (6.0 yd³) bucket.

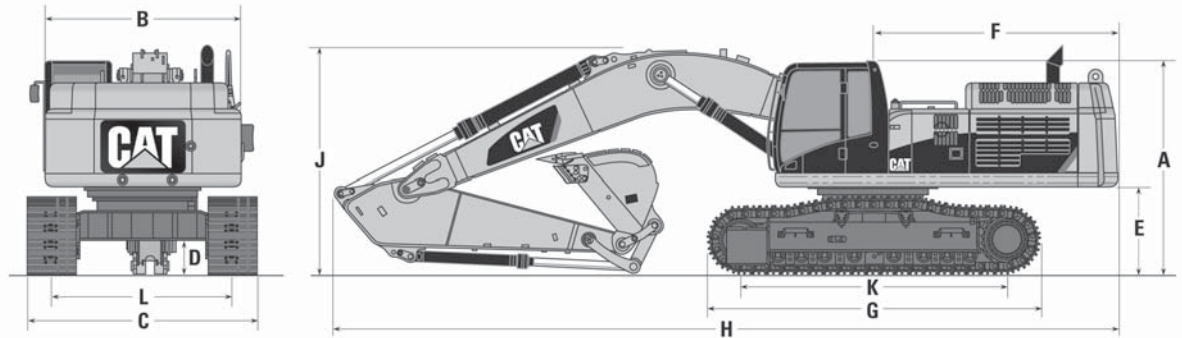

Region Offerings	390F L GP**		390F L GP***		390F L Mass****		390F L Mass*****	
	World Wide		World Wide		World Wide		World Wide	
	mm	ft	mm	ft	mm	ft	mm	ft
A	3830	12'7"	3830	12'7"	3830	12'7"	3830	12'7"
B	3470	11'5"	3470	11'5"	3470	11'5"	3470	11'5"
C	4260	14'0"	4260	14'0"	4260	14'0"	4260	14'0"
D	900	2'11"	900	2'11"	900	2'11"	900	2'11"
E	1640	5'5"	1640	5'5"	1640	5'5"	1640	5'5"
F	4700	15'5"	4700	15'5"	4700	15'5"	4700	15'5"
G	6360	20'10"	6360	20'10"	6360	20'10"	6360	20'10"
H*	14 720	48'4"	14 930	49'0"	13 550	44'6"	13 690	44'11"
J*	5160	16'11"	5000	16'5"	5310	17'5"	4890	16'1"
K	5120	16'10"	5120	16'10"	5120	16'10"	5120	16'10"
L	3510	11'6"	3510	11'6"	3510	11'6"	3510	11'6"

*Varies with stick length.

**GP3.4 (11'2") stick and 750 mm (30") shoe with 4.6 m³ (6.0 yd³) bucket.

***GP2.92 (9'7") stick and 750 mm (30") shoe with 4.6 m³ (6.0 yd³) bucket.

****M3.4 (11'2") stick and 750 mm (30") shoe with 6.0 m³ (7.84 yd³) bucket.

*****M2.92 (9'7") stick and 750 mm (30") shoe with 6.0 m³ (7.84 yd³) bucket.

Major Component Weights
 ● 300.9D ● 301.4C ● 301.7D ● 302.2D
 ● 302.4D ● 302.7D CR ● 303E CR ● 303.5E CR

**Hydraulic
Excavators**

	300.9D		301.4C		301.7D		302.2D	
Region Offerings	North America, South America, Canada, Australia, New Zealand, Europe, Africa, Middle East		North America, Canada, Australia, New Zealand, Europe, Africa, Middle East		North America, South America, Canada, Australia, New Zealand, Europe, Africa, Middle East		Europe, Africa, Middle East	
Buckets: (see data in bucket section)	kg	lb	kg	lb	kg	lb	kg	lb
Booms:**								
One-piece	—		—		—		—	
Sticks:**								
Medium Stick	—		—		—		—	
Long Stick	—		—		—		—	
Other:								
Upperstructure (complete w/o ctwt)	—		—		—		—	
Standard Undercarriage (std shoe)	—		—		—		—	
Counterweight — Standard	—		—		—		—	
Extra Counterweight	—		—		—		—	

*Boom weights include boom, boom lines, boom cylinders and rod end pins, stick cylinder, head end pin and stick lines.

**Stick weights include stick, stick lines, bucket cylinder, bucket cylinder pins and bucket linkage.

	302.4D		302.7D CR		303E CR		303.5E CR	
Region Offerings	North America, South America, Canada, Australia, New Zealand, Europe, Africa, Middle East		North America, South America, Canada, Australia, New Zealand, Europe, Africa, Middle East		North America, South America, Canada, Australia, New Zealand		North America, South America, Canada, Australia, New Zealand, Europe, Africa, Middle East	
Buckets: (see data in bucket section)	kg	lb	kg	lb	kg	lb	kg	lb
Booms:**								
One-piece	—		—		104	229	285	630
Sticks:**								
Medium Stick	—		—		53	117	58	130
Long Stick	—		—		60	132	77	170
Other:								
Upperstructure (complete w/o ctwt)	—		—		1837	4051	1057	2330
Standard Undercarriage (std shoe)	—		—		1039	2291	1046	2310
Counterweight — Standard	—		—		—		450	1101
Extra Counterweight	—		112	247	—		—	

*Boom weights include boom, boom lines, boom cylinders and rod end pins, stick cylinder, head end pin and stick lines.

**Stick weights include stick, stick lines, bucket cylinder, bucket cylinder pins and bucket linkage.

Hydraulic Excavators

Major Component Weights

- 303.5E2 CR ● 304E2 CR ● 305E2 CR
- 305.5E2 CR ● 307E2 ● 308E2 CR SB

Region Offerings	303.5E2 CR		304E2 CR		305E2 CR	
	North America, South America, Canada, Australia, New Zealand, Africa, Middle East		North America, South America, Canada, Australia, New Zealand, Europe, Africa, Middle East		North America, South America, Canada, Australia, New Zealand, Europe, Africa, Middle East	
Buckets: (see data in bucket section)	kg	lb	kg	lb	kg	lb
Booms:*						
One-piece	285	630	195	430	200	441
Sticks:**						
Medium Stick	58	130	95	210	90	198
Long Stick	88	194	127	280	135	298
Other:						
Upperstructure (complete w/o ctwt)	1057	2330	1342	2970	2890	6372
Standard Undercarriage (std shoe)	1046	2310	1059	2330	1650	3638
Counterweight — Standard	478	1054	505	1113	673	1484
Extra Counterweight	—	—	—	—	—	—

*Boom weights include boom, boom lines, boom cylinders and rod end pins, stick cylinder, head end pin and stick lines.

**Stick weights include stick, stick lines, bucket cylinder, bucket cylinder pins and bucket linkage.

Region Offerings	305.5E2 CR		307E2		308E2 CR SB	
	North America, South America, Canada, Australia, New Zealand, Europe, Africa, Middle East		North America, Canada, Europe		North America, Canada, Australia, New Zealand, Europe	
Buckets: (see data in bucket section)	kg	lb	kg	lb	kg	lb
Booms:*						
One-piece	215	474	545	1202	507	1115
Sticks:**						
Medium Stick	100	221	221	487	285	627
Long Stick	140	309	—	—	343	755
Other:						
Upperstructure (complete w/o ctwt)	3115	6869	2205	4861	3480	7656
Standard Undercarriage (std shoe)	1650	3638	2919	6435	2780	6116
Counterweight — Standard	896	1975	900	1984	880	1936
Extra Counterweight	165	364	—	—	251	553

*Boom weights include boom, boom lines, boom cylinders and rod end pins, stick cylinder, head end pin and stick lines.

**Stick weights include stick, stick lines, bucket cylinder, bucket cylinder pins and bucket linkage.

Major Component Weights
 ● 311F L RR ● 312D2 ● 312D2 GC ● 312D2 L
 ● 312E ● 312E L ● 312F GC ● 313D2

**Hydraulic
Excavators**

	311F L RR		312D2		312D2 GC		312D2 L	
Region Offerings	North America, Europe, Australia, New Zealand and Polynesia, Japan		Asia Pacific		China		Africa, CIS, Asia Pacific, South America	
Buckets: (see data in bucket section)	kg	lb	kg	lb	kg	lb	kg	lb
Booms:*								
One-piece Reach	930	2050	1030	2270	1030	2270	1030	2270
Sticks:**								
Medium Stick	530	1170	570	1260	570	1260	570	1260
Long Stick	610	1350	—	—	—	—	—	—
Extra Long Stick	—	—	650	1430	—	—	650	1430
Other:								
Upperstructure (complete w/o ctwt)	4050	8930	4490	9900	4490	9900	4490	9900
Standard Undercarriage (std shoe)	—	—	(500 mm/20 in) 3860	8510	(500 mm/20 in) 3860	8510	—	—
Long Undercarriage (std shoe)	(500 mm/20 in) 3890	8580	—	—	—	—	(500 mm/20 in) 4150	9150
Counterweight:								
Standard	2150	4740	2450	5400	2100	4630	2450	5400
Heavy	2450	5400	2650	5840	—	—	2650	5840

*Boom weights include boom, boom lines, boom cylinders and rod end pins, stick cylinder, head end pin and stick lines.

**Stick weights include stick, stick lines, bucket cylinder, bucket cylinder pins and bucket linkage.

7

	312E		312E L		312F GC		313D2	
Region Offerings	Europe, Australia, New Zealand and Polynesia, Japan		North America, Europe, Australia, New Zealand and Polynesia		Japan		China, Asia Pacific	
Buckets: (see data in bucket section)	kg	lb	kg	lb	kg	lb	kg	lb
Booms:*								
One-piece Reach	1010	2230	1010	2230	1030	2270	1220	2690
VA Boom	1740	3836	1740	3836	—	—	—	—
Sticks:**								
Short Stick	490	1080	490	1080	—	—	—	—
Medium Stick	480	1060	480	1060	570	1260	640	1410
Intermediate Stick	530	1170	—	—	—	—	—	—
Long Stick	560	1230	560	1230	650	1430	—	—
Extra Long Stick	—	—	—	—	—	—	—	—
Other:								
Upperstructure (complete w/o ctwt)	5120	11,290	5120	11,290	4420	9750	4490	9900
Standard Undercarriage (std shoe)	3840	8470	—	—	(500 mm/20 in) 2500	5510	(500 mm/20 in) 4020	8860
Long Undercarriage (std shoe)	—	—	4160	9170	—	—	—	—
Counterweight — Standard	2200	4850	2200	4850	2100	4630	2450	5400

*Boom weights include boom, boom lines, boom cylinders and rod end pins, stick cylinder, head end pin and stick lines.

**Stick weights include stick, stick lines, bucket cylinder, bucket cylinder pins, bucket linkage and stick nose pin.

Hydraulic Excavators

Major Component Weights

- 313D2 LGP ● 313F L GC ● 314E CR ● 314E LCR
- 316E L ● 318D2 L ● 318E L

Region Offerings	313D2 LGP		313F L GC		314E CR		314E LCR	
	Asia Pacific		North America, Europe, Turkey		Australia, New Zealand and Polynesia, Japan		North America, Europe, Australia, New Zealand and Polynesia, Japan	
Buckets: (see data in bucket section)	kg	lb	kg	lb	kg	lb	kg	lb
Booms:*								
One-piece Reach	1220	2690	1030	2270	1040	2290	1040	2290
Offset Boom	—	—	—	—	1730	3810	1730	3810
VA Boom	—	—	—	—	1800	3970	1800	3970
Sticks:**								
Medium Stick	640	1410	570	1260	570	1260	570	1260
Long Stick	—	—	650	1430	620	1370	620	1370
Extra Long Stick	650	1430	—	—	650	1430	650	1430
Other:								
Upperstructure (complete w/o ctwt)	4660	10,280	4420	9750	5040	11,110	5040	11,110
Standard Undercarriage (std shoe)	(960 mm/38 in)	7770	17,130	—	—	(500 mm/20 in)	—	—
Long Undercarriage (std shoe)	—	—	(700 mm/28 in)	—	—	(500 mm/20 in)	—	—
Counterweight:								
Light	—	—	—	—	2190	4830	—	—
Standard	1100	2430	—	—	—	—	3060	6750
Heavy	—	—	2450	5400	—	—	3560	7850

*Boom weights include boom, boom lines, boom cylinders and rod end pins, stick cylinder and head end pin.

**Stick weights include stick, stick lines, bucket cylinder, bucket cylinder pins, bucket linkage and stick nose pin.

Region Offerings	316E L		318D2 L		318E L	
	North America, Europe, Australia, New Zealand and Polynesia, Japan		Middle East, Africa, CIS, South America, Asia Pacific, China		North America, Europe, Australia, New Zealand and Polynesia	
Buckets: (see data in bucket section)	kg	lb	kg	lb	kg	lb
Booms:*						
One-piece Reach	1320	2910	1270	2800	1500	3310
HD Boom	—	—	1530	3370	—	—
VA Boom (France sourced only†)	1850	4080	—	—	1900	4190
Sticks:**						
Short Stick	810	1790	—	—	880	1940
Medium Stick	840	1850	780	1720	910	2010
Intermediate Stick	910	2010	—	—	—	—
HD Stick	—	—	880	1940	—	—
Long Stick	930	2050	850	1870	970	2140
Extra Long Stick	—	—	—	—	1000	2210
Other:						
Upperstructure (complete w/o ctwt)	5720	12,610	5330	11,750	5900	12,860
Long Undercarriage (std shoe)	5960	13,140	(600 mm/24 in)	—	6410	14,140
Counterweight — Standard	2800	6170	6090	13,430	3170	6990
			3170	6990	3400	7500

*Boom weights include boom, boom lines, boom cylinders and rod end pins, stick cylinder and head end pin.

**Stick weights include stick, stick lines, bucket cylinder, bucket cylinder pins, bucket linkage and stick nose pin.

● M313D ● M315D ● M315D2 ● M316D ● M317D2
● M318D ● M320D2 ● M322D ● M322D2

**Hydraulic
Excavators**

	M313D		M315D		M315D2		M316D		M317D2	
	kg	lb	kg	lb	kg	lb	kg	lb	kg	lb
Buckets: (see data in bucket section)										
Booms:*										
One-piece Boom	1250	2756	1530	3374	1250	2756	1560	3440	1530	3374
Hydraulically Adjustable Boom	1695	3737	2020	4454	1695	3737	2050	4520	2020	4454
Sticks:**										
Short Stick	370	816	470	1036	370	816	470	1036	470	1036
Medium Stick	390	860	514	1133	390	860	514	1133	514	1133
Long Stick	440	970	530	1169	440	970	530	1169	530	1169
Other:										
Upperstructure (with swing bearing, no boom)	7065	15,578	8126	17,918	7065	15,578	9296	20,498	8126	17,918
Undercarriage (with standard tires)	3500	7718	3890	8577	3500	7718	4200	9261	3890	8577
Dozer Blade (front)	750	1654	750	1654	750	1654	740	1632	750	1654
Dozer Blade (rear)	650	1433	650	1433	650	1433	770	1698	650	1433
Outriggers (front)	960	2117	960	2117	960	2117	1030	2271	960	2117
Outriggers (rear)	950	2095	950	2095	950	2095	1010	2227	950	2095

*Boom weight includes boom, boom lines, boom cylinders, boom cylinder rod end pin, stick cylinder, stick cylinder head end pin and boom nose pin.

**Stick weight includes stick, stick lines and bucket cylinder pins.

7

	M318D		M320D2		M322D		M322D2	
	kg	lb	kg	lb	kg	lb	kg	lb
Buckets: (see data in bucket section)								
Booms:*								
One-piece Boom	1930	4256	1930	4256	2350	5182	2350	5182
Hydraulically Adjustable Boom	2230	4917	2230	4917	2830	6240	2830	6240
Sticks:**								
Short Stick	550	1213	550	1213	650	1433	650	1433
Medium Stick	580	1279	580	1279	700	1544	700	1544
Long Stick	600	1323	600	1323	780	1720	780	1720
Other:								
Upperstructure (with swing bearing, no boom)	10 050	22,160	10 050	22,160	10 245	22,590	10 245	22,590
Undercarriage (with standard tires)	4200	9261	4200	9261	4900	10,805	4900	10,805
Dozer Blade (front)	740	1632	740	1632	—	—	—	—
Dozer Blade (rear)	770	1698	770	1698	920	2029	920	2029
Outriggers (front)	1030	2271	1030	2271	1260	2778	1260	2778
Outriggers (rear)	1010	2227	1010	2227	1220	2690	1220	2690

*Boom weight includes boom, boom lines, boom cylinders, boom cylinder rod end pin, stick cylinder, stick cylinder head end pin and boom nose pin.

**Stick weight includes stick, stick lines and bucket cylinder pins.

	M314F		M316F		M318F		M320F		M322F	
	kg	lb	kg	lb	kg	lb	kg	lb	kg	lb
Buckets: (see data in bucket section)										
Booms:*										
One-piece Boom	1250	2756	1530	3374	1560	3440	1930	4256	2350	5182
Hydraulically Adjustable Boom	1695	3737	2020	4454	2050	4520	2230	4917	2830	6240
Sticks:**										
Short Stick	370	816	470	1036	470	1036	550	1213	650	1433
Medium Stick	390	860	514	1133	514	1133	580	1279	700	1544
Long Stick	440	970	530	1169	530	1169	600	1323	780	1720
Other:										
Upperstructure (with swing bearing, no boom)	7510	16,557	8330	18,365	9565	21,087	10 315	22,740	10 045	22,145
Undercarriage (with standard tires)	3500	7718	3890	8577	4200	9261	4200	9261	4900	10,805
Dozer Blade (front)	750	1654	750	1654	740	1632	740	1632	—	
Dozer Blade (rear)	650	1433	650	1433	770	1698	770	1698	920	2029
Outriggers (front)	960	2117	960	2117	1030	2271	1030	2271	1260	2778
Outriggers (rear)	950	2095	950	2095	1010	2227	1010	2227	1220	2690

*Boom weight includes boom, boom lines, boom cylinders, boom cylinder rod end pin, stick cylinder, stick cylinder head end pin and boom nose pin.

**Stick weight includes stick, stick lines and bucket cylinder pins.

Region Offerings	320D2/320D2 L		320D2 GC	
	Africa, Middle East, Asia Pacific, China, Latin America		South America, Middle East, Africa, CIS, Asia Pacific, China	
Buckets: (see data in bucket section)	kg	lb	kg	lb
Booms:*				
One-piece Reach	2150	4750	2000	4410
One-piece Reach HD	2510	5540	—	—
Sticks:** (for Reach Boom)				
Short Stick	950	2090	—	—
Short Stick HD	1070	2360	—	—
Medium Stick	970	2140	980	2160
Medium Stick HD	1140	2510	—	—
Long Stick	1220	2690	—	—
Long Stick HD	1000	2200	—	—
Booms:*				
One-piece Mass	2180	4810	—	—
Sticks:** (for Mass Boom)				
Mass Stick	1020	2250	—	—
Upperstructure (complete w/o ctwt)	6300	14,300	5930	13,080
Undercarriage				
() Shoe Width — Standard				
(600 mm/24 in)	6660	14,680	6250	13,780
(700 mm/28 in)	7000	15,430	7040	15,520
(790 mm/31 in)	7240	15,960	—	—
() Shoe Width — Long				
(600 mm/24 in)	7190	15,850	—	—
(700 mm/28 in)	7560	16,670	—	—
(790 mm/31 in)	7830	17,260	—	—
Counterweight — Standard	3700	8160	3700	8160

*Boom weights include boom, boom lines, boom cylinders and rod end pins, stick cylinder and head end pin.

**Stick weights include stick and stick lines.

Region Offerings	320E		320E L	
	Japan		Europe	
Buckets: (see data in bucket section)	kg	lb	kg	lb
Booms:**				
Boom HD	1720	3790	1720	3790
Boom ES	2010	4430	—	—
Boom HD for CGC	1730	3810	—	—
Boom ES for CGC	2020	4450	—	—
VA Boom	—	—	2580	5690
Super Long Reach	2400	5290	2400	5290
Sticks:**				
Medium Stick HD	680	1510	680	1510
Intermediate Stick HD	—	—	—	—
Medium Stick ES	840	1850	—	—
Medium Stick HD for CGC	690	1530	—	—
Medium Stick ES for CGC	850	1870	—	—
Super Long Reach Stick	1240	2740	1240	2740
Other:				
Upperstructure (complete w/o ctwt)	11 300	24,920	11 300	24,920
Standard Undercarriage (std shoe)	6620	14,590	—	—
Long Undercarriage (std shoe)	7850	17,300	7850	17,300
Counterweight — Standard	3550	7830	3550	7830
— Super Long Reach	4600	10,140	—	—
— Heavy	5400	11,910	—	—

*Boom weights include boom, boom lines, boom cylinders and rod end pins, stick cylinder and head end pin.

**Stick weights include stick and stick lines.

Region Offerings	320E LRR		320E LRR		320F L	
	North America		Europe		North America	
Buckets: (see data in bucket section)	kg	lb	kg	lb	kg	lb
Booms:**						
Boom HD	1720	3790	1720	3790	1740	3240
Boom ES	2010	4430	—	—	—	—
Boom HD for CGC	1730	3810	—	—	—	—
Boom ES for CGC	2020	4450	—	—	—	—
VA Boom	—	—	—	—	—	—
Sticks:**						
Medium Stick HD	680	1510	680	1510	680	1500
Medium Stick ES	840	1850	—	—	—	—
Intermediate Stick ES	—	—	—	—	—	—
Medium Stick HD for CGC	690	1530	—	—	—	—
Medium Stick ES for CGC	850	1880	—	—	—	—
Other:						
Upperstructure (complete w/o ctwt)	6500	14,330	6500	14,330	7000	15,440
Long Undercarriage (std shoe)	7850	17,300	7850	17,300	7830	17,270
Counterweight — Standard	6200	13,670	6200	13,670	3700	8160
— Heavy	6900	15,210	—	—	—	—

*Boom weights include boom, boom lines, boom cylinders and rod end pins, stick cylinder and head end pin.

**Stick weights include stick and stick lines.

323D2 L

Region Offerings	Africa, Middle East, China, Latin America	
Buckets: (see data in bucket section)	kg	lb
Booms:*		
One-piece Reach HD	2410	5310
Sticks:** (for Reach Boom)		
Short Stick HD	1130	2490
Long Stick HD	1100	2430
Booms:*		
One-piece Mass	2080	4590
Sticks:** (for Mass Boom)		
Short Stick	1170	2580
Upperstructure (complete w/o ctwt)	6480	14,290
Undercarriage		
() Shoe Width – Long	7190	(600 mm/24 in) 15,850
	7570	(700 mm/28 in) 16,690
	7840	(790 mm/31 in) 17,280
Counterweight – Standard	4260	9390

*Boom weights include boom, boom lines, boom cylinders and rod end pins, stick cylinder and head end pin.

**Stick weights include stick and stick lines.

Region Offerings	323E L		323E LN		323E SA		323F L	
	Europe		Europe		Europe		North America, Europe	
Buckets: (see data in bucket section)	kg	lb	kg	lb	kg	lb	kg	lb
Booms:*								
Boom HD	1720	3790	1720	3790	1720	3792	—	—
Boom ES	2010	4430	2010	4430	2010	4431	—	—
VA Boom	2580	5690	2580	5690	2580	5688	—	—
One Piece Reach	—	—	—	—	—	—	1666	3673
One Piece Reach (CGC)	—	—	—	—	—	—	1680	3704
One Piece Reach HD	—	—	—	—	—	—	1712	3774
One Piece Reach HD (CGC)	—	—	—	—	—	—	1726	3805
One Piece Reach ES (CGC)	—	—	—	—	—	—	2016	4445
Super Long Reach	—	—	—	—	—	—	2397	5284
Sticks:**								
Small Stick HD	—	—	740	1630	—	—	—	—
Small Stick ES	—	—	—	—	740	1631	—	—
Medium Stick HD	670	1480	—	—	—	—	—	—
Medium Stick (CGC)	—	—	—	—	—	—	970	2138
Medium Stick ES	770	1700	770	1700	770	1698	—	—
Medium Stick ES (CGC)	—	—	—	—	—	—	1143	2520
Medium Stick Thumb Ready ES (CGC)	—	—	—	—	—	—	1265	2789
Intermediate Stick ES	840	1850	840	1850	840	1852	—	—
Long Stick	—	—	—	—	—	—	1228	2707
Super Long Reach	—	—	—	—	—	—	1328	2928
Other:								
Upperstructure (complete w/o ctwt)	11 300	24,910	11 450	25,240	12 240	26,985	11 220	24,736
Long Undercarriage (std shoe)	7850	17,310	6880	15,170	8340	18,387	7850	17,306
Counterweight — Standard	4100	9040	4400	9700	4400	9700	4100	9040
Counterweight — Heavy	—	—	—	—	—	—	5350	11,790
Counterweight — Super Long Reach	—	—	—	—	—	—	4700	10,360

*Boom weights include boom, boom lines, boom cylinders and rod end pins, stick cylinder and head end pin.

**Stick weights include stick and stick lines.

Region Offerings	324E/ 324E L/ 324E LN		325F L		326D2 L	
	North America, Europe, Japan		North America, Europe, Australia, New Zealand		South America, Middle East, Africa, CIS, Asia Pacific, China	
Buckets: (see data in bucket section)	kg	lb	kg	lb	kg	lb
Booms:*						
One-piece Reach VA Boom	1740	3840	1740 2783	3840 6140	2040	4500 —
Sticks:** (for Reach Boom)						
Short Stick	780	1720	—	—	1170	2580
Medium Stick	840	1850	975	2150	1220	2690
Long Stick	880	1940	—	—	—	—
Extra Long Stick	970	2140	—	—	—	—
Booms:*						
One-piece Mass	1850	4080	—	—	2150	4740
Sticks:** (for Mass Boom)						
Short Stick	970	2140	—	—	1500	3310
Upperstructure (complete w/o cwt)	—	—	7028	15,500	7220	15,920
Std	13 900	30,650	—	—	—	—
L	14 300	31,530	—	—	—	—
LN	14 500	31,970	—	—	—	—
Undercarriage () Shoe Width — Standard	(600 mm/24 in) 7717	17,013	—	—	—	—
	(700 mm/28 in) 8297	18,292	—	—	—	—
	(790 mm/31 in) 8357	18,424	—	—	—	—
Undercarriage () Shoe Width — Long	(600 mm/24 in) 8119	17,899	(790 mm/31 in) 7878	17,370	(600 mm/24 in) 8660	19,090
	(700 mm/28 in) 8699	19,178	—	—	(DG 600 mm/24 in) 8970	19,770
	(790 mm/31 in) 8759	19,310	—	—	(700 mm/28 in) 8940	19,700
	—	—	—	—	(790 mm/31 in) 9240	20,370
Counterweight — Standard	4020	8860	6800	14,990	4750	10,470
— L	6750	14,880	—	—	6780	14,950

*Boom weights include boom, boom lines, boom cylinders and rod end pins, stick cylinder and head end pin.

**Stick weights include stick and stick lines.

Region Offerings	326F		326F L		326F LN	
	Japan		Japan, North America, Europe		Europe	
Buckets: (see data in bucket section)	kg	lb	kg	lb	kg	lb
Booms:*						
One-piece Reach	1740	3836	1740	3836	1740	3836
Sticks:** (for Reach Boom)						
Short Stick	780	1720	780	1720	780	1720
Medium Stick	840	1852	840	1852	840	1852
Booms:*						
One-piece Mass	1850	4079	1850	4079	1850	4079
Sticks:** (for Mass Boom)						
Short Stick	970	2139	970	2139	970	2139
Upperstructure (complete w/o ctwt)	8930	19,690	8930	19,690	8930	19,690
Undercarriage						
() Shoe Width — Standard						
(600 mm/24 in)	7716	17,011	—	—	—	—
(700 mm/28 in)	8114	17,888	—	—	—	—
(790 mm/31 in)	8366	18,444	—	—	—	—
() Shoe Width — Long						
(600 mm/24 in)	—	—	8535	18,816	—	—
(700 mm/28 in)	—	—	8966	19,767	—	—
(790 mm/31 in)	—	—	9239	20,369	—	—
() Shoe Width — Long Narrow						
(600 mm/24 in)	—	—	—	—	8441	18,609
(700 mm/28 in)	—	—	—	—	8872	19,559
(790 mm/31 in)	—	—	—	—	9145	20,161
Counterweight — Standard	4000	8819	4000	8819	4000	8819
— Heavy	6750	14,881	6750	14,881	6750	14,881

*Boom weights include boom, boom lines, boom cylinders and rod end pins, stick cylinder and head end pin.

**Stick weights include stick and stick lines.

Region Offerings	329E/ 329E L/ 329E LN		330D2 L		330F		330F L	
	North America, Europe, Japan		South America, Middle East, Africa, CIS, Asia Pacific, China		Japan		Japan, North America, Europe	
Buckets: (see data in bucket section)	kg	lb	kg	lb	kg	lb	kg	lb
Booms:*								
One-piece Reach	—		2270	5000	—		—	
One-piece Reach HD	1950	4300	—		1950	4300	1950	4300
Sticks:** (for Reach Boom)								
Short Stick	830	1830	1270	2800	830	1830	830	1830
•	980	2160	—		—		—	
•	1000	2210	—		—		—	
•	1170	2580	—		—		—	
Medium Stick	—		1440	3170	980	2160	980	2160
Long Stick	—		—		1160	2558	1160	2558
Long HD Stick	1400	3090	—		—		—	
Booms:*								
One-piece Mass	2020	4450	2390	5270	2020	4450	2020	4450
Sticks:** (for Mass Boom)								
Short Stick	1020	2250	1550	3420	1020	2250	1020	2250
Upperstructure (complete w/o cwtw)	—		7290	16,070	9150	20,160	9150	20,160
Std	32 628	14,800	—		—		—	
L, LN	15 500	34,171	—		—		—	
Undercarriage								
() Shoe Width — Standard	(600 mm/24 in)		—		(600 mm/24 in)		—	
	8563	18,878	—		8570	18,890	—	
	(700 mm/28 in)		—		(700 mm/28 in)		—	
	8863	19,540	—		8870	19,550	—	
	(790 mm/31 in)		—		(800 mm/32 in)		—	
	9423	20,774	—		9440	20,800	—	
() Shoe Width — Long	(600 mm/24 in)		(600 mm/24 in)		—		(600 mm/24 in)	
	9243	20,377	10 210	22,510	—		9580	21,120
	(700 mm/28 in)		(HD 600 mm/24 in)		—		(700 mm/28 in)	
	9543	21,039	10 750	23,700	—		9910	21,850
	(790 mm/31 in)		(DG 600 mm/24 in)		—		(800 mm/32 in)	
	10 103	22,273	10 630	23,440	—		10 540	23,240
	—		(700 mm/28 in)		—		—	
	—		10 540	23,240	—		—	
	—		(800 mm/32 in)		—		—	
	—		11 170	24,630	—		—	
Counterweight — Standard	5810	12,810	5860	12,920	5400	11,900	5400	11,900
— Heavy	—		6750	14,880	5800	12,878	5800	12,878
— SLR	—		—		6750	14,880	6750	14,880

*Boom weights include boom, boom lines, boom cylinders and rod end pins, stick cylinder and head end pin.

**Stick weights include stick and stick lines.

Region Offerings	330F LN		335F L		336D/ 336D L	
	Europe		North America, Europe, Japan		Asia Pacific, South America	
Buckets: (see data in bucket section)	kg	lb	kg	lb	kg	lb
Booms:*						
One-piece Reach HD	1950	4300	1950	4299	3495	7706
Sticks:** (for Reach Boom)						
Short Stick	830	1830	700	1543	1890	4170
•	—	—	—	—	2012	4436
Medium Stick	980	2160	980	2161	—	—
Long Stick	1160	2558	1160	2557	—	—
Booms:*						
One-piece Mass	2020	4450	—	—	3283	7238
Sticks:** (for Mass Boom)						
Short Stick	1020	2250	970	2138	—	—
Sticks:** (for Mass Boom & VA Boom)						
Short Stick	—	—	—	—	2079	4583
Upperstructure (complete w/o ctwt)	9150	20,160	9669	21,317	8160	17,990
Undercarriage						
() Shoe Width — Standard	—	—	—	—	(600 mm/24 in)	—
	—	—	—	—	11 980	26,411
	—	—	—	—	(700 mm/28 in)	—
	—	—	—	—	12 278	27,068
	—	—	—	—	(800 mm/32 in)	—
	—	—	—	—	12 906	28,453
() Shoe Width — Long	—	—	(600 mm/24 in)	—	(600 mm/24 in)	—
	—	—	4066	8964	12 884	28,404
	—	—	(700 mm/28 in)	—	(700 mm/28 in)	—
	—	—	4391	9681	13 210	29,123
	—	—	(800 mm/32 in)	—	(800 mm/32 in)	—
	—	—	5365	11,828	13 894	30,631
() Shoe Width — Long Narrow	(600 mm/24 in)	—	—	—	—	—
	9570	21,090	—	—	—	—
	(700 mm/28 in)	—	—	—	—	—
	9900	21,830	—	—	—	—
	(800 mm/32 in)	—	—	—	—	—
	10 530	23,210	—	—	—	—
Counterweight — Standard	—	—	7700	16,976	6020	13,272
— Heavy	5800	12,878	—	—	—	—

*Boom weights include boom, boom lines, boom cylinders and rod end pins, stick cylinder and head end pin.

**Stick weights include stick and stick lines.

	336D L/ 336D LN		336D2 GC		336D2 XE 336D2 L XE	
Region Offerings	Middle East, Africa		—		—	
Buckets: (see data in bucket section)	kg	lb	kg	lb	kg	lb
Booms:*						
One-piece Reach	—	—	3900	8600	—	—
One-piece Reach HD	3255	7176	—	—	4200	9300
Sticks:** (for Reach Boom)						
Short Stick	1867	4116	1700	3700	—	—
Short Stick HD	—	—	—	—	1900	4200
Medium Stick	2012	4436	—	—	1800	4000
Medium Stick HD	—	—	—	—	2000	4400
Long Stick	2180	4807	—	—	2100	4600
Long Stick HD	2305	5083	—	—	—	—
Booms:*						
One-piece Mass	3283	7238	—	—	4000	8800
VA Boom	4433	9775	—	—	—	—
Sticks:** (for Mass Boom)						
Short Stick	2079	4583	—	—	1900	4200
Medium Stick	—	—	—	—	2000	4400
Upperstructure (complete w/o ctwt)	8160	17,990	8200	18,100	9700	21,400
Undercarriage						
() Shoe Width — Standard	—	—	(TG 600 mm/24 in)	—	(600 mm/24 in)	—
	—	—	11 760	25,800	11 900	26,300
() Shoe Width — Long	—	—	—	—	(TG 600 mm/24 in)	—
	—	—	—	—	12 400	27,400
	—	—	—	—	(TG 700 mm/28 in)	—
	—	—	—	—	12 700	28,000
Undercarriage — L	12 278	27,068	—	—	—	—
— LN	11 980	26,411	—	—	—	—
— ES	15 020	33,119	—	—	—	—
Counterweight — Standard	—	—	5200	11,500	5200	11,500
— L	6260	13,803	—	—	—	—
— LN	6260	13,803	—	—	—	—
— Heavy	—	—	—	—	5400	11,900

*Boom weights include boom, boom lines, boom cylinders and rod end pins, stick cylinder and head end pin.

**Stick weights include stick and stick lines.

Region Offerings	336E/ 336E L/ 336E LN		336E L H/ 336E LN H		336F L	
	North America, Japan, Europe		North America, Japan, Europe		North America, Japan, Europe	
Buckets: (see data in bucket section)	kg	lb	kg	lb	kg	lb
Booms:*						
One-piece Reach HD	3915	8631	3915	8631	3915	8631
Sticks:** (for Reach Boom)						
Medium Stick	1881	4147	1881	4147	1881	4147
Long HD Stick	2045	4508	2045	4508	2045	4508
Long ES Stick	2336	5150		—	2336	5150
Sticks:** (for Mass Boom)						
Medium Stick	2216	4885		—	2216	4885
Upperstructure (complete w/o ctwt)	9677	21,312	10 000	22,000	9677	21,312
Undercarriage						
() Shoe Width — Long	(600 mm/24 in)		(600 mm/24 in)		(600 mm/24 in)	
	8160	17,990	8160	17,990	8160	17,990
	(700 mm/28 in)		(700 mm/28 in)		(700 mm/28 in)	
	8812	10,428	8812	10,428	8812	10,428
	(800 mm/32 in)		(800 mm/32 in)		(800 mm/32 in)	
	10 180	22,444	10 180	22,444	10 180	22,444
Counterweight — Standard	6000	13,228	4900	10,800	6000	13,200

*Boom weights include boom, boom lines, boom cylinders and rod end pins, stick cylinder and head end pin.

**Stick weights include stick and stick lines.

Major Component Weights

● 336F ● 336F L ● 336F LN ● 336F L XE
● 336F LN XE ● 340D2 L ● 340F L

**Hydraulic
Excavators**

Region Offerings	336F/ 336F L 336F LN		336F L XE 336F LN XE		340D2 L		340F L	
	North America, Europe		North America, Europe		China, S.E. Asia, South America except Brazil, Africa, Middle East, CIS		Europe	
Buckets: (see data in bucket section)	kg	lb	kg	lb	kg	lb	kg	lb
Booms:**								
One-piece Reach	—		—		—		4400	9700
One-piece Reach HD	4100	9000	4100	9000	4200	9300		—
One-piece Reach ES	4300	9500	4300	9500	—			—
Sticks:** (for Reach Boom)								
Short Stick	—		—		1900	4200	1800	4000
Short Stick HD	1800	4000	1800	4000	2000	4400	1900	4200
Medium Stick HD	1800	4000	1800	4000	—			—
Medium Stick ES	1900	4200	1900	4200	—			—
Long Stick HD	1900	4200	1900	4200	—			—
Long Stick ES	2100	4600	2100	4600	—			—
Booms:**								
One-piece Mass	4200	9300	4200	9300	4000	8800	4400	9700
Sticks:** (for Mass Boom)								
Short Stick	—		—		1900	4200		—
Medium Stick	2100	4600	2100	4600	2000	4400	2100	4600
Upperstructure (complete w/o cwt)	9900	21,800	10 700	23,600	8200	18,100	10 000	22,000
	10 000	22,000	11 200	24,700				
Undercarriage								
() Shoe Width — Standard	(TG 700 mm/28 in)		—		—		—	
	12 100	26,700	—		—		—	
() Shoe Width — Long	(TG 600 mm/24 in)		(TG 600 mm/24 in)		(DG 600 mm/24 in)		(DG 600 mm/24 in)	
	13 600	30,000	13 600	30,000	16 200	35,700	15 700	34,600
	(TG 850 mm/33 in)		(TG 850 mm/33 in)		—		(TG 600 mm/24 in)	
	14 300	31,500	14 300	31,500	—		14 900	32,800
() Shoe Width — Long Narrow	(TG 600 mm/24 in)		(TG 600 mm/24 in)		—		—	
	13 500	29,800	13 500	29,800	—		—	
Counterweight — Standard	6000	13,200	5100	11,200	6300	13,900	7000	15,400
— Heavy	7000	15,400	6100	13,400	8500	18,700		—

*Boom weights include boom, boom lines, boom cylinders and rod end pins, stick cylinder and head end pin.

**Stick weights include stick and stick lines.

Region Offerings	349D2/ 349D2 L		349D2 L		349E/ 349E L		349F L	
	Africa, Middle East, South America, Asia Pasific, CIS		New Zealand, Australia, Turkey, Hong Kong		Japan		North America	
Buckets: (see data in bucket section)	kg	lb	kg	lb	kg	lb	kg	lb
Booms:*								
One-piece Reach	5135	11,323	5135	11,323	4630	10,200	4630	10,200
One-piece Long Reach	—		—		—		5190	11,400
Sticks:** (for Reach Boom)								
Short Stick	1670	3680	1670	3680	2400	5300	—	
Medium Stick	1690	3730	1690	3730	2540	5600	2540	5600
Long Stick	1850	3980	1850	3980	2750	6060	2750	6060
Long Reach Stick	—		—		—		2990	6600
Booms:*								
One-piece Mass	5474	12,068	5474	12,068	4860	10,700	4860	10,700
Sticks:** (for Mass Boom)								
Short Stick	1765	3890	1765	3890	2930	6460	2930	6460
Long Stick	1945	4290	1945	4290	3140	6900	3140	6900
Upperstructure (complete w/o cwtwt)								
Standard	10 800	23,810	—		24 400	53,800	—	
Long (FIX)	10 800	23,810	10 800	23,810	24 200	53,400	24 800	54,700
Long (VG)	—		—		26 800	59,100	—	
Undercarriage								
() Shoe Width — Standard	(750 mm/30 in)		—		(600 mm/24 in)		—	
	15 950	35,160	—		4940	10,900	—	
() Shoe Width — Long (FIX)	(750 mm/30 in)		(750 mm/30 in)		(750 mm/30 in)		(900 mm/35 in)	
	16 560	36,510	16 560	36,510	5890	12,990	6640	14,600
() Shoe Width — Long (VG)	—		—		(750 mm/30 in)		—	
	—		—		5940	13,100	—	
Counterweight — Standard	9000	19,800	9000	19,800	9000	19,800	9000	19,800

*Boom weights include: boom, boom lines, cylinders, rod end pins, stick cylinder and head end pin.

**Stick weights include stick, stick lines, bucket linkage and bucket cylinder.

NOTE: Heavy duty track shoes available.

Region Offerings	349F L XE		352F		352F XE	
	North America		Europe, North America		Europe	
Buckets: (see data in bucket section)	kg	lb	kg	lb	kg	lb
Booms:*						
One-piece Reach HD	4630	10,200	4630	10,200	4630	10,200
Sticks:** (for Reach Boom)						
Short Stick HD	2400	5300	2400	5300	2400	5300
Medium Stick HD	2540	5600	2540	5600	2540	5600
Long Stick HD	2760	6100	2760	6100	2760	6100
Booms:*						
One-piece Mass	4860	10,700	4860	10,700	4860	10,700
Sticks:** (for Mass Boom)						
Short Stick	3140	6900	3140	6900	3140	6900
Medium Stick	2930	6500	2930	6500	2930	6500
Upperstructure (complete w/o ctwt)	24 800	54,700	27 000	59,500	27 000	59,500
Undercarriage						
() Shoe Width — Long (FIX)	(TG 900 mm/35 in)		—		—	
	16 900	37,300	—		—	
	—		(DG 600 mm/24 in)		(DG 600 mm/24 in)	
	—		18 000	39,700	18 000	39,700
() Shoe Width — Long (VG)	—		(TG 900 mm/35 in)		(TG 750 mm/30 in)	
	—		19 400	42,800	19 400	42,800
Counterweight — Standard	8600	19,000	8600	19,000	8600	19,000
— Heavy	9000	19,800	9000	19,800	9000	19,800

*Boom weights include: boom, boom lines, cylinders, rod end pins, stick cylinder and head end pin.

**Stick weights include stick, stick lines, bucket linkage and bucket cylinder.

NOTE: Heavy duty track shoes available.

Region Offerings	374D L		374F L		390D/ 390D L		390F L	
	World Wide		World Wide		World Wide		World Wide	
Buckets: (see data in bucket section)	kg	lb	kg	lb	kg	lb	kg	lb
Booms:*								
One-piece Reach	6730	14,840	6717	14,808	9750	21,499	9839	21,691
Sticks:** (for Reach Boom)								
Short Stick	3470	7651	3487	7688	4930	10,871	4922	10,851
•	3670	8092	3674	8100	—	—	—	—
•	3790	8357	3816	8413	—	—	—	—
Long Stick	4000	8820	4025	8874	5430	11,973	5430	11,971
Booms:*								
One-piece General Purpose	—	—	—	—	8310	18,324	8392	18,501
Sticks:** (for General Purpose Boom)								
Short Stick	—	—	—	—	4910	10,827	4883	10,765
Medium Stick	—	—	—	—	—	—	5186	11,433
Long Stick	—	—	—	—	5270	11,620	4680	10,318
Booms:*								
One-piece Mass	6900	15,215	7037	15,514	8480	18,698	8437	18,600
Sticks:** (for Mass Boom)								
Short Stick	4240	9349	4019	8860	5170	11,399	5189	11,440
Long Stick	4070	8974	4228	9321	5420	11,951	5447	12,009
Upperstructure (complete w/o ctwt)	18 061	39,820	17 905	39,474	21 273	47,890	21 336	47,038
Undercarriage								
() Shoe Width — Long	(900 mm/35 in)		(900 mm/35 in)		(900 mm/35 in)		(900 mm/35 in)	
	28 036	61,810	28 218	62,210	33 105	72,980	34 924	76,994
	—	—	(750 mm/30 in)	—	—	—	(750 mm/30 in)	—
	—	—	27 205	59,977	—	—	33 877	74,686
	—	—	(650 mm/26 in)	—	—	—	(650 mm/26 in)	—
	—	—	26 530	58,489	—	—	33 003	72,759
() Shoe Width — Long (FIX)	(750 mm/30 in)		—	—	(750 mm/30 in)		—	—
	26 987	59,500	—	—	32 070	70,700	—	—
() Shoe Width — Long (VG)	(650 mm/26 in)		—	—	(650 mm/26 in)		—	—
	26 309	58,000	—	—	31 264	68,930	—	—
Counterweight — Standard	10 200	22,491	11 000	24,251	12 410	27,364	12 400	27,337
Counterweight — Removal	—	—	10 300	22,708	—	—	12 400	27,337

*Boom weights include: boom, boom lines, cylinders, rod end pins, stick cylinder and head end pin.

**Stick weights include stick and stick lines.

NOTE: Heavy duty track shoes available.

- Range Dimensions
- 300.9D
 - 301.4C
 - 301.7D
 - 301.7D CR
 - 302.2D
 - 302.4D
 - 302.7D CR

Hydraulic Excavators

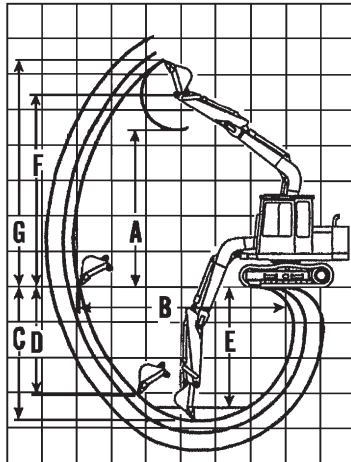

One-Piece Boom Digging Envelope

- Standard shoes and undercarriage
- Lug height not included

KEY:

- A** Maximum loading height of bucket with teeth
- B** Maximum reach at ground level
- C** Maximum digging depth
- D** Maximum vertical wall
- E** Maximum depth of cut for 2.44 m (8'0") level bottom (straight clean up)
- F** Maximum bucket hinge pin height
- G** Maximum height, to bucket teeth at highest arc

7

Stick	300.9D		301.4C		301.7D		301.7D CR		301.7D CR		301.7D CR	
	0.89 m	2'9"	1.10 m	3'6"	980 mm	3'3"	1180 mm	3'10"	940 mm	3'1"	1100 mm	3'7"
	mm	ft	mm	ft	mm	ft	mm	ft	mm	ft	mm	ft
A	2035	6'8"	2370	7'8"	2502	8'3"	2613	8'7"	2441	8'0"	2555	8'5"
B	3074	10'1"	3650	11'9"	3700	12'2"	3894	12'9"	3842	12'7"	3995	13'1"
C	1349	4'5"	2240	7'3"	2201	7'3"	2401	7'11"	2321	7'7"	2481	8'2"
D	1731	5'8"	1640	5'4"	1431	4'8"	1616	5'4"	1578	5'2"	1718	5'7"
E	—	—	—	—	—	—	—	—	—	—	—	—
F	—	—	—	—	—	—	—	—	—	—	—	—
G	2863	9'5"	3390	11'1"	3484	11'5"	3594	11'9"	3434	11'3"	3548	11'8"

Stick	302.2D		302.4D		302.4D		302.7D CR		302.7D CR		302.7D CR	
	1050 mm	3'5"	1250 mm	4'1"	1050 mm	3'5"	1250 mm	4'1"	1.05 m	3'5"	1.25 m	4'2"
	mm	ft	mm	ft	mm	ft	mm	ft	mm	ft	mm	ft
A	2720	8'11"	2810	9'2"	2747	9'0"	2870	9'5"	2840	9'3"	2970	9'7"
B	4130	13'6"	4330	14'2"	4021	13'2"	4216	13'10"	4481	14'7"	4681	15'4"
C	2490	8'2"	2690	8'10"	2402	7'11"	2602	8'6"	2544	8'3"	2744	9'0"
D	1670	5'6"	1850	6'0"	1567	5'2"	1752	5'9"	1962	6'4"	2152	7'1"
E	—	—	—	—	—	—	—	—	—	—	—	—
F	—	—	—	—	—	—	—	—	—	—	—	—
G	3840	12'6"	3930	12'10"	3949	12'11"	4071	13'4"	4170	13'7"	4300	14'1"

Hydraulic Excavators

Range Dimensions

- 303E CR ● 303.5E CR ● 303.5E2 CR ● 304E2 CR
- 305E2 CR ● 305.5E2 CR ● 307E2 ● 308E2 CR SB

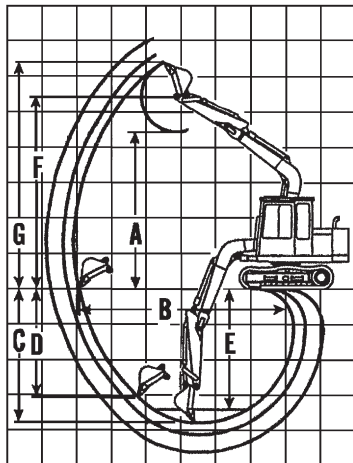

One-Piece Boom Digging Envelope

- Standard shoes and undercarriage
- Lug height not included

KEY:

- A** Maximum loading height of bucket with teeth
- B** Maximum reach at ground level
- C** Maximum digging depth
- D** Maximum vertical wall
- E** Maximum depth of cut for 2.44 m (8'0") level bottom (straight clean up)
- F** Maximum bucket hinge pin height
- G** Maximum height, to bucket teeth at highest arc

Stick	303E CR		303.5E CR		1.56 m 5'1"		303.5E2 CR		1.56 m 5'1"		304E2 CR		1.62 5'4"	
	1.26 m	4'2"	1.26 m	4'2"	mm	ft	1.26 m	4'2"	1.56 m	5'1"	1.32	4'4"	1.62	5'4"
	mm	ft	mm	ft	mm	ft	mm	ft	mm	ft	mm	ft	mm	ft
A	3150	10'4"	3520	11'6"	3640	11'11"	3520	11'6"	3640	11'11"	3590	11'9"	3690	12'1"
B	4810	15'9"	5060	16'8"	5320	17'6"	5060	16'8"	5320	17'6"	5220	17'2"	5470	18'0"
C	2750	9'0"	2880	9'6"	3180	10'4"	2880	9'6"	3180	10'4"	3130	10'3"	3430	11'3"
D	1960	6'5"	2320	7'8"	2470	8'2"	2320	7'8"	2470	8'1"	2420	7'11"	2560	8'5"
E	2220	7'3"	2380	7'10"	2720	8'11"	2380	7'10"	2720	8'11"	2650	8'8"	2980	9'9"
F	3870	12'8"	4230	13'11"	4350	14'3"	4230	13'11"	4350	14'3"	4300	14'1"	4400	14'5"
G	4530	14'10"	4920	16'2"	5030	16'6"	4920	16'2"	5030	16'6"	4980	16'4"	5070	16'8"

Stick	305E2 CR		1.75 m 5'7"		1.42 m 4'7"		1.82 m 5'10"		1.67 m 5'6"		308E2 CR SB		2.21 m 7'3"	
	1.35 m	4'4"	1.75 m	5'7"	1.42 m	4'7"	1.82 m	5'10"	1.67 m	5'6"	1.67 m	5'6"	2.21 m	7'3"
	mm	ft	mm	ft	mm	ft	mm	ft	mm	ft	m	ft	m	ft
A	3720	12'2"	3920	12'10"	3820	12'6"	4080	13'5"	5190	17'0"	4.67	15'4"	5.01	16'5"
B	5430	17'6"	5810	19'1"	5630	18'6"	6020	19'9"	6160	20'3"	6.82	22'9"	7.35	24'1"
C	3280	10'9"	3610	12'0"	3470	11'5"	3870	12'8"	4070	13'4"	4.15	13'7"	4.69	15'5"
D	2320	7'7"	2630	8'8"	2330	7'8"	2730	8'11"	3630	11'11"	2.98	9'9"	3.55	11'8"
E	2850	9'4"	3290	10'9"	3040	9'11"	3490	11'5"	3740	12'3"	3.76	12'4"	4.34	14'3"
F	4500	14'9"	4710	15'4"	4610	15'1"	4860	15'11"	6220	20'5"	5.69	18'8"	6.03	19'9"
G	5250	17'3"	5440	17'10"	5330	17'6"	5590	18'4"	7240	23'9"	6.64	21'9"	6.99	22'11"

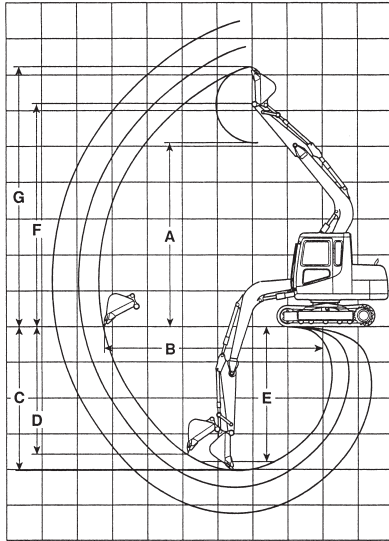

**One-Piece and VA Booms
Digging Envelope**

- Standard shoes and undercarriage
- Lug height not included

KEY:

- A** Maximum loading height of bucket with teeth
- B** Maximum reach at ground level
- C** Maximum digging depth
- D** Maximum vertical wall
- E** Maximum depth of cut for 2.44 m (8'0") level bottom (straight clean up)
- F** Maximum bucket hinge pin height
- G** Maximum height, to bucket teeth at highest arc

311F L RR Reach Boom

312D2, 312D2 L

Stick	2.25 m		2.8 m		2.5 m		3.0 m	
	m	ft	m	ft	m	ft	m	ft
A	5.44	17'1"	5.77	18'11"	6.10	20'0"	6.33	20'9"
B	7.57	24'10"	8.1	26'7"	8.18	26'10"	8.63	28'4"
C	5.04	16'6"	5.59	18'4"	5.54	18'2"	6.04	19'10"
D	4.36	14'4"	4.88	16'0"	4.64	15'3"	4.99	16'4"
E	4.33	14'2"	4.99	16'4"	5.33	17'6"	5.86	19'3"
F	—	—	—	—	—	—	—	—
G	7.82	25'8"	8.14	26'8"	8.49	27'10"	8.71	28'7"

312E Reach Boom

312E VA

Stick	2.1 m		2.5 m		2.8 m		3.0 m		2.1 m		2.5 m	
	mm	ft	mm	ft	mm	ft	mm	ft	mm	ft	mm	ft
A	5850	19'2"	6100	20'0"	6210	20'4"	6330	20'9"	6810	22'4"	7160	23'6"
B	7790	25'7"	8170	26'10"	8430	27'8"	8620	28'3"	7920	26'0"	8310	27'3"
C	5140	16'10"	5540	18'2"	5840	19'2"	6040	19'10"	4820	15'10"	5210	17'1"
D	4380	14'5"	4840	15'11"	5070	16'8"	5200	17'1"	3840	12'7"	4260	14'0"
E	4900	16'1"	5330	17'6"	5650	18'6"	5860	19'3"	4860	15'11"	5090	16'8"
F	—	—	—	—	—	—	—	—	—	—	—	—
G	8230	27'0"	8490	27'10"	8590	28'2"	8710	28'7"	9250	30'4"	9610	31'6"

Hydraulic Excavators

Range Dimensions

- 312D2 GC ● 312F GC ● 313D2 ● 313D2 LGP
- 313F L GC ● 314E CR ● 314E LCR

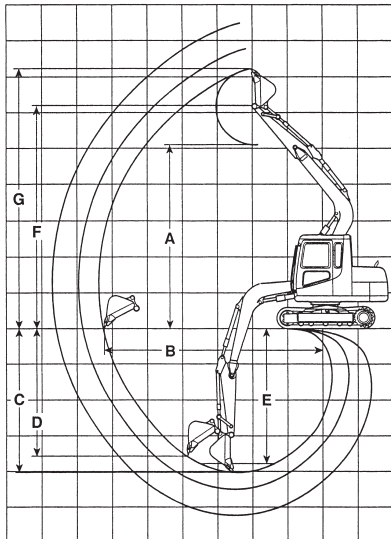

One-Piece and VA Booms Digging Envelope

- Standard shoes and undercarriage
- Lug height not included

KEY:

- A** Maximum loading height of bucket with teeth
- B** Maximum reach at ground level
- C** Maximum digging depth
- D** Maximum vertical wall
- E** Maximum depth of cut for 2.44 m (8'0") level bottom (straight clean up)
- F** Maximum bucket hinge pin height
- G** Maximum height, to bucket teeth at highest arc

Stick	312D2 GC		312F GC		313D2		313D2 LGP		313F L GC*		313F L GC*			
	2.5 m	8'2"	2.5 m	8'2"	2.5 m	8'2"	2.5 m	8'2"	3.0 m	9'10"	2.5 m	8'2"	3.0 m	9'10"
	m	ft	m	ft	m	ft	m	ft	m	ft	m	ft	m	ft
A	6.10	20'0"	6.10	20'0"	6.06	19'11"	6.45	21'2"	6.69	21'11"	6.10	20'0"	6.33	20'9"
B	8.18	26'10"	8.17	26'10"	8.21	26'11"	8.11	26'7"	8.56	28'1"	8.17	26'10"	8.62	28'3"
C	5.54	18'2"	5.54	18'2"	5.58	18'4"	5.19	17'0"	5.69	18'8"	5.54	18'2"	6.04	19'9"
D	4.91	16'1"	4.84	15'1"	5.05	16'7"	4.59	15'1"	4.96	16'3"	4.84	15'1"	5.20	17'0"
E	5.34	17'6"	5.33	17'6"	5.37	17'7"	4.98	16'4"	5.51	18'1"	5.33	17'6"	5.86	19'2"
F	—	—	—	—	—	—	—	—	—	—	—	—	—	—
G	8.49	27'10"	8.49	27'8"	8.51	27'11"	8.85	29'0"	9.07	29'9"	8.49	27'8"	8.71	28'6"

*With 4.65 m (15'3") Reach Boom.

Stick	314E CR, 314E LCR			314E LCR VA			314E CR POB, 314E LCR POB					
	2.5 m	8'2"	2.8 m	9'2"	3.0 m	9'10"	2.1 m	6'10"	2.5 m	8'2"	2.13 m	6'11"
	m	ft	m	ft	m	ft	m	ft	m	ft	m	ft
A	6.86	22'6"	7.03	23'1"	7.19	23'7"	7.01	23'0"	7.40	24'3"	6.02	19'9"
B	8.23	27'0"	8.49	27'10"	8.68	28'6"	7.98	26'2"	8.36	27'5"	7.27	23'10"
C	5.45	17'11"	5.75	18'10"	5.95	19'6"	4.81	15'9"	5.21	17'1"	4.84	15'11"
D	4.88	16'0"	5.09	16'8"	5.28	17'4"	3.92	12'10"	4.34	14'3"	3.55	11'8"
E	5.16	16'11"	5.46	17'11"	5.66	18'7"	4.68	15'4"	5.09	16'8"	4.45	14'7"
F	—	—	—	—	—	—	—	—	—	—	—	—
G	9.31	30'7"	9.48	31'1"	9.64	31'8"	9.43	30'11"	9.81	32'2"	8.45	27'9"

POB = Parallel Offset Boom

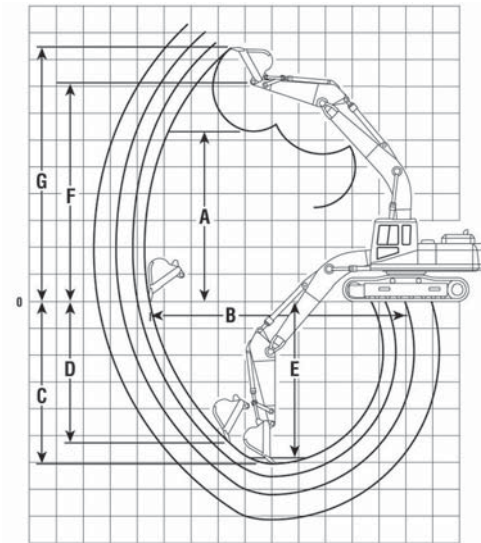

**One-Piece and VA Booms
 Digging Envelope**

- Standard shoes and undercarriage

KEY:

- A** Maximum loading height of bucket with teeth
- B** Maximum reach at ground level
- C** Maximum digging depth
- D** Maximum vertical wall
- E** Maximum depth of cut for 2.44 m (8'0") level bottom (straight clean up)
- F** Maximum bucket hinge pin height
- G** Maximum height, to bucket teeth at highest arc

316E L Reach Boom

Stick	2.25 m	7'4"	2.6 m	8'6"	2.9 m	9'6"	3.1 m	10'2"
	mm	ft	mm	ft	mm	ft	mm	ft
A	6110	20'1"	6280	20'7"	6270	20'7"	6570	21'7"
B	8460	27'9"	8780	28'10"	8990	29'6"	9260	30'5"
C	5740	18'11"	6090	20'0"	6390	21'10"	6590	21'7"
D	4490	14'8"	4930	16'2"	4910	16'1"	5400	17'9"
E	5500	18'0"	5870	19'3"	6160	20'3"	6400	21'0"
F	—	—	—	—	—	—	—	—
G	8740	28'8"	8920	29'3"	8880	29'2"	9210	30'3"

316E L VA Boom

318D2 L

Stick	2.25 m	7'6"	2.6 m	8'6"	2.9 m	8'6"	2.6 m	9'6"
	mm	ft	mm	ft	m	ft	m	ft
A	7550	24'9"	7870	25'10"	6.27	20'7"	6.28	20'7"
B	8640	28'4"	8970	29'5"	8.99	29'6"	8.78	28'10"
C	5170	17'0"	5510	18'1"	6.39	21'0"	6.09	20'0"
D	4100	13'5"	4480	14'8"	4.91	16'1"	4.93	16'3"
E	5030	16'6"	5390	17'8"	6.16	20'3"	5.87	19'3"
F	—	—	—	—	—	—	—	—
G	10 250	33'8"	10 560	34'8"	8.88	29'2"	8.92	29'3"

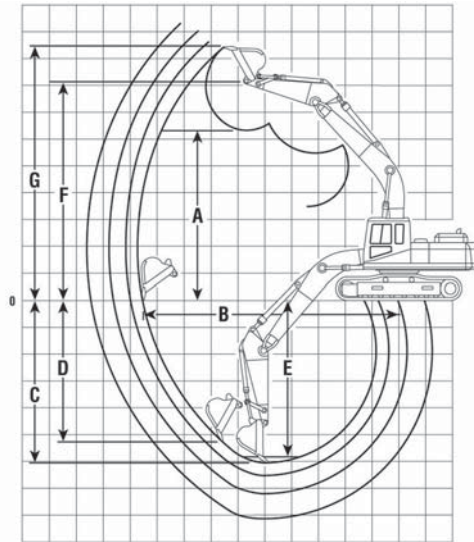

**One-Piece and VA Booms
Digging Envelope**

- Standard shoes and undercarriage

KEY:

- A** Maximum loading height of bucket with teeth
- B** Maximum reach at ground level
- C** Maximum digging depth
- D** Maximum vertical wall
- E** Maximum depth of cut for 2.44 m (8'0") level bottom (straight clean up)
- F** Maximum bucket hinge pin height
- G** Maximum height, to bucket teeth at highest arc

318E L Reach Boom

318E L VA Boom

Stick	2.25 m		2.6 m		2.9 m		3.1 m		2.25 m		2.6 m	
	mm	ft	mm	ft	mm	ft	mm	ft	mm	ft	mm	ft
A	6120	20'1"	6280	20'7"	6280	20'7"	6570	21'7"	7550	24'9"	7870	25'10"
B	8460	27'9"	8780	28'10"	8990	29'6"	9260	30'5"	8630	28'4"	8970	29'5"
C	5740	18'11"	6090	20'0"	6390	21'10"	6590	21'7"	5160	16'11"	5510	18'1"
D	4480	14'8"	4920	16'2"	4900	16'1"	5390	17'9"	4090	13'5"	4480	14'8"
E	5490	18'0"	5860	19'3"	6150	20'3"	6400	21'0"	5020	16'6"	5380	17'8"
F	—	—	—	—	—	—	—	—	—	—	—	—
G	8750	28'8"	8930	29'3"	8880	29'2"	9220	30'3"	10 260	33'8"	10 560	34'8"

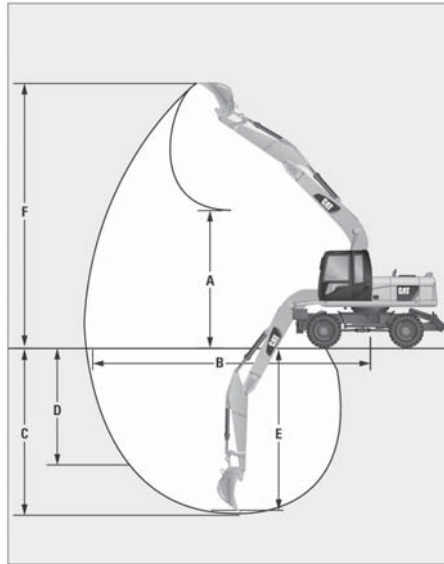

**One-Piece Boom
Digging Envelope**

- Standard dual 10.00-20 tires and undercarriage
- General purpose bucket

KEY:

- A** Maximum loading height of bucket with teeth
- B** Maximum reach at ground level
- C** Maximum digging depth
- D** Maximum vertical wall
- E** Maximum depth of cut for 2.5 m (8'2") level bottom (straight clean up)
- F** Maximum height, to bucket teeth at highest arc

M313D

M315D

Stick	2 m 6'7"		2.3 m 7'7"		2.6 m 8'6"		2.1 m 6'11"		2.4 m 7'10"		2.6 m 8'6"	
	Bucket		0.64 m ³ 0.84 yd ³		0.64 m ³ 0.84 yd ³		0.815 m ³ 1.07 yd ³		0.7 m ³ 0.92 yd ³		0.7 m ³ 0.92 yd ³	
	m	ft	m	ft	m	ft	m	ft	m	ft	m	ft
A	5.91	19'5"	5.97	19'7"	6.14	20'2"	6.00	19'8"	6.11	20'0"	6.23	20'5"
B	8.23	27'0"	8.48	27'10"	8.77	28'10"	8.71	28'7"	8.97	29'5"	9.17	30'1"
C	4.99	16'4"	5.29	17'4"	5.59	18'4"	5.39	17'8"	5.69	18'8"	5.89	19'4"
D	3.41	11'2"	3.37	11'1"	3.67	12'0"	3.51	11'6"	3.65	12'0"	3.82	12'6"
E	4.75	15'7"	5.07	16'8"	5.39	17'8"	5.17	16'11"	5.49	18'0"	5.70	18'8"
F	8.60	28'2"	8.62	28'3"	8.79	28'10"	8.98	29'5"	9.07	29'9"	9.19	30'2"

M315D2

M316D

Stick	2 m 6'7"		2.3 m 7'7"		2.6 m 8'6"		2.1 m 6'11"		2.4 m 7'10"		2.6 m 8'6"	
	Bucket		0.7 m ³ 0.92 yd ³		0.7 m ³ 0.92 yd ³		0.815 m ³ 1.07 yd ³		0.815 m ³ 1.07 yd ³		0.7 m ³ 0.92 yd ³	
	mm	ft	mm	ft	mm	ft	m	ft	m	ft	m	ft
A	6060	19'11"	6120	20'1"	6300	20'8"	6.02	19'9"	6.13	20'1"	6.25	20'6"
B	8080	26'6"	8320	27'4"	8610	28'3"	8.71	28'7"	8.97	29'5"	9.17	30'1"
C	4840	15'11"	5140	16'10"	5440	17'10"	5.37	17'7"	5.67	18'7"	5.87	19'3"
D	3750	12'4"	3740	12'3"	4040	13'3"	3.49	11'5"	3.63	11'11"	3.80	12'6"
E	4590	15'1"	4910	16'1"	5230	17'2"	5.15	16'11"	5.47	17'11"	5.68	18'8"
F	8480	27'10"	8510	27'11"	8690	28'6"	9.00	29'6"	9.09	29'10"	9.21	30'3"

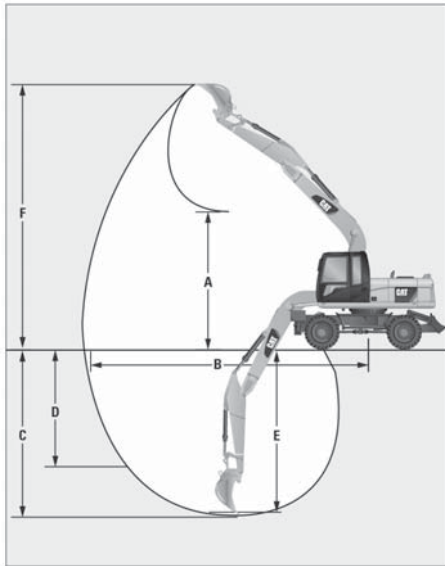

**One-Piece Boom
Digging Envelope**

- Standard dual 10.00-20 tires and undercarriage for M317D2, M318D and M320D2
- Standard dual 11.00-20 tires and undercarriage for M322D
- General purpose bucket

KEY:

- A** Maximum loading height of bucket with teeth
- B** Maximum reach at ground level
- C** Maximum digging depth
- D** Maximum vertical wall
- E** Maximum depth of cut for 2.5 m (8'2") level bottom (straight clean up)
- F** Maximum height, to bucket teeth at highest arc

M317D2

M318D

Stick	2.1 m	6'11"	2.4 m	7'10"	2.6 m	8'6"	2.2 m	7'3"	2.5 m	8'2"	2.8 m	9'2"
Bucket	0.8 m ³	1.05 yd ³	0.8 m ³	1.05 yd ³	0.8 m ³	1.05 yd ³	0.91 m ³	1.19 yd ³	0.91 m ³	1.19 yd ³	0.7 m ³	0.92 yd ³
	mm	ft	mm	ft	mm	ft	m	ft	m	ft	m	ft
A	6150	20'2"	6260	20'6"	6370	20'11"	5.90	19'4"	6.11	20'0"	6.27	20'7"
B	8560	28'1"	8830	29'0"	9020	29'7"	9.00	29'6"	9.32	30'7"	9.60	31'6"
C	5240	17'2"	5540	18'2"	5740	18'10"	5.70	18'8"	6.00	19'8"	6.30	20'8"
D	4080	13'5"	4240	13'11"	4410	14'6"	2.88	9'5"	3.34	10'11"	3.62	11'10"
E	5010	16'5"	5330	17'6"	5540	18'2"	5.49	18'0"	5.81	19'0"	6.12	20'1"
F	8880	29'2"	8970	29'5"	9090	29'10"	8.76	28'9"	9.01	29'7"	9.17	30'1"

M320D2

M322D

Stick	2.2 m	7'3"	2.5 m	8'2"	2.8 m	9'2"	2.2 m	7'3"	2.5 m	8'2"	2.9 m	9'6"
Bucket	0.9 m ³	1.18 yd ³	0.9 m ³	1.18 yd ³	0.7 m ³	0.92 yd ³	1.04 m ³	1.36 yd ³	0.805 m ³	1.05 yd ³	0.805 m ³	1.05 yd ³
	mm	ft	mm	ft	mm	ft	m	ft	m	ft	m	ft
A	6050	19'10"	6270	20'7"	6420	21'1"	6.30	20'8"	6.23	20'5"	6.45	21'2"
B	8850	29'0"	9160	30'1"	9450	31'0"	9.72	31'11"	9.93	32'7"	10.32	33'10"
C	5550	18'3"	5850	19'2"	6150	20'2"	5.77	18'11"	6.07	19'11"	6.47	21'3"
D	3660	12'0"	4120	13'6"	4420	14'6"	4.48	14'8"	4.78	15'8"	5.16	16'11"
E	5340	17'6"	5650	18'6"	5960	19'7"	5.57	18'3"	5.88	19'3"	6.30	20'8"
F	8660	28'5"	8910	29'3"	9060	29'9"	9.67	31'9"	9.54	31'3"	9.76	32'0"

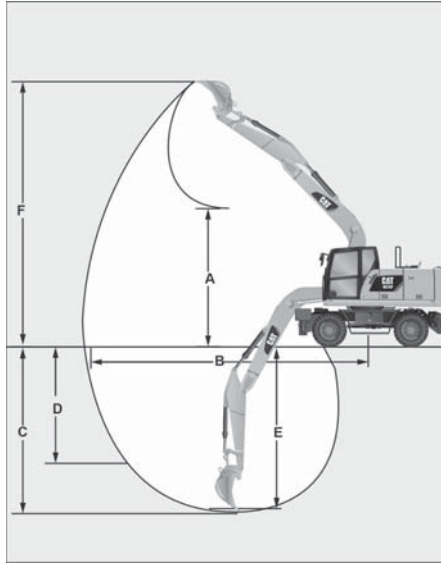

One-Piece Boom Digging Envelope

- Standard dual 10.00-20 tires and undercarriage
- General purpose bucket

KEY:

- A** Maximum loading height of bucket with teeth
- B** Maximum reach at ground level
- C** Maximum digging depth
- D** Maximum vertical wall
- E** Maximum depth of cut for 2.5 m (8'2'') level bottom (straight clean up)
- F** Maximum height, to bucket teeth at highest arc

M314F

M316F

Stick	2.0 m 6'7"		2.3 m 7'7"		2.6 m 8'6"		2.1 m 6'11"		2.4 m 7'10"		2.6 m 8'6"	
	0.68 m ³	0.89 yd ³	0.68 m ³	0.89 yd ³	0.68 m ³	0.89 yd ³	0.8 m ³	1.05 yd ³	0.8 m ³	1.05 yd ³	0.8 m ³	1.05 yd ³
Bucket	mm	ft	mm	ft	mm	ft	mm	ft	mm	ft	mm	ft
A	2800	9'2"	2485	8'2"	2185	7'2"	2760	9'1"	2450	8'0"	2250	7'5"
B	8080	26'6"	8325	27'4"	8615	28'3"	8560	28'1"	8820	28'11"	9020	29'7"
C	4840	15'11"	5140	16'10"	5440	17'10"	5240	17'2"	5540	18'2"	5740	18'10"
D	3900	12'10"	3885	12'9"	4190	13'9"	4300	14'1"	4470	14'8"	4640	15'3"
E	4590	15'1"	4900	16'1"	5230	17'2"	5010	16'5"	5330	17'6"	5540	18'2"
F	8420	27'7"	8435	27'8"	8615	28'3"	8820	28'11"	8910	29'3"	9030	29'8"

M318F

M320F

Stick	2.1 m 6'11"		2.4 m 7'10"		2.6 m 8'6"		2.5 m 8'2"		2.8 m 9'2"	
	0.8 m ³	1.05 yd ³	0.8 m ³	1.05 yd ³	0.8 m ³	1.05 yd ³	0.9 m ³	1.18 yd ³	0.7 m ³	0.92 yd ³
Bucket	mm	ft	mm	ft	mm	ft	mm	ft	mm	ft
A	6170	20'3"	6280	20'7"	6400	21'0"	6140	20'2"	6290	20'8"
B	8560	28'1"	8820	28'11"	9020	29'7"	9220	30'3"	9505	31'2"
C	5220	17'2"	5520	18'1"	5720	18'9"	5910	19'5"	6210	20'4"
D	4280	14'1"	4450	14'7"	4620	15'2"	4360	14'4"	4660	15'3"
E	4990	16'4"	5310	17'5"	5520	18'1"	5675	18'7"	5995	19'8"
F	8840	29'0"	8930	29'4"	9050	29'8"	8890	29'2"	9040	29'8"

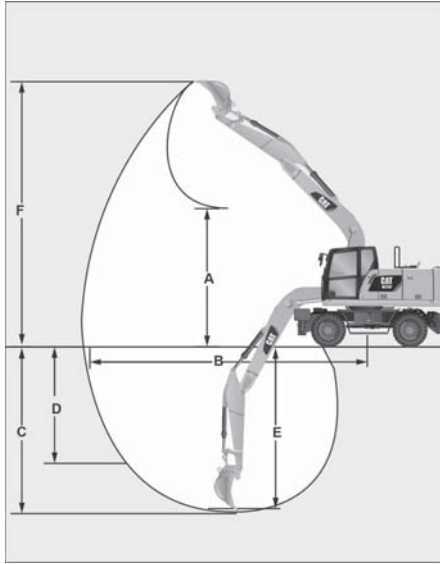

**One-Piece Boom
Digging Envelope**

- Standard dual 11.00-20 tires and undercarriage
- General purpose bucket

KEY:

-
- A** Maximum loading height of bucket with teeth
 - B** Maximum reach at ground level
 - C** Maximum digging depth
 - D** Maximum vertical wall
 - E** Maximum depth of cut for 2.5 m (8'2") level bottom (straight clean up)
 - F** Maximum height, to bucket teeth at highest arc
-

M322F

	2.2 m	7'3"	2.5 m	8'2"	2.9 m	9'6"
Stick						
Bucket	1.19 m³	1.56 yd³	1.19 m³	1.56 yd³	1.19 m³	1.56 yd³
	mm	ft	mm	ft	mm	ft
A	2810	9'3"	2520	8'3"	2120	6'11"
B	9550	31'4"	9770	32'1"	10 160	33'4"
C	5615	18'5"	5915	19'5"	6315	20'9"
D	5095	16'9"	4840	15'11"	5225	17'2"
E	5400	17'9"	5715	18'9"	6135	20'2"
F	9415	30'11"	9255	30'4"	9480	31'1"

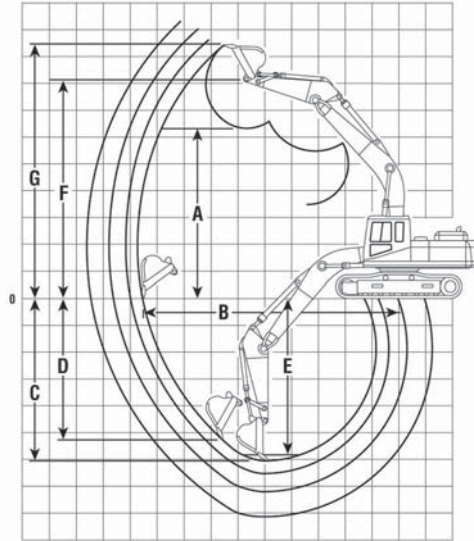

**One-Piece Boom
Digging Envelope**

- Standard shoes and undercarriage

KEY:

- A** Maximum loading height of bucket with teeth
- B** Maximum reach at ground level
- C** Maximum digging depth
- D** Maximum vertical wall
- E** Maximum depth of cut for 2.44 m (8'0") level bottom (straight clean up)
- F** Maximum bucket hinge pin height
- G** Maximum height, to bucket teeth at highest arc

Stick	320D2, 320D2 L with Reach Boom				320D2, 320D2 L with Mass Boom		320D2 GC with Reach Boom	
	2.5 m	8'2"	2.9 m	9'6"	2.4 m	7'10"	2.9 m	9'6"
	m	ft	m	ft	m	ft	m	ft
A	6.36	20'10"	6.56	21'6"	5.84	19'2"	6.57	21'7"
B	9.40	30'1"	9.79	32'1"	8.85	29'0"	9.78	32'1"
C	6.24	20'6"	6.66	21'1"	5.77	18'11"	6.64	21'9"
D	5.60	18'4"	6.01	19'7"	4.89	16'1"	6.01	19'9"
E	6.04	19'1"	6.48	21'3"	5.39	17'8"	6.47	21'3"
F	7.87	25'9"	8.06	26'5"	7.43	24'5"	—	—
G	9.24	30'4"	9.45	31'0"	8.78	28'10"	9.44	31'0"

**320E L, 320E LN, 320E LRR
with Reach Boom**

Stick	3.9 m		2.9 m		2.5 m		1.9 m	
	mm	ft	mm	ft	mm	ft	mm	ft
A	7030	23'0"	6490	21'4"	6300	20'8"	5930	19'5"
B	10 680	35'0"	9860	30'9"	9450	31'0"	8950	29'4"
C	7580	24'10"	6720	22'1"	6290	20'8"	5760	18'11"
D	6910	22'7"	5060	16'7"	5210	17'1"	4360	14'4"
E	7440	24'4"	6550	21'6"	6100	20'0"	5520	18'1"
F	—	—	—	—	—	—	—	—
G	9890	32'4"	9370	30'7"	9240	30'4"	8940	29'4"

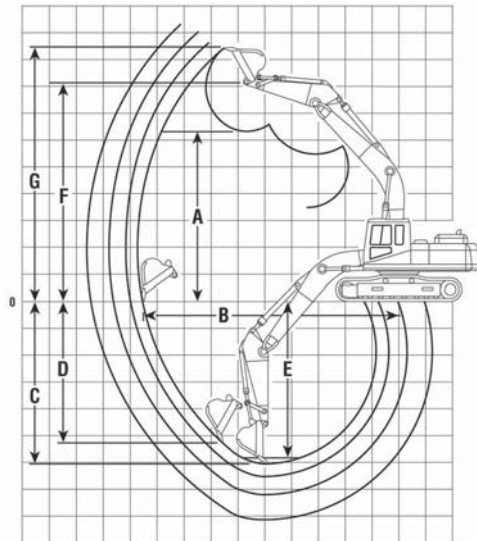

**One-Piece and VA Booms
Digging Envelope**

- Standard shoes and undercarriage

KEY:

- A** Maximum loading height of bucket with teeth
- B** Maximum reach at ground level
- C** Maximum digging depth
- D** Maximum vertical wall
- E** Maximum depth of cut for 2.44 m (8'0") level bottom (straight clean up)
- F** Maximum bucket hinge pin height
- G** Maximum height, to bucket teeth at highest arc

Stick	320E L, 320E LRR with VA Boom				320E L, 320E LRR with Super Long Reach		320F L with Reach Boom	
	2.9 m mm	9'6" ft	2.5 m mm	7'6" ft	6.28 m mm	20'6" ft	2.9 m m	9'6" ft
A	8410	27'7"	8070	26'6"	11 290	37'0"	6.49	21'4"
B	10 200	33'6"	9800	32'2"	15 720	51'6"	9.86	32'4"
C	6680	21'11"	6270	20'7"	11 690	38'4"	6.72	22'1"
D	5290	17'4"	4890	16'1"	10 670	35'0"	5.06	16'7"
E	6580	21'7"	6170	20'3"	11 590	38'0"	6.55	21'6"
F	—	—	—	—	—	—	—	—
G	11 520	37'10"	11 180	36'8"	13 590	44'6"	9.37	30'9"

Stick	323D2 L with Reach Boom				323D2 L with Mass Boom			
	1.9 m m	6'3" ft	2.5 m m	8'2" ft	2.92 m m	9'7" ft	1.9 m m	6'3" ft
A	5.99	19'8"	6.59	21'7"	6.77	22'2"	5.53	18'2"
B	8.98	29'5"	9.44	31'0"	9.86	32'4"	8.46	27'9"
C	5.78	19'0"	6.20	20'4"	6.65	21'10"	5.35	17'7"
D	3.74	12'3"	5.09	16'8"	5.52	18'1"	3.88	12'9"
E	5.51	18'1"	5.99	19'8"	6.47	21'3"	5.00	16'5"
F	—	—	—	—	—	—	—	—
G	8.94	29'4"	9.38	30'9"	9.58	31'5"	8.56	28'1"

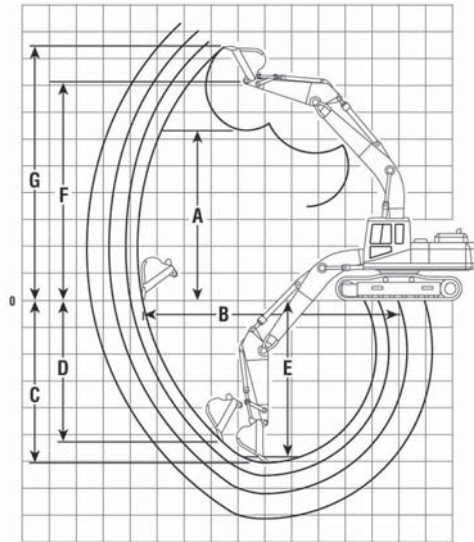

One-Piece and VA Booms Digging Envelope

- Standard shoes and undercarriage

KEY:

- A** Maximum loading height of bucket with teeth
- B** Maximum reach at ground level
- C** Maximum digging depth
- D** Maximum vertical wall
- E** Maximum depth of cut for 2.44 m (8'0") level bottom (straight clean up)
- F** Maximum bucket hinge pin height
- G** Maximum height, to bucket teeth at highest arc

323D2 L with Reach Boom

323D2 L with Mass Boom

Stick	2.5 m		8'2"		2.9 m		9'6"		2.4 m		7'10"	
	m	ft	m	ft	m	ft	m	ft	m	ft		
A	6.29	20'8"	6.49	21'4"	5.76	18'11"						
B	9.63	31'7"	9.86	32'4"	8.92	29'3"						
C	6.30	20'8"	6.72	22'1"	5.85	19'2"						
D	5.65	18'6"	5.69	18'8"	4.58	15'0"						
E	5.96	19'7"	6.38	20'11"	5.5	18'1"						
F	—	—	—	—	—	—						
G	9.29	30'6"	9.49	31'0"	8.83	29'3"						

323D2 L with VA Boom

323D2 L with Reach Boom

Stick	1.9 m		6'3"		2.5 m		8'2"		2.9 m		9'6"		1.9 m		6'3"		2.5 m		8'2"		2.9 m		9'6"	
	m	ft	m	ft	m	ft	m	ft	m	ft	m	ft	m	ft	m	ft	m	ft	m	ft	m	ft		
A	7.51	24'8"	8.09	26'6"	8.43	27'8"	5.97	19'7"	6.57	21'7"	6.74	22'1"												
B	9.28	30'5"	9.79	32'1"	10.20	33'5"	8.84	29'0"	9.28	30'5"	9.70	31'10"												
C	5.74	18'10"	6.27	20'7"	6.68	21'11"	5.61	18'5"	6.03	19'9"	6.48	21'3"												
D	3.46	11'4"	4.10	13'5"	4.52	14'10"	3.60	11'10"	4.94	16'2"	5.38	17'8"												
E	5.63	18'6"	6.16	20'2"	6.58	21'7"	5.35	17'7"	5.83	19'2"	6.29	20'8"												
F	—	—	—	—	—	—	—	—	—	—	—													
G	10.74	35'3"	11.17	36'8"	11.51	37'9"	8.88	29'2"	9.31	30'7"	9.51	31'2"												

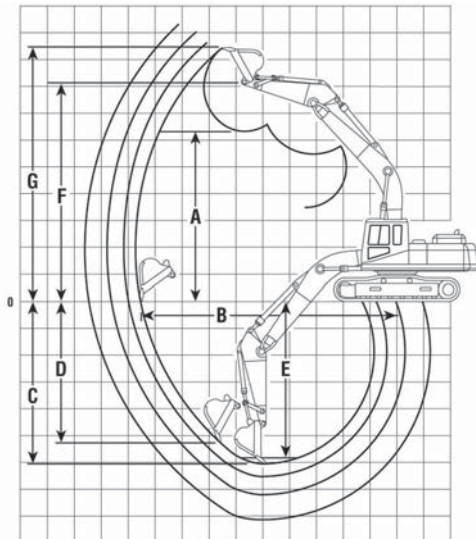

**One-Piece and VA Booms
Digging Envelope**

- Standard shoes and undercarriage

KEY:

- A** Maximum loading height of bucket with teeth
- B** Maximum reach at ground level
- C** Maximum digging depth
- D** Maximum vertical wall
- E** Maximum depth of cut for 2.44 m (8'0") level bottom (straight clean up)
- F** Maximum bucket hinge pin height
- G** Maximum height, to bucket teeth at highest arc

**323E SA
with Reach Boom**

**323E SA
with VA Boom**

Stick	2.9 m		9'6"		2.5 m		8'2"		1.9 m		6'3"		2.5 m		8'2"	
	mm	ft	mm	ft	mm	ft	mm	ft	mm	ft	mm	ft	mm	ft	mm	ft
A	6580	21'7"	6370	20'11"	6000	19'8"	8140	26'8"								
B	9840	32'3"	9440	31'0"	8930	29'4"	9780	32'1"								
C	6640	21'9"	6220	20'5"	5680	18'8"	6200	20'4"								
D	5540	18'4"	5140	16'10"	4350	14'3"	4820	15'10"								
E	6470	21'3"	6030	19'9"	5450	17'11"	6100	20'0"								
F	—	—	—	—	—	—	—	—								
G	9520	31'3"	9320	30'7"	9010	29'7"	11 250	36'11"								

323E L, 323E LN

**323E
with VA Boom**

Stick	3.9 m		12'6"		2.9 m		9'6"		2.5 m		8'2"		1.9 m		6'3"		2.9 m		9'6"		2.5 m		7'6"		
	mm	ft	mm	ft	mm	ft	mm	ft	mm	ft	mm	ft	mm	ft	mm	ft	mm	ft	mm	ft	mm	ft	mm	ft	
A	7020	23'0"	6490	21'4"	6300	20'8"	5930	19'6"	8410	27'7"	8070	26'6"													
B	10 680	35'0"	9860	30'9"	9450	31'0"	8950	29'4"	10 200	33'6"	9800	32'2"													
C	7580	24'10"	6720	22'1"	6290	20'8"	5760	18'11"	6680	21'11"	6270	20'7"													
D	6960	22'10"	5060	16'7"	5210	17'1"	4360	14'4"	5290	17'4"	4890	16'1"													
E	7230	23'9"	6550	21'6"	6100	20'0"	5520	18'1"	6580	21'7"	6170	20'3"													
F	—	—	—	—	—	—	—	—	—	—	—	—													
G	9870	32'5"	9370	30'7"	9240	30'4"	8940	29'4"	11 520	37'10"	11 180	36'8"													

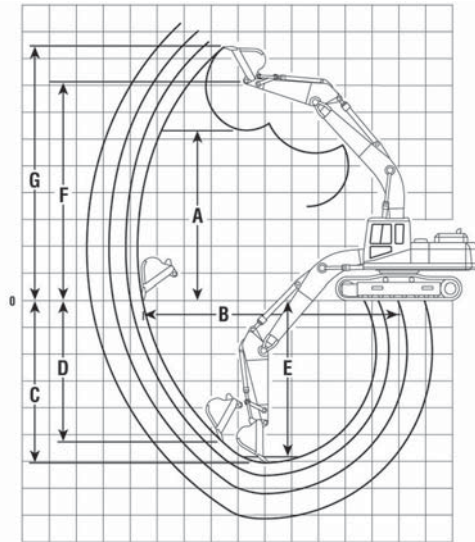

**One-Piece and VA Booms
 Digging Envelope**

- Standard shoes and undercarriage

KEY:

- A** Maximum loading height of bucket with teeth
- B** Maximum reach at ground level
- C** Maximum digging depth
- D** Maximum vertical wall
- E** Maximum depth of cut for 2.44 m (8'0") level bottom (straight clean up)
- F** Maximum bucket hinge pin height
- G** Maximum height, to bucket teeth at highest arc

**323F L
 with Reach Boom**

Stick	3.9 m	12'6"	2.9 m	9'6"	2.5 m	7'6"	1.9 m	6'3"
	mm	ft	mm	ft	mm	ft	mm	ft
A	7030	23'1"	6490	21'4"	6300	20'8"	5930	19'5"
B	10 680	35'0"	9860	32'4"	9450	31'0"	8950	29'4"
C	7580	24'10"	6720	22'1"	6290	20'8"	5760	18'11"
D	6910	22'8"	5060	16'7"	5210	17'1"	4360	14'4"
E	7440	24'5"	6550	21'6"	6100	20'0"	5520	18'1"
F	—	—	—	—	—	—	—	—
G	9890	32'5"	9370	30'9"	9240	30'4"	8940	29'4"

**323F L
 with VA Boom**

**323F L, 323F LN, 323F LRR
 with Super Long Reach**

Stick	2.9 m	9'6"	2.5 m	7'6"	6.28 m	20'6"
	mm	ft	mm	ft	mm	ft
A	8410	27'7"	8070	26'6"	11 290	37'0"
B	10 200	33'6"	9800	32'2"	15 720	51'7"
C	6680	21'11"	6270	20'7"	11 690	38'4"
D	5290	17'4"	4890	16'1"	10 670	35'0"
E	6580	21'7"	6170	20'3"	11 280	37'0"
F	—	—	—	—	—	—
G	11 520	37'10"	11 180	36'8"	13 590	44'7"

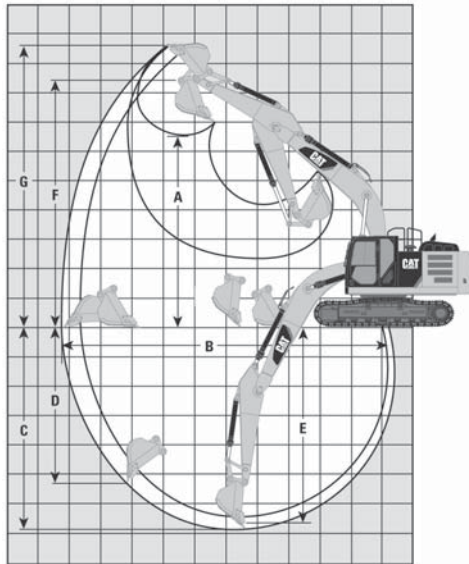

**One-Piece and VA Booms
Digging Envelope**

- Standard shoes and undercarriage

KEY:

- A** Maximum loading height of bucket with teeth
- B** Maximum reach at ground level
- C** Maximum digging depth
- D** Maximum vertical wall
- E** Maximum depth of cut for 2.44 m (8'0") level bottom (straight clean up)
- F** Maximum bucket hinge pin height
- G** Maximum height, to bucket teeth at highest arc

Stick	324E L, 324E LN with 5.9 m (19'4") Reach Boom				324E L, 324E LN with 5.3 m (17'5") Mass Boom		324E L, 324E LN with 5.6 m (18'4") VA Boom			
	2.5 m m	8'2" ft	2.95 m m	9'8" ft	2.5 m m	8'2" ft	2.5 m m	8'2" ft	2.95 m m	9'8" ft
A	6.44	21'2"	7.45	24'5"	5.89	19'4"	—	—	8.32	27'4"
B	9.69	31'9"	10.11	33'2"	9.20	30'2"	—	—	10.33	33'11"
C	6.36	20'10"	6.81	22'4"	6.00	19'8"	—	—	6.69	21'11"
D	4.87	16'0"	5.30	17'5"	4.25	13'11"	—	—	5.10	16'9"
E	6.16	20'3"	6.64	21'9"	5.81	19'1"	—	—	6.59	21'7"
F	—	—	—	—	—	—	—	—	9.97	32'9"
G	9.49	31'2"	9.69	31'9"	9.06	29'9"	—	—	11.60	38'1"

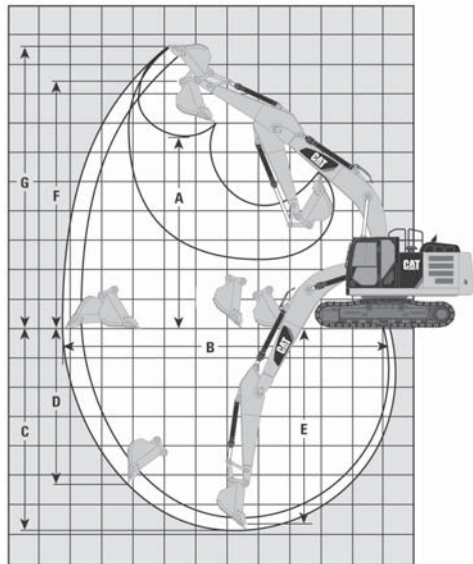

**One-Piece and VA Booms
Digging Envelope**

- Standard shoes and undercarriage

KEY:

- A** Maximum loading height of bucket with teeth
- B** Maximum reach at ground level
- C** Maximum digging depth
- D** Maximum vertical wall
- E** Maximum depth of cut for 2.44 m (8'0") level bottom (straight clean up)
- F** Maximum bucket hinge pin height
- G** Maximum height, to bucket teeth at highest arc

**325F L
with 5.7 m (18'8")
Reach Boom**

**325F L with VA Boom
[2.8 m (9'2") Stub +
3.3 m (10'10") Fore]**

**326D2 L
with Reach Boom**

Stick	2.9 m		9'6"		2.9 m		9'6"		2.5 m		8'2"		2.95 m		9'8"	
	m	ft	m	ft	m	ft	m	ft	m	ft	m	ft	m	ft	m	ft
A	7.89	25'11"	8.54	28'0"	6.39	21'0"	6.59	21'7"								
B	9.79	32'1"	10.13	33'3"	9.74	31'11"	10.15	33'4"								
C	6.71	22'0"	6.51	21'4"	6.40	21'0"	6.85	22'6"								
D	5.00	16'5"	5.17	17'0"	4.98	16'4"	5.41	17'9"								
E	6.54	21'5"	6.42	21'1"	6.20	20'4"	6.67	21'11"								
F	—	—	—	—	—	—	—	—								
G	10.96	35'11"	11.65	38'3"	9.50	32'2"	9.70	31'1"								

**326F L, 326F LN
with 5.9 m (19'4") Reach Boom**

**326F L, 326F LN
with 5.6 m (18'4") VA Boom**

Stick	2.5 m		8'2"		2.95 m		9'8"		2.95 m		9'8"	
	m	ft	m	ft	m	ft	m	ft	m	ft	m	ft
A	6.44	21'2"	7.45	24'5"	8.32	27'4"						
B	9.69	31'9"	10.11	33'2"	10.34	33'11"						
C	6.36	20'10"	6.81	22'4"	6.69	21'11"						
D	4.87	16'0"	5.30	17'5"	5.10	16'9"						
E	6.16	20'3"	6.64	21'9"	6.59	21'7"						
F	9.617	31'7"	9.956	32'8"	9.97	32'9"						
G	9.49	31'2"	9.69	31'9"	11.60	38'1"						

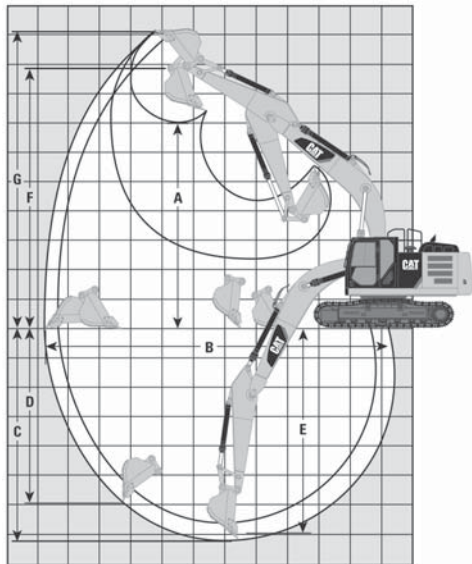

**One-Piece Boom
Digging Envelope**

- Standard shoes and undercarriage

KEY:

- A** Maximum loading height of bucket with teeth
- B** Maximum reach at ground level
- C** Maximum digging depth
- D** Maximum vertical wall
- E** Maximum depth of cut for 2.44 m (8'0") level bottom (straight clean up)
- F** Maximum bucket hinge pin height
- G** Maximum height, to bucket teeth at highest arc

**329E L, 329E LN
with 6.15 m (20'2")
Reach Boom**

**329E L, 329E LN
with 5.55 m (18'3")
Mass Boom**

Stick	2.7 m	8'8"	3.2 m	10'6"	2.5 m	8'2"
	m	ft	m	ft	m	ft
A	6.80	22'4"	6.95	22'10"	6.00	19'8"
B	10.20	33'6"	10.68	35'0"	9.43	30'11"
C	6.70	22'0"	7.25	23'9"	6.10	20'0"
D	5.68	18'8"	5.98	19'7"	4.25	13'11"
E	6.52	21'5"	7.09	23'3"	5.91	19'5"
F	8.45	27'9"	8.60	28'3"	7.65	25'1"
G	9.90	32'6"	10.01	32'10"	9.13	30'11"

**330F, 330F L, 330F LN
with 6.15 m (20'2")
Reach Boom**

**335F L
with 6.15 m (20'3")
Reach Boom**

Stick	2.65 m	8'8"	3.2 m	10'6"	3.75 m	12'4"	2.65 m	8'8"	3.2 m	10'6"
	mm	ft	mm	ft	mm	ft	m	ft	m	ft
A	6800	22'4"	6950	22'10"	7140	23'4"	7.75	25'5"	7.97	26'2"
B	10 200	33'6"	10 680	35'0"	11 180	36'7"	10.16	33'4"	10.64	34'11"
C	6700	22'0"	7250	23'9"	7800	25'6"	6.44	21'2"	6.99	22'11"
D	5680	18'8"	5980	19'7"	6420	21'1"	5.46	17'11"	5.77	18'11"
E	6520	21'5"	7090	23'3"	7660	25'1"	6.26	20'6"	6.83	22'5"
F	8450	27'9"	8600	28'3"	8790	28'10"	—	—	—	—
G	9900	32'6"	10 010	32'10"	10 190	33'4"	10.95	35'11"	11.15	36'7"

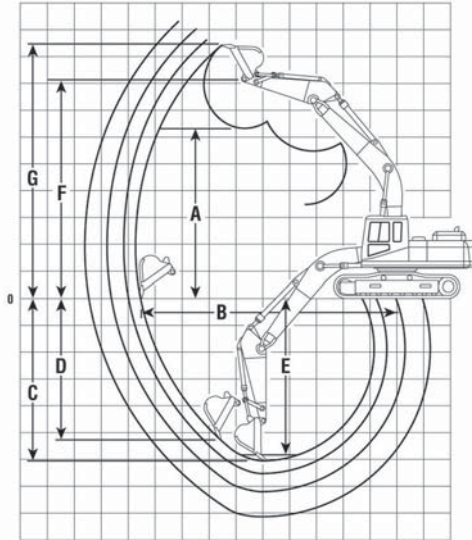

**One-Piece Boom
Digging Envelope**

- Standard shoes and undercarriage

KEY:

- A** Maximum loading height of bucket with teeth
- B** Maximum reach at ground level
- C** Maximum digging depth
- D** Maximum vertical wall
- E** Maximum depth of cut for 2.44 m (8'0") level bottom (straight clean up)
- F** Maximum bucket hinge pin height
- G** Maximum height, to bucket teeth at highest arc

**336D, 336D L
with Reach Boom**

**336D, 336D L
with Mass Boom**

Stick	2.15 m		3.2 m		3.9 m		2.15 m		2.55 m	
	m	ft	m	ft	m	ft	m	ft	m	ft
A	6.53	21'5"	7.20	23'7"	7.64	25'1"	6.41	21'0"	6.69	21'11"
B	10.07	33'0"	10.92	35'10"	11.64	38'2"	9.76	32'0"	10.18	33'5"
C	6.50	21'4"	7.39	24'3"	8.09	26'7"	6.17	20'3"	6.57	21'7"
D	4.80	15'9"	5.83	19'2"	6.70	13'0"	4.71	15'5"	5.34	17'6"
E	6.28	20'7"	7.23	23'9"	7.96	26'1"	5.97	19'7"	6.40	21'0"
F	8.35	27'5"	—	—	—	—	8.23	27'0"	—	—
G	9.82	32'3"	10.71	33'7"	10.71	35'22"	9.74	31'11"	10.07	33'0"

**336D2 GC with
Reach Boom**

**336D2 XE, 336D2 L XE
with Reach Boom**

**336D2 XE, 336D2 L XE
with Mass Boom**

Stick	2.8 m		2.8 m		3.2 m		3.9 m		2.15 m		2.55 m	
	m	ft	m	ft	m	ft	m	ft	m	ft	m	ft
A	7.08	23'3"	7.08	23'3"	7.08	23'3"	7.51	24'8"	6.31	20'8"	6.60	21'8"
B	10.75	35'3"	10.75	35'3"	11.05	36'3"	11.76	38'7"	9.85	32'4"	10.28	33'9"
C	7.11	23'4"	7.11	23'4"	7.51	24'8"	8.21	26'1"	6.27	20'7"	6.67	21'1"
D	5.40	17'9"	5.40	17'9"	5.42	17'9"	6.29	20'8"	4.06	13'4"	4.70	15'5"
E	6.95	22'1"	6.95	22'1"	7.36	24'2"	8.08	26'6"	6.06	19'1"	6.49	21'4"
F	—	—	—	—	—	—	—	—	—	—	—	—
G	10.32	33'1"	10.32	33'1"	10.25	33'8"	10.73	35'2"	9.64	31'8"	9.99	32'9"

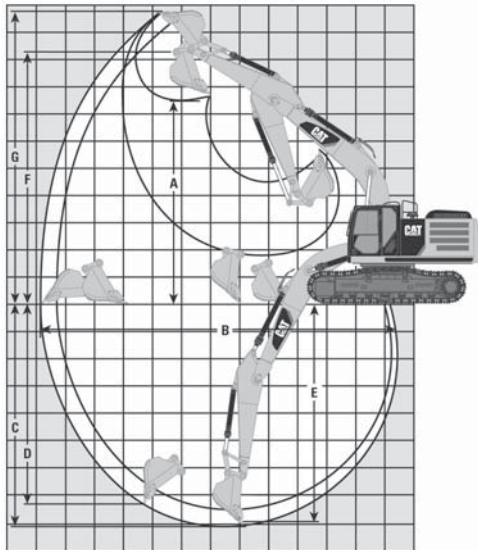

**One-Piece Boom
Digging Envelope**

- Standard shoes and undercarriage

KEY:

- A** Maximum loading height of bucket with teeth
- B** Maximum reach at ground level
- C** Maximum digging depth
- D** Maximum vertical wall
- E** Maximum depth of cut for 2.44 m (8'0") level bottom (straight clean up)
- F** Maximum bucket hinge pin height
- G** Maximum height, to bucket teeth at highest arc

**336E L, 336E LN, 336E L H, 336E LN H
with Reach Boom**

**336E L, 336E LN
with Mass Boom**

Stick	2.8 m		3.2 m		3.9 m		2.15 m		2.55 m	
	m	ft	m	ft	m	ft	m	ft	m	ft
A	7.11	23'4"	7.11	23'4"	7.50	24'7"	6.34	20'10"	6.62	21'9"
B	10.71	35'2"	11.02	36'2"	11.72	38'5"	9.83	32'3"	10.26	33'8"
C	7.09	23'3"	7.49	24'7"	8.19	26'10"	6.25	20'6"	6.65	21'10"
D	5.47	17'11"	5.50	18'1"	6.31	20'8"	3.81	13'6"	4.45	14'7"
E	6.39	21'0"	6.82	22'5"	7.61	25'0"	5.28	17'4"	5.81	19'1"
F	8.89	29'2"	8.90	29'2"	9.29	30'5"	8.26	27'1"	8.54	28'1"
G	10.37	34'0"	10.32	33'10"	10.74	35'3"	9.63	31'7"	9.97	32'9"

**336F L
with Reach Boom**

**336F L
with Mass Boom**

Stick	2.8 m		3.2 m		3.9 m		2.15 m		2.55 m	
	m	ft	m	ft	m	ft	m	ft	m	ft
A	7.11	23'4"	7.11	23'4"	7.50	24'7"	6.34	20'10"	6.62	21'9"
B	10.71	35'2"	11.02	36'2"	11.70	38'5"	9.83	32'3"	10.26	33'8"
C	7.09	23'3"	7.49	24'7"	8.19	26'10"	6.25	20'6"	6.65	21'10"
D	5.47	17'11"	5.50	18'1"	6.31	20'8"	3.81	13'6"	4.45	14'7"
E	6.39	21'0"	6.82	22'5"	7.61	25'0"	5.28	17'4"	5.81	19'1"
F	8.89	29'2"	8.90	29'2"	9.29	30'5"	8.26	27'1"	8.54	28'1"
G	10.37	34'0"	10.32	33'10"	10.74	35'3"	9.63	31'7"	9.97	32'9"

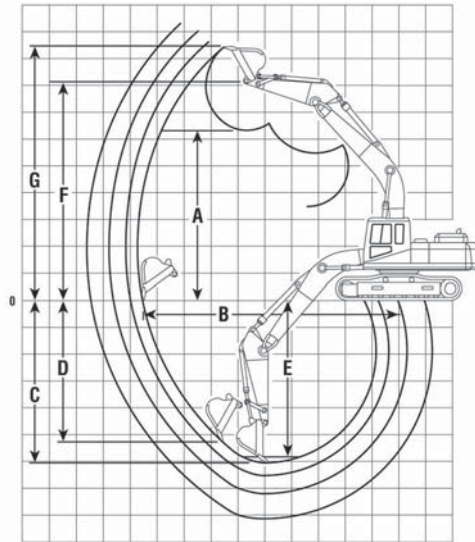

**One-Piece Boom
Digging Envelope**

- Standard shoes and undercarriage

KEY:

- A** Maximum loading height of bucket with teeth
- B** Maximum reach at ground level
- C** Maximum digging depth
- D** Maximum vertical wall
- E** Maximum depth of cut for 2.44 m (8'0") level bottom (straight clean up)
- F** Maximum bucket hinge pin height
- G** Maximum height, to bucket teeth at highest arc

Stick	340D2 L with Reach Boom		340D2 L with Mass Boom		340F L with Reach Boom		340D2 L with Reach Boom		340D2 L with Mass Boom		340F L with Reach Boom	
	2.8 m	9'2"	3.2 m	10'6"	2.15 m	7'1"	2.55 m	8'4"	2.8 m	9'2"	3.2 m	10'6"
	m	ft	m	ft	m	ft	m	ft	m	ft	m	ft
A	7.00	23'0"	7.00	23'0"	6.27	20'7"	6.55	21'6"	7.34	24'1"	7.34	24'1"
B	10.83	35'6"	11.13	36'6"	9.89	32'5"	10.32	33'1"	10.67	35'0"	10.97	36'0"
C	7.19	23'7"	7.59	24'1"	6.31	20'8"	6.71	22'0"	6.86	22'6"	7.26	23'1"
D	5.46	17'1"	5.48	18'0"	4.06	13'4"	4.70	15'5"	5.24	17'2"	5.27	17'3"
E	6.37	20'1"	6.79	22'3"	5.27	17'3"	5.80	19'0"	6.16	20'3"	6.59	21'7"
F	—	—	—	—	—	—	—	—	—	—	—	—
G	10.33	33'1"	10.25	33'8"	9.63	31'7"	9.98	32'9"	10.60	34'9"	10.55	34'7"

Stick	340F L with Mass Boom		349D2 L – FIX with Reach Boom		349D2 L – FIX with Mass Boom		340F L with Mass Boom		349D2 L – FIX with Mass Boom	
	2.8 m	9'2"	3.35 m	11'0"	3.9 m	12'10"	2.5 m	8'2"	3 m	9'10"
	m	ft	m	ft	m	ft	m	ft	m	ft
A	6.85	22'6"	7.47	24'6"	7.45	24'5"	6.62	21'9"	6.81	22'4"
B	10.21	33'6"	11.66	38'3"	12.08	39'8"	10.71	35'2"	11.18	36'8"
C	6.42	21'1"	7.60	24'11"	8.15	26'9"	6.72	22'1"	7.22	23'8"
D	4.22	13'1"	6.30	20'8"	6.46	21'2"	4.92	16'2"	5.38	17'8"
E	5.58	18'4"	7.46	24'6"	8.02	26'4"	6.55	21'6"	7.07	23'2"
F	—	—	9.29	30'6"	9.28	30'5"	8.64	28'4"	8.83	29'0"
G	10.20	33'6"	10.80	35'5"	10.71	35'2"	10.23	33'7"	10.42	34'2"

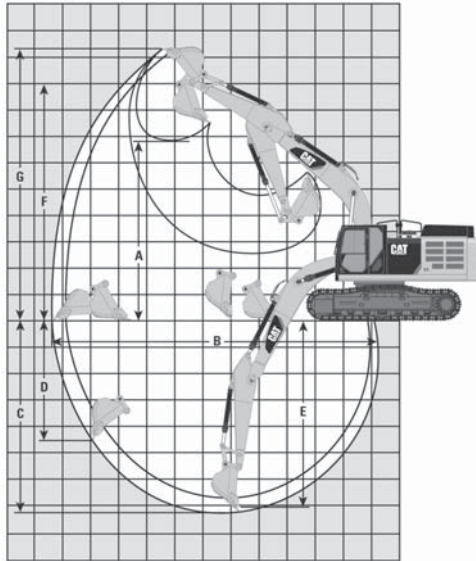

**One-Piece and VG Booms
Digging Envelope**

- Standard shoes and undercarriage

KEY:

- A** Maximum loading height of bucket with teeth
- B** Maximum reach at ground level
- C** Maximum digging depth
- D** Maximum vertical wall
- E** Maximum depth of cut for 2.44 m (8'0") level bottom (straight clean up)
- F** Maximum bucket hinge pin height
- G** Maximum height, to bucket teeth at highest arc

**349E L – FIX
with Reach Boom**

**349E L – FIX
with Mass Boom**

Stick	3.35 m	11'0"	3.9 m	12'10"	2.5 m	8'2"	3 m	9'10"
	m	ft	m	ft	m	ft	m	ft
A	7.46	25'6"	7.45	24'5"	6.62	21'9"	6.82	22'5"
B	11.71	38'5"	12.12	39'9"	10.74	35'3"	11.20	36'9"
C	7.63	25'0"	8.18	26'10"	6.73	23'1"	7.23	23'9"
D	5.76	18'11"	5.89	19'4"	4.14	13'7"	4.57	15'0"
E	7.49	24'7"	8.05	26'5"	6.56	21'6"	7.08	23'3"
F	9.32	30'7"	9.34	30'8"	8.67	28'5"	8.86	29'1"
G	10.81	35'6"	10.73	35'2"	10.11	33'2"	10.30	33'10"

**349E L – VG
with Reach Boom**

**349E L – VG
with Mass Boom**

Stick	3.35 m	11'0"	3.9 m	12'10"	2.5 m	8'2"	3 m	9'10"
	m	ft	m	ft	m	ft	m	ft
A	7.61	25'0"	7.59	24'11"	6.72	22'1"	6.91	22'8"
B	11.68	38'4"	12.09	39'8"	10.76	35'4"	11.22	36'10"
C	7.49	24'7"	8.04	26'5"	6.64	21'9"	7.14	23'5"
D	5.17	17'0"	5.27	18'3"	3.91	12'10"	4.34	14'3"
E	7.34	24'1"	7.90	25'11"	6.74	22'1"	6.99	22'11"
F	9.47	31'1"	9.46	31'0"	8.82	28'11"	9.01	29'7"
G	10.87	35'8"	10.78	35'4"	10.24	33'7"	11.44	37'6"

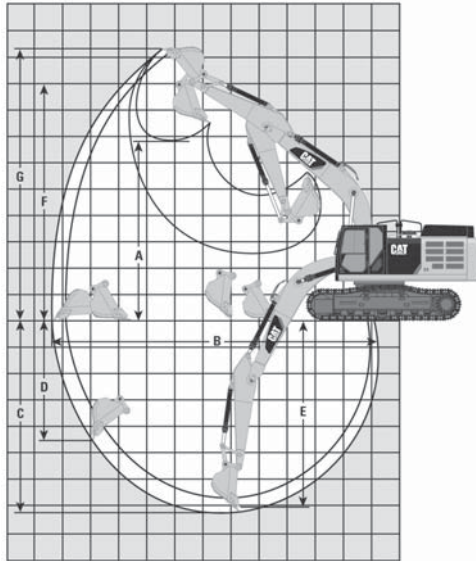

**One-Piece and VG Booms
Digging Envelope**

- Standard shoes and undercarriage

KEY:

- A** Maximum loading height of bucket with teeth
- B** Maximum reach at ground level
- C** Maximum digging depth
- D** Maximum vertical wall
- E** Maximum depth of cut for 2.44 m (8'0") level bottom (straight clean up)
- F** Maximum bucket hinge pin height
- G** Maximum height, to bucket teeth at highest arc

**349F L – FIX with
Long Reach Boom**

**349F L – FIX
with Reach Boom**

**349F L – FIX
with Mass Boom**

Stick	4.3 m		3.9 m		3.35 m		3 m		2.5 m	
	mm	ft	mm	ft	mm	ft	mm	ft	mm	ft
A	7870	25'10"	7420	24'4"	7430	24'5"	6740	22'1"	6550	21'6"
B	12 960	42'6"	12 150	39'10"	11 730	38'6"	11 270	37'0"	10 810	35'6"
C	8940	29'4"	8210	26'11"	7660	25'2"	7310	24'0"	6810	22'4"
D	6560	21'6"	5960	19'7"	5830	19'2"	4430	14'6"	4000	13'1"
E	8810	28'11"	8080	26'6"	7520	24'8"	7160	23'6"	6640	21'9"
F	—	—	—	—	—	—	—	—	—	—
G	11 170	36'8"	10 730	35'2"	10 820	35'6"	10 290	33'9"	10 090	33'1"

**352F – VG with
Long Reach Boom**

**352F – VG
with Reach Boom**

**352F – VG
with Mass Boom**

Stick	4.3 m		3.9 m		3.35 m		3 m		2.5 m	
	mm	ft	mm	ft	mm	ft	mm	ft	mm	ft
A	8020	26'4"	7570	24'10"	7580	24'10"	6900	22'8"	6700	22'0"
B	12 940	42'5"	12 120	39'9"	11 710	38'5"	11 240	36'11"	10 770	35'4"
C	8790	28'10"	8060	26'5"	7510	24'8"	7150	23'5"	6650	21'10"
D	6400	21'0"	5810	19'1"	5680	18'8"	4280	14'1"	3850	12'8"
E	8660	28'5"	7920	26'0"	7360	24'2"	7010	23'0"	6490	21'4"
F	—	—	—	—	—	—	—	—	—	—
G	11 320	37'2"	10 880	35'8"	10 970	36'0"	10 440	34'3"	10 250	33'8"

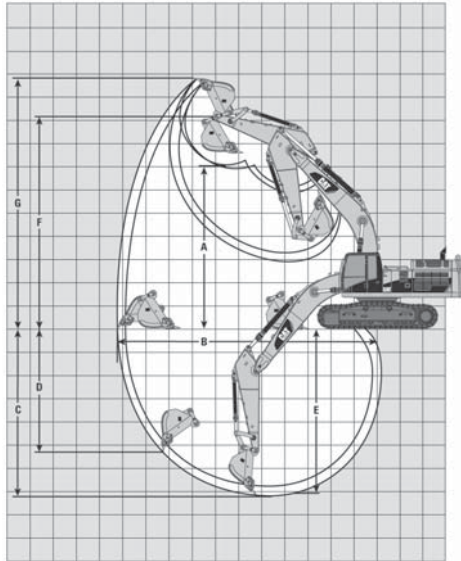

**One-Piece Boom
Digging Envelope**

- Standard shoes and undercarriage
- Lug height not included

KEY:

-
- A** Maximum loading height of bucket with teeth
 - B** Maximum reach at ground level
 - C** Maximum digging depth
 - D** Maximum vertical wall
 - E** Maximum depth of cut for 2.44 m (8'0") level bottom (straight clean up)
 - F** Maximum bucket hinge pin height
 - G** Maximum height, to bucket teeth at highest arc
-

374D L with Reach Boom

Stick	2.84 m		3.6 m		4.15 m		4.67 m	
	m	ft	m	ft	m	ft	m	ft
A	8.24	27'0"	8.41	27'7"	8.64	28'4"	8.99	29'6"
B	12.53	41'1"	13.17	43'3"	13.69	44'11"	14.23	46'8"
C	7.83	25'8"	8.59	28'2"	9.14	30'0"	9.66	31'8"
D	6.58	21'7"	7.05	23'2"	7.75	25'5"	8.45	27'9"
E	7.68	25'2"	8.46	27'9"	9.02	29'7"	9.55	31'4"
F	10.50	34'5"	10.66	35'0"	10.89	35'7"	11.25	36'9"
G	12.45	40'9"	12.44	40'8"	12.82	42'1"	13.21	43'3"

374D L with Mass Boom

Stick	2.57 m		3 m	
	m	ft	m	ft
A	7.07	23'2"	7.24	23'9"
B	11.46	37'7"	11.85	38'11"
C	7.23	23'9"	7.65	25'1"
D	3.96	13'0"	4.33	14'2"
E	7.07	23'2"	7.51	24'8"
F	9.37	30'7"	9.53	31'3"
G	11.01	36'1"	11.18	36'7"

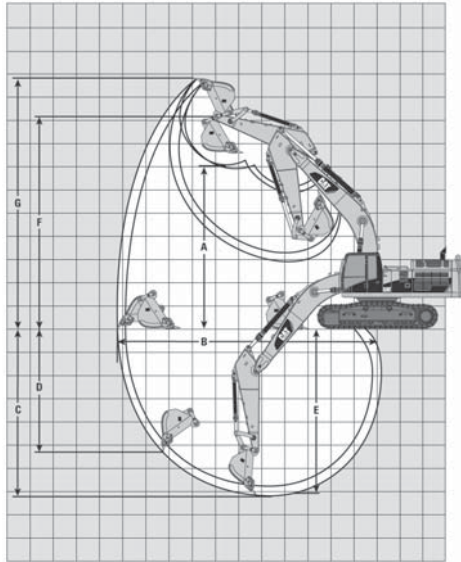

**One-Piece Boom
Digging Envelope**

- Standard shoes and undercarriage
- Lug height not included

KEY:

- A** Maximum loading height of bucket with teeth
- B** Maximum reach at ground level
- C** Maximum digging depth
- D** Maximum vertical wall
- E** Maximum depth of cut for 2.44 m (8'0") level bottom (straight clean up)
- F** Maximum bucket hinge pin height
- G** Maximum height, to bucket teeth at highest arc

374F L with Reach Boom

Stick	2.84 m	9'4"	3.6 m	11'10"	4.15 m	13'7"	4.67 m	15'4"
Bucket	GD3.8 m ³	5.0 yd ³	GD3.8 m ³	5.0 yd ³	GD3.8 m ³	5.0 yd ³	GD3.8 m ³	5.0 yd ³
	m	ft	m	ft	m	ft	m	ft
A	8.24	27'0"	8.41	27'7"	8.64	28'4"	9.00	29'6"
B	12.53	41'1"	13.17	43'2"	13.69	44'11"	14.23	46'8"
C	7.83	25'8"	8.59	28'2"	9.13	29'11"	9.65	31'8"
D	6.66	21'10"	7.13	23'5"	7.84	25'9"	8.53	28'0"
E	7.68	25'2"	8.46	27'9"	9.02	29'7"	9.55	31'4"
F	10.50	34'5"	10.66	35'0"	10.89	35'9"	11.25	36'11"
G	12.45	40'10"	12.44	40'10"	12.82	42'1"	13.21	43'4"

374F L with Mass Boom

Stick	2.57 m	8'5"	3 m	9'10"
Bucket	SDV4.6 m ³	6.0 yd ³	SDV4.6 m ³	6.0 yd ³
	m	ft	m	ft
A	7.07	23'2"	7.24	23'9"
B	11.46	37'7"	11.85	38'11"
C	7.23	23'9"	7.65	25'1"
D	4.04	13'3"	4.41	14'6"
E	7.07	23'2"	7.51	24'8"
F	9.37	30'9"	9.53	31'3"
G	11.01	36'2"	11.18	36'8"

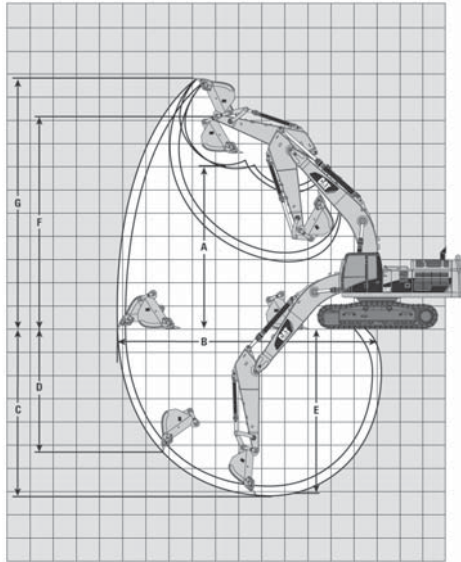

**One-Piece Boom
Digging Envelope**

- Standard shoes and undercarriage
- Lug height not included

KEY:

-
- A** Maximum loading height of bucket with teeth
 - B** Maximum reach at ground level
 - C** Maximum digging depth
 - D** Maximum vertical wall
 - E** Maximum depth of cut for 2.44 m (8'0") level bottom (straight clean up)
 - F** Maximum bucket hinge pin height
 - G** Maximum height, to bucket teeth at highest arc
-

**390D L with
Reach Boom**

**390D L with
General Purpose Boom**

Stick	4.4 m	14'5"	5.5 m	18'1"	2.92 m	9'7"	3.4 m	11'2"	3.7 m	12'2"
Bucket	HB3.9 m ³	5.1 yd ³	HB3.9 m ³	5.1 yd ³	JC4.6 m ³	6.0 yd ³	JC4.6 m ³	6.0 yd ³	HB4.6 m ³	6.0 yd ³
	m	ft	m	ft	mm	ft	m	ft	m	ft
A	10.52	34.51"	10.95	35.92"	8910	29.23"	9.09	29.82"	8.98	29.46"
B	16.23	53.24"	17.25	56.59"	13 480	44.22"	13.91	45.63"	14.04	46.06"
C	10.71	35.13"	11.81	38.74"	8220	26.96"	8.69	28.51"	8.96	29.39"
D	7.38	24.21"	8.39	27.52"	5950	19.52"	6.19	20.30"	5.94	19.48"
E	10.60	34.77"	11.71	38.41"	8080	26.50"	8.56	28.08"	8.84	29.00"
F	12.94	42.5"	13.37	43.9"	—	—	11.54	37.8"	11.40	37.4"
G	14.74	48.4"	15.17	49.8"	—	—	13.46	44.2"	13.19	43.3"

**390D L with
General Purpose Boom**

**390D L with
Mass Boom**

Stick	4.4 m	14'5"	5.5 m	18'1"	2.92 m	9'7"	3.4 m	11'2"
Bucket	HB4.6 m ³	6.0 yd ³	HB4.6 m ³	6.0 yd ³	JC6.0 m ³	7.8 yd ³	JC6.0 m ³	7.8 yd ³
	m	ft	m	ft	m	ft	m	ft
A	9.27	30.41"	9.72	31.88"	7.98	26.18"	8.20	26.90"
B	14.69	48.19"	15.73	51.60"	12.24	40.15"	12.69	41.63"
C	9.66	31.69"	10.76	35.30"	7.17	23.52"	7.65	25.09"
D	6.85	22.47"	7.86	25.78"	4.70	15.41"	5.10	16.73"
E	9.55	31.33"	10.66	34.97"	7.03	23.06"	7.52	24.67"
F	11.69	38.4"	12.15	39.9"	10.48	34.4"	10.70	35.1"
G	13.53	44.4"	13.99	45.9"	12.35	40.5"	12.57	41.2"

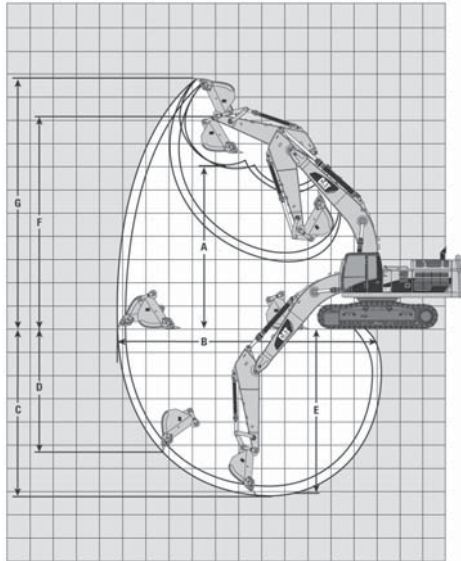

**One-Piece Boom
Digging Envelope**

- Standard shoes and undercarriage
- Lug height not included

KEY:

- A** Maximum loading height of bucket with teeth
- B** Maximum reach at ground level
- C** Maximum digging depth
- D** Maximum vertical wall
- E** Maximum depth of cut for 2.44 m (8'0") level bottom (straight clean up)
- F** Maximum bucket hinge pin height
- G** Maximum height, to bucket teeth at highest arc

**390F L with
Reach Boom**

**390F L with
General Purpose Boom**

Stick	4.4 m	14'5"	5.5 m	18'1"	2.92 m	9'7"	3.4 m	11'2"	3.7 m	12'2"
Bucket	GD3.9 m ³	5.1 yd ³	GD3.9 m ³	5.1 yd ³	SD4.6 m ³	6.0 yd ³	SD4.6 m ³	6.0 yd ³	SD4.6 m ³	6.0 yd ³
	m	ft	m	ft	mm	ft	m	ft	m	ft
A	10.53	34'7"	10.96	36'0"	8.92	29'3"	9.10	29'10"	8.99	29'6"
B	16.23	53'3"	17.25	56'7"	13.48	44'3"	13.91	45'8"	14.04	46'1"
C	10.70	35'1"	11.80	39'9"	8.21	26'11"	8.68	28'6"	8.95	29'4"
D	7.38	24'3"	8.38	27'6"	5.95	19'6"	6.18	20'3"	5.93	19'6"
E	10.59	34'9"	11.70	38'5"	8.07	26'6"	8.55	28'1"	8.83	29'0"
F	12.94	42'5"	13.37	43'10"	—	—	11.54	37'10"	11.40	37'5"
G	14.74	48'4"	15.17	49'9"	—	—	13.46	44'2"	13.19	43'3"

**390F L with
General Purpose Boom**

**390F L with
Mass Boom**

Stick	4.4 m	14'5"	5.5 m	18'1"	2.92 m	9'7"	3.4 m	11'2"
Bucket	GD4.6 m ³	6.0 yd ³	GD4.6 m ³	6.0 yd ³	SDV6.0 m ³	7.8 yd ³	SDV6.0 m ³	7.8 yd ³
	m	ft	m	ft	m	ft	m	ft
A	9.28	30'5"	9.73	31'11"	7.99	26'3"	8.21	26'11"
B	14.69	48'2"	15.73	51'7"	12.24	40'2"	12.69	41'8"
C	9.65	31'8"	10.75	35'3"	7.16	23'6"	7.64	25'1"
D	6.85	22'6"	7.86	25'9"	4.69	15'5"	5.09	16'8"
E	9.54	31'4"	10.65	34'11"	7.02	23'0"	7.51	24'8"
F	11.69	38'4"	12.15	39'10"	10.48	34'5"	10.70	35'1"
G	13.53	44'5"	13.99	45'11"	12.35	40'6"	12.57	41'3"

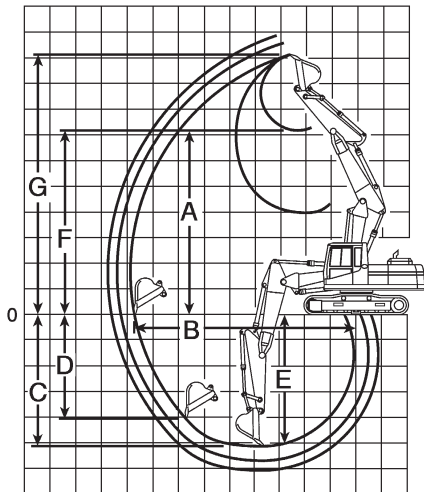

**Hydraulically Adjustable Boom
Digging Envelope**

KEY:

- A** Maximum loading height of bucket with teeth
- B** Maximum reach at ground level
- C** Maximum digging depth
- D** Maximum vertical wall
- E** Maximum depth of cut for 2.44 m (8'0") level bottom (straight clean up)
- F** Maximum bucket hinge pin height
- G** Maximum height, to bucket teeth at highest arc

312D, 312D L

Stick	2.1 m		6'11"		2.5 m		8'2"		3 m		9'10"	
	m	ft	m	ft	m	ft	m	ft	m	ft		
A	6.91	22'8"	7.27	23'10"	7.65	25'1"						
B	7.84	25'8"	8.22	27'0"	8.68	28'6"						
C	4.73	15'6"	5.13	16'10"	5.61	18'5"						
D	2.84	9'4"	3.16	10'5"	3.64	11'11"						
E	4.54	14'11"	4.9	16'1"	5.34	17'6"						
F	8.03	26'4"	8.36	27'5"	8.77	28'10"						
G	9.14	30'0"	9.49	31'1"	9.89	32'5"						

315D L

Stick	1.85 m		6'1"		2.25 m		7'5"		2.6 m		8'6"		3.1 m		10'2"	
	m	ft	m	ft	m	ft	m	ft	m	ft	m	ft				
A	6.92	22'8"	7.26	23'10"	7.45	24'5"	7.81	25'7"								
B	7.97	26'2"	8.36	27'5"	8.68	28'6"	9.10	29'10"								
C	4.65	15'4"	5.06	16'7"	5.40	17'8"	5.85	19'2"								
D	3.12	10'2"	3.52	11'7"	3.88	12'8"	4.36	14'4"								
E	4.59	15'0"	4.99	16'5"	5.34	17'6"	5.81	19'1"								
F	8.21	26'11"	8.54	28'0"	8.77	28'10"	9.10	29'11"								
G	9.49	31'1"	9.82	32'2"	10.09	33'1"	10.40	34'1"								

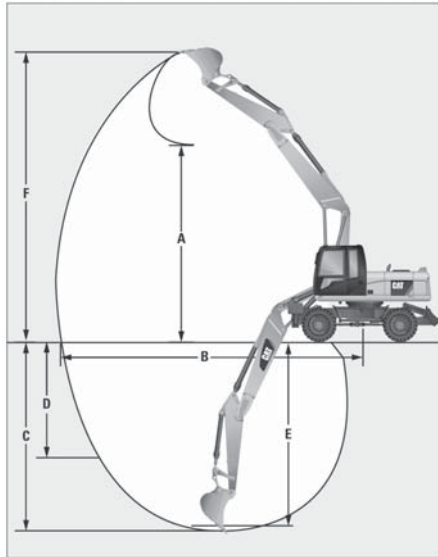

Hydraulically Adjustable Boom Digging Envelope

- Standard dual 10.00-20 tires and undercarriage
- General purpose bucket

KEY:

- A** Maximum loading height of bucket with teeth
- B** Maximum reach at ground level
- C** Maximum digging depth
- D** Maximum vertical wall
- E** Maximum depth of cut for 2.5 m (8'2") level bottom
- F** Maximum height, to bucket teeth at highest arc

M313D

M315D

Stick	2 m 6'7"		2.3 m 7'7"		2.6 m 8'6"		2.1 m 6'11"		2.4 m 7'10"		2.6 m 8'6"	
	0.64 m ³ 0.84 yd ³		0.64 m ³ 0.84 yd ³		0.56 m ³ 0.73 yd ³		0.815 m ³ 1.07 yd ³		0.7 m ³ 0.92 yd ³		0.7 m ³ 0.92 yd ³	
Bucket	m	ft	m	ft	m	ft	m	ft	m	ft	m	ft
A	6.90	22'8"	7.06	23'2"	7.29	23'11"	6.95	22'10"	7.14	23'5"	7.30	23'11"
B	8.49	27'10"	8.74	28'8"	9.03	29'7"	8.91	29'3"	9.19	30'2"	9.38	30'9"
C	5.16	16'11"	5.45	17'11"	5.75	18'10"	5.59	18'4"	5.89	19'4"	6.09	20'0"
D	3.50	11'6"	3.60	11'10"	3.89	12'9"	3.72	12'2"	3.92	12'10"	4.09	13'5"
E	4.92	16'2"	5.23	17'2"	5.55	18'2"	5.37	17'7"	5.69	18'8"	5.90	19'4"
F	9.67	31'9"	9.82	32'3"	10.06	33'0"	10.04	32'11"	10.23	33'7"	10.38	34'1"

M315D2

M316D

Stick	2 m 6'7"		2.3 m 7'7"		2.6 m 8'6"		2.1 m 6'11"		2.4 m 7'10"		2.6 m 8'6"	
	0.7 m ³ 0.92 yd ³		0.7 m ³ 0.92 yd ³		0.7 m ³ 0.92 yd ³		0.815 m ³ 1.07 yd ³		0.815 m ³ 1.07 yd ³		0.7 m ³ 0.92 yd ³	
Bucket	mm	ft	mm	ft	mm	ft	m	ft	m	ft	m	ft
A	7060	23'2"	7210	23'8"	7440	24'5"	6.97	22'10"	7.16	23'6"	7.32	24'0"
B	8330	27'4"	8580	28'2"	8880	29'2"	8.91	29'3"	9.19	30'2"	9.38	30'9"
C	5010	16'5"	5300	17'5"	5600	18'4"	5.57	18'3"	5.87	19'3"	6.07	19'11"
D	3680	12'1"	3810	12'6"	4100	13'5"	3.70	12'2"	3.90	12'10"	4.07	13'4"
E	4760	15'7"	5070	16'8"	5390	17'8"	5.35	17'7"	5.67	18'7"	5.88	19'3"
F	9520	31'3"	9670	31'9"	9910	32'6"	10.06	33'0"	10.25	33'7"	10.40	34'1"

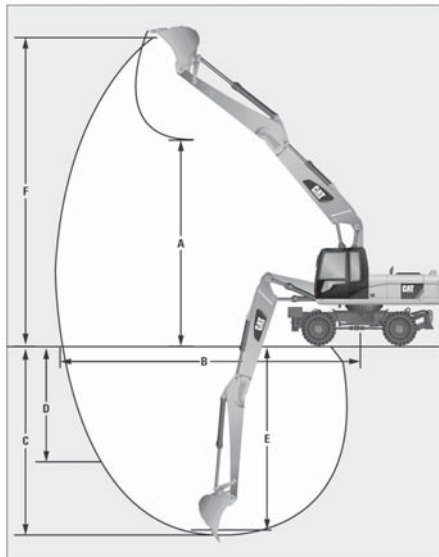

**Hydraulically Adjustable Boom
Digging Envelope**

- Standard dual 10.00-20 tires and undercarriage for M317D2, M318D and M320D2
- Standard dual 11.00-20 tires and undercarriage for M322D
- General purpose bucket

KEY:

- A** Maximum loading height of bucket with teeth
- B** Maximum reach at ground level
- C** Maximum digging depth
- D** Maximum vertical wall
- E** Maximum depth of cut for 2.5 m (8'2") level bottom
- F** Maximum height, to bucket teeth at highest arc

M317D2

M318D

Stick	2.1 m	6'11"	2.4 m	7'10"	2.6 m	8'6"	2.2 m	7'3"	2.5 m	8'2"	2.8 m	9'2"
Bucket	0.8 m ³	1.05 yd ³	0.8 m ³	1.05 yd ³	0.8 m ³	1.05 yd ³	0.91 m ³	1.19 yd ³	0.91 m ³	1.19 yd ³	0.7 m ³	0.92 yd ³
	mm	ft	mm	ft	mm	ft	m	ft	m	ft	m	ft
A	7100	23'4"	7280	23'11"	7440	24'5"	6.70	22'0"	6.97	22'10"	7.19	23'7"
B	8770	28'9"	9040	29'8"	9240	30'4"	8.97	29'5"	9.30	30'6"	9.59	31'5"
C	5450	17'11"	5740	18'10"	5930	19'5"	5.75	18'10"	6.06	19'11"	6.36	20'10"
D	4070	13'4"	4280	14'1"	4460	14'7"	3.22	10'7"	3.68	12'1"	3.96	13'0"
E	5220	17'2"	5530	18'2"	5740	18'10"	5.54	18'2"	5.87	19'3"	6.18	20'3"
F	9910	32'6"	10 090	33'1"	10 250	33'8"	9.71	31'10"	10.00	32'10"	10.21	33'6"

M320D2

M322D

Stick	2.2 m	7'3"	2.5 m	8'2"	2.8 m	9'2"	2.2 m	7'3"	2.5 m	8'2"	2.9 m	9'6"
Bucket	0.9 m ³	1.18 yd ³	0.9 m ³	1.18 yd ³	0.7 m ³	0.92 yd ³	1.04 m ³	1.36 yd ³	0.805 m ³	1.05 yd ³	0.805 m ³	1.05 yd ³
	mm	ft	mm	ft	mm	ft	m	ft	m	ft	m	ft
A	6850	22'6"	7120	23'4"	7330	24'1"	6.93	22'9"	7.17	23'6"	7.50	24'7"
B	8820	28'11"	9140	30'0"	9430	30'11"	9.59	31'5"	9.83	32'3"	10.23	33'7"
C	5600	18'4"	5900	19'4"	6200	20'4"	5.99	19'8"	6.28	20'7"	6.68	21'11"
D	3920	12'10"	4290	14'1"	4580	15'0"	4.42	14'6"	4.45	14'7"	4.83	15'10"
E	5390	17'8"	5700	18'8"	6010	19'9"	5.78	19'0"	6.09	20'0"	6.51	21'4"
F	9580	31'5"	9870	32'5"	10 080	33'1"	10.56	34'8"	10.62	34'10"	10.93	35'10"

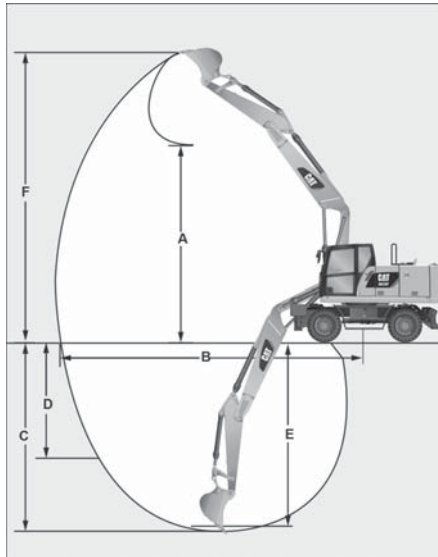

**Hydraulically Adjustable Boom
Digging Envelope**

- Standard dual 10.00-20 tires and undercarriage for M316D and M318D
- Standard dual 11.00-20 tires and undercarriage for M322D
- General purpose bucket

KEY:

- A** Maximum loading height of bucket with teeth
- B** Maximum reach at ground level
- C** Maximum digging depth
- D** Maximum vertical wall
- E** Maximum depth of cut for 2.5 m (8'2") level bottom
- F** Maximum height, to bucket teeth at highest arc

M314F

M316F

Stick	2.0 m 6'7"		2.3 m 7'7"		2.6 m 8'6"		2.1 m 6'11"		2.4 m 7'10"		2.6 m 8'6"	
	0.68 m ³ 0.89 yd ³		0.68 m ³ 0.89 yd ³		0.68 m ³ 0.89 yd ³		0.8 m ³ 1.05 yd ³		0.8 m ³ 1.05 yd ³		0.8 m ³ 1.05 yd ³	
Bucket	mm	ft	mm	ft	mm	ft	mm	ft	mm	ft	mm	ft
A	3550	11'8"	3210	10'6"	2930	9'7"	3440	11'3"	3120	10'3"	2940	9'8"
B	8335	27'4"	8590	28'2"	8885	29'2"	8760	28'9"	9040	29'8"	9230	30'3"
C	5010	16'5"	5300	17'5"	5600	18'4"	5450	17'11"	5740	18'10"	5940	19'6"
D	3830	12'7"	3960	13'0"	4250	13'11"	4250	13'11"	4480	14'8"	4660	15'3"
E	4890	16'1"	5185	17'0"	5485	18'0"	5330	17'6"	5630	18'6"	5830	19'2"
F	9520	31'3"	9655	31'8"	9895	32'6"	8890	29'2"	10 070	33'0"	10 230	33'7"

M318F

M320F

Stick	2.1 m 6'11"		2.4 m 7'10"		2.6 m 8'6"		2.5 m 8'2"		2.8 m 9'2"	
	0.8 m ³ 1.05 yd ³		0.8 m ³ 1.05 yd ³		0.8 m ³ 1.05 yd ³		0.9 m ³ 1.18 yd ³		0.7 m ³ 0.92 yd ³	
Bucket	mm	ft	mm	ft	mm	ft	mm	ft	mm	ft
A	7120	23'4"	7300	23'11"	7460	24'6"	6970	22'10"	7180	23'7"
B	8760	28'9"	9040	29'8"	9230	30'3"	9195	30'2"	9490	31'2"
C	5430	17'10"	5720	18'9"	5920	19'5"	5960	19'7"	6260	20'6"
D	4230	13'11"	4460	14'8"	4640	15'3"	4495	14'9"	4785	15'8"
E	5310	17'5"	5610	18'5"	5810	19'1"	5860	19'3"	6160	20'3"
F	9910	32'6"	10 090	33'1"	10 250	33'8"	9885	32'5"	10 100	33'2"

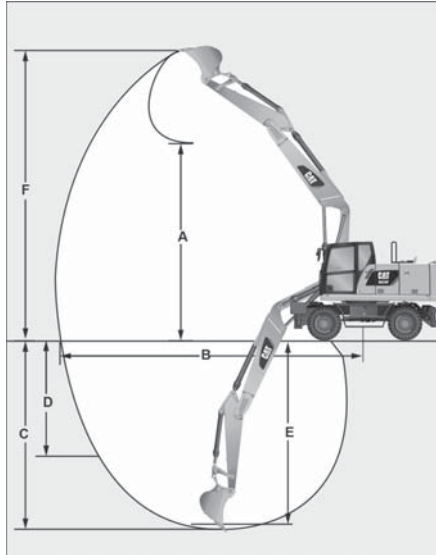

**Hydraulically Adjustable Boom
Digging Envelope**

- Standard dual 11.00-20 tires and undercarriage
- General purpose bucket

KEY:

-
- A** Maximum loading height of bucket with teeth
 - B** Maximum reach at ground level
 - C** Maximum digging depth
 - D** Maximum vertical wall
 - E** Maximum depth of cut for 2.5 m (8'2") level bottom
 - F** Maximum height, to bucket teeth at highest arc
-

M322F

Stick	2.2 m	7'3"	2.5 m	8'2"	2.9 m	9'6"
Bucket	1.19 m ³	1.56 yd ³	1.19 m ³	1.56 yd ³	1.19 m ³	1.56 yd ³
	mm	ft	mm	ft	mm	ft
A	3345	11'0"	2975	9'9"	2585	8'6"
B	9420	30'11"	9660	31'8"	10 055	34'7"
C	5825	19'1"	6115	20'1"	6515	21'4"
D	4545	14'11"	4570	15'0"	4940	16'2"
E	5720	18'9"	6020	19'9"	6425	21'1"
F	10 385	34'1"	10 410	34'2"	10 720	35'2"

EXCAVATOR LIFTING CAPACITY

On many sewer jobs an excavator must lift and swing heavy pipe and manboxes in and out of the trench, place manholes and unload material from trucks. In some situations the excavator's lift requirements may be so critical that they determine the size excavator selected.

An excavator's lift capacity depends on its weight, center of gravity, the lift point position (see sketches) and its hydraulic capability. An excavator's lifting capability for any given lift position is limited by its tipping stability or hydraulic capacity.

Changes in boom, stick and bucket position affect attachment geometry and can drastically change a machine's hydraulic lifting capacity. Caterpillar defines excavator lifting capabilities using the following SAE guidelines.

Tipping Conditions — An excavator is considered to be at the tipping point when the weight in the bucket acting at the center of gravity causes the rear rollers to lift clear of the track rails. Suspended loads are considered to be hung from the back of the excavator's bucket or bucket linkage by a sling or chain. Weights of attachments, slings or auxiliary lifting devices are considered part of the suspended load.

Thus, the tipping load is defined as the load producing a tipping condition at a specified radius. The load radius shall be measured as the horizontal distance from the axis of upper structure rotation (before loading) to the center of vertical load line with load applied (dimension A, below). The rating height is based on the vertical distance of the bucket lift point to the ground (dimension B).

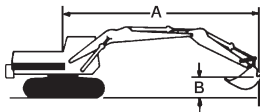

- A. Radius from swing centerline
- B. Bucket lift point height

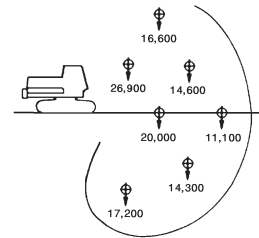

HYPOTHETICAL MACHINE

Rated Hoist Load — The rated load is established using the vertical distance of the lifting point to the ground and the radius of load. Ratings for the ability of a specific machine attachment to lift a load slung from the designated bucket are defined as follows:

- a. The rated load will not exceed 75% of the tipping load.
- b. The rated load will not exceed 87% of the excavator's hydraulic capacity. This means the machine should be able to lift 115% of the rated load.
- c. The rated load will not exceed the machine's structural capability.

This drawing shows how an excavator's lifting capacity can vary with load position:

**HYPOTHETICAL
MACHINE**

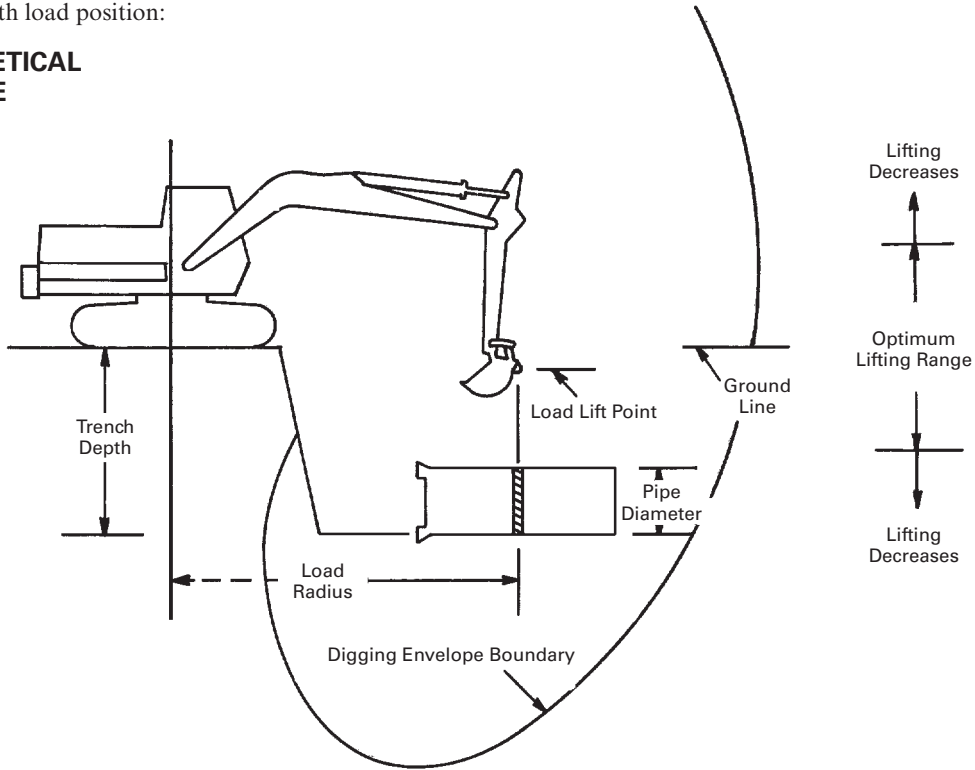

Tips for Lifting Above Ground:

Get the load as close to the excavator as possible.

Use a cable short enough and position the excavator so as to put the load lift point in the “optimum lifting range” (see sketch).

Problem: Long reach cable — Can't lift.

Solution: Shorten reach and cable — Can lift.

Tips for Lifting Below Grade:

Use a cable for sufficient length to position the load lift point in the “optimum lifting range”.

Problem: Short cable, deep trench — Can't lift.

Solution: Lengthen cable to locate bucket hinge pin in optimum lifting area — Can lift.

GROUND LEVEL LIFTING CAPACITIES

The lifting capacities that are shown on the following pages are with the lifting point at ground level. These capacities are rated according to SAE Std. No. J1097.

(For lifting capacities at other heights or with other tools, refer to current Specification Sheets.)

300.9D ● Rubber Track ● Canopy ● Blade Raised

Stick 0.89 m 2'9"	kg lb	1 m 3'3"	1.5 m 5'0"	2 m 6'7"	2.5 m 8'2"	At Max. Reach Front
		Front	Front	Front	Front	
		570	296	197	145	137
		1257	653	434	319	303

300.9D ● Rubber Track ● Canopy ● Blade Lowered

Stick 0.89 m 2'9"	kg lb	1 m 3'3"	1.5 m 5'0"	2 m 6'7"	2.5 m 8'2"	At Max. Reach Front
		Front	Front	Front	Front	
		678	379	247	171	155
		1495	835	546	377	343

301.4C ● Rubber Track ● Canopy ● Blade Raised

Stick 1.10 m 3'6"	kg lb	1.5 m 5'0"		2 m 6'7"		2.5 m 8'2"		3 m 9'10"		At Max. Reach	
		Front	Side	Front	Side	Front	Side	Front	Side	Front	Side
Undercarriage Retracted		—	—	—	—	—	—	—	—	—	—
Undercarriage Extended		—	—	—	—	—	—	—	—	—	—

301.4C ● Rubber Track ● Canopy ● Blade Lowered

Stick 1.10 m 3'6"	kg lb	1.5 m 5'0"		2 m 6'7"		2.5 m 8'2"		3 m 9'10"		At Max. Reach	
		Front	Side	Front	Side	Front	Side	Front	Side	Front	Side
Undercarriage Retracted		—	—	715	335	—	—	385	200	350	190
				1576	738			849	441	771	419
Undercarriage Extended		—	—	715	495	—	—	385	300	350	275
				1576	1091			849	661	771	606

301.7D ● Rubber Track ● Canopy ● Blade Raised

Stick 1180 mm 3'10"	kg lb	1.5 m 5'0"		2 m 6'7"		2.5 m 8'2"		3 m 9'10"		At Max. Reach	
		Front	Side	Front	Side	Front	Side	Front	Side	Front	Side
Undercarriage Retracted		600	573	400	387	296	289	232	227	198	195
		1323	1263	882	853	653	637	511	500	437	430
Undercarriage Extended		600	883	400	569	296	416	232	324	198	277
		1323	1947	882	1254	653	917	511	714	437	611

301.7D ● Rubber Track ● Canopy ● Blade Lowered

Stick 1180 mm 3'10"	kg lb	1.5 m 5'0"		2 m 6'7"		2.5 m 8'2"		3 m 9'10"		At Max. Reach	
		Front	Side	Front	Side	Front	Side	Front	Side	Front	Side
Undercarriage Retracted		1271	573	793	387	573	289	454	227	393	195
		2802	1263	1748	853	1263	637	1001	500	866	430
Undercarriage Extended		1271	883	793	569	573	416	454	324	393	277
		2802	1947	1748	1254	1263	917	1001	714	866	611

301.7D CR ● Rubber Track ● Canopy ● Blade Raised

Stick 1.10 m 3'6"	kg lb	1.5 m 5'0"		2 m 6'7"		2.5 m 8'2"		3 m 9'10"		At Max. Reach	
		Front	Side	Front	Side	Front	Side	Front	Side	Front	Side
Undercarriage Extended		—	—	336	373	240	269	182	206	144	165
				742	823	529	594	400	454	317	363

302.2D ● Undercarriage Extended

Stick		1.5 m 5'0"		2 m 6'7"		2.5 m 8'2"		3 m 9'10"		At Max. Reach	
		Front	Side	Front	Side	Front	Side	Front	Side	Front	Side
Standard Stick	kg	—	—	887	557	639	408	501	319	420	267
	lb	—	—	1957	1228	1409	900	1104	703	925	589
Long Stick	kg	—	—	863	548	616	400	484	311	382	240
	lb	—	—	1904	1207	1359	882	1066	686	842	529

302.4D ● Rubber Track ● Canopy ● Blade Raised

Stick		2 m 6'7"		2.5 m 8'2"		3 m 9'10"		3.5 m 11'6"		At Max. Reach	
		Front	Side	Front	Side	Front	Side	Front	Side	Front	Side
1050 mm 3'5"	kg	600	735	428	533	329	415	—	—	276	351
	lb	1323	1620	944	1175	725	915	—	—	608	774
1250 mm 4'1"	kg	593	727	421	526	320	406	255	327	247	318
	lb	1307	1603	928	1160	705	895	562	721	545	701

302.4D ● Rubber Track ● Canopy ● Blade Lowered

Stick		2 m 6'7"		2.5 m 8'2"		3 m 9'10"		3.5 m 11'6"		At Max. Reach	
		Front	Side	Front	Side	Front	Side	Front	Side	Front	Side
1050 mm 3'5"	kg	1285	735	932	533	730	415	—	—	615	351
	lb	2833	1620	2055	1175	1609	915	—	—	1356	774
1250 mm 4'1"	kg	1272	727	910	526	714	406	574	327	566	318
	lb	2804	1603	2006	1160	1574	895	1265	721	1248	701

302.7D ● Rubber Track ● Canopy ● Blade Raised

Stick	Bucket		2 m 6'7"		2.5 m 8'2"		3 m 9'10"		3.5 m 11'6"		At Max. Reach	
			Front	Side	Front	Side	Front	Side	Front	Side	Front	Side
1100 mm 3'6"	400 mm 16"	kg	—	—	—	—	—	—	—	—	—	—
		lb	—	—	—	—	—	—	—	—	—	—
1400 mm 4'6"	400 mm 16"	kg	—	—	—	—	—	—	—	—	—	—
		lb	—	—	—	—	—	—	—	—	—	—

302.7D ● Rubber Track ● Canopy ● Blade Lowered

Stick	Bucket		2 m 6'7"		2.5 m 8'2"		3 m 9'10"		3.5 m 11'6"		At Max. Reach	
			Front	Side	Front	Side	Front	Side	Front	Side	Front	Side
1100 mm 3'6"	400 mm 16"	kg	—	—	965	560	730	435	585	355	510	320
		lb	—	—	2127	1235	1609	959	1290	783	1124	705
1400 mm 4'6"	400 mm 16"	kg	—	—	955	623	720	483	580	394	470	332
		lb	—	—	2127	1373	1587	1065	1278	868	1036	732

303E CR ● Blade Raised

Stick		2.5 m 8'2"		3 m 9'10"		3.5 m 11'6"		4 m 13'1"		4.5 m 15'0"		5 m 16'5"		At Max. Reach	
		Front	Side	Front	Side	Front	Side	Front	Side	Front	Side	Front	Side	Front	Side
1260 mm	kg	1040	910	—	—	600	530	490	430	—	—	—	—	400	360
4'2"	lb	2230	1950	—	—	1290	1140	1040	930	—	—	—	—	880	790
1560 mm	kg	1010	880	750	660	580	520	470	420	380	340	—	—	350	310
5'1"	lb	2170	1890	1600	1410	1250	1100	1000	890	820	730	—	—	770	680

303E CR ● Blade Lowered

Stick		2.5 m 8'2"		3 m 9'10"		3.5 m 11'6"		4 m 13'1"		4.5 m 15'0"		5 m 16'5"		At Max. Reach	
		Front	Side	Front	Side	Front	Side	Front	Side	Front	Side	Front	Side	Front	Side
1260 mm	kg	1790	1000	1170	540	1080	580	880	470	—	—	—	—	720	390
4'2"	lb	3850	2130	2579	1190	2320	1250	1890	1010	—	—	—	—	1580	860
1560 mm	kg	1820	970	1340	720	1040	560	850	460	720	370	—	—	650	340
5'1"	lb	3900	2080	2870	1550	2240	1210	1830	970	1530	800	—	—	1430	750

303.5E CR ● Blade Raised

Stick		2.5 m 8'2"		3 m 9'10"		3.5 m 11'6"		4 m 13'1"		4.5 m 15'0"		5 m 16'5"		At Max. Reach	
		Front	Side	Front	Side	Front	Side	Front	Side	Front	Side	Front	Side	Front	Side
1260 mm	kg	1040	910	770	680	600	530	490	430	—	—	—	—	400	360
4'2"	lb	2290	2000	1690	1490	1320	1160	1080	940	—	—	—	—	880	790
1560 mm	kg	1010	880	750	660	580	520	470	420	380	340	—	—	350	310
5'1"	lb	2220	1940	1650	1450	1270	1140	1030	920	830	750	—	—	770	680

303.5E CR ● Blade Lowered

Stick		2.5 m 8'2"		3 m 9'10"		3.5 m 11'6"		4 m 13'1"		4.5 m 15'0"		5 m 16'5"		At Max. Reach	
		Front	Side	Front	Side	Front	Side	Front	Side	Front	Side	Front	Side	Front	Side
1260 mm	kg	1790*	1000	1370*	740	1080*	580	880*	470	—	—	—	—	720*	390
4'2"	lb	3940*	2200	3020*	1630	2380*	1270	1940*	1030	—	—	—	—	1580*	860
1560 mm	kg	1820*	970	1340*	720	1040*	560	850*	460	720*	370	—	—	650*	340
5'1"	lb	4010*	2130	2950*	1580	2290*	1230	1870*	1010	1580*	810	—	—	1430*	750

303.5E2 CR ● Blade Raised

Stick		2.5 m 8'2"		3 m 9'10"		3.5 m 11'6"		4 m 13'1"		4.5 m 15'0"		5 m 16'5"		At Max. Reach	
		Front	Side	Front	Side	Front	Side	Front	Side	Front	Side	Front	Side	Front	Side
1260 mm	kg	1040	910	770	680	600	530	490	430	—	—	—	—	400	360
4'2"	lb	2290	2000	1690	1490	1320	1160	1080	940	—	—	—	—	880	790
1560 mm	kg	1010	880	750	660	580	520	470	420	380	340	—	—	350	310
5'1"	lb	2220	1940	1650	1450	1270	1140	1030	920	830	750	—	—	770	680

303.5E2 CR ● Blade Lowered

Stick		2.5 m 8'2"		3 m 9'10"		3.5 m 11'6"		4 m 13'1"		4.5 m 15'0"		5 m 16'5"		At Max. Reach	
		Front	Side	Front	Side	Front	Side	Front	Side	Front	Side	Front	Side	Front	Side
1260 mm	kg	1790*	1000	1370*	740	1080*	580	880*	470	—	—	—	—	720*	390
4'2"	lb	3940*	2200	3020*	1630	2380*	1270	1940*	1030	—	—	—	—	1580*	860
1560 mm	kg	1820*	970	1340*	720	1040*	560	850*	460	720*	370	—	—	650*	340
5'1"	lb	4010*	2130	2950*	1580	2290*	1230	1870*	1010	1580*	810	—	—	1430*	750

*Load limited by hydraulic capacity rather than tipping.

304E2 CR ● Blade Raised

Stick		2.5 m 8'2"		3 m 9'10"		3.5 m 11'6"		4 m 13'1"		4.5 m 15'0"		5 m 16'5"		At Max. Reach	
		Front	Side	Front	Side	Front	Side	Front	Side	Front	Side	Front	Side	Front	Side
1315 mm	kg	1120	1120	830	830	650	650	530	530	440	440	—	—	420	420
4'4"	lb	2460	2460	1830	1830	1430	1430	1160	1160	970	970	—	—	920	920
1615 mm	kg	1110	1100	820	820	640	640	520	520	430	430	—	—	370	370
5'4"	lb	2440	2420	1800	1800	1410	1410	1140	1140	940	940	—	—	810	810

304E2 CR ● Blade Lowered

Stick		2.5 m 8'2"		3 m 9'10"		3.5 m 11'6"		4 m 13'1"		4.5 m 15'0"		5 m 16'5"		At Max. Reach	
		Front	Side	Front	Side	Front	Side	Front	Side	Front	Side	Front	Side	Front	Side
1315 mm	kg	2130*	1240	1610*	920	1260*	720	1040*	590	870*	490	—	—	740*	470
4'4"	lb	4690*	2730	3540*	2020	2770*	1580	2290*	1300	1910*	1080	—	—	1630*	1030
1615 mm	kg	2150*	1230	1570*	910	1220*	720	1000*	580	860*	480	—	—	760*	420
5'4"	lb	4740*	2710	3460*	2000	2690*	1580	2200*	1270	1890*	1050	—	—	1670*	920

305E2 CR ● Blade Raised

Stick		2.5 m 8'2"		3 m 9'10"		3.5 m 11'6"		4 m 13'1"		4.5 m 15'0"		5 m 16'5"		At Max. Reach	
		Front	Side	Front	Side	Front	Side	Front	Side	Front	Side	Front	Side	Front	Side
1350 mm	kg	1950	1390	1450	1070	1130	840	920	690	760	570	—	—	670	510
4'4"	lb	4290	3060	3190	2350	2490	1850	2020	1520	1670	1250	—	—	1470	1120
1750 mm	kg	1950	1390	1420	1040	1100	820	890	660	740	550	620	460	560	410
5'7"	lb	4290	3060	3130	2290	2420	1800	1960	1450	1630	1210	1360	1010	1230	900

305E2 CR ● Blade Lowered

Stick		2.5 m 8'2"		3 m 9'10"		3.5 m 11'6"		4 m 13'1"		4.5 m 15'0"		5 m 16'5"		At Max. Reach	
		Front	Side	Front	Side	Front	Side	Front	Side	Front	Side	Front	Side	Front	Side
1350 mm	kg	2100*	1580	2340*	1200	1820*	940	1480*	770	1260*	640	—	—	1000*	570
4'4"	lb	4630*	3480	5150*	2640	4010*	2070	3260*	1690	2770*	1410	—	—	2200*	1250
1750 mm	kg	2270*	1580	2250*	1170	1720*	920	1390*	740	1190*	620	1040*	520	870*	480
5'7"	lb	5000*	3480	4960*	2570	3790*	2020	3060*	1630	2620*	1360	2290*	1140	1910*	1050

305.5E2 CR ● Blade Raised

Stick		2.5 m 8'2"		3 m 9'10"		3.5 m 11'6"		4 m 13'1"		4.5 m 15'0"		5 m 16'5"		At Max. Reach	
		Front	Side	Front	Side	Front	Side	Front	Side	Front	Side	Front	Side	Front	Side
1420 mm	kg	—	—	1550	1150	1210	910	980	740	820	620	—	—	680	520
4'7"	lb	—	—	3410	2530	2660	2000	2160	1630	1800	1360	—	—	1490	1140
1820 mm	kg	2080	1490	1520	1110	1180	880	950	710	790	590	670	500	580	430
5'10"	lb	4580	3280	3350	2440	2600	1940	2090	1560	1740	1300	1470	1100	1270	940

305.5E2 CR ● Blade Lowered

Stick		2.5 m 8'2"		3 m 9'10"		3.5 m 11'6"		4 m 13'1"		4.5 m 15'0"		5 m 16'5"		At Max. Reach	
		Front	Side	Front	Side	Front	Side	Front	Side	Front	Side	Front	Side	Front	Side
1420 mm	kg	—	—	2590*	1290	2010*	1020	1630*	830	1380*	690	—	—	1110*	580
4'7"	lb	—	—	5710*	2840	4430*	2240	3590*	1830	3040*	1520	—	—	2440*	1270
1820 mm	kg	2270*	1690	2490*	1250	1890*	990	1530*	800	1290*	660	1140*	560	900*	480
5'10"	lb	5000*	3720	5490*	2750	4160*	2180	3370*	1760	2840*	1450	2510*	1230	1980*	1050

*Load limited by hydraulic capacity rather than tipping.

307E2 ● Blade Raised

Stick		2.5 m 8'2"		3 m 9'10"		3.5 m 11'6"		4 m 13'1"		4.5 m 15'0"		5 m 16'5"		At Max. Reach	
		Front	Side	Front	Side	Front	Side	Front	Side	Front	Side	Front	Side	Front	Side
1665 mm	kg	—	—	2620	2260	2050	1790	1670	1470	1390	1230	1180	1040	1010*	930
5'6"	lb	—	—	5770	4980	4510	3940	3680	3240	3060	2710	2600	2290	2220	2050

307E2 ● Blade Lowered

Stick		2.5 m 8'2"		3 m 9'10"		3.5 m 11'6"		4 m 13'1"		4.5 m 15'0"		5 m 16'5"		At Max. Reach	
		Front	Side	Front	Side	Front	Side	Front	Side	Front	Side	Front	Side	Front	Side
1665 mm	kg	—	—	3640*	2580	3090*	2030	2670*	1650	2340*	1380	2070*	1170	1010*	1010*
5'6"	lb	—	—	8020*	5680	6810*	4470	5880*	3630	5150*	3040	4560*	2570	2220*	2220*

308E2 CR SB ● 450 mm (18") Track Shoes ● Blade Lowered ● 600 mm (24") Bucket

Stick		2 m 6'7"		3 m 9'10"		4 m 13'1"		At Max. Reach	
		Front	Side	Front	Side	Front	Side	Front	Side
1665 mm	kg	—	—	—	—	3650	1710	1880	920
5'6"	lb	—	—	—	—	7830	3680	4140	2010
2210 mm	kg	—	—	—	—	3460	1680	1640	770
7'3"	lb	—	—	—	—	7410	3620	3610	1690

308E2 CR SB ● 600 mm (24") Track Shoes ● Blade Lowered ● 600 mm (24") Bucket

Stick		2 m 6'7"		3 m 9'10"		4 m 13'1"		At Max. Reach	
		Front	Side	Front	Side	Front	Side	Front	Side
1665 mm	kg	—	—	3710	3060	3750	1980	2310	1200
5'6"	lb	—	—	8600	6570	8070	4270	5100	2640
2210 mm	kg	—	—	3610	2780	3540	1810	2010	960
7'3"	lb	—	—	8390	5960	7620	3900	4430	2100

*Load limited by hydraulic capacity rather than tipping.

Japan

311F L RR ● 500 mm (20") Track Shoes ● Standard Counterweight
● Reach Boom ● No Bucket

Stick		3 m 9'10"		4.5 m 15'0"		6 m 20'0"		7.5 m 25'0"		At Max. Reach	
		Front	Side	Front	Side	Front	Side	Front	Side	Front	Side
2250 mm	kg	7500	4650	3850	2600	2550	1750	—	—	2200*	1650
7'5"	lb	16,050	10,000	8250	5550	5450	3750	—	—	4800*	3550
2800 mm	kg	7500*	4650	3850	2600	2500	1700	—	—	1700*	1400
9'2"	lb	16,100*	10,000	8250	5500	5350	3650	—	—	3700*	3100

311F L RR ● 500 mm (20") Track Shoes ● Standard Counterweight
● Reach Boom ● No Bucket ● Blade Down

Stick		3 m 9'10"		4.5 m 15'0"		6 m 20'0"		7.5 m 25'0"		At Max. Reach	
		Front	Side	Front	Side	Front	Side	Front	Side	Front	Side
2250 mm	kg	7750*	5550	4950*	3050	3750*	2050	—	—	2200*	1900
7'5"	lb	16,800*	11,950	10,750*	6550	8050*	4400	—	—	4800*	4200
2800 mm	kg	7500*	5550	4750*	3050	3600*	2000	—	—	1700*	1650
9'2"	lb	16,150*	11,950	10,300*	6500	7800*	4350	—	—	3700*	3650

North America, Europe, Australia, New Zealand and Polynesia

311F L RR ● 500 mm (20") Track Shoes ● Heavy Duty Counterweight
● Reach Boom ● No Bucket

Stick		3 m 9'10"		4.5 m 15'0"		6 m 20'0"		7.5 m 25'0"		At Max. Reach	
		Front	Side	Front	Side	Front	Side	Front	Side	Front	Side
2250 mm	kg	7750*	4950	4050	2750	2650	1850	—	—	2200*	1750
7'5"	lb	16,800*	10,650	8700	5900	5750	4000	—	—	4800*	3800
2800 mm	kg	7500*	4950	4050	2750	2650	1850	—	—	1700*	1500
9'2"	lb	16,150*	10,650	8700	5900	5650	3900	—	—	3700*	3300

311F L RR ● 500 mm (20") Track Shoes ● Heavy Duty Counterweight
● Reach Boom ● No Bucket ● Blade Down

Stick		3 m 9'10"		4.5 m 15'0"		6 m 20'0"		7.5 m 25'0"		At Max. Reach	
		Front	Side	Front	Side	Front	Side	Front	Side	Front	Side
2250 mm	kg	7750*	5900	4950*	3250	3750*	2150	—	—	2200*	2000
7'5"	lb	16,800*	12,600	10,750*	6950	8050*	4650	—	—	4800*	4450
2800 mm	kg	7500*	5900	4750*	3200	3600*	2150	—	—	1700*	1700
9'2"	lb	16,150*	12,600	10,300*	6900	7800*	4600	—	—	3700*	3700

*Load limited by hydraulic capacity rather than tipping.

Asia Pacific

312D2 ● 500 mm (20") Track Shoes ● Reach Boom ● No Bucket

Stick		3 m 9'10"		4.5 m 15'0"		6 m 20'0"		7.5 m 25'0"		At Max. Reach	
		Front	Side	Front	Side	Front	Side	Front	Side	Front	Side
2500 mm	kg	6900*	5700	4550	3200	3000	2150	—	—	2450	1750
8'2"	lb	15,900*	12,200	9800	6850	6450	4600	—	—	5400	3850
3000 mm	kg	7850*	5700	4550	3150	3000	2100	—	—	2200	1600
9'10"	lb	18,150	12,200	9750	6800	6400	4550	—	—	4850	3450

312D2 ● 500 mm (20") Track Shoes ● Reach Boom ● No Bucket ● Blade Down

Stick		3 m 9'10"		4.5 m 15'0"		6 m 20'0"		7.5 m 25'0"		At Max. Reach	
		Front	Side	Front	Side	Front	Side	Front	Side	Front	Side
2500 mm	kg	6900*	6650	6000*	3650	4500*	2450	—	—	2600*	2050
8'2"	lb	15,900*	14,250	13,000*	7850	9750*	5300	—	—	5650*	4450
3000 mm	kg	7850*	6650	5750*	3650	4350*	2450	—	—	2300*	1850
9'10"	lb	18,150*	14,200	12,450*	7800	9400*	5250	—	—	5000*	4000

China

312D2 GC ● 500 mm (20") Track Shoes ● Reach Boom ● No Bucket

Stick		3 m 9'10"		4.5 m 15'0"		6 m 20'0"		7.5 m 25'0"		At Max. Reach	
		Front	Side	Front	Side	Front	Side	Front	Side	Front	Side
2500 mm	kg	6900*	5300	4300	2950	2850	2000	—	—	2300	1650
8'2"	lb	15,900*	11,350	9200	6350	6050	4250	—	—	5050	3600

Middle East, Africa, CIS, Asia Pacific, South America

312D2 L ● 500 mm (20") Track Shoes ● Reach Boom ● No Bucket

Stick		3 m 9'10"		4.5 m 15'0"		6 m 20'0"		7.5 m 25'0"		At Max. Reach	
		Front	Side	Front	Side	Front	Side	Front	Side	Front	Side
2500 mm	kg	6900*	5800	5300	3250	3450	2200	—	—	2600*	1800
8'2"	lb	15,900*	12,450	11,300	6950	7400	4700	—	—	5650	3950
3000 mm	kg	7850*	5800	5250	3250	3400	2150	—	—	2300*	1600
9'10"	lb	18,150*	12,450	11,300	6950	7350	4650	—	—	5000*	3550

312D2 L ● 500 mm (20") Track Shoes ● Reach Boom ● No Bucket ● Blade Down

Stick		3 m 9'10"		4.5 m 15'0"		6 m 20'0"		7.5 m 25'0"		At Max. Reach	
		Front	Side	Front	Side	Front	Side	Front	Side	Front	Side
2500 mm	kg	6900*	6800	6000*	3750	4500*	2500	—	—	2600*	2050
8'2"	lb	15,900*	14,550	13,000*	8000	9750*	5400	—	—	5650*	4550
3000 mm	kg	7850*	6800	5750*	3700	4350*	2500	—	—	2300*	1850
9'10"	lb	18,150*	14,550	12,450*	8000	9400*	5350	—	—	5000*	4100

*Load limited by hydraulic capacity rather than tipping.

Europe, Australia, New Zealand and Polynesia, Japan

312E ● 500 mm (20") Track Shoes ● Reach Boom ● No Bucket

Stick		3 m 9'10"		4.5 m 15'0"		6 m 20'0"		7.5 m 25'0"		At Max. Reach	
		Front	Side	Front	Side	Front	Side	Front	Side	Front	Side
2500 mm	kg	6900*	5750	4600	3200	3050	2200	—	—	2500	1800
8'2"	lb	15,950*	12,400	9900	6950	6550	4700	—	—	5500	3950
2800 mm	kg	7500*	5750	4600	3200	3050	2150	—	—	2350	1700
9'2"	lb	17,350*	12,350	9900	6900	6500	4650	—	—	5150	3700
3000 mm	kg	7850*	5750	4600	3200	3000	2150	—	—	2250	1600
9'10"	lb	18,150*	12,350	9900	6900	6500	4600	—	—	4950	3500

312E ● 500 mm (20") Track Shoes ● Reach Boom ● No Bucket ● Blade Down

Stick		3 m 9'10"		4.5 m 15'0"		6 m 20'0"		7.5 m 25'0"		At Max. Reach	
		Front	Side	Front	Side	Front	Side	Front	Side	Front	Side
2500 mm	kg	6900*	6700	6000*	3700	4500*	2500	—	—	2600*	2050
8'2"	lb	15,950*	14,400	12,950*	7950	9700*	5350	—	—	5650*	4500
2800 mm	kg	7500*	6700	5850*	3700	4400*	2550	—	—	2500*	1950
9'2"	lb	17,350*	14,350	12,650*	7900	9500*	5300	—	—	5450*	4250
3000 mm	kg	7850*	6700	5750*	3650	4300*	2450	—	—	2300*	1850
9'10"	lb	18,150*	14,350	12,450*	7900	9350*	5300	—	—	5000*	4050

North America, Europe, Australia, New Zealand and Polynesia

312E L ● 500 mm (20") Track Shoes ● Reach Boom ● No Bucket

Stick		3 m 9'10"		4.5 m 15'0"		6 m 20'0"		7.5 m 25'0"		At Max. Reach	
		Front	Side	Front	Side	Front	Side	Front	Side	Front	Side
2500 mm	kg	6900*	5900	5400	3300	3500	2250	—	—	2600*	1850
8'2"	lb	15,950	12,700	11,550	7100	7550	4800	—	—	5650	4050
2800 mm	kg	7500*	5900	5350	3300	3500	2200	—	—	2500*	1750
9'2"	lb	17,350	12,650	11,500	7050	7500	4750	—	—	5450	3800
3000 mm	kg	7850*	5900	5350	3300	3500	2200	—	—	2300*	1650
9'10"	lb	18,150	12,650	11,500	7050	7450	4750	—	—	5000	3600

312E L ● 600 mm (24") Track Shoes ● Reach Boom ● No Bucket

Stick		3 m 9'10"		4.5 m 15'0"		6 m 20'0"		7.5 m 25'0"		At Max. Reach	
		Front	Side	Front	Side	Front	Side	Front	Side	Front	Side
2500 mm	kg	6900*	6000	5450	3350	3550	2250	—	—	2600*	1850
8'2"	lb	15,950	12,900	11,750	7200	7650	4900	—	—	5650	4100
2800 mm	kg	7500*	6000	5450	3350	3550	2250	—	—	2500*	1750
9'2"	lb	17,350	12,850	11,700	7200	7650	4850	—	—	5450	3850
3000 mm	kg	7850*	6000	5450	3350	3550	2250	—	—	2300*	1700
9'10"	lb	18,150	12,850	11,700	7150	7600	4800	—	—	5000	3700

312E L ● 700 mm (28") Track Shoes ● Reach Boom ● No Bucket

Stick		3 m 9'10"		4.5 m 15'0"		6 m 20'0"		7.5 m 25'0"		At Max. Reach	
		Front	Side	Front	Side	Front	Side	Front	Side	Front	Side
2500 mm	kg	6900*	6100	5550	3400	3650	2300	—	—	2600*	1900
8'2"	lb	15,950	13,150	11,950	7350	7800	4950	—	—	5650	4200
2800 mm	kg	7500*	6100	5550	3400	3600	2300	—	—	2500*	1800
9'2"	lb	17,350	13,100	11,950	7300	7800	4950	—	—	5450	3950
3000 mm	kg	7850*	6100	5550	3400	3600	2300	—	—	2300*	1700
9'10"	lb	18,150	13,100	11,950	7300	7750	4900	—	—	5000	3750

*Load limited by hydraulic capacity rather than tipping.

North America, Europe, Australia, New Zealand and Polynesia

312E L ● 500 mm (20") Track Shoes ● Reach Boom ● No Bucket ● Blade Down

Stick		3 m 9'10"		4.5 m 15'0"		6 m 20'0"		7.5 m 25'0"		At Max. Reach	
		Front	Side	Front	Side	Front	Side	Front	Side	Front	Side
2500 mm	kg	6900*	6900*	6000*	3800	4500*	2550	—	—	2600*	2100
8'2"	lb	15,950	14,800	13,000	8150	9750	5500	—	—	5650	4650
2800 mm	kg	7500*	6900	5900*	3800	4400*	2550	—	—	2500*	2000
9'2"	lb	17,350	14,800	12,700	8150	9550	5450	—	—	5450	4350
3000 mm	kg	7850*	6900	5750*	3800	4350*	2550	—	—	2300*	1900
9'10"	lb	18,150	14,800	12,500	8100	9400	5450	—	—	5000	4150

312E L ● 600 mm (24") Track Shoes ● Reach Boom ● No Bucket ● Blade Down

Stick		3 m 9'10"		4.5 m 15'0"		6 m 20'0"		7.5 m 25'0"		At Max. Reach	
		Front	Side	Front	Side	Front	Side	Front	Side	Front	Side
2500 mm	kg	6900	6900	6000	3950	4500	2650	—	—	2600	2200
8'2"	lb	15,950	15,450	13,000	8500	9750	5700	—	—	5650	4800
2800 mm	kg	7500*	7200	5900*	3950	4400*	2650	—	—	2500*	2050
9'2"	lb	17,350	15,450	12,700	8450	9550	5650	—	—	5450	4500
3000 mm	kg	7850*	7200	5750*	3950	4350*	2650	—	—	2300*	2000
9'10"	lb	18,150	15,450	12,500	8450	9400	5650	—	—	5000	4350

7

312E L ● 700 mm (28") Track Shoes ● Reach Boom ● No Bucket ● Blade Down

Stick		3 m 9'10"		4.5 m 15'0"		6 m 20'0"		7.5 m 25'0"		At Max. Reach	
		Front	Side	Front	Side	Front	Side	Front	Side	Front	Side
2500 mm	kg	6900*	6900*	6000*	4100	4500*	2750	—	—	2600*	2300
8'2"	lb	15,950	15,950	13,000	8850	9750	5950	—	—	5650	5000
2800 mm	kg	7500*	7500*	5900*	4100	4400*	2750	—	—	2500*	2150
9'2"	lb	16,500	16,500	12,700	8800	9550	5900	—	—	5450	4700
3000 mm	kg	7850*	7550	5750*	4100	4350*	2750	—	—	2300*	2050
9'10"	lb	18,150	16,150	12,500	8800	9400	5900	—	—	5000	4500

China, Asia Pacific

313D2 ● 500 mm (20") Track Shoes ● HD Boom ● No Bucket

Stick		3 m 9'10"		4.5 m 15'0"		6 m 20'0"		7.5 m 25'0"		At Max. Reach	
		Front	Side	Front	Side	Front	Side	Front	Side	Front	Side
2500 mm	kg	6850*	5600	4550	3100	3000	2100	—	—	2450	1700
8'2"	lb	15,850*	12,050	9750	6700	6400	4500	—	—	5350	3750

Asia Pacific

313D2 LGP ● 960 mm (38") Track Shoes ● HD Boom ● No Bucket

Stick		3 m 9'10"		4.5 m 15'0"		6 m 20'0"		7.5 m 25'0"		At Max. Reach	
		Front	Side	Front	Side	Front	Side	Front	Side	Front	Side
2500 mm	kg	7500*	6450	6100	3600	4000	2450	—	—	2750*	2050
8'2"	lb	17,250*	13,850	13,100	7700	8600	5250	—	—	6100*	4550
3000 mm	kg	8050*	6500	6000*	3600	4000	2450	—	—	2500*	1900
9'10"	lb	18,500*	13,950	12,950*	7800	8650	5300	—	—	5450*	4200

*Load limited by hydraulic capacity rather than tipping.

North America, Europe, Turkey

313F L GC ● 500 mm (20") Track Shoes ● HD Counterweight ● Reach Boom ● No Bucket

Stick		3 m 9'10"		4.5 m 15'0"		6 m 20'0"		7.5 m 25'0"		At Max. Reach	
		Front	Side	Front	Side	Front	Side	Front	Side	Front	Side
2500 mm	kg	6900*	5800	5300	3250	3450	2200	—	—	2600*	1800
8'2"	lb	15,900*	12,500	11,350	6950	7400	4700	—	—	5650*	3950
3000 mm	kg	7850*	5800	5300	3250	3400	2150	—	—	2300*	1600
9'10"	lb	18,150*	12,450	11,300	6950	7350	4650	—	—	5000*	3550

313F L GC ● 700 mm (28") Track Shoes ● HD Counterweight ● Reach Boom ● No Bucket

Stick		3 m 9'10"		4.5 m 15'0"		6 m 20'0"		7.5 m 25'0"		At Max. Reach	
		Front	Side	Front	Side	Front	Side	Front	Side	Front	Side
2500 mm	kg	6900*	6050	5500	3350	3600	2300	—	—	2600*	1900
8'2"	lb	15,900*	12,950	11,800	7250	7700	4900	—	—	5650*	4100
3000 mm	kg	7850*	6000	5450	3350	3550	2250	—	—	2300*	1700
9'10"	lb	18,150*	12,900	11,750	7200	7650	4850	—	—	5000*	3700

313F L GC ● 500 mm (20") Track Shoes ● HD Counterweight ● Reach Boom ● No Bucket ● Blade Down

Stick		3 m 9'10"		4.5 m 15'0"		6 m 20'0"		7.5 m 25'0"		At Max. Reach	
		Front	Side	Front	Side	Front	Side	Front	Side	Front	Side
2500 mm	kg	6900*	6800	6000	3750	4500	2550	—	—	2600*	2100
8'2"	lb	15,900*	14,600	13,000*	8050	9700*	5400	—	—	5650*	4550
3000 mm	kg	7850*	6800	5750*	3750	4300*	2500	—	—	2300*	1850
9'10"	lb	18,150*	14,600	12,450*	8000	9350*	5350	—	—	5000*	4100

313F L GC ● 700 mm (28") Track Shoes ● HD Counterweight ● Reach Boom ● No Bucket ● Blade Down

Stick		3 m 9'10"		4.5 m 15'0"		6 m 20'0"		7.5 m 25'0"		At Max. Reach	
		Front	Side	Front	Side	Front	Side	Front	Side	Front	Side
2500 mm	kg	6900*	6900*	6000*	4050	4500*	2750	—	—	2600*	2250
8'2"	lb	15,900*	15,900*	13,000*	8700	9700*	5850	—	—	5650*	4950
3000 mm	kg	7850*	7450	5750*	4050	4300*	2700	—	—	2300*	2050
9'10"	lb	18,150*	15,950	12,450*	8650	9350*	5800	—	—	5000*	4450

Australia, New Zealand and Polynesia, Japan

314E CR ● 500 mm (20") Track Shoes ● Reach Boom ● No Bucket

Stick		3 m 9'10"		4.5 m 15'0"		6 m 20'0"		7.5 m 25'0"		At Max. Reach	
		Front	Side	Front	Side	Front	Side	Front	Side	Front	Side
2500 mm	kg	6550*	4650	3950	2600	2600	1750	—	—	2100	1400
8'2"	lb	15,100*	10,000	8500	5600	5600	3750	—	—	4600	3100
3000 mm	kg	7350*	4650	3950	2600	2600	1700	—	—	1900	1250
9'10"	lb	16,400	9950	8450	5550	5500	3700	—	—	4150	2750

*Load limited by hydraulic capacity rather than tipping.

North America, Europe, Australia, New Zealand and Polynesia, Japan

314E LCR ● 500 mm (20") Track Shoes ● Reach Boom ● No Bucket

Stick		3 m 9'10"		4.5 m 15'0"		6 m 20'0"		7.5 m 25'0"		At Max. Reach	
		Front	Side	Front	Side	Front	Side	Front	Side	Front	Side
2500 mm	kg	6550*	5600	5300	3150	3450	2100			2600*	1750
8'2"	lb	15,100*	12,000	11,400	6700	7450	4550	—	—	5700*	3750
3000 mm	kg	7350*	5600	5300	3100	3450	2100			2300*	1550
9'10"	lb	16,950*	11,950	11,350	6650	7400	4450	—	—	5050*	3400

314E LCR ● 500 mm (20") Track Shoes ● Reach Boom ● No Bucket ● Blade Down

Stick		3 m 9'10"		4.5 m 15'0"		6 m 20'0"		7.5 m 25'0"		At Max. Reach	
		Front	Side	Front	Side	Front	Side	Front	Side	Front	Side
2500 mm	kg	6550*	6550	5700*	3650	4150*	2450			2600*	2000
8'2"	lb	15,100*	14,250	12,300*	7850	8950*	5300	—	—	5700*	4400
3000 mm	kg	7350*	6600	5600*	3650	4100*	2450			2300*	1800
9'10"	lb	16,950*	14,200	12,100*	7800	8850*	5200	—	—	5050*	3950

316E L ● 500 mm (20") Track Shoes ● Reach Boom ● No Bucket

Stick		3 m 9'10"		4.5 m 15'0"		6 m 20'0"		7.5 m 25'0"		At Max. Reach	
		Front	Side	Front	Side	Front	Side	Front	Side	Front	Side
2250 mm	kg	5600*	5600*	7300	4250	4750	2900			3800	2350
7'5"	lb	12,950*	12,950*	15,700	9100	10,200	6200	—	—	8350	5100
2600 mm	kg	6250*	6250*	7300	4250	4750	2900			3400*	2200
8'6"	lb	14,400*	14,400*	15,700	9100	10,200	6200	—	—	7450*	4750
2900 mm	kg	7050*	7050*	7300	4200	4750	2850	3450	2100	3200*	2050
9'6"	lb	16,150*	16,150*	15,650	9050	10,150	6100	7450	4500	7050*	4500
3100 mm	kg	6650*	6650*	7300	4200	4700	2850	3400	2100	2800*	1950
10'2"	lb	15,300*	15,300*	15,650	9050	10,150	6100	7350	4450	6150*	4250

316E L ● 600 mm (24") Track Shoes ● Reach Boom ● No Bucket

Stick		3 m 9'10"		4.5 m 15'0"		6 m 20'0"		7.5 m 25'0"		At Max. Reach	
		Front	Side	Front	Side	Front	Side	Front	Side	Front	Side
2250 mm	kg	5600*	5600*	7400	4300	4800	2900			3850	2350
7'5"	lb	12,950*	12,950*	15,850	9200	10,350	6250	—	—	8450	5150
2600 mm	kg	6250*	6250*	7400	4300	4800	2900			3400*	2200
8'6"	lb	14,400*	14,400*	15,900	9250	10,350	6250	—	—	7450*	4850
2900 mm	kg	7050*	7050*	7400	4250	4800	2900	3500	2100	3200*	2100
9'6"	lb	16,150*	16,150*	15,850	9150	10,300	6200	7700	4600	7050*	4600
3100 mm	kg	6650*	6650*	7400	4250	4800	2900	3450	2100	2800*	1950
10'2"	lb	15,300*	15,300*	15,850	9200	10,250	6200	7450	4500	6150*	4300

316E L ● 700 mm (28") Track Shoes ● Reach Boom ● No Bucket

Stick		3 m 9'10"		4.5 m 15'0"		6 m 20'0"		7.5 m 25'0"		At Max. Reach	
		Front	Side	Front	Side	Front	Side	Front	Side	Front	Side
2250 mm	kg	5600*	5600*	7500	4350	4900	2950			3900	2400
7'5"	lb	12,950*	12,950*	16,100	9350	10,500	6350	—	—	8550	5250
2600 mm	kg	6250*	6250*	7500	4350	4900	2950			3400*	2250
8'6"	lb	14,400*	14,400*	16,100	9350	10,500	6350	—	—	7450*	4900
2900 mm	kg	7050*	7050*	7500	4300	4850	2950	3500	2150	3200*	2100
9'6"	lb	16,150*	16,150*	16,050	9300	10,450	6300	7700	4750	7050*	4650
3100 mm	kg	6650*	6650*	7500	4350	4850	2900	3500	2150	2800*	2000
10'2"	lb	15,300*	15,300*	16,100	9300	10,400	6250	7500	4600	6150*	4400

*Load limited by hydraulic capacity rather than tipping.

Middle East, Africa, CIS, South America, Asia Pacific

318D2 L ● 600 mm (24") Track Shoes ● Reach Boom ● No Bucket

Stick		3 m 9'10"		4.5 m 15'0"		6 m 20'0"		7.5 m 25'0"		At Max. Reach	
		Front	Side	Front	Side	Front	Side	Front	Side	Front	Side
2600 mm	kg	6250*	6250*	7450	4400	4850	3000			3400*	2250
8'6"	lb	14,400*	14,400*	16,000	9500	10,400	6450	—	—	7450*	5000
2900 mm	kg	7050*	7050*	7450	4400	4800	2950	3500	2200	3200*	2150
9'6"	lb	16,150*	16,150*	15,950	9450	10,350	6400	7700	4750	7050*	4700

China

318D2 L ● 600 mm (24") Track Shoes ● HD Boom ● No Bucket

Stick		3 m 9'10"		4.5 m 15'0"		6 m 20'0"		7.5 m 25'0"		At Max. Reach	
		Front	Side	Front	Side	Front	Side	Front	Side	Front	Side
2600 mm	kg	6250*	6250*	7350	4250	4750	2900	—	—	3350*	2150
8'6"	lb	14,350*	14,350*	15,700	9150	10,200	6200	—	—	7400*	4750
2900 mm	kg	7050*	7050*	7400	4350	4800	2950	3450	2150	3200*	2100
9'6"	lb	16,150*	16,150*	15,850	9300	10,300	6300	7450	4700	7050*	4650

North America, Australia, New Zealand and Polynesia, Asia Pacific

318E L ● 500 mm (20") Track Shoes ● Reach Boom ● No Bucket

Stick		3 m 9'10"		4.5 m 15'0"		6 m 20'0"		7.5 m 25'0"		At Max. Reach	
		Front	Side	Front	Side	Front	Side	Front	Side	Front	Side
2250 mm	kg	6050*	6050*	7950*	4650	5400	3200	—	—	4050*	2550
7'5"	lb	14,000*	14,000*	17,200*	10,050	11,650	6850	—	—	8850*	5650
2600 mm	kg	6750*	6750*	7850*	4700	5400	3200	—	—	3350*	2400
8'6"	lb	15,550*	15,550*	16,950*	10,050	11,650	6850	—	—	7400*	5300
2900 mm	kg	7600*	7600*	7700*	4650	5400	3150	3700*	2350*	3200*	2300
9'6"	lb	17,450*	17,450*	16,600*	10,050	11,600	6800	7900*	5150*	7000*	5050
3100 mm	kg	7200*	7200*	7550*	4650	5400	3150	3900	2300	2800*	2150
10'2"	lb	16,550*	16,550*	16,350*	10,050	11,600	6750	8350	4950	6100*	4750

318E L ● 600 mm (24") Track Shoes ● Reach Boom ● No Bucket

Stick		3 m 9'10"		4.5 m 15'0"		6 m 20'0"		7.5 m 25'0"		At Max. Reach	
		Front	Side	Front	Side	Front	Side	Front	Side	Front	Side
2250 mm	kg	6050*	6050*	7950*	4700	5500	3200	—	—	4050*	2600
7'5"	lb	14,000*	14,000*	17,200*	10,150	11,800	6900	—	—	8850*	5700
2600 mm	kg	6750*	6750*	7850*	4750	5500	3200	—	—	3350*	2450
8'6"	lb	15,550*	15,550*	16,950*	10,200	11,800	6900	—	—	7400*	5350
2900 mm	kg	7600*	7600*	7700*	4700	5450	3200	3700*	2350*	3200*	2300
9'6"	lb	17,450*	17,450*	16,600*	10,150	11,750	6850	7900*	5150*	7000*	5100
3100 mm	kg	7200*	7200*	7550*	4700	5450	3200	3950	2350	2800*	2200
10'2"	lb	16,550*	16,550*	16,350*	10,150	11,700	6850	8450	5000	6100*	4800

318E L ● 700 mm (28") Track Shoes ● Reach Boom ● No Bucket

Stick		3 m 9'10"		4.5 m 15'0"		6 m 20'0"		7.5 m 25'0"		At Max. Reach	
		Front	Side	Front	Side	Front	Side	Front	Side	Front	Side
2250 mm	kg	6050*	6050*	7950*	4800	5550	3250	—	—	4050*	2650
7'5"	lb	14,000*	14,000*	17,200*	10,300	11,950	7000	—	—	8850*	5800
2600 mm	kg	6750*	6750*	7850*	4800	5550	3250	—	—	3350*	2450
8'6"	lb	15,550*	15,550*	16,950*	10,300	11,950	7000	—	—	7400*	5400
2900 mm	kg	7600*	7600*	7700*	4800	5550	3250	3700*	2400	3200*	2350
9'6"	lb	17,450*	17,450*	16,600*	10,300	11,900	6950	7900*	5250	7000*	5150
3100 mm	kg	7200*	7200*	7550*	4800	5550	3250	4000	2350	2800*	2200
10'2"	lb	16,550*	16,550*	16,350*	10,250	11,850	6950	8600	5050	6100*	4850

*Load limited by hydraulic capacity rather than tipping.

M313D/M315D2 ● Rear Dozer Up

Stick		3 m 9'10"		4.5 m 15'0"		6 m 20'0"		7.5 m 25'0"		At Max. Reach	
		Front	Side	Front	Side	Front	Side	Front	Side	Front	Side
2000 mm	kg	—	—	4900	2900	3200	1900	—	—	2300*	1400
6'7"	lb	—	—	10,805	6395	7056	4190	—	—	5071*	3087
2300 mm	kg	4300*	4300*	4900	2900	3200	1900	—	—	2100*	1300
7'7"	lb	9482*	9482*	10,805	6395	7056	4190	—	—	4631*	2867
2600 mm	kg	4600*	4600*	4800	2900	3100	1900	2300	1400	1800*	1200
8'6"	lb	10,143*	10,143*	10,573	6395	6836	4190	5072	3087	3969*	2646

M313D/M315D2 ● Rear Dozer Down

Stick		3 m 9'10"		4.5 m 15'0"		6 m 20'0"		7.5 m 25'0"		At Max. Reach	
		Front	Side	Front	Side	Front	Side	Front	Side	Front	Side
2000 mm	kg	—	—	6700*	3400	4800*	2200	—	—	2300*	1700
6'7"	lb	—	—	14,774*	7497	10,584*	4851	—	—	5071*	3749
2300 mm	kg	4300*	4300*	6700*	3400	4800*	2200	—	—	2100*	1600
7'7"	lb	9482*	9482*	14,774*	7497	10,584*	4851	—	—	4631*	3528
2600 mm	kg	4600*	4600*	6700*	3400	4800*	2200	2600*	1600	1800*	1500
8'6"	lb	10,143*	10,143*	14,774*	7497	10,584*	4851	5733*	3528	3969*	3308

7

M313D/M315D2 ● Rear Stabilizer Down

Stick		3 m 9'10"		4.5 m 15'0"		6 m 20'0"		7.5 m 25'0"		At Max. Reach	
		Front	Side	Front	Side	Front	Side	Front	Side	Front	Side
2000 mm	kg	—	—	6700*	4200	4500	2800	—	—	2300*	2000
6'7"	lb	—	—	14,774*	9261	9923	6174	—	—	5071*	4410
2300 mm	kg	4300*	4300*	6700*	4200	4500	2800	—	—	2100*	1900
7'7"	lb	9482*	9482*	14,774*	9261	9923	6174	—	—	4631*	4190
2600 mm	kg	4600*	4600*	6700*	4200	4500	2800	2600*	2000	1800*	1800*
8'6"	lb	10,143*	10,143*	14,774*	9261	9923	6174	5733*	4410	3969*	3969*

M313D/M315D2 ● 4-Point Stabilizers Down

Stick		3 m 9'10"		4.5 m 15'0"		6 m 20'0"		7.5 m 25'0"		At Max. Reach	
		Front	Side	Front	Side	Front	Side	Front	Side	Front	Side
2000 mm	kg	—	—	6700*	6600	4800*	4200	—	—	2300*	2300*
6'7"	lb	—	—	14,774*	14,553	10,584*	9261	—	—	5071*	5071*
2300 mm	kg	4300*	4300*	6700*	6600	4800*	4200	—	—	2100*	2100*
7'7"	lb	9482*	9482*	14,774*	14,553	10,584*	9261	—	—	4631*	4631*
2600 mm	kg	4600*	4600*	6700*	6600	4800*	4200	2600*	2600*	1800*	1800*
8'6"	lb	10,143*	10,143*	14,774*	14,553	10,584*	9261	5733*	5733*	3969*	3969*

M313D/M315D2 ● Dozer and Stabilizer Down

Stick		3 m 9'10"		4.5 m 15'0"		6 m 20'0"		7.5 m 25'0"		At Max. Reach	
		Front	Side	Front	Side	Front	Side	Front	Side	Front	Side
2000 mm	kg	—	—	6700*	5300	4800*	3400	—	—	2300*	2300*
6'7"	lb	—	—	14,774*	11,687	10,584*	7497	—	—	5071*	5071*
2300 mm	kg	4300*	4300*	6700*	5300	4800*	3400	—	—	2100*	2100*
7'7"	lb	9482*	9482*	14,774*	11,687	10,584*	7497	—	—	4631*	4631*
2600 mm	kg	4600*	4600*	6700*	5300	4800*	3400	2600*	2500	1800*	1800*
8'6"	lb	10,143*	10,143*	14,774*	11,687	10,584*	7497	5733*	5513	3969*	3969*

*Load limited by hydraulic capacity rather than tipping.

M313D/M315D2 ● Rear Dozer Up

Stick		3 m 9'10"		4.5 m 15'0"		6 m 20'0"		7.5 m 25'0"		At Max. Reach	
		Front	Side	Front	Side	Front	Side	Front	Side	Front	Side
2000 mm	kg	10 200	5900	5300	3300	3300	2000	—	—	2200	1300
6'7"	lb	22,491	13,010	11,687	7277	7277	4410	—	—	4851	2867
2300 mm	kg	10 000*	6000	5300	3300	3300	2100	2300	1300	2100	1200
7'7"	lb	22,050*	13,230	11,687	7277	7277	4631	5072	2867	4631	2646
2600 mm	kg	9800*	6000	5200*	3300	3400	2100	2300	1300	1900*	1100
8'6"	lb	21,609*	13,230	11,466*	7277	7497	4631	5072	2867	4189*	2426

M313D/M315D2 ● Rear Dozer Down

Stick		3 m 9'10"		4.5 m 15'0"		6 m 20'0"		7.5 m 25'0"		At Max. Reach	
		Front	Side	Front	Side	Front	Side	Front	Side	Front	Side
2000 mm	kg	10 200*	7000	6600*	3800	4800*	2400	—	—	2500*	1500
6'7"	lb	22,491*	15,435	14,553*	8379	10,584*	5292	—	—	5513*	3308
2300 mm	kg	10 000*	7100	6600*	3800	4800*	2400	3000*	1600	2200*	1400
7'7"	lb	22,050*	15,656	14,553*	8379	10,584*	5292	6615*	3528	4851*	3087
2600 mm	kg	9800*	7100*	6500*	3800	4700*	2400	3500*	1600	1900*	1300
8'6"	lb	21,609*	15,656*	14,333*	8379	10,364*	5292	7718*	3528	4189*	2867

M313D/M315D2 ● Rear Stabilizer Down

Stick		3 m 9'10"		4.5 m 15'0"		6 m 20'0"		7.5 m 25'0"		At Max. Reach	
		Front	Side	Front	Side	Front	Side	Front	Side	Front	Side
2000 mm	kg	10 200*	8900*	6600*	4700	4700	2900	—	—	2500*	1900*
6'7"	lb	22,491*	19,625*	14,553*	10,364	10,364	6395	—	—	5513*	4189*
2300 mm	kg	10 000*	8900	6600*	4700	4600*	3300	3000*	2000	2200*	1800
7'7"	lb	22,050*	19,625	14,553*	10,364	10,143*	7277	6615*	4410	4851*	3969
2600 mm	kg	9800*	8800	6500*	4700	4600*	3000	3200	2000	1900*	1700
8'6"	lb	21,609*	19,404	14,333*	10,364	10,143*	6615	7056	4410	4189*	3749

M313D/M315D2 ● 4-Point Stabilizers Down

Stick		3 m 9'10"		4.5 m 15'0"		6 m 20'0"		7.5 m 25'0"		At Max. Reach	
		Front	Side	Front	Side	Front	Side	Front	Side	Front	Side
2000 mm	kg	10 200*	10 200*	6600*	6600*	4800*	4300	—	—	2500*	2500*
6'7"	lb	22,491*	22,491*	14,553*	14,553*	10,584*	9482	—	—	5513*	5513*
2300 mm	kg	10 000*	10 000*	6600*	6600*	4800*	4400	3000*	3000	2200*	2200*
7'7"	lb	22,050*	22,050*	14,553*	14,553*	10,584*	9702	6615*	6615	4851*	4851*
2600 mm	kg	9800*	9800*	6500*	6500*	4700*	4400	3500*	3000	1900*	1900*
8'6"	lb	21,609*	21,609*	14,333*	14,333*	10,364*	9702	7718*	6615	4189*	4189*

M313D/M315D2 ● Dozer and Stabilizer Down

Stick		3 m 9'10"		4.5 m 15'0"		6 m 20'0"		7.5 m 25'0"		At Max. Reach	
		Front	Side	Front	Side	Front	Side	Front	Side	Front	Side
2000 mm	kg	10 200*	10 200*	6600*	5700*	4800*	3600	—	—	2500*	2400
6'7"	lb	22,491*	22,491	14,553*	12,569*	10,584*	7938	—	—	5513*	5292
2300 mm	kg	10 000*	10 000*	6600*	5700	4800*	3600	3000*	2500	2200*	2200*
7'7"	lb	22,050*	22,050*	14,553*	12,569	10,584*	7938	6615*	5513	4851*	4851*
2600 mm	kg	9800*	9800*	6500*	5600	4700*	3600	3500*	2500	1900*	1900*
8'6"	lb	21,609*	21,609*	14,333*	12,348	10,364*	7938	7718*	5513	4189*	4189*

*Load limited by hydraulic capacity rather than tipping.

M315D/M317D2 ● Rear Dozer Up

Stick		3 m 9'10"		4.5 m 15'0"		6 m 20'0"		7.5 m 25'0"		At Max. Reach	
		Front	Side	Front	Side	Front	Side	Front	Side	Front	Side
2100 mm	kg	—	—	5700	3300	3700	2200	—	—	2500	1500
6'11"	lb	—	—	12,569	7277	8159	4851	—	—	5513	3308
2400 mm	kg	4000*	4000*	5600	3200	3700	2200	2600	1600	2400	1400
7'10"	lb	8820*	8820*	12,348	7056	8159	4851	5733	3528	5292	3087
2600 mm	kg	4200*	4200*	5700	3300	3700	2200	2600	1600	2300	1400
8'6"	lb	9261*	9261*	12,569	7277	8159	4851	5733	3528	5072	3087

M315D/M317D2 ● Rear Dozer Down

Stick		3 m 9'10"		4.5 m 15'0"		6 m 20'0"		7.5 m 25'0"		At Max. Reach	
		Front	Side	Front	Side	Front	Side	Front	Side	Front	Side
2100 mm	kg	—	—	7900*	3800	5700*	2500	—	—	2900*	1800
6'11"	lb	—	—	17,419*	8379	12,569*	5513	—	—	6395*	3969
2400 mm	kg	4000*	4000*	7900*	3800	5700*	2500	4000	1800	2600*	1700
7'10"	lb	8820*	8820*	17,419*	8379	12,569*	5513	8820	3969	5733*	3749
2600 mm	kg	4200*	4200*	7900*	3800	5700*	2500	4000	1800	2400*	1600
8'6"	lb	9261*	9261*	17,419*	8379	12,569*	5513	8820	3969	5292*	3528

7

M315D/M317D2 ● Rear Stabilizer Down

Stick		3 m 9'10"		4.5 m 15'0"		6 m 20'0"		7.5 m 25'0"		At Max. Reach	
		Front	Side	Front	Side	Front	Side	Front	Side	Front	Side
2100 mm	kg	—	—	7900*	4800	5100	3100	—	—	2900*	2200
6'11"	lb	—	—	17,419*	10,584	11,246	6836	—	—	6395*	4851
2400 mm	kg	4000*	4000*	7900*	4800	5100	3100	3600	2300	2600*	2100
7'10"	lb	8820*	8820*	17,419*	10,584	11,246	6836	7938	5072	5733*	4631
2600 mm	kg	4200*	4200*	7900*	4800	5100	3100	3600	2300	2400*	2000
8'6"	lb	9261*	9261*	17,419*	10,584	11,246	6836	7938	5072	5292*	4410

M315D/M317D2 ● 4-Point Stabilizers Down

Stick		3 m 9'10"		4.5 m 15'0"		6 m 20'0"		7.5 m 25'0"		At Max. Reach	
		Front	Side	Front	Side	Front	Side	Front	Side	Front	Side
2100 mm	kg	—	—	7900*	7300	5700*	4700	—	—	2900*	2900*
6'11"	lb	—	—	17,419*	16,097	12,569*	10,364	—	—	6395*	6395*
2400 mm	kg	4000*	4000*	7900*	7300	5700*	4600	4200*	3300	2600*	2600*
7'10"	lb	8820*	8820*	17,419*	16,097	12,569*	10,143	9261*	7277	5733*	5733*
2600 mm	kg	4200*	4200*	7900*	7300	5700*	4600	4400*	3300	2400*	2400*
8'6"	lb	9261*	9261*	17,419*	16,097	12,569*	10,143	9702*	7277	5292*	5292*

M315D/M317D2 ● Dozer and Stabilizer Down

Stick		3 m 9'10"		4.5 m 15'0"		6 m 20'0"		7.5 m 25'0"		At Max. Reach	
		Front	Side	Front	Side	Front	Side	Front	Side	Front	Side
2100 mm	kg	—	—	7900*	5900	5700*	3800	—	—	2900*	2700
6'11"	lb	—	—	17,419*	13,010	12,569*	8379	—	—	6395*	5954
2400 mm	kg	4000*	4000*	7900*	5900	5700*	3800	4200*	2800	2600*	2500
7'10"	lb	8820*	8820*	17,419*	13,010	12,569*	8379	9261*	6174	5733*	5513
2600 mm	kg	4200*	4200*	7900*	5900	5700*	3800	4400*	2800	2400*	2400*
8'6"	lb	9261*	9261*	17,419*	13,010	12,569*	8379	9702*	6174	5292*	5292*

*Load limited by hydraulic capacity rather than tipping.

M315D/M317D2 ● Rear Dozer Up

Stick		3 m 9'10"		4.5 m 15'0"		6 m 20'0"		7.5 m 25'0"		At Max. Reach	
		Front	Side	Front	Side	Front	Side	Front	Side	Front	Side
2100 mm	kg	11 800*	6600	6300	3800	3900	2400	2600	1500	2400	1400
6'11"	lb	26,019*	14,553	13,892	8379	8600	5292	5733	3308	5292	3087
2400 mm	kg	11 600*	6900	6200	3800	4000	2400	2600	1500	2300	1300
7'10"	lb	25,578*	15,215	13,671	8379	8820	5292	5733	3308	5072	2867
2600 mm	kg	11 200*	6900	6200	3800	4000	2500	2700	1600	2200	1300
8'6"	lb	24,696*	15,215	13,671	8379	8820	5513	5954	3528	4851	2867

M315D/M317D2 ● Rear Dozer Down

Stick		3 m 9'10"		4.5 m 15'0"		6 m 20'0"		7.5 m 25'0"		At Max. Reach	
		Front	Side	Front	Side	Front	Side	Front	Side	Front	Side
2100 mm	kg	11 800*	7900	7900*	4400	5700*	2700	4000*	1800	2900*	1700
6'11"	lb	26,019*	17,420	17,420*	9702	12,569*	5954	8820*	3969	6395*	3749
2400 mm	kg	11 600*	8100	7800*	4400	5600*	2800	4100	1800	2500*	1500
7'10"	lb	25,578*	17,861	17,199*	9702	12,348*	6174	9041	3969	5513*	3308
2600 mm	kg	11 200*	8200	7800*	4400	5600*	2800	4100	1800	2300*	1500
8'6"	lb	24,696*	18,081	17,199*	9702	12,348*	6174	9041	3969	5072*	3308

M315D/M317D2 ● Rear Stabilizer Down

Stick		3 m 9'10"		4.5 m 15'0"		6 m 20'0"		7.5 m 25'0"		At Max. Reach	
		Front	Side	Front	Side	Front	Side	Front	Side	Front	Side
2100 mm	kg	11 800*	10 200	7900*	5400	5400	3400	3600	2200	2900*	2100
6'11"	lb	26,019*	22,491	17,420*	11,907	11,907	7497	7938	4851	6395*	4631
2400 mm	kg	11 600*	10 100*	7800*	5400	5300	3400	3600	2300	2500*	1900
7'10"	lb	25,578*	22,271*	17,199*	11,907	11,687	7497	7938	5072	5513*	4190
2600 mm	kg	11 200*	10 100	7800*	5400	5300	3500	3700	2300	2300*	1900
8'6"	lb	24,696*	22,271	17,199*	11,907	11,687	7718	8159	5072	5072*	4190

M315D/M317D2 ● 4-Point Stabilizers Down

Stick		3 m 9'10"		4.5 m 15'0"		6 m 20'0"		7.5 m 25'0"		At Max. Reach	
		Front	Side	Front	Side	Front	Side	Front	Side	Front	Side
2100 mm	kg	11 800*	11 800*	7900*	7600	5700*	4900	4000*	3300	2900*	2900*
6'11"	lb	26,019*	26,019*	17,420*	16,758	12,569*	10,805	8820*	7277	6395*	6395*
2400 mm	kg	11 600*	11 600*	7800*	7500*	5600*	5000	4300*	3300	2500*	2500*
7'10"	lb	25,578*	25,578*	17,199*	16,538*	12,348*	11,025	9482*	7277	5513*	5513*
2600 mm	kg	11 200*	11 200*	7800*	7500	5600*	5000	4300*	3400	2300*	2300*
8'6"	lb	24,696*	24,696*	17,199*	16,538	12,348*	11,025	9482*	7497	5072*	5072*

M315D/M317D2 ● Dozer and Stabilizer Down

Stick		3 m 9'10"		4.5 m 15'0"		6 m 20'0"		7.5 m 25'0"		At Max. Reach	
		Front	Side	Front	Side	Front	Side	Front	Side	Front	Side
2100 mm	kg	11 800*	11 800*	7900*	6400	5700*	4100	4000*	2800	2900*	2500
6'11"	lb	26,019*	26,019*	17,420*	14,112	12,569*	9041	8820*	6174	6395*	5513
2400 mm	kg	11 600*	11 600*	7800*	6400*	5600*	4100	4300	2800	2500*	2400
7'10"	lb	25,578*	25,578*	17,199*	14,112*	12,348*	9041	9482	6174	5513*	5292
2600 mm	kg	11 200*	11 200*	7800*	6400	5600*	4200	4300*	2800	2300*	2300
8'6"	lb	24,696*	24,696*	17,199*	14,112	12,348*	9261	9482*	6174	5072*	5072

*Load limited by hydraulic capacity rather than tipping.

M316D ● Rear Dozer Up

Stick		3 m 9'10"		4.5 m 15'0"		6 m 20'0"		7.5 m 25'0"		At Max. Reach	
		Front	Side	Front	Side	Front	Side	Front	Side	Front	Side
2100 mm 6'11"	kg lb	—	—	6400 14,112	3700 8159	4200 9261	2500 5513	—	—	2900* 6395*	1700 3749
2400 mm 7'10"	kg lb	4000* 8820*	4000* 8820*	6400 14,112	3600 7938	4100 9041	2400 5292	3000 6615	1800 3969	2600* 5733*	1600 3528
2600 mm 8'6"	kg lb	4200* 9261*	4200* 9261*	6400 14,112	3700 8159	4200 9261	2400 5292	3000 6615	1800 3969	2400* 5292*	1600 3528

M316D ● Rear Dozer Down

Stick		3 m 9'10"		4.5 m 15'0"		6 m 20'0"		7.5 m 25'0"		At Max. Reach	
		Rear	Side	Rear	Side	Rear	Side	Rear	Side	Rear	Side
2100 mm 6'11"	kg lb	—	—	8800* 19,404*	4200 9261	6400* 14,112*	2800 6174	—	—	2900* 6395*	2000 4410
2400 mm 7'10"	kg lb	4000* 8820*	4000* 8820*	8800* 19,404*	4200 9261	6300* 13,892*	2800 6174	4100* 9041*	2100 4631	2600* 5733*	1900 4190
2600 mm 8'6"	kg lb	4200* 9261*	4200* 9261*	8800* 19,404*	4200 9261	6300* 13,892*	2800 6174	4700 10,364	2000 4410	2400* 5292*	1800 3969

M316D ● Rear Stabilizer Down

Stick		3 m 9'10"		4.5 m 15'0"		6 m 20'0"		7.5 m 25'0"		At Max. Reach	
		Rear	Side	Rear	Side	Rear	Side	Rear	Side	Rear	Side
2100 mm 6'11"	kg lb	—	—	8800* 19,404*	5300 11,687	5800 12,789	3500 7718	—	—	2900* 6395*	2400 5292
2400 mm 7'10"	kg lb	4000* 8820*	4000* 8820*	8800* 19,404*	5300 11,687	5800 12,789	3500 7718	4100* 9041*	2500 5513	2600* 5733*	2300 5072
2600 mm 8'6"	kg lb	4200* 9261*	4200* 9261*	8800* 19,404*	5300 11,687	5800 12,789	3500 7718	4100 9041	2500 5513	2400* 5292*	2200 4851

M316D ● 4-Point Stabilizers Down

Stick		3 m 9'10"		4.5 m 15'0"		6 m 20'0"		7.5 m 25'0"		At Max. Reach	
		Front	Side	Front	Side	Front	Side	Front	Side	Front	Side
2100 mm 6'11"	kg lb	—	—	8800* 19,404*	8000 17,640	6400* 14,112*	5100 11,246	—	—	2900* 6395*	2900* 6395*
2400 mm 7'10"	kg lb	4000* 8820*	4000* 8820*	8800* 19,404*	8000 17,640	6300* 13,892*	5100 11,246	4100* 9041*	3700 8159	2600* 5733*	2600* 5733*
2600 mm 8'6"	kg lb	4200* 9261*	4200* 9261*	8800* 19,404*	8000 17,640	6300* 13,892*	5100 11,246	4800* 10,584*	3700 8159	2400* 5292*	2400* 5292*

M316D ● Dozer and Stabilizer Down

Stick		3 m 9'10"		4.5 m 15'0"		6 m 20'0"		7.5 m 25'0"		At Max. Reach	
		Front	Side	Front	Side	Front	Side	Front	Side	Front	Side
2100 mm 6'11"	kg lb	—	—	8800* 19,404*	6600 14,553	6400* 14,112*	4300 9482	—	—	2900* 6395*	2900* 6395*
2400 mm 7'10"	kg lb	4000* 8820*	4000* 8820*	8800* 19,404*	6600 14,553	6300* 13,892*	4300 9482	4100* 9041*	3100 6836	2600* 5733*	2600* 5733*
2600 mm 8'6"	kg lb	4200* 9261*	4200* 9261*	8800* 19,404*	6600 14,553	6300* 13,892*	4300 9482	4800* 10,584*	3100 6836	2400* 5292*	2400* 5292*

*Load limited by hydraulic capacity rather than tipping.

M316D ● Rear Dozer Up

Stick		3 m 9'10"		4.5 m 15'0"		6 m 20'0"		7.5 m 25'0"		At Max. Reach	
		Front	Side	Front	Side	Front	Side	Front	Side	Front	Side
2100 mm	kg	12 700*	7300	7000	4200	4400	2700	3000	1700	2800	1600
6'11"	lb	28,004*	16,097	15,435	9261	9702	5954	6615	3749	6174	3528
2400 mm	kg	12 500*	7600	6900	4200	4400	2700	3000	1800	2500*	1500
7'10"	lb	27,563*	16,758	15,215	9261	9702	5954	6615	3969	5513*	3308
2600 mm	kg	12 200*	7600	6900	4200	4500	2700	3000	1800	2300*	1400
8'6"	lb	26,901*	16,758	15,215	9261	9923	5954	6615	3969	5072*	3087

M316D ● Rear Dozer Down

Stick		3 m 9'10"		4.5 m 15'0"		6 m 20'0"		7.5 m 25'0"		At Max. Reach	
		Front	Side	Front	Side	Front	Side	Front	Side	Front	Side
2100 mm	kg	12 700*	8700	8700*	4800	6300*	3100	4200*	2000	2900*	1900
6'11"	lb	28,004*	19,184	19,184*	10,584	13,892*	6836	9261*	4410	6395*	4190
2400 mm	kg	12 500*	8900	8600*	4800	6200*	3100	4700*	2000	2500*	1800
7'10"	lb	27,563*	19,625	18,963*	10,584	13,671*	6836	10,364*	4410	5513*	3969
2600 mm	kg	12 200*	9000	8600*	4800	6200*	3100	4800*	2100	2300*	1700
8'6"	lb	26,901*	19,845	18,963*	10,584	13,671*	6836	10,584*	4631	5072*	3749

M316D ● Rear Stabilizer Down

Stick		3 m 9'10"		4.5 m 15'0"		6 m 20'0"		7.5 m 25'0"		At Max. Reach	
		Front	Side	Front	Side	Front	Side	Front	Side	Front	Side
2100 mm	kg	12 700*	11 100	8700*	5900	6100	3700	4100	2500	2900*	2300
6'11"	lb	28,004*	24,476	19,184*	13,010	13,451	8159	9041	5513	6395*	5072
2400 mm	kg	12 500*	11 200	8600*	5900	6000	3800	4100	2500	2500*	2200
7'10"	lb	27,563*	24,696	18,963*	13,010	13,230	8379	9041	5513	5513*	4851
2600 mm	kg	12 200*	11 100	8600*	5900	6000	3800	4200	2500	2300*	2100
8'6"	lb	26,901*	24,476	18,963*	13,010	13,230	8379	9261	5513	5072*	4631

M316D ● 4-Point Stabilizers Down

Stick		3 m 9'10"		4.5 m 15'0"		6 m 20'0"		7.5 m 25'0"		At Max. Reach	
		Front	Side	Front	Side	Front	Side	Front	Side	Front	Side
2100 mm	kg	12 700*	12 700*	8700*	8300	6300*	5400	4200*	3700	2900*	2900*
6'11"	lb	28,004*	28,004*	19,184*	18,302	13,892*	11,907	9261*	8159	6395*	6395*
2400 mm	kg	12 500*	12 500*	8600*	8300	6200*	5400	4700*	3700	2500*	2500*
7'10"	lb	27,563*	27,563*	18,963*	18,302	13,671*	11,907	10,364*	8159	5513*	5513*
2600 mm	kg	12 200*	12 200*	8600*	8200	6200*	5500	4800*	3700	2300*	2300*
8'6"	lb	26,901*	26,901*	18,963*	18,081	13,671*	12,128	10,584*	8159	5072*	5072*

M316D ● Dozer and Stabilizer Down

Stick		3 m 9'10"		4.5 m 15'0"		6 m 20'0"		7.5 m 25'0"		At Max. Reach	
		Front	Side	Front	Side	Front	Side	Front	Side	Front	Side
2100 mm	kg	12 700*	12 700*	8700*	7200	6300*	4600	4200*	3100	2900*	2900
6'11"	lb	28,004*	28,004*	19,184*	15,876	13,892*	10,143	9261*	6836	6395*	6395
2400 mm	kg	12 500*	12 500*	8600*	7100	6200*	4600	4700*	3100	2500*	2500*
7'10"	lb	27,563*	27,563*	18,963*	15,656	13,671*	10,143	10,364*	6836	5513*	5513*
2600 mm	kg	12 200*	12 200*	8600*	7100	6200*	4600	4800*	3100	2300*	2300*
8'6"	lb	26,901*	26,901*	18,963*	15,656	13,671*	10,143	10,584*	6836	5072*	5072*

*Load limited by hydraulic capacity rather than tipping.

M318D/M320D2 ● Rear Dozer Up

Stick		3 m 9'10"		4.5 m 15'0"		6 m 20'0"		7.5 m 25'0"		At Max. Reach	
		Front	Side	Front	Side	Front	Side	Front	Side	Front	Side
2200 mm	kg	—	—	6600	3700	4300	2500	3100	1800	2800	1600
7'3"	lb	—	—	14,553	8159	9482	5513	6836	3969	6174	3528
2500 mm	kg	—	—	6700	3800	4300	2500	3100	1800	2700	1600
8'2"	lb	—	—	14,774	8379	9482	5513	6836	3969	5954	3528
2800 mm	kg	5000*	5000*	6600	3800	4300	2500	3100	1800	2500	1500
9'2"	lb	11,025*	11,025*	14,553	8379	9482	5513	6836	3969	5513	3308

M318D/M320D2 ● Rear Dozer Down

Stick		3 m 9'10"		4.5 m 15'0"		6 m 20'0"		7.5 m 25'0"		At Max. Reach	
		Front	Side	Front	Side	Front	Side	Front	Side	Front	Side
2200 mm	kg	—	—	10 200*	4300	7100	2900	5000	2100	3800*	1900
7'3"	lb	—	—	22,491*	9482	15,656	6395	11,025	4631	8379*	4190
2500 mm	kg	—	—	10 200*	4400	7100	2900	5000	2100	2900*	1800
8'2"	lb	—	—	22,491*	9702	15,656	6395	11,025	4631	6395*	3969
2800 mm	kg	5000*	5000*	10 200*	4400	7100	2900	5000	2100	2600*	1700
9'2"	lb	11,025*	11,025*	22,491*	9702	15,656	6395	11,025	4631	5733*	3749

M318D/M320D2 ● Rear Stabilizer Down

Stick		3 m 9'10"		4.5 m 15'0"		6 m 20'0"		7.5 m 25'0"		At Max. Reach	
		Front	Side	Front	Side	Front	Side	Front	Side	Front	Side
2200 mm	kg	—	—	9900	5400	6100	3600	4300	2600	3800*	2400
7'3"	lb	—	—	21,830	11,907	13,451	7938	9482	5733	8379*	5292
2500 mm	kg	—	—	10 000	5500	6200	3600	4400	2600	2900*	2200
8'2"	lb	—	—	22,050	12,128	13,671	7938	9702	5733	6395*	4851
2800 mm	kg	5000*	5000*	10 000	5500	6200	3600	4300	2600	2600*	2100
9'2"	lb	11,025*	11,025*	22,050	12,128	13,671	7938	9482	5733	5733*	4631

M318D/M320D2 ● 4-Point Stabilizers Down

Stick		3 m 9'10"		4.5 m 15'0"		6 m 20'0"		7.5 m 25'0"		At Max. Reach	
		Front	Side	Front	Side	Front	Side	Front	Side	Front	Side
2200 mm	kg	—	—	10 200*	8300	7400*	5300	5700*	3800	3800*	3500
7'3"	lb	—	—	22,491*	18,302	16,317*	11,687	12,569*	8379	8379*	7718
2500 mm	kg	—	—	10 200*	8400	7400*	5400	5700*	3800	2900*	2900*
8'2"	lb	—	—	22,491*	18,522	16,317*	11,907	12,569*	8379	6395*	6395*
2800 mm	kg	5000*	5000*	10 200*	8400	7300*	5300	5700*	3800	2600*	2600*
9'2"	lb	11,025*	11,025*	22,491*	18,522	16,097*	11,687	12,569*	8379	5733*	5733*

M318D/M320D2 ● Dozer and Stabilizer Down

Stick		3 m 9'10"		4.5 m 15'0"		6 m 20'0"		7.5 m 25'0"		At Max. Reach	
		Front	Side	Front	Side	Front	Side	Front	Side	Front	Side
2200 mm	kg	—	—	10 200*	6800	7400*	4400	5700*	3200	3800*	2900
7'3"	lb	—	—	22,491*	14,994	16,317*	9702	12,569*	7056	8379*	6395
2500 mm	kg	—	—	10 200*	6900	7400*	4500	5700*	3200	2900*	2800
8'2"	lb	—	—	22,491*	15,215	16,317*	9923	12,569*	7056	6395*	6174
2800 mm	kg	5000*	5000*	10 200*	6900	7300*	4500	5700*	3200	2600*	2600*
9'2"	lb	11,025*	11,025*	22,491*	15,215	16,097*	9923	12,569*	7056	5733*	5733*

*Load limited by hydraulic capacity rather than tipping.

M318D/M320D2 ● Rear Dozer Up

Stick		3 m 9'10"		4.5 m 15'0"		6 m 20'0"		7.5 m 25'0"		At Max. Reach	
		Front	Side	Front	Side	Front	Side	Front	Side	Front	Side
2200 mm	kg	14 500	8000	7500	4400	4700	2800	3100	1800	2800	1600
7'3"	lb	31,973	17,640	16,538	9702	10,364	6174	6836	3969	6174	3528
2500 mm	kg	14 500	8100	7500	4500	4800	2900	3200	1900	2700*	1500
8'2"	lb	31,973	17,861	16,538	9923	10,584	6395	7056	4190	5954*	3308
2800 mm	kg	14 100	8200	7400	4500	4900	3000	3200	1900	2300*	1400
9'2"	lb	31,091	18,081	16,317	9923	10,805	6615	7056	4190	5072*	3087

M318D/M320D2 ● Rear Dozer Down

Stick		3 m 9'10"		4.5 m 15'0"		6 m 20'0"		7.5 m 25'0"		At Max. Reach	
		Front	Side	Front	Side	Front	Side	Front	Side	Front	Side
2200 mm	kg	15 000*	9500	10 100*	5100	7300*	3300	5000	2100	3500*	1900
7'3"	lb	33,075*	20,948	22,271*	11,246	16,097*	7277	11,025	4631	7718*	4190
2500 mm	kg	14 600*	9600	10 100*	5200	7300*	3400	5100	2200	2700*	1800
8'2"	lb	32,193*	21,168	22,271*	11,466	16,097*	7497	11,246	4851	5954*	3969
2800 mm	kg	14 100*	9700	10 100*	5200	7200*	3400	5100	2200	2300*	1700
9'2"	lb	31,091*	21,389	22,271*	11,466	15,876*	7497	11,246	4851	5072*	3749

M318D/M320D2 ● Rear Stabilizer Down

Stick		3 m 9'10"		4.5 m 15'0"		6 m 20'0"		7.5 m 25'0"		At Max. Reach	
		Front	Side	Front	Side	Front	Side	Front	Side	Front	Side
2200 mm	kg	15 000*	12 100	10 100*	6300	6600	4000	4400	2600	3500*	2400
7'3"	lb	33,075*	26,681	22,271*	13,892	14,553	8820	9702	5733	7718*	5292
2500 mm	kg	14 600*	12 100	10 100*	6400	6600	4100	4400	2700	2700*	2200
8'2"	lb	32,193*	26,681	22,271*	14,112	14,553	9041	9702	5954	5954*	4851
2800 mm	kg	14 100*	12 000	10 100*	6400	6500	4100	4500	2700	2300*	2100
9'2"	lb	31,091*	26,460	22,271*	14,112	14,333	9041	9923	5954	5072*	4631

M318D/M320D2 ● 4-Point Stabilizers Down

Stick		3 m 9'10"		4.5 m 15'0"		6 m 20'0"		7.5 m 25'0"		At Max. Reach	
		Front	Side	Front	Side	Front	Side	Front	Side	Front	Side
2200 mm	kg	15 000*	15 000*	10 100*	8900	7300*	5700	5500*	3900	3500*	3500*
7'3"	lb	33,075*	33,075*	22,271*	19,625	16,097*	12,569	12,128*	8600	7718*	7718*
2500 mm	kg	14 600*	14 600*	10 100*	8900	7300*	5800	5700*	3900*	2700*	2700*
8'2"	lb	32,193*	32,193*	22,271*	19,625	16,097*	12,789	12,569*	8599*	5954*	5954*
2800 mm	kg	14 100*	14 100*	10 100*	8900	7300*	5800	5700*	3900	2300*	2300*
9'2"	lb	31,091*	31,091*	22,271*	19,625	16,097*	12,789	12,569*	8600	5072*	5072*

M318D/M320D2 ● Dozer and Stabilizer Down

Stick		3 m 9'10"		4.5 m 15'0"		6 m 20'0"		7.5 m 25'0"		At Max. Reach	
		Front	Side	Front	Side	Front	Side	Front	Side	Front	Side
2200 mm	kg	15 000*	14 800	10 100*	7600	7300*	4900	5500*	3200	3500*	2900
7'3"	lb	33,075*	32,634	22,271*	16,758	16,097*	10,805	12,128*	7056	7718*	6395
2500 mm	kg	14 600*	14 600*	10 100*	7600	7300*	4900	5700*	3300	2700*	2700*
8'2"	lb	32,193*	32,193*	22,271*	16,758	16,097*	10,805	12,569*	7277	5954*	5954*
2800 mm	kg	14 100*	14 100*	10 100*	7600	7300*	5000	5700*	3300	2300*	2300*
9'2"	lb	31,091*	31,091*	22,271*	16,758	16,097*	11,025	12,569*	7277	5072*	5072*

*Load limited by hydraulic capacity rather than tipping.

M322D/M322D2 ● Rear Dozer Up

Stick		3 m 9'10"		4.5 m 15'0"		6 m 20'0"		7.5 m 25'0"		At Max. Reach	
		Front	Side	Front	Side	Front	Side	Front	Side	Front	Side
2200 mm	kg	—	—	7200	4400	4700	2900	3400	2100	2800	1800
7'3"	lb	—	—	15,876	9702	10,364	6395	7497	4631	6174	3969
2500 mm	kg	—	—	7200	4400	4700	2900	3400	2100	2600*	1700
8'2"	lb	—	—	15,876	9702	10,364	6395	7497	4631	5733*	3749
2900 mm	kg	—	—	7200	4400	4700	2900	3400	2100	2200*	1500
9'6"	lb	—	—	15,876	9702	10,364	6395	7497	4631	4851*	3308

M322D/M322D2 ● Rear Dozer Down

Stick		3 m 9'10"		4.5 m 15'0"		6 m 20'0"		7.5 m 25'0"		At Max. Reach	
		Front	Side	Front	Side	Front	Side	Front	Side	Front	Side
2200 mm	kg	—	—	11 800*	5100	8500	3400	5900	2500	2900*	2000
7'3"	lb	—	—	26,019*	11,246	18,743	7497	13,010	5513	6395*	4410
2500 mm	kg	—	—	11 900*	5100	8500	3400	5900	2500	2600*	1900
8'2"	lb	—	—	26,240*	11,246	18,743	7497	13,010	5513	5733*	4190
2900 mm	kg	—	—	11 800*	5100	8500*	3400	5800	2400	2200*	1800
9'6"	lb	—	—	26,019*	11,246	18,743*	7497	12,789	5292	4851*	3969

M322D/M322D2 ● Rear Stabilizer Down

Stick		3 m 9'10"		4.5 m 15'0"		6 m 20'0"		7.5 m 25'0"		At Max. Reach	
		Front	Side	Front	Side	Front	Side	Front	Side	Front	Side
2200 mm	kg	—	—	11 800*	6400	7300	4200	5100	3100	2900*	2500
7'3"	lb	—	—	26,019*	14,112	16,097	9261	11,246	6836	6395*	5513
2500 mm	kg	—	—	11 900*	6400	7300	4200	5100	3100	2600*	2400
8'2"	lb	—	—	26,240*	14,112	16,097	9261	11,246	6836	5733*	5292
2900 mm	kg	—	—	11 800*	6400	7300	4200	5100	3000	2200*	2200
9'6"	lb	—	—	26,019*	14,112	16,097	9261	11,246	6615	4851*	4851

M322D/M322D2 ● 4-Point Stabilizers Down

Stick		3 m 9'10"		4.5 m 15'0"		6 m 20'0"		7.5 m 25'0"		At Max. Reach	
		Front	Side	Front	Side	Front	Side	Front	Side	Front	Side
2200 mm	kg	—	—	11 800*	10 100	8600*	6400	6600*	4600	2900*	2900*
7'3"	lb	—	—	26,019*	22,271	18,963*	14,112	14,553*	10,143	6395*	6395*
2500 mm	kg	—	—	11 900*	10 100	8600*	6400	6600*	4600	2600*	2600*
8'2"	lb	—	—	26,240*	22,271	18,963*	14,112	14,553*	10,143	5733*	5733*
2900 mm	kg	—	—	11 800*	10 100	8500*	6200	6600*	4500	2200*	2200*
9'6"	lb	—	—	26,019*	22,271	18,743*	13,671	14,553*	9923	4851*	4851*

M322D/M322D2 ● Dozer and Stabilizer Down

Stick		3 m 9'10"		4.5 m 15'0"		6 m 20'0"		7.5 m 25'0"		At Max. Reach	
		Front	Side	Front	Side	Front	Side	Front	Side	Front	Side
2200 mm	kg	—	—	11 800*	8300	8600*	5400	6600*	3900	2900*	2900*
7'3"	lb	—	—	26,019*	18,302	18,963*	11,907	14,553*	8600	6395*	6395*
2500 mm	kg	—	—	11 900*	8300	8600*	5400	6600*	3900	2600*	2600*
8'2"	lb	—	—	26,240*	18,302	18,963*	11,907	14,553*	8600	5733*	5733*
2900 mm	kg	—	—	11 800*	8300	8500*	5400	6600*	3800	2200*	2200*
9'6"	lb	—	—	26,019*	18,302	18,743*	11,907	14,553*	8379	4851*	4851*

*Load limited by hydraulic capacity rather than tipping.

M322D/M322D2 ● Rear Dozer Up

Stick		3 m 9'10"		4.5 m 15'0"		6 m 20'0"		7.5 m 25'0"		At Max. Reach	
		Front	Side	Front	Side	Front	Side	Front	Side	Front	Side
2200 mm	kg	16 100	9500	8300	5300	5300	3500	3500	2200	2700*	1800
7'3"	lb	35,501	20,948	18,302	11,687	11,687	7718	7718	4851	5954*	3969
2500 mm	kg	16 100	9800	8300	5400	5300	3500	3500	5300	2500*	1700
8'2"	lb	35,501	21,609	18,302	11,907	11,687	7718	7718	11,687	5513*	3749
2900 mm	kg	15 800	9900	8200	5400	5400	3500	3600	2300	2100*	1500
9'6"	lb	34,839	21,830	18,081	11,907	11,907	7718	7938	5072	4631*	3308

M322D/M322D2 ● Rear Dozer Down

Stick		3 m 9'10"		4.5 m 15'0"		6 m 20'0"		7.5 m 25'0"		At Max. Reach	
		Front	Side	Front	Side	Front	Side	Front	Side	Front	Side
2200 mm	kg	16 700*	11 300	11 800*	6100	8500*	4000	6100	2600	2700*	2100
7'3"	lb	36,825*	24,917	26,019*	13,451	18,743*	8820	13,451	5733	5954*	4631
2500 mm	kg	16 400*	11 600	11 800*	6200	8500*	4000	6100	2600	2500*	2000
8'2"	lb	36,162*	25,578	26,019*	13,671	18,743*	8820	13,451	5733	5513*	4410
2900 mm	kg	15 800*	11 700	11 700*	6200	8400*	4000	6100	2700	2100*	1800
9'6"	lb	34,839*	25,799	25,799*	13,671	18,522*	8820	13,451	5954	4631*	3969

M322D/M322D2 ● Rear Stabilizer Down

Stick		3 m 9'10"		4.5 m 15'0"		6 m 20'0"		7.5 m 25'0"		At Max. Reach	
		Front	Side	Front	Side	Front	Side	Front	Side	Front	Side
2200 mm	kg	16 700*	16 700	11 800*	10 800	8500	7100	6700	4700	2700*	2700
7'3"	lb	36,825*	36,824	26,019*	23,814	18,743	15,656	14,774	10,364	5954*	5954
2500 mm	kg	16 400*	14 600	11 800*	7600	7800	4900	5300	6200	2500*	2400
8'2"	lb	36,162*	32,193	26,019*	16,758	17,199	10,805	11,687	13,671	5513*	5292
2900 mm	kg	15 800*	14 400	11 700*	7500	7700	4900	5400	3300	2100*	2100*
9'6"	lb	34,839*	31,752	25,799*	16,538	16,979	10,805	11,907	7277	4631*	4631*

M322D/M322D2 ● 4-Point Stabilizers Down

Stick		3 m 9'10"		4.5 m 15'0"		6 m 20'0"		7.5 m 25'0"		At Max. Reach	
		Front	Side	Front	Side	Front	Side	Front	Side	Front	Side
2200 mm	kg	16 700*	16 700*	11 800*	10 800	8500*	7100	6700*	4700	2700*	2700*
7'3"	lb	36,825*	36,825*	26,019*	23,814	18,743*	15,656	14,744*	10,364	5954*	5954*
2500 mm	kg	16 400*	16 400*	11 800*	10 800	8500*	7000	6600*	4700	2500*	2500*
8'2"	lb	36,162*	36,162*	26,019*	23,814	18,743*	15,435	14,553*	10,364	5513*	5513*
2900 mm	kg	15 800*	15 800*	11 700*	10 700	8400*	6900	6500*	4800	2100*	2100*
9'6"	lb	34,839*	34,839*	25,799*	23,594	18,522*	15,215	14,333*	10,584	4631*	4631*

M322D/M322D2 ● Dozer and Stabilizer Down

Stick		3 m 9'10"		4.5 m 15'0"		6 m 20'0"		7.5 m 25'0"		At Max. Reach	
		Front	Side	Front	Side	Front	Side	Front	Side	Front	Side
2200 mm	kg	16 700*	16 700*	11 800*	9300	8500*	6100	6700*	4000	2700*	2700*
7'3"	lb	36,825*	36,825*	26,019*	20,507	18,743*	13,451	14,744*	8820	5954*	5954*
2500 mm	kg	16 400*	16 400*	11 800*	9200	8500*	6100	6600*	4000	2500*	2500*
8'2"	lb	36,162*	36,162*	26,019*	20,286	18,743*	13,451	14,553*	8820	5513*	5513*
2900 mm	kg	15 800*	15 800*	11 700*	9100	8500*	6000	6500*	4100	2100*	2100*
9'6"	lb	34,839*	34,839*	25,799*	20,066	18,743*	13,230	14,333*	9041	4631*	4631*

*Load limited by hydraulic capacity rather than tipping.

Lifting Capacity At Ground Level
 ● M318F ● One-Piece Boom
 ● 3400 kg (7496 lb) Counterweight

**Hydraulic
Excavators**

M318F ● Rear Dozer Up

Stick		3 m 9'10"		4.5 m 15'0"		6 m 20'0"		7.5 m 25'0"		At Max. Reach	
		Rear	Side	Rear	Side	Rear	Side	Rear	Side	Rear	Side
2100 mm 6'11"	kg lb	—	—	4100 9039	3500 7716	2750 6063	2400 5291	—	—	2200 4850	1900 4189
2400 mm 7'10"	kg lb	—	—	4100 9039	3500 7716	2750 6063	2350 5181	—	—	2050 4519	1800 3968
2600 mm 8'6"	kg lb	4400* 9700	4400* 9700	4100 9039	3500 7716	2750 6063	2350 5181	2000 4409	1750 3858	2000 4409	1700 3748

M318F ● Rear Dozer Up

Stick		3 m 9'10"		4.5 m 15'0"		6 m 20'0"		7.5 m 25'0"		At Max. Reach	
		Front	Side	Front	Side	Front	Side	Front	Side	Front	Side
2100 mm 6'11"	kg lb	—	—	6200 13,669	3500 7716	4100 9039	2400 5291	—	—	3200 7055	1900 4189
2400 mm 7'10"	kg lb	—	—	6200 13,669	3500 7716	4050 8929	2350 5181	—	—	3050 6724	1800 3968
2600 mm 8'6"	kg lb	4400* 9700	4400* 9700	6200 13,669	3500 7716	4050 8929	2350 5181	2950 6504	1750 3858	2900 6393	1700 3748

M318F ● Rear Dozer Down

Stick		3 m 9'10"		4.5 m 15'0"		6 m 20'0"		7.5 m 25'0"		At Max. Reach	
		Rear	Side	Rear	Side	Rear	Side	Rear	Side	Rear	Side
2100 mm 6'11"	kg lb	—	—	8800* 19,401	4100 9039	6350 13,999	2750 6063	—	—	4250* 9370	2200 4850
2400 mm 7'10"	kg lb	—	—	8850* 19,511	4100 9039	6350 13,999	2750 6063	—	—	3650* 8047	2050 4519
2600 mm 8'6"	kg lb	4400* 9700	4400* 9700	8850* 19,511	4100 9039	6350 13,999	2750 6063	4000* 8818	2000 4409	3300* 7275	2000 4409

M318F ● Front Dozer and Rear Stabilizer Down

Stick		3 m 9'10"		4.5 m 15'0"		6 m 20'0"		7.5 m 25'0"		At Max. Reach	
		Rear	Side	Rear	Side	Rear	Side	Rear	Side	Rear	Side
2100 mm 6'11"	kg lb	—	—	8800* 19,401	6550 14,440	6400* 14,110	4300 9480	—	—	4250* 9370	3400 7496
2400 mm 7'10"	kg lb	—	—	8850* 19,511	6550 14,440	6400 14,110	4250 9370	—	—	3650* 8047	3200 7055
2600 mm 8'6"	kg lb	4400* 9700	4400* 9700	8850* 19,511	6550 14,440	6400 14,110	4250 9370	4000* 8818	3100 6834	3300* 7275	3050 6724

M318F ● 4-Point Stabilizer Down

Stick		3 m 9'10"		4.5 m 15'0"		6 m 20'0"		7.5 m 25'0"		At Max. Reach	
		Front	Side	Front	Side	Front	Side	Front	Side	Front	Side
2100 mm 6'11"	kg lb	—	—	8800* 19,401	7800 17,196	6400* 14,110	5000 11,023	—	—	4250* 9370	3950 8708
2400 mm 7'10"	kg lb	—	—	8850* 19,511	7800 17,196	6450* 14,220	5000 11,023	—	—	3650* 8047	3650* 8047
2600 mm 8'6"	kg lb	4400* 9700	4400* 9700	8850* 19,511	7800 17,196	6450* 14,220	5000 11,023	4000* 8818	3650 8047	3300* 7275	3300* 7275

*Indicates that the load is limited by hydraulic lifting capacity rather than tipping load.

NOTE: Oscillating axle needs to be locked. Weight of all lifting accessories must be subtracted from the lifting capacities.

All lift capacities calculated and rated per ISO 10567:2007. Rated loads do not exceed 87% of hydraulic lift capacity or 75% of tipping load.

Lifting capacities are based on the machine standing on a firm uniform supporting surface. The load point is the center line of the bucket pivot mounting pin on the stick.

Hydraulic Excavators

Lifting Capacity At Ground Level

- M318F ● One-Piece Boom
- 3900 kg (8598 lb) Counterweight

M318F ● Rear Dozer Up

Stick		3 m 9'10"		4.5 m 15'0"		6 m 20'0"		7.5 m 25'0"		At Max. Reach	
		Rear	Side	Rear	Side	Rear	Side	Rear	Side	Rear	Side
2100 mm 6'11"	kg lb	—	—	4450 9811	3800 8378	3000 6614	2600 5732	—	—	2400 5291	2100 4630
2400 mm 7'10"	kg lb	—	—	4450 9811	3800 8378	3000 6614	2600 5732	—	—	2250 4960	1950 4299
2600 mm 8'6"	kg lb	4400* 9700	4400* 9700	4450 9811	3800 8378	3000 6614	2600 5732	2200 4850	1900 4189	2150 4740	1900 4189

M318F ● Rear Dozer Up

Stick		3 m 9'10"		4.5 m 15'0"		6 m 20'0"		7.5 m 25'0"		At Max. Reach	
		Front	Side	Front	Side	Front	Side	Front	Side	Front	Side
2100 mm 6'11"	kg lb	—	—	6600 14,551	3800 8378	4350 9590	2600 5732	—	—	3450 7606	2100 4630
2400 mm 7'10"	kg lb	—	—	6600 14,551	3800 8378	4350 9590	2600 5732	—	—	3250 7165	1950 4299
2600 mm 8'6"	kg lb	4400* 9700	4400* 9700	6600 14,551	3800 8378	4350 9590	2600 5732	3200 7055	1900 4189	3150 6945	1900 4189

M318F ● Rear Dozer Down

Stick		3 m 9'10"		4.5 m 15'0"		6 m 20'0"		7.5 m 25'0"		At Max. Reach	
		Rear	Side	Rear	Side	Rear	Side	Rear	Side	Rear	Side
2100 mm 6'11"	kg lb	—	—	8800* 19,401	4400 9700	6400* 14,110	3000 6614	—	—	4250* 9370	2400 5291
2400 mm 7'10"	kg lb	—	—	8850* 19,511	4400 9700	6450* 14,220	3000 6614	—	—	3650* 8047	2250 4960
2600 mm 8'6"	kg lb	4400* 9700	4400* 9700	8850* 19,511	4400 9700	6450* 14,220	3000 6614	4000* 8818	2200 4850	3300* 7275	2150 4740

M318F ● Front Dozer and Rear Stabilizer Down

Stick		3 m 9'10"		4.5 m 15'0"		6 m 20'0"		7.5 m 25'0"		At Max. Reach	
		Rear	Side	Rear	Side	Rear	Side	Rear	Side	Rear	Side
2100 mm 6'11"	kg lb	—	—	8800* 19,401	6950 15,322	6400* 14,110	4550 10,031	—	—	4250* 9370	3600 7937
2400 mm 7'10"	kg lb	—	—	8850* 19,511	6950 15,322	6450* 14,220	4550 10,031	—	—	3650* 8047	3400 7496
2600 mm 8'6"	kg lb	4400* 9700	4400* 9700	8850* 19,511	6950 15,322	6450* 14,220	4550 10,031	4000* 8818	3350 7385	3300* 7275	3300 7275

M318F ● 4-Point Stabilizer Down

Stick		3 m 9'10"		4.5 m 15'0"		6 m 20'0"		7.5 m 25'0"		At Max. Reach	
		Front	Side	Front	Side	Front	Side	Front	Side	Front	Side
2100 mm 6'11"	kg lb	—	—	8800* 19,401	8250 18,188	6400* 14,110	5350 11,795	—	—	4250* 9370	4200 9259
2400 mm 7'10"	kg lb	—	—	8850* 19,511	8250 18,188	6450* 14,220	5300 11,684	—	—	3650* 8047	3650* 8047
2600 mm 8'6"	kg lb	4400* 9700	4400* 9700	8850* 19,511	8250 18,188	6450* 14,220	5300 11,684	4000* 8818	3850 8488	3300* 7275	3300* 7275

*Indicates that the load is limited by hydraulic lifting capacity rather than tipping load.

NOTE: Oscillating axle needs to be locked. Weight of all lifting accessories must be subtracted from the lifting capacities.

All lift capacities calculated and rated per ISO 10567:2007. Rated loads do not exceed 87% of hydraulic lift capacity or 75% of tipping load.

Lifting capacities are based on the machine standing on a firm uniform supporting surface. The load point is the center line of the bucket pivot mounting pin on the stick.

- M318F ● Lifting Capacity At Ground Level
- Hydraulically Adjustable Boom
- 3400 kg (7496 lb) Counterweight

Hydraulic Excavators

M318F ● Rear Dozer Up

Stick		3 m 9'10"		4.5 m 15'0"		6 m 20'0"		7.5 m 25'0"		At Max. Reach	
		Rear	Side	Rear	Side	Rear	Side	Rear	Side	Rear	Side
2100 mm	kg	—	—	4000	3400	2700	2300	—	—	2050	1750
6'11"	lb	—	—	8818	7496	5952	5071	—	—	4519	3858
2400 mm	kg	—	—	4000	3350	2650	2300	1950	1700	1950	1650
7'10"	lb	—	—	8818	7385	5842	5071	4299	3748	4299	3638
2600 mm	kg	—	—	4000	3350	2650	2300	1950	1700	1850	1600
8'6"	lb	—	—	8818	7385	5842	5071	4299	3748	4079	3527

M318F ● Rear Dozer Up

Stick		3 m 9'10"		4.5 m 15'0"		6 m 20'0"		7.5 m 25'0"		At Max. Reach	
		Front	Side	Front	Side	Front	Side	Front	Side	Front	Side
2100 mm	kg	—	—	6100	3400	4050	2300	—	—	3050	1750
6'11"	lb	—	—	13,448	7496	8929	5071	—	—	6724	3858
2400 mm	kg	—	—	6100	3350	4000	2300	2950	1700	2900	1650
7'10"	lb	—	—	13,448	7385	8818	5071	6504	3748	6393	3638
2600 mm	kg	—	—	6100	3350	4000	2300	2950	1700	2800	1600
8'6"	lb	—	—	13,448	7385	8818	5071	6504	3748	6173	3527

M318F ● Rear Dozer Down

Stick		3 m 9'10"		4.5 m 15'0"		6 m 20'0"		7.5 m 25'0"		At Max. Reach	
		Rear	Side	Rear	Side	Rear	Side	Rear	Side	Rear	Side
2100 mm	kg	—	—	8500*	4000	6250*	2700	—	—	4100*	2050
6'11"	lb	—	—	18,739	8818	13,779	5952	—	—	9039	4519
2400 mm	kg	—	—	8600*	3950	6300*	2700	4500	1950	3500*	1950
7'10"	lb	—	—	18,960	8708	13,889	5952	9921	4299	7716	4299
2600 mm	kg	—	—	8650*	3950	6200*	2700	4500	1950	3200*	1850
8'6"	lb	—	—	19,070	8708	13,669	5952	9921	4299	7055	4079

M318F ● Front Dozer and Rear Stabilizer Down

Stick		3 m 9'10"		4.5 m 15'0"		6 m 20'0"		7.5 m 25'0"		At Max. Reach	
		Rear	Side	Rear	Side	Rear	Side	Rear	Side	Rear	Side
2100 mm	kg	—	—	8500*	6450	6250*	4250	—	—	4100*	3200
6'11"	lb	—	—	18,739	14,220	13,779	9370	—	—	9039	7055
2400 mm	kg	—	—	8600*	6450	6300*	4250	4600	3100	3500*	3050
7'10"	lb	—	—	18,960	14,220	13,889	9370	10,141	6834	7716	6724
2600 mm	kg	—	—	8650*	6450	6200*	4250	4550	3100	3200*	2900
8'6"	lb	—	—	19,070	14,220	13,669	9370	10,031	6834	7055	6393

M318F ● 4-Point Stabilizer Down

Stick		3 m 9'10"		4.5 m 15'0"		6 m 20'0"		7.5 m 25'0"		At Max. Reach	
		Front	Side	Front	Side	Front	Side	Front	Side	Front	Side
2100 mm	kg	—	—	8500*	7750	6250*	5000	—	—	4100*	3750
6'11"	lb	—	—	18,739	17,086	13,779	11,023	—	—	9039	8267
2400 mm	kg	—	—	8600*	7750	6300*	5000	4600*	3600	3500*	3500*
7'10"	lb	—	—	18,960	17,086	13,889	11,023	10,141	7937	7716	7716
2600 mm	kg	—	—	8650*	7750	6200*	4950	4650*	3600	3200*	3200*
8'6"	lb	—	—	19,070	17,086	13,669	10,913	10,251	7937	7055	7055

*Indicates that the load is limited by hydraulic lifting capacity rather than tipping load.

NOTE: Oscillating axle needs to be locked. Weight of all lifting accessories must be subtracted from the lifting capacities.

All lift capacities calculated and rated per ISO 10567:2007. Rated loads do not exceed 87% of hydraulic lift capacity or 75% of tipping load.

Lifting capacities are based on the machine standing on a firm uniform supporting surface. The load point is the center line of the bucket pivot mounting pin on the stick.

Hydraulic Excavators

Lifting Capacity At Ground Level

- M318F ● Hydraulically Adjustable Boom
- 3900 kg (8598 lb) Counterweight

M318F ● Rear Dozer Up

Stick		3 m 9'10"		4.5 m 15'0"		6 m 20'0"		7.5 m 25'0"		At Max. Reach	
		Rear	Side	Rear	Side	Rear	Side	Rear	Side	Rear	Side
2100 mm	kg	—	—	4350	3700	2950	2500	—	—	2250	1950
6'11"	lb	—	—	9590	8157	6504	5512	—	—	4960	4299
2400 mm	kg	—	—	4350	3700	2900	2500	2150	1850	2100	1850
7'10"	lb	—	—	9590	8157	6393	5512	4740	4079	4630	4079
2600 mm	kg	—	—	4350	3700	2900	2500	2150	1850	2050	1750
8'6"	lb	—	—	9590	8157	6393	5512	4740	4079	4519	3858

M318F ● Rear Dozer Up

Stick		3 m 9'10"		4.5 m 15'0"		6 m 20'0"		7.5 m 25'0"		At Max. Reach	
		Front	Side	Front	Side	Front	Side	Front	Side	Front	Side
2100 mm	kg	—	—	6550	3700	4300	2500	—	—	3300	1950
6'11"	lb	—	—	14,440	8157	9480	5512	—	—	7275	4299
2400 mm	kg	—	—	6550	3700	4300	2500	3150	1850	3100	1850
7'10"	lb	—	—	14,440	8157	9480	5512	6945	4079	6834	4079
2600 mm	kg	—	—	6550	3700	4300	2500	3150	1850	3000	1750
8'6"	lb	—	—	14,440	8157	9480	5512	6945	4079	6614	3858

M318F ● Rear Dozer Down

Stick		3 m 9'10"		4.5 m 15'0"		6 m 20'0"		7.5 m 25'0"		At Max. Reach	
		Rear	Side	Rear	Side	Rear	Side	Rear	Side	Rear	Side
2100 mm	kg	—	—	8500*	4300	6250*	2950	—	—	4100*	2250
6'11"	lb	—	—	18,739	9480	13,779	6504	—	—	9039	4960
2400 mm	kg	—	—	8600*	4300	6300*	2900	4600*	2150	3500*	2100
7'10"	lb	—	—	18,960	9480	13,889	6393	10,141	4740	7716	4630
2600 mm	kg	—	—	8650*	4300	6200*	2900	4650*	2150	3200*	2050
8'6"	lb	—	—	19,070	9480	13,669	6393	10,251	4740	7055	4519

M318F ● Front Dozer and Rear Stabilizer Down

Stick		3 m 9'10"		4.5 m 15'0"		6 m 20'0"		7.5 m 25'0"		At Max. Reach	
		Rear	Side	Rear	Side	Rear	Side	Rear	Side	Rear	Side
2100 mm	kg	—	—	8500*	6900	6250*	4550	—	—	4100*	3450
6'11"	lb	—	—	18,739	15,212	13,779	10,031	—	—	9039	7606
2400 mm	kg	—	—	8600*	6900	6300*	4500	4600*	3300	3500*	3250
7'10"	lb	—	—	18,960	15,212	13,889	9921	10,141	7275	7716	7165
2600 mm	kg	—	—	8650*	6900	6200*	4500	4650*	3300	3200*	3100
8'6"	lb	—	—	19,070	15,212	13,669	9921	10,251	7275	7055	6834

M318F ● 4-Point Stabilizer Down

Stick		3 m 9'10"		4.5 m 15'0"		6 m 20'0"		7.5 m 25'0"		At Max. Reach	
		Front	Side	Front	Side	Front	Side	Front	Side	Front	Side
2100 mm	kg	—	—	8500*	8200	6250*	5300	—	—	4100*	4000
6'11"	lb	—	—	18,739	18,078	13,779	11,684	—	—	9039	8818
2400 mm	kg	—	—	8600*	8200	6300*	5300	4600*	3850	3500*	3500*
7'10"	lb	—	—	18,960	18,078	13,889	11,684	10,141	8488	7716	7716
2600 mm	kg	—	—	8650*	8200	6200*	5300	4650*	3850	3200*	3200*
8'6"	lb	—	—	19,070	18,078	13,669	11,684	10,251	8488	7055	7055

*Indicates that the load is limited by hydraulic lifting capacity rather than tipping load.

NOTE: Oscillating axle needs to be locked. Weight of all lifting accessories must be subtracted from the lifting capacities.

All lift capacities calculated and rated per ISO 10567:2007. Rated loads do not exceed 87% of hydraulic lift capacity or 75% of tipping load.

Lifting capacities are based on the machine standing on a firm uniform supporting surface. The load point is the center line of the bucket pivot mounting pin on the stick.

Lifting Capacity At Ground Level
 ● M318F ● Offset Boom
 ● 3400 kg (7496 lb) Counterweight

**Hydraulic
Excavators**

M318F ● Rear Dozer Up

Stick		3 m 9'10"		4.5 m 15'0"		6 m 20'0"		7.5 m 25'0"		At Max. Reach	
		Rear	Side	Rear	Side	Rear	Side	Rear	Side	Rear	Side
2100 mm	kg	—	—	3700	3100	2500	2100	—	—	1900	1600
6'11"	lb	—	—	8157	6834	5512	4630	—	—	4189	3527
2400 mm	kg	—	—	3700	3100	2500	2100	1800	1550	1750	1500
7'10"	lb	—	—	8157	6834	5512	4630	3968	3417	3858	3307
2600 mm	kg	—	—	3700	3100	2500	2100	1800	1500	1700	1450
8'6"	lb	—	—	8157	6834	5512	4630	3968	3307	3748	3197

M318F ● Rear Dozer Up

Stick		3 m 9'10"		4.5 m 15'0"		6 m 20'0"		7.5 m 25'0"		At Max. Reach	
		Front	Side	Front	Side	Front	Side	Front	Side	Front	Side
2100 mm	kg	—	—	5850	3100	3850	2100	—	—	2900	1600
6'11"	lb	—	—	12,897	6834	8488	4630	—	—	6393	3527
2400 mm	kg	—	—	5850	3100	3850	2100	2800	1550	2750	1500
7'10"	lb	—	—	12,897	6834	8488	4630	6173	3417	6063	3307
2600 mm	kg	—	—	5850	3100	3850	2100	2800	1500	2650	1450
8'6"	lb	—	—	12,897	6834	8488	4630	6173	3307	5842	3197

M318F ● Rear Dozer Down

Stick		3 m 9'10"		4.5 m 15'0"		6 m 20'0"		7.5 m 25'0"		At Max. Reach	
		Rear	Side	Rear	Side	Rear	Side	Rear	Side	Rear	Side
2100 mm	kg	—	—	8150*	3700	5950*	2500	—	—	3600*	1900
6'11"	lb	—	—	17,968	8157	13,118	5512	—	—	7937	4189
2400 mm	kg	—	—	8250*	3700	6000*	2500	4400	1800	3100*	1800
7'10"	lb	—	—	18,188	8157	13,228	5512	9700	3968	6834	3968
2600 mm	kg	—	—	8300*	3700	6050*	2500	4350	1800	2800*	1700
8'6"	lb	—	—	18,298	8157	13,338	5512	9590	3968	6173	3748

M318F ● Front Dozer and Rear Stabilizer Down

Stick		3 m 9'10"		4.5 m 15'0"		6 m 20'0"		7.5 m 25'0"		At Max. Reach	
		Rear	Side	Rear	Side	Rear	Side	Rear	Side	Rear	Side
2100 mm	kg	—	—	8150*	6200	5950*	4050	—	—	3600*	3050
6'11"	lb	—	—	17,968	13,669	13,118	8929	—	—	7937	6724
2400 mm	kg	—	—	8250*	6200	6000*	4050	4450*	2950	3100*	2900
7'10"	lb	—	—	18,188	13,669	13,228	8929	9811	6504	6834	6393
2600 mm	kg	—	—	8300*	6200	6050*	4050	4450	2950	2800*	2800
8'6"	lb	—	—	18,298	13,669	13,338	8929	9811	6504	6173	6173

M318F ● 4-Point Stabilizer Down

Stick		3 m 9'10"		4.5 m 15'0"		6 m 20'0"		7.5 m 25'0"		At Max. Reach	
		Front	Side	Front	Side	Front	Side	Front	Side	Front	Side
2100 mm	kg	—	—	8150*	7450	5950*	4800	—	—	3600*	3600*
6'11"	lb	—	—	17,968	16,424	13,118	10,582	—	—	7937	7937
2400 mm	kg	—	—	8250*	7450	6000*	4800	4450*	3500	3100*	3100*
7'10"	lb	—	—	18,188	16,424	13,228	10,582	9811	7716	6834	6834
2600 mm	kg	—	—	8300*	7500	6050*	4800	4500*	3450	2800*	2800*
8'6"	lb	—	—	18,298	16,535	13,338	10,582	9921	7606	6173	6173

*Indicates that the load is limited by hydraulic lifting capacity rather than tipping load.

NOTE: Oscillating axle needs to be locked. Weight of all lifting accessories must be subtracted from the lifting capacities.

All lift capacities calculated and rated per ISO 10567:2007. Rated loads do not exceed 87% of hydraulic lift capacity or 75% of tipping load.

Lifting capacities are based on the machine standing on a firm uniform supporting surface. The load point is the center line of the bucket pivot mounting pin on the stick.

Hydraulic Excavators

Lifting Capacity At Ground Level

- M318F ● Offset Boom
- 3900 kg (8598 lb) Counterweight

M318F ● Rear Dozer Up

Stick		3 m 9'10"		4.5 m 15'0"		6 m 20'0"		7.5 m 25'0"		At Max. Reach	
		Rear	Side	Rear	Side	Rear	Side	Rear	Side	Rear	Side
2100 mm	kg	—	—	4050	3400	2750	2300	—	—	2100	1750
6'11"	lb	—	—	8929	7496	6063	5071	—	—	4630	3858
2400 mm	kg	—	—	4050	3400	2700	2300	2000	1700	1950	1650
7'10"	lb	—	—	8929	7496	5952	5071	4409	3748	4299	3638
2600 mm	kg	—	—	4050	3400	2700	2300	2000	1700	1850	1600
8'6"	lb	—	—	8929	7496	5952	5071	4409	3748	4079	3527

M318F ● Rear Dozer Up

Stick		3 m 9'10"		4.5 m 15'0"		6 m 20'0"		7.5 m 25'0"		At Max. Reach	
		Front	Side	Front	Side	Front	Side	Front	Side	Front	Side
2100 mm	kg	—	—	6250	3400	4150	2300	—	—	3150	1750
6'11"	lb	—	—	13,779	7496	9149	5071	—	—	6945	3858
2400 mm	kg	—	—	6250	3400	4100	2300	3000	1700	2950	1650
7'10"	lb	—	—	13,779	7496	9039	5071	6614	3748	6504	3638
2600 mm	kg	—	—	6250	3400	4100	2300	3000	1700	2800*	1600
8'6"	lb	—	—	13,779	7496	9039	5071	6614	3748	6173	3527

M318F ● Rear Dozer Down

Stick		3 m 9'10"		4.5 m 15'0"		6 m 20'0"		7.5 m 25'0"		At Max. Reach	
		Rear	Side	Rear	Side	Rear	Side	Rear	Side	Rear	Side
2100 mm	kg	—	—	8150*	4050	5950*	2750	—	—	3600*	2100
6'11"	lb	—	—	17,968	8929	13,118	6063	—	—	7937	4630
2400 mm	kg	—	—	8250*	4000	6000*	2700	4450*	2000	3100*	1950
7'10"	lb	—	—	18,188	8818	13,228	5952	9811	4409	6834	4299
2600 mm	kg	—	—	—	4050	6050*	2700	4500*	2000	2800*	1900
8'6"	lb	—	—	—	8929	13,338	5952	9921	4409	6173	4189

M318F ● Front Dozer and Rear Stabilizer Down

Stick		3 m 9'10"		4.5 m 15'0"		6 m 20'0"		7.5 m 25'0"		At Max. Reach	
		Rear	Side	Rear	Side	Rear	Side	Rear	Side	Rear	Side
2100 mm	kg	—	—	8150*	6650	5950*	4350	—	—	3600*	3300
6'11"	lb	—	—	17,968	14,661	13,118	9590	—	—	7937	7275
2400 mm	kg	—	—	8250*	6600	6000*	4350	4450*	3150	3100*	3100*
7'10"	lb	—	—	18,188	14,551	13,228	9590	9811	6945	6834	6834
2600 mm	kg	—	—	8300*	6650	6050*	4350	4500*	3150	2800*	2800*
8'6"	lb	—	—	18,298	14,661	13,338	9590	9921	6945	6173	6173

M318F ● 4-Point Stabilizer Down

Stick		3 m 9'10"		4.5 m 15'0"		6 m 20'0"		7.5 m 25'0"		At Max. Reach	
		Front	Side	Front	Side	Front	Side	Front	Side	Front	Side
2100 mm	kg	—	—	8150*	7950	5950*	5150	—	—	3600*	3600*
6'11"	lb	—	—	17,968	17,527	13,118	11,354	—	—	7937	7937
2400 mm	kg	—	—	8250*	7950	6000*	5100	4450*	3700	3100*	3100*
7'10"	lb	—	—	18,188	17,527	13,228	11,244	9811	8157	6834	6834
2600 mm	kg	—	—	8300*	7950	6050*	5100	4500*	3700	2800*	2800*
8'6"	lb	—	—	18,298	17,527	13,338	11,244	9921	8157	6173	6173

*Indicates that the load is limited by hydraulic lifting capacity rather than tipping load.

NOTE: Oscillating axle needs to be locked. Weight of all lifting accessories must be subtracted from the lifting capacities.

All lift capacities calculated and rated per ISO 10567:2007. Rated loads do not exceed 87% of hydraulic lift capacity or 75% of tipping load.

Lifting capacities are based on the machine standing on a firm uniform supporting surface. The load point is the center line of the bucket pivot mounting pin on the stick.

Lifting Capacity At Ground Level
 ● M320F ● One-Piece Boom
 ● 3700 kg (8157 lb) Counterweight

**Hydraulic
Excavators**

M320F ● Rear Dozer Up

Stick		3 m 9'10"		4.5 m 15'0"		6 m 20'0"		7.5 m 25'0"		At Max. Reach	
		Rear	Side	Rear	Side	Rear	Side	Rear	Side	Rear	Side
2200 mm 7'3"	kg lb	—	—	4450 9811	3800 8378	3000 6614	2600 5732	—	—	2250 4960	1950 4299
2500 mm 8'2"	kg lb	—	—	4500 9921	3800 8378	3000 6614	2600 5732	2200 4850	1900 4189	2100 4630	1850 4079
2800 mm 9'2"	kg lb	—	—	4500 9921	3800 8378	3000 6614	2600 5732	2200 4850	1900 4189	2000 4409	1700 3748

M320F ● Rear Dozer Up

Stick		3 m 9'10"		4.5 m 15'0"		6 m 20'0"		7.5 m 25'0"		At Max. Reach	
		Front	Side	Front	Side	Front	Side	Front	Side	Front	Side
2200 mm 7'3"	kg lb	—	—	6700 14,771	3800 8378	4400 9700	2600 5732	—	—	3300 7275	1950 4299
2500 mm 8'2"	kg lb	—	—	6750 14,881	3800 8378	4400 9700	2600 5732	3250 7165	1900 4189	3100 6834	1850 4079
2800 mm 9'2"	kg lb	—	—	6750 14,881	3800 8378	4400 9700	2600 5732	3200 7055	1900 4189	2900 6393	1700 3748

M320F ● Rear Dozer Down

Stick		3 m 9'10"		4.5 m 15'0"		6 m 20'0"		7.5 m 25'0"		At Max. Reach	
		Rear	Side	Rear	Side	Rear	Side	Rear	Side	Rear	Side
2200 mm 7'3"	kg lb	—	—	10 200* 22,487	4450 9811	6900 15,212	3000 6614	—	—	5000 11,023	2250 4960
2500 mm 8'2"	kg lb	—	—	10 250* 22,597	4450 9811	6950 15,322	3000 6614	4900 10,803	2200 4850	4100* 9039	2100 4630
2800 mm 9'2"	kg lb	—	—	10 200* 22,487	4450 9811	6950 15,322	3000 6614	4900 10,803	2200 4850	3500* 7716	2000 4409

M320F ● Front Dozer and Rear Stabilizer Down

Stick		3 m 9'10"		4.5 m 15'0"		6 m 20'0"		7.5 m 25'0"		At Max. Reach	
		Rear	Side	Rear	Side	Rear	Side	Rear	Side	Rear	Side
2200 mm 7'3"	kg lb	—	—	10 200* 22,487	7100 15,653	6950 15,322	4650 10,251	—	—	5050 11,133	3450 7606
2500 mm 8'2"	kg lb	—	—	10 250* 22,597	7100 15,653	6950 15,322	4650 10,251	4950 10,913	3400 7496	4100* 9039	3250 7165
2800 mm 9'2"	kg lb	—	—	10 200* 22,487	7100 15,653	6950 15,322	4650 10,251	4950 10,913	3350 7385	3500* 7716	3050 6724

M320F ● 4-Point Stabilizer Down

Stick		3 m 9'10"		4.5 m 15'0"		6 m 20'0"		7.5 m 25'0"		At Max. Reach	
		Front	Side	Front	Side	Front	Side	Front	Side	Front	Side
2200 mm 7'3"	kg lb	—	—	10 200* 22,487	8450 18,629	7450* 16,424	5450 12,015	—	—	5450* 12,015	4000 8818
2500 mm 8'2"	kg lb	—	—	10 250* 22,597	8450 18,629	7450* 16,424	5450 12,015	5750* 12,677	3950 8708	4100* 9039	3800 8378
2800 mm 9'2"	kg lb	—	—	10 200* 22,487	8450 18,629	7400* 16,314	5450 12,015	5750* 12,677	3900 8598	3500* 7716	3500* 7716

*Indicates that the load is limited by hydraulic lifting capacity rather than tipping load.

NOTE: Oscillating axle needs to be locked. Weight of all lifting accessories must be subtracted from the lifting capacities.

All lift capacities calculated and rated per ISO 10567:2007. Rated loads do not exceed 87% of hydraulic lift capacity or 75% of tipping load.

Lifting capacities are based on the machine standing on a firm uniform supporting surface. The load point is the center line of the bucket pivot mounting pin on the stick.

Hydraulic Excavators

Lifting Capacity At Ground Level

- M320F ● One-Piece Boom
- 4200 kg (9259 lb) Counterweight

M320F ● Rear Dozer Up

Stick		3 m 9'10"		4.5 m 15'0"		6 m 20'0"		7.5 m 25'0"		At Max. Reach	
		Rear	Side	Rear	Side	Rear	Side	Rear	Side	Rear	Side
2200 mm	kg	—	—	4850	4150	3250	2850	—	—	2450	2150
7'3"	lb	—	—	10,692	9149	7165	6283	—	—	5401	4740
2500 mm	kg	—	—	4850	4150	3250	2850	2400	2100	2300	2000
8'2"	lb	—	—	10,692	9149	7165	6283	5291	4630	5071	4409
2800 mm	kg	—	—	4850	4150	3250	2800	2400	2050	2150	1900
9'2"	lb	—	—	10,692	9149	7165	6173	5291	4519	4740	4189

M320F ● Rear Dozer Up

Stick		3 m 9'10"		4.5 m 15'0"		6 m 20'0"		7.5 m 25'0"		At Max. Reach	
		Front	Side	Front	Side	Front	Side	Front	Side	Front	Side
2200 mm	kg	—	—	7150	4150	4750	2850	—	—	3550	2150
7'3"	lb	—	—	15,763	9149	10,472	6283	—	—	7826	4740
2500 mm	kg	—	—	7200	4150	4750	2850	3450	2100	3300	2000
8'2"	lb	—	—	15,873	9149	10,472	6283	7606	4630	7275	4409
2800 mm	kg	—	—	7200	4150	4700	2800	3450	2050	3150	1900
9'2"	lb	—	—	15,873	9149	10,362	6173	7606	4519	6945	4189

M320F ● Rear Dozer Down

Stick		3 m 9'10"		4.5 m 15'0"		6 m 20'0"		7.5 m 25'0"		At Max. Reach	
		Rear	Side	Rear	Side	Rear	Side	Rear	Side	Rear	Side
2200 mm	kg	—	—	10 200*	4800	7350	3250	—	—	5300	2450
7'3"	lb	—	—	22,487	10,582	16,204	7165	—	—	11,684	5401
2500 mm	kg	—	—	10 250*	4850	7350	3250	5200	2400	4100*	2300
8'2"	lb	—	—	22,597	10,692	16,204	7165	11,464	5291	9039	5071
2800 mm	kg	—	—	10 200*	4850	7350	3250	5200	2400	3500*	2200
9'2"	lb	—	—	22,487	10,692	16,204	7165	11,464	5291	7716	4850

M320F ● Front Dozer and Rear Stabilizer Down

Stick		3 m 9'10"		4.5 m 15'0"		6 m 20'0"		7.5 m 25'0"		At Max. Reach	
		Rear	Side	Rear	Side	Rear	Side	Rear	Side	Rear	Side
2200 mm	kg	—	—	10 200*	7550	7350	4950	—	—	5350	3700
7'3"	lb	—	—	22,487	16,645	16,204	10,913	—	—	11,795	8157
2500 mm	kg	—	—	10 250*	7600	7350	4950	5250	3600	4100*	3500
8'2"	lb	—	—	22,597	16,755	16,204	10,913	11,574	7937	9039	7716
2800 mm	kg	—	—	10 200*	7600	7350	4950	5250	3600	3500*	3300
9'2"	lb	—	—	22,487	16,755	16,204	10,913	11,574	7937	7716	7275

M320F ● 4-Point Stabilizer Down

Stick		3 m 9'10"		4.5 m 15'0"		6 m 20'0"		7.5 m 25'0"		At Max. Reach	
		Front	Side	Front	Side	Front	Side	Front	Side	Front	Side
2200 mm	kg	—	—	10 200*	8950	7450*	5750	—	—	5450*	4300
7'3"	lb	—	—	22,487	19,731	16,424	12,677	—	—	12,015	9480
2500 mm	kg	—	—	10 250*	8950	7450*	5750	5750*	4200	4100*	4000
8'2"	lb	—	—	22,597	19,731	16,424	12,677	12,677	9259	9039	8818
2800 mm	kg	—	—	10 200*	8950	7400*	5750	5750*	4150	3500*	3500*
9'2"	lb	—	—	22,487	19,731	16,314	12,677	12,677	9149	7716	7716

*Indicates that the load is limited by hydraulic lifting capacity rather than tipping load.

NOTE: Oscillating axle needs to be locked. Weight of all lifting accessories must be subtracted from the lifting capacities.

All lift capacities calculated and rated per ISO 10567:2007. Rated loads do not exceed 87% of hydraulic lift capacity or 75% of tipping load.

Lifting capacities are based on the machine standing on a firm uniform supporting surface. The load point is the center line of the bucket pivot mounting pin on the stick.

- M320F ● Hydraulically Adjustable Boom
- 3700 kg (8157 lb) Counterweight

Hydraulic Excavators

M320F ● Rear Dozer Up

Stick		3 m 9'10"		4.5 m 15'0"		6 m 20'0"		7.5 m 25'0"		At Max. Reach	
		Rear	Side	Rear	Side	Rear	Side	Rear	Side	Rear	Side
2200 mm 7'3"	kg lb	—	—	4450 9811	3750 8267	3000 6614	2550 5622	—	—	2250 4960	1950 4299
2500 mm 8'2"	kg lb	—	—	4450 9811	3750 8267	3000 6614	2550 5622	2200 4850	1850 4079	2100 4630	1800 3968
2800 mm 9'2"	kg lb	—	—	4450 9811	3750 8267	3000 6614	2550 5622	2150 4740	1850 4079	2000 4409	1700 3748

M320F ● Rear Dozer Up

Stick		3 m 9'10"		4.5 m 15'0"		6 m 20'0"		7.5 m 25'0"		At Max. Reach	
		Front	Side	Front	Side	Front	Side	Front	Side	Front	Side
2200 mm 7'3"	kg lb	—	—	6700 14,771	3750 8267	4400 9700	2550 5622	—	—	3300 7275	1950 4299
2500 mm 8'2"	kg lb	—	—	6750 14,881	3750 8267	4450 9811	2550 5622	3250 7165	1850 4079	3100 6834	1800 3968
2800 mm 9'2"	kg lb	—	—	6750 14,881	3750 8267	4400 9700	2550 5622	3200 7055	1850 4079	2950 6504	1700 3748

M320F ● Rear Dozer Down

Stick		3 m 9'10"		4.5 m 15'0"		6 m 20'0"		7.5 m 25'0"		At Max. Reach	
		Rear	Side	Rear	Side	Rear	Side	Rear	Side	Rear	Side
2200 mm 7'3"	kg lb	—	—	10 050* 22,156	4400 9700	7000 15,432	3000 6614	—	—	5000* 11,023	2250 4960
2500 mm 8'2"	kg lb	—	—	10 100* 22,267	4450 9811	7000 15,432	3000 6614	4950 10,913	2200 4850	3700* 8157	2100 4630
2800 mm 9'2"	kg lb	—	—	10 100* 22,267	4450 9811	7000 15,432	3000 6614	4900 10,803	2150 4740	3200* 7055	2000 4409

M320F ● Front Dozer and Rear Stabilizer Down

Stick		3 m 9'10"		4.5 m 15'0"		6 m 20'0"		7.5 m 25'0"		At Max. Reach	
		Rear	Side	Rear	Side	Rear	Side	Rear	Side	Rear	Side
2200 mm 7'3"	kg lb	—	—	10 050* 22,156	7100 15,653	7000 15,432	4650 10,251	—	—	5000* 11,023	3500 7716
2500 mm 8'2"	kg lb	—	—	10 100* 22,267	7100 15,653	7000 15,432	4650 10,251	5000 11,023	3400 7496	3700* 8157	3250 7165
2800 mm 9'2"	kg lb	—	—	10 100* 22,267	7150 15,763	7000 15,432	4650 10,251	5000 11,023	3350 7385	3200* 7055	3100 6834

M320F ● 4-Point Stabilizer Down

Stick		3 m 9'10"		4.5 m 15'0"		6 m 20'0"		7.5 m 25'0"		At Max. Reach	
		Front	Side	Front	Side	Front	Side	Front	Side	Front	Side
2200 mm 7'3"	kg lb	—	—	10 050* 22,156	8450 18,629	7350* 16,204	5450 12,015	—	—	5000* 11,023	4050 8929
2500 mm 8'2"	kg lb	—	—	10 100* 22,267	8500 18,739	7350* 16,204	5450 12,015	5600* 12,346	3950 8708	3700* 8157	3700* 8157
2800 mm 9'2"	kg lb	—	—	10 100* 22,267	8500 18,739	7350* 16,204	5450 12,015	5650* 12,456	3950 8708	3200* 7055	3200* 7055

*Indicates that the load is limited by hydraulic lifting capacity rather than tipping load.

NOTE: Oscillating axle needs to be locked. Weight of all lifting accessories must be subtracted from the lifting capacities.

All lift capacities calculated and rated per ISO 10567:2007. Rated loads do not exceed 87% of hydraulic lift capacity or 75% of tipping load.

Lifting capacities are based on the machine standing on a firm uniform supporting surface. The load point is the center line of the bucket pivot mounting pin on the stick.

Hydraulic Excavators

Lifting Capacity At Ground Level

- M320F ● Hydraulically Adjustable Boom
- 4200 kg (9259 lb) Counterweight

M320F ● Rear Dozer Up

Stick		3 m 9'10"		4.5 m 15'0"		6 m 20'0"		7.5 m 25'0"		At Max. Reach	
		Rear	Side	Rear	Side	Rear	Side	Rear	Side	Rear	Side
2200 mm	kg	—	—	4800	4100	3250	2800	—	—	2450	2100
7'3"	lb	—	—	10,582	9039	7165	6173	—	—	5401	4630
2500 mm	kg	—	—	4850	4100	3250	2800	2400	2050	2300	2000
8'2"	lb	—	—	10,692	9039	7165	6173	5291	4519	5071	4409
2800 mm	kg	—	—	4850	4100	3250	2800	2350	2050	2150	1850
9'2"	lb	—	—	10,692	9039	7165	6173	5181	4519	4740	4079

M320F ● Rear Dozer Up

Stick		3 m 9'10"		4.5 m 15'0"		6 m 20'0"		7.5 m 25'0"		At Max. Reach	
		Front	Side	Front	Side	Front	Side	Front	Side	Front	Side
2200 mm	kg	—	—	7150	4100	4750	2800	—	—	3550	2100
7'3"	lb	—	—	15,763	9039	10,472	6173	—	—	7826	4630
2500 mm	kg	—	—	7200	4100	4750	2800	3450	2050	3350	2000
8'2"	lb	—	—	15,873	9039	10,472	6173	7606	4519	7385	4409
2800 mm	kg	—	—	7200	4100	4750	2800	3450	2050	3150	1850
9'2"	lb	—	—	15,873	9039	10,472	6173	7606	4519	6945	4079

M320F ● Rear Dozer Down

Stick		3 m 9'10"		4.5 m 15'0"		6 m 20'0"		7.5 m 25'0"		At Max. Reach	
		Rear	Side	Rear	Side	Rear	Side	Rear	Side	Rear	Side
2200 mm	kg	—	—	10 050*	4800	7350*	3250	—	—	5000*	2450
7'3"	lb	—	—	22,156	10,582	16,204	7165	—	—	11,023	5401
2500 mm	kg	—	—	10 100*	4800	7350*	3250	5250	2400	3700*	2300
8'2"	lb	—	—	22,267	10,582	16,204	7165	11,574	5291	8157	5071
2800 mm	kg	—	—	10 100*	4800	7350*	3250	5200	2350	3200*	2150
9'2"	lb	—	—	22,267	10,582	16,204	7165	11,464	5181	7055	4740

M320F ● Front Dozer and Rear Stabilizer Down

Stick		3 m 9'10"		4.5 m 15'0"		6 m 20'0"		7.5 m 25'0"		At Max. Reach	
		Rear	Side	Rear	Side	Rear	Side	Rear	Side	Rear	Side
2200 mm	kg	—	—	10 050*	7550	7350*	4950	—	—	5000*	3700
7'3"	lb	—	—	22,156	16,645	16,204	10,913	—	—	11,023	8157
2500 mm	kg	—	—	10 100*	7600	7350*	4950	5300	3600	3700*	3500
8'2"	lb	—	—	22,267	16,755	16,204	10,913	11,684	7937	8157	7716
2800 mm	kg	—	—	10 100*	7600	7350*	4950	5250	3600	3200*	3200*
9'2"	lb	—	—	22,267	16,755	16,204	10,913	11,574	7937	7055	7055

M320F ● 4-Point Stabilizer Down

Stick		3 m 9'10"		4.5 m 15'0"		6 m 20'0"		7.5 m 25'0"		At Max. Reach	
		Front	Side	Front	Side	Front	Side	Front	Side	Front	Side
2200 mm	kg	—	—	10 050*	9000	7350*	5800	—	—	5000*	4300
7'3"	lb	—	—	22,156	19,842	16,204	12,787	—	—	11,023	9480
2500 mm	kg	—	—	10 100*	9000	7350*	5800	5600*	4200	3700*	3700*
8'2"	lb	—	—	22,267	19,842	16,204	12,787	12,346	9259	8157	8157
2800 mm	kg	—	—	10 100*	9000	7350*	5800	5650*	4200	3200*	3200*
9'2"	lb	—	—	22,267	19,842	16,204	12,787	12,456	9259	7055	7055

*Indicates that the load is limited by hydraulic lifting capacity rather than tipping load.

NOTE: Oscillating axle needs to be locked. Weight of all lifting accessories must be subtracted from the lifting capacities.

All lift capacities calculated and rated per ISO 10567:2007. Rated loads do not exceed 87% of hydraulic lift capacity or 75% of tipping load.

Lifting capacities are based on the machine standing on a firm uniform supporting surface. The load point is the center line of the bucket pivot mounting pin on the stick.

South America

320D2 ● Reach Boom ● 600 mm (24") Track Shoes

Stick	Bucket		3 m 9'10"		4.5 m 15'0"		6 m 20'0"		7.5 m 25'0"		9 m 30'0"		At Max. Reach	
			Front	Side	Front	Side	Front	Side	Front	Side	Front	Side	Front	Side
2500 mm	0.9 m ³	kg	5850*	5850*	8800	5350	5600	3500	3950	2500	—	—	3050*	1900
8'2"	1.18 yd ³	lb	13,450*	13,450	18,850	11,450	11,950	7500	8450	5300	—	—	6700*	4150
2900 mm	0.8 m ³	kg	6600*	6600*	8900	5400	5600	3550	3950	2500	—	—	2650*	1800
9'6"	1.05 yd ³	lb	15,050*	15,050*	19,050	11,600	12,050	7600	8500	5350	—	—	5750*	3900
3900 mm	0.8 m ³	kg	7900*	7900*	8850	5400	5550	3450	3900	2400	2850	1700	1800*	1400
12'10"	1.05 yd ³	lb	18,100*	18,100*	19,000	11,550	11,900	7400	8300	5100	6100	3650	3950*	3050

320D2 ● Mass Boom ● 600 mm (24") Track Shoes

Stick	Bucket		3 m 9'10"		4.5 m 15'0"		6 m 20'0"		7.5 m 25'0"		9 m 30'0"		At Max. Reach	
			Front	Side	Front	Side	Front	Side	Front	Side	Front	Side	Front	Side
2400 mm	1.1 m ³	kg	8850*	8850*	8600	5100	5350	3250	3700	2200	—	—	3150	1850
7'10"	1.44 yd ³	lb	20,350*	20,350*	18,400	10,950	11,450	6950	—	—	—	—	6950	4100

Asia Pacific

320D2 ● Heavy Duty Boom ● 790 mm (31") Track Shoes

Stick	Bucket		3 m 9'10"		4.5 m 15'0"		6 m 20'0"		7.5 m 25'0"		9 m 30'0"		At Max. Reach	
			Front	Side	Front	Side	Front	Side	Front	Side	Front	Side	Front	Side
2400 mm	0.9 m ³	kg	6250*	6250*	8800	5200	5550	3400	3900	2350	—	—	2450*	1650
7'10"	1.2 yd ³	lb	14,350*	14,350*	18,850	11,200	11,850	7250	8300	5000	—	—	5350*	3600

South America, Middle East, Africa, CIS, Asia Pacific, China

320D2 GC ● 600 mm (24") Track Shoes ● Reach Boom ● No Bucket

Stick			3 m 9'10"		4.5 m 15'0"		6 m 20'0"		7.5 m 25'0"		9 m 30'0"		At Max. Reach	
			Front	Side	Front	Side	Front	Side	Front	Side	Front	Side	Front	Side
2900 mm		kg	6200*	6200*	8900	5550	5800	3750	4150	2750	—	—	3700	2450
9'6"		lb	14,300*	14,300*	19,150	11,950	12,400	8050	9000	5900	—	—	8100	5350

320D2 GC ● 790 mm (31") Track Shoes ● Reach Boom ● No Bucket

Stick			3 m 9'10"		4.5 m 15'0"		6 m 20'0"		7.5 m 25'0"		9 m 30'0"		At Max. Reach	
			Front	Side	Front	Side	Front	Side	Front	Side	Front	Side	Front	Side
2900 mm		kg	6200*	6200*	9200	5700	5950	3850	4350	2850	—	—	3800	2500
9'6"		lb	14,300*	14,300*	19,700	12,300	12,800	8350	9300	6150	—	—	8350	5500

*Load limited by hydraulic capacity rather than tipping.

Europe, Middle East, Africa, CIS

320D2 L ● Reach Boom ● 600 mm (24") Track Shoes ● with Quick Coupler

Stick		3 m 9'10"		4.5 m 15'0"		6 m 20'0"		7.5 m 25'0"		9 m 30'0"		At Max. Reach	
		Front	Side	Front	Side	Front	Side	Front	Side	Front	Side	Front	Side
2500 mm	kg	5950*	5950*	10 450*	6350	7000	4250	5000	3100	—	—	4250*	2700
8'2"	lb	—	—	—	—	—	—	—	—	—	—	—	—
2900 mm	kg	6700*	6700*	10 250*	6400	7000	4250	5000	3100	—	—	3500*	2550
9'6"	lb	—	—	—	—	—	—	—	—	—	—	—	—

Asia Pacific

320D2 L ● Reach Boom ● 600 mm (24") Track Shoes

Stick	Bucket		3 m 9'10"		4.5 m 15'0"		6 m 20'0"		7.5 m 25'0"		9 m 30'0"		At Max. Reach	
			Front	Side	Front	Side	Front	Side	Front	Side	Front	Side	Front	Side
2500 mm	0.9 m ³	kg	—	—	10 700*	6700	7350	4500	5300	3300	—	—	5000	3100
8'2"	1.2 yd ³	lb	—	—	23,150*	14,350	15,800	9650	11,450	7150	—	—	10,950	6850
2900 mm	0.9 m ³	kg	6350*	6350*	10 550	6700	7400	4500	5300	3300	—	—	4350*	2900
9'6"	1.2 yd ³	lb	14,600*	14,600*	22,850*	14,450	15,850	9700	11,400	7100	—	—	9550*	6350

320D2 L ● Reach Boom ● 790 mm (31") Track Shoes

Stick	Bucket		3 m 9'10"		4.5 m 15'0"		6 m 20'0"		7.5 m 25'0"		9 m 30'0"		At Max. Reach	
			Front	Side	Front	Side	Front	Side	Front	Side	Front	Side	Front	Side
1900 mm	B1-1470X	kg	—	—	9700*	5700	6550	3700	4600	2600	—	—	3900	2200
6'3"	4'10"	lb	—	—	20,900*	12,250	14,000	7900	—	—	—	—	8600	4800
2500 mm	B1-1280X	kg	—	—	10,700*	6850	7550	4600	5450	3400	—	—	5100	3200
8'2"	4'2"	lb	—	—	23,150*	14,800	16,250	9950	11,750	7350	—	—	11,250	7050
2900 mm	B1-1220X	kg	6350*	6350*	10 550	6900	7600	4650	5450	3400	—	—	4350*	3000
9'6"	4'0"	lb	14,600*	14,600*	22,850*	14,850	16,300	9950	11,750	7300	—	—	9550*	6550
3900 mm	B1-1100X	kg	7650*	7650*	9100*	6300	6550*	4050	4850	2850	3600	2100	1750*	1700
12'10"	3'7"	lb	17,550*	17,550*	19,650*	13,550	14,100*	8700	10,350	6100	7650	4400	3800*	3700

320D2 L ● Mass Boom ● 800 mm (32") Track Shoes

Stick	Bucket		3 m 9'10"		4.5 m 15'0"		6 m 20'0"		7.5 m 25'0"		9 m 30'0"		At Max. Reach	
			Front	Side	Front	Side	Front	Side	Front	Side	Front	Side	Front	Side
2400 mm	CB2-1470X	kg	8550*	8550*	9700*	6000	6700	3800	4600	2600	—	—	3900*	2250
7'10"	4'10"	lb	19,650*	19,650*	21,000*	12,850	14,300	8150	—	—	—	—	8600*	4900

*Load limited by hydraulic capacity rather than tipping.

Europe

320E L ● 600 mm (24") Track Shoes ● 5.7 m HD Boom ● No Bucket
● Heavy Lift Mode On ● 5.4 mt Counterweight

Stick		3 m 9'10"		4.5 m 15'0"		6 m 20'0"		7.5 m 25'0"		9 m 30'0"		At Max. Reach	
		Front	Side	Front	Side	Front	Side	Front	Side	Front	Side	Front	Side
2.9 m	kg	6550*	6550*	12 650*	8450	8950	5700	6450	4200	—	—	4600*	3700
9'6"	lb	15,000	15,000	27,350	18,200	19,200	12,250	13,900	9050	—	—	10,100	8150

320E L ● 600 mm (24") Track Shoes ● HD Boom ● No Bucket ● 3.55 mt Counterweight

Stick		3 m 9'10"		4.5 m 15'0"		6 m 20'0"		7.5 m 25'0"		9 m 30'0"		At Max. Reach	
		Front	Side	Front	Side	Front	Side	Front	Side	Front	Side	Front	Side
2.5 m	kg	—	—	11 450	6700	7250	4500	5250	3350	—	—	4950	3150
8'2"	lb	—	—	25,240	14,770	15,980	9920	11,570	7390	—	—	10,910	6940

320E L ● 700 mm (28") Track Shoes ● HD Boom ● No Bucket ● 3.55 mt Counterweight

Stick		3 m 9'10"		4.5 m 15'0"		6 m 20'0"		7.5 m 25'0"		9 m 30'0"		At Max. Reach	
		Front	Side	Front	Side	Front	Side	Front	Side	Front	Side	Front	Side
2.9 m	kg	6600*	6600*	11 650*	6850	7400	4600	5350	3400	—	—	4650*	3000
9'6"	lb	—	—	—	—	—	—	—	—	—	—	—	—

320E L ● 790 mm (31") Track Shoes ● SLR Boom ● No Bucket
● Heavy Lift Mode On ● 4.6 mt Counterweight

Stick		3 m 9'10"		4.5 m 15'0"		6 m 20'0"		7.5 m 25'0"		9 m 30'0"		10.5 m 35'0"	
		Front	Side	Front	Side	Front	Side	Front	Side	Front	Side	Front	Side
6.28 m	kg	2000	2000	4650	4650	5750	4150	4450	3150	3650	2450	3100	1950
20'6"	lb	—	—	—	—	—	—	—	—	—	—	—	—

Stick		12 m 40'0"		13.5 m 45'0"		15 m 50'0"		16.5 m 55'0"		18 m 60'0"		At Max. Reach	
		Front	Side	Front	Side	Front	Side	Front	Side	Front	Side	Front	Side
6.28 m	kg	2700	1600	2250	1300	—	—	—	—	—	—	1250	1150
20'6"	lb	—	—	—	—	—	—	—	—	—	—	—	—

*Load limited by hydraulic capacity rather than tipping.

North America

320E LRR ● 790 mm (31") Track Shoes ● HD Boom ● No Bucket
● Heavy Lift Mode On ● 6.2 mt Counterweight

Stick		3 m 9'10"		4.5 m 15'0"		6 m 20'0"		7.5 m 25'0"		9 m 30'0"		At Max. Reach	
		Front	Side	Front	Side	Front	Side	Front	Side	Front	Side	Front	Side
2.9 m	kg	6600*	6600*	11 650*	7450	8150	5050	5900	3750	—	—	4650*	3300
9'6"	lb	15,150	15,150	25,200	16,050	17,550	10,800	12,700	8000	—	—	10,250	7200

320E LRR ● 790 mm (31") Track Shoes ● HD Boom ● No Bucket
● Heavy Lift Mode On ● 6.9 mt Counterweight

Stick		3 m 9'10"		4.5 m 15'0"		6 m 20'0"		7.5 m 25'0"		9 m 30'0"		At Max. Reach	
		Front	Side	Front	Side	Front	Side	Front	Side	Front	Side	Front	Side
2.9 m	kg	6600*	6600*	11 650	7950	8500*	5350	6250	4000	—	—	4650*	3500
9'6"	lb	15,150	15,150	25,200	17,100	18,400	11,550	13,450	8550	—	—	10,250	7700

320E LRR ● 790 mm (31") Track Shoes ● ES Boom ● No Bucket
● Heavy Lift Mode On ● 6.9 mt Counterweight

Stick		3 m 9'10"		4.5 m 15'0"		6 m 20'0"		7.5 m 25'0"		9 m 30'0"		At Max. Reach	
		Front	Side	Front	Side	Front	Side	Front	Side	Front	Side	Front	Side
2.9 m	kg	6550*	6550*	11 300*	7700	8250*	5150	6100	3800	—	—	4600*	3350
9'6"	lb	15,000	15,000	24,450	16,550	17,850	11,100	13,100	8200	—	—	10,100	7350

Europe

320E LRR ● 700 mm (28") Track Shoes ● HD Boom ● No Bucket ● 6.2 mt Counterweight

Stick		3 m 9'10"		4.5 m 15'0"		6 m 20'0"		7.5 m 25'0"		9 m 30'0"		At Max. Reach	
		Front	Side	Front	Side	Front	Side	Front	Side	Front	Side	Front	Side
2.9 m	kg	6600*	6600*	11 650*	7400	8100	5000	5850	3700	—	—	4650*	3250
9'6"	lb	—	—	—	—	—	—	—	—	—	—	—	—

North America

320F L ● 790 mm (31") Track Shoes

Stick		3 m 9'10"		4.5 m 15'0"		6 m 20'0"		7.5 m 25'0"		9 m 30'0"		At Max. Reach	
		Front	Side	Front	Side	Front	Side	Front	Side	Front	Side	Front	Side
2.9 m	kg	6600*	6600*	11 500*	6800	7400	4550	5350	3400	—	—	4650	2950
9'6"	lb	15,150*	15,150*	24,900*	14,600	15,900	9850	11,500	7250	—	—	10,250	6500

*Load limited by hydraulic capacity rather than tipping.

South America

323D2 L ● Reach Boom ● 700 mm (28") Track Shoes

Stick	Bucket	3 m 9'10"		4.5 m 15'0"		6 m 20'0"		7.5 m 25'0"		9 m 30'0"		At Max. Reach		
		Front	Side	Front	Side	Front	Side	Front	Side	Front	Side	Front	Side	
2.5 m	1.2 m ³	kg	—	—	7450*	6250	6850	3950	4800	2750	—	—	2700*	2050
8'2"	1.60 yd ³	lb	—	—	—	—	—	—	—	—	—	—	—	—

323D2 L ● Mass Boom ● 600 mm (24") Track Shoes

Stick	Bucket	3 m 9'10"		4.5 m 15'0"		6 m 20'0"		7.5 m 25'0"		9 m 30'0"		At Max. Reach		
		Front	Side	Front	Side	Front	Side	Front	Side	Front	Side	Front	Side	
2.4 m	1.2 m ³	kg	—	—	7900*	6100	6650	3800	4600	2600	—	—	4250	2400
7'9"	1.60 yd ³	lb	—	—	—	—	—	—	—	—	—	—	—	—

Asia Pacific

323D2 L ● Reach Boom ● 600 mm (24") Track Shoes

Stick		3 m 9'10"		4.5 m 15'0"		6 m 20'0"		7.5 m 25'0"		9 m 30'0"		At Max. Reach	
		Front	Side	Front	Side	Front	Side	Front	Side	Front	Side	Front	Side
2.9 m	kg	6350	6350	10 750	6950	7450	4600	5350	3400	—	—	4350	2950
9'6"	lb	14,600	14,600	23,300	14,800	16,000	9900	11,550	7300	—	—	9550	6550

7

Europe, Middle East, Africa, CIS

323D2 L ● Reach Boom ● 600 mm (24") Track Shoes

Stick		3 m 9'10"		4.5 m 15'0"		6 m 20'0"		7.5 m 25'0"		9 m 30'0"		At Max. Reach	
		Front	Side	Front	Side	Front	Side	Front	Side	Front	Side	Front	Side
2.5 m	kg	—	—	10 700	6700	7350	4500	5300	3300	—	—	5000	3100
8'2"	lb	—	—	23,150	14,350	15,800	9650	11,450	7150	—	—	10,950	6850
2.9 m	kg	6350	6350	10 550	6700	7400	4500	5300	3300	—	—	4350	2900
9'6"	lb	14,600	14,600	22,850	14,450	15,850	9700	11,400	9100	—	—	9550	6350

*Load limited by hydraulic capacity rather than tipping.

Europe

323E LN ● 500 mm (20") Track Shoes ● HL Reach Boom ● No Bucket ● Heavy Lift Mode On

Stick		1.5 m 5'0"		3 m 9'10"		4.5 m 15'0"		6 m 20'0"		7.5 m 25'0"		At Max. Reach	
		Front	Side	Front	Side	Front	Side	Front	Side	Front	Side	Front	Side
2.5 m	kg	—	—	—	—	11 450*	6100	8050	4200	5800	3100	5450	2900
8'2"	lb	—	—	—	—	24,800*	13,150	17,350	9000	12,550	6700	12,020	6390

323E LN ● 500 mm (20") Track Shoes ● VA Boom ● No Bucket

Stick		1.5 m 5'0"		3 m 9'10"		4.5 m 15'0"		6 m 20'0"		7.5 m 25'0"		At Max. Reach	
		Front	Side	Front	Side	Front	Side	Front	Side	Front	Side	Front	Side
2.5 m	kg	9650*	9650*	6350*	6350*	10 100*	5900	6800*	4050	5800	3000	5100	2650
8'2"	lb	20,900*	20,900*	14,100	14,100	21,700*	12,700	14,650*	8700	12,300*	6450	11,240	5840

323E LN ● 500 mm (20") Track Shoes ● HD Reach Boom ● No Bucket ● Heavy Lift Mode On

Stick		1.5 m 5'0"		3 m 9'10"		4.5 m 15'0"		6 m 20'0"		7.5 m 25'0"		At Max. Reach	
		Front	Side	Front	Side	Front	Side	Front	Side	Front	Side	Front	Side
2.5 m	kg	—	—	—	—	11 300*	6000	8000	4100	5750	3050	5400	2850
8'2"	lb	—	—	—	—	24,400*	12,900	17,150	8800	12,400	6500	11,900	6280

323E SA ● 550 mm (22") Track Shoes ● HD Reach Boom ● No Bucket ● Heavy Lift Mode On

Stick		1.5 m 5'0"		3 m 9'10"		4.5 m 15'0"		6 m 20'0"		7.5 m 25'0"		At Max. Reach	
		Front	Side	Front	Side	Front	Side	Front	Side	Front	Side	Front	Side
2.5 m	kg	—	—	—	—	11 450*	6200	8050	4250	5850	3150	5500	3000
8'2"	lb	—	—	—	—	—	—	—	—	—	—	—	—

323E SA ● 550 mm (22") Track Shoes ● ES Reach Boom ● No Bucket ● Heavy Lift Mode On

Stick		1.5 m 5'0"		3 m 9'10"		4.5 m 15'0"		6 m 20'0"		7.5 m 25'0"		At Max. Reach	
		Front	Side	Front	Side	Front	Side	Front	Side	Front	Side	Front	Side
2.5 m	kg	—	—	—	—	11 300*	6050	7950	4150	5750	3100	5450	2900
8'2"	lb	—	—	—	—	—	—	—	—	—	—	—	—

323E SA ● 550 mm (22") Track Shoes ● HD Reach Boom ● No Bucket ● Heavy Lift Mode On

Stick		1.5 m 5'0"		3 m 9'10"		4.5 m 15'0"		6 m 20'0"		7.5 m 25'0"		At Max. Reach	
		Front	Side	Front	Side	Front	Side	Front	Side	Front	Side	Front	Side
2.9 m	kg	—	—	6750*	6750*	11 300*	6200	8000	4250	5800	3150	4650*	2750
9'6"	lb	—	—	—	—	—	—	—	—	—	—	—	—

323E SA ● 550 mm (22") Track Shoes ● HD Reach Boom ● No Bucket ● Heavy Lift Mode On

Stick		1.5 m 5'0"		3 m 9'10"		4.5 m 15'0"		6 m 20'0"		7.5 m 25'0"		At Max. Reach	
		Front	Side	Front	Side	Front	Side	Front	Side	Front	Side	Front	Side
1.9 m	kg	—	—	—	—	11 350*	6050	7950	4150	—	—	6050	3250
6'3"	lb	—	—	—	—	—	—	—	—	—	—	—	—

323E SA ● 550 mm (22") Track Shoes ● VA Boom ● No Bucket ● Heavy Lift Mode On

Stick		1.5 m 5'0"		3 m 9'10"		4.5 m 15'0"		6 m 20'0"		7.5 m 25'0"		At Max. Reach	
		Front	Side	Front	Side	Front	Side	Front	Side	Front	Side	Front	Side
2.5 m	kg	9600*	9600*	6400*	6400*	10 250*	6000	6850*	4100	5800	3050	5150*	2750
8'2"	lb	—	—	—	—	—	—	—	—	—	—	—	—

*Load limited by hydraulic capacity rather than tipping.

North America

323F L ● 790 mm (31") Track Shoes ● 5.7 m Boom ● No Bucket
● Heavy Lift Mode On ● 4.1 mt Counterweight

Stick		3 m 9'10"		4.5 m 15'0"		6 m 20'0"		7.5 m 25'0"		9 m 30'0"		At Max. Reach	
		Front	Side	Front	Side	Front	Side	Front	Side	Front	Side	Front	Side
2900 mm	kg	6600*	6600*	11 650*	7550	8050	5050	5850	3750	—	—	4650*	3300
9'6"	lb	15,150*	15,150*	25,250*	16,250	17,350	10,900	12,550	8100	—	—	10,250*	7250

Japan

324E ● Reach Boom ● 600 mm (24") Track Shoes

Stick		3 m 9'10"		4.5 m 15'0"		6 m 20'0"		7.5 m 25'0"		9 m 30'0"		At Max. Reach	
		Front	Side	Front	Side	Front	Side	Front	Side	Front	Side	Front	Side
2500 mm	kg	—	—	12 300	7950	7900	5350	5750	3950	—	—	5250	3650
8'2"	lb	—	—	26,450	17,050	17,000	11,500	12,400	8500	—	—	11,600	8000
2950 mm	kg	—	—	12 350	7950	7900	3530	5750	3950	—	—	4850	3350
9'8"	lb	—	—	26,450	17,100	17,000	11,450	12,350	8450	—	—	10,700	7350

324E ● Mass Boom ● 600 mm (24") Track Shoes

Stick		3 m 9'10"		4.5 m 15'0"		6 m 20'0"		7.5 m 25'0"		9 m 30'0"		At Max. Reach	
		Front	Side	Front	Side	Front	Side	Front	Side	Front	Side	Front	Side
2500 mm	kg	—	—	12 300	7900	7850	5250	—	—	—	—	5800	3950
8'2"	lb	—	—	26,400	16,950	16,900	11,300	—	—	—	—	12,750	8650

North America, Japan, Europe

324E L ● Reach Boom ● 790 mm (31") Track Shoes

Stick		3 m 9'10"		4.5 m 15'0"		6 m 20'0"		7.5 m 25'0"		9 m 30'0"		At Max. Reach	
		Front	Side	Front	Side	Front	Side	Front	Side	Front	Side	Front	Side
2500 mm	kg	—	—	15 300	9200	9600	6150	6950	4550	—	—	6300	4200
8'2"	lb	—	—	32,850	19,800	20,650	13,250	14,900	9800	—	—	13,900	9200
2950 mm	kg	—	—	15 350	9250	9600	6150	6900	4500	—	—	5850	3850
9'8"	lb	—	—	32,900	19,850	20,650	13,200	14,850	9750	—	—	12,850	8500

324E L ● Mass Boom ● 800 mm (32") Track Shoes

Stick		3 m 9'10"		4.5 m 15'0"		6 m 20'0"		7.5 m 25'0"		9 m 30'0"		At Max. Reach	
		Front	Side	Front	Side	Front	Side	Front	Side	Front	Side	Front	Side
2500 mm	kg	—	—	15 350	9200	9550	6050	—	—	—	—	7000	4550
8'2"	lb	—	—	32,850	19,750	20,550	13,050	—	—	—	—	15,400	10,000

*Load limited by hydraulic capacity rather than tipping.

Europe

324E L ● VA Boom ● 790 mm (31") Track Shoes

Stick		3 m 9'10"		4.5 m 15'0"		6 m 20'0"		7.5 m 25'0"		9 m 30'0"		At Max. Reach	
		Front	Side	Front	Side	Front	Side	Front	Side	Front	Side	Front	Side
2500 mm	kg	9450	9450	15 150	8950	9500	5950	6850	4400	—	—	6000	3900
8'2"	lb	20,850	20,850	32,450	19,200	20,450	12,850	14,750	9500	—	—	13,250	8550
2950 mm	kg	6450	6450	14 300	8950	9500	5950	6850	4400	—	—	5600	3600
9'8"	lb	14,300	14,300	30,600	19,250	20,450	12,850	14,750	9500	—	—	12,250	7900

324E L ● Reach Boom ● 600 mm (24") Track Shoes

Stick		3 m 9'10"		4.5 m 15'0"		6 m 20'0"		7.5 m 25'0"		9 m 30'0"		At Max. Reach	
		Front	Side	Front	Side	Front	Side	Front	Side	Front	Side	Front	Side
2500 mm	kg	—	—	15 050	8200	9450	5500	6800	4100	—	—	6200	3750
8'2"	lb	—	—	32,250	17,650	20,300	11,850	14,650	8800	—	—	13,650	8250
2950 mm	kg	—	—	15 100	8200	9450	5500	6800	4050	—	—	5750	3500
9'8"	lb	—	—	32,300	17,650	20,300	11,850	14,550	8750	—	—	12,650	7650

324E LN ● Mass Boom ● 600 mm (24") Track Shoes

Stick		3 m 9'10"		4.5 m 15'0"		6 m 20'0"		7.5 m 25'0"		9 m 30'0"		At Max. Reach	
		Front	Side	Front	Side	Front	Side	Front	Side	Front	Side	Front	Side
2500 mm	kg	—	—	15 100	8150	9400	5450	—	—	—	—	6850	4050
8'2"	lb	—	—	32,300	17,550	20,200	11,700	—	—	—	—	15,100	8950

324E LN ● VA Boom ● 600 mm (24") Track Shoes

Stick		1.5 m 5'0"		3 m 9'10"		4.5 m 15'0"		6 m 20'0"		7.5 m 25'0"		At Max. Reach	
		Front	Side	Front	Side	Front	Side	Front	Side	Front	Side	Front	Side
2500 mm	kg	11 150	11 150	9450	9450	14 900	7900	9350	5300	6750	3950	5900	3500
8'2"	lb	24,500	24,500	20,850	20,850	31,900	17,000	20,050	11,450	14,450	8500	13,000	7650
2950 mm	kg	7900	7900	6450	6450	14 300	7900	9350	5300	6700	3900	5450	3200
9'8"	lb	17,350	17,350	14,300	14,300	30,600	17,000	20,100	11,450	14,450	8450	12,050	7100

*Load limited by hydraulic capacity rather than tipping.

North America, Europe, Australia, New Zealand

**325F L ● 790 mm (31") Track Shoes ● 5.7 m (18'8") Reach Boom ● No Bucket
 ● Heavy Lift Mode On ● Standard Counterweight**

Stick		1.5 m 5'0"		3 m 9'10"		4.5 m 15'0"		6 m 20'0"		7.5 m 25'0"		At Max. Reach	
		Front	Side	Front	Side	Front	Side	Front	Side	Front	Side	Front	Side
2920 mm	kg	—	—	7350*	7350*	12 650	7100	8000	4800	5800	3550	4750*	3150
9'6"	lb	—	—	16,800*	16,800*	27,100	15,350	17,250	10,300	12,500	7650	10,450*	6950

**325F L ● 600 mm (24") Track Shoes ● 5.7 m (18'8") Reach Boom ● No Bucket
 ● Heavy Lift Mode On ● Standard Counterweight**

Stick		1.5 m 5'0"		3 m 9'10"		4.5 m 15'0"		6 m 20'0"		7.5 m 25'0"		At Max. Reach	
		Front	Side	Front	Side	Front	Side	Front	Side	Front	Side	Front	Side
2920 mm	kg	—	—	7350*	7350*	12 350	6950	7850	4700	5650	3450	4750*	3100
9'6"	lb	—	—	16,800*	16,800*	26,500	14,950	16,850	10,050	12,200	7450	10,450*	6800

Europe

**325F L ● 600 mm (24") Track Shoes ● VA Boom (2.8 m [9'2"] Stub + 3.3 m [10'10"] Fore)
 ● No Bucket ● Heavy Lift Mode On ● Standard Counterweight**

Stick		1.5 m 5'0"		3 m 9'10"		4.5 m 15'0"		6 m 20'0"		7.5 m 25'0"		At Max. Reach	
		Front	Side	Front	Side	Front	Side	Front	Side	Front	Side	Front	Side
2920 mm	kg	7150*	7150*	6000*	6000*	10 400*	6700	4500	4700	5600	3350	4700	2800
9'6"	lb	15,350*	15,350*	13,000*	13,000*	22,350*	14,450	9700	10,050	12,050	7200	10,300	6200

Asia Pacific

326D2 L ● Reach Boom ● 600 mm (24") Track Shoes ● No Bucket

Stick		3 m 9'10"		4.5 m 15'0"		6 m 20'0"		7.5 m 25'0"		9 m 30'0"		At Max. Reach	
		Front	Side	Front	Side	Front	Side	Front	Side	Front	Side	Front	Side
2500 mm	kg	—	—	14 200*	8950	9250	5950	6700	4400	—	—	6100	4050
8'2"	lb	—	—	30,750*	19,200	19,950	12,800	14,400	9500	—	—	13,450	8900
2950 mm	kg	—	—	14 100*	8950	9300	5950	6650	4400	—	—	5650	3750
9'8"	lb	—	—	30,450*	19,250	19,950	12,800	14,350	9450	—	—	12,450	8250

*Load limited by hydraulic capacity rather than tipping.

North America, Europe, Japan

326F L ● 790 mm (31") Track Shoes ● 5.9 m Reach Boom ● No Bucket
● Heavy Lift Mode On ● 4.0 mt Counterweight

Stick		1.5 m 5'0"		3 m 9'10"		4.5 m 15'0"		6 m 20'0"		7.5 m 25'0"		At Max. Reach	
		Front	Side	Front	Side	Front	Side	Front	Side	Front	Side	Front	Side
2500 mm	kg	—	—	—	—	15 300	9200	9600	6150	6950	4550	6300	4200
8'2"	lb	—	—	—	—	32,850	19,800	20,650	13,250	14,900	9800	13,900	9200
2950 mm	kg	—	—	—	—	15 350	9250	9600	6150	6900	4500	5850	3850
9'8"	lb	—	—	—	—	32,900	19,850	20,650	13,200	14,850	9750	12,850	8350

Europe

326F L ● 790 mm (31") Track Shoes ● VA Boom ● No Bucket
● Heavy Lift Mode On ● 4.0 mt Counterweight

Stick		1.5 m 5'0"		3 m 9'10"		4.5 m 15'0"		6 m 20'0"		7.5 m 25'0"		At Max. Reach	
		Front	Side	Front	Side	Front	Side	Front	Side	Front	Side	Front	Side
2500 mm	kg	—	—	9450*	9450*	14 950	8800	9400	5850	6750	4350	5950	3850
8'2"	lb	—	—	20,850*	20,850*	32,050	18,900	20,150	12,600	14,550	9350	13,100	8450
2950 mm	kg	7900*	7900*	6450*	6450*	14 300*	8800	9400	5850	6750	4300	5500	3550
9'8"	lb	17,350*	17,350*	14,300*	14,300*	30,600*	18,950	20,200	12,600	14,500	9250	12,100	7800

326F LN ● 600 mm (24") Track Shoes ● 5.9 m Reach Boom ● No Bucket
● Heavy Lift Mode On ● 4.0 mt Counterweight

Stick		1.5 m 5'0"		3 m 9'10"		4.5 m 15'0"		6 m 20'0"		7.5 m 25'0"		At Max. Reach	
		Front	Side	Front	Side	Front	Side	Front	Side	Front	Side	Front	Side
2500 mm	kg	—	—	—	—	14 800	8050	9250	5400	6700	4000	6100	3700
8'2"	lb	—	—	—	—	31,700	17,300	19,950	11,650	14,400	8650	13,400	8100
2950 mm	kg	—	—	—	—	14 800	8050	9300	5400	6650	4000	5650	3400
9'8"	lb	—	—	—	—	31,750	17,350	19,950	11,650	14,350	8600	12,450	7500

326F LN ● 600 mm (24") Track Shoes ● VA Boom ● No Bucket
● Heavy Lift Mode On ● 4.0 mt Counterweight

Stick		1.5 m 5'0"		3 m 9'10"		4.5 m 15'0"		6 m 20'0"		7.5 m 25'0"		At Max. Reach	
		Front	Side	Front	Side	Front	Side	Front	Side	Front	Side	Front	Side
2500 mm	kg	—	—	9450*	9450*	14 550	7700	9150	5200	6600	3850	5800	3400
8'2"	lb	—	—	20,850*	20,850*	31,200	16,550	19,650	11,150	14,150	8250	12,750	7500
2950 mm	kg	7900*	7900*	6450*	6450*	14 300*	7700	9150	5150	6550	3800	5350	3150
9'8"	lb	17,350*	17,350*	14,300*	14,300*	30,600*	16,650	19,600	11,100	14,100	8200	11,750	6850

*Load limited by hydraulic capacity rather than tipping.

Asia Pacific

329D2 ● Reach Boom ● 600 mm (24") Track Shoes ● No Bucket

Stick		3 m 9'10"		4.5 m 15'0"		6 m 20'0"		7.5 m 25'0"		9 m 30'0"		At Max. Reach	
		Front	Side	Front	Side	Front	Side	Front	Side	Front	Side	Front	Side
2650 mm	kg	—	—	13 900	8950	8850	6000	6450	4450	—	—	4500	3750
8'8"	lb	—	—	29,800	19,250	19,100	12,900	13,850	9550	—	—	11,850	8250
3200 mm	kg	—	—	13 750	8800	8750	5900	6350	4350	—	—	4900	3350
10'6"	lb	—	—	29,450	18,950	18,850	12,700	13,650	9300	—	—	10,750	7400

329D2 L ● Reach Boom ● 600 mm (24") Track Shoes ● No Bucket

Stick		3 m 9'10"		4.5 m 15'0"		6 m 20'0"		7.5 m 25'0"		9 m 30'0"		At Max. Reach	
		Front	Side	Front	Side	Front	Side	Front	Side	Front	Side	Front	Side
2650 mm	kg	—	—	16 500*	10 100	10 950	6700	7800	4950	—	—	6550	4150
8'8"	lb	—	—	35,850	21,700	23,500	14,450	16,800	10,650	—	—	14,350	9150

Japan

329E ● Reach Boom ● 600 mm (24") Track Shoes

Stick		3 m 9'10"		4.5 m 15'0"		6 m 20'0"		7.5 m 25'0"		9 m 30'0"		At Max. Reach	
		Front	Side	Front	Side	Front	Side	Front	Side	Front	Side	Front	Side
2650 mm	kg	—	—	14 350	9350	9200	6300	6700	4650	—	—	5600	3950
8'8"	lb	—	—	30,800	20,150	19,750	13,550	14,400	10,050	—	—	12,350	8700
3200 mm	kg	—	—	14 300	9300	9150	6250	6600	4600	—	—	5150	3600
10'6"	lb	—	—	30,650	20,000	19,650	13,400	14,250	9900	—	—	11,300	7900

329E ● Mass Boom ● 600 mm (24") Track Shoes

Stick		3 m 9'10"		4.5 m 15'0"		6 m 20'0"		7.5 m 25'0"		9 m 30'0"		At Max. Reach	
		Front	Side	Front	Side	Front	Side	Front	Side	Front	Side	Front	Side
2500 mm	kg	—	—	14 550	9450	9300	6350	6750	4700	—	—	6550	4550
8'2"	lb	—	—	31,200	20,350	19,950	13,600	14,500	10,050	—	—	14,450	10,050

North America, Japan, Europe

329E L ● Reach Boom ● 800 mm (32") Track Shoes

Stick		3 m 9'10"		4.5 m 15'0"		6 m 20'0"		7.5 m 25'0"		9 m 30'0"		At Max. Reach	
		Front	Side	Front	Side	Front	Side	Front	Side	Front	Side	Front	Side
2650 mm	kg	—	—	17 550*	11 350	12 150	7600	8700	5600	—	—	7300	4750
8'8"	lb	—	—	40,000*	24,450	26,100	16,350	18,750	12,100	—	—	16,050	10,450
3200 mm	kg	—	—	18 150*	11 300	12 100	7550	8650	5550	—	—	6350	4350
10'6"	lb	—	—	39,300*	24,300	26,000	16,200	18,600	11,950	—	—	14,000	9550

329E L ● Mass Boom ● 800 mm (32") Track Shoes

Stick		3 m 9'10"		4.5 m 15'0"		6 m 20'0"		7.5 m 25'0"		9 m 30'0"		At Max. Reach	
		Front	Side	Front	Side	Front	Side	Front	Side	Front	Side	Front	Side
2500 mm	kg	—	—	18 400*	11 400	12 150	7550	8700	5600	—	—	8500	5450
8'2"	lb	—	—	39,800*	24,500	26,100	16,300	18,700	12,000	—	—	18,700	12,000

*Load limited by hydraulic capacity rather than tipping.

Europe

329E L ● Reach Boom ● 600 mm (24") Track Shoes

Stick		3 m 9'10"		4.5 m 15'0"		6 m 20'0"		7.5 m 25'0"		9 m 30'0"		At Max. Reach	
		Front	Side	Front	Side	Front	Side	Front	Side	Front	Side	Front	Side
2000 mm 6'7"	kg lb	—	—	—	—	—	—	—	—	—	—	—	—
2650 mm 8'8"	kg lb	—	—	17 550* 40,000*	11 050 23,800	11 800 25,350	7350 15,850	8450 18,200	5450 11,750	—	—	7050 15,550	4600 10,150
3200 mm 10'6"	kg lb	—	—	18 150* 39,300*	11 000 23,650	11 750 25,200	7300 15,750	8400 18,050	5400 11,600	—	—	6350* 14,000*	4200 9250

329E L ● Mass Boom ● 600 mm (24") Track Shoes

Stick		3 m 9'10"		4.5 m 15'0"		6 m 20'0"		7.5 m 25'0"		9 m 30'0"		At Max. Reach	
		Front	Side	Front	Side	Front	Side	Front	Side	Front	Side	Front	Side
2500 mm 8'2"	kg lb	—	—	18 400* 39,800*	11 050 23,800	11 800 25,350	7350 15,800	8450 18,150	5400 11,650	—	—	8250 18,100	5300 11,650

329E LN ● Reach Boom ● 600 mm (24") Track Shoes

Stick		3 m 9'10"		4.5 m 15'0"		6 m 20'0"		7.5 m 25'0"		9 m 30'0"		At Max. Reach	
		Front	Side	Front	Side	Front	Side	Front	Side	Front	Side	Front	Side
2000 mm 6'7"	kg lb	—	—	—	—	—	—	—	—	—	—	—	—
2650 mm 8'8"	kg lb	—	—	17 550* 40,000*	10 050 21,650	11 800 25,400	6750 14,600	8500 18,250	5050 10,850	—	—	7100 15,600	4250 9400
3200 mm 10'6"	kg lb	—	—	18 150* 39,300*	10 000 21,500	11 750 25,300	6700 14,450	8400 18,100	4950 10,700	—	—	6350* 14,000*	3900 8550

329E LN ● Mass Boom ● 600 mm (24") Track Shoes

Stick		3 m 9'10"		4.5 m 15'0"		6 m 20'0"		7.5 m 25'0"		9 m 30'0"		At Max. Reach	
		Front	Side	Front	Side	Front	Side	Front	Side	Front	Side	Front	Side
2500 mm 8'2"	kg lb	—	—	18 400* 39,800*	10 100 21,700	11 850 25,400	6750 14,500	8450 18,200	5000 10,750	—	—	8250 18,150	4900 10,750

North America, Europe, Japan

329F L ● 800 mm (32") Track Shoes ● 6.15 m Reach Boom ● No Bucket
● Heavy Lift Mode On ● 5.8 mt Counterweight

Stick		3 m 9'10"		4.5 m 15'0"		6 m 20'0"		7.5 m 25'0"		9 m 30'0"		At Max. Reach	
		Front	Side	Front	Side	Front	Side	Front	Side	Front	Side	Front	Side
2650 mm 8'8"	kg lb	—	—	17 550* 40,000*	11 350 24,450	12 150 26,100	7600 16,350	8700 18,750	5600 12,100	—	—	7300 16,050	4750 10,450
3200 mm 10'6"	kg lb	—	—	18 150* 39,300*	11 300 24,300	12 100 26,800	7550 16,200	8650 18,600	5550 11,950	—	—	6350* 14,000	4350 9550
3750 mm 12'4"	kg lb	6500* 14,900*	6500* 14,900*	17 650* 38,150*	11 100 23,900	11 950 25,700	7350 15,850	8550 18,350	5400 11,650	6550 14,050	4200 9000	5350* 11,800*	3900 8550

*Load limited by hydraulic capacity rather than tipping.

Europe

329F L ● 600 mm (24") Track Shoes ● 6.15 m Reach Boom ● No Bucket
 ● Heavy Lift Mode On ● 5.8 mt Counterweight

Stick		3 m 9'10"		4.5 m 15'0"		6 m 20'0"		7.5 m 25'0"		9 m 30'0"		At Max. Reach	
		Front	Side	Front	Side	Front	Side	Front	Side	Front	Side	Front	Side
3200 mm	kg	—	—	17 800*	10 450	11 350	6900	8100	5100	—	—	6250	3950
10'6"	lb	—	—	38,450*	22,450	24,400	14,900	17,450	10,950	—	—	13,750	8700

South America

330D2 L ● Reach Boom ● 800 mm (32") Track Shoes ● No Bucket

Stick		3 m 9'10"		4.5 m 15'0"		6 m 20'0"		7.5 m 25'0"		9 m 30'0"		At Max. Reach	
		Front	Side	Front	Side	Front	Side	Front	Side	Front	Side	Front	Side
3200 mm	kg	—	—	16 500*	10 550	11 350	7000	8150	5150	—	—	5850*	4050
10'6"	lb	—	—	35,700*	22,650	24,450	15,100	17,500	11,100	—	—	12,800*	8850

330D2 L ● Mass Boom ● 800 mm (32") Track Shoes ● No Bucket

Stick		3 m 9'10"		4.5 m 15'0"		6 m 20'0"		7.5 m 25'0"		9 m 30'0"		At Max. Reach	
		Front	Side	Front	Side	Front	Side	Front	Side	Front	Side	Front	Side
2500 mm	kg	—	—	16 700*	10 600	11 450	7050	8200	5200	—	—	7950	5050
8'2"	lb	—	—	36,150*	22,800	24,550	15,150	17,600	11,150	—	—	17,550	11,150

Middle East, Africa

330D2 L ● Reach Boom ● 800 mm (32") Track Shoes ● No Bucket

Stick		3 m 9'10"		4.5 m 15'0"		6 m 20'0"		7.5 m 25'0"		9 m 30'0"		At Max. Reach	
		Front	Side	Front	Side	Front	Side	Front	Side	Front	Side	Front	Side
2650 mm	kg	—	—	16 600*	10 650	11 450	7100	8200	5250	—	—	6850	4450
8'8"	lb	—	—	36,450*	22,900	24,600	15,250	17,700	11,300	—	—	15,150	9750
3200 mm	kg	—	—	16 500*	10 550	11 350	7000	8150	5150	—	—	5850*	4050
10'6"	lb	—	—	35,700*	22,650	24,450	15,100	17,500	11,100	—	—	12,800*	8850

330D2 L ● Mass Boom ● 800 mm (32") Track Shoes ● No Bucket

Stick		3 m 9'10"		4.5 m 15'0"		6 m 20'0"		7.5 m 25'0"		9 m 30'0"		At Max. Reach	
		Front	Side	Front	Side	Front	Side	Front	Side	Front	Side	Front	Side
2500 mm	kg	—	—	16 700*	10 600	11 450	7050	8200	5200	—	—	7950	5050
8'2"	lb	—	—	36,150*	22,800	24,550	15,150	17,600	11,150	—	—	17,550	11,150

North America, Europe, Japan

330F L ● 800 mm (32") Track Shoes ● 6.15 m Reach Boom ● No Bucket
 ● Heavy Lift Mode On ● 5.8 mt Counterweight

Stick		3 m 9'10"		4.5 m 15'0"		6 m 20'0"		7.5 m 25'0"		9 m 30'0"		At Max. Reach	
		Front	Side	Front	Side	Front	Side	Front	Side	Front	Side	Front	Side
2650 mm	kg	—	—	17 550*						—	—	7250	4700
8'8"	lb	—	—	40,150*	24,200	25,950	16,150	18,650	11,950	—	—	15,950	10,350
3200 mm	kg	—	—	18 200*	11 150	12 000	7400	8600	5450	—	—	6400*	4300
10'6"	lb	—	—	39,400*	23,950	25,750	15,950	18,450	11,750	—	—	14,050*	9400
3750 mm	kg	6500*	6500*	17 650*	11 050	11 900	7350	8500	5400	6500	4150	5350*	3850
12'4"	lb	14,900*	14,900*	38,150*	23,750	25,600	15,800	18,300	11,550	14,000	8950	11,800*	8500

*Load limited by hydraulic capacity rather than tipping.

Hydraulic Excavators

Lifting Capacity At Ground Level

● 330F L ● 330F LN ● 335F L ● 336D2 ● 336D2 GC

Europe

330F L ● 600 mm (24") Track Shoes ● 6.15 m Reach Boom ● No Bucket
● Heavy Lift Mode On ● 5.8 mt Counterweight

Stick		3 m 9'10"		4.5 m 15'0"		6 m 20'0"		7.5 m 25'0"		9 m 30'0"		At Max. Reach	
		Front	Side	Front	Side	Front	Side	Front	Side	Front	Side	Front	Side
2650 mm	kg	—	—	17 550*	10 900	11 700	7300	8400	5400	—	—	7050	4550
8'8"	lb	—	—	40,150*	23,500	25,150	15,700	18,100	11,600	—	—	15,500	10,050
3200 mm	kg	—	—	18 200*	10 800	11 650	7200	8350	5300	—	—	6400*	4150
10'6"	lb	—	—	39,400*	23,250	25,000	15,500	17,900	11,400	—	—	14,050*	9100

330F LN ● 600 mm (24") Track Shoes ● 6.15 m Reach Boom ● No Bucket
● Heavy Lift Mode On ● 5.8 mt Counterweight

Stick		3 m 9'10"		4.5 m 15'0"		6 m 20'0"		7.5 m 25'0"		9 m 30'0"		At Max. Reach	
		Front	Side	Front	Side	Front	Side	Front	Side	Front	Side	Front	Side
2650 mm	kg	—	—	17 550*	9950	11 650	6700	8350	4950	—	—	7000	4200
8'8"	lb	—	—	40,150*	21,350	25,050	14,400	18,000	10,700	—	—	15,400	9250
3200 mm	kg	—	—	18 200*	9800	11 600	6600	8300	4900	—	—	6400*	3800
10'6"	lb	—	—	39,400*	21,100	24,900	14,200	17,850	10,500	—	—	14,050*	8400

North America

335F L ● Reach Boom ● 850 mm (33") Track Shoes ● Heavy Lift Mode On ● No Bucket

Stick		3 m 9'10"		4.5 m 15'0"		6 m 20'0"		7.5 m 25'0"		9 m 30'0"		At Max. Reach	
		Front	Side	Front	Side	Front	Side	Front	Side	Front	Side	Front	Side
3200 mm	kg	6050*	6050*	17 300*	11 050*	12 700*	7350	9200	5400	—	—	6500*	4250
10'6"	lb	13,900*	13,900*	37,500*	23,750*	27,500*	15,800	19,800	11,650	—	—	14,300*	9400

Europe

335F L ● Reach Boom ● 600 mm (24") Track Shoes ● Heavy Lift Mode On ● No Bucket

Stick		3 m 9'10"		4.5 m 15'0"		6 m 20'0"		7.5 m 25'0"		9 m 30'0"		At Max. Reach	
		Front	Side	Front	Side	Front	Side	Front	Side	Front	Side	Front	Side
2650 mm	kg	—	—	17 300*	10 750	12 450	7150	8950	5300	—	—	7550	4500
8'8"	lb	—	—	37,550*	23,050	26,800	15,350	19,250	11,400	—	—	16,600	9900

Asia Pacific

336D2 ● Reach Boom ● 600 mm (24") Track Shoes

Stick	Bucket		3 m 9'10"		4.5 m 15'0"		6 m 20'0"		7.5 m 25'0"		9 m 30'0"		At Max. Reach	
			Front	Side	Front	Side	Front	Side	Front	Side	Front	Side	Front	Side
3200 mm	1.5 m ³	kg	6800*	6800*	16 850	11 000	10 500	7100	7350	5000	5450	3700	4400	2900
10'6"	1.97 yd ³	lb	—	—	—	—	—	—	—	—	—	—	—	—

China

336D2 GC ● Reach Boom ● 600 mm (24") Track Shoes ● 5.2 mt Counterweight

Stick		3 m 9'10"		4.5 m 15'0"		6 m 20'0"		7.5 m 25'0"		9 m 30'0"		At Max. Reach	
		Front	Side	Front	Side	Front	Side	Front	Side	Front	Side	Front	Side
2800 mm	kg	—	—	16 550	11 000	10 500	7300	7600	5400	—	—	6000	4250
9'2"	lb	—	—	35,550	23,700	22,650	15,750	16,400	11,600	—	—	13,150	9350

*Load limited by hydraulic capacity rather than tipping.

Asia Pacific

336D2 L ● Reach Boom ● 600 mm (24") Track Shoes

Stick	Bucket	3 m 9'10"		4.5 m 15'0"		6 m 20'0"		7.5 m 25'0"		9 m 30'0"		At Max. Reach		
		Front	Side	Front	Side	Front	Side	Front	Side	Front	Side	Front	Side	
3200 mm 10'6"	1.5 m ³ 1.97 yd ³	kg	6800*	6800*	17 500*	11 300	12 450*	7300	8900	5200	6650	3850	4700*	3050
		lb	—	—	—	—	—	—	—	—	—	—	—	—

336D2 L ● Mass Boom ● 600 mm (24") Track Shoes

Stick	Bucket	3 m 9'10"		4.5 m 15'0"		6 m 20'0"		7.5 m 25'0"		9 m 30'0"		At Max. Reach		
		Front	Side	Front	Side	Front	Side	Front	Side	Front	Side	Front	Side	
2550 mm 8'4"	1.9 m ³ 2.49 yd ³	kg	—	—	17 150*	10 800	12 250*	6900	8600	4850	—	—	4900*	3200
		lb	—	—	—	—	—	—	—	—	—	—	—	—

*Load limited by hydraulic capacity rather than tipping.

Middle East, Africa

336D2 L ● Reach Boom ● 700 mm (28") Track Shoes

Stick		3 m 9'10"		4.5 m 15'0"		6 m 20'0"		7.5 m 25'0"		9 m 30'0"		At Max. Reach	
		Front	Side	Front	Side	Front	Side	Front	Side	Front	Side	Front	Side
3200 mm 10'6"	kg	—	—	18 900	11 900	13 350	7900	9550	5800	7300	4500	7050	4350
	lb	—	—	40,900	25,550	28,700	16,950	20,500	12,450	15,700	9600	15,500	9500
3900 mm 12'10"	kg	7850	7850	18 550	11 950	13 350	7950	9550	5800	7300	4450	6200	3850
	lb	17,850	17,850	40,100	25,750	28,900	17,100	20,550	12,500	15,700	9600	13,650	8500

336D2 L ● Mass Boom ● 700 mm (28") Track Shoes

Stick		3 m 9'10"		4.5 m 15'0"		6 m 20'0"		7.5 m 25'0"		9 m 30'0"		At Max. Reach	
		Front	Side	Front	Side	Front	Side	Front	Side	Front	Side	Front	Side
2150 mm 7'1"	kg	—	—	18 560*	11 970	13 430*	7860	9530	5730	—	—	8210	4960
	lb	—	—	40,950*	26,400	29,600*	17,350	21,000	12,650	—	—	18,100	10,950
2550 mm 8'4"	kg	—	—	18 560*	12 000	13 440	7860	9500	5690	—	—	7550	4550
	lb	—	—	40,950*	26,450	29,650	17,350	20,950	12,550	—	—	16,650	10,000

*Load limited by hydraulic capacity rather than tipping.
 All weights are without bucket, with quick coupler, heavy lift on.

China, S.E. Asia

336D2 XE ● Reach Boom ● 600 mm (24") Track Shoes ● 5.35 mt Counterweight

Stick		3 m 9'10"		4.5 m 15'0"		6 m 20'0"		7.5 m 25'0"		9 m 30'0"		At Max. Reach	
		Front	Side	Front	Side	Front	Side	Front	Side	Front	Side	Front	Side
2800 mm 9'2"	kg	—	—	17 550	11 700	11 100	7750	8050	5700	—	—	6300	4500
	lb	—	—	37,600	25,150	23,900	16,700	17,300	12,300	—	—	13,850	9900

S.E. Asia, South America, Africa, Middle East, CIS

336D2 L XE ● Mass Boom ● 700 mm (28") Track Shoes ● 5.35 mt Counterweight

Stick		3 m 9'10"		4.5 m 15'0"		6 m 20'0"		7.5 m 25'0"		9 m 30'0"		At Max. Reach	
		Front	Side	Front	Side	Front	Side	Front	Side	Front	Side	Front	Side
2550 mm 8'4"	kg	—	—	18 350*	12 150	13 550*	8050	9700	5900	—	—	8350	5150
	lb	—	—	39,800*	26,100	29,100	17,300	20,800	12,750	—	—	18,400	11,350

*Load limited by hydraulic capacity rather than tipping.

North America

336E L ● Reach Boom ● 800 mm (32") Track Shoes

Stick		3 m 9'10"		4.5 m 15'0"		6 m 20'0"		7.5 m 25'0"		9 m 30'0"		At Max. Reach	
		Front	Side	Front	Side	Front	Side	Front	Side	Front	Side	Front	Side
3200 mm 10'6"	kg lb	—	—	20 550 44,550	13 050 28,050	14 450 31,000	8700 18,700	10 300 22,200	6400 13,800	7950 17,100	5000 10,750	8600 18,950	5350 11,800
3900 mm 12'10"	kg lb	8550*	8550*	20 100*	13 050	14 450	8700	10 300	6400	7900	4950	6750*	4300
		19,400*	19,400*	43,450*	28,050	31,000	18,700	22,150	13,700	16,950	10,600	14,850*	9450

336E L ● Mass Boom ● 800 mm (32") Track Shoes

Stick		3 m 9'10"		4.5 m 15'0"		6 m 20'0"		7.5 m 25'0"		9 m 30'0"		At Max. Reach	
		Front	Side	Front	Side	Front	Side	Front	Side	Front	Side	Front	Side
2550 mm 8'4"	kg lb	—	—	20 450*	12 900	14 300	8550	10 250	6300	—	—	8850	5500
				44,300*	27,800	30,750	18,450	22,000	13,600			19,450	12,150

Europe

336E L ● Reach Boom ● 600 mm (24") Track Shoes

Stick		3 m 9'10"		4.5 m 15'0"		6 m 20'0"		7.5 m 25'0"		9 m 30'0"		At Max. Reach	
		Front	Side	Front	Side	Front	Side	Front	Side	Front	Side	Front	Side
2800 mm 9'2"	kg lb	—	—	20 450*	12 950	14 300	8650	10 250	6400	—	—	8000	5050
				44,750*	27,850	30,750	18,600	22,050	13,750			17,650	11,150
3200 mm 10'6"	kg lb	—	—	20 600*	12 950	14 350	8650	10 300	6400	7900	5000	7650	4800
				44,550*	27,900	30,850	18,650	22,100	13,750	17,000	10,700	16,800	10,600

336E L ● Mass Boom ● 600 mm (24") Track Shoes

Stick		3 m 9'10"		4.5 m 15'0"		6 m 20'0"		7.5 m 25'0"		9 m 30'0"		At Max. Reach	
		Front	Side	Front	Side	Front	Side	Front	Side	Front	Side	Front	Side
2150 mm 7'1"	kg lb	—	—	20 200*	12 800	14 200	8500	10 200	6300	—	—	9500	5900
				43,850*	27,550	30,450	18,300	21,900	13,600			20,900	13,000
2550 mm 8'4"	kg lb	—	—	20 450*	12 800	14 150	8500	10 150	6250	—	—	8750	5450
				44,300*	27,500	30,450	18,300	21,800	13,500			19,300	12,000

336E LN ● Reach Boom ● 600 mm (24") Track Shoes

Stick		3 m 9'10"		4.5 m 15'0"		6 m 20'0"		7.5 m 25'0"		9 m 30'0"		At Max. Reach	
		Front	Side	Front	Side	Front	Side	Front	Side	Front	Side	Front	Side
2800 mm 9'2"	kg lb	—	—	20 450*	11 550	14 050	7750	10 100	5750	—	—	7900	4600
				44,750*	24,850	30,200	16,750	21,700	12,450			17,350	10,100
3200 mm 10'6"	kg lb	—	—	20 550*	11 500	14 050	7750	10 050	5750	7750	4450	7450	4350
				44,550*	24,800	30,200	16,700	21,600	12,350	16,650	9600	16,450	9500

336E LN ● Mass Boom ● 600 mm (24") Track Shoes

Stick		3 m 9'10"		4.5 m 15'0"		6 m 20'0"		7.5 m 25'0"		9 m 30'0"		At Max. Reach	
		Front	Side	Front	Side	Front	Side	Front	Side	Front	Side	Front	Side
2150 mm 7'1"	kg lb	—	—	20 200*	11 400	13 950	7650	10 000	5700	—	—	9350	5350
				43,850*	24,550	29,950	16,450	21,550	12,250			20,550	11,750
2550 mm 8'4"	kg lb	—	—	20 450*	11 400	13 900	7600	9950	5650	—	—	8600	4950
				44,300*	24,500	29,900	16,400	21,450	12,150			18,950	10,850

*Load limited by hydraulic capacity rather than tipping.

North America

336E L H ● Reach Boom ● 850 mm (34") Track Shoes

Stick		3 m 9'10"		4.5 m 15'0"		6 m 20'0"		7.5 m 25'0"		9 m 30'0"		At Max. Reach	
		Front	Side	Front	Side	Front	Side	Front	Side	Front	Side	Front	Side
3200 mm 10'6"	kg lb	—	—	19 850*	12 850	14 300	8550	10 250	6300	7900	4900	7600	4750
				42,950*	27,650	30,750	18,450	22,050	13,600	16,950	10,600	16,750	10,450
3900 mm 12'10"	kg lb	8250*	8250*	19 250*	12 750	13 900*	8500	10 150	6200	7750	4800	6500*	4150
		18,750*	18,750*	41,650*	27,450	30,050*	18,250	21,850	13,400	16,700	10,300	14,300*	9150

Europe

336E L H ● Reach Boom ● 600 mm (24") Track Shoes

Stick		3 m 9'10"		4.5 m 15'0"		6 m 20'0"		7.5 m 25'0"		9 m 30'0"		At Max. Reach	
		Front	Side	Front	Side	Front	Side	Front	Side	Front	Side	Front	Side
2800 mm 9'2"	kg lb	—	—	19 900*	12 850	14 250	8550	10 250	6350	—	—	8000	5000
3200 mm 10'6"	kg lb	—	—	19 850*	12 400	13 800	8250	9900	6100	7600	4750	7350	4600

7

336E LN H ● Reach Boom ● 600 mm (24") Track Shoes

Stick		3 m 9'10"		4.5 m 15'0"		6 m 20'0"		7.5 m 25'0"		9 m 30'0"		At Max. Reach	
		Front	Side	Front	Side	Front	Side	Front	Side	Front	Side	Front	Side
2800 mm 9'2"	kg lb	—	—	19 900*	11 250	13 800	7550	9900	5600	—	—	7750	4450
3200 mm 10'6"	kg lb	—	—	19 850*	11 200	13 750	7500	9850	5550	7550	4350	7300	4200

North America

336F L ● Reach Boom ● 800 mm (32") Track Shoes

Stick		3 m 9'10"		4.5 m 15'0"		6 m 20'0"		7.5 m 25'0"		9 m 30'0"		At Max. Reach	
		Front	Side	Front	Side	Front	Side	Front	Side	Front	Side	Front	Side
3200 mm 10'6"	kg lb	—	—	20 550	13 050	14 450	8700	10 300	6400	7950	5000	8600	5350
				44,550	28,050	31,000	18,700	22,200	13,800	17,100	10,750	18,950	11,800
3900 mm 12'10"	kg lb	8550	8550	20 100	13 050	14 450	8700	10 300	6400	7900	4950	6750	4300
		19,400	19,400	43,450	28,050	31,000	18,700	22,150	13,700	16,950	10,600	14,850	9450

336F L ● Mass Boom ● 800 mm (32") Track Shoes

Stick		3 m 9'10"		4.5 m 15'0"		6 m 20'0"		7.5 m 25'0"		9 m 30'0"		At Max. Reach	
		Front	Side	Front	Side	Front	Side	Front	Side	Front	Side	Front	Side
2550 mm 8'4"	kg lb	—	—	20 450	12 900	14 300	8550	10 250	6300	—	—	8850	5500
				44,300	27,800	30,750	18,450	22,000	13,600			19,450	12,150

*Load limited by hydraulic capacity rather than tipping.

Hydraulic Excavators

Lifting Capacity At Ground Level

- 336F L ● 336F LN ● 336F L XE
- 336F LN XE ● 340D2 L ● 340F L

North America

336F L ● Reach Boom ● 850 mm (34") Track Shoes ● 6.0 mt Counterweight

Stick		3 m 9'10"		4.5 m 15'0"		6 m 20'0"		7.5 m 25'0"		9 m 30'0"		At Max. Reach	
		Front	Side	Front	Side	Front	Side	Front	Side	Front	Side	Front	Side
3900 mm	kg	8250*	8250*	20 100*	13 600	14 500*	9050	10 700	6650	8200	5150	6750*	4500
12'10"	lb	18,800*	18,800*	43,450*	29,200	31,400*	19,450	23,000	14,300	17,600	11,050	14,800*	9850

Europe

336F LN ● Reach Boom ● 600 mm (24") Track Shoes ● 7.0 mt Counterweight

Stick		3 m 9'10"		4.5 m 15'0"		6 m 20'0"		7.5 m 25'0"		9 m 30'0"		At Max. Reach	
		Front	Side	Front	Side	Front	Side	Front	Side	Front	Side	Front	Side
3200 mm	kg	—	—	20 300*	12 900	14 800*	8700	11 100	6450	8550	5050	8250	4900
10'6"	lb	—	—	43,950*	27,750	32,000*	18,700	23,900	13,900	18,400	10,850	18,200	10,700

North America, Europe

336F L XE ● Reach Boom ● 850 mm (34") Track Shoes ● 5.05 mt Counterweight

Stick		3 m 9'10"		4.5 m 15'0"		6 m 20'0"		7.5 m 25'0"		9 m 30'0"		At Max. Reach	
		Front	Side	Front	Side	Front	Side	Front	Side	Front	Side	Front	Side
3900 mm	kg	8250*	8250*	19 450*	13 200	14 050*	8800	10 450	6450	8000	5000	6550*	4350
12'10"	lb	18,800*	18,800*	42,050*	28,400	30,400*	18,900	22,450	13,900	17,200	10,750	14,400*	9550

Europe

336F LN XE ● Reach Boom ● 600 mm (24") Track Shoes ● 6.05 mt Counterweight

Stick		3 m 9'10"		4.5 m 15'0"		6 m 20'0"		7.5 m 25'0"		9 m 30'0"		At Max. Reach	
		Front	Side	Front	Side	Front	Side	Front	Side	Front	Side	Front	Side
3200 mm	kg	—	—	19 600*	12 600	14 300*	8500	10 950	6300	8400	4950	8150	4750
10'6"	lb	—	—	42,500*	27,150	30,950*	18,350	23,550	13,600	18,100	10,600	17,900	10,500

China, S.E. Asia, South America except Brazil, Africa, Middle East, CIS

340D2 L ● Mass Boom ● 600 mm (24") Track Shoes ● 6.26 mt Counterweight

Stick		3 m 9'10"		4.5 m 15'0"		6 m 20'0"		7.5 m 25'0"		9 m 30'0"		At Max. Reach	
		Front	Side	Front	Side	Front	Side	Front	Side	Front	Side	Front	Side
2550 mm	kg	—	—	18 350*	15 600	13 550*	10 150	10 550	7450	—	—	9100	6500
8'4"	lb	—	—	39,800*	33,500	29,300*	21,850	22,700	16,050	—	—	20,050	14,250

Europe

340F L ● Reach Boom ● 600 mm (24") Track Shoes ● 7.0 mt Counterweight

Stick		3 m 9'10"		4.5 m 15'0"		6 m 20'0"		7.5 m 25'0"		9 m 30'0"		At Max. Reach	
		Front	Side	Front	Side	Front	Side	Front	Side	Front	Side	Front	Side
3200 mm	kg	—	—	20 350*	17 350	14 900*	11 400	11 600	8350	8950	6550	8750	6350
10'6"	lb	—	—	44,100*	37,300	32,250*	24,500	25,000	18,000	19,300	14,050	19,250	14,000

*Load limited by hydraulic capacity rather than tipping.

Asia Pacific, CIS

349D2 ● Reach Boom ● 600 mm (24") Track Shoes ● 9.0 mt Counterweight

Stick		4.5 m 15'0"		6 m 20'0"		7.5 m 25'0"		9 m 30'0"		10.5 m 35'0"		At Max. Reach	
		Front	Side	Front	Side	Front	Side	Front	Side	Front	Side	Front	Side
2900 mm	kg	18 500*	18 500	17 300*	12 100	13 300	8950	10 250	7000	—	—	9700	6600
9'6"	lb	43,150*	43,150	37,400*	26,050	28,650	19,250	22,100	15,050	—	—	21,400	14,550
3350 mm	kg	19 900*	18 350	17 250*	12 150	13 350	8950	10 250	6950	—	—	9100	6200
11'0"	lb	46,150*	39,450	37,300*	26,150	28,700	19,300	22,100	15,000	—	—	20,050	13,650
3900 mm	kg	22 550*	18 350	17 000*	12 150	13 300*	8950	10 250	6950	—	—	8550	5800
12'10"	lb	50,750*	39,450	36,750*	26,150	28,700	19,250	22,050	14,950	—	—	18,800	12,750

349D2 ● Mass Boom ● 600 mm (24") Track Shoes ● 9.0 mt Counterweight

Stick		4.5 m 15'0"		6 m 20'0"		7.5 m 25'0"		9 m 30'0"		10.5 m 35'0"		At Max. Reach	
		Front	Side	Front	Side	Front	Side	Front	Side	Front	Side	Front	Side
2500 mm	kg	22 650*	18 200	17 050*	11 950	13 200	8800	—	—	—	—	10 800	7300
8'2"	lb	49,200*	39,050	36,950*	25,700	28,350	18,900	—	—	—	—	23,750	16,000
3000 mm	kg	23 000*	18 050	16 950*	11 850	13 100	8700	10 050	6750	—	—	9900	6650
9'10"	lb	49,900*	38,750	36,650*	25,550	28,150	18,700	—	—	—	—	21,800	14,650

7

South America, Asia Pacific, Middle East, Africa, CIS, New Zealand, Australia

349D2 L ● Reach Boom ● 600 mm (24") Track Shoes ● 9.0 mt Counterweight

Stick		4.5 m 15'0"		6 m 20'0"		7.5 m 25'0"		9 m 30'0"		10.5 m 35'0"		At Max. Reach	
		Front	Side	Front	Side	Front	Side	Front	Side	Front	Side	Front	Side
2900 mm	kg	18 400*	18 400*	17 300*	12 150	13 550*	9000	11 100*	7000	—	—	10 500*	6650
9'6"	lb	43,000*	39,650	37,400*	26,200	29,400*	19,350	23,950*	15,150	—	—	23,150*	14,650
3350 mm	kg	19 850*	18 450	17 250*	12 200	13 500*	9000	11 100*	7000	—	—	9550*	6250
11'0"	lb	46,050*	39,700	37,300*	26,300	29,250*	19,400	24,000*	15,100	—	—	21,050*	13,750
3900 mm	kg	22 500*	18 450	16 950*	12 250	13 300*	9000	10 950*	7000	—	—	8700*	5850
12'10"	lb	50,750*	39,700	36,750*	26,350	28,750*	19,400	23,750*	15,050	—	—	19,100*	12,850

349D2 L ● Mass Boom ● 600 mm (24") Track Shoes ● 9.0 mt Counterweight

Stick		4.5 m 15'0"		6 m 20'0"		7.5 m 25'0"		9 m 30'0"		10.5 m 35'0"		At Max. Reach	
		Front	Side	Front	Side	Front	Side	Front	Side	Front	Side	Front	Side
2500 mm	kg	22 650*	18 300	17 050*	12 000	13 400*	8850	—	—	—	—	11 300*	7300
8'2"	lb	49,250*	39,300	36,950*	25,850	29,000*	19,050	—	—	—	—	24,900*	16,100
3000 mm	kg	23 000*	18 150	16 950*	11 950	13 250*	8750	10 750*	6800	—	—	10 600*	6700
9'10"	lb	49,900*	39,000	36,650*	25,700	28,700*	18,850	—	—	—	—	23,350*	14,750

*Load limited by hydraulic capacity rather than tipping.

Australia, New Zealand

349E L – FIX ● Reach Boom ● 900 mm (35") Track Shoes ● Heavy Lift

Stick		3 m 9'10"		4.5 m 15'0"		6 m 20'0"		7.5 m 25'0"		9 m 30'0"		At Max. Reach	
		Front	Side	Front	Side	Front	Side	Front	Side	Front	Side	Front	Side
3350 mm	kg	—	—	21 000*	19 850	21 450*	13 150	15 800	9700	12 100	7550	10 450*	6750
11'0"	lb	—	—	48,750*	42,700	46,450*	28,300	34,000	20,900	26,050	16,300	23,050*	14,800
3900 mm	kg	—	—	23 850*	19 850	21 100*	13 150	15 800	9650	12 100	7550	9500*	6300
12'10"	lb	—	—	55,200*	42,650	45,650*	28,300	33,950	20,850	26,000	16,200	20,950*	13,900

349E L – FIX ● Mass Boom ● 900 mm (35") Track Shoes ● Heavy Lift

Stick		3 m 9'10"		4.5 m 15'0"		6 m 20'0"		7.5 m 25'0"		9 m 30'0"		At Max. Reach	
		Front	Side	Front	Side	Front	Side	Front	Side	Front	Side	Front	Side
2500 mm	kg	—	—	23 950*	19 450	21 150*	12 750	15 500	9350	—	—	12 600	7750
8'2"	lb	—	—	56,350*	41,800	45,800*	27,450	33,350	20,200	—	—	27,800	17,050
3000 mm	kg	—	—	25 950*	19 250	20 900*	12 650	15 400	9250	11 750	7200	11 550	7050
9'10"	lb	—	—	60,500*	41,350	45,300*	27,200	33,100	19,950	25,904	15,873	25,450	15,550

349E L – VG ● Reach Boom ● 900 mm (35") Track Shoes ● Heavy Lift

Stick		3 m 9'10"		4.5 m 15'0"		6 m 20'0"		7.5 m 25'0"		9 m 30'0"		At Max. Reach	
		Front	Side	Front	Side	Front	Side	Front	Side	Front	Side	Front	Side
3350 mm	kg	—	—	21 550*	21 550*	21 500*	14 650	16 450	10 750	12 600	8400	10 600*	7550
11'0"	lb	—	—	49,900*	48,000	46,500*	31,550	35,350	23,200	27,150	18,100	23,350*	16,600
3900 mm	kg	9700*	9700*	24 100*	22 300	21 150*	14 650	16 400	10 750	12 600	8350	9600*	7050
12'10"	lb	22,000*	22,000*	55,700*	47,900	45,850*	31,500	35,350	23,150	27,100	18,050	21,200*	15,550

North America

349F L – FIX ● Long Reach Boom ● 900 mm (35") Track Shoes ● Heavy Lift Mode On

Stick		4.5 m 15'0"		6 m 20'0"		7.5 m 25'0"		9 m 30'0"		10.5 m 35'0"		At Max. Reach	
		Front	Side	Front	Side	Front	Side	Front	Side	Front	Side	Front	Side
4300 mm	kg	18 100*	18 100*	20 050*	12 550	15 550	9250	11 850	7150	9450	5700	8750*	5300
14'1"	lb	41,800*	40,750	43,400*	27,050	33,450	19,900	25,500	15,400	20,350	12,300	19,250*	11,700

349F L – FIX ● Reach Boom ● 900 mm (35") Track Shoes ● Heavy Lift Mode On

Stick		4.5 m 15'0"		6 m 20'0"		7.5 m 25'0"		9 m 30'0"		10.5 m 35'0"		At Max. Reach	
		Front	Side	Front	Side	Front	Side	Front	Side	Front	Side	Front	Side
3350 mm	kg	20 950*	19 850	21 150*	13 150	16 000	9700	12 250	7550	—	—	10 400*	6700
11'0"	lb	48,650*	42,700	45,800*	28,300	34,400	20,850	26,350	16,250	—	—	22,900*	14,800
3900 mm	kg	23 800*	19 700	20 700*	13 050	15 900	9600	12 150	7450	—	—	9400*	6250
12'10"	lb	55,050*	42,450	44,850*	28,150	34,250	20,700	26,150	16,050	—	—	20,700*	13,700

349F XE ● Reach Boom ● 900 mm (35") Track Shoes ● 9.0 mt Counterweight ● Heavy Lift Mode On

Stick		4.5 m 15'0"		6 m 20'0"		7.5 m 25'0"		9 m 30'0"		10.5 m 35'0"		At Max. Reach	
		Front	Side	Front	Side	Front	Side	Front	Side	Front	Side	Front	Side
3350 mm	kg	20 950*	20 200	21 150*	13 350	16 200	9850	12 450	7700	—	—	10 400*	6850
11'0"	lb	48,650*	43,400	45,800*	28,750	34,900	21,200	26,750	16,550	—	—	22,900*	15,050
3900 mm	kg	23 800*	20 050	20 700*	13 250	16 150	9750	12 350	7600	—	—	9400*	6350
12'10"	lb	55,050*	43,150	44,850*	28,600	34,750	21,050	26,550	16,350	—	—	20,700*	13,950

*Load limited by hydraulic capacity rather than tipping.

North America

**352F ● Reach Boom ● 600 mm (24") Track Shoes
● 9.0 mt Counterweight ● Heavy Lift Mode On**

Stick		4.5 m 15'0"		6 m 20'0"		7.5 m 25'0"		9 m 30'0"		10.5 m 35'0"		At Max. Reach	
		Front	Side	Front	Side	Front	Side	Front	Side	Front	Side	Front	Side
2900 mm	kg	21 650*	21 650*	21 350*	14 400	16 350	10 600	12 550	8300	—	—	12 100	8000
9'6"	lb	50,250*	47,300	46,200*	31,050	35,200	22,850	27,050	17,900	—	—	26,650	17,600
3350 mm	kg	21 550*	21 550*	21 150*	14 350	16 300	10 550	12 500	8250	—	—	10 500*	7350
11'0"	lb	49,900*	47,100	45,850*	30,900	35,050	22,750	26,900	17,750	—	—	23,150*	16,250

**352F ● Mass Boom ● 600 mm (24") Track Shoes
● 9.0 mt Counterweight ● Heavy Lift Mode On**

Stick		4.5 m 15'0"		6 m 20'0"		7.5 m 25'0"		9 m 30'0"		10.5 m 35'0"		At Max. Reach	
		Front	Side	Front	Side	Front	Side	Front	Side	Front	Side	Front	Side
2500 mm	kg	25 200*	21 750	20 950*	14 150	16 150	10 400	—	—	—	—	13 300	8650
8'2"	lb	59,000*	46,750	45,400*	30,500	34,800	22,400	—	—	—	—	29,250	19,050
3000 mm	kg	26 700*	21 550	20 800*	14 050	16 050	10 300	12 300	8000	—	—	12 150	7900
9'10"	lb	61,250*	46,350	45,050*	30,250	34,550	22,150	—	—	—	—	26,800	17,450

352F – VG ● Long Reach Boom ● 900 mm (35") Track Shoes ● Heavy Lift Mode On

Stick		3 m 9'10"		4.5 m 15'0"		6 m 20'0"		At Max. Reach	
		Front	Side	Front	Side	Front	Side	Front	Side
4300 mm	kg	7500*	7500*	18 350*	18 350*	20 150*	13 900	8850*	5950
14'1"	lb	17,000*	17,000*	42,250*	42,250*	43,550*	29,950	19,450*	13,050

Stick		7.5 m 25'0"		9 m 30'0"		10.5 m 35'0"		At Max. Reach	
		Front	Side	Front	Side	Front	Side	Front	Side
4300 mm	kg	15 700*	10 200	12 300	7900	9850	6350	8850*	5950
14'1"	lb	33,950*	22,000	26,500	17,050	21,150	13,650	19,450*	13,050

352F – VG ● Reach Boom ● 900 mm (35") Track Shoes ● Heavy Lift Mode On

Stick		3 m 9'10"		4.5 m 15'0"		6 m 20'0"		At Max. Reach	
		Front	Side	Front	Side	Front	Side	Front	Side
3350 mm	kg	—	—	21 500*	21 500*	21 200*	14 500	10 550*	7450
11'0"	lb	—	—	49,850*	47,600	45,900*	31,250	23,200*	16,400
3900 mm	kg	9650*	9650*	24 050*	22 000	20 800*	14 450	9550*	6950
12'10"	lb	21,850*	21,850*	55,600*	47,250	45,000*	31,050	21,000*	15,250

Stick		7.5 m 25'0"		9 m 30'0"		10.5 m 35'0"		At Max. Reach	
		Front	Side	Front	Side	Front	Side	Front	Side
3350 mm	kg	16 550	10 700	12 700	8350	—	—	10 550*	7450
11'0"	lb	35,650	23,000	27,350	17,950	—	—	23,200*	16,400
3900 mm	kg	16 300*	10 600	12 600	8200	—	—	9550*	6950
12'10"	lb	35,250*	22,800	27,150	17,700	—	—	21,000*	15,250

*Load limited by hydraulic capacity rather than tipping.

Europe

352F XE ● Reach Boom ● 600 mm (24") Track Shoes
● 9.0 mt Counterweight ● Heavy Lift Mode On

Stick		4.5 m 15'0"		6 m 20'0"		7.5 m 25'0"		9 m 30'0"		10.5 m 35'0"		At Max. Reach	
		Front	Side	Front	Side	Front	Side	Front	Side	Front	Side	Front	Side
2900 mm	kg	21 650*	21 650*	21 350*	14 650	16 600	10 800	12 750	8450			12 250	8150
9'6"	lb	50,250*	48,050	46,200*	31,550	35,700	23,250	27,450	18,200	—	—	27,000	17,900
3350 mm	kg	21 550*	21 550*	21 150*	14 600	16 500	10 750	12 700	8350			10 500*	7500
11'0"	lb	49,900*	47,850	45,850*	31,400	35,550	23,100	27,300	18,000	—	—	23,150*	16,500

352F XE ● Mass Boom ● 600 mm (24") Track Shoes
● 9.0 mt Counterweight ● Heavy Lift Mode On

Stick		4.5 m 15'0"		6 m 20'0"		7.5 m 25'0"		9 m 30'0"		10.5 m 35'0"		At Max. Reach	
		Front	Side	Front	Side	Front	Side	Front	Side	Front	Side	Front	Side
2500 mm	kg	25 200*	22 100	20 950*	14 400	16 400	10 550					13 450	8800
8'2"	lb	59,000*	47,500	45,400*	31,000	35,300	22,750	—	—	—	—	29,650	19,400
3000 mm	kg	26 700*	21 900	20 800*	14 300	16 300	10 450	12 450	8150			12 350	8050
9'10"	lb	61,250*	47,050	45,050*	30,750	35,050	22,500	—	—	—	—	27,200	17,750

North America

374D L ● 7.8 m (25'7") Reach Boom ● 900 mm (35") Double Grousers

Stick		4.5 m 15'0"		6 m 20'0"		7.5 m 25'0"		9 m 30'0"		10.5 m 35'0"		At Max. Reach	
		Front	Side	Front	Side	Front	Side	Front	Side	Front	Side	Front	Side
2840 mm	kg	—	—	26 500*	23 100	21 150*	16 800	17 350*	13 100			14 800*	11 100
9'4"	lb	—	—	57,500*	49,700	45,850*	36,150	37,600*	28,250	—	—	32,600*	24,400
3600 mm	kg	—	—	26 850*	23 100	21 150*	16 800	17 350*	13 050	14 550*	10 550	13 900*	10 100
11'10"	lb	34,650*	34,650*	58,200*	49,750	45,750*	36,200	37,550*	28,100	31,350*	22,750	30,600*	22,200
4150 mm	kg	16 850*	16 850*	26 850*	23 200	21 000*	16 850	17 250*	13 050	14 550*	10 550	13 050	9400
13'7"	lb	39,000*	39,000*	58,100*	49,950	45,450*	36,300	37,300*	28,150	31,450	22,650	28,700	20,700
4670 mm	kg	17 300*	17 300*	26 500*	23 200	20 650*	16 800	16 950*	13 000	14 350*	10 450	11 700*	8700
15'4"	lb	39,900*	39,900*	57,300*	49,900	57,300*	36,200	36,700*	28,000	31,100*	22,450	25,800*	19,150

374D L ● 7.0 m (23'0") Mass Boom ● 900 mm (35") Double Grousers

Stick		4.5 m 15'0"		6 m 20'0"		7.5 m 25'0"		9 m 30'0"		10.5 m 35'0"		At Max. Reach	
		Front	Side	Front	Side	Front	Side	Front	Side	Front	Side	Front	Side
2570 mm	kg	26 950*	26 950*	26 650*	23 200	21 050*	16 800	17 100*	13 100			16 750*	12 950
8'5"	lb	63,150*	63,150*	57,750*	49,900	45,550*	36,200	—	—	—	—	36,950*	28,550
3000 mm	kg	29 000*	29 000*	26 700*	23 150	20 950*	16 750	17 100*	12 950			15 950*	12 100
9'10"	lb	67,300*	67,300*	57,800*	49,800	45,400*	36,050	36,900*	27,950	—	—	35,150*	26,600

*Load limited by hydraulic capacity rather than tipping.

Europe, Middle East, Africa, CIS, Asia Pacific

374D L ● 7.8 m (25'7") Reach Boom ● 750 mm (30") Double Grousers

Stick		4.5 m 15'0"		6 m 20'0"		7.5 m 25'0"		9 m 30'0"		10.5 m 35'0"		At Max. Reach	
		Front	Side	Front	Side	Front	Side	Front	Side	Front	Side	Front	Side
2840 mm 9'4"	kg lb	—	—	26 500* 57,500*	22 750 48,950	21 150* 45,850*	16 550 35,600	17 350* 37,600*	12 900 27,800	—	—	14 800* 32,600*	10 900 24,050
3600 mm 11'10"	kg lb	—	—	26 850* 58,200*	22 800 49,000	21 150* 45,750*	16 550 35,650	17 350* 37,550*	12 850 27,650	14 400 31,050	10 400 22,400	13 750 30,300	9550 21,850
4150 mm 13'7"	kg lb	16 850* 39,000*	16 850* 39,000*	26 850* 58,100*	22 850 49,200	21 000* 45,450*	16 600 35,750	17 250* 37,300*	12 850 27,700	14 400 30,950	10 350 22,300	12 800 28,250	9250 20,400
4670 mm 15'4"	kg lb	17 300* —	17 300* —	26 500* —	22 850 —	20 650* —	16 550 —	16 950* —	12 800 —	14 300 —	10 250 —	11 700* —	8550 —

374D L ● 7.0 m (23'0") Mass Boom ● 750 mm (30") Double Grousers

Stick		4.5 m 15'0"		6 m 20'0"		7.5 m 25'0"		9 m 30'0"		10.5 m 35'0"		At Max. Reach	
		Front	Side	Front	Side	Front	Side	Front	Side	Front	Side	Front	Side
2570 mm 8'5"	kg lb	26 950* 63,150*	26 950* 63,150*	26 650* 57,750*	22 850 49,150	21 050* 45,550*	16 550 35,650	17 000* —	12 900 —	—	—	16 750* 36,950*	12 750 28,100
3000 mm 9'10"	kg lb	29 000* 67,300*	29 000* 67,300*	26 700* 57,800*	22 800 49,050	20 950* 45,400*	16 500 35,500	17 100* 36,900*	12 750 27,500	—	—	15 950* 35,150*	11 900 26,200

7

Asia Pacific

374D L ● 7.8 m (25'7") Reach Boom ● 650 mm (26") Double Grousers

Stick		4.5 m 15'0"		6 m 20'0"		7.5 m 25'0"		9 m 30'0"		10.5 m 35'0"		At Max. Reach	
		Front	Side	Front	Side	Front	Side	Front	Side	Front	Side	Front	Side
2840 mm 9'4"	kg lb	—	—	26 500* 57,500*	22 550 48,500	21 150* 45,850*	16 350 35,250	17 350* 37,600*	12 750 27,500	—	—	14 800* 32,600*	10 800 23,800
3600 mm 11'10"	kg lb	—	—	26 850* 58,200*	22 550 48,550	21 150* 45,750*	16 350 35,300	17 350* 37,550*	12 700 27,400	14 250 30,700	10 300 22,150	13 600 29,950	9800 21,650
4150 mm 13'7"	kg lb	16 850* 39,000*	16 850* 39,000*	26 850* 58,100*	22 650 48,750	21 000* 45,450*	16 450 35,400	17 250* 37,300*	12 750 27,400	14 250 30,650	10 250 22,050	12 700 27,950	9150 20,150

North America

374F L ● 7.8 m (25'7") Reach Boom ● 900 mm (35") Double Grousers

Stick		4.5 m 15'0"		6 m 20'0"		7.5 m 25'0"		9 m 30'0"		10.5 m 35'0"		At Max. Reach	
		Front	Side	Front	Side	Front	Side	Front	Side	Front	Side	Front	Side
2840 mm 9'4"	kg lb	—	—	28 450* 61,800*	23 000 49,450	22 750* 49,300*	16 700 35,950	18 150 39,100	13 000 28,050	—	—	15 250 33,550	11 000 24,250
3600 mm 11'10"	kg lb	—	—	28 850* 62,550*	23 000 49,500	22 750* 49,200*	16 700 35,950	18 100 39,000	12 950 27,950	14 550 31,300	10 500 22,600	13 850 30,550	10 000 22,050
4150 mm 13'7"	kg lb	17 900* 41,350*	17 900* 41,350*	28 800* 62,300*	23 000 49,550	22 550* 48,800*	16 700 36,000	18 100 38,950	12 950 27,900	14 500 31,200	10 450 22,450	12 900 28,450	9350 20,550
4670 mm 15'4"	kg lb	18 350* 42,350*	18 350* 42,350*	28 450* 61,550*	23 050 49,550	22 200* 48,000*	16 700 35,950	18 050 38,850	12 900 27,800	14 400 31,000	10 350 22,300	12 000 26,350	8600 19,000

374F L ● 7.0 m (23'0") Mass Boom ● 900 mm (35") Double Grousers

Stick		4.5 m 15'0"		6 m 20'0"		7.5 m 25'0"		9 m 30'0"		10.5 m 35'0"		At Max. Reach	
		Front	Side	Front	Side	Front	Side	Front	Side	Front	Side	Front	Side
2570 mm 8'5"	kg lb	28 500* 66,800*	28 500* 66,800*	28 650* 62,150*	23 150 49,800	22 650* 49,050*	16 750 36,100	18 250 —	13 050 —	—	—	18 050 39,700	12 900 28,450
3000 mm 9'10"	kg lb	30 800* 71,400*	30 800* 71,400*	28 650* 62,100*	23 000 49,550	22 550* 48,850*	16 650 35,850	18 100 38,950	12 900 27,800	—	—	16 800 37,050	12 050 26,500

*Load limited by hydraulic capacity rather than tipping.

Europe, Middle East, Africa, CIS, Asia Pacific

374F L ● 7.8 m (25'7") Reach Boom ● 750 mm (30") Double Grousers

Stick		4.5 m 15'0"		6 m 20'0"		7.5 m 25'0"		9 m 30'0"		10.5 m 35'0"		At Max. Reach	
		Front	Side	Front	Side	Front	Side	Front	Side	Front	Side	Front	Side
2840 mm	kg	—	—	28 450*	22 650	22 750*	16 450	17 900	12 800	—	—	15 000	10 850
9'4"	lb	—	—	61,800*	48,700	49,300*	35,400	38,550	27,650	—	—	33,050	23,900
3600 mm	kg	—	—	28 850*	22 650	22 750*	16 450	17 850	12 750	14 300	10 350	13 650	9850
11'10"	lb	36,750*	36,750*	62,550*	48,750	49,200*	35,450	38,400	27,500	30,850	22,250	30,100	21,750
4150 mm	kg	17 900*	17 900*	28 800*	22 700	22 550*	16 450	17 850	12 750	14 250	10 300	12 700	9200
13'7"	lb	41,350*	41,350*	62,300*	48,850	48,800*	35,450	38,400	27,500	30,700	22,150	28,000	20,200
4670 mm	kg	18 350*	18 350*	28 450*	22 700	22 200*	16 450	17 800	12 700	14 200	10 200	11 800	8500
15'4"	lb	42,350*	42,350*	61,550*	48,850	48,000*	35,400	38,300	27,350	30,550	21,950	25,950	18,700

374F L ● 7.0 m (23'0") Mass Boom ● 750 mm (30") Double Grousers

Stick		4.5 m 15'0"		6 m 20'0"		7.5 m 25'0"		9 m 30'0"		10.5 m 35'0"		At Max. Reach	
		Front	Side	Front	Side	Front	Side	Front	Side	Front	Side	Front	Side
2570 mm	kg	28 500*	28 500*	28 650*	22 800	22 650*	16 500	18 000	12 850	—	—	17 750	12 700
8'5"	lb	66,800*	66,800*	62,150*	49,050	49,050*	35,600	—	—	—	—	39,150	28,000
3000 mm	kg	30 800*	30 800*	28 650*	22 700	22 550	16 400	17 850	12 700	—	—	16 550	11 850
9'10"	lb	71,400*	71,400*	62,100*	48,800	48,850	35,350	38,400	27,400	—	—	36,450	26,100

Asia Pacific

374F L ● 7.8 m (25'7") Reach Boom ● 650 mm (26") Double Grousers

Stick		4.5 m 15'0"		6 m 20'0"		7.5 m 25'0"		9 m 30'0"		10.5 m 35'0"		At Max. Reach	
		Front	Side	Front	Side	Front	Side	Front	Side	Front	Side	Front	Side
2840 mm	kg	—	—	28 450*	22 400	22 750*	16 250	17 700	12 700	—	—	14 850	10 750
9'4"	lb	—	—	61,800*	48,250	49,300*	35,050	38,150	27,350	—	—	32,700	23,650
3600 mm	kg	—	—	28 850*	22 450	22 750*	16 300	17 650	12 650	14 150	10 200	13 500	9750
11'10"	lb	36,750*	36,750*	62,550*	48,300	49,200*	35,100	38,000	27,250	30,500	22,000	29,750	21,500
4150 mm	kg	17 900*	17 900*	28 800*	22 450	22 550*	16 300	17 650	12 650	14 100	10 150	12 600	9100
13'7"	lb	41,350*	41,350*	62,300*	48,350	48,800*	35,100	38,000	27,200	30,400	21,900	27,700	20,000

*Load limited by hydraulic capacity rather than tipping.

North America, South America

390D L ● 8.4 m (27'7") GP Boom ● 900 mm (35") Track Shoes

Stick		4.5 m 15'0"		6 m 20'0"		7.5 m 25'0"		9 m 30'0"	
		Front	Side	Front	Side	Front	Side	Front	Side
3400 mm	kg	—	—	33 250*	29 300	28 650*	21 100	23 500*	16 350
11'2"	lb	—	—	77,850*	63,000	62,050*	45,450	50,850*	35,200
4400 mm	kg	—	—	36 650*	29 500	28 750*	21 350	23 500*	16 550
14'5"	lb	—	—	79,450*	63,500	62,250*	46,000	50,950*	35,650
5500 mm	kg	19 000*	19 000*	36 450*	30 100	28 300*	21 800	23 150*	16 850
18'1"	lb	43,500*	43,500*	78,950*	64,750	61,300*	46,900	50,150*	36,250

Stick		10.5 m 35'0"		12 m 40'0"		13.5 m 45'0"		At Max. Reach	
		Front	Side	Front	Side	Front	Side	Front	Side
3400 mm	kg	19 650*	13 200	—	—	—	—	17 150*	11 800
11'2"	lb	42,500*	28,400	—	—	—	—	37,750*	26,050
4400 mm	kg	19 850*	13 300	16 550	11 050	—	—	13 300*	10 750
14'5"	lb	43,000*	28,700	29,800*	23,750	—	—	29,250*	23,700
5500 mm	kg	19 650*	13 500	16 650	11 100	—	—	9750*	9600
18'1"	lb	42,550*	29,050	35,800	23,900	—	—	21,450*	21,100

390D L ● 10 m (32'10") Reach Boom ● 900 mm (35") Track Shoes

Stick		4.5 m 15'0"		6 m 20'0"		7.5 m 25'0"		9 m 30'0"	
		Front	Side	Front	Side	Front	Side	Front	Side
4400 mm	kg	—	—	13 200*	13 200*	26 650*	19 100	21 850*	14 900
14'5"	lb	—	—	31,400*	31,400*	57,700*	41,200	47,300*	32,100
5500 mm	kg	—	—	17 000*	17 000*	26 700*	19 500	21 700*	15 200
18'1"	lb	—	—	39,600*	39,600*	57,800*	42,050	47,000*	32,700

Stick		10.5 m 35'0"		12 m 40'0"		13.5 m 45'0"		At Max. Reach	
		Front	Side	Front	Side	Front	Side	Front	Side
4400 mm	kg	18 400*	12 050	15 500	10 000	13 100	8400	12 750	8200
14'5"	lb	39,850*	25,950	33,350	21,500	28,150	18,100	28,050	18,000
5500 mm	kg	18 250*	12 250	15 650	10 100	13 150	8500	11 350*	7350
18'1"	lb	39,550*	26,400	33,650	21,750	28,300	18,250	25,000*	16,200

390D L ● 7.25 m (23'9") Mass Boom ● 900 mm (35") Track Shoes

Stick		4.5 m 15'0"		6 m 20'0"		7.5 m 25'0"		9 m 30'0"	
		Front	Side	Front	Side	Front	Side	Front	Side
2920 mm	kg	25 950*	25 950*	36 300*	30 250	28 850*	21 800	23 300*	16 850
9'7"	lb	60,500*	60,500*	78,850*	65,100	62,500*	46,950	50,250*	36,350
3400 mm	kg	27 950*	27 950*	37 150*	30 500	29 300*	22 000	23 800*	17 000
11'2"	lb	64,650*	64,650*	80,500*	65,650	63,500*	47,350	51,450*	36,550

Stick		10.5 m 35'0"		12 m 40'0"		13.5 m 45'0"		At Max. Reach	
		Front	Side	Front	Side	Front	Side	Front	Side
2920 mm	kg	—	—	—	—	—	—	20 950*	15 350
9'7"	lb	—	—	—	—	—	—	46,200*	33,800
3400 mm	kg	—	—	—	—	—	—	19 550*	14 500
11'2"	lb	—	—	—	—	—	—	43,100*	31,900

*Load limited by hydraulic capacity rather than tipping.

Middle East, Africa, CIS

390D L ● 8.4 m (27'7") GP Boom ● 650 mm (26") Track Shoes

Stick		4.5 m 15'0"		6 m 20'0"		7.5 m 25'0"		9 m 30'0"	
		Front	Side	Front	Side	Front	Side	Front	Side
3400 mm 11'2"	kg lb	—	—	33 250* 77,850*	28 600 61,500	28 650* 62,050*	20 600 44,350	23 500* 50,850*	15 950 34,350
4400 mm 14'5"	kg lb	—	—	36 650* 79,450*	28 800 62,000	28 750* 62,250*	20 850 44,900	23 500* 50,950*	16 150 34,800
5500 mm 18'1"	kg lb	19 000* 43,500*	19 000* 43,500*	36 450* 78,950*	29 400 63,300	28 300* 61,300*	21 300 45,850	23 150* 50,150*	16 450 35,400
Stick		10.5 m 35'0"		12 m 40'0"		13.5 m 45'0"		At Max. Reach	
		Front	Side	Front	Side	Front	Side	Front	Side
3400 mm 11'2"	kg lb	19 450 41,900	12 850 27,700	—	—	—	—	17 150* 37,750*	11 500 25,400
4400 mm 14'5"	kg lb	19 600 42,200	13 000 28,000	16 150 29,800*	10 750 23,150	—	—	13 300* 29,250*	10 500 23,100
5500 mm 18'1"	kg lb	19 650* 42,550*	13 150 28,350	16 250 34,950	10 850 23,300	—	—	9750* 21,450*	9350 20,550

390D L ● 10 m (32'10") Reach Boom ● 650 mm (26") Track Shoes

Stick		4.5 m 15'0"		6 m 20'0"		7.5 m 25'0"		9 m 30'0"	
		Front	Side	Front	Side	Front	Side	Front	Side
4400 mm 14'5"	kg lb	—	—	13 200* 31,400*	13 200* 31,400*	26 650* 57,700*	18 600 40,100	21 850* 47,300*	14 500 31,200
5500 mm 18'1"	kg lb	—	—	17 000* 39,600*	17 000* 39,600*	26 700* 57,800*	19 000* 40,950*	21 700* 47,000*	14 800 31,850
Stick		10.5 m 35'0"		12 m 40'0"		13.5 m 45'0"		At Max. Reach	
		Front	Side	Front	Side	Front	Side	Front	Side
4400 mm 14'5"	kg lb	18 300 39,400	11 700 25,250	15 100 32,500	9700 20,850	12 750 27,400	8150 17,550	12 400 27,300	7950 17,500
5500 mm 18'1"	kg lb	18 250* 39,550*	11 950 25,700	15 250 32,800	9850 21,150	12 800 27,550	8250 17,700	11 200 24,600	7150 15,750

390D L ● 8.4 m (27'7") GP Boom ● 750 mm (30") Track Shoes

Stick		4.5 m 15'0"		6 m 20'0"		7.5 m 25'0"		9 m 30'0"	
		Front	Side	Front	Side	Front	Side	Front	Side
3400 mm 11'2"	kg lb	—	—	33 250* 77,850*	28 900 62,200	28 650* 62,050*	20 800 44,850	23 500* 50,850*	16 100 34,700
4400 mm 14'5"	kg lb	—	—	36 650* 79,450*	29 100 62,650	28 750* 62,250*	21 050 45,400*	23 500* 50,950*	16 300 35,150
5500 mm 18'1"	kg lb	19 000* 43,500*	19 000* 43,500*	36 450* 78,950*	29 700 63,950	28 300* 61,300*	21 500 46,300	23 150* 50,150*	16 600 35,750
Stick		10.5 m 35'0"		12 m 40'0"		13.5 m 45'0"		At Max. Reach	
		Front	Side	Front	Side	Front	Side	Front	Side
3400 mm 11'2"	kg lb	19 650 42,350	13 000 28,000	—	—	—	—	17 150* 37,750*	11 650 25,650
4400 mm 14'5"	kg lb	19 800 42,650*	13 150 28,300	16 300 29,800*	10 850 23,400	—	—	13 300* 29,250*	10 600 23,350
5500 mm 18'1"	kg lb	19 650* 42,550*	13 300 28,650	16 400 35,300	10 950 23,550	—	—	9750* 21,450*	9450 20,800

*Load limited by hydraulic capacity rather than tipping.

Middle East, Africa, CIS

390D L ● 10 m (32'10") Reach Boom ● 750 mm (30") Track Shoes

Stick		4.5 m 15'0"		6 m 20'0"		7.5 m 25'0"		9 m 30'0"	
		Front	Side	Front	Side	Front	Side	Front	Side
4400 mm	kg	—	—	13 200*	13 200*	26 650*	18 850	21 850*	14 650
14'5"	lb	—	—	31,400*	31,400*	57,700*	40,600	47,300*	31, 600
5500 mm	kg	—	—	17 000*	17 000*	26 700*	19 200*	21 700*	14 950
18'1"	lb	—	—	39,600*	39,600*	57,800*	41,450*	47,000*	32,250

Stick		10.5 m 35'0"		12 m 40'0"		13.5 m 45'0"		At Max. Reach	
		Front	Side	Front	Side	Front	Side	Front	Side
4400 mm	kg	18 400*	11 850	15 250	9800	12 900	8300	12 550	8050
14'5"	lb	39,850	25,550	32,850	21,150	27,750	17,800	27,600	17,700
5500 mm	kg	18 250*	12 050	15 400	9950	12 950	8350	11 300	7250
18'1"	lb	39,550*	26,000	33,200	21,400	27,850	17,950	24,900	15,950

390D L ● 7.25 m (23'9") Mass Boom ● 650 mm (26") Track Shoes

Stick		4.5 m 15'0"		6 m 20'0"		7.5 m 25'0"		9 m 30'0"	
		Front	Side	Front	Side	Front	Side	Front	Side
2920 mm	kg	25 950*	25 950*	36 300*	29 550	28 850*	21 300	23 300*	16 450
9'7"	lb	60,500*	60,500*	78,850*	63,600	62,500*	45,850	50,250*	35,500
3400 mm	kg	27 950*	27 950*	37 150*	29 800	29 300*	21 450	23 800*	16 600
11'2"	lb	64,650*	64,650*	80,500*	64,150	63,500*	46,250	51,450*	35,700

Stick		10.5 m 35'0"		12 m 40'0"		13.5 m 45'0"		At Max. Reach	
		Front	Side	Front	Side	Front	Side	Front	Side
2920 mm	kg	—	—	—	—	—	—	20 950*	15 000
9'7"	lb	—	—	—	—	—	—	46,200*	33,000
3400 mm	kg	—	—	—	—	—	—	19 550*	14 150
11'2"	lb	—	—	—	—	—	—	43,100*	31,150

390D L ● 7.25 m (23'9") Mass Boom ● 750 mm (30") Track Shoes

Stick		4.5 m 15'0"		6 m 20'0"		7.5 m 25'0"		9 m 30'0"	
		Front	Side	Front	Side	Front	Side	Front	Side
2920 mm	kg	25 950*	25 950*	36 300*	29 850	28 850*	21 500	23 300*	16 650
9'7"	lb	60,500*	60,500*	78,850*	64,250	62,500*	46,300	50,250*	35,850
3400 mm	kg	27 950*	27 950*	37 150*	29 800	29 300*	21 450	23 800*	16 600
11'2"	lb	64,650*	64,650*	80,500*	64,800	63,500*	46,700	51,450*	36,100

Stick		10.5 m 35'0"		12 m 40'0"		13.5 m 45'0"		At Max. Reach	
		Front	Side	Front	Side	Front	Side	Front	Side
2920 mm	kg	—	—	—	—	—	—	20 950*	15 150
9'7"	lb	—	—	—	—	—	—	46,200*	33,350
3400 mm	kg	—	—	—	—	—	—	19 550*	14 150
11'2"	lb	—	—	—	—	—	—	43,100*	31,450

*Load limited by hydraulic capacity rather than tipping.

Asia Pacific

390D L ● 8.4 m (27'7") GP Boom ● 650 mm (26") Track Shoes

		4.5 m 15'0"		6 m 20'0"		7.5 m 25'0"		9 m 30'0"	
Stick		Front	Side	Front	Side	Front	Side	Front	Side
3400 mm 11'2"	kg lb	—	—	33 250*	28 600	28 650*	20 600	23 500*	15 950
4400 mm 14'5"	kg lb	—	—	36 650*	28 800	28 750*	20 850	23 500*	16 150
5500 mm 18'1"	kg lb	19 000*	19 000*	36 450*	29 400	28 300*	21 300	23 150*	16 450
		—	—	—	—	—	—	—	—
		10.5 m 35'0"		12 m 40'0"		13.5 m 45'0"		At Max. Reach	
Stick		Front	Side	Front	Side	Front	Side	Front	Side
3400 mm 11'2"	kg lb	19 450	12 850	—	—	—	—	17 150*	11 500
		—	—					37,750*	25,400
4400 mm 14'5"	kg lb	19 600	13 000	16 150	10 750	—	—	13 300*	10 500
		—	—	—	—			29,250*	23,100
5500 mm 18'1"	kg lb	19 650*	13 150	16 250	10 850	—	—	9750*	9350
		—	—	—	—			21,450*	20,550

390D L ● 10 m (32'10") Reach Boom ● 650 mm (26") Track Shoes

		4.5 m 15'0"		6 m 20'0"		7.5 m 25'0"		9 m 30'0"	
Stick		Front	Side	Front	Side	Front	Side	Front	Side
4400 mm 14'5"	kg lb	—	—	13 200*	13 200*	26 650*	18 600	21 850*	14 500
5500 mm 18'1"	kg lb	—	—	17 000*	17 000*	25 300	18 550	19 400	14 450
		—	—	—	—	—	—	—	—
		10.5 m 35'0"		12 m 40'0"		13.5 m 45'0"		At Max. Reach	
Stick		Front	Side	Front	Side	Front	Side	Front	Side
4400 mm 14'5"	kg lb	18 300	11 700	15 100	9700	12 750	8150	12 400	7950
		—	—	—	—	—	—	—	—
5500 mm 18'1"	kg lb	15 550	11 650	12 850	9600	10 750	8050	9400	6950
		—	—	—	—	—	—	—	—

*Load limited by hydraulic capacity rather than tipping.

North America, South America

390F L ● 8.4 m (27'7") GP Boom ● 900 mm (35") Track Shoes

Stick		4.5 m 15'0"		6 m 20'0"		7.5 m 25'0"		9 m 30'0"	
		Front	Side	Front	Side	Front	Side	Front	Side
3400 mm	kg	—	—	33 250*	28 550	28 200*	20 500	23 100*	15 850
11'2"	lb	—	—	76,750*	61,350	61,150*	44,150	50,050*	34,150
4400 mm	kg	—	—	36 500*	29 050	28 650*	21 050	23 450*	16 300
14'5"	lb	—	—	79,150*	62,550	62,000*	45,300	50,750*	35,100
5500 mm	kg	18 900*	18 900*	35 800*	29 150	27 750*	21 050	22 700*	16 250
18'1"	lb	43,300*	43,300*	77,500*	62,750	60,100*	45,400	49,100*	34,950

Stick		10.5 m 35'0"		12 m 40'0"		13.5 m 45'0"		At Max. Reach	
		Front	Side	Front	Side	Front	Side	Front	Side
3400 mm	kg	19 350*	12 800	—	—	—	—	17 050	11 450
11'2"	lb	41,700	27,500	—	—	—	—	37,500	25,200
4400 mm	kg	19 700	13 100	16 250	10 850	—	—	13 300*	10 600
14'5"	lb	42,400	28,250	29,700*	23,350	—	—	29,250*	23,300
5500 mm	kg	19 200*	13 000	16 050	10 650	—	—	9600*	9150
18'1"	lb	41,600*	27,950	34,550	22,900	—	—	21,100*	20,200

390F L ● 10 m (32'10") Reach Boom ● 900 mm (35") Track Shoes

Stick		4.5 m 15'0"		6 m 20'0"		7.5 m 25'0"		9 m 30'0"	
		Front	Side	Front	Side	Front	Side	Front	Side
4400 mm	kg	—	—	13 250*	13 250*	26 400*	18 700	21 650*	14 550
14'5"	lb	—	—	31,500*	31,500*	57,150*	40,250	46,850*	31,350
5500 mm	kg	—	—	16 950*	16 950*	25 950*	18 600	21 100*	14 450
18'1"	lb	—	—	39,400*	39,400*	56,200*	40,150	45,650*	31,150

Stick		10.5 m 35'0"		12 m 40'0"		13.5 m 45'0"		At Max. Reach	
		Front	Side	Front	Side	Front	Side	Front	Side
4400 mm	kg	18 250*	11 750	15 100	9750	12 750	8200	12 400	8000
14'5"	lb	39,450*	25,350	32,550	20,950	27,450	17,650	27,350	17,550
5500 mm	kg	17 700*	11 650	15 000	9600	12 550	8000	10 950	6900
18'1"	lb	38,300*	25,050	32,200	20,600	27,000	17,150	24,100	15,200

390F L ● 7.25 m (23'9") Mass Boom ● 900 mm (35") Track Shoes

Stick		4.5 m 15'0"		6 m 20'0"		7.5 m 25'0"		9 m 30'0"	
		Front	Side	Front	Side	Front	Side	Front	Side
2920 mm	kg	26 100*	26 100*	36 200*	29 850	28 800*	21 500	23 250*	16 650
9'7"	lb	60,800*	60,800*	78,600*	64,200	62,300*	46,300	50,100*	35,850
3400 mm	kg	27 900*	27 900*	36 650*	29 750	28 900*	21 400	23 450*	16 500
11'2"	lb	64,500*	64,500*	79,450*	64,000	62,550*	46,050	50,650*	35,500

Stick		10.5 m 35'0"		12 m 40'0"		13.5 m 45'0"		At Max. Reach	
		Front	Side	Front	Side	Front	Side	Front	Side
2920 mm	kg	—	—	—	—	—	—	20 900*	15 150
9'7"	lb	—	—	—	—	—	—	46,100*	33,400
3400 mm	kg	—	—	—	—	—	—	19 400*	14 050
11'2"	lb	—	—	—	—	—	—	42,800*	30,950

*Load limited by hydraulic capacity rather than tipping.

Middle East, Africa, CIS

390F L ● 8.4 m (27'7") GP Boom ● 650 mm (26") Track Shoes

Stick		4.5 m 15'0"		6 m 20'0"		7.5 m 25'0"		9 m 30'0"	
		Front	Side	Front	Side	Front	Side	Front	Side
3400 mm 11'2"	kg lb	—	—	33 250* 76,750*	27 850 59,900	28 200* 61,150*	20 000 43,100	23 100* 50,050*	15 450 33,300
4400 mm 14'5"	kg lb	—	—	36 500* 79,150*	28 400 61,100	28 650* 62,000*	20 550 44,250	23 450* 50,750*	15 900 34,250
5500 mm 18'1"	kg lb	18 900* 43,300*	18 900* 43,300*	35 800* 77,500*	28 500 61,300	27 750* 60,100*	20 600 44,350	22 700* 49,100*	15 850 34,150
Stick		10.5 m 35'0"		12 m 40'0"		13.5 m 45'0"		At Max. Reach	
		Front	Side	Front	Side	Front	Side	Front	Side
3400 mm 11'2"	kg lb	18 900 40,700	12 450 26,850	—	—	—	—	16 850 37,150	11 150 24,550
4400 mm 14'5"	kg lb	19 250 41,400	12 800 27,550	15 850 29,700*	10 600 22,750	—	—	13 300* 29,250*	10 350 22,750
5500 mm 18'1"	kg lb	19 150 41,200	12 700 27,300	15 650 33,700	10 400 22,350	—	—	9600* 21,100*	8950 19,650

390F L ● 10 m (32'10") Reach Boom ● 650 mm (26") Track Shoes

Stick		4.5 m 15'0"		6 m 20'0"		7.5 m 25'0"		9 m 30'0"	
		Front	Side	Front	Side	Front	Side	Front	Side
4400 mm 14'5"	kg lb	—	—	13 250* 31,500*	13 250* 31,500*	26 400* 57,150*	18 200 39,200	21 650* 46,850*	14 150 30,500
5500 mm 18'1"	kg lb	—	—	16 950* 39,400*	16 950* 39,400*	25 950* 56,200*	18 150 39,100	21 100* 45,650*	14 100 30,350
Stick		10.5 m 35'0"		12 m 40'0"		13.5 m 45'0"		At Max. Reach	
		Front	Side	Front	Side	Front	Side	Front	Side
4400 mm 14'5"	kg lb	17 850 38,450	11 450 24,650	14 750 31,700	9450 20,400	12 400 26,750	7950 17,150	12 100 26,600	7750 17,050
5500 mm 18'1"	kg lb	17 700* 38,250	11 350 24,350	14 600 31,350	9300 20,000	12 200 26,250	7750 16,650	10 650 23,450	6700 14,750

390F L ● 8.4 m (27'7") GP Boom ● 750 mm (30") Track Shoes

Stick		4.5 m 15'0"		6 m 20'0"		7.5 m 25'0"		9 m 30'0"	
		Front	Side	Front	Side	Front	Side	Front	Side
3400 mm 11'2"	kg lb	—	—	33 250* 76,750*	28 150 60,550	28 200* 61,150*	20 250 43,600	23 100* 50,050*	15 650 33,700
4400 mm 14'5"	kg lb	—	—	36 500* 79,150*	28 700 61,750	28 650* 62,000*	20 750 44,750	23 450* 50,750*	16 100 34,650
5500 mm 18'1"	kg lb	18 900* 43,300*	18 900* 43,300*	35 800* 77,500*	28 800 62,000	27 750* 60,100*	20 800 44,800	22 700* 49,100*	16 050 34,500
Stick		10.5 m 35'0"		12 m 40'0"		13.5 m 45'0"		At Max. Reach	
		Front	Side	Front	Side	Front	Side	Front	Side
3400 mm 11'2"	kg lb	19 100 41,150	12 600 27,150	—	—	—	—	17 050* 37,500*	11 300 24,850
4400 mm 14'5"	kg lb	19 450 41,850	12 950 27,850	16 000 29,700*	10 700 23,050	—	—	13 300* 29,250*	10 450 23,000
5500 mm 18'1"	kg lb	19 200* 41,600*	12 800 27,600	15 850 34,100	10 500 22,600	—	—	9600* 21,100*	9050 19,900

*Load limited by hydraulic capacity rather than tipping.

Middle East, Africa, CIS

390F L ● 10 m (32'10") Reach Boom ● 750 mm (30") Track Shoes

Stick		4.5 m 15'0"		6 m 20'0"		7.5 m 25'0"		9 m 30'0"	
		Front	Side	Front	Side	Front	Side	Front	Side
4400 mm	kg	—	—	13 250*	13 250*	26 400*	18 400	21 650*	14 350
14'5"	lb	—	—	31,500*	31,500*	57,150*	39,700	46,850*	30,900
5500 mm	kg	—	—	16 950*	16 950*	25 950*	18 350	21 100*	14 250
18'1"	lb	—	—	39,400*	39,400*	56,200*	39,550	45,650*	30,700

Stick		10.5 m 35'0"		12 m 40'0"		13.5 m 45'0"		At Max. Reach	
		Front	Side	Front	Side	Front	Side	Front	Side
4400 mm	kg	18 100	11 600	14 900	9600	12 550	8100	12 250	7850
14'5"	lb	38,950	24,950	32,100	20,650	27,050	17,350	26,950	17,300
5500 mm	kg	17 700*	11 450	14 750	9450	12 350	7850	10 800	6800
18'1"	lb	38,300*	24,700	31,750	20,250	26,600	16,900	23,750	14,950

390F L ● 7.25 m (23'9") Mass Boom ● 650 mm (26") Track Shoes

Stick		4.5 m 15'0"		6 m 20'0"		7.5 m 25'0"		9 m 30'0"	
		Front	Side	Front	Side	Front	Side	Front	Side
2920 mm	kg	26 100*	26 100*	36 200*	29 200	28 800*	21 000	23 250*	16 250
9'7"	lb	60,800*	60,800*	78,600*	62,800	62,300*	45,250	50,100*	35,050
3400 mm	kg	27 900*	27 900*	36 650*	29 100	28 900*	20 900	23 450	16 100
11'2"	lb	64,500*	64,500*	79,450*	62,550	62,550*	45,000	50,650	34,650

Stick		10.5 m 35'0"		12 m 40'0"		13.5 m 45'0"		At Max. Reach	
		Front	Side	Front	Side	Front	Side	Front	Side
2920 mm	kg	—	—	—	—	—	—	20 900*	14 800
9'7"	lb	—	—	—	—	—	—	46,100*	32,600
3400 mm	kg	—	—	—	—	—	—	19 400*	13 700
11'2"	lb	—	—	—	—	—	—	42,800*	30,200

390F L ● 7.25 m (23'9") Mass Boom ● 750 mm (30") Track Shoes

Stick		4.5 m 15'0"		6 m 20'0"		7.5 m 25'0"		9 m 30'0"	
		Front	Side	Front	Side	Front	Side	Front	Side
2920 mm	kg	26 100*	26 100*	36 200*	29 500	28 800*	21 250	23 250*	16 450
9'7"	lb	60,800*	60,800*	78,600*	63,450	62,300*	45,700	50,100*	35,400
3400 mm	kg	27 900*	27 900*	36 650*	29 400	28 900*	21 100	23 450*	16 250
11'2"	lb	64,500*	64,500*	79,450*	63,200	62,550*	45,450	50,650*	35,050

Stick		10.5 m 35'0"		12 m 40'0"		13.5 m 45'0"		At Max. Reach	
		Front	Side	Front	Side	Front	Side	Front	Side
2920 mm	kg	—	—	—	—	—	—	20 900*	14 950
9'7"	lb	—	—	—	—	—	—	46,100*	32,950
3400 mm	kg	—	—	—	—	—	—	19 400*	13 850
11'2"	lb	—	—	—	—	—	—	42,800*	30,550

*Load limited by hydraulic capacity rather than tipping.

Asia Pacific

390F L ● 8.4 m (27'7") GP Boom ● 650 mm (26") Track Shoes

Stick		4.5 m 15'0"		6 m 20'0"		7.5 m 25'0"		9 m 30'0"	
		Front	Side	Front	Side	Front	Side	Front	Side
3400 mm 11'2"	kg lb	—	—	33 250* 76,750*	27 850 59,900	28 200* 61,150*	20 000 43,100	23 100* 50,050*	15 450 33,300
4400 mm 14'5"	kg lb	—	—	36 500* 79,150*	28 400 61,100	28 650* 62,000*	20 550 44,250	23 450* 50,750*	15 900 34,250
5500 mm 18'1"	kg lb	18 900* 43,300*	18 900* 43,300*	35 800* 77,500*	28 500 61,300	27 750* 60,100*	20 600 44,350	22 700* 49,100*	15 850 34,150
Stick		10.5 m 35'0"		12 m 40'0"		13.5 m 45'0"		At Max. Reach	
		Front	Side	Front	Side	Front	Side	Front	Side
3400 mm 11'2"	kg lb	18 900 40,700	12 450 26,850	—	—	—	—	16 850 37,150	11 150 24,550
4400 mm 14'5"	kg lb	19 250 41,400	12 800 27,550	15 850 29,700*	10 600 22,750	—	—	13 300* 29,250*	10 350 22,750
5500 mm 18'1"	kg lb	19 150 41,200	12 700 27,300	15 650 33,700	10 400 22,350	—	—	9600* 21,100*	8950 19,650

390F L ● 10 m (32'10") Reach Boom ● 650 mm (26") Track Shoes

Stick		4.5 m 15'0"		6 m 20'0"		7.5 m 25'0"		9 m 30'0"	
		Front	Side	Front	Side	Front	Side	Front	Side
4400 mm 14'5"	kg lb	—	—	13 250* 31,500*	13 250* 31,500*	26 400* 57,150*	18 200 39,200	21 650* 46,850*	14 150 30,500
5500 mm 18'1"	kg lb	—	—	16 950* 39,400*	16 950 39,400	25 950* 56,200*	18 150 39,100	21 100* 45,650*	14 100 30,350
Stick		10.5 m 35'0"		12 m 40'0"		13.5 m 45'0"		At Max. Reach	
		Front	Side	Front	Side	Front	Side	Front	Side
4400 mm 14'5"	kg lb	17 850 38,450	11 450 24,650	14 750 31,700	9450 20,400	12 400 26,750	7950 17,150	12 100 26,600	7750 17,050
5500 mm 18'1"	kg lb	17 700* 38,250	11 350 24,350	14 600 31,350	9300 20,000	12 200 26,250	7750 16,650	10 650 23,450	6700 14,750

*Load limited by hydraulic capacity rather than tipping.

Model	Bucket Family	Interface	Bucket Type	Width Range		Capacity Range		Weight Range		GET
				mm	in	m ³	yd ³	kg	lb	
311F 312E 314E	312	Pin-On/ Pin Grabber	General Duty	450-1200	18-48	0.20-0.76	0.27-1.00	266-487	585-1074	J250
			General Duty Wide Tip	450-1200	18-48	0.27-1.00	0.35-1.33	317-579	699-1276	J250
			Severe Duty	600-1050	24-42	0.31-0.65	0.40-0.84	351-502	774-1106	J300
			Cleanup	1500	60	1.02	1.33	630	1389	BOCE
			Ditch Cleaning	1200-1500	48-60	0.57-0.73	0.75-0.95	389-456	858-1005	BOCE
			Ditch Cleaning Tilt	1500	60	0.57	0.75	514	1133	None
		Dedicated	General Duty	600-1050	24-42	0.30-0.64	0.39-0.83	314-445	693-982	J250
			Heavy Duty Rock	600-1050	24-42	0.30-0.63	0.39-0.82	377-515	831-1134	J300
			Ditch Cleaning	1500	60	0.74	0.97	465	1025	BOCE
Pin-Lock	Heavy Duty	600-900	24-36	0.38-0.61	0.50-0.80	338-433	745-955	J250		
	Ditch Cleaning	1500	60	0.69	0.90	429	945	BOCE		
316E 316F M313D M315D M316D M318F	315	Pin-On/ Pin Grabber	General Duty	600-1200	24-48	0.35-0.91	0.46-1.19	429-625	945-1378	K80
			General Duty Wide Tip	600-1200	24-48	0.42-1.17	0.55-1.53	449-700	990-1543	K80
			Severe Duty	600-1200	24-48	0.35-0.91	0.46-1.19	480-730	1058-1609	K90
			Cleanup	1500	60	1.24	1.62	770	1698	BOCE
			Ditch Cleaning	1500-1820	60-72	0.93-1.14	1.23-1.50	582-663	1283-1462	BOCE
			Ditch Cleaning Tilt	1500	60	0.70	0.87	809	1783	BOCE
		Center-Lock™ Pin Grabber Performance	General Duty	600-900	24-36	0.33-0.57	0.43-0.75	413-539	910-1188	K80
			Severe Duty	1050-1200	24-48	0.70-0.83	0.92-1.09	664-731	1464-1612	K90
		Dedicated	General Duty	600-1050	24-42	0.42-0.92	0.55-1.20	406-570	896-1257	K80
			Severe Duty	600-1050	24-42	0.42-0.88	0.55-1.15	515-713	1135-1573	K90
			Ditch Cleaning	1820	72	1.14	1.49	662	1459	BOCE
		Pin-Lock	Heavy Duty	600-1200	24-48	0.38-0.92	0.50-1.20	540-834	1190-1839	J300
Ditch Cleaning	1200-1800		48-72	0.61-0.99	0.80-1.30	481-650	1060-1434	BOCE		
318E 318F	315	Pin-On/ Pin Grabber	General Duty	900-1200	36-48	0.62-0.91	0.81-1.91	538-661	1186-1457	K80
			Heavy Duty	600-1200	24-48	0.35-0.91	0.46-1.19	449-679	990-1497	K80
			Severe Duty	900-1050	36-42	0.62-0.76	0.81-1.00	625-683	1378-1506	K80
			Cleanup	1500	60	1.24	1.62	770	1698	BOCE
			Ditch Cleaning	1500	60	0.93	1.22	582	1283	BOCE
			Ditch Cleaning Tilt	1500	60	0.70	0.87	809	1783	BOCE
		Center-Lock Pin Grabber Performance	General Duty	600-900	24-36	0.33-0.57	0.43-0.75	413-539	910-1188	K80
			Severe Duty	1050-1200	24-48	0.70-0.83	0.92-1.09	664-731	1464-1612	K90
319D M318D M320F	B	Pin-On/ Pin Grabber	General Duty	600-1400	24-55	0.39-1.18	0.50-1.54	458-730	1010-1609	K80
			Heavy Duty	900-1200	36-48	0.68-0.98	0.88-1.29	605-707	1335-1559	K80

7

Model	Bucket Family	Interface	Bucket Type	Width Range		Capacity Range		Weight Range		GET
				mm	in	m ³	yd ³	kg	lb	
321D CR 323F M322D	B	Pin-On/ Pin Grabber	General Duty	600-1350	24-54	0.55-1.59	0.72-2.08	601-963	1324-2124	K80
			General Duty Wide Tip	600-1350	24-54	0.55-1.59	0.72-2.08	615-1016	1356-2239	K80
			Heavy Duty	600-1350	24-54	0.46-1.38	0.61-1.81	629-1006	1387-2217	K90
			Heavy Duty Power	900-1200	36-48	0.79-1.14	1.03-1.49	808-952	1781-2099	K90
			Severe Duty	600-1200	24-48	0.46-1.19	0.61-1.56	674-1012	1485-2231	K90
			Severe Duty Power	900	36	0.79	1.03	874	1926	K90
			Cleanup	1800	72	1.60	2.09	979	2158	BOCE
			Ditch Cleaning	1500-1800	60-72	1.02-1.24	1.33-1.63	652-740	1437-1631	BOCE
			Ditch Cleaning Tilt	1500-1800	60-72	0.86-0.96	1.12-1.25	1032-1104	2275-2433	BOCE
		Center-Lock Pin Grabber Performance	Heavy Duty	600-1350	24-54	0.44-1.28	0.57-1.67	656-1056	1446-2328	K90
		Dedicated	General Duty	1200	48	1.38	1.80	956	2107	K80
Heavy Duty	675-1350	27-54	0.54-1.37	0.71-1.80	701-1036	1545-2285	K90			
Ditch Cleaning	1500	60	1.01	1.32	686	1512	BOCE			
323F LR 326F LR 329F LR	A	Pin-On/ Pin Grabber	General Purpose	900	36	0.53	0.69	403	888	J250
			Ditch Cleaning	1200	48	0.57	0.75	386	851	None/ BOCE
326F 329F 335F	CB	Pin-On/ Pin Grabber	General Duty	600-1350	24-54	0.63-1.83	0.83-2.40	704-1118	1552-2464	K90
			General Duty Wide Tip	600-1350	24-54	0.63-1.83	0.83-2.40	729-1176	1607-2592	K90
			Heavy Duty	600-1650	24-66	0.52-1.97	0.68-2.58	734-1290	1619-2844	K100
			Heavy Duty Power	1050-1350	42-54	1.12-1.53	1.47-2.01	1006-1176	2218-2592	K100
			Severe Duty	600-1200	24-48	0.52-1.33	0.68-1.74	781-1130	1721-2491	K100
			Cleanup	1800	72	1.81	2.37	1196	2527	BOCE
			Ditch Cleaning	1500-1800	60-72	1.25-1.53	1.63-2.00	793-897	1627-1973	BOCE
			Ditch Cleaning Tilt	1800	72	1.14	1.50	1531	3374	BOCE
			Center-Lock Pin Grabber Performance	Heavy Duty	750-1500	30-60	0.70-1.69	0.91-2.21	839-1311	1849-2890
		Severe Duty	600-1200	24-48	0.51-1.28	0.66-1.68	794-1207	1750-2661	K100	
		Dedicated	General Purpose	1350	54	1.83	2.40	1156	2549	K90
Heavy Duty	900-1350	36-54	0.93-1.57	1.22-2.05	924-1161	2037-2560	K100			
Ditch Cleaning	1800	72	1.53	2.00	897	1978	BOCE			
326F 329F 336E 336F	DB	Pin-On/ Pin Grabber	General Duty	750-1650	30-66	0.94-2.55	1.23-3.33	924-1470	2037-3240	K100
			General Duty Wide Tip	800-1550	32-62	1.18-2.27	1.54-2.98	1042-1463	2298-3225	K100
			Heavy Duty	750-1800	30-72	0.73-2.36	0.95-3.08	995-1767	2194-3896	K110
			Heavy Duty Power	900-1500	36-60	0.95-1.86	1.24-2.43	1123-1561	2476-3441	K110
			Severe Duty	750-1350	30-54	0.73-1.64	0.95-2.14	1060-1539	2336-3393	K110
			Extreme Duty	1200	48	1.40	1.84	1596	3519	K110
			Cleanup	1800	72	2.48	3.24	1444	3184	BOCE
			Ditch Cleaning	1500-1800	60-72	1.63-1.91	2.13-2.50	1088-1216	2394-2677	BOCE
			Center-Lock Pin Grabber Performance	Heavy Duty	900-1650	36-66	0.87-1.93	1.14-2.52	1158-1728	2553-3809
		Severe Duty	750-1350	30-54	0.68-1.50	0.88-1.97	1063-1588	2344-3501	K110	
		Dedicated	General Purpose	1500	60	2.27	2.98	1394	3073	K100
Heavy Duty	750-1500	30-60	0.74-1.87	0.96-2.45	965-1538	2128-3391	K110			
Cleanup	1800-2100	72-83	2.48-2.91	3.24-3.81	1416-1567	3122-3455	BOCE			
Ditch Cleaning	1800	72	1.91	2.50	1175	2590	BOCE			

Model	Bucket Family	Interface	Bucket Type	Width Range		Capacity Range		Weight Range		GET
				mm	in	m ³	yd ³	kg	lb	
336E 336F 349E 349F	TB	Pin-On/ Pin Grabber	General Duty	750-1850	30-74	0.95-3.08	1.24-4.04	1275-2170	2811-4784	K110
			General Duty High Capacity	2000	80	3.82	5.00	2373	5232	K110
			General Duty Wide Tip	900-1950	36-78	1.35-3.41	1.77-4.46	1457-2420	3212-5335	K110
			Heavy Duty	900-1800	36-72	1.08-2.69	1.41-3.52	1546-2339	3409-5156	K110
			Severe Duty	750-1850	30-74	0.88-2.69	1.15-3.52	1410-2612	3109-5759	K130
			Extreme Duty	1250-1400	49-55	1.60-1.87	2.09-2.44	2148-2290	4735-5048	K130
		Center-Lock Pin Grabber Performance	Heavy Duty	1200-1850	48-74	1.49-2.56	1.95-3.34	1870-2501	4122-5514	K110
349E 349F	UB	Pin-On/ Pin Grabber	Heavy Duty	1650-1950	65-77	2.77-3.43	3.62-4.48	2486-2803	5481-6180	K130
			Severe Duty	1450-1850	58-73	2.39-3.21	3.13-4.20	2464-2892	5432-6375	K130
374D 374F	VB2	Pin-On/ Pin Grabber	General Duty	1900	75	3.80	5.00	3565	7859	K150
			General Duty High Capacity	2000	79	4.60	6.00	3922	8646	K150
			Heavy Duty	1220-1900	48-75	2.20-3.80	2.90-5.00	2799-3726	6170-8214	K150
			Severe Duty	1100-1900	43-75	1.90-3.80	2.50-5.00	2747-3861	6056-8512	K150
			Extreme Duty	1900	75	3.80	5.00	4682	10,322	K150
374D 374F	WB2	Pin-On/ Pin Grabber	Severe Duty	1900-2000	75-79	4.00-4.40	5.25-5.75	4661-4818	10,276-10,622	K170
			Extreme Duty	2000-2100	79-83	4.40-4.60	5.70-6.00	5787-6060	12,758-13,360	K170
390D 390F	HB2	Pin-On/ Pin Grabber	General Duty	1350-1900	54-75	3.00-4.60	4.00-6.00	3282-4000	7236-8818	K150
			General Duty High Capacity	2000	79	5.30	7.00	4245	9359	K150
			Severe Duty	1100-1910	43-75	2.30-4.60	3.00-6.00	3189-4398	7030-9696	K150
390D 390F	JC	Pin-On/ Pin Grabber	General Duty	2300-2420	91-95	5.70-6.00	7.40-7.90	5576-5758	12,293-12,694	K170
			General Duty High Capacity	2575	101	6.50	8.50	5992	13,210	K170
			Severe Duty	1960-2440	77-96	4.60-6.00	6.00-7.90	5858-6878	12,915-15,163	J800
			Extreme Duty	2090	82	5.00	6.50	7353-7455	16,221-16,435	J800

Model	Bucket Family	Interface	Bucket Type	Width Range		Capacity Range		Weight Range		GET	
				mm	in	m ³	yd ³	kg	lb		
312D2	312	Pin-On/ Pin Grabber	General Duty Severe Duty	1200	48	0.76	1.00	487	1074	J250	
				900-1050	36-42	0.53-0.65	0.69-0.84	456-502	1005-1106	J300	
318D2 M315D2 M316D M317D2	315	Pin-On/ Pin Grabber	General Duty Severe Duty	1200	48	0.91	1.19	625	1378	K80	
				1200	48	0.91	1.19	730	1609	K90	
320D2 321D CR M322D	B	Pin-On/ Pin Grabber	Heavy Duty	1050-1350	42-54	1.00-1.40	1.31-1.83	846-978	1866-2156	K90	
323D2	B	Pin-On/ Pin Grabber	Heavy Duty	1200-1350	48-54	1.19-1.40	1.56-1.83	891-978	1965-2156	K90	
323D2	CB	Pin-On	Severe Duty Power	1350	54	1.56	2.04	1256	2770	K100	
			Dedicated	Severe Duty	1350	54	1.56	2.04	1208	2664	K100
326D2 328D CR 329D2	CB	Pin-On/ Pin Grabber	Heavy Duty	1500	60	1.76	2.30	1181	2605	K100	
326D2 329D2	DB	Pin-On	Severe Duty	1350-1650	54-66	1.66-2.15	2.17-2.81	1528-1767	3368-3896	K100	
			Dedicated	Severe Duty	1500-1650	60-66	1.90-2.15	2.50-2.81	1613-1741	3556-3838	K110
336D2	DB	Pin-On/ Pin Grabber	Heavy Duty	1650	66	2.12	2.77	1613	3556	K110	
			Severe Duty	1350-1650	54-66	1.66-2.15	2.17-2.81	1528-1767	3368-3896	K110	
336D2	TB	Pin-On	Heavy Duty	1800	72	2.69	3.52	2320	5115	K110	
			Severe Duty	1550	61	2.14	2.80	2264	4491	K130	
			Severe Duty Power	1750	70	2.40	3.14	2378	5243	K110	
			Extreme Duty Power	1550	61	2.00	2.59	2440	5379	K130	
			Dedicated	Severe Duty	1650	66	2.41	3.16	2235	4927	K110
349D2	TB	Pin-On/ Pin Grabber	Heavy Duty	1800	72	2.69	3.52	2320	5115	K110	
			Severe Duty	1550	61	2.14	2.80	2264	4491	K130	
			Severe Duty Power	1750	70	2.40	3.14	2378	5243	K110	
			Extreme Duty Power	1550	61	2.00	2.59	2440	5379	K130	
349D2-ME	UB	Pin-On	Severe Duty	1850	73	3.21	4.20	2892	6375	K130	
			Extreme Duty	1550	62	2.61	3.41	3066	6759	K130	
			Dedicated	Severe Duty	1650	65	2.77	3.62	2579	5986	K130
			Extreme Duty	1550	62	2.61	3.41	3011	6638	K130	
374F	WB2	Pin-On	Severe Duty	1800-2200	71-87	3.70-5.00	4.80-6.50	4503-5136	9927- 11,323	K170	
			Extreme Duty	1900-2100	75-83	4.00-4.60	5.25-6.00	5423-5818	11,956- 12,826	K170	
			Dedicated	Severe Duty	1900-2000	75-79	4.00-4.40	5.25-5.75	4638-4795	10,225- 10,571	K170
			Extreme Duty	2000	79	4.40	5.75	5633	12,419	K170	
390F	HB2	Pin-On	General Duty	1100-2000	43-79	2.20-4.60	2.80-6.00	2763-3908	6091-8616	K150	
390F	JC	Pin-On	General Duty	2300-2420	91-95	5.70-6.00	7.40-7.90	5576-5758	12,293- 12,694	K170	
			Heavy Duty	1750	69	4.10	5.30	4635	10,218	K170	
			Severe Duty	2240-2440	88-96	5.40-6.00	7.10-7.90	6438-6878	14,193- 15,163	J800	
			Extreme Duty	2090-2240	82-88	5.00-5.40	6.50-7.10	6186-7362	13,638- 16,230	J800	
			Dedicated	Severe Duty	2240	88	5.40	7.10	6188	13,642	J800

ME = Mass Excavation

Model	Bucket Family	Interface	Bucket Type	Width Range		Capacity Range		Weight Range		GET
				mm	in	m ³	yd ³	kg	lb	
311F 312D2 312E 314E	312	Pin-On	General Duty	600-1200	24-48	0.31-0.76	0.41-0.99	305-479	305-1056	J250
			Heavy Duty	450-1200	18-48	0.20-0.76	0.26-0.99	266-486	586-1071	J250
		CW Dedicated	Severe Duty	900	36	0.53	0.69	444	979	J300
			General Duty	600-1200	24-48	0.31-0.76	0.41-0.99	330-491	728-1082	J250
316E 318D2	315	Pin-On	General Duty	1100-1400	43-55	0.80	1.05	580-686	1279-1512	K80
			Severe Duty	1200	48	0.91	1.19	701	1545	K90
		CW Dedicated	General Duty	600-1400	24-55	0.35-1.09	0.46-1.43	415-667	915-1470	K80
			Heavy Duty	1200-1400	48-55	0.91-1.09	1.19-1.43	623-686	1373-1512	K80
M313D	M313	Pin-On	General Duty	450-1210	18-48	0.20-0.76	0.27-1.00	292-500	644-1102	J250
			Heavy Duty	1200	48	0.76	1.00	509	1122	J250
M315D M316D	M316	Pin-On	General Duty	450-1200	18-48	0.20-0.76	0.27-1.00	330-491	290-1082	J250
			Heavy Duty	500-1200	20-48	0.24-0.76	0.31-1.00	309-501	681-1105	J250
318E	318E	Pin-On	General Duty	750-1400	30-55	0.49-1.09	0.64-1.43	466-686	1027-1512	K80
			Heavy Duty	1300	51	1.00	1.31	673	1484	K80
		CW Dedicated	General Duty	600-1400	24-55	0.35-1.09	0.46-1.43	415-667	915-1470	K80
			Heavy Duty	1200-1400	48-55	0.91-1.09	1.18-1.43	623-686	1374-1512	K80
318D 319D M318D	318	Pin-On	General Duty	600-1400	24-55	0.24-1.13	0.31-1.48	465-723	1025-1594	K80
			Heavy Duty	1200-1400	48-55	0.94-1.13	1.23-1.48	691-757	1523-1669	K80
		CW Dedicated	General Duty	600-1400	24-55	0.35-1.09	0.46-1.43	415-667	915-1470	K80
			Heavy Duty	1200-1300	48-51	0.91-1.09	1.19-1.43	623-686	1373-1512	K80
320D2 320E 320E RR 321D CR 323D2 323E M322D	B	Pin-On	General Duty	600-1400	24-55	0.46-1.43	0.60-1.87	533-841	1175-1854	K80
			Heavy Duty	1200-1400	48-55	1.19-1.30	1.58-1.70	880-928	1940-2046	K90
			Severe Duty	1200	48	1.20	1.57	974	2147	K90
		CW Dedicated	General Duty	900-1300	36-51	0.81-1.30	1.06-1.70	634-775	1398-1709	K80
			Heavy Duty	600-1300	24-51	0.46-1.30	0.60-1.70	591-897	1303-1978	K90
			Severe Duty	1200	48	1.20	1.57	958	2112	K90

Model	Bucket Family	Interface	Bucket Type	Width Range		Capacity Range		Weight Range		GET		
				mm	in	m ³	yd ³	kg	lb			
323D2 324E 328D CR 329E	CB	Pin-On	General Duty	750-1500	30-60	0.71-1.76	0.92-2.30	711-1041	1567-2295	K90		
			Heavy Duty	1350-1500	54-60	1.54-1.76	2.01-2.30	1096-1181	2416-2603	K100		
			Severe Duty	1350	54	1.56	2.04	1207	2661	K100		
		CW Dedicated	General Duty	750-1650	30-66	0.71-1.97	0.92-2.58	614-1058	1354-2332	K90		
			Heavy Duty	750-1650	30-66	0.71-1.97	0.92-2.58	707-1253	1559-2762	K100		
			Severe Duty	1050-1350	42-54	1.13-1.56	1.23-2.04	947-1115	2088-2458	K100		
324E 328D 329E 336E 340D	DB	Pin-On	General Duty	1350-1800	54-72	1.64-2.36	2.15-3.09	1135-1396	2502-3078	K100		
			Heavy Duty	1350-1650	54-66	1.64-2.12	2.15-2.78	1399-1613	3084-3556	K110		
			Severe Duty	1350-1650	54-66	1.66-2.15	2.17-2.81	1528-1767	3368-3896	K110		
		CW Dedicated	General Duty	1350-1650	54-66	1.64-2.12	2.15-2.78	948-1276	2090-2813	K100		
			Heavy Duty	750-1800	30-72	0.73-2.36	0.96-3.09	937-1686	2066-3717	K110		
			Severe Duty	1050-1650	42-66	1.17-2.15	1.53-2.81	1236-1742	2725-3840	K110		
336D 336E 340D	TB	Pin-On	General Duty	1500-1650	60-66	2.14-2.41	2.80-3.15	1824-1967	4021-4336	K110		
			Heavy Duty	1650-1800	66-72	2.41-2.69	3.15-3.52	2150-2284	4740-5035	K110		
			Severe Duty	1350-1650	54-66	1.87-2.41	2.45-3.15	2017-2325	4447-5126	K110		
		CW Dedicated	General Duty	1650	66	2.41	3.15	2059	4539	K110		
			Heavy Duty	1350-1650	54-66	1.87-2.41	2.45-3.15	1926-2235	4246-4927	K110		
			Severe Duty	1350-1650	54-66	1.87-2.41	2.45-3.15	1926-2235	4246-4927	K110		
349E	TB	Pin-On	General Duty	1350	54	1.87	2.45	1707	3763	K110		
			Heavy Duty	1500-1850	60-74	2.14-2.78	2.80-3.64	2017-2348	4447-5176	K110		
			Severe Duty	1550-1900	62-75	2.14-2.78	2.80-3.64	2264-2621	4991-5778	K130		
		CW Dedicated	Heavy Duty	1650	66	2.41	3.15	2136	4709	K110		
			Severe Duty	1350-1650	54-66	1.87-2.41	2.45-3.15	1926-2235	4246-4927	K110		
			Extreme Duty	1350-1650	54-66	1.87-2.41	2.45-3.15	1926-2235	4246-4927	K110		
349D2 349E	UB	Pin-On	General Duty	1450-2000	56-79	2.39-3.60	3.13-4.71	2248-2786	4956-6142	K130		
			Heavy Duty	1650-1950	66-78	2.77-3.43	3.63-4.49	2486-2803	5481-6180	K130		
			Severe Duty	1450-1950	56-78	2.39-3.43	3.13-4.49	2464-2963	5432-6532	K130		
			Extreme Duty	1550-1650	62-66	2.61-2.77	3.42-3.63	3015-3116	6647-6870	K130		
		CW Dedicated	Heavy Duty	1650-1850	66-74	2.77-3.21	3.63-4.20	2403-2568	5298-5661	K130		
			Severe Duty	1550-1650	62-66	2.61-2.77	3.42-3.63	2494-2579	5498-5686	K130		
374D	VB2	Pin-On	General Duty	1900	75	3.80	5.00	3498	7711	K150		
			Heavy Duty	1900	75	3.80	5.00	3658	8064	K150		
374D	WB2	Pin-On	General Duty	2000-2100	79-83	4.60-5.00	6.00-6.50	3892-4012	8580-8845	K150		
			Heavy Duty	2100-2250	83-89	5.00-5.30	6.50-7.00	4190-4436	9237-9780	K150		
			Severe Duty	1800-2200	71-87	3.70-5.00	4.80-6.50	4503-5136	9927-11,323	K170		
			Extreme Duty	1900-2200	75-87	4.00-5.00	5.38-6.41	5423-6007	11,956-13,243	K170		
		CW Dedicated	Severe Duty	1900-2000	75-79	4.00-4.40	5.25-5.75	4638-4795	10,225-10,571	K170		
			Extreme Duty	2000	79	4.40	5.75	5633	12,419	K170		
390D	HB2	Pin-On	General Duty	1100-2200	43-87	2.20-6.00	2.80-8.00	2763-4610	6091-10,163	K170		
			JC	Pin-On	General Duty	2300-2420	91-95	5.70-6.00	7.40-7.90	5576-5758	12,293-12,694	K170
					Heavy Duty	1750	69	4.10	5.30	4635	10,218	K170
	Severe Duty	2240-2440			88-96	5.40-6.00	7.10-7.90	6438-6878	14,193-15,163	J800		
	JC	Pin-On	Extreme Duty	2090-2350	82-93	5.00-5.70	6.50-7.50	6186-7595	13,638-16,744	J800		
			CW Dedicated	Severe Duty	2150-2350	84-93	5.00-5.70	6.50-7.50	5872-6394	12,946-14,096	J800	

Model	Bucket Family	Interface	Bucket Type	Width Range		Capacity Range		Weight Range		GET
				mm	in	m ³	yd ³	kg	lb	
311F 312D2 312E 314E	312	Pin-On/ Pin Grabber	General Duty	458-1067	18-42	0.25-0.65	0.33-0.85	259-460	571-2368	J250/ K80 BOCE
			Ditch Cleaning	1500	59	0.97	1.27	565	1246	
316E M313D M315D M316D	315	Pin-On/ Pin Grabber	General Duty	617-1200	24-48	0.35-0.91	0.45-1.19	388-619	855-1365	K80
			Severe Duty	1050	42	0.76	1.00	666	1469	J350
			Ditch Cleaning	1500-1677	59-66	0.88-1.26	1.15-1.38	608-614	1340-1354	BOCE
318E M318D	B	Pin-On/ Pin Grabber	Heavy Duty	616-1230	24-48	0.44-1.07	0.57-1.40	595-850	1312-1873	K90
			General Duty	1050-1200	42-48	0.76-0.91	1.00-1.19	584-640	1287-1411	K80
320D LR 320E LR 323D2 324E LR	A	Pin-On	Ditch Cleaning	1830	72	0.57	0.75	289	637	none
320E 321D CR 323D2	B	Pin-On/ Pin Grabber	General Duty	600-1500	24-60	0.46-1.58	0.61-2.05	529-877	1166-1933	K80/ J350
			Heavy Duty	610-1500	24-60	0.46-1.58	0.61-2.06	609-1031	1342-2273	K90/ J350
			Severe Duty	600-1250	24-49	0.46-1.20	0.61-1.57	674-1012	1485-2230	K90/ J400
			Ditch Cleaning	1830	72	1.25	1.62	854	1883	BOCE
323D2 324E 329E	CB	Pin-On/ Pin Grabber	General Duty	600-1500	24-60	0.52-1.76	0.68-2.30	639-1041	1409-2295	K90
			Heavy Duty	610-1676	24-66	0.53-1.99	0.69-2.60	770-1340	1698-2954	K100
			Severe Duty	1067	66	1.14	1.50	1111	2450	K100
			Ditch Cleaning	1830	72	1.53	2.00	983	2167	BOCE
324E 329E 336E 340D	DB	Pin-On/ Pin Grabber	Heavy Duty	762-1829	30-72	0.74-2.34	0.97-3.06	1020-1806	2250-3982	K110/ K100
			Severe Duty	1219	48	1.41	1.84	1511	3331	K110
			Ditch Cleaning	1830	72	1.91	2.49	1178	2597	BOCE
336E 340D 349D2 349E	TB	Pin-On/ Pin Grabber	Heavy Duty	914-1880	36-74	1.06-2.68	1.38-3.50	1512-2360	3333-5203	K110
			Severe Duty	1372	54	1.81	2.37	2024	4462	K130
349D2 349E-ME	UB	Pin-On/ Pin Grabber	General Duty	1981	78	3.47	4.5	2762	5891	K130

ME = Mass Excavation

Model	Bucket Family	Interface	Bucket Type	Width Range		Capacity Range		Weight Range		GET
				mm	in	m ³	yd ³	kg	lb	
374D	VB2	Pin-On/ Pin Grabber	General Duty	1525	60	2.9	3.9	3081	6792	K150
			Severe Duty	1700	66	3.3	4.3	3529	7780	K150
374D	WB2	Pin-On	Severe Duty	2100	83	4.6	6.0	4977	10,972	K170
			Extreme Duty	2050-2150	80-85	4.4-4.6	5.75-6.0	5671-5818	12,502-12,826	K170
		CW Dedicated	Severe Duty	1900-2000	75-79	4.0-4.4	5.25-5.75	4638-4795	10,225-10,571	K170
			Extreme Duty	2000	79	4.4	5.75	5633	12,419	K170
390D	HB2	Pin-On	General Duty	1685-1910	66-75	3.9-4.6	5.1-6.0	3670-4000	8091-8818	K150
390D	JC	Pin-On	General Duty	2420	95	6.0	7.9	5752	12,681	K170
			Heavy Duty	2090-2300	82-91	5.1-5.7	6.6-7.4	5236-5646	11,543-12,447	K170
			Severe Duty	2240	88	5.4	7.1	6440	14,198	J800
			Extreme Duty	2090-2240	82-88	5.0-5.4	6.5-7.1	6186-7362	13,638-16,230	J800
	CW Dedicated	Severe Duty	2240-2350	88-93	5.4-5.7	7.1-7.50	6188-6394	13,642-14,096	J800	

Model	Bucket Family	Interface	Bucket Type	Width Range		Capacity Range		Weight Range		GET
				mm	in	m ³	yd ³	kg	lb	
312D2 GC 313D2	312	Pin-On	Utility Duty	911	36	0.53	0.69	423	932	J250
			General Duty	1085	43	0.65	0.84	493	1087	J250
			Severe Duty	1087	43	0.65	0.84	559	1232	J300
318D2	315	Pin-On	General Duty	1100	43	0.80	1.04	598	1318	J300
			Severe Duty	1050	42	0.76	1.00	666	1496	J350
320D2 323D2	B	Pin-On	Utility Duty	1121-1274	44-50	0.80-1.00	1.04-1.31	736-853	1622-1881	J350
			General Duty	1279-1419	50-56	1.00-1.14	1.31-1.49	816-882	1800-1944	J350
			Heavy Duty	1096-1400	43-55	1.00-1.34	1.31-1.75	928-1052	2046-2319	J350
			Severe Duty	1093-1244	43-49	1.00-1.19	1.31-1.56	1043-1142	2300-2518	J400
323D2	CB	Pin-On	Severe Duty	1244	49	1.19	1.56	1142	2518	J460
			Extreme Duty	1250	49	1.33	1.74	1320	2910	J460
326D2 329D2	CB	Pin-On	General Duty	1400	55	1.54	2.02	1058	2333	J400
			Heavy Duty	1250-1400	49-55	1.33-1.54	1.74-2.02	1072-1163	2363-2564	J400
			Severe Duty	1252-1400	50-56	1.33-1.54	1.74-2.02	1197-1307	2639-2882	J460
326D2-ME 329D2-ME	DB	Pin-On	Heavy Duty	1395	55	1.64	2.14	1528	3086	J460
			Severe Duty	1239	49	1.40	1.84	1654	3086	J550
			Extreme Duty	1261	50	1.40	1.84	1757	3661-1756	J550
336D 340D	DB	Pin-On	Heavy Duty	1395-1547	55-61	1.64-1.88	2.14-2.46	1528-1621	3369-3574	J460
			Severe Duty	1413-1570	56-62	1.64-1.90	2.14-2.46	1766-1910	3893-4211	J550
			Extreme Duty	1413	56	1.64	2.14	1852	4083	J550
336E 340D	TB	Pin-On	General Duty	1500	60	2.14	2.80	1900	4189	J550
			Heavy Duty	1734-1850	68-73	2.12-2.69	2.77-3.52	1715-2543	3781-5606	J550
			Severe Duty	1570-1722	62-68	2.14-2.41	2.80-3.16	2290-2541	5050-6690	J550
349D2	TB	Pin-On	General Duty	1650	66	2.41	3.16	2198	4846	J550
			Severe Duty	1570-1864	62-73	2.14-3.21	2.09-3.16	2290-3034	5050-6690	J550
349D2-ME	UB	Pin-On	General Duty	1550	62	2.61	3.41	2272	5009	J550
			Severe Duty	1589-1864	63-73	2.61-3.21	3.41-4.20	2701-3034	5955-6690	J550
374D	VB2	Pin-On	General Duty	1525	60	2.90	3.90	3081	6792	K150
			Severe Duty	1700	66	3.30	4.30	3529	7780	K150
374D	WB2	Pin-On	Severe Duty	2220	87	4.60	6.00	5316	11,720	K170/ J700
			Extreme Duty	2220-2300	87-91	4.40-4.60	5.75-6.00	5868-6028	12,937-13,289	K170
390D	HB2	Pin-On	General Duty	1650-1900	66-75	3.90-4.60	5.10-6.00	3670-4000	8091-8818	K150
390D	JC	Pin-On	General Duty	2300-2420	91-95	5.70-6.00	7.40-7.90	5576-5758	12,293-12,694	K170
			Heavy Duty	2090-2300	82-91	5.10-5.70	6.60-7.40	5236-5646	11,543-12,447	K170
			Severe Duty	2040-2510	80-99	4.60-6.00	6.00-7.90	6329-7442	13,953-16,410	J800
	CW Dedicated	Severe Duty	2240-2350	88-93	5.40-5.70	7.10-7.50	6188-6394	13,642-14,096	J800	

ME = Mass Excavation

EXCAVATOR BUCKET CAPACITIES

Caterpillar rates excavator buckets to conform with both PCSA standard No. 3 and SAE standard J-296. Buckets are rated on both their struck and heaped capacities as follows:

Struck Capacity

Volume actually enclosed inside the outline of the sideplates and rear and front bucket enclosures without any consideration for any material supported or carried by the spillplate or bucket teeth.

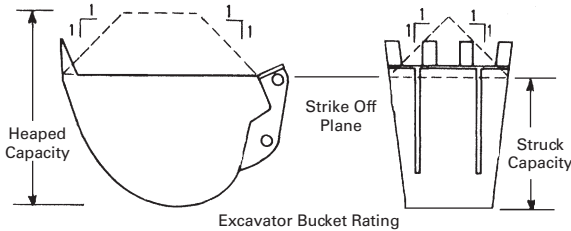

Heaped Capacity

Volume in the bucket under the strike off plane plus the volume of the heaped material above the strike off plane, having an angle of repose of 1:1 without any consideration for any material supported or carried by the spillplate or bucket teeth.

The Committee on European Construction Equipment (CECE) rates heaped bucket pay loads on a 2:1 angle of repose for material above the strike off plane.

CURL AND CROWD FORCES

Bucket penetration into a material is achieved by the bucket curling force (F_B) and stick crowd force (F_S). Rated digging forces are the digging forces that can be exerted at the outermost cutting point. These forces can be calculated by applying working relief hydraulic pressure to the cylinder(s) providing the digging force. The digging forces listed on next page conform with SAE Standard J1179 and PCSA Standard No. 3. The values may not be directly comparable to forces for machines rated by other methods than those described below.

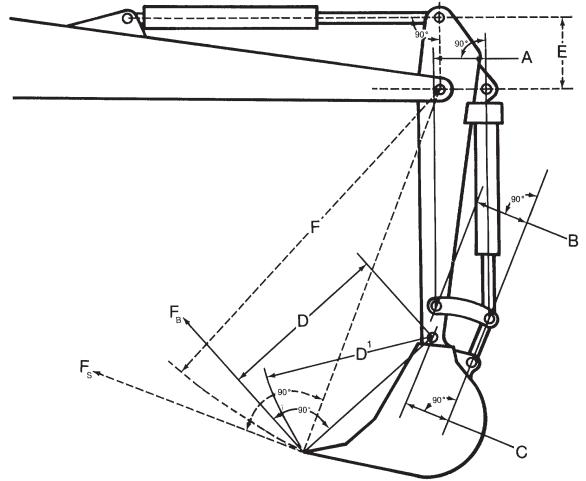

$$F_B = \text{Radial tooth force due to bucket cylinder} = \frac{\text{Bucket cylinder force}}{\text{Arm D length}} \left(\frac{\text{Arm A} \times \text{Arm C}}{\text{Arm B}} \right)$$

$$\text{Cylinder force} = (\text{Pressure}) \times (\text{End area of cylinder head})$$

$$\text{Arm D} = \text{Bucket tip radius}$$

Maximum radial tooth force due to bucket cylinder (bucket curling force) is the digging force generated by the bucket cylinder(s) and tangent to the arc of radius D' . The bucket shall be positioned to obtain maximum output moment from the bucket cylinder(s) and connecting linkages. When calculating, maximum F_B occurs when the factor — Arm A times Arm C divided by Arm B — becomes the maximum.

$$F_S = \text{Radial tooth force due to stick cylinder} = \frac{(\text{Stick cylinder force}) \times (\text{Arm E length})}{(\text{Arm F length})}$$

$$\text{Arm F} = \text{Bucket tip radius} + \text{stick length}$$

Maximum radial tooth force due to stick cylinder (stick crowd force) is the digging force generated by the stick cylinder(s) and tangent to the arc of radius F . The stick shall be positioned to obtain the maximum output moment from the arm cylinder and the bucket positioned as described in the bucket force rating. When calculating, maximum F_S occurs when the axis in the stick cylinder working direction is at a right angle to the line connecting the stick cylinder pin and the boom nose pin.

Bucket Selection Considering Bucket Curl and Stick Crowd Forces

The combination of the excavator's stick crowd force and bucket curling force give this machine configuration more effective bucket penetration force per mm (inch) of bucket cutting edge than is available with other machine types such as wheel and track loaders.

As a result of high penetration force, an excavator bucket is comparatively easy to load. Also, the higher unit breakout forces allow the excavator's economic application range to be extended farther into the tougher soils (coral, caliche, shale, limestone) before blasting or ripping is required.

To take full advantage of an excavator's high penetration forces, buckets should be selected so they are well matched to soil conditions that are encountered. The two important things to consider are bucket width and bucket tip radius.

As a general rule, wide buckets are used in easily dug soil and narrow buckets in harder material. In hard rocky soils, tip radius also has to be considered in bucket selection. Because the shorter tip radius buckets provide more total bucket curling force than the long tip radius buckets, they are generally the easiest to load. A good rule of thumb when selecting a Cat bucket for hard material is to choose the narrowest bucket that has a short tip radius.

Other factors such as trench bottom width specifications, manbox size, or the desire to conserve bedding material may also influence excavator bucket selection.

NOTE: See the following pages for listing of Cat buckets by tip radius and cutting edge width.

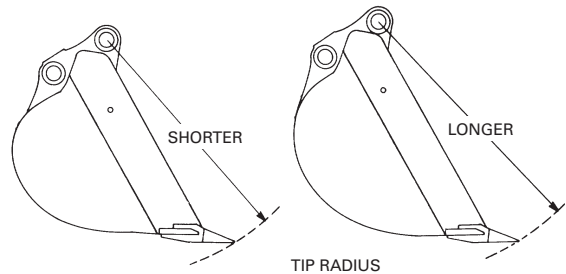

Model	Source	Bucket Tip Radius		Bucket Curling Forces		Stick Crowd Forces							
						Short		Medium		Long		Extra Long	
		mm	ft	kN	lb	kN	lb	kN	lb	kN	lb	kN	lb
300.9D	Austria	443	1'5"	8.9	2000	—	—	—	—	4.5	1011	—	—
301.4C	Austria	500	1'7"	15.4	3462	—	—	—	—	7.1	1596	—	—
301.7D	Austria	500	1'7"	18.8	4226	11.2	2518	—	—	9.8	2203	—	—
301.7D CR	Austria	500	1'7"	14.2	3190	8.4	1890	—	—	7.3	1640	—	—
302.2D	Austria	—	—	19.6	4406	12.6	2810	—	—	11.0	2473	—	—
302.4D	Austria	650	2'2"	21.8	4900	15.0	3372	—	—	13.3	2990	—	—
302.7D CR	Austria	650	2'1"	22.5	5058	—	—	15.4	3462	13.6	3057	—	—
303E CR	Japan	711	2'4"	28.4	6385	—	—	16.6	3732	—	—	—	—
303.5E CR	Japan	711	2'4"	33	7420	—	—	18.9	4250	16.9	3799	—	—
303.5E2 CR	United States	711	2'4"	33	7420	—	—	18.9	4250	16.9	3799	—	—
304E2 CR	United States	711	2'4"	37.8	8500	—	—	21.6	4860	19.5	4385	—	—
305E2 CR	United States	786	2'7"	44.7	10,049	—	—	24.7	5553	21.3	4788	—	—
305.5E2 CR	United States	786	2'7"	50.9	11,443	—	—	28.9	6497	24.8	5575	—	—
307E2	China	1014	3'4"	50.6	11,375	—	—	37.1	8340	—	—	—	—
308E2 CR SB	United States	1014	3'3"	60	13,489	—	—	39	8768	—	—	—	—
311D LRR	Japan	1220	4'0"	90	20,175	—	—	60	13,560	55	12,270	52	11,690
312D, 312D L	Japan	1220	4'0"	85	19,100	—	—	64	14,400	60	13,500	57	12,800
312D, 312D L	France	1000	3'3"	96	21,600	66	14,850	62	13,950	59	13,275	—	—
313C SR	Japan	1220	4'0"	88	19,780	—	—	63	14,160	—	—	—	—
313C CR	Japan	1220	4'0"	94	21,120	—	—	64	14,380	57	12,810	—	—
314D CR, 314D LCR	Japan	1220	4'0"	85	19,100	—	—	64	14,400	60	13,500	57	12,800

**Japan Sourced
315D L**

Boom		1-Piece Boom			
Stick		Short	Medium	Long	Extra Long
Bucket Tip Radius	mm	1350	1350	1350	1350
	ft	4'5"	4'5"	4'5"	4'5"
Bucket Curling Forces	kN	100	100	100	100
	lb	22,530	22,530	22,530	22,530
Stick Crowd Forces	kN	85	78	73	70
	lb	19,200	17,470	16,410	15,670

**Japan Sourced
315D L (EAME)**

Boom		1-Piece Boom			
Stick		Short	Medium	Long	Extra Long
Bucket Tip Radius	mm	1117	1117	1117	1117
	ft	3'7"	3'7"	3'7"	3'7"
Bucket Curling Forces	kN	102	90	82	74
	lb	22,930	20,230	18,430	16,630
Stick Crowd Forces	kN	98	80	69	62
	lb	22,030	17,980	15,510	13,930

7

319D L, 319D LN

Boom		1-Piece Boom			
Stick		Short	Medium	Long	Extra Long
Bucket Tip Radius	mm	1461	1461	1461	1461
	ft	4'10"	4'10"	4'10"	4'10"
Bucket Curling Forces	kN	148	146	124	126
	lb	33,300	32,850	27,900	28,350
Stick Crowd Forces	kN	125	108	92	83
	lb	28,125	24,300	20,700	18,675

M313D

Boom		1-Piece/VA Boom			
Stick		2300 mm	7'5"	2600 mm	8'6"
Bucket Tip Radius	mm	1236		1236	
	ft	4'1"		4'1"	
Bucket Curling Forces	kN	93		93	
	lb	20,925		20,925	
Stick Crowd Forces	kN	67		62	
	lb	15,075		13,950	

M315D, M316D

Boom		1-Piece/VA Boom			
Stick		2400 mm	7'10"	2600 mm	8'6"
Bucket Tip Radius	mm	1405		1405	
	ft	4'7"		4'7"	
Bucket Curling Forces	kN	101		101	
	lb	22,725		22,725	
Stick Crowd Forces	kN	74		71	
	lb	16,650		15,975	

M318D

Boom		1-Piece/VA Boom			
Stick		2500 mm	8'2"	2800 mm	9'2"
Bucket Tip Radius	mm	1405		1405	
	ft	4'7"		4'7"	
Bucket Curling Forces	kN	126		126	
	lb	28,350		28,350	
Stick Crowd Forces	kN	91		85	
	lb	20,475		19,125	

M322D

Boom		1-Piece/VA Boom			
Stick		2500 mm	8'2"	2900 mm	9'6"
Bucket Tip Radius	mm	1511		1511	
	ft	4'11"		4'11"	
Bucket Curling Forces	kN	140		140	
	lb	31,500		31,500	
Stick Crowd Forces	kN	114		104	
	lb	25,650		23,400	

**Africa/Middle East Sourced
320D2, 320D2 L**

Boom		Reach Boom	
Stick		Medium (R2.5B)	Long (R2.9B)
Bucket Tip Radius	mm	1554	1554
	ft	5'1"	5'1"
Bucket Curling Forces	kN	141	141
	lb	31,725	31,725
Stick Crowd Forces	kN	118	106
	lb	26,650	23,850

**Japan/China/Indonesia/Brazil Sourced
320D2, 320D2 L**

Boom		Reach Boom			Mass Boom
Stick		Medium (R2.5B)	Long (R2.9B)	Extra Long (R3.9B)	Medium
Bucket Tip Radius	mm	1477	1477	1477	1555
	ft	4'10"	4'10"	4'10"	4'11"
Bucket Curling Forces	kN	131	131	131	166
	lb	29,450	29,450	29,450	37,318
Stick Crowd Forces	kN	117	105	86	125
	lb	26,303	23,605	19,334	28,100

**Japan Sourced
321D LCR**

Boom		Reach Boom
Stick		Long
Bucket Tip Radius	mm	1477
	ft	4'10"
Bucket Curling Forces	kN	131
	lb	29,450
Stick Crowd Forces	kN	105
	lb	23,605

**Brazil Sourced
323D2 L**

Boom		Reach Boom		
Stick		R1.9CB	R2.5B1	R2.9B1
Bucket Tip Radius	mm	1610	1554	1554
	ft	5'3"	5'1"	5'1"
Bucket Curling Forces	kN	179	141	141
	lb	40,275	31,725	31,725
Stick Crowd Forces	kN	147	118	106
	lb	33,075	26,550	26,650
Boom		Mass Boom		
Stick		M2.4CB2		
Bucket Tip Radius	mm	1610		
	ft	5'3"		
Bucket Curling Forces	kN	188		
	lb	42,300		
Stick Crowd Forces	kN	130		
	lb	29,250		
Boom		VA Boom		
Stick		R1.9CB	R2.5B1	R2.9B1
Bucket Tip Radius	mm	1610	1554	1554
	ft	5'3"	5'1"	5'1"
Bucket Curling Forces	kN	179	141	141
	lb	40,275	31,725	31,725
Stick Crowd Forces	kN	147	118	106
	lb	33,075	26,550	26,650

**China Sourced
323D2 L**

Boom		Reach Boom	
Stick		R2.5B1	R2.9B1
B1360HD-CXL			
Bucket Tip Radius	mm	1579	
	ft	5'2"	
Bucket Curling Forces	kN	140.4/124.9	
	lb	31,563/28,079	
Stick Crowd Forces	kN	117.9/113.9	
	lb	26,505/25,606	
Boom		Mass Boom	
Stick		M2.4CB2	
Bucket Tip Radius	mm	1683	
	ft	5'6"	
Bucket Curling Forces	kN	174.2/155.1	
	lb	39,162/34,868	
Stick Crowd Forces	kN	126.4/121.7	
	lb	28,416/27,359	

**Japan/U.S. Sourced
326D2**

Boom		Reach Boom		
Stick		Medium	Long	Extra Long
Bucket Tip Radius	mm	1551	1551	1477
	ft	5'1"	5'1"	4'10"
Bucket Curling Forces	kN	186	186	172
	lb	41,814	41,814	38,667
Stick Crowd Forces	kN	148	127	113
	lb	33,272	28,551	25,471
Boom		Mass Boom		
Stick		Short	Medium	
Bucket Tip Radius	mm	1663	1663	
	ft	5'5"	5'5"	
Bucket Curling Forces	kN	189	239	
	lb	42,470	53,729	
Stick Crowd Forces	kN	151	147	
	lb	33,930	33,047	

7

**Japan/U.S. Sourced
328D LCR**

Boom		Reach Boom	
Stick		Short	Medium
Bucket Tip Radius	mm	1660	1487
	ft	5'5"	4'11"
Bucket Curling Forces	kN	201	200
	lb	45,187	44,962
Stick Crowd Forces	kN	152	133
	lb	34,171	29,900

**Japan/U.S. Sourced
329D2**

Boom		Reach Boom			
Stick		Short	Medium	Long	Extra Long
Bucket Tip Radius	mm	1660	1487	1487	1488
	ft	5'5"	4'11"	4'11"	4'11"
Bucket Curling Forces	kN	201	200	201	160
	lb	45,187	44,962	45,187	36,000
Stick Crowd Forces	kN	152	133	120	124
	lb	34,171	29,900	26,977	27,900
Boom		Mass Boom			
Stick		Medium			
Bucket Tip Radius	mm	1660			
	ft	5'5"			
Bucket Curling Forces	kN	239			
	lb	53,729			
Stick Crowd Forces	kN	162			
	lb	36,419			

**Japan/U.S. Sourced
336D**

Boom		Reach Boom			
Stick		Short	Medium	Long	Extra Long
Bucket Tip Radius	mm	1845	1660	1660	1660
	ft	6'0"	5'5"	5'5"	5'5"
Bucket Curling Forces	kN	238	238	190	191
	lb	53,437	53,572	42,700	42,900
Stick Crowd Forces	kN	170	152	161	140
	lb	38,218	34,148	36,200	31,500
Boom		Mass Boom			
Stick		M2.6E			
Bucket Tip Radius	mm	1845			
	ft	6'1"			
Bucket Curling Forces	kN	271			
	lb	60,923			
Stick Crowd Forces	kN	195			
	lb	43,883			

**Belgium Sourced
336D L**

Boom		Reach Boom			
Stick		R2.1TB	R2.8DB	R3.2DB	R3.9DB
Bucket Tip Radius	mm	1897	1761	1761	1761
	ft	6'3"	5'9"	5'9"	5'9"
Bucket Curling Forces	kN	249	204	194	184
	lb	56,025	45,900	43,650	41,400
Stick Crowd Forces	kN	235	194	177	158
	lb	52,875	43,650	39,825	35,550
Boom		Mass Boom			
Stick		M2.15TB		M2.6TB	
Bucket Tip Radius	mm	1897		1897	
	ft	6'3"		6'3"	
Bucket Curling Forces	kN	249		233	
	lb	56,025		52,425	
Stick Crowd Forces	kN	235		208	
	lb	52,875		46,800	

**Japan Sourced
349D2 per SAE**

Boom		Reach Boom		
Stick		Short	Medium	Long
Bucket Tip Radius	mm	1725	1725	1725
	ft	5'8"	5'8"	5'8"
Bucket Curling Forces	kN	258	258	258
	lb	58,000	58,000	58,000
Stick Crowd Forces	kN	220	201	186
	lb	49,500	45,100	41,800
Boom		Mass Boom		
Stick		Short	Medium	
Bucket Tip Radius	mm	2050	2050	
	ft	6'9"	6'9"	
Bucket Curling Forces	kN	203	203	
	lb	45,680	45,680	
Stick Crowd Forces	kN	228	203	
	lb	51,300	45,680	

7

**Japan Sourced
349D2**

Boom		Reach Boom		
Stick		Short	Medium	Long
Bucket Tip Radius	mm	1820	1820	1820
	ft	6'0"	6'0"	6'0"
Bucket Curling Forces	kN	234	234	234
	lb	52,580	52,580	52,580
Stick Crowd Forces	kN	216	197	183
	lb	48,540	44,270	41,120
Boom		Mass Boom		
Stick		Medium	Long	
Bucket Tip Radius	mm	2020	2020	
	ft	6'8"	6'8"	
Bucket Curling Forces	kN	263	263	
	lb	59,100	59,100	
Stick Crowd Forces	kN	230	204	
	lb	51,690	45,840	

**Japan/U.S. Sourced
349D2 L – FIX**

Boom		Long Reach Boom		
Stick		Long		Extra Long
Bucket Tip Radius	mm	1820		1820
	ft	6'0"		6'0"
Bucket Curling Forces	kN	234		235
	lb	52,580		52,810
Stick Crowd Forces	kN	183		170
	lb	41,120		38,200
Boom		Reach Boom		
Stick		Short	Medium	Long
Bucket Tip Radius	mm	1820	1820	1820
	ft	6'0"	6'0"	6'0"
Bucket Curling Forces	kN	234	234	234
	lb	52,580	52,580	52,580
Stick Crowd Forces	kN	216	197	183
	lb	48,540	44,270	41,120
Boom		Mass Boom		
Stick		Medium		Long
Bucket Tip Radius	mm	2020		2020
	ft	6'8"		6'8"
Bucket Curling Forces	kN	263		263
	lb	59,100		59,100
Stick Crowd Forces	kN	230		204
	lb	51,690		45,840

**Japan Sourced
349E L per ISO**

Boom		Reach Boom			Mass Boom	
Stick		R2.9TB	R3.35TB	R3.9TB	M2.5UB	M3.0UB
Bucket Tip Radius	mm	1865	1865	1865	2057	2057
	ft	6'1"	6'1"	6'1"	6'9"	6'9"
Bucket Curling Forces	kN	268	268	268	296	296
	lb	60,250	60,250	60,250	66,540	66,540
Stick Crowd Forces	kN	221	201	184	241	212
	lb	49,680	45,190	41,360	54,180	47,660

**Belgium Sourced
349E L per ISO**

Boom		Reach Boom		Mass Boom	
Stick		R2.9TB	R3.35TB	M2.5UB	M3.0UB
Bucket Tip Radius	mm	1865	1865	2093	2093
	ft	6'1"	6'1"	6'10"	6'10"
Bucket Curling Forces	kN	268	268	292	292
	lb	60,250	60,250	65,640	65,640
Stick Crowd Forces	kN	221	201	240	211
	lb	49,680	45,190	53,950	47,430

7

**U.S. Sourced
349F L per ISO**

Boom		Reach Boom		Long Reach Boom	Mass Boom	
Stick		R3.35TB	R3.9TB	R4.3TB	M2.5UB	M3.0UB
Bucket Tip Radius	mm	1865	1865	1866	2057	2057
	ft	6'1"	6'1"	6'1"	6'9"	6'9"
Bucket Curling Forces	kN	268	268	267	296	296
	lb	60,250	60,250	60,020	66,540	66,540
Stick Crowd Forces	kN	201	184	170	241	212
	lb	45,190	41,360	38,220	54,180	47,660

**Belgium Sourced
365C L per ISO**

Boom		7.80 m (25'7") Reach Boom			
Stick		R2.84VB	R3.6VB	R4.15VB	R4.67VB
Bucket Tip Radius	mm	1903	1862	1862	1862
	ft	6'2"	5'9"	5'9"	5'9"
Bucket Curling Forces	kN	295	284	271	264
	lb	66,380	63,900	60,980	59,400
Stick Crowd Forces	kN	287	265	243	229
	lb	64,580	59,630	54,680	51,530
Boom		6.6 m (21'8") Mass Boom		7 m (23'0") Mass Boom	
Stick		M2.57WB	M3.0WB	M2.57WB	M3.0WB
Bucket Radius at Cutting Edge	mm	2015	2015	2015	2015
	ft	6'6"	6'6"	6'6"	6'6"
Bucket Force	kN	332	321	332	321
	lb	74,700	72,230	74,700	72,230
Stick Force	kN	309	289	309	288
	lb	69,530	65,030	69,530	64,800

**Belgium Sourced
385C/385C L per ISO**

Boom		Reach Boom 10 m (32'10")			
Stick		R4.4HB		R5.5HB	
Bucket Radius at Cutting Edge	mm	1959		1959	
	ft	6'5"		6'5"	
Bucket Digging Force	kN	335		316	
	lb	75,380		71,100	
Stick Digging Force	kN	293		256	
	lb	65,930		57,600	
Boom		General Purpose Boom 8.4 m (27'7")			
Stick		G3.4JB	G4.4HB	G5.5HB	
Bucket Radius at Cutting Edge	mm	2175	1959	1959	
	ft	7'2"	6'5"	6'5"	
Bucket Digging Force	kN	384	334	315	
	lb	86,400	75,150	70,880	
Stick Digging Force	kN	342	293	257	
	lb	76,950	65,930	57,830	
Boom		Mass Boom 7.25 m (23'9")			
Stick		M2.92JB		M3.4JB	
Bucket Radius at Cutting Edge	mm	2233		2233	
	ft	7'4"		7'4"	
Bucket Digging Force	kN	394		385	
	lb	88,650		86,630	
Stick Digging Force	kN	362		344	
	lb	81,450		77,400	

Caterpillar offers a very comprehensive list of high strength steel buckets. High strength steel allows thinner components which helps keep the weight down, maintains durability and improves loadability. The wrong bucket can reduce production 30-40% or more. Caterpillar's in-depth knowledge of machine design, bucket design

and application experience allows offering **machine matched** packages that optimize performance.

Additional buckets may be available and the listed buckets may not be available in all sales areas. Contact your Cat dealer for your specific bucket needs.

Model	Bucket Type	Teeth	Bucket Bite Width		Rated Capacity ¹ (Heaped)		Weight ² Calculated		Tip Radius	
			mm	in	m ³	ft ³	lb	kg	mm	in
300.9D	Digging	3	250	9.8	0.014	0.494	33.0	14.8	432.0	17.0
		3	370	14.6	0.018	0.636	38.0	17.2	432.0	17.0
	Ditch Cleaning	0	700	27.6	0.027	0.950	54.0	24.5	326.0	12.8
301.4C, 301.7D, 301.7D CR	Digging	3	230	9.0	0.018	0.620	64.6	29.4	500.0	20.0
		3	300	12.0	0.022	0.780	68.5	31.1	500.0	20.0
		3	400	16.0	0.033	1.160	77.8	35.4	500.0	20.0
		3	457	18.0	0.040	1.400	83.3	37.9	500.0	20.0
		4	500	20.0	0.045	1.590	90.1	40.9	500.0	20.0
	Ditch Cleaning	4	600	24.0	0.056	1.970	100.0	45.4	500.0	20.0
		0	800	32.0	0.042	1.500	89.1	40.5	355.0	14.0
	Tilting Ditch Cleaning	0	1000	40.0	0.057	2.000	93.5	42.5	355.0	14.0
0		1000	40.0	0.055	1.900	167.0	76.0	491.0	19.3	
Mud*	0	1000	40.0	0.088	3.110	123.0	56.0	446.0	17.6	
302.2D, 302.4D, 302.7D CR	Digging	3	260	10.0	0.027	0.970	103.3	46.9	590.5	23.2
		3	300	12.0	0.034	1.210	100.6	45.6	590.5	23.2
		3	400	16.0	0.045	1.590	111.0	50.4	590.5	23.2
		3	457	18.0	0.053	1.890	118.7	53.9	590.5	23.2
		4	500	20.0	0.060	2.110	129.0	58.5	590.5	23.2
		4	600	24.0	0.076	2.690	142.7	64.7	590.5	23.2
	Ditch Cleaning	4	700	28.0	0.092	3.250	156.3	70.9	590.5	23.2
		0	800	32.0	0.080	2.800	179.0	81.4	478.0	18.8
		0	1000	40.0	0.102	3.600	172.0	78.2	478.0	18.8
	Tilting Ditch Cleaning	0	1200	47.0	0.116	4.100	193.0	87.7	478.0	18.8
		0	1100	43.0	0.110	3.880	293.0	133.0	650.0	25.6
Mud*	0	1000	40.0	0.173	6.110	172.0	78.0	595.0	23.4	
303E CR, 303.5E CR, 303.5E2 CR, 304E CR, 304E2 CR	Ditch Cleaning	0	1000	40.0	0.130	4.800	240.0	109.0	545.0	21.5
		0	1200	47.0	0.160	5.900	235.0	107.0	545.0	21.5
		0	1400	55.0	0.197	6.960	259.0	118.0	545.0	21.5
	Heavy Duty	3	305	12.0	0.050	1.700	139.0	63.0	737.0	29.0
		3	406	16.0	0.070	2.500	158.0	72.0	737.0	29.0
		4	457	18.0	0.080	2.900	176.0	80.0	737.0	29.0
		5	508	20.0	0.090	3.300	193.0	88.0	737.0	29.0
		5	610	24.0	0.120	4.200	217.0	99.0	737.0	29.0
		5	762	30.0	0.160	5.600	253.0	115.0	737.0	29.0
	Tilting Ditch Cleaning	6	914	36.0	0.190	7.000	300.0	136.0	737.0	29.0
0		1200	47.0	0.159	5.600	357.0	162.0	725.0	28.5	
Mud*	0	1200	47.0	0.232	8.190	331.0	150.0	628.0	24.7	

¹ Capacities shown as per ISO 7451:1997.

² Weight shown includes standard ground engaging tools.

*Product is available in Australia/New Zealand market ONLY.

Model	Bucket Type	Teeth	Bucket Bite Width		Rated Capacity ¹ (Heaped)		Weight ² Calculated		Tip Radius	
			mm	in	m ³	ft ³	lb	kg	mm	in
305E CR, 305E2 CR, 305.5E CR, 305.5E2 CR	Ditch Cleaning	0	1000	40.0	0.170	6.000	258.0	117.0	584.0	23.0
		0	1300	51.0	0.220	7.800	260.0	118.0	584.0	23.0
		0	1600	63.0	0.280	9.900	306.0	139.0	584.0	23.0
	Heavy Duty	3	305	12.0	0.059	2.100	151.0	69.0	785.0	31.0
		3	406	16.0	0.076	2.700	170.0	77.0	785.0	31.0
		4	457	18.0	0.088	3.100	189.0	86.0	785.0	31.0
		4	508	20.0	0.102	3.600	207.0	94.0	785.0	31.0
		5	610	24.0	0.130	4.600	234.0	106.0	785.0	31.0
		5	762	30.0	0.173	6.100	274.0	125.0	785.0	31.0
	Heavy Duty Capacity	3	305	12.0	0.082	2.900	179.0	81.0	852.0	33.5
		3	406	16.0	0.105	3.700	200.0	91.0	852.0	33.5
		4	457	18.0	0.125	4.400	220.0	100.0	852.0	33.5
		5	508	20.0	0.144	5.100	241.0	110.0	852.0	33.5
		5	610	24.0	0.181	6.400	271.0	123.0	852.0	33.5
		5	762	30.0	0.241	8.500	316.0	144.0	852.0	33.5
	Tilting Ditch Cleaning	0	1600	63.0	0.300	10.600	366.0	166.0	852.0	33.5
		0	1200	47.0	0.260	9.180	357.0	162.0	693.0	27.2
	Mud*	0	1500	59.0	0.330	11.700	428.0	194.0	693.0	27.2
		0	1219	48.0	0.329	11.600	476.0	216.0	791.0	31.1
	307D, 308E CR SB, 308E2 CR SB	Ditch Cleaning	0	1372	54.0	0.375	13.200	516.0	235.0	791.0
0			1524	60.0	0.421	14.900	556.0	253.0	791.0	31.1
0			1500	59.0	0.240	8.500	319.0	145.0	658.0	26.0
0			1800	71.0	0.300	10.600	365.0	166.0	658.0	26.0
0			1219	48.0	0.329	11.600	476.0	216.0	791.0	31.1
Heavy Duty		3	330	13.0	0.100	3.500	275.0	125.0	1015.0	40.0
		4	457	18.0	0.150	5.300	333.0	151.0	1015.0	40.0
		4	610	24.0	0.230	8.100	392.0	178.0	1015.0	40.0
		5	762	30.0	0.310	10.900	455.0	207.0	1015.0	40.0
		5	914	36.0	0.390	13.700	507.0	230.0	1015.0	40.0
Heavy Duty Rock		4	610	24.0	0.230	8.100	427.0	194.0	1015.0	40.0
		5	762	30.0	0.310	10.900	490.0	223.0	1015.0	40.0
Mud*		0	1200	47.0	0.410	14.500	589.0	267.0	894.0	35.2
		0	1500	59.0	0.520	18.400	689.0	313.0	894.0	35.2

¹ Capacities shown as per ISO 7451:1997.

² Weight shown includes standard ground engaging tools.

*Product is available in Australia/New Zealand market ONLY.

NEW NOMENCLATURE FOR HYDRAULIC EXCAVATOR BUCKETS

Caterpillar will soon be moving to a new global nomenclature for buckets on small, medium and large HEX machines and associated linkages. The end result will be a manageable, consistent bucket offering in all regions regardless of where the machine or bucket may be built and shipped. The new bucket designs and nomenclature will be introduced over the next several years, as D and E Series HEX machines are introduced.

Why the change?

Consistent product line

Buckets currently sold into different regions of the world have been designed and manufactured independent of each other resulting in different bucket styles and nomenclature. As Caterpillar becomes more global, we recognize this can lead to confusion in the marketplace as machines and buckets are sourced from different areas.

Improved bucket selection

Caterpillar continues to recognize the need for a range of buckets for various applications and with varying durability requirements — from site development to granite quarries. The new, global nomenclature is simplified, consistent, and based on the durability of the bucket. These considerations allow a clear and consistent bucket positioning to help facilitate appropriate bucket selection and recommendation — and put Caterpillar in a better position to support machines on a global scale.

Dealers and customers in North America will see changes in bucket nomenclature and improvement in bucket designs.

What dealers will see with the change

Today, North American HEX buckets are grouped into three main categories: General Purpose (GP), Heavy Duty (HD), and Heavy Duty Rock (HDR). New nomenclature brings in four primary categories, each represent durability. They are: General Duty (GD), Heavy Duty (HD), Severe Duty (SD), and Extreme Duty (XD). Within the Extreme Duty class a new bucket specific for use in granite will be available for the large excavators.

The diagram below illustrates how today's nomenclature aligns with the new, followed by a brief description of each category.

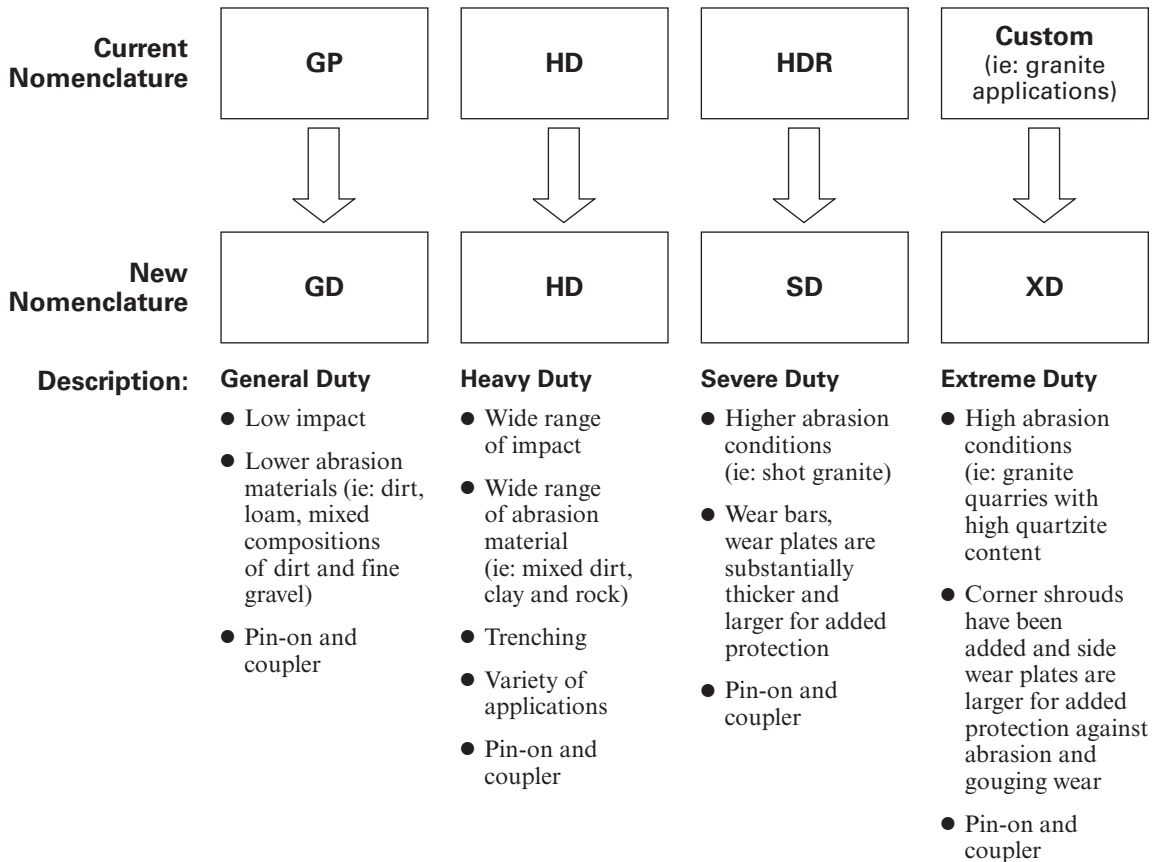

BUCKET TYPES

General Duty

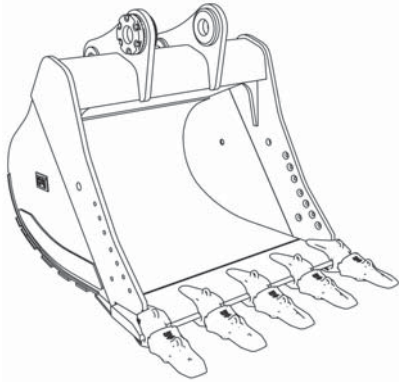

For digging in low impact, lower abrasion materials such as dirt, loam, and mixed compositions of dirt and fine gravel. Example: Digging conditions in which General Duty tip life exceeds 800 hours.

Typically larger General Duty buckets are the most popular sizes, and are used by site developers to mass excavate in low abrasion applications.

- Lighter structures decrease load time and increase the weight that can be lifted.
- Standard size adapters and tips.
- Sidebars are pre-drilled for optional sidecutters and sidebar protectors.

Heavy Duty

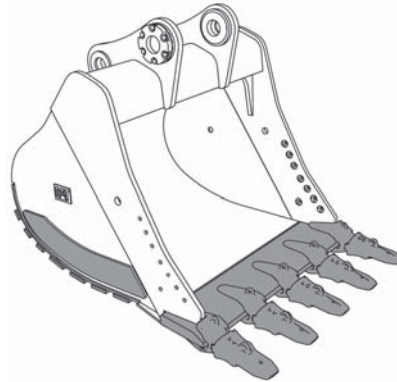

The most popular excavator bucket style. A good “center line” choice, or starting point, when application conditions are not well known.

For a wide range of impact and abrasion conditions including mixed dirt, clay and rock. Example: Digging conditions where Penetration Plus tip life ranges from 400 to 800 hours.

Heavy Duty Buckets are recommended for trenching in utilities work, and for the general contractor working in a variety of different situations.

- Thicker bottom and side wear plates than General Duty buckets for more durability.
- Adapters and tips are up-sized for enhanced performance and durability.
- Sidebars are pre-drilled for optional sidecutters and sidebar protectors.

Severe Duty

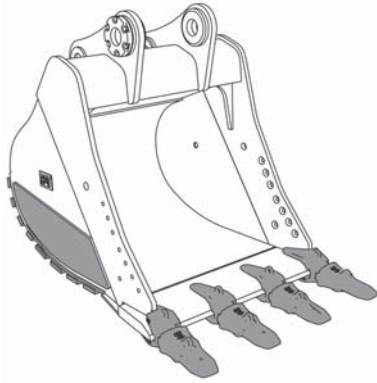

For higher abrasion conditions such as well shot granite and caliche. Example: Digging conditions where tip life ranges from 200 to 400 hours with Penetration Plus tips.

- Bottom wear plates are about 50% thicker than Heavy Duty buckets.
- Side wear plates are about 40% larger than Heavy Duty buckets for added protection against abrasive and gouging wear.
- Heavy Duty and Severe Duty buckets use same size adapters.
- Adapters are sized to accommodate higher abrasion conditions.
- Tips are up-sized (over the General Duty bucket) for enhanced performance and durability.
- Sidebars are pre-drilled for optional sidecutters and sidebar protectors.

Extreme Duty

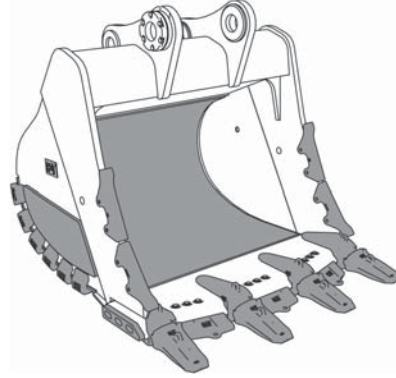

For very high abrasion conditions including high quartzite granite. Example: Digging conditions where tip life is less than or equal to 200 hours with Extra Duty tips.

- Corner (or heel) shrouds, Base Edge End Protectors (BEEPs), base edge segments, liners, and Mechanically Attached Wear Plates (MAWPs) protect the bucket from wear.
- Side wear plates are larger.
- Sidebar protection has been added for protection against abrasion and gouging wear.
- Adapters are sized to accommodate higher abrasion conditions.
- Tips are up-sized (over the General Duty bucket) for enhanced performance and durability.

Special Purpose Buckets

Caterpillar offers a range of special purpose buckets, variants of the durabilities listed above, to meet particular application needs.

Ditch Cleaning



These buckets are designed for cleaning ditches, sloping, grading and other finish work. Their shallow depth and compact size make working in confined areas easier. Drainage holes allow liquid to empty so material dumps more easily.

Ditch Cleaning Tilt

Tilt Buckets feature a full 45° of tilt in each direction, powered by two double-acting cylinders. Ditch Cleaning and Tilt Buckets are available for 311-336 excavators.

Center-Lock™ Pin Grabber Performance

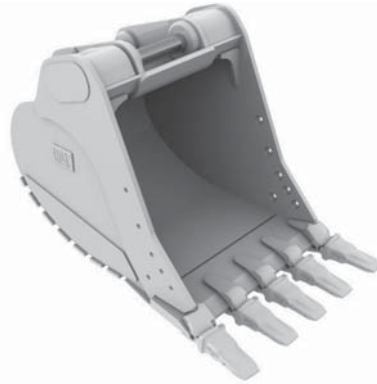

This bucket is designed with a patented recessed pin to provide maximum digging performance while keeping the versatility and convenience of a coupler. Tip radius is reduced and allows up to 10% improvement in breakout force when compared to a conventional pin-on Bucket and Coupler combination.

Center-Lock Performance Buckets are available for 315-345 excavators, in General Duty, Heavy Duty and Severe Duty durabilities.

Power

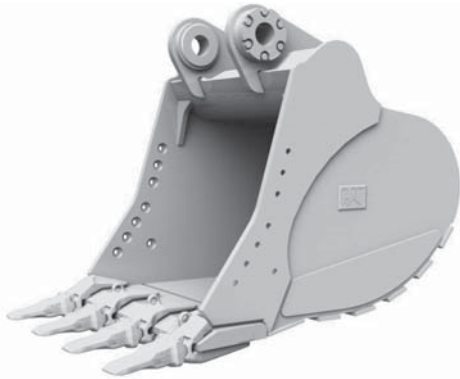

Power Buckets are for use in abrasive applications where breakout force and cycle times are critical — and for use in materials such as tightly compacted mixed dirt and rock. (Not recommended for clay.) Breakout force is maximized due to decreased tip radius and increased pin spread. Machine cycle times in most material is improved over a standard bucket in a similar application. Heavy Duty Power Buckets are available for 320-336 excavators.

Wide Tip



Wide Tip Buckets are intended to perform best in low-impact materials such as dirt and loam where leaving a smoother floor and minimal spillage is necessary. The bucket is engineered to be used exclusively with Cat Wide Tips. Corner adapters face straight forward to create a smooth edge. General Purpose Wide Tip Buckets are available in widths from 24" to 78" for 311-345 excavators.

High Capacity



High Capacity Buckets are designed and built for use in high production truck loading applications. With proper application and set up, these buckets will move more material in a minimal amount of passes — maximizing production. High Capacity Buckets are available for 349-390 excavators, in General Duty durability.

BUCKET SALES SUPPORT

The latest sales literature for HEX Buckets worldwide can be found in Work Tool Central at <https://dealer.cat.com/products/wtc>.

- HEX Bucket Specalog (NACD) — GEHQ0201
- 374D Buckets Product Bulletin — GEJQ0231

BUCKET PAYLOAD

An excavator's bucket payload (actual amount of material in the bucket on each digging cycle) is dependent on bucket size, shape, curl force, and certain soil characteristics, i.e., the fill factor for that soil. Fill factors for several types of material are listed below.

$$\text{Average Bucket Payload} = (\text{Heaped Bucket Capacity}) \times (\text{Bucket Fill Factor})$$

Material	Fill Factor Range (Percent of heaped bucket capacity)
Moist Loam or Sandy Clay	A — 100-110%
Sand and Gravel	B — 95-110%
Hard, Tough Clay	C — 80-90%
Rock — Well Blasted	60-75%
Rock — Poorly Blasted	40-50%

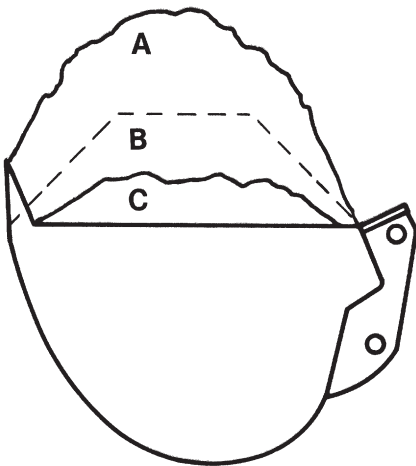

Working Weights — Bucket & Payload

The following tables give maximum “bucket plus payload” weights to assist in selecting the correct bucket for a specific application. These weights are based on actual job conditions. In better than average conditions the excavator may be able to achieve rated lift capacities listed in this section.

NOTE: Bucket sizes are suitable for a maximum material density of 1800 kg/m³ (3035 lb/yd³). Payloads shown are calculated at 1500 kg/m³ (2530 lb/yd³).

Model	Boom	Stick Length		Working Weights† Buckets & Payload	
		m	ft	kg	lb
300.9D	Swing	0.89	2'11"	—	—
301.4C/ 301.7D/ 301.7D CR	Swing	0.89	2'11"	234	516
		1.09	3'6"	210	463
302.2D/ 302.4D/ 302.7D CR	Swing	1.05	3'5"	—	—
		1.40	4'4"	—	—
303E CR	Swing	To Be Determined			
303.5E CR	Swing	1.26	4'2"	274	604
		1.56	5'1"	225	496
304E CR	Swing	1.32	4'4"	274	604
		1.62	5'4"	225	496
305E2 CR	Swing	1.38	4'6"	513	1130
		1.78	5'10"	464	1020
305.5E2 CR	Swing	1.43	4'8"	513	1130
		1.83	6'0"	464	1020
308E2 CR SB	Swing	1.67	5'6"	1153	2430
		2.21	7'3"	899	1980
311D LRR	Reach	2.25	7'5"	1537	3390
		2.60	8'6"	1295	2850
		2.80	9'2"	1295	2850
312D	Reach	2.10	6'11"	1720	3790
		2.50	8'2"	1592	3510
		2.80	9'2"	1402	3090
		2.80	9'2"	1402	3090
		3.00	9'10"	1402	3090
312D L	Reach	2.10	6'11"	1764	3890
		2.50	8'2"	1633	3600
		2.80	9'2"	1439	3170
		3.00	9'10"	1439	3170
313C SR	Parallel Offset	2.13	7'0"	2060	4540
		2.13	7'0"	1537	3390
313C CR	Reach	2.50	8'2"	1240	2730
		3.00	9'10"	1075	2370

†Working weights may vary depending on machine configuration and geographic location. Contact your Cat dealer for specific information.

Model	Boom	Stick Length		Working Weights† Buckets & Payload	
		m	ft	kg	lb
314D CR		2.50	8'2"	1538	3390
		2.80	9'2"	1351	2980
		3.00	9'10"	1351	2980
314D LCR	Reach	2.50	8'2"	1560	3440
		2.80	9'2"	1372	3020
		3.00	9'10"	1372	3020
315D L	Reach	1.85	6'1"	2141	4720
		2.25	7'5"	2018	4450
		2.60	8'6"	1862	4110
		2.90	9'6"	1719	3790
		3.10	10'2"	1719	3790
319D L		1.80	5'11"	3158	6963
		2.25	7'5"	2883	6357
		2.70	8'10"	2649	5841
		3.20	10'6"	2309	5091
319D LN		1.80	5'11"	2759	6084
		2.25	7'5"	2522	5561
		2.70	8'10"	2317	5109
		3.20	10'6"	2010	4432
320D2	Reach	1.90	6'3"	2450	5390
		2.50	8'2"	2560	5632
		2.90	9'7"	2460	5412
		3.90	12'10"	2020	4444
	Mass	2.40	7'10"	2730	6006
320D2 L	Reach	1.90	6'3"	2850	6270
		2.50	8'2"	2900	6380
		2.90	9'7"	2750	6050
		3.90	12'10"	2320	5104
	Mass	2.40	7'10"	3170	6974
321D LCR	Reach	2.90	9'6"	2830	6250

†Working weights may vary depending on machine configuration and geographic location. Contact your Cat dealer for specific information.

Model	Boom	Stick Length		Working Weights† Buckets & Payload	
		m	ft	kg	lb
323E L	Reach	1.90	6'3"	3606	7951
		2.50	8'2"	3344	7374
		2.90	9'6"	3096	6827
	Mass	2.40	7'10"	4152	9155
	VA	1.90	6'3"	3106	6849
		2.50	8'2"	2910	6417
2.90		9'6"	2695	5942	
323E LN	Reach	1.90	6'3"	3005	6626
		2.50	8'2"	2815	6207
		2.90	9'6"	2745	6053
	VA	1.90	6'3"	2531	5581
		2.50	8'2"	2406	5305
		2.90	9'6"	2218	4891
323D2 L China	Reach	2.9 HD	9'6"	23 100/ 25 510	50,926/ 56,240
		2.5 HD	8'2"	23 070/ 25 490	50,860/ 56,195
	Mass	M2.4	7'9"	23 170/ 25 600	51,081/ 56,438
324E Belgium	Reach	2.50	8'2"	2910	6420
		2.95	9'8"	2690	5930
		3.60	11'10"	2320	5120
	Mass	2.00	6'7"	3390	7480
		2.50	8'2"	3030	6680
324E L Belgium	Reach	2.50	8'2"	3410	7520
		2.95	9'8"	3160	6970
		3.60	11'10"	2760	6090
	Mass	2.00	6'7"	4010	8840
		2.50	8'2"	3630	8010
324E LN Belgium	Reach	2.00	6'7"	3750	8270
		2.50	8'2"	3390	7470
	Mass	2.00	6'7"	3240	7140
		2.50	8'2"	3150	6940
		2.95	9'8"	2910	6420
VA	3.60	11'10"	2710	5970	
	2.00	6'7"	3850	8490	
	2.50	8'2"	3430	7560	
VA	2.00	6'7"	3260	7190	
	2.50	8'2"	2950	6500	

†Working weights may vary depending on machine configuration and geographic location. Contact your Cat dealer for specific information.

NOTE: Maximum load (payload plus bucket) without quick coupler.

Model	Boom	Stick Length		Working Weights† Buckets & Payload	
		m	ft	kg	lb
329E L Belgium	Reach	2.00	6'7"	3450	7610
		2.65	8'8"	3140	6930
		3.20	10'6"	2840	6270
	Mass	2.00	6'7"	4090	9020
		2.50	8'2"	3650	8050
329E L Belgium	Reach	2.00	6'7"	3430	7560
		2.50	8'2"	3130	6900
		3.20	10'6"	2820	6220
	Mass	2.00	6'7"	4060	8950
		2.65	8'8"	3680	8120
		3.20	10'6"	3360	7410
329E L	Reach	2.00	6'7"	4810	10,610
		2.50	8'2"	4290	9460
	VA	2.00	6'7"	4090	9020
		2.50	8'2"	3740	8250
		3.20	10'6"	3360	7410
329E L	Reach	2.00	6'7"	3450	7610
		2.65	8'8"	3140	6930
		3.20	10'6"	2840	6270
	Mass	2.00	6'7"	4090	9020
		2.50	8'2"	3650	8050
329E LN Belgium	Reach	2.00	6'7"	3430	7560
		2.50	8'2"	3130	6900
		3.20	10'6"	2820	6220
	Mass	2.00	6'7"	3530	7790
		2.65	8'8"	3210	7080
		3.20	10'6"	2910	6420
329E LN Belgium	Reach	2.00	6'7"	4180	9220
		2.50	8'2"	3730	8230
	VA	2.00	6'7"	3490	7690
		2.50	8'2"	3190	7030
		3.20	10'6"	2870	6330

†Working weights may vary depending on machine configuration and geographic location. Contact your Cat dealer for specific information.

Model	Boom	Stick Length		Working Weights† Buckets & Payload	
		m	ft	kg	lb
336D Belgium	Reach	2.15	7'1"	4500	9920
		2.80	9'2"	4000	8820
		3.30	10'10"	3690	8140
		3.90	12'10"	3250	7170
	Mass	2.15	7'1"	5030	11,090
		2.55	8'4"	4440	9790
336D L Belgium	Reach	2.15	7'1"	4700	10,360
		2.80	9'2"	4160	9170
		3.30	10'10"	3830	8440
		3.90	12'10"	3240	7540
	Mass	2.15	7'1"	5210	11,490
		2.55	8'4"	4640	10,230
336D L	Reach	2.15	7'1"	4700	10,360
		2.80	9'2"	4160	9170
		3.30	10'10"	3830	8440
		3.90	12'10"	3240	7540
	Mass	2.15	7'1"	5210	11,490
		2.55	8'4"	4640	10,230
336D LN Belgium	Reach	2.15	7'1"	4150	9150
		2.80	9'2"	3700	8160
		3.30	10'10"	3410	7520
		3.90	12'10"	3000	6610
	Mass	2.15	7'1"	4660	10,270
		2.55	8'4"	4100	9040
		3.50	11'6"	3530	7780
345B Series II - ES	Reach	2.90	9'6"	8417	18,560
		3.40	11'2"	7886	17,390
	Mass	2.50	8'2"	9636	21,240
		3.00	9'10"	8986	19,810
345D L - FIX	Long Reach	3.90	12'10"	4250	9370
		4.30	14'1"	3940	8690
	Reach	2.90	9'6"	5550	12,240
		3.35	11'0"	5180	11,420
		3.90	12'10"	4850	10,690
	Mass	2.50	8'2"	6260	13,800
3.00		9'10"	5790	12,760	
345D L - VG	Long Reach	3.90	12'10"	4540	10,010
		4.30	14'1"	4880	10,760
	Reach	2.90	9'6"	6830	15,060
		3.35	11'0"	6930	15,280
		3.90	12'10"	6000	13,230
	Mass	2.50	8'2"	7550	16,640
3.00		9'10"	6790	14,970	

†Working weights may vary depending on machine configuration and geographic location. Contact your Cat dealer for specific information.

Model	Boom	Stick Length		Working Weights† Buckets & Payload	
		m	ft	kg	lb
365C L Belgium	Reach	2.84	9'3"	9965	21,970
		3.60	11'8"	9026	19,900
		4.15	13'6"	8262	18,220
		4.67	15'3"	7544	16,640
	Mass 6.6 m (21'9")	2.57	8'4"	12 955	28,570
		3.00	9'8"	11 956	26,360
385C Belgium	Mass 7 m (23'0")	2.57	8'4"	11 798	26,020
		3.00	9'8"	10 907	24,050
	Reach	4.40	14'4"	6851	15,110
		5.50	18'0"	5917	13,050
	General Purpose	3.40	11'1"	10 359	22,840
		3.70	12'1"	10 018	22,090
4.40		14'4"	9725	21,440	
5.50		18'0"	8412	18,550	
Mass	2.92	9'6"	14 209	31,330	
	3.40	11'2"	13 257	29,230	
385C L Belgium	Reach	4.40	14'4"	7169	15,810
		5.50	18'0"	6209	13,690
	General Purpose	3.40	11'2"	10 755	23,720
		3.70	12'1"	10 411	22,960
		4.40	14'4"	10 089	22,250
	Mass	5.50	18'0"	8742	19,280
2.92		9'6"	14 309	31,550	
		3.40	11'2"	13 380	29,500

†Working weights may vary depending on machine configuration and geographic location. Contact your Cat dealer for specific information.

Hydraulic Excavators

Long Reach

- Introduction
- Range Dimensions
- Bucket Information

INTRODUCTION

Long reach excavators are designed purposely for light duty digging that requires reach capability well above that of normal digging machines. To be able to have high enough digging forces together with an acceptable size bucket, the long reach excavators have a smaller digging envelope than the ditch cleaning machines. Long reach excavators are ideally suited for deep digging in gravel or sand pits then feeding directly into a hopper.

Caterpillar's long reach hydraulic excavators use purpose-built booms and sticks designed by Caterpillar for maximum performance and durability in light duty applications.

Long Reach Excavation Fronts include: boom, stick, linkage cylinders (boom, stick, and bucket), hydraulic lines, additional counterweight for stability over the side and heavy duty wide undercarriage. Dimensions include light excavation bucket.

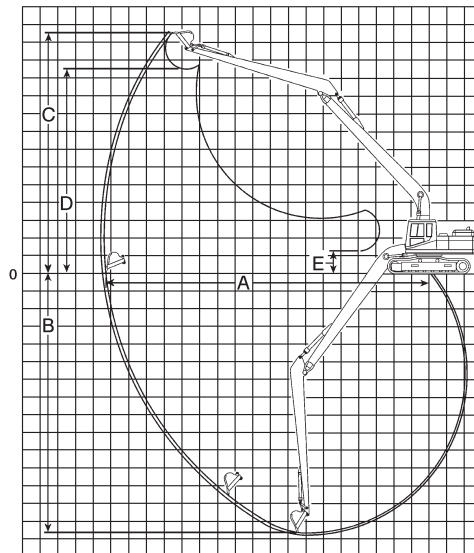

Long Reach, Range Dimensions

320D2 L

	m	ft
A Maximum Reach at Ground Level	15.72	51'7"
B Maximum Digging Depth	11.87	38'11"
C Maximum Cutting Height	13.30	43'8"
D Maximum Dumping Height	11.02	36'2"
E Minimum Loading Height	1.97	6'6"

Long Reach, Bucket Information

Model	Bucket Type	Bucket Width		SAE Heaped Cap.		Bucket Weight		No. of Teeth	Bucket Curl Force		Stick Crowd Force	
		mm	ft	L	yd ³	kg	lb		kN	lb	kN	lb
320D2 L (ISO)	Excavation	810	2'8"	450	0.6	340	750	5	61	13,691	49	10,948
320D2 L (SAE)	Excavation	810	2'8"	450	0.6	340	750	5	54	12,185	48	10,813

- Shipping Dimensions
- Major Component Weights

Hydraulic Excavators

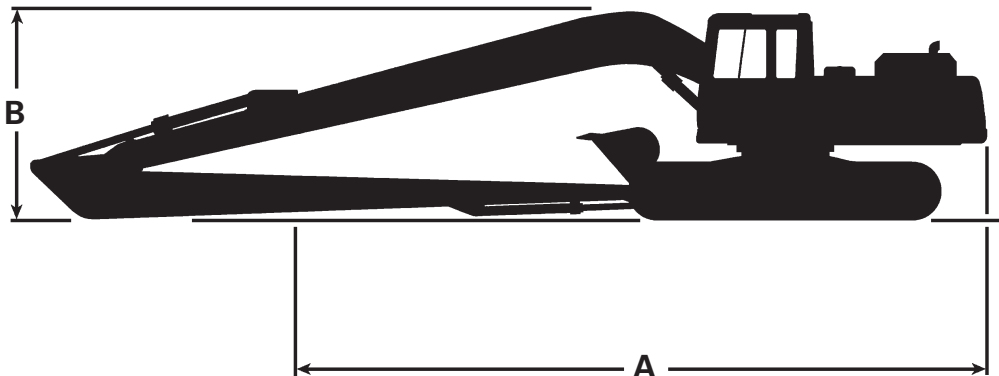

Long Reach, Shipping Dimensions

320D2 L

	m	ft
A Overall Length (Front Folded)	12.68	41'7"
B Overall Height	3.05	10'0"
C Overall Width	3.17	10'5"

Long Reach, Component Weights

320D2 L

	kg	lb
Total Component Weight – Includes additional over standard	4810	10,600
Long Reach Boom	2350	5180
Long Reach Stick	1020	2250

Hydraulic Excavators

Long Reach Excavation

- Introduction
- Range Dimensions
- Bucket Information

INTRODUCTION

Long Reach Excavation machines are designed specifically for jobs requiring longer reach than standard excavators, combined with digging capabilities.

The boom and the stick are purposely designed to perform digging operations with an acceptable bucket size.

The performances of the machine are attained through the use of bigger boom cylinders, heavy-duty wide undercarriage and significant additional counterweight. A heavy-duty upper-frame is also used in order to guarantee durability and resistance to the extra stresses generated by that demanding application.

Long Reach Excavation machines are ideally suited for deep or long distance digging in sand or gravel pits, slope forming, cleaning of settling banks, river conservation and other work formerly reserved for draglines.

These excavators can of course feed directly into a hopper or load a truck that would stand by their side.

The boom and the stick are designed following Caterpillar's standards, in order to provide the maximum performance and durability in digging applications.

Long Reach Excavation Fronts include: boom, stick, linkage (boom, stick, and bucket cylinders), hydraulic lines and additional counterweight.

Dimensions include the bucket.

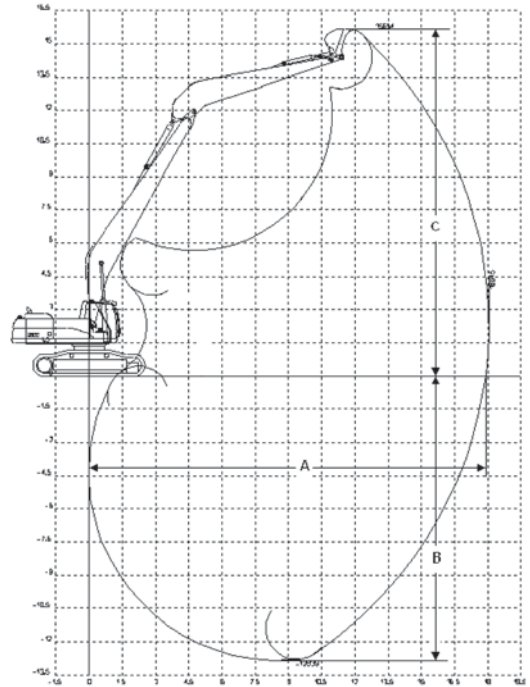

Long Reach Excavation, Range Dimensions

330D HDHW LRE Long

385C LRE Long

	Heavy Duty High Wide (HDHW)	Long Variable Gauge (LVG)
Undercarriage		
Boom Length	10 660 mm	12 500 mm
Stick Length	7100 mm	9500 mm
A Maximum Reach	18 045 mm	21 310 mm
B Maximum Digging Depth	12 890 mm	15 825 mm
C Maximum Cutting Height	15 580 mm	16 015 mm

Long Reach Excavation
 ● Shipping Dimensions
 ● Major Component Dimensions and Weights

**Hydraulic
Excavators**

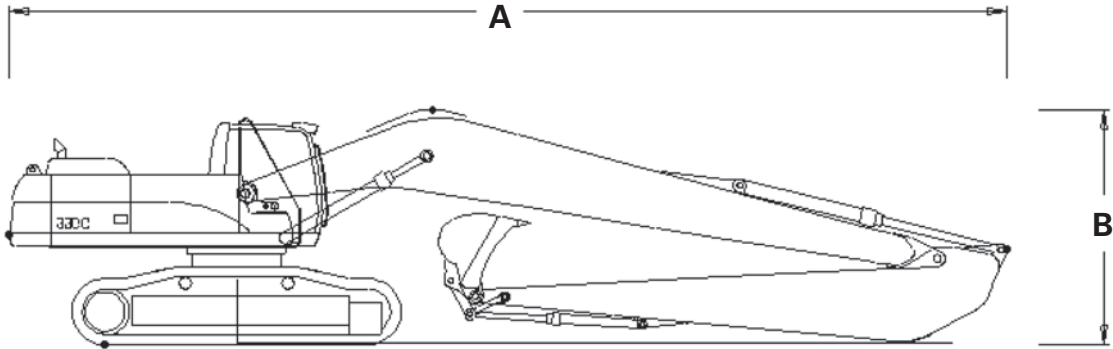

**Long Reach Excavation,
Shipping Dimensions and Weight**

**330D HDHW
LRE Long**

**385C L
LRE Long**

	Heavy Duty High Wide (HDHW)	Long Variable Gauge (LVG)
Undercarriage		
Shoes	700 mm	750 mm
Boom Length	10 660 mm	12 500 mm
Stick Length	7 100 mm	9 500 mm
A Overall Length (Front Folded)	15 310 mm	18 780 mm
B Overall Height (Front Folded)	3 595 mm	4 280 mm
Overall Width	3 620 mm	3 500 mm
Operating Weight	36 680 kg	88 490 kg

Long Reach Excavation Lift Capacities at Ground Level

Lift Capacities at Ground Level		3 m		4.5 m		6 m		7.5 m		9 m	
		Front Load	Side Load	Front Load	Side Load	Front Load	Side Load	Front Load	Side Load	Front Load	Side Load
330D HDHW LRE Long	kg	2250*	2250*	4850*	4850*	9940*	8610	7490*	6340	5940*	4880
385C L LRE Long	kg	5480*	5480*	9290*	9290*	16 720*	16 720*	18 040*	17 340	14 370*	13 490

Lift Capacities at Ground Level		10.5 m		12 m		13.5 m		15 m		16.5 m	
		Front Load	Side Load	Front Load	Side Load	Front Load	Side Load	Front Load	Side Load	Front Load	Side Load
330D HDHW LRE Long	kg	4890*	3860	4040*	3080	3570*	2480	3120*	2000	2680*	1610
385C L LRE Long	kg	11 840*	10 800	10 000*	8780	8800*	7210	7500*	5950	6800*	4910

Lift Capacities at Ground Level		18 m		19.5 m		Max. Reach		Maximum Reach Radius
		Front Load	Side Load	Front Load	Side Load	Front Load	Side Load	
330D HDHW LRE Long	kg	—	—	—	—	1940*	1410	17.62 m
385C L LRE Long	kg	5840*	4050	4340*	3320	3250*	2900	20.77 m

*Load limited by hydraulic capacity rather than tipping.

- Super Long Reach
- Introduction
 - Range Dimensions
 - Bucket Information

Hydraulic Excavators

INTRODUCTION

Super long reach excavators are designed specifically for those jobs requiring maximum reach well beyond the range of normal excavators. Those machines are designed to drag a small bucket at about 90 degrees over the side of the tracks towards the excavator; they are not suited for digging work. Caterpillar offers the Long Reach excavators for light digging applications with a much larger digging envelope than normal excavators. Super long reach excavators are suited for ditch cleaning, slope finishing, river conservation and other work formerly reserved to draglines.

Caterpillar's super long reach hydraulic excavators use purpose-built booms and sticks designed by Caterpillar for maximum performance and durability in dragging applications.

Super long reach fronts include: boom, stick, linkage cylinders (boom, stick, and bucket), hydraulic lines and additional counterweight for stability while working over the side. Dimensions include bucket.

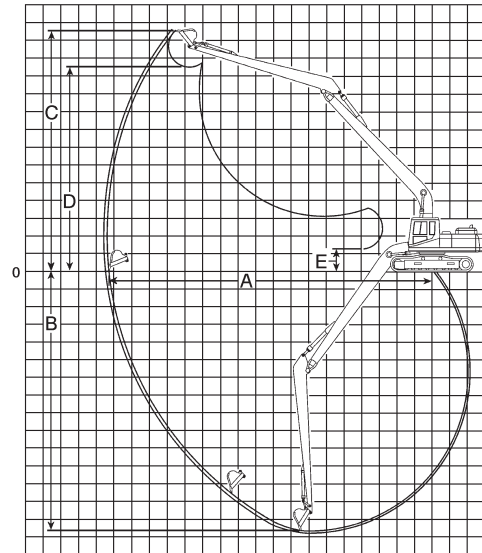

Super Long Reach, Range Dimensions	312C L*		315C L, 317B L*		320D2 L	
	m	ft	m	ft	m	ft
A Maximum Reach at Ground Level	12.54	41'2"	13.00	42'8"	15.72	51'7"
B Maximum Digging Depth	9.80	32'2"	10.10	33'2"	11.87	38'11"
C Maximum Cutting Height	10.96	35'11"	11.64	38'2"	13.30	43'8"
D Maximum Dumping Height	9.01	29'9"	9.58	31'5"	11.02	36'2"
E Minimum Loading Height	2.15	7'1"	2.55	8'4"	1.97	6'6"

	326D2 L		330D2 L	
	m	ft	m	ft
A Maximum Reach at Ground Level	18.30	60'0"	18.29	60'0"
B Maximum Digging Depth	14.59	47'10"	14.62	48'0"
C Maximum Cutting Height	14.19	46'7"	13.58	44'7"
D Maximum Dumping Height	12.13	39'10"	11.55	37'11"
E Minimum Loading Height	1.48	4'10"	1.30	4'3"

Super Long Reach, Bucket Information

Model	Bucket Type	Bucket Width		SAE Heaped Cap.		Bucket Weight		No. of Teeth	Bucket Curl Force		Stick Crowd Force	
		mm	ft	L	yd ³	kg	lb		kN	lb	kN	lb
312C*	Ditch Cleaning	920	3'0"	480	0.63	230	510	4	44	9900	37	8300
320D2 L	Ditch Cleaning	1140	3'9"	450	0.60	290	640	0	54	12,185	48	10,813
326D2 L	Ditch Cleaning	1140	3'9"	600	0.78	290	640	0	61	13,600	45	10,152
330D2 L*	Ditch Cleaning	1140	3'9"	600	0.78	290	640	5	63	14,223	46	10,352

*Custom product.

Hydraulic Excavators

Super Long Reach

- Shipping Dimensions
- Major Component Weights

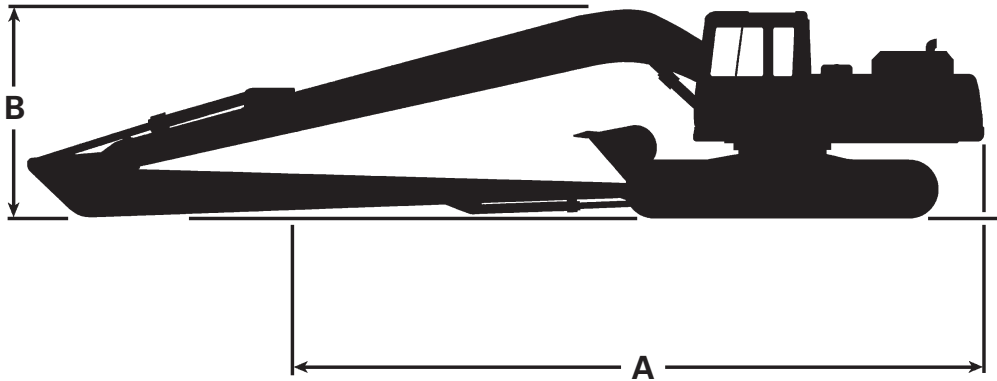

Super Long Reach, Shipping Dimensions	312C*		315D L*		320D2 L	
	m	ft	m	ft	m	ft
A Overall Length (Front Folded)	10.22	33'6"	11.23	36'10"	12.68	41'7"
B Overall Height	2.80	9'2"	2.92	9'7"	3.05	10'0"
C Overall Width	2.76	9'1"	2.75	9'0"	3.17	10'5"

	326D2 L		330D2 L	
	m	ft	m	ft
A Overall Length (Front Folded)	14.34	47'1"	14.42	47'2"
B Overall Height	3.15	10'4"	3.23	10'7"
C Overall Width	3.38	11'1"	3.39	11'1"

Super Long Reach, Component Weights	312C*		315D L*		320D2 L	
	kg	lb	kg	lb	kg	lb
Total Component Weight Includes additional over standard	2450	5400	3050	6725	4840	10,670
Long Reach Boom	1140	2510	1210	2670	2350	5180
Long Reach Stick	640	1410	780	1720	1020	2250

	326D2 L		330D2 L	
	kg	lb	kg	lb
Total Component Weight Includes additional over standard	6950	15,320	6500	14,330
Long Reach Boom	3130	6900	3100	6830
Long Reach Stick	1560	3440	1610	3549

*Custom product.

Short Reach
 ● Range Dimensions
 ● Front Attachment Information

Hydraulic
 Excavators

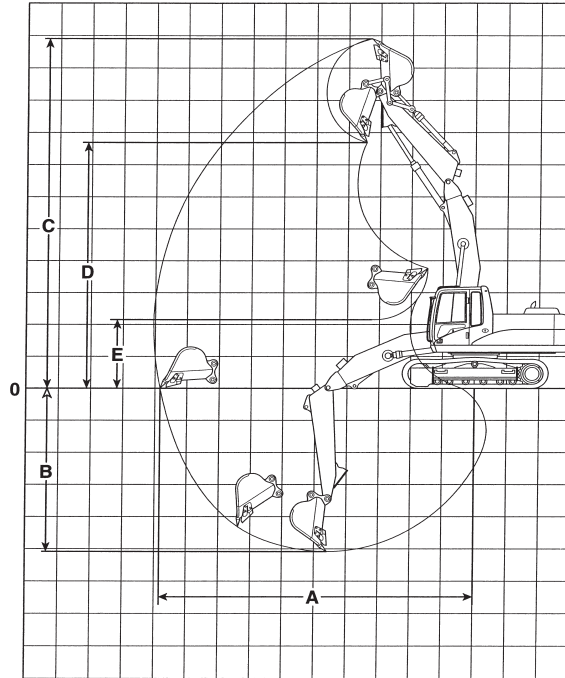

**Short Reach,
 Range Dimensions**

314C CR*

336D L*

	314C CR*		336D L*	
	m	ft	m	ft
A Maximum Reach at Ground Level	6.54	21'5"	8.88	29'2"
B Maximum Digging Depth	8.15	26'9"	9.95	32'8"
C Maximum Cutting Height	2.22	7'3"	3.76	12'4"
D Maximum Dumping Height	5.56	18'3"	6.64	21'9"
E Minimum Loading Height	1.91	6'3"	1.80	5'11"

Short Reach, Front Attachment Information

Model	Boom Length		Stick Length		Heaped Capacity	
	mm	ft	mm	ft	L	yd ³
314C CR*	3200	10'6"	2400	7'10"	500	0.7
336D L*	4350	14'3"	3200	10'6"	1400	1.83

*Custom product.

Hydraulic Excavators

Short Reach

- Shipping Dimensions
- Major Component Weights

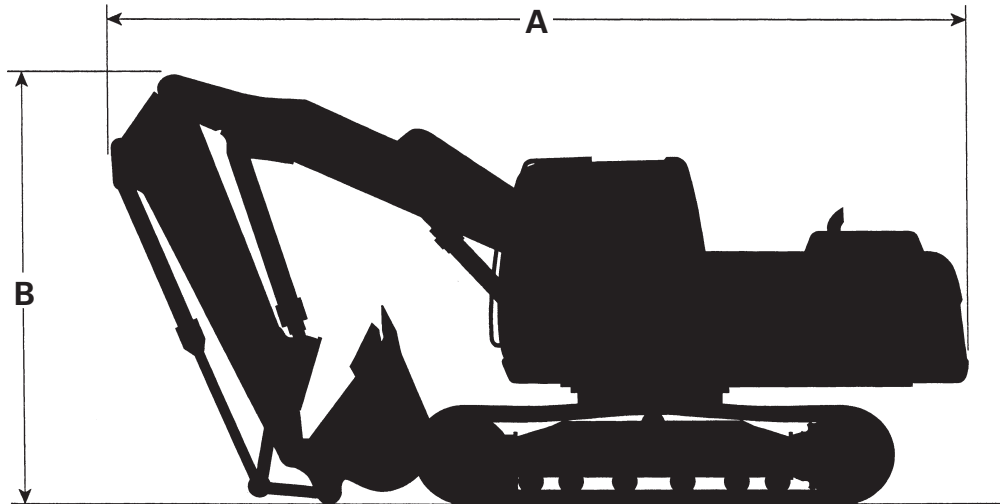

Short Reach, Shipping Dimensions	314C CR*		336D L*	
	m	ft	m	ft
A Overall Length (Front Folded)	5.35	17'7"	8.27	27'2"
B Overall Height	2.73	8'11"	3.87	12'8"
C Overall Width	2.49	8'2"	3.35	11'0"

Short Reach, Component Weights	314C CR*		336D L*	
	kg	lb	kg	lb
Total Component Weight Includes additional over standard	3350	7390	6000	13,230
Short Reach Boom	1140	2510	2170	4780
Short Reach Stick	600	1320	1300	2870

*Custom product.

MACHINE SELECTION: TRACKS VERSUS WHEELS

Features:

Tracks

- Flotation
- Traction
- Maneuverability
- Severe underfoot
- Faster machine repositioning

Wheels

- Mobility and speed
- No pavement damage
- Better stability with outriggers or dozers
- Leveling machine with outriggers
- Dozing capability

307–385

Unless the application calls for a lot of travel to, from, and around the job sites, a track-type excavator could be the better choice. Track-type excavators provide good traction and flotation in almost all kinds of underfoot conditions. Consistently good drawbar power provides excellent maneuverability. The tracked undercarriage also provides good overall stability. If the job calls for frequent machine repositioning, a track-type excavator will provide better operating efficiency — where raising and lowering outriggers would take extra time.

Wheels (M313D–M322D)

Looking for a highly versatile machine? A machine that can do more than mass excavation and trenching. Consider a Wheel Excavator.

A Wheel Excavator combines traditional excavator features such as 360° swing, long reach, deep digging depth, high loading height, high digging forces and high lift capacities, with the mobility of a wheeled undercarriage. The rubber tires allow the excavator to travel paved

roads, work in shopping malls, squares, parking lots and other paved areas without damaging the pavement. It's mobility allows fast independent travel between job sites as well as on the job site giving you more job planning flexibility. The Wheel Excavator is the ideal tool for truck loading in tight quarters, undercutting concrete or asphalt, patching, shoulder work, curb and gutter repair, landscaping, spreading top soil, fine grading, laying pipe, placing manholes or ditch cleaning.

A Wheel Excavator is also an ideal machine in material handling. It can load or unload trucks and carry loads around the job site. Stabilizers and a dozer blade can be pinned to the undercarriage increasing the machines stability during lifting.

Equip the Wheel Excavator with dedicated special attachments such as cab riser, material handling stick and boom. Add the additional hydraulic circuit option and your ready for a complete range of special tools. Ditch cleaning bucket, clamshell, grapples, hammers to name a few.

Cat Wheel Excavators offer a load independent, load-sensing, flow distribution hydraulic system that gives the operator absolute precision and control no matter what the application.

Machine weight is the key to selecting a Wheel Excavator. Following are some additional factors that need to be considered.

Choose the proper boom and stick for your reach, digging depth and lifting requirements. Stability can be greatly enhanced by adding outriggers and/or a dozer blade. Additional hydraulic circuits can be added depending on your application and stick end attachments.

Acceptable Bucket/Stick Combinations

The following charts identify the acceptable bucket and stick combinations for Cat Wheel Excavators and are based on stability. Minimum stability occurs with the linkage oriented over the side and positioned as shown in the visual. Dozer and/or stabilizers (if equipped) are raised and the bucket contains a full load. The longest stick is shown that has acceptable stability for each bucket. That stability is 1.1 moment ratio or better. Once this stability factor is established, all shorter sticks are then acceptable with the listed bucket.

EXCAVATOR SHOE SELECTION

Undercarriage life can be extended by equipping the machine properly for the application.

Many excavators work on pavement or flat, soft ground and experience few undercarriage problems. But if those same machines (usually equipped with wide track pads) were placed in severe underfoot conditions, undercarriage destruction could occur very rapidly.

The rule, used for other track-type machines — *“Whenever possible use the narrowest shoes available”* — is even more valid for excavators.

The best general purpose track shoe is the triple grouser. It has a good section modulus and offers the best compromise between traction and minimum disturbance to paved surface.

The double grouser shoe has a better section modulus and is more aggressive than the triple grouser section. Single grouser shoes are offered for maximum traction. Some users like single grousers for added mobility in hilly terrain.

The following table lists ground pressures for various width shoes (reach boom, medium stick and bucket):

Model	Shoe Type	Shoe Width		Pressure	
		mm	in	kPa	psi
300.9D	Rubber Belt	180	7	24.10	3.50
301.4C	Rubber Belt	230	9	—	—
301.7D	Rubber Belt	230	9	29.42	4.27
301.7D CR	Rubber Belt	230	9	27.50	3.98
302.2D	Rubber Belt	250	10	28.44	4.13
302.4D	Rubber Belt	250	10	28.44	4.13
302.7D CR	Rubber Belt	300	12	—	—
303E CR	Steel Double Grouser	300	12	—	—
	Rubber Belt	300	12	30.40	4.40
303.5E CR	Steel Double Grouser	300	12	—	—
	Rubber Belt	300	12	30.40	4.40
304E CR	Steel Double Grouser	350	14	—	—
	Rubber Belt	350	14	29.60	4.30
305E2 CR	Steel Triple Grouser	400	16	—	—
	Rubber Belt	400	16	28.50	4.10
305.5E2 CR	Steel Triple Grouser	400	16	—	—
	Rubber Belt	400	16	30.20	4.40
308E2 CR SB	Steel Triple Grouser	450	18	36.80	5.30
	Rubber Belt	450	18	36.80	5.30
	Steel Triple Grouser	600	24	27.00	3.90

Model	Shoe Type	Shoe Width		Pressure	
		mm	in	kPa	psi
311F L RR	Triple	500	20	40.1	5.80
	Triple	600	24	34.0	4.90
	Triple	700	28	29.8	4.30
	Triple	770	30	27.3	4.00
312D2	Triple	500	20	41.7	6.05
	Triple	600	24	35.5	5.15
	Triple	700	28	31.0	4.50
	Triple	770	30	28.4	4.12
312D2 L	Triple	500	20	39.4	5.71
	Triple	600	24	33.3	4.83
	Triple	700	28	29.2	4.24
	Triple	770	30	26.7	3.87
313D2	Triple	500	20	43.4	6.29
312D2 GC	Triple	500	20	40.4	5.86
312E	Triple	500	20	42.4	6.15
	Triple	600	24	36.1	5.24
	Triple	700	28	31.4	4.56
	Triple	770	30	28.8	4.18
312E L	Triple	500	20	40.2	5.83
	Triple	600	24	34.1	4.94
	Triple	700	28	29.8	4.32
	Triple	770	30	27.3	3.97
312F GC	Triple	500	20	40.4	5.90
	Triple	700	28	30.0	4.40
313D2 LGP	Single	960	38	23.7	3.44
313F L GC	Triple	500	20	39.7	5.80
	Triple	600	24	33.1	4.80
	Triple	700	28	29.4	4.30
314E CR	Triple	500	20	43.2	6.27
	Triple	600	24	36.5	5.32
	Triple	700	28	31.9	4.63
314E LCR	Triple	500	20	43.2	6.27
	Triple	600	24	36.5	5.29
	Triple	700	28	31.9	4.63
316E L	Triple	500	20	49.0	7.10
	Triple	600	24	42.0	6.09
	Triple	700	28	36.0	5.22

Model	Shoe Type	Shoe Width		Pressure	
		mm	in	kPa	psi
318D2 L	Triple	500	20	48.3	7.01
	Triple	600	24	40.8	5.92
	Triple	700	28	35.8	5.19
318E L	Triple	500	20	52.0	7.54
	Triple	600	24	43.0	6.24
	Triple	700	28	38.0	5.51
320D2	Triple	600	24	46.8	6.80
	Triple	700	28	40.8	5.90
	Triple	800	32	36.2	5.30
320D2 GC	Triple	600	24	47.5	6.90
	Triple	790	31	37.1	5.40
320D2 L	Triple	600	24	43.5	6.30
	Triple	700	28	38.0	5.50
	Triple	800	32	33.6	4.90
320E	Triple	600	24	47.9	6.95
	Triple	700	28	41.8	6.06
	Triple	790	31	37.5	5.44
320E L	Triple	600	24	44.9	6.51
	Triple	700	28	39.1	5.67
	Triple	790	31	35.1	5.09
320E RR	Triple	600	24	53.0	7.69
	Triple	700	28	46.1	6.68
	Triple	790	31	41.3	5.99
320E LRR	Triple	600	24	59.9	8.69
	Triple	700	28	52.1	7.55
	Triple	790	31	46.6	6.76
320F L	Triple	600	24	45.0	6.53
	Triple	700	28	39.3	5.70
	Triple	790	31	35.2	5.10
323E L	Triple	600	24	47.0	6.82
	Triple	700	28	40.9	5.93
	Triple	790	31	36.7	5.32
323E LN	Triple	500	20	68.9	9.99
323E SA	Triple	550	22	65.0	9.43
323F L	Single	600	24	47.2	6.85
	Triple	790	31	36.3	5.27

NOTE: Belgium sourced excavators have different ground pressures. See Technical Data Sheets.

Model	Shoe Type	Shoe Width		Pressure	
		mm	in	kPa	psi
325F L	Triple	600	24	40.9	5.90
	Triple	790	31	52.7	7.60
326D2 L	Triple	600	24	50.7	7.40
	Double	600	24	51.3	7.40
	Triple	700	28	43.9	6.40
	Triple	790	31	39.4	5.70
326F	Double	600	24	49.5	7.20
	Triple	700	28	43.2	6.30
	Triple	790	31	38.7	5.60
326F L	Triple	600	24	49.8	7.20
	Double	600	24	49.8	7.20
	Triple	700	28	43.2	6.30
	Triple	790	31	38.9	5.60
	Triple	900	35	34.7	5.00
330D2 L	Triple	600	24	54.8	7.90
	Triple HD	600	24	55.8	8.10
	Double	600	24	55.6	8.10
	Triple	700	28	47.5	6.90
	Triple	790	31	42.5	6.20
330F	Double	600	24	55.2	8.00
	Triple	700	28	47.9	6.90
	Triple	790	31	41.9	6.10
330F L	Triple	600	24	54.3	7.90
	Double	600	24	55.2	8.00
	Triple	700	28	47.1	6.80
	Triple	800	32	42.1	6.10
	Triple	900	35	37.9	5.50
335F L	Triple	600	24	64.9	9.40
	Triple	850	33	47.5	6.90

NOTE: Belgium sourced excavators have different ground pressures. See Technical Data Sheets.

Model	Shoe Type	Shoe Width		Pressure	
		mm	in	kPa	psi
336D2	Triple	600	24	71.5	10.37
	Triple	700	28	61.9	8.98
	Triple	800	32	55.1	8.00
336D2 L	Triple	600	24	66.1	9.59
	Triple	700	28	57.2	8.30
	Triple	800	32	51.0	7.40
336D2 – ES	Triple	600	24	71.0	10.30
336E L	Triple	600	24	67.1	9.70
	Triple	700	28	58.0	8.40
	Triple	800	32	51.7	7.50
	Triple	850	34	49.0	7.10
336E LN	Triple	600	24	66.5	9.60
	Triple	700	28	57.5	8.30
336E L H	Triple	600	24	66.5	9.60
	Triple	700	28	57.5	8.30
	Triple	800	32	51.3	7.40
	Triple	850	34	48.7	7.10
336E LN H	Triple	600	24	66.1	9.60
	Triple	700	28	57.3	8.30
336F L	Triple	600	24	67.8	9.80
	Triple	700	28	58.6	8.50
	Triple	800	32	52.2	7.60
	Triple	850	34	49.6	7.20

NOTE: Belgium sourced excavators have different ground pressures. See Technical Data Sheets.

Model	Shoe Type	Shoe Width		Pressure	
		mm	in	kPa	psi
349D2	Triple	750	30	66.3	9.63
	Double	750	30	66.3	9.63
349D2 L – FIX	Triple	600	24	76.8	11.14
	Triple	750	30	62.5	9.07
	Triple	900	35	53.0	7.67
	Double	600	24	77.0	11.16
349E	Double	600	24	87.0	12.60
	Triple	750	28	71.0	10.30
349E L – FIX	Double	600	24	83.0	12.00
	Triple	750	30	67.0	9.70
	Triple	900	35	57.0	8.30
349E L – VG	Double	600	24	88.0	12.80
	Triple	750	30	71.0	10.30
	Triple	900	35	60.0	8.70
349F L – FIX	Double	600	24	84.0	12.20
	Triple	750	30	68.0	9.90
	Triple	900	35	58.0	8.40
352F – VG	Double	600	24	89.0	12.90
	Triple	750	30	72.0	10.40
	Triple	900	35	61.0	8.80
374D L	Double	650	26	105.2	15.20
	Double	750	30	92.0	13.30
	Double	900	35	77.8	11.30
374F L*	Double	650	26	105.5	15.30
	Double	750	30	92.3	13.40
	Double	900	35	78.0	11.30
390D L	Double	650	26	118.9	17.20
	Double	750	30	104.1	15.10
	Double	900	35	87.8	12.70
390F L**	Double	650	26	119.4	17.30
	Double	750	30	104.5	15.20
	Double	900	35	88.1	12.78

*Reach boom 7.8 m (25'7"); 3.8 m³ (5.0 yd³) GD bucket; R4.67m (15'4") stick.

**Reach boom 10.0 m (32'10"); 3.9 m³ (5.1 yd³) GD bucket; R5.5m (18'1") stick.

NOTE: Belgium sourced excavators have different ground pressures. See Technical Data Sheets.

QUICK COUPLER SYSTEMS

Quick couplers can greatly increase a machine's versatility and productivity. They make it much easier to switch attachments which can increase utilization. Quick couplers also encourage changing buckets when the application changes, rather than continue to use a less efficient bucket. Example: An application that is predominately dirt with occasional pockets or seams of rock. Without a quick coupler the owner may choose to live with a rock bucket but, rock buckets are normally smaller and heavier which reduces performance in a dirt application. A quick coupler allows the use of the rock bucket in the rock and a GP bucket in the dirt.

Caterpillar offers two main types of quick couplers. The first is a dedicated type. A typical system substitutes hooks on the bucket for the pin-on hinges used with conventional buckets. The mating portion is pinned on the stick and bucket linkage. It slips into the hooks to secure the bucket or other attachment.

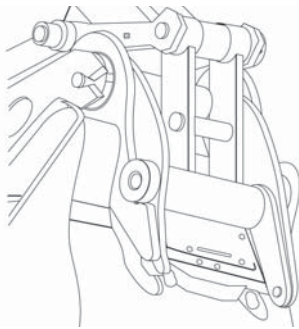

Dedicated
Hook-type

Advantages:

Bucket tip radius (distance from the bucket pivot point to the bucket tip) does not increase. Increased tip radius reduces curl and stick forces which can reduce the loadability of the bucket. The hook type coupler also does not add appreciable weight at the end of the stick. Keeping the tip radius and weight the same ensure no compromise in performance. The machine portion of the hook type coupler can be designed to allow more than one machine to use the same buckets.

Disadvantages:

The hook type system requires special buckets. Conventional pin-on buckets cannot be used. The ability to use buckets on more than one machine requires careful application analysis. Larger machines generate forces that can destroy the wrong buckets. Smaller machines with the wrong bucket may develop loads in excess of the machine's capability. Even if the machine can handle the loads, the tip radius may be too large to allow the bucket to load properly. With the flexibility of a quick coupler comes the responsibility to make sure the bucket or other attachments are properly sized for each application.

The second type of quick coupler is the pin grabber type. This device pins on the stick and bucket linkage and grabs the bucket pins on standard pin-on buckets.

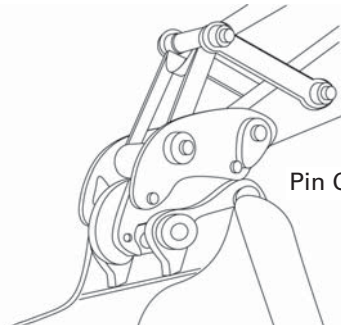

Pin Grabber

Advantages:

The advantage of the pin grabber is that it will pick up standard pin-on buckets. No need to purchase new attachments that will fit the system.

Disadvantages:

The pin grabber is mounted between the stick and the bucket which increases the tip radius. The amount of increase depends on the pin grabber's manufacturer. Increasing tip radius can compromise performance by decreasing bucket forces. The coupler also adds weight and reduces the payload capability.

Pin grabbers are required to mate up with existing bucket pins. Because different machines require different pin spreads and diameters, they offer very limited ability to match with buckets from other machines.

Both types of quick couplers offer cab activated ... this allows an attachment change in 30 seconds or less.

MINI HYDRAULIC EXCAVATORS

Dual Lock Pin Grabber Couplers

Dual Lock Pin Grabber Couplers allow work tools to be changed quickly — improving overall production and increasing machine versatility. A coupler is pinned on in place of the bucket with standard pins.

The **Dual Lock Coupler** is available in a standard pin grabber design for use on machines sized from 301.4C-308E2 CR SB. There are two types of Dual Lock Pin Grabber Couplers – Mechanical and Hydraulic (fully operable from the cab).

The **Dual Lock Tilt Coupler** allows for 180° of rotation while providing a reliable high torque actuator with few moving parts. The 180° rotation reduces the need for additional equipment on the job site, while increasing productivity and profitability.

Visible Secondary Lock

Cat Dual Lock Pin Grabber Couplers maintain a tight fit throughout the life of the coupler with an innovative wedge design. Primary and secondary locking systems are totally independent. The primary locking system consists of a locking wedge mechanism. An anti-rotation locking system into the actuator for the primary locking wedge is automatic and ensures the primary lock remains fully engaged even when used with high energy vibratory tools.

The secondary locking system incorporates a spring-loaded rotating lock that automatically locks on the front pin on the work tool during coupling. Spring applied, hydraulically released on the hydraulic coupler, and spring applied, mechanically released on the mechanical coupler.

Dual Lock Couplers were designed with the operator in mind allowing the secondary lock to be clearly visible from the cab.

Productivity

As with any quick coupler, the Dual Lock quickly changes between attachments, allowing one machine to be used for multiple tasks on the job site. The ability to see when the coupler is open or closed makes it intuitive to use, saving time when changing tools.

Dual Lock Couplers can engage and disengage any compatible Cat bucket or work tool attachment equipped with pins. The pin grabber design allows for buckets to be turned around in “front shovel” mode on both the Dual Lock and the Dual Lock Tilt Coupler.

The ease of operation and quickness of tool change-over maximizes productivity on the job site. The coupler is easy to operate, regardless of user skill level, and it's easier to train new operators to use. The ability to see when the coupler is open and closed saves time whenever a tool is changed. The elimination of the locking bar allows for operation regardless of boom, stick and machine position.

Dual Lock Pin Grabber Couplers meet Australian Standard AS 4772 and European EN-474-1.

Pin grabber couplers allow work tools to be changed quickly — improving overall production and increasing machine versatility. A coupler is pinned on in place of the bucket with standard pins, and can be easily removed should the need arise to mount a tool directly to the stick.

The Pin Grabber Coupler is designed for use on machines sized from 311-385 — and is designed to engage and disengage the same range of work tools as previous pin grabber couplers.

No dimensional or interface changes have been made to this coupler. However, a new patent-pending concept in the locking mechanism inside Center-Lock brings many benefits to the operator.

Compliant

The Cat Pin Grabber Coupler gives operators confidence through its patent pending locking system and visible locking mechanism. Couplers meet or exceed latest EN and ISO safety standards: EN474 and ISO/DIS 13031.

Visible Secondary Lock

The Pin Grabber Coupler was designed with the operator in mind. The secondary lock is clearly visible from the cab, providing an obvious indicator of coupler status: open or closed. The ability to see the lock on the front pin give the operator confidence and makes changing tools faster, while giving everyone on the job site reassurance that the Pin Grabber is locked tight.

Job Site Confidence

From engagement, all while working, to the time the attachment is disengaged, you can be completely confident attachments are connected properly.

From the operator's seat, visual and audible indicators help assure attachment is coupled. Your Cat excavator hydraulics, mechanisms inside the coupler, along with digging forces assure the attachment operates as expected.

The Cat Pin Grabber Coupler meets and exceeds safety standards allowing you to work anywhere in the world.

Productivity

As with any quick coupler, the Pin Grabber changes between attachments in seconds, allowing one machine to be used for multiple tasks on the job site.

The ease of operation and quickness of tool change-over maximizes productivity on the job site. The coupler is easy to operate, regardless of user skill level, and it's easier to train new operators to use. The ability to see when the coupler is open and closed saves time whenever a tool is changed. The elimination of the locking bar allows for operation regardless of boom, stick and machine position.

The Pin Grabber Coupler can pick up many buckets in reverse "front shovel" position for better control in utility work and precise digging and grading operations. Many competitive buckets can be engaged, making the Cat Pin Grabber invaluable in mixed fleets or rental fleets.

The Cat CW quick coupler can pick up any work tool and is equipped with a wedge-style locking system minimizing break-out force loss. The CW is highly suitable for harsh applications, such as demolition and quarries. The CW has become the industry standard in EAME. It is interchangeable with different machine classes, and has been designed for use with more than 700 different machines, both Cat and non Cat.

The Cat CW Series is available in a spindle and hydraulic version. A spindle version can easily be modified into a hydraulic version and vice versa.

Additional Benefit:

Hoisting hooks — To make the CW Series more versatile, hoisting hooks are available from 2 metric tons (2.2 tons) up to 20 metric tons (22 tons) capacity for maximum lifting capacity.

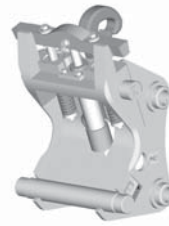

Hydraulic Version

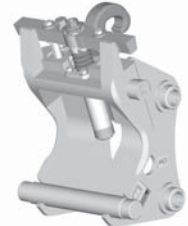

Spindle Version

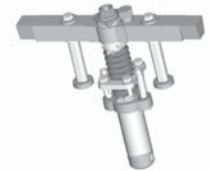
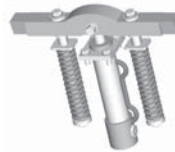

Specifications

		CW-05	CW-10	CW-20	CW-20S	CW-30	CW-30S			
Weight	kg	25	75	190	180	230	220			
	lb	55	165	419	397	507	485			
Dimensions										
	Width	mm	175	310	550	420	550	420		
		in	6.9	12.2	21.7	16.5	21.7	16.5		
Length	mm	200	300	475	475	475	475			
	in	7.9	11.8	18.7	18.7	18.7	18.7			
Hoisting-hook	metric ton	2	4	5/10	5/10	5/10	5/10			
	ton	2.2	4.4	5.5/11.0	5.5/11.0	5.5/11.0	5.5/11.0			
Excavator-class	metric ton	<3.5	3.5-10.5	7.5-15	7.5-15	15-25	15-25			
	ton	<3.9	3.9-11.6	8.3-16.5	8.3-16.5	16.5-27.6	16.5-27.6			
Spindle Version		X	X	X	X	X	X			
Hydraulic Version		X	X	X	X	X	X			
		CW-40	CW-40S	CW-45	CW-45S	CW-55	CW-55S	CW-70		
Weight	kg	240	230	440	400	760	580	1300		
	lb	529	507	970	882	1676	1279	2866		
Dimensions										
	Width	mm	550	420	690	550	830	560	840	
		in	21.7	16.5	27.2	21.7	32.7	22.0	33.1	
Length	mm	475	475	570	570	650	650	875		
	in	18.7	18.7	22.4	22.4	25.6	25.6	34.4		
Hoisting-hook	metric ton	5/10	5/10	14	14	20	20	20		
	ton	5.5/11.0	5.5/11.0	15.4	15.4	22.0	22.0	22.0		
Excavator-class	metric ton	20-30	20-30	25-40	25-40	35-65	35-65	65-90		
	ton	22.0-33.1	22.0-33.1	27.6-44.1	27.6-44.1	38.6-71.7	38.6-71.7	71.7-99.2		
Spindle Version		X	X	X	X	X	X	N/A		
Hydraulic Version		X	X	X	X	X	X	X		

CW-40 and CW-40S are not suitable for machine exceeding 27 metric tons (29.8 ton), which are used under heavy working conditions like rocky soils and demolition work, we highly recommend the usage of quick coupler CW-45(S).

Matching Guide

Machine	Linkage Family	Quick Coupler Model	
		Standard	Narrow
300.9D		—	N/A
301.4C		CW-05	N/A
301.7D		CW-05	N/A
301.7D CR		CW-05	N/A
302.2D		CW-05	N/A
302.4D		CW-05	N/A
302.7D CR		CW-05	N/A
303.5E CR		CW-05	N/A
304E CR		CW-05	N/A
305E CR		CW-05	N/A
305.5E CR		CW-05	N/A
312D		CW-20	CW-20S
315D L		CW-30	CW-30S
319D		CW-30	CW-30S
320D	B1, CB	CW-40	CW-40S
320D RR	B1	CW-40	N/A
321D CR	B1	CW-40	N/A
323D L	B, C	CW-40	CW-40S
329D**	C	CW-40	CW-40S
329D	D	CW-45	CW-45S

Machine	Linkage Family	Quick Coupler Model	
		Standard	Narrow
336D	D	CW-45	CW-45S
336D	E	CW-45	CW-45S
349D2/349E	TB, UB	CW-55	CW-55S
365C L	VB, WB	CW-70	N/A
385C	HJ, JB	CW-70	N/A
M313D		CW-20	CW-20S
M315D		CW-20	CW-20S
M316D		CW-20	CW-20S
M318D		CW-30	CW-30S
M322D		CW-40	CW-40S
330C UHD*	UHD linkage	CW-40	CW-40S
345C L UHD*	UHD linkage	CW-40	CW-40S
365C L UHD*	UHD linkage	CW-40	CW-40S
385C L UHD*	UHD linkage	CW-40	CW-40S

*Take note that UHD quick couplers have a special shape for optimal working range with Cat demolition work tools. Please contact your Cat dealer for UHD couplers for non-current Cat machines.

**For operation under heavy working conditions, like rocky soils and demolition work, we highly recommend the usage of quick coupler CW-45(S).

Machine Linkage

		312	315	B1	S	C	D	F/T	U/V/G
Pin diameters									
Front (stick)	mm	65	70	80	80	80	90	100	110
	in	2.6	2.8	3.1	3.1	3.1	3.5	3.9	4.3
Rear (link)	mm	65	70	80	80	80	90*	100**	90**
	in	2.6	2.8	3.1	3.1	3.1	3.5*	3.9**	3.5**
Pin spread range									
Minimum	mm	360	390	441	441	470	470	550	580
	in	14.2	15.4	17.4	17.4	18.5	18.5	21.7	22.8
Maximum	mm	420	463	516	516	520	520	600	640
	in	16.5	18.2	20.3	20.3	20.5	20.5	23.6	25.2
Face spread range									
Minimum	mm	220	277	306	306	347	380	420	495
	in	8.7	10.9	12.0	12.0	13.7	15.0	16.5	19.5
Maximum without shims	mm	226	281	312	312	353	386	441	511
	in	8.9	11.1	12.3	12.3	13.9	15.2	17.4	20.1
Maximum with shims	mm	258	315	344	344	385	418	458	557
	in	10.2	12.4	13.5	13.5	15.2	16.5	18.0	21.9
Other specifications									
Weight with pins	kg	286	326	443	443	594	640	1035	1130
	lb	631	719	977	977	1310	1411	2282	2491
Weight without pins	kg	265	295	400	400	549	579	949	1025
	lb	584	650	882	882	1210	1276	2092	2260
Pressure rating	bar	400	400	400	400	400	400	400	400
	psi	5802	5802	5802	5802	5802	5802	5802	5802

*Requires (2) sleeves.

**Requires (3) sleeves.

- Quick Coupler
- EAME
 - Specifications
 - Matching Guide

Hydraulic Excavators

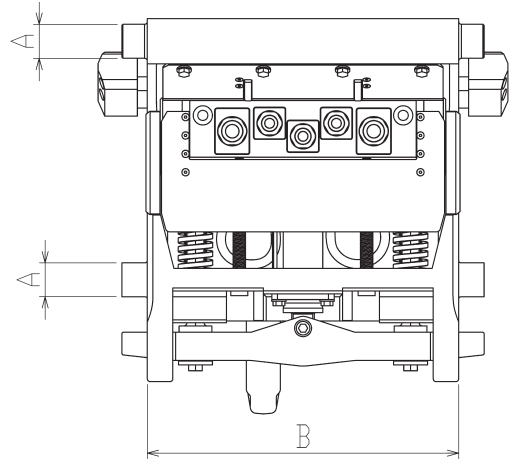
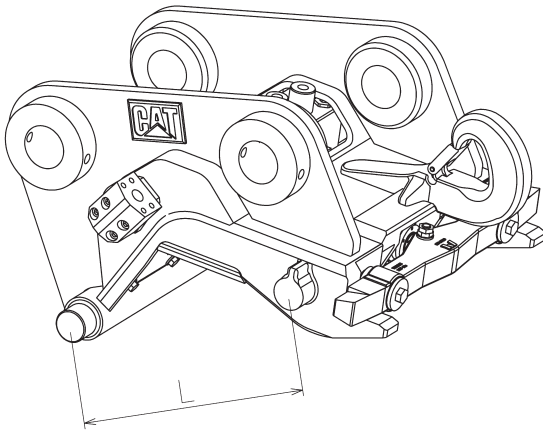

7

Auto-Connect Quick Coupler

The Auto-Connect quick coupler automates tool exchange fully, so operators can change work tools quickly, from the safety and comfort of their cabs. Tool changes become a matter of seconds. Built on the field proven quick coupler CW platform, the unique design of the Auto-Connect prevents ruptured hoses and oil spills, avoiding unplanned downtime.

Full Contamination Control on Both Quick Coupler and Work Tool:

A sliding cover keeps any dust and debris away from the hydraulic area, protecting the fluid connectors when not in use. Seals on both the Quick Coupler and the work tool cover have been included to close the gap with the cartridges, ensuring full contamination control. Rigid work tools without hydraulics, like buckets, do not need conversion to be picked up by the Auto-Connect quick coupler, avoiding unnecessary expenses. Due to the location of the hydraulic coupling unit, it's protected against damage from outside.

Plug-and-Perform System:

Auto-Connect is a “plug-and-perform” system based on Caterpillar’s dedicated CW platform, and fits directly to the machine and existing controls. The Auto-Connect is controlled via the Quick coupler actuation circuit. Combined with Cat Tool Control, it’s really easy for operators to select tools and make fast changeovers. With features like Auto Depressurization as standard no additional hydraulic components are required.

Specifications for Cat Wedge Auto-Connect Quick Coupler

		CWAC-40
Weight (approximate)	kg	340
	lb	750
QC-pins (A)	mm	60
	in	2.4
Width (B)	mm	550
	in	21.7
Length (L)	mm	475
	in	18.7
Hoisting-hook	metric ton	10
	ton	11
Total Fluid Connectings		5
Hose Couplings High Flow		2× 1"
Hose Couplings Medium Flow		2× 1/2"
Hose Couplings Extra/Drain		1× 1/2"

CWAC-40 is interchangeable with CW-30 and CW-40.

Please note that the coupler and the tools have to match the correct carrier.

Matching Guide

Quick Coupler	Linkage	Hydraulic Excavators
CWAC-40	—	M315D/M316D
CWAC-40	—	M318D/M322D
CWAC-40	—	315D/316E/318E
CWAC-40	—	319D
CWAC-40	B	320D/320E/321D/323D/323E

RIPPING & LOADING IN QUARRIES

The “Rip & Load” concept includes a large mass excavator equipped with a hydraulic quick coupler, a rock bucket and a ripper tine. The ripper tine is used to disrupt the in-situ rock formation, after which same excavator switches to the bucket to load the rock. This system is used where economical, environmental or legal issues prevent or restrict the use of explosives. In these situations, depending on geology, ripping either reduces the amount of explosives necessary, or replaces explosives all together.

Advantages:

- Reduction or elimination of blasting costs.
- Reduced safety risks.
- Smaller environmental impact (less noise and vibrations).
- Less exposure to precipitation, resulting in less water damage.
- Less waste (up to 35% reduction).
- Less internal cracks, resulting in higher quality product.
- Work areas can be closer to existing infrastructures.
- Fewer machines and personnel.
- Increased versatility with quick coupler (different buckets, hammers).
- Lower Cost per Ton.

Rip and Load Hourly Production

(With Hydraulic Quick Coupler)

Model	Metric Tons/Hour	Short Tons/Hour
345C/345D	150 - 300	165 - 330
365C	200 - 400	220 - 440
385C	300 - 500	330 - 550
5110B	400 - 600	440 - 660
5130B	600 - 800	660 - 880

Rippability

Refer to “Tip Selection”, “Estimating Ripping Production” and “Use of Seismic Velocity Charts” in the Track-type Tractors section. This information generally applies to usage of a ripper tine on the mass excavator.

Rippability Comparison between LHEX and LTTT

The excavator ripping technique is different from production ripping with a track-type tractor. The track-type tractor pulls the ripper(s) through the rock mass at a constant rate, whereas the excavator uses its stick-and curl forces to break material away from a horizontal or vertical face. Forward visibility in the excavator allows the operator to position the ripper tooth and attack geological discontinuities to assist the ripping process.

In ripping and loading, the ripper is typically used between 15% and 20% of the hour preparing the material. Tool change time, when using the hydraulic quick coupler, is insignificant with 2% to 6%. The remainder of the time is used for loading.

The ripping process improves bucket penetration which will increase service life of the bucket.

Cat Hydraulic Quick Couplers for Mass Excavators

Source: Cat Work Tools and Product Solutions — May not be available in all areas

(S) indicates narrow width version

		CW-30 (S)	CW-40 (S)	CW-45 (S)	CW-55 (S)	CW-70
Width	mm	550 (420)	550 (420)	690 (550)	830 (560)	840
	in	21.7 (16.5)	21.7 (16.5)	27.2 (21.7)	32.7 (22.0)	33.1
Length	mm	475	475	570	650	875
	in	18.7	18.7	22.4	25.6	34.4
Models Available						
S – Spindle		S	S	S	S	H
H – Hydraulic		H	H	H	H	
M318D						
320D		B linkage	CB linkage			
322C			S linkage	D linkage		
M322D						
323D		B linkage				
329D				D linkage		
336D						
345D						
365C						
385C						

7

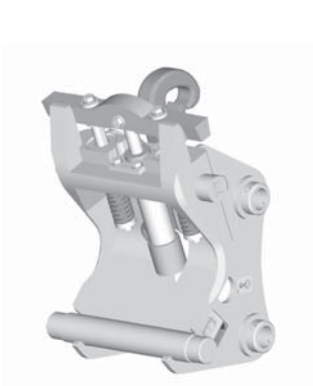
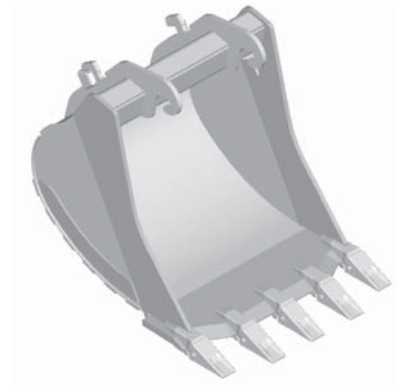
Cat® CW-70
Quick CouplerCat TR-70
Ripper with QCCat Bucket with
Quick Coupler Brackets

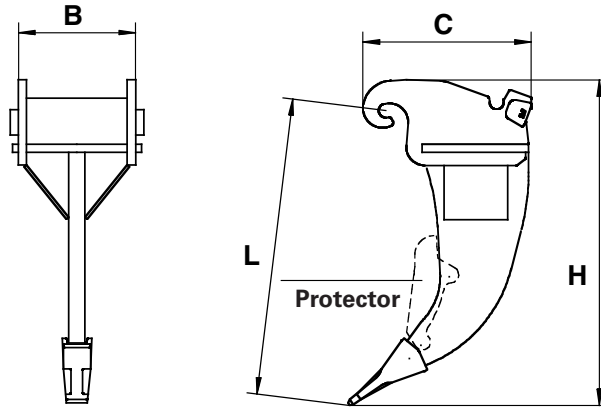

Specifications

		TR-20-N		TR-30-N		TR-40-N		TR-45-N		TR-55-N		TR-70-N	TR-99-N
		CA-20	CA-20S	CA-30	CA-30S	CA-40	CA-40S	CA-45	CA-45S	CA-55	CA-55S	CA-70	CA-70
Hinge Plate													
Weight*	kg	300	270	400	370	460	420	820	770	1200	1140	1760	1905
	lb	661	595	882	816	1014	926	1808	1698	2646	2513	3880	4200
Dimensions*													
B	mm	630	500	630	500	630	500	800	660	965	695	1000	1000
	in	24.8	19.7	24.8	19.7	24.8	19.7	31.5	26.0	38.0	27.4	39.4	39
L	mm	940		1105		1270		1435		1600		1700	1778
	in	37.0		43.5		50.0		56.5		63.0		66.9	70
C	mm	725		725		725		900		1050		1325	1452
	in	28.5		28.5		28.5		35.4		41.3		52.2	57
H	mm	1150		1250		1400		1650		1800		1980	2076
	in	45.3		49.2		55.1		65.0		70.9		78.0	82
Wear parts													
Tip size (family)		R300		R350		R450		R500		R500		R550	R550
Shank-protector**		N/A		N/A		X		X		X		X	X
Excavator-class	metric ton	7.5-15		15-25		20-30		25-40		35-65		65-90	90
	ton	8.3-16.5		16.5-27.6		22.0-33.1		27.6-44.1		38.6-71.7		71.7-99.2	99.2

*Weight and dimensions include standard Quick-Coupler hinge plates and exclude shank-protector.

**Shank-protector is optional.

Cat Ripper Tine for CW Hydraulic Quick Couplers

Source: Caterpillar WorkTools and Product Solutions — May not be available in all areas

	TR-30	TR-40	TR-45	TR-55	TR-70	TR-99
320D						
322C						
323D						
329D						
336D						
345D						
365C						
374D						
385C						
390D						JC linkage

Summary of Major Attachments
 ● 300.9D ● 301.4C ● 301.7D
 ● 302.2D ● 302.4D ● 302.7D CR

**Hydraulic
Excavators**

EQUIPMENT FOR ...	300.9D	301.4C	301.7D	301.7D CR
Undercarriage:				
Standard	●	●	●	—
Variable Width	●	●	●	●
Booms:				
Swing	●	●	●	●
Sticks:				
Medium	—	—	●	●
Long	●	●	●	●
Buckets (No. of)	—	—	14	—
Teeth:				
Long	●	●	●	●
Side Cutters:				
One-Piece Blade	●	●	●	●
Track Shoes:	Rubber Belt 230 mm (9")	Rubber Belt 230 mm (9")	Rubber Belt 230 mm (9")	Rubber Belt 230 mm (9")

7

EQUIPMENT FOR ...	302.2D	302.4D	302.7D CR
Undercarriage:			
Standard	●	●	●
Variable Width	—	—	—
Booms:			
Swing	●	●	●
Sticks:			
Medium	●	●	●
Long	●	●	●
Buckets (No. of)	17	17	—
Teeth:			
Long	●	●	●
Side Cutters:			
One-Piece Blade	●	●	●
Track Shoes:	Rubber Belt 250 mm (10")	Rubber Belt 250 mm (10")	Rubber Belt 230 mm (9")

NOTE: Number of buckets includes General Purpose, Trenching and Rock. Other types of buckets have not been included.
 All attachments may not be available in all sales areas.

Hydraulic Excavators

Summary of Major Attachments

- 303E CR ● 303.5E CR ● 304E CR
- 305E2 CR ● 305.5E2 CR ● 308E2 CR SB

EQUIPMENT FOR ...	303E CR	303.5E2 CR	304E2 CR	305E2 CR	305.5E2 CR	308E2 CR SB
Undercarriage:						
Standard	●	●	●	●	●	●
Booms:						
Swing	●	●	●	●	●	●
Sticks:						mm ft
Medium	●	●	●	●	●	1665 5'6"
Long	—	●	●	●	●	2210 7'3"
Teeth:						
Long	●	●	●	●	●	●
Light Duty Long	●	●	●	●	●	●
Short	—	●	●	●	●	●
Wide	●	●	●	●	●	●
Penetration	●	●	●	●	●	●
Sharp — Corner	●	●	●	●	●	●
Sharp — Center	●	●	●	●	●	●
Sharp — Twin	●	●	●	●	●	●
Heavy Duty Long	—	●	●	●	●	●
Heavy Duty Abrasion	—	●	●	●	●	●
Abrasion	●	●	●	●	●	●
Side Cutters:						
One-Piece Blade	●	●	●	●	●	●
Track Shoes:	Triple Grouser 300 mm (12") Rubber Belt 300 mm (12")	Triple Grouser 300 mm (12") Rubber Belt 300 mm (12")	Triple Grouser 350 mm (14") Rubber Belt 350 mm (14")	Triple Grouser 400 mm (16") Rubber Belt 400 mm (16")	Triple Grouser 400 mm (16") Rubber Belt 400 mm (16")	Rubber Belt 450 mm (18") Triple Grouser 450 mm (18") Triple Grouser with Pad 450 mm (18") Triple Grouser 600 mm (24")

NOTE: Number of buckets includes General Purpose, Trenching and Rock. Other types of buckets have not been included.
All attachments may not be available in all sales areas.

Summary of Major Attachments
 ● 311F L RR ● 312D2 ● 312D2 GC ● 312D2 L
 ● 313D2 ● 312E ● 312E L ● 313D2 LGP

**Hydraulic
Excavators**

EQUIPMENT FOR ...	311F L RR		312D2 312D2 GC 312D2 L 313D2		312E 312E L		313D2 LGP	
	mm	ft	mm	ft	mm	ft	mm	ft
Undercarriage:								
Standard	—		●		●		●	
Long (L)	●		●		●		—	
Booms:								
One-Piece Reach	●		●		●		—	
One-Piece Reach— HD	—		●		—		●	
Sticks:								
Short	—		—		2100	6'11"	—	
Medium	2250	7'5"	2500	8'2"	2500	8'2"	—	
Medium— HD	—		2500	8'2"	—		2500	8'2"
Intermediate	—		—		2800	9'2"	—	
Long	2800	9'2"	3000	9'10"	3000	9'10"	3000	9'10"
Booms:								
Two-Piece VA	—		—		●		—	
Buckets (No. of)	19		19		14		14	
Teeth*:								
Abrasion — HD	●		●		●		●	
Long (G.P.)	●		●		●		●	
Long — HD	●		●		●		●	
Short (Rock)	●		●		●		●	
Penetration	●		●		●		●	
Wide (Spade)	●		●		●		●	
Sharp — Center	●		●		●		●	
Sharp — Corner	●		●		—		●	
Side Cutters:								
One-Piece Blade	●		●		●		●	
Track Shoes:								
	Triple Grouser 500, 600, 700, 770 mm (20", 24", 28", 30")		Triple Grouser 500, 600, 700, 770 mm (20", 24", 28", 30")		Triple Grouser 500, 600, 700, 770, mm (20", 24", 28", 30")		Single Grouser 960 mm (38") Triple Grouser 500 mm (20")	
Blade	●		●		●		—	

*J Series Tooth System for 311F L RR, 312D2, 312D2 GC, 312D2 L and 313D2 models.

NOTE: Number of buckets includes General Purpose, Trenching and Rock. Other types of buckets have not been included.
 All attachments may not be available in all sales areas.

EQUIPMENT FOR ...	314E CR 314E LCR		316E L		318D2 L		318E L	
Undercarriage:								
Standard	●		—		—			—
Long (L)	●		●		●			●
Booms:								
One-Piece Reach	●		●		●			●
Parallel Offset	●		—		—			—
Sticks:	mm	ft	mm	ft	mm	ft	mm	ft
Short	2100	6'11"	2250	7'4"	—		2250	7'5"
●	2130	6'11"	2600	8'6"	2600	8'6"	2600	8'6"
Medium	2500	8'2"	2900	9'6"	2900	9'6"	2900	9'2"
Intermediate	2800	9'2"	—		—		—	
Long	3000	9'10"	3100	10'2"	—		3100	10'2"
Booms:								
One-Piece Mass	●		●		●			●
Two-Piece VA	●		●		—			●
Buckets (No. of)	14		18		18		18	
Teeth*:								
Abrasion — HD	●		—		—			—
Long (G.P.)	●		—		—			—
Long — HD	●		—		—			—
Short (Rock)	●		—		—			—
General Duty	—		●		●			●
Penetration	●		●		●			●
Penetration Plus	—		●		●			●
Wide	—		●		●			●
Wide (Spade)	●		—		—			—
Extra Duty	—		●		●			●
Spike	—		●		●			●
Double Spike	—		●		●			●
Sharp — Center	●		—		—			—
Sharp — Corner	●		—		—			—
Side Cutters:								
One-Piece Blade	●		●		●			●
Track Shoes:	Triple Grouser 500, 600, 700 mm (20", 24", 28")		Triple Grouser 500, 600, 700 mm (20", 24", 28")		Triple Grouser 500, 600, 700 mm (20", 24", 28")		Triple Grouser 500, 600, 700, 790 mm (20", 24", 28", 31")	
Blade	●		—		—		—	

*K Series Tooth System for 316E L, 318D2 L and 318E L models.

NOTE: Number of buckets includes General Purpose, Trenching and Rock. Other types of buckets have not been included.

All attachments may not be available in all sales areas.

● 320D2 ● 320D2 GC ● 320D2 L ● 320E ● 320E L
● 320E RR ● 320E LRR ● 320F L

**Hydraulic
Excavators**

EQUIPMENT FOR ...	320D2 320D2 GC 320D2 L		320E 320E L		320E RR 320E LRR		320F L	
	mm	ft	mm	ft	mm	ft	mm	ft
Undercarriage:								
Standard	●		●		●		●	
Long (L)	●		●		●		●	
Booms:								
One-Piece Reach	●		●		●		●	
One-Piece Reach — HD	●		●		●		—	
Two Pieces — VA	—		●		—		●	
Sticks:								
Short	2900	9'6"	2500	8'2"	—		—	
Short — HD	2500	8'2"	2500	8'2"	—		—	
● — HD	2900	9'6"	—		—		—	
Medium	—		2920	9'6"	2920	9'6"	2920	9'6"
Medium — HD	—		2920	9'6"	2920	9'6"	—	
Super Long Reach (SLR)	6280	20'7"	—		—		—	
Booms:								
One-Piece Mass	●		—		—		—	
Sticks:								
Short	2400	7'11"	—		—		—	
Bucket Family		B1		B1		B1		B1
Buckets (No. of)		32		—		—		—
Teeth:								
Abrasion — HD	●		—		—		—	
Long (G.P.)	●		—		—		—	
Long — HD	●		—		—		—	
Short (Rock)	●		—		—		—	
Penetration	●		—		—		—	
Wide (Spade)	●		—		—		—	
Sharp — Center	●		—		—		—	
Sharp — Corner	●		—		—		—	
Side Cutters:								
One-Piece Blade	●		—		—		—	
Track Shoes:								
		Triple Grouser 600, 700, 790 mm (24", 28", 31") Double Grouser 600 mm (24")		Triple Grouser 600, 700, 790, 900 mm (24", 28", 31", 35")		Triple Grouser 600, 700, 790 mm (24", 28", 31")		Triple Grouser 600, 700, 790 mm (24", 28", 31")

NOTE: Number of buckets includes General Purpose, Trenching and Rock. Other types of buckets have not been included.
All attachments may not be available in all sales areas.

EQUIPMENT FOR ...	323D2 L		323E L 323E LN		323E SA		323F L	
	Undercarriage:							
Standard	—		—		●		—	
Long (L)	●		●		—		●	
Long (LN)	—		●		—		—	
Booms:								
One-Piece Reach	●		—		●		●	
One-Piece Reach — HD	●		●		●		●	
One-Piece Reach — ES	—		—		—		—	
Two Pieces — VA	—		●		●		—	
Sticks:	mm	ft	mm	ft	mm	ft	mm	ft
Short	2900	9'6"	2500	8'2"	2500	8'2"	2900	9'6"
Short — HD	2500	8'2"	2500	8'2"	2500	8'2"		
● — HD	2900	9'6"						
Medium	—		2920	9'6"	2920	9'6"	2900	9'6"
Medium — HD	—		2920	9'6"	2920	9'6"		
Medium — ES	—		—		—		2900	9'6"
Medium Thumb Ready — ES	—		—		—		2900	9'6"
Long	—		—		—		3900	12'10"
Super Long Reach (SLR)	—		—		—		6280	20'7"
Booms:								
One-Piece Mass	●		—		—		—	
Sticks:	mm	ft						
Short	1900	6'2"	—		—		—	
●	2400	7'10"	—		—		—	
Bucket Family	B1, CB2		B1		B1		B1	
Buckets (No. of)	18		—		—		—	
Teeth:								
Abrasion — HD	●		—		—		—	
Long (G.P.)	●		—		—		—	
Long — HD	●		—		—		—	
Short (Rock)	●		—		—		—	
Penetration	●		—		—		—	
Wide (Spade)	●		—		—		—	
Sharp — Center	●		—		—		—	
Sharp — Corner	●		—		—		—	
Side Cutters:								
One-Piece Blade	●		—		—		—	
Track Shoes:	Triple Grouser 600, 700, 790, 900 mm (24", 28", 31", 35") Double Grouser 600, 700 mm (24", 28")		Triple Grouser 500, 600, 700, 790, 900 mm (20", 24", 28", 31", 35")		Triple Grouser 550 mm (22")		Single Grouser 600 mm (24") Triple Grouser 790 mm (31")	

NOTE: Number of buckets includes General Purpose, Trenching and Rock. Other types of buckets have not been included.
All attachments may not be available in all sales areas.

EQUIPMENT FOR ...	325F L		326D2 L		326F 326F L 326F LN	
	mm	ft	mm	ft	mm	ft
Undercarriage:						
Standard	—		●		●	
Long (L)	●		●		●	
Long Narrow (LN)	—		—		●	
Booms:						
One-Piece Reach	●		●		●	
One-Piece Reach — HD	—		●		●	
Two Pieces — VA	●		—		●	
Sticks:						
Short	—		2500	8'2"	2500	8'2"
Medium	2920	9'6"	2950	9'8"	2950	9'8"
Medium — HD	—		2950	9'8"	—	
Long	—		—		3600	11'10"
Super Long Reach (SLR)	—		7850	25'9"	7850	25'9"
Bucket Family	B1		CB1		CB1	
Buckets (No. of)	—		32		—	
Teeth:						
Abrasion — HD	—		●		—	
Long (G.P.)	—		●		—	
Long — HD	—		●		—	
Short (Rock)	—		●		—	
Penetration	—		●		—	
Wide (Spade)	—		●		—	
Sharp — Center	—		●		—	
Sharp — Corner	—		●		—	
Side Cutters:						
One-Piece Blade	—		●		—	
Side Bar Protector	—		●		—	
Track Shoes:						
	Triple Grouser 600, 790 mm (24", 31")		Double Grouser 600 mm (24") Triple Grouser 600, 700, 790 mm (24", 28", 31")		Single Grouser 600 mm (24") Double Grouser 600 mm (24") Triple Grouser 700, 790 mm (28", 31")	

NOTE: Number of buckets includes General Purpose, Trenching and Rock. Other types of buckets have not been included.
All attachments may not be available in all sales areas.

EQUIPMENT FOR ...	330D2 L		330F 330F L 330F LN		335F L	
	Undercarriage:					
Standard	●		●		—	
Long (L)	●		●		●	
Long Narrow (LN)	—		●		—	
Booms:						
One-Piece Reach	●		●		●	
One-Piece Reach — HD	—		●		—	
Sticks:	mm	ft	mm	ft	mm	ft
Short	2650	8'8"	2650	8'8"	—	—
Short — HD	—	—	—	—	2650	8'8"
Medium	3200	10'6"	3200	10'6"	—	—
Medium — HD	—	—	—	—	3200	10'6"
Long	—	—	3750	12'4"	3750	12'4"
Super Long Reach (SLR)	7850	25'9"	7850	25'9"	—	—
Booms:						
One-Piece Mass	●		—		—	
Sticks:	mm	ft				
Short	2500	8'2"	—		—	
Bucket Family	CB1, CB2, DB		B1, CB2		CB, CB2	
Buckets (No. of)	32		—		—	
Teeth:						
Abrasion — HD	●		—		—	
Long (G.P.)	●		—		—	
Long — HD	●		—		—	
Short (Rock)	●		—		—	
Penetration	●		—		—	
Wide (Spade)	●		—		—	
Sharp — Center	●		—		—	
Sharp — Corner	●		—		—	
Side Cutters:						
One-Piece Blade	●		—		—	
Track Shoes:	Double Grouser 600 mm (24") Triple Grouser 600, 700, 800 mm (24", 28", 32")		Double Grouser 600 mm (24") Triple Grouser 700, 800 mm (28", 32")		Triple Grouser 600, 700, 850 mm (24", 28", 33")	

NOTE: Number of buckets includes General Purpose, Trenching and Rock. Other types of buckets have not been included.
All attachments may not be available in all sales areas.

Summary of Major Attachments

- 349D2 ● 349D2 L ● 349E ● 349E L ● 349F L
- 352F ● 374D L ● 374F L ● 390D L ● 390F L

EQUIPMENT FOR ...	336D2		349D, 349D L		374D L		390D L	
	336D2 L		349E, 349E L		374F L		390F L	
	mm	ft	mm	ft	mm	ft	mm	ft
Undercarriage:								
Standard	●		●		—		●	
Long (L) — VG	—		●		●		●	
Long (L) — FIX	●		●		—		—	
Extreme Service (ES)	—		—		●		—	
Booms:								
One-Piece Reach	●		●		●		●	
One-Piece — GP	—		—		—		●	
One-Piece Reach — HD	—		●		—		—	
Sticks:								
Short	2800	9'2"	2900	9'6"	2840	9'2"	2920	9'5"
●	—		3350	11'0"	3600	11'8"	3400	11'2"
●	—		—		4150	13'8"	3700	12'1"
●	—		—		4670	15'4"	4400	14'4"
Short — HD	—		2900	9'6"	—		5500	18'1"
● — HD	—		3350	11'0"	—		—	
Medium	3200	10'6"	—		—		—	
Long	3900	12'10"	3900	12'10"	—		—	
Long — HD	—		3900	12'10"	—		—	
Long Reach — HD	—		4300	14'1"	—		—	
Booms:								
One-Piece Mass	●		—		●		●	
One-Piece Mass — HD	—		●		—		—	
Sticks:								
Short	2150	7'1"	2500	8'2"	2570	8'5"	2920	9'5"
●	2550	8'5"	3000	9'10"	3000	9'8"	3400	11'2"
Short — HD	—		2500	8'2"	—		—	
● — HD	—		3000	9'10"	—		—	
Bucket Family								
	DB, TB1		TB, UB		VB, WB		HB, JB	
Buckets (No. of)	34		32		24		14	
Teeth:								
Abrasion — HD	●		●		—		—	
Long (G.P.)	●		●		●		●	
Long — HD	●		●		●		●	
Short (Rock)	●		●		●		●	
Penetration	●		●		●		●	
Penetration Plus	—		●		●		●	
Wide (Spade)	●		—		—		—	
Sharp — Center	●		—		—		—	
Sharp — Corner	●		—		—		—	
Side Cutters:								
One-Piece Blade	●		CWTS		—		—	
Track Shoes:								
	Double Grouser 600 mm (24") Triple Grouser 600, 700, 800 mm (24", 28", 32")		Double Grouser 600, 750 mm (24", 30") Triple Grouser 600, 750, 900 mm (24", 30", 35")		Double Grouser 650, 750, 900 mm (26", 30", 35")		Double Grouser 650, 750, 900 mm (26", 30", 35")	

7

NOTE: Number of buckets includes General Purpose, Trenching and Rock. Other types of buckets have not been included. All attachments may not be available in all sales areas.

EQUIPMENT FOR ...	M313D		M315D		M316D		M318D		M322D	
Undercarriage:										
Wheeled	●		●		●		●		●	
Booms:										
One-piece	●		●		●		●		●	
VA	●		●		●		●		●	
VA + Boom Offset	●		●		●		—		—	
Sticks:	mm	ft	mm	ft	mm	ft	mm	ft	mm	ft
Short	2000	6'7"	2100	6'11"	2100	6'11"	2200	7'3"	2200	7'3"
Medium	2300	7'7"	2400	7'10"	2400	7'10"	2500	8'2"	2500	8'2"
Long	2600	8'6"	2600	8'6"	2600	8'6"	2800	9'2"	2900	9'6"
Industrial Drop Nose	2900	9'6"	—		3100	10'2"	3300	10'10"	—	
Buckets (No. of)	21		27		27		28		23	
Teeth:										
Abrasion	●		●		●		●		●	
Long (G.P.)	●		●		●		●		●	
Short (Rock)	●		●		●		●		●	
Penetration	●		●		●		●		●	
Wide	●		●		●		●		●	
Sharp	●		●		●		●		●	
Cab Riser:										
Fixed	—		—		—		—		—	
Hydraulic	—		—		—		●		●	
Tires:	10.00-20 16 PR 18R 19.5 XF 10.00-20 SR dual		10.00-20 16 PR 18R 19.5 XF 10.00-20 SR dual		10.00-20 16 PR 18R 19.5 XF 10.00-20 SR dual		10.00-20 16 PR 18R 19.5 XF 10.00-20 SR dual		11.00-20 16 PR 10.00-20 SR	

Work Tools	300.9D	301.4C, 301.7D, 301.7D CR	302.2D, 302.4D, 302.7D CR	303E CR, 303.5E CR, 303.5E2 CR	304E CR, 304E2 CR	305E CR, 305E2 CR, 305.5E CR, 305.5E2 CR	308E2 CR SB	311D LRR, 312E L, 314D CR, 314D LCR	315D L, 316E L	318E	319D L, 319D LN	M313D, M315D	M316D, M318D, M322D	320E L, 320E LRR, 321D CR, 323D	324D, 324E	329D, 329E	336D, 336E	349D2, 349E, 349F	365C L	374D	385C	390D
Auger		X	X	X	X	X	X															
Clean Up Buckets								X	X	X		X	X	X	X	X	X					
Contractor's Grapple								X	X	X	X	X	X	X	X	X	X	X	X	X	X	X
Demolition and Sorting Grapples								X	X	X	X	X	X	X	X	X	X	X	X	X	X	X
Digging Buckets	X	X	X																			
Ditch Cleaning Bucket	X	X	X	X	X	X	X	X	X	X		X	X	X	X	X	X	X	X			
Extreme Duty Bucket																	X	X		X		X
General Duty Bucket								X	X	X		X	X	X	X	X	X	X	X	X	X	X
General Duty, High Capacity Bucket																		X		X		X
General Duty WideTip								X	X					X	X	X	X	X				
General Purpose Bucket																			X		X	
Heavy Duty Bucket				X	X	X	X			X	X	X	X	X	X	X	X	X	X	X	X	
Heavy Duty Capacity						X																
Heavy Duty Power Bucket														X	X	X	X					
Heavy Duty Rock							X	X	X													
Hydraulic Hammer	X	X	X	X	X	X	X	X	X	X	X	X	X	X	X	X	X	X	X	X	X	
Mud Bucket		X	X	X	X	X	X															
Multi-Processor										X	X	X	X	X	X	X	X	X	X	X	X	X
Pulverizers								X	X	X	X	X	X	X	X	X	X	X				
Quick Coupler		X	X	X	X	X	X	X	X	X	X	X	X	X	X	X	X	X	X	X	X	X
Rippers				X	X	X	X		X	X	X	X	X	X	X	X	X	X	X	X	X	X
Severe Duty Bucket								X	X	X				X	X	X	X	X	X	X	X	X
Shear				X	X	X	X	X	X	X	X	X	X	X	X	X	X	X	X	X	X	X
Thumb – Pro Series							X	X	X	X	X			X	X	X						
Thumb – Utility			X	X	X	X	X	X	X	X	X			X	X	X						
Thumb – Stiff Link							X	X	X	X	X	X	X	X	X	X	X	X				
Tilting Ditch Cleaning Bucket		X	X	X	X	X																
Trash Grapple								X	X	X	X	X	X	X	X	X	X	X	X			
Vibratory Plate Compactor			X	X	X	X	X	X	X	X	X	X	X	X	X	X	X	X				

NOTE: Other attachments available upon request. Contact your Cat dealer.

CYCLE TIME ESTIMATING CHARTS

The digging cycle of the excavator is composed of four segments:

1. Load Bucket
2. Swing Loaded
3. Dump Bucket
4. Swing Empty

Total excavator cycle time is dependent on machine size (small machines can cycle faster than large machines) and job conditions. With excellent job conditions the excavator can cycle fast. As job conditions become more severe (tougher digging, deeper trench, more obstacles, etc.), the excavator slows down accordingly. As the soil gets harder to dig, it takes longer to fill the bucket. As the trench gets deeper and the spoil pile larger, the bucket has to travel farther and the upper structure has to swing farther on each digging cycle.

Spoil pile or truck location also affects cycle time. If a truck is located on the floor of the excavation beside material being moved, 10 to 17 second cycles are practical. The other extreme would be a truck or spoil pile located above the excavator 180° from the excavation.

In sewer construction work the operator may not be able to work at full speed because he has to dig around existing utilities, load the bucket inside a trench shield, or avoid people working in the area.

The Cycle Time Estimating Chart outlines the range of total cycle time that can be expected as job conditions range from excellent to severe. Many variables affect how fast the excavator is able to work. The chart defines the range of cycle times frequently experienced with a machine and provides a guide to what is an “easy” or a “hard” job. The estimator can then evaluate the conditions of his job and use the Cycle Time Estimating Chart to select the appropriate working range. A practical method of further calibrating the Cycle Time Estimating Chart is to observe excavators working in the field and correlate measured cycle times to job conditions, operator ability, etc.

The following table breaks down what experience has shown to be typical Cat excavator cycle times with

- no obstruction in the right of way
- above average job conditions
- an operator of average ability and
- 60°-90° swing angle.

These times would decrease as job conditions or operator ability improved and would get slower as conditions become less favorable.

CYCLE TIME -vs- JOB CONDITION DESCRIPTION

Fastest Possible

Fastest Practical

Typical Range

Slow



KEY

- A — Excellent
- B — Above Average
- C — Average
- D — Below Average
- E — Severe

- Easy digging (unpacked earth, sand gravel, ditch cleaning, etc.). Digging to less than 40% of machine’s maximum depth capability. Swing angle less than 30°. Dump onto spoil pile or truck in excavation. No obstructions. Good operator.
- Medium digging (packed earth, tough dry clay, soil with less than 25% rock content). Depth to 50% of machine’s maximum capability. Swing angle to 60°. Large dump target. Few obstructions.
- Medium to hard digging (hard packed soil with up to 50% rock content). Depth to 70% of machine’s maximum capability. Swing angle to 90°. Loading trucks with truck spotted close to excavator.
- Hard digging (shot rock or tough soil with up to 75% rock content). Depth to 90% of machine’s maximum capability. Swing angle to 120°. Shored trench. Small dump target. Working over pipe crew.
- Toughest digging (sandstone, caliche, shale, certain limestones, hard frost). Over 90% of machine’s maximum depth capability. Swing over 120°. Loading bucket in man box. Dump into small target requiring maximum excavator reach. People and obstructions in the work area.

Cycle Time Estimating Chart

Model		308E2 CR SB	311D LRR	312D, 312D L	315D L	319D L, 319D LN	M313D	M315D, M316D	M318D	M322D
Bucket Size	L	220	450	520	520	800	610	750	900	1050
	yd ³	0.30	0.59	0.68	0.68	1.05	0.80	0.98	1.18	1.37
Soil Type		← Packed Earth				→ Sand/Gravel →				
Digging Depth	m	1.8	1.5	1.8	3.0	3.0	3.0	3.0	3.0	3.0
	ft	6'0"	5'0"	6'0"	10'0"	10'0"	10'0"	10'0"	10'0"	10'0"
Load Bucket	min	0.08	0.07	0.07	0.07	0.09	0.05	0.06	0.06	0.08
Swing Loaded	min	0.03	0.06	0.06	0.08	0.09	0.05	0.05	0.06	0.06
Dump Bucket	min	0.03	0.03	0.03	0.03	0.03	0.03	0.03	0.03	0.04
Swing Empty	min	0.08	0.05	0.05	0.06	0.07	0.04	0.04	0.05	0.05
Total Cycle Time	min	0.22	0.21	0.21	0.24	0.28	0.17	0.18	0.20	0.23

Cycle Time Estimating Chart

Model		320D2	320D RR, 321D CR, 323D2	324D	328D LCR	329D	336D	349D2, 349E, 349F	365C L	385C
Bucket Size	L	800	800	1000	N/A	1100	1400	2400	1900	3760
	yd ³	1.05	1.05	1.31		1.44	1.83	3.0	2.5	5.0
Soil Type		←				→ Hard Clay →				
Digging Depth	m	2.3	2.3	3.2	N/A	3.2	3.4	4.0	4.2	5.6
	ft	8	8	10		10	11	13	14	18
Load Bucket	min	0.09	0.09	0.09	N/A	0.09	0.09	0.13	0.10	0.19
Swing Loaded	min	0.06	0.06	0.06	N/A	0.06	0.07	0.07	0.09	0.06
Dump Bucket	min	0.03	0.03	0.04	N/A	0.04	0.04	0.02	0.04	0.03
Swing Empty	min	0.05	0.05	0.06	N/A	0.06	0.07	0.06	0.07	0.07
Total Cycle Time	min	0.23	0.23	0.25	N/A	0.25	0.27	0.28	0.30	0.35

N/A = Not Applicable

CYCLE TIME ESTIMATING CHART														
CYCLE TIME	MACHINE SIZE CLASS													CYCLE TIME
	307C 308D CR 308D CR SB	311D	M313D 312D	M315D M316D 315D L	M318D 319D L 319D LN	M322D 320D 320D RR 321D CR 323D	324D	328D LCR	329D	336D	349D2 349E 349F	365C L	385C	
10 SEC.								N/A						0.17 min.
15								N/A						0.25 min.
20 SEC.								N/A						0.33 min.
25														0.42 min.
30 SEC.														0.50 min.
35														0.58 min.
40 SEC.														0.67 min.
45														0.75 min.
50 SEC.														0.83 min.
55														0.92 min.
60 SEC.														1.0 min.

N/A = Not Applicable

Cat 300 Series Mass Excavation booms and buckets coupled with the proper stick will help you move material faster and more efficiently in production excavation and loading applications. With the largest bucket, shortest stick and long undercarriage your excavator can often do the work of a larger machine. A longer stick and standard undercarriage make it ideal for loading on-highway trucks and general construction jobs.

MAXIMIZING PRODUCTION WITH A MASS EXCAVATOR

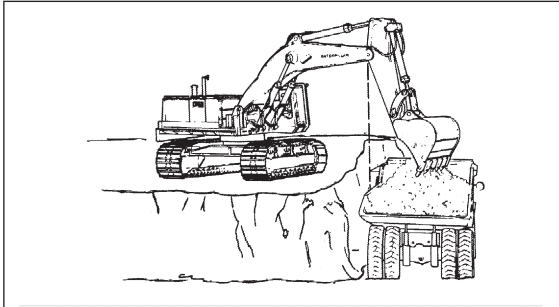

Ideal Bench Height and Truck Distance — For stable or consolidated materials, bench height should be about equal to stick length. For unstable materials it should be less. The most useful truck position is when the inside truck body rail is below the boomstick hinge pin.

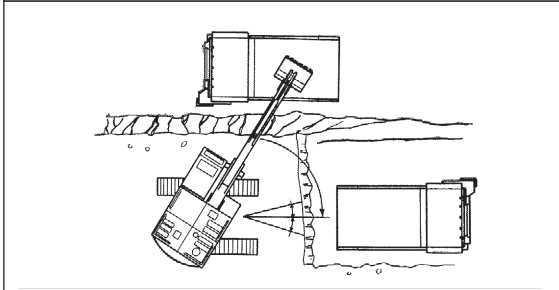

Optimum Work Zone and Swing Angle — For maximum production, the work zone should be limited to 15° either side of machine center or about equal to undercarriage width. Trucks should be positioned as close as possible to machine centerline. Two alternatives shown here.

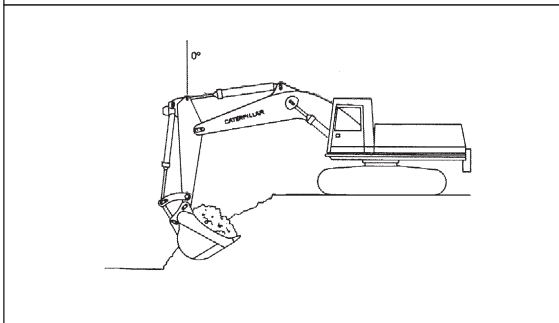

Best Distance from the Edge — The machine should be positioned so that the stick is vertical when the bucket reaches full load. If the unit is farther back, breakout force is reduced. If it is closer to the edge, undercutting may occur and time is wasted bringing the stick back out. Also, the operator should begin boom-up when the bucket is 75% of the way through the curl cycle. This should be as the stick nears the vertical position.

This example reflects the ideal situation. Not all points are usable on each job, but incorporation of as many of these points as possible will positively affect production.

SELECTING A MASS EXCAVATOR

Selecting a mass excavator model for optimum production requires matching the machine and bucket to the customer's production requirements, material, and haulers. The following 6-Step selection process will help you to consider the key factors which will impact machine selection. Failure to consider these key elements in the selection process may result in choosing a machine that is too small to efficiently handle the desired bucket size or to meet the production requirement. Selecting a mass excavator which is too large may lead to excessive loader wait time, creating excessive "load shocks" into the hauler, and/or overloading the hauler capacity.

Step 1

Determine the material type and bucket fill factor

Refer to the bucket fill factors table.

Example:

Average Blasted Rock = 75 to 90%

Step 2

Estimate the Cycle Time

Refer to the cycle time estimating chart.

Example:

$\frac{365\text{B in Hard Rock Digging}}{\text{Shot Rock}} = .43 \text{ to } .52 \text{ minute}$

Step 3

Calculate the Effective Cycles per Hour

Divide the 60 minute hour by cycle time and adjust for availability and efficiencies.

Example:

<i>Cycle Time</i>	0.48 minute
$\frac{60 \text{ minute hour}}{\text{Cycle Time}}$	$\frac{60}{0.48} = 125$
<i>Operator Skill/Efficiency</i>	0.9 (90%)
<i>Machine Availability</i>	0.95 (95%)
<i>Gen Operational Efficiency</i>	0.83 (50 min/hr)
<i>Effective Cycles per Hour</i>	$125 \times .9 \times .95 \times .83 = 89$

Step 4

Calculate the Required Bucket Capacity

Divide hourly production requirement by effective cycles per hour, adjust for material density and fill factor.

Example (Metric):

<i>Hourly Production Required</i>	500 Tons/hour
<i>Effective cycles/hour</i>	89

$$\frac{\text{Hourly Production Required}}{\text{Effective cycles/hour}} = \frac{\text{Required Payload}}{\text{Material Density/Loose}} = \frac{500}{89} = 5.6$$

<i>Material Density/Loose</i>	1.6 Ton/m ³
-------------------------------	------------------------

$$\frac{\text{Required Payload}}{\text{Material Density/Loose}} = \frac{\text{Bucket Payload}}{\text{Volume}} = \frac{5.6}{1.6} = 3.5 \text{ m}^3$$

<i>Fill Factor</i>	0.85 (85%)
--------------------	------------

$$\frac{\text{Bucket Payload}}{\text{Fill Factor}} = \frac{\text{Nominal Bucket Size}}{\text{Volume}} = \frac{3.5}{.85} = 4.1 \text{ m}^3$$

Example (English):

<i>Hourly Production Required</i>	550 tons/hour
<i>Effective cycles/hour</i>	89

$$\frac{\text{Hourly Production Required}}{\text{Effective cycles/hour}} = \frac{\text{Required Payload}}{\text{Material Density/Loose}} = \frac{550 \times 2000}{89} = 12,360 \text{ lb}$$

<i>Material Density/Loose</i>	2700 lb/yd ³
-------------------------------	-------------------------

$$\frac{\text{Required Payload}}{\text{Material Density/Loose}} = \frac{\text{Bucket Payload}}{\text{Volume}} = \frac{12,360}{2700} = 4.6 \text{ yd}^3$$

<i>Fill Factor</i>	0.85 (85%)
--------------------	------------

$$\frac{\text{Bucket Payload}}{\text{Fill Factor}} = \frac{\text{Nominal Bucket Size}}{\text{Volume}} = \frac{4.6}{.85} = 5.4 \text{ yd}^3$$

Step 5

Select Mass Excavator for required bucket size

Refer to Performance Handbook to compare machine models and bucket ranges. Confirm bucket type, size, and maximum material density in Specalog for desired model.

Example:

Required bucket capacity approximately
 4.1 m³ (5.4 yd³)

345B L Series II ME bucket capacity
 to 3.5 m³ (4.6 yd³)

365B L Series II ME bucket capacity
 to 5.3 m³ (6.9 yd³)

385B L ME bucket capacity to 5.6 m³ (7.3 yd³)

Best Choice 365B Series II with 4.0 m³ (5.2 yd³)
 Rock Bucket rated to 1.8 Ton/m³ (3000 lb/yd³)
 material density in Specalog

*Important: Re-calculate Steps 2 - 5 based on cycle times
 of model selected.*

Step 6

Select Haulers

General rule for matching trucks is based on number of cycles to fill the truck.

ME: 4 to 6 passes

Front Shovels: 3 to 5 passes

Example (Metric):

Bucket Selected 4 m³
Volume in 5 passes 5 × 4 × .85 = 17 m³
Payload 17 × 1.6 = 27.2 Tons
Consider weight of Liners 27.2 + 2 = 29.2 Tons

Suitable Truck Match Options:

735 with capacity 19.2 m³/31.8 t
 769D with capacity 24.2 m³/37.9 t

Example (English):

Bucket Selected 5.2 yd³
Volume in 5 passes 5 × 5.2 × .85 = 22.1 yd³
Payload 22.1 × 2700 = 59,670 lb
Consider weight of Liners 59,670 + 4400 lb = 64,070 lb

Suitable Truck Match Options:

735 with capacity 25.1 yd³/70,000 lb
 769D with capacity 31.7 yd³/83,570 lb

EARTHMOVING PRODUCTION

As with any other piece of material handling equipment, excavator earthmoving production is dependent on average bucket payload, average cycle time and job efficiency. If an estimator can accurately predict excavator cycle time and bucket payload, a machine’s earthmoving production can be derived from the following formula.

$$\begin{aligned}
 \text{m}^3 \text{ (yd}^3\text{)}/60 \text{ min hr} &= \text{Cycles}/60 \text{ min hr} \times \text{Avg. Bucket Payload in m}^3 \text{ (yd}^3\text{)} \\
 \text{m}^3 \text{ (yd}^3\text{)}/60 \text{ min hr} &= \\
 \frac{60 \text{ min/hr}}{\text{Cycle Time – min}} &\times \text{Avg. Bucket Payload in m}^3 \text{ (yd}^3\text{)} \\
 \text{Avg. Bucket Payload} &= \text{Heaped Bucket Capacity} \times \text{Bucket Fill Factor} \\
 \text{Actual m}^3 \text{ (yd}^3\text{)}/\text{hr} &= \text{m}^3 \text{ (yd}^3\text{)}/60 \text{ min hr} \times \text{Job Efficiency Factor}
 \end{aligned}$$

The Production Estimating Tables (next page) will provide theoretical earthmoving production in cubic meters (yards) per hour if bucket size and cycle time can be estimated. The use of an average cycle time allows adjusting the estimated production for specific job sites and applications. For instance, estimating truck loading applications should include truck exchange times which extends the average cycle time and reduces production potential. The values in the table are based on a 60 minute work hour or 100% efficiency (a condition that is never achieved in reality). The estimator should apply a job efficiency factor to the figures in the table based on his judgment or knowledge of actual job conditions.

Areas outlined on the Production Estimating Table define the work ranges of excavators in the size classes of Cat 307 through 5230 ME Excavators. The upper limit on each area corresponds to the “fastest practical” cycle time for the machines. The width of each area corresponds to the range of bucket payload sizes the machine can handle. An unshaded box has been provided in each machine area to provide a guide indicating that the upper limit of earthmoving production is being approached. When working beyond the values in the white area, the estimator should be certain that excellent job conditions will be encountered (easy digging, shallow trench, good operator, etc.).

The Production Estimating Table can also serve as a guide when selecting the proper size machine to do a job, as is shown in the following example.

Example problem (Metric)

Contractor has a job to move 15 300 Bm³ (19 100 Lm³ considering 25% swell factor) of wet sandy loam material in rear dump on-highway trucks which will be loaded by an excavator. Average face depth will be 2.4 m with 60-90 degree average swing angle. Ten days are available to do the work. Contractor plans to work 10 hrs/day and estimates a 50 min. work hour (83% job efficiency). He has two excavators that could be made available to do the work — a 320 with 1.0 m³ bucket or a 336 with 1.9 m³ bucket. Experience has shown that either machine can get its rated capacity in the sandy loam soil. Could this job be done with either machine or will the 336 have to be used?

Solution: The excavator must produce 1900 Lm³/ Day (19 100 Lm³ ÷ 10 Days) which means the required average hourly rate will be 190 Lm³/60 Min. Hr. (1900 Lm³/ Day ÷ 10 hrs/day). Further considering the 83% job efficiency, the excavator’s capability will have to be 230 Lm³/ 50 min hr.

The production estimating table shows that the 320 with a 1.0 m³ bucket would have to achieve a 17.1 sec. average cycle time to produce the required 190 Lm³/60 min. hr. With job efficiency applied a 15.0 second average cycle time is required to produce the 230 Lm³/50 min. hr. The 336 with a 1.9 m³ bucket could obtain the same 60 min. hr. production level with a 35 second average cycle, or 30 second cycles to meet the 50 min. hr. production requirement. The cycle times estimating chart shows that the 320 would be working near its maximum capability to meet the production requirement, whereas, the 336 could handle the job easily. This information can then be weighed against what else is known about the job (reach requirements, job conditions, operator ability, etc.) to decide whether or not the larger machine is needed.

Example problem (English)

Substitute these English values in the preceding problem:
Job — 20,000 BCY (25,000 LCY considering 25% swell).
Average face depth — 8-12 ft
320 L with 1.25 yd³ bucket or 336 with 2.5 yd³ bucket.

Solution: The excavator must produce 2500 LCY/ Day, which means the required average hourly rate will be 250 LCY/60 min hr. Further considering the 83% job efficiency the excavator's capability will have to be 300 LCY/50 min hr.

The same concluding comments regarding the Production Estimating Table apply here as in the Metric example.

Cubic Meters per 60 Minute Hour*

ESTIMATED CYCLE TIMES		ESTIMATED BUCKET PAYLOAD** – LOOSE CUBIC METERS																			ESTIMATED CYCLE TIMES		
Cycle Time		0.2	0.3	0.5	0.7	0.9	1.1	1.3	1.5	1.7	1.9	2.1	2.3	2.5	2.7	2.9	3.1	3.3	3.5	4.0	Cycles Per Min.	Cycles Per Hr.	
Seconds	Min.																						
10.0	0.17																					6.0	360
11.0	0.18																					5.5	330
12.0	0.20	60	90	150	210	270																5.0	300
13.3	0.22	54	81	135	189	243	297	351	405	459	513	567	621	675	729	783	837	891	945	1080	4.5	270	
15.0	0.25	48	72	120	168	216	264	312	360	408	456	504	552	600	648	696	744	792	840	960	4.0	240	
17.1	0.29	42	63	105	147	189	231	273	315	357	399	441	483	525	567	609	651	693	735	840	3.5	210	
20.0	0.33	36	54	90	126	162	198	234	270	306	342	378	414	450	486	522	558	544	630	720	3.0	180	
24.0	0.40	30	45	75	105	135	165	195	225	255	285	315	345	375	405	435	465	495	525	600	2.5	150	
30.0	0.50	24	36	60	84	108	132	156	180	204	228	252	276	300	324	348	372	396	420	480	2.0	120	
35.0	0.58	20	31	51	71	92	112	133	153	173	194	214	235	255	275	296	316	337	357	408	1.7	102	
40.0	0.67					81	99	177	135	153	171	189	207	225	243	261	279	297	315	360	1.5	90	
45.0	0.75									133	148	164	179	195	211	226	242	257	273	312	1.3	78	
50.0	0.83																				1.2	72	

Cubic Yards per 60 Minute Hour*

ESTIMATED CYCLE TIMES		ESTIMATED BUCKET PAYLOAD** – LOOSE CUBIC YARDS																			ESTIMATED CYCLE TIMES		
Cycle Time		0.25	0.50	0.75	1.00	1.25	1.50	1.75	2.00	2.25	2.50	2.75	3.00	3.25	3.50	3.75	4.00	4.50	5.00	5.25	Cycles Per Min.	Cycles Per Hr.	
Seconds	Min.																						
10.0	0.17																					6.0	360
11.0	0.18																					5.5	330
12.0	0.20	75	150	225	300	375																5.0	300
13.3	0.22	67	135	202	270	337	404	472	540	607	675	742	810	877	945	1012	1080	1215	1350	1417	4.5	270	
15.0	0.25	60	120	180	240	300	360	420	480	540	600	660	720	780	840	900	960	1080	1200	1260	4.0	240	
17.1	0.29	52	105	157	210	262	315	367	420	472	525	577	630	682	735	787	840	945	1050	1102	3.5	210	
20.0	0.33	45	90	135	180	225	270	315	360	405	450	495	540	585	630	675	720	810	900	945	3.0	180	
24.0	0.40	37	75	112	150	187	225	262	300	337	375	412	450	487	525	562	600	675	750	787	2.5	150	
30.0	0.50	30	60	90	120	150	180	210	240	270	300	330	360	390	420	450	480	510	600	630	2.0	120	
35.0	0.58	36	51	77	102	128	154	180	205	231	256	282	308	333	360	385	410	462	513	535	1.7	102	
40.0	0.67					112	135	157	180	202	225	247	270	292	315	337	360	405	450	472	1.5	90	
45.0	0.75									180	200	220	240	260	280	300	320	360	400	409	1.3	78	
50.0	0.83																				1.2	72	

Job Efficiency Estimator

Work Time/Hour	Efficiency
60 Min	100%
55	91%
50	83%
45	75%
40	67%

*Actual hourly production = (60 min. hr. production) × (Job Efficiency Factor)

**Estimated Bucket Payload = (Amount of Material in the Bucket) × (Bucket Fill Factor)

Unshaded area indicates average production.

Cubic Meters/Yards per 60 Minute Hour*

ESTIMATED CYCLE TIMES		ESTIMATED BUCKET PAYLOAD** — LOOSE CUBIC METERS/YARDS											ESTIMATED CYCLE TIMES	
Cycle Time		5.0	6.0	7.0	8.0	9.0	10.0	11.0	12.0	13.0	14.0	15.0	Cycles Per Min.	Cycles Per Hr.
Seconds	Min.													
15.0	0.25	1200	1440	1680	1920	2160	2400	2640	2880	3120	3360	3600	4.0	240
17.1	0.29	1050	1260	1470	1680	1890	2100	2310	2520	2730	2940	3150	3.5	210
20.0	0.33	900	1080	1260	1440	1620	1800	1980	2160	2340	2520	2700	3.0	180
24.0	0.40	750	900	1050	1200	1350	1500	1650	1800	1950	2100	2250	2.5	150
30.0	0.50	600	720	840	960	1080	1200	1320	1440	1560	1680	1800	2.0	120
35.0	0.58	510	612	714	816	918	1020	1122	1224	1326	1428	1530	1.7	102
40.0	0.67	450	540	630	720	810	900	990	1080	1170	1260	1350	1.5	90
45.0	0.75	390	468	546	624	702	780	858	936	1014	1092	1170	1.3	78
50.0	0.83	360	432	504	576	648	720	792	864	936	1008	1080	1.2	72
55.0	0.92	330	396	462	528	594	660	726	792	858	924	990	1.1	66
60.0	1.00	300	360	420	480	540	600	660	720	780	840	900	1.0	60

Cubic Meters/Yards per 60 Minute Hour*

ESTIMATED CYCLE TIMES		ESTIMATED BUCKET PAYLOAD** — LOOSE CUBIC METERS/YARDS										ESTIMATED CYCLE TIMES	
Cycle Time		16.0	17.0	18.0	19.0	20.0	21.0	22.0	23.0	24.0	25.0	Cycles Per Min.	Cycles Per Hr.
Seconds	Min.												
15.0	0.25	3840	4080	4320	4560	4800	5040	5280	5520	5760	6000	4.0	240
17.1	0.29	3360	3570	3780	3990	4200	4410	4620	4830	5040	5250	3.5	210
20.0	0.33	2880	3060	3240	3420	3600	3780	3960	4140	4320	4500	3.0	180
24.0	0.40	2400	2550	2700	2850	3000	3150	3300	3450	3600	3750	2.5	150
30.0	0.50	1920	2040	2160	2280	2400	2520	2640	2760	2880	3000	2.0	120
35.0	0.58	1632	1734	1836	1938	2040	2142	2244	2346	2448	2550	1.7	102
40.0	0.67	1440	1530	1620	1710	1800	1890	1980	2070	2160	2250	1.5	90
45.0	0.75	1248	1326	1404	1482	1560	1638	1716	1794	1872	1950	1.3	78
50.0	0.83	1152	1224	1296	1368	1440	1512	1584	1656	1728	1800	1.2	72
55.0	0.92	1056	1122	1188	1254	1320	1386	1452	1518	1584	1650	1.1	66
60.0	1.00	960	1020	1080	1140	1200	1260	1320	1380	1440	1500	1.0	60

Job Efficiency Estimator

Work Time/Hour	Efficiency
60 Min	100%
55	91%
50	83%
45	75%
40	67%

*Actual hourly production = (60 min. hr. production) × (Job Efficiency Factor)

**Estimated Bucket Payload = (Amount of Material in the Bucket) × (Bucket Fill Factor)

NOTE: For estimating truck loading production include approximately 0.7 minutes for truck exchange time.

EXCAVATOR TRENCHING PRODUCTION

When an excavator is used for trenching applications, a meaningful expression of work produced is the machine's trenching rate expressed in meters or lineal feet per hour or per day. Trenching rate depends on the earthmoving production of the excavator being used and the size of the trench being excavated. Earthmoving production converts to trenching production as follows:

$$\text{Lineal Meters of Trench per Hour} = \frac{\text{Cubic Meters Excavated per Hour}}{\text{Cubic Meters per Lineal Meter of Trench}}$$

$$\text{Lineal Meters of Trench per Day} = (\text{Lineal Meters per Hour}) \times (\text{Trenching Hours per Day})$$

$$\text{Lineal Feet of Trench per Hour} = \frac{\text{Yd}^3 \text{ Excavated Per Hour}}{\text{Yd}^3 \text{ Per Lineal Foot of Trench}}$$

$$\text{Lineal Feet of Trench Per Day} = (\text{Lineal Ft Per Hour}) \times (\text{Trenching Hours Per Day})$$

For machines that work in trenching applications where they dig all of the time, the *Trenching Conversion Chart* provides easy conversion from m³ (yd³) per hour to m (lineal feet) per hour, if the excavating rate m³/hr (yd³/hr) and trench volume m³/m (yd³/ft) are known. The following examples demonstrate how the Trenching Conversion Chart can be used.

Example problem (Metric)

Contractor estimates that the 329 Excavator will produce 200 Lm³/hour. Trench survey shows that the trench contains 2.5 Lm³/meter. What trenching rate will the 329 produce?

Solution: Enter the horizontal axis of the Trenching Conversion Chart at 200 m³/Hour and move up to the 2.5 m³/m diagonal line. Then move left to the vertical axis of chart and read answer of 80 m/hour.



Example problem 2 (Metric)

Contractor knows he must produce 1000 meters of trench in every 10 hour work day. Survey shows that trench contains 1.5 Bm³ per lineal meter and soil swell factor is estimated at 30%. How much earthmoving production will the excavator have to provide in order to get the job done on time assuming a 50 min work hour? What Cat excavator will provide needed production at 6 meter maximum depth in sandy loam soil?

Solution: Determine trenching requirement 1000 meters in 10 hrs = 100 m/h. Convert Bm³ to Lm³ (excavator handles Lm³) 1.5 Bm³/m × 1.30 = 2.0 Lm³/m. Enter vertical axis of trenching conversion chart at m/h and travel horizontally to diagonal line representing 2.0 m³/m. Next move down to horizontal axis and read answer to 200 Lm³/50 min hr. Convert 200 Lm³/ 50 min hr to Lm³/ 60 min hr = 200 = 241 Lm³/60 min hr.

Production estimating tables in this section show that 241 Lm³/60 min hr is within the capability of a 329 Excavator. Job should then be checked for reach and lifting requirements to make sure that the 329 could handle these aspects of the work.



Example problem (English)

Contractor estimates that a 329 Excavator will produce 250 LCY/Hour. Trench survey shows that the trench contains 2.5 LCY/Foot. What trenching rate will the 329 produce?

Solution: Enter the horizontal axis of the Trenching Conversion Chart at 250 yd³/hr. Then move to the vertical axis of chart and read answer of 100 ft/hr.

The Trenching Conversion Chart can also be used to determine the required excavating rate if the contractor can define his trenching production requirement and the trench volume per lineal foot.



Example problem 2 (English)

Contractor knows he must produce 1000 ft of trench in every 10 hr work day. Survey shows that trench contains 1.6 BCY per lineal ft and soil swell factor is estimated at 25%. How much earthmoving production will excavator have to provide in order to get the job done on time assuming 50 min work hour? What Cat model will provide needed production at 8 ft depth in sandy loam soil?

Solution: Determine trenching requirement —
1000 ft in 10 Hrs. = 100 ft/hr
Convert BCY to LCY — 1.6 BCY/ft × 1.25 =
2.0 LCY/ft

Enter vertical axis of trenching conversion chart at 100 ft/hr and travel over to diagonal line representing 2.0 yd³/ft. Next move down to horizontal axis and read answer of 200 LCY/50 min hr.

Convert 200 LCY/50 min hr to LCY/60 min hr =
 $\frac{200}{0.83} = 241 \text{ LCY/60 min hr}$

Production estimating tables in this section show that 241 LCY/60 min. hr. is within capability of a 329 Excavator. Job should then be checked for reach and lifting requirements to make sure that the 329 could handle these aspects of the work.



TRENCHING CONVERSION CHART — CUBIC METERS (yd³) PER HOUR TO METER (ft) PER HOUR

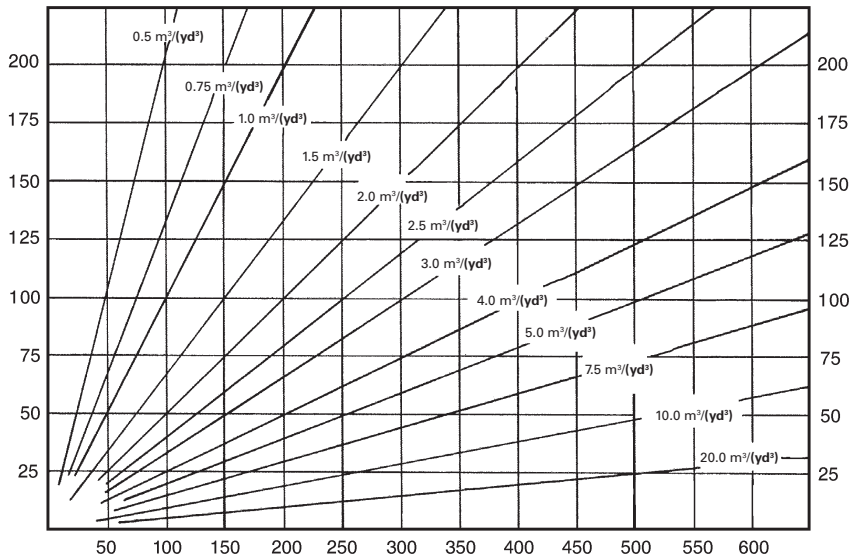

m (ft.) = m³/(yd³) Hr.
Hr. = m³/(yd³) m (ft.)

Values in m³/m or yd³/ft

If excavating rate has been calculated in Bm³/h use Bm³/m for Trench Volume/m.
" " " " " " " " Lm³/h use Lm³/m for Trench Volume/m.
" " " " " " " " BCY/Hr use BCY/ft for Trench Volume/ft.
" " " " " " " " LCY/Hr use LCY/ft for Trench Volume/ft.

Estimating Bucket Size

In addition to the trenching calculations on the previous pages, an alternative method of figuring trenching production is the nomograph. Shown on the following pages, this particular nomograph can be used for estimating bucket size when given trench dimensions and linear production rate. The nomograph is quicker and easier than the preceding example because it does not require as many calculations, yet the accuracy is about the same within the normal limits of input data.

Be careful when entering and reading data from the nomographs because some scales increase from bottom to top, while others are the reverse. Do not be overly concerned with the precision as affected by pencil line width or reading to the hundredth of a m³ (yd³). Remember that bucket fill factor, material density and cycle time are at best close estimates.

Example problem:

A sewer contractor owns a 329 with 2 piece boom and short stick. He wants to bid a contract for a 3.1 m (10') deep trench which measures 1.8 m (6') at the top and 1.2 m (4') at the bottom. He must dig 9 m/hr (30 ft/hr) to finish on time. The material is sand and gravel with a load factor of 0.90 and 100% bucket fill factor. He works 54 minutes per hour, half the time digging and half setting pipe. Cycle time is estimated at 23 seconds which includes a 90° swing angle.

- 1) Enter trench depth 3.1 m (10') on scale A and average trench width 1.5 m (5') on scale B.
- 2) Connect A and B and extend to scale C for bank volume per m (ft).
- 3) Enter estimated load factor (0.90) on scale D.
- 4) Connect C & D and extend to scale E for loose volume per m (ft).

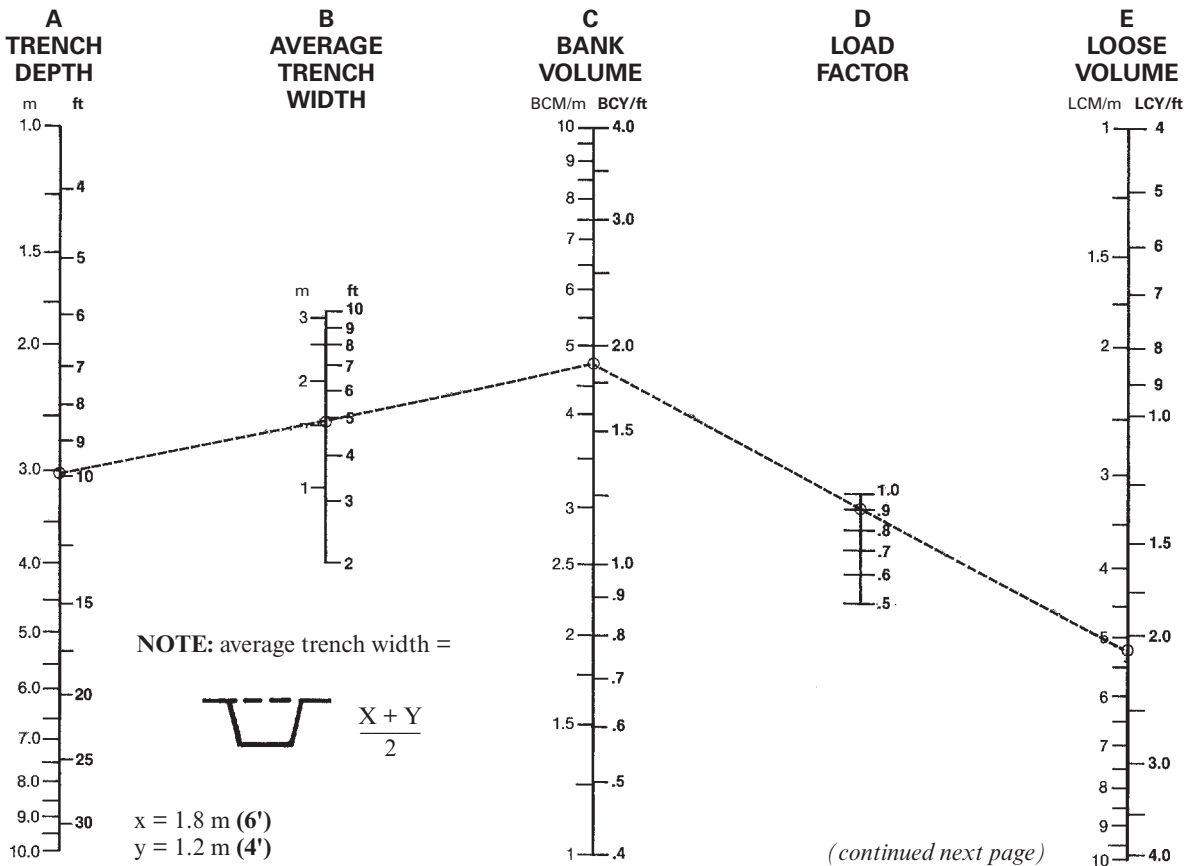

(get loose volume from scale E and enter on this page scale E)

- 5) Enter required linear production rate 9 m/h (30 t/hr) on scale G.
- 6) Connect E and G. Transfer hourly production rate from scale F to scale K (next page).

- 7) Estimate cycle time (23 sec) based on anticipated conditions and enter on scale H.
- 8) Estimate hourly digging time (27 min) and enter on scale I.
- 9) Connect H through I to scale J for cycles per hour.

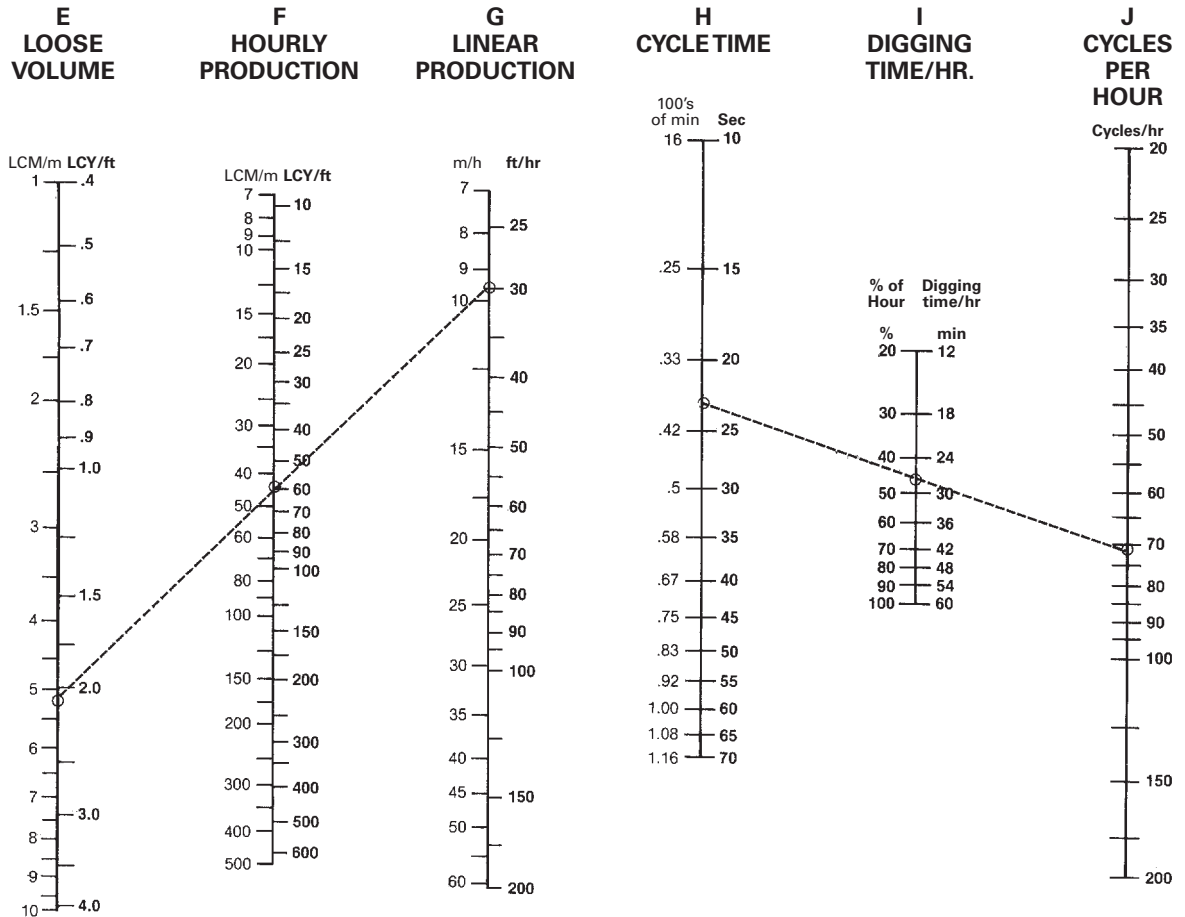

(get cycles per hour from scale J and enter on this page scale J)

- 10) Connect J through K to scale L for required volume per cycle.
- 11) Enter estimated bucket fill factor (100%) on scale M.
- 12) Connect L through M to scale N for required bucket size.

NOTE: Ensure bucket width does not exceed minimum trench width and also that weight of bucket and payload does not exceed machine working weight capacity (see lift capacity charts in this section).

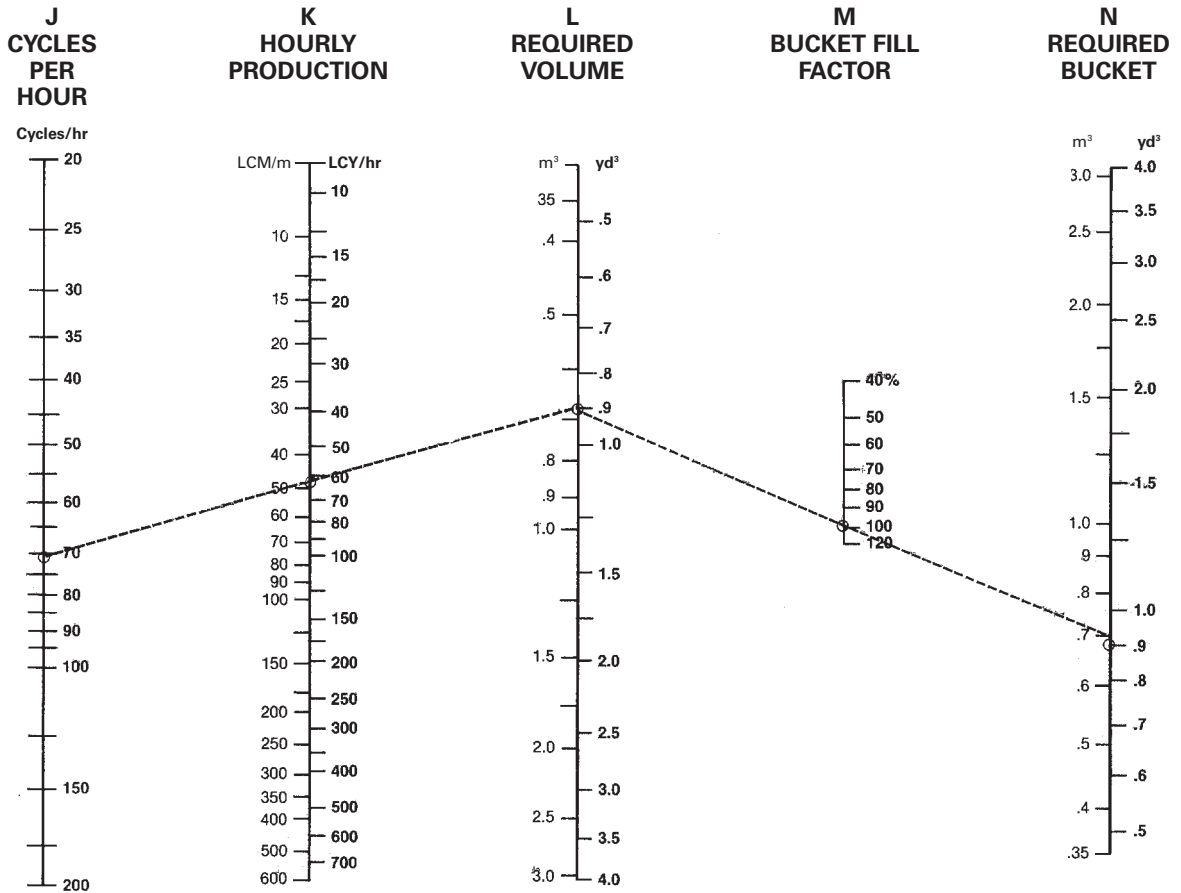

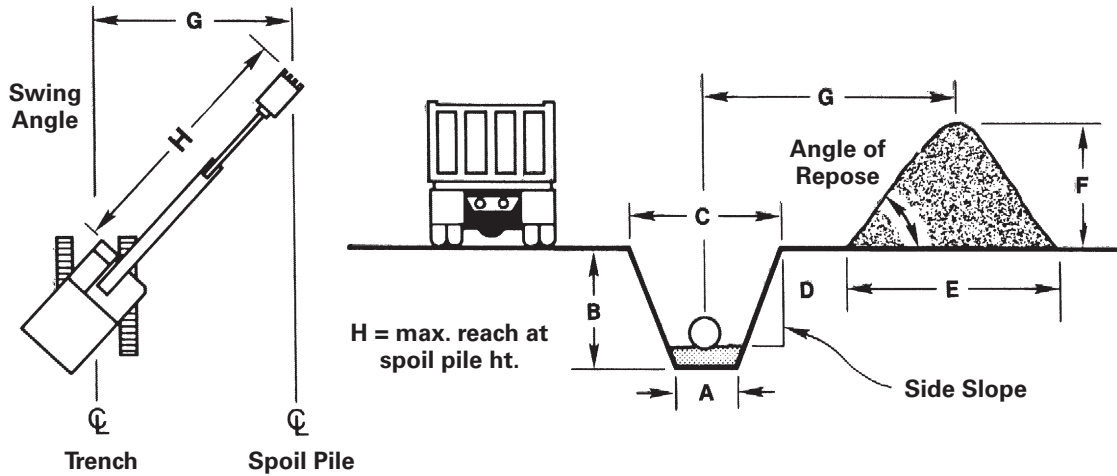

Excavation Volumes Per Meter or Foot of Trench Length

Metric version

Bank $m^3/meter = (\text{Trench end area } m^2) \times (\text{one } m)$
 Trench volume $(Bm^3/m) = \frac{1}{2} (A + C) \times B$
 Spoil pile volume $(Lm^3/m) = (Bm^3/m) \times (1.00 + \% \text{ Swell})$

English version

Bank $yd^3/foot = \frac{(\text{Trench end area } ft^2) \times (\text{one } ft)}{27}$
 Trench volume $(BCY/ft) = \frac{\frac{1}{2} (A + C) \times B}{27}$
 Spoil pile volume $(LCY/ft) = (BCY/ft) \times (1.00 + \% \text{ Swell})$

The following table provides a general guide to trench bottom width for various outside diameters of pipe.

Pipe Diameter		Trench Width		Pipe Diameter		Trench Width	
mm	ft/in	m	ft/in	mm	ft/in	m	ft/in
102	4"	0.49	1'7"	1524	5'0"	2.59	8'6"
152	6"	0.55	1'10"	1676	5'6"	2.80	9'2"
203	8"	0.61	2'0"	1829	6'0"	3.05	10'0"
254	10"	0.70	2'4"	1981	6'6"	3.26	10'8"
305	12"	0.76	2'6"	2134	7'0"	3.47	11'5"
381	15"	0.91	3'0"	2286	7'6"	3.69	12'1"
457	18"	1.03	3'5"	2438	8'0"	3.93	12'11"
533	1'9"	1.16	3'10"	2591	8'6"	4.15	13'7"
610	2'0"	1.25	4'1"	2743	9'0"	4.36	14'4"
686	2'3"	1.37	4'6"	2896	9'6"	4.54	14'11"
838	2'9"	1.58	5'2"	3048	10'0"	4.75	15'7"
914	3'0"	1.70	5'7"	3200	10'6"	4.99	16'5"
1067	3'6"	1.92	6'4"	3353	11'0"	5.21	17'1"
1219	4'0"	2.13	7'0"	3505	11'6"	5.43	17'10"
1372	4'6"	2.38	7'10"	3658	12'0"	5.64	18'6"

NOTE: Trench widths based on $1.25 B_c + 1.0$ where B_c is the outside diameter of the pipe in feet.
 Table courtesy of American Concrete Pipe Association

- Trenching Rate With Pipesetting
- Pipesetting Example Problem

Trenching Production with Pipesetting

On many sewer construction jobs the excavator does more than just dig the trench. Other tasks include handling the shoring system, placing bedding material, and lowering the pipe. The normal work procedure is to open a section of trench and then stop and make a pipe installation before going on to dig the next section of trench. At that point the key to trenching production is the total amount of time required to install each section of pipe. Pipe installation time can be broken down as follows:

Digging time + other time = Total pipe installation time

Total Pipe Installation Time	Pipe Installed Per Hour
60 min	1 Pipe/hr
30 min	2 Pipe/hr
15 min	4 Pipe/hr
10 min	6 Pipe/hr

Digging Time can be calculated once the trenching rate has been calculated using the methods described earlier in this section. Once Digging Time has been calculated, it can be added to an estimate of “Other Time” to determine Total Pipe Installation Time. “Other Time” can be estimated based on a contractor’s judgment, experience, or actual measurement on a job. The following formula and table relate the trenching rate of the excavator to the time required to open a section of trench for pipe of various lengths.

$$\text{Digging Time (Min.)} = \frac{\text{Pipe Length (ft)}}{\text{Trenching Rate (ft/hr)}} \times 60 \text{ (Min/hr)}$$

Trenching Rate Ft. Per Hour	Time Required to Dig for Pipe of Various Lengths							
	8 ft Pipe		12 ft Pipe		16 ft Pipe		20 ft Pipe	
	Hours	Min.	Hours	Min.	Hours	Min.	Hours	Min.
20 ft/hr	0.400	24.00	0.600	36.00	0.800	48.00	1.000	60.00
40	0.200	12.00	0.300	18.00	0.400	24.00	0.500	30.00
60	0.130	8.00	0.200	12.00	0.260	16.00	0.333	20.00
80	0.100	6.00	0.150	9.00	0.200	12.00	0.250	15.00
100	0.080	4.80	0.120	7.20	0.160	9.60	0.200	12.00
120	0.060	4.00	0.100	6.00	0.120	7.20	0.167	10.00
140	0.057	3.43	0.086	5.14	0.114	6.86	0.143	8.57
160	0.050	3.00	0.075	4.50	0.100	6.00	0.125	7.50
180	0.044	2.66	0.067	4.00	0.089	5.33	0.111	6.67
200	0.040	2.40	0.060	3.60	0.080	4.80	0.100	6.00

This table can be used to show how an excavator that is capable of more trenching production will provide significant advantages even on jobs where the machine does not dig all of the time. Consider 12,000' job with

12' sections of pipe (1000 pipe to be installed). Excavator “A” can work at 60 ft/hr while Excavator “B” is capable of producing 120 ft/hr. Table shows that Excavator “B” will only take 0.10 hr to do the same work. This means that over the course of installing the 1000 pipe the more productive machine will save 0.10 hr/pipe or 100 hours of working time.

Example problem (English)

The following example shows how trenching production can be calculated on a job where the excavator is also required to set pipe. This example is based on the assumption that the excavator’s earthmoving rate and the pipe installation time have already been estimated by the contractor.

Problem: Contractor estimates that the 350 Excavator will be able to produce 500 LCY/60 min. hr. Survey shows that an average cross section trench contains 3.2 BCY/ft and swell factor for sandy clay soil is estimated at 25%. How much trenching production can a contractor expect; assuming it takes 10.0 min. to install each 20 ft length of pipe after trench has been opened. Also assume 83% job efficiency — 50 min. work hour and 8 work hours out of a 9 hour shift. (0.5 hours for lunch and two 15 minute breaks.)

Solution:

Convert trench volume to LCY/ft:

$$1.25 (3.2 \text{ BCY/ft}) = 4.0 \text{ LCY/ft}$$

Convert Earthmoving rate to Trenching rate:

$$\frac{500 \text{ LCY/hr}}{4.0 \text{ LCY/ft}} = 125 \text{ ft/hr}$$

Calculate digging time for each pipe:

$$\frac{20 \text{ ft/pipe}}{125 \text{ ft/hr}} = 0.16 \text{ hr/pipe} = 9.6 \text{ min}$$

Calculate pipe installation time:

$$\text{Digging time} = 9.6 \text{ min}$$

$$\text{Other time} = 10.0 \text{ min}$$

$$\text{Pipe Installation time} = 19.6 \text{ min}$$

Calculate pipe installations/hour:

$$\frac{60 \text{ min/hr}}{19.6 \text{ min/pipe}} = 3.06 \text{ pipe/hr}$$

Calculate max. pipe installations/day:

$$8 \text{ hrs} (3.06 \text{ pipe/hr}) = 24.48 \text{ pipe/day}$$

Actual pipe/day:

$$0.83 (24.48 \text{ pipe/day}) = 20.3 - 20 \text{ pipe/day}$$

Actual feet/day:

$$(20 \text{ pipe/day}) \times (20 \text{ ft/pipe}) = 400 \text{ ft/day}$$

HYDROMECHANICAL ATTACHMENTS

CONTENTS

HYDRAULIC HAMMERS

Features	
H25D	8-2
H35E s-H65E s	8-2
H75E s-H95E s	8-2
H110E s-H180E s	8-3
Tool Selection Guide	
Small Hammer Tools	8-4
Large Hammer Tools	8-5
Specifications	8-6
Selection	8-7
Cat® Carrier Matching Guide	8-8
Productivity	8-12

MOBILE SCRAP AND DEMOLITION SHEARS

Applications	8-15
Guarding Recommendation	8-15
Shearing Capability Table	8-16
Specifications	8-17
Matching Guide	8-19

MULTI-PROCESSORS

Features	8-21
Applications	8-21
Matching Guide	8-21
Jaw Types	8-21
Guarding Recommendation	8-22
Specifications	8-22
Cutting Capacity	8-30

CONTRACTOR'S GRAPPLES

Features	8-31
Applications	8-31
Guarding Recommendation	8-31
Matching Guide	8-31
Specifications	8-32

DEMOLITION AND SORTING GRAPPLES

Features	8-33
Matching Guide	8-33
Specifications	8-34

ORANGE PEEL GRAPPLES

North America Version	
Features	8-39
Specifications	8-39
Matching Guide	8-41
Guarding Recommendation	8-41
Europe, Africa, Middle East Version	
Features	8-42
Selection Guide	8-42
Specifications	8-43
Matching Guide	8-47

MULTI-FUNCTIONAL CONCRETE CRUSHERS

Features	8-48
Guarding Recommendation	8-48
Matching Guide	8-48
Specifications and Dimensions	8-49

SECONDARY PULVERIZERS

Features	8-50
Guarding Recommendation	8-50
Matching Guide	8-50
Specifications and Dimensions	8-51

BREAKERS

Specifications	8-52
----------------	------

AUTO-CONNECT QUICK COUPLER

Machine Compatibility	8-54
-----------------------	------

HYDRO MECHANICAL TOOLS FOR COMPACT EQUIPMENT

Please reference the Skid Steer Loaders/Multi Terrain Loaders/Compact Track Loaders section for the following hydro mechanical tools:

- Augers
- Backhoes
- Brooms
- Brushcutters
- Cold Planers
- Vibratory Compactors
- Mulchers
- Landscape Rakes
- Power Box Rakes
- Wheel Saws
- Snow Blowers
- Stump Grinders
- Landscape Tillers
- Trenchers

HYDRAULIC HAMMERS

H25D Hammer Features:

- **Streamlined Shape** fits into narrow places.
- **Simple Design** has only two moving parts for minimal maintenance.
- **High Blow Rate** translates to high productivity.
- **Lower Tool Bushing** can be replaced in minutes in the field.

H35E s-H65E s Hammer Features:

- **Available** in both side plate and silenced versions.
- **Mounting Options** include integral pin-on and flat-top.
- **Gas-fired Operating Cycle** delivers consistent, reliable performance over time.
- **Auto Shut Off (ASO)** — Instantly stops the piston when breaking through material. Prevents blank firing, which is a top cause of hammer wear.
- **Plug and Perform** — No adjustment to pressures or flows is needed.
- **Dual Ports** optimize hose runs on HEX, BHL and SSL/MTL machines.
- **One-piece Body** reduces components, eliminates tie rods and nuts.
- **Single Bushing** design is slip fit and field-replaceable.
- **Tri-suspension System** guides the power cell and gives manageable, smooth performance.
- **Grease Point** is ergonomically located at standing height.
- **Cylinder Sleeve** provides replaceable protection for the cylinder, and drastically cuts labor for rebuilds.
- **Designed to Be Easily Rebuilt**, providing lasting value for your hammer investment.

H75E s-H95E s Hammer Features:

- **Silencing** is standard on all H75E s and H95E s hammers.
- **Tri-suspension System** buffers the power cell, reducing noise and vibration.
- **Integral Accumulator** dampens pressure peaks and pulsation, thus protecting carrier hydraulic system.
- **Gas-fired Operating Cycle** delivers consistent, reliable performance over time.
- **Automatic Shut-off** protects the hammer from blank firing and reduces internal wear, protecting the hammer from less experienced operators.
- **Fully Enclosed Housing** protects the power cell, and is designed to eliminate stress points.
- **Gas Seal System** assures constant power is maintained between service intervals.
- **Single Grease Point** provides hammer paste to tool bushings. Grease point is ergonomically located at standing height making it comfortable for the operator to access.
- **Tool Changes** are simple: easily accomplished with common hand tools. Lower tool bushing can be serviced in the field.
- **Slip Fit Lower Tool Bushing** provides positive tool alignment, is field replaceable and rotatable.
- **Easy to Maintain** — Gas charges can be checked and filled with the hammer mounted on the machine.
- **Designed to Be Easily Rebuilt**, providing lasting value for your hammer investment.

H110E s-H180E s Hammer Features:

- **Unique Suspension System** — Improved recoil, support and guidance protects the carrier, increases hammer durability. Entire power cell is secured firmly inside housing. Noise suppression, operator feel and control is improved.
- **Auto Shut Off (ASO)** — Instantly stops the piston when breaking through material. Prevents blank firing, which is a top cause of hammer wear. Reducing wear improves maintenance and more productive hours of work.
- **Accumulator** — Self-contained membrane accumulator designed for long life. Port is accessible while hammer is mounted on the machine making testing and recharging a routine task achievable in the field.
- **Hydraulic Valves** — A Pressure Control Valve (PCV) maintains maximum hydraulic pressure to ensure the hammer delivers all blows at full power. PCV can be easily checked and adjusted from outside the hammer in about 30 minutes. A check valve (not shown) isolates harmful pulsation spikes from the carrier hydraulic circuit.
- **Autolube Connection and Grease Channel** — Provides grease to the upper and lower tool bushings to ensure proper greasing, longer life for bushings and tool.
- **Seal Carrier** — Contains special high performance seals to extend leak-proof operation.
- **Piston** — Long piston transfers a long shock wave into the rock. Tool-piston diameters are matched for maximum energy transfer.
- **Tie-Rods** — Larger threads improve load carrying capability, durability and reliability.
- **Cylinder** — Engineered to be durable and reliable with minimal maintenance and downtime.
- **Upper Tool Bushing** — Guides the tool to optimize in-line piston to tool contact.
- **Tool Retaining Pins and Keepers** — Tool removal process is simplified, achievable with common hand tools. Removal time reduced by 40% over previous models.
- **Lower Tool Bushing** — As bushing reaches the wear limit, it can be easily rotated (90°) or replaced to bring it back into specification. Dust seals keep contaminants out.

NOTE: Internal components of hammers are machined to close tolerances and require clean oil with full lubricating properties. When operating in high ambient temperatures or extreme temperature applications (e.g. foundries), higher viscosities are recommended to extend hammer life and improve performance. Hammers tend to shear multigrade mineral oil so that oil viscosity decreases. Contamination, water in oil, and decreased viscosity lead to earlier oil deterioration and the need for more frequent oil changes than normally recommended for the excavator. Extra care should be taken to avoid the entry of dust or dirt when installing or removing a hammer in the field.

Small Hammer Tools

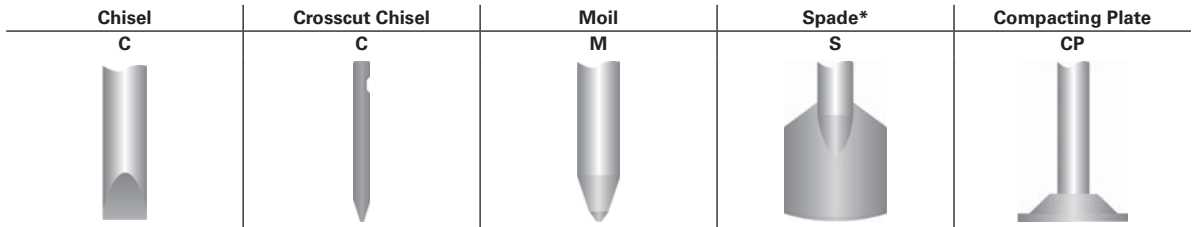

	H25D	H35E/Es	H45E/Es	H55E/Es	H65E/Es	H75 s	H95 s
Road building/construction							
Breaking of road surface	C, M	C, M, S	C, M, S	C, M, S	C, M, S	C, M, S	C, M
Asphalt cutting	C	C, S	C, S	C, S	C, S	C, S	C
Trench excavation for drainage						C, M	C, M
Demolition of bridges	C, M	C, M	C, M	C, M	C, M	C, M	C, M
Compacting soils		CP	CP	CP	CP	CP	
Making holes (for traffic signs, lamp posts)		M	M	M	M	M	M
Breaking of frozen ground	C, M	C, M, S	C, M, S	C, M, S	C, M, S	C, M, S	C, M
Demolition/housing development							
Demolition of concrete walls, roofs, floors	C, M	C, M	C, M	C, M	C, M	C, M	C, M
Demolition of light, reinforced concrete [<0.5 m (<20")]	M	M	M	M	M	M	M
Brick walls	C, M	C, M	C, M	C, M	C, M	C, M	C, M
Rock trenches for mains/water supply/utilities						C, M	C, M
Rock excavation for foundation							C, M
Separating rebar from concrete (for recycling)	C, M	C, M	C, M	C, M	C, M	C, M	C, M
Quarrying/open cast mining							
Breaking over sizes on a crusher/feeder/feed chute							C, M
Scaling						C	C
Metallurgical applications							
Breaking of slag in casting ladles							C, M
Cleaning of castings							C, M
Breaking of refractory linings in furnaces	C, M	C, M	C, M	C, M	C, M	C, M	C, M

*Spade available as parallel (parallel with the boom) and transverse (perpendicular to the boom).

Large Hammer Tools

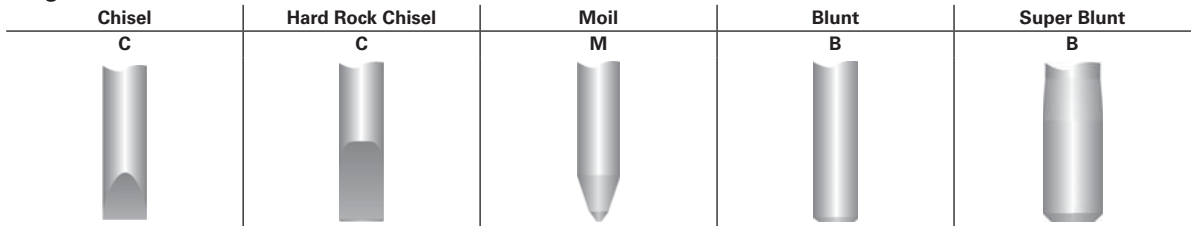

	H110E s	H115E s	H120E s	H130E s	H140E s	H160E s	H180E s
Road building/construction							
Breaking of road surface	C, M	C, M	C, M	C, M	C, M	C, M	C, M
Breaking uneven bedrock to lay a road	C, M	C, M	C, M	C, M	C, M	C, M	C, M
Primary breaking to prepare road bed					C, M	C, M	C, M
Trench excavation for drainage	C, M	C, M	C, M	C, M	C, M	C, M	C, M
Demolition of bridges	C, M	B, C, M	B, C, M	B, C, M	B, C, M	B, C, M	B, C, M
Heavily reinforced bridge pillars					B	B	B
Making holes (for traffic signs, lamp posts)	M	M	M	M	M	M	M
Breaking of frozen ground	C, M	C, M	C, M	C, M	C, M	C, M	C, M
Demolition/housing development							
Demolition of concrete walls, roofs, floors	C, M	B, C, M	B, C, M	B, C, M	B, C, M	B, C, M	B, C, M
Demolition of light, reinforced concrete [<0.5 m (<20")]	M	B, M	B, M	B, M			
Brick walls	C, M	B, C, M	B, C, M	B, C, M	B, C, M	B, C, M	B, C, M
Rock trenches for mains/water supply/utilities	C, M	C, M	C, M	C, M	C, M	C, M	C, M
Rock excavation for foundation	C, M	C, M	C, M	C, M	C, M	C, M	C, M
Mass excavation of rock for industrial building bases				C, M	C, M	C, M	C, M
Massive reinforced concrete foundations					M	M	M
Separating rebar from concrete (for recycling)	C, M	B, C, M	B, C, M	B, C, M	B, C, M	B, C, M	B, C, M
Quarrying/open cast mining							
Secondary boulder breaking	B	B	B	B	B	B	B
Primary breaking of rock				C, M	C, M	C, M	C, M
Breaking over sizes on a crusher/feeder/feed chute	C, M	B, C, M	B, C, M	B, C, M	B, C, M	B, C, M	
Underground applications							
Scaling	C	C					
Metallurgical applications							
Breaking of slag in casting ladles	C, M	C, M					
Breaking of slag in converter openings	C, M	C, M	C, M	C, M	C, M		
Cleaning of castings	C, M	C, M					
Breaking of massive steel slag						C, M	C, M
Breaking of aluminum electrolyze slag	C, M	C, M	C, M	C, M	C, M		
Other applications							
Demolition/rock breaking under water		C, M	C, M	C, M	C, M	C, M	C, M

Model	H25D		H35E/H35E s		H45E/H45E s		H55E/H55E s	
Working weight ¹	70 kg	154 lb	125-130 kg	276-287 lb	145-250 kg	276-287 lb	220-345 kg	485-761 lb
Impact frequency ²	1000-1900 bpm		600-1800 bpm		780-1800 bpm		600-1680 bpm	
Hammer operating pressure ³	12 000 kPa	1740 psi	16 500 kPa	2393 psi	16 500 kPa	2393 psi	17 000 kPa	2465 psi
Acceptable oil flow	15-25 L/min	4-6.6 gpm	12-35 L/min	3-9 gpm	25-62 L/min	6.6-16 gpm	30-85 L/min	7.9-22 gpm
Carrier weight class	0.8-1.1 t	1764-2430 lb	1.1-2.4 t	2430-5300 lb	1.5-3.2 t	3310-7060 lb	2.5-6.0 t	5500-13,200 lb

Model	H65E/H65E s		H75E s		H95E s		H110E s	
Working weight ¹	260-390 kg	573-860 lb	500 kg	1103 lb	627 kg	1382 lb	830 kg-1017 kg	1826 lb-2237 lb
Impact frequency ²	720-1740 bpm		840-1650 bpm		700-1260 bpm		450-1000 bpm	
Hammer operating pressure ³	17 000 kPa	2465 psi	14 500 kPa	2100 psi	14 500 kPa	2100 psi	16 000 kPa	2320 psi
Acceptable oil flow	40-115 L/min	10-30 gpm	70-130 L/min	18-34 gpm	70-150 L/min	18-40 gpm	60-120 L/min	16-32 gpm
Carrier weight class	3-9 t	6600-19,800 lb	6-10 t	13,200-22,100 lb	7-14 t	15,400-30,900 lb	7-16 t	17,600-35,200 lb

Model	H115E s		H120E s		H130E s	
Working weight ¹	1000-1180 kg	2200-2596 lb	1300-1580 kg	2860-3476 lb	1700-1890 kg	3740-4158 lb
Impact frequency ²	370-800 bpm		350-620 bpm		320-600 bpm	
Hammer operating pressure ³	15 000 kPa	2175 psi	15 000 kPa	2175 psi	15 000 kPa	2175 psi
Acceptable oil flow	70-130 L/min	18-34 gpm	100-170 L/min	26-45 gpm	120-220 L/min	32-58 gpm
Carrier weight class	12-20 t	26,400-44,000 lb	17-26 t	37,400-57,200 lb	19-32 t	41,800-70,400 lb

Model	H140E s		H160E s		H180E s	
Working weight ¹	2475 kg	5457 lb	3337 kg	7358 lb	4251 kg	9373 lb
Impact frequency ²	360-505 bpm		380-560 bpm		270-410 bpm	
Hammer operating pressure ³	16 000 kPa	2320 psi	16 000 kPa	2320 psi	16 000 kPa	2320 psi
Acceptable oil flow	160-230 L/min	42-60 gpm	220-300 L/min	58-79 gpm	220-300 L/min	58-79 gpm
Carrier weight class	24-42 t	52,920-92,610 lb	32-55 t	70,560-121,275 lb	42-76 t	92,610-167,580 lb

¹ Includes power cell, side plates/housing, average mounting bracket, where required, and standard tool.

² Approximate value, actual impact frequency depends on oil flow, oil viscosity, temperature, and hardness of material to be broken.

³ Approximate value, operating pressure depends on oil flow, oil viscosity, temperature, material to be broken, and back pressure. Operating pressure is the result of correct low pressure adjustment.

Oil temperature working range for all models: -20° C to +80° C (-4° F to +176° F).

Oil viscosity at operating oil temperature: 15 to 1000 cSt.

Principles of Selection

Key to the successful sale of a hammer is proper hammer selection.

Background Information

Collection of background information is the first step. The following information will assist in being sure the customer receives the correct hammer and that he has a positive hammer experience. The following issues should be examined...

1. If any, what brand and model hammer was previously used and how did the hammer perform?
2. What % of time will the hammer be used on the machine?
3. Will the hammer be used in primary breaking or secondary breaking? (mainly an issue for large hammers)
4. What machine will the hammer be used on and what are the hydraulic flow and pressures of this machine?
5. What is the type of material to be broken and production required from the hammer? (best to obtain this from the end user but a table is available at the end of this section)

Hammer Selection Process

1. Using Cat carrier matching matrix on next page identify 2 or 3 possible hammers for your application (for competitive carriers use carrier weight class as reference).
2. Compare machine/carrier flow and pressures to those of the hammer candidates to validate compatibility. Eliminate hammers outside carrier specs.
3. If hammer is to be used in primary breaking consider larger of hammer candidates.
4. Check productivity guidance tables at the back of this section. Identify hammer most compatible with requirements.
5. Determine if the application requires special hammer modifications, i.e. steel mill, underwater, tunneling, etc.

Other Issues

Once the hammer has been chosen, other elements need to be considered to have a successful hammer experience.

1. Select the correct hammer tool for the application (see tool application chart in this section).
2. Check to be sure the correct hammer bracket and hoses are specified. Be sure correct carrier oil is specified for hammer use (particularly important in high ambient areas).
3. Consider supplemental carrier cooling in areas of high ambient temperature.

Actual operating pressure and back pressure **MUST** be checked when the hammer is fitted to the carrier (just as important if the hammer goes on a competitive carrier or is installed by the contractor at his shop).

Guarding Recommendation

Hammers used in hazardous applications like demolition, quarrying, and scaling, can create a need for special operator guarding due to flying objects. When using a hammer, additional protective devices such as a front screen, Falling Object Guarding System (FOGS, includes top and front guarding), thick polycarbonate windshields or a combination of these is recommended by Caterpillar. Contact your Cat dealer for operator guarding options on your machine.

		H25D	H35E H35E s	H45E H45E s	H55E Pin-on	H55E H55E s Flat Top	H65E Pin-on	H65E H65E s Flat Top	H75E s
Carrier weight									
Minimum	mt	0.8	1.1	1.5	2.5	2.5	3.0	3.0	6.0
	lb	1760	2430	3310	5500	5500	6610	6610	13,200
Maximum	mt	1.1	2.4	3.2	6.0	6.0	9.0	9.0	10.0
	lb	2430	5300	7060	13,200	13,200	19,800	19,800	22,100
Excavators									
300.9D		•							
301.4C			•						
301.7D CR			•	•					
301.8C			•	•					
302.2D			•	•					
302.4D			•	•					
302.5C				•	•	•*			
302.7D CR				•	•	•*			
303.5D CR/303.5E CR					•	•	•		
304D CR/304E CR					•	•	•		
305D CR/305E CR					•	•	•	•	
305.5D CR/305.5E CR					•	•	•	•	
307D								•**	•
308D CR/308E CR SB/308E2 CR SB								•**	•
311D RR									
312D/312D L/312E/312E L									
314D CR/314E CR									
315D									
316E									
318E									
319D									
320D/320E									
320D RR/320E RR									
321D LCR									
324D									
324E									
328D LCR									
329D/329E									
336D/336E/336EH									
345D									
349E									
365C									
374D									

*Installation of add-on optional counterweight to machine is required.

**Hydraulic flows and pressures must be checked to verify they match the requirements for the hammer being installed.

NOTE: Caterpillar recommends the use of a suitable shield/guard system to insure operator has adequate protection from flying debris.

NOTE: These matches are for general reference purposes for Cat machines only. When special boom and quick coupler arrangements are used, these matches may not apply.

NOTE: When matching hammers to competitive carriers, selection should be made by carrier weight. Refer to the carrier range at the top of the table in order to determine the correct match.

		H95E s	H110E s	H115E s	H120E s	H130E s	H140E s	H160E s	H180E s
Carrier weight									
Minimum	mt	7.0	11.0	12.0	16.0	18.0	24.0	32.0	42.0
	lb	15,400	24,300	26,500	35,300	39,700	52,920	70,600	92,600
Maximum	mt	14.0	18.0	20.0	27.0	36.0	42.0	55.0	76.0
	lb	30,900	39,700	44,100	59,500	79,400	92,600	121,300	167,600
Excavators									
300.9D									
301.4C									
301.7D CR									
301.8C									
302.2D									
302.4D									
302.5C									
302.7D CR									
303.5D CR/303.5E CR									
304D CR/304E CR									
305D CR/305E CR									
305.5D CR/305.5E CR									
307D		•							
308D CR/308E CR SB/308E2 CR SB		•							
311D RR		•	•						
312D/312D L/312E/312E L		•	•	•					
314D CR/314E CR			•	•					
315D			•	•	•				
316E			•	•	•				
318E				•	•	•			
319D				•	•	•			
320D/320E				•	•	•			
320D RR/320E RR				•	•	•			
321D LCR					•	•			
324D					•	•	•		
324E					•	•	•		
328D LCR						•	•		
329D/329E					•	•	•		
336D/336E/336EH							•	•	
345D								•	•
349E								•	•
365C									•
374D									•

*Installation of add-on optional counterweight to machine is required.

**Hydraulic flows and pressures must be checked to verify they match the requirements for the hammer being installed.

NOTE: Caterpillar recommends the use of a suitable shield/guard system to insure operator has adequate protection from flying debris.

NOTE: These matches are for general reference purposes for Cat machines only. When special boom and quick coupler arrangements are used, these matches may not apply.

NOTE: When matching hammers to competitive carriers, selection should be made by carrier weight. Refer to the carrier range at the top of the table in order to determine the correct match.

		H25D	H35E H35E s	H45E H45E s	H55E Pin-on	H55E H55E s Flat Top	H65E Pin-on	H65E H65E s Flat Top	H75E s
Carrier weight									
Minimum	mt	0.8	1.1	1.5	2.5	2.5	3.0	3.0	6.0
	lb	1760	2430	3310	5500	5500	6610	6610	13,200
Maximum	mt	1.1	2.4	3.2	6.0	6.0	9.0	9.0	10.0
	lb	2430	5300	7060	13,200	13,200	19,800	19,800	22,100
Wheeled Excavators									
M313C/M313D									
M315C/M315D									
M316C/M316D									
M318C/M318D									
M322C/M322D									
Skid Steer and Multi-Terrain Loaders									
216B2/216B3					•	•	•	•	
226B2/226B3					•	•	•	•	
236B3/236D					•	•	•	•	
242B3/242D					•	•	•	•	
246C/246D					•	•	•	•	
247B2/247B3					•	•	•	•	
252B2/252B3					•	•	•	•	
257B3/257D					•	•	•	•	
259B3/259D					•	•	•	•	
262C2/262D					•	•	•	•	
272D/272D XHP					•	•	•	•	
277C2/277D					•	•	•	•	
279C2/279D					•	•	•	•	
287C2/287D					•	•	•	•	
289C2/289D					•	•	•	•	
297C					•	•	•	•	
299C/299D/299D XHP					•	•	•	•	
Backhoes									
BH30/BH30W					•	•			
BH150/BH160					•	•	•		
Backhoe Loaders									
416E/416F								•**	•
420E/420F								•**	•
430E/430F								•**	•
446D									
450E/450F									

*Installation of add-on optional counterweight to machine is required.

**Hydraulic flows and pressures must be checked to verify they match the requirements for the hammer being installed.

NOTE: Caterpillar recommends the use of a suitable shield/guard system to insure operator has adequate protection from flying debris.

NOTE: These matches are for general reference purposes for Cat machines only. When special boom and quick coupler arrangements are used, these matches may not apply.

NOTE: When matching hammers to competitive carriers, selection should be made by carrier weight. Refer to the carrier range at the top of the table in order to determine the correct match.

		H95E s	H110E s	H115E s	H120E s	H130E s	H140E s	H160E s	H180E s
Carrier weight									
Minimum	mt	7.0	11.0	12.0	16.0	18.0	24.0	32.0	42.0
	lb	15,400	24,300	26,500	35,300	39,700	52,920	70,600	92,600
Maximum	mt	14.0	18.0	20.0	27.0	36.0	42.0	55.0	76.0
	lb	30,900	39,700	44,100	59,500	79,400	92,600	121,300	167,600
Wheeled Excavators									
M313C/M313D			•	•					
M315C/M315D			•	•	•				
M316C/M316D			•	•	•				
M318C/M318D				•	•	•			
M322C/M322D				•	•	•			
Skid Steer and Multi-Terrain Loaders									
216B2/216B3									
226B2/226B3									
236B3/236D									
242B3/242D									
246C/246D									
247B2/247B3									
252B2/252B3									
257B3/257D									
259B3/259D									
262C2/262D									
272D/272D XHP									
277C2/277D									
279C2/279D									
287C2/287D									
289C2/289D									
297C									
299C/299D/299D XHP									
Backhoes									
BH30/BH30W									
BH150/BH160									
Backhoe Loaders									
416E/416F		•							
420E/420F		•							
430E/430F		•							
446D		•	•						
450E/450F		•	•						

*Installation of add-on optional counterweight to machine is required.

**Hydraulic flows and pressures must be checked to verify they match the requirements for the hammer being installed.

NOTE: Caterpillar recommends the use of a suitable shield/guard system to insure operator has adequate protection from flying debris.

NOTE: These matches are for general reference purposes for Cat machines only. When special boom and quick coupler arrangements are used, these matches may not apply.

NOTE: When matching hammers to competitive carriers, selection should be made by carrier weight. Refer to the carrier range at the top of the table in order to determine the correct match.

Productivity Rates: 8 hour shift

Production rates listed are for general estimation purposes only and must not be used to guarantee any production figure to the customer. The actual working results may vary according to the quality and structure of the material to be broken, required degree of material size reduction, installation, condition of the carrier, conditions at the work site, haulage of the broken material, skills of the operator, etc.

Hammer Models	Non-Reinforced Concrete		Reinforced Concrete		Sedimentary Rock		Volcanic Rock	
H35E/E s	6-12 m ³	8-16 yd³						
H45E/E s	8-18 m ³	10-23 yd³						
H55E/E s	14-23 m ³	18-30 yd³						
H65E/E s	45-90 m ³	34-69 yd³						
H75E s	65-107 m ³	85-140 yd³	19-46 m ³	25-60 yd³				
H95E s	69-122 m ³	90-160 yd³	38-61 m ³	50-80 yd³				
H110E s	99-214 m ³	130-280 yd³	96-134 m ³	125-175 yd³	84-121 m ³	110-250 yd³	42-99 m ³	55-130 yd³
H115E s	115-287 m ³	150-375 yd³	107-184 m ³	140-240 yd³	126-229 m ³	165-300 yd³	57-115 m ³	75-150 yd³
H120E s	153-344 m ³	200-450 yd³	122-229 m ³	160-300 yd³	153-260 m ³	200-340 yd³	84-153 m ³	110-200 yd³
H130E s	210-375 m ³	275-490 yd³	153-268 m ³	200-350 yd³	191-306 m ³	250-400 yd³	103-210 m ³	135-210 yd³
H140E s			191-497 m ³	250-650 yd³	229-535 m ³	300-700 yd³	115-268 m ³	150-350 yd³
H160E s			229-650 m ³	300-850 yd³	268-688 m ³	350-900 yd³	153-459 m ³	200-600 yd³
H180E s			295-1301 m ³	385-1705 yd³	337-1345 m ³	440-1760 yd³	210-757 m ³	275-990 yd³

The figures are for comparison and evaluation purposes only. Results will vary depending on operator, carrier and job conditions.

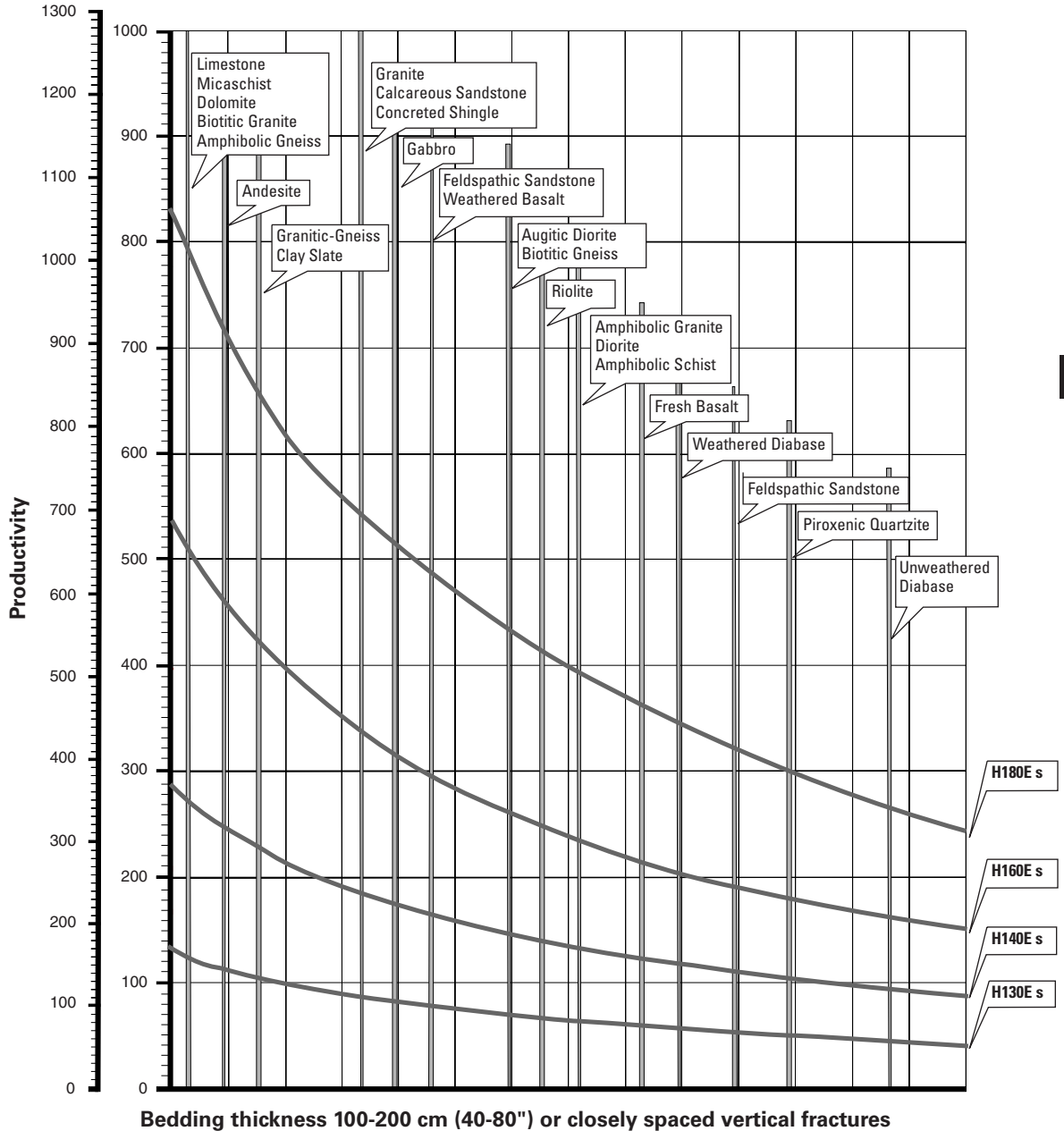

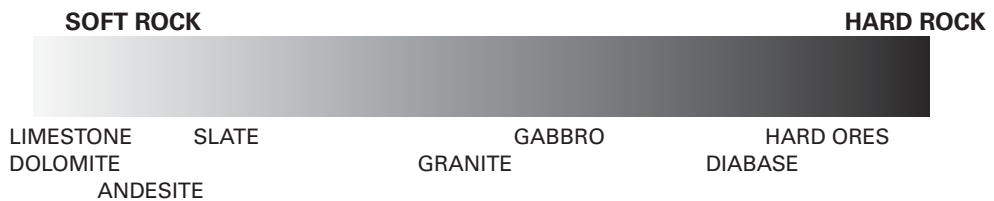
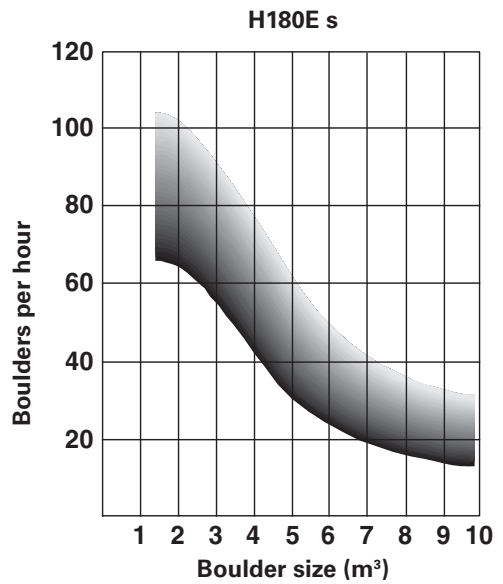
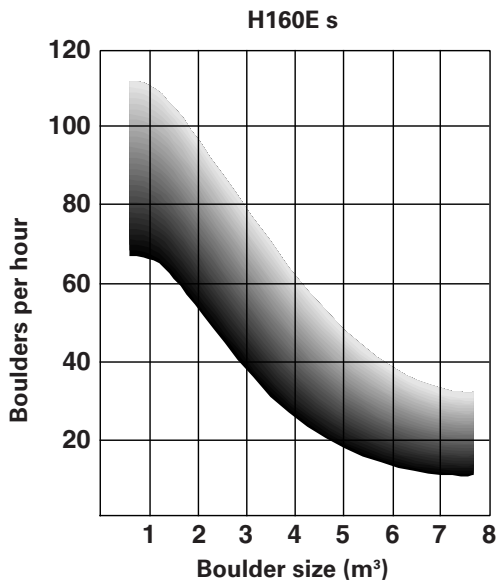
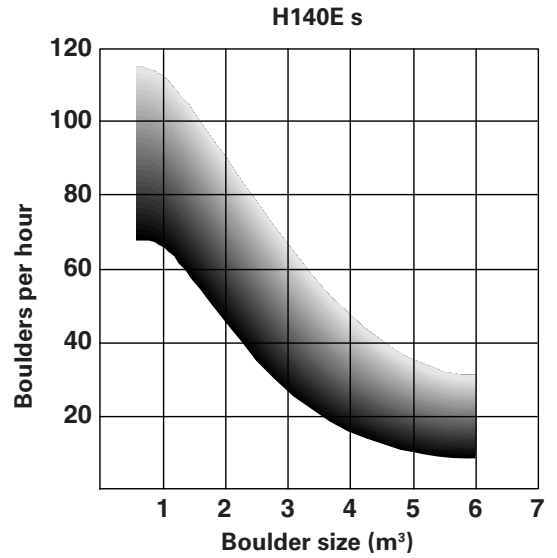
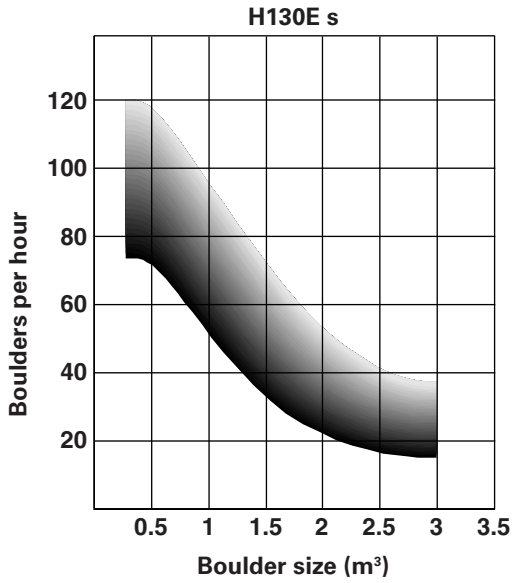

MOBILE SCRAP AND DEMOLITION SHEARS

C Series Shears incorporate a bolt-on piercing tip — a key feature for enhancing up time for shears.

- Changeable with common hand tools.
- Dual-sided protecting the moving jaw on both sides.
- Fully reversible tip and blades.

Cat Mobile Scrap and Demolition Shears are available in six sizes and feature:

- Straight lower, apex upper jaw design.
- 360 degree bidirectional rotation system.
- Adjustable hub allows users to maintain tolerances between the jaws in the field.
- High force to weight ratio.
- Long wearing alloy steel blades.
- Cutting edges mounted on the side of the shear jaws and are visible to the operator.
- Shears can be mounted on boom or stick.

Applications:

Cat Mobile Scrap and Demolition Shears are designed to cut and reduce the size of metal items commonly found in scrap yards, buildings, and other structures.

The profiles on the next page approximate shear cutting capacity. The cutting capacities listed on the next page were achieved by cutting the specified steel profiles with a shear operating pressure at 35 000 kPa (5075 psi) and knives in slightly used condition. Lower operating pressures, dull knife edges, and harder steels will obviously reduce cutting capability.

Guarding Recommendation

Shears used in hazardous applications like demolition, and scrap and material handling can create a need for special operator guarding due to flying or falling objects. When using a shear, additional protective devices such as a front screen, Falling Object Guarding System (FOGS, includes top and front guarding), thick polycarbonate windshields or a combination of these is recommended by Caterpillar. Contact your Cat dealer for operator guarding options on your machine.

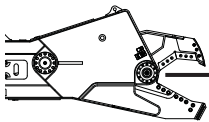
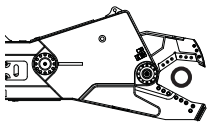
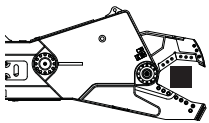
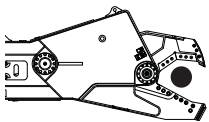
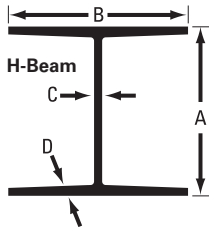
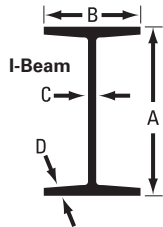

Model		S385C	S365C	S340B	S325B	S320B	S305
		I-Beams					
A Height	mm (in)	635 (25)	612 (24.1)	457.2 (18)	407 (16)	358 (14.1)	207 (8.1)
B Flange width	mm (in)	329 (13)	229 (9)	191 (7.5)	178 (7.0)	172 (6.8)	112 (4.4)
C Web thickness	mm (in)	18 (0.7)	12 (0.5)	9.017 (0.4)	7.7 (0.3)	7.8 (0.3)	5.8 (0.2)
D Flange thickness	mm (in)	31 (1.2)	20 (0.8)	15.24 (0.6)	12.7 (0.5)	12.7 (0.5)	8.4 (0.3)
Weight	kg/m (ft-lb)	241 (162)	125 (84)	74.4 (50)	59.5 (40)	56.5 (38)	22.3 (15)
		Wide I-Beams			H-Beams		
A Height	mm (in)	476 (18.7)	472 (18.6)	311 (12.2)	256 (10.1)	204 (8)	107 (4.2)
B Flange width	mm (in)	284 (11.2)	284 (11.2)	306 (12)	255 (10)	206 (8.1)	103 (4.1)
C Web thickness	mm (in)	24 (0.9)	13 (0.5)	10.9 (0.4)	9.4 (0.4)	7.9 (0.3)	7.11 (0.3)
D Flange thickness	mm (in)	15 (0.6)	22 (0.9)	10.9 (0.4)	9.4 (0.4)	7.9 (0.3)	8.8 (0.3)
Weight	kg/m (ft-lb)	158 (106)	144 (97)	107 (71.9)	80 (53.8)	52 (34.9)	19.4 (13)

Round							
Diameter	mm (in)	125 (5)	120 (4.75)	115 (4.5)	100 (4)	90 (3.5)	50.8 (2)

Square							
Width	mm (in)	120 (4.75)	100 (4)	90 (3.5)	90 (3.5)	65 (2.5)	40 (1.5)

Pipe (Schedule 40)							
Diameter	mm (in)	508 (20)	458 (18)	406 (16)	356 (14)	325 (12.8)	220 (8.6)
Wall thickness	mm (in)	15 (0.6)	15 (0.6)	13 (0.5)	11 (0.4)	10 (0.4)	8 (0.3)

Piercing							
Thickness	mm (in)	33 (1.38)	27 (1.25)	22 (0.88)	19 (0.75)	16 (0.63)	10 (0.38)

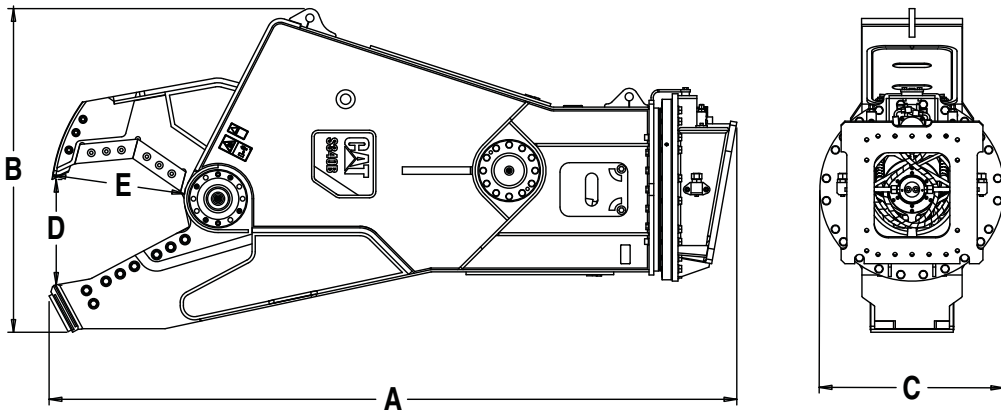

Model		S385C	S365C	S340B	S325B	S320B	S305
Weight*, boom-mount	kg	8320	6870	4695	3390	2570	608
	(lb)	(18,345)	(15,145)	(10,351)	(7474)	(5666)	(1340)
Weight*, stick-mount	kg	7975	6700	4386	2996	2165	580
	(lb)	(17,580)	(14,770)	(9670)	(6604)	(4774)	(1280)
Dimensions							
A Length	mm	4260	3840	3638	3177	2792	1709
	(in)	(168)	(151)	(143)	(125)	(110)	(67.3)
B Height	mm	2121	1900	1723	1525	1340	660
	(in)	(84)	(75)	(68)	(60)	(53)	(26)
C Width	mm	1400	1180	975	792	792	390
	(in)	(55)	(46)	(38)	(31)	(31)	(15)
Jaw width, fixed	mm	466	466	396	342	304	230
	(in)	(18)	(18)	(16)	(13)	(12)	(9)
Jaw width, moving	mm	150	150	120	100	90	60
	(in)	(6)	(6)	(5)	(4)	(3)	(2)
D Jaw opening	mm	879	845	563	528	409	240
	(in)	(35)	(33)	(22)	(21)	(16)	(9.4)
E Jaw depth	mm	903	840	703	571	459	290
	(in)	(35)	(33)	(28)	(22)	(18)	(11.4)

*Weight includes mounting bracket.

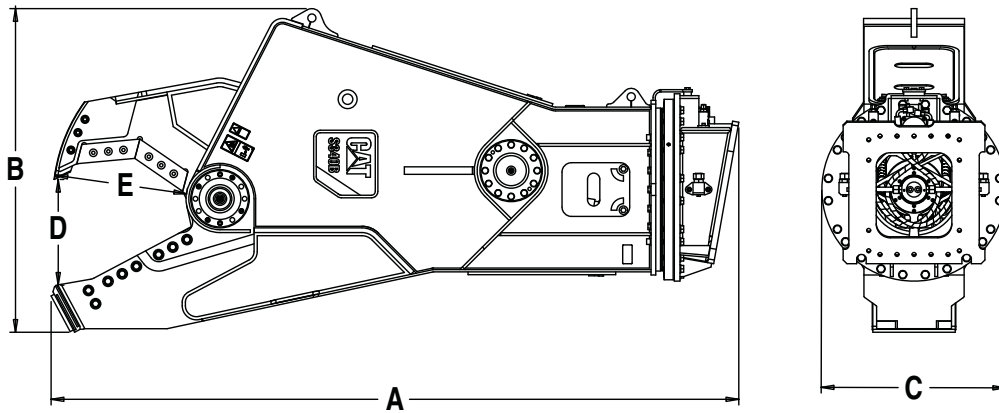

Model		S385C	S365C	S340B	S325B	S320B	S305
Shear Forces*							
Throat**	kN	12 509	10 342	6818	5562	3706	1812
	(st)	(1405)	(1162)	(766)	(625)	(417)	(204)
Apex	kN	4413	3576	2751	2221	1583	653
	(st)	(496)	(402)	(309)	(250)	(178)	(73)
Tip	kN	2455	1975	1558	1274	892	385
	(st)	(276)	(222)	(175)	(143)	(100)	(43)
Shear arm torque	kN·m	2779	2083	1374	931	534	140
	(lbf·ft)	(2,050,000)	(1,536,000)	(1,013,700)	(686,900)	(394,100)	(103,600)
Cycle time, open	seconds	5	5	5	5	4	3.5
Cycle time, close	seconds	3	3	3	3	3	2.5
Hydraulic Requirements, Cutting Circuit							
Maximum relief pressure	kPa	35 000	35 000	35 000	35 000	35 000	25 000
	(psi)	(5075)	(5075)	(5075)	(5075)	(5075)	(3625)
Maximum recommended flow	L/min	690	530	300	200	150	60
	(gpm)	(182)	(140)	(79)	(53)	(40)	(16)
Hydraulic Requirements, Rotation Circuit							
Maximum relief pressure	kPa	14 000	14 000	14 000	14 000	14 000	10 000
	(psi)	(2030)	(2030)	(2030)	(2030)	(2030)	(1450)
Maximum recommended flow	L/min	80	80	40	40	40*	20
	(gpm)	(21)	(21)	(11)	(11)	(11*)	(5)

*Calculated with a maximum operating pressure of 35 MPa (5075 psi).

**Measured at innermost cutting point of the jaw.

Matching Guide

Pin-On matches are shown below.

Matches are based on counterweight and grouser width on standard machines.

Wheeled excavator matches are calculated with all four stabilizers down.

Stick-Mount

Cat Excavator	Boom	Stick		S385C	S365C	S340B	S325B	S320B	S305
		m	(ft/in)						
390D L	GP	5.5	(18'1")		X				
		4.4	(14'5")	X	X				
		3.4	(11'2")	X	X				
		3.7	(12'2")	X	X				
		2.92	(9'7")	X	X				
374D L	Reach	4.15	(13'7")		X				
		3.6	(11'10")		X				
		2.84	(9'4")		X				
345D L – VG	Reach	3.9	(12'10")			X			
		3.35	(11'0")			X			
345D – FIX	Reach	3.9	(12'10")			X	X		
		3.3	(11'0")			X	X		
345C – DEM		28	(91'9")					X	
		26	(85'0")					X	
336D L/330D L	Reach	3.9	(12'10")				X	X	
		3.2	(10'6")				X	X	
329D L/325D L	Reach	3.2	(10'6")				X	X	
							X	X	
		2.65	(8'8")				X	X	
328D LCR	Reach	3.76	(12'4")					X	
		3.2	(10'6")				X	X	
		2.65	(8'8")				X	X	
324D L	Reach	3.6	(11'10")					X	
		2.95	(9'8")				X	X	
		2.5	(8'2")				X	X	
321D LCR	Reach	2.92	(9'6")					X	
		2.5	(8'2")					X	
320D L	Reach	2.92	(9'6")					X	
		2.5	(8'2")					X	
320D LRR	Reach	2.92	(9'6")					X	
		2.5	(8'2")					X	
	Reach-HD	2.92	(9'6")					X	
		2.5	(8'3")					X	
319D L	Reach	2.7	(8'10")					X	
		2.25	(7'5")					X	
M322D	One-Piece	2.5	(8'2")					X	
		2.2	(7'3")					X	
M318D	One-Piece	2.8	(9'2")					X	
		2.5	(8'2")					X	
		2.2	(7'3")					X	
M316D	One-Piece	2.4	(7'10")					X	
		2.1	(6'11")					X	
M315D	One-Piece	2.4	(7'10")					X	
		2.1	(6'11")					X	
308D CR	One-Piece	2.2	(7'3")						X
		1.7	(5'6")						X
307D	One-Piece	2.2	(7'3")						X
		1.7	(5'6")						X

Pin-on matches are shown above. Please reference bulletin GEJH0016 for matching information when utilizing a pin-grabber or dedicated coupler.

DEM = Demolition machine

VG = Variable wide gauge undercarriage

FIX = Fixed undercarriage

Matching Guide

Matches are based on counterweight and grouser width on standard machines.
Wheeled excavator matches are calculated with all four stabilizers down.

Boom-Mount

Cat Excavator	Boom	S385C	S365C	S340B	S325B	S320B	S305
365C L	Reach	X					
345D L – VG	Reach	X	X				
345D – FIX	Reach	X	X				
336D L/330D L	Reach		X	X			
329D L/325D L	Reach			X			
328D L CR	Reach			X			
324D L	Reach			X			
321D L CR	Reach						
320D L	Reach				X		
320D LRR	Reach				X		
	Reach-HD				X		
319D L	Reach				X	X	
315D L	Reach				X	X	
314D CR	Reach					X	
312D L	Reach					X	
311D LRR	Reach					X	
M322D	One-Piece			X			
M318D	One-Piece			X	X		
M316D	One-Piece			X	X		
M315D	One-Piece				X	X	
M313D	One-Piece				X	X	
305D CR	One-Piece						X
304D CR	One-Piece						X
303.5D CR	One-Piece						X

Cat S305 is a match for all Skid Steer Loaders 236B2 and larger and all Multi-Terrain Loaders.

Please reference bulletin GEJH0016 for matching information when utilizing a pin-grabber or dedicated coupler.
VG = Variable wide gauge undercarriage
FIX = Fixed undercarriage

MULTI-PROCESSORS

Features:

- **Wide selection** of interchangeable jaws.
- **Lifting eye placement** and adjustable stop bolts allow quick jaw changes.
- **Single, large diameter** cross mounted cylinder provides exceptional cutting and crushing force.
- **Jaws are manufactured** of high quality tool steel with outstanding tensile strength.
- **Non impact** tools that work at a relatively low noise level.

Applications:

The Cat Multi-Processors can be used to accomplish most tasks on a demolition job. One common housing with a wide selection of interchangeable jaws allows the tool to cut, crush or pulverize the toughest of materials. Highly reinforced concrete, structural steel beams, pipes, cable, steel plate and storage tanks.

Matching Guide

Stick Mounted/Reach Boom

Multi-Processors Model	Cat Excavator
MP318	318E, 319D, 320D/E, 320D/E RR, 321D CR, 323D/E, 324D/E M315D, M316D, M318D, M322D, M318D MH, M322 MH DEM50, DEM70, DEM100
MP324	323D, 324D/E, 328D CR, 329D/E, 336D/E DEM50, DEM70, DEM100
MP30	330D 345C 365C UHD, 385C UHD
MP40	365C, 385C

These matches are for general reference purpose for Cat machines only. Please always check the stability of the machine-tool configuration. The stability depends on application, tool used and your machine configuration. For questions please contact your Cat dealer. When choosing between various multi-processor models that can be installed onto the same machine configuration, consider work tool application, productivity requirements, and durability.

CAT MULTI-PROCESSOR INTERCHANGEABLE JAWS

Concrete Cutter Jaws (CC)

- For precise demolition/cutting of heavily reinforced concrete structures.
- Cuts structural steel and pipe.
- Equipped with replaceable concrete crusher teeth and reversible steel cutting knives.

Shear Jaws (S)

- For demolition of steel structures.
- Cuts angle and channel iron, beams, pipe, rebar, cable and tires.
- Knives are reversible.

Tank Shear Jaws (TS)

- Quickly cuts steel plate on barges, railway cars, grain, water, oil, and fuel tanks. Dual knives on the moving and static jaws produce smooth, straight edges.
- All knives are reversible.
- Available for MP20 and MP30 only.

Crusher Jaws (CR)

- For demolition of moderately reinforced concrete structures. Capable of crushing concrete and cutting rebar.
- Replaceable crusher teeth and reversible knives.

Primary Pulverizer Jaws (PP)

- Combines capability to demolish and recycle moderately reinforced concrete structures. Pulverizes concrete, cuts rebar and separates rebar from concrete. (Not available for MP40.)
- Replaceable crusher teeth and reversible knives.

Secondary Pulverizer Jaws (PS)

- Recycles demolished concrete by pulverizing concrete, separating concrete and rebar, and cutting rebar as needed.

All jaw sets can be interchanged quickly with the lifting eyes and the adjustable stopbolts on jaws and body.

Guarding Recommendation

Multi-Processors used in hazardous applications like demolition, and scrap and material handling can create a need for special operator guarding due to flying or falling objects. When using a Multi-Processor, additional protective devices such as a front screen, Falling Object Guarding System (FOGS, includes top and front guarding), thick polycarbonate windshields or a combination of these is recommended by Caterpillar. Contact your Cat dealer for operator guarding options on your machine.

Specifications (All dimensions are approximate.)

Model	MP318		MP324	
Carrier weight	18-25 mt	39,500-55,000 lb	24-35 mt	53,000-77,000 lb
Housing weight, jaw	1930 kg	4255 lb	2610 kg	5754 lb
Weight of the jaw	660-850 kg	1455-1874 lb	940-1160 kg	2072-2557 lb
Maximum pressure (open/close)	350 bar	5076 psi	350 bar	5076 psi
Flow (open/close)	150 L/min	33 gpm	225 L/min	50 gpm
Pressure rotation	140 bar	2030 psi	140 bar	2030 psi
Flow rotation	40 L/min	10.6 gpm	40 L/min	10.6 gpm
Return flow opening	240 L/min	53 gpm	370L/min	81 gpm
Cycle time (open/close)	1.6/1.0 sec		1.8/1.2 sec	
Model	MP30		MP40	
Weight total — housing, jaw and bracket	3850 kg	8190 lb	6370 kg	14,045 lb
Weight of the jaw	1260 kg	2780 lb	2230 kg	4915 lb
Dimensions:				
Length	2800 mm	110.2"	3500 mm	137.8"
Height	1980 mm	78"	2340 mm	92.1"
Width	1010 mm	39.8"	1180 mm	46.5"
Jaw width (fixed)	380 mm	15"	460 mm	18.1"
Jaw width (moving)	130 mm	5.1"	160 mm	6.3"
Jaw opening	975 mm	38.4"	1280 mm	50.4"
Jaw depth	890 mm	35"	1100 mm	43.3"
Cutter length	520 mm	20.5"	600 mm	23.6"
Maximum crushing/shear force:				
Tooth — jaw tip	1250 kN	140 st	1500 kN	168 st
Front cutter tip	1850 kN	208 st	2200 kN	247 st
Primary blade center	4100 kN	460 st	4400 kN	494 st
Maximum oil flow:				
Hydraulic cylinder	300 L/min	79 gpm	400 L/min	106 gpm
Cycle time (open, close, open)	6.5 sec		7.5 sec	
Rotation	40 L/min	11 gpm	80 L/min	22 gpm
Maximum working pressure:				
Hydraulic cylinder	35 000 kPa	5075 psi	35 000 kPa	5075 psi
Rotation	14 000 kPa	2030 psi	14 000 kPa	2030 psi

Specifications (All dimensions are approximate.)

Jaw Type	MP318-CC		MP318-D		MP318-P		MP318-S		MP318-U	
Housing weight, jaw	1930 kg	4255 lb	1910 kg	4211 lb	2030 kg	4475 lb	1840 kg	4056 lb	1980 kg	4365 lb
Weight of the jaw	750 kg	1653 lb	730 kg	1609 lb	850 kg	1874 lb	660 kg	1455 lb	770 kg	1697 lb
Closing force:										
Tooth tip	75 mt	83 st	75 mt	83 st	75 mt	83 st	100 mt	110 st	85 mt	94 st
Cutter tip/tooth	110 mt	121 st	110 mt	121 st	110 mt	121 st	170 mt	187 st	160 mt	176 st
Primary cutter	225 mt	248 st	230 mt	248 st	250 mt	248 st	370 mt	408 st	300 mt	331 st
Jaw opening	685 mm	26.96"	740 mm	29.13"	820 mm	32.28"	350 mm	13.77"	470 mm	18.50"
Jaw depth	650 mm	25.59"	650 mm	25.59"	670 mm	26.37"	500 mm	19.68"	570 mm	22.44"
Cutting capacity:										
Narrow I-beams	IPE300		N/A		N/A		IPE300		N/A	
Wide I-beams	HE-A200		N/A		N/A		HE-A200		N/A	
Round bar	65 mm	2.55"	N/A		N/A		65 mm	2.55"	N/A	
Square bar	60 mm	2.36"	N/A		N/A		60 mm	2.36"	N/A	
Plate	N/A		N/A		N/A		219 x 8 mm	8.62 x 0.31"	N/A	
Crushing capacity:										
Concrete thickness	550 mm	21.65"	600 mm	23.62"	550 mm	21.65"	N/A		450 mm	17.71"

Specifications (All dimensions are approximate.)

Jaw Type	MP324-CC		MP324-D		MP324-P	
Housing weight, jaw	2610 kg	5754 lb	2640 kg	5820 lb	2740 kg	6040 lb
Weight of the jaw	1030 kg	2270 lb	1060 kg	2327 lb	1160 kg	2327 lb
Closing force:						
Tooth tip	105 mt	116 st	105 mt	116 st	105 mt	116 st
Cutter tip/tooth	150 mt	165 st	150 mt	165 st	150 mt	165 st
Primary cutter	320 mt	353 st	320 mt	353 st	340 mt	353 st
Jaw opening	830 mm	32.67"	905 mm	35.62"	970 mm	38.18"
Jaw depth	760 mm	29.92"	760 mm	29.92"	760 mm	29.92"
Cutting capacity:						
Narrow I-beams		IPE400		N/A		N/A
Wide I-beams		HE-A260		N/A		N/A
Round bar	80 mm	3.14"		N/A		N/A
Square bar	70 mm	2.75"		N/A		N/A
Crushing capacity:						
Concrete thickness	650 mm	25.59"	700 mm	27.55"	650 mm	25.59"

Specifications (All dimensions are approximate.)

Jaw Type	MP324-S		MP324-U		MP324-TS	
Housing weight, jaw	2530 kg	5577 lb	2690 kg	5930 lb	2740 kg	6040 lb
Weight of the jaw	940 kg	2072 lb	1100 kg	2425 lb	1130 kg	2492 lb
Closing force:						
Tooth tip	130 mt	143 st	115 mt	127 st	110 mt	121 st
Cutter tip/tooth	230 mt	254 st	160 mt	176 st	130 mt	143 st
Primary cutter	390 mt	430 st	350 mt	386 st	300 mt	331 st
Jaw opening	400 mm	15.74"	650 mm	25.59"	500 mm	19.68"
Jaw depth	620 mm	24.40"	680 mm	26.77"	490 mm	19.29"
Cutting capacity:						
Narrow I-beams		IPE400		N/A		N/A
Wide I-beams		HE-A260		N/A		N/A
Round bar	80 mm	3.14"		N/A		N/A
Square bar	70 mm	2.75"		N/A		N/A
Crushing capacity:						
Concrete thickness		N/A	600 mm	23.62"		N/A

Specifications (All dimensions are approximate.)

Model	MP30		MP40	
Weight total — housing, jaw and bracket	3890 kg	8575 lb	6430 kg	14,175 lb
Weight of the jaw	1300 kg	2865 lb	2200 kg	4850 lb
Dimensions:				
Length	2700 mm	106.3"	3400 mm	133.9"
Height	1680 mm	66.1"	1980 mm	78"
Width	1010 mm	39.8"	1180 mm	46.5"
Jaw width (fixed)	370 mm	14.6"	460 mm	18.1"
Jaw width (moving)	120 mm	4.7"	150 mm	5.9"
Jaw opening	470 mm	18.5"	630 mm	24.8"
Jaw depth	710 mm	28"	880 mm	34.6"
Cutter length	600 mm	23.6"	760 mm	29.9"
Maximum shear force:				
At tip	1600 kN	180 st	1900 kN	213 st
Primary blade center	3750 kN	421 st	4750 kN	534 st
At throat	7100 kN	798 st	8950 kN	1006 st
Maximum oil flow:				
Hydraulic cylinder	300 L/min	79 gpm	400 L/min	106 gpm
Cycle time (open, close, open)		6.5 sec		7.5 sec
Rotation	40 L/min	11 gpm	80 L/min	22 gpm
Maximum working pressure:				
Hydraulic cylinder	35 000 kPa	5075 psi	35 000 kPa	5075 psi
Rotation	14 000 kPa	2030 psi	14 000 kPa	2030 psi

Specifications (All dimensions are approximate.)

Model	MP20		MP30	
Weight total — housing, jaw and bracket	2740 kg	6040 lb	4380 kg	9655 lb
Weight of the jaw	1010 kg	2225 lb	1790 kg	3945 lb
Dimensions:				
Length	2400 mm	94.5"	2800 mm	110.2"
Height	1750 mm	68.9"	2100 mm	82.7"
Width	800 mm	31.5"	1180 mm	46.5"
Jaw width (fixed)	290 mm	11.4"	340 mm	13.4"
Jaw width (moving)	120 mm	4.7"	150 mm	5.9"
Jaw opening	440 mm	17.3"	510 mm	20.1"
Jaw depth	460 mm	18.1"	580 mm	22.8"
Cutter length	460 mm	18.1"	580 mm	22.8"
Maximum shear force:				
At tip	1400 kN	157 st	1900 kN	213 st
At jaw center	2200 kN	247 st	4000 kN	449 st
At throat	4400 kN	494 st	6350 kN	714 st
Cutting capacity plate steel	25 mm	1"	30 mm	1.2"
Maximum oil flow:				
Hydraulic cylinder	200 L/min	53 gpm	200 L/min	53 gpm
Cycle time (open, close, open)		6 sec		6.5 sec
Rotation	40 L/min	11 gpm	40 L/min	11 gpm
Maximum working pressure:				
Hydraulic cylinder	35 000 kPa	5075 psi	35 000 kPa	5075 psi
Rotation	14 000 kPa	2030 psi	14 000 kPa	2030 psi

Specifications (All dimensions are approximate.)

Model	MP30		MP40	
Weight total — housing, jaw and bracket	3860 kg	8510 lb	6370 kg	14,045 lb
Weight of the jaw	1270 kg	2800 lb	2230 kg	4915 lb
Dimensions:				
Length	2770 mm	102"	3500 mm	137.8"
Height	1980 mm	78"	2380 mm	93.7"
Width	1010 mm	39.8"	1180 mm	46.5"
Jaw width (fixed)	380 mm	15"	460 mm	18.1"
Jaw width (moving)	130 mm	5.1"	160 mm	6.3"
Jaw opening	1050 mm	41.3"	1320 mm	52"
Jaw depth	920 mm	36.2"	1100 mm	43.3"
Cutter length	260 mm	10.2"	250 mm	9.8"
Maximum crushing/shear force:				
Tooth — jaw tip	1250 kN	140 st	1500 kN	168 st
At 2 nd tooth	1750 kN	197 st	2200 kN	247 st
Primary blade center	3800 kN	427 st	4650 kN	523 st
Maximum oil flow:				
Hydraulic cylinder	300 L/min	79 gpm	400 L/min	106 gpm
Cycle time (open, close, open)		6.5 sec		7.5 sec
Rotation	40 L/min	11 gpm	80 L/min	22 gpm
Maximum working pressure:				
Hydraulic cylinder	35 000 kPa	5075 psi	35 000 kPa	5075 psi
Rotation	14 000 kPa	2030 psi	14 000 kPa	2030 psi

Specifications (All dimensions are approximate.)

Model	MP30	
Weight total — housing, jaw and bracket	4180 kg	9215 lb
Weight of the jaw	1590 kg	3505 lb
Dimensions:		
Length	2800 mm	110.2"
Height	1980 mm	78"
Width	1010 mm	39.8"
Jaw width (fixed)	610 mm	24"
Jaw width (moving)	370 mm	14.6"
Jaw opening	960 mm	37.8"
Jaw depth	940 mm	37"
Cutter length	250 mm	9.8"
Maximum crushing/shear force:		
Tooth — jaw tip	1250 kN	140 st
At 2 nd tooth	1550 kN	174 st
Primary blade center	3950 kN	444 st
Maximum oil flow:		
Hydraulic cylinder	300 L/min	79 gpm
Cycle time (open, close, open)	6.5 sec	
Rotation	40 L/min	11 gpm
Maximum working pressure:		
Hydraulic cylinder	35 000 kPa	5075 psi
Rotation	14 000 kPa	2030 psi

Specifications (All dimensions are approximate.)

Model	MP30		MP40	
Weight total — housing, jaw and bracket	4080 kg	8995 lb	6730 kg	14,835 lb
Weight of the jaw	1490 kg	3285 lb	2590 kg	5710 lb
Dimensions:				
Length	2950 mm	116.1"	3650 mm	143.7"
Height	2200 mm	86.6"	2550 mm	100.4"
Width	1010 mm	39.8"	1180 mm	46.5"
Jaw width (fixed)	580 mm	22.8"	700 mm	27.6"
Jaw width (moving)	420 mm	16.5"	480 mm	18.9"
Jaw opening	1100 mm	43.3"	1400 mm	55.1"
Jaw depth	970 mm	38.2"	1170 mm	46"
Cutter length	200 mm	7.9"	250 mm	9.8"
Maximum crushing/shear force:				
Tooth — jaw tip	1250 kN	141 st	1500 kN	168 st
At 2 nd tooth	1550 kN	174 st	1900 kN	213 st
Primary blade center	4800 kN	539 st	5500 kN	618 st
Maximum oil flow:				
Hydraulic cylinder	300 L/min	79 gpm	400 L/min	106 gpm
Cycle time (open, close, open)		6.5 sec		7.5 sec
Rotation	40 L/min	11 gpm	80 L/min	22 gpm
Maximum working pressure:				
Hydraulic cylinder	35 000 kPa	5075 psi	35 000 kPa	5075 psi
Rotation	14 000 kPa	2030 psi	14 000 kPa	2030 psi

Cutting Capacity

Model	MP30		MP40	
Narrow I-beams:				
Height	500 mm	19.7"	600 mm	23.6"
Flange width	200 mm	7.9"	600 mm	8.7"
Flange thickness	16 mm	0.63"	19 mm	0.75"
Web thickness	10.2 mm	0.4"	12 mm	0.47"
Wide I-beams:				
Height	310 mm	12.2"	390 mm	15.4"
Flange width	300 mm	11.8"	300 mm	11.8"
Flange thickness	15.5 mm	0.61"	19 mm	0.75"
Web thickness	9 mm	0.35"	11 mm	0.43"
Solid-round	90 mm	3.5"	100 mm	3.9"
Solid-square	80 mm	3.1"	90 mm	3.5"

The above profiles provide an indication of the shear's cutting capability. The exact cutting dimensions depend on excavator size, the conditions of the cutters and jaws and the tensile strength of the steel.

CONTRACTOR'S GRAPPLES

Features:

- Fits multiple linkages simply by changing the pin group.
- Designed with less curve allowing material to flow easily out of the grapple, simplifying material loading and unloading.
- Large wear areas made entirely of AR400 steel.
- Matches the entire range of small, medium and large excavators.
- Two-over-three tines interlock to securely grasp and retain more material when sorting and loading.
- Sized to match Cat machines making them able to better realize the machine's maximum performance; both break out and lift capacity.
- One grapple can be used with or without a coupler with no modifications.

Applications:

Contractor's Grapples are built to handle demolition of brick and wood structures, land clearing, sorting and loading of rock, scrap, pipe, waste material and demolition debris.

Guarding Recommendation

Contractor's Grapples used in hazardous applications like demolition, and scrap and material handling can create a need for special operator guarding due to flying or falling objects. When using a Contractor's Grapple, additional protective devices such as a front screen, Falling Object Guarding System (FOGS, includes top and front guarding), thick polycarbonate windshields or a combination of these is recommended by Caterpillar. Contact your Cat dealer for operator guarding options on your machine.

Matching Guide

Contractor's Grapples

Model	Cat Excavator
G107B	307 CR
G112B	312C
G115B	315C
G120B	320D 322C 324D 325D
G125B	320D 322C 324D 325D
G130B	320D 322C 324D 325D 330D
G145B	345C
G165B	345C 350 365C
G185B	385C

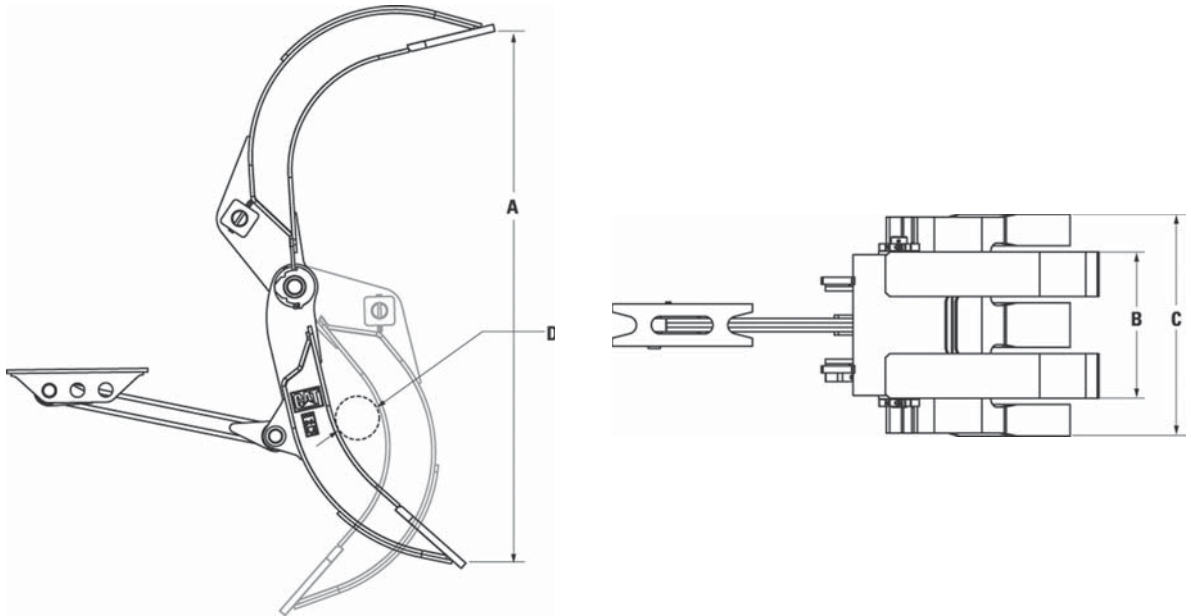

Specifications (All dimensions are approximate.)

Model	G107B		G112B		G115B		G120B		G125B	
Weight	360 kg	794 lb	857 kg	1885 lb	1286 kg	2830 lb	1523 kg	3350 lb	1932 kg	4250 lb
A Jaw Opening	1765 mm	69.5"	2195 mm	86.4"	2555 mm	100.6"	2687 mm	105.8"	3128 mm	123.1"
B Upper Tine Width	435 mm	17.1"	550 mm	21.7"	610 mm	24"	617 mm	24.3"	704 mm	27.7"
C Lower Tine Width	735 mm	28.9"	900 mm	35.4"	1020 mm	40.2"	1031 mm	40.6"	1150 mm	45.3"
D Minimum Opening	134 mm	5.3"	186 mm	7.3"	191 mm	7.5"	199 mm	7.8"	245 mm	9.6"
Inner Wrapper Thickness	8 mm	0.3"	12 mm	0.5"	12 mm	0.5"	16 mm	0.6"	16 mm	0.6"
Outer Wrapper Thickness	8 mm	0.3"	12 mm	0.5"	12 mm	0.5"	12 mm	0.5"	16 mm	0.6"
Wear Tip Thickness	12 mm	0.5"	20 mm	0.8"	25 mm	1"	30 mm	1.2"	40 mm	1.6"
Outer Wear Plate Thickness	12 mm	0.5"	16 mm	0.6"	25 mm	1"	20 mm	0.8"	20 mm	0.8"

Model	G130B		G145B		G165B		G185B	
Weight	2332 kg	5130 lb	3050 kg	6724 lb	4055 kg	8940 lb	4800 kg	10,582 lb
A Jaw Opening	3223 mm	126.9"	3433 mm	135.2"	3860 mm	152"	4076 mm	160.5"
B Upper Tine Width	832 mm	32.8"	865 mm	34.1"	937 mm	36.9"	985 mm	38.8"
C Lower Tine Width	1262 mm	49.7"	1335 mm	52.6"	1406 mm	55.4"	1535 mm	60.4"
D Minimum Opening	319 mm	12.6"	271 mm	10.7"	283 mm	11.1"	337 mm	13.3"
Inner Wrapper Thickness	20 mm	0.8"	20 mm	0.8"	25 mm	1"	25 mm	1"
Outer Wrapper Thickness	20 mm	0.8"	20 mm	0.8"	25 mm	1"	25 mm	1"
Wear Tip Thickness	40 mm	1.6"	40 mm	1.6"	40 mm	1.6"	40 mm	1.6"
Outer Wear Plate Thickness	20 mm	0.8"	25 mm	1"	30 mm	1.2"	30 mm	1.2"

Features:

- **360 Degree Rotation.** Slewing ring rotation system is proven and reliable.
- **Wide Jaw Opening** handles large objects and payloads.
- **Jaw Edges** are synchronized, always closing edge to edge in the center. Pick and sort even the smallest material.
- **Grapple Body and Jaws** are made from high-grade impact-resistant steel.
- **Reinforced Jaws** handle extreme use.
- **Outer Jaw Profile** is vertical when open for working against a wall or inside containers.

Matching Guide

Model	Cat Excavator
G310B	311-316
	M313-M316
G315B	318-321
	M315-M322
G320B	324-329
	330-385 UHD
	Apex 70-100
G325B	324-336
	330-385 UHD
	Apex 70-100
G330	329-349
	Apex 70-100

Demolition and Sorting Grapples Americas North and South, Europe, Africa, Middle East

Specifications

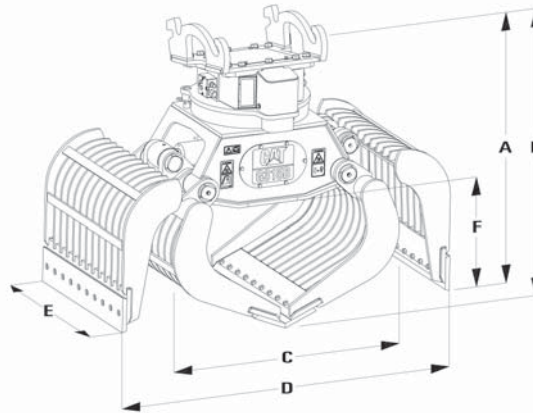

Specifications (All dimensions are approximate.)

Model	G303 (Demolition/ Recycling)		G305 (Demolition/ Recycling)		G310B (Demolition)		G310B (Recycling**)	
	Capacity	140 L	0.18 yd³	140 L	0.18 yd³	375 L	0.49 yd³	400 L
Weight*	420 kg	926 lb	420 kg	926 lb	1030 kg	2270 lb	985 kg	2171 lb
Dimensions:								
A Length	1160 mm	45.6"	1160 mm	45.6"	1350 mm	53"	1350 mm	53"
B Length	1040 mm	41"	1040 mm	41"	1440 mm	57"	1440 mm	57"
C Length	875 mm	34.4"	875 mm	34.4"	1245 mm	49"	1225 mm	48"
D Length	1650 mm	65"	1650 mm	65"	1800 mm	71"	1800 mm	71"
E Width	515 mm	20.3"	515 mm	20.3"	850 mm	33"	850 mm	33"
F Height	—	—	—	—	520 mm	20"	520 mm	20"
Closing force	15 kN	3372 lbf	15 kN	3372 lbf	36 kN	8100 lbf	36 kN	8100 lbf
Hydraulic for open/close:								
Maximum pressure	300 bar	4351 psi	300 bar	4351 psi	350 bar	5076 psi	350 bar	5076 psi
Maximum flow	40 L/min	10.6 gpm	40 L/min	10.6 gpm	60 L/min	15.9 gpm	60 L/min	15.9 gpm
Connection	—	—	—	—	-12	-12	-12	-12
Hydraulic for rotation:								
Maximum pressure	—	—	300 bar	4351 psi	350 bar	5076 psi	350 bar	5076 psi
Optimum flow	—	—	40 L/min	10.6 gpm	60 L/min	15.9 gpm	60 L/min	15.9 gpm
Connection	—	—	—	—	-8	-8	-8	-8
Excavator — class	3.5-6.5 mt	3.9-7.2 st	3.5-6.5 mt	3.9-7.2 st	9.1-14.5 mt	10-16 st	9.1-14.5 mt	10-16 st

*Weights exclude standard Quick Coupler mounting brackets.

**Not available in the Americas.

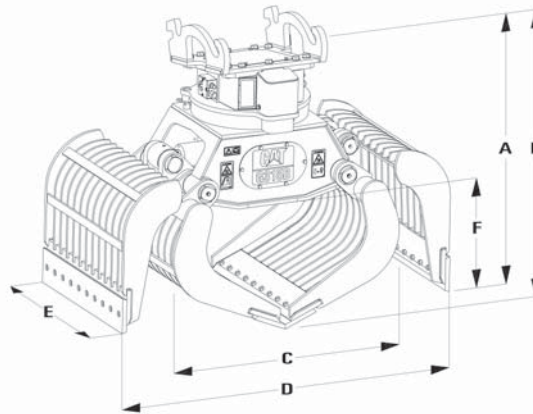

Specifications (All dimensions are approximate.)

Model	G315B (Demolition)		G315B (Recycling**)		G320B (Demolition)	
	Capacity	550 L	1.3 yd ³	600 L	0.78 yd ³	750 L
Weight*	1400 kg	3086 lb	1350 kg	2976 lb	1875 kg	4133 lb
Dimensions:						
A Length	1455 mm	57"	1455 mm	57"	1630 mm	64"
B Length	1550 mm	61"	1550 mm	61"	1725 mm	68"
C Length	1375 mm	54"	1360 mm	54"	1540 mm	61"
D Length	2000 mm	79"	2000 mm	79"	2200 mm	87"
E Width	1000 mm	39"	1000 mm	39"	1100 mm	43"
F Height	570 mm	22"	570 mm	22"	625 mm	25"
Closing force	52 kN	11,700 lbf	52 kN	11,700 lbf	66 kN	14,850 lbf
Hydraulic for open/close:						
Maximum pressure	350 bar	5076 psi	350 bar	5076 psi	350 bar	5076 psi
Maximum flow	90 L/min	23.8 gpm	90 L/min	23.8 gpm	120 L/min	31.7 gpm
Connection		-12		-12		-16
Hydraulic for rotation:						
Maximum pressure	140 bar	2030 psi	140 bar	2030 psi	140 bar	2030 psi
Optimum flow	40 L/min	10.6 gpm	40 L/min	10.6 gpm	40 L/min	10.6 gpm
Connection		-8		-8		-8
Excavator — class	13.6-20.0 mt	15-22 st	13.6-20.0 mt	15-22 st	18.1-26.3 mt	20-29 st

*Weights exclude standard Quick Coupler mounting brackets. Also available with fixed upperhead version.

**Not available in the Americas.

Model	G315BWH (Waste Handling)		G315B	
Width	1100 mm	43.3"	1000 mm	39.4"
Opening	2200 mm	86.6"	2000 mm	78.7"
Tip force	49.5 kN	11,128 lbf	52 kN	11,690 lbf
BOCE		G320B		G315B
Weight	1450 kg	3190 lb	1405 kg	3091 lb
Volume	800 L	1.0 yd ³	600 L	0.8 yd ³

Matching: M318, M322, 319, 320, 321 and 323.

**Demolition and
Sorting Grapples
Americas North and South,
Europe, Africa, Middle East**

Specifications

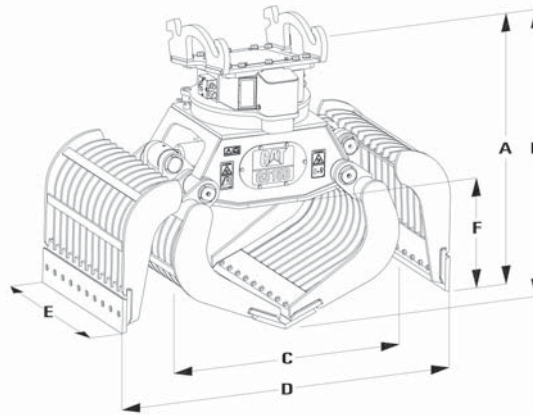

Specifications (All dimensions are approximate.)

Model	G320B (Recycling**)		G325B (Demolition)		G325B (Recycling**)	
	Capacity	800 L	1.05 yd³	900 L	1.18 yd³	900 L
Weight*	1820 kg	4012 lb	2040 kg	4497 lb	2090 kg	4607 lb
Dimensions:						
A Length	1630 mm	64"	1630 mm	64"	1630 mm	64"
B Length	1725 mm	68"	1725 mm	68"	1725 mm	68"
C Length	1505 mm	59"	1540 mm	61"	1540 mm	61"
D Length	2200 mm	87"	2200 mm	87"	2200 mm	87"
E Width	1100 mm	43"	1350 mm	53"	1350 mm	53"
F Height	625 mm	25"	625 mm	25"	625 mm	25"
Closing force	66 kN	14,850 lbf	66 kN	14,850 lbf	66 kN	14,850 lbf
Hydraulic for open/close:						
Maximum pressure	350 bar	5076 psi	350 bar	5076 psi	350 bar	5076 psi
Maximum flow	120 L/min	31.7 gpm	120 L/min	31.7 gpm	120 L/min	31.7 gpm
Connection		-16		-16		-16
Hydraulic for rotation:						
Maximum pressure	140 bar	2030 psi	140 bar	2030 psi	140 bar	2030 psi
Optimum flow	40 L/min	10.6 gpm	40 L/min	10.6 gpm	40 L/min	10.6 gpm
Connection		-8		-8		-8
Excavator — class	18.1-26.3 mt	20-29 st	25-38 mt	27.5-41.8 st	25-38 mt	27.5-41.8 st

*Weights exclude standard Quick Coupler mounting brackets. G320B is also available with fixed upperhead version.

**Not available in the Americas.

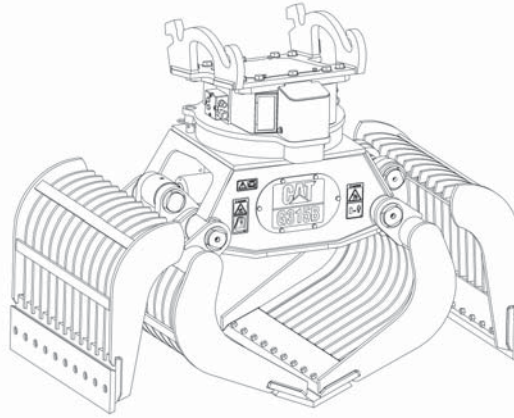
Specifications (All dimensions are approximate.)

Model	Fixed Upper Head					
	G310 GC		G313 GC		G315 GC	
Operating weight	865 kg	1903 lb	895 kg	1969 lb	1200 kg	2640 lb
Height open	1272 mm	50"	1272 mm	50"	1365 mm	54"
Height closed	1365 mm	54"	1365 mm	54"	1475 mm	58"
Shell width	850 mm	33"	950 mm	37"	1000 mm	39"
Capacity	400 L	0.52 yd³	450 L	0.59 yd³	600 L	0.78 yd³
Operating maximum pressure						
Open/closing	35 000 kPa	5076 psi	35 000 kPa	5076 psi	35 000 kPa	5076 psi
Rotation	22 000 kPa	3191 psi	22 000 kPa	3191 psi	22 000 kPa	3191 psi
Operating flow						
Open/closing	60 L/min	16 gpm	60 L/min	16 gpm	90 L/min	24 gpm
Rotation	40 L/min	11 gpm	40 L/min	11 gpm	40 L/min	11 gpm
Closing force	36 kN	8093 lbf	36 kN	8093 lbf	52 kN	11,690 lbf

**Demolition and
Sorting Grapples
Americas North and South,
Europe, Africa, Middle East**

Specifications

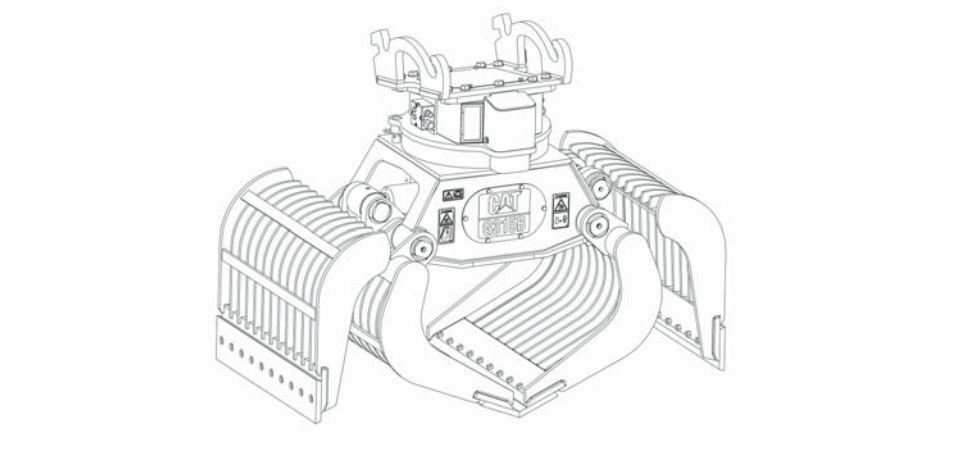

Specifications (All dimensions are approximate.)

Model	Flat Top Upper Head					
	G310 GC		G313 GC		G315 GC	
Operating weight	814 kg	1791 lb	845 kg	1859 lb	1142 kg	2512 lb
Height open	1223 mm	48"	1223 mm	48"	1326 mm	52"
Height closed	1315 mm	52"	1315 mm	52"	1427 mm	56"
Shell width	850 mm	33"	950 mm	37"	1000 mm	39"
Capacity	400 L	0.52 yd³	450 L	0.59 yd³	600 L	0.78 yd³
Operating maximum pressure						
Open/closing	35 000 kPa	5076 psi	35 000 kPa	5076 psi	35 000 kPa	5076 psi
Rotation	22 000 kPa	3191 psi	22 000 kPa	3191 psi	22 000 kPa	3191 psi
Operating flow						
Open/closing	60 L/min	16 gpm	60 L/min	16 gpm	90 L/min	24 gpm
Rotation	40 L/min	11 gpm	40 L/min	11 gpm	40 L/min	11 gpm
Closing force	36 kN	8093 lbf	36 kN	8093 lbf	52 kN	11,690 lbf

Features:

- Continuous, bi-directional 360° hydraulic rotation.
- Heavy-duty, fully protected cylinders.
- Tines constructed of high-strength wear-resistant steel.

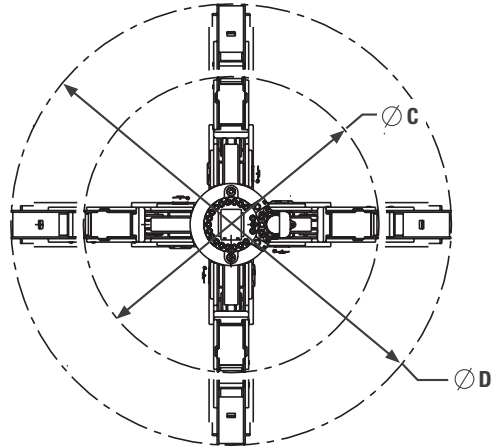
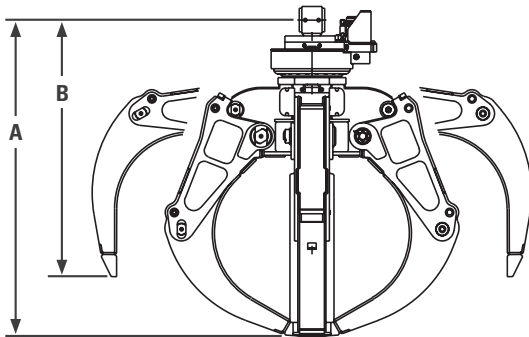

Model		GSH15B	GSH20B		GSH22B		
Part number		293-3202	292-6768	292-7730	292-7743	259-9691	259-9704
Industry capacity class	L (yd ³)	600 (0.75)	600 (0.75)	800 (1.00)	1000 (1.25)	1000 (1.50)	1500 (2.00)
Operating weight	kg (lb)	1215 (2679)	1575 (3472)	1615 (3560)	1660 (3660)	2390 (5269)	2410 (5313)
Maximum lift capacity	kg (lb)	4000 (8818)	8000 (17,637)	8000 (17,637)	8000 (17,637)	12 000 (26,455)	12 000 (26,455)
Dimensions							
A Height — tines closed*	mm (in)	1740 (68.50)	1720 (67.72)	1860 (73.23)	2010 (79.13)	2175 (85.63)	2265 (89.17)
B Height — tines open*	mm (in)	1385 (54.53)	1440 (56.69)	1510 (59.45)	1590 (62.60)	1830 (72.05)	1880 (72.36)
C Diameter — tines closed	mm (in)	1540 (60.63)	1735 (68.31)	1735 (68.31)	1735 (68.31)	2050 (80.71)	2050 (80.71)
D Diameter — tines open	mm (in)	2415 (95.08)	2390 (94.09)	2595 (101.97)	2855 (102.40)	2950 (116.14)	3050 (120.08)

*Includes hydraulic rotator, excludes machine link.

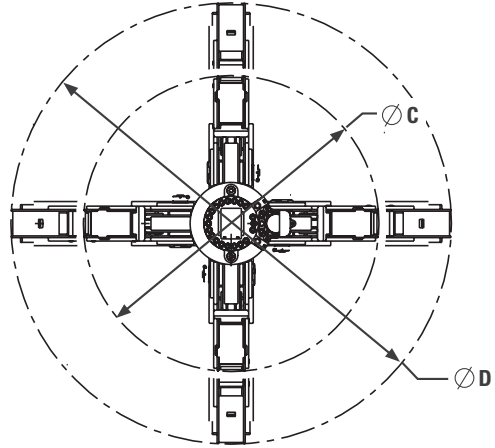
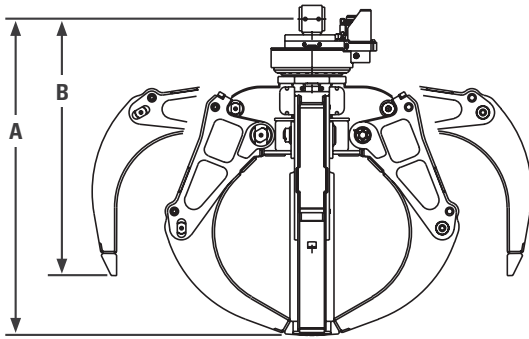

Model		GSH15B	GSH20B		GSH22B		
Part number		293-3202	292-6768	292-7730	292-7743	259-9691	259-9704
Dimensions							
Ground clearance — tines open	mm (in)	640 (25.20)	645 (25.40)	715 (28.15)	790 (31.10)	900 (35.43)	955 (37.60)
Pin diameter	mm (in)	70 (2.76)	80 (3.15)	80 (3.15)	80 (3.15)	90 (3.54)	90 (3.54)
Width of crosshead	mm (in)	114 (4.49)	150 (5.91)	150 (5.91)	150 (5.91)	200 (7.87)	200 (7.87)
Overall width	mm (in)	1810 (71.26)	1800 (70.87)	1930 (75.98)	2125 (83.66)	2230 (87.80)	2320 (91.34)
Maximum opening	mm (in)	2121 (83.50)	2064 (81.26)	2305 (90.75)	2552 (100.47)	2522 (99.29)	2675 (105.31)
Hydraulic Open/Close							
Maximum pressure	bar (psi)	350 (5076)	350 (5076)	350 (5076)	350 (5076)	350 (5076)	350 (5076)
Optimum flow	L/min (gpm)	100 (26.42)	150 (39.63)	150 (39.63)	150 (39.63)	200 (52.83)	200 (52.83)
Hydraulic Rotation							
Maximum pressure	bar (psi)	180 (2610)	200 (2900)	200 (2900)	200 (2900)	200 (2900)	200 (2900)
Optimum pressure	bar (psi)	140 (2030)	160 (2320)	160 (2320)	160 (2320)	160 (2320)	160 (2320)
Optimum flow	L/min (gpm)	20 (5.28)	20 (5.28)	20 (5.28)	20 (5.28)	20 (5.28)	20 (5.28)

Matching Guide

	Boom Length		Stick Length		GSH15B	GSH20B			GSH22B	
	m	(ft/in)	m	(ft/in)	0.57 m ³ (0.75 yd ³)	0.57 m ³ (0.75 yd ³)	0.76 m ³ (1.00 yd ³)	0.96 m ³ (1.25 yd ³)	1.15 m ³ (1.50 yd ³)	1.53 m ³ (2.00 yd ³)
M318C MH	6.2	(20'3")	4.9	(16'1")	X					
M318D MH	6.2	(20'3")	4.9	(16'1")	X					
M322C MH	6.8	(22'3")	4.9	(16'1")	X	+	+	+		
			5.9	(19'4")	-	-	X			
M322D MH	6.8	(22'4")	4.9	(16'1")	X	+	+	+		
			5.9	(19'4")	-	-	X			
M325C MH	8.9	(29'0")	6.0	(19'8")		-	X	+		
			7.4	(24'4")		X				
M325C L MH	8.9	(29'0")	6.0	(19'8")		-	X	+		
			7.4	(24'4")		-	X			
M325D MH	8.9	(29'0")	6.0	(19'8")		-	X	+		
			7.4	(24'4")		X				
M325D L MH	8.9	(29'0")	6.0	(19'8")		-	-	X	+	
			7.4	(24'4")		-	X			
320C MH	6.7	(21'10")	5.5	(17'11")	X					
325C MH	8.4	(27'5")	5.5	(17'11")		-	X			
	8.85	(29'0")	6.0	(19'8")		X				
325D MH	8.85	(29'0")	6.0	(19'8")		-	X			
			7.4	(24'4")		X				
330C MH	9.1	(29'10")	6.0	(19'8")		-	X			
330D MH	9.2	(30'2")	6.1	(20'0")		-	-	-	X	
			7.6	(24'11")		-	-	X		
W345C MH	9.9	(32'6")	7.4	(24'4")					-	X
			9.1	(29'10")					-	X
345C MH	9.9	(32'6")	7.4	(24'4")					-	X
			9.1	(29'10")					X	

- X Primary match for good stability in average scrap handling situations. Considers a material density in the 1200 kg/m³ (2000 lb/yd³) range.
- + Secondary match for **less** dense material.
- Secondary match for **more** dense material.

Guarding Recommendation

Orange Peel Grapples used in hazardous applications like scrap and material handling can create a need for special operator guarding due to flying objects. When using an Orange Peel Grapple, additional protective

devices such as a front screen, Falling Object Guarding System (FOGS, includes top and front guarding), thick polycarbonate windshields or a combination of these is recommended by Caterpillar. Contact your Cat dealer for operator guarding options on your machine.

Features:

- Suitable for a wide range of applications.
- Maximum component protection; lower operating cost.
- Low profile.
- High stability.
- Protected hydraulics.
- Connection lines protection guard.
- Tines constructed of high-strength wear resistant steel.
- Continuous, bi-directional 360° hydraulic rotator.
- Pressure limiting valve for opening and closing.
- Heavy-duty, cushioned cylinders with swing bearings on both sides.
- Maintenance covers for easy access to all maintenance points.
- Weld-on replaceable tips.
- High commonality of parts between 5 and 4 tine configurations.
- Hardened steel-alloy pins.
- High closing force.
- Excellent material penetration.
- Superior lifting capacity.

Selection by Application

Grapple Application		4 Tines				5 Tines			
		O	S	C	N	O	S	C	N
Handling Scrap, Iron and Steel	Small-sized pieces (shredded)	x				x			
	Large-sized pieces up to 1000 × 1000 mm (39" × 39") (steel scrap, wrought iron, white goods, motor blocks)								
	Heavy/long-sized pieces (I-beams, pipes, plates)			x				x	
	Car bodies			x				x	
Handling Nonferrous Scrap Metals	Small-sized pieces (beverage cans, electric devices)	x				x			
	Large-sized pieces (car radiators, batteries)								
	Wires and cables (copper, lead)								
Other Nonferrous Materials	Waste								
	Rocks, concrete blocks			x				x	

Very good
 Good
 x Not Recommended
 O Open
 S Semi-closed
 C Closed
 N Narrow

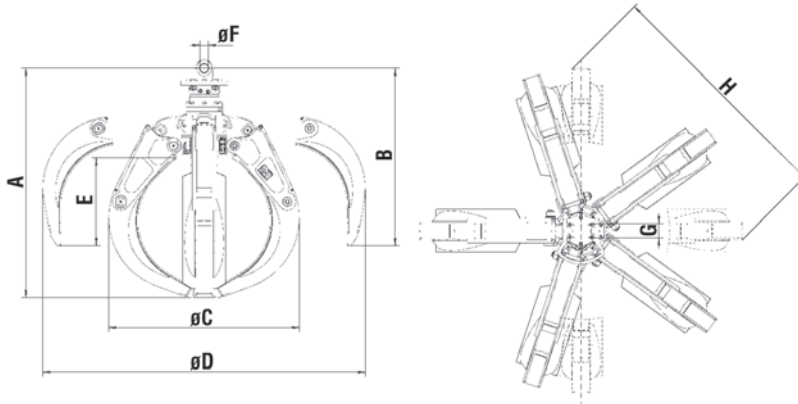

Specifications (All dimensions and weights are approximate.)

Model	GSH15B		GSH15B		GSH15B		GSH15B	
Type	400		500		600		800	
Recommended carrier weight:								
Excavator	15-21 mt	16.5-23.1 st	15-21 mt	16.5-23.1 st	15-21 mt	16.5-23.1 st	15-21 mt	16.5-23.1 st
Material Handler	18-25 mt	19.8-27.6 st	18-25 mt	19.8-27.6 st	18-25 mt	19.8-27.6 st	18-25 mt	19.8-27.6 st
Capacity	0.4 m ³	1.0 yd³	0.5 m ³	1.0 yd³	0.6 m ³	0.75 yd³	0.8 m ³	1.0 yd³
5 Tines								
Operating weight:								
open	1375 kg	3027 lb	1380 kg	3043 lb	1395 kg	3076 lb	1465 kg	3230 lb
semi-closed	1445 kg	3186 lb	1455 kg	3208 lb	1475 kg	3252 lb	1545 kg	3407 lb
closed	1530 kg	3374 lb	1540 kg	3411 lb	1575 kg	3473 lb	1655 kg	3655 lb
narrow	—	—	—	—	1450 kg	3386 lb	1515 kg	3341 lb
4 Tines								
Operating weight:								
open	1155 kg	2538 lb	1160 kg	2558 lb	1175 kg	2591 lb	1210 kg	2668 lb
semi-closed	1225 kg	2701 lb	1235 kg	2723 lb	1250 kg	2756 lb	1300 kg	2867 lb
closed	1355 kg	2988 lb	1375 kg	3032 lb	1410 kg	3109 lb	1495 kg	3296 lb
narrow	—	—	—	—	1215 kg	2679 lb	1260 kg	2778 lb
Dimensions:								
A	1670 mm	66"	1700 mm	67"	1760 mm	69"	1890 mm	74"
B	1350 mm	53"	1370 mm	54"	1400 mm	55"	1460 mm	57"
C	1500 mm	59"	1500 mm	59"	1500 mm	59"	1500 mm	59"
D	2190 mm	86"	2250 mm	89"	2340 mm	92"	2550 mm	100"
E	600 mm	24"	620 mm	24"	650 mm	26"	710 mm	28"
F	70 mm	3"	70 mm	3"	70 mm	3"	70 mm	3"
G	114 mm	4"	114 mm	4"	114 mm	4"	114 mm	4"
H	1440 mm	57"	1480 mm	58"	1540 mm	57"	1670 mm	66"
I	2085 mm	82"	2145 mm	84"	2230 mm	88"	2430 mm	96"
H (4 tines)	1700 mm	67"	1740 mm	69"	1810 mm	71"	1970 mm	78"
Hydraulic open/close:								
Maximum pressure	350 bar	5075 psi	350 bar	5075 psi	350 bar	5075 psi	350 bar	5075 psi
Optimum flow	100 L/min	26 gpm	100 L/min	26 gpm	100 L/min	26 gpm	100 L/min	26 gpm
Hydraulic rotation:								
Maximum pressure	140 bar	2030 psi	140 bar	2030 psi	140 bar	2030 psi	140 bar	2030 psi
Optimum flow	20 L/min	5 gpm	20 L/min	5 gpm	20 L/min	5 gpm	20 L/min	5 gpm

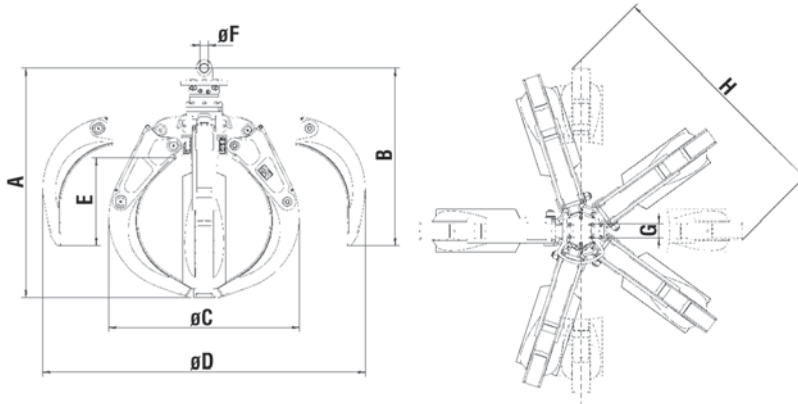

Specifications (All dimensions and weights are approximate.)

Model	GSH20B		GSH20B		GSH20B	
Type	600		800		1000	
Recommended carrier weight:						
Excavator	20-30 mt	22-33.1 st	20-30 mt	22-33.1 st	20-30 mt	22-33.1 st
Material Handler	25-35 mt	27.6-49.6 st	25-35 mt	27.6-49.6 st	25-35 mt	27.6-49.6 st
Capacity	0.6 m ³	0.75 yd³	0.8 m ³	1.0 yd³	1.0 m ³	1.25 yd³
5 Tines						
Operating weight:						
open	1820 kg	4013 lb	1855 kg	4090 lb	1900 kg	4190 lb
semi-closed	1905 kg	4201 lb	1955 kg	4311 lb	2020 kg	4454 lb
closed	1985 kg	4377 lb	2055 kg	4531 lb	2145 kg	4730 lb
narrow	1870 kg	4123 lb	1920 kg	4234 lb	1975 kg	4355 lb
4 Tines						
Operating weight:						
open	1545 kg	3407 lb	1570 kg	3462 lb	1605 kg	3539 lb
semi-closed	1615 kg	3561 lb	1655 kg	3649 lb	1705 kg	3760 lb
closed	1745 kg	3848 lb	1820 kg	4013 lb	1910 kg	4212 lb
narrow	1575 kg	3473 lb	1615 kg	3561 lb	1660 kg	3660 lb
Dimensions:						
A	1720 mm	68"	1860 mm	73"	2010 mm	79"
B	1440 mm	57"	1510 mm	59"	1590 mm	63"
C	1735 mm	68"	1735 mm	68"	1735 mm	68"
D	2390 mm	94"	2595 mm	102"	2855 mm	112"
E	645 mm	25"	715 mm	28"	790 mm	31"
F	80 mm	3"	80 mm	3"	80 mm	3"
G	150 mm	6"	150 mm	6"	150 mm	6"
H	1530 mm	60"	1640 mm	65"	1800 mm	71"
I	2210 mm	87"	2395 mm	94"	2635 mm	104"
H (4 tines)	1800 mm	71"	1930 mm	76"	2125 mm	84"
Hydraulic open/close:						
Maximum pressure	350 bar	5075 psi	350 bar	5075 psi	350 bar	5075 psi
Optimum flow	150 L/min	40 gpm	150 L/min	40 gpm	150 L/min	40 gpm
Hydraulic rotation:						
Maximum pressure	200 bar	2900 psi	200 bar	2900 psi	200 bar	2900 psi
Optimum flow	20 L/min	5 gpm	20 L/min	5 gpm	20 L/min	5 gpm

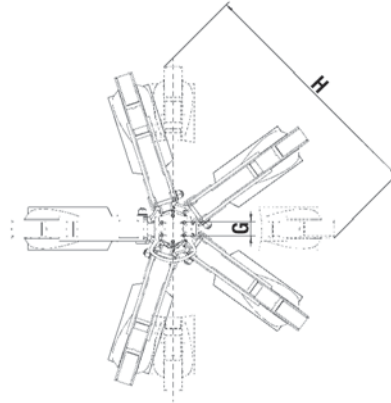
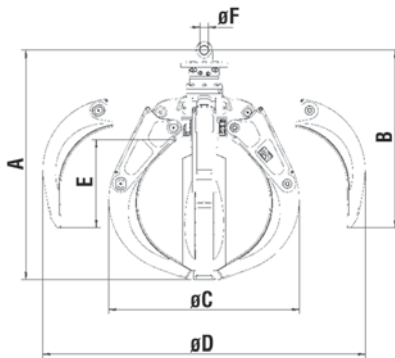

Specifications (All dimensions and weights are approximate.)

Model	GSH22B 600		GSH22B 800		GSH22B 1000	
Type						
Recommended carrier weight:						
Excavator	22-50 mt	24.3-55.1 st	22-50 mt	24.3-55.1 st	22-50 mt	24.3-55.1 st
Material Handler	35-60 mt	38.6-66.1 st	35-60 mt	38.6-66.1 st	35-60 mt	38.6-66.1 st
Capacity	0.6 m ³	0.75 yd³	0.8 m ³	1.0 yd³	1.0 m ³	1.25 yd³
5 Tines						
Operating weight:						
open	2660 kg	5865 lb	2715 kg	4796 lb	2740 kg	6042 lb
semi-closed	2770 kg	6108 lb	2855 kg	6295 lb	2890 kg	6372 lb
closed	2860 kg	6306 lb	2980 kg	6571 lb	3030 kg	6681 lb
narrow	—	—	—	—	2855 kg	6295 lb
4 Tines						
Operating weight:						
open	2255 kg	4972 lb	2295 kg	5060 lb	2315 kg	5105 lb
semi-closed	2350 kg	5182 lb	2415 kg	5325 lb	2440 kg	5380 lb
closed	2530 kg	5696 lb	2650 kg	5843 lb	2700 kg	5954 lb
narrow	—	—	—	—	2390 kg	5270 lb
Dimensions:						
A	1970 mm	70"	2100 mm	83"	2175 mm	86"
B	1710 mm	67"	1785 mm	70"	1830 mm	72"
C	2050 mm	81"	2050 mm	81"	2050 mm	81"
D	2640 mm	104"	2840 mm	112"	2950 mm	116"
E	780 mm	31"	860 mm	34"	900 mm	35"
F	90 mm	4"	90 mm	4"	90 mm	4"
G	200 mm	8"	200 mm	8"	200 mm	8"
H	1530 mm	60"	1840 mm	72"	1900 mm	75"
I	2450 mm	96"	2635 mm	104"	2730 mm	107"
H (4 tines)	2010 mm	79"	2160 mm	85"	2230 mm	88"
Hydraulic open/close:						
Maximum pressure	350 bar	5075 psi	350 bar	5075 psi	350 bar	5075 psi
Optimum flow	200 L/min	53 gpm	200 L/min	53 gpm	200 L/min	53 gpm
Hydraulic rotation:						
Maximum pressure	200 bar	2900 psi	200 bar	2900 psi	200 bar	2900 psi
Optimum flow	20 L/min	5 gpm	20 L/min	5 gpm	20 L/min	5 gpm

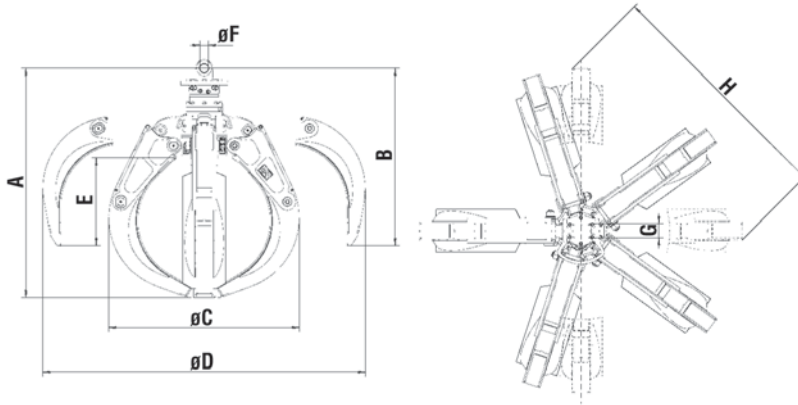

Specifications (All dimensions and weights are approximate.)

Model	GSH22B		GSH22B	
Type	1250		1500	
Recommended carrier weight:				
Excavator	22-50 mt	24.3-55.1 st	22-50 mt	24.3-55.1 st
Material Handler	35-60 mt	38.6-66.1 st	35-60 mt	38.6-66.1 st
Capacity	1.25 m ³	1.65 yd³	1.5 m ³	2.0 yd³
5 Tines				
Operating weight:				
open	2780 kg	6130 lb	—	—
semi-closed	2945 kg	6494 lb	—	—
closed	3095 kg	6813 lb	—	—
narrow	—	—	2880 kg	6350 lb
4 Tines				
Operating weight:				
open	2350 kg	5182 lb	—	—
semi-closed	2485 kg	5479 lb	—	—
closed	2760 kg	6086 lb	—	—
narrow	—	—	2410 kg	5314 lb
Dimensions:				
A	2245 mm	88"	2265 mm	89"
B	1870 mm	74"	1880 mm	74"
C	2085 mm	82"	2050 mm	80"
D	3060 mm	120"	3050 mm	120"
E	940 mm	37"	955 mm	38"
F	90 mm	4"	90 mm	4"
G	200 mm	8"	200 mm	8"
H	1980 mm	78"	1980 mm	78"
I	2830 mm	111"	2820 mm	111"
H (4 tines)	2320 mm	91"	2320 mm	91"
Hydraulic open/close:				
Maximum pressure	350 bar	5075 psi	350 bar	5075 psi
Optimum flow	200 L/min	53 gpm	200 L/min	53 gpm
Hydraulic rotation:				
Maximum pressure	200 bar	2900 psi	200 bar	2900 psi
Optimum flow	20 L/min	5 gpm	20 L/min	5 gpm

Work Tools Matching Guide

Choosing the proper Orange Peel Grapple can increase productivity and lower your cost per ton.

Matching information not available. Please see marketing literature for current matching information.

Multi-Functional Concrete Crushers Europe, Africa, Middle East

Features Guarding Recommendation Matching Guide

Features:

- Multi-functional operation, the crusher combines several demolition operations in one piece of equipment. Breaking out concrete from fixed structures, pulverizing concrete and cutting reinforcement rods and small steel profiles.
- High force-to-weight ratio, the crusher's special cylinder position allows it to maintain the same power with significantly lower weight.
- Enhanced performance, the standard speed valve enables cutting/crushing with great force and in even shorter cycle times.
- Optimized serviceability, the teeth and blades are replaceable and the hydraulics is easy accessible through bolted hatches.

Guarding Recommendation

Multi-Functional Concrete Crushers used in hazardous applications like breaking out concrete from fixed structures, pulverizing concrete and cutting, can create a need for special operator guarding due to flying objects. When using a Multi-Functional Concrete Crusher, additional protective devices such as a front screen, Falling Object Guarding System (FOGS, includes top and front guarding), thick polycarbonate windshields or a combination of these is recommended by Caterpillar. Contact your Cat dealer for operator guarding options on your machine.

Matching Guide

Multi-Functional Concrete Crushers

Model	Cat Excavator
P315	315C/D, 318C, 319C/D, 320B/C/D, 322B/C, 323D, 324D, 325B/C, 325UHD C/D, 330UHD B/C/D, 345UHD B/C, 385UHD B/C
P325	320D, 322B/C, 324D, 325B/C/D, 329D, 330B/C/D, 336D, 325UHD C/D, 330UHD B/C/D, 345UHD C, 365UHD B/C, 385UHD B/C
P335	325B/C/D, 329D, 330B/C/D, 336D, 345B/C, 365UHD BII/C, 385 UHD B/C
P360	345B/C, 365B/C, 385B/C

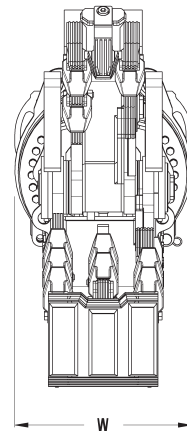
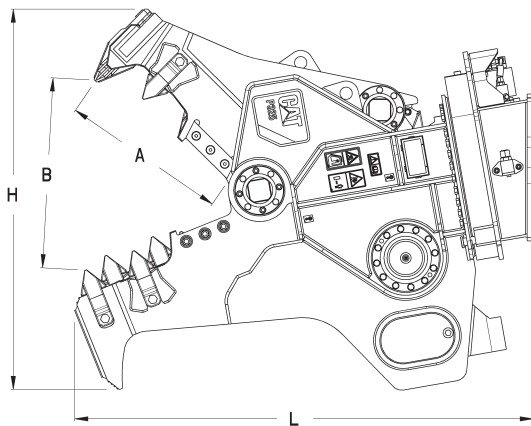

Specifications and Dimensions

Model	P315		P325		P335		P360	
Recommended carrier weight, stick mounted	15-25		25-35		35-60		60-85	
Weight* (approximate)	1890 kg	4170 lb	2550 kg	5620 lb	3550 kg	7825 lb	5230 kg	11,530 lb
Closing force:								
at tooth tip	90 mt	99 st	125 mt	138 st	160 mt	176 st	210 mt	231 st
at primary cutter	190 mt	210 st	295 mt	325 st	355 mt	391 st	455 mt	501 st
Dimensions:								
(L) Length	1927 mm	76"	2060 mm	81"	2398 mm	130"	2737 mm	108"
(H) Height	1543 mm	61"	1710 mm	67"	1897 mm	75"	2312 mm	91"
(W) Width	793 mm	31"	793 mm	31"	750 mm	30"	1180 mm	46"
(A) Jaw depth	657 mm	26"	753 mm	30"	877 mm	35"	933 mm	37"
(B) Jaw opening	731 mm	29"	855 mm	34"	983 mm	39"	1201 mm	47"
Cutter length	200 mm	8"	260 mm	10"	350 mm	14"	350 mm	14"
Maximum pressure:								
Crushing circuit	350 bar	5076 psi	350 bar	5076 psi	350 bar	5076 psi	350 bar	5076 psi
Rotation	140 bar	2030 psi	140 bar	2030 psi	140 bar	2030 psi	140 bar	2030 psi
Optimum flow:								
Crushing circuit	150 L/min	40 gpm	200 L/min	53 gpm	300 L/min	79 gpm	400 L/min	105 gpm
Rotation	40 L/min	11 gpm	40 L/min	11 gpm	40 L/min	11 gpm	80 L/min	21 gpm
Time to close	2 sec		2 sec		2.5 sec		3 sec	
Time to open	3 sec		4 sec		4 sec		4 sec	
Crushing capacity:								
Concrete thickness**	550 mm	22"	650 mm	26"	800 mm	31"	950 mm	37"

*Weight excludes mounting bracket.

**The concrete thickness as published provides an indication of crushing ability. The exact crushing ability depends on proper excavator adjustment, on the tip and amount of rebar, and on the condition of the concrete, jaws and crushers.

Features:

- **Ideal for pulverizing from non fixed structures** — The Secondary Pulverizer is an excellent choice for all those recyclers who need to prepare concrete for fine crushing and is an excellent attachment for secondary demolition. Concrete chunks released during the demolition of concrete structures can be fine-crushed at source. In this process the concrete and the reinforcement are separated. This considerably reduces the transport volume, saving dumping and transportation expenses.
- **Innovative jaw arrangement** — The Cat Secondary Pulverizer offers wide jaws with pick-up tips, large opening, reversible cutting edges and fast closing times that bring a high return on your investment. This high force-to-weight work tool has been specially developed to reduce the largest possible amount of concrete in the shortest possible time.
- **Enhanced performance** — The ripper tooth splits concrete instantly and the large number of teeth have a large pulverizing effect. The cylinder of the pulverizer is equipped with a speed valve as standard. This device controls the speed of the cylinder and enables to cut/crush with great force in short cycle times.
- **Optimized serviceability** — Service and repairs are a necessary part of operating any work tool. So the less time and money needed for both, the better. That's why Caterpillar gives major attention to reducing both. The teeth and blades are replaceable and the hydraulics are easily accessible through bolted hatches. Parts commonality is designed into Cat products to significantly benefit owners of several work tools.
- **Long lifetime** — Cat Work Tools are designed to last long. Precision machined and forged parts, wear protection and stress relieving plates as well as fully protected hydraulic cylinder provide a long lifetime of low cost production.

Guarding Recommendation

Hydraulic Concrete Pulverizers are used in hazardous applications like breaking out concrete from fixed structures, pulverizing concrete and cutting; creating a need for special operator guarding due to flying objects. When using these tools, additional protective devices such as a front screen, Falling Object Guarding System (FOGS, includes top and front guarding), thick polycarbonate windshields or a combination of these is recommended by Caterpillar. Contact your Cat dealer for operator guarding options on your machine.

Matching Guide

Hydraulic Concrete Pulverizers

Model	Cat Excavator
P215	315C/D, 318C, 319C/D, 320B/C/D, 322B/C, 323D, 324D, 325B/C/D
P225	320D, 322B/C, 324D, 325B/C/D, 329D, 330B/C/D, 336D
P235	325B/C/D, 329D, 330B/C/D, 336D, 345B/C

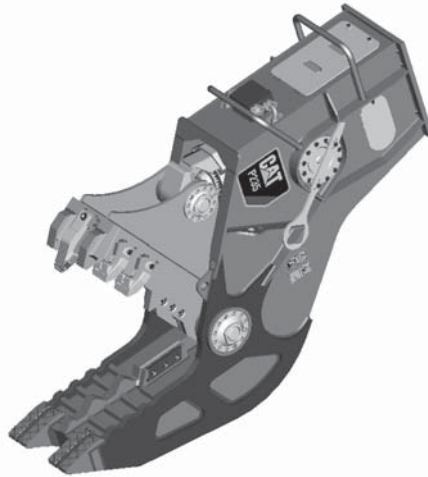

Specifications and Dimensions

Model	P215		P225		P235	
Recommended carrier weight***:						
Stick mounted	15-25		25-35		35-60	
Weight* (approximate)	1683 kg	3710 lb	2480 kg	5467 lb	3421 kg	7542 lb
Closing force:						
at tooth tip	121 mt	133 st	177 mt	195 st	94 mt	104 st
at primary cutter	235 mt	259 st	338 mt	373 st	401 mt	442 st
Dimensions:						
Length	2414 mm	95"	2615 mm	103"	3046 mm	120"
Height	1372 mm	54"	1645 mm	65"	1918 mm	76"
Width	580 mm	23"	624 mm	25"	708 mm	28"
Jaw depth	722 mm	28"	899 mm	35"	1103 mm	43"
Jaw opening	838 mm	33"	1018 mm	40"	1214 mm	48"
Cutter length	200 mm	8"	260 mm	10"	260 mm	10"
Maximum pressure crushing/ cutting	350 bar	5076 psi	350 bar	5076 psi	350 bar	5076 psi
Optimum flow crushing/cutting	150 L/min	40 gpm	200 L/min	53 gpm	300 L/min	79 gpm
Return flow	240 L/min	63 gpm	300 L/min	79 gpm	510 L/min	135 gpm
Time to close	3 sec		3 sec		3.5 sec	
Time to open	4 sec		5 sec		4.5 sec	
Crushing capacity:						
Concrete thickness**	650 mm	26"	750 mm	30"	900 mm	35"

*Weight excludes mounting bracket.

**The concrete thickness provides an indication of the crushing capacity. The exact crushing capability depends on excavator operation pressure and performance, on the tip and amount of rebar, and the condition of the concrete, jaws and cutters.

***The P200 work tool can also be installed on non-Cat carriers in the listed weight classes by installing a mounting bracket with the right pin-on ears, or with hinges to fit the dedicated CW quick coupler.

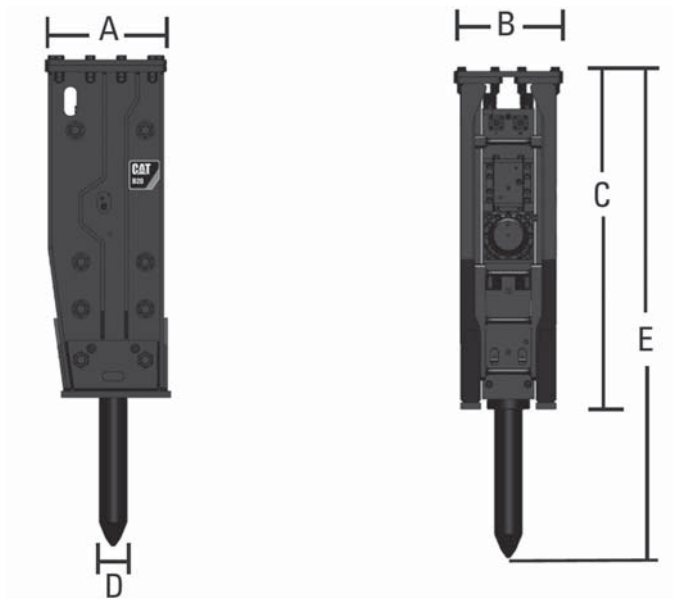

Specifications – Top-mount Style

Model	B8		B20		B30		B35	
Recommended carrier weight (minimum)	6 m tons	6.6 tons	17 m tons	18.7 tons	25 m tons	27.6 tons	30 m tons	33.1 tons
Recommended carrier weight (maximum)	9 m tons	9.9 tons	27 m tons	30 tons	32 m tons	35.3 tons	40 m tons	44.1 tons
Working weight*	438 kg	966 lb	1620 kg	3571 lb	2209 kg/ 2228 kg**	4870 lb/ 4912 lb**	3005 kg	6625 lb
Impact frequency	460-750 bpm		400-800 bpm		350-700 bpm		250-550 bpm	
Acceptable oil flow	45- 85 L/min	12- 22 gpm	125- 150 L/min	33- 40 gpm	160- 190 L/min	42- 50 gpm	180- 220 L/min	48- 58 gpm
Operating pressure	95- 130 bar	1378- 1885 psi	160- 180 bar	2321- 2611 psi	160- 180 bar	2321- 2611 psi	160- 180 bar	2321- 2611 psi
Dimensions:								
A Length	460 mm	18.1"	632 mm	24.9"	655 mm	25.8"	730 mm	28.7"
B Width	346 mm	13.6"	525 mm	20.7"	585 mm	23.0"	635 mm	25.0"
C Height (breaker)	877 mm	34.5"	1634 mm	64.3"	1829 mm	72.0"	1995 mm	78.5"
D Tool diameter	74.5 mm	2.9"	135 mm	5.3"	150 mm	5.9"	153 mm	6.0"
E Tool working length	1481 mm	58.3"	2389 mm	94.1"	2632 mm	103.6"	2798 mm	110.2"

*Working weight includes brackets andmoil tool.

**CB linkage – 2009 kg (4429 lb), DB linkage – 2228 kg (4912 lb).

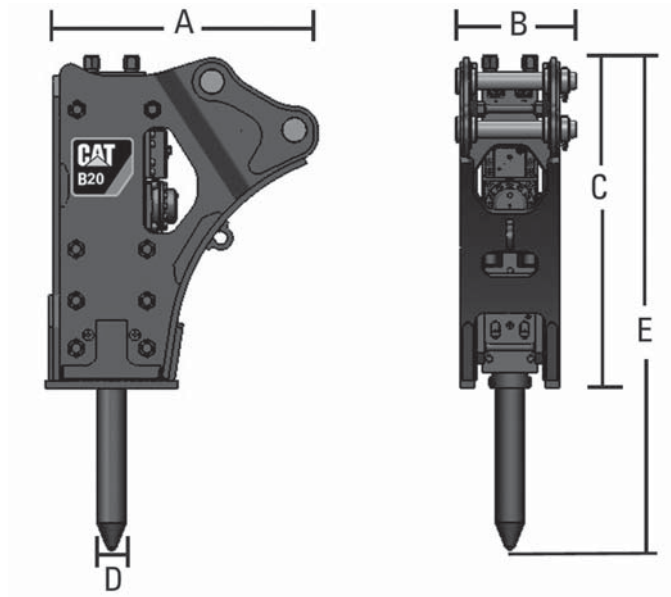

Specifications – Side-mount Style

Model	B20				B30					
Recommended carrier weight (minimum)	17 m tons		18.7 tons		25 m tons		27.6 tons			
Recommended carrier weight (maximum)	27 m tons		29.8 tons		32 m tons		35.3 tons			
Working weight*	1620 kg		3571 lb		2047 kg		4513 lb			
Impact frequency	400-800 bpm				350-700 bpm					
Acceptable oil flow	125-150 L/min		33-40 gpm		160-190 L/min		42-50 gpm			
Operating pressure	160-180 bar		2321-2611 psi		160-180 bar		2321-2611 psi			
Linkage:	B/B1		CB/CB2		DB		CB/CB2		DB	
Dimensions:										
A Length – top	1270 mm	50"	1302 mm	51.3"	1327 mm	52.2"	1367 mm	53.8"	1367 mm	53.8"
A Length – bottom	620 mm	24.4"	620 mm	24.4"	620 mm	24.4"	650 mm	25.6"	650 mm	25.6"
B Width	457 mm	18"	457 mm	18"	457 mm	18"	524 mm	20.6"	524 mm	20.6"
C Height (breaker)	1539 mm	60.6"	1539 mm	60.6"	1549 mm	60.6"	1725 mm	67.9"	1732 mm	68.2"
D Tool diameter	135 mm	5.3"	135 mm	5.3"	135 mm	5.3"	150 mm	5.9"	150 mm	5.9"
E Tool working length	2294 mm	90.3"	2294 mm	90.3"	2294 mm	90.3"	2530 mm	99.6"	2537 mm	99.9"

*Working weight includes brackets andmoil tool.

Machine Compatibility

Auto-Connect Quick Coupler

Model	Linkage Hydraulic	Excavators
CWAC-40	—	M315D/M316D
CWAC-40	—	M318D/M322D
CWAC-40	—	315D/316E/318E
CWAC-40	—	319D
CWAC-40	B	320D/320E/321D/ 323D/323E

Auto-Connect is fast, fail-safe and reliable, and eliminates the oil spillages common with manual connections. Its design allows for high flows at low back pressures to ensure tools are used most effectively and to maintain optimum performance and matching. The design also ensures a perfect connection by balancing the connecting forces evenly across hoses. And the working pressure of the fluid maintains that connection even more securely.

Auto-Connect automatically connects up to five hydraulic ports (two high pressure and an optional drain) that typically need to be connected and disconnected by hand. That shortens the time for exchanging a hydraulic work tool from around half an hour to just a few seconds. Cutting out manual intervention also avoids potential spillage of hydraulic oil into the environment.

MATERIAL HANDLERS

CONTENTS

M322D2 MH, M324D2 MH	
Range Dimensions	9-2
M322D2 MH Lifting Capacities	9-3
M324D2 MH Lifting Capacities	9-7
M325D MH, M325D LMH	
Dimensions	9-15
Range Dimensions	9-17
Lifting Capacities	9-18
MH3022	
Specifications	9-28
Range Dimensions	9-29
Lifting Capacities	9-31
MH3024	
Specifications	9-47
Range Dimensions	9-47
Lifting Capacities	9-48
MH3037	
Range Diagram and Specifications	9-88
Lifting Capacities	9-89
MH3049	
Range Diagram and Specifications	9-91
Lifting Capacities	9-92
MH3059	
Range Diagram and Specifications	9-93
Lifting Capacities	9-94
385C MH	
Range Diagrams and Specifications	9-95
Lifting Capacities	9-96
Magnet Selection	9-98
Grapple Selection	9-98
Ferrous Scrap Specifications	9-99

(Scrap specifications and classifications can be found in the Institute of Scrap Iron and Steel Inc.'s "Handbook." The common unit measure for the scrap industry is the gross ton which is 2240 pounds. However, short tons, net tons and metric tons may also be used.)

The versatility of Cat® material handlers, plus their ability to be equipped in any number of ways, make them an effective, low cost way to handle scrap and other materials.

NOTE: Contact your Cat dealer for additional information on equipping Cat Material Handlers for scrap or bulk material handling applications.

M322D2 MH & M324D2 MH Range Diagram

● Cat Material Handling Boom and MH Stick

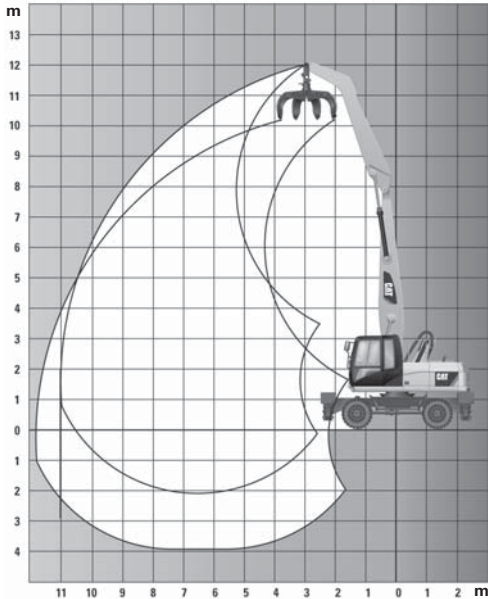

Model	M322D2 MH		M324D2 MH			
	m	ft	m	ft	m	ft
Boom	6.4	21'0"	6.8	22'3"	6.8	22'3"
Stick	4.9	16'1"	4.9	16'1"	5.9	19'4"
Maximum Horizontal Reach	11.0	36'1"	11.5	37'7"	12.5	41'0"
Maximum Vertical Pin Height	12.1	39'7"	12.5	41'0"	13.3	43'6"

Lifting Capacities

Equipped with Cat material handling arrangement. Capacities are measured at the bare stick tip.

Capacities are based on level machine equipped as follows:

- Total machine weight including base machine, material handling front, cab riser, heavy duty axles, two sets of outriggers, lubricants, full fuel tank and operator.
 M322D2 MH — 19 150-22 350 kg (42,218-49,273 lb)
 M324D2 MH — 20 400-24 600 kg (44,974-54,233 lb)

M322D2 MH & M324D2 MH Range Diagram

● Cat Material Handling Boom and Straight Stick

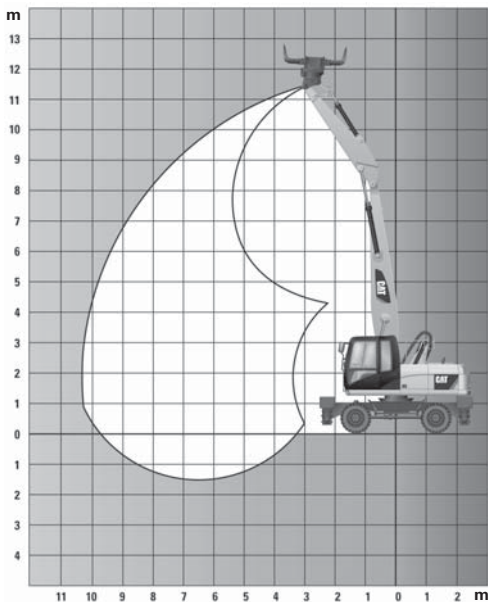

Model	M322D2 MH		M324D2 MH	
	m	ft	m	ft
Boom	6.4	21'0"	6.8	22'3"
Stick	4.2	13'8"	4.8	15'7"
Maximum Horizontal Reach	10.3	33'8"	11.4	37'4"
Maximum Vertical Pin Height	11.5	37'7"	12.4	40'7"

Lift Capacities

All values are in kg, without bucket and without QC, with counterweight (4000 kg/8818 lb), heavy lift on.



Undercarriage		Boom 6400 mm (21'0")						Stick 4900 mm (16'1")						Metric Units				
Standard		3.0 m		4.5 m		6.0 m		7.5 m		9.0 m		10.5 m		m				
Lift height	Undercarriage configuration	Load point height	Load over front	Load over rear	Load over side	Load at maximum reach	Load point height	Load over front	Load over rear	Load over side	Load at maximum reach	Load point height	Load over front	Load over rear	Load over side	Load at maximum reach		
		10.5 m	Rear dozer up Rear dozer down Dozer and stab down						5800	4700	3950						4800	3850
								*6500	4450							*5250	3700	
								*6500	6450							*5250	*5250	
9.0 m	Rear dozer up Rear dozer down Dozer and stab down						5900	4800	4100	4100	3300	2800				3450	2750	2300
								*7850	4600							*4700	2600	
								*7850	6600							*4700	3850	
7.5 m	Rear dozer up Rear dozer down Dozer and stab down						5900	4800	4100	4150	3300	2850	3050	2400	2050	2800	2200	1850
								*8200	4600							*4400	2100	
								*8200	6600							*4400	3150	
6.0 m	Rear dozer up Rear dozer down Dozer and stab down						5800	4700	3950	4050	3250	2750	3050	2400	2050	2450	1900	1600
								*8450	4450							3900	1850	
								*8450	6450							*4300	2750	
4.5 m	Rear dozer up Rear dozer down Dozer and stab down						8850	7100	5900	5600	4500	3800	3950	3150	2650	2950	2350	1950
								*11 200	6700							4750	2250	
								*11 200	10 000							4200	2600	
								*8900	6250							5350	3350	
3.0 m	Rear dozer up Rear dozer down Dozer and stab down	16 850	12 800	9950	8250	6500	5350	5300	4200	3500	3800	3000	2500	2900	2250	1900	2250	1750
			*18 650	11 750	*12 400	6150	9000	9000	4000							6200	2850	
			*18 650	*18 650	*12 400	9350	*9400	5950								6950	4250	
1.5 m	Rear dozer up Rear dozer down Dozer and stab down					7600	5900	4800	5000	3900	3250	3650	2850	2350	2800	2150	1800	2250
							*13 100	5550								6000	2700	
							*13 100	8700								6800	4100	
0.0 m	Rear dozer up Rear dozer down Dozer and stab down	*3500	*3500	*3500	7200	5450	4400	4750	3650	3000	3500	2700	2250	2700	2100	1750	2200	1700
			*3500	*3500		*12 200	5150		8350	3500					4450	2000		
			*3500	*3500		*12 200	8250		*9250	5400					5050	3050		
-1.5 m	Rear dozer up Rear dozer down Dozer and stab down					7000	5300	4200	4600	3550	2900	3400	2600	2150	2650	2050	1700	1400
							*9600	4950								4400	1950	
							*9600	8050								*4750	3000	

9

Undercarriage
Special Application

Boom
6400 mm (21'0")

Stick
4900 mm (16'1")

Lift height	Undercarriage configuration	3.0 m		4.5 m		6.0 m		7.5 m		9.0 m		10.5 m		m			
		Load point height	Load over front	Load over rear	Load over side	Load at maximum reach	Load point height	Load over front	Load over rear	Load over side	Load at maximum reach	Load point height	Load over front	Load over rear	Load over side	Load at maximum reach	
10.5 m	All stabilizers up All stabilizers down							5750	4350						4800	3650	
								*6500	*6500						*5250	*5250	
9.0 m	All stabilizers up All stabilizers down							5900	4500	4100	3100				3450	2600	
								*7850	*7850	*6300	*6300				*4700	*4700	
7.5 m	All stabilizers up All stabilizers down							5900	4500	4150	3150	3050	2300		2800	2100	
								*8200	*8200	*7100	6450	*5500	4800		*4400	*4400	
6.0 m	All stabilizers up All stabilizers down							5800	4400	4100	3100	3050	2300		2450	1800	
								*8450	*8450	*7200	6400	5850	4750		*4300	3900	
4.5 m	All stabilizers up All stabilizers down							8750	6500	5550	4200	3950	2950	3000	2200	2350	1700
								*11 200	*11 200	*8900	*8900	*7400	6250	5800	4700	4550	3700
3.0 m	All stabilizers up All stabilizers down	16 300	11 000	8150	5950	5300	3900	3800	2850	2900	2150	2300	1700	2150	1550	1550	
		*18 650	*18 650	*12 400	*12 400	*9400	8650	*7600	6100	5700	4600	4500	3650	4250	3450	3600	
1.5 m	All stabilizers up All stabilizers down							7550	5350	5000	3650	3650	2650	2800	2050	2250	1650
								*13 100	*13 100	*9650	8300	7400	5900	5600	4500	4450	3600
0.0 m	All stabilizers up All stabilizers down	*3500	*3500	7100	4950	4750	3400	3500	2550	2750	2000	2200	1600				
		*3500	*3500	*12 200	*12 200	*9250	8050	*7200	5750	5500	4450	*4100	3600				
-1.5 m	All stabilizers up All stabilizers down							6900	4800	4600	3300	3400	2450	2700	1950		
								*9600	*9600	*8100	7900	*6300	5650	*4750	4400		

*Limited by hydraulic rather than tipping load.

Lift capacity ratings are based on ISO 10567:2007, they do not exceed 87% of hydraulic lifting capacity or 75% of tipping load. The load point is the center line of the bucket pivot mounting pin on the stick. The oscillating axle must be locked. Lifting capacities are based on the machine standing on a firm uniform supporting surface. For lifting capacity including bucket and/or quick coupler, the respective weight has to be subtracted from above values. The use of a work tool attachment point to handle/lift objects, could affect the machine lift performance.

Always refer to the appropriate Operation and Maintenance Manual for specific product information.

Lift Capacities

All values are in lb, without bucket and without QC, with counterweight (4000 kg/8818 lb), heavy lift on.



Undercarriage		Boom						Stick						English Units										
Standard		6400 mm (21'0")						4900 mm (16'1")																
Undercarriage configuration	10.0 ft			15.0 ft			20.0 ft		25.0 ft		30.0 ft		35.0 ft		ft									
	Load point height	Load over front	Load over rear	Load over front	Load over rear	Load over side	Load over side	Load over side	Load over side	Load over side	Load over side	Load over side	Load at maximum reach (sticknose/bucket pin)											
35.0 ft	Rear dozer up						12,400	10,000	8500						11,200	9000	7600	21.23						
	Rear dozer down							*13,400	9500							*11,800	8600							
	Dozer and stab down							*13,400	*13,400							*11,800	*11,800							
30.0 ft	Rear dozer up						12,700	10,300	8800	8800	7100	6000				7800	6200	5200	26.87					
	Rear dozer down							*17,000	9800							*10,400	5900							
	Dozer and stab down							*17,000	14,200							*10,400	8700							
25.0 ft	Rear dozer up						12,700	10,300	8800	8900	7100	6100	6500	5200	6300	4900	4200	30.64						
	Rear dozer down							*17,900	9900							*9800	4700							
	Dozer and stab down							*17,900	14,200							*9800	7000							
20.0 ft	Rear dozer up						12,500	10,100	8600	8800	7000	6000	6500	5200	5400	4300	3600	33.27						
	Rear dozer down							*18,400	9600							8700	4100							
	Dozer and stab down							*18,400	13,900							*9500	6100							
15.0 ft	Rear dozer up				19,100	15,300	12,700	12,000	9700	8100	8500	6800	5700	6400	5000	4200	3700	34.97						
	Rear dozer down					*24,300	14,500		*19,400	9200					10,200	4800								
	Dozer and stab down					*24,300	21,500		*19,400	13,500					11,500	7200								
10.0 ft	Rear dozer up	36,200	27,500	21,500	17,800	14,000	11,600	11,400	9100	7600	8200	6500	5400	6200	4900	4100	4900	3800	3100	4700	3600	3000	35.89	
	Rear dozer down		*40,200	25,300		*26,900	13,300		19,300	8600		13,300	6200		10,000	4700		7900	3600		7600	3500		
	Dozer and stab down		*40,200	*40,200		*26,900	20,200		*20,400	12,800		15,000	9200		11,300	7000		8900	5500		8600	5300		
5.0 ft	Rear dozer up				16,400	12,700	10,300	10,800	8400	7000	7800	6100	5100	6000	4700	3900	4800	3700	3100	4600	3500	2900		36.09
	Rear dozer down					*28,400	12,000		18,500	8000		12,900	5800		9800	4500		7800	3500		7400	3400		
	Dozer and stab down					*28,400	18,700		20,800	12,200		14,600	8800		11,100	6800		8800	5400		8400	5200		
0.0 ft	Rear dozer up	*8000	*8000	*8000	15,500	11,800	9500	10,300	7900	6500	7500	5800	4800	5900	4500	3700								
	Rear dozer down		*8000	*8000		*27,000	11,100		17,900	7500		12,600	5600		9600	4300								
	Dozer and stab down		*8000	*8000		*27,000	17,700		*20,100	11,600		14,300	8500		10,900	6600								
-5.0 ft	Rear dozer up				15,000	11,400	9100	10,000	7600	6200	7400	5700	4600											
	Rear dozer down					*22,200	10,700		*17,500	7200		12,400	5400											
	Dozer and stab down					*22,200	17,300		*17,500	11,300		*13,500	8300											

Undercarriage
Special Application

Boom
6400 mm (21'0")

Stick
4900 mm (16'1")

Undercarriage configuration	10.0 ft		15.0 ft		20.0 ft		25.0 ft		30.0 ft		35.0 ft		ft				
	Load point height	Load over front	Load over rear	Load over front	Load over rear	Load over side	Load over side	Load over side	Load over side	Load over side	Load over side	Load at maximum reach (sticknose/bucket pin)					
35.0 ft	All stabilizers up						12,300	9300					11,200	8400	21.23		
	All stabilizers down						*13,400	*13,400					*11,800	*11,800			
30.0 ft	All stabilizers up						12,700	9600	8800	6700			7800	5900	26.87		
	All stabilizers down						*17,000	*17,000	*13,100	*13,100			*10,400	*10,400			
25.0 ft	All stabilizers up						12,700	9600	8900	6700	6500	4900	6300	4700	30.64		
	All stabilizers down						*17,900	*17,900	*15,500	13,900	*11,000	10,300	*9800	*9800			
20.0 ft	All stabilizers up						12,500	9400	8800	6600	6500	4900	5500	4100	33.27		
	All stabilizers down						*18,400	*18,400	*15,700	13,700	12,600	10,300	*9500	8700			
15.0 ft	All stabilizers up				18,900	14,000	12,000	9000	8500	6400	6400	4800	5000	3700	34.97		
	All stabilizers down				*24,300	*24,300	*19,400	19,300	*16,100	13,500	12,500	10,100	*9500	8000			
10.0 ft	All stabilizers up	35,000	23,700	17,600	12,800	11,400	8500	8200	6100	6300	4600	4900	3600	4700	3400	35.89	
	All stabilizers down	*40,200	*40,200	*26,900	*26,900	*20,400	18,600	16,300	13,100	12,300	9900	9700	7900	9300	7600		
5.0 ft	All stabilizers up				16,200	11,600	10,800	7900	7900	5800	6100	4400	4800	3500	4600	3400	36.09
	All stabilizers down				*28,400	*28,400	*20,900	17,900	15,900	12,700	12,100	9700	9600	7800	9200	7500	
0.0 ft	All stabilizers up	*8000	*8000	15,300	10,700	10,300	7400	7600	5500	5900	4300						
	All stabilizers down	*8000	*8000	*27,000	*27,000	*20,100	17,300	*15,600	12,400	11,900	9600						
-5.0 ft	All stabilizers up				14,900	10,300	10,000	7100	7400	5300							
	All stabilizers down				*22,200	*22,200	*17,500	17,000	*13,500	12,200							

*Limited by hydraulic rather than tipping load.

Lift capacity ratings are based on ISO 10567:2007, they do not exceed 87% of hydraulic lifting capacity or 75% of tipping load. The load point is the center line of the bucket pivot mounting pin on the stick. The oscillating axle must be locked. Lifting capacities are based on the machine standing on a firm uniform supporting surface. For lifting capacity including bucket and/or quick coupler, the respective weight has to be subtracted from above values. The use of a work tool attachment point to handle/lift objects, could affect the machine lift performance.

Always refer to the appropriate Operation and Maintenance Manual for specific product information.

Lift Capacities

All values are in kg, without bucket and without QC, with counterweight (4000 kg/8818 lb), heavy lift on.



Undercarriage		Boom						Stick						Metric Units						
Standard		6400 mm (21'0")						4200 mm (13'9")												
Undercarriage configuration	3.0 m			4.5 m			6.0 m		7.5 m			9.0 m			10.5 m			m		
	Load point height	Load over front	Load over rear	Load over front	Load over rear	Load over side	Load over front	Load over rear	Load over side	Load over front	Load over rear	Load over side	Load over front	Load over rear	Load over side	Load at maximum reach (sticknose/bucket pin)				
9.0 m	Rear dozer up						5500	4350	3650								3750	2950	2450	7.42
	Rear dozer down							*8100	4150									*5300	2800	
	Dozer and stab down							*8100	6150									*5300	4200	
7.5 m	Rear dozer up						5500	4400	3650	3750	2950	2450					2850	2200	1800	8.64
	Rear dozer down							*8300	4150									4750	2100	
	Dozer and stab down							*8300	6150									*4950	3250	
6.0 m	Rear dozer up				8750	7000	5750	5400	4250	3550	3700	2900	2400	2650	2050	1650	2400	1850	1500	9.46
	Rear dozer down					*10 650	6600		*8550	4050								4050	1750	
	Dozer and stab down					*10 650	9900		*8550	6050								4600	2750	
4.5 m	Rear dozer up	*14 500	13 450	10 500	8300	6550	5350	5150	4050	3350	3600	2800	2300	2600	2000	1600	2150	1600	1300	10.00
	Rear dozer down		*14 500	12 350		*11 600	6150		8900	3850								3650	1550	
	Dozer and stab down		*14 500	*14 500		*11 600	9450		*8900	5800								4150	2450	
3.0 m	Rear dozer up				7650	5900	4800	4850	3750	3100	3450	2650	2150	2550	1900	1550	2000	1500	1200	10.28
	Rear dozer down					*12 500	5550		8550	3550								4300	1800	
	Dozer and stab down					*12 500	8750		*9250	5500								4900	2900	
1.5 m	Rear dozer up				7050	5350	4250	4600	3500	2800	3250	2500	2000	2450	1850	1500	1950	1450	1150	10.34
	Rear dozer down					*12 600	5000		8200	3300								3400	1350	
	Dozer and stab down					*12 600	8150		*9200	5200								3850	2250	
0.0 m	Rear dozer up				6700	5000	3950	4350	3300	2650	3150	2350	1900	2400	1800	1400				
	Rear dozer down					*9450	4700		7950	3100										
	Dozer and stab down					*9450	7750		*8450	5000										

Undercarriage
Special Application

Boom
6400 mm (21'0")

Stick
4200 mm (13'9")

Undercarriage configuration	3.0 m		4.5 m		6.0 m		7.5 m		9.0 m		10.5 m		m			
	Load point height	Load over rear	Load over front	Load over rear	Load over front	Load over rear	Load over front	Load over rear	Load over front	Load over rear	Load at maximum reach (sticknose/bucket pin)					
9.0 m	All stabilizers up					5450	4050						3750	2750	7.42	
	All stabilizers down					*8100	*8100							*5300	*5300	
7.5 m	All stabilizers up						5500	4100	3750	2750				2900	2100	8.64
	All stabilizers down						*8300	*8300	*7050	6050				*4950	4700	
6.0 m	All stabilizers up					8650	6350	5350	3950	3700	2700	2700	1900	2450	1700	9.46
	All stabilizers down					*10 650	*10 650	*8550	*8550	*7100	6000	5500	4400	*4800	4050	
4.5 m	All stabilizers up	*14 500	11 550	8200	5950	5150	3750	3600	2600	2650	1850			2200	1500	10.00
	All stabilizers down	*14 500	*14 500	*11 600	*11 600	*8900	8550	*7250	5900	5450	4350			4550	3650	
3.0 m	All stabilizers up				7600	5350	4850	3500	3450	2450	2550	1800		2050	1400	10.28
	All stabilizers down				*12 500	*12 500	*9250	8200	7200	5700	5350	4250		4300	3450	
1.5 m	All stabilizers up				7000	4850	4550	3250	3300	2300	2500	1750		2000	1350	10.34
	All stabilizers down				*12 600	*12 600	*9200	7900	7050	5550	5250	4200		*4000	3400	
0.0 m	All stabilizers up				6650	4500	4350	3050	3150	2200	2400	1650				
	All stabilizers down				*9450	*9450	*8450	7650	*6500	5400	*4850	4100				

*Limited by hydraulic rather than tipping load.

Lift capacity ratings are based on ISO 10567:2007, they do not exceed 87% of hydraulic lifting capacity or 75% of tipping load. The load point is the center line of the bucket pivot mounting pin on the stick. The oscillating axle must be locked. Lifting capacities are based on the machine standing on a firm uniform supporting surface. For lifting capacity including bucket and/or quick coupler, the respective weight has to be subtracted from above values. The use of a work tool attachment point to handle/lift objects, could affect the machine lift performance.

Always refer to the appropriate Operation and Maintenance Manual for specific product information.

Lift Capacities

All values are in lb, without bucket and without QC, with counterweight (4000 kg/8818 lb), heavy lift on.



Undercarriage		Boom 6400 mm (21'0")						Stick 4200 mm (13'9")						English Units				
Standard		10.0 ft		15.0 ft		20.0 ft		25.0 ft		30.0 ft		35.0 ft		ft				
Undercarriage configuration	Icon	Icon		Icon		Icon		Icon		Icon		Icon		ft				
		30.0 ft	Rear dozer up														8500	6700
Rear dozer down																		
Dozer and stab down																		
25.0 ft	Rear dozer up														6400	5000	4100	28.08
Rear dozer down																		
Dozer and stab down																		
20.0 ft	Rear dozer up														5400	4100	3300	30.91
Rear dozer down																		
Dozer and stab down																		
15.0 ft	Rear dozer up	*31,100	29,000	22,700	17,900	14,100	11,600	11,100	8700	7200	7700	6000	4900	5600	4300	3500	4800	32.74
Rear dozer down																		
Dozer and stab down																		
10.0 ft	Rear dozer up																	33.73
Rear dozer down																		
Dozer and stab down																		
5.0 ft	Rear dozer up																	33.92
Rear dozer down																		
Dozer and stab down																		
0.0 ft	Rear dozer up																	
Rear dozer down																		
Dozer and stab down																		

Undercarriage
Special Application

Boom
6400 mm (21'0")

Stick
4200 mm (13'9")

Undercarriage configuration	10.0 ft		15.0 ft		20.0 ft		25.0 ft		30.0 ft		35.0 ft		ft		
	Icon	Icon	Icon	Icon	Icon	Icon	Icon	Icon	Icon	Icon	Icon				
30.0 ft	All stabilizers up												8600	6300	23.85
All stabilizers down															
25.0 ft	All stabilizers up														28.08
All stabilizers down															
20.0 ft	All stabilizers up														30.91
All stabilizers down															
15.0 ft	All stabilizers up	*31,100	24,900	17,700	12,800	11,100	8100	7700	5600	5700	4000				32.74
All stabilizers down															
10.0 ft	All stabilizers up														33.73
All stabilizers down															
5.0 ft	All stabilizers up														33.92
All stabilizers down															
0.0 ft	All stabilizers up														
All stabilizers down															

*Limited by hydraulic rather than tipping load.

Lift capacity ratings are based on ISO 10567:2007, they do not exceed 87% of hydraulic lifting capacity or 75% of tipping load. The load point is the center line of the bucket pivot mounting pin on the stick. The oscillating axle must be locked. Lifting capacities are based on the machine standing on a firm uniform supporting surface. For lifting capacity including bucket and/or quick coupler, the respective weight has to be subtracted from above values. The use of a work tool attachment point to handle/lift objects, could affect the machine lift performance.

Always refer to the appropriate Operation and Maintenance Manual for specific product information.

Lift Capacities

All values are in kg, without bucket and without QC, with counterweight (5400 kg/11,905 lb), heavy lift on.

Undercarriage Standard **Boom** 6800 mm (22'4") **Stick** 5900 mm (19'4") **Metric Units**

Undercarriage configuration	3.0 m		4.5 m		6.0 m		7.5 m		9.0 m		10.5 m		12.0 m		Load at maximum reach (sticks+se/bucket pin)	
	Load over front	Load over rear	Load over front	Load over rear	Load over front	Load over rear	Load over front	Load over rear	Load over front	Load over rear	Load over front	Load over rear	Load over front	Load over rear	Load over front	Load over rear
Rear dozer up																4500
Rear dozer down					5900	5000										5300
Dozer and stab down					*7450	*7450										*5700
Rear dozer up							5050	4150	3800							3700
Rear dozer down																*4950
Dozer and stab down																*4950
Rear dozer up							5100	4250	3850	3750	3100	2650				3000
Rear dozer down																2400
Dozer and stab down																*4600
Rear dozer up							5100	4200	3800	3750	3100	2650	2300	1950		2550
Rear dozer down																4050
Dozer and stab down																*4600
Rear dozer up							5000	4100	3650	3700	3000	2600	2300	1950		2300
Rear dozer down																3650
Dozer and stab down																4050
Rear dozer up							6850	5950	4800	3950	3550	3800	2900	2500	2800	2250
Rear dozer down																1700
Dozer and stab down																1400
Rear dozer up							10150	8200	6850	5250	4400	4600	3700	3100	2150	3400
Rear dozer down																3400
Dozer and stab down																1600
Rear dozer up							13400	7750	4400	4600	3700	3100	2700	2100	1400	3800
Rear dozer down																2050
Dozer and stab down																1600
Rear dozer up							9200	7350	6000	4800	4350	3900	2800	2650	2100	3300
Rear dozer down																1500
Dozer and stab down																1300
Rear dozer up							*4050	*4050	5850	5350	5680	4450	3650	4100	3250	3000
Rear dozer down																1500
Dozer and stab down																1300
Rear dozer up							8100	6250	5000	5350	4200	3450	3850	3100	2500	2000
Rear dozer down																1500
Dozer and stab down																1248
Rear dozer up							*10450	*10450	9250	8100	6250	5000	5350	4200	3450	3000
Rear dozer down																2250
Dozer and stab down																2250

* Limited by hydraulic rather than tipping load.
Lift capacity ratings are based on ISO 10567:2007; they do not exceed 97% of hydraulic lifting capacity or 75% of tipping load. The load point is the center line of the bucket pivot mounting pin on the stick. The oscillating axle must be locked. Lifting capacities are based on the machine standing on a firm uniform supporting surface. For lifting capacity including bucket and/or quick coupler, the respective weight has to be subtracted from above values. The use of a work tool attachment point to handle/lift objects, could affect the machine lift performance.
Always refer to the appropriate Operation and Maintenance Manual for specific product information.

Lift Capacities

All values are in lb, without bucket and without QC, with counterweight (5400 kg/11,905 lb), heavy lift on.

Undercarriage configuration	Load over front				Load over rear				Load over side				Load at maximum reach (sticks w/ bucket pin)				English Units
	100.0 ft	150.0 ft	20.0 ft	25.0 ft	30.0 ft	35.0 ft	40.0 ft	40.0 ft	40.0 ft	40.0 ft	40.0 ft	40.0 ft	40.0 ft	40.0 ft	ft		
Rear dozer up			15,000	10,800	11,000	8,900	7,600							12,500	10,300	8,800	
Rear dozer down				10,800	11,000	8,700	7,800								12,900	9,800	22.31
Dozer and stab down				*15,600	*15,600	*15,600									*12,900	*12,900	
Rear dozer up					10,800	8,900	7,600								8,400	6,900	5,900
Rear dozer down						*15,400	8,500								*11,100	6,800	28.67
Dozer and stab down						*15,400	11,900								*11,100	9,400	
Rear dozer up					11,000	9,100	7,800	8,000							6,700	5,400	4,600
Rear dozer down					11,000	8,700	7,800	8,000							*10,200	5,200	33.07
Dozer and stab down					*16,400	*16,400	12,100	13,800	8,900						*10,200	7,400	
Rear dozer up					10,900	9,100	7,800	8,100							5,700	4,600	3,900
Rear dozer down					10,900	8,700	7,800	8,000							9,000	4,400	3,622
Dozer and stab down					*16,400	*16,400	12,100	13,800	8,900						*9,700	6,400	
Rear dozer up					10,700	8,900	7,600	8,000							5,100	4,100	3,400
Rear dozer down					10,700	8,500	7,600	8,000							5,100	4,100	3,400
Dozer and stab down					*16,800	*16,800	11,900	13,700	8,800						8,100	3,900	3,848
Rear dozer up					14,800	12,200	10,300	10,400	9,500	7,200	7,700	6,300	6,000		4,700	3,700	3,100
Rear dozer down					14,800	11,800	11,600	11,600	11,600	8,100	12,100	6,000	6,000		7,500	3,600	29.96
Dozer and stab down					*20,700	16,400	16,400	11,500	13,400	8,600	10,500	6,700	6,700		8,400	5,300	
Rear dozer up					21,900	17,700	14,800	13,900	9,900	8,800	7,400	6,000	5,100	5,900	4,800	3,800	2,900
Rear dozer down					23,000	16,700	16,700	22,300	10,700	15,900	7,600	11,800	5,700	9,300	4,400	3,500	2,900
Dozer and stab down					*29,000	24,500	22,500	15,900	17,500	11,000	13,100	8,200	10,300	8,500	7,200	3,400	4,076
Rear dozer up					19,800	15,800	13,000	12,900	10,400	8,700	9,300	7,100	5,700	4,800	4,500	3,700	3,000
Rear dozer down					19,800	14,800	14,800	21,900	9,800	15,200	7,100	11,500	5,400	9,100	3,600	3,400	2,800
Dozer and stab down					*31,800	22,500	23,500	14,500	16,900	10,400	12,800	8,000	10,100	6,300	7,100	3,300	40.94
Rear dozer up					*9,300	*9,300	14,300	11,600	12,100	8,600	7,800	6,800	5,400	4,500	4,800	3,600	3,000
Rear dozer down					*9,300	*9,300	13,400	20,900	9,100	14,700	6,700	11,200	5,100	8,800	4,100	3,400	2,800
Dozer and stab down					*9,300	*9,300	20,800	23,200	13,600	16,300	10,000	12,400	7,700	9,900	6,200	5,200	
Rear dozer up					17,400	13,500	10,600	11,600	9,100	7,400	8,500	6,700	5,500	6,600	4,200	3,500	
Rear dozer down					*24,000	12,600	20,300	8,900	14,300	6,300	10,900	4,900	8,800	4,000	8,800	4,000	
Dozer and stab down					*24,000	19,200	*21,700	13,100	15,900	9,600	12,200	7,500	9,800	6,100	8,800	6,100	

* Limited by hydraulic rather than tipping load.

Lift capacity ratings are based on ISO 10567:2007; they do not exceed 97% of hydraulic lifting capacity or 75% of tipping load. The load point is the center line of the bucket pivot mounting pin on the stick. The oscillating axle must be locked. Lifting capacities are based on the machine standing on a firm uniform supporting surface. For lifting capacity including bucket and/or quick coupler, the respective weight has to be subtracted from above values. The use of a work tool attachment point to handle/lift objects, could affect the machine lift performance.

Always refer to the appropriate Operation and Maintenance Manual for specific product information.

Lift Capacities

All values are in kg, without bucket and without QC, with counterweight (5400 kg/11,905 lb), heavy lift on.

 Load point height

 Load over front

 Load over rear

 Load over side

 Load at maximum reach (sticknose/bucket pin)

Undercarriage

Boom















Stick

Metric Units

Standard

6800 mm (22'4")

4900 mm (16'1")

Stick m	Undercarriage configuration	4.5 m			6.0 m			7.5 m			9.0 m			10.5 m			m			
																				
10.5 m	Rear dozer up				7000	5800	4950	4800	3950	3350							4800	3950	3350	7.50
	Rear dozer down					*9200	5500		*6350	3750								*6350	3750	
	Dozer and stab down					*9200	7750		*6350	5300								*6350	5300	
9.0 m	Rear dozer up				7100	5900	5050	4950	4050	3500							3600	2950	2500	8.98
	Rear dozer down					*9300	5600		7750	3900								5650	2800	
	Dozer and stab down					*9300	7850		*8100	5450								*5750	4000	
7.5 m	Rear dozer up				7050	5850	5000	4950	4050	3500	3650	3000	2550				3050	2450	2050	10.02
	Rear dozer down					*9350	5550		7750	3900								4750	2350	
	Dozer and stab down					*9350	7800		*8050	5450								5250	3350	
6.0 m	Rear dozer up				6900	5700	4850	4850	4000	3400	3600	2950	2500	2800	2250	1900	2700	2150	1800	10.74
	Rear dozer down					*9700	5400		7650	3800								4200	2050	
	Dozer and stab down					*9700	7650		*8200	5350								4700	3000	
4.5 m	Rear dozer up	10 400	8500	7100	6600	5400	4550	4700	3800	3250	3550	2850	2450	2750	2200	1850	2450	1950	1650	11.22
	Rear dozer down		*13 150	8000		*10 300	5150		7450	3650					4350	2100	3900	1900		
	Dozer and stab down		*13 150	11 700		*10 300	7350		8250	5200					4850	3100	4350	2750		
3.0 m	Rear dozer up	9600	7750	6400	6200	5050	4250	4500	3650	3050	3400	2750	2300	2700	2150	1800	2350	1850	1550	11.47
	Rear dozer down		*14 550	7250		10 450	4800		7250	3450					4300	2050	3750	1800		
	Dozer and stab down		*14 550	10 850		*10 850	6950		8000	5000					4750	3000	4150	2650		
1.5 m	Rear dozer up	8850	7000	5700	5850	4700	3900	4300	3450	2850	3300	2650	2200	2650	2100	1750	2300	1800	1500	11.52
	Rear dozer down		*15 050	6550		10 000	4450		7000	3250					4200	2000	3700	1750		
	Dozer and stab down		*15 050	10 050		*11 050	6550		7750	4800					4700	2950	4100	2600		
0.0 m	Rear dozer up	8350	6550	5250	5550	4400	3650	4100	3250	2700	3200	2550	2100	2600	2050	1700				
	Rear dozer down		*10 200	6100		9700	4150		6800	3100					4150	1950				
	Dozer and stab down		*10 200	9550		*10 550	6300		7600	4600					4650	2900				
-1.5 m	Rear dozer up				5400	4250	3500	4000	3150	2600										
	Rear dozer down					*9150	4000		6700	3000										
	Dozer and stab down					*9150	6150		*7250	4500										

* Limited by hydraulic rather than tipping load.

Lift capacity ratings are based on ISO 10567:2007, they do not exceed 87% of hydraulic lifting capacity or 75% of tipping load. The load point is the center line of the bucket pivot mounting pin on the stick. The oscillating axle must be locked. Lifting capacities are based on the machine standing on a firm uniform supporting surface. For lifting capacity including bucket and/or quick coupler, the respective weight has to be subtracted from above values. The use of a work tool attachment point to handle/lift objects, could affect the machine lift performance.

Always refer to the appropriate Operation and Maintenance Manual for specific product information.

Lift Capacities

All values are in lb, without bucket and without QC, with counterweight (5400 kg/11,905 lb), heavy lift on.



Undercarriage **Boom** **Stick** **English Units**
Standard 6800 mm (22'4") 4900 mm (16'1")

Undercarriage configuration	15.0 ft			20.0 ft			25.0 ft			30.0 ft			35.0 ft			ft				
	Load point height	Load over front	Load over rear	Load over front	Load over rear	Load over side	Load over front	Load over rear	Load over side	Load over front	Load over rear	Load over side	Load over front	Load over rear	Load over side					
35.0 ft	Rear dozer up				15,000	12,400	10,600										11,100	9100	7800	
	Rear dozer down					*19,500	11,800											*14,200	8700	23.95
	Dozer and stab down					*19,500	16,600											*14,200	12,300	
30.0 ft	Rear dozer up				15,200	12,600	10,800	10,600	8700	7500							8200	6700	5700	
	Rear dozer down					*20,300	12,000											*12,700	6400	29.07
	Dozer and stab down					*20,300	16,800											*12,700	9000	
25.0 ft	Rear dozer up				15,200	12,600	10,700	10,600	8700	7500	7800	6400	5500				6800	5500	4600	
	Rear dozer down					*20,400	12,000					12,200	6100					10,600	5200	32.64
	Dozer and stab down					*20,400	16,800					13,500	8700					11,700	7500	
20.0 ft	Rear dozer up				14,800	12,200	10,400	10,400	8600	7300	7800	6300	5400	6000	4800	4000	5900	4800	4000	35.10
	Rear dozer down					*21,100	11,600					12,200	6100					9300	4600	
	Dozer and stab down					*21,100	16,400					13,400	8600					10,400	6700	
15.0 ft	Rear dozer up	22,400	18,300	15,300	14,200	11,600	9900	10,100	8200	7000	7600	6200	5200	5900	4800	4000	5500	4400	3700	
	Rear dozer down		*28,500	17,300		*22,300	11,100					12,000	5900					9300	4500	36.75
	Dozer and stab down		*28,500	25,200		*22,300	15,800					13,200	8500					10,400	6600	
10.0 ft	Rear dozer up	20,700	16,700	13,800	13,400	10,900	9100	9700	7800	6600	7400	5900	5000	5800	4600	3900	5200	4100	3400	
	Rear dozer down		*31,400	15,700		22,500	10,300					11,700	5700					9200	4400	37.63
	Dozer and stab down		*31,400	23,400		*23,500	15,000					13,000	8200					10,300	6500	
5.0 ft	Rear dozer up	19,100	15,100	12,300	12,600	10,100	8400	9200	7400	6200	7100	5700	4800	5700	4500	3800	5100	4000	3300	
	Rear dozer down		*32,600	14,200		21,500	9600					11,400	5400					9100	4300	37.83
	Dozer and stab down		*32,600	21,700		23,800	14,200					12,700	8000					10,100	6400	
0.0 ft	Rear dozer up	18,000	14,100	11,400	12,000	9500	7900	8900	7100	5900	6900	5500	4600	5600	4400	3700				
	Rear dozer down		*23,900	13,200		20,800	9000					11,200	5200					9000	4200	
	Dozer and stab down		*23,900	20,600		*22,900	13,600					12,500	7800					10,000	6300	
-5.0 ft	Rear dozer up				11,700	9200	7500	8700	6800	5700										
	Rear dozer down					*19,800	8700													
	Dozer and stab down					*19,800	13,200													

* Limited by hydraulic rather than tipping load.

Lift capacity ratings are based on ISO 10567:2007, they do not exceed 87% of hydraulic lifting capacity or 75% of tipping load. The load point is the center line of the bucket pivot mounting pin on the stick. The oscillating axle must be locked. Lifting capacities are based on the machine standing on a firm uniform supporting surface. For lifting capacity including bucket and/or quick coupler, the respective weight has to be subtracted from above values. The use of a work tool attachment point to handle/lift objects, could affect the machine lift performance.

Always refer to the appropriate Operation and Maintenance Manual for specific product information.

Lift Capacities

All values are in kg, without bucket and without QC, with counterweight (5400 kg/11,905 lb), heavy lift on.

 Load point height

 Load over front

 Load over rear

 Load over side

 Load at maximum reach (sticknose/bucket pin)

Undercarriage

Boom



















Stick

Metric Units

Standard

6800 mm (22'4")

4800 mm (15'9")

Undercarriage configuration	4.5 m			6.0 m			7.5 m			9.0 m			10.5 m			Load at maximum reach (sticknose/bucket pin)			m	
																				
10.5 m Rear dozer up Rear dozer down Dozer and stab down				6700	5500 *8900	4650 5200											4650	3750 *6200	3150 3550	7.35
9.0 m Rear dozer up Rear dozer down Dozer and stab down				6800	5600 *9050	4750 5300	4600	3750 *7750	3150 3550								3400	2700 5500	2250 2550	8.86
7.5 m Rear dozer up Rear dozer down Dozer and stab down				6750	5550 *9100	4700 5250	4600	3750 *7900	3150 3550	3350	2650	2200					2750	2150 4500	1800 2050	9.91
6.0 m Rear dozer up Rear dozer down Dozer and stab down				6550	5350 *9400	4500 5100	4500	3650 *7900	3050 3450	3300	2600	2200	2450	1900	1550		2400	1850 3950	1500 1750	10.64
4.5 m Rear dozer up Rear dozer down Dozer and stab down	10 050	8100 *12 900	6700 7650	6250	5050 *9950	4200 4800	4350	3500 7150	2900 3300	3200	2500	2100	2450	1900	1550	2150	1650 4000	1350 1800	11.12	
3.0 m Rear dozer up Rear dozer down Dozer and stab down	9200	7300 *14 150	5950 6850	5850	4650 *10 450	3850 4400	4100	3250 6900	2700 3100	3050	2400	1950	2350	1800	1450	2050	1550 3600	1250 1450	11.38	
1.5 m Rear dozer up Rear dozer down Dozer and stab down	8350	6500 *14 550	5200 6050	5450	4300 *10 600	3500 4050	3900	3050 6650	2500 2900	2950	2300	1850	2300	1750	1400	2000	1500 3400	1200 1400	11.43	
0.0 m Rear dozer up Rear dozer down Dozer and stab down	7850	6050 *9650	4800 5600	5150	4000 *10 000	3200 3750	3750	2900 6450	2350 2700	2850	2200	1750	2250	1700	1350		3800 1600			
-1.5 m Rear dozer up Rear dozer down Dozer and stab down				5000	3850 *8550	3050 3600	3600	2800 *6700	2250 4100											

* Limited by hydraulic rather than tipping load.

Lift capacity ratings are based on ISO 10567:2007, they do not exceed 87% of hydraulic lifting capacity or 75% of tipping load. The load point is the center line of the bucket pivot mounting pin on the stick. The oscillating axle must be locked. Lifting capacities are based on the machine standing on a firm uniform supporting surface. For lifting capacity including bucket and/or quick coupler, the respective weight has to be subtracted from above values. The use of a work tool attachment point to handle/lift objects, could affect the machine lift performance.

Always refer to the appropriate Operation and Maintenance Manual for specific product information.

Lift Capacities

All values are in lb, without bucket and without QC, with counterweight (5400 kg/11,905 lb), heavy lift on.



Undercarriage **Boom** **Stick** **English Units**
Standard 6800 mm (22'4") 4800 mm (15'9")

Stick height	Undercarriage configuration	15.0 ft			20.0 ft			25.0 ft			30.0 ft			35.0 ft			ft				
		Load point height	Load over front	Load over rear	Load point height	Load over front	Load over rear	Load point height	Load over front	Load over rear	Load point height	Load over front	Load over rear	Load point height	Load over front	Load over rear					
35.0 ft	Rear dozer up				14,300	11,700	9900										10,700	8700	7300	23.43	
	Rear dozer down					*18,800	11,100											*13,900	8300		
	Dozer and stab down					*18,800	15,900											*13,900	12,000		
30.0 ft	Rear dozer up				14,600	12,000	10,100	9900	8000	6800							7600	6100	5100	28.67	
	Rear dozer down					*19,700	11,400			16,000	7600								*12,400		5800
	Dozer and stab down					*19,700	16,200			*17,000	11,000								*12,400		8500
25.0 ft	Rear dozer up				14,500	11,900	10,100	9900	8000	6800	7100	5700	4700				6200	4800	4000	32.28	
	Rear dozer down					*19,800	11,300			16,000	7600	11,500	5400					10,000	4600		
	Dozer and stab down					*19,800	16,100			*16,900	11,000	12,800	8000					11,200	6900		
20.0 ft	Rear dozer up				14,100	11,500	9700	9700	7800	6600	7100	5600	4700				5300	4100	3400	34.78	
	Rear dozer down					*20,500	10,900			15,700	7500	11,400	5300					8800	3900		
	Dozer and stab down					*20,500	15,700			*17,100	10,800	12,700	7900					9800	6000		
15.0 ft	Rear dozer up	21,600	17,500	14,500	13,400	10,900	9100	9300	7500	6200	6900	5400	4500	5200	4000	3300	4800	3700	3000	36.42	
	Rear dozer down		*27,900	16,500		*21,600	10,300			15,300	7100	11,200	5100					8600	3800		
	Dozer and stab down		*27,900	24,400		*21,600	15,000			17,000	10,400	12,500	7700					9700	5900		
10.0 ft	Rear dozer up	19,800	15,700	12,900	12,600	10,000	8300	8900	7000	5800	6600	5200	4200	5100	3900	3100	4500	3400	2700	37.30	
	Rear dozer down		*30,600	14,800		21,700	9500			14,800	6700	10,900	4900					8500	3700		
	Dozer and stab down		*30,600	22,500		*22,700	14,200			16,400	10,000	12,200	7500					9500	5800		
5.0 ft	Rear dozer up	18,000	14,000	11,300	11,700	9200	7500	8400	6600	5400	6300	4900	4000	4900	3800	3000	4400	3300	2600	37.50	
	Rear dozer down		*31,500	13,100		20,600	8700			14,300	6200	10,700	4600					8300	3500		
	Dozer and stab down		*31,500	20,600		22,900	13,300			15,900	9500	11,900	7200					9400	5600		
0.0 ft	Rear dozer up	16,900	13,000	10,300	11,100	8600	6900	8000	6200	5000	6100	4700	3800	4800	3700	2900					
	Rear dozer down		*22,600	12,100		19,800	8100			13,800	5900	10,400	4400					8200	3400		
	Dozer and stab down		*22,600	19,500		*21,700	12,600			15,500	9100	11,700	7000					9300	5500		
-5.0 ft	Rear dozer up				10,700	8300	6600	7800	6000	4800											
	Rear dozer down					*18,500	7700			13,600	5600										
	Dozer and stab down					*18,500	12,300			*14,400	8900										

*Limited by hydraulic rather than tipping load.

Lift capacity ratings are based on ISO 10567:2007, they do not exceed 87% of hydraulic lifting capacity or 75% of tipping load. The load point is the center line of the bucket pivot mounting pin on the stick. The oscillating axle must be locked. Lifting capacities are based on the machine standing on a firm uniform supporting surface. For lifting capacity including bucket and/or quick coupler, the respective weight has to be subtracted from above values. The use of a work tool attachment point to handle/lift objects, could affect the machine lift performance.

Always refer to the appropriate Operation and Maintenance Manual for specific product information.

Lift Capacities

All values are in kg, without bucket and without QC, with counterweight (5400 kg/11,905 lb), heavy lift on.

Metric Units

		Load point height	Load over front	Load over rear	Load over side		Load at maximum reach (sticknose/bucket pin)											
Undercarriage Special Application	Undercarriage configuration	3.0 m		4.5 m		6.0 m		7.5 m		9.0 m		10.5 m		12.0 m		m		
12.0 m	All stabilizers up					7000	5400									5300	4050	
	All stabilizers down					*7450	*7450									*5700	*5700	
10.5 m	All stabilizers up							5000	3900								3700	2850
	All stabilizers down							*7250	*7250								*4950	*4950
9.0 m	All stabilizers up							5100	3950	3750	2900						3000	2250
	All stabilizers down							*7500	*7500	*6750	5700						*4600	4600
7.5 m	All stabilizers up							5050	3950	3750	2900	2850	2150				2550	1950
	All stabilizers down							*7550	*7550	*6700	5700	5350	4400				*4400	4000
6.0 m	All stabilizers up							4950	3850	3700	2850	2850	2150				2300	1700
	All stabilizers down							*7750	7550	*6800	5650	5350	4400				*4300	3600
4.5 m	All stabilizers up					6800	5200	4800	3650	3600	2750	2800	2100	2200	1650	2150	1600	
	All stabilizers down					*9550	*9550	*8050	7350	6750	5500	5250	4300	4250	3500	4150	3400	
3.0 m	All stabilizers up			9950	7400	6400	4850	4550	3450	3450	2600	2700	2000	2200	1600	2050	1500	
	All stabilizers down			*13 400	*13 400	*10 300	*10 200	*8400	7100	6600	5350	5200	4250	4200	3450	4050	3250	
1.5 m	All stabilizers up			9050	6600	5950	4400	4300	3200	3300	2450	2650	1950	2150	1550	2000	1450	
	All stabilizers down			*14 700	*14 700	*10 850	9700	8500	6850	6400	5200	5100	4150	4150	3400	3950	3200	
0.0 m	All stabilizers up	*4050	*4050	8350	5950	5550	4050	4100	3000	3200	2350	2550	1850	2100	1500			
	All stabilizers down	*4050	*4050	*14 700	*14 700	*10 800	9250	8250	6600	6250	5050	5000	4050	*4050	3350			
-1.5 m	All stabilizers up			7950	5600	5300	3850	3950	2850	3100	2250	2500	1800					
	All stabilizers down			*10 450	*10 450	*10 000	8950	*7850	6450	6150	4950	*2480	4000					

Undercarriage
Special Application

Boom
6800 mm (22'4")

Stick
4900 mm (16'1")

Undercarriage configuration	4.5 m		6.0 m		7.5 m		9.0 m		10.5 m		m	
All stabilizers up			6950	5350	4800	3700					4800	3700
All stabilizers down			*9200	*9200	*6350	*6350					*6350	*6350
All stabilizers up			7000	5450	4900	3800					3600	2750
All stabilizers down			*9300	*9300	*8100	7500					*5750	5550
All stabilizers up			7000	5400	4900	3800	3650	2800			3050	2300
All stabilizers down			*9350	*9350	*8050	7500	6800	5550			*5450	4650
All stabilizers up			6800	5250	4800	3700	3600	2750	2800	2100	2700	2000
All stabilizers down			*9700	*9700	*8200	7400	6750	5550	5250	4300	5050	4150
All stabilizers up	10 250	7650	6550	5000	4650	3550	3550	2700	2750	2100	2500	1850
All stabilizers down	*13 150	*13 150	*10 300	*10 300	*8450	7200	6650	5450	5200	4300	4700	3850
All stabilizers up	9450	6950	6150	4650	4450	3350	3400	2600	2700	2050	2350	1750
All stabilizers down	*14 550	*14 550	*10 850	9950	8650	7000	6550	5300	5150	4200	4500	3700
All stabilizers up	8700	6300	5800	4300	4250	3200	3300	2450	2650	1950	2300	1700
All stabilizers down	*15 050	*15 050	*11 050	9500	8450	6800	6400	5200	5100	4150	*4450	3650
All stabilizers up	8250	5850	5550	4050	4100	3050	3200	2350	2600	1900		
All stabilizers down	*10 200	*10 200	*10 550	9200	*8250	6600	6300	5100	*5000	4100		
All stabilizers up			5400	3900	4000	2950						
All stabilizers down			*9150	9000	*7250	6500						

Undercarriage
Special Application

Boom
6800 mm (22'4")

Stick
4800 mm (15'9")

Undercarriage configuration	4.5 m		6.0 m		7.5 m		9.0 m		10.5 m		m	
All stabilizers up			6600	5050							4600	3500
All stabilizers down			*8900	*8900							*6200	*6200
All stabilizers up			6750	5150	4600	3500					3350	2500
All stabilizers down			*9050	*9050	*7750	7200					*5650	5300
All stabilizers up			6700	5100	4600	3450	3300	2450			2750	2000
All stabilizers down			*9100	*9100	*7750	7200	6450	5250			*5250	4400
All stabilizers up			6500	4900	4500	3400	3300	2450	2450	1750	2400	1700
All stabilizers down			*9400	*9400	*7900	7050	6400	5200	4900	4000	4800	3900
All stabilizers up	9850	7300	6200	4650	4300	3200	3200	2350	2450	1750	2150	1550
All stabilizers down	*12 900	*12 900	*9950	*9950	*8100	6900	6300	5100	4900	3950	4450	3550
All stabilizers up	9050	6550	5800	4250	4100	3000	3050	2250	2350	1700	2050	1450
All stabilizers down	*14 150	*14 150	*10 450	9550	*8300	6650	6200	4950	4800	3900	4250	3400
All stabilizers up	8250	5800	5400	3900	3900	2800	2900	2100	2300	1600	2000	1400
All stabilizers down	*14 550	*14 550	*10 600	9100	8050	6400	6050	4850	4750	3800	*4100	3350
All stabilizers up	7750	5350	5100	3600	3700	2650	2850	2000	2250	1550		
All stabilizers down	*9650	*9650	*10 000	8750	*7750	6200	5900	4750	*4500	3750		
All stabilizers up			4950	3450	3600	2550						
All stabilizers down			*8550	*8550	*6700	6100						

*Limited by hydraulic rather than tipping load.

Lift capacity ratings are based on ISO 10567:2007, they do not exceed 87% of hydraulic lifting capacity or 75% of tipping load. The load point is the center line of the bucket pivot mounting pin on the stick. The oscillating axle must be locked. Lifting capacities are based on the machine standing on a firm uniform supporting surface. For lifting capacity including bucket and/or quick coupler, the respective weight has to be subtracted from above values. The use of a work tool attachment point to handle/lift objects, could affect the machine lift performance.

Always refer to the appropriate Operation and Maintenance Manual for specific product information.

Lift Capacities

All values are in lb, without bucket and without QC, with counterweight (5400 kg/11,905 lb), heavy lift on.

English Units

		Load point height	Load over front	Load over rear	Load over side	Load at maximum reach (sticknose/bucket pin)										ft	
Undercarriage Special Application	Undercarriage configuration	10.0 ft		15.0 ft		20.0 ft		25.0 ft		30.0 ft		35.0 ft		40.0 ft		ft	
40.0 ft	All stabilizers up					14,900	11,500									12,400	9500
	All stabilizers down					*15,600	*15,600									*12,900	*12,900
35.0 ft	All stabilizers up							10,700	8300							8400	6500
	All stabilizers down							*15,400	*15,400							*11,100	*11,100
30.0 ft	All stabilizers up							10,900	8500	8000	6200					6700	5100
	All stabilizers down							*16,400	*16,400	*14,400	12,200					*10,200	*10,200
25.0 ft	All stabilizers up							10,900	8500	8100	6200	6100	4600			5700	4300
	All stabilizers down							*16,400	*16,400	*14,600	12,200	11,500	9400			*9700	8900
20.0 ft	All stabilizers up							10,700	8300	7900	6100	6100	4600			5100	3800
	All stabilizers down							*16,800	16,300	14,700	12,100	11,400	9400			*9500	8000
15.0 ft	All stabilizers up					14,600	11,200	10,300	7900	7700	5900	6000	4500			4700	3500
	All stabilizers down					*20,700	*20,700	*17,500	15,900	14,500	11,900	11,300	9300			9100	7500
10.0 ft	All stabilizers up			21,500	16,000	13,800	10,400	9800	7500	7400	5600	5800	4300	4700	3400	4500	3300
	All stabilizers down			*29,000	*29,000	*22,300	21,900	*18,200	15,300	14,200	11,600	11,100	9100	9100	7400	8800	7200
5.0 ft	All stabilizers up			19,500	14,200	12,800	9500	9300	7000	7100	5300	5700	4200	4600	3300	4400	3200
	All stabilizers down			*31,800	*31,800	*23,500	20,800	18,300	14,700	13,800	11,200	10,900	8900	9000	7300	8700	7100
0.0 ft	All stabilizers up	*9300	*9300	18,000	12,800	12,000	8800	8800	6500	6900	5000	5500	4000				
	All stabilizers down	*9300	*9300	*31,900	*31,900	*23,400	19,900	17,800	14,200	13,500	10,900	10,800	8800				
-5.0 ft	All stabilizers up			17,100	12,100	11,500	8300	8500	6200	6600	4800	5400	3900				
	All stabilizers down			*24,000	*24,000	*21,700	19,300	*16,900	13,800	13,300	10,700	*10,200	8600				

Undercarriage
Special Application

Boom
6800 mm (22'4")

Stick
4900 mm (16'1")

Undercarriage configuration	15.0 ft		20.0 ft		25.0 ft		30.0 ft		35.0 ft		ft		
35.0 ft	All stabilizers up			14,800	11,400						11,000	8500	
	All stabilizers down			*19,500	*19,500						*14,200	*14,200	
30.0 ft	All stabilizers up			15,100	11,700	10,500	8200				8100	6200	
	All stabilizers down			*20,300	*20,300	*17,700	16,100				*12,700	12,500	
25.0 ft	All stabilizers up			15,000	11,600	10,600	8200	7800	6000		6800	5100	
	All stabilizers down			*20,400	*20,400	*17,600	16,100	14,600	12,000		*12,000	10,400	
20.0 ft	All stabilizers up			14,700	11,300	10,400	8000	7800	5900	6000	4500	6000	4500
	All stabilizers down			*21,100	*21,100	*17,900	15,900	14,500	11,900	11,300	9300	11,200	9200
15.0 ft	All stabilizers up	22,100	16,600	14,100	10,700	10,100	7700	7600	5800	5900	4500	5500	4100
	All stabilizers down	*28,500	*28,500	*22,300	22,300	*18,400	15,500	14,300	11,700	11,200	9200	10,400	8500
10.0 ft	All stabilizers up	20,400	15,100	13,300	10,000	9600	7300	7400	5500	5800	4400	5200	3900
	All stabilizers down	*31,400	*31,400	*23,500	21,400	18,700	15,100	14,000	11,500	11,100	9100	10,000	8200
5.0 ft	All stabilizers up	18,800	13,600	12,500	9300	9200	6900	7100	5300	5700	4200	5100	3800
	All stabilizers down	*32,600	*32,600	*24,000	20,500	18,200	14,600	13,800	11,200	11,000	9000	9800	8000
0.0 ft	All stabilizers up	17,800	12,600	11,900	8700	8900	6500	6900	5100	5600	4100		
	All stabilizers down	*23,900	*23,900	*22,900	19,800	17,700	14,200	13,500	11,000	*10,600	8900		
-5.0 ft	All stabilizers up			11,600	8400	8600	6300						
	All stabilizers down			*19,800	19,400	*15,600	14,000						

Undercarriage
Special Application

Boom
6800 mm (22'4")

Stick
4800 mm (15'9")

Undercarriage configuration	15.0 ft		20.0 ft		25.0 ft		30.0 ft		35.0 ft		ft		
35.0 ft	All stabilizers up			14,200	10,800						10,700	8000	
	All stabilizers down			*18,800	*18,800						*13,900	*13,900	
30.0 ft	All stabilizers up			14,400	11,000	9800	7400				7600	5700	
	All stabilizers down			*19,700	*19,700	*17,000	15,400				*12,400	12,100	
25.0 ft	All stabilizers up			14,400	10,900	9900	7500	7100	5300		6200	4500	
	All stabilizers down			*19,800	*19,800	*16,900	15,400	13,900	11,300		*11,600	9800	
20.0 ft	All stabilizers up			14,000	10,600	9700	7300	7000	5200		5300	3800	
	All stabilizers down			*20,500	*20,500	*17,100	15,200	13,800	11,200		10,700	8600	
15.0 ft	All stabilizers up	21,300	15,800	13,300	10,000	9300	6900	6900	5000	5200	3700	4800	3400
	All stabilizers down	*27,900	*27,900	*21,600	21,500	*17,600	14,800	13,600	11,000	10,500	8500	9800	7900
10.0 ft	All stabilizers up	19,500	14,100	12,500	9200	8800	6500	6600	4800	5100	3600	4500	3200
	All stabilizers down	*30,600	*30,600	*22,700	20,500	17,900	14,300	13,300	10,700	10,400	8300	9300	7500
5.0 ft	All stabilizers up	17,700	12,500	11,600	8400	8400	6000	6300	4500	5000	3500	4400	3100
	All stabilizers down	*31,500	*31,500	*23,000	19,600	17,300	13,800	13,000	10,400	10,200	8200	*9000	7400
0.0 ft	All stabilizers up	16,700	11,600	11,000	7800	8000	5700	6100	4300	4800	3400		
	All stabilizers down	*22,600	*22,600	*21,700	18,800	*16,800	13,400	12,700	10,200	*9500	8100		
-5.0 ft	All stabilizers up			10,700	7500	7800	5500						
	All stabilizers down			*18,500	18,400	*14,400	13,100						

*Limited by hydraulic rather than tipping load.

Lift capacity ratings are based on ISO 10567:2007, they do not exceed 87% of hydraulic lifting capacity or 75% of tipping load. The load point is the center line of the bucket pivot mounting pin on the stick. The oscillating axle must be locked. Lifting capacities are based on the machine standing on a firm uniform supporting surface. For lifting capacity including bucket and/or quick coupler, the respective weight has to be subtracted from above values. The use of a work tool attachment point to handle/lift objects, could affect the machine lift performance.

Always refer to the appropriate Operation and Maintenance Manual for specific product information.

● M325D MH ● M325D LMH
(Ireland Sourced)

Material Handlers

Model	M325D MH		M325D LMH	
Horsepower (ISO 9249 Net) (LRC countries)	140 kW	190 hp	140 kW	190 hp
Horsepower (ISO 9249 Net) (NACD)	140 kW	190 hp	152 kW	204 hp
No. of Tires	8 (4 Duals)		4 Single	
Tire Size	12.00-20 dual solid rubber		16.00-25 single solid rubber	
Maximum Travel Speed	20 km/h	12.4 mph	18 km/h	11 mph
Hydraulic Cab Riser Maximum Height	2.6 m	8'6"	2.6 m	8'6"

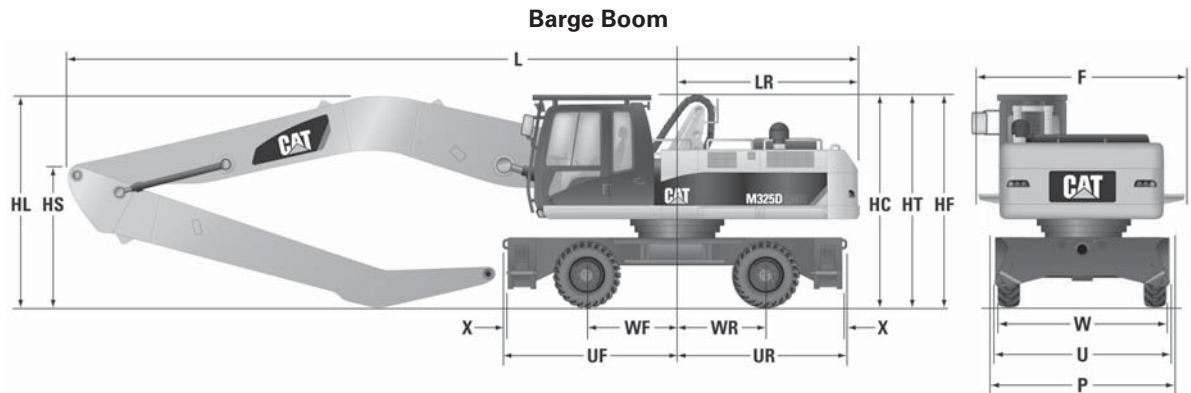

		M325D MH						M325D LMH					
		Boom	Scrap Boom 9.3 m			Barge Boom 9.9 m			Scrap Boom 9.3 m			Barge Boom 9.9 m	
	Stick	7str	5.7 MH	7.1 MH	7str	5.7 MH	7.1 MH	7str	5.7 MH	7.1 MH	7str	5.7 MH	7.1 MH ⁽¹⁾
Shipping Weight (Boom + Stick installed) approximate	[t]	33	32.5	32.5	33.5	33	33	37	36.5	36.5	37.5	37	37
Tail Swing Radius (center SBRG – CTWT)	LR [m]	3.02	3.02	3.02	3.02	3.02	3.02	3.03	3.03	3.03	3.03	3.03	3.03 ⁽¹⁾
Overall Length (linkage – CTWT)	L [m]	12.6	12.7	12.6	13.3	13.3	13.3	12.7	12.7	12.7	13.2	13.2	13.2 ⁽¹⁾
Linkage Height (including lines)	HL [m]	3.5	3.0	3.4	3.3	3.5	3.5	3.4	3.0	3.3	3.4	3.6	3.6 ⁽¹⁾
Linkage Height (without lines)	HS [m]	3.4	2.9	3.3	3.3	3.5	3.5	3.3	3.0	3.2	3.4	3.6	3.6 ⁽¹⁾
Width Upperframe (without Walkway and Platform)	F [m]	2.95						2.95					
Cab Height with FOGS	HF [m]	3.49 ⁽²⁾			3.47 ⁽³⁾			3.73 ⁽⁴⁾			3.78 ⁽⁵⁾		
Cab Height without FOGS	HC [m]	3.36 ⁽²⁾			3.34 ⁽³⁾			3.60 ⁽⁴⁾			3.65 ⁽⁵⁾		
HCR Tower Height	HT [m]	3.47 ⁽²⁾			3.45 ⁽³⁾			3.71 ⁽⁴⁾			3.76 ⁽⁵⁾		
Width Stabilizer Pads	P [m]	3.28						3.24					
Width Undercarriage	U [m]	2.99						2.99					
Width Wheels	W [m]	2.93 ⁽²⁾			2.95 ⁽³⁾			3.00 ⁽⁴⁾			3.18 ⁽⁵⁾		
Wheelbase (Front)	WF [m]	1.50						1.68					
Wheelbase (Rear)	WR [m]	1.50						1.53					
Undercarriage Length (Front)	UF [m]	2.91						3.21					
Undercarriage Length (Rear)	UR [m]	2.91						3.03					
	X [m]	0.13						0.13					

⁽¹⁾ = Transportation ONLY OVER REAR (over front stick will touch undercarriage)

⁽²⁾ = 12.00-20 Dual Tires (Standard)

⁽³⁾ = 11.00-20 Dual Tires

⁽⁴⁾ = 16.0-25 Single Tires (Standard)

⁽⁵⁾ = 23.5-R25 Michelin Tires

Material Handlers

Dimensions

- M325D MH ● M325D LMH
- (Ireland Sourced)

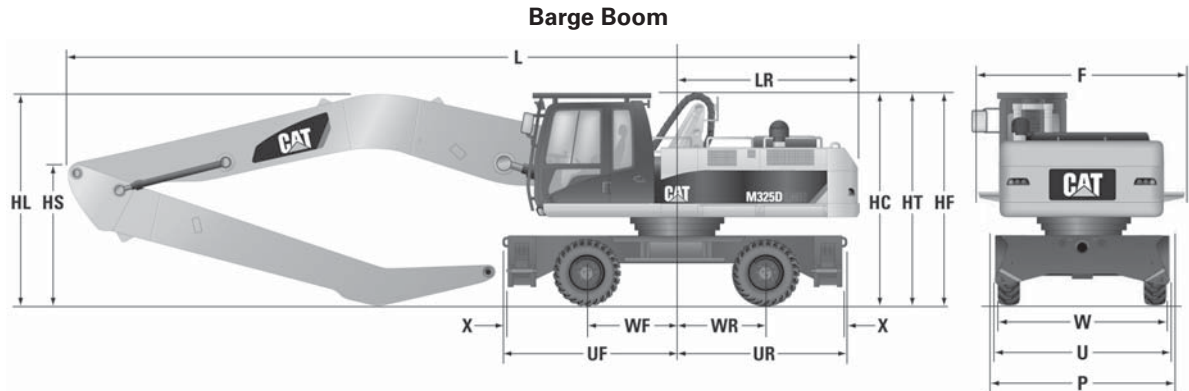

M325D MH

M325D LMH

	Boom	Scrap Boom 30'6"			Barge Boom 32'6"			Scrap Boom 30'6"			Barge Boom 32'6"		
	Stick	23'0" str	18'8" MH	23'4" MH	23'0" str	18'8" MH	23'4" MH	23'0" str	18'8" MH	23'4" MH	23'0" str	18'8" MH	23'4" MH ⁽¹⁾
Shipping Weight (Boom + Stick installed) approximate	[lb]	72,752	71,650	71,650	73,854	72,752	72,752	81,571	80,468	80,468	82,673	81,571	81,571
Tail Swing Radius (center SBRG – CTWT)	LR [ft]	9'11"	9'11"	9'11"	9'11"	9'11"	9'11"	9'11"	9'11"	9'11"	9'11"	9'11"	9'11" ⁽¹⁾
Overall Length (linkage – CTWT)	L [ft]	41'4"	41'8"	41'4"	43'8"	43'8"	43'8"	41'8"	41'8"	41'8"	43'4"	43'4"	43'4" ⁽¹⁾
Linkage Height (including lines)	HL [ft]	11'6"	9'10"	11'2"	10'10"	11'6"	11'6"	11'2"	9'10"	10'10"	11'2"	11'10"	11'10" ⁽¹⁾
Linkage Height (without lines)	HS [ft]	11'2"	9'6"	10'10"	10'10"	11'6"	11'6"	10'10"	9'10"	10'6"	11'2"	11'10"	11'10" ⁽¹⁾
Width Upperframe (without Walkway and Platform)	F [ft]	9'8"						9'8"					
Cab Height with FOGS	HF [ft]	11'5" ⁽²⁾			11'5" ⁽³⁾			12'3" ⁽⁴⁾			12'5" ⁽⁵⁾		
Cab Height without FOGS	HC [ft]	11'0" ⁽²⁾			11'0" ⁽³⁾			11'10" ⁽⁴⁾			12'0" ⁽⁵⁾		
HCR Tower Height	HT [ft]	11'5" ⁽²⁾			11'4" ⁽³⁾			12'2" ⁽⁴⁾			12'4" ⁽⁵⁾		
Width Stabilizer Pads	P [ft]	10'9"						10'8"					
Width Undercarriage	U [ft]	9'10"						9'10"					
Width Wheels	W [ft]	9'7" ⁽²⁾			9'8" ⁽³⁾			9'10" ⁽⁴⁾			10'5" ⁽⁵⁾		
Wheelbase (Front)	WF [ft]	4'11"						5'6"					
Wheelbase (Rear)	WR [ft]	4'11"						5'0"					
Undercarriage Length (Front)	UF [ft]	9'7"						10'6"					
Undercarriage Length (Rear)	UR [ft]	9'7"						9'11"					
	X [ft]	5"						5"					

⁽¹⁾ = Transportation ONLY OVER REAR (over front stick will touch undercarriage)

⁽²⁾ = 12.00-20 Dual Tires (Standard)

⁽³⁾ = 11.00-20 Dual Tires

⁽⁴⁾ = 16.0-25 Single Tires (Standard)

⁽⁵⁾ = 23.5-R25 Michelin Tires

M325D MH Working Range

- Maximum Reach 14.4 m (47'3") or 15.5 m (50'10")

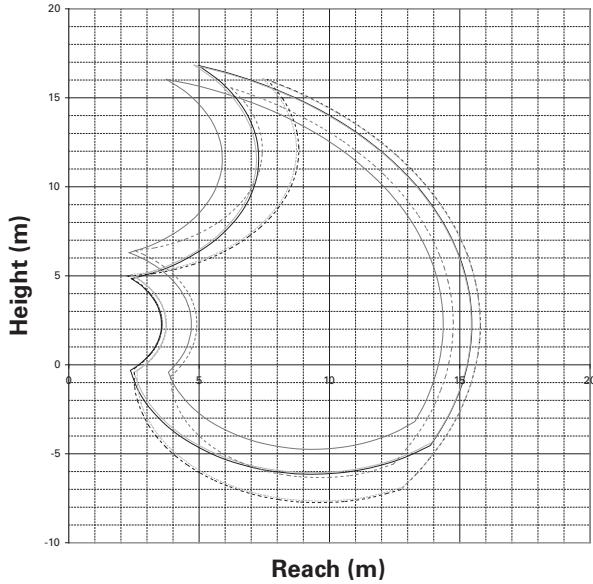

- Boom 9.3 m (30'6"), Stick 5.7 m (18'8")
- Boom 9.3 m (30'6"), Stick 7.1 m (23'4")
- Boom 9.3 m (30'6"), Straight 7.0 m (23'0")
- - - Barge Boom 9.9 m (32'6"), Stick 5.7 m (18'8")
- - - Barge Boom 9.9 m (32'6"), Stick 7.1 m (23'4")
- - - Barge Boom 9.9 m (32'6"), Straight 7.0 m (23'0")

M325D LMH Working Range

- Maximum Reach 14.4 m (47'3") or 15.5 m (50'10")

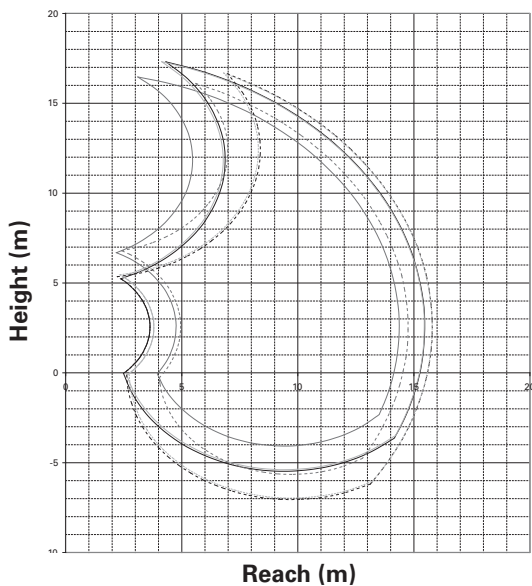

Material Handlers

Lifting Capacities

- M325D MH
(Ireland Sourced)

M325D MH — Lift Capacities — 5700 mm/18'8"

With 9300 mm/30'6" boom and 5700 mm/18'8" MH stick.

BOOM — 9300 mm **STICK** — 5700 mm **COUNTERWEIGHT** — 5800 kg

Metric Units/all weights are in kg

Radius of lift point (center line of the bucket pivot mounting pin) from Swing bearing (m)

Undercarriage configuration	3.0 m		4.5 m		6.0 m		7.5 m		9.0 m		10.5 m		12.0 m		13.5 m		m		
15.0 m					*6150	*6150											*5600	*5600	6.47
ER Stabilizers up					*6150	*6150											*5600	*5600	
ER Stabilizers down																			
12.0 m					*8400	8000	7250	5550	5300	4000	3950	2900					3950	2900	10.52
ER Stabilizers up					*8400	*8400	*7650	*7650	*6500	*6500	*4500	*4500					*4450	*4450	
ER Stabilizers down																			
9.0 m					*9200	7700	7050	5350	5200	3900	3950	2950	3100	2200			2750	1950	12.68
ER Stabilizers up					*9200	*9200	*7800	*7800	*6800	*6800	*6050	*6050	*5400	5050			*4150	*4150	
ER Stabilizers down																			
6.0 m	*19 050	*19 050	*13 500	10 400	9000	6650	6350	4700	4750	3500	3700	2650	2950	2100	2350	1600	2200	1500	13.88
ER Stabilizers up	*19 050	*19 050	*13 500	*13 500	*10 350	*10 350	*8450	*8450	*7150	*7150	*6200	6100	*5450	4900	*4750	4000	*4200	3850	
ER Stabilizers down					7300	5100	5400	3800	4200	2950	3350	2300	2700	1850	2200	1500	2000	1300	
3.0 m					*11 450	*11 450	*9000	*9000	*7400	7150	*6250	5700	*5350	4650	*4600	3900	*4100	3500	14.36
ER Stabilizers up																			
ER Stabilizers down																			
0.0 m			*3000	*3000	6350	4150	4750	3150	3750	2500	3000	2000	2500	1650	2100	1400	1950	1250	14.20
ER Stabilizers up			*3000	*3000	*7000	*7000	*8500	*8500	*7000	6650	*5900	5350	*4950	4450	*4050	3750	*3550	3500	
ER Stabilizers down					6200	4050	4550	3000	3550	2350	2900	1900	2450	1600			2150	1400	
-3.0 m					*7300	*7300	*6600	*6600	*5600	*5600	*4700	*4700	*3800	*3800			*2750	*2750	13.38
ER Stabilizers up																			
ER Stabilizers down																			

BOOM — 30'6" **STICK** — 18'8" **COUNTERWEIGHT** — 12,787 lb

English Units/all weights are in lbs

Radius of lift point (center line of the bucket pivot mounting pin) from Swing bearing (ft)

Undercarriage configuration	10.0 ft		15.0 ft		20.0 ft		25.0 ft		30.0 ft		35.0 ft		40.0 ft		45.0 ft		ft			
50.0 ft			*16,000	*16,000													*12,800	*12,800	19.55	
ER Stabilizers up			*16,000	*16,000													*12,800	*12,800		
ER Stabilizers down																				
40.0 ft					*18,200	17,200	15,500	11,800	11,300	8500							8900	6600	33.89	
ER Stabilizers up					*18,200	*18,200	*16,500	*16,500	*13,600	*13,600							*9900	*9900		
ER Stabilizers down																				
30.0 ft					*19,900	16,700	15,200	11,500	11,200	8400	8500	6300	6600	4700			6100	4300	41.34	
ER Stabilizers up					*19,900	*19,900	*17,000	*17,000	*14,800	*14,800	*13,100	*13,100	*11,100	10,800			*9200	*9200		
ER Stabilizers down																				
20.0 ft	*38,100	*38,100	*29,100	22,500	19,500	14,400	13,700	10,200	10,300	7500	8000	5700	6300	4400	4000	5000	3400	4900	3400	45.44
ER Stabilizers up	*38,100	*38,100	*29,100	*29,100	*22,400	*22,400	*18,300	*18,300	*15,500	*15,500	*13,400	13,100	*11,800	10,500	*10,100	8600	*9200	8500		
ER Stabilizers down					15,800	11,000	11,700	8200	9000	6300	7200	5000	5800	4000	4800	3200	4400	2900		
10.0 ft					*24,800	*24,800	*19,500	*19,500	*16,000	15,400	*13,600	12,300	*11,600	10,000	*9800	8400	*9000	7800	47.11	
ER Stabilizers up																				
ER Stabilizers down																				
0.0 ft			*6900	*6900	13,700	9000	10,200	6800	8000	5400	6500	4400	5400	3600	4500	3000	4300	2800	46.59	
ER Stabilizers up			*6900	*6900	*16,300	*16,300	*18,400	*18,400	*15,200	14,300	*12,700	11,500	*10,600	9600	*8600	8100	*7800	7700		
ER Stabilizers down					13,400	8700	9800	6400	7700	5000	6300	4100	5300	3400			4700	3100		
-10.0 ft					*16,200	*16,200	*14,200	*14,200	*12,100	*12,100	*10,100	*10,100	*8,000	*8,000			*6100	*6100	43.83	
ER Stabilizers up																				
ER Stabilizers down																				

*Indicates that the load is limited by hydraulic lifting capacity rather than tipping load.

Oscillating axle needs to be locked. Weight of all lifting accessories must be subtracted from the lifting capacities. All lift capacities calculated and rated per ISO 10567:2007. Rated loads do not exceed 87% of hydraulic lift capacity or 75% of tipping load. Lifting capacities are based on the machine standing on a firm uniform supporting surface. The load point is the center line of the bucket pivot mounting pin on the stick. The use of a work tool attachment point to handle/lift objects, could affect the machine lift performance.

All lifts with heavy lift on. Always refer to the appropriate Operation and Maintenance Manual for specific product information.

M325D MH — Lift Capacities — 7100 mm/23'3"

With 9300 mm/30'6" boom and 7100 mm/23'3" MH stick.

BOOM — 9300 mm STICK — 7100 mm COUNTERWEIGHT — 5800 kg

Metric Units/all weights are in kg

Radius of lift point (center line of the bucket pivot mounting pin) from Swing bearing (m)

Lift Point Height (m)	Undercarriage configuration	3.0 m		4.5 m		6.0 m		7.5 m		9.0 m		10.5 m		12.0 m		13.5 m		15.0 m		m				
		ER up	ER down	ER up	ER down	ER up	ER down	ER up	ER down	ER up	ER down	ER up	ER down	ER up	ER down	ER up	ER down	ER up	ER down					
15.0 m	ER Stabilizers up ER Stabilizers down							*4900 *4900	*4900 *4900											*3900 *3900	*3900 *3900	8.66		
12.0 m	ER Stabilizers up ER Stabilizers down							*6400 *6400	*5950 *6400	5600 *5800	4300 *5800	4250 *4850	3200								*3250 *3350	*2350 *3350	11.98	
9.0 m	ER Stabilizers up ER Stabilizers down							*7100 *7100	5750 *6300	5500 *6300	4200 *5650	4200 *5650	3150	3250	2350	2550	1800				2350 *3200	1650 *3200	13.92	
6.0 m	ER Stabilizers up ER Stabilizers down					*9350 *9350	7350 *9350	6800 *7800	5100 *7800	5050 *6700	3750 *6700	3850 *6900	2850 *6900	3050 *6200	2200	2450	1700	1950	1300	1950	1300	1950	1300	15.02
3.0 m	ER Stabilizers up ER Stabilizers down			12 150 *14 850	8400 *14 850	*10 900 *10 900	7950 *8650	5650 *8650	5750 *7150	4100 *7150	4350 *7150	3100 *6100	3450 5800	2400	2750	1900	2250	1500	1850	1200	1750	1100	15.47	
0.0 m	ER Stabilizers up ER Stabilizers down	*2000 *2000	*2000 *2000	*4350 *4350	*4350 *4350	6500 *10 100	4300 *10 100	4800 *8700	3250 *7150	3750 *6250	3050 *6250	2000 5350	2000	2500	1650	2050	1300	1750	1100	1650	1050	1650	1050	15.32
-3.0 m	ER Stabilizers up ER Stabilizers down			*4650 *4650	*4650 *4650	6000 *7400	3850 *7400	4400 *7500	2850 *7500	3450 *6250	2200 *6250	2800 5100	1800	2300	1450	1950	1250				1750 *2800	1100 *2800	14.55	
-6.0 m	ER Stabilizers up ER Stabilizers down									3400 *4200	2200 *4200	2800 *3450	1800	5100	4350	4250								

BOOM — 30'6" STICK — 23'3" COUNTERWEIGHT — 12,787 lb

English Units/all weights are in lbs

Radius of lift point (center line of the bucket pivot mounting pin) from Swing bearing (ft)

Lift Point Height (ft)	Undercarriage configuration	10.0 ft		15.0 ft		20.0 ft		25.0 ft		30.0 ft		35.0 ft		40.0 ft		45.0 ft		50.0 ft		ft				
		ER up	ER down	ER up	ER down	ER up	ER down	ER up	ER down	ER up	ER down	ER up	ER down	ER up	ER down	ER up	ER down	ER up	ER down					
50.0 ft	ER Stabilizers up ER Stabilizers down							*10,200 *10,200	*10,200 *10,200												*8800 *8800	*8800 *8800	27.20	
40.0 ft	ER Stabilizers up ER Stabilizers down							*13,900 *13,900	12,800 *13,900	12,000 *12,400	9200 *12,400	9100 *10,100	6800								7300 *7400	5400 *7400	38.78	
30.0 ft	ER Stabilizers up ER Stabilizers down							*15,500 *15,500	12,400 *13,700	11,800 *13,700	9000 *12,300	9000 *12,300	6700	6900	5100	5400	3800				5300 *7100	3700 *7100	45.44	
20.0 ft	ER Stabilizers up ER Stabilizers down					*20,300 *20,300	15,900 *17,000	14,700 *17,000	11,000 *17,000	10,900 *14,600	8100 *14,600	8300 *12,800	6100	6500	4700	5200	3600	3800			4300 *7100	2900 *7100	49.18	
10.0 ft	ER Stabilizers up ER Stabilizers down			26,300 *32,100	18,300 *32,100	17,200 *23,600	12,300 *23,600	12,400 *18,700	8900 *18,700	9400 *15,500	6700 *15,500	7400	5200	5900	4100	4800	3200	3900	2500	3800	2400	3900	2400	50.72
0.0 ft	ER Stabilizers up ER Stabilizers down	*4500 *4500	*4500 *4500	*10,000 *10,000	*10,000 *10,000	14,000 *23,700	9300 *23,700	10,400 *18,900	7000 *18,900	8100 *15,500	5600 *14,400	4300 *13,000	3500	3500	2800	2800	2300	2300	2300	2300	3700 *7400	2300 *6800	50.26	
-10.0 ft	ER Stabilizers up ER Stabilizers down			*10,500 *10,500	*10,500 *10,500	12,900 *16,900	8300 *16,900	9500 *16,200	6100 *16,200	7400 *13,500	4800 *13,500	6000	3900	5000	3200	4200	2600				3900 *6200	2400 *6200	47.70	
-20.0 ft	ER Stabilizers up ER Stabilizers down									7400 *8900	4800 *8900													

*Indicates that the load is limited by hydraulic lifting capacity rather than tipping load.

Oscillating axle needs to be locked. Weight of all lifting accessories must be subtracted from the lifting capacities. All lift capacities calculated and rated per ISO 10567:2007. Rated loads do not exceed 87% of hydraulic lift capacity or 75% of tipping load. Lifting capacities are based on the machine standing on a firm uniform supporting surface. The load point is the center line of the bucket pivot mounting pin on the stick. The use of a work tool attachment point to handle/lift objects, could affect the machine lift performance.

All lifts with heavy lift on. Always refer to the appropriate Operation and Maintenance Manual for specific product information.

Material Handlers

Lifting Capacities

- M325D MH
(Ireland Sourced)

M325D MH — Lift Capacities — 7000 mm/22'11"

With 9300 mm/30'6" boom and 7000 mm/22'11" straight stick.

BOOM — 9300 mm **STICK** — 7000 mm **COUNTERWEIGHT** — 5800 kg

Metric Units/all weights are in kg

Radius of lift point (center line of the bucket pivot mounting pin) from Swing bearing (m)

Lift Height (m)	Undercarriage configuration	3.0 m		4.5 m		6.0 m		7.5 m		9.0 m		10.5 m		12.0 m		13.5 m		15.0 m		m		
		ER Up	ER Down	ER Up	ER Down	ER Up	ER Down	ER Up	ER Down	ER Up	ER Down	ER Up	ER Down	ER Up	ER Down	ER Up	ER Down	ER Up	ER Down			
15.0 m	ER Stabilizers up							*4650	*4650											*3650	*3650	8.61
	ER Stabilizers down							*4650	*4650											*3650	*3650	
12.0 m	ER Stabilizers up							*6200	5650	5300	4000	3900	2850							2900	2050	11.95
	ER Stabilizers down							*6200	*6200	*5550	*5550	*4600	*4600							*3050	*3050	
9.0 m	ER Stabilizers up							*6800	5450	5150	3850	3850	2800	2900	2050	2200	1450			2050	1300	13.89
	ER Stabilizers down							*6800	*6800	*6000	*6000	*5300	*5300	*4750	*4750	*3500	*3500			*2900	*2900	
6.0 m	ER Stabilizers up			*9750	*9750	*9100	7000	6450	4750	4700	3400	3550	2500	2700	1850	2100	1350			1600	950	14.99
	ER Stabilizers down			*9750	*9750	*9100	*9100	*7500	*7500	*6350	*6350	*5500	*5500	*4850	4700	*4250	3750			*2950	*2950	
3.0 m	ER Stabilizers up			11 650	7900	7550	5250	5350	3750	4000	2750	3100	2050	2400	1550	1900	1150	1500	850	1400	750	15.44
	ER Stabilizers down			*14 450	*14 450	*10 500	*10 500	*8250	*8250	*6800	*6800	*5700	5450	*4900	4350	*4200	3550	*3550	2950	*3100	2800	
0.0 m	ER Stabilizers up	*1500	*1500	*3850	*3850	6050	3850	4400	2850	3400	2150	2650	1650	2150	1250	1700	1000	1400	750	1350	700	15.29
	ER Stabilizers down	*1500	*1500	*3850	*3850	*9300	*9300	*8250	*8250	*6700	6350	*5550	5000	*4650	4050	*3900	3350	*3100	2850	*2950	2750	
-3.0 m	ER Stabilizers up			*4250	*4250	5550	3400	4000	2450	3050	1850	2450	1450	1950	1100	1600	900			1450	750	14.52
	ER Stabilizers down			*4250	*4250	*7000	*7000	*6950	*6950	*5750	*5750	*4750	4750	*3900	*3900	*3050	*3050			*2400	*2400	
-6.0 m	ER Stabilizers up									3050	1850											
	ER Stabilizers down									*3650	*3650											

BOOM — 30'6" **STICK** — 22'11" **COUNTERWEIGHT** — 12,787 lb

English Units/all weights are in lbs

Radius of lift point (center line of the bucket pivot mounting pin) from Swing bearing (ft)

Lift Height (ft)	Undercarriage configuration	10.0 ft		15.0 ft		20.0 ft		25.0 ft		30.0 ft		35.0 ft		40.0 ft		45.0 ft		50.0 ft		ft		
		ER Up	ER Down	ER Up	ER Down	ER Up	ER Down	ER Up	ER Down	ER Up	ER Down	ER Up	ER Down	ER Up	ER Down	ER Up	ER Down	ER Up	ER Down			
50.0 ft	ER Stabilizers up							*9600	*9600											*8300	*8300	27.03
	ER Stabilizers down							*9600	*9600											*8300	*8300	
40.0 ft	ER Stabilizers up							*13,400	12,100	11,300	8500	8300	6000							6600	4600	38.65
	ER Stabilizers down							*13,400	*13,400	*11,900	*11,900	*9500	*9500							*6800	*6800	
30.0 ft	ER Stabilizers up							*14,800	11,700	11,100	8300	8200	6000	6200	4300	4600	3000			4500	2900	45.31
	ER Stabilizers down							*14,800	*14,800	*13,000	*13,000	*11,600	*11,600	*10,300	*10,300	*6800	*6800			*6400	*6400	
20.0 ft	ER Stabilizers up					*19,600	15,200	13,900	10,300	10,100	7300	7600	5300	5800	3900	4400	2800			3600	2100	49.08
	ER Stabilizers down					*19,600	*19,600	*16,200	*16,200	*13,800	*13,800	*12,000	*12,000	*10,500	10,100	*9200	8100			*6500	*6500	
10.0 ft	ER Stabilizers up			25,200	17,200	16,300	11,400	11,600	8100	8600	5900	6600	4400	5200	3300	4000	2400	3200	1800	3100	1700	50.62
	ER Stabilizers down			*31,300	*31,300	*22,800	*22,800	*17,900	*17,900	*14,700	*14,700	*12,400	11,700	*10,600	9400	*9100	7700	*7600	6300	*6900	6200	
0.0 ft	ER Stabilizers up	*3400	*3400	*8800	13,000	8300	9500	6100	7300	4600	5700	3500	4600	2700	3700	2100	3000	1600	3000	1600	50.16	
	ER Stabilizers down	*3400	*3400	*8800	*8800	*21,900	*21,900	*17,900	*17,900	*14,500	13,600	*12,000	10,800	*10,100	8800	*8400	7200	*6500	6100	*6500		6100
-10.0 ft	ER Stabilizers up			*9600	*9600	11,900	7300	8600	5200	6600	4000	5200	3100	4200	2400	3500	1900			3200	1700	47.60
	ER Stabilizers down			*9600	*9600	*16,000	*16,000	*15,000	*15,000	*12,400	*12,400	*10,200	*10,200	*8300	*8300	*6400	*6400			*5200	*5200	
-20.0 ft	ER Stabilizers up																					
	ER Stabilizers down																					

*Indicates that the load is limited by hydraulic lifting capacity rather than tipping load.

Oscillating axle needs to be locked. Weight of all lifting accessories must be subtracted from the lifting capacities. All lift capacities calculated and rated per ISO 10567:2007. Rated loads do not exceed 87% of hydraulic lift capacity or 75% of tipping load. Lifting capacities are based on the machine standing on a firm uniform supporting surface. The load point is the center line of the bucket pivot mounting pin on the stick. The use of a work tool attachment point to handle/lift objects, could affect the machine lift performance.

All lifts with heavy lift on. Always refer to the appropriate Operation and Maintenance Manual for specific product information.

M325D LMH — Lift Capacities — 5700 mm/18'8"

With 9900 mm/32'6" barge boom and 5700 mm/18'8" MH stick.

BOOM — 9900 mm **STICK** — 5700 mm **COUNTERWEIGHT** — 7700 kg

Metric Units/all weights are in kg

Radius of lift point (center line of the bucket pivot mounting pin) from Swing bearing (m)

Lift Configuration	4.5 m		6.0 m		7.5 m		9.0 m		10.5 m		12.0 m		13.5 m		15.0 m		m
	ER up	ER down	ER up	ER down	ER up	ER down	ER up	ER down	ER up	ER down	ER up	ER down	ER up	ER down	ER up	ER down	
15.0 m					6000	6000									5550	5550	7.78
13.5 m					7700	7500	6350	5500							5050	4700	9.81
12.0 m					7650	7550	6900	5550	5600	4200					4800	3650	11.29
10.5 m					7750	7450	6950	5500	5600	4200	4400	3250			4700	3000	12.41
9.0 m			9400	9400	8050	7200	7100	5350	5500	4100	4350	3200			3600	2600	13.26
7.5 m			10 200	9600	8500	6800	6800	5100	5350	3950	4250	3100	3450	2450	3250	2300	13.90
6.0 m			11 200	8700	8550	6300	6500	4750	5100	3750	4150	3000	3400	2400	3000	2100	14.36
4.5 m			10 850	7700	7950	5700	6100	4400	4900	3500	4000	2850	3300	2300	2850	1950	14.64
3.0 m			9850	6800	7350	5200	5750	4100	4650	3300	3800	2700	3200	2200	2750	1900	14.77
1.5 m			7600	6200	6900	4750	5450	3800	4450	3100	3700	2550	3100	2100	2700	1850	14.74
0.0 m	3450	3450	6950	5900	6600	4500	5250	3550	4250	2900	3550	2450	3000	2050	2700	1850	14.55
-1.5 m	4650	4650	7300	5800	6450	4350	5100	3450	4150	2800	3500	2350	3000	2000	2800	1850	14.21
-3.0 m			7900	5800	6400	4300	5050	3400	4100	2750	3450	2350	2950	2000	2900	1950	13.69
-4.5 m					6450	4350	5050	3400	4100	2800	3450	2350			3150	2150	12.97

Oscillating axle needs to be locked. Weight of all lifting accessories must be subtracted from the lifting capacities. All lift capacities calculated and rated per ISO 10567:2007. Rated loads do not exceed 87% of hydraulic lift capacity or 75% of tipping load. Lifting capacities are based on the machine standing on a firm uniform supporting surface. The load point is the center line of the bucket pivot mounting pin on the stick. The use of a work tool attachment point to handle/lift objects, could affect the machine lift performance.

All lifts with heavy lift on. Always refer to the appropriate Operation and Maintenance Manual for specific product information.

M325D LMH — Lift Capacities — 5700 mm/18'8"

With 9900 mm/32'6" barge boom and 5700 mm/18'8" MH stick.



















BOOM — 32'6"

STICK — 18'8"

COUNTERWEIGHT — 16,976 lb

English Units/all weights are in lbs

Radius of lift point (center line of the bucket pivot mounting pin) from Swing bearing (ft)

	Undercarriage configuration	15.0 ft		20.0 ft		25.0 ft		30.0 ft		35.0 ft		40.0 ft		45.0 ft				m
																		
50.0 ft	ER Stabilizers up					13,230	13,230									12,235	12,235	25.52
	ER Stabilizers down					13,230	13,230									12,235	12,235	
45.0 ft	ER Stabilizers up					16,975	16,535	14,000	12,125							11,135	10,360	32.18
	ER Stabilizers down					16,975	16,975	14,000	14,000							11,135	11,135	
40.0 ft	ER Stabilizers up					16,865	16,645	15,210	12,235	12,345	9260					10,580	8045	37.03
	ER Stabilizers down					16,865	16,865	15,210	15,210	13,780	13,780					10,580	10,580	
35.0 ft	ER Stabilizers up					17,085	16,425	15,320	12,125	12,345	9260	9700	7165			9040	6615	40.70
	ER Stabilizers down					17,085	17,085	15,320	15,320	13,890	13,890	12,345	12,345			10,360	10,360	
30.0 ft	ER Stabilizers up			20,725	20,725	17,745	15,875	15,655	11,795	12,125	9040	9590	7055			7935	5730	43.49
	ER Stabilizers down			20,725	20,725	17,745	17,745	15,655	15,655	14,110	14,110	12,785	12,785			10,250	10,250	
25.0 ft	ER Stabilizers up			22,485	21,165	18,740	14,990	14,990	11,245	11,795	8710	9370	6835	7605	5400	7165	5070	45.59
	ER Stabilizers down			22,485	22,485	18,740	18,740	16,315	16,315	14,440	14,440	13,010	13,010	11,795	11,795	10,360	10,360	
20.0 ft	ER Stabilizers up			24,690	19,180	18,850	13,890	14,330	10,470	11,245	8265	9150	6615	7495	5290	6615	4630	47.10
	ER Stabilizers down			24,690	24,690	20,060	20,060	16,975	16,975	14,880	14,880	13,230	13,230	11,795	11,795	10,580	10,580	
15.0 ft	ER Stabilizers up			23,920	16,975	17,525	12,565	13,450	9700	10,800	7715	8820	6285	7275	5070	6285	4300	48.02
	ER Stabilizers down			26,895	26,895	21,275	21,275	17,745	17,745	15,210	15,210	13,340	13,340	11,905	11,685	10,800	10,250	
10.0 ft	ER Stabilizers up			21,715	14,990	16,205	11,465	12,675	9040	10,250	7275	8375	5950	7055	4850	6065	4190	48.45
	ER Stabilizers down			25,575	25,575	22,155	22,155	18,190	18,190	15,540	15,540	13,450	13,450	11,795	11,465	10,470	10,030	
5.0 ft	ER Stabilizers up			16,755	13,670	15,210	10,470	12,015	8375	9810	6835	8155	5620	6835	4630	5950	4080	48.35
	ER Stabilizers down			16,755	16,755	22,265	22,265	18,410	18,410	15,540	15,540	13,450	13,340	11,685	11,245	10,250	9920	
0.0 ft	ER Stabilizers up	7605	7605	15,320	13,005	14,550	9920	11,575	7825	9370	6395	7825	5400	6615	4520	5950	4080	47.72
	ER Stabilizers down	7605	7605	15,320	15,320	21,715	21,715	18,080	18,080	15,320	15,320	13,115	13,115	11,245	11,135	9920	9920	
-5.0 ft	ER Stabilizers up	4650	4650	16,095	12,785	14,220	9590	11,245	7605	9150	6175	7715	5180	6615	4410	6175	4080	46.61
	ER Stabilizers down	4650	4650	16,095	16,095	20,500	20,500	17,195	17,195	14,550	14,550	12,455	12,455	10,470	10,470	9480	9480	
-10.0 ft	ER Stabilizers up			17,415	12,785	14,110	9480	11,135	7495	9040	6065	7605	5180	6505	4410	6395	4300	44.90
	ER Stabilizers down			17,415	17,415	18,520	18,520	15,765	15,765	13,450	13,450	11,355	11,355	9150	9150	8930	8930	
-15.0 ft	ER Stabilizers up			14,220	9590	11,135	7495	9040	6175	7605	5180					6945	4740	42.54
	ER Stabilizers down			15,875	15,875	13,780	13,780	11,685	11,685	9590	9590					8155	8155	

Oscillating axle needs to be locked. Weight of all lifting accessories must be subtracted from the lifting capacities. All lift capacities calculated and rated per ISO 10567:2007. Rated loads do not exceed 87% of hydraulic lift capacity or 75% of tipping load. Lifting capacities are based on the machine standing on a firm uniform supporting surface. The load point is the center line of the bucket pivot mounting pin on the stick. The use of a work tool attachment point to handle/lift objects, could affect the machine lift performance.

All lifts with heavy lift on. Always refer to the appropriate Operation and Maintenance Manual for specific product information.

M325D LMH — Lift Capacities — 7100 mm/23'3"

With 9900 mm/32'6" barge boom and 7100 mm/23'3" MH stick.

BOOM — 9900 mm **STICK** — 7100 mm **COUNTERWEIGHT** — 7700 kg

Metric Units/all weights are in kg

Radius of lift point (center line of the bucket pivot mounting pin) from Swing bearing (m)

Lift Height (m)	Undercarriage configuration	3.0 m		4.5 m		6.0 m		7.5 m		9.0 m		10.5 m		12.0 m		13.5 m		15.0 m		Lift Capacity (kg)		Lift Height (m)		
		ER up	ER down	ER up	ER down	ER up	ER down	ER up	ER down	ER up	ER down	ER up	ER down	ER up	ER down	ER up	ER down	ER up	ER down	ER up	ER down			
16.5 m	ER Stabilizers up																				4650	4650	7.22	
	ER Stabilizers down																				4650	4650		
15.0 m	ER Stabilizers up									4750	4750											4100	4100	9.62
	ER Stabilizers down									4750	4750											4100	4100	
13.5 m	ER Stabilizers up									6000	5900	4750	4450									3800	3800	11.33
	ER Stabilizers down									6000	6000	4750	4750									3800	3800	
12.0 m	ER Stabilizers up									6200	5900	5750	4500	4500	3450							3700	3100	12.63
	ER Stabilizers down									6200	6200	5750	5750	4500	4500							3700	3700	
10.5 m	ER Stabilizers up									6300	5850	5800	4450	4600	3450	3700	2700					3600	2600	13.63
	ER Stabilizers down									6300	6300	5800	5800	5350	5350	3850	3850					3600	3600	
9.0 m	ER Stabilizers up									6500	5650	5750	4350	4550	3400	3650	2650					3200	2300	14.42
	ER Stabilizers down									6500	6500	5900	5900	5400	5400	5000	5000					3600	3600	
7.5 m	ER Stabilizers up								7700	7300	6800	5400	5550	4150	4450	3250	3600	2600	2900	2050		2900	2050	15.01
	ER Stabilizers down								7700	7700	6800	6800	6100	6100	5500	5500	5050	5050	3650	3650		3650	3650	
6.0 m	ER Stabilizers up			12 600	12 600	9950	9600	8300	6800	6800	6800	5050	5350	3950	4250	3100	3500	2500	2850	2000		2700	1850	15.43
	ER Stabilizers down			12 600	12 600	9950	9950	8300	8300	7150	7150	6300	6300	5650	5650	5100	5100	4600	4600			3750	3750	
4.5 m	ER Stabilizers up			14 850	13 000	11 100	8550	8450	6150	6400	4700	5050	3650	4100	2950	3350	2350	2800	1900		2550	1750	15.69	
	ER Stabilizers down			14 850	14 850	11 100	11 100	8950	8950	7550	7550	6550	6550	5800	5800	5200	5200	4650	4550			3850		3850
3.0 m	ER Stabilizers up			9200	9200	10 600	7450	7750	5550	6000	4300	4750	3400	3900	2750	3200	2250	2700	1850		2450	1650	15.81	
	ER Stabilizers down			9200	9200	12 050	12 050	9500	9500	7900	7900	6750	6750	5900	5900	5250	5250	4650	4450			4000		4000
1.5 m	ER Stabilizers up			5150	5150	9650	6550	7150	5000	5600	3900	4500	3150	3700	2550	3100	2100	2600	1750		2400	1600	15.78	
	ER Stabilizers down			5150	5150	12 600	12 600	9850	9850	8100	8100	6900	6900	5950	5950	5250	5150	4600	4350			4250		4050
0.0 m	ER Stabilizers up	2600	2600	4650	4650	8900	6000	6700	4550	5300	3600	4300	2950	3550	2400	3000	2000	2550	1700		2400	1600	15.61	
	ER Stabilizers down	2600	2600	4650	4650	8900	8900	9900	9900	8150	8150	6900	6900	5950	5950	5150	5000	4450	4300			4150		4050
-1.5 m	ER Stabilizers up	3450	3450	4950	4950	7900	5700	6400	4300	5050	3400	4100	2750	3450	2300	2900	1950	2500	1650		2450	1600	15.29	
	ER Stabilizers down	3450	3450	4950	4950	7900	7900	9650	9650	8000	8000	6750	6750	5800	5800	4950	4900	4200	4200			4050		4050
-3.0 m	ER Stabilizers up			5350	5350	7750	5550	6250	4150	4900	3250	4000	2650	3350	2200	2850	1900					2500	1650	14.81
	ER Stabilizers down			5350	5350	7750	7750	9050	9050	7600	7600	6400	6400	5450	5450	4650	4650					3900	3900	
-4.5 m	ER Stabilizers up			5850	5850	7950	5550	6200	4100	4850	3200	3950	2600	3300	2200	2850	1850					2700	1750	14.15
	ER Stabilizers down			5850	5850	7950	7950	8200	8200	6950	6950	5900	5900	4950	4950	4100	4100					3700	3700	
-6.0 m	ER Stabilizers up					8100	5650	6250	4150	4850	3250	2650	2650	3350	2200							2950	1950	13.29
	ER Stabilizers down					8100	8100	7000	7000	6000	6000	5100	5100	4200	4200							3400	3400	

Oscillating axle needs to be locked. Weight of all lifting accessories must be subtracted from the lifting capacities. All lift capacities calculated and rated per ISO 10567:2007. Rated loads do not exceed 87% of hydraulic lift capacity or 75% of tipping load. Lifting capacities are based on the machine standing on a firm uniform supporting surface. The load point is the center line of the bucket pivot mounting pin on the stick. The use of a work tool attachment point to handle/lift objects, could affect the machine lift performance.

All lifts with heavy lift on. Always refer to the appropriate Operation and Maintenance Manual for specific product information.

Material Handlers

Lifting Capacities ● M325D LMH (Ireland Sourced)

M325D LMH — Lift Capacities — 7100 mm/23'3"

With 9900 mm/32'6" barge boom and 7100 mm/23'3" MH stick.

BOOM — 32'6"

STICK — 23'3"

COUNTERWEIGHT — 16,976 lb

English Units/all weights are in lbs

Radius of lift point (center line of the bucket pivot mounting pin) from Swing bearing (ft)

Stick Length	Undercarriage configuration	10.0 ft		15.0 ft		20.0 ft		25.0 ft		30.0 ft		35.0 ft		40.0 ft		45.0 ft		50.0 ft		m			
		ER Stabilizers up	ER Stabilizers down	ER Stabilizers up	ER Stabilizers down	ER Stabilizers up	ER Stabilizers down	ER Stabilizers up	ER Stabilizers down	ER Stabilizers up	ER Stabilizers down	ER Stabilizers up	ER Stabilizers down	ER Stabilizers up	ER Stabilizers down	ER Stabilizers up	ER Stabilizers down	ER Stabilizers up	ER Stabilizers down	ER Stabilizers up	ER Stabilizers down	ER Stabilizers up	ER Stabilizers down
55.0 ft	ER Stabilizers up																				10,250	10,250	23.68
	ER Stabilizers down																				10,250	10,250	
50.0 ft	ER Stabilizers up									10,470	10,470										9040	9040	31.55
	ER Stabilizers down									10,470	10,470										9040	9040	
45.0 ft	ER Stabilizers up									13,230	13,010	10,470	9810								8380	8380	37.16
	ER Stabilizers down									13,230	13,203	10,470	10,470								8380	8380	
40.0 ft	ER Stabilizers up									13,670	13,010	12,675	9920	9920	7605						6835	6835	41.43
	ER Stabilizers down									13,670	13,670	12,675	12,675	9920	9920						8160	8160	
35.0 ft	ER Stabilizers up									13,890	12,895	12,785	9810	10,140	7605	8160	5950				7940	5730	44.71
	ER Stabilizers down									13,890	13,890	12,785	12,875	11,795	11,795	8490	8490				7940	7940	
30.0 ft	ER Stabilizers up									14,330	12,455	12,675	9590	10,030	7495	8045	5840				7055	5070	47.30
	ER Stabilizers down									14,330	14,330	13,010	13,010	11,905	11,905	11,025	11,025				7940	7940	
25.0 ft	ER Stabilizers up							16,975	16,095	14,990	11,905	12,235	9150	9810	7165	7935	5730	6395	4520	6395	4520	49.23	
	ER Stabilizers down							16,975	16,975	14,990	14,990	13,450	13,450	12,125	12,125	11,135	11,135	8045	8045	8050	8050		
20.0 ft	ER Stabilizers up			27,780	27,780	21,935	21,165	18,300	14,990	14,990	11,135	11,795	8710	9370	6835	7715	5510	6285	4410	5950	4080	50.61	
	ER Stabilizers down			27,780	27,780	21,935	21,935	18,300	18,300	15,760	15,760	13,890	13,890	12,455	12,455	11,245	11,245	10,140	10,140	8270	8270		
15.0 ft	ER Stabilizers up			32,740	28,660	24,470	18,850	18,630	13,560	14,110	10,360	11,135	8045	9040	6505	7385	5180	6170	4190	5620	3860	51.46	
	ER Stabilizers down			32,740	32,740	24,470	24,470	19,730	19,730	16,645	16,645	14,440	14,440	12,785	12,785	11,465	11,465	10,250	10,030	8490	8490		
10.0 ft	ER Stabilizers up			20,280	20,280	23,370	16,425	17,085	12,235	13,230	9480	10,470	7495	8600	6060	7055	4960	5950	4080	5400	3640	51.86	
	ER Stabilizers down			20,280	20,280	26,565	26,565	20,945	20,945	17,415	17,415	14,880	14,880	13,010	13,010	11,575	11,575	10,250	9810	8820	8820		
5.0 ft	ER Stabilizers up			11,355	11,355	21,275	14,440	15,760	11,025	12,345	8600	9920	6945	8160	5620	6835	4630	5730	3860	5290	3530	51.76	
	ER Stabilizers down			11,355	11,355	27,780	27,780	21,715	21,715	17,860	17,860	15,210	15,210	13,120	13,120	11,575	11,355	10,140	9590	9370	8930		
0.0 ft	ER Stabilizers up	5730	5730	10,250	10,250	19,620	13,230	14,770	10,030	11,685	7935	9480	6505	7825	5290	6615	4410	5620	3750	5290	3530	51.20	
	ER Stabilizers down	5730	5730	10,250	10,250	19,620	19,620	21,825	21,825	17,970	17,970	15,210	15,210	13,120	13,120	11,355	11,025	9810	9480	9150	8930		
-5.0 ft	ER Stabilizers up	7605	7605	10,910	10,910	17,415	12,565	14,110	9480	11,135	7495	9040	6060	7605	5070	6395	4300	5510	3640	5400	3530	50.15	
	ER Stabilizers down	7605	7605	10,910	10,910	17,415	17,415	21,275	21,275	17,635	17,635	14,880	14,880	12,785	12,785	10,910	10,800	9260	9260	8930	8930		
-10.0 ft	ER Stabilizers up			11,795	11,795	17,085	12,235	13,780	9150	10,800	7165	8820	5840	7385	4850	6285	4190			5510	3640	48.58	
	ER Stabilizers down			11,795	11,795	17,085	17,085	19,950	19,950	16,755	16,755	14,110	14,110	12,015	12,015	10,250	10,250			8600	8600		
-15.0 ft	ER Stabilizers up			12,895	12,895	17,525	12,235	13,670	9040	10,690	7055	8710	5730	7275	4850	6285	4080			5950	3860	46.41	
	ER Stabilizers down			12,895	12,895	17,525	17,525	18,080	18,080	15,320	15,320	13,010	13,010	10,910	10,910	9040	9040			8160	8160		
-20.0 ft	ER Stabilizers up					17,860	12,455	13,780	9150	10,690	7165	5840	5840	7385	4850					6505	4300	43.59	
	ER Stabilizers down					17,860	17,860	15,430	15,430	13,230	13,230	11,245	11,245	9260	9260					7495	7495		

Oscillating axle needs to be locked. Weight of all lifting accessories must be subtracted from the lifting capacities. All lift capacities calculated and rated per ISO 10567:2007. Rated loads do not exceed 87% of hydraulic lift capacity or 75% of tipping load. Lifting capacities are based on the machine standing on a firm uniform supporting surface. The load point is the center line of the bucket pivot mounting pin on the stick. The use of a work tool attachment point to handle/lift objects, could affect the machine lift performance.

All lifts with heavy lift on. Always refer to the appropriate Operation and Maintenance Manual for specific product information.

M325D LMH — Lift Capacities — 5700 mm/18'8"

With 9300 mm/30'6" boom and 5700 mm/18'8" MH stick.

BOOM — 9300 mm STICK — 5700 mm COUNTERWEIGHT — 7700 kg

Metric Units/all weights are in kg

Radius of lift point (center line of the bucket pivot mounting pin) from Swing bearing (m)

Undercarriage configuration	4.5 m		6.0 m		7.5 m		9.0 m		10.5 m		12.0 m		13.5 m		m		
15.0 m			*7750	*7750										*6350	*6350	7.01	
WER Stabilizers up														*6350	*6350		
WER Stabilizers down																	
12.0 m			*10 100	*10 100	8750	7350	6500	5450	4950	4100					4700	3900	10.78
WER Stabilizers up														*5200	*5200		
WER Stabilizers down																	
9.0 m			*10 750	10 150	8500	7100	6350	5300	4950	4100	3900	3200			3450	2800	12.83
WER Stabilizers up														*4950	*4950		
WER Stabilizers down																	
6.0 m	*16 100	13 800	10 850	8950	7750	6400	5900	4850	4650	3800	3750	3050	3050	2450	2900	2300	13.96
WER Stabilizers up														*5000	*5000		
WER Stabilizers down																	
3.0 m			9150	7300	6800	5500	5300	4300	4250	3450	3500	2800	2950	2350	2650	2100	14.38
WER Stabilizers up														*4900	*4900		
WER Stabilizers down																	
0.0 m	*3950	*3950	8250	6450	6150	4850	4850	3850	3950	3150	3300	2650	2800	2250	2650	2100	14.16
WER Stabilizers up														*4800	*4800		
WER Stabilizers down																	
-3.0 m					6000	4700	4700	3700	3850	3050	3250	2550					
WER Stabilizers up																	
WER Stabilizers down					*7750	*7750	*6600	*6600	*5550	*5550	*4450	*4450					

BOOM — 30'6" STICK — 18'8" COUNTERWEIGHT — 16,976 lb

English Units/all weights are in lbs

Radius of lift point (center line of the bucket pivot mounting pin) from Swing bearing (ft)

Undercarriage configuration	15.0 ft		20.0 ft		25.0 ft		30.0 ft		35.0 ft		40.0 ft		45.0 ft		ft		
50.0 ft	*19,600	*19,600	*16,000	*16,000										*14,500	*14,500	21.49	
WER Stabilizers up														*14,500	*14,500		
WER Stabilizers down																	
40.0 ft			*21,900	*21,900	18,800	15,800	13,900	11,600							10,700	8900	34.81
WER Stabilizers up														*11,600	*11,600		
WER Stabilizers down																	
30.0 ft			*23,300	21,900	18,300	15,400	13,700	11,400	10,600	8800	8400	6900			7700	6300	41.86
WER Stabilizers up														*10,900	*10,900		
WER Stabilizers down																	
20.0 ft	*34,700	29,900	23,500	19,400	16,800	13,900	12,700	10,500	10,000	8200	8100	6600	6600	5300	6400	5100	45.73
WER Stabilizers up														*11,000	*11,000		
WER Stabilizers down																	
10.0 ft			19,800	15,800	14,700	11,900	11,400	9300	9200	7400	7600	6100	6300	5000	5800	4600	47.18
WER Stabilizers up														*10,800	*10,800		
WER Stabilizers down																	
0.0 ft	*9100	*9100	17,800	13,900	13,300	10,500	10,500	8300	8500	6800	7100	5700	6100	4800	5800	4600	46.46
WER Stabilizers up														*9400	*9400		
WER Stabilizers down																	
-10.0 ft					12,900	10,200	10,200	8000	8300	6600	7000	5600					
WER Stabilizers up																	
WER Stabilizers down					*16,800	*16,800	*14,300	*14,300	*11,900	*11,900	*9400	*9400					

*Indicates that the load is limited by hydraulic lifting capacity rather than tipping load.

Oscillating axle needs to be locked. Weight of all lifting accessories must be subtracted from the lifting capacities. All lift capacities calculated and rated per ISO 10567:2007. Rated loads do not exceed 87% of hydraulic lift capacity or 75% of tipping load. Lifting capacities are based on the machine standing on a firm uniform supporting surface. The load point is the center line of the bucket pivot mounting pin on the stick. The use of a work tool attachment point to handle/lift objects, could affect the machine lift performance.

All lifts with heavy lift on. Always refer to the appropriate Operation and Maintenance Manual for specific product information.

Material Handlers

Lifting Capacities ● M325D LMH (Ireland Sourced)

M325D LMH — Lift Capacities — 7100 mm/23'3"

With 9300 mm/30'6" boom and 7100 mm/23'3" MH stick.

BOOM — 9300 mm **STICK** — 7100 mm **COUNTERWEIGHT** — 7700 kg

Metric Units/all weights are in kg

Radius of lift point (center line of the bucket pivot mounting pin) from Swing bearing (m)

Undercarriage configuration	4.5 m		6.0 m		7.5 m		9.0 m		10.5 m		12.0 m		13.5 m		15.0 m		m			
15.0 m					*6100	*6100	*4650	*4650									*4550	*4550	9.08	
WER Stabilizers up					*6100	*6100	*4650	*4650									*4550	*4550		
WER Stabilizers down																				
12.0 m					*7750	*7750	6850	5750	5250	4400	4100	3400						3950	3250	12.22
WER Stabilizers up					*7750	*7750	*7050	*7050	*6000	*6000	*4300	*4300						*3950	*3950	
WER Stabilizers down																				
9.0 m					*8350	7550	6650	5600	5150	4300	4050	3350	3250	2650				3000	2450	14.06
WER Stabilizers up					*8350	*8350	*7450	*7450	*6700	*6700	*6100	*6100	*4800	*4800				*3800	*3800	
WER Stabilizers down																				
6.0 m	*12 500	*12 500	*11 100	9700	8200	6850	6150	5150	4800	4000	3850	3150	3150	2550	2550	2050	2550	2050	15.09	
WER Stabilizers up	*12 500	*12 500	*11 100	*11 100	*9250	*9250	*8000	*8000	*7000	*7000	*6250	*6250	*5600	5550	*4100	*4100	*3900	*3900		
WER Stabilizers down																				
3.0 m	14 850	11 700	9750	7900	7100	5800	5500	4450	4350	3550	3550	2850	2950	2350	2450	1950	2350	1850	15.48	
WER Stabilizers up	*17 750	*17 750	*13 000	*13 000	*10 300	*10 300	*8550	*8550	*7300	*7300	*6350	*6350	*5550	5350	*4800	4550	*4150	*4150		
WER Stabilizers down																				
0.0 m	*5350	*5350	8350	6550	6200	4900	4900	3900	3950	3150	3300	2600	2750	2150	2350	1850	2300	1800	15.28	
WER Stabilizers up	*5350	*5350	*11 650	*10 400	*10 400	*8550	*8550	*7200	*7200	*6100	*6100	*5200	*5200	*4250	*4250	*4100	*4100			
WER Stabilizers down																				
-3.0 m	*5900	*5900	7900	6100	5800	4550	4550	3600	3750	2950	3150	2450	2700	2100			2450	1900	14.46	
WER Stabilizers up	*5900	*5900	*9150	*9150	*8850	*8850	*7400	*7400	*6200	*6200	*5200	*5200	*4200	*4200			*3450	*3450		
WER Stabilizers down																				

BOOM — 30'6" **STICK** — 23'3" **COUNTERWEIGHT** — 16,976 lb

English Units/all weights are in lbs

Radius of lift point (center line of the bucket pivot mounting pin) from Swing bearing (ft)

Undercarriage configuration	15.0 ft		20.0 ft		25.0 ft		30.0 ft		35.0 ft		40.0 ft		45.0 ft		50.0 ft		ft			
50.0 ft			*15,200	*15,200	*12,700	*12,700											*10,200	*10,200	28.64	
WER Stabilizers up			*15,200	*15,200	*12,700	*12,700											*10,200	*10,200		
WER Stabilizers down																				
40.0 ft					*16,800	16,800	14,600	12,400	11,200	9400								8800	7300	39.57
WER Stabilizers up					*16,800	*16,800	*15,100	*15,100	*12,500	*12,500								*8800	*8800	
WER Stabilizers down																				
30.0 ft					*18,200	16,300	14,300	12,100	11,100	9200	8700	7200	7000	5700				6700	5400	45.90
WER Stabilizers up					*18,200	*18,200	*16,200	*16,200	*14,600	*14,600	*13,300	*13,300	*9500	*9500				*8400	*8400	
WER Stabilizers down																				
20.0 ft	*27,100	*27,100	*24,000	21,000	17,700	14,800	13,300	11,100	10,400	8600	8300	6800	6700	5400				5600	4500	49.44
WER Stabilizers up	*27,100	*27,100	*24,000	*24,000	*20,100	*20,100	*17,300	*17,300	*15,200	*15,200	*13,600	*13,600	*12,100	12,000				*8500	*8500	
WER Stabilizers down																				
10.0 ft	32,100	25,300	21,100	17,100	15,400	12,500	11,800	9600	9400	7600	7700	6200	6300	5000	5300	4200	5100	4000	50.79	
WER Stabilizers up	*38,400	*38,400	*28,200	*28,200	*22,400	*22,400	*18,600	*18,600	*15,900	*15,900	*13,800	*13,800	*12,000	11,500	*10,300	9800	*9100	*9100		
WER Stabilizers down																				
0.0 ft	*12,300	*12,300	18,000	14,100	13,400	10,600	10,500	8400	8500	6800	7100	5600	5900	4700	5100	4000	5100	3900	50.13	
WER Stabilizers up	*12,300	*12,300	*27,200	*27,200	*22,500	*22,500	*18,500	*18,500	*15,500	*15,500	*13,200	13,100	*11,200	11,100	*9100	*9100	*9000	*9000		
WER Stabilizers down																				
-10.0 ft	*13,300	*13,300	17,000	13,200	12,600	9800	9900	7700	8100	6300	6700	5300	5800	4500				5400	4200	47.38
WER Stabilizers up	*13,300	*13,300	*20,900	*20,900	*19,200	*19,200	*16,000	*16,000	*13,400	*13,400	*11,100	*11,100	*8800	*8800				*7600	*7600	
WER Stabilizers down																				

*Indicates that the load is limited by hydraulic lifting capacity rather than tipping load.

Oscillating axle needs to be locked. Weight of all lifting accessories must be subtracted from the lifting capacities. All lift capacities calculated and rated per ISO 10567:2007. Rated loads do not exceed 87% of hydraulic lift capacity or 75% of tipping load. Lifting capacities are based on the machine standing on a firm uniform supporting surface. The load point is the center line of the bucket pivot mounting pin on the stick. The use of a work tool attachment point to handle/lift objects, could affect the machine lift performance.

All lifts with heavy lift on. Always refer to the appropriate Operation and Maintenance Manual for specific product information.

M325D LMH — Lift Capacities — 7000 mm/22'11"

With 9300 mm/30'6" boom and 7000 mm/22'11" straight stick.

BOOM — 9300 mm STICK — 7000 mm COUNTERWEIGHT — 7700 kg

Metric Units/all weights are in kg

Radius of lift point (center line of the bucket pivot mounting pin) from Swing bearing (m)

Lift Height	Undercarriage configuration	3.0 m		4.5 m		6.0 m		7.5 m		9.0 m		10.5 m		12.0 m		13.5 m		15.0 m		m		
		WER up	WER down	WER up	WER down	WER up	WER down	WER up	WER down	WER up	WER down	WER up	WER down	WER up	WER down	WER up	WER down	WER up	WER down			
15.0 m	WER Stabilizers up							*5850	*5850	*4350	*4350									*4300	*4300	9.02
	WER Stabilizers down							*5850	*5850	*4350	*4350									*4300	*4300	
12.0 m	WER Stabilizers up							*7550	7500	6500	5450	4900	4050	3750	3050					3600	2950	12.18
	WER Stabilizers down							*7550	*7550	*6850	*6850	*5750	*5750	*4000	*4000					*3700	*3700	
9.0 m	WER Stabilizers up							*8050	7250	6350	5250	4800	3950	3750	3050	2900	2300			2650	2100	14.03
	WER Stabilizers down							*8050	*8050	*7100	*7100	*6350	*6350	*5750	*5750	*4500	*4500			*3550	*3550	
6.0 m	WER Stabilizers up			*12500	*12500	*10800	9350	7850	6500	5800	4800	4450	3650	3500	2800	2800	2200	2250	1700	2200	1700	15.06
	WER Stabilizers down			*12500	*12500	*10800	*10800	*8950	*8950	*7650	*7650	*6650	*6650	*5850	*5850	*5200	*5200	*3750	*3750	*3600	*3600	
3.0 m	WER Stabilizers up			14300	11150	9350	7450	6750	5400	5100	4100	4000	3200	2500	2600	2000	2100	1600	2000	1500	1500	15.45
	WER Stabilizers down			*15650	*15650	*12650	*12650	*9950	*9950	*8200	*8200	*6900	*6900	*5950	*5950	*5150	5000	*4350	4200	*3850	*3850	
0.0 m	WER Stabilizers up	*2200	*2200	*4800	*4800	7900	6100	5800	4500	4500	3500	3600	2800	2900	2250	2400	1800	2000	1500	1950	1450	15.25
	WER Stabilizers down	*2200	*2200	*4800	*4800	*10850	*10850	*9900	*9900	*8100	*8100	*6750	*6750	*5700	*5700	*4750	*4750	*3850	*3850	*3650	*3650	
-3.0 m	WER Stabilizers up			*5500	*5500	7450	5700	5400	4150	4200	3200	3350	2550	2750	2100	2350	1750			2100	1600	14.43
	WER Stabilizers down			*5500	*5500	*8750	*8750	*8350	*8350	*6900	*6900	*5750	*5750	*4700	*4700	*3700	*3700			*3000	*3000	

BOOM — 30'6" STICK — 22'11" COUNTERWEIGHT — 16,976 lb

English Units/all weights are in lbs

Radius of lift point (center line of the bucket pivot mounting pin) from Swing bearing (ft)

Lift Height	Undercarriage configuration	10.0 ft		15.0 ft		20.0 ft		25.0 ft		30.0 ft		35.0 ft		40.0 ft		45.0 ft		50.0 ft		ft		
		WER up	WER down	WER up	WER down	WER up	WER down	WER up	WER down	WER up	WER down	WER up	WER down	WER up	WER down	WER up	WER down	WER up	WER down			
50.0 ft	WER Stabilizers up					*14,700	*14,700	*12,200	*12,200											*9700	*9700	28.48
	WER Stabilizers down					*14,700	*14,700	*12,200	*12,200											*9700	*9700	
40.0 ft	WER Stabilizers up							*16,300	16,100	13,900	11,600	10,500	8600							8200	6600	39.44
	WER Stabilizers down							*16,300	*16,300	*14,600	*14,600	*12,000								*8200	*8200	
30.0 ft	WER Stabilizers up							*17,500	15,600	13,600	11,300	10,300	8500	8000	6500	6200	4900			6000	4700	45.80
	WER Stabilizers down							*17,500	*17,500	*15,500	*15,500	*13,800	*13,800	*12,500	*12,500	*8800	*8800			*7800	*7800	
20.0 ft	WER Stabilizers up			*27,000	*27,000	*23,400	20,200	17,000	14,000	12,500	10,300	9600	7800	7500	6000	6000	4700			4900	3700	49.34
	WER Stabilizers down			*27,000	*27,000	*23,400	*23,400	*19,400	*19,400	*16,800	*16,800	*14,400	*14,400	*12,700	*12,700	*11,300	11,200			*7900	*7900	
10.0 ft	WER Stabilizers up			30,900	24,200	20,200	16,100	14,500	11,700	11,000	8800	8600	6800	6900	5400	5600	4300	4500	3400	4400	3300	50.69
	WER Stabilizers down			*37,600	*37,600	*27,300	*27,300	*21,500	*21,500	*17,700	*17,700	*15,000	*15,000	*12,900	*12,900	*11,100	10,800	*9400	9000	*8400	*8400	
0.0 ft	WER Stabilizers up	*5000	*5000	*11,000	*11,000	17,000	13,100	12,500	9700	7500	7700	6000	6300	4800	5200	3900	4300	3200	4300	3200	3200	50.03
	WER Stabilizers down	*5000	*5000	*11,000	*11,000	*25,400	*25,400	*21,500	*21,500	*17,500	*17,500	*14,600	*14,600	*12,300	*12,300	*10,200	*10,200	*8100	*8100	*8000	*8000	
-10.0 ft	WER Stabilizers up			*12,400	*12,400	16,100	12,200	11,700	8900	9000	6900	7300	5500	6000	4500	5000	3700			4700	3500	47.28
	WER Stabilizers down			*12,400	*12,400	*20,000	*20,000	*18,000	*18,000	*14,900	*14,900	*12,400	*12,400	*10,100	*10,100	*7800	*7800			*6600	*6600	

*Indicates that the load is limited by hydraulic lifting capacity rather than tipping load.

Oscillating axle needs to be locked. Weight of all lifting accessories must be subtracted from the lifting capacities. All lift capacities calculated and rated per ISO 10567:2007. Rated loads do not exceed 87% of hydraulic lift capacity or 75% of tipping load. Lifting capacities are based on the machine standing on a firm uniform supporting surface. The load point is the center line of the bucket pivot mounting pin on the stick. The use of a work tool attachment point to handle/lift objects, could affect the machine lift performance.

All lifts with heavy lift on. Always refer to the appropriate Operation and Maintenance Manual for specific product information.

MH3022 Specifications

Model	MH3022	
Operating Weight	22 500-24 500 kg	49,604-54,013 lb
Rated Power (ISO 14396)	129 kW	173 hp
Engine Model	C7.1 ACERT™	
Emissions	U.S. EPA Tier 4 Final, EU Stage IV, Japan 2014 (Tier 4 Final)	
Maximum Travel Speed	25 km/h	15.5 mph
Fuel Tank Refill Capacity	330 L	87.2 U.S. gal
Eye Level Height (Cab Fully Raised)	4850 mm	15'11"
Tail Swing Radius	2570 mm	8'5"

MH3022 Range Diagram

- Standard MH Boom — 6400 mm (21'0") and MH Drop Nose Stick — 4900 mm (16'1")

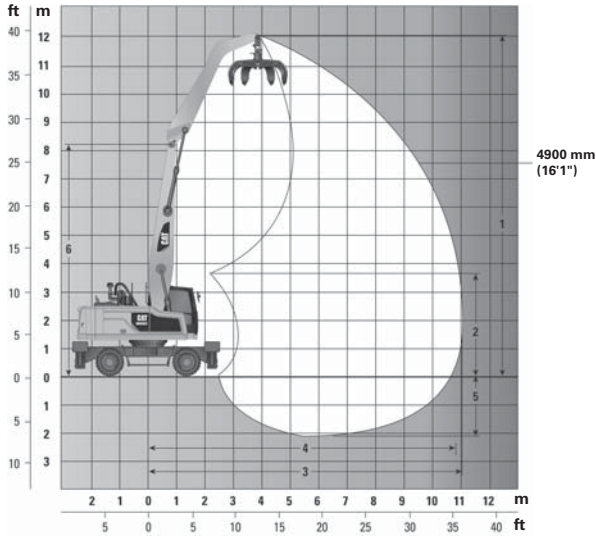

MH3022 Range Diagram

- Standard MH Boom — 6400 mm (21'0") and MH Straight Stick — 4200 mm (13'9")

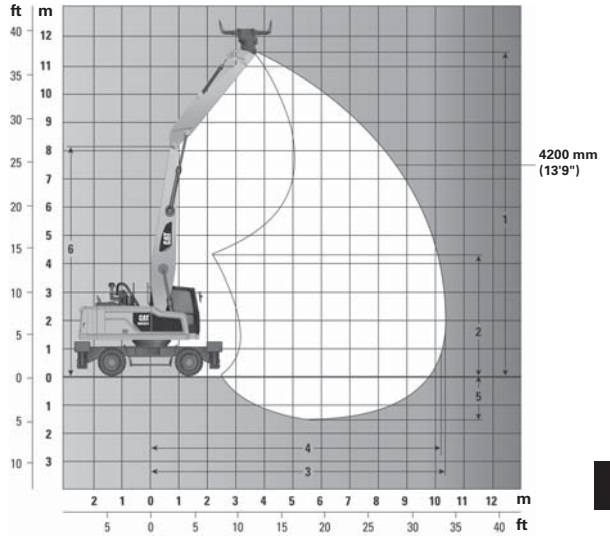

Undercarriage

Special Application MH Undercarriage

Wheel Base	2750 mm (9'0")			
Width over Tires (10.00-20 Solid)	2700 mm (8'10")			
Boom — Boom Length	Standard MH Boom — 6400 mm (21'0")			
Stick — Stick Length	MH Drop Nose Stick — 4900 mm (16'1")		MH Straight Stick — 4200 mm (13'9")	
1 Maximum Vertical Pin Height	12 100 mm	39'8"	11 500 mm	37'9"
2 Minimum Dump Height	3550 mm	11'8"	4200 mm	13'9"
3 Maximum Horizontal Reach	11 000 mm	36'1"	10 300 mm	33'10"
4 Maximum Reach at Ground Level	10 500 mm	34'5"	9800 mm	32'2"
5 Maximum Depth	1920 mm	6'3"	1825 mm	5'11"
6 Boom Pin Height	8235 mm	27'0"	8235 mm	27'0"

MH3022 Range Diagram

- Short MH Boom — 5350 mm (17'7") and MH Drop Nose Stick — 4900 mm (16'1")

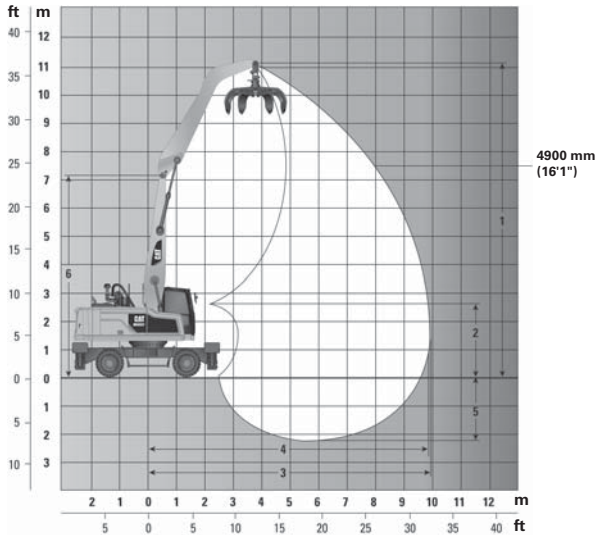

MH3022 Range Diagram

- Short MH Boom — 5350 mm (17'7") and MH Straight Stick — 4200 mm (13'9")

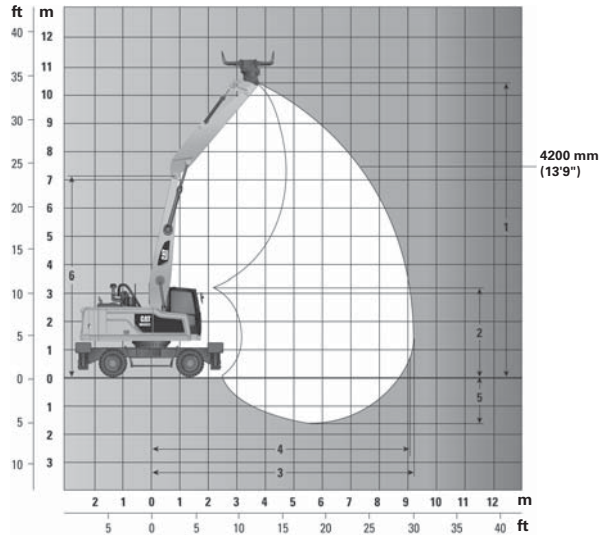

Undercarriage

Compact MH Undercarriage

Wheel Base	2600 mm (8'6")			
Width over Tires (10.00-20 Solid)	2520 mm (8'3")			
Boom — Boom Length	Short MH Boom — 5350 mm (17'7")			
Stick — Stick Length	MH Drop Nose Stick — 4900 mm (16'1")		MH Straight Stick — 4200 mm (13'9")	
1 Maximum Vertical Pin Height	11 020 mm	36'2"	10 440 mm	34'3"
2 Minimum Dump Height	2635 mm	8'8"	3255 mm	10'8"
3 Maximum Horizontal Reach	10 998 mm	36'1"	9330 mm	30'7"
4 Maximum Reach at Ground Level	9600 mm	31'6"	8900 mm	29'2"
5 Maximum Depth	2324 mm	7'7"	1650 mm	5'5"
6 Boom Pin Height	7190 mm	23'7"	7158 mm	23'6"

Lift Capacities

All values are in kg, without bucket, with counterweight (4200 kg), heavy lift on.



Undercarriage

MH (2.75 m) or MH Narrow (2.55 m)

Boom

6.4 m MH

Stick

4.9 m MH

Stick height	Undercarriage configuration	3000 mm			4500 mm			6000 mm			7500 mm			9000 mm			10 500 mm			mm		
		Load point height	Load over front	Load over rear	Load over front	Load over rear	Load over side	Load point height	Load over front	Load over rear	Load over front	Load over rear	Load over side	Load point height	Load over front	Load over rear	Load over front	Load over rear	Load over side			
10 500 mm	SA – 2 sets stabilizers up							6250	6250	4750										5200	5200	3950
	SA – 2 sets stabilizers down							*6500	*6500	*6500										*5250	*5250	*5250
	Narrow – 2 sets stabilizers up							5650	5650	4250										4750	4750	3550
	Narrow – 2 sets stabilizers down							*6450	*6450	*6450										*5300	*5300	*5300
9000 mm	SA – 2 sets stabilizers up							6350	6350	4850	4450	4450	3400							3700	3700	2800
	SA – 2 sets stabilizers down							*7850	*7850	*7850	*6300	*6300	*6300							*4700	*4700	*4700
	Narrow – 2 sets stabilizers up							5800	5800	4350	4050	4050	3000							3400	3400	2500
	Narrow – 2 sets stabilizers down							*7850	*7850	7600	*6250	*6250	5300							*4700	*4700	4450
7500 mm	SA – 2 sets stabilizers up							6350	6350	4850	4450	4450	3400	3300	3300	2500				3050	3050	2300
	SA – 2 sets stabilizers down							*8200	*8200	*8200	*7100	*7100	6900	*5500	*5500	5100				*4400	*4400	*4400
	Narrow – 2 sets stabilizers up							5800	5800	4350	4050	4050	3050	3000	3000	2200				2750	2750	2050
	Narrow – 2 sets stabilizers down							*8150	*8150	7600	*7100	*7100	5300	5450	5450	3950				*4400	*4400	3650
6000 mm	SA – 2 sets stabilizers up							6250	6250	4750	4400	4400	3350	3300	3300	2500				2700	2700	2000
	SA – 2 sets stabilizers down							*8400	*8400	*8400	*7200	*7200	6800	*6200	*6200	5100				*4300	*4300	4150
	Narrow – 2 sets stabilizers up							5700	5700	4250	4000	4000	3000	3000	3000	2200				2400	2400	1750
	Narrow – 2 sets stabilizers down							*8400	*8400	7500	*7200	*7200	5250	5450	5450	3900				*4300	*4300	3200
4500 mm	SA – 2 sets stabilizers up				9450	9450	7000	6000	6000	4550	4300	4300	3250	3250	3250	2450	2500	1850		2450	2450	1800
	SA – 2 sets stabilizers down				*11 150	*11 150	*11 150	*8900	*8900	*8900	*7350	*7350	6700	6200	6200	5000	4850	4850	3950	*4300	*4300	3850
	Narrow – 2 sets stabilizers up				8550	8550	6250	5450	5450	4050	3900	3900	2850	2900	2900	2150	2250	1650		2200	2200	1600
	Narrow – 2 sets stabilizers down				*11 150	*11 150	*11 150	*8850	*8850	7250	7150	7150	5100	5350	5350	3850	4200	3000		4100	4100	2950
3000 mm	SA – 2 sets stabilizers up	17 550	17 550	11 900	8800	8800	6450	5700	5700	4250	4100	4100	3100	3150	3150	2350	2500	1850		2350	2350	1700
	SA – 2 sets stabilizers down	*18 550	*18 550	*18 550	*12 350	*12 350	*12 350	*9350	*9350	9250	*7550	*7550	6500	6050	6050	4950	4800	3900		*4400	*4400	3650
	Narrow – 2 sets stabilizers up	15 550	15 550	10 400	7950	7950	5700	5150	5150	3750	3700	3700	2700	2850	2850	2050	2250	1600		2100	2100	1500
	Narrow – 2 sets stabilizers down	*18 500	*18 500	*18 500	*12 350	*12 350	11 000	*9350	*9350	6950	7000	7000	4950	5250	5250	3750	4150	3000		3900	3900	2800
1500 mm	SA – 2 sets stabilizers up				8150	8150	5850	5400	5400	3950	3950	3950	2900	3050	3050	2250	2450	1800		2300	2300	1650
	SA – 2 sets stabilizers down				*13 000	*13 000	*13 000	*9550	*9550	8850	*7500	*7500	6300	5950	5950	4800	*4700	4800		*4100	*4100	3600
	Narrow – 2 sets stabilizers up				7300	7300	5100	4850	4850	3500	3550	3550	2550	2750	2750	1950	2200	1550		2050	2050	1450
	Narrow – 2 sets stabilizers down				*13 000	*13 000	10 250	*9550	*9550	6600	6800	6800	4750	5150	5150	3650	4100	2950		3850	3850	2750
0 mm	SA – 2 sets stabilizers up	*3500	*3500	*3500	7700	7700	5400	5150	5150	3700	3800	3800	2800	2950	2950	2150	2400	1750				
	SA – 2 sets stabilizers down	*3500	*3500	*3500	*12 200	*12 200	*12 200	*9150	*9150	8600	*7150	*7150	6150	*5550	*5550	4750	*4050	*4050		3800		
	Narrow – 2 sets stabilizers up	*3500	*3500	*3500	6850	6850	4700	4600	4600	3250	3400	3400	2400	2650	2650	1900	2150	1500		1500		
	Narrow – 2 sets stabilizers down	*3500	*3500	*3500	*12 350	*12 350	9750	*9200	*9200	6300	6600	6600	4600	5050	5050	3600	*4050	*4050		2900		
-1500 mm	SA – 2 sets stabilizers up				7450	7450	5200	5000	5000	3600	3700	3700	2700	2900	2900	2100						
	SA – 2 sets stabilizers down				*9600	*9600	*9600	*8000	*8000	*8000	*6200	*6200	6050	*4650	*4650							
	Narrow – 2 sets stabilizers up				6650	6650	4500	4450	4450	3100	3300	3300	2350	2600	2600	1850						
	Narrow – 2 sets stabilizers down				*9600	*9600	9500	*8000	*8000	6150	*6250	*6250	4500	*4700	*4700	3550						

* Limited by hydraulic rather than tipping load.

Lift capacity ratings are based on ISO 10567:2007, they do not exceed 87% of hydraulic lifting capacity or 75% of tipping load. The load point is the center line of the bucket pivot mounting pin on the stick. The oscillating axle must be locked. Lifting capacities are based on the machine standing on a firm uniform supporting surface. For lifting capacity including bucket and/or quick coupler, the respective weight has to be subtracted from above values. The use of a work tool attachment point to handle/lift objects, could affect the machine lift performance.

Always refer to the appropriate Operation and Maintenance Manual for specific product information.

Lift Capacities

All values are in lb, without bucket, with counterweight (9260 lb), heavy lift on.

 Load point height
  Load over front
  Load over rear
  Load over side
  Load at maximum reach (sticknose/bucket pin)

Undercarriage

MH (9'0") or MH Narrow (8'4")

Boom

21'0" MH

Stick

16'1" MH

Stick ft	Undercarriage configuration	10 ft			15 ft			20 ft			25 ft			30 ft			35 ft			ft		
		Load point height	Load over front	Load over rear	Load point height	Load over front	Load over rear	Load point height	Load over front	Load over rear	Load point height	Load over front	Load over rear	Load point height	Load over front	Load over rear	Load point height	Load over front	Load over rear			
35 ft	SA – 2 sets stabilizers up							13,100	13,100	10,000										*11,800	*11,800	9000
	SA – 2 sets stabilizers down							*13,400	*13,400	*13,400										*11,800	*11,800	*11,800
	Narrow – 2 sets stabilizers up							11,900	11,900	8900										10,900	10,900	8100
	Narrow – 2 sets stabilizers down							*13,300	*13,300	*13,300										*11,800	*11,800	*11,800
30 ft	SA – 2 sets stabilizers up							13,500	13,500	10,300	9400	9400	7100							8300	8300	6200
	SA – 2 sets stabilizers down							*16,900	*16,900	*16,900	*13,000	*13,000	*13,000							*10,300	*10,300	*10,300
	Narrow – 2 sets stabilizers up							12,300	12,300	9200	8500	8500	6300							7500	7500	5600
	Narrow – 2 sets stabilizers down							*16,900	*16,900	16,100	*12,900	*12,900	11,100							*10,400	*10,400	9900
25 ft	SA – 2 sets stabilizers up							13,500	13,500	10,300	9400	9400	7200	7000	7000	5200				6700	6700	5000
	SA – 2 sets stabilizers down							*17,800	*17,800	*17,800	*15,400	*15,400	14,600	*11,000	*11,000	10,800				*9700	*9700	*9700
	Narrow – 2 sets stabilizers up							12,300	12,300	9200	8600	8600	6400	6300	6300	4600				6100	6100	4400
	Narrow – 2 sets stabilizers down							*17,800	*17,800	16,200	*15,400	*15,400	11,200	*10,900	*10,900	8300				*9700	*9700	8000
20 ft	SA – 2 sets stabilizers up							13,200	13,200	10,100	9300	9300	7100	6900	6900	5200				5800	5800	4300
	SA – 2 sets stabilizers down							*18,300	*18,300	*18,300	*15,600	*15,600	14,500	13,200	13,200	10,800				*9400	*9400	9100
	Narrow – 2 sets stabilizers up							12,100	12,100	9000	8500	8500	6300	6300	6300	4600				5200	5200	3800
	Narrow – 2 sets stabilizers down							*18,300	*18,300	15,900	15,500	15,500	11,100	11,500	11,500	8300				*9400	*9400	7000
15 ft	SA – 2 sets stabilizers up				20,100	20,100	14,900	12,800	12,800	9600	9100	9100	6800	6800	6800	5100				5300	5300	3900
	SA – 2 sets stabilizers down				*24,200	*24,200	*24,200	*19,200	*19,200	*19,200	*15,900	*15,900	14,200	13,100	13,100	10,700				*9400	*9400	8400
	Narrow – 2 sets stabilizers up				18,200	18,200	13,300	11,600	11,600	8600	8200	8200	6100	6200	6200	4500				4800	4800	3400
	Narrow – 2 sets stabilizers down				*24,100	*24,100	*24,100	*19,200	*19,200	15,400	15,200	15,200	10,800	11,400	11,400	8200				8900	8900	6400
10 ft	SA – 2 sets stabilizers up	37,200	37,200	25,400	18,700	18,700	13,700	12,100	12,100	9000	8700	8700	6500	6600	6600	4900	5200	5200	3800	5000	5000	3700
	SA – 2 sets stabilizers down	*40,000	*40,000	*40,000	*26,700	*26,700	*26,700	*20,200	*20,200	19,600	*16,300	*16,300	13,800	12,900	12,900	10,500	10,200	10,200	8300	*9700	*9700	8000
	Narrow – 2 sets stabilizers up	33,000	33,000	22,200	16,900	16,900	12,100	11,000	11,000	8000	7900	7900	5700	6000	6000	4300	4700	4700	3300	4500	4500	3200
	Narrow – 2 sets stabilizers down	*39,900	*39,900	*39,900	*26,700	*26,700	23,400	*20,200	*20,200	14,700	14,800	14,800	10,500	11,200	11,200	8000	8800	8800	6300	8500	8500	6000
5 ft	SA – 2 sets stabilizers up				17,300	17,300	12,400	11,400	11,400	8400	8300	8300	6100	6400	6400	4700	5100	5100	3700	4900	4900	3600
	SA – 2 sets stabilizers down				*28,100	*28,100	*28,100	*20,700	*20,700	18,800	*16,200	*16,200	13,400	12,700	12,700	10,200	*9900	*9900	8200	*9000	*9000	7800
	Narrow – 2 sets stabilizers up				15,500	15,500	10,800	10,300	10,300	7400	7500	7500	5400	5800	5800	4100	4600	4600	3200	4400	4400	3100
	Narrow – 2 sets stabilizers down				*28,100	*28,100	21,800	20,500	20,500	14,000	14,400	14,400	10,100	10,900	10,900	7800	8700	8700	6200	8300	8300	5900
0 ft	SA – 2 sets stabilizers up	*8000	*8000	*8000	16,300	16,300	11,500	10,900	10,900	7900	8000	8000	5900	6300	6300	4600						
	SA – 2 sets stabilizers down	*8000	*8000	*8000	*26,700	*26,700	*26,700	*19,900	*19,900	18,200	*15,400	*15,400	13,000	*11,900	*11,900	10,000						
	Narrow – 2 sets stabilizers up	*8000	*8000	*8000	14,500	14,500	9900	9700	9700	6800	7200	7200	5100	5600	5600	3900						
	Narrow – 2 sets stabilizers down	*8000	*8000	*8000	*26,700	*26,700	20,700	19,800	19,800	13,400	14,100	14,100	9800	10,800	10,800	7600						
-5 ft	SA – 2 sets stabilizers up				15,800	15,800	11,000	10,600	10,600	7600	7800	7800	5700									
	SA – 2 sets stabilizers down				*22,100	*22,100	*22,100	*17,200	*17,200	*17,200	*13,300	*13,300	12,800									
	Narrow – 2 sets stabilizers up				14,000	14,000	9500	9400	9400	6500	7000	7000	4900									
	Narrow – 2 sets stabilizers down				*22,200	*22,200	20,100	*17,300	*17,300	13,100	*13,400	*13,400	9600									

*Limited by hydraulic rather than tipping load.

Lift capacity ratings are based on ISO 10567:2007, they do not exceed 87% of hydraulic lifting capacity or 75% of tipping load. The load point is the center line of the bucket pivot mounting pin on the stick. The oscillating axle must be locked. Lifting capacities are based on the machine standing on a firm uniform supporting surface. For lifting capacity including bucket and/or quick coupler, the respective weight has to be subtracted from above values. The use of a work tool attachment point to handle/lift objects, could affect the machine lift performance.

Always refer to the appropriate Operation and Maintenance Manual for specific product information.

Lift Capacities

All values are in kg, without bucket, with counterweight (4200 kg), heavy lift on.



Undercarriage

Boom
6.4 m MH

Stick
4.9 m MH

Standard	Undercarriage configuration	3000 mm			4500 mm			6000 mm			7500 mm			9000 mm			10 500 mm			mm			
		Load point height	Load over front	Load over rear	Load over front	Load over rear	Load over side	Load over front	Load over rear	Load over side	Load over front	Load over rear	Load over side	Load over front	Load over rear	Load over side	Load over front	Load over rear	Load over side				
10 500 mm	Front stabilizer and rear dozer up							6100		4550									5050	3750	6700		
	Front stabilizer and rear dozer down							*6500	*6500	*6500									*5250	*5250			
	2 sets stabilizers up							6250		4600									5200	3800			
	2 sets stabilizers down							*6500		*6500									*5250	*5250			
	Front dozer and rear stabilizer up							6300		4550									5250	3750			
9000 mm	Front dozer and rear stabilizer down							*6500	*6500										*5250	*5250	8320		
Front stabilizer and rear dozer up							6250		4650	4350		3250						3600	2700				
Front stabilizer and rear dozer down							*7850	*7850	*7850	*6300	*6300	*6300	4950					*4700	*4700				
2 sets stabilizers up							6400		4700	4450		3250						3700	2700				
2 sets stabilizers down							*7850	*7850	*7850	*6300	*6300	5800						*4700	*4700				
7500 mm	Front dozer and rear stabilizer up						6450		4650	4500		3250						3750	2700	9420			
Front dozer and rear stabilizer down							*7850	*7850	*7850	*6300	*6300	5050						*4700	*4700				
Front stabilizer and rear dozer up							6250		4650	4350		3250	3200		2400			2950	2200				
Front stabilizer and rear dozer down							*8200	*8200	*8200	*7100	*7100	*7100	4950	*5500	*5500	3700			*4400		*4400		
2 sets stabilizers up							6400		4700	4450		3300	3300		2400			3050	3400				
6000 mm	2 sets stabilizers down						*8200	*8200	*8200	*7100	*7100	5850	*5500		4300			*4400	4000	10 180			
Front dozer and rear stabilizer up							6450		4650	4500		3250	3300		2400			3050	2200				
Front dozer and rear stabilizer down							*8200	*8200	*8200	*7100	6950	5050	*5500	5150	3750			*4400	*4400				
Front stabilizer and rear dozer up							6100		4550	4300		3200	3200		2350			2600	1900				
Front stabilizer and rear dozer down							*8400	*8400	*8400	*7200	*7200	*7200	4900	5900	5800	3650			*4300		3000		
4500 mm	2 sets stabilizers up						6300		4600	4400		3250	3300		2400			2650	1900	10 680			
2 sets stabilizers down							*8400	*8400	*8400	*7200	*7200	5750	6050		4300			*4300	3500				
Front dozer and rear stabilizer up							6300		4550	4450		3200	3300		2350			2700	1900				
Front dozer and rear stabilizer down							*8400	*8400	*8400	*7150	*7200	6900	5000	*6200	5100	3750			*4300		4200		
Front stabilizer and rear dozer up							9350		6750	5900		4350	4150		3100	3150		2300	2450				
3000 mm	Front stabilizer and rear dozer down						*11 150	*11 150	10 800	*8900	*8900	6750	*7350	*7350	4800	5800	5750	3600	4550	4500	10 940		
2 sets stabilizers up							9600		6800	6050		4400	4300		3100	3250		2350	2500				
2 sets stabilizers down							*11 150	*11 150	*8900		8050	*7350		5650	6000		4250	4700					
Front dozer and rear stabilizer up							9650		6750	6100		4350	4300		3100	3250		2300	2550				
Front dozer and rear stabilizer down							*11 150	*11 150	11 100	*8900	*8900	6900	*7350	6750	4850	*6200	5050	3650	*4950	3950			
1500 mm	Front stabilizer and rear dozer up	17 750		11 400	8700		6150	5600		4050	4000		2950	3050		2200	2400		1750	2250	11 000		
Front stabilizer and rear dozer down	*18 550	*18 550	*18 550	*12 350	*12 350	10 100	*9350	*9350	6450	*7550	7500	4600	5700	5650	3500	4500	4450	2800	4200	4200			
2 sets stabilizers up	18 200		11 550	8950		6200	5750		4100	4100		2950	3150		2250	2500		1750	2300				
2 sets stabilizers down	*18 550		*18 550	*12 350		*12 350	*9350		7700	*7550		5450	5900		4150	4650		3300	4350				
Front dozer and rear stabilizer up	18 300		11 400	9000		6150	5800		4050	4150		2950	3150		2200	2500		1750	2350				
0 mm	Front dozer and rear stabilizer down	*18 550	*18 550	*18 550	*12 350	*12 350	10 400	*9350	*9350	6600	*7550	6550	4700	*6200	4950	3600	*5000	3900	2850	*4400	3650		
1500 mm	Front stabilizer and rear dozer up						8000	5550	5250		3750	3850		2750	2950		2150	2350		1700	2200	11 000	
Front stabilizer and rear dozer down							*13 000	*13 000	9400	*9550	*9550	6100	7450	7300	4450	5600	5550	3400	4450	4400	2750		*4100
2 sets stabilizers up							8250	5600	5400		3800	3950		2800	3050		2150	2450		1700	2250		
2 sets stabilizers down							*13 000	11 600	*9550		7350	*7500		5250	5750		4050	4600		3250	*4100		
Front dozer and rear stabilizer up							8300	5550	5450		3750	3950		2750	3050		2150	2450		1700	2300		
1500 mm	Front dozer and rear stabilizer down						*13 000	*13 000	9700	*9550	9000	6250	*7500	6350	4550	*6050	4850	3500	*4700	3850	2800	*4100	
0 mm	Front stabilizer and rear dozer up	*3500		*3500	7550		5150	5000		3550	3700		2650	2850		2050	2300		1650	1650	11 000		
Front stabilizer and rear dozer down	*3500	*3500	*3500	*12 200	*12 200	8900	*9150	5850	*7150	7100	4300	5500	5450	3350	*2400			*4050	2700			1700	
2 sets stabilizers up	*3500		*3500	7800		5200	5150		3550	3800		2650	2950		2100	2400		1650	1650				
2 sets stabilizers down	*3500		*3500	*12 200		11 100	*9150	7050	*7150		5100	*5550		3950	*4050			*4050	3200			1700	
Front dozer and rear stabilizer up	*3500		*3500	7850		5150	5200		3550	3850		2650	3000		2050	2400		1650	1650				
0 mm	Front dozer and rear stabilizer down	*3500	*3500	*3500	*12 200	*12 200	9200	*9150	8700	6000	*7150	6200	4400	*5550	4750	3400	*4050	3850	2750		1700		
-1500 mm	Front stabilizer and rear dozer up						7350	4950	4850		3400	3600		2550	2800		2000	2300		1650	1650	11 000	
Front stabilizer and rear dozer down							*9600	*9600	*8000	*8000	5700	6200	*6200	*4650	3000			*4650	3000		1700		
2 sets stabilizers up							7550	5000	5000		3450	3700		2550	2900		2050	2050		1650	1650		
2 sets stabilizers down							*9600	*9600	*8000		6900	6200		5000	*4650		3900	3900		1650	1650		
Front dozer and rear stabilizer up							7600	4950	5050		3400	3750		2550	2950		2000	2000		1650	1650		
-1500 mm	Front dozer and rear stabilizer down						*9600	*9600	8950	*8000	*8000	5850	*6200	6100	4300	*4650	*4650	3350				1700	

*Limited by hydraulic rather than tipping load.

Lift capacity ratings are based on ISO 10567:2007, they do not exceed 87% of hydraulic lifting capacity or 75% of tipping load. The load point is the center line of the bucket pivot mounting pin on the stick. The oscillating axle must be locked. Lifting capacities are based on the machine standing on a firm uniform supporting surface. For lifting capacity including bucket and/or quick coupler, the respective weight has to be subtracted from above values. The use of a work tool attachment point to handle/lift objects, could affect the machine lift performance.

Always refer to the appropriate Operation and Maintenance Manual for specific product information.

Lift Capacities

All values are in lb, without bucket, with counterweight (9260 lb), heavy lift on.



Undercarriage

Boom

Stick

Standard

21'0" MH

16'1" MH

Stick	Undercarriage configuration	10 ft			15 ft			20 ft			25 ft			30 ft			35 ft			ft			
		Load point height	Load over front	Load over rear	Load over front	Load over rear	Load over side	Load over front	Load over rear	Load over side	Load over front	Load over rear	Load over side	Load over front	Load over rear	Load over side	Load over front	Load over rear	Load over side				
35 ft	Front stabilizer and rear dozer up							12,900	12,200	9,900										11,600	11,100	8,600	
	Front stabilizer and rear dozer down							*13,400	*13,400	*13,400										*11,800	*11,800	*11,800	
	2 sets stabilizers up							13,200	12,200	9,600										*11,800	11,000	8,700	
	2 sets stabilizers down							*13,400	*13,400	*13,400										*11,800	*11,800	*11,800	
	Front dozer and rear stabilizers up							13,300	11,800	9,900										*11,800	10,700	8,600	
	Front dozer and rear stabilizers down							*13,400	*13,400	*13,400										*11,800	*11,800	*11,800	
30 ft	Front stabilizer and rear dozer up							13,200	12,600	9,900	9,100	8,700	6,800							8,000	7,700	5,900	
	Front stabilizer and rear dozer down							*16,900	*16,900	14,700	*13,000	*13,000	*13,000	10,200						*10,300	*10,300	9,000	
	2 sets stabilizers up							13,600	12,500	10,000	9,400	8,700	6,900							8,300	7,600	6,000	
	2 sets stabilizers down							*16,900	*16,900	*16,900	*13,000	*13,000	*13,000	12,300						*10,300	*10,300	*10,300	
	Front dozer and rear stabilizers up							13,600	12,200	9,900	9,400	8,400	6,800							8,300	7,400	5,900	
	Front dozer and rear stabilizers down							*16,900	*16,900	15,100	*13,000	*13,000	10,400							*10,300	*10,300	9,200	
25 ft	Front stabilizer and rear dozer up							13,200	12,600	9,900	9,200	8,800	6,900	6,700	6,500	5,000				6,500	6,200	4,700	
	Front stabilizer and rear dozer down							*17,800	*17,800	14,700	*15,400	*15,400	10,200	*11,000	*11,000	7,500				*9,700	*9,700	7,300	
	2 sets stabilizers up							13,600	12,500	10,000	9,500	8,800	6,900	6,900	6,400	5,000				6,700	6,200	4,800	
	2 sets stabilizers down							*17,800	*17,800	*17,800	*15,400	*15,400	15,200	12,400	*11,000	*11,000	9,100				*9,700	*9,700	8,800
	Front dozer and rear stabilizers up							13,600	12,200	9,900	9,500	8,500	6,900	7,000	6,200	5,000				6,700	6,000	4,700	
	Front dozer and rear stabilizers down							*17,800	*17,800	15,100	*15,400	14,700	10,500	*11,000	10,800	7,700				*9,700	*9,700	7,400	
20 ft	Front stabilizer and rear dozer up							13,000	12,300	9,600	9,100	8,700	6,700	6,700	6,500	4,900				5,600	5,400	4,100	
	Front stabilizer and rear dozer down							*18,300	*18,300	14,500	*15,600	*15,600	10,100	12,500	12,300	7,500				*9,400	*9,400	6,300	
	2 sets stabilizers up							13,300	12,300	9,700	9,300	8,600	6,800	6,900	6,400	5,000				5,800	5,400	4,100	
	2 sets stabilizers down							*18,300	*18,300	17,600	*15,600	15,000	12,200	12,800	11,200	9,100				*9,400	9,000	7,700	
	Front dozer and rear stabilizers up							13,400	11,900	9,600	9,400	8,400	6,700	7,000	6,200	4,900				5,800	5,200	4,100	
	Front dozer and rear stabilizers down							*18,300	*18,300	14,800	*15,600	14,600	10,400	*13,400	10,800	7,700				*9,400	9,100	6,500	
15 ft	Front stabilizer and rear dozer up							19,900	18,600	14,300	12,500	11,900	9,200	8,800	8,400	6,500	6,600	6,300	4,800	5,100	4,900	3,700	
	Front stabilizer and rear dozer down							*24,200	*24,200	22,300	*19,200	*19,200	14,000	*15,900	9,900	12,300	12,200	7,400		*9,400	*9,400	5,800	
	2 sets stabilizers up							20,400	18,500	14,500	12,800	11,800	9,300	9,100	8,400	6,600	6,800	6,300	4,900	5,300	4,900	3,700	
	2 sets stabilizers down							*24,200	*24,200	*24,200	*19,200	*19,200	17,000	*15,900	14,700	11,900	12,700	11,000	9,000	*9,400	8,600	7,000	
	Front dozer and rear stabilizers up							20,500	18,000	14,300	12,900	11,500	9,200	9,100	8,100	6,500	6,900	6,100	4,800	5,300	4,700	3,700	
	Front dozer and rear stabilizers down							*24,200	*24,200	23,000	*19,200	*19,200	14,300	*15,900	14,300	10,100	*13,400	10,700	7,600	*9,400	8,400	5,900	
10 ft	Front stabilizer and rear dozer up	37,600	33,700	24,300	18,500	17,300	13,100	11,800	11,200	8,600	8,100	6,200	6,400	6,100	4,700	5,000	4,800	3,600	4,800	4,600	3,400		
	Front stabilizer and rear dozer down	*40,000	*40,000	*40,000	*26,700	*26,700	20,800	*20,200	*20,200	13,300	16,200	15,900	9,500	12,100	12,000	7,200	9,500	9,400	5,700	9,200	9,100	5,500	
	2 sets stabilizers up	38,600	33,600	24,500	19,000	17,200	13,200	12,200	11,200	8,700	8,700	8,000	6,200	6,600	6,100	4,700	5,200	4,800	3,700	5,000	4,600	3,500	
	2 sets stabilizers down	*40,000	*40,000	*40,000	*26,700	*26,700	26,300	*20,200	*20,200	16,300	*16,300	14,300	11,600	12,500	10,800	8,800	9,800	8,600	6,900	9,400	8,200	6,700	
	Front dozer and rear stabilizers up	38,800	32,600	24,300	19,100	16,700	13,100	12,300	10,800	8,600	8,800	7,800	6,200	6,700	5,900	4,700	5,200	4,600	3,600	5,000	4,400	3,400	
	Front dozer and rear stabilizers down	*40,000	*40,000	*40,000	*26,700	*26,700	21,600	*20,200	19,900	13,700	*16,300	13,900	9,700	*13,400	10,500	7,400	*10,700	8,300	5,800	*9,700	8,000	5,600	
5 ft	Front stabilizer and rear dozer up							17,000	15,900	11,800	11,100	10,600	8,000	8,100	7,700	5,800	6,200	5,900	4,500	4,900	4,700	3,500	
	Front stabilizer and rear dozer down							*28,100	*28,100	19,300	*20,700	*20,700	12,600	15,800	15,500	9,100	11,900	11,700	7,000	9,400	9,300	5,600	
	2 sets stabilizers up							17,500	15,800	11,900	11,500	10,500	8,100	8,300	7,700	5,900	6,400	5,900	4,500	5,100	4,700	3,600	
	2 sets stabilizers down							*28,100	*28,100	24,600	*20,700	19,700	15,600	*16,200	13,900	11,200	12,200	10,600	8,600	9,700	8,500	6,800	
	Front dozer and rear stabilizers up							17,600	15,300	11,800	11,600	10,200	8,000	8,400	7,400	5,800	6,500	5,700	4,500	5,100	4,500	3,500	
	Front dozer and rear stabilizers down							*28,100	*28,100	20,000	*20,700	19,100	12,900	*16,200	13,500	9,400	*13,000	10,300	7,200	*9,900	8,200	5,700	
0 ft	Front stabilizer and rear dozer up	*8000	*8000	*8000	16,000	14,900	10,900	10,600	10,000	7,400	7,800	7,400	5,500	6,000	5,800	4,300							
	Front stabilizer and rear dozer down	*8000	*8000	*8000	*26,700	*26,700	18,300	*19,800	*19,800	12,000	*15,400	15,100	8,800	11,700	11,500	6,800							
	2 sets stabilizers up	*8000	*8000	*8000	16,500	14,800	11,000	10,900	10,000	7,500	8,000	7,400	5,600	6,200	5,700	4,400							
	2 sets stabilizers down	*8000	*8000	*8000	*26,700	*26,700	23,500	*19,800	19,100	15,000	*15,400	13,600	10,800	*11,900	10,400	8,400							
	Front dozer and rear stabilizers up	*8000	*8000	*8000	16,600	14,300	10,900	11,000	9,600	7,400	8,100	7,100	5,500	6,300	5,500	4,300							
	Front dozer and rear stabilizers down	*8000	*8000	*8000	*26,700	*26,700	18,900	*19,800	18,500	12,400	*15,400	13,200	9,000	*11,900	10,100	7,000							
-5 ft	Front stabilizer and rear dozer up							15,500	14,500	10,400	10,300	9,700	7,100	7,600	7,200	5,300							
	Front stabilizer and rear dozer down							*22,100	*22,100	17,800	*17,200	*17,200	11,700	*13,300	*13,300	8,600							
	2 sets stabilizers up							16,000	14,400	10,600	10,600	9,700	7,200	7,800	7,200	5,400							
	2 sets stabilizers down							*22,100	*22,100	*22,100	*17,200	*17,200	14,600	*13,300	*13,300	10,600							
	Front dozer and rear stabilizers up							16,100	13,900	10,400	10,700	9,300	7,100	7,900	6,900	5,300							
	Front dozer and rear stabilizers down							*22,100	*22,100	18,400	*17,200	*17,200	12,000	*13,300	12,900	8,800							

*Limited by hydraulic rather than tipping load.

Lift capacity ratings are based on ISO 10567:2007, they do not exceed 87% of hydraulic lifting capacity or 75% of tipping load. The load point is the center line of the bucket pivot mounting pin on the stick. The oscillating axle must be locked. Lifting capacities are based on the machine standing on a firm uniform supporting surface. For lifting capacity including bucket and/or quick coupler, the respective weight has to be subtracted from above values. The use of a work tool attachment point to handle/lift objects, could affect the machine lift performance.

Always refer to the appropriate Operation and Maintenance Manual for specific product information.

Lift Capacities

All values are in kg, bucket cylinder and linkage installed, without bucket, with counterweight (4200 kg), heavy lift on.



Undercarriage

MH (2.75 m) or MH Narrow (2.55 m)

Boom
6.4 m MH

Stick

4.2 m Straight Stick

Stick height	Undercarriage configuration	3000 mm			4500 mm			6000 mm			7500 mm			9000 mm			Load at maximum reach (sticknose/bucket pin)					
		Load over front	Load over side	Load over rear	Load over front	Load over side	Load over rear	Load over front	Load over side	Load over rear	Load over front	Load over side	Load over rear	Load over front	Load over side	Load over rear	mm	mm	mm			
9000 mm	SA – 2 sets stabilizers up							5900	5900	4400							4050	4050	3000			
	SA – 2 sets stabilizers down							*8100	*8100	*8100							*5300	*5300	*5300			
	Narrow – 2 sets stabilizers up							5350	5350	3900							3700	3700	2650			
	Narrow – 2 sets stabilizers down							*8050	*8050	7150							*5300	*5300	4950			
7500 mm	SA – 2 sets stabilizers up							5900	5900	4400	4050	4050	3000				3150	3150	2250			
	SA – 2 sets stabilizers down							*8250	*8250	*8250	*7000	*7000	6450				*4900	*4900	*4900			
	Narrow – 2 sets stabilizers up							5350	5350	3950	3650	3650	2650				2800	2800	2000			
	Narrow – 2 sets stabilizers down							*8250	*8250	7150	6950	6950	4900				*4900	*4900	3800			
6000 mm	SA – 2 sets stabilizers up							9350	9350	6900	5800	5800	4300	4000	4000	2950	2900	2900	2100	2650	2650	1900
	SA – 2 sets stabilizers down							*10 600	*10 600	*10 600	*8500	*8500	*8500	*7050	*7050	6400	5850	5850	4700	*4750	*4750	4300
	Narrow – 2 sets stabilizers up							8450	8450	6100	5250	5250	3800	3600	3600	2600	2600	2600	1800	2350	2350	1650
	Narrow – 2 sets stabilizers down							*10 600	*10 600	*10 600	*8450	*8450	7050	6900	6900	4850	5050	5050	3550	4600	4600	3250
4500 mm	SA – 2 sets stabilizers up	*14 500	*14 500	12 500	8850	8850	6450	5550	5550	4100	3900	3900	2850	2850	2850	2050	2350	2350	1650			
	SA – 2 sets stabilizers down	*14 500	*14 500	*14 500	*11 500	*11 500	*11 500	*8850	*8850	*8850	*7150	*7150	6250	5800	5800	4650	*4750	*4750	3900			
	Narrow – 2 sets stabilizers up	*14 250	*14 250	10 950	8000	8000	5700	5000	5000	3600	3500	3500	2500	2550	2550	1750	2100	2100	1400			
	Narrow – 2 sets stabilizers down	*14 250	*14 250	*14 250	*11 500	*11 500	11 100	*8850	*8850	6800	6750	6750	4700	5000	5000	3500	4200	4200	2900			
3000 mm	SA – 2 sets stabilizers up				8200	8200	5850	5250	5250	3800	3700	3700	2700	2800	2800	2000	2200	2200	1550			
	SA – 2 sets stabilizers down				*12 450	*12 450	*12 450	*9200	*9200	8750	*7200	*7200	6100	5700	5700	4550	*4500	*4500	3700			
	Narrow – 2 sets stabilizers up				7350	7350	5100	4700	4700	3350	3350	3350	2350	2450	2450	1700	1950	1950	1300			
	Narrow – 2 sets stabilizers down				*12 400	*12 400	10 350	*9150	*9150	6450	6600	6600	4550	4900	4900	3400	3950	3950	2750			
1500 mm	SA – 2 sets stabilizers up				7550	7550	5300	4950	4950	3550	3550	3550	2550	2700	2700	1900	2150	2150	1500			
	SA – 2 sets stabilizers down				*12 450	*12 450	*12 450	*9100	*9100	8400	*7000	*7000	5900	*5450	*5450	4450	*3950	*3950	3600			
	Narrow – 2 sets stabilizers up				6700	6700	4550	4400	4400	3050	3150	3150	2200	2400	2400	1600	1900	1900	1250			
	Narrow – 2 sets stabilizers down				*12 500	*12 500	9650	*9100	*9100	6150	6400	6400	4400	4800	4800	3300	3900	3900	2650			
0 mm	SA – 2 sets stabilizers up				7200	7200	4950	4750	4750	3350	3450	3450	2400	2650	2650	1850						
	SA – 2 sets stabilizers down				*9400	*9400	*9400	*8350	*8350	8150	*6400	*6400	5800	*4800	*4800	4400						
	Narrow – 2 sets stabilizers up				6350	6350	4250	4200	4200	2850	3050	3050	2050	2350	2350	1550						
	Narrow – 2 sets stabilizers down				*9450	*9450	9250	*8400	*8400	5900	6250	6250	4250	4750	4750	3250						

*Limited by hydraulic rather than tipping load.

Lift capacity ratings are based on ISO 10567:2007, they do not exceed 87% of hydraulic lifting capacity or 75% of tipping load. The load point is the center line of the bucket pivot mounting pin on the stick. The oscillating axle must be locked. Lifting capacities are based on the machine standing on a firm uniform supporting surface. For lifting capacity including bucket and/or quick coupler, the respective weight has to be subtracted from above values. The use of a work tool attachment point to handle/lift objects, could affect the machine lift performance.

Always refer to the appropriate Operation and Maintenance Manual for specific product information.

Lift Capacities

All values are in lb, bucket cylinder and linkage installed, without bucket, with counterweight (9260 lb), heavy lift on.



Undercarriage MH (9'0") or MH Narrow (8'4")		Boom 21'0" MH						Stick 13'9" Straight Stick												
		10 ft		15 ft		20 ft		25 ft			30 ft				Load at maximum reach (sticknose/bucket pin)			ft		
Load point height	Load over front	Load over front	Load over front	Load over rear	Load over rear	Load over rear	Load over side	Load over side	Load over side	Load over side	Load over side	Load over side	Load over side	Load over side	Load over side	Load over side	Load over side		Load over side	Load over side
30 ft	SA – 2 sets stabilizers up						12,500	12,500	9300								9100	9100	6700	23.85
	SA – 2 sets stabilizers down						*17,100	*17,100	*17,100								*11,800	*11,800	*11,800	
	Narrow – 2 sets stabilizers up						11,300	11,300	8300								8300	8300	6000	
	Narrow – 2 sets stabilizers down						*17,100	*17,100	15,100								*11,800	*11,800	11,100	
25 ft	SA – 2 sets stabilizers up						12,600	12,600	9400	8600	8600	6300					6900	6900	5000	28.08
	SA – 2 sets stabilizers down						*18,000	*18,000	*18,000	*15,200	*15,200	13,700					*10,900	*10,900	*10,900	
	Narrow – 2 sets stabilizers up						11,400	11,400	8300	7700	7700	5500					6200	6200	4400	
	Narrow – 2 sets stabilizers down						*18,000	*18,000	15,200	14,800	14,800	10,400					*10,900	*10,900	8400	
20 ft	SA – 2 sets stabilizers up				19,900	19,900	14,700	12,300	12,300	9200	8500	8500	6200	6100	6100	4400	5800	5800	4100	30.91
	SA – 2 sets stabilizers down				*23,000	*23,000	*23,000	*18,400	*18,400	*18,400	*15,300	*15,300	13,600	12,400	12,400	10,000	*10,500	*10,500	9500	
	Narrow – 2 sets stabilizers up				18,000	18,000	13,000	11,100	11,100	8100	7600	7600	5500	5500	5500	3800	5200	5200	3600	
	Narrow – 2 sets stabilizers down				*23,000	*23,000	*23,000	*18,400	*18,400	15,000	14,700	14,700	10,300	10,700	10,700	7500	10,200	10,200	7100	
15 ft	SA – 2 sets stabilizers up	*31,000	*31,000	26,700	18,900	18,900	13,700	11,800	11,800	8700	8200	8200	6000	6100	6100	4300	5200	5200	3600	32.74
	SA – 2 sets stabilizers down	*31,000	*31,000	*31,000	*24,900	*24,900	*24,900	*19,200	*19,200	*19,200	*15,500	*15,500	13,300	12,300	12,300	9900	*10,500	*10,500	8500	
	Narrow – 2 sets stabilizers up	*30,600	*30,600	23,400	17,000	17,000	12,100	10,700	10,700	7700	7400	7400	5200	5400	5400	3700	4600	4600	3100	
	Narrow – 2 sets stabilizers down	*30,600	*30,600	*30,600	*24,900	*24,900	23,600	*19,200	*19,200	14,500	14,400	14,400	10,000	10,600	10,600	7400	9100	9100	6300	
10 ft	SA – 2 sets stabilizers up				17,400	17,400	12,400	11,200	11,200	8100	7900	7900	5700	5900	5900	4200	4800	4800	3400	33.73
	SA – 2 sets stabilizers down				*26,900	*26,900	*26,900	*19,900	*19,900	18,600	*15,600	*15,600	13,000	12,100	12,100	9700	*9900	*9900	8000	
	Narrow – 2 sets stabilizers up				15,600	15,600	10,900	10,000	10,000	7100	7100	7100	4900	5200	5200	3600	4300	4300	2800	
	Narrow – 2 sets stabilizers down				*26,900	*26,900	22,000	*19,900	*19,900	13,800	14,000	14,000	9700	10,400	10,400	7200	8600	8600	5900	
5 ft	SA – 2 sets stabilizers up				16,100	16,100	11,200	10,500	10,500	7500	7600	7600	5400	5700	5700	4000	4700	4700	3200	33.92
	SA – 2 sets stabilizers down				*27,100	*27,100	*27,100	*19,800	*19,800	17,900	*15,200	*15,200	12,600	*11,700	*11,700	9500	*8700	*8700	7900	
	Narrow – 2 sets stabilizers up				14,300	14,300	9700	9400	9400	6500	6700	6700	4600	5100	5100	3400	4100	4100	2700	
	Narrow – 2 sets stabilizers down				*27,100	*27,100	20,500	19,500	19,500	13,100	13,600	13,600	9300	10,200	10,200	7000	8400	8400	5800	
0 ft	SA – 2 sets stabilizers up				15,300	15,300	10,500	10,100	10,100	7100	7300	7300	5100	5600	5600	3900				
	SA – 2 sets stabilizers down				*22,100	*22,100	*22,100	*18,100	*18,100	17,400	*13,800	*13,800	12,300	*10,200	*10,200	9400				
	Narrow – 2 sets stabilizers up				13,500	13,500	9000	8900	8900	6000	6500	6500	4400	4900	4900	3300				
	Narrow – 2 sets stabilizers down				*22,200	*22,200	19,600	*18,200	*18,200	12,600	13,300	13,300	9000	10,100	10,100	6900				

*Limited by hydraulic rather than tipping load.

Lift capacity ratings are based on ISO 10567:2007, they do not exceed 87% of hydraulic lifting capacity or 75% of tipping load. The load point is the center line of the bucket pivot mounting pin on the stick. The oscillating axle must be locked. Lifting capacities are based on the machine standing on a firm uniform supporting surface. For lifting capacity including bucket and/or quick coupler, the respective weight has to be subtracted from above values. The use of a work tool attachment point to handle/lift objects, could affect the machine lift performance.

Always refer to the appropriate Operation and Maintenance Manual for specific product information.

Lift Capacities

All values are in kg, bucket cylinder and linkage installed, without bucket, with counterweight (4200 kg), heavy lift on.

Load point height Load over front Load over rear Load over side Load at maximum reach (sticknose/bucket pin)

Undercarriage

Boom
6.4 m MH

Stick

4.2 m Straight Stick

Standard

	Undercarriage configuration	3000 mm			4500 mm			6000 mm			7500 mm			9000 mm					mm	
9000 mm	Front stabilizer and rear dozer up							5800		4200							3950		2850	7420
	Front stabilizer and rear dozer down							*8100	*8100	6650							*5300	*5300	4550	
	2 sets stabilizers up							5950		4250							4050		2900	
	2 sets stabilizers down							*8100		7950							*5300		*5300	
	Front dozer and rear stabilizer up							6000		4200							4100		2850	
	Front dozer and rear stabilizer down							*8100	*8100	6800							*5300	*5300	4650	
7500 mm	Front stabilizer and rear dozer up							5800		4250	3950		2850				3000		2150	8640
	Front stabilizer and rear dozer down							*8250	*8250	6650	*7000		4550				*4900	*4900	3500	
	2 sets stabilizers up							5950		4250	4050		2900				3100		2200	
	2 sets stabilizers down							*8250	*8250	7950	*7000		5400				*4900		4200	
	Front dozer and rear stabilizer up							6000		4250	4100		2850				3150		2150	
	Front dozer and rear stabilizer down							*8250	*8250	6850	*7000	6550	4650				*4900	*4900	3600	
6000 mm	Front stabilizer and rear dozer up					9250		6600	5650	4100	3900		2800	2800		2000	2550		1800	9460
	Front stabilizer and rear dozer down				*10 600	*10 600	*10 600	*8500	*8500	6550	*7050		4500	5500	5400	3300	*4750	*4750	3000	
	2 sets stabilizers up				9500			6650	5850	4150	4000		2850	2900	2000	2650			1800	
	2 sets stabilizers down				*10 600	*10 600	*10 600	*8500	*8500	7800	*7050		5350	5650	3900	*4750			3600	
	Front dozer and rear stabilizer up				9550			6600	5850	4100	4050		2800	2900	2000	2650			1800	
	Front dozer and rear stabilizer down				*10 600	*10 600	*10 600	*8500	*8500	6700	*7050	6450	4600	*5900	4750	3350	*4750	4300	3050	
4500 mm	Front stabilizer and rear dozer up	*14 500		12 000	8750	6150	5450	3900	3750			2700	2750		1950	2250		1550	10 000	
	Front stabilizer and rear dozer down	*14 500	*14 500	*14 500	*11 500	10 200	*8850	*8850	6300	*7150		4400	5450	5350	3250	4550	4500	2700		
	2 sets stabilizers up	*14 500		12 100	9000	6250	5600	3950	3900			2700	2850		1950	2350		1600		
	2 sets stabilizers down	*14 500		*14 500	*11 500	11 500	*8850	7550	*7150			5250	5600		3850	4700		3250		
	Front dozer and rear stabilizer up	*14 500		12 000	9050	6150	5650	3900	3900			2700	2900		1950	2400		1550		
	Front dozer and rear stabilizer down	*14 500	*14 500	*14 500	*11 500	10 500	*8850	*8850	6450	*7150	6350	4450	*5850	4700	3300	*4750	3900	2750		
3000 mm	Front stabilizer and rear dozer up				8050	5550	5150	3600	3600			2550	2700		1850	2150		1450	10 280	
	Front stabilizer and rear dozer down				*12 450	*12 450	9500	*9200	*9200	6000	*7200	7100	4200	5350	5250	3150	4300	4250		2500
	2 sets stabilizers up				8300			5650	5300	3650	3750		2550	2800		1900	2200	1450		
	2 sets stabilizers down				*12 450		11 700	*9200		7200	*7200		5050	5500		3800	4450			3050
	Front dozer and rear stabilizer up				8350			5550	5300	3600	3750		2550	2800		1850	2250			1450
	Front dozer and rear stabilizer down				*12 450	*12 450	9750	*9200	8900	6150	*7200	6150	4300	*5750	4600	3200	*4500	3700		2600
1500 mm	Front stabilizer and rear dozer up				7450	5000	4800	3350	3450			2400	2600		1800	2050		1400	10 340	
	Front stabilizer and rear dozer down				*12 450	*12 450	8800	*9100	*9100	5650	*7000	6900	4050	5250	5200	3050	*3950	*3950		2450
	2 sets stabilizers up				7650			5050	5000	3400	3550		2400	2700		1800	2150			1400
	2 sets stabilizers down				*12 450		11 000	*9100		6900	*7000		4900	5400		3700	*3950			3000
	Front dozer and rear stabilizer up				7700			5000	5000	3350	3600		2400	2700		1800	2150			1400
	Front dozer and rear stabilizer down				*12 450	*12 450	9100	*9100	8550	5800	*7000	6000	4150	*5450	4500	3150	*3950	3600		2500
0 mm	Front stabilizer and rear dozer up				7050	4650	4600	3150	3300			2250	2550		1700					
	Front stabilizer and rear dozer down				*9400	*9400	8450	*8350	*8350	5450	*6400	*6400	3900	*4800	*4800	3000				
	2 sets stabilizers up				7300			4750	4750	3200	3450		2300	2650		1750				
	2 sets stabilizers down				*9400		*9400	*8350		6650	*6400		4750	*4800		3650				
	Front dozer and rear stabilizer up				7350			4650	4800	3150	3450		2250	2650		1700				
	Front dozer and rear stabilizer down				*9400	*9400	8700	*8350	8300	5600	*6400	5850	4000	*4800	4450	3050				

9

* Limited by hydraulic rather than tipping load.

Lift capacity ratings are based on ISO 10567:2007, they do not exceed 87% of hydraulic lifting capacity or 75% of tipping load. The load point is the center line of the bucket pivot mounting pin on the stick. The oscillating axle must be locked. Lifting capacities are based on the machine standing on a firm uniform supporting surface. For lifting capacity including bucket and/or quick coupler, the respective weight has to be subtracted from above values. The use of a work tool attachment point to handle/lift objects, could affect the machine lift performance.

Always refer to the appropriate Operation and Maintenance Manual for specific product information.

Lift Capacities

All values are in lb, bucket cylinder and linkage installed, without bucket, with counterweight (9260 lb), heavy lift on.

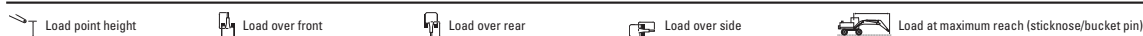

Undercarriage

Boom

Stick

Standard

21'0" MH

13'9" Straight Stick

Stick ft	Undercarriage configuration	10 ft			15 ft			20 ft			25 ft			30 ft			ft				
		Load over front	Load over rear	Load over side	Load over front	Load over rear	Load over side	Load over front	Load over rear	Load over side	Load over front	Load over rear	Load over side	Load over front	Load over rear	Load over side					
30 ft	Front stabilizer and rear dozer up							12,200	11,600	8900							8900	8500	6400	23.85	
	Front stabilizer and rear dozer down							*17,100	*17,100	13,700							*11,800	*11,800	10,000		
	2 sets stabilizers up							12,600	11,500	9000							9200	8400	6500		
	2 sets stabilizers down							*17,100	*17,100	16,800							*11,800	*11,800	*11,800		
	Front dozer and rear stabilizers up							12,700	11,200	8900							9200	8100	6400		
	Front dozer and rear stabilizers down							*17,100	*17,100	14,100							*11,800	*11,800	10,300		
25 ft	Front stabilizer and rear dozer up							12,300	11,700	9000	8300	7900	6000				6700	6400	4700	28.08	
	Front stabilizer and rear dozer down							*18,000	*18,000	13,800	*15,200	*15,200	9400				*10,900	*10,900	7600		
	2 sets stabilizers up							12,600	11,600	9100	8600	7900	6100				6900	6300	4800		
	2 sets stabilizers down							*18,000	*18,000	16,900	*15,200	*15,200	11,500				*10,900	*10,900	9300		
	Front dozer and rear stabilizers up							12,700	11,300	9000	8600	7600	6000				7000	6100	4700		
	Front dozer and rear stabilizers down							*18,000	*18,000	14,200	*15,200	*15,200	9600				*10,900	*10,900	7800		
20 ft	Front stabilizer and rear dozer up				19,700	18,400	14,000	12,100	11,400	8700	8200	7900	5900	5600	4100		5600	5300	3900	30.91	
	Front stabilizer and rear dozer down				*23,000	*23,000	22,100	*18,400	*18,400	13,500	*15,300	*15,300	9300	11,700	11,500	6700	*10,500	*10,500	6400		
	2 sets stabilizers up				20,200	18,300	14,200	12,400	11,400	8800	8500	7800	6000	6100	5600	4200	5800	5300	3900		
	2 sets stabilizers down				*23,000	*23,000	23,000	*18,400	*18,400	16,600	*15,300	*15,300	14,200	11,400	10,300	8300	*10,500	9800	7900		
	Front dozer and rear stabilizers up				20,300	17,800	14,000	12,500	11,000	8700	8600	7500	5900	6200	5400	4100	5800	5100	3900		
	Front dozer and rear stabilizers down				*23,000	*23,000	22,800	*18,400	*18,400	13,900	*15,300	*15,300	13,700	9500	*12,800	10,000	6900	*10,500	9500		6500
15 ft	Front stabilizer and rear dozer up	*31,000	*31,000	25,600	18,600	17,400	13,100	11,600	10,900	8300	8000	7600	5700	5800	5600	4100	5000	4700	3400	32.74	
	Front stabilizer and rear dozer down	*31,000	*31,000	*31,000	*24,900	*24,900	21,000	*19,200	*19,200	13,000	*15,500	*15,500	9000	11,600	11,400	6600	9900	9800	5700		
	2 sets stabilizers up	*31,000	*31,000	25,800	19,100	17,300	13,300	11,900	10,900	8400	8200	7600	5800	6000	5500	4100	5100	4700	3500		
	2 sets stabilizers down	*31,000	*31,000	*31,000	*24,900	*24,900	24,900	*19,200	*19,200	16,100	*15,500	*15,500	13,900	11,100	11,900	10,300	8200	10,200	8800		7000
	Front dozer and rear stabilizers up	*31,000	*31,000	25,600	19,300	16,800	13,100	12,000	10,500	8300	8300	7300	5700	6100	5300	4100	5200	4500	3400		
	Front dozer and rear stabilizers down	*31,000	*31,000	*31,000	*24,900	*24,900	21,700	*19,200	*19,200	13,400	*15,500	*15,500	13,500	9300	*12,700	9900	6800	*10,500	8500		5800
10 ft	Front stabilizer and rear dozer up				17,200	16,000	11,800	10,900	10,300	7700	7700	7300	5400	5700	5400	3900	4600	4400	3100	33.73	
	Front stabilizer and rear dozer down				*26,900	*26,900	19,500	*19,900	*19,900	12,300	15,400	15,100	8700	11,400	11,200	6500	9400	9300	5300		
	2 sets stabilizers up				17,700	15,900	12,000	11,200	10,200	7800	7900	7200	5400	5900	5400	4000	4800	4400	3200		
	2 sets stabilizers down				*26,900	*26,900	24,900	*19,900	*19,900	15,500	*15,600	*15,600	13,500	10,800	11,700	10,100	8000	9700	8300		6600
	Front dozer and rear stabilizers up				17,800	15,400	11,800	11,300	9900	7700	8000	7000	5400	5900	5200	3900	4800	4200	3100		
	Front dozer and rear stabilizers down				*26,900	*26,900	20,200	*19,900	*19,900	12,700	*15,600	*15,600	13,100	8900	*12,400	9800	6700	*9900	8100		5500
5 ft	Front stabilizer and rear dozer up				15,800	14,700	10,600	10,200	9700	7100	7300	6900	5100	5500	5200	3700	4500	4300	3000	33.92	
	Front stabilizer and rear dozer down				*27,100	*27,100	18,100	*19,800	*19,800	11,700	15,000	14,700	8300	11,200	11,000	6300	*8700	*8700	5200		
	2 sets stabilizers up				16,300	14,600	10,800	10,600	9600	7200	7600	6900	5100	5700	5200	3800	4700	4300	3100		
	2 sets stabilizers down				*27,100	*27,100	23,300	*19,800	*19,800	18,800	14,700	*15,200	13,100	10,400	11,500	9900	7900	*8700	8200		6500
	Front dozer and rear stabilizers up				16,400	14,100	10,600	10,700	9300	7100	7600	6600	5100	5700	5000	3700	4700	4100	3000		
	Front dozer and rear stabilizers down				*27,100	*27,100	18,800	*19,800	*19,800	12,000	*15,200	*15,200	12,700	8600	*11,700	9600	6500	*8700	7900		5300
0 ft	Front stabilizer and rear dozer up				15,000	13,900	9900	9800	9200	6600	7000	6700	4900	5400	5100	3600					
	Front stabilizer and rear dozer down				*22,100	*22,100	17,300	*18,100	*18,100	11,200	*13,800	*13,800	8100	*10,200	*10,200	6200					
	2 sets stabilizers up				15,500	13,800	10,000	10,100	9200	6700	7300	6600	4900	5600	5100	3700					
	2 sets stabilizers down				*22,100	*22,100	*22,100	*18,100	*18,100	14,100	*13,800	*13,800	12,800	10,100	*10,200	9700	7700				
	Front dozer and rear stabilizers up				15,600	13,300	9900	10,200	8800	6600	7400	6400	4800	5600	4900	3600					
	Front dozer and rear stabilizers down				*22,100	*22,100	17,900	*18,100	*18,100	11,500	*13,800	*13,800	12,400	8300	*10,200	9400	6300				

*Limited by hydraulic rather than tipping load.

Lift capacity ratings are based on ISO 10567:2007, they do not exceed 87% of hydraulic lifting capacity or 75% of tipping load. The load point is the center line of the bucket pivot mounting pin on the stick. The oscillating axle must be locked. Lifting capacities are based on the machine standing on a firm uniform supporting surface. For lifting capacity including bucket and/or quick coupler, the respective weight has to be subtracted from above values. The use of a work tool attachment point to handle/lift objects, could affect the machine lift performance.

Always refer to the appropriate Operation and Maintenance Manual for specific product information.

Lift Capacities

All values are in kg, without bucket, with counterweight (4200 kg), heavy lift on.



Undercarriage

MH (2.75 m) or MH Narrow (2.55 m)

Boom

5.35 m MH

Stick

4.9 m MH

Stick height	Undercarriage configuration	3000 mm			4500 mm			6000 mm			7500 mm			9000 mm			Load at maximum reach (sticknose/bucket pin)			mm		
		Load point height	Load over front	Load over rear	Load over front	Load over rear	Load over side	Load point height	Load over front	Load over rear	Load over front	Load over rear	Load over side	Load point height	Load over front	Load over rear	Load over front	Load over rear	Load over side			
10500 mm	SA – 2 sets stabilizers up				*6800	*6800	*6800											*6150	*6150	*6150	4830	
	SA – 2 sets stabilizers down				*6800	*6800	*6800											*6150	*6150	*6150		
	Narrow – 2 sets stabilizers up				*6750	*6750	6400											*6200	*6200	5850		
	Narrow – 2 sets stabilizers down				*6750	*6750	*6750											*6200	*6200	*6200		
9000 mm	SA – 2 sets stabilizers up							6250	6250	4800								5000	5000	3800	6910	
	SA – 2 sets stabilizers down							*6800	*6800	*6800								*5000	*5000	*5000		
	Narrow – 2 sets stabilizers up							5700	5700	4300								4550	4550	3400		
	Narrow – 2 sets stabilizers down							*6750	*6750	*6750								*5000	*5000	*5000		
7500 mm	SA – 2 sets stabilizers up							6350	6350	4850	4450	4450	3400					3850	3850	2900	8210	
	SA – 2 sets stabilizers down							*8000	*8000	*8000	*6200	*6200	*6200					*4550	*4550	*4550		
	Narrow – 2 sets stabilizers up							5800	5800	4350	4050	4050	3050					3500	3500	2600		
	Narrow – 2 sets stabilizers down							*8000	*8000	7600	*6200	*6200	5300					*4550	*4550	*4550		
6000 mm	SA – 2 sets stabilizers up							6300	6300	4850	4450	4450	3400	3300	3300	2500		3250	3250	2500	9080	
	SA – 2 sets stabilizers down							*8400	*8400	*8400	*7400	*7400	6850	*4600	*4600	*4600		*4350	*4350	*4350		
	Narrow – 2 sets stabilizers up							5750	5750	4350	4050	4050	3050	3000	3000	2250		2950	2950	2200		
	Narrow – 2 sets stabilizers down							*8400	*8400	7550	7350	7350	5300	*4550	*4550	3950		*4350	*4350	3900		
4500 mm	SA – 2 sets stabilizers up							6150	6150	4700	4400	4400	3350	3300	3300	2500		2950	2950	2250	9630	
	SA – 2 sets stabilizers down							*8800	*8800	*8800	*7500	*7500	6800	6250	6250	5100		*4300	*4300	*4300		
	Narrow – 2 sets stabilizers up							5600	5600	4200	4000	4000	3000	3000	3000	2200		2700	2700	1950		
	Narrow – 2 sets stabilizers down							*8800	*8800	7400	7250	7250	5200	5450	5450	3950		*4300	*4300	3550		
3000 mm	SA – 2 sets stabilizers up							9250	9250	6850	5950	5950	4500	4250	4250	3250	3250	2450	2800	2800	2100	9930
	SA – 2 sets stabilizers down							*11 850	*11 850	*11 850	*9350	*9350	*9350	*7700	*7700	6650	6150	5050	*4350	*4350	4350	
	Narrow – 2 sets stabilizers up							8400	8400	6100	5400	5400	4000	3850	3850	2850	2950	2150	2550	2550	1850	
	Narrow – 2 sets stabilizers down							*11 800	*11 800	11 500	*9350	*9350	7200	7150	7150	5100	5350	5350	3850	*4350	*4350	
1500 mm	SA – 2 sets stabilizers up	17 100	17 100	11 550	8700	8700	6350	5700	5700	4250	4150	4150	3100	3200	3200	2400		2750	2750	2050	9990	
	SA – 2 sets stabilizers down	*19 950	*19 950	*19 950	*13 050	*13 050	*13 050	*9750	*9750	9200	*7700	*7700	6500	6100	6100	4950		*4550	*4550	4250		
	Narrow – 2 sets stabilizers up	15 150	15 150	10 100	7850	7850	5600	5150	5150	3750	3750	3750	2750	2850	2850	2100		2450	2450	1800		
	Narrow – 2 sets stabilizers down	*19 900	*19 900	*19 900	*13 050	*13 050	10 500	*9750	*9750	6900	7000	7000	4950	5300	5300	3800		4550	4550	3250		
0 mm	SA – 2 sets stabilizers up	*8150	*8150	*8150	8250	8250	5900	5450	5450	4000	4000	4000	3000	3100	3100	2350						
	SA – 2 sets stabilizers down	*8150	*8150	*8150	*13 150	*13 150	*13 150	*9600	*9600	8900	*7350	*7350	6350	*5500	*5500	4900						
	Narrow – 2 sets stabilizers up	*8250	*8250	*8250	7350	7350	5200	4900	4900	3550	3600	3600	2650	2800	2800	2050						
	Narrow – 2 sets stabilizers down	*8250	*8250	*8250	*13 150	*13 150	10 350	*9650	*9650	6650	6850	6850	4800	5250	5250	3750						
-1500 mm	SA – 2 sets stabilizers up	*7250	*7250	*7250	7950	7950	5700	5300	5300	3900	3950	3950	2900									
	SA – 2 sets stabilizers down	*7250	*7250	*7250	*11 600	*11 600	*11 600	*8550	*8550	*8550	*6350	*6350	6250									
	Narrow – 2 sets stabilizers up	*7250	*7250	*7250	7100	7100	4950	4750	4750	3400	3550	3550	2550									
	Narrow – 2 sets stabilizers down	*7250	*7250	*7250	*11 650	*11 650	10 050	*8600	*8600	6500	*6350	*6350	4750									

* Limited by hydraulic rather than tipping load.

Lift capacity ratings are based on ISO 10567:2007, they do not exceed 87% of hydraulic lifting capacity or 75% of tipping load. The load point is the center line of the bucket pivot mounting pin on the stick. The oscillating axle must be locked. Lifting capacities are based on the machine standing on a firm uniform supporting surface. For lifting capacity including bucket and/or quick coupler, the respective weight has to be subtracted from above values. The use of a work tool attachment point to handle/lift objects, could affect the machine lift performance.

Always refer to the appropriate Operation and Maintenance Manual for specific product information.

Lift Capacities

All values are in lb, without bucket, with counterweight (9260 lb), heavy lift on.

		Load point height	Load over front	Load over rear	Load over side	Load at maximum reach (sticknose/bucket pin)														
Undercarriage		Boom						Stick												
MH (9'0") or MH Narrow (8'4")		17'7" MH						16'1" MH												
	Undercarriage configuration	10 ft			15 ft			20 ft			25 ft			30 ft				ft		
35 ft	SA – 2 sets stabilizers up																*14,000	*14,000	*14,000	14.76
	SA – 2 sets stabilizers down																*14,000	*14,000	*14,000	
	Narrow – 2 sets stabilizers up																*14,100	*14,100	*14,100	
	Narrow – 2 sets stabilizers down																*14,100	*14,100	*14,100	
30 ft	SA – 2 sets stabilizers up							13,200	13,200	10,100							*11,100	*11,100	8500	22.15
	SA – 2 sets stabilizers down							*14,100	*14,100	*14,100							*11,100	*11,100	7600	
	Narrow – 2 sets stabilizers up							12,000	12,000	9000							10,200	10,200	14,100	
	Narrow – 2 sets stabilizers down							*14,000	*14,000	*14,000							*11,100	*11,100	*11,100	
25 ft	SA – 2 sets stabilizers up							13,500	13,500	10,300	9400	9400	7200				8400	8400	6400	26.64
	SA – 2 sets stabilizers down							*17,300	*17,300	*17,300	*12,800	*12,800	*12,800				*10,000	*10,000	*10,000	
	Narrow – 2 sets stabilizers up							12,300	12,300	9200	8500	8500	6400				7700	7700	5700	
	Narrow – 2 sets stabilizers down							*17,200	*17,200	16,100	*12,700	*12,700	11,200				*10,000	*10,000	*10,000	
20 ft	SA – 2 sets stabilizers up							13,400	13,400	10,200	9400	9400	7200				7100	7100	5400	29.63
	SA – 2 sets stabilizers down							*18,300	*18,300	*18,300	*16,100	*16,100	14,500				*9500	*9500	*9500	
	Narrow – 2 sets stabilizers up							12,200	12,200	9200	8600	8600	6400				6500	6500	4800	
	Narrow – 2 sets stabilizers down							*18,300	*18,300	16,000	15,600	15,600	11,200				*9500	*9500	8500	
15 ft	SA – 2 sets stabilizers up							13,100	13,100	10,000	9300	9300	7100	7000	7000	5300	6400	6400	4800	31.53
	SA – 2 sets stabilizers down							*19,100	*19,100	*19,100	*16,300	*16,300	14,400	*12,800	*12,800	10,800	*9400	*9400	*9400	
	Narrow – 2 sets stabilizers up							11,900	11,900	8900	8400	8400	6300	6300	6300	4600	5800	5800	4300	
	Narrow – 2 sets stabilizers down							*19,100	*19,100	15,700	15,400	15,400	11,100	11,500	11,500	8300	*9400	*9400	7700	
10 ft	SA – 2 sets stabilizers up				19,700	19,700	14,600	12,600	12,600	9500	9000	9000	6800	6900	6900	5200	6100	6100	4500	32.55
	SA – 2 sets stabilizers down				*25,600	*25,600	*25,600	*20,300	*20,300	20,100	*16,600	*16,600	14,100	13,100	13,100	10,700	*9600	*9600	9400	
	Narrow – 2 sets stabilizers up				17,800	17,800	13,000	11,500	11,500	8500	8200	8200	6000	6200	6200	4500	5500	5500	4000	
	Narrow – 2 sets stabilizers down				*25,600	*25,600	24,400	*20,200	*20,200	15,200	15,100	15,100	10,800	11,400	11,400	8200	*9600	*9600	7200	
5 ft	SA – 2 sets stabilizers up	36,200	36,200	24,600	18,500	18,500	13,500	12,100	12,100	9000	8800	8800	6500	6700	6700	5000	5900	5900	4400	32.78
	SA – 2 sets stabilizers down	*43,100	*43,100	*43,100	*28,200	*28,200	*28,200	*21,100	*21,100	19,500	*16,700	*16,700	13,800	12,900	12,900	10,500	*10,000	*10,000	9200	
	Narrow – 2 sets stabilizers up	32,100	32,100	21,400	16,600	16,600	11,900	10,900	10,900	8000	7900	7900	5800	6100	6100	4400	5300	5300	3800	
	Narrow – 2 sets stabilizers down	*43,000	*43,000	*43,000	*28,200	*28,200	23,000	*21,100	*21,100	14,600	14,800	14,800	10,500	11,200	11,200	8000	9900	9900	7100	
0 ft	SA – 2 sets stabilizers up	*18,800	*18,800	*18,800	17,500	17,500	12,500	11,600	11,600	8500	8500	6300	6600	6600	4900					
	SA – 2 sets stabilizers down	*18,800	*18,800	*18,800	*28,500	*28,500	*28,500	*20,800	*20,800	18,900	*15,900	*15,900	13,500	*11,600	*11,600	10,400				
	Narrow – 2 sets stabilizers up	*19,000	*19,000	*19,000	15,600	15,600	11,000	10,400	10,400	7500	7600	7600	5500	5900	5900	4300				
	Narrow – 2 sets stabilizers down	*19,000	*19,000	*19,000	*28,500	*28,500	21,900	20,600	20,600	14,100	14,500	14,500	10,200	11,100	11,100	7900				
-5 ft	SA – 2 sets stabilizers up	*16,400	*16,400	*16,400	16,900	16,900	12,000	11,200	11,200	8200	8300	8300	6100							
	SA – 2 sets stabilizers down	*16,400	*16,400	*16,400	*25,000	*25,000	*25,000	*18,400	*18,400	*18,400	*13,500	*13,500	13,300							
	Narrow – 2 sets stabilizers up	*16,400	*16,400	*16,400	15,100	15,100	10,500	10,100	10,100	7200	7500	7500	5400							
	Narrow – 2 sets stabilizers down	*16,400	*16,400	*16,400	*25,100	*25,100	21,300	*18,500	*18,500	13,800	*13,600	*13,600	10,000							

*Limited by hydraulic rather than tipping load.

Lift capacity ratings are based on ISO 10567:2007, they do not exceed 87% of hydraulic lifting capacity or 75% of tipping load. The load point is the center line of the bucket pivot mounting pin on the stick. The oscillating axle must be locked. Lifting capacities are based on the machine standing on a firm uniform supporting surface. For lifting capacity including bucket and/or quick coupler, the respective weight has to be subtracted from above values. The use of a work tool attachment point to handle/lift objects, could affect the machine lift performance.

Always refer to the appropriate Operation and Maintenance Manual for specific product information.

Lifting Capacities ● MH3022 (Grenoble Sourced)

Material Handlers

Lift Capacities

All values are in kg, without bucket, with counterweight (4200 kg), heavy lift on.

















 Load point height
  Load over front
  Load over rear
  Load over side
  Load at maximum reach (sticknose/bucket pin)

Undercarriage

Boom 5.35 m MH

Stick 4.9 m MH

Standard

Load point height	Undercarriage configuration	3000 mm			4500 mm			6000 mm			7500 mm			9000 mm			mm				
																		mm			
10 500 mm	Front stabilizer and rear dozer up				*6800		*6800										*6150	*6150	4830		
	Front stabilizer and rear dozer down				*6800	*6800	*6800										*6150	*6150			
	2 sets stabilizers up				*6800		*6800										*6150	*6150			
	2 sets stabilizers down				*6800		*6800										*6150	*6150			
	Front dozer and rear stabilizer up				*6800		*6800										*6150	*6150			
Front dozer and rear stabilizer down				*6800	*6800	*6800										*6150	*6150				
9000 mm	Front stabilizer and rear dozer up							6150		4650							4850	3650	6910		
	Front stabilizer and rear dozer down							*6800	*6800	*6800							*5000	*5000			
	2 sets stabilizers up							6300		4650							*5000	3650			
	2 sets stabilizers down							*6800		*6800							*5000	*5000			
	Front dozer and rear stabilizer up							6350		4600							*5000	3650			
Front dozer and rear stabilizer down							*6800	*6800	*6800							*5000	*5000				
7500 mm	Front stabilizer and rear dozer up							6250		4650	4350						3750	2800	8210		
	Front stabilizer and rear dozer down							*8000	*8000	7100	*6200	4950					*4550	*4550			
	2 sets stabilizers up							6400		4700	4450		3300				3850	2800			
	2 sets stabilizers down							*8000		*8000	*6200	5800					*4550	*4550			
	Front dozer and rear stabilizer up							6450		4650	4500		3250				3850	2800			
Front dozer and rear stabilizer down							*8000	*8000	7250	*6200	*6200	5050				*4550	*4550				
6000 mm	Front stabilizer and rear dozer up							6200		4650	4350			3250	3200		2400	3150	9080		
	Front stabilizer and rear dozer down							*8400	*8400	7050	*7400	4950		*4600			*4350	*4350			
	2 sets stabilizers up							6350		4700	4450		3300	3300		2400	3250	2400			
	2 sets stabilizers down							*8400		8350	*7400	5800		*4600		4350	*4350	4250			
	Front dozer and rear stabilizer up							6400		4650	4500		3250	3350		2400	3300	2350			
Front dozer and rear stabilizer down							*8400	*8400	7200	*7400	6900	5050		*4600		3750	*4350				
4500 mm	Front stabilizer and rear dozer up							6050		4500	4250			3200	3200		2400	2850	9630		
	Front stabilizer and rear dozer down							*8800	*8800	6900	*7500	*7500	4900	5900	5800		3650	*4300			
	2 sets stabilizers up							6200		4550	4400		3250	3300		2400	2950	3300			
	2 sets stabilizers down							*8800		8200	*7500	5750	6050		4300	*4300		3850			
	Front dozer and rear stabilizer up							6250		4500	4400		3200	3300		2400	2950	2100			
Front dozer and rear stabilizer down							*8800	*8800	7050	*7500	6850	5000	*6300	5100	3750	*4300	*4300				
3000 mm	Front stabilizer and rear dozer up							9150		6600	5800			3100	3150		2350	2700	9930		
	Front stabilizer and rear dozer down							*11 850	*11 850	10 600	*9350	*9350	6700	*7700	7650	4750	5800	5750		3600	*4350
	2 sets stabilizers up							9400		6650	6000		4350	4250		3100	3250	2350		2800	2000
	2 sets stabilizers down							*11 850		*9350	7950		*7700	5600	6000		4250	*4350			3650
	Front dozer and rear stabilizer up							9450		6600	6000		4300	4300		3100	3250	2350		2800	2000
Front dozer and rear stabilizer down							*11 850	*11 850	10 900	*9350	*9350	6850	*7700	6700	4850	*6350	5050	3700	*4350		
1500 mm	Front stabilizer and rear dozer up	17 300			8600		6050	5550		4050	4000			2950	3100		2250	2650	9990		
	Front stabilizer and rear dozer down	*19 950	*19 950	*19 950	*13 050	10 000	*9750	*9750	6400	7650	7500		4600	5750	5650	3550	*4550	3050			
	2 sets stabilizers up	17 750			8800		6150	5700		4100	4150		3000	3200		2300	2750	1950			
	2 sets stabilizers down	*19 950			*13 050	12 250	*9750	7650	*7700	5450	5900		2950	3200		4200	*4550	3600			
	Front dozer and rear stabilizer up	17 850			8850		6050	5750		4050	4150		2950	3200		2250	2750	1950			
Front dozer and rear stabilizer down	*19 950	*19 950	*19 950	*13 050	*13 050	10 300	*9750	9350	6550	*7700	6550	4700	*6100	5000	3600	*4550	4300				
0 mm	Front stabilizer and rear dozer up	*8150			8100		5650	5300		3850	3900			2850	3000		2200				
	Front stabilizer and rear dozer down	*8150	*8150	*8150	*13 150	*13 150	9500	*9600	*9600	6150	*7350	7350	4500	*5100	*5500	3500					
	2 sets stabilizers up	*8150			8350		5700	5500		3850	4000		2850	3100		2850	3100	2250			
	2 sets stabilizers down	*8150			*13 150	11 700	*9600	7400	*7350	5350	*5500		4100			4100					
	Front dozer and rear stabilizer up	*8150			8400		5650	5500		3850	4050		2850	3150		2200					
Front dozer and rear stabilizer down	*8150	*8150	*8150	*13 150	*13 150	9750	*9600	9050	6300	*7350	6400	4600	*5500	4900	3550						
-1500 mm	Front stabilizer and rear dozer up	*7250			7800		5400	5150		3700	3800			2750							
	Front stabilizer and rear dozer down	*7250	*7250	*7250	*11 600	*11 600	9200	*8550	*8550	6000	*6350	6350	4400								
	2 sets stabilizers up	*7250			8050		5450	5300		3750	3950		2800			2800					
	2 sets stabilizers down	*7250			*11 600	11 350	*8550	7250	*6350	5250						5250					
	Front dozer and rear stabilizer up	*7250			8100		5400	5350		3700	3950		2750			2750					
Front dozer and rear stabilizer down	*7250	*7250	*7250	*11 600	*11 600	9500	*8550	*8550	6150	*6350	6350	4500									

*Limited by hydraulic rather than tipping load.

Lift capacity ratings are based on ISO 10567:2007, they do not exceed 87% of hydraulic lifting capacity or 75% of tipping load. The load point is the center line of the bucket pivot mounting pin on the stick. The oscillating axle must be locked. Lifting capacities are based on the machine standing on a firm uniform supporting surface. For lifting capacity including bucket and/or quick coupler, the respective weight has to be subtracted from above values. The use of a work tool attachment point to handle/lift objects, could affect the machine lift performance.

Always refer to the appropriate Operation and Maintenance Manual for specific product information.

Material Handlers

Lifting Capacities ● MH3022 (Grenoble Sourced)

Lift Capacities

All values are in lb, without bucket, with counterweight (9260 lb), heavy lift on.

		Load point height	Load over front	Load over rear	Load over side	Load at maximum reach (sticknose/bucket pin)													
Undercarriage		Boom						Stick											
Standard		17'7" MH						16'1" MH											
	Undercarriage configuration	10 ft		15 ft		20 ft		25 ft			30 ft				ft				
35 ft	Front stabilizer and rear dozer up															*14,000	*14,000	*14,000	
	Front stabilizer and rear dozer down															*14,000	*14,000	*14,000	
	2 sets stabilizers up															*14,000	*14,000	*14,000	
	2 sets stabilizers down															*14,000	*14,000	*14,000	
	Front dozer and rear stabilizers up															*14,000	*14,000	*14,000	
Front dozer and rear stabilizers down															*14,000	*14,000	*14,000		
30 ft	Front stabilizer and rear dozer up							13,000	12,300	9700						10,900	10,400	8100	
	Front stabilizer and rear dozer down							*14,100	*14,100	*14,100						*11,100	*11,100	*11,100	
	2 sets stabilizers up							13,300	12,300	9800						*11,100	10,400	8200	
	2 sets stabilizers down							*14,100	*14,100	*14,100						*11,100	*11,100	*11,100	
	Front dozer and rear stabilizers up							13,400	11,900	9700						*11,100	10,100	8100	
Front dozer and rear stabilizers down							*14,100	*14,100	*14,100						*11,100	*11,100	*11,100		
25 ft	Front stabilizer and rear dozer up							13,200	12,600	9900	9200	8800	6800			8200	7900	6100	
	Front stabilizer and rear dozer down							*17,300	*17,300	14,700	*12,800	*12,800	10,200			*10,000	*10,000	9200	
	2 sets stabilizers up							13,500	12,500	10,000	9400	8700	6900			8400	7800	6200	
	2 sets stabilizers down							*17,300	*17,300	*17,300	*12,800	*12,800	12,300			*10,000	*10,000	10,000	
	Front dozer and rear stabilizers up							13,600	12,100	9900	9500	8500	6800			8500	7600	6100	
Front dozer and rear stabilizers down							*17,300	*17,300	15,000	*12,800	*12,800	10,400			*10,000	*10,000	9400		
20 ft	Front stabilizer and rear dozer up							13,100	12,500	9800	9200	8800	6900			6900	6600	5100	
	Front stabilizer and rear dozer down							*18,300	*18,300	14,600	*16,100	*16,100	10,200			*9500	*9500	7700	
	2 sets stabilizers up							13,500	12,400	9900	9400	8700	6900			7100	6600	5200	
	2 sets stabilizers down							*18,300	*18,300	17,700	*16,100	15,100	12,300			*9500	*9500	9300	
	Front dozer and rear stabilizers up							13,500	12,100	9800	9500	8500	6900			7200	6400	5100	
Front dozer and rear stabilizers down							*18,300	*18,300	15,000	*16,100	14,700	10,500			*9500	*9500	7900		
15 ft	Front stabilizer and rear dozer up							12,800	12,200	9500	9000	8700	6700	6700	6500	5000	6200	6000	4600
	Front stabilizer and rear dozer down							*19,100	*19,100	14,300	*16,300	*16,300	10,100	12,500	12,300	7600	*9400	*9400	7000
	2 sets stabilizers up							13,200	12,200	9600	9300	8600	6800	7000	6400	5100	6400	5900	4600
	2 sets stabilizers down							*19,100	*19,100	17,400	*16,300	14,900	12,200	12,800	11,200	9100	*9400	*9400	8400
	Front dozer and rear stabilizers up							13,300	11,800	9500	9400	8300	6700	7000	6200	5000	6400	5700	4600
Front dozer and rear stabilizers down							*19,100	*19,100	14,700	*16,300	14,500	10,300	*12,800	10,800	7700	*9400	*9400	7100	
10 ft	Front stabilizer and rear dozer up				19,500	18,200	14,000	12,300	11,700	9100	8800	8400	6500	6600	6400	4900	5800	5600	4300
	Front stabilizer and rear dozer down				*25,600	*25,600	21,800	*20,300	*20,300	13,800	16,500	16,200	9800	12,300	12,200	7500	*9600	*9600	6600
	2 sets stabilizers up				20,000	18,200	14,100	12,700	11,700	9200	9000	8400	6600	6800	6300	4900	6000	5600	4300
	2 sets stabilizers down				*25,600	*25,600	*20,300	*20,300	16,900	*16,600	14,700	11,900	12,700	11,000	9000	*9600	*9600	7900	
	Front dozer and rear stabilizers up				20,100	17,600	14,000	12,800	11,300	9100	9100	8100	6500	6900	6100	4900	6100	5400	4300
Front dozer and rear stabilizers down				*25,600	*25,600	22,600	*20,300	*20,300	14,200	*16,600	14,200	10,100	*13,600	10,700	7600	*9600	9400	6700	
5 ft	Front stabilizer and rear dozer up	36,500	32,800	23,500	18,200	17,000	12,900	11,800	11,200	8600	8500	8100	6200	6500	6200	4800	5700	5500	4200
	Front stabilizer and rear dozer down	*43,100	*43,100	42,200	*28,200	*28,200	20,500	*21,100	*21,100	13,200	16,200	15,900	9500	12,200	12,000	7300	*10,000	*10,000	6400
	2 sets stabilizers up	37,500	32,600	23,800	18,700	17,000	13,000	12,100	11,100	8700	8800	8100	6300	6700	6200	4800	5900	5500	4200
	2 sets stabilizers down	*43,100	*43,100	*43,100	*28,200	*28,200	25,900	*21,100	20,400	16,200	16,600	14,300	11,600	12,500	10,900	8900	*10,000	9600	7800
	Front dozer and rear stabilizers up	37,800	31,700	23,500	18,800	16,400	12,900	12,200	10,800	8600	8800	7800	6200	6800	6000	4800	5900	5300	4200
Front dozer and rear stabilizers down	*43,100	*43,100	*43,100	*28,200	*28,200	21,200	*21,100	19,800	13,600	*16,700	13,900	9800	*13,100	10,600	7500	*10,000	9300	6600	
0 ft	Front stabilizer and rear dozer up	*18,800	*18,800	*18,800	17,200	16,000	11,900	11,300	10,700	8100	8200	7900	6000	6400	6100	4600			
	Front stabilizer and rear dozer down	*18,800	*18,800	*18,800	*28,500	*28,500	19,500	*20,800	*20,800	12,700	*15,900	15,600	9300	*11,600	*11,600	7200			
	2 sets stabilizers up	*18,800	*18,800	*18,800	17,700	16,000	12,100	11,600	10,600	8200	8500	7800	6000	6600	6100	4700			
	2 sets stabilizers down	*18,800	*18,800	*18,800	*28,500	*28,500	24,700	*20,800	19,800	15,700	*15,900	14,000	11,300	*11,600	10,800	8700			
	Front dozer and rear stabilizers up	*18,800	*18,800	*18,800	17,800	15,400	11,900	11,700	10,300	8100	7600	6000	6000	6600	5900	4600			
Front dozer and rear stabilizers down	*18,800	*18,800	*18,800	*28,500	*28,500	20,100	*20,800	19,200	13,100	*15,900	13,600	9500	*11,600	10,400	7400				
-5 ft	Front stabilizer and rear dozer up	*16,400	*16,400	*16,400	16,600	15,500	11,400	10,900	10,400	7800	8100	7700	5800						
	Front stabilizer and rear dozer down	*16,400	*16,400	*16,400	*25,000	18,900	*18,400	*18,400	12,400	*13,500	*13,500	9100							
	2 sets stabilizers up	*16,400	*16,400	*16,400	17,100	15,400	11,600	11,300	10,300	7900	8300	7700	5900						
	2 sets stabilizers down	*16,400	*16,400	*16,400	*25,000	*25,000	24,100	*18,400	*18,400	15,300	*13,500	*13,500	11,100						
	Front dozer and rear stabilizers up	*16,400	*16,400	*16,400	17,200	14,900	11,400	11,400	10,000	7800	8400	7400	5800						
Front dozer and rear stabilizers down	*16,400	*16,400	*16,400	*25,000	*25,000	19,500	*18,400	*18,400	12,700	*13,500	13,400	9300							

*Limited by hydraulic rather than tipping load.

Lift capacity ratings are based on ISO 10567:2007, they do not exceed 87% of hydraulic lifting capacity or 75% of tipping load. The load point is the center line of the bucket pivot mounting pin on the stick. The oscillating axle must be locked. Lifting capacities are based on the machine standing on a firm uniform supporting surface. For lifting capacity including bucket and/or quick coupler, the respective weight has to be subtracted from above values. The use of a work tool attachment point to handle/lift objects, could affect the machine lift performance.

Always refer to the appropriate Operation and Maintenance Manual for specific product information.

Lift Capacities

All values are in kg, bucket cylinder and linkage installed, without bucket, with counterweight (4200 kg), heavy lift on.



Undercarriage

MH (2.75 m) or MH Narrow (2.55 m)

Boom

5.35 m MH

Stick

4.2 m Straight Stick

Stick height	Undercarriage configuration	3000 mm			4500 mm			6000 mm			7500 mm			9000 mm			Stick			mm
		Load point height	Load over front	Load over rear	Load over front	Load over rear	Load over side	Load over front	Load over rear	Load over side	Load over front	Load over rear	Load over side	Load over front	Load over rear	Load over side	Load at maximum reach (sticknose/bucket pin)	Load at maximum reach (sticknose/bucket pin)	Load at maximum reach (sticknose/bucket pin)	
9000 mm	SA – 2 sets stabilizers up				*8500	*8500	6950											*5750	*5750	4400
	SA – 2 sets stabilizers down				*8500	*8500	*8500											*5750	*5750	*5750
	Narrow – 2 sets stabilizers up				*8500	*8500	6200											5400	5400	3950
	Narrow – 2 sets stabilizers down				*8500	*8500	*8500											*5800	*5800	*5800
7500 mm	SA – 2 sets stabilizers up							5900	5900	4450								4150	4150	3050
	SA – 2 sets stabilizers down							*8250	*8250	*8250								*5100	*5100	*5100
	Narrow – 2 sets stabilizers up							5350	5350	3950								3750	3750	2700
	Narrow – 2 sets stabilizers down							*8200	*8200	7150								*5100	*5100	5000
6000 mm	SA – 2 sets stabilizers up							5900	5900	4400	4050	4050	3000					3350	3350	2450
	SA – 2 sets stabilizers down							*8600	*8600	*8600	*7300	*7300	6450					*4800	*4800	*4800
	Narrow – 2 sets stabilizers up							5350	5350	3900	3650	3650	2650					3050	3050	2150
	Narrow – 2 sets stabilizers down							*8600	*8600	7100	6950	6950	4900					*4800	*4800	4050
4500 mm	SA – 2 sets stabilizers up				9200	9200	6750	5750	5750	4250	4000	4000	2950					2950	2950	2150
	SA – 2 sets stabilizers down				*11 100	*11 100	*11 100	*8900	*8900	*8900	*7350	*7350	6400					*4750	*4750	*4750
	Narrow – 2 sets stabilizers up				8300	8300	6000	5200	5200	3800	3600	3600	2600					2650	2650	1850
	Narrow – 2 sets stabilizers down				*11 050	*11 050	*11 050	*8900	*8900	7000	6850	6850	4850					*4750	*4750	3600
3000 mm	SA – 2 sets stabilizers up	17 750	17 750	12 050	8700	8700	6300	5500	5500	4050	3900	3900	2850	2900	2900	2100	2900	2750	2750	2000
	SA – 2 sets stabilizers down	*18 000	*18 000	*18 000	*12 250	*12 250	*12 250	*9300	*9300	9050	*7400	*7400	6250	*5750	*5750	4650	*4850	*4850	4450	
	Narrow – 2 sets stabilizers up	15 750	15 750	10 550	7850	7850	5600	4950	4950	3600	3500	3500	2500	2600	2600	1800	2450	2450	1700	
	Narrow – 2 sets stabilizers down	*17 950	*17 950	*17 950	*12 200	*12 200	10 900	*9300	*9300	6750	6750	6750	4700	5000	5000	3500	4800	4800	3350	
1500 mm	SA – 2 sets stabilizers up	*11 900	*11 900	10 650	8150	8150	5850	5250	5250	3850	3750	3750	2750	2850	2850	2050	2700	2700	1950	
	SA – 2 sets stabilizers down	*11 900	*11 900	*11 900	*12 950	*12 950	*12 950	*9450	*9450	8750	*7250	*7250	6150	*5300	*5300	4600	*4750	*4750	4400	
	Narrow – 2 sets stabilizers up	*12 350	*12 350	9200	7300	7300	5100	4750	4750	3350	3350	3350	2400	2550	2550	1750	2400	2400	1650	
	Narrow – 2 sets stabilizers down	*12 350	*12 350	*12 350	*12 950	*12 950	10 300	*9450	*9450	6450	6600	6600	4600	4950	4950	3450	4700	4700	3300	
0 mm	SA – 2 sets stabilizers up	*6250	*6250	*6250	7750	7750	5450	5050	5050	3650	3650	3650	2650							
	SA – 2 sets stabilizers down	*6250	*6250	*6250	*12 250	*12 250	*12 250	*8900	*8900	8500	*6600	*6600	6000							
	Narrow – 2 sets stabilizers up	*6250	*6250	*6250	6900	6900	4750	4550	4550	3150	3250	3250	2300							
	Narrow – 2 sets stabilizers down	*6250	*6250	*6250	*12 300	*12 300	9850	*8900	*8900	6250	6500	6500	4500							
-1500 mm	SA – 2 sets stabilizers up				7600	7600	5300	4950	4950	3550										
	SA – 2 sets stabilizers down				*9850	*9850	*9850	*7300	*7300	*7300										
	Narrow – 2 sets stabilizers up				6700	6700	4550	4400	4400	3050										
	Narrow – 2 sets stabilizers down				*9950	*9950	9650	*7350	*7350	6150										

*Limited by hydraulic rather than tipping load.

Lift capacity ratings are based on ISO 10567:2007, they do not exceed 87% of hydraulic lifting capacity or 75% of tipping load. The load point is the center line of the bucket pivot mounting pin on the stick. The oscillating axle must be locked. Lifting capacities are based on the machine standing on a firm uniform supporting surface. For lifting capacity including bucket and/or quick coupler, the respective weight has to be subtracted from above values. The use of a work tool attachment point to handle/lift objects, could affect the machine lift performance.

Always refer to the appropriate Operation and Maintenance Manual for specific product information.

Lift Capacities

All values are in lb, bucket cylinder and linkage installed, without bucket, with counterweight (9260 lb), heavy lift on.

		Load point height	Load over front	Load over rear	Load over side	Load at maximum reach (sticknose/bucket pin)														
		Undercarriage			Boom 17'7" MH			Stick 13'9" Straight Stick												
		MH (9'0") or MH Narrow (8'4")			20 ft			25 ft			30 ft									
	Undercarriage configuration	10 ft			15 ft			20 ft			25 ft			30 ft			ft			
30 ft	SA – 2 sets stabilizers up				*18,200	*18,200	14,700									*12,900	*12,900	10,100		
	SA – 2 sets stabilizers down				*18,200	*18,200	*18,200									*12,900	*12,900	*12,900		
	Narrow – 2 sets stabilizers up				18,000	18,000	13,100									12,400	12,400	9100		
	Narrow – 2 sets stabilizers down				*18,100	*18,100	*18,100									*13,000	*13,000	*13,000		
25 ft	SA – 2 sets stabilizers up							12,500	12,500	9400							9200	9200	6800	
	SA – 2 sets stabilizers down							*17,600	*17,600	*17,600							*11,300	*11,300	*11,300	
	Narrow – 2 sets stabilizers up							11,300	11,300	8300							8300	8300	6000	
	Narrow – 2 sets stabilizers down							*17,500	*17,500	15,200							*11,300	*11,300	11,200	
20 ft	SA – 2 sets stabilizers up							12,500	12,500	9300	8600	8600	6400				7400	7400	5400	
	SA – 2 sets stabilizers down							*18,700	*18,700	*18,700	*15,500	*15,500	13,700				*10,600	*10,600	*10,600	
	Narrow – 2 sets stabilizers up							11,300	11,300	8300	7700	7700	5600				6700	6700	4700	
	Narrow – 2 sets stabilizers down							*18,700	*18,700	15,100	14,700	14,700	10,400				*10,600	*10,600	9000	
15 ft	SA – 2 sets stabilizers up					19,600	19,600	14,400	12,200	12,200	9100	8500	8500	6300				6500	6500	4700
	SA – 2 sets stabilizers down					*24,000	*24,000	*24,000	*19,300	*19,300	*19,300	*16,000	*16,000	13,600				*10,500	*10,500	10,400
	Narrow – 2 sets stabilizers up					17,700	17,700	12,800	11,000	11,000	8000	7600	7600	5500				5800	5800	4100
	Narrow – 2 sets stabilizers down					*24,000	*24,000	*24,000	*19,300	*19,300	14,800	14,600	14,600	10,300				*10,500	*10,500	7900
10 ft	SA – 2 sets stabilizers up	37,700	37,700	25,700	18,500	18,500	13,500	11,700	11,700	8600	8300	8300	6000	6100	6100	4400	6000	6000	4300	
	SA – 2 sets stabilizers down	*38,800	*38,800	*38,800	*26,500	*26,500	*26,500	*20,200	*20,200	19,200	*16,000	*16,000	13,300	*12,000	*12,000	9900	*10,700	*10,700	9700	
	Narrow – 2 sets stabilizers up	33,400	33,400	22,500	16,700	16,700	11,900	10,600	10,600	7600	7400	7400	5300	5500	5500	3800	5400	5400	3700	
	Narrow – 2 sets stabilizers down	*38,700	*38,700	*38,700	*26,400	*26,400	23,200	*20,200	*20,200	14,300	14,400	14,400	10,000	10,600	10,600	7400	10,500	10,500	7300	
5 ft	SA – 2 sets stabilizers up	*29,500	*29,500	22,700	17,400	17,400	12,400	11,200	11,200	8100	8000	8000	5800	6000	6000	4300	5900	5900	4200	
	SA – 2 sets stabilizers down	*29,500	*29,500	*29,500	*28,000	*28,000	*28,000	*20,500	*20,500	18,600	*15,600	*15,600	13,000	*11,200	*11,200	9800	*10,500	*10,500	9500	
	Narrow – 2 sets stabilizers up	30,000	30,000	19,500	15,500	15,500	10,800	10,000	10,000	7100	7200	7200	5000	5400	5400	3700	5200	5200	3600	
	Narrow – 2 sets stabilizers down	*30,800	*30,800	*30,800	*28,000	*28,000	21,900	20,300	20,300	13,800	14,100	14,100	9700	10,500	10,500	7300	10,200	10,200	7100	
0 ft	SA – 2 sets stabilizers up	*14,400	*14,400	*14,400	16,500	16,500	11,600	10,800	10,800	7700	7800	7800	5600							
	SA – 2 sets stabilizers down	*14,400	*14,400	*14,400	*26,600	*26,600	*26,600	*19,200	*19,200	18,100	*14,100	*14,100	12,800							
	Narrow – 2 sets stabilizers up	*14,400	*14,400	*14,400	14,700	14,700	10,100	9600	9600	6700	6900	6900	4800							
	Narrow – 2 sets stabilizers down	*14,400	*14,400	*14,400	*26,700	*26,700	20,900	*19,300	*19,300	13,300	13,800	13,800	9500							
-5 ft	SA – 2 sets stabilizers up				16,100	16,100	11,200	10,500	10,500	7500										
	SA – 2 sets stabilizers down				*21,300	*21,300	*21,300	*15,700	*15,700	*15,700										
	Narrow – 2 sets stabilizers up				14,300	14,300	9700	9400	9400	6500										
	Narrow – 2 sets stabilizers down				*21,500	*21,500	20,500	*15,800	*15,800	13,000										

*Limited by hydraulic rather than tipping load.

Lift capacity ratings are based on ISO 10567:2007, they do not exceed 87% of hydraulic lifting capacity or 75% of tipping load. The load point is the center line of the bucket pivot mounting pin on the stick. The oscillating axle must be locked. Lifting capacities are based on the machine standing on a firm uniform supporting surface. For lifting capacity including bucket and/or quick coupler, the respective weight has to be subtracted from above values. The use of a work tool attachment point to handle/lift objects, could affect the machine lift performance.

Always refer to the appropriate Operation and Maintenance Manual for specific product information.

Lift Capacities

All values are in kg, bucket cylinder and linkage installed, without bucket, with counterweight (4200 kg), heavy lift on.

Load point height

Load over front

Load over rear

Load over side

Load at maximum reach (sticknose/bucket pin)

Undercarriage

Boom
5.35 m MH

Stick
4.2 m Straight Stick

Standard

	Undercarriage configuration	3000 mm			4500 mm			6000 mm			7500 mm			9000 mm				mm	
9000 mm	Front stabilizer and rear dozer up				*8550		6700										*5750		4200
	Front stabilizer and rear dozer down				*8550	*8550	*8550										*5750	*5750	*5750
	2 sets stabilizers up				*8550		6750										*5750		4250
	2 sets stabilizers down				*8550		*8550										*5750		*5750
	Front dozer and rear stabilizer up				*8550		6700										*5750		4200
Front dozer and rear stabilizer down				*8550	*8550	*8550										*5750	*5750	*5750	
7500 mm	Front stabilizer and rear dozer up						5800			4250							4000		2900
	Front stabilizer and rear dozer down						*8250	*8250	6650							*5100	*5100	4650	
	2 sets stabilizers up						5950			4300							4150		2950
	2 sets stabilizers down						*8250	*8250	7950							*5100	*5100	*5100	
	Front dozer and rear stabilizer up						6000			4250							4150		2900
Front dozer and rear stabilizer down						*8250	*8250	6800							*5100	*5100	4750		
6000 mm	Front stabilizer and rear dozer up						5750			4200	3950		2850				3250		2350
	Front stabilizer and rear dozer down						*8600	*8600	6600	*7300	*7300	4550				*4800	*4800	3800	
	2 sets stabilizers up						5900			4250	4050	2900				3350		2350	
	2 sets stabilizers down						*8600	*8600	7900	*7300	*7300	5400				*4800	*4800	4500	
	Front dozer and rear stabilizer up						5950			4200	4100	2850				3400		2350	
Front dozer and rear stabilizer down						*8600	*8600	6800	*7300	6500	4650				*4800	*4800	3850		
4500 mm	Front stabilizer and rear dozer up						9100			5600	4100	3900				2850		2050	
	Front stabilizer and rear dozer down				*11 100	*11 100	10 550	*8900	*8900	6500	*7350	4500				*4750	*4750	3350	
	2 sets stabilizers up						9350			5800	4100	4000				2950		2050	
	2 sets stabilizers down				*11 100	*11 100	*8900	*8900	7750	*7350	*7350	5350				*4750	*4750	4000	
	Front dozer and rear stabilizer up						9400			5800	4100	4050				3000		2050	
Front dozer and rear stabilizer down				*11 100	*11 100	10 850	*8900	*8900	6650	*7350	6450	4600				*4750	*4750	3400	
3000 mm	Front stabilizer and rear dozer up	18 000		11 550	8600	6050	5400	3850	3750			2700	2800		1950	2650	1850		
	Front stabilizer and rear dozer down	*18 000	*18 000	*18 000	*12 250	*12 250	*9300	*9300	6250	7400	7250	4400	5450	5400	3250	*4850	*4850	3100	
	2 sets stabilizers up	18 000		11 700	8850	6100	5550	3900	3900			2750	2900	2000	2750		1900		
	2 sets stabilizers down	*18 000		*12 250	*12 250	*12 250	*9300	7500	*7400			5250	5600	3900	*4850		3700		
	Front dozer and rear stabilizer up	18 000		11 550	8900	6050	5600	3850	3900			2700	2900	1950	2750		1850		
Front dozer and rear stabilizer down	*18 000	*18 000	*18 000	*12 250	*12 250	10 300	*9300	9200	6400	*7400	6350	4500	*5750	4700	3350	*4850	4500	3200	
1500 mm	Front stabilizer and rear dozer up	*11 900		10 150	8050	5550	5150	3850	3850			2600	2750		1950	2600	1800		
	Front stabilizer and rear dozer down	*11 900	*11 900	*11 900	*12 950	*12 950	9450	*9450	6000	*7250	7100	4250	*5300	*5300	3200	*4750	*4750	3050	
	2 sets stabilizers up	*11 900		10 300	8250	5600	5300	3700	3750			2600	2850		1950	2700	1850		
	2 sets stabilizers down	*11 900		*11 900	*12 950	*12 950	11 650	*9450	7200	*7250		5100	*5300	3850	*4750		3650		
	Front dozer and rear stabilizer up	*11 900		10 150	8300	5550	5350	3650	3800			2600	2850		1950	2700	1800		
Front dozer and rear stabilizer down	*11 900	*11 900	*11 900	*12 950	*12 950	9700	*9450	8900	6150	*7250	6200	4350	*5300	4650	3300	*4750	4400	3100	
0 mm	Front stabilizer and rear dozer up	*6250		*6250	7600	5200	4950	3450	3550			2500							
	Front stabilizer and rear dozer down	*6250	*6250	*6250	*12 250	*12 250	9000	*8900	*8900	5800	*6600	4150							
	2 sets stabilizers up	*6250		*6250	7850	5250	5100	3500	3650			2550							
	2 sets stabilizers down	*6250		*6250	*12 250	11 200	*8900	7000	*6600			5000							
	Front dozer and rear stabilizer up	*6250		*6250	7900	5200	5150	3450	3700			2500							
Front dozer and rear stabilizer down	*6250	*6250	*6250	*12 250	*12 250	9300	*8900	8650	5900	*6600	6050	4250							
-1500 mm	Front stabilizer and rear dozer up				7450	5000	4800	3350											
	Front stabilizer and rear dozer down				*9850	*9850	8800	*7300	*7300	5650									
	2 sets stabilizers up				7700	5100	5000	3400											
	2 sets stabilizers down				*9850	*9850	*9850	*7300		6900									
	Front dozer and rear stabilizer up				7750	5000	5000	3350											
Front dozer and rear stabilizer down				*9850	*9850	9100	*7300	*7300	5800										

9

*Limited by hydraulic rather than tipping load.

Lift capacity ratings are based on ISO 10567:2007, they do not exceed 87% of hydraulic lifting capacity or 75% of tipping load. The load point is the center line of the bucket pivot mounting pin on the stick. The oscillating axle must be locked. Lifting capacities are based on the machine standing on a firm uniform supporting surface. For lifting capacity including bucket and/or quick coupler, the respective weight has to be subtracted from above values. The use of a work tool attachment point to handle/lift objects, could affect the machine lift performance.

Always refer to the appropriate Operation and Maintenance Manual for specific product information.

Lift Capacities

All values are in lb, bucket cylinder and linkage installed, without bucket, with counterweight (9260 lb), heavy lift on.

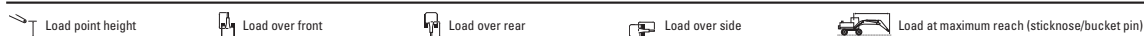

Undercarriage

Boom

Stick

Standard

17'7" MH

13'9" Straight Stick

Stick ft	Undercarriage configuration	10 ft			15 ft			20 ft			25 ft			30 ft			ft							
		Load point height	Load over front	Load over rear	Load point height	Load over front	Load over rear	Load point height	Load over front	Load over rear	Load point height	Load over front	Load over rear	Load point height	Load over front	Load over rear								
30 ft	Front stabilizer and rear dozer up				*18,200	*18,200	14,100																	
	Front stabilizer and rear dozer down				*18,200	*18,200	*18,200																	
	2 sets stabilizers up				*18,200	*18,200	14,300																	
	2 sets stabilizers down				*18,200	*18,200	*18,200																	
	Front dozer and rear stabilizers up				*18,200	17,900	14,100																	
Front dozer and rear stabilizers down				*18,200	*18,200	*18,200																		
25 ft	Front stabilizer and rear dozer up							12,300	11,600	9000											8900	8500	6500	
	Front stabilizer and rear dozer down							*17,600	*17,600	13,700											*11,300	*11,300	10,000	
	2 sets stabilizers up							12,600	11,600	9100											9200	8500	6500	
	2 sets stabilizers down							*17,600	*17,600	16,800											*11,300	*11,300	11,300	
	Front dozer and rear stabilizers up							12,700	11,200	9000											9300	8200	6500	
Front dozer and rear stabilizers down							*17,600	*17,600	14,100											*11,300	*11,300	10,300		
20 ft	Front stabilizer and rear dozer up							12,200	11,600	8900	8300	8000	6000								7200	6800	5100	
	Front stabilizer and rear dozer down							*18,700	*18,700	13,700	*15,500	*15,500	9400								*10,600	*10,600	8100	
	2 sets stabilizers up							12,600	11,500	9000	8600	7900	6100								7400	6800	5200	
	2 sets stabilizers down							*18,700	*18,700	16,800	*15,500	14,200	11,500								*10,600	*10,600	9900	
	Front dozer and rear stabilizers up							12,600	11,200	8900	8700	7600	6000								7400	6600	5100	
Front dozer and rear stabilizers down							*18,700	*18,700	14,100	*15,500	13,800	9600								*10,600	*10,600	8300		
15 ft	Front stabilizer and rear dozer up						19,300	18,100	13,800	11,900	11,300	8700	8200	7800	5900							6200	6000	4400
	Front stabilizer and rear dozer down						*24,000	*24,000	21,700	*19,300	*19,300	13,400	*16,000	15,700	9300							*10,500	*10,500	7100
	2 sets stabilizers up						19,800	18,000	13,900	12,300	11,300	8800	8500	7800	6000							6500	5900	4500
	2 sets stabilizers down						*24,000	*24,000	*24,000	*19,300	*19,300	16,500	*16,000	14,100	11,300							*10,500	*10,500	8700
	Front dozer and rear stabilizers up						19,900	17,500	13,800	12,400	10,900	8700	8500	7500	5900							6500	5700	4400
Front dozer and rear stabilizers down						*24,000	*24,000	22,400	*19,300	*19,300	13,800	*16,000	13,700	9500							*10,500	*10,500	7300	
10 ft	Front stabilizer and rear dozer up	38,100	34,200	24,600	18,300	17,100	12,900	11,500	10,900	8200	8000	7600	5700	5900	5600	4200						5800	5500	4100
	Front stabilizer and rear dozer down	*38,800	*38,800	*38,800	*26,500	*26,500	20,600	*20,200	*20,200	12,900	15,700	15,400	9000	11,600	11,400	6700						*10,700	*10,700	6600
	2 sets stabilizers up	*38,800	34,000	24,900	18,800	17,000	13,000	11,800	10,800	8300	8300	7600	5800	6100	5600	4200						6000	5500	4100
	2 sets stabilizers down	*38,800	*38,800	*38,800	*26,500	*26,500	26,100	*20,200	20,100	15,900	*16,000	13,900	11,100	11,900	10,300	8300						*10,700	10,100	8100
	Front dozer and rear stabilizers up	*38,800	33,000	24,600	18,900	16,500	12,900	11,900	10,400	8200	8300	7300	5700	6200	5400	4200						6000	5300	4100
Front dozer and rear stabilizers down	*38,800	*38,800	*38,800	*26,500	*26,500	21,300	*20,200	19,500	13,300	*16,000	13,400	9300	*12,000	10,000	6900						*10,700	9800	6800	
5 ft	Front stabilizer and rear dozer up	*29,500	*29,500	21,600	17,100	15,900	11,800	10,900	10,300	7700	7700	7400	5500	5800	5500	4100						5600	5400	3900
	Front stabilizer and rear dozer down	*29,500	*29,500	*29,500	*28,000	*28,000	19,400	*20,500	*20,500	12,400	15,400	15,100	8800	*11,200	*11,200	6600						*10,500	*10,500	6400
	2 sets stabilizers up	*29,500	*29,500	21,800	17,600	15,800	11,900	11,300	10,300	7800	8000	7300	5600	6000	5500	4100						5800	5300	4000
	2 sets stabilizers down	*29,500	*29,500	*29,500	*28,000	*28,000	24,700	*20,500	19,500	15,400	*15,600	13,600	10,800	*11,200	10,200	8200						*10,500	9900	7900
	Front dozer and rear stabilizers up	*29,500	*29,500	21,600	17,700	15,300	11,800	11,300	9900	7700	8100	7100	5500	6100	5300	4100						5900	5100	3900
Front dozer and rear stabilizers down	*29,500	*29,500	*29,500	*28,000	*28,000	20,100	*20,500	18,900	12,700	*15,600	13,200	9000	*11,200	9900	6800						*10,500	9600	6600	
0 ft	Front stabilizer and rear dozer up	*14,400	*14,400	*14,400	16,200	15,100	11,000	10,500	9900	7300	7500	7200	5300											
	Front stabilizer and rear dozer down	*14,400	*14,400	*14,400	*26,600	*26,600	18,500	*19,200	*19,200	11,900	*14,100	*14,100	8600											
	2 sets stabilizers up	*14,400	*14,400	*14,400	16,700	15,000	11,100	10,800	9800	7400	7800	7100	5300											
	2 sets stabilizers down	*14,400	*14,400	*14,400	*26,600	*26,600	23,700	*19,200	19,000	14,900	*14,100	13,300	10,600											
	Front dozer and rear stabilizers up	*14,400	*14,400	*14,400	16,800	14,500	11,000	10,900	9500	7300	7800	6900	5300											
Front dozer and rear stabilizers down	*14,400	*14,400	*14,400	*26,600	*26,600	19,100	*19,200	18,400	12,300	*14,100	12,900	8800												
-5 ft	Front stabilizer and rear dozer up						15,800	14,700	10,600	10,200	9700	7100												
	Front stabilizer and rear dozer down						*21,300	*21,300	18,100	*15,700	*15,700	11,700												
	2 sets stabilizers up						16,300	14,600	10,800	10,600	9600	7200												
	2 sets stabilizers down						*21,300	*21,300	*21,300	*15,700	*15,700	14,600												
	Front dozer and rear stabilizers up						16,400	14,100	10,600	10,700	9300	7100												
Front dozer and rear stabilizers down						*21,300	*21,300	18,700	*15,700	*15,700	12,000													

*Limited by hydraulic rather than tipping load.

Lift capacity ratings are based on ISO 10567:2007, they do not exceed 87% of hydraulic lifting capacity or 75% of tipping load. The load point is the center line of the bucket pivot mounting pin on the stick. The oscillating axle must be locked. Lifting capacities are based on the machine standing on a firm uniform supporting surface. For lifting capacity including bucket and/or quick coupler, the respective weight has to be subtracted from above values. The use of a work tool attachment point to handle/lift objects, could affect the machine lift performance.

Always refer to the appropriate Operation and Maintenance Manual for specific product information.

Specifications
Range Dimensions
● MH3024
(Grenoble Sourced)

Material Handlers

MH3024 Specifications

Model	MH3024	
Operating Weight	23 500-26 500 kg	51,809-58,422 lb
Rated Power (ISO 14396)	129 kW	173 hp
Engine Model	C7.1 ACERT	
Emissions	U.S. EPA Tier 4 Final, EU Stage IV, Japan 2014 (Tier 4 Final)	
Maximum Travel Speed	25 km/h	15.5 mph
Fuel Tank Refill Capacity	420 L	111.0 U.S. gal
Eye Level Height (Cab Fully Raised)	4850 mm	15'11"
Tail Swing Radius	2825 mm	9'3"

MH3024 Range Diagram

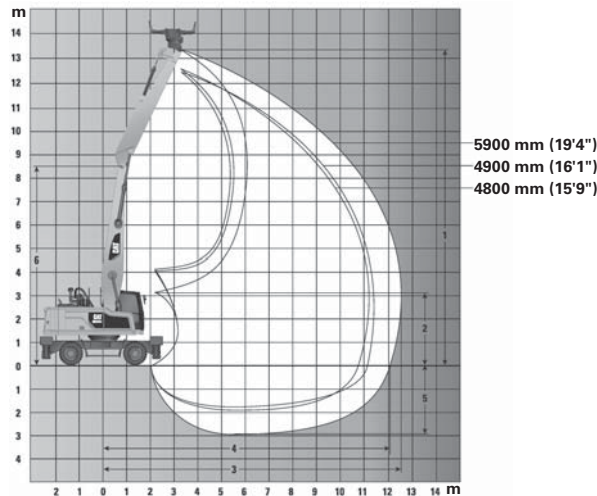

Undercarriage

Special Application MH Undercarriage

Wheel Base	2750 mm (9'0")				
Width over Tires (10.00-20 Solid)	2700 mm (8'10")				
Boom – Boom Length	Standard MH Boom – 6800 mm (22'4")				
Stick – Stick Length	MH Drop Nose Stick – 4900 mm (16'1")		MH Drop Nose Stick – 5900 mm (19'4")		MH Straight Stick – 4800 mm (15'9")
1 Maximum Vertical Pin Height	12 500 mm	41'0"	13 300 mm	43'8"	12 400 mm 40'8"
2 Minimum Dump Height	4025 mm	13'2"	3090 mm	10'1"	4120 mm 13'6"
3 Maximum Horizontal Reach	11 500 mm	37'9"	12 500 mm	41'0"	11 400 mm 37'5"
4 Maximum Reach at Ground Level	10 850 mm	35'7"	12 050 mm	39'6"	11 250 mm 36'10"
5 Maximum Depth	1920 mm	6'3"	2925 mm	9'7"	1825 mm 5'11"
6 Boom Pin Height	8620 mm	28'3"	8620 mm	28'3"	8620 mm 28'3"

Lift Capacities

All values are in kg, bucket cylinder and linkage installed, hydraulic cab riser, work tool: none, with counterweight (4100 kg), heavy lift on.



Undercarriage

Boom

Stick

MH or Standard

One-Piece

2.5 m

Stick mm	Undercarriage configuration	3000 mm			4500 mm			6000 mm			7500 mm			mm
		Load over front	Load over rear	Load over side	Load over front	Load over rear	Load over side	Load over front	Load over rear	Load over side	Load over front	Load over rear	Load over side	
7500 mm	MH – stabilizers up – solid tires													
	MH – stabilizers down – solid tires													
	Lower (std UC) – f. stabilizer & r. dozer up													
	Lower (std UC) – f. stabilizer & r. dozer down													
	Lower (std UC) – f. dozer & r. stabilizer up													
	Lower (std UC) – f. dozer & r. stabilizer down													
	Lower (std UC) – 2 sets stabilizers up													
6000 mm	MH – stabilizers up – solid tires													
	MH – stabilizers down – solid tires													
	Lower (std UC) – f. stabilizer & r. dozer up													
	Lower (std UC) – f. stabilizer & r. dozer down													
	Lower (std UC) – f. dozer & r. stabilizer up													
	Lower (std UC) – f. dozer & r. stabilizer down													
	Lower (std UC) – 2 sets stabilizers up													
4500 mm	MH – stabilizers up – solid tires													
	MH – stabilizers down – solid tires													
	Lower (std UC) – f. stabilizer & r. dozer up													
	Lower (std UC) – f. stabilizer & r. dozer down													
	Lower (std UC) – f. dozer & r. stabilizer up													
	Lower (std UC) – f. dozer & r. stabilizer down													
	Lower (std UC) – 2 sets stabilizers up													
3000 mm	MH – stabilizers up – solid tires													
	MH – stabilizers down – solid tires													
	Lower (std UC) – f. stabilizer & r. dozer up													
	Lower (std UC) – f. stabilizer & r. dozer down													
	Lower (std UC) – f. dozer & r. stabilizer up													
	Lower (std UC) – f. dozer & r. stabilizer down													
	Lower (std UC) – 2 sets stabilizers up													
1500 mm	MH – stabilizers up – solid tires													
	MH – stabilizers down – solid tires													
	Lower (std UC) – f. stabilizer & r. dozer up													
	Lower (std UC) – f. stabilizer & r. dozer down													
	Lower (std UC) – f. dozer & r. stabilizer up													
	Lower (std UC) – f. dozer & r. stabilizer down													
	Lower (std UC) – 2 sets stabilizers up													
0 mm	MH – stabilizers up – solid tires													
	MH – stabilizers down – solid tires													
	Lower (std UC) – f. stabilizer & r. dozer up													
	Lower (std UC) – f. stabilizer & r. dozer down													
	Lower (std UC) – f. dozer & r. stabilizer up													
	Lower (std UC) – f. dozer & r. stabilizer down													
	Lower (std UC) – 2 sets stabilizers up													
-1500 mm	MH – stabilizers up – solid tires													
	MH – stabilizers down – solid tires													
	Lower (std UC) – f. stabilizer & r. dozer up													
	Lower (std UC) – f. stabilizer & r. dozer down													
	Lower (std UC) – f. dozer & r. stabilizer up													
	Lower (std UC) – f. dozer & r. stabilizer down													
	Lower (std UC) – 2 sets stabilizers up													
-3000 mm	MH – stabilizers up – solid tires													
	MH – stabilizers down – solid tires													
	Lower (std UC) – f. stabilizer & r. dozer up													
	Lower (std UC) – f. stabilizer & r. dozer down													
	Lower (std UC) – f. dozer & r. stabilizer up													
	Lower (std UC) – f. dozer & r. stabilizer down													
	Lower (std UC) – 2 sets stabilizers up													

*Limited by hydraulic rather than tipping load.

Lift capacity ratings are based on ISO 10567:2007, they do not exceed 87% of hydraulic lifting capacity or 75% of tipping load. The load point is the center line of the bucket pivot mounting pin on the stick. The oscillating axle must be locked. Lifting capacities are based on the machine standing on a firm uniform supporting surface. For lifting capacity including bucket and/or quick coupler, the respective weight has to be subtracted from above values. The use of a work tool attachment point to handle/lift objects, could affect the machine lift performance.

Always refer to the appropriate Operation and Maintenance Manual for specific product information.

Lifting Capacities ● MH3024 (Grenoble Sourced)

Material Handlers

Lift Capacities

All values are in lb, bucket cylinder and linkage installed, hydraulic cab riser, work tool: none, with counterweight (9040 lb), heavy lift on.

 Load point height

 Load over front

 Load over rear

 Load over side













 Load at maximum reach (sticknose/bucket pin)

Undercarriage

Boom One-Piece

Stick 8'2"

MH or Standard

Stick ft	Undercarriage configuration	10 ft			15 ft			20 ft			25 ft			ft						
																				
25 ft	MH – stabilizers up – solid tires													*8400	*8400	*8400				
	MH – stabilizers down – solid tires													*8400	*8400	*8400				
	Lower (std UC) – f. stabilizer & r. dozer up													*8400	*8400	*8400				
	Lower (std UC) – f. stabilizer & r. dozer down													*8400	*8400	*8400				
	Lower (std UC) – f. dozer & r. stabilizer up													*8400	*8400	*8400				
	Lower (std UC) – f. dozer & r. stabilizer down													*8400	*8400	*8400				
	Lower (std UC) – 2 sets stabilizers up													*8400	*8400	*8400				
20 ft	MH – stabilizers up – solid tires							12,800	12,800	9600				*7400	*7400	7300				
	MH – stabilizers down – solid tires							*14,100	*14,100	*14,100				*7400	*7400	*7400				
	Lower (std UC) – f. stabilizer & r. dozer up							12,500	11,900	9200				*7400	*7400	6900				
	Lower (std UC) – f. stabilizer & r. dozer down							*14,100	*14,100	14,000				*7400	*7400	*7400				
	Lower (std UC) – f. dozer & r. stabilizer up							13,000	11,500	9200				*7400	*7400	6900				
	Lower (std UC) – f. dozer & r. stabilizer down							*14,100	*14,100	*14,100				*7400	*7400	*7400				
	Lower (std UC) – 2 sets stabilizers up							12,900	11,800	9300				*7400	*7400	7000				
15 ft	MH – stabilizers up – solid tires							*14,100	*14,100	*14,100				*7400	*7400	*7400				
	MH – stabilizers down – solid tires							12,500	12,500	9300	8700	8700	6500	*7100	*7100	6000				
	Lower (std UC) – f. stabilizer & r. dozer up							12,200	11,600	8800	8500	8100	6100	*7100	*7100	5700				
	Lower (std UC) – f. stabilizer & r. dozer down							*15,100	*15,100	13,700	*12,100	*12,100	9500	*7100	*7100	*7100				
	Lower (std UC) – f. dozer & r. stabilizer up							12,600	11,100	8800	8800	7800	6100	*7100	*7100	5700				
	Lower (std UC) – f. dozer & r. stabilizer down							*15,100	*15,100	14,100	*12,100	*12,100	9800	*7100	*7100	*7100				
	Lower (std UC) – 2 sets stabilizers up							12,500	11,500	8900	8700	8000	6200	*7100	*7100	5800				
10 ft	MH – stabilizers up – solid tires							*15,100	*15,100	*15,100	*12,100	*12,100	11,700	*7100	*7100	*7100				
	MH – stabilizers down – solid tires							18,200	18,200	13,100	11,900	11,900	8500	6300	*7100	5400				
	Lower (std UC) – f. stabilizer & r. dozer up							*22,400	*22,400	*22,400	*16,700	*16,700	*16,700	*14,000	13,700	*7100	*7100			
	Lower (std UC) – f. stabilizer & r. dozer down							18,000	16,700	12,500	11,600	11,000	8300	7900	5900	*7100	6900	5100		
	Lower (std UC) – f. dozer & r. stabilizer up							*22,400	*22,400	20,300	*16,700	*16,700	13,100	*14,000	*14,000	9300	*7100	*7100		
	Lower (std UC) – f. dozer & r. stabilizer down							18,600	16,200	12,500	12,100	10,600	8300	8600	7600	5900	*7100	6600	5100	
	Lower (std UC) – 2 sets stabilizers up							*22,400	*22,400	21,000	*16,700	*16,700	13,500	*14,000	13,800	9600	*7100	*7100		
5 ft	Lower (std UC) – 2 sets stabilizers down							18,500	16,700	12,600	12,000	11,000	8400	8500	7800	6000	*7100	6800	5200	
	MH – stabilizers up – solid tires							*22,400	*22,400	*22,400	*16,700	*16,700	16,200	*14,000	*14,000	11,400	*7100	*7100		
	MH – stabilizers down – solid tires							17,100	17,100	12,100	11,400	11,400	8300	8300	6300	7200	5200			
	Lower (std UC) – f. stabilizer & r. dozer up							*25,400	*25,400	*25,400	*18,200	*18,200	*14,500	*14,500	13,400	*7400	*7400	*7400		
	Lower (std UC) – f. stabilizer & r. dozer down							16,800	15,700	11,500	11,100	10,500	7800	8000	7600	5700	7000	6600	4900	
	Lower (std UC) – f. dozer & r. stabilizer up							*25,400	*25,400	19,200	*18,200	*18,200	12,600	*14,500	13,000	9100	*7400	*7400	*7400	
	Lower (std UC) – f. dozer & r. stabilizer down							17,400	15,100	11,500	11,500	10,100	7800	8400	7300	5700	7200	6400	4900	
0 ft	Lower (std UC) – 2 sets stabilizers up							*25,400	*25,400	19,900	*18,200	*18,200	12,900	*14,500	13,600	9300	*7400	*7400	*7400	
	MH – stabilizers up – solid tires							16,800	16,600	11,600	11,000	11,000	7900	8100	8100	5900	7400	7400	5300	
	MH – stabilizers down – solid tires							*25,700	*25,700	*25,700	*18,700	*18,700	18,500	*14,400	*14,400	13,200	*8100	*8100	*8100	
	Lower (std UC) – f. stabilizer & r. dozer up							16,300	15,200	11,000	10,700	10,100	7500	7900	7500	5500	7100	6800	5000	
	Lower (std UC) – f. stabilizer & r. dozer down							*25,700	*25,700	18,600	*18,700	*18,700	12,200	*14,400	*14,400	8900	*8100	*8100	8100	
	Lower (std UC) – f. dozer & r. stabilizer up							16,900	14,600	11,000	11,200	9700	7500	8200	7200	5500	7400	6500	5000	
	Lower (std UC) – f. dozer & r. stabilizer down							*25,700	*25,700	19,300	*18,700	*18,700	12,600	*14,400	13,400	9100	*8100	*8100	*8100	
-5 ft	Lower (std UC) – 2 sets stabilizers up							16,800	15,100	11,200	11,100	10,100	7600	8100	7400	5600	7400	6700	5100	
	MH – stabilizers up – solid tires							*22,200	*22,200	*22,200	*17,700	*17,700	17,300	*11,300	*11,300	11,000	*9500	*9500	*9500	
	MH – stabilizers down – solid tires							21,500	16,500	16,500	11,600	10,900	8700	8100	8100	5900	8000	8000	5800	
	Lower (std UC) – f. stabilizer & r. dozer up							*22,200	*22,200	*23,800	*23,800	*17,700	*17,700	*11,300	*11,300	11,300	*9500	*9500	*9500	
	Lower (std UC) – f. stabilizer & r. dozer down							20,400	16,200	15,100	11,000	10,600	7400	7800	7500	5500	7800	7400	5500	
	Lower (std UC) – f. dozer & r. stabilizer up							*22,200	*22,200	*23,800	*23,800	18,600	*17,700	12,100	*11,300	*11,300	8900	*9500	*9500	8800
	Lower (std UC) – f. dozer & r. stabilizer down							20,400	16,900	14,500	11,000	11,000	9600	7400	8200	7100	5500	8100	7100	5500
-10 ft	Lower (std UC) – 2 sets stabilizers up							*22,200	*22,200	*23,800	*23,800	19,200	*17,700	12,400	*11,300	*11,300	9100	*9500	*9500	9100
	MH – stabilizers up – solid tires							*25,700	*25,700	21,900	16,700	16,700	11,800	11,000	7900		9700	9700	7000	
	MH – stabilizers down – solid tires							*25,700	*25,700	*25,700	*19,800	*19,800	*14,500	*14,500	*14,500		*11,800	*11,800	*11,800	
	Lower (std UC) – f. stabilizer & r. dozer up							20,800	16,400	15,300	11,100	10,800	7500		9400	8900	6700			
	Lower (std UC) – f. stabilizer & r. dozer down							*25,700	*25,700	*19,800	*19,800	18,800	*14,500	*14,500	12,200		*11,800	*11,800	10,700	
	Lower (std UC) – f. dozer & r. stabilizer up							20,800	17,100	14,700	11,100	11,200	9800	7500		9800	8600	6700		
	Lower (std UC) – f. dozer & r. stabilizer down							*25,700	*25,700	*19,800	*19,800	19,400	*14,500	*14,500	12,600		*11,800	*11,800	11,000	

*Limited by hydraulic rather than tipping load.

Lift capacity ratings are based on ISO 10567:2007, they do not exceed 87% of hydraulic lifting capacity or 75% of tipping load. The load point is the center line of the bucket pivot mounting pin on the stick. The oscillating axle must be locked. Lifting capacities are based on the machine standing on a firm uniform supporting surface. For lifting capacity including bucket and/or quick coupler, the respective weight has to be subtracted from above values. The use of a work tool attachment point to handle/lift objects, could affect the machine lift performance.

Always refer to the appropriate Operation and Maintenance Manual for specific product information.

Lift Capacities

All values are in kg, bucket cylinder and linkage installed, hydraulic cab riser, work tool: none, with counterweight (5200 kg), heavy lift on.



Undercarriage

Boom

Stick

MH or Standard

One-Piece

2.5 m

Stick height	Undercarriage configuration	3000 mm			4500 mm			6000 mm			7500 mm			mm			
		Load point height	Load over front	Load over rear	Load point height	Load over front	Load over rear	Load point height	Load over front	Load over rear	Load point height	Load over front	Load over rear				
7500 mm	MH – stabilizers up – solid tires							*3950	*3950	*3950				*3750	*3750	*3750	
	MH – stabilizers down – solid tires							*3950	*3950	*3950				*3750	*3750	*3750	
	Lower (std UC) – f. stabilizer & r. dozer up							*3950	*3950	*3950				*3750	*3750	*3750	
	Lower (std UC) – f. stabilizer & r. dozer down							*3950	*3950	*3950				*3750	*3750	*3750	
	Lower (std UC) – f. dozer & r. stabilizer up							*3950	*3950	*3950				*3750	*3750	*3750	
	Lower (std UC) – f. dozer & r. stabilizer down							*3950	*3950	*3950				*3750	*3750	*3750	
	Lower (std UC) – 2 sets stabilizers up							*3950	*3950	*3950				*3750	*3750	*3750	
6000 mm	MH – stabilizers up – solid tires							*6400	*6400	*6400				*3350	*3350	*3350	
	MH – stabilizers down – solid tires							*6400	*6400	*6400				*3350	*3350	*3350	
	Lower (std UC) – f. stabilizer & r. dozer up							*6400	*6400	*6400				*3350	*3350	*3350	
	Lower (std UC) – f. stabilizer & r. dozer down							*6400	*6400	*6400				*3350	*3350	*3350	
	Lower (std UC) – f. dozer & r. stabilizer up							*6400	*6400	*6400				*3350	*3350	*3350	
	Lower (std UC) – f. dozer & r. stabilizer down							*6400	*6400	*6400				*3350	*3350	*3350	
	Lower (std UC) – 2 sets stabilizers up							*6400	*6400	*6400				*3350	*3350	*3350	
4500 mm	MH – stabilizers up – solid tires							*6400	*6400	*6400				*3200	*3200	*3150	
	MH – stabilizers down – solid tires							*6950	*6950	*6950				*6150	*6150	*6150	
	Lower (std UC) – f. stabilizer & r. dozer up							6400	6000	4700	4500	4250	3300	*3200	*3200	3000	
	Lower (std UC) – f. stabilizer & r. dozer down							*6950	*6950	*6950				*6150	5000	*3200	
	Lower (std UC) – f. dozer & r. stabilizer up							6550	5850	4700	4650	4100	3300	*3200	*3200	3000	
	Lower (std UC) – f. dozer & r. stabilizer down							*6950	*6950	*6950				*6150	5100	*3200	
	Lower (std UC) – 2 sets stabilizers up							6550	6000	4750	4600	4250	3350	*3200	*3200	3050	
3000 mm	MH – stabilizers up – solid tires				9450	9450	6900	6200	6200	4650	4500	4500	3350	*3200	*3200	2850	
	MH – stabilizers down – solid tires				*10 400	*10 400	*10 400	*7750	*7750	*7750				*6400	*6400	*3200	
	Lower (std UC) – f. stabilizer & r. dozer up				9400	8750	6650	6100	5750	4450	4400	4150	3200	*3200	*3200	2750	
	Lower (std UC) – f. stabilizer & r. dozer down				*10 400	*10 400	*10 400	*7750	*7750	6850	*6400	*6400	4900	*3200	*3200	3200	
	Lower (std UC) – f. dozer & r. stabilizer up				9700	8450	6650	6300	5600	4450	4550	4000	3200	*3200	*3200	2750	
	Lower (std UC) – f. dozer & r. stabilizer down				*10 400	*10 400	*10 400	*7750	*7750	7000	*6400	*6400	5000	*3200	*3200	3200	
	Lower (std UC) – 2 sets stabilizers up				9650	8700	6700	6250	5750	4500	4500	4150	3250	*3200	*3200	2750	
1500 mm	MH – stabilizers up – solid tires				*10 400	*10 400	*10 400	*7750	*7750	*7750				*6400	*6400	*3200	
	MH – stabilizers down – solid tires				8950	8950	6450	5950	5950	4400	4350	4350	3250	*3200	*3200	2750	
	Lower (std UC) – f. stabilizer & r. dozer up				*11 750	*11 750	*11 750	*8400	*8400	*8400				*6700	*6700	*3200	
	Lower (std UC) – f. stabilizer & r. dozer down				8850	8250	6150	5850	5550	4200	4250	4050	3100	*3200	*3200	2650	
	Lower (std UC) – f. dozer & r. stabilizer up				*11 750	*11 750	10 000	*8400	*8400	6550	*6700	*6700	4700	*3200	*3200	3200	
	Lower (std UC) – f. dozer & r. stabilizer down				9150	7950	6150	6050	5350	4200	4400	3900	3100	*3200	*3200	2650	
	Lower (std UC) – 2 sets stabilizers up				*11 750	*11 750	10 350	*8400	*8400	6750	*6700	*6700	4900	*3200	*3200	3200	
0 mm	MH – stabilizers up – solid tires				9100	8200	6250	6000	5500	4250	4400	4050	3150	*3200	*3200	2650	
	MH – stabilizers down – solid tires				*11 750	*11 750	*11 750	*8400	*8400	8100	*6700	*6700	5800	*3200	*3200	3200	
	Lower (std UC) – f. stabilizer & r. dozer up				8750	8750	6250	5800	5800	4250	4300	4300	3150	*3700	*3700	2800	
	Lower (std UC) – f. stabilizer & r. dozer down				*11 850	*11 850	*11 850	*8600	*8600	*8600				*6650	*6650	*3700	
	Lower (std UC) – f. dozer & r. stabilizer up				8850	8000	5950	5700	5350	4050	4200	3950	3000	*3700	*3700	2700	
	Lower (std UC) – f. dozer & r. stabilizer down				*11 850	*11 850	9800	*8600	*8600	6400	*6650	*6650	4700	*3700	*3700	3700	
	Lower (std UC) – 2 sets stabilizers up				8950	7750	5950	5900	5200	4050	4300	3800	3000	*3700	*3700	2700	
-1500 mm	MH – stabilizers up – solid tires				*11 850	*11 850	*11 850	*8600	*8600	6600	*6650	*6650	4800	*3700	*3700	3700	
	MH – stabilizers down – solid tires				8900	8000	6050	5850	5350	4100	4300	3950	3050	*3700	*3700	2700	
	Lower (std UC) – f. stabilizer & r. dozer up				*11 850	*11 850	*11 850	*8600	*8600	7900	*6650	*6650	5700	*3700	*3700	3700	
	Lower (std UC) – f. stabilizer & r. dozer down				*9750	*9750	*9750	8700	8700	6200	5750	5750	4200	4250	3150	4150	3050
	Lower (std UC) – f. dozer & r. stabilizer up				*9750	*9750	*9750	8600	8000	5950	5650	5300	4000	4150	3950	3000	4050
	Lower (std UC) – f. dozer & r. stabilizer down				*9750	*9750	*9750	8800	7700	5950	5850	5100	4000	4300	3800	3000	4200
	Lower (std UC) – 2 sets stabilizers up				*9750	*9750	*9750	8900	7700	5950	5850	5100	4000	4300	3800	3000	4200
-3000 mm	MH – stabilizers up – solid tires				*9750	*9750	*9750	8850	7950	6000	5800	5300	4050	4300	3950	3050	4150
	MH – stabilizers down – solid tires				*9750	*9750	*9750	8850	7950	6000	5800	5300	4050	4300	3950	3050	4150
	Lower (std UC) – f. stabilizer & r. dozer up				*11 850	*11 850	*11 850	*9200	*9200	*9200				*6050	*6050	5700	
	Lower (std UC) – f. stabilizer & r. dozer down				*11 850	*11 850	*11 850	*9200	*9200	*9200				*6050	*6050	5700	
	Lower (std UC) – f. dozer & r. stabilizer up				*11 850	*11 850	*11 850	*9200	*9200	*9200				*6050	*6050	5700	
	Lower (std UC) – f. dozer & r. stabilizer down				*11 850	*11 850	*11 850	*9200	*9200	*9200				*6050	*6050	5700	
	Lower (std UC) – 2 sets stabilizers up				*11 850	*11 850	*11 850	*9200	*9200	*9200				*6050	*6050	5700	

* Limited by hydraulic rather than tipping load.

Lift capacity ratings are based on ISO 10567:2007, they do not exceed 87% of hydraulic lifting capacity or 75% of tipping load. The load point is the center line of the bucket pivot mounting pin on the stick. The oscillating axle must be locked. Lifting capacities are based on the machine standing on a firm uniform supporting surface. For lifting capacity including bucket and/or quick coupler, the respective weight has to be subtracted from above values. The use of a work tool attachment point to handle/lift objects, could affect the machine lift performance.

Always refer to the appropriate Operation and Maintenance Manual for specific product information.

Lifting Capacities • MH3024 (Grenoble Sourced)

Material Handlers

Lift Capacities

All values are in lb, bucket cylinder and linkage installed, hydraulic cab riser, work tool: none, with counterweight (11,470 lb), heavy lift on.

Load point height

Load over front

Load over rear

Load over side

Load at maximum reach (sticknose/bucket pin)

Undercarriage

Boom One-Piece

Stick 8'2"

MH or Standard

Stick 8'2"	Undercarriage configuration	10 ft			15 ft			20 ft			25 ft			ft				
25 ft	MH – stabilizers up – solid tires													*8400	*8400	*8400		
	MH – stabilizers down – solid tires													*8400	*8400	*8400		
	Lower (std UC) – f. stabilizer & r. dozer up													*8400	*8400	*8400		
	Lower (std UC) – f. stabilizer & r. dozer down													*8400	*8400	*8400		
	Lower (std UC) – f. dozer & r. stabilizer up													*8400	*8400	*8400		
	Lower (std UC) – f. dozer & r. stabilizer down													*8400	*8400	*8400		
	Lower (std UC) – 2 sets stabilizers up													*8400	*8400	*8400		
20 ft	MH – stabilizers up – solid tires							*14,100	*14,100	10,900				*7400	*7400	*7400		
	MH – stabilizers down – solid tires							*14,100	*14,100	*14,100				*7400	*7400	*7400		
	Lower (std UC) – f. stabilizer & r. dozer up							*14,100	13,300	10,400				*7400	*7400	*7400		
	Lower (std UC) – f. stabilizer & r. dozer down							*14,100	*14,100	*14,100				*7400	*7400	*7400		
	Lower (std UC) – f. dozer & r. stabilizer up							*14,100	12,900	10,400				*7400	*7400	*7400		
	Lower (std UC) – f. dozer & r. stabilizer down							*14,100	*14,100	*14,100				*7400	*7400	*7400		
	Lower (std UC) – 2 sets stabilizers up							*14,100	13,300	10,500				*7400	*7400	*7400		
15 ft	MH – stabilizers up – solid tires							13,900	13,900	10,500	9900	9900	7400	*7100	*7100	7000		
	MH – stabilizers down – solid tires							*15,100	*15,100	*15,100	*12,100	*12,100	*12,100	*7100	*7100	*7100		
	Lower (std UC) – f. stabilizer & r. dozer up							13,700	13,000	10,100	9600	9200	7100	*7100	*7100	6700		
	Lower (std UC) – f. stabilizer & r. dozer down							*15,100	*15,100	*15,100	*12,100	*12,100	10,800	*7100	*7100	*7100		
	Lower (std UC) – f. dozer & r. stabilizer up							14,200	12,600	10,100	10,000	8900	7100	*7100	*7100	6700		
	Lower (std UC) – f. dozer & r. stabilizer down							*15,100	*15,100	*15,100	*12,100	*12,100	11,000	*7100	*7100	*7100		
	Lower (std UC) – 2 sets stabilizers up							14,100	12,900	10,200	9900	9100	7200	*7100	*7100	6700		
10 ft	MH – stabilizers up – solid tires				20,400	20,400	14,900	13,400	13,400	10,000	9700	9700	7200	*7100	*7100	6300		
	MH – stabilizers down – solid tires				*22,400	*22,400	*22,400	*16,700	*16,700	*16,700	*14,000	*14,000	*14,000	*7100	*7100	*7100		
	Lower (std UC) – f. stabilizer & r. dozer up				20,300	18,800	14,300	13,200	12,400	9600	9400	9000	6900	*7100	*7100	6000		
	Lower (std UC) – f. stabilizer & r. dozer down				*22,400	*22,400	*22,400	*16,700	*16,700	14,700	*14,000	*14,000	10,500	*7100	*7100	*7100		
	Lower (std UC) – f. dozer & r. stabilizer up				20,900	18,300	14,300	13,600	12,000	9600	9800	8700	6700	*7100	*7100	6000		
	Lower (std UC) – f. dozer & r. stabilizer down				*22,400	*22,400	*22,400	*16,700	*16,700	15,100	*14,000	*14,000	10,800	*7100	*7100	*7100		
	Lower (std UC) – 2 sets stabilizers up				20,800	18,800	14,500	13,500	12,400	9700	8900	7900	6900	*7100	*7100	6100		
5 ft	MH – stabilizers up – solid tires				19,300	18,300	13,300	12,300	12,300	9500	9400	9400	7000	*7400	*7400	6100		
	MH – stabilizers down – solid tires				*25,400	*25,400	*25,400	*18,200	*18,200	*14,500	*14,500	*14,500	*14,500	*7400	*7400	*7400		
	Lower (std UC) – f. stabilizer & r. dozer up				19,100	17,800	13,300	12,600	11,900	9100	9200	8700	6700	*7400	*7400	5800		
	Lower (std UC) – f. stabilizer & r. dozer down				*25,400	*25,400	21,600	*18,200	*18,200	14,200	*14,500	10,300	*7400	*7400	*7400			
	Lower (std UC) – f. dozer & r. stabilizer up				19,700	17,200	13,300	13,100	11,500	9100	9500	8400	6700	*7400	*7400	5800		
	Lower (std UC) – f. dozer & r. stabilizer down				*25,400	*25,400	22,300	*18,200	*18,200	14,600	*14,500	10,500	*7400	*7400	*7400			
	Lower (std UC) – 2 sets stabilizers up				19,600	17,700	13,500	13,000	11,900	9200	9500	8700	6800	*7400	*7400	5900		
0 ft	MH – stabilizers up – solid tires				18,800	18,800	13,500	12,500	12,500	9200	9200	9200	6800	*8100	*8100	6200		
	MH – stabilizers down – solid tires				*25,700	*25,700	*25,700	*18,700	*18,700	*14,400	*14,400	*14,400	*14,400	*8100	*8100	*8100		
	Lower (std UC) – f. stabilizer & r. dozer up				18,600	17,300	12,900	12,300	11,600	8800	9000	8600	6500	*8100	*8100	5900		
	Lower (std UC) – f. stabilizer & r. dozer down				*25,700	*25,700	21,100	*18,700	*18,700	13,800	*14,400	*14,400	10,100	*8100	*8100	*8100		
	Lower (std UC) – f. dozer & r. stabilizer up				19,200	16,700	12,900	12,700	11,200	8800	9300	8200	6500	*8100	*8100	5900		
	Lower (std UC) – f. dozer & r. stabilizer down				*25,700	*25,700	21,800	*18,700	*18,700	14,200	*14,400	*14,400	10,400	*8100	*8100	*8100		
	Lower (std UC) – 2 sets stabilizers up				19,100	17,200	13,000	12,600	11,500	8900	9300	8500	6600	*8100	*8100	6000		
-5 ft	MH – stabilizers up – solid tires				*22,200	*22,200	*22,200	18,700	18,700	13,400	12,400	9100	9200	9200	6800	9200	6800	
	MH – stabilizers down – solid tires				*22,200	*22,200	*22,200	*23,800	*23,800	*17,700	*17,700	*11,300	*11,300	*11,300	*9500	*9500	*9500	
	Lower (std UC) – f. stabilizer & r. dozer up				*22,200	*22,200	*22,200	18,500	17,200	12,800	12,200	11,500	8700	9000	8500	8500	6500	
	Lower (std UC) – f. stabilizer & r. dozer down				*22,200	*22,200	*22,200	*23,800	*23,800	21,000	*17,700	*17,700	13,700	*11,300	*11,300	10,100	*9500	*9500
	Lower (std UC) – f. dozer & r. stabilizer up				*22,200	*22,200	*22,200	19,100	16,600	12,800	12,600	11,100	8700	9300	8200	6500	9300	6500
	Lower (std UC) – f. dozer & r. stabilizer down				*22,200	*22,200	*22,200	*23,800	*23,800	21,700	*17,700	*17,700	14,100	*11,300	*11,300	10,400	*9500	*9500
	Lower (std UC) – 2 sets stabilizers up				*22,200	*22,200	*22,200	19,000	17,100	12,900	12,500	11,400	8800	9300	8500	6600	9200	8400
-10 ft	MH – stabilizers up – solid tires				*25,700	*25,700	25,100	18,900	18,900	13,600	12,500	12,500	9200		11,000	11,000	8200	
	MH – stabilizers down – solid tires				*25,700	*25,700	*25,700	*19,800	*19,800	*19,800	*14,500	*14,500	*14,500		*11,800	*11,800	*11,800	
	Lower (std UC) – f. stabilizer & r. dozer up				*25,700	*25,700	24,000	18,700	17,400	13,000	12,300	11,600	8800		10,800	10,200	7800	
	Lower (std UC) – f. stabilizer & r. dozer down				*25,700	*25,700	*25,700	*19,800	*19,800	*19,800	*14,500	*14,500	13,800		*11,800	*11,800	*11,800	
	Lower (std UC) – f. dozer & r. stabilizer up				*25,700	*25,700	24,000	19,300	16,800	13,000	12,700	11,200	8800		11,200	9800	7800	
	Lower (std UC) – f. dozer & r. stabilizer down				*25,700	*25,700	*25,700	*19,800	*19,800	*19,800	*14,500	*14,500	14,200		*11,800	*11,800	*11,800	
	Lower (std UC) – 2 sets stabilizers up				*25,700	*25,700	24,300	19,200	17,300	13,100	12,600	11,500	8900		11,100	10,200	7900	

*Limited by hydraulic rather than tipping load.

Lift capacity ratings are based on ISO 10567:2007, they do not exceed 87% of hydraulic lifting capacity or 75% of tipping load. The load point is the center line of the bucket pivot mounting pin on the stick. The oscillating axle must be locked. Lifting capacities are based on the machine standing on a firm uniform supporting surface. For lifting capacity including bucket and/or quick coupler, the respective weight has to be subtracted from above values. The use of a work tool attachment point to handle/lift objects, could affect the machine lift performance.

Always refer to the appropriate Operation and Maintenance Manual for specific product information.

Lift Capacities

All values are in kg, bucket cylinder and linkage installed, hydraulic cab riser, work tool: none, with counterweight (4100 kg), heavy lift on.

		Load point height	Load over front	Load over rear	Load over side	Load at maximum reach (sticknose/bucket pin)										
Undercarriage		Boom						Stick								
MH or Standard		One-Piece						2.9 m								
	Undercarriage configuration	3000 mm			4500 mm			6000 mm			7500 mm				mm	
7500 mm	MH – stabilizers up – solid tires													*3050	*3050	*3050
	MH – stabilizers down – solid tires													*3050	*3050	*3050
	Lower (std UC) – f. stabilizer & r. dozer up													*3050	*3050	*3050
	Lower (std UC) – f. stabilizer & r. dozer down													*3050	*3050	*3050
	Lower (std UC) – f. dozer & r. stabilizer up													*3050	*3050	*3050
	Lower (std UC) – f. dozer & r. stabilizer down													*3050	*3050	*3050
	Lower (std UC) – 2 sets stabilizers up													*3050	*3050	*3050
6000 mm	MH – stabilizers up – solid tires													*3850	*3850	*3050
	MH – stabilizers down – solid tires													*3850	*3850	*2750
	Lower (std UC) – f. stabilizer & r. dozer up													*3850	3800	2900
	Lower (std UC) – f. stabilizer & r. dozer down													*3850	*3850	2900
	Lower (std UC) – f. dozer & r. stabilizer up													*3850	3700	2900
	Lower (std UC) – f. dozer & r. stabilizer down													*3850	*3850	*3850
	Lower (std UC) – 2 sets stabilizers up													*3850	3800	2950
4500 mm	MH – stabilizers up – solid tires													*5800	5800	4350
	MH – stabilizers down – solid tires													*6550	*6550	*6550
	Lower (std UC) – f. stabilizer & r. dozer up													5700	5400	4150
	Lower (std UC) – f. stabilizer & r. dozer down													*6550	*6550	6400
	Lower (std UC) – f. dozer & r. stabilizer up													5900	5200	4150
	Lower (std UC) – f. dozer & r. stabilizer down													*6550	*6550	*6550
	Lower (std UC) – 2 sets stabilizers up													5850	5350	4200
3000 mm	MH – stabilizers up – solid tires													*6550	*6550	*6550
	MH – stabilizers down – solid tires													*5850	*5850	*5850
	Lower (std UC) – f. stabilizer & r. dozer up													8550	8550	6150
	Lower (std UC) – f. stabilizer & r. dozer down													*9850	*9850	*9850
	Lower (std UC) – f. dozer & r. stabilizer up													8450	7850	5850
	Lower (std UC) – f. dozer & r. stabilizer down													*9850	*9850	9550
	Lower (std UC) – 2 sets stabilizers up													8750	7600	5600
1500 mm	MH – stabilizers up – solid tires													*9850	*9850	*9850
	MH – stabilizers down – solid tires													*8000	8000	5300
	Lower (std UC) – f. stabilizer & r. dozer up													*11400	*11400	*11400
	Lower (std UC) – f. stabilizer & r. dozer down													7850	7300	5350
	Lower (std UC) – f. dozer & r. stabilizer up													*11400	*11400	8950
	Lower (std UC) – f. dozer & r. stabilizer down													8150	7050	5350
	Lower (std UC) – 2 sets stabilizers up													*11400	*11400	9300
0 mm	MH – stabilizers up – solid tires													8100	7250	5400
	MH – stabilizers down – solid tires													*11400	*11400	*11400
	Lower (std UC) – f. stabilizer & r. dozer up													7700	7700	5350
	Lower (std UC) – f. stabilizer & r. dozer down													*11850	*11850	*11850
	Lower (std UC) – f. dozer & r. stabilizer up													7550	7000	5100
	Lower (std UC) – f. dozer & r. stabilizer down													*11850	*11850	8650
	Lower (std UC) – 2 sets stabilizers up													7850	6750	5100
-1500 mm	MH – stabilizers up – solid tires													*11850	*11850	*11850
	MH – stabilizers down – solid tires													*9250	*9250	*9250
	Lower (std UC) – f. stabilizer & r. dozer up													*11250	*11250	*11250
	Lower (std UC) – f. stabilizer & r. dozer down													*9250	*9250	7450
	Lower (std UC) – f. dozer & r. stabilizer up													*9250	*9250	7750
	Lower (std UC) – f. dozer & r. stabilizer down													*9250	*9250	7750
	Lower (std UC) – 2 sets stabilizers up													*9250	*9250	7700
-3000 mm	MH – stabilizers up – solid tires													*13200	*13200	*13200
	MH – stabilizers down – solid tires													*13200	*13200	*13200
	Lower (std UC) – f. stabilizer & r. dozer up													*13200	*13200	9500
	Lower (std UC) – f. stabilizer & r. dozer down													*13200	*13200	9750
	Lower (std UC) – f. dozer & r. stabilizer up													*13200	*13200	9500
	Lower (std UC) – f. dozer & r. stabilizer down													*13200	*13200	9750
	Lower (std UC) – 2 sets stabilizers up													*13200	*13200	9600

*Limited by hydraulic rather than tipping load.

Lift capacity ratings are based on ISO 10567:2007, they do not exceed 87% of hydraulic lifting capacity or 75% of tipping load. The load point is the center line of the bucket pivot mounting pin on the stick. The oscillating axle must be locked. Lifting capacities are based on the machine standing on a firm uniform supporting surface. For lifting capacity including bucket and/or quick coupler, the respective weight has to be subtracted from above values. The use of a work tool attachment point to handle/lift objects, could affect the machine lift performance.

Always refer to the appropriate Operation and Maintenance Manual for specific product information.

Lift Capacities

All values are in lb, bucket cylinder and linkage installed, hydraulic cab riser, work tool: none, with counterweight (9040 lb), heavy lift on.

		Load point height			Load over front			Load over rear			Load over side			Load at maximum reach (sticknose/bucket pin)						
Undercarriage		Boom									Stick									
MH or Standard		10 ft			15 ft			20 ft			25 ft					ft				
Undercarriage configuration																		ft		
25 ft	MH – stabilizers up – solid tires																*6900	*6900	*6900	
	MH – stabilizers down – solid tires																	*6900	*6900	*6900
	Lower (std UC) – f. stabilizer & r. dozer up																	*6900	*6900	*6900
	Lower (std UC) – f. stabilizer & r. dozer down																	*6900	*6900	*6900
	Lower (std UC) – f. dozer & r. stabilizer up																	*6900	*6900	*6900
	Lower (std UC) – f. dozer & r. stabilizer down																	*6900	*6900	*6900
20 ft	MH – stabilizers up – solid tires																	*6100	*6100	*6100
	MH – stabilizers down – solid tires																	*6100	*6100	*6100
	Lower (std UC) – f. stabilizer & r. dozer up																	*6100	*6100	*6100
	Lower (std UC) – f. stabilizer & r. dozer down																	*6100	*6100	*6100
	Lower (std UC) – f. dozer & r. stabilizer up																	*6100	*6100	*6100
	Lower (std UC) – f. dozer & r. stabilizer down																	*6100	*6100	*6100
15 ft	MH – stabilizers up – solid tires																	*5900	*5900	*5500
	MH – stabilizers down – solid tires																	*5900	*5900	*5900
	Lower (std UC) – f. stabilizer & r. dozer up																	*5900	*5900	*5200
	Lower (std UC) – f. stabilizer & r. dozer down																	*5900	*5900	*5900
	Lower (std UC) – f. dozer & r. stabilizer up																	*5900	*5900	*5200
	Lower (std UC) – f. dozer & r. stabilizer down																	*5900	*5900	*5900
10 ft	MH – stabilizers up – solid tires																	*5900	*5900	*5000
	MH – stabilizers down – solid tires																	*5900	*5900	*5900
	Lower (std UC) – f. stabilizer & r. dozer up																	*5900	*5900	*4700
	Lower (std UC) – f. stabilizer & r. dozer down																	*5900	*5900	*5900
	Lower (std UC) – f. dozer & r. stabilizer up																	*5900	*5900	*4700
	Lower (std UC) – f. dozer & r. stabilizer down																	*5900	*5900	*5900
5 ft	MH – stabilizers up – solid tires																	*6100	*6100	*4800
	MH – stabilizers down – solid tires																	*6100	*6100	*6100
	Lower (std UC) – f. stabilizer & r. dozer up																	*6100	*6100	*4500
	Lower (std UC) – f. stabilizer & r. dozer down																	*6100	*6100	*6100
	Lower (std UC) – f. dozer & r. stabilizer up																	*6100	*6100	*4500
	Lower (std UC) – f. dozer & r. stabilizer down																	*6100	*6100	*6100
0 ft	MH – stabilizers up – solid tires																	*6700	*6700	*4900
	MH – stabilizers down – solid tires																	*6700	*6700	*6700
	Lower (std UC) – f. stabilizer & r. dozer up																	*6700	*6700	*4600
	Lower (std UC) – f. stabilizer & r. dozer down																	*6700	*6700	*6700
	Lower (std UC) – f. dozer & r. stabilizer up																	*6700	*6700	*4600
	Lower (std UC) – f. dozer & r. stabilizer down																	*6700	*6700	*6700
-5 ft	MH – stabilizers up – solid tires	*21,000	*21,000	*21,000	16,400	16,400	11,400	10,800	10,800	7700	7900	7900	5700	7400	7400	5300				
	MH – stabilizers down – solid tires	*21,000	*21,000	*21,000	*24,400	*24,400	*24,400	*18,000	*18,000	*18,000	*13,500	*13,500	13,100	*7700	*7700	*7700				
	Lower (std UC) – f. stabilizer & r. dozer up	*21,000	*21,000	20,000	16,100	14,900	10,800	10,500	9900	7300	7700	7300	5400	7100	6800	5000				
	Lower (std UC) – f. stabilizer & r. dozer down	*21,000	*21,000	*21,000	*24,400	*24,400	18,400	*18,000	*18,000	12,000	*13,500	8700	7700	*7700	*7700	*7700				
	Lower (std UC) – f. dozer & r. stabilizer up	*21,000	*21,000	20,000	16,700	14,300	10,800	10,900	9500	7300	8000	7000	5400	7400	6500	5000				
	Lower (std UC) – f. dozer & r. stabilizer down	*21,000	*21,000	*21,000	*24,400	*24,400	19,100	*18,000	*18,000	12,300	*13,500	13,200	9000	*7700	*7700	*7700				
-10 ft	Lower (std UC) – 2 sets stabilizers up	*21,000	*21,000	20,300	16,600	14,800	10,900	10,800	9800	7400	8000	7300	5500	7400	6700	5100				
	Lower (std UC) – 2 sets stabilizers down	*21,000	*21,000	*21,000	*24,400	*24,400	23,700	*18,000	*18,000	15,000	*13,500	13,500	10,800	*7700	*7700	*7700				
	MH – stabilizers up – solid tires	*28,600	*28,600	21,500	16,500	16,500	11,500	10,800	10,800	7700				8700	8700	6300				
	MH – stabilizers down – solid tires	*28,600	*28,600	*28,600	*21,100	*21,100	*21,100	*15,600	*15,600	*15,600				*9700	*9700	*9700				
	Lower (std UC) – f. stabilizer & r. dozer up	*28,600	*28,600	20,400	16,200	15,100	10,900	10,600	10,000	7300				8400	8000	5900				
	Lower (std UC) – f. stabilizer & r. dozer down	*28,600	*28,600	*28,600	*21,100	*21,100	18,500	*15,600	*15,600	12,000				*9700	*9700	9600				
-15 ft	Lower (std UC) – f. dozer & r. stabilizer up	*28,600	28,300	20,400	16,800	14,500	10,900	11,000	9600	7300				8800	7700	5900				
	Lower (std UC) – f. dozer & r. stabilizer down	*28,600	*28,600	*28,600	*21,100	*21,100	19,200	*15,600	*15,600	12,400				*9700	*9700	*9700				
	Lower (std UC) – 2 sets stabilizers up	*28,600	*28,600	20,600	16,700	15,000	11,100	10,900	9900	7400				8700	8000	6000				
	Lower (std UC) – 2 sets stabilizers down	*28,600	*28,600	*28,600	*21,100	*21,100	*21,100	*15,600	*15,600	15,000				*9700	*9700	*9700				
	MH – stabilizers up – solid tires																			
	MH – stabilizers down – solid tires																			

9

*Limited by hydraulic rather than tipping load.

Lift capacity ratings are based on ISO 10567:2007, they do not exceed 87% of hydraulic lifting capacity or 75% of tipping load. The load point is the center line of the bucket pivot mounting pin on the stick. The oscillating axle must be locked. Lifting capacities are based on the machine standing on a firm uniform supporting surface. For lifting capacity including bucket and/or quick coupler, the respective weight has to be subtracted from above values. The use of a work tool attachment point to handle/lift objects, could affect the machine lift performance.

Always refer to the appropriate Operation and Maintenance Manual for specific product information.

Lift Capacities

All values are in kg, bucket cylinder and linkage installed, hydraulic cab riser, work tool: none, with counterweight (5200 kg), heavy lift on.

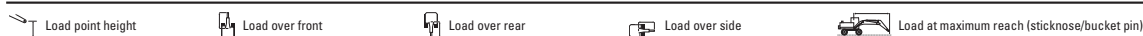

Undercarriage		Boom						Stick						
MH or Standard		3000 mm		4500 mm		6000 mm		7500 mm		7500 mm		7500 mm		mm
Stick height	Undercarriage configuration	Load over front		Load over rear		Load over side		Load over side		Load at maximum reach		Load at maximum reach		mm
		mm	mm	mm	mm	mm	mm	mm	mm	mm	mm	mm	mm	
7500 mm	MH – stabilizers up – solid tires													
	MH – stabilizers down – solid tires													
	Lower (std UC) – f. stabilizer & r. dozer up													
	Lower (std UC) – f. stabilizer & r. dozer down													
6000 mm	Lower (std UC) – f. dozer & r. stabilizer up													
	Lower (std UC) – f. dozer & r. stabilizer down													
	Lower (std UC) – 2 sets stabilizers up													
	Lower (std UC) – 2 sets stabilizers down													
4500 mm	MH – stabilizers up – solid tires													
	MH – stabilizers down – solid tires													
	Lower (std UC) – f. stabilizer & r. dozer up													
	Lower (std UC) – f. stabilizer & r. dozer down													
3000 mm	Lower (std UC) – f. dozer & r. stabilizer up													
	Lower (std UC) – f. dozer & r. stabilizer down													
	Lower (std UC) – 2 sets stabilizers up													
	Lower (std UC) – 2 sets stabilizers down													
1500 mm	MH – stabilizers up – solid tires													
	MH – stabilizers down – solid tires													
	Lower (std UC) – f. stabilizer & r. dozer up													
	Lower (std UC) – f. stabilizer & r. dozer down													
0 mm	Lower (std UC) – f. dozer & r. stabilizer up													
	Lower (std UC) – f. dozer & r. stabilizer down													
	Lower (std UC) – 2 sets stabilizers up													
	Lower (std UC) – 2 sets stabilizers down													
-1500 mm	MH – stabilizers up – solid tires													
	MH – stabilizers down – solid tires													
	Lower (std UC) – f. stabilizer & r. dozer up													
	Lower (std UC) – f. stabilizer & r. dozer down													
-3000 mm	Lower (std UC) – f. dozer & r. stabilizer up													
	Lower (std UC) – f. dozer & r. stabilizer down													
	Lower (std UC) – 2 sets stabilizers up													
	Lower (std UC) – 2 sets stabilizers down													
-4500 mm	MH – stabilizers up – solid tires													
	MH – stabilizers down – solid tires													
	Lower (std UC) – f. stabilizer & r. dozer up													
	Lower (std UC) – f. stabilizer & r. dozer down													

*Limited by hydraulic rather than tipping load.

Lift capacity ratings are based on ISO 10567:2007, they do not exceed 87% of hydraulic lifting capacity or 75% of tipping load. The load point is the center line of the bucket pivot mounting pin on the stick. The oscillating axle must be locked. Lifting capacities are based on the machine standing on a firm uniform supporting surface. For lifting capacity including bucket and/or quick coupler, the respective weight has to be subtracted from above values. The use of a work tool attachment point to handle/lift objects, could affect the machine lift performance.

Always refer to the appropriate Operation and Maintenance Manual for specific product information.

Lifting Capacities ● MH3024 (Grenoble Sourced)

Material Handlers

Lift Capacities

All values are in lb, bucket cylinder and linkage installed, hydraulic cab riser, work tool: none, with counterweight (11,470 lb), heavy lift on.

Lift point height	Load over front	Load over rear	Load over side	Load at maximum reach (sticknose/bucket pin)	Undercarriage			Boom			Stick			ft		
					MH or Standard			One-Piece			9'6"					
	10 ft			15 ft			20 ft			25 ft						
Undercarriage configuration																
25 ft	MH – stabilizers up – solid tires													*6900	*6900	*6900
	MH – stabilizers down – solid tires													*6900	*6900	*6900
	Lower (std UC) – f. stabilizer & r. dozer up													*6900	*6900	*6900
	Lower (std UC) – f. stabilizer & r. dozer down													*6900	*6900	*6900
	Lower (std UC) – f. dozer & r. stabilizer up													*6900	*6900	*6900
	Lower (std UC) – 2 sets stabilizers down														*6900	*6900
20 ft	MH – stabilizers up – solid tires													*6100	*6100	*6100
	MH – stabilizers down – solid tires													*6100	*6100	*6100
	Lower (std UC) – f. stabilizer & r. dozer up													*6100	*6100	*6100
	Lower (std UC) – f. stabilizer & r. dozer down													*6100	*6100	*6100
	Lower (std UC) – f. dozer & r. stabilizer up													*6100	*6100	*6100
	Lower (std UC) – 2 sets stabilizers down														*6100	*6100
15 ft	MH – stabilizers up – solid tires							14,000	14,000	10,600	9900	9900	7500	*5900	*5900	*5900
	MH – stabilizers down – solid tires							*14,300	*14,300	*14,300	*12,800	*12,800	*12,800	*5900	*5900	*5900
	Lower (std UC) – f. stabilizer & r. dozer up							13,800	13,100	10,200	9700	9200	7100	*5900	*5900	*5900
	Lower (std UC) – f. stabilizer & r. dozer down							*14,300	*14,300	*14,300	*12,800	*12,800	10,800	*5900	*5900	*5900
	Lower (std UC) – f. dozer & r. stabilizer up							14,200	12,700	10,200	10,000	8900	7100	*5900	*5900	*5900
	Lower (std UC) – 2 sets stabilizers down							*14,300	*14,300	*14,300	*12,800	*12,800	11,100	*5900	*5900	*5900
10 ft	MH – stabilizers up – solid tires				20,600	20,600	15,100	13,500	10,100	9700	9700	7200	*5900	*5900	*5900	5900
	MH – stabilizers down – solid tires				*21,200	*21,200	*21,200	*16,000	*16,000	*16,000	*13,500	*13,500	*13,500	*5900	*5900	*5900
	Lower (std UC) – f. stabilizer & r. dozer up				20,500	18,100	14,500	12,200	12,500	9700	9400	9000	6900	*5900	*5900	5600
	Lower (std UC) – f. stabilizer & r. dozer down				*21,200	*21,200	*21,200	*16,000	*16,000	*14,800	*13,500	*13,500	10,500	*5900	*5900	*5900
	Lower (std UC) – f. dozer & r. stabilizer up				21,100	18,500	14,500	13,700	12,100	9700	9800	8700	6900	*5900	*5900	5600
	Lower (std UC) – 2 sets stabilizers down				*21,200	*21,200	*21,200	*16,000	*16,000	*15,200	*13,500	*13,500	10,800	*5900	*5900	*5900
5 ft	MH – stabilizers up – solid tires				19,400	19,400	14,000	12,900	12,900	9500	9400	9400	7000	*6100	*6100	5600
	MH – stabilizers down – solid tires				*24,600	*24,600	*24,600	*17,700	*17,700	*17,700	*14,200	*14,200	*14,200	*6100	*6100	*6100
	Lower (std UC) – f. stabilizer & r. dozer up				19,200	17,900	13,400	12,600	11,900	9100	9200	8700	6600	*6100	*6100	5400
	Lower (std UC) – f. stabilizer & r. dozer down				*24,600	*24,600	*21,700	*17,700	*17,700	*14,200	*14,200	*14,200	10,300	*6100	*6100	*6100
	Lower (std UC) – f. dozer & r. stabilizer up				19,800	17,300	13,400	13,100	11,500	9100	9500	8400	6600	*6100	*6100	5400
	Lower (std UC) – 2 sets stabilizers down				*24,600	*24,600	*22,400	*17,700	*17,700	14,600	*14,200	*14,200	10,500	*6100	*6100	*6100
0 ft	MH – stabilizers up – solid tires				18,700	18,700	13,400	12,500	12,500	9100	9100	6800	*6700	*6700	5700	
	MH – stabilizers down – solid tires				*25,700	*25,700	*25,700	*18,500	*18,500	*18,500	*14,400	*14,400	*14,400	*6700	*6700	*6700
	Lower (std UC) – f. stabilizer & r. dozer up				18,500	17,200	12,800	12,200	11,500	8700	8900	8500	6400	*6700	*6700	5500
	Lower (std UC) – f. stabilizer & r. dozer down				*25,700	*25,700	21,000	*18,500	*18,500	13,700	*14,400	*14,400	10,000	*6700	*6700	*6700
	Lower (std UC) – f. dozer & r. stabilizer up				19,200	16,600	12,900	12,600	11,100	8700	9200	8200	6400	*6700	*6700	5500
	Lower (std UC) – 2 sets stabilizers down				*25,700	*25,700	21,700	*18,500	*18,500	14,100	*14,400	*14,400	10,300	*6700	*6700	*6700
-5 ft	MH – stabilizers up – solid tires	*21,000	*21,000	*21,000	18,500	18,500	13,200	12,300	12,300	9000	9100	9100	6700	*7700	*7700	6200
	MH – stabilizers down – solid tires	*21,000	*21,000	*21,000	*24,400	*24,400	*24,400	*18,000	*18,000	*18,000	*13,500	*13,500	*13,500	*7700	*7700	*7700
	Lower (std UC) – f. stabilizer & r. dozer up	*21,000	*21,000	*21,000	18,300	17,000	12,600	12,000	11,300	8500	8900	8400	6400	*7700	*7700	5900
	Lower (std UC) – f. stabilizer & r. dozer down	*21,000	*21,000	*21,000	*24,400	*24,400	20,800	*18,000	*18,000	13,600	*13,500	*13,500	9900	*7700	*7700	*7700
	Lower (std UC) – f. dozer & r. stabilizer up	*21,000	*21,000	*21,000	19,000	16,400	12,600	12,500	10,900	8500	9200	8100	6400	*7700	*7700	5900
	Lower (std UC) – 2 sets stabilizers down	*21,000	*21,000	*21,000	*24,400	*24,400	21,500	*18,000	*18,000	13,900	*13,500	*13,500	10,200	*7700	*7700	*7700
-10 ft	MH – stabilizers up – solid tires	*28,600	*28,600	*28,600	18,900	18,900	13,200	12,400	11,300	8600	9100	8300	6400	*9700	*9700	6000
	MH – stabilizers down – solid tires	*28,600	*28,600	*28,600	*24,400	*24,400	*24,400	*18,000	*18,000	16,200	*13,500	*13,500	12,200	*9700	*9700	*9700
	Lower (std UC) – f. stabilizer & r. dozer up	*28,600	*28,600	*28,600	21,100	21,100	*21,100	*15,600	*15,600	*15,600				*9700	*9700	*9700
	Lower (std UC) – f. stabilizer & r. dozer down	*28,600	*28,600	*28,600	*21,100	*21,100	20,900	*15,600	*15,600	13,600				*9700	*9700	*9700
	Lower (std UC) – f. dozer & r. stabilizer up	*28,600	*28,600	*28,600	19,100	16,600	12,700	12,500	11,000	8600				*9700	*9700	*9700
	Lower (std UC) – 2 sets stabilizers down	*28,600	*28,600	*28,600	*21,100	*21,100	*21,100	*15,600	*15,600	14,000				*9700	*9700	*9700
-15 ft	MH – stabilizers up – solid tires				14,500	14,500	13,800							*9700	*9700	*9700
	MH – stabilizers down – solid tires				*14,500	*14,500	*14,500									
	Lower (std UC) – f. stabilizer & r. dozer up				14,500	14,500	13,200									
	Lower (std UC) – f. stabilizer & r. dozer down				*14,500	*14,500	*14,500									
	Lower (std UC) – f. dozer & r. stabilizer up				14,500	14,500	13,200									
	Lower (std UC) – 2 sets stabilizers down				*14,500	*14,500	*14,500									

*Limited by hydraulic rather than tipping load.

Lift capacity ratings are based on ISO 10567:2007, they do not exceed 87% of hydraulic lifting capacity or 75% of tipping load. The load point is the center line of the bucket pivot mounting pin on the stick. The oscillating axle must be locked. Lifting capacities are based on the machine standing on a firm uniform supporting surface. For lifting capacity including bucket and/or quick coupler, the respective weight has to be subtracted from above values. The use of a work tool attachment point to handle/lift objects, could affect the machine lift performance.

Always refer to the appropriate Operation and Maintenance Manual for specific product information.

Lift Capacities

All values are in kg, bucket cylinder and linkage installed, hydraulic cab riser, work tool: none, with counterweight (4100 kg), heavy lift on.

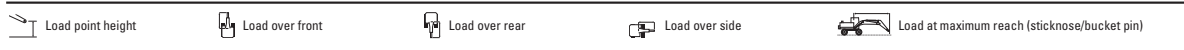

Undercarriage

Boom

Stick

MH or Standard

VA

2.5 m

Undercarriage configuration	3000 mm			4500 mm			6000 mm			7500 mm			mm	
7500 mm	MH – stabilizers up – solid tires MH – stabilizers down – solid tires Lower (std UC) – f. stabilizer & r. dozer up Lower (std UC) – f. stabilizer & r. dozer down Lower (std UC) – f. dozer & r. stabilizer up Lower (std UC) – f. dozer & r. stabilizer down Lower (std UC) – 2 sets stabilizers up Lower (std UC) – 2 sets stabilizers down												*3850 *3850	5870
6000 mm	MH – stabilizers up – solid tires MH – stabilizers down – solid tires Lower (std UC) – f. stabilizer & r. dozer up Lower (std UC) – f. stabilizer & r. dozer down Lower (std UC) – f. dozer & r. stabilizer up Lower (std UC) – f. dozer & r. stabilizer down Lower (std UC) – 2 sets stabilizers up Lower (std UC) – 2 sets stabilizers down						6000 *6750 6000 *6750 4450 *6750	6000 *6750 5900 *6750 6600 *6750	6000 *6750 5900 *6750 6600 *6750				*3350 *3350	7080
4500 mm	MH – stabilizers up – solid tires MH – stabilizers down – solid tires Lower (std UC) – f. stabilizer & r. dozer up Lower (std UC) – f. stabilizer & r. dozer down Lower (std UC) – f. dozer & r. stabilizer up Lower (std UC) – f. dozer & r. stabilizer down Lower (std UC) – 2 sets stabilizers up Lower (std UC) – 2 sets stabilizers down			*8750 *8750 *8750 *8750 *8750 *8750 *8750 *8750 *8750 *8750 *8750 *8750	*8750 *8750 8450 *8750 8450 *8750 8200 *8750 8200 *8750 8450 *8750 8450 *8750	6700 *7100 6400 *7100 6400 *7100 5900 *7100 5200 *7100 5850 *7100 6500 *7100	5800 *7100 5400 *7100 5400 *7100 5200 *7100 4100 *7100 5350 *7100 5350 *7100	4300 *5800 4100 *5800 4100 *5800 3600 *5800 2850 *5800 4050 *5800 4050 *5800	4050 *5800 3950 *5800 3950 *5800 3600 *5800 2850 *5800 4550 *5800 4550 *5800	3000 *5800 2850 *5800 2850 *5800 2850 *5800 2850 *5800 3150 *5800 3150 *5800	*3150 *3150	7810		
3000 mm	MH – stabilizers up – solid tires MH – stabilizers down – solid tires Lower (std UC) – f. stabilizer & r. dozer up Lower (std UC) – f. stabilizer & r. dozer down Lower (std UC) – f. dozer & r. stabilizer up Lower (std UC) – f. dozer & r. stabilizer down Lower (std UC) – 2 sets stabilizers up Lower (std UC) – 2 sets stabilizers down			8550 *10 500 8450 *10 500 8700 *10 500 8700 *10 500 8650 *10 500 *10 500 *10 500	8550 *10 500 7850 *10 500 7550 *10 500 5800 *10 500 7800 *10 500 *10 500 *10 500	6100 *7550 5800 *7550 5800 *7550 5650 *7550 5600 *7550 *7550 *7550	5550 *7550 5450 *7550 4950 *7550 4950 *7550 5100 *7550 *7550 *7550	4050 *6000 3850 *6000 3850 *6000 3850 *6000 3900 *6000 *6000 *6000	3950 *6000 3850 *6000 3850 *6000 3500 *6000 3950 *6000 *6000 *6000	2900 *6000 2750 *6000 2750 *6000 2750 *6000 2750 *6000 3100 *6000 3100 *6000	*3100 *3100	8190		
1500 mm	MH – stabilizers up – solid tires MH – stabilizers down – solid tires Lower (std UC) – f. stabilizer & r. dozer up Lower (std UC) – f. stabilizer & r. dozer down Lower (std UC) – f. dozer & r. stabilizer up Lower (std UC) – f. dozer & r. stabilizer down Lower (std UC) – 2 sets stabilizers up Lower (std UC) – 2 sets stabilizers down			7850 *11 700 7850 *11 700 7850 *11 700 8150 *11 700 8150 *11 700 8100 *11 700 *11 700 *11 700	7850 *11 700 7300 *11 700 7300 *11 700 5300 *11 700 5300 *11 700 5300 *11 700 *11 700 *11 700	*11 700 *8250 *11 700 *8250 *11 700 *8250 8950 *8250 8950 *8250 9300 *8250 9300 *8250	5300 *8250 5300 *8250 5150 *8250 4850 *8250 4850 *8250 4700 *8250 *8250 *8250	3850 *6300 3850 *6300 3600 *6300 3600 *6300 3600 *6300 3400 *6300 *6300 *6300	3850 *6300 3550 *6300 3550 *6300 3400 *6300 3400 *6300 3400 *6300 *6300 *6300	2750 *6300 2600 *6300 2600 *6300 2600 *6300 2600 *6300 2900 *6300 *6300 *6300	*3250 *3250	8280		
0 mm	MH – stabilizers up – solid tires MH – stabilizers down – solid tires Lower (std UC) – f. stabilizer & r. dozer up Lower (std UC) – f. stabilizer & r. dozer down Lower (std UC) – f. dozer & r. stabilizer up Lower (std UC) – f. dozer & r. stabilizer down Lower (std UC) – 2 sets stabilizers up Lower (std UC) – 2 sets stabilizers down			7700 *11 650 *11 650 *11 650 7800 *11 650 *11 650 *11 650 7900 *11 650 *11 650 *11 650 7850 *11 650 *11 650 *11 650	7700 *11 650 7050 *11 650 7050 *11 650 8700 *11 650 8700 *11 650 5100 *11 650 9000 *11 650 5150 *11 650 11 250 *11 650	5350 *8500 *8500 *8500 5000 *8500 *8500 *8500 5200 *8500 *8500 *8500 5200 *8500 *8500 *8500	5100 *8500 4700 *8500 4700 *8500 5700 *8500 5700 *8500 4500 *8500 5850 *8500 4650 *8500 7100 *8500	3650 *6550 *6550 *6550 3450 *6550 *6550 *6550 3400 *6550 *6550 *6550 3450 *6550 *6550 *6550	3750 *6550 2700 *6550 3450 *6550 *6550 *6550 3300 *6550 *6550 *6550 3300 *6550 *6550 *6550	2400 *6550 3000 *6550 2550 *6550 *6550 *6550 2550 *6550 *6550 *6550 2550 *6550 *6550 *6550	*3500 *3500	8070		
-1500 mm	MH – stabilizers up – solid tires MH – stabilizers down – solid tires Lower (std UC) – f. stabilizer & r. dozer up Lower (std UC) – f. stabilizer & r. dozer down Lower (std UC) – f. dozer & r. stabilizer up Lower (std UC) – f. dozer & r. stabilizer down Lower (std UC) – 2 sets stabilizers up Lower (std UC) – 2 sets stabilizers down	*10 000 *10 000 *10 000 *10 000 *10 000 *10 000 *10 000 *10 000 *10 000 *10 000 *10 000 *10 000 *10 000 *10 000	9900 *10 000 9400 *10 000 9400 *10 000 9400 *10 000 9400 *10 000 9500 *10 000 *10 000 *10 000	7650 *10 600 7550 *10 600 7000 *10 600 8850 *10 600 5050 *10 600 9000 *10 600 5100 *10 600 *10 600 *10 600	5300 *7900 5050 *7900 4950 *7900 *7900 *7900 5600 *7900 4450 *7900 4600 *7900 *7900 *7900	5050 *7900 4650 *7900 4650 *7900 5600 *7900 3400 *7900 5800 *7900 4600 *7900 7050 *7900	3600 *5150 3600 *5150 3400 *5150 *5150 *5150 3800 *5150 *5150 *5150 3750 *5150 *5150 *5150	3750 *5150 3450 *5150 3450 *5150 2550 *5150 3300 *5150 *5150 *5150 3450 *5150 *5150 *5150	2700 *5150 2550 *5150 2550 *5150 4150 *5150 2550 *5150 *5150 *5150 2600 *5150 *5150 *5150	3750 *4000 3750 *4000 3450 *4000 *4000 *4000 3750 *4000 *4000 *4000 3400 *4000 *4000 *4000	*2650 *2650	7550		
-3000 mm	MH – stabilizers up – solid tires MH – stabilizers down – solid tires Lower (std UC) – f. stabilizer & r. dozer up Lower (std UC) – f. stabilizer & r. dozer down Lower (std UC) – f. dozer & r. stabilizer up Lower (std UC) – f. dozer & r. stabilizer down Lower (std UC) – 2 sets stabilizers up Lower (std UC) – 2 sets stabilizers down			7800 *8500 *8500 *8500 7850 *8500 *8500 *8500 7950 *8500 *8500 *8500 7900 *8500 *8500 *8500	7800 *8500 7100 *8500 7100 *8500 8500 *8500 8800 *8500 5150 *8500 5200 *8500 *8500 *8500	5400 *6150 *6150 *6150 5150 *6150 *6150 *6150 5200 *6150 *6150 *6150 5200 *6150 *6150 *6150	5150 *6150 4700 *6150 4700 *6150 5850 *6150 4550 *6150 5850 *6150 4700 *6150 *6150 *6150	3650 *6150 *6150 *6150 3450 *6150 *6150 *6150 3450 *6150 *6150 *6150 3500 *6150 *6150 *6150						

*Limited by hydraulic rather than tipping load.

Lift capacity ratings are based on ISO 10567:2007, they do not exceed 87% of hydraulic lifting capacity or 75% of tipping load. The load point is the center line of the bucket pivot mounting pin on the stick. The oscillating axle must be locked. Lifting capacities are based on the machine standing on a firm uniform supporting surface and the Variable Boom Cylinder adjusted to the maximum length. For lifting capacity including bucket and/or quick coupler, the respective weight has to be subtracted from above values. The use of a work tool attachment point to handle/lift objects, could affect the machine lift performance.

Always refer to the appropriate Operation and Maintenance Manual for specific product information.

Lifting Capacities • MH3024 (Grenoble Sourced)

Material Handlers

Lift Capacities

All values are in lb, bucket cylinder and linkage installed, hydraulic cab riser, work tool: none, with counterweight (9040 lb), heavy lift on.

 Load point height

 Load over front

 Load over rear

 Load over side













 Load at maximum reach (sticknose/bucket pin)

Undercarriage

Boom VA

Stick 8'2"

MH or Standard

Stick 8'2"	Undercarriage configuration	10 ft			15 ft			20 ft			25 ft			ft					
																			
25 ft	MH – stabilizers up – solid tires													*8600	*8600	*8600			
	MH – stabilizers down – solid tires													*8600	*8600	*8600			
	Lower (std UC) – f. stabilizer & r. dozer up													*8600	*8600	*8600			
	Lower (std UC) – f. stabilizer & r. dozer down													*8600	*8600	*8600			
	Lower (std UC) – f. dozer & r. stabilizer up													*8600	*8600	*8600			
	Lower (std UC) – f. dozer & r. stabilizer down													*8600	*8600	*8600			
	Lower (std UC) – 2 sets stabilizers up													*8600	*8600	*8600			
20 ft	MH – stabilizers up – solid tires							12,900	12,900	9600				*7400	*7400	*7400			
	MH – stabilizers down – solid tires							*14,800	*14,800	*14,800				*7400	*7400	*7400			
	Lower (std UC) – f. stabilizer & r. dozer up							12,600	11,900	9200				*7400	*7400	*7000			
	Lower (std UC) – f. stabilizer & r. dozer down							*14,800	*14,800	14,100				*7400	*7400	*7400			
	Lower (std UC) – f. dozer & r. stabilizer up							13,000	11,500	9200				*7400	*7400	*7000			
	Lower (std UC) – f. dozer & r. stabilizer down							*14,800	*14,800	14,500				*7400	*7400	*7400			
	Lower (std UC) – 2 sets stabilizers up							13,000	11,900	9300				*7400	*7400	*7100			
15 ft	MH – stabilizers up – solid tires							*18,900	*18,900	*18,900				*7000	*7000	*6100			
	MH – stabilizers down – solid tires							*18,900	*18,900	*15,400				*7000	*7000	*7000			
	Lower (std UC) – f. stabilizer & r. dozer up							*18,900	18,300	13,800	12,300	11,600	8800	8500	8000	6100	*7000	*7000	5800
	Lower (std UC) – f. stabilizer & r. dozer down							*18,900	*18,900	*15,400	*15,400	13,800	*10,700	*10,700	9500	*7000	*7000	*7000	
	Lower (std UC) – f. dozer & r. stabilizer up							*18,900	17,700	13,800	12,700	11,200	8800	8800	7700	6100	*7000	*7000	5800
	Lower (std UC) – f. dozer & r. stabilizer down							*18,900	*18,900	*15,400	*15,400	14,200	*10,700	*10,700	9800	*7000	*7000	*7000	
	Lower (std UC) – 2 sets stabilizers up							*18,900	18,200	14,000	12,600	11,600	8900	8700	8000	6100	*7000	*7000	5900
10 ft	MH – stabilizers up – solid tires							*18,900	*18,900	*18,900	*15,400	*15,400	*10,700	*10,700	*10,700	*7000	*7000	*7000	
	MH – stabilizers down – solid tires							18,400	18,400	13,200	12,000	12,500	9300	8700	8500	6200	*6900	*5500	
	Lower (std UC) – f. stabilizer & r. dozer up							*22,700	*22,700	*22,700	*16,300	*16,300	*16,300	*13,000	*13,000	*13,000	*6900	*6900	
	Lower (std UC) – f. stabilizer & r. dozer down							18,200	16,900	12,600	11,700	11,100	8300	8300	7900	5900	*6900	*5200	
	Lower (std UC) – f. dozer & r. stabilizer up							*22,700	*22,700	20,600	*16,300	*16,300	13,200	*13,000	*13,000	9400	*6900	*6900	
	Lower (std UC) – f. dozer & r. stabilizer down							18,600	16,300	12,600	12,100	10,700	8300	8600	7600	5900	*6900	6700	
	Lower (std UC) – 2 sets stabilizers up							*22,700	*22,700	21,300	*16,300	*16,300	13,600	*13,000	*13,000	9600	*6900	*6900	
5 ft	MH – stabilizers up – solid tires							17,200	17,200	12,100	11,400	11,400	8200	8300	8300	6000	*7100	*7100	
	MH – stabilizers down – solid tires							*25,300	*25,300	*25,300	*17,800	*17,800	*13,600	*13,600	*13,600	13,500	*7100	*7100	
	Lower (std UC) – f. stabilizer & r. dozer up							16,900	15,700	11,500	11,100	10,500	7800	8000	7600	5600	7100	6700	
	Lower (std UC) – f. stabilizer & r. dozer down							*25,300	*25,300	19,300	*17,800	*17,800	12,600	*13,600	*13,600	9100	*7100	*7100	
	Lower (std UC) – f. dozer & r. stabilizer up							17,600	15,100	11,500	11,600	10,100	7800	8400	7300	5600	*7100	6400	
	Lower (std UC) – f. dozer & r. stabilizer down							*25,300	*25,300	20,000	*17,800	*17,800	13,000	*13,600	*13,600	9400	*7100	*7100	
	Lower (std UC) – 2 sets stabilizers up							17,400	15,600	11,600	11,500	10,400	7900	8300	7600	5700	*7100	6700	
0 ft	MH – stabilizers up – solid tires							*25,300	*25,300	24,800	*17,800	*17,800	*13,600	*13,600	*13,600	11,200	*7100	*7100	
	MH – stabilizers down – solid tires							16,800	16,800	11,600	11,000	11,000	7900	8100	8100	5800	7500	5400	
	Lower (std UC) – f. stabilizer & r. dozer up							*25,300	*25,300	*25,300	*18,400	*18,400	*14,100	*14,100	13,300	*7700	*7700		
	Lower (std UC) – f. stabilizer & r. dozer down							16,300	15,200	11,000	10,800	10,100	7400	7900	7400	5500	7300	6900	
	Lower (std UC) – f. dozer & r. stabilizer up							*25,300	*25,300	18,700	*18,400	*18,400	12,200	*14,100	*14,100	8900	*7700	*7700	
	Lower (std UC) – f. dozer & r. stabilizer down							17,000	14,600	11,000	11,200	9700	7400	8200	7100	5500	7600	6600	
	Lower (std UC) – 2 sets stabilizers up							*25,300	*25,300	19,400	*18,400	*18,400	12,600	*14,100	13,500	9200	*7700	*7700	
-5 ft	MH – stabilizers up – solid tires							*22,800	*22,800	21,300	16,500	16,500	11,500	10,900	10,900	7700	8200	8200	
	MH – stabilizers down – solid tires							*22,800	*22,800	*22,800	*23,000	*23,000	*17,100	*17,100	*17,100	*17,100	*8900	*8900	
	Lower (std UC) – f. stabilizer & r. dozer up							*22,800	*22,800	20,200	16,200	15,100	10,900	10,600	10,000	7300	8000	7600	
	Lower (std UC) – f. stabilizer & r. dozer down							*22,800	*22,800	*22,800	*23,000	*23,000	18,600	*17,100	*17,100	12,100	*8900	*8900	
	Lower (std UC) – f. dozer & r. stabilizer up							*22,800	*22,800	20,200	16,900	14,500	10,900	11,100	9600	7300	8300	7300	
	Lower (std UC) – f. dozer & r. stabilizer down							*22,800	*22,800	*22,800	*23,000	*23,000	19,300	*17,100	*17,100	12,500	*8900	*8900	
	Lower (std UC) – 2 sets stabilizers up							*22,800	*22,800	20,500	16,800	15,000	11,000	11,000	9900	7400	8300	7500	
-10 ft	MH – stabilizers up – solid tires							*22,800	*22,800	*22,800	*23,000	*23,000	*17,100	*17,100	*17,100	*8900	*8900	*8900	
	MH – stabilizers down – solid tires							16,700	16,700	11,700	11,100	11,100	7900						
	Lower (std UC) – f. stabilizer & r. dozer up							*18,300	*18,300	*18,300	*13,000	*13,000	*13,000	*13,000	*13,000	12,300			
	Lower (std UC) – f. stabilizer & r. dozer down							16,500	15,300	11,100	10,800	10,200	7500						
	Lower (std UC) – f. dozer & r. stabilizer up							*18,300	*18,300	*18,300	*13,000	*13,000	*13,000	*13,000	*13,000	12,300			
	Lower (std UC) – f. dozer & r. stabilizer down							17,100	14,700	11,100	11,200	9800	7500						
	Lower (std UC) – 2 sets stabilizers up							*18,300	*18,300	*18,300	*13,000	*13,000	*13,000	*13,000	*13,000	12,700			

*Limited by hydraulic rather than tipping load.

Lift capacity ratings are based on ISO 10567:2007, they do not exceed 87% of hydraulic lifting capacity or 75% of tipping load. The load point is the center line of the bucket pivot mounting pin on the stick. The oscillating axle must be locked. Lifting capacities are based on the machine standing on a firm uniform supporting surface and the Variable Boom Cylinder adjusted to the maximum length. For lifting capacity including bucket and/or quick coupler, the respective weight has to be subtracted from above values. The use of a work tool attachment point to handle/lift objects, could affect the machine lift performance.

Always refer to the appropriate Operation and Maintenance Manual for specific product information.

Lift Capacities

All values are in kg, bucket cylinder and linkage installed, hydraulic cab riser, work tool: none, with counterweight (5200 kg), heavy lift on.



Undercarriage

Boom
VA

Stick
2.5 m

MH or Standard

Undercarriage configuration	3000 mm			4500 mm			6000 mm			7500 mm			mm			
7500 mm MH – stabilizers up – solid tires MH – stabilizers down – solid tires Lower (std UC) – f. stabilizer & r. dozer up Lower (std UC) – f. stabilizer & r. dozer down Lower (std UC) – f. dozer & r. stabilizer up Lower (std UC) – f. dozer & r. stabilizer down Lower (std UC) – 2 sets stabilizers up Lower (std UC) – 2 sets stabilizers down													*3850	*3850	*3850	
														*3850	*3850	*3850
														*3850	*3850	*3850
														*3850	*3850	*3850
														*3850	*3850	*3850
														*3850	*3850	*3850
														*3850	*3850	*3850
6000 mm MH – stabilizers up – solid tires MH – stabilizers down – solid tires Lower (std UC) – f. stabilizer & r. dozer up Lower (std UC) – f. stabilizer & r. dozer down Lower (std UC) – f. dozer & r. stabilizer up Lower (std UC) – f. dozer & r. stabilizer down Lower (std UC) – 2 sets stabilizers up Lower (std UC) – 2 sets stabilizers down							6650	6650	5050					*3350	*3350	*3350
							*6750	*6750	*6750					*3350	*3350	*3350
							6600	6200	4850					*3350	*3350	*3350
							*6750	*6750	*6750					*3350	*3350	*3350
							*6750	6050	4850					*3350	*3350	*3350
							*6750	*6750	*6750					*3350	*3350	*3350
							*6750	6200	4900					*3350	*3350	*3350
4500 mm MH – stabilizers up – solid tires MH – stabilizers down – solid tires Lower (std UC) – f. stabilizer & r. dozer up Lower (std UC) – f. stabilizer & r. dozer down Lower (std UC) – f. dozer & r. stabilizer up Lower (std UC) – f. dozer & r. stabilizer down Lower (std UC) – 2 sets stabilizers up Lower (std UC) – 2 sets stabilizers down				*8750	*8750	7550	6500	6500	4900	4550	4550	3450	*3150	*3150	*3150	
				*8750	*8750	*8750	*7100	*7100	*7100	*5800	*5800	*5800	*3150	*3150	*3150	
				*8750	*8750	7250	6400	6050	4700	4500	4250	3300	*3150	*3150	3050	
				*8750	*8750	*8750	*7100	*7100	*7100	*5800	*5800	*5000	*3150	*3150	*3150	
				*8750	*8750	7250	6600	5850	4700	4650	4100	3300	*3150	*3150	3050	
				*8750	*8750	*8750	*7100	*7100	*7100	*5800	*5800	5150	*3150	*3150	*3150	
				*8750	*8750	7300	6600	6050	4750	4600	4250	3300	*3150	*3150	3050	
3000 mm MH – stabilizers up – solid tires MH – stabilizers down – solid tires Lower (std UC) – f. stabilizer & r. dozer up Lower (std UC) – f. stabilizer & r. dozer down Lower (std UC) – f. dozer & r. stabilizer up Lower (std UC) – f. dozer & r. stabilizer down Lower (std UC) – 2 sets stabilizers up Lower (std UC) – 2 sets stabilizers down				9550	9550	6950	6250	6250	4650	4500	4500	3350	*3100	*3100	2900	
				*10 500	*10 500	*10 500	*7550	*7550	*7550	*6000	*6000	*6000	*3100	*3100	*3100	
				9500	8800	6650	6150	5800	4450	4400	4150	3200	*3100	*3100	2750	
				*10 500	*10 500	*10 500	*7550	*7550	6850	*6000	*6000	4900	*3100	*3100	*3100	
				9800	8550	6650	6350	5600	4450	4550	4000	3200	*3100	*3100	2750	
				*10 500	*10 500	*10 500	*7550	*7550	7050	*6000	*6000	5050	*3100	*3100	*3100	
				9750	8750	6750	6300	5750	4500	4500	4150	3200	*3100	*3100	2800	
1500 mm MH – stabilizers up – solid tires MH – stabilizers down – solid tires Lower (std UC) – f. stabilizer & r. dozer up Lower (std UC) – f. stabilizer & r. dozer down Lower (std UC) – f. dozer & r. stabilizer up Lower (std UC) – f. dozer & r. stabilizer down Lower (std UC) – 2 sets stabilizers up Lower (std UC) – 2 sets stabilizers down				9000	9000	6450	6000	6000	4400	4350	4350	3250	*3250	*3250	2800	
				*11 700	*11 700	*11 700	*8250	*8250	*8250	*6300	*6300	*6300	*3250	*3250	*3250	
				8900	8250	6150	5900	5550	4200	4250	4050	3050	*3250	*3250	2650	
				*11 700	*11 700	10 100	*8250	*8250	6600	*6300	*6300	4800	*3250	*3250	*3250	
				9200	8000	6150	6100	5350	4200	4400	3900	3050	*3250	*3250	2650	
				*11 700	*11 700	10 450	*8250	*8250	6800	*6300	*6300	4900	*3250	*3250	*3250	
				9150	8200	6200	6050	5500	4250	4400	4000	3100	*3250	*3250	2700	
0 mm MH – stabilizers up – solid tires MH – stabilizers down – solid tires Lower (std UC) – f. stabilizer & r. dozer up Lower (std UC) – f. stabilizer & r. dozer down Lower (std UC) – f. dozer & r. stabilizer up Lower (std UC) – f. dozer & r. stabilizer down Lower (std UC) – 2 sets stabilizers up Lower (std UC) – 2 sets stabilizers down				8750	8750	6200	5800	5800	4250	4250	4250	3150	*3500	*3500	2850	
				*11 650	*11 650	*11 650	*8500	*8500	*8500	*6550	*6550	*6550	*3500	*3500	*3500	
				8850	8000	5900	5700	5350	4050	4200	3950	3000	*3500	*3500	2700	
				*11 650	*11 650	9800	*8500	*8500	6400	*6550	*6550	4700	*3500	*3500	*3500	
				8950	7750	5900	5900	5150	4050	4350	3800	3000	*3500	*3500	2700	
				*11 650	*11 650	10 150	*8500	*8500	6600	*6550	*6550	4800	*3500	*3500	*3500	
				8900	7950	6000	5850	5350	4100	4300	3950	3050	*3500	*3500	2750	
-1500 mm MH – stabilizers up – solid tires MH – stabilizers down – solid tires Lower (std UC) – f. stabilizer & r. dozer up Lower (std UC) – f. stabilizer & r. dozer down Lower (std UC) – f. dozer & r. stabilizer up Lower (std UC) – f. dozer & r. stabilizer down Lower (std UC) – 2 sets stabilizers up Lower (std UC) – 2 sets stabilizers down		*10 000	*10 000	*10 000	8700	8700	6150	5750	5750	4200	4250	3150	*4000	*4000	3100	
		*10 000	*10 000	*10 000	*10 600	*10 600	*10 600	*7900	*7900	*7900	*5150	*5150	*5150	*4000	*4000	*4000
		*10 000	*10 000	*10 000	8600	7950	5900	5650	5300	4000	4200	3950	3000	*4000	3900	2950
		*10 000	*10 000	*10 000	*10 600	*10 600	9750	*7900	*7900	6350	*5150	*5150	4700	*4000	*4000	*4000
		*10 000	*10 000	*10 000	8900	7700	5900	5850	5100	4000	4350	3800	3000	*4000	3800	2950
		*10 000	*10 000	*10 000	*10 600	*10 600	10 150	*7900	*7900	6550	*5150	*5150	4800	*4000	*4000	*4000
		*10 000	*10 000	*10 000	8850	7950	5950	5800	5300	4050	4300	3950	3050	*4000	3900	3000
-3000 mm MH – stabilizers up – solid tires MH – stabilizers down – solid tires Lower (std UC) – f. stabilizer & r. dozer up Lower (std UC) – f. stabilizer & r. dozer down Lower (std UC) – f. dozer & r. stabilizer up Lower (std UC) – f. dozer & r. stabilizer down Lower (std UC) – 2 sets stabilizers up Lower (std UC) – 2 sets stabilizers down				*8500	*8500	6250	5800	5800	4250							
				*8500	*8500	*8500	*6150	*6150	*6150							
				*8500	8050	6000	5700	5400	4050							
				*8500	*8500	*8500	*6150	*6150	*6150							
				*8500	7800	6000	5900	5200	4050							
				*8500	*8500	*8500	*6150	*6150	*6150							
				*8500	8050	6050	5900	5350	4100							

*Limited by hydraulic rather than tipping load.

Lift capacity ratings are based on ISO 10567:2007, they do not exceed 87% of hydraulic lifting capacity or 75% of tipping load. The load point is the center line of the bucket pivot mounting pin on the stick. The oscillating axle must be locked. Lifting capacities are based on the machine standing on a firm uniform supporting surface and the Variable Boom Cylinder adjusted to the maximum length. For lifting capacity including bucket and/or quick coupler, the respective weight has to be subtracted from above values. The use of a work tool attachment point to handle/lift objects, could affect the machine lift performance.

Always refer to the appropriate Operation and Maintenance Manual for specific product information.

Lifting Capacities ● MH3024 (Grenoble Sourced)

Material Handlers

Lift Capacities

All values are in lb, bucket cylinder and linkage installed, hydraulic cab riser, work tool: none, with counterweight (11,470 lb), heavy lift on.

Load point height

Load over front

Load over rear

Load over side

Load at maximum reach (sticknose/bucket pin)

Undercarriage

Boom VA

Stick 8'2"

MH or Standard

	Undercarriage configuration	10 ft			15 ft			20 ft			25 ft				ft
25 ft	MH – stabilizers up – solid tires														
	MH – stabilizers down – solid tires														
	Lower (std UC) – f. stabilizer & r. dozer up														
	Lower (std UC) – f. stabilizer & r. dozer down														
	Lower (std UC) – f. dozer & r. stabilizer up														
	Lower (std UC) – f. dozer & r. stabilizer down														
	Lower (std UC) – 2 sets stabilizers up														
20 ft	MH – stabilizers up – solid tires							14,300	14,300	10,900					
	MH – stabilizers down – solid tires							*14,800	*14,800	*14,800					
	Lower (std UC) – f. stabilizer & r. dozer up							14,200	13,400	10,400					
	Lower (std UC) – f. stabilizer & r. dozer down							*14,800	*14,800	*14,800					
	Lower (std UC) – f. dozer & r. stabilizer up							14,600	13,000	10,400					
	Lower (std UC) – f. dozer & r. stabilizer down							*14,800	*14,800	*14,800					
	Lower (std UC) – 2 sets stabilizers up							14,500	13,300	10,500					
15 ft	MH – stabilizers up – solid tires							*18,900	*18,900	*14,800					
	MH – stabilizers down – solid tires							*18,900	*18,900	*15,400					
	Lower (std UC) – f. stabilizer & r. dozer up							*18,900	*18,900	*15,400					
	Lower (std UC) – f. stabilizer & r. dozer down							*18,900	*18,900	*15,400					
	Lower (std UC) – f. dozer & r. stabilizer up							*18,900	*18,900	*15,400					
	Lower (std UC) – f. dozer & r. stabilizer down							*18,900	*18,900	*15,400					
	Lower (std UC) – 2 sets stabilizers up							*18,900	*18,900	*15,400					
10 ft	MH – stabilizers up – solid tires							20,600	20,600	15,900					
	MH – stabilizers down – solid tires							*22,700	*22,700	*22,700					
	Lower (std UC) – f. stabilizer & r. dozer up							20,500	19,000	14,400					
	Lower (std UC) – f. stabilizer & r. dozer down							*22,700	*22,700	*22,700					
	Lower (std UC) – f. dozer & r. stabilizer up							21,100	18,400	14,400					
	Lower (std UC) – f. dozer & r. stabilizer down							*22,700	*22,700	*22,700					
	Lower (std UC) – 2 sets stabilizers up							21,000	18,900	14,600					
5 ft	MH – stabilizers up – solid tires							*22,700	*22,700	*22,700					
	MH – stabilizers down – solid tires							19,400	18,400	13,900					
	Lower (std UC) – f. stabilizer & r. dozer up							*25,300	*25,300	*25,300					
	Lower (std UC) – f. stabilizer & r. dozer down							19,200	17,800	13,300					
	Lower (std UC) – f. dozer & r. stabilizer up							*25,300	*25,300	*25,300					
	Lower (std UC) – f. dozer & r. stabilizer down							19,900	17,200	13,300					
	Lower (std UC) – 2 sets stabilizers up							*25,300	*25,300	*25,300					
0 ft	MH – stabilizers up – solid tires							18,800	18,800	13,400					
	MH – stabilizers down – solid tires							*25,300	*25,300	*25,300					
	Lower (std UC) – f. stabilizer & r. dozer up							18,600	17,300	12,800					
	Lower (std UC) – f. stabilizer & r. dozer down							*25,300	*25,300	*25,300					
	Lower (std UC) – f. dozer & r. stabilizer up							19,300	16,700	12,800					
	Lower (std UC) – f. dozer & r. stabilizer down							*25,300	*25,300	*25,300					
	Lower (std UC) – 2 sets stabilizers up							19,100	17,200	12,900					
-5 ft	MH – stabilizers up – solid tires							*22,800	*22,800	*22,800					
	MH – stabilizers down – solid tires							*22,800	*22,800	*23,000					
	Lower (std UC) – f. stabilizer & r. dozer up							*22,800	*22,800	*22,800					
	Lower (std UC) – f. stabilizer & r. dozer down							*22,800	*22,800	*23,000					
	Lower (std UC) – f. dozer & r. stabilizer up							*22,800	*22,800	*22,800					
	Lower (std UC) – f. dozer & r. stabilizer down							*22,800	*22,800	*23,000					
	Lower (std UC) – 2 sets stabilizers up							*22,800	*22,800	*22,800					
-10 ft	MH – stabilizers up – solid tires							*18,300	*18,300	*13,500					
	MH – stabilizers down – solid tires							*18,300	*18,300	*13,000					
	Lower (std UC) – f. stabilizer & r. dozer up							*18,300	*18,300	*13,000					
	Lower (std UC) – f. stabilizer & r. dozer down							*18,300	*18,300	*13,000					
	Lower (std UC) – f. dozer & r. stabilizer up							*18,300	*18,300	*13,000					
	Lower (std UC) – f. dozer & r. stabilizer down							*18,300	*18,300	*13,000					
	Lower (std UC) – 2 sets stabilizers up							*18,300	*18,300	*13,000					

*Limited by hydraulic rather than tipping load.

Lift capacity ratings are based on ISO 10567:2007, they do not exceed 87% of hydraulic lifting capacity or 75% of tipping load. The load point is the center line of the bucket pivot mounting pin on the stick. The oscillating axle must be locked. Lifting capacities are based on the machine standing on a firm uniform supporting surface and the Variable Boom Cylinder adjusted to the maximum length. For lifting capacity including bucket and/or quick coupler, the respective weight has to be subtracted from above values. The use of a work tool attachment point to handle/lift objects, could affect the machine lift performance.

Always refer to the appropriate Operation and Maintenance Manual for specific product information.

Lift Capacities

All values are in kg, bucket cylinder and linkage installed, hydraulic cab riser, work tool: none, with counterweight (4100 kg), heavy lift on.



Undercarriage

Boom VA

Stick 2.9 m

MH or Standard

Undercarriage configuration	3000 mm			4500 mm			6000 mm			7500 mm			Stick			mm		
	Load point height	Load over front	Load over rear	Load point height	Load over front	Load over rear	Load point height	Load over front	Load over rear	Load point height	Load over front	Load over rear	Load point height	Load over front	Load over rear			
7500 mm	MH – stabilizers up – solid tires																	
	MH – stabilizers down – solid tires																	
	Lower (std UC) – f. stabilizer & r. dozer up																	
	Lower (std UC) – f. stabilizer & r. dozer down																	
	Lower (std UC) – f. dozer & r. stabilizer up																	
	Lower (std UC) – f. dozer & r. stabilizer down																	
	Lower (std UC) – 2 sets stabilizers up																	
	Lower (std UC) – 2 sets stabilizers down																	
6000 mm	MH – stabilizers up – solid tires																	
	MH – stabilizers down – solid tires																	
	Lower (std UC) – f. stabilizer & r. dozer up																	
	Lower (std UC) – f. stabilizer & r. dozer down																	
	Lower (std UC) – f. dozer & r. stabilizer up																	
	Lower (std UC) – f. dozer & r. stabilizer down																	
	Lower (std UC) – 2 sets stabilizers up																	
	Lower (std UC) – 2 sets stabilizers down																	
4500 mm	MH – stabilizers up – solid tires																	
	MH – stabilizers down – solid tires																	
	Lower (std UC) – f. stabilizer & r. dozer up																	
	Lower (std UC) – f. stabilizer & r. dozer down																	
	Lower (std UC) – f. dozer & r. stabilizer up																	
	Lower (std UC) – f. dozer & r. stabilizer down																	
	Lower (std UC) – 2 sets stabilizers up																	
	Lower (std UC) – 2 sets stabilizers down																	
3000 mm	MH – stabilizers up – solid tires																	
	MH – stabilizers down – solid tires																	
	Lower (std UC) – f. stabilizer & r. dozer up																	
	Lower (std UC) – f. stabilizer & r. dozer down																	
	Lower (std UC) – f. dozer & r. stabilizer up																	
	Lower (std UC) – f. dozer & r. stabilizer down																	
	Lower (std UC) – 2 sets stabilizers up																	
	Lower (std UC) – 2 sets stabilizers down																	
1500 mm	MH – stabilizers up – solid tires																	
	MH – stabilizers down – solid tires																	
	Lower (std UC) – f. stabilizer & r. dozer up																	
	Lower (std UC) – f. stabilizer & r. dozer down																	
	Lower (std UC) – f. dozer & r. stabilizer up																	
	Lower (std UC) – f. dozer & r. stabilizer down																	
	Lower (std UC) – 2 sets stabilizers up																	
	Lower (std UC) – 2 sets stabilizers down																	
0 mm	MH – stabilizers up – solid tires																	
	MH – stabilizers down – solid tires																	
	Lower (std UC) – f. stabilizer & r. dozer up																	
	Lower (std UC) – f. stabilizer & r. dozer down																	
	Lower (std UC) – f. dozer & r. stabilizer up																	
	Lower (std UC) – f. dozer & r. stabilizer down																	
	Lower (std UC) – 2 sets stabilizers up																	
	Lower (std UC) – 2 sets stabilizers down																	
-1500 mm	MH – stabilizers up – solid tires																	
	MH – stabilizers down – solid tires																	
	Lower (std UC) – f. stabilizer & r. dozer up																	
	Lower (std UC) – f. stabilizer & r. dozer down																	
	Lower (std UC) – f. dozer & r. stabilizer up																	
	Lower (std UC) – f. dozer & r. stabilizer down																	
	Lower (std UC) – 2 sets stabilizers up																	
	Lower (std UC) – 2 sets stabilizers down																	
-3000 mm	MH – stabilizers up – solid tires																	
	MH – stabilizers down – solid tires																	
	Lower (std UC) – f. stabilizer & r. dozer up																	
	Lower (std UC) – f. stabilizer & r. dozer down																	
	Lower (std UC) – f. dozer & r. stabilizer up																	
	Lower (std UC) – f. dozer & r. stabilizer down																	
	Lower (std UC) – 2 sets stabilizers up																	
	Lower (std UC) – 2 sets stabilizers down																	

* Limited by hydraulic rather than tipping load.

Lift capacity ratings are based on ISO 10567:2007, they do not exceed 87% of hydraulic lifting capacity or 75% of tipping load. The load point is the center line of the bucket pivot mounting pin on the stick. The oscillating axle must be locked. Lifting capacities are based on the machine standing on a firm uniform supporting surface and the Variable Boom Cylinder adjusted to the maximum length. For lifting capacity including bucket and/or quick coupler, the respective weight has to be subtracted from above values. The use of a work tool attachment point to handle/lift objects, could affect the machine lift performance.

Always refer to the appropriate Operation and Maintenance Manual for specific product information.

Lift Capacities

All values are in lb, bucket cylinder and linkage installed, hydraulic cab riser, work tool: none, with counterweight (9040 lb), heavy lift on.

		Load point height			Load over front			Load over rear			Load over side			Load at maximum reach (sticknose/bucket pin)						
Undercarriage		Boom VA									Stick 9'6"									
MH or Standard		10 ft			15 ft			20 ft			25 ft			ft						
Undercarriage configuration																	ft			
30 ft	MH – stabilizers up – solid tires																	9500	9500	9500
	MH – stabilizers down – solid tires																	9500	9500	9500
	Lower (std UC) – f. stabilizer & r. dozer up																	9500	9500	9500
	Lower (std UC) – f. stabilizer & r. dozer down																	9500	9500	9500
	Lower (std UC) – f. dozer & r. stabilizer up																	9500	9500	9500
	Lower (std UC) – f. dozer & r. stabilizer down																	9500	9500	9500
25 ft	MH – stabilizers up – solid tires																	9800	9800	9800
	MH – stabilizers down – solid tires																	9800	9800	9800
	Lower (std UC) – f. stabilizer & r. dozer up																	9800	9800	9800
	Lower (std UC) – f. stabilizer & r. dozer down																	9800	9800	9800
	Lower (std UC) – f. dozer & r. stabilizer up																	9800	9800	9800
	Lower (std UC) – f. dozer & r. stabilizer down																	9800	9800	9800
20 ft	MH – stabilizers up – solid tires																	13,000	13,000	9700
	MH – stabilizers down – solid tires																	13,800	13,800	9700
	Lower (std UC) – f. stabilizer & r. dozer up																	12,800	12,100	9300
	Lower (std UC) – f. stabilizer & r. dozer down																	13,800	13,800	9300
	Lower (std UC) – f. dozer & r. stabilizer up																	13,200	11,700	9300
	Lower (std UC) – f. dozer & r. stabilizer down																	13,800	13,800	9300
15 ft	MH – stabilizers up – solid tires																	17,000	17,000	14,200
	MH – stabilizers down – solid tires																	17,000	17,000	14,200
	Lower (std UC) – f. stabilizer & r. dozer up																	17,000	17,000	14,200
	Lower (std UC) – f. stabilizer & r. dozer down																	17,000	17,000	14,200
	Lower (std UC) – f. dozer & r. stabilizer up																	17,000	17,000	14,200
	Lower (std UC) – f. dozer & r. stabilizer down																	17,000	17,000	14,200
10 ft	MH – stabilizers up – solid tires																	18,700	18,700	15,800
	MH – stabilizers down – solid tires																	21,500	21,500	15,800
	Lower (std UC) – f. stabilizer & r. dozer up																	18,400	17,200	12,800
	Lower (std UC) – f. stabilizer & r. dozer down																	21,500	21,500	12,800
	Lower (std UC) – f. dozer & r. stabilizer up																	19,100	16,600	12,800
	Lower (std UC) – f. dozer & r. stabilizer down																	21,500	21,500	15,800
5 ft	MH – stabilizers up – solid tires																	17,300	17,300	12,200
	MH – stabilizers down – solid tires																	24,700	24,700	12,200
	Lower (std UC) – f. stabilizer & r. dozer up																	17,100	15,800	11,600
	Lower (std UC) – f. stabilizer & r. dozer down																	24,700	24,700	15,800
	Lower (std UC) – f. dozer & r. stabilizer up																	17,700	15,200	11,600
	Lower (std UC) – f. dozer & r. stabilizer down																	24,700	24,700	15,800
0 ft	MH – stabilizers up – solid tires																	16,600	16,600	11,500
	MH – stabilizers down – solid tires																	25,400	25,400	11,500
	Lower (std UC) – f. stabilizer & r. dozer up																	16,300	15,100	10,900
	Lower (std UC) – f. stabilizer & r. dozer down																	25,400	25,400	18,700
	Lower (std UC) – f. dozer & r. stabilizer up																	16,900	14,500	10,900
	Lower (std UC) – f. dozer & r. stabilizer down																	25,400	25,400	15,800
-5 ft	MH – stabilizers up – solid tires																	21,500	21,500	16,300
	MH – stabilizers down – solid tires																	21,500	21,500	16,300
	Lower (std UC) – f. stabilizer & r. dozer up																	21,500	19,800	16,300
	Lower (std UC) – f. stabilizer & r. dozer down																	21,500	21,500	16,300
	Lower (std UC) – f. dozer & r. stabilizer up																	21,500	19,800	16,300
	Lower (std UC) – f. dozer & r. stabilizer down																	21,500	21,500	16,300
-10 ft	MH – stabilizers up – solid tires																	16,500	16,500	11,400
	MH – stabilizers down – solid tires																	19,700	19,700	11,400
	Lower (std UC) – f. stabilizer & r. dozer up																	16,200	15,000	10,800
	Lower (std UC) – f. stabilizer & r. dozer down																	19,700	19,700	18,600
	Lower (std UC) – f. dozer & r. stabilizer up																	16,900	14,500	10,800
	Lower (std UC) – f. dozer & r. stabilizer down																	19,700	19,700	18,600

*Limited by hydraulic rather than tipping load.

Lift capacity ratings are based on ISO 10567:2007, they do not exceed 87% of hydraulic lifting capacity or 75% of tipping load. The load point is the center line of the bucket pivot mounting pin on the stick. The oscillating axle must be locked. Lifting capacities are based on the machine standing on a firm uniform supporting surface and the Variable Boom Cylinder adjusted to the maximum length. For lifting capacity including bucket and/or quick coupler, the respective weight has to be subtracted from above values. The use of a work tool attachment point to handle/lift objects, could affect the machine lift performance.

Always refer to the appropriate Operation and Maintenance Manual for specific product information.

Lift Capacities

All values are in kg, bucket cylinder and linkage installed, hydraulic cab riser, work tool: none, with counterweight (5200 kg), heavy lift on.

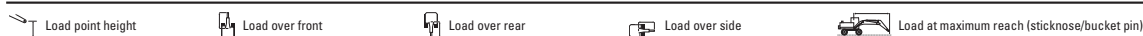

Undercarriage

Boom VA

Stick 2.9 m

MH or Standard

Undercarriage configuration	3000 mm			4500 mm			6000 mm			7500 mm			mm		
9000 mm	MH – stabilizers up – solid tires MH – stabilizers down – solid tires Lower (std UC) – f. dozer & r. stabilizer & r. dozer up Lower (std UC) – f. stabilizer & r. dozer down Lower (std UC) – f. dozer & r. stabilizer up Lower (std UC) – f. dozer & r. stabilizer down Lower (std UC) – 2 sets stabilizers up Lower (std UC) – 2 sets stabilizers down			*4200 *4200 *4200 *4200 *4200 *4200 *4200 *4200	*4200 *4200 *4200 *4200 *4200 *4200 *4200 *4200	*4200 *4200 *4200 *4200 *4200 *4200 *4200 *4200							*4150 *4150 *4150 *4150 *4150 *4150 *4150 *4150	4510	
7500 mm	MH – stabilizers up – solid tires MH – stabilizers down – solid tires Lower (std UC) – f. stabilizer & r. dozer up Lower (std UC) – f. stabilizer & r. dozer down Lower (std UC) – f. dozer & r. stabilizer up Lower (std UC) – f. dozer & r. stabilizer down Lower (std UC) – 2 sets stabilizers up Lower (std UC) – 2 sets stabilizers down					*5100 *5100 *5100 *5100 *5100 *5100 *5100 *5100	*5100 *5100 *5100 *5100 *5100 *5100 *5100 *5100	5100 4900 4900 4900 4900 4950 4950 4950					*3100 *3100 *3100 *3100 *3100 *3100 *3100 *3100	6410	
6000 mm	MH – stabilizers up – solid tires MH – stabilizers down – solid tires Lower (std UC) – f. stabilizer & r. dozer up Lower (std UC) – f. stabilizer & r. dozer down Lower (std UC) – f. dozer & r. stabilizer up Lower (std UC) – f. dozer & r. stabilizer down Lower (std UC) – 2 sets stabilizers up Lower (std UC) – 2 sets stabilizers down					*6300 *6300 *6300 *6300 *6300 *6300 *6300 *6300	*6300 *6300 *6300 *6300 *6300 *6300 *6300 *6300	6100 4900 4900 4900 4900 4950 4950 4950	*3150 *3150 *3150 *3150 *3150 *3150 *3150 *3150	*3150 *3150 *3150 *3150 *3150 *3150 *3150 *3150	*2750 *2750 *2750 *2750 *2750 *2750 *2750 *2750		7540		
4500 mm	MH – stabilizers up – solid tires MH – stabilizers down – solid tires Lower (std UC) – f. stabilizer & r. dozer up Lower (std UC) – f. stabilizer & r. dozer down Lower (std UC) – f. dozer & r. stabilizer up Lower (std UC) – f. dozer & r. stabilizer down Lower (std UC) – 2 sets stabilizers up Lower (std UC) – 2 sets stabilizers down					*7850 *7850 *7850 *7850 *7850 *7850 *7850 *7850	*7850 *7850 *7850 *7850 *7850 *7850 *7850 *7850	6550 6800 6450 6100 5900 4750 4600 4600	*4600 *4600 *4600 *4600 *4600 *4600 *4600 *4600	*3450 *3450 *3450 *3450 *3450 *3450 *3450 *3450	*2600 *2600 *2600 *2600 *2600 *2600 *2600 *2600		8230		
3000 mm	MH – stabilizers up – solid tires MH – stabilizers down – solid tires Lower (std UC) – f. stabilizer & r. dozer up Lower (std UC) – f. stabilizer & r. dozer down Lower (std UC) – f. dozer & r. stabilizer up Lower (std UC) – f. dozer & r. stabilizer down Lower (std UC) – 2 sets stabilizers up Lower (std UC) – 2 sets stabilizers down					*10 000 9600 9800 9850 9850 9850 9850 9850	*10 000 8900 8550 8550 8550 8550 8550 8550	*7300 6200 6400 6400 6400 6400 6400 6400	*4400 4450 4450 4450 4450 4450 4450 4450	*5800 5800 5800 5800 5800 5800 5800 5800	*3200 3200 3200 3200 3200 3200 3200 3200	*2600 *2600 *2600 *2600 *2600 *2600 *2600 *2600		8590	
1500 mm	MH – stabilizers up – solid tires MH – stabilizers down – solid tires Lower (std UC) – f. stabilizer & r. dozer up Lower (std UC) – f. stabilizer & r. dozer down Lower (std UC) – f. dozer & r. stabilizer up Lower (std UC) – f. dozer & r. stabilizer down Lower (std UC) – 2 sets stabilizers up Lower (std UC) – 2 sets stabilizers down					*11 400 9000 9250 9250 9250 9250 9250 9250	*11 400 8300 8050 8050 8050 8050 8050 8050	*7950 5900 6100 6100 6100 6100 6100 6100	*7950 7950 7950 7950 7950 7950 7950 7950	*6100 6100 6100 6100 6100 6100 6100 6100	*4350 4350 4350 4350 4350 4350 4350 4350	*2650 *2650 *2650 *2650 *2650 *2650 *2650 *2650		8670	
0 mm	MH – stabilizers up – solid tires MH – stabilizers down – solid tires Lower (std UC) – f. stabilizer & r. dozer up Lower (std UC) – f. stabilizer & r. dozer down Lower (std UC) – f. dozer & r. stabilizer up Lower (std UC) – f. dozer & r. stabilizer down Lower (std UC) – 2 sets stabilizers up Lower (std UC) – 2 sets stabilizers down					*8700 *11 750 8650 *11 750 8950 *11 750 8850 *11 750	*8700 *11 750 8650 *11 750 8950 *11 750 8850 *11 750	5800 *8500 5300 *8500 5150 *8500 5850 *8500	5800 *8500 5300 *8500 5150 *8500 5850 *8500	4200 *6450 4000 *6450 4000 *6450 4000 *6450	4250 *6450 4150 *6450 3800 *6450 3900 *6450	3100 *2850 2950 *2850 2950 *2850 2950 *2850	*2850 *2850 *2850 *2850 *2850 *2850 *2850 *2850		8470
-1500 mm	MH – stabilizers up – solid tires MH – stabilizers down – solid tires Lower (std UC) – f. stabilizer & r. dozer up Lower (std UC) – f. stabilizer & r. dozer down Lower (std UC) – f. dozer & r. stabilizer up Lower (std UC) – f. dozer & r. stabilizer down Lower (std UC) – 2 sets stabilizers up Lower (std UC) – 2 sets stabilizers down	*9450 *9450 *9450 *9450 *9450 *9450 *9450 *9450	*9450 *9450 *9450 *9450 *9450 *9450 *9450 *9450	*9450 *9450 *9450 *9450 *9450 *9450 *9450 *9450	*10 950 *10 950 *10 950 *10 950 *10 950 *10 950 *10 950 *10 950	*8000 8850 8850 8850 8850 8850 8850 8850	*6100 5700 5700 5700 5700 5700 5700 5700	*8100 *8100 *8100 *8100 *8100 *8100 *8100 *8100	*6000 3950 6300 3950 6500 3950 6500 3950	*6000 4100 6000 4100 6000 4100 6000 4100	*2900 *6000 4600 *2900 4750 *2900 4750 *2900 4750	*3250 *3250 *3250 *3250 *3250 *3250 *3250 *3250		7980	
-3000 mm	MH – stabilizers up – solid tires MH – stabilizers down – solid tires Lower (std UC) – f. stabilizer & r. dozer up Lower (std UC) – f. stabilizer & r. dozer down Lower (std UC) – f. dozer & r. stabilizer up Lower (std UC) – f. dozer & r. stabilizer down Lower (std UC) – 2 sets stabilizers up Lower (std UC) – 2 sets stabilizers down					*8700 *9150 8600 *9150 8900 *9150 8850 *9150	*8700 *9150 8600 *9150 8900 *9150 8850 *9150	6150 *6750 5850 *6750 5850 *6750 5850 *6750	5700 *6750 5300 *6750 5100 *6750 5850 *6750	5700 *6750 5300 *6750 5100 *6750 5850 *6750	4150 *6750 3950 *6750 3950 *6750 3950 *6750				

*Limited by hydraulic rather than tipping load.

Lift capacity ratings are based on ISO 10567:2007, they do not exceed 87% of hydraulic lifting capacity or 75% of tipping load. The load point is the center line of the bucket pivot mounting pin on the stick. The oscillating axle must be locked. Lifting capacities are based on the machine standing on a firm uniform supporting surface and the Variable Boom Cylinder adjusted to the maximum length. For lifting capacity including bucket and/or quick coupler, the respective weight has to be subtracted from above values. The use of a work tool attachment point to handle/lift objects, could affect the machine lift performance.

Always refer to the appropriate Operation and Maintenance Manual for specific product information.

Lifting Capacities • MH3024 (Grenoble Sourced)

Material Handlers

Lift Capacities

All values are in lb, bucket cylinder and linkage installed, hydraulic cab riser, work tool: none, with counterweight (11,470 lb), heavy lift on.

		Load point height			Load over front			Load over rear			Load over side			Load at maximum reach (sticknose/bucket pin)						
Undercarriage		Boom VA									Stick 9'6"									
MH or Standard		10 ft			15 ft			20 ft			25 ft					ft				
	Undercarriage configuration																			
30 ft	MH – stabilizers up – solid tires																*9500			
	MH – stabilizers down – solid tires																*9500			
	Lower (std UC) – f. stabilizer & r. dozer up																*9500			
	Lower (std UC) – f. stabilizer & r. dozer down																*9500			
	Lower (std UC) – f. dozer & r. stabilizer up																*9500			
	Lower (std UC) – f. dozer & r. stabilizer down																	*9500		
25 ft	MH – stabilizers up – solid tires									*9800	*9800	*9800					*7000			
	MH – stabilizers down – solid tires									*9800	*9800	*9800					*7000			
	Lower (std UC) – f. stabilizer & r. dozer up									*9800	*9800	*9800					*7000			
	Lower (std UC) – f. stabilizer & r. dozer down									*9800	*9800	*9800					*7000			
	Lower (std UC) – f. dozer & r. stabilizer up									*9800	*9800	*9800					*7000			
	Lower (std UC) – f. dozer & r. stabilizer down									*9800	*9800	*9800					*7000			
20 ft	MH – stabilizers up – solid tires									*13,800	*13,800	11,000					*6100			
	MH – stabilizers down – solid tires									*13,800	*13,800	13,800					*6100			
	Lower (std UC) – f. stabilizer & r. dozer up									*13,800	13,500	10,600					*6100			
	Lower (std UC) – f. stabilizer & r. dozer down									*13,800	*13,800	*13,800					*6100			
	Lower (std UC) – f. dozer & r. stabilizer up									*13,800	13,100	10,600					*6100			
	Lower (std UC) – f. dozer & r. stabilizer down									*13,800	*13,800	*13,800					*6100			
15 ft	MH – stabilizers up – solid tires									*17,000	*17,000	16,500	14,100	10,600	9900	9900	7400	*5800		
	MH – stabilizers down – solid tires									*17,000	*17,000	15,900	13,900	13,100	10,200	9700	9200	*5800		
	Lower (std UC) – f. stabilizer & r. dozer up									*17,000	*17,000	17,000	*17,000	*14,800	*14,800	*12,200	10,800	*5800		
	Lower (std UC) – f. stabilizer & r. dozer down									*17,000	*17,000	15,900	14,400	12,700	10,200	10,000	8900	*5800		
	Lower (std UC) – f. dozer & r. stabilizer up									*17,000	*17,000	17,000	*14,800	*14,800	*14,800	*12,200	11,100	*5800		
	Lower (std UC) – f. dozer & r. stabilizer down									*17,000	*17,000	16,100	14,300	13,100	10,300	10,000	9200	*5800		
10 ft	MH – stabilizers up – solid tires									*21,500	*21,500	20,800	20,800	15,200	13,500	13,500	10,100	9700	*5700	
	MH – stabilizers down – solid tires									*21,500	*21,500	20,800	20,800	15,200	13,500	13,500	10,100	9700	*5700	
	Lower (std UC) – f. stabilizer & r. dozer up									*21,500	*21,500	20,700	19,300	14,600	13,300	12,600	9700	9500	*5700	
	Lower (std UC) – f. stabilizer & r. dozer down									*21,500	*21,500	21,500	*21,500	*15,800	*15,800	*15,800	*12,600	11,600	*5700	
	Lower (std UC) – f. dozer & r. stabilizer up									*21,500	*21,500	21,400	18,700	14,800	13,800	12,200	9700	9800	*5700	
	Lower (std UC) – f. dozer & r. stabilizer down									*21,500	*21,500	21,500	*21,500	*15,800	*15,800	15,300	*12,600	10,900	*5700	
5 ft	MH – stabilizers up – solid tires									19,500	19,500	14,000	12,900	12,900	9500	9400	6900	*5900		
	MH – stabilizers down – solid tires									19,500	19,500	14,000	12,900	12,900	9500	9400	6900	*5900		
	Lower (std UC) – f. stabilizer & r. dozer up									19,400	17,900	13,400	12,700	11,900	9100	9200	6700	*5900		
	Lower (std UC) – f. stabilizer & r. dozer down									19,400	17,900	13,400	12,700	11,900	9100	9200	6700	*5900		
	Lower (std UC) – f. dozer & r. stabilizer up									19,400	17,900	13,400	12,700	11,900	9100	9200	6700	*5900		
	Lower (std UC) – f. dozer & r. stabilizer down									19,400	17,900	13,400	12,700	11,900	9100	9200	6700	*5900		
0 ft	MH – stabilizers up – solid tires									18,800	18,800	13,300	12,500	12,500	9100	9100	6700	*6300		
	MH – stabilizers down – solid tires									18,800	18,800	13,300	12,500	12,500	9100	9100	6700	*6300		
	Lower (std UC) – f. stabilizer & r. dozer up									18,600	17,200	12,700	12,200	11,500	8700	8900	6500	*6300		
	Lower (std UC) – f. stabilizer & r. dozer down									18,600	17,200	12,700	12,200	11,500	8700	8900	6500	*6300		
	Lower (std UC) – f. dozer & r. stabilizer up									18,200	16,600	12,700	12,700	11,100	8700	9300	6100	*6300		
	Lower (std UC) – f. dozer & r. stabilizer down									18,200	16,600	12,700	12,700	11,100	8700	9300	6100	*6300		
-5 ft	MH – stabilizers up – solid tires									*21,500	*21,500	*21,500	*21,500	18,500	18,500	13,100	12,300	8900	9100	8600
	MH – stabilizers down – solid tires									*21,500	*21,500	*21,500	*21,500	18,500	18,500	13,100	12,300	8900	9100	8600
	Lower (std UC) – f. stabilizer & r. dozer up									*21,500	*21,500	21,500	18,400	17,000	12,500	12,100	11,300	8500	8900	8400
	Lower (std UC) – f. stabilizer & r. dozer down									*21,500	*21,500	21,500	18,400	17,000	12,500	12,100	11,300	8500	8900	8400
	Lower (std UC) – f. dozer & r. stabilizer up									*21,500	*21,500	21,500	19,000	16,400	12,500	10,900	8500	9200	8100	6300
	Lower (std UC) – f. dozer & r. stabilizer down									*21,500	*21,500	21,500	19,000	16,400	12,500	10,900	8500	9200	8100	6300
-10 ft	MH – stabilizers up – solid tires									18,700	18,700	13,300	12,400	12,400	9000	9000	6600	*6300		
	MH – stabilizers down – solid tires									18,700	18,700	13,300	12,400	12,400	9000	9000	6600	*6300		
	Lower (std UC) – f. stabilizer & r. dozer up									18,500	17,100	12,700	12,100	11,400	8600	8700	6200	*6300		
	Lower (std UC) – f. stabilizer & r. dozer down									18,500	17,100	12,700	12,100	11,400	8600	8700	6200	*6300		
	Lower (std UC) – f. dozer & r. stabilizer up									19,100	16,600	12,700	12,600	11,000	8600	9100	6100	*7200		
	Lower (std UC) – f. dozer & r. stabilizer down									19,100	16,600	12,700	12,600	11,000	8600	9100	6100	*7200		

9

*Limited by hydraulic rather than tipping load.

Lift capacity ratings are based on ISO 10567:2007, they do not exceed 87% of hydraulic lifting capacity or 75% of tipping load. The load point is the center line of the bucket pivot mounting pin on the stick. The oscillating axle must be locked. Lifting capacities are based on the machine standing on a firm uniform supporting surface and the Variable Boom Cylinder adjusted to the maximum length. For lifting capacity including bucket and/or quick coupler, the respective weight has to be subtracted from above values. The use of a work tool attachment point to handle/lift objects, could affect the machine lift performance.

Always refer to the appropriate Operation and Maintenance Manual for specific product information.

Lift Capacities

All values are in kg, bucket cylinder and linkage installed, hydraulic cab riser, work tool: none, with counterweight (4100 kg), heavy lift on.



Undercarriage

Boom

Stick

MH or Standard

6.8 m MH

4.8 m Straight Stick

Load point height	Undercarriage configuration	4500 mm			6000 mm			7500 mm			9000 mm			10 500 mm			Load at maximum reach (sticknose/bucket pin)			mm
		Load over front	Load over rear	Load over side	Load over front	Load over rear	Load over side	Load over front	Load over rear	Load over side	Load over front	Load over rear	Load over side	Load over front	Load over rear	Load over side	Load over front	Load over rear	Load over side	
12 000 mm	MH – stabilizers up – solid tires	*8800	*8800	7050												*7750	*7750	5950	4970	
	MH – stabilizers down – solid tires	*8800	*8800	*8800												*7750	*7750	*7750		
	Lower (std UC) – f. stabilizer & r. dozer up	*8800	*8800	6750												*7750	7450	5700		
	Lower (std UC) – f. stabilizer & r. dozer down	*8800	*8800	*8800												*7750	*7750	*7750		
	Lower (std UC) – f. dozer & r. stabilizer up	*8800	8600	6750												*7750	7200	5700		
	Lower (std UC) – f. dozer & r. stabilizer down	*8800	*8800	*8800												*7750	*7750	*7750		
	Lower (std UC) – 2 sets stabilizers up	*8800	*8800	6850												*7750	7400	5750		
Lower (std UC) – 2 sets stabilizers down	*8800	*8800	*8800												*7750	*7750	*7750			
10 500 mm	MH – stabilizers up – solid tires				6100	6100	4600									4200	4200	3100	7350	
	MH – stabilizers down – solid tires				*8850	*8850	*8850									*6150	*6150	*6150		
	Lower (std UC) – f. stabilizer & r. dozer up				6000	5700	4400									4100	3900	2950		
	Lower (std UC) – f. stabilizer & r. dozer down				*8850	*8850	6700									*6150	*6150	4600		
	Lower (std UC) – f. dozer & r. stabilizer up				6200	5500	4400									4250	3750	2950		
	Lower (std UC) – f. dozer & r. stabilizer down				*8850	*8850	6900									*6150	*6150	4750		
	Lower (std UC) – 2 sets stabilizers up				6150	5650	4450									4200	3850	2950		
Lower (std UC) – 2 sets stabilizers down				*8850	*8850	8250									*6150	*6150	5650			
9000 mm	MH – stabilizers up – solid tires				6250	6250	4700	4200	4200	3100						3000	3000	2200	8860	
	MH – stabilizers down – solid tires				*9000	*9000	*9000	*7700	*7700	6700						*5550	*5550	4900		
	Lower (std UC) – f. stabilizer & r. dozer up				6150	5800	4500	4100	3900	2950						2950	2800	2050		
	Lower (std UC) – f. stabilizer & r. dozer down				*9000	*9000	6850	*7700	*7700	4600						*5550	*5550	3300		
	Lower (std UC) – f. dozer & r. stabilizer up				6350	5600	4500	4250	3750	2950						3050	2650	2050		
	Lower (std UC) – f. dozer & r. stabilizer down				*9000	*9000	7050	*7700	6800	4700						*5550	4950	3400		
	Lower (std UC) – 2 sets stabilizers up				6300	5750	4550	4200	3850	3000						3050	2750	2100		
Lower (std UC) – 2 sets stabilizers down				*9000	*9000	8350	*7700	6950	5600						*5550	5100	4100			
7500 mm	MH – stabilizers up – solid tires				6200	6200	4650	4200	4200	3100	3000	3000	2150			2450	2450	1700	9910	
	MH – stabilizers down – solid tires				*9050	*9050	*9050	*7700	*7700	6700	6000	6000	4850			5050	5050	4050		
	Lower (std UC) – f. stabilizer & r. dozer up				6100	5750	4450	4100	3900	2950	2900	2750	2050			2350	2250	1600		
	Lower (std UC) – f. stabilizer & r. dozer down				*9050	*9050	6800	*7700	*7700	4600	5700	5600	3300			4750	4650	2700		
	Lower (std UC) – f. dozer & r. stabilizer up				6300	5550	4450	4250	3750	2950	3000	2650	2050			2450	2150	1600		
	Lower (std UC) – f. dozer & r. stabilizer down				*9050	*9050	7000	*7700	6800	4700	6400	4850	3350			*5200	4050	2750		
	Lower (std UC) – 2 sets stabilizers up				6250	5750	4500	4200	3850	3000	3000	2750	2050			2450	2200	1650		
Lower (std UC) – 2 sets stabilizers down				*9050	*9050	8300	*7700	6950	5600	5850	5050	4050			4850	4200	3350			
6000 mm	MH – stabilizers up – solid tires				6000	6000	4500	4100	4100	3000	2950	2950	2100	2150	1500	2100	2100	1450	10 640	
	MH – stabilizers down – solid tires				*9400	*9400	*7850	*7850	6800	6000	6000	4800	4550	4550	3600	4450	4450	3550		
	Lower (std UC) – f. stabilizer & r. dozer up				5900	5550	4300	4000	3800	2850	2850	2700	2000	2100	1950	1400	2000	1900		1350
	Lower (std UC) – f. stabilizer & r. dozer down				*9400	*9400	6600	7800	7600	4500	5650	5550	3250	4250	4200	2400	4150	4100		2300
	Lower (std UC) – f. dozer & r. stabilizer up				6100	5400	4300	4150	3850	2850	2950	2600	2000	2150	1850	1400	2100	1800		1350
	Lower (std UC) – f. dozer & r. stabilizer down				*9400	*9400	6800	*7850	6850	4600	6350	4850	3300	4800	3650	2450	4650	3550		2400
	Lower (std UC) – 2 sets stabilizers up				6050	5550	4350	4100	3750	2900	2950	2700	2000	2150	1950	1400	2100	1900		1350
Lower (std UC) – 2 sets stabilizers down				*9400	*9400	8100	*7850	6850	5500	5800	5000	4000	4400	3750	3000	4250	3650	2900		
4500 mm	MH – stabilizers up – solid tires	9200	9200	6700	5700	5700	4150	3900	3900	2850	2850	2850	2050	2150	1450	1900	1900	1250	11 120	
	MH – stabilizers down – solid tires	*12 850	*12 850	*12 850	*9900	*9900	9350	8000	8000	6400	5850	5850	4700	4500	4500	3600	4050	4050		3250
	Lower (std UC) – f. stabilizer & r. dozer up	9100	8450	6400	5550	5250	4000	3800	3800	2700	2750	2600	1900	2050	1950	1350	1800	1700		1150
	Lower (std UC) – f. stabilizer & r. dozer down	*12 850	*12 850	10 250	*9900	*9900	6250	7600	7400	4300	5500	5450	3150	4200	4150	2350	3800	3750		2150
	Lower (std UC) – f. dozer & r. stabilizer up	9400	8200	6400	5750	5050	4000	3950	3450	2700	2850	2500	1900	2150	1850	1350	1900	1600		1150
	Lower (std UC) – f. dozer & r. stabilizer down	*12 850	*12 850	10 600	*9900	9550	6450	*8050	6450	4450	6200	4750	3250	4750	3600	2400	4300	3250		2150
	Lower (std UC) – 2 sets stabilizers up	9350	8450	6450	5750	5250	4000	3950	3600	2750	2850	2600	1950	2150	1950	1400	1900	1700		1200
Lower (std UC) – 2 sets stabilizers down	*12 850	*12 850	*12 850	*9900	9800	7750	7800	6650	5300	5700	4900	3900	4350	3750	2950	3900	3350	2650		

* Limited by hydraulic rather than tipping load.

(continued on next page)

Lift capacity ratings are based on ISO 10567:2007, they do not exceed 87% of hydraulic lifting capacity or 75% of tipping load. The load point is the center line of the bucket pivot mounting pin on the stick. The oscillating axle must be locked. Lifting capacities are based on the machine standing on a firm uniform supporting surface. For lifting capacity including bucket and/or quick coupler, the respective weight has to be subtracted from above values. The use of a work tool attachment point to handle/lift objects, could affect the machine lift performance.

Always refer to the appropriate Operation and Maintenance Manual for specific product information.

Lift Capacities (continued)

All values are in kg, bucket cylinder and linkage installed, hydraulic cab riser, work tool: none, with counterweight (4100 kg), heavy lift on.



Undercarriage

MH or Standard

Boom

6.8 m MH

Stick

4.8 m Straight Stick

Stick height	Undercarriage configuration	4500 mm			6000 mm			7500 mm			9000 mm			10 500 mm			mm		
		Load point height	Load over front	Load over rear	Load point height	Load over front	Load over rear	Load point height	Load over front	Load over rear	Load point height	Load over front	Load over rear	Load point height	Load over front	Load over rear			
3000 mm	MH – stabilizers up – solid tires	8300	8300	5900	5250	5250	3800	3700	3700	2650	2750	1900	2050	2050	1400	1750	1750	1150	
	MH – stabilizers down – solid tires	*14 100	*14 100	*14 100	*10 400	*10 400	8850	7750	7750	6150	5750	4550	4450	4450	3550	3900	3900	3050	
	Lower (std UC) – f. stabilizer & r. dozer up	8200	7600	5600	5150	4850	3600	3600	3400	2500	2500	1800	2000	1900	1300	1700	1600	1100	
	Lower (std UC) – f. stabilizer & r. dozer down	*14 100	*14 100	9300	*10 400	*10 400	5850	7300	7150	4100	5400	5300	3000	4150	4100	2300	3600	3550	2000
	Lower (std UC) – f. dozer & r. stabilizer up	8500	7300	5600	5350	4650	3600	3750	3250	2500	2750	2400	1800	2100	1800	1300	1800	1500	1100
	Lower (std UC) – f. dozer & r. stabilizer down	*14 100	*14 100	9650	*10 400	9050	6000	*8200	6200	4200	6100	4600	3100	4700	3550	2350	4100	3100	2050
1500 mm	MH – stabilizers up – solid tires	8450	7550	5650	5300	4800	3650	3700	3400	2500	2750	2500	1800	2050	1850	1300	1750	1600	1100
	MH – stabilizers down – solid tires	*14 100	*14 100	11 900	*10 400	9300	7300	7550	6400	5100	5550	4750	3750	4300	3650	2900	3750	3200	2500
	MH – stabilizers up – solid tires	7450	7450	5100	4850	4850	3400	3450	2400	2600	2600	1800	2000	2000	1350	1700	1700	1150	
	MH – stabilizers down – solid tires	*14 450	*14 450	13 750	*10 500	*10 500	8400	7500	7500	5900	5600	4400	4350	4350	3450	3800	3800	3000	
	Lower (std UC) – f. stabilizer & r. dozer up	7300	6750	4850	4750	4450	3200	3350	3200	2250	2500	2350	1650	1900	1800	1250	1650	1550	1050
	Lower (std UC) – f. stabilizer & r. dozer down	*14 450	*14 450	8400	10 300	10 000	5400	7050	6900	3850	5250	5150	2900	4100	4000	2250	3550	3500	1900
0 mm	Lower (std UC) – f. dozer & r. stabilizer up	7600	6500	4850	4950	4250	3200	3500	3050	2250	2600	2250	1650	2000	1700	1250	1750	1450	1050
	Lower (std UC) – f. dozer & r. stabilizer down	*14 450	14 200	8750	*10 500	8550	5600	8000	5950	3950	5950	4450	2950	4600	3450	2300	*4000	3000	2000
	Lower (std UC) – 2 sets stabilizers up	7550	6750	4900	4900	4400	3250	3500	3150	2300	2600	2350	1700	2000	1800	1250	1700	1550	1050
	Lower (std UC) – 2 sets stabilizers down	*14 450	*14 450	10 950	*10 500	8800	6850	7250	6150	4850	5400	4600	3650	4200	3600	2800	3650	3150	2450
	MH – stabilizers up – solid tires	6900	6900	4650	4550	4550	3100	3300	3300	2250	2500	2500	1700	1950	1950	1300			
	MH – stabilizers down – solid tires	*9550	*9550	*9550	*9900	*9900	8050	7250	7250	5700	5450	4300	4300	4300	3400				
-1500 mm	Lower (std UC) – f. stabilizer & r. dozer up	6800	6250	4350	4450	4150	2900	3200	3000	2100	2400	2250	1550	1850	1750	1200			
	Lower (std UC) – f. stabilizer & r. dozer down	*9550	*9550	7850	*9900	9600	5100	6850	6700	3650	5100	5000	2800	4000	3950	2200			
	Lower (std UC) – f. dozer & r. stabilizer up	7100	6000	4350	4600	3950	2900	3300	2850	2100	2500	2150	1550	1950	1650	1200			
	Lower (std UC) – f. dozer & r. stabilizer down	*9550	*9550	8200	*9900	8200	5250	*7650	5750	3900	5800	4350	2850	*4450	3400	2250			
	Lower (std UC) – 2 sets stabilizers up	7050	6250	4450	4600	4100	2950	3300	3000	2150	2500	2250	1600	1950	1750	1200			
	Lower (std UC) – 2 sets stabilizers down	*9550	*9550	*9550	*9900	8450	6500	7050	5950	4650	5250	4500	3500	4150	3550	2750			

*Limited by hydraulic rather than tipping load.

Lift capacity ratings are based on ISO 10567:2007, they do not exceed 87% of hydraulic lifting capacity or 75% of tipping load. The load point is the center line of the bucket pivot mounting pin on the stick. The oscillating axle must be locked. Lifting capacities are based on the machine standing on a firm uniform supporting surface. For lifting capacity including bucket and/or quick coupler, the respective weight has to be subtracted from above values. The use of a work tool attachment point to handle/lift objects, could affect the machine lift performance.

Always refer to the appropriate Operation and Maintenance Manual for specific product information.

















Material Handlers

Lifting Capacities

- MH3024 (Grenoble Sourced)

Lift Capacities

All values are in lb, bucket cylinder and linkage installed, hydraulic cab riser, work tool: none, with counterweight (9040 lb), heavy lift on.

	 Load point height	 Load over front	 Load over rear	 Load over side	 Load at maximum reach (sticknose/bucket pin)										
	Undercarriage		Boom			Stick									
	MH or Standard		22'4" MH			15'9" Straight Stick									
			15 ft		20 ft		25 ft		30 ft		35 ft				
	Undercarriage configuration												ft		
40 ft	MH – stabilizers up – solid tires														
	MH – stabilizers down – solid tires														
	Lower (std UC) – f. stabilizer & r. dozer up														
	Lower (std UC) – f. stabilizer & r. dozer down														
	Lower (std UC) – f. dozer & r. stabilizer up														
	Lower (std UC) – f. dozer & r. stabilizer down														
	Lower (std UC) – 2 sets stabilizers up														
35 ft	MH – stabilizers up – solid tires				13,100	13,100	9800						9700	9700	7200
	MH – stabilizers down – solid tires														
	Lower (std UC) – f. stabilizer & r. dozer up														
	Lower (std UC) – f. stabilizer & r. dozer down														
	Lower (std UC) – f. dozer & r. stabilizer up														
	Lower (std UC) – f. dozer & r. stabilizer down														
	Lower (std UC) – 2 sets stabilizers down														
30 ft	MH – stabilizers up – solid tires														
	MH – stabilizers down – solid tires														
	Lower (std UC) – f. stabilizer & r. dozer up														
	Lower (std UC) – f. stabilizer & r. dozer down														
	Lower (std UC) – f. dozer & r. stabilizer up														
	Lower (std UC) – f. dozer & r. stabilizer down														
	Lower (std UC) – 2 sets stabilizers up														
25 ft	MH – stabilizers up – solid tires														
	MH – stabilizers down – solid tires														
	Lower (std UC) – f. stabilizer & r. dozer up														
	Lower (std UC) – f. stabilizer & r. dozer down														
	Lower (std UC) – f. dozer & r. stabilizer up														
	Lower (std UC) – f. dozer & r. stabilizer down														
	Lower (std UC) – 2 sets stabilizers down														
20 ft	MH – stabilizers up – solid tires														
	MH – stabilizers down – solid tires														
	Lower (std UC) – f. stabilizer & r. dozer up														
	Lower (std UC) – f. stabilizer & r. dozer down														
	Lower (std UC) – f. dozer & r. stabilizer up														
	Lower (std UC) – f. dozer & r. stabilizer down														
	Lower (std UC) – 2 sets stabilizers up														
15 ft	MH – stabilizers up – solid tires														
	MH – stabilizers down – solid tires														
	Lower (std UC) – f. stabilizer & r. dozer up														
	Lower (std UC) – f. stabilizer & r. dozer down														
	Lower (std UC) – f. dozer & r. stabilizer up														
	Lower (std UC) – f. dozer & r. stabilizer down														
	Lower (std UC) – 2 sets stabilizers down														

*Limited by hydraulic rather than tipping load.

(continued on next page)

Lift capacity ratings are based on ISO 10567:2007, they do not exceed 87% of hydraulic lifting capacity or 75% of tipping load. The load point is the center line of the bucket pivot mounting pin on the stick. The oscillating axle must be locked. Lifting capacities are based on the machine standing on a firm uniform supporting surface. For lifting capacity including bucket and/or quick coupler, the respective weight has to be subtracted from above values. The use of a work tool attachment point to handle/lift objects, could affect the machine lift performance.

Always refer to the appropriate Operation and Maintenance Manual for specific product information.

Lift Capacities (continued)

All values are in lb, bucket cylinder and linkage installed, hydraulic cab riser, work tool: none, with counterweight (9040 lb), heavy lift on.

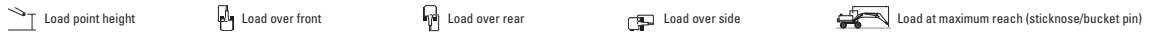

Undercarriage

Boom
22" MH

Stick
15'9" Straight Stick

MH or Standard

Stick ft	Undercarriage configuration	15 ft			20 ft			25 ft			30 ft			35 ft			ft			
		Load point height	Load over front	Load over rear	Load point height	Load over front	Load over rear	Load point height	Load over front	Load over rear	Load point height	Load over front	Load over rear	Load point height	Load over front	Load over rear				
10 ft	MH – stabilizers up – solid tires	17,900	17,900	12,700	11,400	11,400	8200	8000	8000	5700	5900	5900	4100	4400	4400	3000	3900	3900	2600	37.30
	MH – stabilizers down – solid tires	*30,500	*30,500	*30,500	*22,500	*22,500	19,100	16,700	16,700	13,200	12,300	12,300	9800	9500	9500	7600	8600	8600	6800	
	Lower (std UC) – f. stabilizer & r. dozer up	17,700	16,400	12,100	11,100	10,500	7700	7700	7300	5300	5700	5400	3800	4200	4000	2800	3700	3500	2400	
	Lower (std UC) – f. stabilizer & r. dozer down	*30,500	*30,500	20,100	*22,500	22,500	12,600	15,700	15,400	8800	11,600	11,400	6500	8900	8800	4900	8000	7900	4400	
	Lower (std UC) – f. dozer & r. stabilizer up	18,300	15,800	12,100	11,500	10,100	7700	8000	7000	5300	5900	5100	3800	4500	3800	2800	3900	3300	2400	
	Lower (std UC) – f. dozer & r. stabilizer down	*30,500	*30,500	20,800	*22,500	19,400	13,000	17,800	13,300	9000	13,100	9900	6700	10,100	7600	5100	9000	6800	4500	
5 ft	Lower (std UC) – 2 sets stabilizers up	18,200	16,300	12,300	11,400	10,400	7800	8000	7300	5400	5900	3900	4400	4000	2800	3900	3500	2400		
	Lower (std UC) – 2 sets stabilizers down	*30,500	*30,500	25,600	*22,500	20,000	15,700	16,200	13,800	10,900	11,900	10,200	8100	9200	7900	6200	8200	7100	5500	
	MH – stabilizers up – solid tires	16,000	16,000	11,000	10,500	10,500	7300	7500	7500	5200	5600	5600	3800	4300	4300	2900	3800	3800	2500	37.50
	MH – stabilizers down – solid tires	*31,300	*31,300	29,400	*22,800	*22,800	18,100	16,100	16,100	12,700	12,000	12,000	9500	9400	9400	7400	8400	8400	6600	
	Lower (std UC) – f. stabilizer & r. dozer up	15,800	14,600	10,400	10,200	9600	6900	7200	6800	4900	5400	5100	3600	4100	3900	2600	3600	3400	2300	
	Lower (std UC) – f. stabilizer & r. dozer down	*31,300	*31,300	18,100	22,100	21,400	11,700	15,200	14,800	8300	11,300	11,100	6200	8800	8600	4800	7800	7700	4200	
Lower (std UC) – f. dozer & r. stabilizer up	16,400	14,000	10,400	10,600	9200	6900	7600	6500	4900	5600	4800	3600	4300	3700	2600	3800	3200	2200		
Lower (std UC) – f. dozer & r. stabilizer down	*31,300	30,400	18,800	*22,800	18,400	12,000	17,200	12,800	8500	12,700	9600	6400	9900	7500	4900	*8800	6700	4400		
0 ft	Lower (std UC) – 2 sets stabilizers up	16,300	14,500	10,600	10,600	9500	7000	7500	6800	5000	5600	5100	3600	4300	3900	2700	3800	3400	2300	
	Lower (std UC) – 2 sets stabilizers down	*31,300	*31,300	23,500	22,800	19,000	14,700	15,600	13,200	10,400	11,600	9900	7800	9000	7700	6100	8100	6900	5400	
	MH – stabilizers up – solid tires	14,900	14,900	10,000	9800	9800	6700	7100	7100	4800	5400	5400	3600	4200	4200	2800	3800	3800	2500	37.50
	MH – stabilizers down – solid tires	*22,400	*22,400	*22,400	*21,500	*21,500	17,300	15,600	15,600	12,200	11,800	11,800	9300	9300	9300	7300				
	Lower (std UC) – f. stabilizer & r. dozer up	14,600	13,500	9400	9500	8900	6300	6800	6500	4500	5200	4900	3300	4000	3800	2500				
	Lower (std UC) – f. stabilizer & r. dozer down	*22,400	*22,400	16,900	21,300	20,600	11,000	14,700	14,400	7900	11,000	10,800	6000	8600	8500	4700				
Lower (std UC) – f. dozer & r. stabilizer up	15,200	12,900	9400	10,000	8500	6300	7200	6100	4500	5400	4600	3300	4200	3600	2500					
Lower (std UC) – f. dozer & r. stabilizer down	*22,400	*22,400	17,600	*21,500	17,600	11,300	*16,600	12,400	8100	12,500	9300	6100	*9400	7300	4800					
-5 ft	Lower (std UC) – 2 sets stabilizers up	15,100	13,400	9500	9900	8900	6400	7100	6400	4600	5400	4800	3400	4200	3800	2600				
	Lower (std UC) – 2 sets stabilizers down	*22,400	*22,400	22,200	*21,500	18,200	14,000	15,100	12,800	10,000	11,300	9700	7600	8900	7600	6000				
	MH – stabilizers up – solid tires				9500	9500	6400	6800	6800	4600										
	MH – stabilizers down – solid tires				*18,300	*18,300	16,900	*14,200	*14,200	12,900										
	Lower (std UC) – f. stabilizer & r. dozer up				9200	8600	6000	6600	6200	4300										
	Lower (std UC) – f. stabilizer & r. dozer down				*18,300	*18,300	10,600	*14,200	14,100	7600										

*Limited by hydraulic rather than tipping load.

Lift capacity ratings are based on ISO 10567:2007, they do not exceed 87% of hydraulic lifting capacity or 75% of tipping load. The load point is the center line of the bucket pivot mounting pin on the stick. The oscillating axle must be locked. Lifting capacities are based on the machine standing on a firm uniform supporting surface. For lifting capacity including bucket and/or quick coupler, the respective weight has to be subtracted from above values. The use of a work tool attachment point to handle/lift objects, could affect the machine lift performance.

Always refer to the appropriate Operation and Maintenance Manual for specific product information.

Lift Capacities

All values are in kg, bucket cylinder and linkage installed, hydraulic cab riser, work tool: none, with counterweight (5200 kg), heavy lift on.

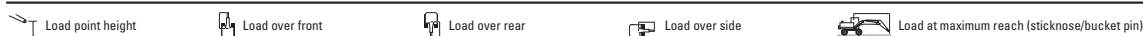

Undercarriage

MH or Standard

Boom

6.8 m MH

Stick

4.8 m Straight Stick

Load point height	Undercarriage configuration	4500 mm			6000 mm			7500 mm			9000 mm			10 500 mm			mm		
		Load over front	Load over rear	Load over side	Load over front	Load over rear	Load over side	Load over front	Load over rear	Load over side	Load over front	Load over rear	Load over side	Load over front	Load over rear	Load over side			
12 000 mm	MH – stabilizers up – solid tires	*8800	*8800	7900													*7750	*7750	6700
	MH – stabilizers down – solid tires	*8800	*8800	*8800													*7750	*7750	*7750
	Lower (std UC) – f. stabilizer & r. dozer up	*8800	*8800	7600													*7750	*7750	6450
	Lower (std UC) – f. stabilizer & r. dozer down	*8800	*8800	*8800													*7750	*7750	*7750
	Lower (std UC) – f. dozer & r. stabilizer up	*8800	*8800	7600													*7750	*7750	6450
	Lower (std UC) – f. dozer & r. stabilizer down	*8800	*8800	*8800													*7750	*7750	*7750
	Lower (std UC) – 2 sets stabilizers up	*8800	*8800	7700													*7750	*7750	6500
Lower (std UC) – 2 sets stabilizers down	*8800	*8800	*8800													*7750	*7750	*7750	
10 500 mm	MH – stabilizers up – solid tires				6800	6800	5150										4750	4750	3550
	MH – stabilizers down – solid tires				*8850	*8850	*8850										*6150	*6150	*6150
	Lower (std UC) – f. stabilizer & r. dozer up				6750	6350	4950										4650	4400	3400
	Lower (std UC) – f. stabilizer & r. dozer down				*8850	*8850	7450										*6150	*6150	5200
	Lower (std UC) – f. dozer & r. stabilizer up				6900	6150	4950										4800	4250	3400
	Lower (std UC) – f. dozer & r. stabilizer down				*8850	*8850	7650										*6150	*6150	5300
	Lower (std UC) – 2 sets stabilizers up				6900	6300	5000										4750	4400	3450
Lower (std UC) – 2 sets stabilizers down				*8850	*8850	*8850										*6150	*6150	*6150	
9000 mm	MH – stabilizers up – solid tires				6950	6950	5300	4700	4700	3550							3450	3450	2550
	MH – stabilizers down – solid tires				*9000	*9000	*9000	*7700	*7700	7350							*5550	*5550	5450
	Lower (std UC) – f. stabilizer & r. dozer up				6850	6450	5100	4650	4400	3400							3350	3200	2400
	Lower (std UC) – f. stabilizer & r. dozer down				*9000	*9000	7600	*7700	*7700	5150							*5550	*5550	3800
	Lower (std UC) – f. dozer & r. stabilizer up				7050	6250	5100	4800	4250	3400							3500	3100	2400
	Lower (std UC) – f. dozer & r. stabilizer down				*9000	*9000	7800	*7700	7500	5300							*5550	5500	3850
	Lower (std UC) – 2 sets stabilizers up				7000	6450	5150	4750	4400	3450							3450	3200	2450
Lower (std UC) – 2 sets stabilizers down				*9000	*9000	*9000	*7700	7650	6250							*5550	*5550	4800	
7500 mm	MH – stabilizers up – solid tires				6900	6900	5250	4700	4700	3550	3400	3400	2500				2800	2800	2050
	MH – stabilizers down – solid tires				*9050	*9050	*9050	*7700	*7700	7350	6600	6600	5350				*5200	*5200	4500
	Lower (std UC) – f. stabilizer & r. dozer up				6800	6400	5050	4650	4400	3400	3300	3150	2400				2750	2600	1950
	Lower (std UC) – f. stabilizer & r. dozer down				*9050	*9050	7550	*7700	*7700	5150	6300	6150	3700				*5200	5150	3100
	Lower (std UC) – f. dozer & r. stabilizer up				7000	6250	5050	4800	4250	3400	3450	3050	2400				2850	2500	1950
	Lower (std UC) – f. dozer & r. stabilizer down				*9050	*9050	7750	*7700	7450	5300	*6650	5400	3800				*5200	4550	3150
	Lower (std UC) – 2 sets stabilizers up				6950	6400	5100	4750	4350	3450	3400	3150	2450				2800	2600	1950
Lower (std UC) – 2 sets stabilizers down				*9050	*9050	*9050	*7700	7650	6250	6450	5550	4500				*5200	4650	3750	
6000 mm	MH – stabilizers up – solid tires				*9400	*9400	5950	4600	4600	3450	3350	3350	2500	2500	1800		2450	2450	1750
	MH – stabilizers down – solid tires				*9400	*9400	*9400	*7850	*7850	7250	6600	6600	5300	5050	4050		4900	4900	3950
	Lower (std UC) – f. stabilizer & r. dozer up				6600	6250	4850	4550	4300	3300	3300	3100	2350	2450	2300		1700	2250	1650
	Lower (std UC) – f. stabilizer & r. dozer down				*9400	*9400	7350	*7850	*7850	5050	6250	6100	3700	4750	4650		2750	4650	2700
	Lower (std UC) – f. dozer & r. stabilizer up				6800	6050	4850	4700	4150	3300	3400	3000	2350	2550	2200		1700	2450	1650
	Lower (std UC) – f. dozer & r. stabilizer down				*9400	*9400	7550	*7850	7350	5200	*6650	5400	3800	5300	4100		*5100	4100	2750
	Lower (std UC) – 2 sets stabilizers up				6750	6200	4900	4650	4250	3350	3400	3100	2400	2500	2300		1700	2450	1650
Lower (std UC) – 2 sets stabilizers down				*9400	*9400	8950	*7850	7550	6100	6400	5550	4500	4850	4200		3400	4750	4100	
4500 mm	MH – stabilizers up – solid tires	10 200	10 200	7550	6350	6350	4750	4450	4450	3300	3250	3250	2400	2500	2500	1750	2200	2200	1550
	MH – stabilizers down – solid tires	*12 850	*12 850	*12 850	*9900	*9900	*9900	*8050	*8050	7050	6450	6450	5200	5000	5000	4050	4550	4550	3850
	Lower (std UC) – f. stabilizer & r. dozer up	10 150	9450	7250	6300	5900	4550	4350	4100	3150	3200	3000	2250	2400	2300	1650	2150	2050	1450
	Lower (std UC) – f. stabilizer & r. dozer down	*12 850	*12 850	11 350	*9900	*9900	7000	*8050	*8050	4850	6150	6000	3600	4700	4650		2750	4250	2400
	Lower (std UC) – f. dozer & r. stabilizer up	10 450	9150	7250	6500	5750	4550	4500	4000	3150	3300	2900	2250	2500	2200	1650	2250	1950	1450
	Lower (std UC) – f. dozer & r. stabilizer down	*12 850	*12 850	11 750	*9900	*9900	7200	*8050	7150	5000	*6700	5300	3700	5300	4050	2800	4800	3650	2500
	Lower (std UC) – 2 sets stabilizers up	10 400	9400	7300	6450	5900	4600	4450	4100	3200	3300	3000	2300	2500	2250	1700	2200	2000	1500
Lower (std UC) – 2 sets stabilizers down	*12 850	*12 850	*12 850	*9900	*9900	8600	*8050	7350	5950	6300	5450	4400	4850	4200	3350	4400	3800	3050	

* Limited by hydraulic rather than tipping load.

(continued on next page)

Lift capacity ratings are based on ISO 10567:2007, they do not exceed 87% of hydraulic lifting capacity or 75% of tipping load. The load point is the center line of the bucket pivot mounting pin on the stick. The oscillating axle must be locked. Lifting capacities are based on the machine standing on a firm uniform supporting surface. For lifting capacity including bucket and/or quick coupler, the respective weight has to be subtracted from above values. The use of a work tool attachment point to handle/lift objects, could affect the machine lift performance.

Always refer to the appropriate Operation and Maintenance Manual for specific product information.

Lift Capacities (continued)

All values are in kg, bucket cylinder and linkage installed, hydraulic cab riser, work tool: none, with counterweight (5200 kg), heavy lift on.



Undercarriage

MH or Standard

Boom

6.8 m MH

Stick

4.8 m Straight Stick

Load point height	Undercarriage configuration	4500 mm			6000 mm			7500 mm			9000 mm			10 500 mm			mm		
		Load over front	Load over rear	Load over side	Load over front	Load over rear	Load over side	Load over front	Load over rear	Load over side	Load over front	Load over rear	Load over side	Load at maximum reach (sticknose/bucket pin)					
3000 mm	MH – stabilizers up – solid tires	9300	9300	6750	5950	5950	4400	4200	4200	3100	3150	3150	2250	2400	2400	1700	2100	2100	1450
	MH – stabilizers down – solid tires	*14 100	*14 100	*14 100	*10 400	*10 400	9800	*8200	*8200	6800	6350	6350	5100	4950	4950	3950	4300	4300	3450
	Lower (std UC) – f. stabilizer & r. dozer up	9250	8550	6450	5850	5500	4200	4100	3900	2950	3050	2900	2150	2350	2200	1600	2000	1900	1350
	Lower (std UC) – f. stabilizer & r. dozer down	*14 100	*14 100	10 450	*10 400	*10 400	6600	8100	7900	4650	6000	5850	3450	4650	4550	2650	4050	4000	2300
	Lower (std UC) – f. dozer & r. stabilizer up	9550	8300	6450	6050	5300	4200	4250	3750	2950	3200	2800	2150	2450	2100	1600	2100	1800	1350
	Lower (std UC) – f. dozer & r. stabilizer down	*14 100	*14 100	10 800	*10 400	10 000	6800	*8200	6900	4750	*6700	5150	3550	5200	4000	2750	*4500	3500	2350
1500 mm	Lower (std UC) – 2 sets stabilizers up	9500	8550	6500	6000	5500	4250	4250	3900	2950	3150	2900	2200	2400	2200	1650	2100	1900	1400
	Lower (std UC) – 2 sets stabilizers down	*14 100	*14 100	13 250	*10 400	10 300	8150	*8200	7100	5700	6150	5300	4250	4750	4100	3300	4200	3600	2850
	MH – stabilizers up – solid tires	8450	8450	5950	5550	5550	4000	4000	4000	2900	3000	3000	2150	2350	2350	1650	2050	2050	1400
	MH – stabilizers down – solid tires	*14 450	*14 450	*14 450	*10 500	*10 500	9300	*8150	*8150	6550	6200	6200	4950	4850	4850	3900	*4000	*4000	3400
	Lower (std UC) – f. stabilizer & r. dozer up	8400	7750	5650	5450	5100	3800	3900	3700	2750	2950	2800	2050	2300	2150	1550	1950	1850	1300
	Lower (std UC) – f. stabilizer & r. dozer down	*14 450	*14 450	9550	*10 500	*10 500	6150	7850	7650	4400	5850	5700	3350	4550	4500	2600	4000	3950	2250
0 mm	Lower (std UC) – f. dozer & r. stabilizer up	8650	7450	5650	5650	4900	3800	4050	3550	2750	3050	2650	2050	2350	2050	1550	2050	1750	1300
	Lower (std UC) – f. dozer & r. stabilizer down	*14 450	*14 450	9900	*10 500	9500	6350	*8150	6650	4550	*6500	5000	3400	*5100	3900	2650	*4000	3450	2300
	Lower (std UC) – 2 sets stabilizers up	8600	7700	5750	5600	5100	3850	4000	3650	2750	3050	2750	2050	2350	2150	1550	2050	1850	1350
	Lower (std UC) – 2 sets stabilizers down	*14 450	*14 450	12 250	*10 500	9800	7700	8050	6850	5450	6000	5150	4100	4700	4050	3250	*4000	3550	2800
	MH – stabilizers up – solid tires	7950	7950	5500	5250	5250	3700	3800	3800	2700	2900	2900	2050	2300	2300	1600	2050	2050	1400
	MH – stabilizers down – solid tires	*9550	*9550	*9550	*9900	*9900	8950	*7650	*7650	6350	*6000	*6000	4850	*4450	*4450	3850			
-1500 mm	Lower (std UC) – f. stabilizer & r. dozer up	7850	7250	5200	5150	4800	3500	3700	3500	2550	2850	2650	1950	2200	2100	1500			
	Lower (std UC) – f. stabilizer & r. dozer down	*9550	*9550	9000	*9900	*9900	5850	7600	7400	4200	5700	5600	3200	*4450	4450	2550			
	Lower (std UC) – f. dozer & r. stabilizer up	8150	6950	5200	5350	4600	3500	3850	3350	2550	2950	2550	1950	2300	2000	1500			
	Lower (std UC) – f. dozer & r. stabilizer down	*9550	*9550	9350	*9900	9150	6050	*7650	6450	4350	*6000	4900	3300	*4450	3850	2600			
	Lower (std UC) – 2 sets stabilizers up	8100	7200	5250	5300	4800	3550	3850	3500	2600	2900	2650	1950	2300	2100	1500			
	Lower (std UC) – 2 sets stabilizers down	*9550	*9550	*9550	*9900	9450	7350	*7650	6650	5250	5900	5050	4000	*4450	4000	3150			

*Limited by hydraulic rather than tipping load.

Lift capacity ratings are based on ISO 10567:2007, they do not exceed 87% of hydraulic lifting capacity or 75% of tipping load. The load point is the center line of the bucket pivot mounting pin on the stick. The oscillating axle must be locked. Lifting capacities are based on the machine standing on a firm uniform supporting surface. For lifting capacity including bucket and/or quick coupler, the respective weight has to be subtracted from above values. The use of a work tool attachment point to handle/lift objects, could affect the machine lift performance.

Always refer to the appropriate Operation and Maintenance Manual for specific product information.

Lift Capacities

All values are in lb, bucket cylinder and linkage installed, hydraulic cab riser, work tool: none, with counterweight (11,470 lb), heavy lift on.

		Load point height	Load over front	Load over rear	Load over side	Load at maximum reach (sticknose/bucket pin)													
Undercarriage		Boom						Stick											
MH or Standard		22'4" MH						15'9" Straight Stick											
	Undercarriage configuration	15 ft			20 ft			25 ft			30 ft			35 ft			ft		
40 ft	MH – stabilizers up – solid tires																*18,000	*18,000	17,000
	MH – stabilizers down – solid tires																*18,000	*18,000	*18,000
	Lower (std UC) – f. stabilizer & r. dozer up																*18,000	*18,000	16,400
	Lower (std UC) – f. stabilizer & r. dozer down																*18,000	*18,000	*18,000
	Lower (std UC) – f. dozer & r. stabilizer up																*18,000	*18,000	16,400
	Lower (std UC) – f. dozer & r. stabilizer down																*18,000	*18,000	*18,000
	Lower (std UC) – 2 sets stabilizers up																*18,000	*18,000	16,500
Lower (std UC) – 2 sets stabilizers down																*18,000	*18,000	*18,000	
35 ft	MH – stabilizers up – solid tires				14,500	14,500	11,000										10,900	10,900	8200
	MH – stabilizers down – solid tires				*18,800	*18,800	*18,800										*13,800	*13,800	*13,800
	Lower (std UC) – f. stabilizer & r. dozer up				14,400	13,600	10,600										10,800	10,200	7900
	Lower (std UC) – f. stabilizer & r. dozer down				*18,800	*18,800	15,900										*13,800	*13,800	12,000
	Lower (std UC) – f. dozer & r. stabilizer up				14,800	13,100	10,300										11,100	9800	7900
	Lower (std UC) – f. dozer & r. stabilizer down				*18,800	*18,800	16,400										*13,800	*13,800	12,300
	Lower (std UC) – 2 sets stabilizers up				14,700	13,500	10,700										11,000	10,100	8000
Lower (std UC) – 2 sets stabilizers down				*18,800	*18,800	*18,800										*13,800	*13,800	*13,800	
30 ft	MH – stabilizers up – solid tires				14,900	14,900	11,300	10,100	10,100	7600							7800	7800	5800
	MH – stabilizers down – solid tires				*19,600	*19,600	*19,600	*16,800	*16,800	15,800							*12,300	*12,300	*12,300
	Lower (std UC) – f. stabilizer & r. dozer up				14,700	13,900	10,900	9900	9400	7300							7600	7200	5500
	Lower (std UC) – f. stabilizer & r. dozer down				*19,600	*19,600	16,300	*16,800	*16,800	11,000							*12,300	*12,300	8500
	Lower (std UC) – f. dozer & r. stabilizer up				15,100	13,500	10,900	10,200	9100	7300							7900	7000	5500
	Lower (std UC) – f. dozer & r. stabilizer down				*19,600	*19,600	16,700	*16,800	16,000	11,300							*12,300	*12,300	8700
	Lower (std UC) – 2 sets stabilizers up				15,000	13,800	11,000	10,200	9400	7400							7800	7200	5600
Lower (std UC) – 2 sets stabilizers down				*19,600	*19,600	*19,600	*16,800	16,400	13,400							*12,300	*12,300	10,400	
25 ft	MH – stabilizers up – solid tires				14,800	14,800	11,300	10,100	10,100	7600	7300	7300	5400				6300	6300	4600
	MH – stabilizers down – solid tires				*19,700	*19,700	*19,700	*16,700	*16,700	15,800	14,200	14,200	11,500				*11,600	*11,600	10,000
	Lower (std UC) – f. stabilizer & r. dozer up				14,600	13,800	10,800	9900	9400	7300	7100	6700	5100				6100	5800	4300
	Lower (std UC) – f. stabilizer & r. dozer down				*19,700	*19,700	16,200	*16,700	*16,700	11,100	13,500	13,200	8000				*11,600	11,500	6900
	Lower (std UC) – f. dozer & r. stabilizer up				15,000	13,400	10,800	10,300	9100	7300	7400	6500	5100				6300	5600	4300
	Lower (std UC) – f. dozer & r. stabilizer down				*19,700	*19,700	16,600	*16,700	16,000	11,300	*14,400	11,600	8200				*11,600	10,100	7100
	Lower (std UC) – 2 sets stabilizers up				15,000	13,700	10,900	10,200	9400	7400	7300	6700	5200				6300	5800	4400
Lower (std UC) – 2 sets stabilizers down				*19,700	*19,700	19,700	*16,700	16,500	13,400	13,800	11,900	9700				*11,600	10,400	8400	
20 ft	MH – stabilizers up – solid tires				14,400	14,400	10,900	9900	9900	7500	7200	7200	5300				5400	5400	3900
	MH – stabilizers down – solid tires				*20,400	*20,400	*20,400	*17,000	*17,000	15,600	14,100	14,100	11,400				10,900	10,900	8800
	Lower (std UC) – f. stabilizer & r. dozer up				14,200	13,400	10,500	9700	9200	7100	7000	6700	5100				5300	5000	3600
	Lower (std UC) – f. stabilizer & r. dozer down				*20,400	*20,400	15,800	*17,000	*17,000	10,900	13,400	13,100	7900				10,300	10,100	6000
	Lower (std UC) – f. dozer & r. stabilizer up				14,600	13,000	10,500	10,100	8900	7100	7300	6400	5100				5500	4800	3600
	Lower (std UC) – f. dozer & r. stabilizer down				*20,400	*20,400	16,200	*17,000	15,800	11,100	*14,500	11,500	8100				*11,300	8900	6100
	Lower (std UC) – 2 sets stabilizers up				14,600	13,400	10,600	10,000	9200	7200	7200	6600	5100				5400	5000	3700
Lower (std UC) – 2 sets stabilizers down				*20,400	*20,400	19,200	*17,000	16,200	13,200	13,700	11,900	9600				10,600	9100	7200	
15 ft	MH – stabilizers up – solid tires	22,000	22,000	16,300	13,700	13,700	10,300	9600	9600	7100	7000	7000	5100	5300	5300	3800	4900	4900	3400
	MH – stabilizers down – solid tires	*27,800	*27,800	*27,800	*21,500	*21,500	*21,500	*17,500	*17,500	15,200	13,900	13,900	11,200	10,700	10,700	8600	10,000	10,000	8100
	Lower (std UC) – f. stabilizer & r. dozer up	21,900	20,400	15,700	13,500	12,800	9800	9400	8900	6800	6800	6500	4900	5100	4900	3600	4700	4500	3200
	Lower (std UC) – f. stabilizer & r. dozer down	*27,800	*27,800	24,400	*21,500	*21,500	15,100	*17,500	*17,500	10,500	13,200	12,900	7700	10,100	9900	5800	9400	9300	5400
	Lower (std UC) – f. dozer & r. stabilizer up	22,500	19,800	15,700	14,000	12,400	9800	9700	8600	6800	7100	6200	4900	5400	4700	3600	4900	4300	3200
	Lower (std UC) – f. dozer & r. stabilizer down	*27,800	*27,800	25,300	*21,500	*21,500	15,500	*17,500	15,400	10,700	*14,500	11,300	7900	11,300	8700	6000	10,600	8100	6000
	Lower (std UC) – 2 sets stabilizers up	22,400	20,300	15,800	13,900	12,700	10,000	9600	8800	6900	7100	6500	4900	5300	4800	3600	4900	4500	3300
Lower (std UC) – 2 sets stabilizers down	*27,800	*27,800	*27,800	*21,500	*21,500	18,500	*17,500	15,800	12,800	13,500	11,700	9400	10,400	9000	7200	8700	8400	6700	

*Limited by hydraulic rather than tipping load.

(continued on next page)

Lift capacity ratings are based on ISO 10567:2007, they do not exceed 87% of hydraulic lifting capacity or 75% of tipping load. The load point is the center line of the bucket pivot mounting pin on the stick. The oscillating axle must be locked. Lifting capacities are based on the machine standing on a firm uniform supporting surface. For lifting capacity including bucket and/or quick coupler, the respective weight has to be subtracted from above values. The use of a work tool attachment point to handle/lift objects, could affect the machine lift performance.

Always refer to the appropriate Operation and Maintenance Manual for specific product information.

Lift Capacities (continued)

All values are in lb, bucket cylinder and linkage installed, hydraulic cab riser, work tool: none, with counterweight (11,470 lb), heavy lift on.



Undercarriage

Boom
22" MH

Stick

MH or Standard

15'9" Straight Stick

Stick ft	Undercarriage configuration	15 ft			20 ft			25 ft			30 ft			35 ft			ft		
		Load point height	Load over front	Load over rear	Load over front	Load over rear	Load over side	Load over front	Load over rear	Load over side	Load over front	Load over rear	Load over side	Load over front	Load over rear	Load over side			
10 ft	MH – stabilizers up – solid tires	20,100	20,100	14,500	12,900	12,900	9400	9100	6700	6800	6800	4900	5200	5200	3700	4600	4600	3200	
	MH – stabilizers down – solid tires	*30,500	*30,500	*30,500	*22,500	*22,500	21,100	*17,800	*17,800	14,600	13,600	13,600	10,900	10,600	8500	9500	9500	7700	
	Lower (std UC) – f. stabilizer & r. dozer up	19,900	18,500	13,900	12,600	11,900	9000	8900	8400	6300	6600	6200	4600	5000	4800	3400	4500	4200	3000
	Lower (std UC) – f. stabilizer & r. dozer down	*30,500	*30,500	22,500	*22,500	*22,500	14,200	17,400	17,000	10,000	12,900	12,600	7400	10,000	9800	5700	9000	8800	5100
	Lower (std UC) – f. dozer & r. stabilizer up	20,600	17,900	13,900	13,100	11,500	9000	9200	8100	6300	6800	6000	4600	5200	4600	3400	4700	4000	3000
	Lower (std UC) – f. dozer & r. stabilizer down	*30,500	*30,500	23,200	*22,500	21,500	14,600	*17,800	14,900	10,300	14,400	11,100	7600	11,200	8600	5900	*10,000	7700	5200
5 ft	Lower (std UC) – 2 sets stabilizers up	20,500	18,400	14,100	13,000	11,800	9100	9100	8400	6400	6800	6200	4700	5200	4700	3500	4600	4200	3000
	Lower (std UC) – 2 sets stabilizers down	*30,500	*30,500	28,400	*22,500	22,100	17,500	*17,800	15,300	12,300	13,200	11,400	9100	10,300	8800	7100	9200	8000	6300
	MH – stabilizers up – solid tires	18,200	18,200	12,900	12,000	12,000	8600	8600	8600	6200	6500	6500	4600	5100	5100	3500	4500	4500	3100
	MH – stabilizers down – solid tires	*31,300	*31,300	*31,300	*22,800	*22,800	20,000	*17,600	*17,600	14,100	13,300	13,300	10,600	10,400	8400	*8800	*8800	7500	
	Lower (std UC) – f. stabilizer & r. dozer up	18,100	16,700	12,300	11,700	11,000	8200	8400	7900	5900	6300	6000	4400	4900	4600	3300	4300	4100	2900
	Lower (std UC) – f. stabilizer & r. dozer down	*31,300	*31,300	20,500	*22,800	*22,800	13,300	16,800	16,400	9500	12,600	12,300	7200	9800	9700	5600	8800	8700	5000
0 ft	Lower (std UC) – f. dozer & r. stabilizer up	18,700	16,100	12,300	12,200	10,600	8200	8700	7600	5900	6600	5700	4400	5100	4400	3300	4500	3900	2900
	Lower (std UC) – f. dozer & r. stabilizer down	*31,300	*31,300	21,300	*22,800	20,500	13,700	*17,600	14,300	9800	*14,000	10,800	7400	*10,800	8400	5700	*8800	7600	5100
	Lower (std UC) – 2 sets stabilizers up	18,600	16,600	12,400	12,100	11,000	8300	8700	7900	5900	6500	5900	4400	5100	4600	3400	4500	4100	2900
	Lower (std UC) – 2 sets stabilizers down	*31,300	*31,300	26,300	*22,800	21,000	16,600	17,300	14,700	11,700	12,900	11,100	8900	10,100	8700	6900	*8800	7800	6200
	MH – stabilizers up – solid tires	17,100	17,100	11,800	11,300	11,300	8000	8200	8200	5800	6300	6300	4400	4900	4900	3400			
	MH – stabilizers down – solid tires	*22,400	*22,400	*22,400	*21,500	*21,500	19,300	*16,600	*16,600	13,700	*12,900	*12,900	10,400	*9400	*9400	8300			
-5 ft	Lower (std UC) – f. stabilizer & r. dozer up	16,900	15,600	11,200	11,100	10,400	7600	8000	7500	5500	6100	5700	4100	4800	4500	3200			
	Lower (std UC) – f. stabilizer & r. dozer down	*22,400	*22,400	19,300	*21,500	*21,500	12,600	16,400	16,000	9100	12,300	12,100	6900	*9400	*9400	5500			
	Lower (std UC) – f. dozer & r. stabilizer up	17,500	15,000	11,200	11,500	10,000	7600	8300	7200	5500	6300	5500	4100	5000	4300	3200			
	Lower (std UC) – f. dozer & r. stabilizer down	*22,400	*22,400	20,100	*21,500	19,700	13,000	*16,600	13,900	9400	*12,900	10,500	7100	*9400	8300	5600			
	Lower (std UC) – 2 sets stabilizers up	17,400	15,500	11,400	11,400	10,300	7700	8300	7500	5600	6300	5700	4200	5000	4500	3300			
	Lower (std UC) – 2 sets stabilizers down	*22,400	*22,400	*22,400	*21,500	20,300	15,800	*16,600	14,300	11,300	12,600	10,800	8600	*9400	8600	6800			

*Limited by hydraulic rather than tipping load.

Lift capacity ratings are based on ISO 10567:2007, they do not exceed 87% of hydraulic lifting capacity or 75% of tipping load. The load point is the center line of the bucket pivot mounting pin on the stick. The oscillating axle must be locked. Lifting capacities are based on the machine standing on a firm uniform supporting surface. For lifting capacity including bucket and/or quick coupler, the respective weight has to be subtracted from above values. The use of a work tool attachment point to handle/lift objects, could affect the machine lift performance.

Always refer to the appropriate Operation and Maintenance Manual for specific product information.

Lift Capacities

All values are in kg, hydraulic cab riser, work tool: none, with counterweight (4100 kg), heavy lift on.

		Load point height	Load over front	Load over rear	Load over side	Load at maximum reach (sticknose/bucket pin)													
Undercarriage		Boom						Stick											
MH or Standard		6.8 m MH						4.9 m MH											
	Undercarriage configuration	4500 mm			6000 mm			7500 mm			9000 mm			10 500 mm			mm		
12 000 mm	MH – stabilizers up – solid tires															*7800	*7800	5850	
	MH – stabilizers down – solid tires															*7800	*7800	*7800	
	Lower (std UC) – f. stabilizer & r. dozer up															7700	7250	5600	
	Lower (std UC) – f. stabilizer & r. dozer down															*7800	*7800	*7800	
	Lower (std UC) – f. dozer & r. stabilizer up															*7800	7000	5600	
	Lower (std UC) – f. dozer & r. stabilizer down															*7800	*7800	*7800	
	Lower (std UC) – 2 sets stabilizers up															*7800	7200	5650	
	Lower (std UC) – 2 sets stabilizers down															*7800	*7800	*7800	
10 500 mm	MH – stabilizers up – solid tires				6450	6450	4900	4400	4400	3300						4400	4400	3300	
	MH – stabilizers down – solid tires				*9150	*9150	*9150	*6300	*6300	*6300						*6300	*6300	*6300	
	Lower (std UC) – f. stabilizer & r. dozer up				6350	6000	4700	4300	4100	3150						4300	4100	3150	
	Lower (std UC) – f. stabilizer & r. dozer down				*9150	*9150	7050	*6300	*6300	4800						*6300	*6300	4800	
	Lower (std UC) – f. dozer & r. stabilizer up				6550	5800	4700	4450	3950	3150						4450	3950	3150	
	Lower (std UC) – f. dozer & r. stabilizer down				*9150	*9150	7200	*6300	*6300	4900						*6300	*6300	4900	
	Lower (std UC) – 2 sets stabilizers up				6500	6000	4750	4400	4050	3200						4400	4050	3200	
	Lower (std UC) – 2 sets stabilizers down				*9150	*9150	8550	*6300	*6300	5800						*6300	*6300	5800	
9000 mm	MH – stabilizers up – solid tires				6550	6550	5000	4550	4550	3450						3300	3300	2450	
	MH – stabilizers down – solid tires				*9250	*9250	*8250	*8050	*8050	7000						*5700	*5700	5150	
	Lower (std UC) – f. stabilizer & r. dozer up				6450	6100	4800	4450	4250	3300						3200	3050	2350	
	Lower (std UC) – f. stabilizer & r. dozer down				*9250	*9250	7150	*8050	*8050	4950						*5700	*5700	3600	
	Lower (std UC) – f. dozer & r. stabilizer up				6650	5900	4800	4600	4100	3300						3300	2950	2350	
	Lower (std UC) – f. dozer & r. stabilizer down				*9250	*9250	7350	*8050	*7100	5050						*5700	5200	3650	
	Lower (std UC) – 2 sets stabilizers up				6600	6100	4850	4550	4200	3350						3300	3050	2350	
	Lower (std UC) – 2 sets stabilizers down				*9250	*9250	8650	*8050	7300	5950						*5700	5350	4350	
7500 mm	MH – stabilizers up – solid tires				6500	6500	4950	4550	4550	3450	3350	3350	2500			2750	2750	2000	
	MH – stabilizers down – solid tires				*9300	*9300	*9300	*8000	*8000	7000	6350	6350	5150			5300	5300	4300	
	Lower (std UC) – f. stabilizer & r. dozer up				6400	6050	4750	4400	4200	3300	3250	3100	2400			2650	2550	1900	
	Lower (std UC) – f. stabilizer & r. dozer down				*9300	*9300	7100	*8000	*8000	4900	6000	5900	3600			5000	4900	3000	
	Lower (std UC) – f. dozer & r. stabilizer up				6600	5850	4750	4550	4100	3300	3350	3000	2400			2750	2450	1900	
	Lower (std UC) – f. dozer & r. stabilizer down				*9300	*9300	7300	*8000	7100	5050	6700	5200	3700			*5400	4300	3050	
	Lower (std UC) – 2 sets stabilizers up				6550	6050	4800	4550	4200	3350	3350	3100	2400			2750	2500	1950	
	Lower (std UC) – 2 sets stabilizers down				*9300	*9300	8600	*8000	7300	5950	6150	5350	4350			5100	4450	3600	
6000 mm	MH – stabilizers up – solid tires				6300	6300	4800	4450	4450	3350	3300	3300	2450	2500	1850	2400	2400	1750	
	MH – stabilizers down – solid tires				*9700	*9700	*9700	*9200	*8200	6900	6300	6300	5150	4900	4900	3950	4700	4700	3800
	Lower (std UC) – f. stabilizer & r. dozer up				6200	5900	4600	4300	4100	3200	3200	3050	2350	2450	2300	1750	2200	1650	
	Lower (std UC) – f. stabilizer & r. dozer down				*9700	*9700	6900	8100	7950	4800	5950	5850	3600	4600	4550	2750	4400	4350	2650
	Lower (std UC) – f. dozer & r. stabilizer up				6400	5700	4600	4450	4000	3200	3300	2950	2350	2550	2250	1750	2400	2150	1650
	Lower (std UC) – f. dozer & r. stabilizer down				*9700	*9700	7100	*8200	7000	4950	6650	5150	3650	5150	4000	2800	4950	3850	2700
	Lower (std UC) – 2 sets stabilizers up				6350	5850	4650	4450	4100	3250	3300	3050	2350	2500	2300	1750	2400	2200	1700
	Lower (std UC) – 2 sets stabilizers down				*9700	*9700	8400	*8200	7200	5850	6100	5300	4350	4750	4100	3350	4550	3950	3200
4500 mm	MH – stabilizers up – solid tires				9500	9500	7050	6050	6050	4500	4250	3200	2400	2500	1800	2200	2200	1600	
	MH – stabilizers down – solid tires				*13 100	*13 100	*13 100	*10 250	*10 250	9700	8350	8350	6700	6200	6200	5050	4850	4350	3550
	Lower (std UC) – f. stabilizer & r. dozer up				9450	8800	6750	5900	5600	4350	4150	3950	3050	3100	2950	2250	2400	2300	1700
	Lower (std UC) – f. stabilizer & r. dozer down				*13 100	*13 100	10 600	*10 250	*10 250	6600	7900	7750	4650	5850	5750	3500	4550	4500	2700
	Lower (std UC) – f. dozer & r. stabilizer up				9750	8550	6750	6100	5400	4350	4300	3800	3050	3200	2850	2250	2500	2200	1700
	Lower (std UC) – f. dozer & r. stabilizer down				*13 100	*13 100	10 950	*10 250	9850	6800	*8400	6800	4750	6550	5050	3550	5100	3950	2750
	Lower (std UC) – 2 sets stabilizers up				9650	8750	6800	6100	5600	4350	4300	3950	3100	3200	2950	2300	2500	2300	1750
	Lower (std UC) – 2 sets stabilizers down				*13 100	*13 100	*13 100	*10 250	10 150	8100	8100	7000	5650	6000	5200	4250	4700	4100	3300

* Limited by hydraulic rather than tipping load.

(continued on next page)

Lift capacity ratings are based on ISO 10567:2007, they do not exceed 87% of hydraulic lifting capacity or 75% of tipping load. The load point is the center line of the bucket pivot mounting pin on the stick. The oscillating axle must be locked. Lifting capacities are based on the machine standing on a firm uniform supporting surface. For lifting capacity including bucket and/or quick coupler, the respective weight has to be subtracted from above values. The use of a work tool attachment point to handle/lift objects, could affect the machine lift performance.

Always refer to the appropriate Operation and Maintenance Manual for specific product information.

Lift Capacities (continued)

All values are in kg, hydraulic cab riser, work tool: none, with counterweight (4100 kg), heavy lift on.



Undercarriage

Boom
6.8 m MH

Stick
4.9 m MH

MH or Standard

Load point height	Undercarriage configuration	4500 mm			6000 mm			7500 mm			9000 mm			10 500 mm			mm			
		Load over front	Load over rear	Load over side	Load over front	Load over rear	Load over side	Load over front	Load over rear	Load over side	Load over front	Load over rear	Load over side	Load at maximum reach (sticknose/bucket pin)						
3000 mm	MH – stabilizers up – solid tires	8700	8700	6300	5650	5650	4150	4050	4050	3000	3100	3100	2250	2400	2400	1750	2100	2100	1500	11 470
	MH – stabilizers down – solid tires	*14 450	*14 450	*14 450	*10 800	*10 800	9250	8100	8100	6500	6100	6100	4900	4800	4800	3900	4150	4150	3400	
	Lower (std UC) – f. stabilizer & r. dozer up	8600	8000	6000	5550	5250	3950	3950	3750	2850	3000	2850	2150	2350	2250	1650	2000	1950	1400	
	Lower (std UC) – f. stabilizer & r. dozer down	*14 450	*14 450	9750	*10 800	*10 800	6200	7650	7500	4450	5750	5650	3350	4500	4450	2650	3900	3850	2300	
	Lower (std UC) – f. dozer & r. stabilizer up	8900	7750	6000	5700	5050	3950	4100	3600	2850	3100	2750	2150	2450	2150	1650	2100	1850	1400	
	Lower (std UC) – f. dozer & r. stabilizer down	*14 450	*14 450	10 050	*10 800	9400	6400	*8600	6550	4550	6400	4950	3450	5050	3900	2700	4400	3400	2350	
1500 mm	MH – stabilizers up – solid tires	8850	8000	6100	5700	5200	4000	4050	3750	2900	3100	2850	2150	2400	2200	1700	2100	1900	1450	11 520
	MH – stabilizers down – solid tires	*14 450	*14 450	12 350	*10 800	9700	7650	7900	6750	5450	5900	5100	4100	4650	4000	3250	4000	3500	2800	
	Lower (std UC) – f. stabilizer & r. dozer up	7950	7950	5600	5250	5250	3800	3850	3850	2800	2950	2950	2150	2350	2350	1700	2050	2050	1450	
	Lower (std UC) – f. stabilizer & r. dozer down	*14 950	*14 950	14 250	*10 950	*10 950	8800	7850	7850	6250	5950	5950	4800	4700	4700	3800	4100	4100	3300	
	Lower (std UC) – f. dozer & r. stabilizer up	7800	7250	5300	5150	4850	3600	3750	3550	2650	2850	2750	2050	2250	2150	1600	1950	1900	1350	
	Lower (std UC) – f. dozer & r. stabilizer down	*14 950	*14 950	8900	10 750	10 400	5850	7400	7250	4250	5600	5500	3250	4450	4350	2600	3850	3800	2250	
0 mm	MH – stabilizers up – solid tires	8100	7000	5300	5350	4650	3600	3900	3400	2650	3000	2600	2050	2350	2100	1600	2050	1800	1350	11 520
	MH – stabilizers down – solid tires	*14 950	14 700	9250	*10 950	8950	6000	8400	6350	4350	6300	4800	3350	4950	3800	2650	4300	3350	2300	
	Lower (std UC) – f. stabilizer & r. dozer up	8050	7200	5350	5300	4850	3650	3850	3550	2700	2950	2700	2050	2350	2150	1600	2050	1850	1400	
	Lower (std UC) – f. stabilizer & r. dozer down	*14 950	*14 950	11 450	*10 950	9250	7250	7650	6500	5200	5750	4950	4000	4550	3950	3200	3950	3450	2750	
	Lower (std UC) – f. dozer & r. stabilizer up	7450	7450	5150	5000	5000	3550	3700	3700	2650	2850	2850	2050	2300	2300	1650	2050	1850	1350	
	Lower (std UC) – f. dozer & r. stabilizer down	*10 200	*10 200	*10 200	*10 450	*10 450	8450	7650	7650	6050	5850	5850	4650	4650	4650	3750	4100	4100	3300	
-1500 mm	MH – stabilizers up – solid tires	7300	6750	4850	4850	4550	3350	3550	3400	2500	2750	2650	1950	2200	2100	1550	1950	1900	1350	11 520
	MH – stabilizers down – solid tires	*10 200	*10 200	8400	10 350	10 050	5550	7200	7050	4050	5500	5400	3150	4350	4300	2550	3750	3750	2600	
	Lower (std UC) – f. stabilizer & r. dozer up	7600	6500	4850	5050	4400	3350	3700	3250	2500	2900	2500	1950	2300	2050	1550	1950	1900	1350	
	Lower (std UC) – f. stabilizer & r. dozer down	*10 200	*10 200	8700	*10 450	8600	5700	*8150	6150	4150	6150	4700	3250	4900	3750	2600	4300	3350	2300	
	Lower (std UC) – f. dozer & r. stabilizer up	7550	6750	4950	5000	4550	3400	3700	3350	2550	2850	2600	1950	2300	2100	1550	1950	1900	1350	
	Lower (std UC) – f. dozer & r. stabilizer down	*10 200	*10 200	*10 200	*10 450	8900	6950	7400	6350	5050	5650	4850	3900	4500	3900	3100	4100	3500	2800	

*Limited by hydraulic rather than tipping load.

Lift capacity ratings are based on ISO 10567:2007, they do not exceed 87% of hydraulic lifting capacity or 75% of tipping load. The load point is the center line of the bucket pivot mounting pin on the stick. The oscillating axle must be locked. Lifting capacities are based on the machine standing on a firm uniform supporting surface. For lifting capacity including bucket and/or quick coupler, the respective weight has to be subtracted from above values. The use of a work tool attachment point to handle/lift objects, could affect the machine lift performance.

Always refer to the appropriate Operation and Maintenance Manual for specific product information.

Lift Capacities

All values are in lb, hydraulic cab riser, work tool: none, with counterweight (9040 lb), heavy lift on.

		Load point height			Load over front			Load over rear			Load over side			Load at maximum reach (sticknose/bucket pin)			
Undercarriage		Boom									Stick						
MH or Standard		15 ft			20 ft			25 ft			30 ft			35 ft			
	Undercarriage configuration																ft
		40 ft	MH – stabilizers up – solid tires MH – stabilizers down – solid tires Lower (std UC) – f. stabilizer & r. dozer up Lower (std UC) – f. stabilizer & r. dozer down Lower (std UC) – f. dozer & r. stabilizer up Lower (std UC) – f. dozer & r. stabilizer down Lower (std UC) – 2 sets stabilizers up Lower (std UC) – 2 sets stabilizers down	*19,000	*19,000	15,700											
35 ft	MH – stabilizers up – solid tires MH – stabilizers down – solid tires Lower (std UC) – f. stabilizer & r. dozer up Lower (std UC) – f. stabilizer & r. dozer down Lower (std UC) – f. dozer & r. stabilizer up Lower (std UC) – f. dozer & r. stabilizer down Lower (std UC) – 2 sets stabilizers up Lower (std UC) – 2 sets stabilizers down				13,800	13,800	10,500										23.95
30 ft	MH – stabilizers up – solid tires MH – stabilizers down – solid tires Lower (std UC) – f. stabilizer & r. dozer up Lower (std UC) – f. stabilizer & r. dozer down Lower (std UC) – f. dozer & r. stabilizer up Lower (std UC) – f. dozer & r. stabilizer down Lower (std UC) – 2 sets stabilizers up Lower (std UC) – 2 sets stabilizers down				14,000	14,000	10,700	9700	9700	7400							29.07
25 ft	MH – stabilizers up – solid tires MH – stabilizers down – solid tires Lower (std UC) – f. stabilizer & r. dozer up Lower (std UC) – f. stabilizer & r. dozer down Lower (std UC) – f. dozer & r. stabilizer up Lower (std UC) – f. dozer & r. stabilizer down Lower (std UC) – 2 sets stabilizers up Lower (std UC) – 2 sets stabilizers down				*20,300	*20,300	*20,200	*17,600	*17,600	15,000	7100	7100	5300				32.64
20 ft	MH – stabilizers up – solid tires MH – stabilizers down – solid tires Lower (std UC) – f. stabilizer & r. dozer up Lower (std UC) – f. stabilizer & r. dozer down Lower (std UC) – f. dozer & r. stabilizer up Lower (std UC) – f. dozer & r. stabilizer down Lower (std UC) – 2 sets stabilizers up Lower (std UC) – 2 sets stabilizers down				*21,000	*21,000	*21,000	*17,800	*17,800	14,800	13,600	13,600	11,000	5400	5400	3900	35.10
15 ft	MH – stabilizers up – solid tires MH – stabilizers down – solid tires Lower (std UC) – f. stabilizer & r. dozer up Lower (std UC) – f. stabilizer & r. dozer down Lower (std UC) – f. dozer & r. stabilizer up Lower (std UC) – f. dozer & r. stabilizer down Lower (std UC) – 2 sets stabilizers up Lower (std UC) – 2 sets stabilizers down	20,500	20,500	15,200	13,000	13,000	9800	9200	9200	6900	6900	6900	5100	5300	5300	3900	36.75

*Limited by hydraulic rather than tipping load.

(continued on next page)

Lift capacity ratings are based on ISO 10567:2007, they do not exceed 87% of hydraulic lifting capacity or 75% of tipping load. The load point is the center line of the bucket pivot mounting pin on the stick. The oscillating axle must be locked. Lifting capacities are based on the machine standing on a firm uniform supporting surface. For lifting capacity including bucket and/or quick coupler, the respective weight has to be subtracted from above values. The use of a work tool attachment point to handle/lift objects, could affect the machine lift performance.

Always refer to the appropriate Operation and Maintenance Manual for specific product information.

Lift Capacities (continued)

All values are in lb, hydraulic cab riser, work tool: none, with counterweight (9040 lb), heavy lift on.



Undercarriage

Boom
22'4" MH

Stick
16'1" MH

MH or Standard

Load point height	Undercarriage configuration	15 ft			20 ft			25 ft			30 ft			35 ft			ft		
		Load over front	Load over rear	Load over side	Load over front	Load over rear	Load over side	Load over front	Load over rear	Load over side	Load over front	Load over rear	Load over side	Load over front	Load over rear	Load over side			
10 ft	MH – stabilizers up – solid tires	18,800	18,800	13,600	12,200	12,200	9000	8800	8800	6500	6600	6600	4900	5200	5200	3800	4600	4600	3300
	MH – stabilizers down – solid tires	*31,300	*31,300	*31,300	*23,400	*23,400	19,900	17,400	17,400	14,000	13,100	13,100	10,600	10,300	10,300	8300	9200	9200	7500
	Lower (std UC) – f. stabilizer & r. dozer up	18,800	17,300	13,000	11,900	11,300	8600	8500	8100	6100	6400	6100	4600	5000	4800	3600	4400	4300	3100
	Lower (std UC) – f. stabilizer & r. dozer down	*31,300	*31,300	21,000	*23,400	23,300	13,400	16,500	16,100	9600	12,300	12,100	7300	9700	9500	5700	8600	8500	5100
	Lower (std UC) – f. dozer & r. stabilizer up	19,200	16,700	13,000	12,400	10,900	8600	8800	7800	6100	6700	5900	4600	5200	4600	3600	4600	4100	3100
	Lower (std UC) – f. dozer & r. stabilizer down	*31,300	*31,300	21,700	*23,400	20,200	13,800	18,600	14,100	9800	13,800	10,600	7400	10,800	8400	5800	9700	7500	5200
5 ft	Lower (std UC) – 2 sets stabilizers up	19,100	17,200	13,200	12,300	11,200	8700	8800	8100	6200	6600	6100	4700	5200	4800	3600	4600	4200	3200
	Lower (std UC) – 2 sets stabilizers down	*31,300	*31,300	26,500	*23,400	20,800	16,500	16,900	14,500	11,700	12,700	11,000	8900	10,000	8600	7000	8900	7700	6200
	MH – stabilizers up – solid tires	17,100	17,100	12,100	11,400	11,400	8200	8300	8300	6100	6400	6400	4600	5100	5100	3600	4500	4500	3200
	MH – stabilizers down – solid tires	*32,400	*32,400	30,500	*23,800	*23,800	18,900	16,900	16,900	13,500	12,800	12,800	10,300	10,200	10,200	8200	9100	9100	7300
	Lower (std UC) – f. stabilizer & r. dozer up	16,800	15,700	11,500	11,100	10,500	7800	8100	7700	5700	6200	5900	4400	4900	4700	3400	4300	4200	3000
	Lower (std UC) – f. stabilizer & r. dozer down	*32,400	*32,400	19,200	23,000	22,300	12,600	16,000	15,600	9100	12,000	11,800	7000	9500	9400	5600	8500	8400	5000
0 ft	Lower (std UC) – f. dozer & r. stabilizer up	17,500	15,100	11,500	11,500	10,100	7800	8400	7400	5700	6400	5600	4400	5100	4500	3400	4500	4000	3000
	Lower (std UC) – f. dozer & r. stabilizer down	*32,400	31,500	19,900	*23,800	19,300	12,900	18,000	13,600	9400	13,500	10,400	7200	10,700	8200	5700	9500	7300	5100
	Lower (std UC) – 2 sets stabilizers up	17,300	15,600	11,600	11,400	10,400	7900	8300	7600	5800	6400	5900	4400	5100	4600	3500	4500	4100	3100
	Lower (std UC) – 2 sets stabilizers down	*32,400	*32,400	24,600	23,600	19,900	15,600	16,400	14,000	11,200	12,400	10,700	8600	9800	8500	6800	8700	7600	6100
	MH – stabilizers up – solid tires	16,000	16,000	11,100	10,800	10,800	7700	7900	7900	5700	6200	6200	4400	5000	5000	3500			
	MH – stabilizers down – solid tires	*23,900	*23,900	*23,900	*22,700	*22,700	18,200	16,500	16,500	13,100	12,600	12,600	10,100	10,000	10,000	8100			
-5 ft	Lower (std UC) – f. stabilizer & r. dozer up	15,700	14,600	10,500	10,500	9900	7200	7700	5400	6000	5700	4200	4800	4600	3300				
	Lower (std UC) – f. stabilizer & r. dozer down	*23,900	*23,900	18,100	22,200	21,600	11,900	15,500	15,200	8700	11,800	11,600	6800	9400	9300	5500			
	Lower (std UC) – f. dozer & r. stabilizer up	16,400	14,000	10,500	10,900	9500	7200	8000	7000	5400	6200	5400	4200	5000	4400	3300			
	Lower (std UC) – f. dozer & r. stabilizer down	*23,900	*23,900	18,700	*22,700	18,500	12,300	17,600	13,200	9000	13,300	10,100	7000	*10,500	8100	5600			
	Lower (std UC) – 2 sets stabilizers up	16,200	14,500	10,600	10,800	9800	7300	8000	7300	5500	6200	5600	4200	5000	4500	3400			
	Lower (std UC) – 2 sets stabilizers down	*23,900	*23,900	23,300	*22,700	19,100	15,000	16,000	13,600	10,800	12,100	10,500	8400	9700	8400	6700			

*Limited by hydraulic rather than tipping load.

Lift capacity ratings are based on ISO 10567:2007, they do not exceed 87% of hydraulic lifting capacity or 75% of tipping load. The load point is the center line of the bucket pivot mounting pin on the stick. The oscillating axle must be locked. Lifting capacities are based on the machine standing on a firm uniform supporting surface. For lifting capacity including bucket and/or quick coupler, the respective weight has to be subtracted from above values. The use of a work tool attachment point to handle/lift objects, could affect the machine lift performance.

Always refer to the appropriate Operation and Maintenance Manual for specific product information.

Lift Capacities

All values are in kg, hydraulic cab riser, work tool: none, with counterweight (5200 kg), heavy lift on.

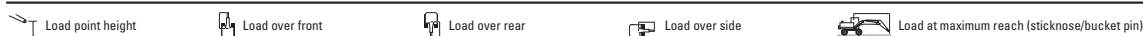

Undercarriage MH or Standard		Boom 6.8 m MH									Stick 4.9 m MH					
		4500 mm			6000 mm			7500 mm			9000 mm			10 500 mm		
Load point height	Undercarriage configuration	Load over front	Load over rear	Load over side	Load over front	Load over rear	Load over side	Load over front	Load over rear	Load over side	Load over front	Load over rear	Load over side	Load at maximum reach (sticknose/bucket pin)	mm	
		12 000 mm	MH – stabilizers up – solid tires													
MH – stabilizers down – solid tires																
Lower (std UC) – f. stabilizer & r. dozer up																
Lower (std UC) – f. stabilizer & r. dozer down																
Lower (std UC) – f. dozer & r. stabilizer up																
Lower (std UC) – f. dozer & r. stabilizer down																
Lower (std UC) – 2 sets stabilizers up																
Lower (std UC) – 2 sets stabilizers down																
10 500 mm	MH – stabilizers up – solid tires				7150	7150	5500	4900	4900	3800						
	MH – stabilizers down – solid tires				*9150	*9150	*9150	*6300	*6300	*6300						
	Lower (std UC) – f. stabilizer & r. dozer up				7050	6650	5300	4850	4600	3600						
	Lower (std UC) – f. stabilizer & r. dozer down				*9150	*9150	7800	*6300	*6300	5350						
	Lower (std UC) – f. dozer & r. stabilizer up				7250	6500	5300	4950	4450	3600						
	Lower (std UC) – f. dozer & r. stabilizer down				*9150	*9150	8000	*6300	*6300	5450						
	Lower (std UC) – 2 sets stabilizers up				7200	6650	5350	4950	4600	3650						
	Lower (std UC) – 2 sets stabilizers down				*9150	*9150	*9150	*6300	*6300	*6300						
9000 mm	MH – stabilizers up – solid tires				7250	7250	5600	5050	5050	3900						
	MH – stabilizers down – solid tires				*9250	*9250	*9250	*8050	*8050	7700						
	Lower (std UC) – f. stabilizer & r. dozer up				7150	6750	5400	4950	4750	3750						
	Lower (std UC) – f. stabilizer & r. dozer down				*9250	*9250	7900	*8050	*8050	5500						
	Lower (std UC) – f. dozer & r. stabilizer up				7350	6600	5400	5100	4600	3750						
	Lower (std UC) – f. dozer & r. stabilizer down				*9250	*9250	8100	*8050	7800	5600						
	Lower (std UC) – 2 sets stabilizers up				7300	6750	5450	5100	4700	3800						
	Lower (std UC) – 2 sets stabilizers down				*9250	*9250	*9250	*8050	8000	6550						
7500 mm	MH – stabilizers up – solid tires				7200	7200	5550	5050	5050	3900	3750	3750	2850			
	MH – stabilizers down – solid tires				*9300	*9300	*9300	*8000	*8000	7700	6950	6950	5700			
	Lower (std UC) – f. stabilizer & r. dozer up				7100	6700	5350	4950	4700	3750	3650	3500	2750			
	Lower (std UC) – f. stabilizer & r. dozer down				*9300	*9300	7850	*8000	*8000	5500	6600	6500	4050			
	Lower (std UC) – f. dozer & r. stabilizer up				7300	6550	5350	5100	4600	3750	3800	3400	2750			
	Lower (std UC) – f. dozer & r. stabilizer down				*9300	*9300	8050	*8000	7800	5600	*7000	5750	4150			
	Lower (std UC) – 2 sets stabilizers up				7250	6700	5400	5100	4700	3800	3750	3500	2750			
	Lower (std UC) – 2 sets stabilizers down				*9300	*9300	*9300	*8000	8000	6550	6900	5900	4650			
6000 mm	MH – stabilizers up – solid tires				7000	7000	5400	4950	4950	3800	3700	3700	2850	2850	2150	
	MH – stabilizers down – solid tires				*9700	*9700	*9700	*8200	*8200	7550	6900	6900	5650	5400	5400	4400
	Lower (std UC) – f. stabilizer & r. dozer up				6950	6550	5200	4850	4650	3650	3600	3450	2700	2800	2650	2050
	Lower (std UC) – f. stabilizer & r. dozer down				*9700	*9700	7650	*8200	*8200	5400	6550	6450	4000	5100	5000	3100
	Lower (std UC) – f. dozer & r. stabilizer up				7100	6350	5200	5000	4500	3650	3750	3350	2700	2900	2550	2050
	Lower (std UC) – f. dozer & r. stabilizer down				*9700	*9700	7850	*8200	7700	5500	*7050	5700	4100	5650	4450	3200
	Lower (std UC) – 2 sets stabilizers up				7100	6550	5250	5000	4600	3700	3700	3450	2750	2850	2650	2050
	Lower (std UC) – 2 sets stabilizers down				*9700	*9700	9250	*8200	7900	6450	6750	5850	4800	5200	4550	3750
4500 mm	MH – stabilizers up – solid tires		10 550	7900	6700	6700	5100	4800	4800	3650	3600	3600	2750	2850	2100	
	MH – stabilizers down – solid tires		*13 100	*13 100	*13 100	*10 250	*10 250	*10 250	*8400	*8400	7400	6800	6800	5550	5350	4350
	Lower (std UC) – f. stabilizer & r. dozer up		10 500	9800	7600	6650	6250	4900	4700	4450	3500	3550	3350	2600	2750	2050
	Lower (std UC) – f. stabilizer & r. dozer down		*13 100	*13 100	11 700	*10 250	*10 250	7350	*8400	*8400	5200	6450	6350	3950	5050	3100
	Lower (std UC) – f. dozer & r. stabilizer up		10 800	9500	7600	6800	6100	4900	4850	4300	3500	3650	3250	2600	2850	2550
	Lower (std UC) – f. dozer & r. stabilizer down		*13 100	*13 100	12 100	*10 250	*10 250	7550	*8400	7500	5350	*7100	5600	4000	5600	4400
	Lower (std UC) – 2 sets stabilizers up		10 750	9750	7650	6800	6250	4950	4800	4450	3550	3650	3350	2650	2850	2600
	Lower (std UC) – 2 sets stabilizers down		*13 100	*13 100	*13 100	*10 250	*10 250	8950	*8400	7700	6250	6650	5750	4750	5200	4550

* Limited by hydraulic rather than tipping load.

(continued on next page)

Lift capacity ratings are based on ISO 10567:2007, they do not exceed 87% of hydraulic lifting capacity or 75% of tipping load. The load point is the center line of the bucket pivot mounting pin on the stick. The oscillating axle must be locked. Lifting capacities are based on the machine standing on a firm uniform supporting surface. For lifting capacity including bucket and/or quick coupler, the respective weight has to be subtracted from above values. The use of a work tool attachment point to handle/lift objects, could affect the machine lift performance.

Always refer to the appropriate Operation and Maintenance Manual for specific product information.

Lift Capacities (continued)

All values are in kg, hydraulic cab riser, work tool: none, with counterweight (5200 kg), heavy lift on.



Undercarriage

Boom
6.8 m MH

Stick
4.9 m MH

MH or Standard

Load point height	Undercarriage configuration	4500 mm			6000 mm			7500 mm			9000 mm			10 500 mm			mm		
		Load over front	Load over rear	Load over side	Load over front	Load over rear	Load over side	Load over front	Load over rear	Load over side	Load over front	Load over rear	Load over side	Load at maximum reach (sticknose/bucket pin)					
3000 mm	MH – stabilizers up – solid tires	9750	9750	7150	6350	6350	4750	4600	4600	3450	3500	3500	2650	2750	2050	2400	2400	1800	
	MH – stabilizers down – solid tires	*14 450	*14 450	*14 450	*10 800	*10 800	10 150	*8600	*8600	7150	6700	6700	5450	5300	5300	4300	4600	3750	
	Lower (std UC) – f. stabilizer & r. dozer up	9650	9000	6850	6250	5900	4550	4500	4250	3300	3400	3250	2500	2700	2550	1950	2350	2250	1700
	Lower (std UC) – f. stabilizer & r. dozer down	*14 450	*14 450	10 850	*10 800	*10 800	6950	8450	8250	5000	6350	6200	3800	5000	4900	3000	4350	4300	2650
	Lower (std UC) – f. dozer & r. stabilizer up	9950	8700	6850	6450	5700	4550	4650	4100	3300	3550	3150	2500	2800	2500	1950	2450	2150	1700
	Lower (std UC) – f. dozer & r. stabilizer down	*14 450	*14 450	11 200	*10 800	10 400	7150	*8600	7250	5100	7050	5500	3900	5550	4350	3100	4850	3800	2700
1500 mm	Lower (std UC) – 2 sets stabilizers up	9900	8950	6950	6400	5850	4600	4600	3350	3500	3250	2550	2800	2550	2000	2400	2200	1700	
	Lower (std UC) – 2 sets stabilizers down	*14 450	*14 450	13 650	*10 800	10 650	8500	*8600	7450	6050	6500	5650	4600	5100	4450	3650	4450	3900	3200
	MH – stabilizers up – solid tires	8950	8950	6450	5950	5950	4400	4350	3250	3400	3400	2500	2700	2700	2000	2350	2350	1750	
	MH – stabilizers down – solid tires	*14 950	*14 950	*14 950	*10 950	*10 950	9750	*8600	*8600	6950	6550	6550	5300	5200	5200	4250	*4400	*4400	3700
	Lower (std UC) – f. stabilizer & r. dozer up	8850	8250	6150	5850	5500	4200	4300	4050	3100	3300	3150	2400	2650	2500	1900	2300	2200	1650
	Lower (std UC) – f. stabilizer & r. dozer down	*14 950	*14 950	10 000	*10 950	*10 950	6550	8200	8000	4800	6200	6100	3700	4900	4850	2950	4300	4250	2650
0 mm	Lower (std UC) – f. dozer & r. stabilizer up	9150	7950	6150	6050	5350	4200	4400	3900	3100	3400	3050	2400	2750	2400	1900	2400	2100	1650
	Lower (std UC) – f. dozer & r. stabilizer down	*14 950	*14 950	10 350	*10 950	9950	6750	*8600	7050	4900	6900	5350	3800	5500	4250	3050	*4400	3750	2650
	Lower (std UC) – 2 sets stabilizers up	9100	8200	6200	6000	5500	4250	4400	4050	3150	3400	3100	2450	2700	2500	1950	2350	2200	1650
	Lower (std UC) – 2 sets stabilizers down	*14 950	*14 950	12 750	*10 950	10 200	8100	8400	7200	5850	6350	5500	4500	5050	4400	3600	*4400	3850	3150
	MH – stabilizers up – solid tires	8450	8450	6000	5650	5650	4150	4200	4200	3100	3300	3300	2400	2650	2650	1950			
	MH – stabilizers down – solid tires	*10 200	*10 200	*10 200	*10 450	*10 450	9400	*8150	*8150	6750	6450	6450	5200	*4950	*4950	4200			
-1500 mm	Lower (std UC) – f. stabilizer & r. dozer up	8350	7750	5700	5550	5250	3950	4100	3900	2950	3200	3050	2300	2600	2450	1850			
	Lower (std UC) – f. stabilizer & r. dozer down	*10 200	*10 200	9500	*10 450	*10 450	6250	8000	7800	4600	6100	5950	3600	4850	4800	2900			
	Lower (std UC) – f. dozer & r. stabilizer up	8650	7450	5700	5750	5050	3950	4250	3750	2950	3300	2950	2300	2700	2350	1850			
	Lower (std UC) – f. dozer & r. stabilizer down	*10 200	*10 200	9850	*10 450	9600	6450	*8150	6850	4750	*6450	5250	3700	*4950	4200	2950			
	Lower (std UC) – 2 sets stabilizers up	8600	7700	5750	5750	5200	4000	4200	3850	3000	3300	3000	2350	2650	2450	1900			
	Lower (std UC) – 2 sets stabilizers down	*10 200	*10 200	*10 200	*10 450	9850	7800	*8150	7050	5850	6250	5400	4350	*4950	4350	3550			
-1500 mm	Lower (std UC) – 2 sets stabilizers up				5500	5500	4000	4100	4100	3000									
	Lower (std UC) – 2 sets stabilizers down				*9050	*9050	*9050	*7150	*7150	6600									
	Lower (std UC) – f. stabilizer & r. dozer up				5400	5100	3800	4000	3800	2850									
	Lower (std UC) – f. stabilizer & r. dozer down				*9050	*9050	6100	*7150	*7150	4500									
	Lower (std UC) – f. dozer & r. stabilizer up				5600	4900	3800	4150	3650	2850									
	Lower (std UC) – f. dozer & r. stabilizer down				*9050	*9050	6300	*7150	6700	4600									

*Limited by hydraulic rather than tipping load.

Lift capacity ratings are based on ISO 10567:2007, they do not exceed 87% of hydraulic lifting capacity or 75% of tipping load. The load point is the center line of the bucket pivot mounting pin on the stick. The oscillating axle must be locked. Lifting capacities are based on the machine standing on a firm uniform supporting surface. For lifting capacity including bucket and/or quick coupler, the respective weight has to be subtracted from above values. The use of a work tool attachment point to handle/lift objects, could affect the machine lift performance.

Always refer to the appropriate Operation and Maintenance Manual for specific product information.

Material Handlers

Lifting Capacities

- MH3024
- (Grenoble Sourced)

Lift Capacities

All values are in lb, hydraulic cab riser, work tool: none, with counterweight (11,470 lb), heavy lift on.

		Load point height	Load over front	Load over rear	Load over side	Load at maximum reach (sticknose/bucket pin)							
		Boom				Stick							
		22'4" MH				16'1" MH							
		15 ft		20 ft		25 ft		30 ft		35 ft			
	Undercarriage configuration											ft	
40 ft	MH – stabilizers up – solid tires	*19,000	*19,000	17,500								15.65	
	MH – stabilizers down – solid tires	*19,000	*19,000	*19,000									
	Lower (std UC) – f. stabilizer & r. dozer up	*19,000	*19,000	16,900									
	Lower (std UC) – f. stabilizer & r. dozer down	*19,000	*19,000	*19,000									
	Lower (std UC) – f. dozer & r. stabilizer up	*19,000	*19,000	16,900									
	Lower (std UC) – f. dozer & r. stabilizer down	*19,000	*19,000	*19,000									
	Lower (std UC) – 2 sets stabilizers up	*19,000	*19,000	17,100									
Lower (std UC) – 2 sets stabilizers down	*19,000	*19,000	*19,000										
35 ft	MH – stabilizers up – solid tires				15,300	15,300	11,800					23.95	
	MH – stabilizers down – solid tires				*19,500	*19,500	*19,500						
	Lower (std UC) – f. stabilizer & r. dozer up				15,100	14,300	11,300						
	Lower (std UC) – f. stabilizer & r. dozer down				*19,500	*19,500	16,700						
	Lower (std UC) – f. dozer & r. stabilizer up				15,500	13,900	11,300						
	Lower (std UC) – f. dozer & r. stabilizer down				*19,500	*19,500	17,100						
	Lower (std UC) – 2 sets stabilizers up				15,400	14,200	11,400						
Lower (std UC) – 2 sets stabilizers down				*19,500	*19,500	*19,500							
30 ft	MH – stabilizers up – solid tires				15,500	15,500	12,000	10,800	10,800	8400		29.07	
	MH – stabilizers down – solid tires				*20,200	*20,200	*20,200	*17,600	*17,600	16,500			
	Lower (std UC) – f. stabilizer & r. dozer up				15,300	14,500	11,600	10,600	10,100	8000			
	Lower (std UC) – f. stabilizer & r. dozer down				*20,200	*20,200	16,900	*17,600	*17,600	11,800			
	Lower (std UC) – f. dozer & r. stabilizer up				15,800	14,100	11,600	11,000	9800	8000			
	Lower (std UC) – f. dozer & r. stabilizer down				*20,200	*20,200	17,400	*17,600	16,700	12,000			
	Lower (std UC) – 2 sets stabilizers up				15,700	14,500	11,700	10,900	10,100	8100			
Lower (std UC) – 2 sets stabilizers down				*20,200	*20,200	*20,200	*17,600	17,100	14,100				
25 ft	MH – stabilizers up – solid tires				15,500	15,500	11,900	10,900	10,900	8400	8000	8000	6100
	MH – stabilizers down – solid tires				*20,300	*20,300	*20,300	*17,500	*17,500	16,500	14,900	14,900	12,200
	Lower (std UC) – f. stabilizer & r. dozer up				15,300	14,500	11,500	10,700	10,200	8100	7900	7500	5900
	Lower (std UC) – f. stabilizer & r. dozer down				*20,300	*20,300	16,900	*17,500	*17,500	11,800	14,200	13,900	8700
	Lower (std UC) – f. dozer & r. stabilizer up				15,700	14,100	11,500	11,000	9800	8100	8100	7300	5900
	Lower (std UC) – f. dozer & r. stabilizer down				*20,300	*20,300	17,300	*17,500	16,700	12,100	*15,300	12,400	8900
	Lower (std UC) – 2 sets stabilizers up				15,600	14,400	11,600	10,800	10,100	8100	8100	7500	5900
Lower (std UC) – 2 sets stabilizers down				*20,300	*20,300	20,300	*17,500	17,200	14,100	14,500	12,700	10,400	
20 ft	MH – stabilizers up – solid tires				15,100	15,100	11,600	10,700	10,700	8200	8000	8000	6100
	MH – stabilizers down – solid tires				*21,000	*21,000	*21,000	*17,800	*17,800	16,300	14,900	14,900	12,200
	Lower (std UC) – f. stabilizer & r. dozer up				14,900	14,100	11,200	10,500	10,000	7900	7800	7400	5800
	Lower (std UC) – f. stabilizer & r. dozer down				*21,000	*21,000	16,500	*17,800	*17,800	11,600	14,100	13,900	8700
	Lower (std UC) – f. dozer & r. stabilizer up				15,300	13,700	11,200	10,800	9700	7900	8000	7200	5800
	Lower (std UC) – f. dozer & r. stabilizer down				*21,000	*21,000	16,900	*17,800	16,500	11,900	*15,300	12,300	8900
	Lower (std UC) – 2 sets stabilizers up				15,300	14,100	11,300	10,700	9900	7900	8000	7400	5900
Lower (std UC) – 2 sets stabilizers down				*21,000	*21,000	19,900	*17,800	16,900	13,900	14,500	12,600	10,400	
15 ft	MH – stabilizers up – solid tires	22,700	22,700	17,000	14,500	14,500	11,000	10,300	10,300	7900	7800	7800	5900
	MH – stabilizers down – solid tires	*28,400	*28,400	*28,400	*22,200	*22,200	*22,200	*18,300	*18,300	15,900	14,700	14,700	12,000
	Lower (std UC) – f. stabilizer & r. dozer up	22,600	21,100	16,400	14,300	13,500	10,600	10,100	9600	7500	7600	7300	5600
	Lower (std UC) – f. stabilizer & r. dozer down	*28,400	*28,400	25,200	*22,200	*22,200	15,900	*18,300	*18,300	11,200	13,900	13,700	8500
	Lower (std UC) – f. dozer & r. stabilizer up	23,200	20,500	16,400	14,700	13,100	10,600	10,400	9300	7500	7900	7000	5600
	Lower (std UC) – f. dozer & r. stabilizer down	*28,400	*28,400	26,000	*22,200	*22,200	16,300	*18,300	16,100	11,500	*15,400	12,100	8700
	Lower (std UC) – 2 sets stabilizers up	23,100	21,000	16,600	14,600	13,500	10,700	10,400	9600	7600	7800	7200	5700
Lower (std UC) – 2 sets stabilizers down	*28,400	*28,400	*28,400	*22,200	*22,200	19,200	*18,300	16,600	13,500	14,300	12,400	10,200	

*Limited by hydraulic rather than tipping load.

(continued on next page)

Lift capacity ratings are based on ISO 10567:2007, they do not exceed 87% of hydraulic lifting capacity or 75% of tipping load. The load point is the center line of the bucket pivot mounting pin on the stick. The oscillating axle must be locked. Lifting capacities are based on the machine standing on a firm uniform supporting surface. For lifting capacity including bucket and/or quick coupler, the respective weight has to be subtracted from above values. The use of a work tool attachment point to handle/lift objects, could affect the machine lift performance.

Always refer to the appropriate Operation and Maintenance Manual for specific product information.

Lift Capacities (continued)

All values are in lb, hydraulic cab riser, work tool: none, with counterweight (11,470 lb), heavy lift on.



Undercarriage

Boom
22"4" MH

Stick
16'1" MH

MH or Standard

Load point height	Undercarriage configuration	15 ft			20 ft			25 ft			30 ft			35 ft			Load at maximum reach (sticknose/bucket pin)			ft
		Load over front	Load over rear	Load over side	Load over front	Load over rear	Load over side	Load over front	Load over rear	Load over side	Load over front	Load over rear	Load over side	Load over front	Load over rear	Load over side	Load over front	Load over rear	Load over side	
10 ft	MH – stabilizers up – solid tires	21,000	21,000	15,500	13,700	13,700	10,300	9,900	9,900	7,500	7,500	7,500	5,700	6,000	6,000	4,400	5,300	5,300	3,900	37.63
	MH – stabilizers down – solid tires	*31,300	*31,300	*31,300	*23,400	*23,400	21,900	*18,700	*18,700	15,400	14,400	14,400	11,700	11,400	11,400	9,300	10,200	10,200	8,300	
	Lower (std UC) – f. stabilizer & r. dozer up	20,900	19,400	14,800	13,500	12,700	9,900	9,700	9,200	7,100	7,400	7,000	5,400	5,800	5,500	4,200	5,200	4,900	3,700	
	Lower (std UC) – f. stabilizer & r. dozer down	*31,300	*31,300	23,400	*23,400	*23,400	15,000	18,200	17,800	10,800	13,600	13,400	8,200	10,700	10,600	6,500	9,600	9,500	5,800	
	Lower (std UC) – f. dozer & r. stabilizer up	21,500	18,800	14,800	13,900	12,300	9,900	10,000	8,900	7,100	7,600	6,800	5,400	6,000	5,300	4,200	5,400	4,700	3,700	
	Lower (std UC) – f. dozer & r. stabilizer down	*31,300	*31,300	24,200	*23,400	22,300	15,400	*18,700	15,600	11,000	15,200	11,800	8,400	12,000	9,300	6,700	10,700	8,400	5,900	
5 ft	Lower (std UC) – 2 sets stabilizers up	21,400	19,300	15,000	13,800	12,700	10,000	9,900	9,200	7,200	7,600	7,000	5,500	6,000	5,500	4,300	5,300	4,900	3,800	37.63
	Lower (std UC) – 2 sets stabilizers down	*31,300	*31,300	29,300	*23,400	22,900	18,300	18,600	16,100	13,000	14,000	12,100	9,900	11,000	9,600	7,900	9,900	8,600	7,000	
	MH – stabilizers up – solid tires	19,300	19,300	13,900	12,900	12,900	9,500	9,400	9,400	7,000	7,300	7,300	5,400	5,800	5,800	4,300	5,200	5,200	3,800	
	MH – stabilizers down – solid tires	*32,400	*32,400	*32,400	*23,800	*23,800	20,900	18,600	18,600	14,900	14,100	14,100	11,400	11,200	11,200	9,100	*9,700	*9,700	8,200	
	Lower (std UC) – f. stabilizer & r. dozer up	19,100	17,800	13,300	12,600	11,900	9,100	9,200	8,800	6,700	7,100	6,800	5,200	5,700	5,400	4,100	5,100	4,800	3,600	
	Lower (std UC) – f. stabilizer & r. dozer down	*32,400	*32,400	21,600	*23,800	*23,800	14,200	17,700	17,200	10,300	13,300	13,100	8,000	10,600	10,400	6,400	9,500	9,300	5,700	
0 ft	Lower (std UC) – f. dozer & r. stabilizer up	19,700	17,200	13,300	13,100	11,500	9,100	9,500	8,400	6,700	7,400	6,500	5,200	5,900	5,200	4,100	5,200	4,600	3,600	37.63
	Lower (std UC) – f. dozer & r. stabilizer down	*32,400	*32,400	22,300	*23,800	21,400	14,600	*18,600	15,100	10,600	14,900	11,500	8,200	11,800	9,200	6,500	*9,700	8,200	5,800	
	Lower (std UC) – 2 sets stabilizers up	19,600	17,700	13,400	13,000	11,900	9,200	9,500	8,700	6,800	7,300	6,700	5,200	5,800	5,400	4,100	5,200	4,800	3,700	
	Lower (std UC) – 2 sets stabilizers down	*32,400	*32,400	27,400	*23,800	21,900	17,400	18,100	15,600	12,600	13,700	11,900	9,700	10,900	9,500	7,700	*9,700	8,500	6,900	
	MH – stabilizers up – solid tires	18,200	18,200	12,900	12,200	12,200	8,900	9,100	9,100	6,700	7,100	7,100	5,200	5,700	5,700	4,200				
	MH – stabilizers down – solid tires	*23,900	*23,900	*23,900	*22,700	*22,700	20,200	*17,700	*17,700	14,500	13,800	13,800	11,200	*10,500	*10,500	9,000				
-5 ft	Lower (std UC) – f. stabilizer & r. dozer up	18,000	16,700	12,300	12,000	11,300	8,500	8,900	8,400	6,400	6,900	6,600	5,000	5,600	5,300	4,000				37.63
	Lower (std UC) – f. stabilizer & r. dozer down	*23,900	*23,900	20,500	*22,700	*22,700	13,500	17,200	16,800	10,000	13,100	12,900	7,800	10,500	10,300	6,300				
	Lower (std UC) – f. dozer & r. stabilizer up	18,600	16,100	12,300	12,400	10,900	8,500	9,200	8,100	6,400	7,100	6,300	5,000	5,800	5,100	4,000				
	Lower (std UC) – f. dozer & r. stabilizer down	*23,900	*23,900	21,200	*22,700	20,600	13,900	*17,700	14,700	10,200	*13,900	11,300	7,900	*10,500	9,100	6,400				
	Lower (std UC) – 2 sets stabilizers up	18,500	16,600	12,500	12,300	11,200	8,600	9,100	8,300	6,400	7,100	6,500	5,000	5,700	5,300	4,000				
	Lower (std UC) – 2 sets stabilizers down	*23,900	*23,900	*23,900	*22,700	21,200	16,800	17,700	15,100	12,200	13,400	11,600	9,400	*10,500	9,400	7,600				

*Limited by hydraulic rather than tipping load.

Lift capacity ratings are based on ISO 10567:2007, they do not exceed 87% of hydraulic lifting capacity or 75% of tipping load. The load point is the center line of the bucket pivot mounting pin on the stick. The oscillating axle must be locked. Lifting capacities are based on the machine standing on a firm uniform supporting surface. For lifting capacity including bucket and/or quick coupler, the respective weight has to be subtracted from above values. The use of a work tool attachment point to handle/lift objects, could affect the machine lift performance.

Always refer to the appropriate Operation and Maintenance Manual for specific product information.

Lift Capacities

All values are in kg, hydraulic cab riser, work tool: none, with counterweight (4100 kg), heavy lift on.



Undercarriage

Boom
6.8 m MH

Stick
5.9 m MH

MH or Standard

Stick height	Undercarriage configuration	3000 mm			4500 mm			6000 mm			7500 mm			9000 mm			10 500 mm			12 000 mm			mm						
		Icon 1	Icon 2	Icon 3	Icon 1	Icon 2	Icon 3	Icon 1	Icon 2	Icon 3	Icon 1	Icon 2	Icon 3	Icon 1	Icon 2	Icon 3	Icon 1	Icon 2	Icon 3	Icon 1	Icon 2	Icon 3							
12 000 mm	MH – stabilizers up – solid tires							6500	6500	4950													4850	4850	3700				
	MH – stabilizers down – solid tires							*7450	*7450	*7450													*5700	*5700	*5700				
	Lower (std UC) – f. stabilizer & r. dozer up							6400	6050	4750													4750	4550	3550				
	Lower (std UC) – f. stabilizer & r. dozer down							*7450	*7450	7100													*5700	*5700	5300				
	Lower (std UC) – f. dozer & r. stabilizer up							6600	5850	4750													4900	4400	3550				
	Lower (std UC) – f. dozer & r. stabilizer down							*7450	*7450	7300													*5700	*5700	5450				
	Lower (std UC) – 2 sets stabilizers up							6550	6050	4800													4900	4500	3550				
	Lower (std UC) – 2 sets stabilizers down							*7450	*7450	*7450													*5700	*5700	*5700				
10 500 mm	MH – stabilizers up – solid tires										4650	4650	3550												3400	3400	2550		
	MH – stabilizers down – solid tires										*7250	*7250	7150												*4950	*4950	*4950		
	Lower (std UC) – f. stabilizer & r. dozer up										4550	4350	3400												4750	4550	2400		
	Lower (std UC) – f. stabilizer & r. dozer down										*7250	*7250	5050												*4950	*4950	3700		
	Lower (std UC) – f. dozer & r. stabilizer up										4700	4200	3400												3400	3050	2400		
	Lower (std UC) – f. dozer & r. stabilizer down										*7250	7250	5150												*4950	*4950	3750		
	Lower (std UC) – 2 sets stabilizers up										4650	4300	3450												3400	3150	2450		
	Lower (std UC) – 2 sets stabilizers down										*7250	*7250	6050												*4950	*4950	4000		
9000 mm	MH – stabilizers up – solid tires										4700	4700	3600	3450	3450	2600										2700	2700	2000	
	MH – stabilizers down – solid tires										*7450	*7450	7200	6500	6500	5300										*4550	*4550	4250	
	Lower (std UC) – f. stabilizer & r. dozer up										4600	4400	3450	3350	3200	2450										2650	2500	1900	
	Lower (std UC) – f. stabilizer & r. dozer down										*7450	*7450	5100	6150	6050	3700										*4550	*4550	2950	
	Lower (std UC) – f. dozer & r. stabilizer up										4750	4250	3450	3450	3050	2450										2700	2400	1900	
	Lower (std UC) – f. dozer & r. stabilizer down										*7450	7300	5250	*6700	5350	3800										*4550	4250	3000	
	Lower (std UC) – 2 sets stabilizers up										4700	4350	3500	3450	3150	2500										2700	2500	1900	
	Lower (std UC) – 2 sets stabilizers down										*7450	*7450	6150	6300	5500	4500										*4550	4400	3550	
7500 mm	MH – stabilizers up – solid tires										4700	4700	3600	3450	3450	2600	2600	2600	1900							2300	2300	1700	
	MH – stabilizers down – solid tires										*7500	*7500	7200	6500	6500	5300	5000	5000	4050							*4350	*4350	3650	
	Lower (std UC) – f. stabilizer & r. dozer up										4600	4350	3450	3350	3200	2450	2500	2400	1800							2200	2150	1600	
	Lower (std UC) – f. stabilizer & r. dozer down										*7500	*7500	5100	6150	6050	3750	4700	4650	2800							4250	4200	2500	
	Lower (std UC) – f. dozer & r. stabilizer up										4700	4250	3450	3450	3100	2450	2600	2300	1800							2300	2050	1600	
	Lower (std UC) – f. dozer & r. stabilizer down										*7500	7300	5200	*6650	5350	3800	5250	4100	2800							*4350	3650	2600	
	Lower (std UC) – 2 sets stabilizers up										4700	4350	3450	3450	3200	2500	2600	2400	1800							2300	2100	1600	
	Lower (std UC) – 2 sets stabilizers down										*7500	7500	6100	6300	5500	4500	4800	4200	3400							4350	3800	3050	
6000 mm	MH – stabilizers up – solid tires										4550	4550	3500	3350	3350	2550	2550	2550	1900							2050	2050	1500	
	MH – stabilizers down – solid tires										*7700	*7700	7100	6400	6400	5250	4950	4950	4050								4100	4100	3200
	Lower (std UC) – f. stabilizer & r. dozer up										4450	4250	3350	3200	3150	2400	2500	2400	1800							2000	1900	1400	
	Lower (std UC) – f. stabilizer & r. dozer down										*7700	*7700	4950	6100	5950	3650	4650	4600	2800							3800	3800	2250	
	Lower (std UC) – f. dozer & r. stabilizer up										4600	4100	3350	3400	3000	2400	2600	2300	1800							2050	1800	1400	
	Lower (std UC) – f. dozer & r. stabilizer down										*7700	7150	5100	*6750	5250	3750	5200	4050	2850							4300	3200	2300	
	Lower (std UC) – 2 sets stabilizers up										4600	4250	3350	3350	3100	2450	2550	2350	1800							2050	1900	1400	
	Lower (std UC) – 2 sets stabilizers down										*7700	7350	6000	6250	5400	4400	4800	4200	3400							3950	3400	2750	
4500 mm	MH – stabilizers up – solid tires							6300	6300	4750	4400	4400	3300	3250	3250	2450	2500	2500	1850	1950						1900	1900	1350	
	MH – stabilizers down – solid tires							*9500	*9500	*9500	*8000	*8000	6950	6300	6300	5100	4900	4900	4000	3950	3950	3200	3800	3800	3100			3100	
	Lower (std UC) – f. stabilizer & r. dozer up							6200	5850	4550	4300	4100	3150	3150	3050	2300	2400	2300	1750	1900	1800	1300	1850	1750	1250			1250	
	Lower (std UC) – f. stabilizer & r. dozer down							*9500	*9500	6900	*8000	7900	4800	5950	5850	3550	4600	4550	2750	3700	3650	2150	3550	3550	2100			2100	
	Lower (std UC) – f. dozer & r. stabilizer up							6350	5650	4550	4450	3950	3150	3300	2900	2300	2500	2200	1750	1950	1700	1300	1900	1900	1650	1250			1250
	Lower (std UC) – f. dozer & r. stabilizer down							*9500	*9500	7050	*8000	6950	4900	6650	5150	3950	5150	4000	2800	4100	3200	2200	4000	3100	2150			2150	
	Lower (std UC) – 2 sets stabilizers up							6350	5800	4600	4400	4050	3200	3250	3000	2350	2500	2300	1750	1950	1800	1350	1900	1900	1700			1700	
	Lower (std UC) – 2 sets stabilizers down							*9500	*9500	8400	*8000	7150	5800	6100	5300	4300	4750	4100	3350	3800	3300	2650	3700	3200	2500			2500	

* Limited by hydraulic rather than tipping load.

(continued on next page)

Lift capacity ratings are based on ISO 10567:2007, they do not exceed 87% of hydraulic lifting capacity or 75% of tipping load. The load point is the center line of the bucket pivot mounting pin on the stick. The oscillating axle must be locked. Lifting capacities are based on the machine standing on a firm uniform supporting surface. For lifting capacity including bucket and/or quick coupler, the respective weight has to be subtracted from above values. The use of a work tool attachment point to handle/lift objects, could affect the machine lift performance.

Always refer to the appropriate Operation and Maintenance Manual for specific product information.

Lift Capacities (continued)

All values are in kg, hydraulic cab riser, work tool: none, with counterweight (4100 kg), heavy lift on.



Undercarriage

Boom

Stick

MH or Standard

6.8 m MH

5.9 m MH

Stick height	Undercarriage configuration	3000 mm		4500 mm		6000 mm		7500 mm		9000 mm		10 500 mm		12 000 mm		mm									
		Load over front	Load over rear	Load over front	Load over rear	Load over front	Load over rear	Load over front	Load over rear	Load over front	Load over rear	Load over front	Load over rear	Load over front	Load over rear										
3000 mm	MH – stabilizers up – solid tires			9250	9250	6750	5850	5850	4350	4150	4150	3100	3100	2300	2450	1750	1950	1950	1350	1800	1800	1250			
	MH – stabilizers down – solid tires			*13 350	*13 350	*13 350	*10 250	*10 250	9500	8250	8250	6600	6150	6150	4950	4800	4800	3900	3900	3900	3150	3650	2950		
	Lower (std UC) – f. stabilizer & r. dozer up			9150	8550	6500	5750	5450	4150	4050	3850	2950	3050	2900	2150	2350	2250	1650	1850	1750	1250	1750	1650	1200	
	Lower (std UC) – f. stabilizer & r. dozer down			*13 350	*13 350	10 300	*10 250	*10 250	6450	7800	7650	4550	5800	5700	3400	4500	4450	2650	3650	3600	2100	3450	3400	2000	
	Lower (std UC) – f. dozer & r. stabilizer up			9450	8250	6500	5950	5250	4150	4200	3700	2950	3150	2750	2150	2450	2150	1650	1950	1700	1250	1800	1600	1200	
	Lower (std UC) – f. dozer & r. stabilizer down			*13 350	*13 350	10 650	*10 250	9700	6650	*8350	6700	4650	6500	5000	3500	5050	3900	2700	4100	3150	2150	3850	2950	2050	
1500 mm	MH – stabilizers up – solid tires			8300	8300	5900	5400	5400	3950	3900	2850	2950	2950	2150	2350	2350	1650	1900	1900	1300	1750	1750	1250		
	MH – stabilizers down – solid tires			*14 600	*14 600	*14 600	*10 750	*10 750	9000	7950	7950	6350	5950	5950	4800	4700	4700	3800	3850	3850	3100	3600	3600	2900	
	Lower (std UC) – f. stabilizer & r. dozer up			8200	7600	5650	5300	5000	3750	3800	3600	2700	2900	2750	2050	2250	2150	1550	1800	1750	1250	1700	1600	1150	
	Lower (std UC) – f. stabilizer & r. dozer down			*14 600	*14 600	9300	*10 750	10 600	6000	7500	7350	4300	5600	5500	3250	4400	4350	2550	3600	3550	2050	3400	3350	1950	
	Lower (std UC) – f. dozer & r. stabilizer up			8500	7350	5650	5500	4800	3750	3950	3450	2700	3000	2650	2050	2350	2050	1550	1900	1650	1250	1750	1550	1150	
	Lower (std UC) – f. dozer & r. stabilizer down			*14 600	*14 600	9650	*10 750	9150	6150	8500	6400	4400	6300	4850	3350	4950	3800	2650	4050	3100	2100	3800	2900	2000	
0 mm	MH – stabilizers up – solid tires	*4050	*4050	*4050	7550	7550	5050	5050	3600	3700	3700	2650	2850	2850	2000	2250	2250	1600	1850	1850	1300				
	MH – stabilizers down – solid tires	*4050	*4050	*4050	*14 600	*14 600	13 800	*10 750	*10 750	8550	7700	7700	6100	5800	5800	4650	4600	4600	3700	3800	3800	3050			
	Lower (std UC) – f. stabilizer & r. dozer up	*4050	*4050	*4050	7450	6900	4950	4900	4600	3400	3550	3400	2500	2750	2600	1900	2150	2050	1500	1750	1700	1200			
	Lower (std UC) – f. stabilizer & r. dozer down	*4050	*4050	*4050	*14 600	*14 600	8550	10 450	10 100	5600	7250	7100	4050	5450	5350	3100	4350	4250	2500	3550	3500	2050			
	Lower (std UC) – f. dozer & r. stabilizer up	*4050	*4050	*4050	7750	6600	4950	5100	4450	3400	3700	3250	2500	2850	2500	1900	2250	2000	1500	1850	1600	1200			
	Lower (std UC) – f. dozer & r. stabilizer down	*4050	*4050	*4050	*14 600	14 300	8850	*10 750	8700	5750	8200	6150	4150	6150	4700	3200	4850	3750	2550	4000	3050	2100			
~1500 mm	MH – stabilizers up – solid tires			7150	7150	4900	4750	4750	3350	3500	3500	2500	2750	2750	1950	2200	2200	1550							
	MH – stabilizers down – solid tires			*10 400	*10 400	*10 400	*9950	*9950	8250	7500	7500	5900	5700	5700	4550	4550	4550	3650							
	Lower (std UC) – f. stabilizer & r. dozer up			7050	6500	4600	4650	4350	3150	3400	3200	2350	2650	2500	1800	2100	2000	1450							
	Lower (std UC) – f. stabilizer & r. dozer down			*10 400	*10 400	8100	*9950	9800	5300	7050	6900	3900	5350	5250	3000	4250	4200	2450							
	Lower (std UC) – f. dozer & r. stabilizer up			7300	6250	4600	4850	4200	3150	3550	3100	2350	2750	2400	1800	2200	1900	1450							
	Lower (std UC) – f. dozer & r. stabilizer down			*10 400	*10 400	8400	*9950	8400	5500	*7750	5950	4000	6050	4550	3100	*4750	3650	2500							
Lower (std UC) – 2 sets stabilizers up			7250	6450	4650	4800	4350	3200	3500	3200	2350	2750	2500	1850	2200	2000	1450								
Lower (std UC) – 2 sets stabilizers down			*10 400	*10 400	*10 400	*9950	8650	6700	7250	6150	4850	5500	4700	3750	4400	3800	3000								

*Limited by hydraulic rather than tipping load.

Lift capacity ratings are based on ISO 10567:2007, they do not exceed 87% of hydraulic lifting capacity or 75% of tipping load. The load point is the center line of the bucket pivot mounting pin on the stick. The oscillating axle must be locked. Lifting capacities are based on the machine standing on a firm uniform supporting surface. For lifting capacity including bucket and/or quick coupler, the respective weight has to be subtracted from above values. The use of a work tool attachment point to handle/lift objects, could affect the machine lift performance.

Always refer to the appropriate Operation and Maintenance Manual for specific product information.

Lift Capacities

All values are in lb, hydraulic cab riser, work tool: none, with counterweight (9040 lb), heavy lift on.



Undercarriage

Boom

Stick

MH or Standard

22'4" MH

19'4" MH

Stick	Undercarriage configuration	10 ft			15 ft			20 ft			25 ft			30 ft			35 ft			40 ft			ft		
		Load over front	Load over rear	Load over side	Load over front	Load over rear	Load over side	Load over front	Load over rear	Load over side	Load over front	Load over rear	Load over side	Load over front	Load over rear	Load over side	Load over front	Load over rear	Load over side						
40 ft	MH – stabilizers up – solid tires							13,900	13,900	10,500													11,500	11,500	8700
	MH – stabilizers down – solid tires							*15,600	*15,600	*15,600													*12,900	*12,900	*12,900
	Lower (std UC) – f. stabilizer & r. dozer up							13,600	12,900	10,100													11,200	10,700	8300
	Lower (std UC) – f. stabilizer & r. dozer down							*15,600	*15,600	15,100													*12,900	*12,900	12,500
	Lower (std UC) – f. dozer & r. stabilizer up							14,000	12,500	10,100													11,600	10,300	8300
	Lower (std UC) – f. dozer & r. stabilizer down							*15,600	*15,600	15,500													*12,900	*12,900	12,800
	Lower (std UC) – 2 sets stabilizers up							14,000	12,900	10,200													11,500	10,600	8400
Lower (std UC) – 2 sets stabilizers down							*15,600	*15,600	*15,600													*12,900	*12,900	*12,900	
35 ft	MH – stabilizers up – solid tires										9900	9900	7600									7700	7700	5800	
	MH – stabilizers down – solid tires										*15,300	*15,300	15,300									*11,000	*11,000	*11,000	
	Lower (std UC) – f. stabilizer & r. dozer up										9700	9200	7200									7500	7200	5500	
	Lower (std UC) – f. stabilizer & r. dozer down										*15,300	*15,300	10,800									*11,000	*11,000	8400	
	Lower (std UC) – f. dozer & r. stabilizer up										10,000	8900	7200									7800	6900	5500	
	Lower (std UC) – f. dozer & r. stabilizer down										*15,300	*15,300	11,000									*11,000	*11,000	8600	
	Lower (std UC) – 2 sets stabilizers up										9900	9200	7300									7700	7100	5600	
Lower (std UC) – 2 sets stabilizers down										*15,300	*15,300	13,000									*11,000	*11,000	10,100		
30 ft	MH – stabilizers up – solid tires										10,100	10,100	7700	7300	7300	5500						6100	6100	4500	
	MH – stabilizers down – solid tires										*16,300	*16,300	15,500	13,900	13,900	11,300						*10,100	*10,100	9500	
	Lower (std UC) – f. stabilizer & r. dozer up										9900	9400	7400	7100	6800	5300						5900	5600	4200	
	Lower (std UC) – f. stabilizer & r. dozer down										*16,300	*16,300	11,000	13,100	12,900	8000						*10,100	*10,100	6600	
	Lower (std UC) – f. dozer & r. stabilizer up										10,200	9100	7400	7400	6600	5300						6100	5400	4200	
	Lower (std UC) – f. dozer & r. stabilizer down										*16,300	15,700	11,200	*14,300	11,400	8100						*10,100	9600	8800	
	Lower (std UC) – 2 sets stabilizers up										10,100	9400	7500	7300	6800	5300						6100	5600	4300	
Lower (std UC) – 2 sets stabilizers down										*16,300	16,100	13,200	13,500	11,700	9600						*10,100	9800	8000		
25 ft	MH – stabilizers up – solid tires										10,100	10,100	7700	7400	7400	5500	5500	5500	4100			5100	5100	3700	
	MH – stabilizers down – solid tires										*16,300	*16,300	15,500	13,900	13,900	11,400	10,700	10,700	8700			*9700	*9700	8200	
	Lower (std UC) – f. stabilizer & r. dozer up										9800	9400	7400	7200	6800	5300	5300	5100	3800			5000	4700	3500	
	Lower (std UC) – f. stabilizer & r. dozer down										*16,300	*16,300	10,900	13,200	13,000	8000	10,000	9900	6000			9400	9300	5600	
	Lower (std UC) – f. dozer & r. stabilizer up										10,200	9100	7400	7400	6600	5300	5500	4900	3800			5200	4500	3500	
	Lower (std UC) – f. dozer & r. stabilizer down										*16,300	15,600	11,200	*14,500	11,400	8200	11,200	8700	6200			*9700	8200	5700	
	Lower (std UC) – 2 sets stabilizers up										10,100	9300	7400	7400	6800	5300	5500	5100	3900			5100	4700	3600	
Lower (std UC) – 2 sets stabilizers down										*16,300	16,100	13,100	13,500	11,800	9600	10,300	9000	7300			*9700	8400	6000		
20 ft	MH – stabilizers up – solid tires										9800	9800	7500	7200	7200	5400	5500	4000				4600	4600	3300	
	MH – stabilizers down – solid tires										*16,700	*16,700	15,200	13,800	13,800	11,200	10,700	10,700	8700			9000	9000	7200	
	Lower (std UC) – f. stabilizer & r. dozer up										9600	9200	7200	7000	6700	5200	5300	5100	3800			4400	4200	3100	
	Lower (std UC) – f. stabilizer & r. dozer down										*16,700	*16,700	10,700	13,100	12,800	7900	10,000	9900	6000			8500	8400	5000	
	Lower (std UC) – f. dozer & r. stabilizer up										9900	8900	7200	7300	6500	5200	5500	4900	3800			4600	4000	3100	
	Lower (std UC) – f. dozer & r. stabilizer down										*16,700	15,400	11,000	14,600	11,300	8100	11,200	8700	6100			*9500	7400	5100	
	Lower (std UC) – 2 sets stabilizers up										9900	9100	7200	7200	6700	5200	5500	5100	3900			4500	4200	3100	
Lower (std UC) – 2 sets stabilizers down										*16,700	15,800	12,900	13,400	11,600	9500	10,300	9000	7300			8700	7600	6100		
15 ft	MH – stabilizers up – solid tires										13,500	13,500	10,200	9500	9500	7100	7000	7000	5200	5400	5400	3900	4200	4200	3000
	MH – stabilizers down – solid tires										*20,700	*20,700	*20,700	*17,400	*17,400	14,800	13,500	13,500	11,000	10,500	10,500	8500	8400	8400	6800
	Lower (std UC) – f. stabilizer & r. dozer up										13,300	12,600	9900	9200	8800	6800	6800	6500	5000	5200	5000	3700	4000	3900	2800
	Lower (std UC) – f. stabilizer & r. dozer down										*20,700	*20,700	14,800	*17,400	17,000	10,300	12,800	12,600	7600	9900	9800	5900	7900	7900	4600
	Lower (std UC) – f. dozer & r. stabilizer up										13,700	12,200	9900	9500	8500	6900	7100	6300	5000	5400	4800	3700	4200	3700	2800
	Lower (std UC) – f. dozer & r. stabilizer down										*20,700	*20,700	15,200	*17,400	15,000	10,600	14,300	11,100	7800	11,100	8600	6000	8900	6900	4700
	Lower (std UC) – 2 sets stabilizers up										13,600	12,600	9900	9500	8800	6900	7000	6500	5000	5400	4900	3800	4200	3700	2800
Lower (std UC) – 2 sets stabilizers down										*20,700	*20,700	18,000	*17,400	15,400	12,500	13,100	11,400	9300	10,200	8900	7200	8100	7100	5700	

* Limited by hydraulic rather than tipping load.

(continued on next page)

Lift capacity ratings are based on ISO 10567:2007, they do not exceed 87% of hydraulic lifting capacity or 75% of tipping load. The load point is the center line of the bucket pivot mounting pin on the stick. The oscillating axle must be locked. Lifting capacities are based on the machine standing on a firm uniform supporting surface. For lifting capacity including bucket and/or quick coupler, the respective weight has to be subtracted from above values. The use of a work tool attachment point to handle/lift objects, could affect the machine lift performance.

Always refer to the appropriate Operation and Maintenance Manual for specific product information.

Lift Capacities (continued)

All values are in lb, hydraulic cab riser, work tool: none, with counterweight (9040 lb), heavy lift on.

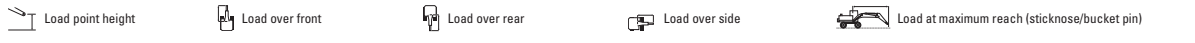

Undercarriage

Boom
22" MH

Stick
19" MH

MH or Standard

Stick ft	Undercarriage configuration	10 ft			15 ft			20 ft			25 ft			30 ft			35 ft			40 ft			ft				
		Load point height	Load over front	Load over rear	Load point height	Load over front	Load over rear	Load point height	Load over front	Load over rear	Load point height	Load over front	Load over rear	Load point height	Load over front	Load over rear	Load point height	Load over front	Load over rear	Load point height	Load over front	Load over rear					
10 ft	MH – stabilizers up – solid tires				19,900	19,900	14,600	12,700	12,700	9,400	9,000	9,000	6,700	6,700	6,700	4,900	5,200	5,200	3,800	4,100	4,100	2,900	4,000	4,000	2,800		
	MH – stabilizers down – solid tires				*28,900	*28,900	*28,900	*22,200	*22,200	20,500	17,700	17,700	14,200	13,200	13,200	10,700	10,300	10,300	8,400	8,400	8,400	6,700	8,100	8,100	6,500		
	Lower (std UC) – f. stabilizer & r. dozer up				19,700	18,400	14,000	12,400	11,700	9,000	8,700	8,300	6,300	6,500	6,200	4,700	5,000	4,800	3,500	4,000	3,800	2,700	3,800	3,700	2,600		
	Lower (std UC) – f. stabilizer & r. dozer down				*28,900	*28,900	22,200	*22,200	*22,200	13,900	16,800	16,400	9,800	12,500	12,200	7,300	9,700	9,600	5,700	7,800	7,700	4,500	7,600	7,500	4,400		
	Lower (std UC) – f. dozer & r. stabilizer up				20,400	17,800	14,000	12,800	11,300	9,000	9,000	8,000	6,300	6,800	6,000	4,700	5,200	4,600	3,500	4,100	3,600	2,700	4,000	3,500	2,600		
	Lower (std UC) – f. dozer & r. stabilizer down				*28,900	*28,900	22,900	*22,200	20,800	14,300	*18,100	14,400	10,000	14,000	10,700	7,500	10,900	8,400	5,900	8,800	6,800	4,700	8,500	6,500	4,500		
5 ft	MH – stabilizers up – solid tires				17,900	17,900	12,800	11,700	11,700	8,500	8,400	8,400	6,100	6,400	6,400	4,600	5,000	5,000	3,600	4,000	4,000	2,800	3,900	3,900	2,700		
	MH – stabilizers down – solid tires				*31,700	*31,700	31,600	*23,300	*23,300	19,300	17,100	17,100	13,600	12,800	12,800	10,300	10,100	10,100	8,200	8,300	8,300	6,700	8,000	8,000	6,400		
	Lower (std UC) – f. stabilizer & r. dozer up				17,600	16,400	12,200	11,400	10,800	8,100	8,200	7,800	5,800	6,200	5,900	4,400	4,800	4,600	3,400	3,900	3,700	2,600	3,700	3,600	2,500		
	Lower (std UC) – f. stabilizer & r. dozer down				*31,700	*31,700	20,000	*23,300	22,800	12,900	16,200	15,800	9,200	12,100	11,900	7,000	9,500	9,400	5,500	7,700	7,600	4,500	7,400	7,400	4,300		
	Lower (std UC) – f. dozer & r. stabilizer up				18,300	15,800	12,200	11,800	10,400	8,100	8,500	7,500	5,800	6,400	5,700	4,400	5,100	4,400	3,400	4,100	3,500	2,600	3,900	3,400	2,500		
	Lower (std UC) – f. dozer & r. stabilizer down				*31,700	*31,700	20,700	*23,300	19,700	13,300	18,200	13,800	9,500	13,600	10,400	7,200	10,700	8,200	5,700	8,700	6,700	4,600	8,400	6,400	4,400		
0 ft	MH – stabilizers up – solid tires				18,200	16,300	12,300	11,800	10,700	8,200	8,400	7,700	5,900	6,400	5,900	4,400	5,000	4,600	3,400	4,000	3,700	2,700	3,900	3,500	2,600		
	MH – stabilizers down – solid tires				*31,700	*31,700	25,500	*23,300	20,300	16,000	16,600	14,200	11,400	12,400	10,700	8,600	9,800	8,500	6,800	8,000	6,900	5,500	7,700	6,700	5,300		
	Lower (std UC) – f. stabilizer & r. dozer up				*9,200	*9,200	*9,200	16,300	16,300	11,300	10,900	7,700	7,900	7,900	5,700	6,100	4,400	4,900	4,900	3,400							
	Lower (std UC) – f. stabilizer & r. dozer down				*9,200	*9,200	*9,200	*31,700	*31,700	25,600	*23,300	18,400	16,500	16,500	13,100	12,500	12,500	10,000	9,900	9,900	8,000						
	Lower (std UC) – f. dozer & r. stabilizer up				*9,200	*9,200	*9,200	16,000	14,900	10,700	10,600	10,000	7,300	7,700	7,300	5,400	5,900	5,600	4,100	4,700	4,500	3,200					
	Lower (std UC) – f. dozer & r. stabilizer down				*9,200	*9,200	*9,200	*31,700	*31,700	18,400	22,400	21,700	12,000	15,600	15,200	8,700	11,800	11,600	6,700	9,300	9,200	5,400					
-5 ft	MH – stabilizers up – solid tires				15,400	15,400	10,500	10,300	10,300	7,200	7,600	7,600	5,300	5,900	5,900	4,100	4,800	4,800	3,300								
	MH – stabilizers down – solid tires				*24,000	*24,000	*24,000	*21,500	*21,500	17,700	16,100	16,100	12,700	12,300	12,300	9,800	9,800	9,800	7,900								
	Lower (std UC) – f. stabilizer & r. dozer up				15,100	14,000	9,900	10,000	9,400	6,800	7,300	6,900	5,000	5,700	5,400	3,900	4,600	4,300	3,100								
	Lower (std UC) – f. stabilizer & r. dozer down				*24,000	*24,000	17,400	*21,500	21,000	11,500	15,200	14,800	8,400	11,500	11,300	6,500	9,200	9,100	5,200								
	Lower (std UC) – f. dozer & r. stabilizer up				15,700	13,400	9,900	10,400	9,000	6,800	7,700	6,600	5,000	5,900	5,200	3,900	4,800	4,100	3,100								
	Lower (std UC) – f. dozer & r. stabilizer down				*24,000	*24,000	18,100	*21,500	18,000	11,800	*16,800	12,800	8,600	13,000	9,800	6,700	*10,100	7,900	5,400								

*Limited by hydraulic rather than tipping load.

Lift capacity ratings are based on ISO 10567:2007, they do not exceed 87% of hydraulic lifting capacity or 75% of tipping load. The load point is the center line of the bucket pivot mounting pin on the stick. The oscillating axle must be locked. Lifting capacities are based on the machine standing on a firm uniform supporting surface. For lifting capacity including bucket and/or quick coupler, the respective weight has to be subtracted from above values. The use of a work tool attachment point to handle/lift objects, could affect the machine lift performance.

Always refer to the appropriate Operation and Maintenance Manual for specific product information.

Lift Capacities

All values are in kg, hydraulic cab riser, work tool: none, with counterweight (5200 kg), heavy lift on.

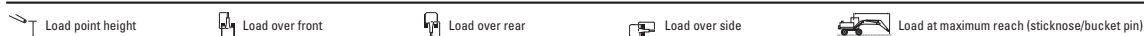

Undercarriage MH or Standard		Boom 6.8 m MH												Stick 5.9 m MH						mm			
		3000 mm			4500 mm			6000 mm			7500 mm			9000 mm			10 500 mm		12 000 mm				
Stick height	Undercarriage configuration	Load over front	Load over rear	Load over side	Load over front	Load over rear	Load over side	Load over front	Load over rear	Load over side	Load over front	Load over rear	Load over side	Load over front	Load over rear	Load over side	Load over front	Load over rear	Load over side	Load at maximum reach			
		12 000 mm	MH – stabilizers up – solid tires																			5400	5400
MH – stabilizers down – solid tires																					*5700	*5700	*5700
Lower (std UC) – f. stabilizer & r. dozer up																					5350	5050	4000
Lower (std UC) – f. stabilizer & r. dozer down																					*7450	*7450	*7450
Lower (std UC) – f. dozer & r. stabilizer up																					*7450	*7450	*7450
Lower (std UC) – f. dozer & r. stabilizer down																					7300	6550	5350
Lower (std UC) – 2 sets stabilizers up																					*7450	*7450	*7450
10 500 mm	MH – stabilizers up – solid tires																				5450	5050	4050
	MH – stabilizers down – solid tires																				*5700	*5700	*5700
	Lower (std UC) – f. stabilizer & r. dozer up																				5200	4700	3850
	Lower (std UC) – f. stabilizer & r. dozer down																				*7250	*7250	5600
	Lower (std UC) – f. dozer & r. stabilizer up																				5200	4800	3900
	Lower (std UC) – f. dozer & r. stabilizer down																				*7250	*7250	5700
	Lower (std UC) – 2 sets stabilizers up																				5200	4800	3900
9000 mm	MH – stabilizers up – solid tires																				*7250	*7250	6700
	MH – stabilizers down – solid tires																				5150	5150	4000
	Lower (std UC) – f. stabilizer & r. dozer up																				*7250	*7250	*7250
	Lower (std UC) – f. stabilizer & r. dozer down																				5050	4850	3850
	Lower (std UC) – f. dozer & r. stabilizer up																				*7250	*7250	5600
	Lower (std UC) – f. dozer & r. stabilizer down																				5200	4700	3850
	Lower (std UC) – 2 sets stabilizers up																				*7250	*7250	5700
7500 mm	MH – stabilizers up – solid tires																				5200	4800	3900
	MH – stabilizers down – solid tires																				*7250	*7250	6700
	Lower (std UC) – f. stabilizer & r. dozer up																				5200	4700	3850
	Lower (std UC) – f. stabilizer & r. dozer down																				*7250	*7250	5700
	Lower (std UC) – f. dozer & r. stabilizer up																				5200	4800	3900
	Lower (std UC) – f. dozer & r. stabilizer down																				*7250	*7250	5700
	Lower (std UC) – 2 sets stabilizers up																				5200	4800	3900
6000 mm	MH – stabilizers up – solid tires																				5200	4800	3900
	MH – stabilizers down – solid tires																				*7250	*7250	6700
	Lower (std UC) – f. stabilizer & r. dozer up																				5200	4800	3900
	Lower (std UC) – f. stabilizer & r. dozer down																				*7250	*7250	6700
	Lower (std UC) – f. dozer & r. stabilizer up																				5200	4800	3900
	Lower (std UC) – f. dozer & r. stabilizer down																				*7250	*7250	6700
	Lower (std UC) – 2 sets stabilizers up																				5200	4800	3900
4500 mm	MH – stabilizers up – solid tires																				5200	4800	3900
	MH – stabilizers down – solid tires																				*7250	*7250	6700
	Lower (std UC) – f. stabilizer & r. dozer up																				5200	4800	3900
	Lower (std UC) – f. stabilizer & r. dozer down																				*7250	*7250	6700
	Lower (std UC) – f. dozer & r. stabilizer up																				5200	4800	3900
	Lower (std UC) – f. dozer & r. stabilizer down																				*7250	*7250	6700
	Lower (std UC) – 2 sets stabilizers up																				5200	4800	3900

* Limited by hydraulic rather than tipping load.

(continued on next page)

Lift capacity ratings are based on ISO 10567:2007, they do not exceed 87% of hydraulic lifting capacity or 75% of tipping load. The load point is the center line of the bucket pivot mounting pin on the stick. The oscillating axle must be locked. Lifting capacities are based on the machine standing on a firm uniform supporting surface. For lifting capacity including bucket and/or quick coupler, the respective weight has to be subtracted from above values. The use of a work tool attachment point to handle/lift objects, could affect the machine lift performance.

Always refer to the appropriate Operation and Maintenance Manual for specific product information.

Lift Capacities (continued)

All values are in kg, hydraulic cab riser, work tool: none, with counterweight (5200 kg), heavy lift on.

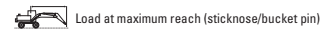
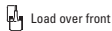

Undercarriage

Boom
6.8 m MH

Stick
5.9 m MH

MH or Standard

Stick height	Undercarriage configuration	3000 mm		4500 mm		6000 mm		7500 mm		9000 mm		10 500 mm		12 000 mm		mm							
		Load point height	Load over front	Load over front	Load over rear	Load over rear	Load over rear	Load over side	Load over side	Load over side	Load over side	Load over side	Load over side	Load over side									
3000 mm	MH – stabilizers up – solid tires			9300	9300	6750	6100	6100	4550	4450	3300	3400	3400	2500	2700	2700	2000	2200	2200	1600	2100	1500	
	MH – stabilizers down – solid tires			*13 350	*13 350	*13 350	*10 250	*10 250	*10 250	*8350	*8350	7300	6750	6750	5500	5300	5300	4300	4300	4300	3500	4050	3300
	Lower (std UC) – f. stabilizer & r. dozer up			10 200	9500	7350	6450	6100	4750	4600	4350	3400	3450	3300	2550	2700	2600	1950	2150	2050	1550	2050	1450
	Lower (std UC) – f. stabilizer & r. dozer down			*13 350	*13 350	11 400	*10 250	*10 250	7200	*8350	*8350	5100	6400	6250	3850	5000	4950	3050	4050	4000	2450	3850	3800
	Lower (std UC) – f. dozer & r. stabilizer up			10 500	9250	7350	6650	5900	4750	4750	4200	3400	3550	3200	2550	2800	2500	1950	2250	2000	1550	2100	1850
	Lower (std UC) – f. dozer & r. stabilizer down			*13 350	*13 350	11 800	*10 250	*10 250	7400	*8350	7400	5250	*7000	5550	3950	5600	4350	3100	4500	3550	2500	4250	3350
1500 mm	MH – stabilizers up – solid tires			9300	9300	6750	6100	6100	4550	4450	3300	3400	3400	2500	2700	2700	2000	2200	2200	1600	2050	1500	
	MH – stabilizers down – solid tires			*14 600	*14 600	*14 600	*10 750	*10 750	9900	*8500	*8500	7000	6550	6550	5350	5200	5200	4250	4250	3450	4000	4000	3250
	Lower (std UC) – f. stabilizer & r. dozer up			9250	8600	6500	6000	5650	4350	4350	4100	3150	3300	3150	2400	2600	2500	1900	2100	2000	1500	2000	1400
	Lower (std UC) – f. stabilizer & r. dozer down			*14 600	*14 600	10 400	*10 750	*10 750	6750	8300	8100	4850	6250	6100	3700	4900	4850	2950	4000	3950	2400	3800	3750
	Lower (std UC) – f. dozer & r. stabilizer up			9550	8300	6500	6200	5450	4350	4500	3950	3150	3400	3050	2400	2700	2400	1900	2200	1950	1500	2050	1800
	Lower (std UC) – f. dozer & r. stabilizer down			*14 600	*14 600	10 800	*10 750	*10 150	6900	*8500	7100	4950	6950	5400	3800	5500	4250	3000	4450	3000	2450	*4000	3300
0 mm	MH – stabilizers up – solid tires			9300	9300	6750	6100	6100	4550	4450	3300	3400	3400	2500	2700	2700	2000	2200	2200	1600	2050	1500	
	MH – stabilizers down – solid tires			*14 600	*14 600	13 200	*10 750	*10 400	8250	8500	7300	5900	6400	5550	4500	5050	4400	3550	4100	3600	2900	3900	3400
	Lower (std UC) – f. stabilizer & r. dozer up			*4050	*4050	*4050	8600	8600	6100	5700	4150	4200	4200	3100	3250	3250	2400	2600	2600	1900	2150	2150	1550
	Lower (std UC) – f. stabilizer & r. dozer down			*4050	*4050	*4050	*14 600	*14 600	*10 750	*10 750	9450	*8400	*8400	6750	6400	6400	5200	5100	5100	4150	*4000	*4000	3400
	Lower (std UC) – f. dozer & r. stabilizer up			*4050	*4050	*4050	8500	7850	5800	5600	5300	3950	4100	3900	2950	3150	3000	2250	2550	2400	1800	2100	2000
	Lower (std UC) – f. dozer & r. stabilizer down			*4050	*4050	*4050	*14 600	*14 600	9650	*10 750	*10 750	6350	8050	7850	4600	8050	5950	3550	4800	4750	2850	3950	3900
-1500 mm	MH – stabilizers up – solid tires			8200	8200	5750	5450	5450	3950	4050	4050	2950	3150	3150	2200	2550	2550	1850	2150	1950	1500	1900	1400
	MH – stabilizers down – solid tires			*10 400	*10 400	*10 400	*9950	*9950	9150	*7750	*7750	6550	*6150	*6150	5950	*4750	*4750	4100	4100	3400	4000	4000	3250
	Lower (std UC) – f. stabilizer & r. dozer up			8100	7500	5450	5350	5050	3750	3950	3750	2800	3050	2900	2150	2450	2350	1750	1950	1850	1400	1850	1400
	Lower (std UC) – f. stabilizer & r. dozer down			*10 400	*10 400	9250	*9950	*9950	6050	*7750	7650	4450	5950	5850	3450	*4750	4700	2800	3400	3400	2450	3850	3800
	Lower (std UC) – f. dozer & r. stabilizer up			8400	7200	5450	5550	4950	3750	4100	3600	2800	3200	2800	2150	2550	2250	1750	1950	1850	1400	1850	1400
	Lower (std UC) – f. dozer & r. stabilizer down			*10 400	*10 400	9550	*9950	9350	6250	*7750	6650	4550	*6150	5100	3550	*4750	4100	2850	3400	3400	2450	3850	3800

*Limited by hydraulic rather than tipping load.

Lift capacity ratings are based on ISO 10567:2007, they do not exceed 87% of hydraulic lifting capacity or 75% of tipping load. The load point is the center line of the bucket pivot mounting pin on the stick. The oscillating axle must be locked. Lifting capacities are based on the machine standing on a firm uniform supporting surface. For lifting capacity including bucket and/or quick coupler, the respective weight has to be subtracted from above values. The use of a work tool attachment point to handle/lift objects, could affect the machine lift performance.

Always refer to the appropriate Operation and Maintenance Manual for specific product information.

Lift Capacities

All values are in lb, hydraulic cab riser, work tool: none, with counterweight (11,470 lb), heavy lift on.



Undercarriage

Boom
22'4" MH

Stick
19'4" MH

MH or Standard

Stick	Undercarriage configuration	10 ft			15 ft			20 ft			25 ft			30 ft			35 ft			40 ft			ft					
		Load point height	Load over front	Load over rear	Load over front	Load over rear	Load over side	Load over front	Load over rear	Load over side	Load over front	Load over rear	Load over side	Load over front	Load over rear	Load over side	Load over front	Load over rear	Load over side	Load over front	Load over rear	Load over side						
40 ft	MH – stabilizers up – solid tires									15,300	15,300	11,800											12,700	12,700	9800			
	MH – stabilizers down – solid tires									*15,600	*15,600	*15,600											*12,900	*12,900	*12,900			
	Lower (std UC) – f. stabilizer & r. dozer up									15,200	14,300	11,400											12,600	11,900	9400			
	Lower (std UC) – f. stabilizer & r. dozer down									*15,600	*15,600	*15,600											*12,900	*12,900	*12,900			
	Lower (std UC) – f. dozer & r. stabilizer up									*15,600	13,900	11,400											*12,900	11,600	9400			
	Lower (std UC) – f. dozer & r. stabilizer down									*15,600	*15,600	*15,600											*12,900	*12,900	*12,900			
	Lower (std UC) – 2 sets stabilizers up									15,500	14,300	11,500											*12,900	11,300	9500			
Lower (std UC) – 2 sets stabilizers down									*15,600	*15,600	*15,600											*12,900	*12,900	*12,900				
35 ft	MH – stabilizers up – solid tires												11,000	11,000	8500										8700	8700	6600	
	MH – stabilizers down – solid tires									*15,300	*15,300	*15,300											*11,000	*11,000	*11,000			
	Lower (std UC) – f. stabilizer & r. dozer up									10,800	10,300	8200											8500	8100	6300			
	Lower (std UC) – f. stabilizer & r. dozer down									*15,300	*15,300	*15,300											*11,000	*11,000	9400			
	Lower (std UC) – f. dozer & r. stabilizer up									11,200	10,000	8200											8700	7800	6300			
	Lower (std UC) – f. dozer & r. stabilizer down									*15,300	*15,300	12,200											*11,000	*11,000	9600			
	Lower (std UC) – 2 sets stabilizers up									11,100	10,300	8300											8700	8000	6400			
Lower (std UC) – 2 sets stabilizers down									*15,300	*15,300	14,300											*11,000	*11,000	*11,000				
30 ft	MH – stabilizers up – solid tires												11,200	11,200	8700	8200	8200	6300							6900	6900	5200	
	MH – stabilizers down – solid tires									*16,300	*16,300	*16,300	*14,300	*14,300	12,500								*10,100	*10,100	*10,100			
	Lower (std UC) – f. stabilizer & r. dozer up									11,000	10,500	8400	8100	7700	6100								6700	6400	5000			
	Lower (std UC) – f. stabilizer & r. dozer down									*16,300	*16,300	12,200	*14,300	14,200	8900								*10,100	*10,100	7500			
	Lower (std UC) – f. dozer & r. stabilizer up									11,300	10,200	8400	8300	7400	6100								6900	6200	5000			
	Lower (std UC) – f. dozer & r. stabilizer down									*16,300	*16,300	12,400	*14,300	12,600	9100								*10,100	*10,100	7600			
	Lower (std UC) – 2 sets stabilizers up									11,300	10,500	8500	8300	7700	6100								6900	6400	5000			
Lower (std UC) – 2 sets stabilizers down									*16,300	*16,300	14,500	*14,300	12,900	10,700								*10,100	*10,100	8900				
25 ft	MH – stabilizers up – solid tires												11,200	11,200	8700	8300	8300	6500	6300	4700					5900	5900	4400	
	MH – stabilizers down – solid tires									*16,300	*16,300	*16,300	*14,500	*14,500	12,500	11,700	11,700	9600					*9700	*9700	9100			
	Lower (std UC) – f. stabilizer & r. dozer up									11,000	10,500	8400	8100	7700	6100	6100	5800	4500					5700	5400	4200			
	Lower (std UC) – f. stabilizer & r. dozer down									*16,300	*16,300	12,100	14,500	14,200	9000	11,100	10,900	6800					*9700	*9700	6400			
	Lower (std UC) – f. dozer & r. stabilizer up									11,300	10,200	8400	8300	7500	6100	6300	5600	4500					5900	5200	4200			
	Lower (std UC) – f. dozer & r. stabilizer down									*16,300	*16,300	12,400	*14,500	12,600	9200	*11,900	9700	7000					*9700	9100	6500			
	Lower (std UC) – 2 sets stabilizers up									11,300	10,400	8400	8300	7700	6100	6300	5800	4600					5900	5400	4200			
Lower (std UC) – 2 sets stabilizers down									*16,300	*16,300	14,500	*14,500	13,000	10,700	11,400	10,000	8200					*9700	9400	7100				
20 ft	MH – stabilizers up – solid tires												11,000	11,000	8500	8100	8100	6200	6300	4700					5200	5200	3900	
	MH – stabilizers down – solid tires									*16,700	*16,700	16,700	*14,700	*14,700	12,400	11,700	11,700	9600					*9500	*9500	8200			
	Lower (std UC) – f. stabilizer & r. dozer up									10,800	10,300	8100	8000	7500	6000	6100	5900	4500					5100	4900	3700			
	Lower (std UC) – f. stabilizer & r. dozer down									*16,700	*16,700	11,900	14,400	14,100	8800	11,100	10,900	6800					9400	9300	5700			
	Lower (std UC) – f. dozer & r. stabilizer up									11,100	10,000	8100	8200	7400	6000	6300	5500	4500					5300	4700	3700			
	Lower (std UC) – f. dozer & r. stabilizer down									*16,700	*16,700	12,200	*14,700	12,500	9000	12,300	9700	6900					*9500	8200	5800			
	Lower (std UC) – 2 sets stabilizers up									11,000	10,200	8200	8200	7600	6000	6300	5900	4500					5200	4800	3700			
Lower (std UC) – 2 sets stabilizers down									*16,700	*16,700	14,200	*14,700	12,800	10,600	11,400	9900	8200					*9500	8500	6900				
15 ft	MH – stabilizers up – solid tires												15,000	15,000	11,500	10,600	10,600	8100	7900	7900	6000	6100	6100	4800		4900	4900	3600
	MH – stabilizers down – solid tires									*20,700	*20,700	*20,700	*17,400	*17,400	16,200	14,800	14,800	12,100	11,600	11,600	9500				9300	9300	7600	
	Lower (std UC) – f. stabilizer & r. dozer up									14,800	14,000	11,100	10,400	9900	7900	7700	7400	5900	6000	5700	4400				4700	4500	3400	
	Lower (std UC) – f. stabilizer & r. dozer down									*20,700	*20,700	16,400	*17,400	*17,400	11,500	14,100	13,800	8600	11,000	10,800	6700				8800	8700	5300	
	Lower (std UC) – f. dozer & r. stabilizer up									15,300	13,600	11,100	10,700	9600	7900	8000	7100	5900	6200	5500	4400				4900	4300	3400	
	Lower (std UC) – f. dozer & r. stabilizer down									*20,700	*20,700	16,900	*17,400	16,500	11,800	*14,900	12,300	9600	8800	12,200	9600	6800				*9500	7700	5400
	Lower (std UC) – 2 sets stabilizers up									15,200	14,000	11,200	10,600	9800	7900	7900	7300	5900	6100	5700	4400				4900	4900	3400	
Lower (std UC) – 2 sets stabilizers down									*20,700	*20,700	19,900	*17,400	16,900	13,800	14,400	12,600	10,300	11,200	9800	8100				8000	7900	6400		

* Limited by hydraulic rather than tipping load.

(continued on next page)

Lift capacity ratings are based on ISO 10567:2007, they do not exceed 87% of hydraulic lifting capacity or 75% of tipping load. The load point is the center line of the bucket pivot mounting pin on the stick. The oscillating axle must be locked. Lifting capacities are based on the machine standing on a firm uniform supporting surface. For lifting capacity including bucket and/or quick coupler, the respective weight has to be subtracted from above values. The use of a work tool attachment point to handle/lift objects, could affect the machine lift performance.

Always refer to the appropriate Operation and Maintenance Manual for specific product information.

Lifting Capacities ● MH3024 (Grenoble Sourced)

Material Handlers

Lift Capacities (continued)

All values are in lb, hydraulic cab riser, work tool: none, with counterweight (11,470 lb), heavy lift on.

		Load point height	Load over front	Load over rear	Load over side	Load at maximum reach (sticknose/bucket pin)																			
		Undercarriage					Boom					Stick													
		MH or Standard					22'4" MH					19'4" MH													
	Undercarriage configuration	10 ft			15 ft			20 ft			25 ft			30 ft			35 ft			40 ft			ft		
10 ft	MH – stabilizers up – solid tires				22,100	22,100	16,500	14,100	14,100	10,700	10,100	10,100	7600	7600	7600	5700	6000	6000	4400	4800	4800	3500	4600	4600	3400
	MH – stabilizers down – solid tires				*28,900	*28,900	*28,900	*22,200	*22,200	*22,200	*18,100	*18,100	15,700	14,500	14,500	11,800	11,400	11,400	9300	9200	9200	7500	9000	9000	7300
	Lower (std UC) – f. stabilizer & r. dozer up				22,000	20,500	15,800	13,900	13,200	10,300	9900	9400	7300	7400	7100	5500	5800	5500	4200	4600	4400	3300	4500	4300	3200
	Lower (std UC) – f. stabilizer & r. dozer down				*28,900	*28,900	24,600	*22,200	*22,200	15,500	*18,100	18,000	11,000	13,800	13,500	8300	10,800	10,600	6500	8700	8600	5200	8500	8300	5100
	Lower (std UC) – f. dozer & r. stabilizer up				22,600	19,900	15,800	14,400	12,800	10,300	10,200	9100	7300	7700	6800	5500	6000	5300	4200	4800	4200	3300	4700	4100	3200
	Lower (std UC) – f. dozer & r. stabilizer down				*28,900	*28,900	25,400	*22,200	*22,200	15,900	*18,100	15,900	11,300	*15,100	11,900	8500	12,000	9400	6700	9700	7600	5300	9400	7400	5200
5 ft	Lower (std UC) – 2 sets stabilizers up				22,500	20,400	16,000	14,300	13,100	10,400	10,100	9400	7400	7600	7100	5500	6000	5500	4300	4800	4400	3300	4600	4200	3200
	Lower (std UC) – 2 sets stabilizers down				*28,900	*28,900	*28,900	*22,200	*22,200	18,900	*18,100	16,300	13,300	14,100	12,300	10,000	11,100	9600	7900	9000	7800	6400	8700	7600	6200
	MH – stabilizers up – solid tires				20,100	20,100	14,600	13,200	13,200	9800	9500	9500	7100	7300	7300	5400	5800	5800	4300	4700	4700	3400	4500	4500	3300
	MH – stabilizers down – solid tires				*31,700	*31,700	*31,700	*23,300	*23,300	21,300	*18,500	*18,500	15,100	14,100	14,100	11,500	11,200	11,200	9100	9200	9200	7500	8800	8800	7200
	Lower (std UC) – f. stabilizer & r. dozer up				19,900	18,500	14,000	13,000	12,200	9400	9300	8900	6800	7100	6800	5200	5600	5400	4000	4500	4300	3200	4400	4200	3100
	Lower (std UC) – f. stabilizer & r. dozer down				*31,700	*31,700	22,400	*23,300	*23,300	14,500	17,800	17,400	10,400	13,400	13,100	8000	10,600	10,400	6300	8600	8500	5100	8300	8200	5000
0 ft	Lower (std UC) – f. dozer & r. stabilizer up				20,600	17,900	14,000	13,400	11,800	9400	9700	8600	6800	7400	6500	5200	5800	5200	4000	4700	4200	3200	4600	4000	3100
	Lower (std UC) – f. dozer & r. stabilizer down				*31,700	*31,700	23,200	*23,300	21,800	14,900	*18,500	15,300	10,700	15,000	11,600	8200	11,800	9200	6500	*9600	6700	5300	*8900	7200	5100
	Lower (std UC) – 2 sets stabilizers up				20,400	18,400	14,100	13,300	12,200	9500	9600	8800	6900	7300	6700	5200	5800	5300	4100	4700	4300	3300	4500	4100	3100
	Lower (std UC) – 2 sets stabilizers down				*31,700	*31,700	28,300	*23,300	22,300	17,800	18,300	15,700	12,700	13,700	11,900	9700	10,900	9400	7700	8900	7700	6300	8600	7500	6000
	MH – stabilizers up – solid tires	*9200	*9200	*9200	18,500	18,500	13,200	12,300	12,300	9000	9100	9100	6700	7000	7000	5200	5600	5600	4100						
	MH – stabilizers down – solid tires	*9200	*9200	*9200	*31,700	*31,700	*31,700	*23,300	*23,300	20,400	*18,200	*18,200	14,500	13,800	13,800	11,200	11,000	11,000	8900						
-5 ft	Lower (std UC) – f. stabilizer & r. dozer up				17,400	16,100	11,800	11,500	10,800	8100	8500	8000	6000	6600	6300	4700	5300	5100	3800						
	Lower (std UC) – f. stabilizer & r. dozer down				*24,000	*24,000	19,800	*21,500	*21,500	13,100	*16,800	16,400	9600	12,800	12,600	7500	*10,100	*10,100	6000						
	Lower (std UC) – f. dozer & r. stabilizer up				18,000	15,500	11,800	12,000	10,400	8100	8800	7700	6000	6900	6000	4700	5500	4900	3800						
	Lower (std UC) – f. dozer & r. stabilizer down				*24,000	*24,000	20,600	*21,500	20,100	13,400	*16,800	14,300	9800	*13,200	11,000	7700	*10,100	8900	6200						
	Lower (std UC) – 2 sets stabilizers up				17,900	16,000	11,900	11,900	10,800	8200	8800	8000	6100	6800	6200	4700	5500	5000	3800						
	Lower (std UC) – 2 sets stabilizers down				*24,000	*24,000	24,000	*21,500	20,700	16,300	*16,800	14,800	11,800	13,200	11,400	9100	*10,100	9100	7400						

9

*Limited by hydraulic rather than tipping load.

Lift capacity ratings are based on ISO 10567:2007, they do not exceed 87% of hydraulic lifting capacity or 75% of tipping load. The load point is the center line of the bucket pivot mounting pin on the stick. The oscillating axle must be locked. Lifting capacities are based on the machine standing on a firm uniform supporting surface. For lifting capacity including bucket and/or quick coupler, the respective weight has to be subtracted from above values. The use of a work tool attachment point to handle/lift objects, could affect the machine lift performance.

Always refer to the appropriate Operation and Maintenance Manual for specific product information.

MH3037 Range Diagram

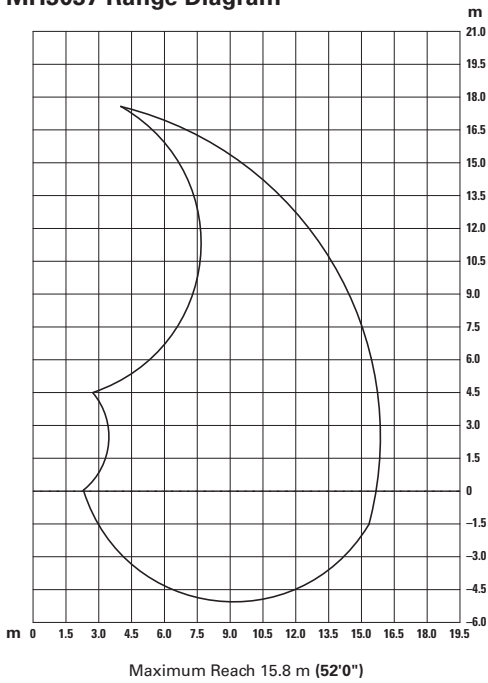

MH3037 Specifications

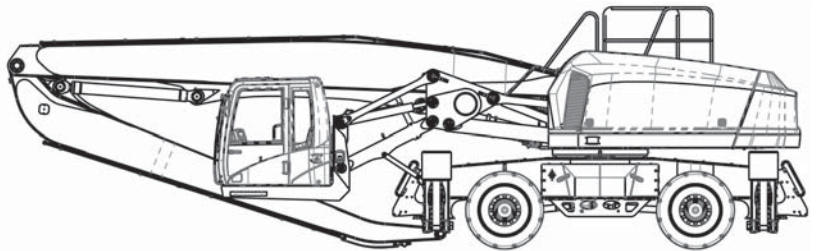
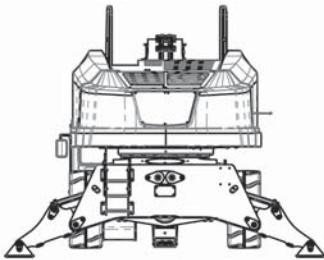

Model

MH3037

Operating Weight	37 420 kg	82,500 lb
Horsepower (Net)	168 kW	225 hp
Boom Length	8840 mm	29'0"
Stick Length	7417 mm	24'4"
Maximum Horizontal Reach	15 800 mm	52'0"
Maximum Vertical Pin Height	17 700 mm	58'0"
Maximum Depth	4900 mm	16'0"
Eye Level Height (Cab Fully Raised)	5500 mm	18'0"
Transport Width	3207 mm	10'6"
Transport Height	3334 mm	10'11"
Transport Length	12 560 mm	41'2"

MH3037 Lift Capacities

		3.0 m 10 ft	4.5 m 15 ft	6.0 m 20 ft	7.5 m 25 ft	9.0 m 30 ft	10.5 m 35 ft	12.0 m 40 ft	13.5 m 45 ft	15.0 m 50 ft	Maximum Reach		
												Lift	Distance
16.5 m 55.0 ft	kg lb												
15.0 m 50.0 ft	kg lb			8970									
13.5 m 45.0 ft	kg lb			8340 18,340	7290	6610							
12.0 m 40.0 ft	kg lb			17,660	7060 15,460	6360	5850						
10.5 m 35.0 ft	kg lb				7050 15,380	6310 13,770	5750 12,560						
9.0 m 30.0 ft	kg lb			8370 18,170	7230 15,710	6400 13,930	5770 12,560	5260 11,470					
7.5 m 25.0 ft	kg lb			8950 19,370	7570 16,420	6600 14,330	5870 12,750	5290 11,500	4780				
6.0 m 20.0 ft	kg lb	16 810 35,210	12 690 27,510	9780 21,140	8040 17,410	6870 14,890	6010 13,050	5350 11,610	4770 10,340		4570 10,120	14.0 m 45'10"	
4.5 m 15.0 ft	kg lb		14 660 31,550	10 730 23,180	8550 18,510	7150 15,500	6170 13,370	5410 11,730	4760 10,300		4400 9740	14.3 m 46'10"	
3.0 m 10.0 ft	kg lb		5470 13,620	11 500 24,850	8980 19,430	7390 16,010	6280 13,610	5440 11,780	4720 10,180		4250 9380	14.4 m 47'3"	
1.5 m 5.0 ft	kg lb		3610 8530	11 770 25,490	9180 19,880	7500 16,240	6310 13,670	5400 11,670	4600 9880		4060 8990	14.4 m 47'2"	
0.0 m 0.0 ft	kg lb		4130 9500	9700 22,660	9060 19,640	7410 16,040	6200 13,410	5240 11,300	4350 9280		3850 8530	14.2 m 46'6"	
-1.5 m -5.0 ft	kg lb			9550 22,000	8580 18,600	7070 15,290	5890 12,710	4900 10,520	3880				
-3.0 m -10.0 ft	kg lb				7720 16,700	6420 13,860	5320 11,430						
-4.5 m -15.0 ft	kg lb												

Note: Lift capacities are calculated with outriggers deployed.
Rated loads do not exceed 87% of hydraulic lifting capacity or 75% of tipping capacity.
Lifting capacities are calculated without worktool installed.

MH3037 Lift Capacities

		3.0 m 10 ft	4.5 m 15 ft	6.0 m 20 ft	7.5 m 25 ft	9.0 m 30 ft	10.5 m 35 ft	12.0 m 40 ft	13.5 m 45 ft	15.0 m 50 ft	Maximum Reach		
												Lift	Distance
16.5 m 55.0 ft	kg lb			7900 16,010									
15.0 m 50.0 ft	kg lb				6810 15,060	6190 11,950							
13.5 m 45.0 ft	kg lb				6440 14,170	5860 12,880	5430 11,980						
12.0 m 40.0 ft	kg lb					5710 12,510	5270 11,560	4930 10,820					
10.5 m 35.0 ft	kg lb					5700 12,440	5230 11,440	4850 10,610	4450				
9.0 m 30.0 ft	kg lb				6440 14,020	5800 12,640	5290 11,520	4860 10,600	4490 9800				
7.5 m 25.0 ft	kg lb				6770 14,710	6000 13,070	5410 11,780	4920 10,720	4510 9810				
6.0 m 20.0 ft	kg lb			8580 18,570	7260 15,730	6310 13,690	5590 12,150	5020 10,910	4540 9870	4100 8860	3800 8320	15.5 m 50'8"	
4.5 m 15.0 ft	kg lb	14 030 29,080	12 540 27,010	9590 20,730	7830 16,960	6650 14,420	5790 12,570	5130 11,140	4590 9950	4090 8820	3810 8370	15.7 m 51'7"	
3.0 m 10.0 ft	kg lb		14 620 31,530	10 590 22,900	8390 18,160	6970 15,110	5980 12,970	5230 11,330	4610 9990	4050 8710	3660 8080	15.9 m 52'0"	
1.5 m 5.0 ft	kg lb		6990 16,600	11 360 24,580	8800 19,060	7220 15,630	6110 13,240	5280 11,430	4600 9930	3950 8470	3510 7760	15.8 m 51'11"	
0.0 m 0.0 ft	kg lb	2150 4890	5220 12,220	11 580 25,070	9020 19,540	7310 15,820	6140 13,280	5240 11,330	4500 9690	3760 7990	3330 7380	15.7 m 51'4"	
-1.5 m -5.0 ft	kg lb	3110 7000	5380 12,200	10 530 24,380	8880 19,200	7190 15,560	6010 12,990	5080 10,960	5280 9170	3400 7060	3110 6860	15.4 m 50'4"	
-3.0 m -10.0 ft	kg lb		6030 16,640	10 110 22,590	8380 18,130	6880 14,740	5690 12,250	4740 10,180	3870 8190				
-4.5 m -15.0 ft	kg lb				7510 16,190	6210 13,360	5100 10,920						

Note: Lift capacities are calculated with outriggers deployed.
 Rated loads do not exceed 87% of hydraulic lifting capacity or 75% of tipping capacity.
 Lifting capacities are calculated without worktool installed.

MH3049 Range Diagram

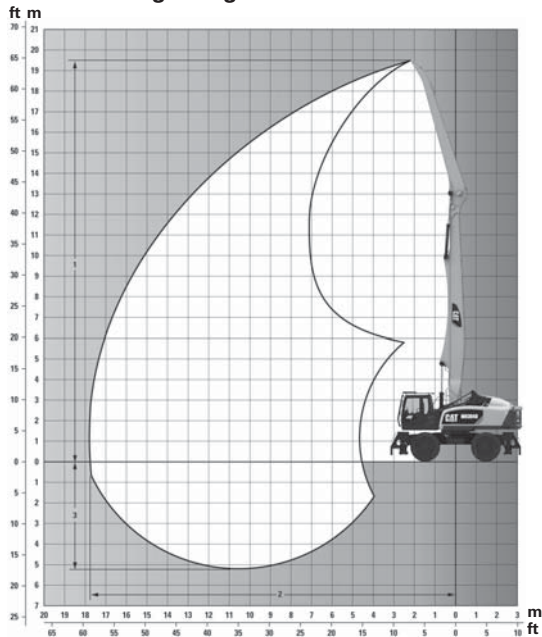

Maximum Reach 17.8 m (58'5")

MH3049 Specifications

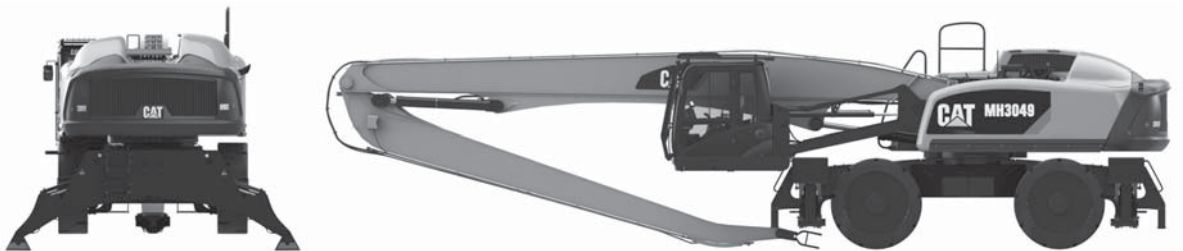

Model

MH3049

Operating Weight	50 349 kg	111,000 lb
Horsepower (Net)	224 kW	300 hp
Boom Length	10 668 mm	35'0"
Stick Length	8001 mm	26'3"
Maximum Horizontal Reach	17 805 mm	58'5"
Maximum Vertical Pin Height	19 507 mm	64'0"
Maximum Depth	5300 mm	17'4"
Eye Level Height (Cab Fully Raised)	5700 mm	18'8"
Transport Width	3321 mm	10'11"
Transport Height	3582 mm	11'9"
Transport Length	14 402 mm	47'3"

MH3049 Lift Capacities

		4.5 m 15 ft	6.0 m 20 ft	7.5 m 25 ft	9.0 m 30 ft	10.5 m 35 ft	12.0 m 40 ft	13.5 m 45 ft	15.0 m 50 ft	16.5 m 55 ft
18.0 m 60.0 ft	kg lb			6400 14,110						
16.5 m 55.0 ft	kg lb				6480 14,290	5100 11,250				
15.0 m 50.0 ft	kg lb				7300 16,090	6420 14,160	11,110			
13.5 m 45.0 ft	kg lb				7800 17,190	7000 15,440	6250 13,780	4660 10,280		
12.0 m 40.0 ft	kg lb				7810 17,230	7130 15,720	6410 14,130	5800 12,790		
10.5 m 35.0 ft	kg lb				8090 17,840	7790 17,170	7160 15,780	6150 13,570	5180 11,430	
9.0 m 30.0 ft	kg lb			9370 20,670	8880 19,590	8140 17,950	7340 16,180	6530 14,390	5550 12,230	
7.5 m 25.0 ft	kg lb		10 360 22,840	10 070 22,200	9500 20,950	8370 18,460	7480 16,490	6590 14,520	5770 12,730	4780 10,530
6.0 m 20.0 ft	kg lb	12 350 27,240	12 780 28,180	11 700 25,790	9930 21,900	8640 19,050	7640 16,850	6650 14,660	5790 12,770	5060 11,150
4.5 m 15.0 ft	kg lb	20 940 46,180	15 540 34,260	12 410 27,370	10 360 22,840	8900 19,620	7790 17,180	6700 14,770	5800 12,780	5170 11,400
3.0 m 10.0 ft	kg lb	5020 11,070	16 540 36,460	12 990 28,650	10 710 23,610	9100 20,070	7900 17,420	6710 14,800	5760 12,700	5090 11,220
1.5 m 5.0 ft	kg lb	2580 5690	8500 18,740	13 280 29,280	10 880 24,000	9190 20,270	7920 17,470	6670 14,700	5670 12,510	4950 10,910
0.0 m 0.0 ft	kg lb	2540 5600	5960 13,150	13 170 29,030	10 820 23,860	9120 20,110	7820 17,250	6530 14,400	5500 12,120	4710 10,390
-1.5 m -5.0 ft	kg lb	3030 6690	5550 12,230	10 950 24,150	10 470 23,090	8840 19,500	7570 16,680	6050 13,330	5200 11,470	4340 9570
-3.0 m -10.0 ft	kg lb		5760 12,710	10 010 22,070	9800 21,610	8320 18,350	7100 15,660	5620 12,390	4740 10,460	
-4.5 m -15.0 ft	kg lb				8790 19,370	7500 16,540	6380 14,070			

Note: Lift capacities are calculated with outriggers deployed.
Rated loads do not exceed 87% of hydraulic lifting capacity or 75% of tipping capacity.

MH3059 Range Diagram

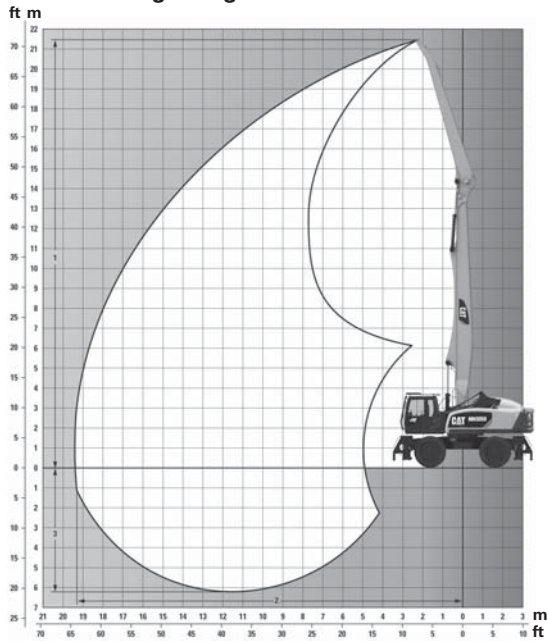

Maximum Reach 19.3 m (63'5")

MH3059 Specifications

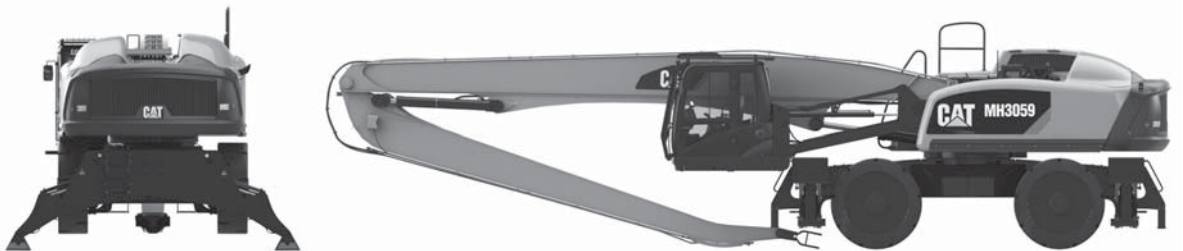

Model

MH3059

Operating Weight	58 967 kg	130,000 lb
Horsepower (Net)	242 kW	325 hp
Boom Length	10 795 mm	35'5"
Stick Length	8992 mm	29'6"
Maximum Horizontal Reach	19 324 mm	63'5"
Maximum Vertical Pin Height	21 463 mm	70'5"
Maximum Depth	6300 mm	20'7"
Eye Level Height (Cab Fully Raised)	7200 mm	23'6"
Transport Width	3632 mm	11'11"
Transport Height	4096 mm	13'5"
Transport Length	14 542 mm	47'9"

MH3059 Lift Capacities

		3.0 m 10 ft	4.5 m 15 ft	6.0 m 20 ft	7.5 m 25 ft	9.0 m 30 ft	10.5 m 35 ft	12.0 m 40 ft	13.5 m 45 ft	15.0 m 50 ft	16.5 m 55 ft	18.0 m 60 ft
19.5 m 65.0 ft	kg lb				10 200 22,490	8340 18,400						
18.0 m 60.0 ft	kg lb					8960 19,760	7660 16,880					
16.5 m 55.0 ft	kg lb						8040 17,720	7160 15,790				
15.0 m 50.0 ft	kg lb						7960 17,560	7520 16,580	6880 15,170			
13.5 m 45.0 ft	kg lb						7870 17,360	7410 16,350	7030 15,510	6480 14,290		
12.0 m 40.0 ft	kg lb						7940 17,500	7440 16,400	7020 15,470	6660 14,690	5960 13,140	
10.5 m 35.0 ft	kg lb					8810 19,430	8140 17,950	7570 16,700	7090 15,630	6680 14,730	6220 13,710	
9.0 m 30.0 ft	kg lb					9290 20,480	8480 18,690	7800 17,210	7220 15,920	6770 14,930	6360 14,030	5300 11,690
7.5 m 25.0 ft	kg lb				10 800 23,810	9940 21,920	8930 19,690	8120 17,910	7460 16,450	6910 15,230	6440 14,190	5870 12,940
6.0 m 20.0 ft	kg lb			13 490 29,740	12 440 27,440	10 740 23,680	9470 20,890	8500 18,740	7710 17,010	7070 15,600	6530 14,400	6000 13,240
4.5 m 15.0 ft	kg lb		23 430 51,670	17 810 39,270	13 800 30,430	11 610 25,610	10 060 22,190	8900 19,630	7990 17,620	7260 16,000	6640 14,640	6000 13,240
3.0 m 10.0 ft	kg lb		8130 17,920	20 000 44,100	15 120 33,350	12 470 27,500	10 640 23,460	9300 20,500	8260 18,210	7430 16,380	6730 14,840	6090 13,430
1.5 m 5.0 ft	kg lb		3290 7250	12 260 27,030	16 210 35,750	13 200 29,110	11 140 24,560	9640 21,250	8490 18,720	7570 16,690	6780 14,960	6060 13,360
0.0 m 0.0 ft	kg lb	890 1980	3070 6770	7750 17,090	16 920 37,310	13 720 30,250	11 510 25,370	9890 21,800	8640 19,060	7640 16,850	6780 14,950	5940 13,100
-1.5 m -5.0 ft	kg lb		3630 8010	7010 15,460	14 790 32,620	13 960 30,790	11 690 25,770	10 000 22,050	8680 19,150	7610 16,780	6670 14,700	5680 12,530
-3.0 m -10.0 ft	kg lb		4450 9820	7250 15,990	13 050 28,780	13 880 30,610	11 630 25,650	9930 21,890	8580 18,910	7440 16,400	6390 14,090	
-4.5 m -15.0 ft	kg lb				7900 17,410	12 880 28,390	13 440 29,630	11 300 24,910	9620 21,220	8250 18,200	7050 15,550	
-6.0 m -20.0 ft	kg lb						12 580 27,730	10 610 23,400	9010 19,860			

Note: Lift capacities are calculated with outriggers deployed.
 Rated loads do not exceed 87% of hydraulic lifting capacity or 75% of tipping capacity.

385C MH Range Diagrams

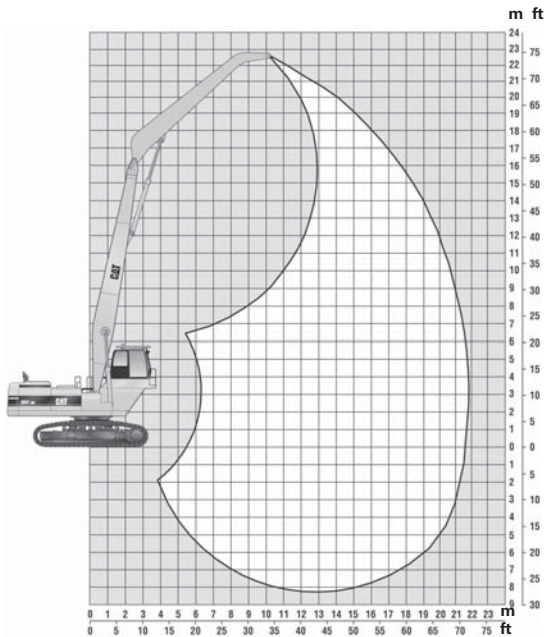

Maximum Reach 21.8 m (71'6")

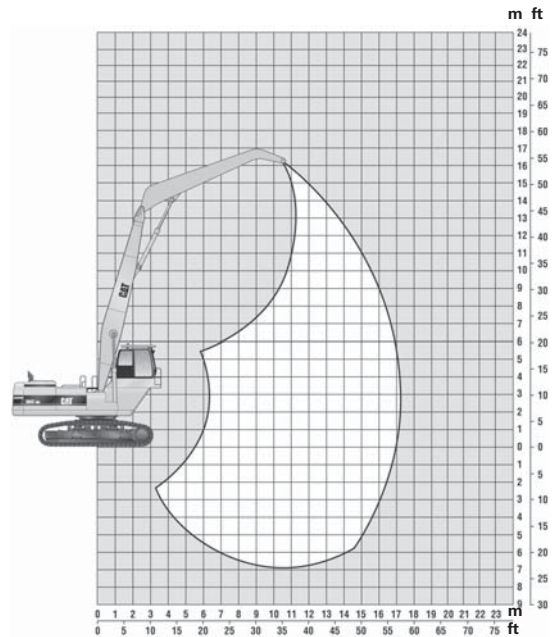

Maximum Reach 17.2 m (56'6")

385C MH Specifications

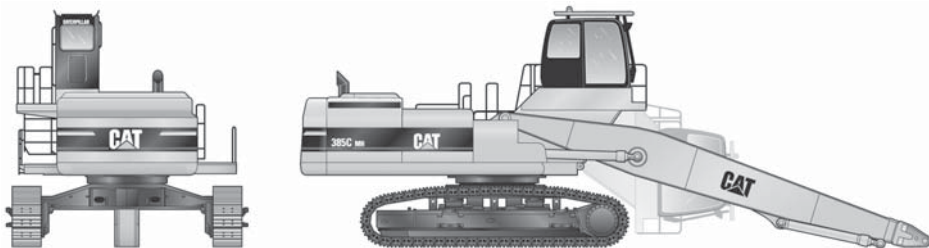

Model	385C MH			
	Long Front		Short Front	
Overall Weight	92.6 t	204,200 lb	92.6 t	204,200 lb
Horsepower (Net)	382 kW	513 hp	382 kW	513 hp
Maximum Horizontal Reach	21.8 m	71'6"	17.2 m	56'6"
Maximum Vertical Pin Height	22.6 m	74'2"	16.3 m	53'3"

Lift Capacities

385C MH — 21.8 m (71.5') Front

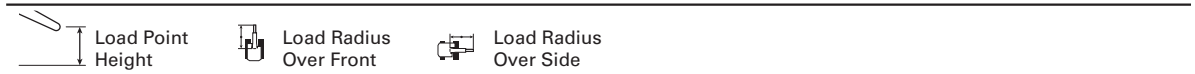

Load Point Height	4.5 m/15.0 ft		6.0 m/20.0 ft		9.0 m/30.0 ft		12.0 m/40.0 ft		13.5 m/45.0 ft		15.0 m/50.0 ft		18.0 m/60.0 ft		19.5 m/65.0 ft		21.0 m/70.0 ft		Load at Maximum Reach							
	kg	lb	kg	lb	kg	lb	kg	lb	kg	lb	kg	lb	kg	lb	kg	lb	kg	lb	kg	lb	m	ft				
21.0 m 70.0 ft							*9980	*9980											*9600	*9600	12.18					
19.5 m 65.0 ft									*10 120	*10 120									*8750	*8750	14.17					
18.0 m 60.0 ft							*25,662	*25,662			*12 060	*12 060	*9860	*9860					*8210	*8210	15.77					
16.5 m 55.0 ft									*13 270	*13 270	*11 730	*11 730							*7830	*7830	17.08					
15.0 m 50.0 ft									*13 230	*13 230	*12 190	*12 190	*8070	*8070					*7580	*7580	18.17					
13.5 m 45.0 ft									*13 280	*13 280	*12 200	*12 200	*10 120	*10 120					*7410	*7410	19.09					
12.0 m 40.0 ft									*13 400	*13 400	*12 270	*12 270	*10 090	*10 090	*8350	*8350			*7300	*7300	19.84					
10.5 m 35.0 ft							*15 010	*15 010	*13 580	*13 580	*12 370	*12 370	10 150	9970	8620	8460			*7250	*7250	20.46					
9.0 m 30.0 ft							*32,584	*32,584	*29,476	*29,476	*26,852	*26,852	21,716	21,319	18,387	18,012			*16,006	*16,006	66.96					
7.5 m 25.0 ft							*15 350	*15 350	*13 800	*13 800	*12 510	*12 510	9970	9780	8520	8350			*7250	*7150	20.95					
6.0 m 20.0 ft							*20 620	*20 620	*15 710	*15 710	*14 030	*14 030	*12 650	*12 650	9740	9560	8370	8200	7200	7040	6970	6820	21.32			
4.5 m 15.0 ft							*44,644	*44,644	*34,061	*34,061	*30,424	*30,424	*27,426	*27,426	20,900	20,503	17,902	17,549			15,410	15,080	69.8			
3.0 m 10.0 ft							*21 490	*21 490	*16 070	*16 070	*14 240	*14 240	*12 770	12 750	9490	9300	8190	8030	7090	6940	6710	6560	21.58			
1.5 m 5.0 ft							*46,495	*46,495	*34,811	*34,811	*30,865	*30,865	*27,668	27,448	20,371	19,974	17,549	17,196	15,146	14,815	14,815	14,484	70.7			
0.0 m 0.0 ft							*22 210	*22 210	*16 350	*16 350	*14 410	*14 410	12 490	12 260	9220	9030	8000	7830	6970	6820	6520	6380	21.73			
-1.5 m -5.0 ft							*48,083	*48,083	*35,406	*35,406	*31,217	*31,217	26,874	26,389	19,798	19,401	17,152	16,799	14,925	14,595	14,396	14,065	71.3			
-3.0 m -10.0 ft							*22 650	*22 650	*16 500	*16 500	14 110	13 850	12 000	11 780	8950	8770	7810	7640	6850	6690	6410	6260	21.78			
-4.5 m -15.0 ft							*49,053	*49,053	*35,737	*35,737	35,671	30,424	29,851	25,838	25,353	19,224	18,827	16,755	16,402	14,683	14,330	14,132	13,801	71.5		
-6.0 m -20.0 ft							*22 650	*22 650	16 030	15 730	13 510	13 250	11 550	11 320	8700	8510	7630	7460	6730	6580	6350	6210	21.72			
-7.5 m -25.0 ft							*49,097	*49,097	34,568	33,907	29,123	28,550	24,890	24,383	18,695	18,298	16,380	16,028	14,440	14,110	13,999	13,691	71.3			
-9.0 m							*22 170	*22 170	15 350	15 040	12 990	12 730	11 150	10 930	8470	8290	7470	7300	6640	6480	6370	6220	21.56			
-10.5 m							*48,083	*48,083	33,091	32,430	27,999	27,426	24,030	23,523	18,232	17,835	16,050	15,697	14,264	13,933	14,043	13,713	70.7			
-12.0 m							*6740	*6740	*20 990	*20 990	14 810	14 510	12 570	12 310	10 600	8290	8100	7350	7180	6570	6420	*6240	*6240	21.29		
-13.5 m							*15,432	*15,432	*45,988	*45,988	31,923	31,262	27,095	26,522	23,325	22,818	17,835	17,439	15,807	15,432		*13,735	*13,735	69.8		
-15.0 m							*7830	*7830	*19 360	*19 360	14 420	14 120	12 250	11 990	10 580	10 350	8160	7970	7270	7100		*5750	*5750	20.91		
-16.5 m							*12,037	*12,037	*17,813	*17,813	*42,858	*42,858	31,085	30,424	26,411	25,838	22,796	22,289	17,571	17,174	*15,410	15,300		*12,632	*12,632	68.5
-18.0 m							*9060	*9060	*17 890	*17 890	*13 750	*13 750	12 050	11 790	10 420	10 190	*7800	*7800	*6310	*6310		*5160	*5160	20.41		
-19.5 m							*20,503	*20,503	*38,735	*38,735	*29,674	*29,674	*25,970	25,419	22,443	21,958	*16,491	*16,491	*12,985	*12,985		*11,310	*11,310	66.9		
-21.0 m							*15 580	*15 580	*12 270	*12 270	*10 770	*10 770	*9370	*9370	*6590	*6590										
-22.5 m							*33,643	*33,643	*26,367	*26,367	*23,082	*23,082	*19,996	*19,996	*13,691	*13,691										
-24.0 m									*10 390	*10 390	*9120	*9120	*7830	*7830												
-25.5 m									*22,179	*22,179	*19,357	*19,357	*16,491	*16,491												

*Rated by hydraulic capacity rather than stability capacity. The use of a work tool attachment point to handle/lift objects, could affect the machine lift performance. Always refer to the appropriate Operation and Maintenance Manual for specific product information.

Lift Capacities

385C MH — 17.2 m (56.5') Front



Load Point Height	4.5 m/15.0 ft		6.0 m/20.0 ft		7.5 m/25.0 ft		9.0 m/30.0 ft		10.5 m/35.0 ft		12.0 m/40.0 ft		13.5 m/45.0 ft		15.0 m/50.0 ft		16.5 m/55.0 ft		Load at Maximum Reach			
	kg	lb	kg	lb	kg	lb	kg	lb	kg	lb	kg	lb	kg	lb	kg	lb	kg	lb	kg	lb	m	ft
15.0 m 50.0 ft												*13 430	*13 430							*13 020	*13 020	12.32
13.5 m 45.0 ft												*14 520	*14 520	*12 830	*12 830					*12 620	*12 620	13.64
12.0 m 40.0 ft												*15 450	*15 450	*14 150	*14 150					*12 430	*12 430	14.68
10.5 m 35.0 ft												*16 470	*16 470	*15 350	*15 350	*13 350	*13 350			*12 400	*12 400	15.5
9.0 m 30.0 ft												*18 040	*18 040	*16 870	*16 870	*15 570	*15 570	14 290	14 060	*12 510	*12 390	16.15
7.5 m 25.0 ft												*19 190	*19 190	*17 370	*17 370	*15 860	*15 860	14 100	13 870	*11 870	*11 670	16.63
6.0 m 20.0 ft												*42,439	*42,439	*41,689	*41,689	*37,743	*37,743	*34,480	*34,480	30,314	29,829	54.4
4.5 m 15.0 ft												*21 860	*21 860	*22 850	*22 850	*20 050	*20 050	*17 910	*16 120	13 860	13 640	16.96
3.0 m 10.0 ft												*47,642	*47,642	*49,516	*49,516	*43,497	*43,497	*38,890	*35,164	34,701	29,829	55.6
1.5 m 5.0 ft												*28 870	*28 870	*24 190	*24 190	*20 900	*20 900	*18 440	*18 440	16 000	15 740	17.15
0.0 m 0.0 ft												*62,457	*62,457	*52,404	*52,404	*45,327	*45,327	*40,014	*40,014	34,458	33,907	56.3
-1.5 m -5.0 ft												*30 670	*30 670	*25 310	*25 310	*21 600	*21 600	18 590	18 290	15 610	15 350	17.22
-3.0 m -10.0 ft												*66,381	*66,381	*54,829	*54,829	*46,826	*46,826	40,080	39,419	33,643	33,069	56.5
-4.5 m -15.0 ft												*31 670	*31 670	*25 990	*25 990	21 920	21 570	18 080	17 780	15 250	14 990	17.14
-6.0 m -20.0 ft												*68,608	*68,608	*56,306	*56,306	47,267	46,495	38,978	38,316	32,871	32,298	56.3
												*7550	*7550	*21 560	*21 560	*26 070	*26 070	21 310	20 960	17 340	14 940	16.94
												*17,835	*17,835	*52,051	*52,051	*56,504	56,328	45,944	45,173	38,030	37,390	55.6
												*3750	*3750	*8380	*8380	*18 230	*25 460	20 850	20 500	17 300	17 000	16.59
												*8,686	*8,686	*19,445	*19,445	*42,924	*55,182	55,005	44,952	44,181	37,302	54.4
												*5810	*5810	*9930	*9930	*18 130	*24 130	20 190	17 070	16 770	14 520	16.1
												*13,294	*13,294	*22,818	*22,818	*42,219	*52,228	44,291	43,519	36,795	36,156	54.4
												*11 830	*11 830	*19 400	*19 400	*22 040	*22 040	*18 880	*18 880	*16 190	*13 790	15.44
												*27,051	*27,051	*44,930	*44,930	*47,598	*47,598	40,697	40,697	34,789	34,789	50.5
												*21 590	*21 590	*19 120	*19 120	*16 470	*16 470	*14 040	*14 040	*11 670	*11 670	
												*47,443	*47,443	*41,094	*41,094	*35,296	*35,296	*29,917	*29,917	*24,604	*24,604	

*Rated by hydraulic capacity rather than stability capacity. The use of a work tool attachment point to handle/lift objects, could affect the machine lift performance. Always refer to the appropriate Operation and Maintenance Manual for specific product information.

MAGNET SELECTION GUIDE

Cat MH Model	Gen. Required (kW)	Recommended Magnet Size (Diameter)					
		1219 mm (48")	1448 mm (57")	1676 mm (66")	1829 mm (72")	1981 mm (78")	2210 mm (87")
M322D2 MH	11.0 m (36'1") Front	X	X				
M324D2 MH	12.5 m (40'11") Front		X				
M325D MH	15.6 m (51'4") Front		X				
M325D MH	14.3 m (47'0") Front		X				
M325D LMH	15.6 m (51'4") Front		X				
M325D LMH	14.3 m (47'0") Front			X			
MH3022	11.0 m (36'1") Front	X	X				
MH3024	12.5 m (40'11") Front		X				
MH3037	14.4 m (47'4") Front		X	X			
MH3037	15.8 m (52'0") Front	X	X				
MH3049	17.8 m (58'5") Front			X			
MH3059	19.3 m (63'5") Front			X	X		
385C MH	21.8 m (71'6") Front				X		
385C MH	17.2 m (56'6") Front						X

GRAPPLE SELECTION GUIDE

Cat MH Model	Gen. Required (kW)	Recommended Orange Peel Grapple Size — m ³ /(yd ³)								
		0.60 (0.75)	0.76 (1.00)	0.95 (1.25)	1.14 (1.50)	1.5 (2.00)	1.0 (2.50)	2.3 (3.00)	3.0 (4.00)	3.8 (5.00)
M322D2 MH	11.0 m (36'1") Front	X								
M324D2 MH	12.5 m (40'11") Front		X							
M325D MH	15.6 m (51'4") Front	X								
M325D MH	14.3 m (47'0") Front		X							
M325D LMH	15.6 m (51'4") Front		X							
M325D LMH	14.3 m (47'0") Front			X						
MH3022	11.0 m (36'1") Front	X								
MH3024	12.5 m (40'11") Front		X							
MH3037	14.4 m (47'4") Front		X	X						
MH3037	15.8 m (52'0") Front		X	X						
MH3049	17.8 m (58'5") Front		X	X	X					
MH3059	19.3 m (63'5") Front				X	X	X			
385C MH	21.8 m (71'6") Front							X		
385C MH	17.2 m (56'6") Front									X

Grapple size must be matched to the machine size, linkage configuration and considering material density. For material density in the 1200 kg/m³ (2000 lb/yd³) range the grapple in the table above can be used. For different material densities, please contact your Cat dealer for other grapple options.

INSTITUTE OF SCRAP RECYCLING INDUSTRIES INC.

Scrap Specifications Guidelines for Ferrous Scrap

ISRI

Code Definition

- 200 **No. 1 heavy melting steel.** Wrought iron and/or steel scrap 6.35 mm ($\frac{1}{4}$ in) and over in thickness. Individual pieces not over 1524 × 610 mm (60 × 24 in) (charging box size) prepared in a manner to insure compact charging.
- 203 **No. 2 heavy melting steel.** Wrought iron and steel scrap, black and galvanized, 3.18 mm ($\frac{1}{8}$ in) and over in thickness, charging box size to include material not suitable as No. 1 heavy melting steel. Prepared in a manner to insure compact charging.
- 207 **No. 1 busheling.** Clean steel scrap, not exceeding 305 mm (12 in) in any dimensions, including new factory busheling (for example, sheet clippings, stampings, etc.). May not include old auto body and fender stock. Free of metal coated, limed, vitreous enameled, and electrical sheet containing over 0.5 percent silicon.
- 208 **No. 1 bundles.** New black steel sheet scrap, clippings or skeleton scrap, compressed or hand bundled, to charging box size, and weighing not less than 34 kg (75 lb) per cubic foot. (Hand bundles are tightly secured for handling with a magnet.) May include Stanley balls or mandrel wound bundles or skeleton reels, tightly secured. May include chemically detinned material. May not include old auto body or fender stock. Free of metal coated, limed, vitreous enameled, and electrical sheet containing over 0.5 percent silicon.
- 209 **No. 2 bundles.** Old black and galvanized steel sheet scrap, hydraulically compressed to charging box size and weighing not less than 34 kg (75 lb) per cubic foot. May not include tin or lead-coated material of vitreous enameled material.
- 210 **Shredded Scrap.** Homogeneous iron and steel scrap magnetically separated, originating from automobiles, unprepared No. 1 and No. 2 steel, miscellaneous baling and sheet scrap. Average density 23 kg (50 lb) per cubic foot.
- 211 **Shredded Scrap.** Homogeneous iron and steel scrap magnetically separated, originating from automobiles, unprepared No. 1 and No. 2 steel, miscellaneous baling and sheet scrap. Average density 34 kg (70 lb) per cubic foot.
- 219 **Machine shop turnings.** Clean steel or wrought iron turnings, free of iron borings, nonferrous metals in a free state, scale, or excessive oil. May not include badly rusted or corroded stock.
- 231 **Plate and structural steel, 1.5 m (5 ft) and under.** Cut structural and plate scrap, 1.5 m (5 ft) and under. Clean open hearth steel plates, structural shapes, crop ends, shearings, or broken steel tires. Dimensions not less than 6.35 mm ($\frac{1}{4}$ in) thickness, not over 1.5 m (5 ft) in length and 457 mm (18 in) in width. Phosphorous or sulphur not over 0.05 percent.
- 234 **Punchings and plate scrap.** Punchings or stampings, plate scrap, and bar crops containing not over 0.05 percent phosphorous or sulphur and not over 0.5 percent silicon, free from alloys. All materials cut 305 mm (12 in) and under, and with the exception of punchings or stampings, at least 3.18 mm ($\frac{1}{8}$ in) in thickness. Punchings or stampings under 152 mm (6 in) in diameter may be any gauge.

MINING & OFF-HIGHWAY TRUCKS

CONTENTS

Features	10-2
Truck Specifications	10-4
Tire Specifications	10-19
Use of Brake Performance Curves	10-20
Fixed Times for Hauling Units	10-20
Mechanical Power Train Efficiencies	10-21

Curves:

770G Tier 4 Final Rimpull-Speed-Gradeability, Brake Performance	10-22
770G Rimpull-Speed-Gradeability, Brake Performance	10-25
772G Tier 4 Final Rimpull-Speed-Gradeability, Brake Performance	10-28
772G Rimpull-Speed-Gradeability, Brake Performance	10-31
773E Rimpull-Speed-Gradeability, Brake Performance	10-34
773G Tier 4 Final Rimpull-Speed-Gradeability, Brake Performance	10-37
773G Rimpull-Speed-Gradeability, Brake Performance	10-40
775G Tier 4 Final Rimpull-Speed-Gradeability, Brake Performance	10-43
775G Rimpull-Speed-Gradeability, Brake Performance	10-46
777D Rimpull-Speed-Gradeability, Brake Performance	10-49
777G Tier 4 Final Rimpull-Speed-Gradeability, Brake Performance	10-52
777G Rimpull-Speed-Gradeability, Brake Performance	10-55
785C Rimpull-Speed-Gradeability, Brake Performance	10-58
785D Rimpull-Speed-Gradeability, Brake Performance	10-61
789D Rimpull-Speed-Gradeability, Brake Performance	10-64
793D Rimpull-Speed-Gradeability, Brake Performance	10-68
793F Rimpull-Speed-Gradeability, Brake Performance	10-73
MT5300D AC Rimpull-Speed-Gradeability, Brake Performance	10-78
795F Rimpull-Speed-Gradeability, Brake Performance	10-80
797F Rimpull-Speed-Gradeability, Brake Performance	10-82

Features:

- **Cat® Four-Stroke Diesel Engines** — Turbocharged, after-cooled, adjustment-free fuel system (direct injection).
 - **Electronically-Controlled Automatic Transmission** — Speed sensing device automatically shifts transmission between 1st and gear selected by operator.
 - **Truck Production Management System (TPMS)** — Utilizes strut pressure sensors and an on-board micro-processor to determine payload weight, cycle segment times, delay times, actual clock time and date of each cycle.
 - **VIMSTM** — Monitors all vital machine functions. Keeps operator informed of current machine operating conditions, helps reduce downtime and allows service personnel easy access to data for fast accurate diagnosis. VIMS includes the Truck Production Management System.
 - **Mechanical Electronic Unit Injection (MEUITM)** in the 770 through 793D — Electronically maintains fuel settings, provides automatic altitude and air filter restriction compensation, and features automatic variable timing, improved diagnostics and increased fuel efficiency.
 - **Common Rail Fuel System** — in the C175 engines are used on (793F, 795F AC, and 797F) trucks.
 - **Oil Cooled Disc Brakes** — Provide retarding, service, parking, and secondary braking in a single sealed, fade-resistant, maintenance-free unit. Standard on the 770 through 775G and 777D, front brakes are caliper disc and can be switched out of the service system when not needed but activate as part of the secondary system. Standard on the 777G through 797F, front brakes are oil-cooled disc, providing excellent control in slippery conditions.
 - **Automatic Retarder Control (ARC)** — Electronically controls braking on grade to maintain optimal engine RPM and oil cooling. ARC benefits include engine overspeed protection, ease of operation, faster downhill speeds, smoother ride and better control in slippery conditions.
 - **Traction Control System (TCS)** — Electronically monitors and controls rear wheel slippage for greater traction and enhanced truck performance in poor underfoot conditions. If slippage exceeds a set limit, the oil-cooled disc brakes engage to slow the spinning wheel. Torque is then automatically transferred to the wheel with better traction. Available on the 770 through 797F.
 - **Full Hydraulic Steering** — Functions with front suspension cylinders serving as kingpins.
 - **Suspension Cylinders** — Four independent, self-contained, nitrogen/oil-pneumatic suspension cylinders absorb loading and road shocks. Wide spacing for stability.
 - **Truck Bodies** — A variety of truck bodies are available to meet your application specific requirements. Those options include MSDII (mine specific design), X, flat floor, dual slope and gateless coal bodies. The Caterpillar body program ensures the truck is configured for an optimal haulage solution.
 - **Integral Roll Over Protective Structure (ROPS)** — Integral Four-Post ROPS cab standard on all models. Resiliently mounted to the main frame to reduce vibration and sound, the integral ROPS structure is designed as an extension of the truck frame. The ROPS/FOPS structure provides “five sided protection” for the operator and trainer.
 - **Separate Hydraulic Systems** — Prevent cross contamination.
 - **Safety** — Caterpillar continues to be proactive in developing construction and mining trucks that meet or exceed industry standards. Safety is an integral part of the machine design.
- An example of enhanced safety through the development of products, processes and solutions includes Cat Integrated Object Detection System which is an integrated camera and radar technology. More information on Object Detection is available in the technology section.

NOTE: Not all features are available on all models at this time.

Sustainability:

A variety of features improve sustainability in areas of decreasing waste, extending component life and lowering emissions levels. The 777G, 785D and 797F trucks offer Oil Renewal systems. The 777G, 785D, 793F, 797F trucks offer Continuous Rear Axle Filtration, Extended Life Filters and Extended maintenance intervals which aid in decreasing the amount of waste contributed to our environment.

- **Engines with advanced technology** contribute less emissions to the environment while maintaining fuel efficiency.
- **Advanced Surface Technology (AST)** is a replacement for hard chrome coatings on some steel parts, including Suspension and hoist Cylinder Rods.
- **Other features on 793F, 797F Mining trucks** include rear axle oil savers, front wheel sight glass, two piece cover on the final drive, ecology drains and brake wear indicators all of which help to maximize component life.

NOTE: Not all features are available on all models at this time.

Non-Dumper Offerings:

For certain applications the Caterpillar OEM Solution Group offers non-dumper arrangements for the 770G, 772G, 773G, 775G, 777G and 785D.

Non-dumper arrangements include a water truck and tractor configuration. For updates on additional offerings please contact Caterpillar OEM Solutions Group.

NOTE: Listed features may be standard on some models. Optional on others. Contact your Cat dealer for specific information.

MT Family of Mining Truck Offerings:

The Cat MT Family of trucks provide an AC drive solution that meets the needs of many miners for a straightforward truck that balances productivity and operating cost. The proven MT family of trucks are now available as the D Series with Cat engines, AC drive systems and VIMS, all developed and supported by Caterpillar.

- **Performance** — The Cat power and electric drive industry leading dynamic retarding capacity combine with wet disc brakes and blended service braking, when stopping, deliver operator confidence and performance.
- **Reliable AC Electric Drive System** — The Cat AC electric drive power train is 100% Caterpillar designed, integrated and supported.
- **Focus on Safety** — ROPS cab, wide access stairways, industry leading dynamic retarding, wet disc brakes traction control, and quiet radial retarder grid with wide right side visibility.
- **Simply Serviceable** — Simple hydraulic systems, modular components, hydraulic gauge cabinet, grouped service locations, engine bay service walkways and more ground accessible maintenance points translate into less downtime.
- **Maneuverability, Ride and Tire Life** — Beam axle suspension carries road stress, separating it from the frame and reducing frame-shock loads.
- **Frame Durability** — Straight-rail, box-section frame design eliminates sources of stress concentration such as bends and breaks. Deep-section main rails in critical frame areas reduce stress and increase frame fatigue life. Continuous frame rail beams with deep section in critical area and ROPS supports provide rugged, dependable service.
- **Comfortable Cab** — Spacious and quiet ROPS Mega cab offers excellent visibility with intuitive, easy to learn controls.

MODEL	770G		770G		770G	
Body Type	Flat Floor		Quarry Body		Dual Slope	
Emission Standards	Tier 4 Final****		Tier 4 Final****		Tier 4 Final****	
Gross Machine Weight	71 214 kg	157,000 lb	71 214 kg	157,000 lb	71 214 kg	157,000 lb
Chassis Weight*	25 466 kg	56,144 lb	25 466 kg	56,144 lb	25 466 kg	56,144 lb
Body Weight	7953 kg	17,533 lb	10 095 kg	22,256 lb	7758 kg	17,103 lb
Payload Without Liner	37 795 kg	83,323 lb	35 652 kg	78,600 lb	37 990 kg	83,753 lb
Standard Liner Weight	2943 kg	6488 lb	—		2810 kg	6195 lb
Target Payload**	34 852 kg	76,835 lb	—		35 180 kg	77,558 lb
Capacity:						
Struck (SAE)	17.2 m ³	22.52 yd³	17.2 m ³	22.52 yd³	18 m ³	23.5 yd³
Heaped (2:1) (SAE)	25.1 m ³	32.8 yd³	25.1 m ³	32.8 yd³	25.9 m ³	33.9 yd³
Distribution Empty:						
Front		51%		51%		51%
Rear		49%		49%		49%
Distribution Loaded:						
Front		34%		34%		34%
Rear		66%		66%		66%
Engine Model	C15 ACERT™		C15 ACERT		C15 ACERT	
Number of Cylinders	6		6		6	
Bore	137 mm	5.4"	137 mm	5.4"	137 mm	5.4"
Stroke	171 mm	6.7"	171 mm	6.7"	171 mm	6.7"
Displacement	15 L	928 in³	15 L	928 in³	15 L	928 in³
Net Power	356 kW	477 hp	356 kW	477 hp	356 kW	477 hp
Gross Power	384 kW	515 hp	384 kW	515 hp	384 kW	515 hp
Standard Tires	18.00R33 (E4)		18.00R33 (E4)		18.00R33 (E4)	
Machine Clearance Turning Circle	20.30 m	66'6"	20.30 m	66'6"	20.30 m	66'6"
Fuel Tank Refill Capacity	529 L	140 U.S. gal	529 L	140 U.S. gal	529 L	140 U.S. gal
Diesel Exhaust Fluid Refill Capacity	21 L	6 U.S. gal	21 L	6 U.S. gal	21 L	6 U.S. gal
Top Speed (Loaded)	73.5 km/h	45.7 mph	73.5 km/h	45.7 mph	73.5 km/h	45.7 mph
GENERAL DIMENSIONS (Empty):						
Height to Canopy Rock Guard Rail	4.21 m	13'10"	4.21 m	13'10"	4.21 m	13'10"
Wheelbase	3.96 m	13'0"	3.96 m	13'0"	3.96 m	13'0"
Overall Length (Operating)	8.80 m	28'10"	8.80 m	28'10"	8.80 m	28'10"
Overall Length (Shipping)	8.80 m	28'10"	8.80 m	28'10"	8.80 m	28'10"
Loading Height (Empty)	3.23 m	10'7"	3.23 m	10'7"	3.23 m	10'7"
Height at Full Dump	8.28 m	27'2"	8.28 m	27'2"	8.28 m	27'2"
Body Length (Target Length)	5.64 m	18'6"	5.64 m	18'6"	5.65 m	18'6"
Width (Operating)	4.78 m	15'8"	4.78 m	15'8"	4.78 m	15'8"
Width (Shipping)***	3.95 m	13'0"	3.95 m	13'0"	3.95 m	13'0"
Front Tire Tread	3.11 m	10'3"	3.11 m	10'3"	3.11 m	10'3"

*Weights include lubricants, coolants and 100% fuel.

**Refer to Caterpillar's 10/10/20 Payload Policy for Off-Highway Trucks.

***Disassembled.

****Meets U.S. EPA Tier 4 Final, EU Stage IV, and Japan 2014 (Tier 4 Final) emission standards.

MODEL	770G		770G		770G	
Body Type	Flat Floor		Quarry Body		Dual Slope	
Emission Standards	Tier 3 Equivalent and Tier 2 Equivalent****		Tier 3 Equivalent and Tier 2 Equivalent****		Tier 3 Equivalent and Tier 2 Equivalent****	
Gross Machine Weight	71 214 kg	157,000 lb	71 214 kg	157,000 lb	71 214 kg	157,000 lb
Chassis Weight*	24 900 kg	54,895 lb	24 900 kg	54,895 lb	24 900 kg	54,895 lb
Body Weight	7850 kg	17,306 lb	10 095 kg	22,255 lb	7665 kg	16,898 lb
Payload Without Liner	38 464 kg	84,799 lb	36 219 kg	79,850 lb	38 649 kg	85,207 lb
Standard Liner Weight	2940 kg	6482 lb	—		2895 kg	6382 lb
Target Payload**	35 524 kg	78,318 lb	—		35 754 kg	78,825 lb
Capacity:						
Struck (SAE)	17.6 m ³	23.0 yd³	17.5 m ³	22.9 yd³	17.6 m ³	23.0 yd³
Heaped (2:1) (SAE)	25.2 m ³	33.0 yd³	24.9 m ³	32.5 yd³	25.2 m ³	32.9 yd³
Distribution Empty:						
Front		51%		51%		51%
Rear		49%		49%		49%
Distribution Loaded:						
Front		34%		34%		34%
Rear		66%		66%		66%
Engine Model	C15 ACERT		C15 ACERT		C15 ACERT	
Number of Cylinders	6		6		6	
Bore	137 mm	5.4"	137 mm	5.4"	137 mm	5.4"
Stroke	171 mm	6.7"	171 mm	6.7"	171 mm	6.7"
Displacement	15 L	928 in³	15 L	928 in³	15 L	928 in³
Net Power	360 kW	483 hp	360 kW	483 hp	360 kW	483 hp
Gross Power	381 kW	511 hp	381 kW	511 hp	381 kW	511 hp
Standard Tires	18.00R33 (E4)		18.00R33 (E4)		18.00R33 (E4)	
Machine Clearance Turning Circle	20.30 m	66'6"	20.30 m	66'6"	20.30 m	66'6"
Fuel Tank Refill Capacity	529 L	140 U.S. gal	529 L	140 U.S. gal	529 L	140 U.S. gal
Top Speed (Loaded)	73.5 km/h	45.7 mph	73.5 km/h	45.7 mph	73.5 km/h	45.7 mph
GENERAL DIMENSIONS (Empty):						
Height to Canopy Rock Guard Rail	4.21 m	13'10"	4.21 m	13'10"	4.21 m	13'10"
Wheelbase	3.96 m	13'0"	3.96 m	13'0"	3.96 m	13'0"
Overall Length (Operating)	8.80 m	28'10"	8.80 m	28'10"	8.80 m	28'10"
Overall Length (Shipping)	8.80 m	28'10"	8.80 m	28'10"	8.80 m	28'10"
Loading Height (Empty)	3.23 m	10'7"	3.23 m	10'7"	3.23 m	10'7"
Height at Full Dump	8.28 m	27'2"	8.28 m	27'2"	8.28 m	27'2"
Body Length (Target Length)	5.64 m	18'6"	5.64 m	18'6"	5.65 m	18'6"
Width (Operating)	4.78 m	15'8"	4.78 m	15'8"	4.78 m	15'8"
Width (Shipping)***	3.95 m	13'0"	3.95 m	13'0"	3.95 m	13'0"
Front Tire Tread	3.11 m	10'3"	3.11 m	10'3"	3.11 m	10'3"

*Weights include lubricants, coolants and 100% fuel.

**Refer to Caterpillar's 10/10/20 Payload Policy for Off-Highway Trucks.

***Disassembled.

****Meets Tier 3, Stage IIIA, Japan 2006 (Tier 3) equivalent emission standards and Tier 2, Stage II, Japan 2001 (Tier 2) equivalent emission standards.

MODEL	772G		772G		772G	
Body Type	Flat Floor		Quarry Body		Dual Slope	
Emission Standards	Tier 4 Final****		Tier 4 Final****		Tier 4 Final****	
Gross Machine Weight	82 100 kg	181,000 lb	82 100 kg	181,000 lb	82 100 kg	181,000 lb
Chassis Weight*	26 356 kg	58,105 lb	26 356 kg	58,105 lb	26 356 kg	58,105 lb
Body Weight	8340 kg	18,387 lb	10 555 kg	23,270 lb	8147 kg	17,961 lb
Payload Without Liner	47 404 kg	104,508 lb	45 189 kg	99,625 lb	47 597 kg	104,933 lb
Standard Liner Weight	3235 kg	7132 lb	—		3093 kg	6819 lb
Target Payload**	44 169 kg	97,376 lb	—		44 504 kg	98,114 lb
Capacity:						
Struck (SAE)	23.4 m ³	30.6 yd³	23.4 m ³	30.6 yd³	24.1 m ³	31.5 yd³
Heaped (2:1) (SAE)	31.3 m ³	40.9 yd³	31.3 m ³	40.9 yd³	32 m ³	41.9 yd³
Distribution Empty:						
Front		51%		51%		51%
Rear		49%		49%		49%
Distribution Loaded:						
Front		34%		34%		34%
Rear		66%		66%		66%
Engine Model	C18 ACERT		C18 ACERT		C18 ACERT	
Number of Cylinders	6		6		6	
Bore	145 mm	5.7"	145 mm	5.7"	145 mm	5.7"
Stroke	183 mm	7.2"	183 mm	7.2"	183 mm	7.2"
Displacement	18 L	1105 in³	18 L	1105 in³	18 L	1105 in³
Net Power	410 kW	550 hp	410 kW	550 hp	410 kW	550 hp
Gross Power	451 kW	605 hp	451 kW	605 hp	451 kW	605 hp
Standard Tires	21.00R33 (E4)		21.00R33 (E4)		21.00R33 (E4)	
Machine Clearance Turning Circle	21.6 m	70'10"	21.6 m	70'10"	21.6 m	70'10"
Fuel Tank Refill Capacity	529 L	140 U.S. gal	529 L	140 U.S. gal	529 L	140 U.S. gal
Diesel Exhaust Fluid Refill Capacity	21 L	6 U.S. gal	21 L	6 U.S. gal	21 L	6 U.S. gal
Top Speed (Loaded)	79.7 km/h	49.5 mph	79.7 km/h	49.5 mph	79.7 km/h	49.5 mph
GENERAL DIMENSIONS (Empty):						
Height to Canopy Rock Guard Rail	4.21 m	13'10"	4.21 m	13'10"	4.21 m	13'10"
Wheelbase	3.96 m	13'0"	3.96 m	13'0"	3.96 m	13'0"
Overall Length (Operating)	8.80 m	28'10"	8.80 m	28'10"	8.80 m	28'10"
Overall Length (Shipping)	8.80 m	28'10"	8.80 m	28'10"	8.80 m	28'10"
Loading Height (Empty)	3.64 m	11'11"	3.64 m	11'11"	3.64 m	11'11"
Height at Full Dump	8.28 m	27'2"	8.28 m	27'2"	8.28 m	27'2"
Body Length (Target Length)	5.78 m	19'0"	5.78 m	19'0"	5.79 m	19'0"
Width (Operating)	4.78 m	15'8"	4.78 m	15'8"	4.78 m	15'8"
Width (Shipping)***	3.95 m	13'0"	3.95 m	13'0"	3.95 m	13'0"
Front Tire Tread	3.11 m	10'3"	3.11 m	10'3"	3.11 m	10'3"

*Weights include lubricants, coolants and 100% fuel.

**Refer to Caterpillar's 10/10/20 Payload Policy for Off-Highway Trucks.

***Disassembled.

****Meets Tier 4 Final, Stage IV, and Japan 2014 (Tier 4 Final) emission standards.

MODEL	772G		772G		772G	
Body Type	Flat Floor		Quarry Body		Dual Slope	
Emission Standards	Tier 3 Equivalent and Tier 2 Equivalent****		Tier 3 Equivalent and Tier 2 Equivalent****		Tier 3 Equivalent and Tier 2 Equivalent****	
Gross Machine Weight	82 100 kg	181,000 lb	82 100 kg	181,000 lb	82 100 kg	181,000 lb
Chassis Weight*	26 863 kg	59,222 lb	26 863 kg	59,222 lb	26 863 kg	59,222 lb
Body Weight	8215 kg	18,111 lb	10 555 kg	23,270 lb	8030 kg	17,703 lb
Payload Without Liner	47 022 kg	103,667 lb	44 682 kg	98,508 lb	47 207 kg	104,075 lb
Standard Liner Weight	3235 kg	7132 lb	—		2995 kg	6603 lb
Target Payload**	43 787 kg	96,535 lb	—		44 212 kg	97,472 lb
Capacity:						
Struck (SAE)	24.0 m ³	31.4 yd³	23.7 m ³	31.1 yd³	23.9 m ³	31.3 yd³
Heaped (2:1) (SAE)	31.3 m ³	41.0 yd³	31.1 m ³	40.6 yd³	31.2 m ³	40.8 yd³
Distribution Empty:						
Front		51%		51%		51%
Rear		49%		49%		49%
Distribution Loaded:						
Front		34%		34%		34%
Rear		66%		66%		66%
Engine Model	C18 ACERT		C18 ACERT		C18 ACERT	
Number of Cylinders	6		6		6	
Bore	145 mm	5.7"	145 mm	5.7"	145 mm	5.7"
Stroke	183 mm	7.2"	183 mm	7.2"	183 mm	7.2"
Displacement	18 L	1105 in³	18 L	1105 in³	18 L	1105 in³
Net Power	415 kW	556 hp	415 kW	556 hp	415 kW	556 hp
Gross Power	446 kW	598 hp	446 kW	598 hp	446 kW	598 hp
Standard Tires	21.00R33 (E4)		21.00R33 (E4)		21.00R33 (E4)	
Machine Clearance Turning Circle	21.6 m	70'10"	21.6 m	70'10"	21.6 m	70'10"
Fuel Tank Refill Capacity	529 L	140 U.S. gal	529 L	140 U.S. gal	529 L	140 U.S. gal
Top Speed (Loaded)	79.7 km/h	49.5 mph	79.7 km/h	49.5 mph	79.7 km/h	49.5 mph
GENERAL DIMENSIONS (Empty):						
Height to Canopy Rock Guard Rail	4.21 m	13'10"	4.21 m	13'10"	4.21 m	13'10"
Wheelbase	3.96 m	13'0"	3.96 m	13'0"	3.96 m	13'0"
Overall Length (Operating)	8.80 m	28'10"	8.80 m	28'10"	8.80 m	28'10"
Overall Length (Shipping)	8.80 m	28'10"	8.80 m	28'10"	8.80 m	28'10"
Loading Height (Empty)	3.64 m	11'11"	3.64 m	11'11"	3.64 m	11'11"
Height at Full Dump	8.28 m	27'2"	8.28 m	27'2"	8.28 m	27'2"
Body Length (Target Length)	5.78 m	19'0"	5.78 m	19'0"	5.79 m	19'0"
Width (Operating)	4.78 m	15'8"	4.78 m	15'8"	4.78 m	15'8"
Width (Shipping)***	3.95 m	13'0"	3.95 m	13'0"	3.95 m	13'0"
Front Tire Tread	3.11 m	10'3"	3.11 m	10'3"	3.11 m	10'3"

*Weights include lubricants, coolants and 100% fuel.

**Refer to Caterpillar's 10/10/20 Payload Policy for Off-Highway Trucks.

***Disassembled.

****Meets Tier 3, Stage IIIA, Japan 2006 (Tier 3) equivalent emission standards and Tier 2, Stage II, Japan 2001 (Tier 2) equivalent emission standards.

MODEL	773E****		773G*****	
Body Type	Medium Impact Steel Dual Slope		Flat Floor Steel Lined	
Emission Standards	Tier 2/Stage II equivalent		Tier 4 Final	
Gross Machine Weight	99 300 kg	219,000 lb	102 739 kg	226,500 lb
Chassis Weight*	30 730 kg	67,748 lb	35 191 kg	77,582 lb
Body Weight	9210 kg	20,305 lb	11 423 kg	25,184 lb
Payload Without Liner	59 360 kg	130,866 lb	56 125 kg	123,735 lb
Standard Liner Weight	3900 kg	8600 lb	3794 kg	8363 lb
Target Payload**	55 460 kg	122,268 lb	52 332 kg	115,372 lb
Capacity:				
Struck (SAE)	26.6 m ³	34.8 yd³	25.8 m ³	33.7 yd³
Heaped (2:1) (SAE)	35.2 m ³	46 yd³	35.0 m ³	45.8 yd³
Distribution Empty:				
Front		47.3%		50%
Rear		52.7%		50%
Distribution Loaded:				
Front		33.3%		35%
Rear		66.7%		65%
Engine Model	3412E		C27 ACERT	
Number of Cylinders	12		12	
Bore	137 mm	5.4"	137 mm	5.4"
Stroke	152 mm	6"	152 mm	6"
Displacement	27 L	1649 in³	27 L	1649 in³
Net Power	501 kW	671 hp	534 kW	717 hp
Gross Power	530 kW	710 hp	578 kW	775 hp
Standard Tires	24.00R35 (E4)		24.00R35 (E4)	
Machine Clearance Turning Circle	25 m	82'0"	26.5 m	86'11"
Fuel Tank Refill Capacity	700 L	185 U.S. gal	795 L	210 U.S. gal
Top Speed (Loaded)	62.2 km/h	38.6 mph	66.9 km/h	41.6 mph
GENERAL DIMENSIONS (Empty):				
Height to Canopy Rock Guard Rail	4.39 m	14'5"	4.46 m	14'7"
Wheelbase	4.19 m	13'9"	4.22 m	13'10"
Overall Length (Operating)	9.60 m	31'6"	10.15 m	33'4"
Overall Length (Shipping)	9.12 m	29'11"	9.2 m	30'2"
Loading Height (Empty)	3.77 m	12'4"	3.77 m	12'5"
Height at Full Dump	8.79 m	28'10"	9.28 m	30'5"
Body Length (Target Length)	6.40 m	21'0"	6.1 m	20'0"
Width (Operating)	5.07 m	16'8"	5.67 m	18'7"
Width (Shipping)***	3.99 m	13'1"	3.99 m	13'11"
Front Tire Tread	3.28 m	10'9"	3.21 m	10'6"

*Weights include lubricants, coolants and 100% fuel.

**Refer to Caterpillar's 10/10/20 Payload Policy for Off-Highway Trucks.

***Disassembled.

****India sourced, not available in all regions.

*****Gateless Coal Bodies are available through OEM Solutions.

MODEL	773G****		773G****		773G****	
Body Type	Dual Slope Steel Lined		Flat Floor Steel Lined		Dual Slope Steel Lined	
Emission Standards	Tier 4 Final		Tier 2 equivalent		Tier 2 equivalent	
Gross Machine Weight	102 739 kg	226,500 lb	102 739 kg	226,500 lb	102 739 kg	226,500 lb
Chassis Weight*	35 191 kg	77,582 lb	34 536 kg	76,139 lb	34 536 kg	76,139 lb
Body Weight	11 049 kg	24,358 lb	11 423 kg	25,184 lb	11 049 kg	24,358 lb
Payload Without Liner	56 500 kg	124,560 lb	56 780 kg	125,178 lb	57 154 kg	126,003 lb
Standard Liner Weight	3728 kg	8218 lb	3794 kg	8363 lb	3728 kg	8218 lb
Target Payload**	52 772 kg	116,342 lb	52 986 kg	116,815 lb	53 426 kg	117,785 lb
Capacity:						
Struck (SAE)	26.4 m ³	34.5 yd³	25.8 m ³	33.7 yd³	26.4 m ³	34.5 yd³
Heaped (2:1) (SAE)	35.2 m ³	46.0 yd³	35.0 m ³	45.8 yd³	35.2 m ³	46.0 yd³
Distribution Empty:						
Front		50%		49%		50%
Rear		50%		51%		50%
Distribution Loaded:						
Front		35%		34%		35%
Rear		65%		66%		65%
Engine Model	C27 ACERT		C27 ACERT		C27 ACERT	
Number of Cylinders	12		12		12	
Bore	137 mm	5.4"	137 mm	5.4"	137 mm	5.4"
Stroke	152 mm	6"	152 mm	6"	152 mm	6"
Displacement	27 L	1649 in³	27 L	1649 in³	27 L	1649 in³
Net Power	534 kW	717 hp	546 kW	733 hp	546 kW	733 hp
Gross Power	578 kW	775 hp	578 kW	775 hp	578 kW	775 hp
Standard Tires	24.00R35 (E4)		24.00R35 (E4)		24.00R35 (E4)	
Machine Clearance Turning Circle	26.5 m	86'11"	26.5 m	86'11"	26.5 m	86'11"
Fuel Tank Refill Capacity	795 L	210 U.S. gal	795 L	210 U.S. gal	795 L	210 U.S. gal
Top Speed (Loaded)	66.9 km/h	41.6 mph	67.6 km/h	42.0 mph	67.6 km/h	42.0 mph
GENERAL DIMENSIONS (Empty):						
Height to Canopy Rock Guard Rail	4.46 m	14'7"	4.46 m	14'7"	4.46 m	14'7"
Wheelbase	4.22 m	13'10"	4.22 m	13'10"	4.22 m	13'10"
Overall Length (Operating)	10.07 m	33'1"	10.15 m	33'4"	10.07 m	33'1"
Overall Length (Shipping)	9.2 m	30'2"	9.2 m	30'2"	9.2 m	30'2"
Loading Height (Empty)	3.77 m	12'5"	3.77 m	12'5"	3.77 m	12'5"
Height at Full Dump	9.28 m	30'5"	9.28 m	30'5"	9.28 m	30'5"
Body Length (Target Length)	6.1 m	20'0"	6.1 m	20'0"	6.1 m	20'0"
Width (Operating)	5.67 m	18'7"	5.67 m	18'7"	5.67 m	18'7"
Width (Shipping)***	3.99 m	13'11"	3.99 m	13'11"	3.99 m	13'11"
Front Tire Tread	3.21 m	10'6"	3.21 m	10'6"	3.21 m	10'6"

*Weights include lubricants, coolants and 100% fuel.

**Refer to Caterpillar's 10/10/20 Payload Policy for Off-Highway Trucks.

***Disassembled.

****Gateless Coal Bodies are available through OEM Solutions.

MODEL	775G****		775G****		775G****	
Body Type	Flat Floor Steel Lined		Quarry Body		Dual Slope Steel Lined	
Emission Standards	Tier 4 Final		Tier 4 Final		Tier 4 Final	
Gross Machine Weight	111 811 kg	246,500 lb	111 811 kg	246,500 lb	111 811 kg	246,500 lb
Chassis Weight*	35 281 kg	77,781 lb	35 281 kg	77,781 lb	35 281 kg	77,781 lb
Body Weight	11 760 kg	25,925 lb	13 827 kg	30,483 lb	11 466 kg	25,277 lb
Payload Without Liner	64 770 kg	142,794 lb	62 703 kg	138,236 lb	65 064 kg	143,442 lb
Standard Liner Weight	4124 kg	9094 lb	—	—	4015 kg	8854 lb
Target Payload**	60 646 kg	133,700 lb	—	—	61 048 kg	134,588 lb
Capacity:						
Struck (SAE)	31.7 m ³	41.5 yd³	32.0 m ³	41.9 yd³	32.1 m ³	42.0 yd³
Heaped (2:1) (SAE)	41.6 m ³	54.4 yd³	41.9 m ³	54.8 yd³	41.7 m ³	54.5 yd³
Distribution Empty:						
Front		49%		51%		49%
Rear		51%		49%		51%
Distribution Loaded:						
Front		34%		34%		34%
Rear		66%		66%		66%
Engine Model	C27 ACERT		C27 ACERT		C27 ACERT	
Number of Cylinders	12		12		12	
Bore	137 mm	5.4"	137 mm	5.4"	137 mm	5.4"
Stroke	152 mm	6"	152 mm	6"	152 mm	6"
Displacement	27 L	1649 in³	27 L	1649 in³	27 L	1649 in³
Net Power	572 kW	767 hp	572 kW	767 hp	572 kW	767 hp
Gross Power	615 kW	825 hp	615 kW	825 hp	615 kW	825 hp
Standard Tires	24.00R35 (E4)		24.00R35 (E4)		24.00R35 (E4)	
Machine Clearance Turning Circle	26.5 m	86'11"	26.5 m	86'11"	26.5 m	86'11"
Fuel Tank Refill Capacity	795 L	210 U.S. gal	795 L	210 U.S. gal	795 L	210 U.S. gal
Top Speed (Loaded)	66.9 km/h	41.6 mph	66.9 km/h	41.6 mph	66.9 km/h	41.6 mph
GENERAL DIMENSIONS (Empty):						
Height to Canopy Rock Guard Rail	4.46 m	14'7"	4.46 m	14'7"	4.46 m	14'7"
Wheelbase	4.22 m	13'10"	4.22 m	13'10"	4.22 m	13'10"
Overall Length (Operating)	10.15 m	33'4"	10.15 m	33'4"	10.07 m	33'1"
Overall Length (Shipping)	9.21 m	30'3"	9.21 m	30'3"	9.21 m	30'3"
Loading Height (Empty)	3.97 m	13'0"	3.97 m	13'0"	3.97 m	13'0"
Height at Full Dump	9.28 m	30'5"	9.28 m	30'5"	9.28 m	30'5"
Body Length (Target Length)	6.1 m	20'0"	6.1 m	20'0"	6.1 m	20'0"
Width (Operating)	5.67 m	18'7"	5.67 m	18'7"	5.67 m	18'7"
Width (Shipping)***	3.97 m	13'0"	3.97 m	13'0"	3.97 m	13'0"
Front Tire Tread	3.21 m	10'6"	3.21 m	10'6"	3.21 m	10'6"

*Weights include lubricants, coolants and 100% fuel.

**Refer to Caterpillar's 10/10/20 Payload Policy for Off-Highway Trucks.

***Disassembled.

****Gateless Coal Bodies are available through OEM Solutions.

MODEL	775G****		775G****		775G****	
Body Type	Flat Floor Steel Lined		Quarry Body		Dual Slope Steel Lined	
Emission Standards	Tier 2 equivalent		Tier 2 equivalent		Tier 2 equivalent	
Gross Machine Weight	111 811 kg	246,500 lb	111 811 kg	246,500 lb	111 811 kg	246,500 lb
Chassis Weight*	34 622 kg	76,327 lb	34 622 kg	76,327 lb	34 622 kg	76,327 lb
Body Weight	11 760 kg	25,925 lb	13 827 kg	30,483 lb	11 466 kg	25,277 lb
Payload Without Liner	65 430 kg	144,248 lb	63 362 kg	139,690 lb	65 724 kg	144,896 lb
Standard Liner Weight	4124 kg	9094 lb	—		4015 kg	8854 lb
Target Payload**	61 305 kg	135,154 lb	—		61,708 kg	136,042 lb
Capacity:						
Struck (SAE)	31.7 m ³	41.5 yd³	32.0 m ³	41.9 yd³	32.1 m ³	42.0 yd³
Heaped (2:1) (SAE)	41.6 m ³	54.4 yd³	41.9 m ³	54.8 yd³	41.7 m ³	54.5 yd³
Distribution Empty:						
Front		49%		51%		49%
Rear		51%		49%		51%
Distribution Loaded:						
Front		34%		34%		34%
Rear		66%		66%		66%
Engine Model	C27 ACERT		C27 ACERT		C27 ACERT	
Number of Cylinders	12		12		12	
Bore	137 mm	5.4"	137 mm	5.4"	137 mm	5.4"
Stroke	152 mm	6"	152 mm	6"	152 mm	6"
Displacement	27 L	1649 in³	27 L	1649 in³	27 L	1649 in³
Net Power	584 kW	783 hp	584 kW	783 hp	584 kW	783 hp
Gross Power	615 kW	825 hp	615 kW	825 hp	615 kW	825 hp
Standard Tires	24.00R35 (E4)		24.00R35 (E4)		24.00R35 (E4)	
Machine Clearance Turning Circle	26.5 m	86'11"	26.5 m	86'11"	26.5 m	86'11"
Fuel Tank Refill Capacity	795 L	210 U.S. gal	795 L	210 U.S. gal	795 L	210 U.S. gal
Top Speed (Loaded)	67.6 km/h	42.0 mph	67.6 km/h	42.0 mph	67.6 km/h	42.0 mph
GENERAL DIMENSIONS (Empty):						
Height to Canopy Rock Guard Rail	4.46 m	14'7"	4.46 m	14'7"	4.46 m	14'7"
Wheelbase	4.22 m	13'10"	4.22 m	13'10"	4.22 m	13'10"
Overall Length (Operating)	10.15 m	33'4"	10.15 m	33'4"	10.07 m	33'1"
Overall Length (Shipping)	9.21 m	30'3"	9.21 m	30'3"	9.21 m	30'3"
Loading Height (Empty)	3.97 m	13'0"	3.97 m	13'0"	3.97 m	13'0"
Height at Full Dump	9.28 m	30'5"	9.28 m	30'5"	9.28 m	30'5"
Body Length (Target Length)	6.1 m	20'0"	6.1 m	20'0"	6.1 m	20'0"
Width (Operating)	5.67 m	18'7"	5.67 m	18'7"	5.67 m	18'7"
Width (Shipping)***	3.97 m	13'0"	3.97 m	13'0"	3.97 m	13'0"
Front Tire Tread	3.21 m	10'6"	3.21 m	10'6"	3.21 m	10'6"

*Weights include lubricants, coolants and 100% fuel.

**Refer to Caterpillar's 10/10/20 Payload Policy for Off-Highway Trucks.

***Disassembled.

****Gateless Coal Bodies are available through OEM Solutions.

MODEL	777D		777G****		777G****	
Body Type	Dual Slope		Dual Slope		X-Body	
Emission Standards	Tier 1 equivalent		Tier 4 Final		Tier 4 Final	
Gross Machine Weight	163 360 kg	360,143 lb	164 654 kg	363,000 lb	164 654 kg	363,000 lb
Chassis Weight*	50 610 kg	111,575 lb	52 241 kg	115,171 lb	52 241 kg	115,171 lb
Body Weight	16 687 kg	36,788 lb	16 075 kg	35,429 lb	15 878 kg	35,005 lb
Payload without Liner	95 996 kg	212,055 lb	96 338 kg	212,389 lb	96 535 kg	212,823 lb
Standard Liner Weight	5460 kg	12,040 lb	5695 kg	12,555 lb	4686 kg	10,331 lb
Target Payload**	90 536 kg	199,597 lb	90 643 kg	199,833	91 849 kg	202,492 lb
Capacity:						
Struck (SAE)	42 m ³	54.6 yd³	42 m ³	54.6 yd³	42 m ³	54.6 yd³
Heaped (2:1) (SAE)	60.2 m ³	78.6 yd³	60.2 m ³	78.6 yd³	60.2 m ³	78.6 yd³
Distribution Empty:						
Front		47%		41.8%		41.8%
Rear		53%		58.2%		58.2%
Distribution Loaded:						
Front		33%		33%		33%
Rear		67%		67%		67%
Engine Model	3508B EUI		C32 ACERT		C32 ACERT	
Number of Cylinders	8		12		12	
Bore	170 mm	6.7"	145 mm	5.7"	145 mm	5.7"
Stroke	190 mm	7.5"	162 mm	6.4"	162 mm	6.4"
Displacement	34.5 L	2105 in³	32.1 L	1959 in³	32.1 L	1959 in³
Net Power	699 kW	938 hp	683 kW	916 hp	683 kW	916 hp
Gross Power	746 kW	1000 hp	765 kW	1025 hp	765 kW	1025 hp
Standard Tires	27.00R49		27.00R49		27.00R49	
Machine Clearance Turning Circle	28.4 m	83'0"	28.4 m	83'0"	28.4 m	83'0"
Fuel Tank Refill Capacity	1137 L	300 U.S. gal	1137 L	300 U.S. gal	1137 L	300 U.S. gal
Top Speed (Loaded)	60.4 km/h	39.9 mph	67.0 km/h	41.7 mph	67.0 km/h	41.7 mph
GENERAL DIMENSIONS (Empty):						
Height to Canopy Rock Guard Rail	5.17 m	17'0"	4.91 m	16'1"	5.17 m	17'0"
Wheelbase	4.6 m	15'0"	4.6 m	15'0"	4.6 m	15'0"
Overall Length (Operating)	10.3 m	33'8"	10.3 m	33'8"	10.54 m	34'7"
Overall Length (Shipping)	9.78 m	32'1"	9.78 m	32'1"	9.78 m	32'1"
Loading Height (Empty)	4.39 m	14'5"	4.39 m	14'5"	4.38 m	14'4"
Height at Full Dump	10.05 m	33'0"	10.05 m	33'0"	10.33 m	33'11"
Body Length (Target Length)	7.28 m	23'11"	7.28 m	23'11"	7.28 m	23'11"
Width (Operating)	6.1 m	20'0"	6.1 m	20'0"	6.55 m	21'6"
Width (Shipping)***	3.51 m	11'5"	3.51 m	11'5"	3.51 m	11'5"
Front Tire Tread	4.17 m	13'8"	4.17 m	13'8"	4.17 m	13'8"

*Weights include lubricants, coolants and 100% fuel.

**Refer to Caterpillar's 10/10/20 Payload Policy for Off-Highway Trucks.

***Disassembled.

****Gateless Coal Bodies are available through OEM Solutions.

MODEL	777G****		777G****	
Body Type	Dual Slope		X-Body	
Emission Standards	Tier 2 equivalent		Tier 2 equivalent	
Gross Machine Weight	164 654 kg	363,000 lb	164 654 kg	363,000 lb
Chassis Weight*	51 848 kg	114,305 lb	51 848 kg	114,305 lb
Body Weight	16 075 kg	35,439 lb	15 878 kg	35,005 lb
Payload without Liner	96 731 kg	213,256 lb	96 928 kg	213,690 lb
Standard Liner Weight	5695 kg	12,555 lb	4686 kg	10,331 lb
Target Payload**	91 036 kg	200,711 lb	92 242 kg	203,359 lb
Capacity:				
Struck (SAE)	42 m ³	54.6 yd³	42 m ³	54.6 yd³
Heaped (2:1) (SAE)	60.2 m ³	78.6 yd³	60.2 m ³	78.6 yd³
Distribution Empty:				
Front		41.8%		41.8%
Rear		58.2%		58.2%
Distribution Loaded:				
Front		33%		33%
Rear		67%		67%
Engine Model	C32 ACERT		C32 ACERT	
Number of Cylinders	12		12	
Bore	145 mm	5.7"	145 mm	5.7"
Stroke	162 mm	6.4"	162 mm	6.4"
Displacement	32.1 L	1959 in³	32.1 L	1959 in³
Net Power	704 kW	945 hp	704 kW	945 hp
Gross Power	765 kW	1025 hp	765 kW	1025 hp
Standard Tires	27.00R49		27.00R49	
Machine Clearance Turning Circle	28.4 m	83'0"	28.4 m	83'0"
Fuel Tank Refill Capacity	1137 L	300 U.S. gal	1137 L	300 U.S. gal
Top Speed (Loaded)	67.0 km/h	41.7 mph	67.0 km/h	41.7 mph
GENERAL DIMENSIONS (Empty):				
Height to Canopy Rock Guard Rail	4.91 m	16'1"	5.17 m	17'0"
Wheelbase	4.6 m	15'0"	4.6 m	15'0"
Overall Length (Operating)	10.3 m	33'8"	10.54 m	34'7"
Overall Length (Shipping)	9.78 m	32'1"	9.78 m	32'1"
Loading Height (Empty)	4.39 m	14'5"	4.38 m	14'4"
Height at Full Dump	10.05 m	33'0"	10.33 m	33'11"
Body Length (Target Length)	7.28 m	23'11"	7.28 m	23'11"
Width (Operating)	6.1 m	20'0"	6.55 m	21'6"
Width (Shipping)***	3.51 m	11'5"	3.51 m	11'5"
Front Tire Tread	4.17 m	13'8"	4.17 m	13'8"

*Weights include lubricants, coolants and 100% fuel.

**Refer to Caterpillar's 10/10/20 Payload Policy for Off-Highway Trucks.

***Disassembled.

****Gateless Coal Bodies are available through OEM Solutions.

MODEL	785C		785D		789D	
Body Type	Dual Slope		Dual Slope		Dual Slope	
Target Gross Machine Weight ‡	249 476 kg	550,000 lb	249 476 kg	550,000 lb	324 319 kg	715,000 lb
Basic Machine Weight*	59 385 kg	130,922 lb	46 240 kg	101,942 lb	48 554 kg	107,043 lb
Attachments**	21 602 kg	47,624 lb	35 781 kg	78,885 lb	52 249 kg	115,190 lb
Body Weight without Liners***	22 997 kg	50,700 lb	22 997 kg	50,700 lb	26 606 kg	58,656 lb
Full Liner	8113 kg	17,886 lb	8113 kg	17,886 lb	9692 kg	21,367 lb
Operating Machine Weight	112 097 kg	247,132 lb	113 131 kg	249,412 lb	137 101 kg	302,256 lb
Debris (3% of Operating Machine Weight)	3363 kg	7414 lb	3394 kg	7482 lb	4113 kg	9068 lb
Empty Operating Weight	115 460 kg	254,546 lb	116 525 kg	256,894 lb	141 214 kg	311,324 lb
Target Payload ‡	134.0 m tons	147.7 tons	133.0 m tons	146.6 tons	183.1 m tons	201.8 tons
Capacity:						
Heaped (2:1) (SAE) Base Body	78 m³	102 yd³	78 m³	102 yd³	108 m³	141 yd³
Heaped (2:1) (SAE) with Std. Sideboards	91 m³	119 yd³	91 m³	119 yd³	125 m³	161 yd³
Distribution Empty:						
Front		45%		45.5%		46%
Rear		55%		54.5%		54%
Distribution Loaded:						
Front		33.3%		33.3%		33%
Rear		66.7%		66.7%		66%
Engine Model	3512B EUI		3512C HD-EUI		3516C HD	
Number of Cylinders	12		12		16	
Bore	170 mm	6.7"	170 mm	6.7"	170 mm	6.7 in
Stroke	190 mm	7.5"	215 mm	8.46"	210 mm	8.3 in
Displacement	51.8 L	3158 in³	58.56 L	3574 in³	78.1 L	4766 in³
Net Power	979 kW	1313 hp	979 kW	1313 hp	1468 kW	1969 hp
Gross Power	1082 kW	1450 hp	1082 kW	1450 hp	1566 kW	2100 hp
Standard Tires	33.00R51		33.00R51		37.00R57	
Machine ClearanceTurning Circle	30.6 m	100'5"	33.2 m	108'11"	30.23 m	99'2"
Fuel Tank Refill Capacity	1893 L	500 U.S. gal	1893 L	500 U.S. gal	2082 L	550 U.S. gal
Top Speed (Loaded)	56.5 km/h	35.1 mph	56.5 km/h	35.1 mph	57.2 km/h	35.5 mph
GENERAL DIMENSIONS (Empty):						
Height to Canopy Rock Guard Rail	5.77 m	19'0"	5.68 m	18'7"	6.50 m	21'4"
Wheelbase	5.18 m	17'0"	5.18 m	17'0"	5.70 m	18'8"
Overall Length (Base Body)	11.02 m	36'3"	11.55 m	37'9"	12.72 m	41'9"
Loading Height (Base Body)	4.97 m	16'4"	4.97 m	16'4"	5.60 m	18'4"
Height at Full Dump	11.21 m	36'10"	11.81 m	38'9"	13.20 m	43'4"
Body Length (Target Length)	7.65 m	25'2"	7.65 m	25'2"	8.29 m	27'3"
Width (Operating)	6.64 m	21'10"	7.06 m	23'2"	7.65 m	25'1"
Width (Shipping)****	3.91 m	12'10"	3.91 m	12'10"	3.84 m	12'7"
Front Tire Tread	4.85 m	15'11"	4.85 m	15'11"	5.37 m	17'8"

*See Weight Definitions and Relations on page 18 of this section. Note: No mandatory or optional attachments or fuel.

**Typical selection of mandatory and optional attachments.

***Data provided is for a representative body and liner package. Several dual slope, flat floor, and mine specific design (MSD) bodies and liner packages are available. All weights, capacities, and dimensions are dependent on the machine configuration (body type, attachments, tires, and optional equipment selected).

****Disassembled.

‡Reference Caterpillar's latest 10/10/20 Payload Policy for information on gross machine operating weight and target payload.

NOTE: Contact Mining Representative to use Caterpillar Weight Configurator for application specific weights.

MODEL	793D Standard		793D XL5S	
Body Type	MSD II		MSD II	
Target Gross Machine Weight §	383 740 kg	846,000 lb	383 740 kg	846,000 lb
Basic Machine Weight*	51 135 kg	112,734 lb	51 310 kg	113,119 lb
Attachments**	65 898 kg	145,281 lb	67 514 kg	148,844 lb
Body Weight without Liners***	26 980 kg	59,481 lb	26 980 kg	59,481 lb
Full Liner	6209 kg	13,688 lb	6209 kg	13,688 lb
Operating Machine Weight	150 223 kg	331,184 lb	152 013 kg	335,132 lb
Debris (3% of Operating Machine Weight)	4507 kg	9936 lb	4560 kg	10,054 lb
Empty Operating Weight	154 729 kg	341,119 lb	156 574 kg	345,186 lb
Target Payload §	229.0 m tons	252.4 tons	227.2 m tons	250.4 tons
Capacity:				
Heaped (2:1) (SAE) Base Body	176 m ³	230 yd³	176 m ³	230 yd³
Distribution Empty:				
Front		46.2%		46%
Rear		53.8%		54%
Distribution Loaded:				
Front		33.3%		33.3%
Rear		66.7%		66.7%
Engine Model	3516B HD EUI		3516B HD EUI	
Number of Cylinders	16		16	
Bore	170 mm	6.7"	170 mm	6.7"
Stroke	215 mm	8.5"	215 mm	8.5"
Displacement	78 L	4760 in²	78 L	4760 in²
Net Power	1694 kW	2273 hp	1694 kW	2273 hp
Gross Power	1801 kW	2415 hp	1801 kW	2415 hp
Standard Tires	40/00R57		40/00R57	
Machine Clearance Turning Circle	33 m	107'0"	33 m	107'0"
Fuel Tank Refill Capacity	4353 L	1150 U.S. gal	4353 L	1150 U.S. gal
Top Speed (Loaded)	59.9 km/h	37.2 mph	59.9 km/h	37.2 mph
GENERAL DIMENSIONS (Empty):				
Height to Canopy Rock Guard Rail	6.6 m	21'8"	6.6 m	21'8"
Wheelbase	5.91 m	19'5"	5.91 m	19'5"
Overall Length (Base Body)	13.01 m	42'9"	13.01 m	42'9"
Loading Height (Base Body)	6.5 m	21'5"	6.5 m	21'5"
Height at Full Dump	13.25 m	43'6"	13.25 m	43'6"
Body Length (Target Length)	8.99 m	29'6"	8.99 m	29'6"
Width (Operating)	8.3 m	27'3"	8.3 m	27'3"
Width (Shipping)****	4.1 m	13'5"	4.1 m	13'5"
Front Tire Tread	5.63 m	18'6"	5.63 m	18'6"

*See Weight Definitions and Relations on page 18 of this section. Note: No mandatory or optional attachments or fuel.

**Typical selection of mandatory and optional attachments.

***Data provided for the 793D Standard (MA1) is for a representative body and liner package. Several dual slope, flat floor, and mine specific design (MSD) bodies and liner packages are available. All weights, capacities, and dimensions are dependent on the machine configuration (body type, attachments, tires, and optional equipment selected).

****Disassembled.

§Reference Caterpillar's latest 10/10/20 Payload Policy for information on gross machine operating weight and target payload.

NOTE: Contact Mining Representative to use Caterpillar Weight Configurator for application specific weights.

MODEL	793F Standard		793F XLP	
	MSD II		MSD II	
Body Type				
Target Gross Machine Weight §	386 008 kg	851,000 lb	390 090 kg	860,000 lb
Basic Machine Weight*	42 638 kg	94,001 lb	42 638 kg	94,001 lb
Attachments**	79 381 kg	175,005 lb	84 594 kg	186,498 lb
Body Weight without Liners***	26 893 kg	59,289 lb	26 893 kg	59,289 lb
Full Liner	6209 kg	13,688 lb	6209 kg	13,688 lb
Operating Machine Weight	155 121 kg	341,983 lb	160 334 kg	353,476 lb
Debris (3% of Operating Machine Weight)	4654 kg	10,259 lb	4810 kg	10,604 lb
Empty Operating Weight	159 775 kg	352,242 lb	165 144 kg	364,080 lb
Target Payload §	226.2 m tons	249.4 tons	224.9 m tons	248.0 tons
Capacity:				
Heaped (2:1) (SAE) Base Body	176 m ³	230 yd³	176 m ³	230 yd³
Distribution Empty:				
Front		47.6%		47.3%
Rear		52.4%		52.7%
Distribution Loaded:				
Front		33.3%		33.3%
Rear		66.7%		66.7%
Engine Model		C175-16		C175-16
Number of Cylinders		16		16
Bore	175 mm	6.9"	175 mm	6.9"
Stroke	220 mm	8.7"	220 mm	8.7"
Displacement	85 L	5187 in³	85 L	5187 in³
Net Power	1848 kW	2478 hp	1848 kW	2478 hp
Gross Power	1976 kW	2650 hp	1976 kW	2650 hp
Standard Tires		40/00R57		46/90R57
Machine Clearance Turning Circle	33 m	107'0"	33 m	107'0"
Fuel Tank Refill Capacity	2839 L	750 U.S. gal	2839 L	750 U.S. gal
Top Speed (Loaded)	60.4 km/h	37.6 mph	60.4 km/h	37.6 mph
GENERAL DIMENSIONS (Empty):				
Height to Canopy Rock Guard Rail	6.6 m	21'8"	6.6 m	21'8"
Wheelbase	5.91 m	19'5"	5.91 m	19'5"
Overall Length (Base Body)	13.7 m	44'11"	13.7 m	44'11"
Loading Height (Base Body)	6.5 m	21'5"	6.5 m	21'5"
Height at Full Dump	13.9 m	45'6"	13.9 m	45'6"
Body Length (Target Length)	8.99 m	29'6"	8.99 m	29'6"
Width (Operating)	8.3 m	27'3"	8.3 m	27'3"
Width (Shipping)****	4.1 m	13'5"	4.1 m	13'5"
Front Tire Tread	5.63 m	18'6"	5.63 m	18'6"

*See Weight Definitions and Relations on page 18 of this section. Note: No mandatory or optional attachments or fuel.

**Typical selection of mandatory and optional attachments.

***Data provided is for a representative body and liner package. Several dual slope, flat floor, and mine specific design (MSD) bodies and liner packages are available. All weights, capacities, and dimensions are dependent on the machine configuration (body type, attachments, tires, and optional equipment selected).

****Disassembled.

§Reference Caterpillar's latest 10/10/20 Payload Policy for information on gross machine operating weight and target payload.

NOTE: Contact Mining Representative to use Caterpillar Weight Configurator for application specific weights.

MODEL	MT5300D AC		795F AC		797F	
Body Type	MT Family Body		MSD II		MSD II	
Target Gross Machine Weight ‡	521 631 kg	1,150,000 lb	570 166 kg	1,257,000 lb	623 690 kg	1,375,000 lb
Basic Machine Weight*	119 975 kg	264,500 lb	118 807 kg	261,924 lb	86 412 kg	190,506 lb
Attachments**	68 048 kg	150,020 lb	79 503 kg	175,273 lb	128 083 kg	282,374 lb
Body Weight without Liners***	27 451 kg	60,520 lb	38 663 kg	85,237 lb	44 275 kg	97,610 lb
Full Liner†	—		7623 kg	16,806 lb	7652 kg	16,870 lb
Operating Machine Weight	215 456 kg	475,000 lb	244 596 kg	539,240 lb	266 422 kg	587,359 lb
Debris (3% of Operating Machine Weight)	—		7338 kg	16,177 lb	7993 kg	17,621 lb
Empty Operating Weight	215 456 kg	475,000 lb	251 933 kg	555,417 lb	274 415 kg	604,980 lb
Target Payload ‡	291 m tons	320 tons	313-317 m tons	345-350 tons	335-363 m tons	370-400 tons
Capacity:						
Heaped (2:1) (SAE) Base Body	180-222 m ³	236-290 yd³	213 m ³	280 yd³	240-267 m ³	315-350 yd³
Distribution Empty:						
Front		49.0%		48%		45.7%
Rear		51.0%		52%		54.3%
Distribution Loaded:						
Front		33.0%		33%		33.3%
Rear		67.0%		67%		66.7%
Engine Model	C175-16		C175-16		C175-20	
Number of Cylinders	16		16			
Bore	175 mm	6.9"	175 mm	6.9"	175 mm	6.9"
Stroke	220 mm	8.7"	220 mm	8.7"	220 mm	8.7"
Displacement	85 L	5187 in³	85 L	5187 in³	106 L	6469 in³
Net Power	—		—		2830 kW	3795 hp
Gross Power	2051-2610 kW	2750-3500 hp	2535 kW	3400 hp	2983 kW	4000 hp
Standard Tires	53/80R63		56/80R63		59/80R63	
Machine Clearance Turning Circle	32.4 m	106'0"	38.7 m	127'0"	42.1 m	138'1"
Fuel Tank Refill Capacity	4922 L	1300 U.S. gal	7192 L	1900 U.S. gal	7571 L	2000 U.S. gal
Top Speed (Loaded)	60 km/h	37 mph	64 km/h	40 mph	67.9 km/h	42.2 mph
GENERAL DIMENSIONS (Empty):						
Height to Canopy Rock Guard Rail	7.59 m	24'11"	7.80 m	25'8"	7.71 m	25'4"
Wheelbase	6.65 m	21'10"	6.73 m	22'1"	7.20 m	23'7"
Overall Length (Base Body)	15.47 m	50'9"	15.15 m	49'9"	15.08 m	48'9"
Loading Height (Base Body)	6.71 m	22'2"	—		7.00 m	23'0"
Loading Height (Empty)	—		7.04 m	23'2"	—	
Height at Full Dump	14.61 m	47'11"	15.06 m	49'6"	15.70 m	51'6"
Body Length (Target Length)	10.21 m	33'6"	15.15 m	49'9"	9.98 m	32'6"
Width (Operating)	9.09 m	29'10"	8.97 m	29'6"	9.76 m	32'0"
Width (Shipping)	2.7 m	8'10"	8.97 m	29'6"	9.76 m	32'0"
Front Tire Tread	7.04 m	23'1"	6.24 m	20'6"	6.53 m	20'5"

*See Weight Definitions and Relations on page 18 of this section. Note: No mandatory or optional attachments or fuel.

**Typical selection of mandatory and optional attachments.

***Data provided is for a representative body and liner package. Several dual slope, flat floor, and mine specific design (MSD) bodies and liner packages are available. All weights, capacities, and dimensions are dependent on the machine configuration (body type, attachments, tires, and optional equipment selected).

‡Reference Caterpillar's latest 10/10/20 Payload Policy for information on gross machine operating weight and target payload.

†Liner used for 797F is a 1/3 solid liner.

NOTE: Contact Mining Representative to use Caterpillar Weight Configurator for application specific weights.

CAT LARGE TRUCK WEIGHT DEFINITIONS

Target Gross Machine Weight	<ul style="list-style-type: none"> - Loaded operating machine weight - Optimum productivity and cost per ton - Used for performance curves and calculations
Basic Machine Weight	Basic chassis weight including shipping fluids, but no attachments, options, body, or tires
Attachments	Combined weight of mandatory attachments and a minimal representation of optional attachments
Body Weight without Liners	Representative weight of body called out in Body Type
Full Liner	Weight of solid steel full liner package for selected Body Type
Standard Sideboard	Weight of appropriate sideboard for selected Body Type and Model
Operating Machine Weight	Basic machine weight plus full fuel, tires, rims, selected attachments, operator, and body
Debris	2%–8% of operating machine weight depending on application
Empty Operating Weight	Operating machine weight plus debris
Target Payload	Target gross machine weight minus empty operating weight

CAT LARGE TRUCK WEIGHT RELATIONS*

Operating Machine Weight	Operating Machine Weight = Basic Machine Weight + Attachments + Body Weight without Liners + Full Liner + Standard Sideboard
Empty Operating Weight	Empty Operating Weight = Operating Machine Weight + Debris
Target Payload	Target Payload = Target Gross Machine Weight – Empty Operating Weight
Target Gross Machine Weight	TGMW
Basic Machine Weight	BMW
Operating Machine Weight	OMW
Empty Operating Weight	EOW
Target Payload	TP

*Reference Caterpillar’s latest 10/10/20 Payload Policy.

MODEL TIRE SIZE	PLY RATING/ STAR RATING*	TYPE	MODEL TIRE SIZE	PLY RATING/ STAR RATING*	TYPE
770, 770G			789D		
18.00R33	★★	E-3	37.00R57	★★	E-4
18.00R33◀	★★	E-4	40.00R57	★★	E-4
772, 772G			793D		
21.00R33◀	★★	E-4	40.00-57	68	E-4
773E			46-90R57	★★	E-4
24.00-35	42	E-4	793F		
24.00R35	★★	E-3	40.00-57	68	E-4
773G			46/90R57	★★	E-4
24.00-35	36	E-4	50/80R57	★★	E-4
24.00-35	42	E-4	795F		
24.00R35	★★	E-3	56/80R63**	★★	E-4
24.00R35◀	★★	E-4	59/80R63***	★★	E-4
775G			797F		
24.00R35◀	★★	E-4	59/80R63	★★	E-4
24.00R35	★★	E-3			
24.00-35	48	E-4			
777D, 777G					
27.00R49	★★	E-3			
27.00R49◀	★★	E-3			
27.00-49	48	E-4			
785C, 785D					
33.00R51	★★	E-3			
33.00R51	★★	E-4			

*Manufacturer uses star (★) rating system instead of ply rating.

**Michelin ONLY.

***Bridgestone and Goodyear ONLY.

◀No charge tire.

USE OF BRAKE PERFORMANCE CURVES

The speed that can be maintained when the machine is descending a grade with retarder applied can be determined from the retarder curves in this section when gross machine weight and total effective grade are known.

Select appropriate grade distance chart that covers total downhill haul; don't break haul into individual segments.

To determine brake performance: Read from gross weight down to the percent effective grade. (Effective grade equals actual % grade *minus* 1% for each 10 kg/metric ton (20 lb/U.S. ton) of rolling resistance.) From this weight-effective grade point, read horizontally to the curve with the highest obtainable speed range, then down to maximum descent speed brakes can safely handle without exceeding cooling capacity. When braking, engine RPM should be maintained at the highest possible level without overspeeding. If cooling oil overheats, reduce ground speed to allow transmission to shift to next lower speed range.

Brake Performance Curves are made in compliance with ISO 10268 and applicable to Sea Level and 32° C (90° F) temperature. Contact Factory for Application Specific Performance.

USE OF RIMPULL-SPEED-GRADEABILITY CURVES

For best results, use Caterpillar Fleet Production and Cost Analysis (FPC) to simulate cycle time, fuel burn, and production for Application Specific Performance inquiries. Contact Factory Representative or visit catminer.cat.com/stb for more information.

(See Wheel Tractor Scraper Section)

Total Effective Grade (or Total Resistance) is grade assistance *minus* rolling resistance.

10 kg/metric ton (20 lb/U.S. ton) = 1% adverse grade.

Example —

With a favorable grade of 20% and rolling resistance of 50 kg/metric ton (100 lb/U.S. ton), find Total Effective Grade.

$$\begin{aligned} (50 \text{ kg/metric ton}) &= 50 \div 10 = 5\% \text{ Effective Grade} \\ &\text{(from Rolling Resistance)} \\ 100 \text{ lb/ton} &= 100 \div 20 = 5\% \text{ Effective Grade} \\ 20\% \text{ (grade)} - 5\% \text{ (resistance)} &= \\ 15\% \text{ Total Effective Grade} \end{aligned}$$

TYPICAL FIXED TIMES FOR HAULING UNITS

Wait time, delays and operator efficiency all impact cycle time. Minimizing truck exchange time can have a significant effect on productivity.

Fixed time for hauling units include:

1. Truck load time (various with loading tool)
2. Truck maneuver in load area (Truck exchange) (Typically 0.6-0.8 min.)
3. Maneuver and dump time at dump point (Typically 1.0-1.2 min.)

Total cycle time is the combination of:

1. The above fixed time
2. Hauling time (Loaded)
3. Return time (Empty)

Example — assume load tool spots hauler with full bucket

	988F	5130B
cycle times	.60	.45
First pass (dump time)	.10 min.	.05 min.
2 passes (full cycle)	.70	.50
3 passes "	1.30	.95
4 passes "	1.90	1.40
5 passes "	2.50	1.85
6 passes "	3.10	2.30
7 passes "	3.70	2.75
8 passes "	4.30	3.20
9 passes "	4.90	3.65
10 passes "	5.40	4.10

NOTE: Other sizes of loading tools will have different cycle times. See Wheel Loader section for **average** cycle times for truck loading.

MECHANICAL POWER TRAIN EFFICIENCIES

In selling against electric drive trucks, power train efficiency is an important consideration. To better illustrate the advantages of mechanical drive performance, grade horsepower, power train efficiency, and retarding horsepower should be compared to electric drive trucks.

Grade horsepower can be calculated by the following formula:

Metric

$$\text{grade HP} = \frac{\text{GMW (kg)} \times \text{TR} \times \text{Speed (km/h)}}{273.75}$$

English

$$= \frac{\text{GMW (lb)} \times \text{TR} \times \text{Speed (mph)}}{375}$$

where TR

(total resistance) = Rolling resistance + Grade resistance
(expressed as a decimal)

English example

700,000 lb GMW, 2% rolling resistance, +8% actual grade at 8.2 mph would require 1530 HP

$$\frac{700,000 \times (.02 + .08) \times 8.2}{375} = 1530 \text{ HP}$$

Metric example

317 520 kg GMW, 2% rolling resistance, +8% actual grade at 13.2 km/h would require 1530 HP

$$\frac{317\,520 \times (.02 + .08) \times 13.2}{273.75} = 1530 \text{ HP}$$

We then calculate power train efficiency by dividing grade horsepower by the gross horsepower produced by the engine. Most electric drive trucks run at constant maximum horsepower while under load. Mechanical drive trucks, however, lug the engine and may produce somewhat less than maximum horsepower. Engine power curves must be utilized to determine exact horsepower produced.

Example

$$\frac{1530 \text{ grade horsepower}}{1800 \text{ gross engine HP}} \times 100 = 85\% \text{ power train efficiency}$$

This exercise illustrates the effect of an efficient mechanical drive power train and should yield results in the 80-85% efficiency range. The same calculation for electric drive trucks would be lower (70-78% range) with a maximum efficiency of about 78% for the most common systems.

Likewise, retarding horsepower being consumed by the retarding system can be calculated by the following formula:

Metric

$$\text{retarding HP} = \frac{\text{GMW (kg)} \times \text{TR} \times \text{Speed (km/h)}}{273.75}$$

English

$$= \frac{\text{GMW (lb)} \times \text{TR} \times \text{Speed (mph)}}{375}$$

where TR

(total resistance) = Rolling resistance + Grade resistance
(expressed as a decimal)

English example

700,000 lb GMW, 2% rolling resistance, -8% actual grade at 14.7 mph would equate to -1646 HP

$$\frac{700,000 \times (.02 - .08) \times 14.7}{375} = 1646 \text{ HP}$$

Metric example

317 520 kg GMW, 2% rolling resistance, -8% actual grade at 23.6 km/h would equate to -1646 HP

$$\frac{317\,520 \times (.02 - .08) \times 23.6}{273.75} = 1646 \text{ HP}$$

This formula is intended for use in determining horsepower being consumed in the field based on field measurements. It is not intended to indicate how fast trucks should be operated on grade. Only job conditions, proper operating procedure, and good judgement should determine safe operating speeds during retarder use.

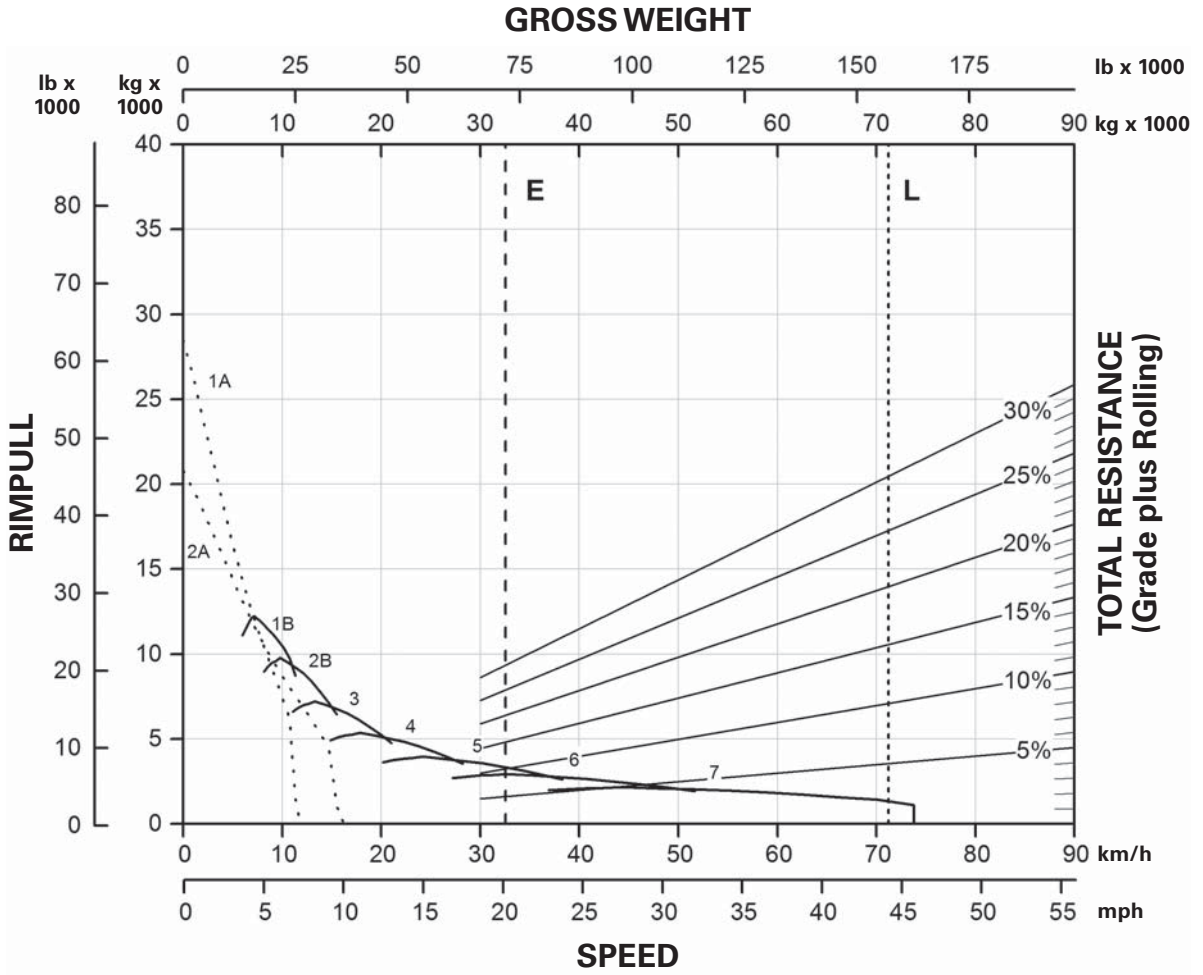

KEY

- 1A – 1st Gear (Torque Converter)
- 1B – 1st Gear
- 2 – 2nd Gear
- 3 – 3rd Gear
- 4 – 4th Gear
- 5 – 5th Gear
- 6 – 6th Gear
- 7 – 7th Gear

KEY

- E – Empty 33 224 kg (73,247 lb)
- L – Target GMW 71 214 kg (157,000 lb)

*Meets Tier 4 Final, Stage IV, and Japan 2014 (Tier 4 Final) emission standards.

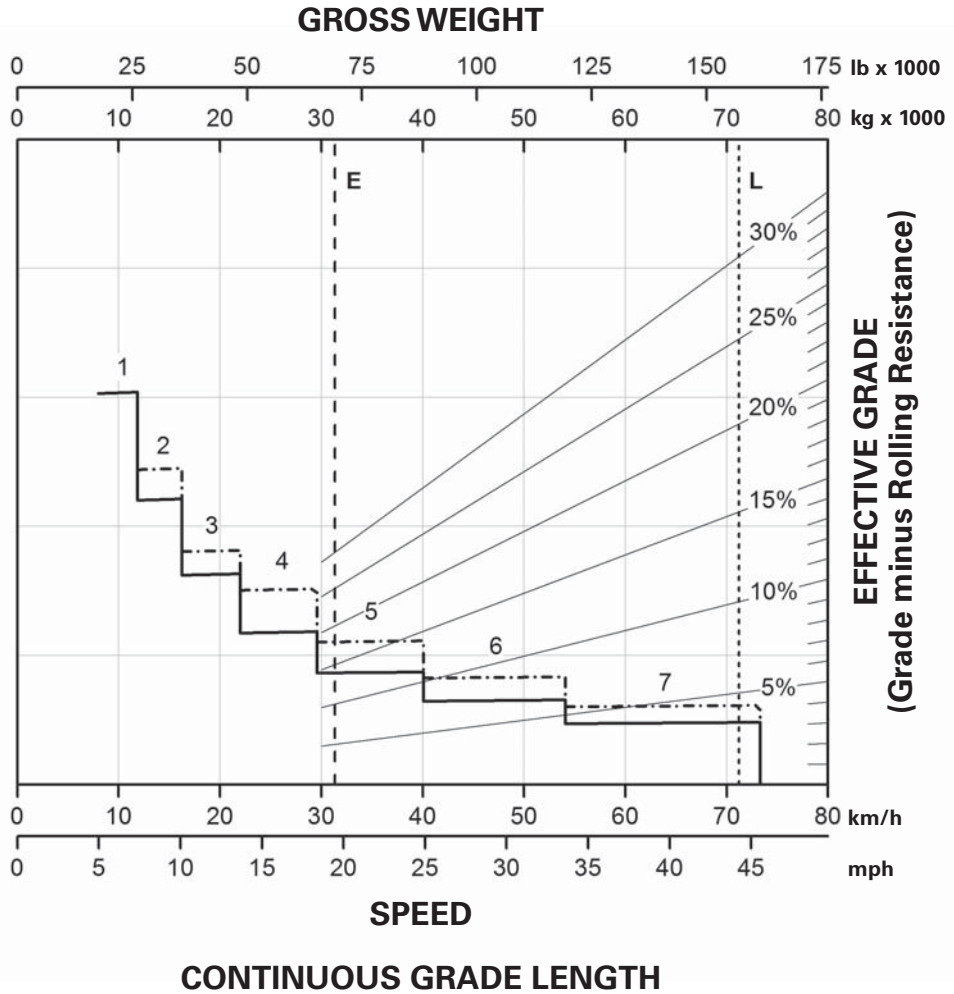

KEY

- 1 — 1st Gear
- 2 — 2nd Gear
- 3 — 3rd Gear
- 4 — 4th Gear
- 5 — 5th Gear
- 6 — 6th Gear
- 7 — 7th Gear

KEY

- E — Empty 33 224 kg (73,247 lb)
- L — Target GMW 71 214 kg (157,000 lb)
- With ARC Only
- - - - - ARC and Engine Brake

*Meets Tier 4 Final, Stage IV, and Japan 2014 (Tier 4 Final) emission standards.

Mining & Off-Highway Trucks

770G Tier 4 Final* Brake Performance

- 450 m (1500 ft) ● 600 m (2000 ft)
- 900 m (3000 ft) ● 1500 m (5000 ft)

GROSS WEIGHT

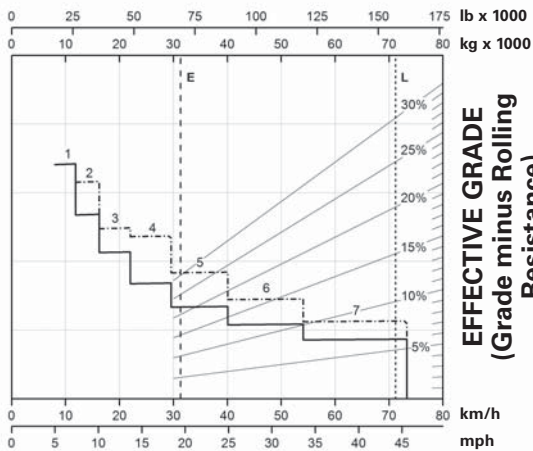

SPEED
GRADE DISTANCE — 450 m (1500 ft)

GROSS WEIGHT

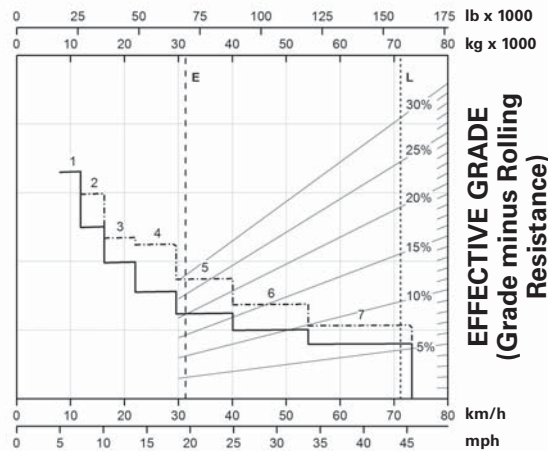

SPEED
GRADE DISTANCE — 600 m (2000 ft)

GROSS WEIGHT

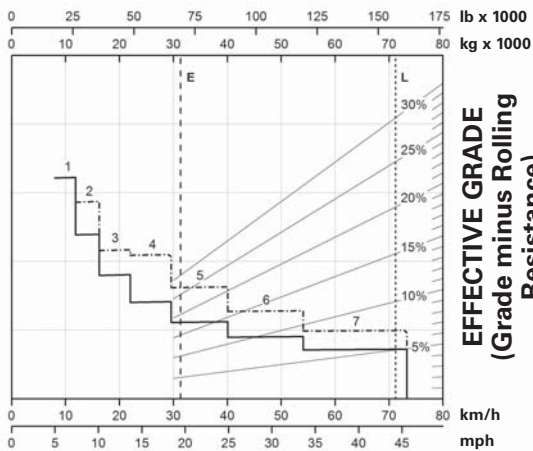

SPEED
GRADE DISTANCE — 900 m (3000 ft)

GROSS WEIGHT

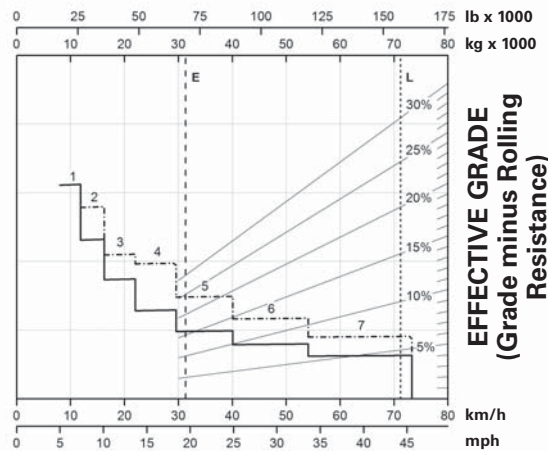

SPEED
GRADE DISTANCE — 1500 m (5000 ft)

KEY

- 1 — 1st Gear
- 2 — 2nd Gear
- 3 — 3rd Gear
- 4 — 4th Gear
- 5 — 5th Gear
- 6 — 6th Gear
- 7 — 7th Gear

KEY

- E — Empty 33 224 kg (73,247 lb)
- L — Target GMW 71 214 kg (157,000 lb)
- With ARC Only
- - - - - ARC and Engine Brake

*Meets Tier 4 Final, Stage IV, and Japan 2014 (Tier 4 Final) emission standards.

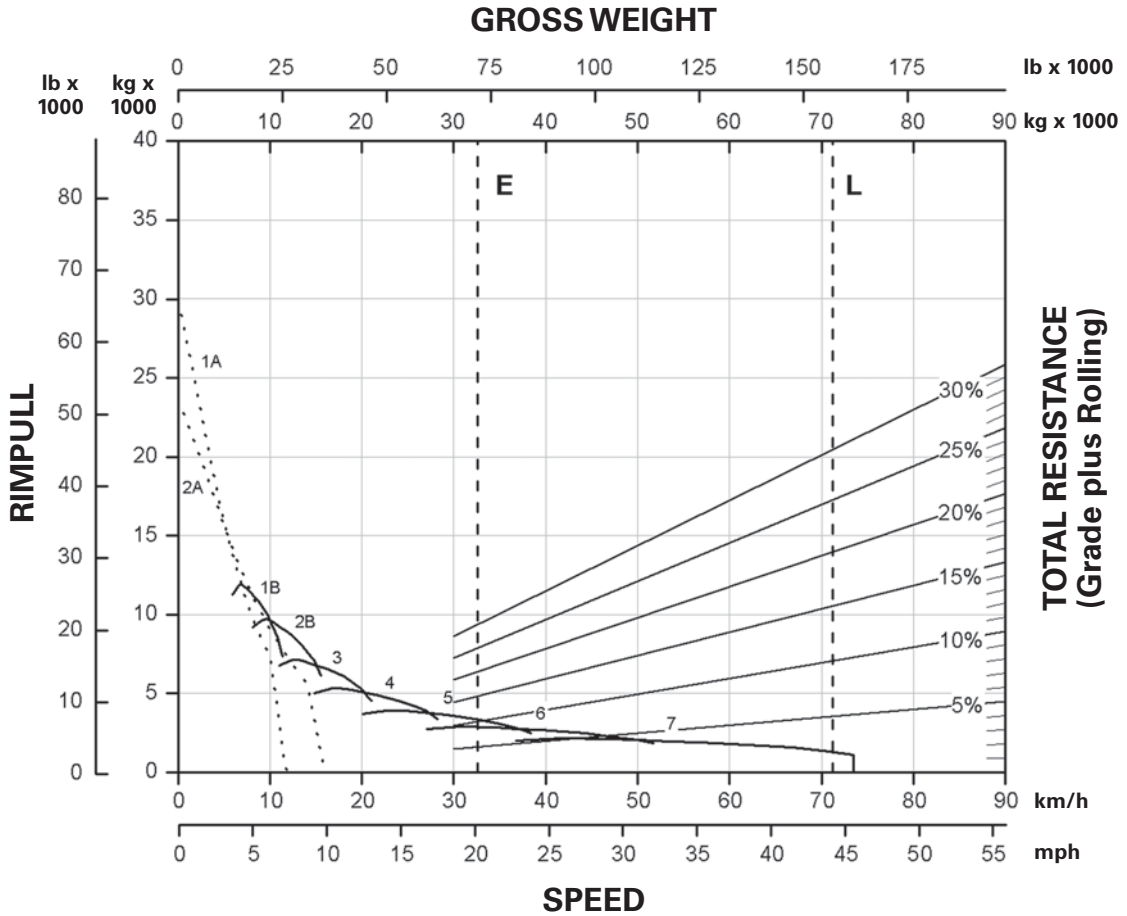

KEY

- 1A – 1st Gear (Torque Converter)
- 1B – 1st gear
- 2A – 2nd Gear (Torque Converter)
- 2B – 2nd Gear
- 3 – 3rd Gear
- 4 – 4th Gear
- 5 – 5th Gear
- 6 – 6th Gear
- 7 – 7th Gear

KEY

- E – Empty Weight 32 565 kg (71,793 lb)
- L – Target GMW 71 214 kg (157,000 lb)

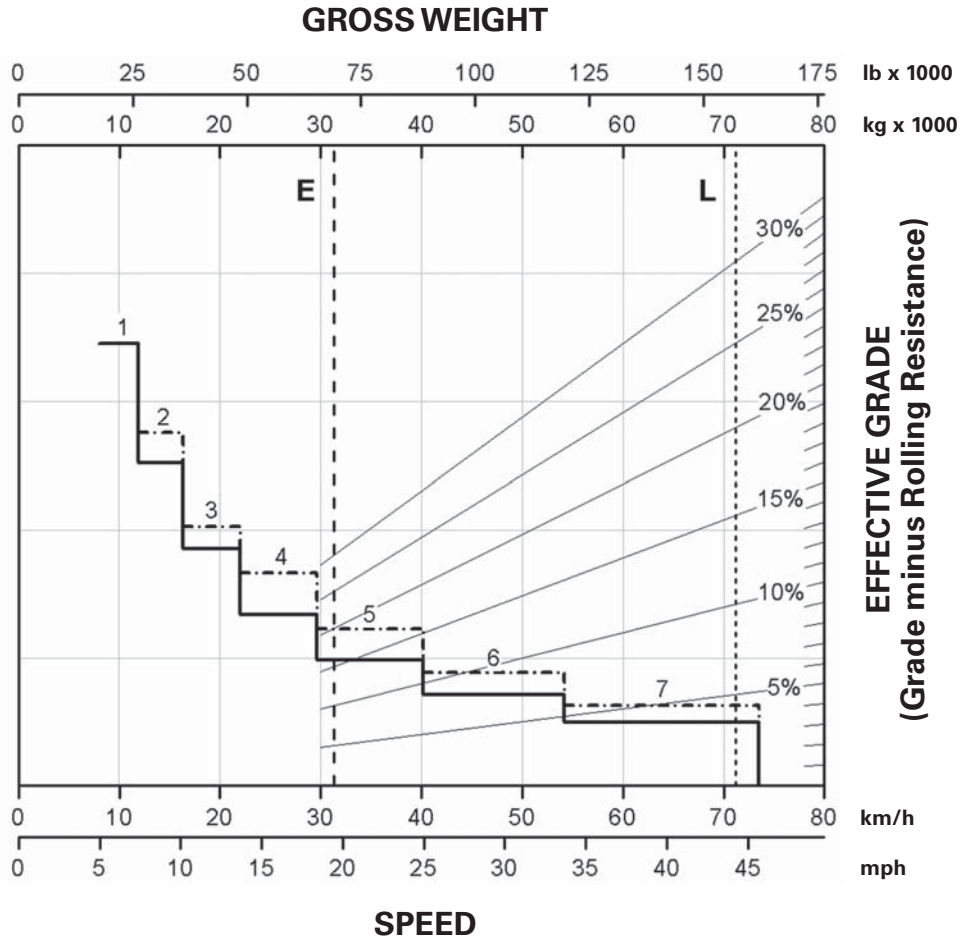

CONTINUOUS GRADE LENGTH

KEY

- 1 — 1st Gear
- 2 — 2nd Gear
- 3 — 3rd Gear
- 4 — 4th Gear
- 5 — 5th Gear
- 6 — 6th Gear
- 7 — 7th Gear

KEY

- E — Empty Weight 32 565 kg (71,793 lb)
- L — Target GMW 71 214 kg (157,000 lb)
- With ARC Only
- - - - - ARC and Engine Brake

770G Brake Performance

- 450 m (1500 ft)
- 600 m (2000 ft)
- 900 m (3000 ft)
- 1500 m (5000 ft)

GROSS WEIGHT

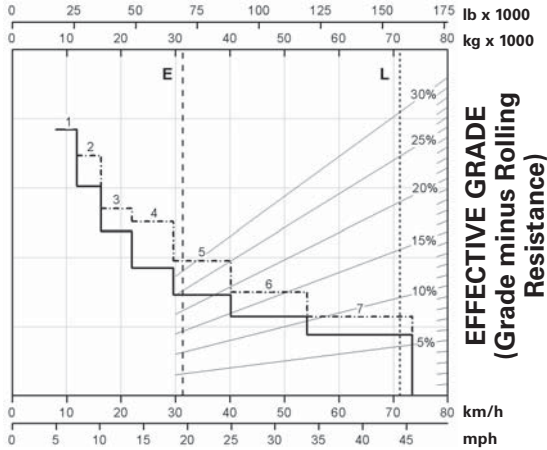

SPEED

GRADE DISTANCE — 450 m (1500 ft)

GROSS WEIGHT

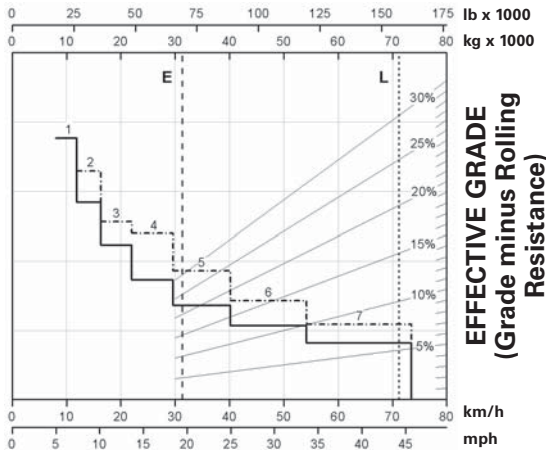

SPEED

GRADE DISTANCE — 600 m (2000 ft)

GROSS WEIGHT

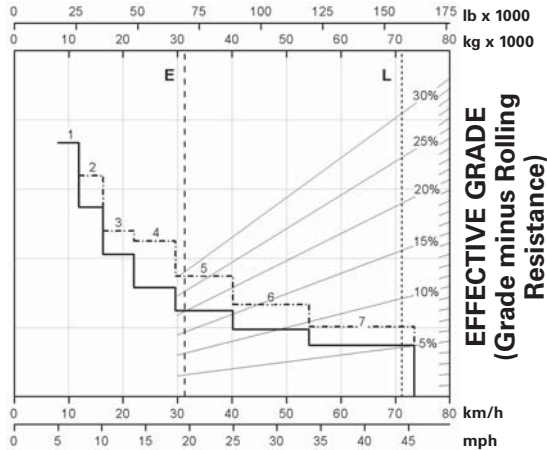

SPEED

GRADE DISTANCE — 900 m (3000 ft)

GROSS WEIGHT

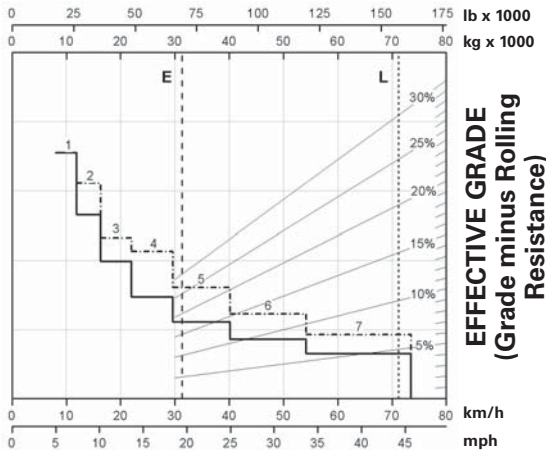

SPEED

GRADE DISTANCE — 1500 m (5000 ft)

KEY

- 1 — 1st Gear
- 2 — 2nd Gear
- 3 — 3rd Gear
- 4 — 4th Gear
- 5 — 5th Gear
- 6 — 6th Gear
- 7 — 7th Gear

KEY

- E — Empty Weight 32 565 kg (71,793 lb)
- L — Target GMW 71 214 kg (157,000 lb)
- With ARC Only
- - - - - ARC and Engine Brake

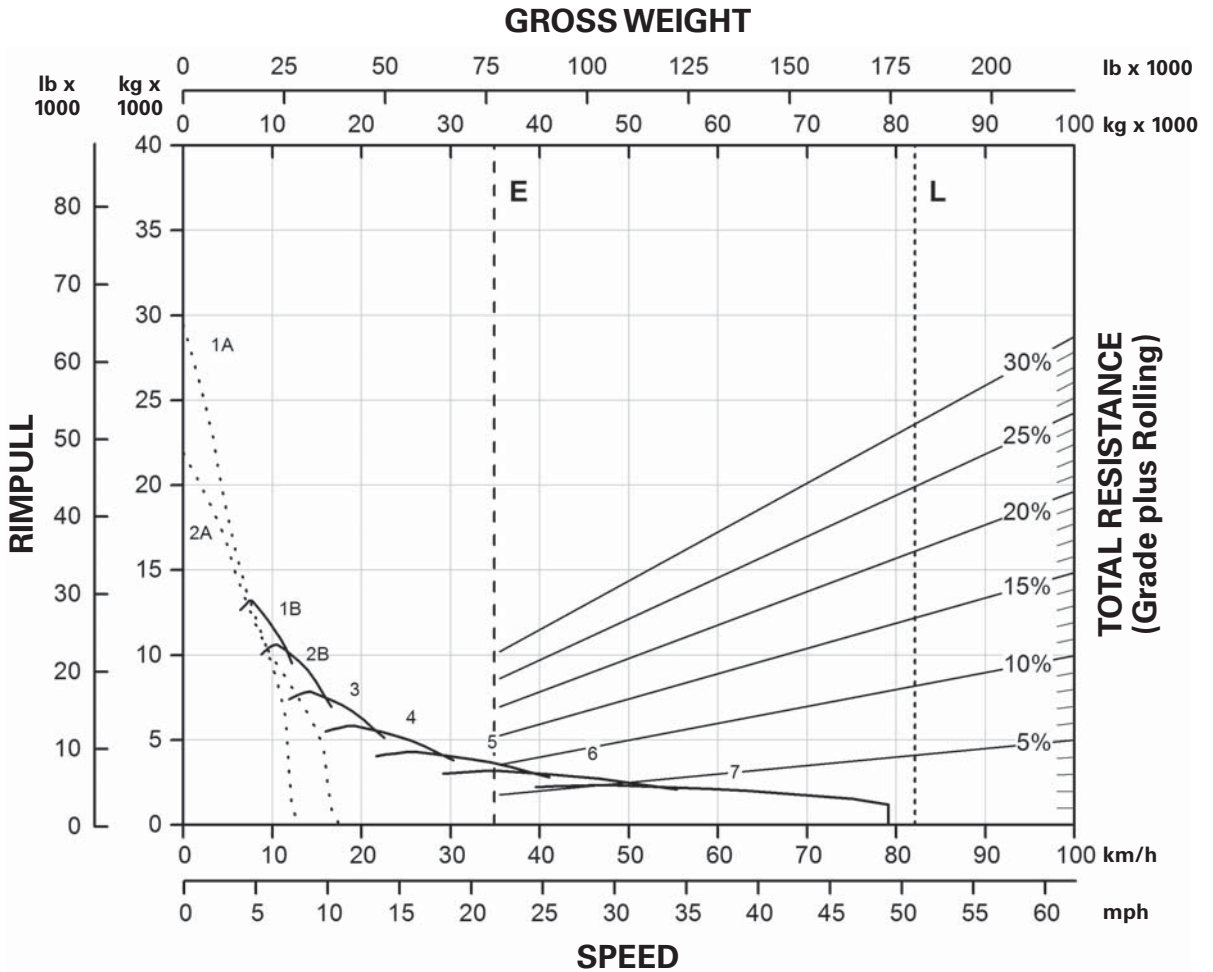

KEY

- 1A — 1st Gear (Torque Converter)
- 1B — 1st Gear
- 2 — 2nd Gear
- 3 — 3rd Gear
- 4 — 4th Gear
- 5 — 5th Gear
- 6 — 6th Gear
- 7 — 7th Gear

KEY

- E — Empty 34 893 kg (76,925 lb)
- L — Target GMW 82 100 kg (181,000 lb)

*Meets Tier 4 Final, Stage IV, and Japan 2014 (Tier 4 Final) emission standards.

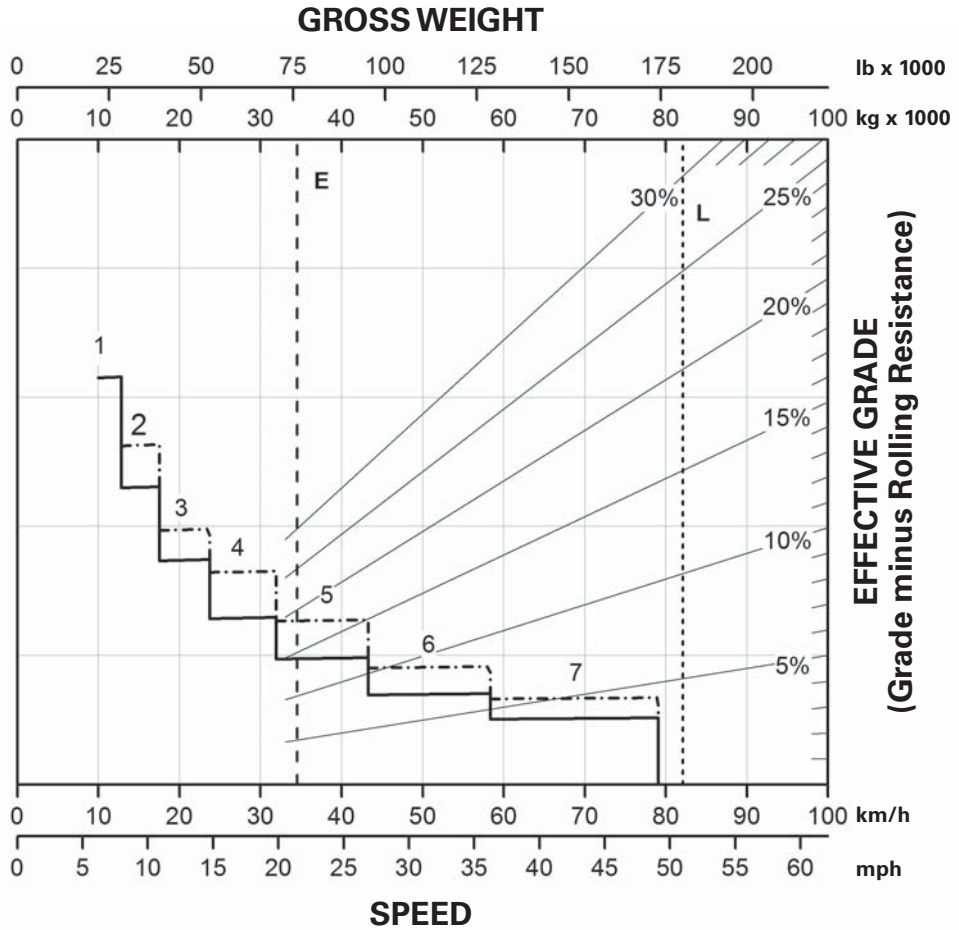

CONTINUOUS GRADE LENGTH

KEY

- 1 — 1st Gear
- 2 — 2nd Gear
- 3 — 3rd Gear
- 4 — 4th Gear
- 5 — 5th Gear
- 6 — 6th Gear
- 7 — 7th Gear

KEY

- E — Empty 34 893 kg (76,925 lb)
- L — Target GMW 82 100 kg (181,000 lb)
- With ARC Only
- - - - - ARC and Engine Brake

*Meets Tier 4 Final, Stage IV, and Japan 2014 (Tier 4 Final) emission standards.

Mining & Off-Highway Trucks

772G Tier 4 Final* Brake Performance

- 450 m (1500 ft)
- 600 m (2000 ft)
- 900 m (3000 ft)
- 1500 m (5000 ft)

GROSS WEIGHT

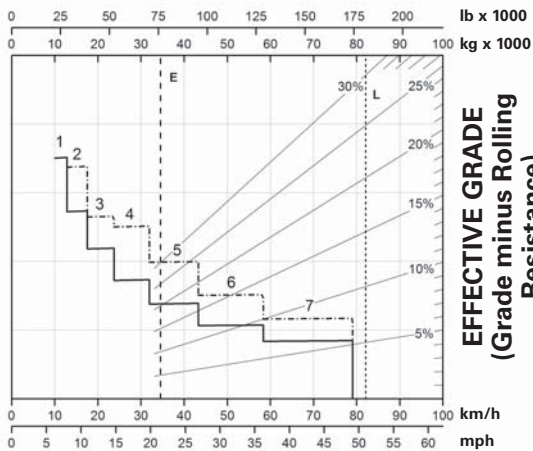

SPEED

GRADE DISTANCE — 450 m (1500 ft)

GROSS WEIGHT

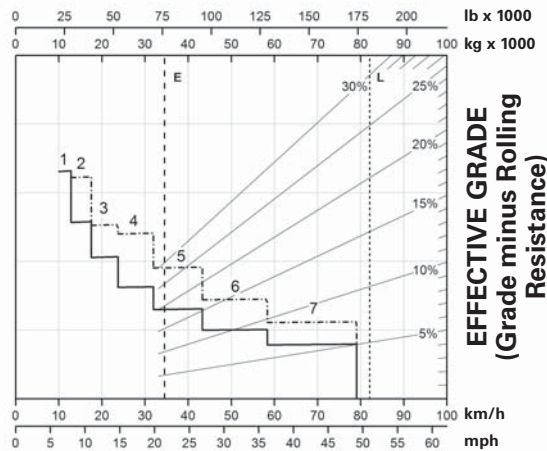

SPEED

GRADE DISTANCE — 600 m (2000 ft)

GROSS WEIGHT

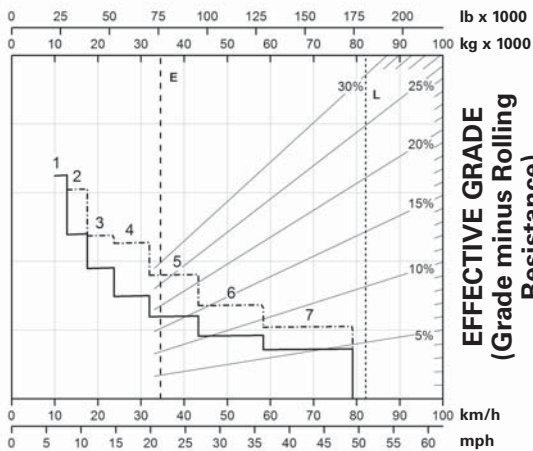

SPEED

GRADE DISTANCE — 900 m (3000 ft)

GROSS WEIGHT

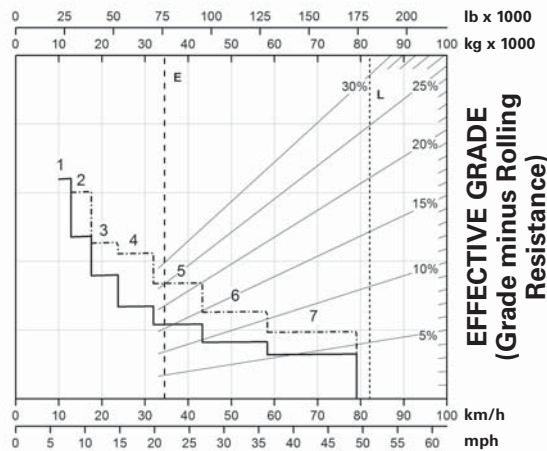

SPEED

GRADE DISTANCE — 1500 m (5000 ft)

KEY

- 1 — 1st Gear
- 2 — 2nd Gear
- 3 — 3rd Gear
- 4 — 4th Gear
- 5 — 5th Gear
- 6 — 6th Gear
- 7 — 7th Gear

KEY

- E — Empty 34 893 kg (76,925 lb)
- L — Target GMW 82 100 kg (181,000 lb)
- With ARC Only
- - - - - ARC and Engine Brake

*Meets Tier 4 Final, Stage IV, and Japan 2014 (Tier 4 Final) emission standards.

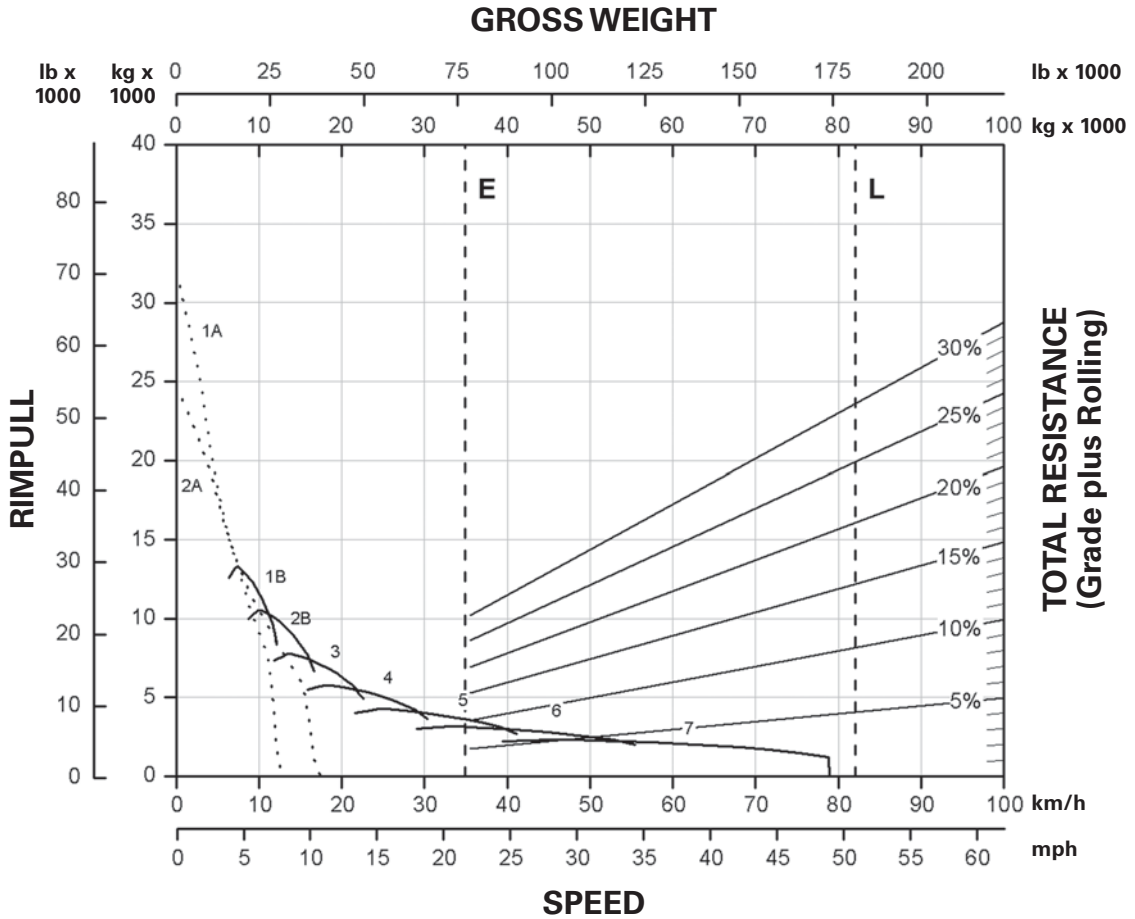

10

KEY

- 1A – 1st Gear (Torque Converter)
- 1B – 1st gear
- 2A – 2nd Gear (Torque Converter)
- 2B – 2nd Gear
- 3 – 3rd Gear
- 4 – 4th Gear
- 5 – 5th Gear
- 6 – 6th Gear
- 7 – 7th Gear

KEY

- E – Empty Weight 34 893 kg (76,925 lb)
- L – Target GMW 82 100 kg (181,000 lb)

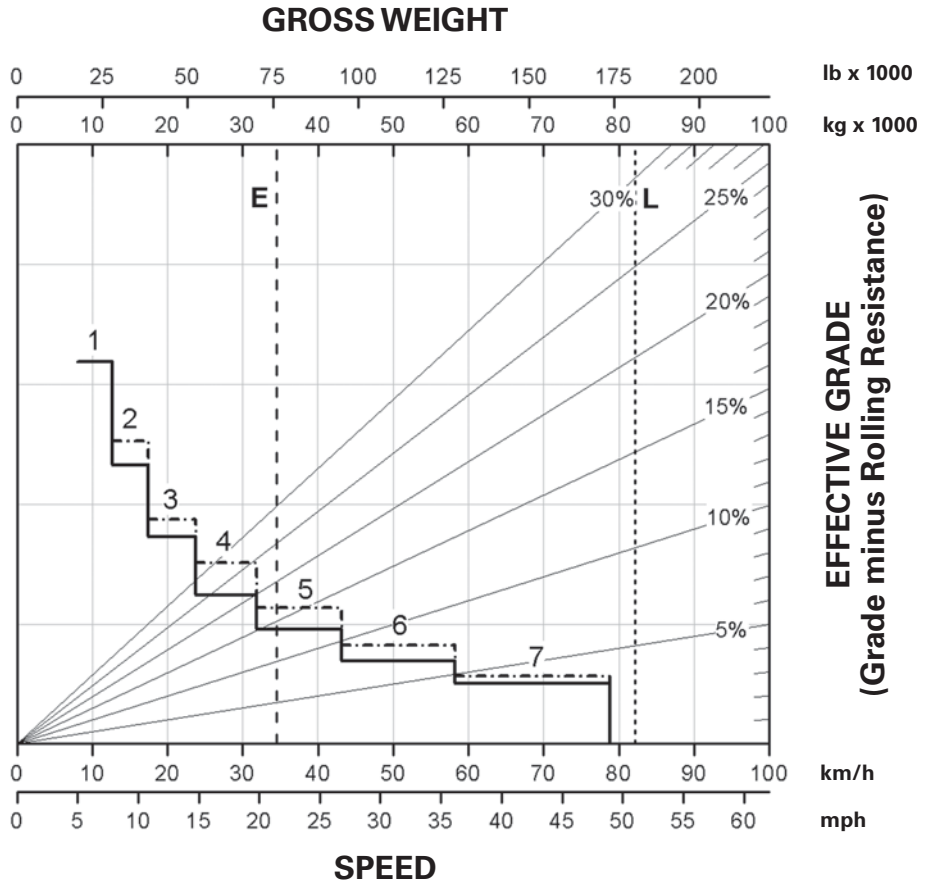

CONTINUOUS GRADE LENGTH

KEY

- 1 — 1st Gear
- 2 — 2nd Gear
- 3 — 3rd Gear
- 4 — 4th Gear
- 5 — 5th Gear
- 6 — 6th Gear
- 7 — 7th Gear

KEY

- E — Empty Weight 34 893 kg (76,925 lb)
- L — Target GMW 82 100 kg (181,000 lb)
- With ARC Only
- - - - - ARC and Engine Brake

772G Brake Performance

- 450 m (1500 ft)
- 600 m (2000 ft)
- 900 m (3000 ft)
- 1500 m (5000 ft)

GROSS WEIGHT

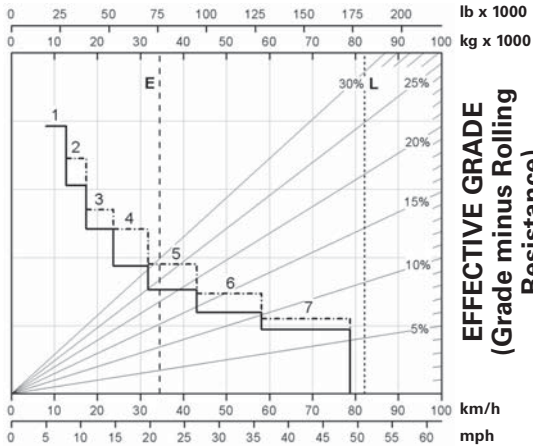

SPEED
GRADE DISTANCE — 450 m (1500 ft)

GROSS WEIGHT

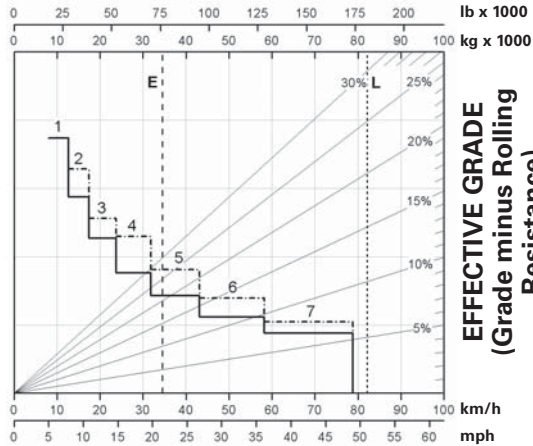

SPEED
GRADE DISTANCE — 600 m (2000 ft)

GROSS WEIGHT

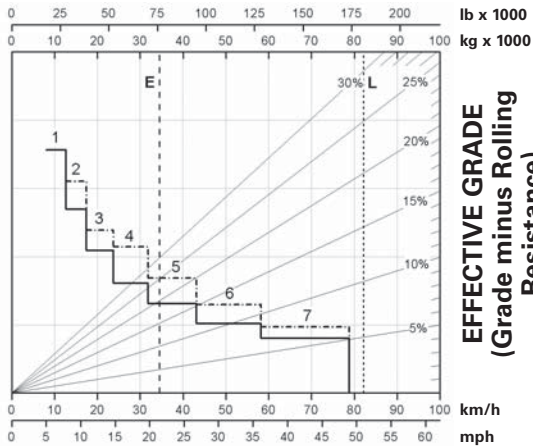

SPEED
GRADE DISTANCE — 900 m (3000 ft)

GROSS WEIGHT

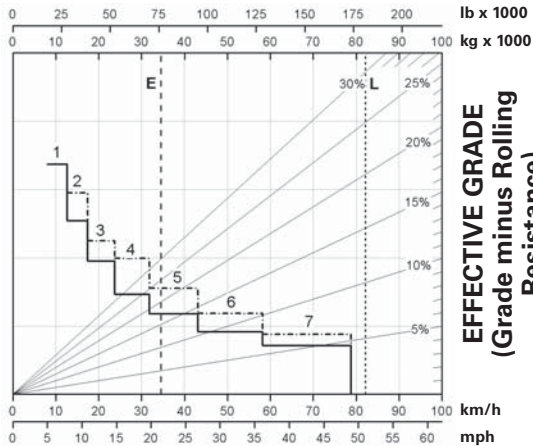

SPEED
GRADE DISTANCE — 1500 m (5000 ft)

KEY

- 1 – 1st Gear
- 2 – 2nd Gear
- 3 – 3rd Gear
- 4 – 4th Gear
- 5 – 5th Gear
- 6 – 6th Gear
- 7 – 7th Gear

KEY

- E — Empty Weight 34 893 kg (76,925 lb)
- L — Target GMW 82 100 kg (181,000 lb)
- With ARC Only
- - - - - ARC and Engine Brake

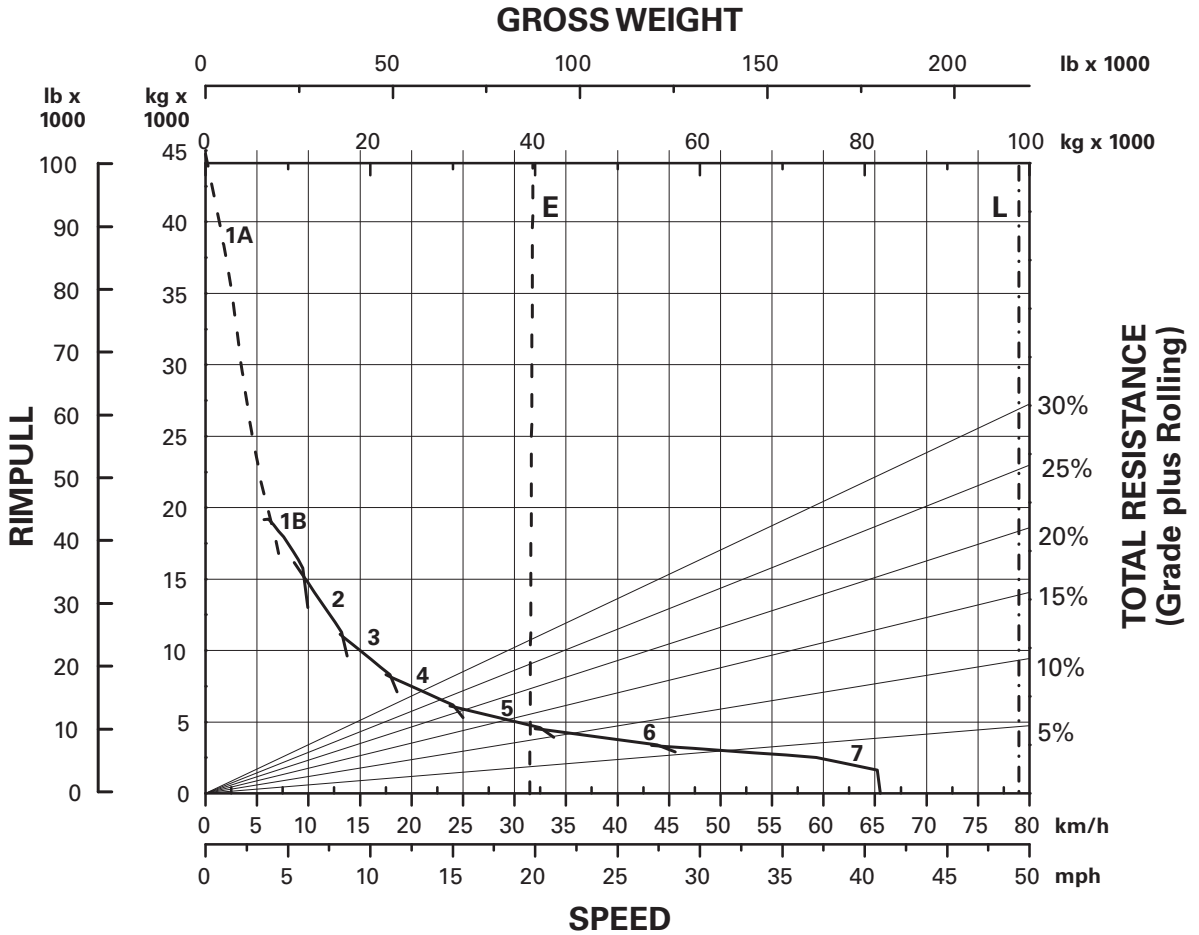

KEY

- 1A — 1st Gear (Torque Converter)
- 1B — 1st Gear
- 2 — 2nd Gear
- 3 — 3rd Gear
- 4 — 4th Gear
- 5 — 5th Gear
- 6 — 6th Gear
- 7 — 7th Gear

KEY

- E — Empty Weight 39 940 kg (88,053 lb)
- L — Target GMW 99 300 kg (219,000 lb)

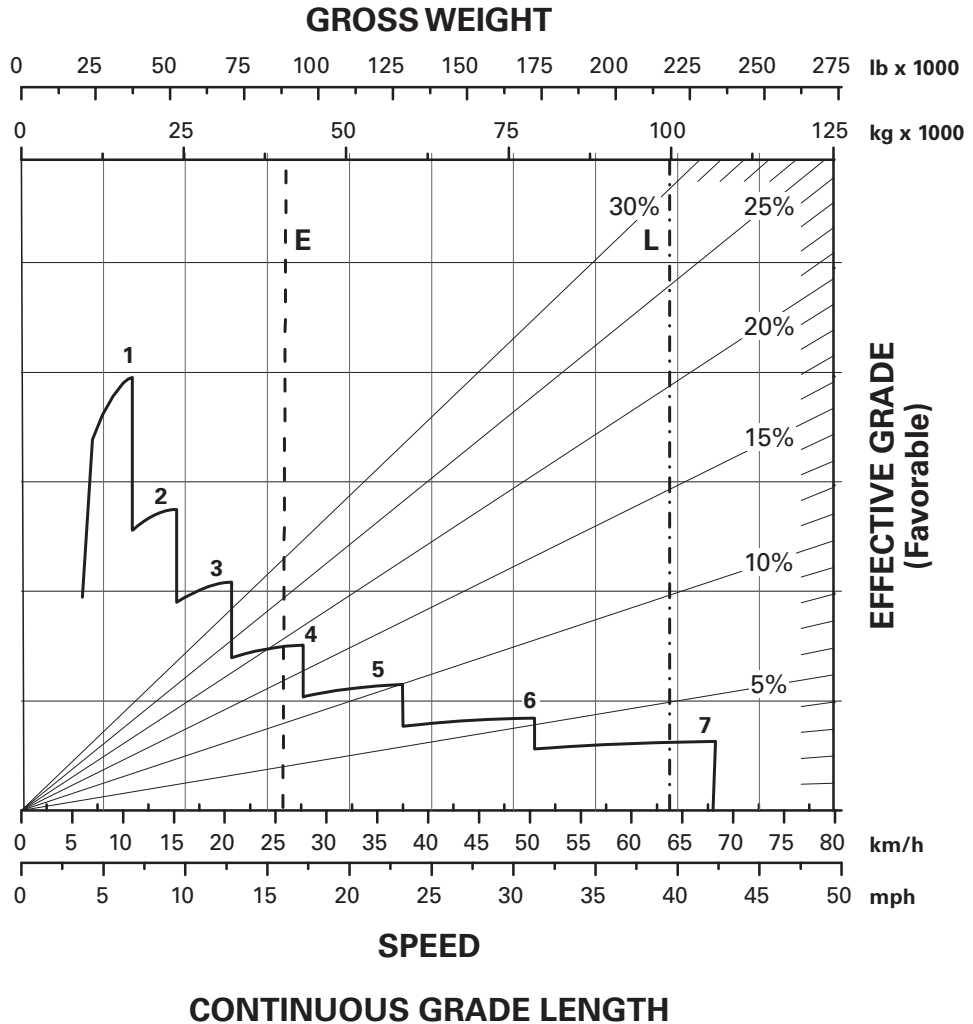

KEY

- 1 — 1st Gear
- 2 — 2nd Gear
- 3 — 3rd Gear
- 4 — 4th Gear
- 5 — 5th Gear
- 6 — 6th Gear
- 7 — 7th Gear

KEY

- E — Empty Weight 39 940 kg (88,053 lb)
- L — Target GMW 99 300 kg (219,000 lb)

Mining & Off-Highway Trucks

773E Brake Performance

- 450 m (1500 ft)
- 600 m (2000 ft)
- 900 m (3000 ft)
- 1500 m (5000 ft)

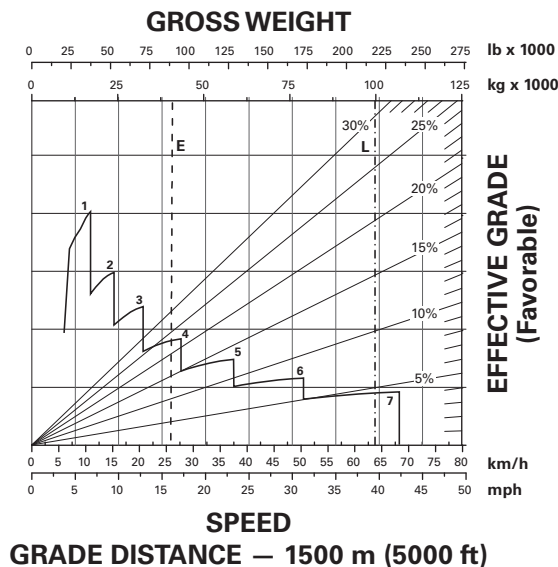
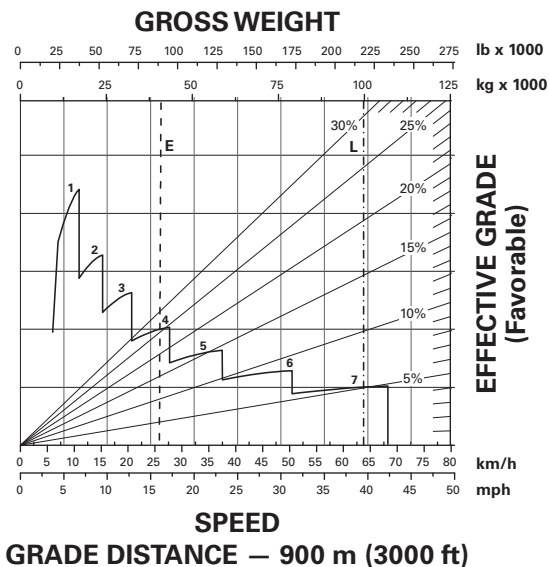
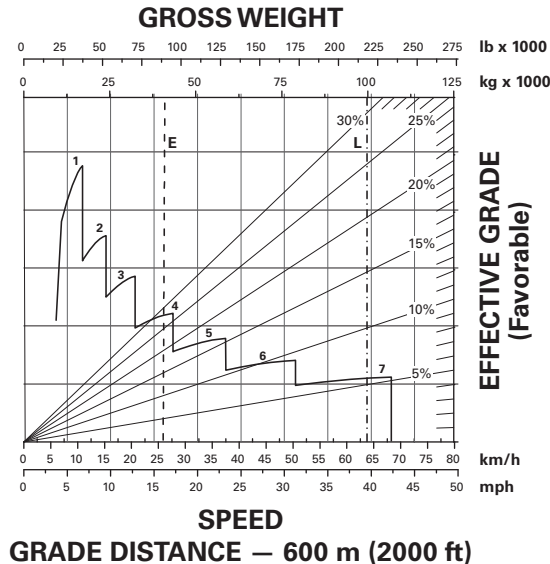
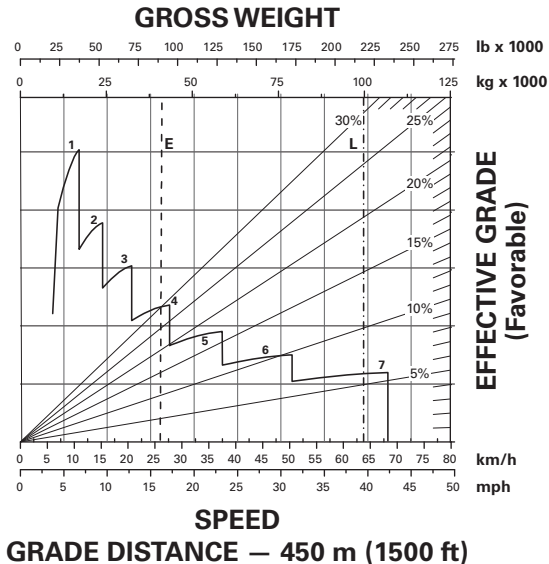

KEY

- 1 — 1st Gear
- 2 — 2nd Gear
- 3 — 3rd Gear
- 4 — 4th Gear
- 5 — 5th Gear
- 6 — 6th Gear
- 7 — 7th Gear

KEY

- E — Empty Weight 39 940 kg (88,053 lb)
- L — Target GMW 99 300 kg (219,000 lb)

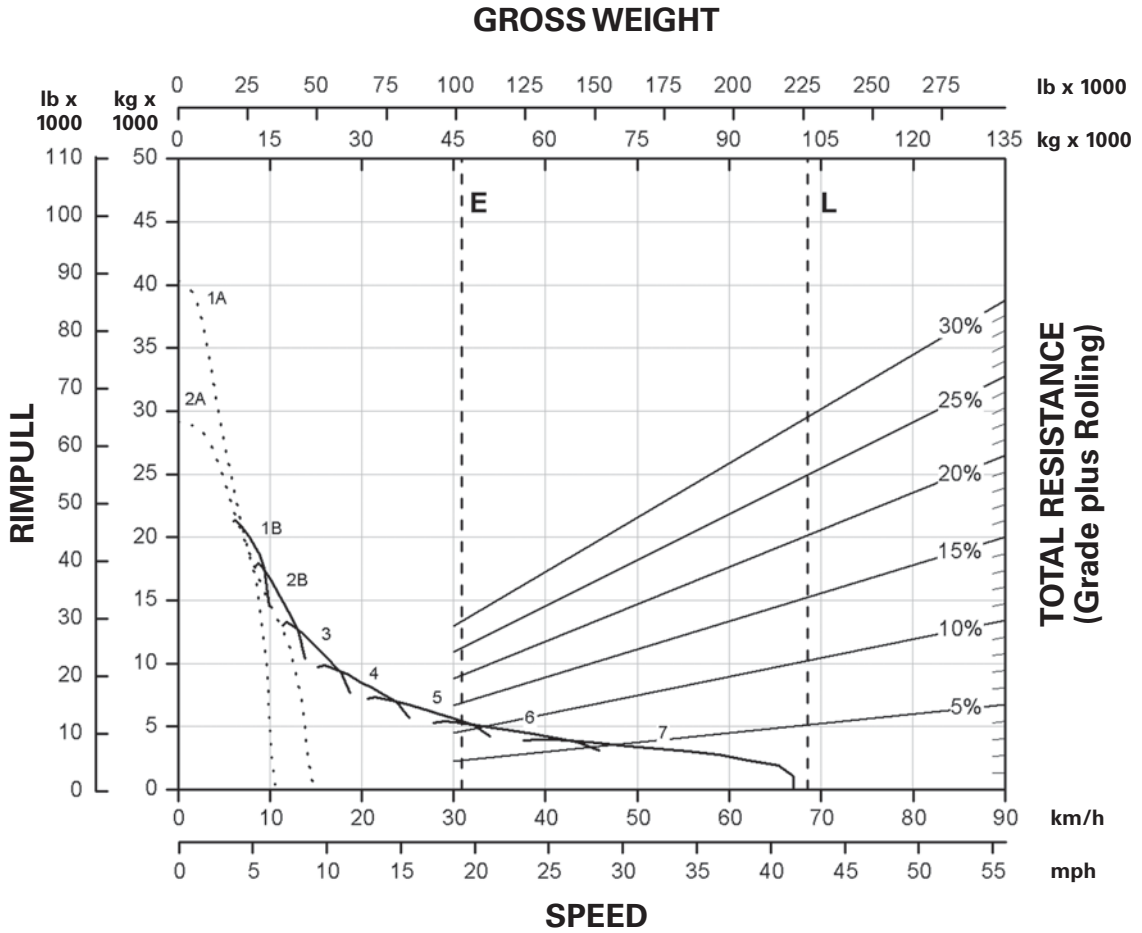

KEY

- 1A — 1st Gear (Torque Converter)
- 1B — 1st Gear
- 2A — 2nd Gear (Torque Converter)
- 2B — 2nd Gear
- 3 — 3rd Gear
- 4 — 4th Gear
- 5 — 5th Gear
- 6 — 6th Gear
- 7 — 7th Gear

KEY

- E — Empty 46 239 kg (101,726 lb)
- L — Target GMW 102 739 kg (226,500 lb)

GROSS WEIGHT

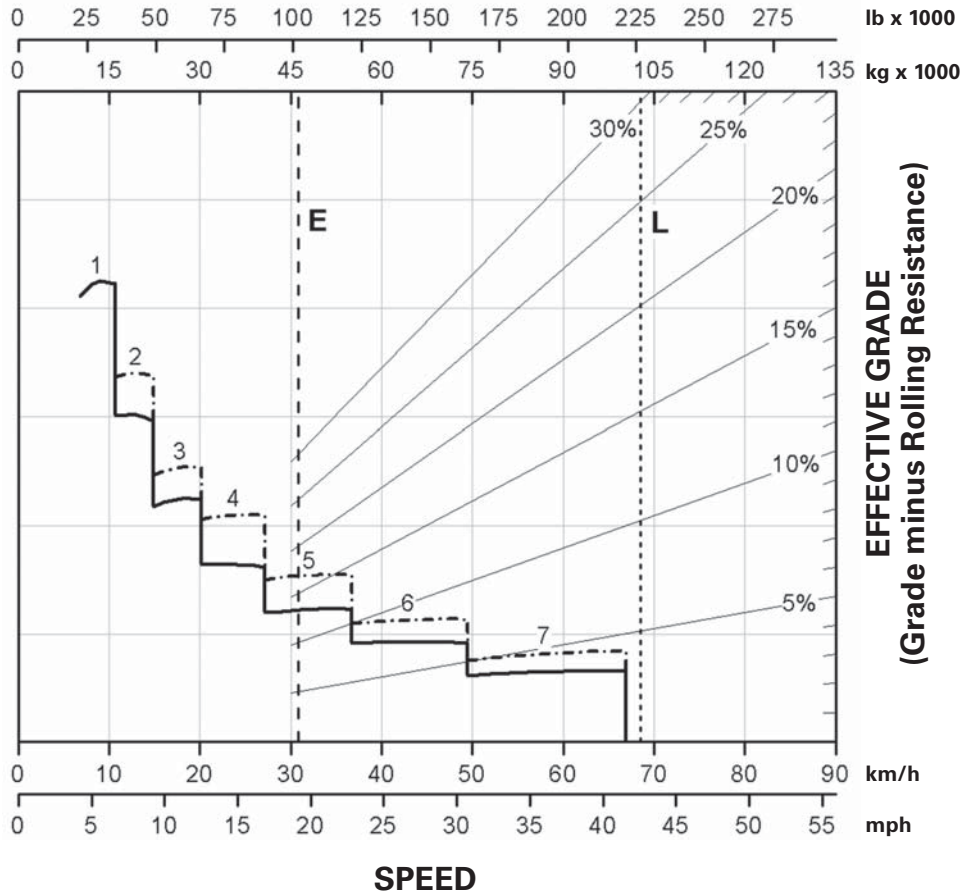

CONTINUOUS GRADE LENGTH

KEY

- 1 — 1st Gear
- 2 — 2nd Gear
- 3 — 3rd Gear
- 4 — 4th Gear
- 5 — 5th Gear
- 6 — 6th Gear
- 7 — 7th Gear

KEY

- E — Empty 46 239 kg (101,726 lb)
- L — Target GMW 102 739 kg (226,500 lb)
- With ARC Only
- ARC and Engine Brake

773G Tier 4 Final Brake Performance

- 450 m (1500 ft)
- 600 m (2000 ft)
- 900 m (3000 ft)
- 1500 m (5000 ft)

Mining & Off-Highway Trucks

GROSS WEIGHT

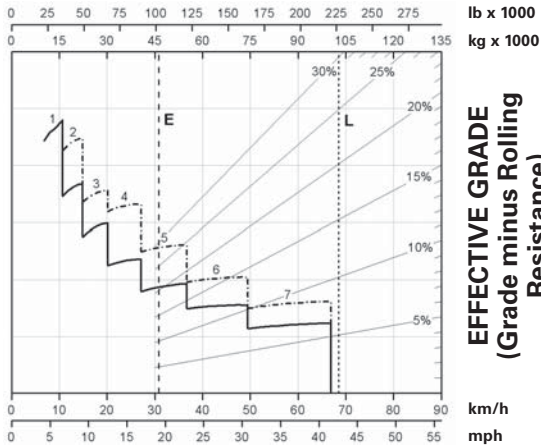

SPEED

GRADE DISTANCE — 450 m (1500 ft)

GROSS WEIGHT

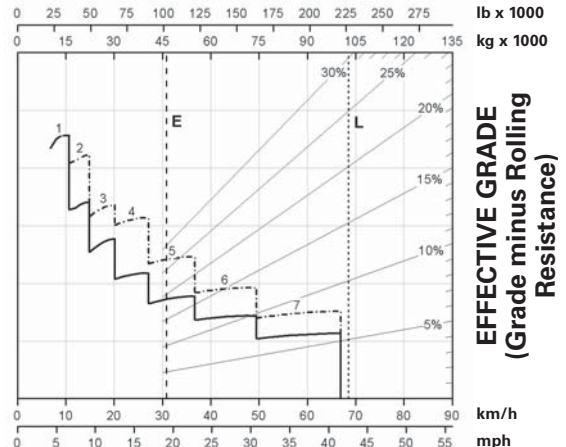

SPEED

GRADE DISTANCE — 600 m (2000 ft)

GROSS WEIGHT

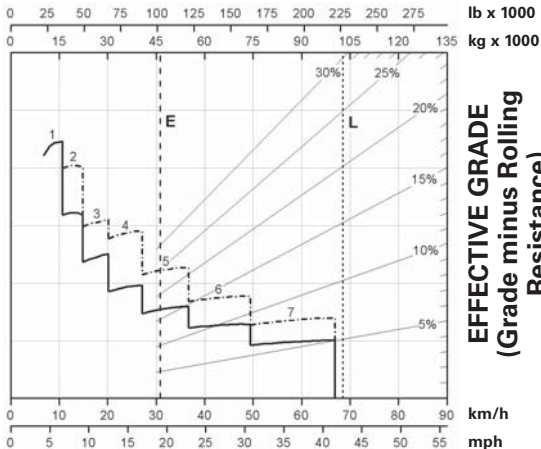

SPEED

GRADE DISTANCE — 900 m (3000 ft)

GROSS WEIGHT

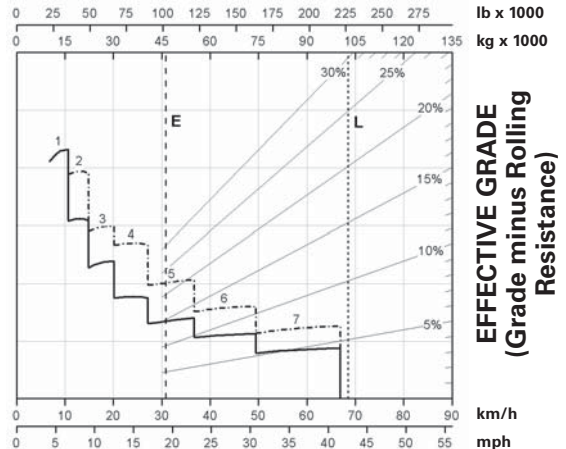

SPEED

GRADE DISTANCE — 1500 m (5000 ft)

KEY

- 1 — 1st Gear
- 2 — 2nd Gear
- 3 — 3rd Gear
- 4 — 4th Gear
- 5 — 5th Gear
- 6 — 6th Gear
- 7 — 7th Gear

KEY

- E — Empty 46 239 kg (101,726 lb)
- L — Target GMW 102 739 kg (226,500 lb)
- With ARC Only
- - - - - ARC and Engine Brake

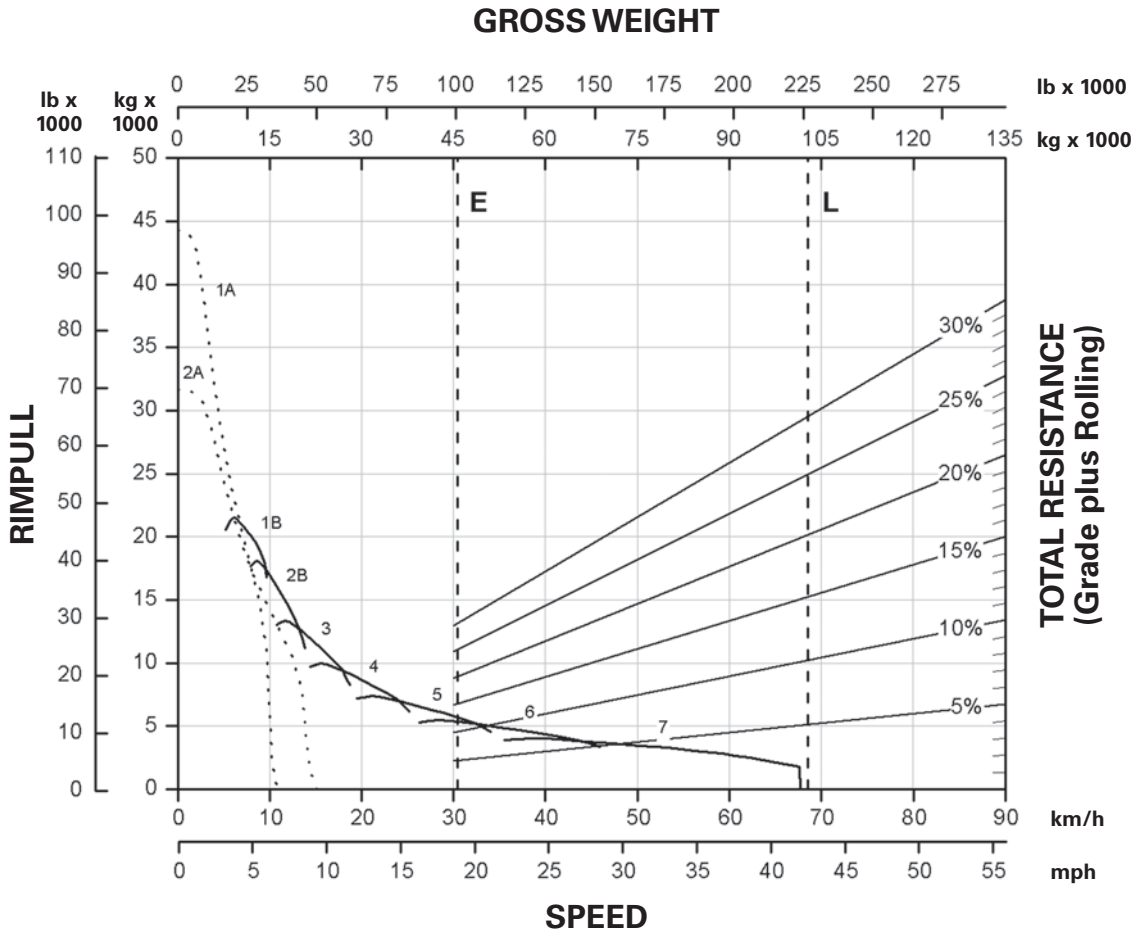

KEY

- 1A — 1st Gear (Torque Converter)
- 1B — 1st Gear
- 2A — 2nd Gear (Torque Converter)
- 2B — 2nd Gear
- 3 — 3rd Gear
- 4 — 4th Gear
- 5 — 5th Gear
- 6 — 6th Gear
- 7 — 7th Gear

KEY

- E — Empty 45 585 kg (100,286 lb)
- L — Target GMW 102 739 kg (226,500 lb)

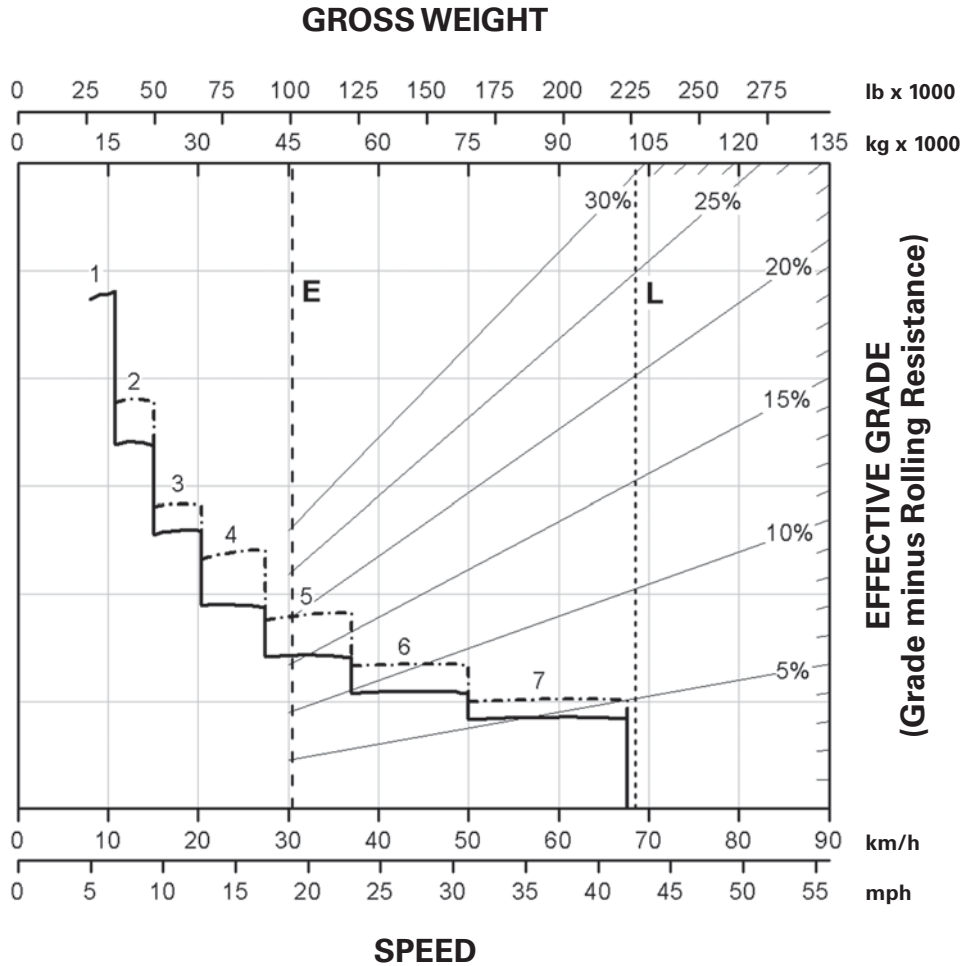

KEY

- 1 — 1st Gear
- 2 — 2nd Gear
- 3 — 3rd Gear
- 4 — 4th Gear
- 5 — 5th Gear
- 6 — 6th Gear
- 7 — 7th Gear

KEY

- E — Empty 45 585 kg (100,286 lb)
- L — Target GMW 102 739 kg (226,500 lb)
- With ARC Only
- ARC and Engine Brake

Mining & Off-Highway Trucks

773G Brake Performance

- 450 m (1500 ft) ● 600 m (2000 ft)
- 900 m (3000 ft) ● 1500 m (5000 ft)

GROSS WEIGHT

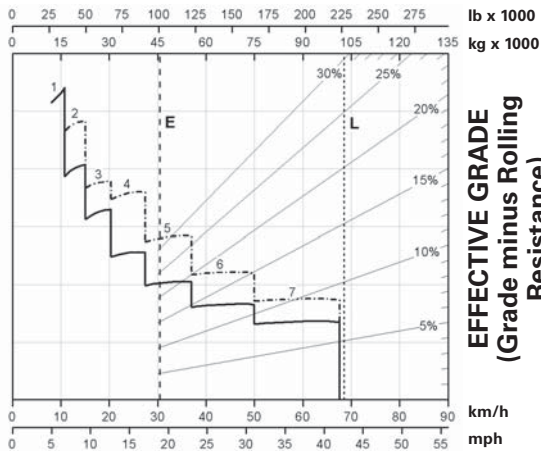

SPEED

GRADE DISTANCE — 450 m (1500 ft)

GROSS WEIGHT

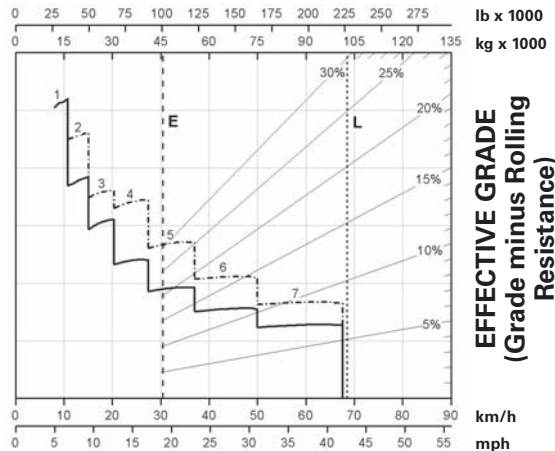

SPEED

GRADE DISTANCE — 600 m (2000 ft)

GROSS WEIGHT

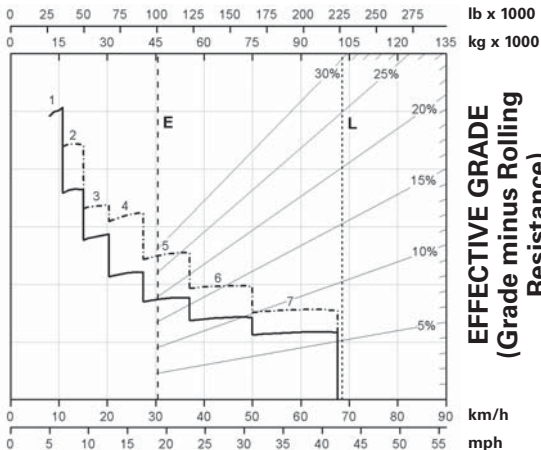

SPEED

GRADE DISTANCE — 900 m (3000 ft)

GROSS WEIGHT

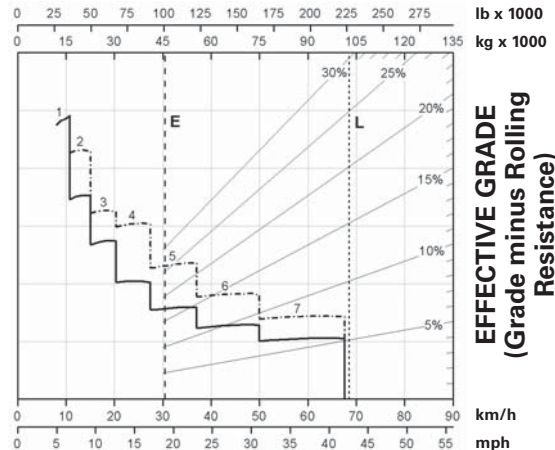

SPEED

GRADE DISTANCE — 1500 m (5000 ft)

KEY

- 1 — 1st Gear
- 2 — 2nd Gear
- 3 — 3rd Gear
- 4 — 4th Gear
- 5 — 5th Gear
- 6 — 6th Gear
- 7 — 7th Gear

KEY

- E — Empty 45 585 kg (100,286 lb)
- L — Target GMW 102 739 kg (226,500 lb)
- With ARC Only
- ARC and Engine Brake

GROSS WEIGHT

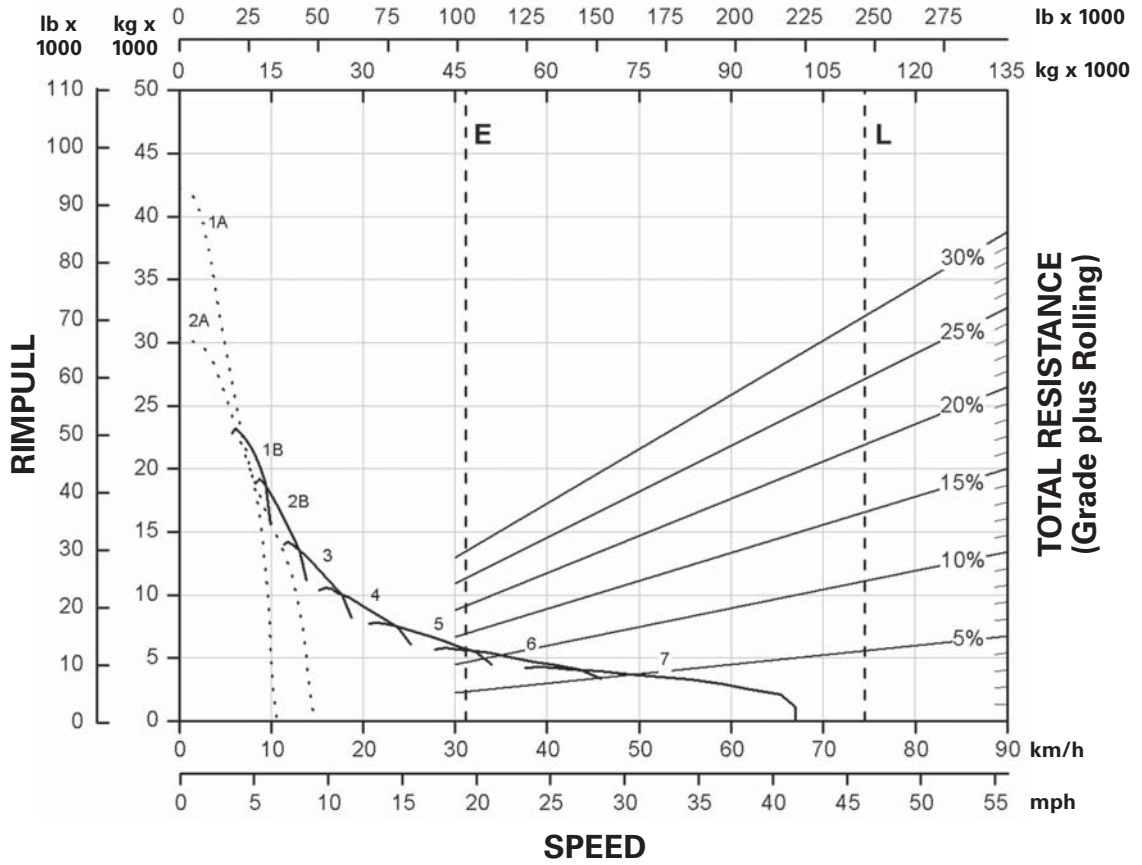

KEY

- 1A — 1st Gear (Torque Converter)
- 1B — 1st Gear
- 2A — 2nd Gear (Torque Converter)
- 2B — 2nd Gear
- 3 — 3rd Gear
- 4 — 4th Gear
- 5 — 5th Gear
- 6 — 6th Gear
- 7 — 7th Gear

KEY

- E — Empty 46 747 kg (102,842 lb)
- L — Target GMW 111 811 kg (246,500 lb)

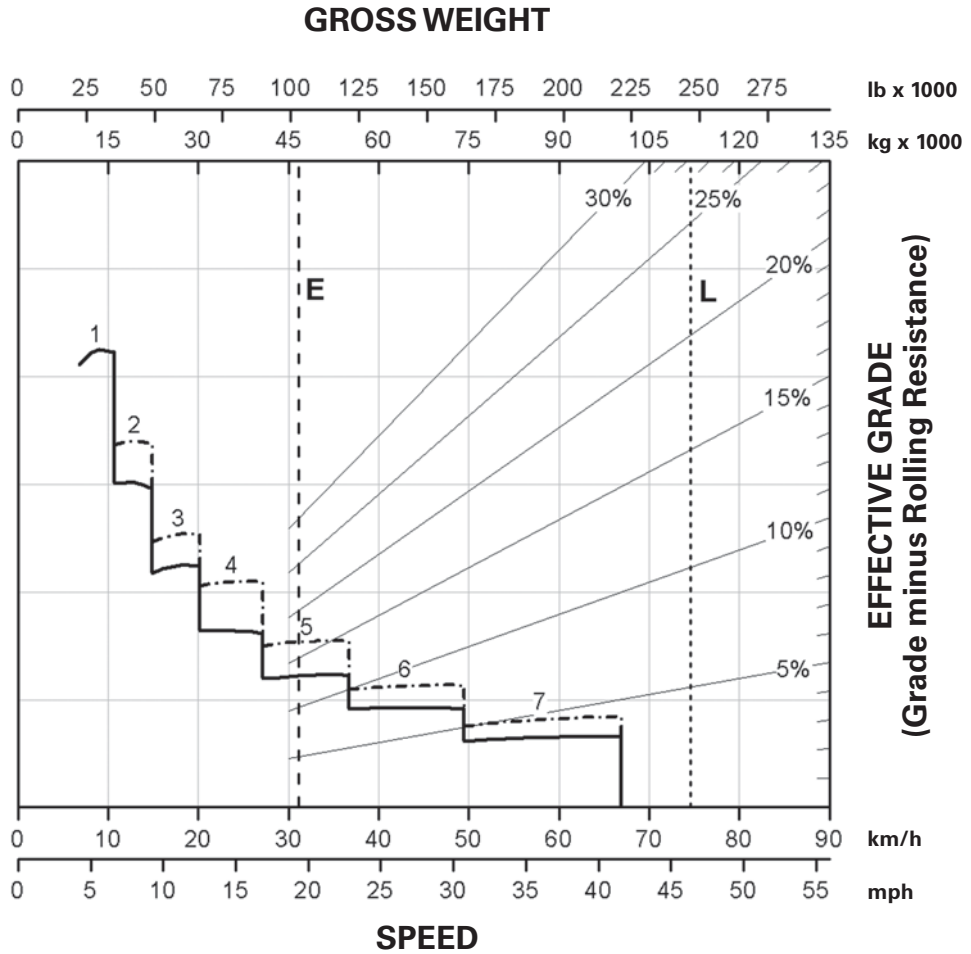

CONTINUOUS GRADE LENGTH

KEY

- 1 – 1st Gear
- 2 – 2nd Gear
- 3 – 3rd Gear
- 4 – 4th Gear
- 5 – 5th Gear
- 6 – 6th Gear
- 7 – 7th Gear

KEY

- E – Empty 46 747 kg (102,842 lb)
- L – Target GMW 111 811 kg (246,500 lb)
- With ARC Only
- - - - - ARC and Engine Brake

775G Tier 4 Final Brake Performance

- 450 m (1500 ft)
- 600 m (2000 ft)
- 900 m (3000 ft)
- 1500 m (5000 ft)

Mining & Off-Highway Trucks

GROSS WEIGHT

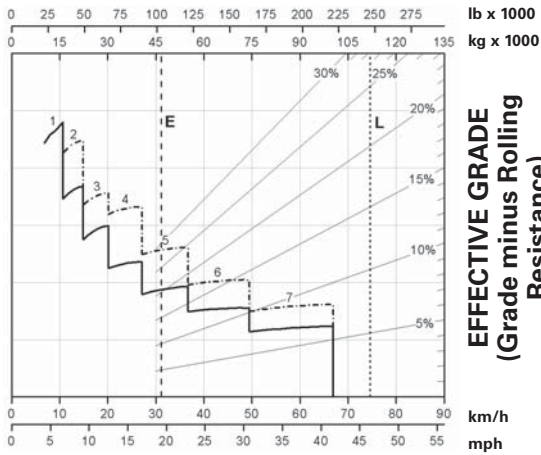

SPEED
GRADE DISTANCE — 450 m (1500 ft)

GROSS WEIGHT

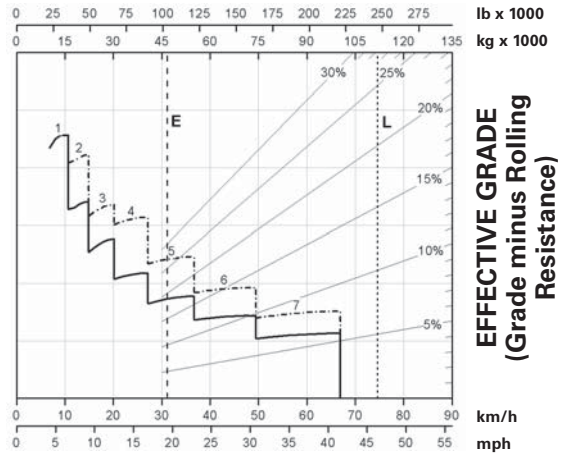

SPEED
GRADE DISTANCE — 600 m (2000 ft)

GROSS WEIGHT

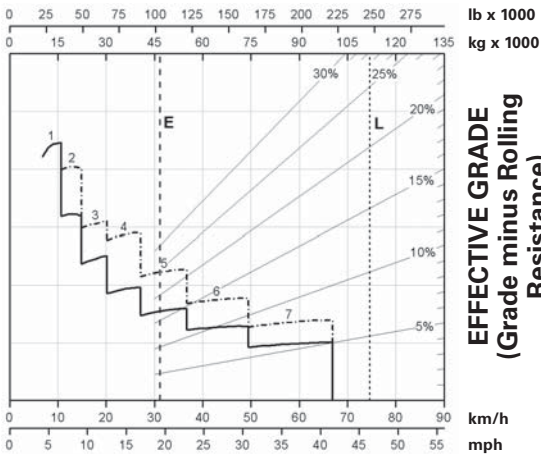

SPEED
GRADE DISTANCE — 900 m (3000 ft)

GROSS WEIGHT

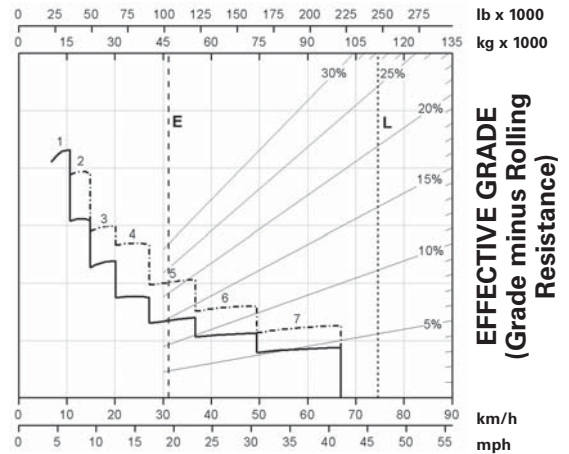

SPEED
GRADE DISTANCE — 1500 m (5000 ft)

KEY

- 1 — 1st Gear
- 2 — 2nd Gear
- 3 — 3rd Gear
- 4 — 4th Gear
- 5 — 5th Gear
- 6 — 6th Gear
- 7 — 7th Gear

KEY

- E — Empty 46 747 kg (102,842 lb)
- L — Target GMW 111 811 kg (246,500 lb)
- With ARC Only
- - - - - ARC and Engine Brake

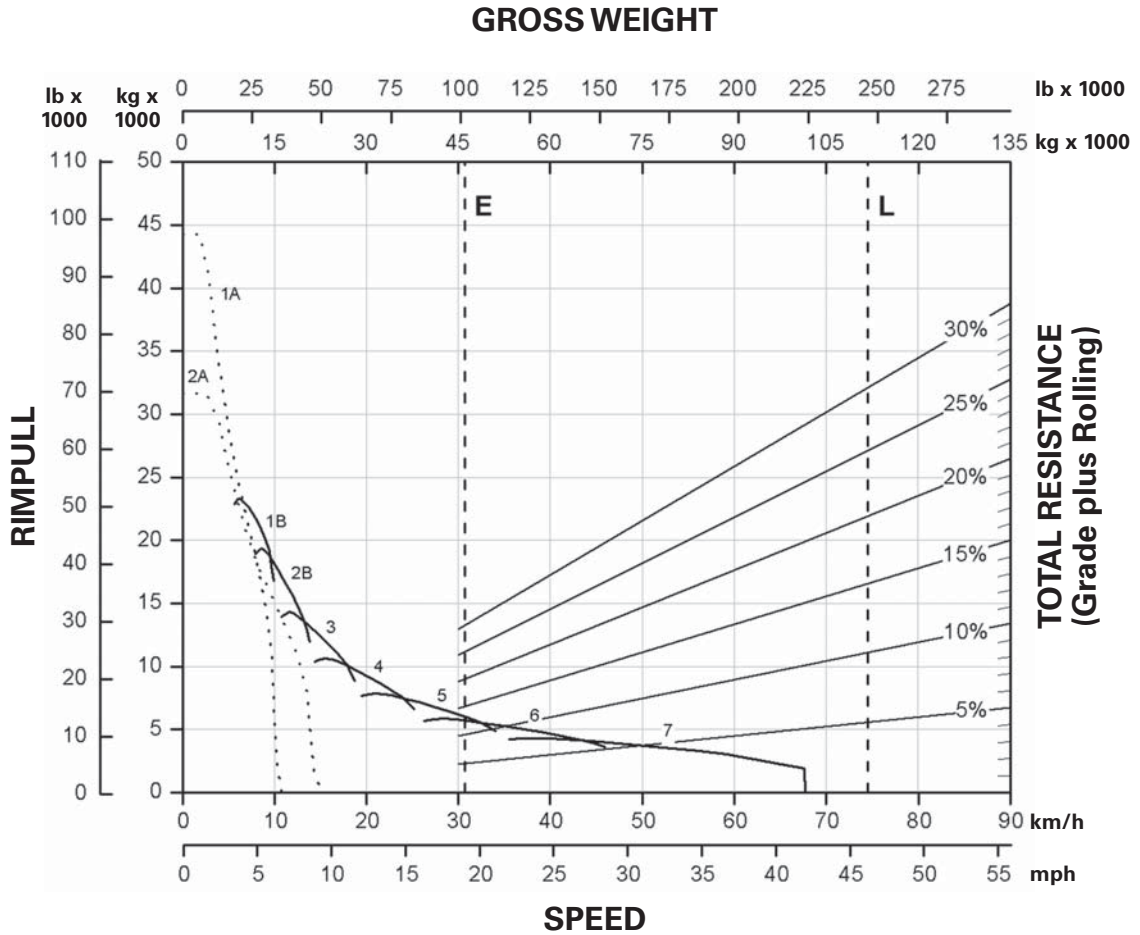

KEY

- 1A — 1st Gear (Torque Converter)
- 1B — 1st Gear
- 2A — 2nd Gear (Torque Converter)
- 2B — 2nd Gear
- 3 — 3rd Gear
- 4 — 4th Gear
- 5 — 5th Gear
- 6 — 6th Gear
- 7 — 7th Gear

KEY

- E — Empty 46 087 kg (101,392 lb)
- L — Target GMW 111 811 kg (246,500 lb)

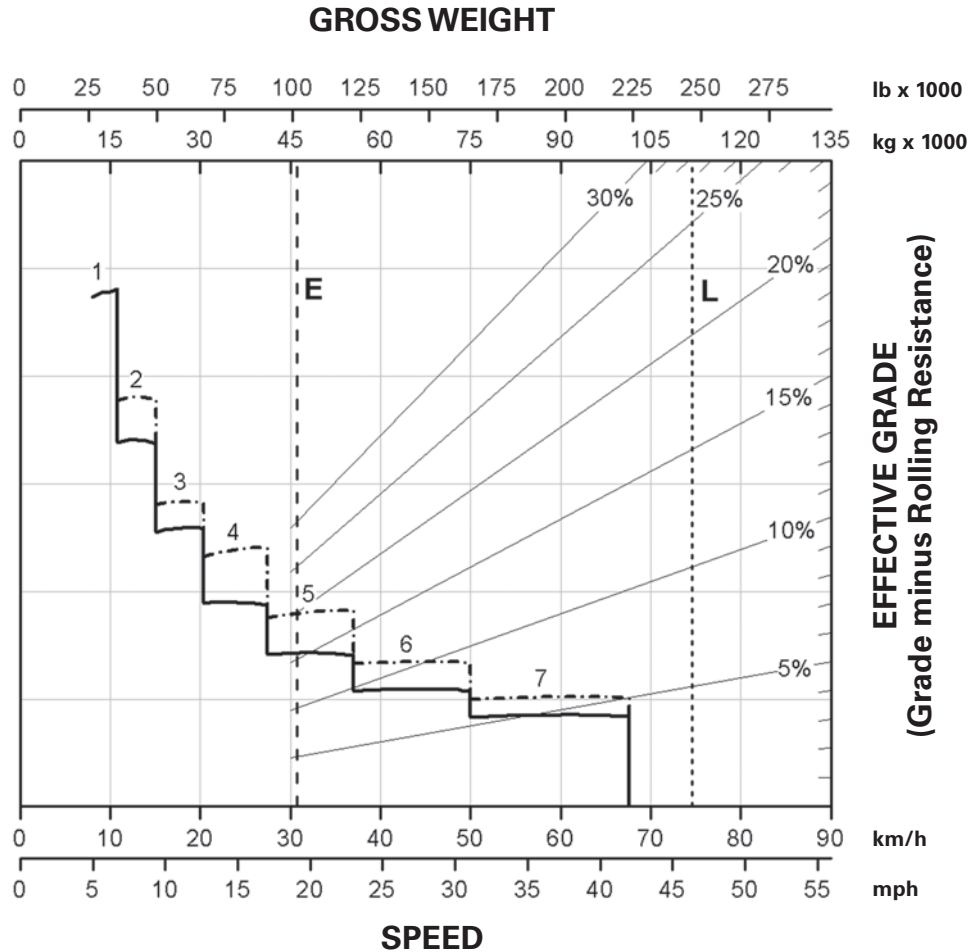

CONTINUOUS GRADE LENGTH

KEY

- 1 — 1st Gear
- 2 — 2nd Gear
- 3 — 3rd Gear
- 4 — 4th Gear
- 5 — 5th Gear
- 6 — 6th Gear
- 7 — 7th Gear

KEY

- E — Empty 46 087 kg (101,392 lb)
- L — Target GMW 111 811 kg (246,500 lb)
- With ARC Only
- - - - - ARC and Engine Brake

Mining & Off-Highway Trucks

775G Brake Performance

- 450 m (1500 ft)
- 600 m (2000 ft)
- 900 m (3000 ft)
- 1500 m (5000 ft)

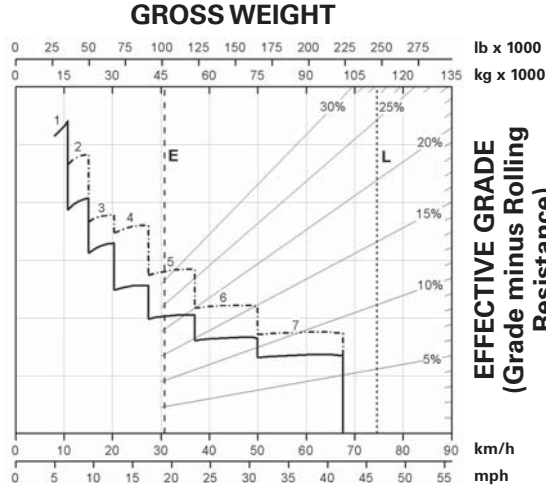

GRADE DISTANCE — 450 m (1500 ft)

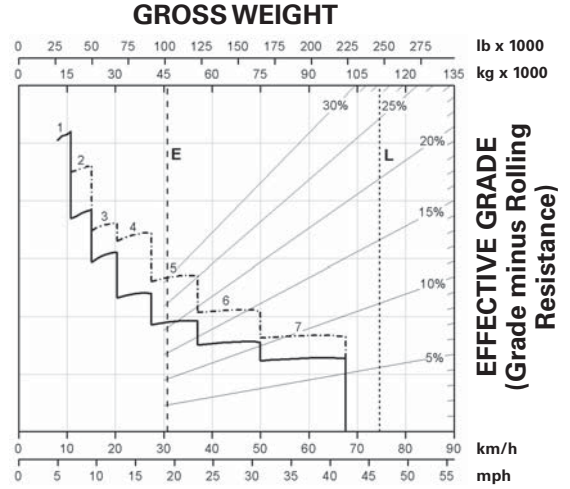

GRADE DISTANCE — 600 m (2000 ft)

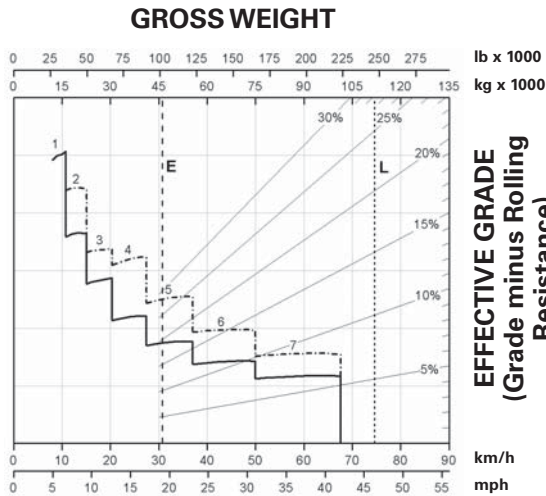

GRADE DISTANCE — 900 m (3000 ft)

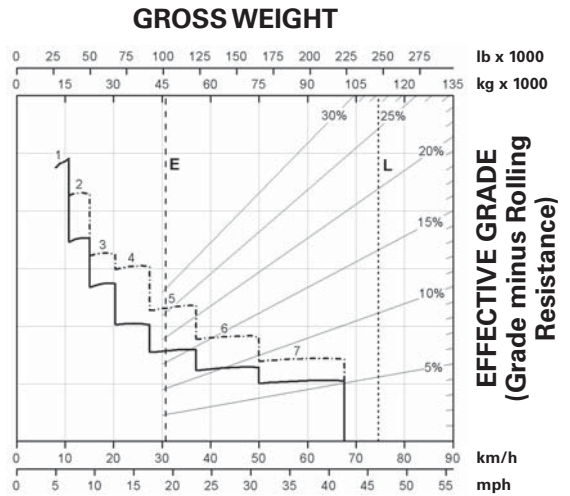

GRADE DISTANCE — 1500 m (5000 ft)

KEY

- 1 — 1st Gear
- 2 — 2nd Gear
- 3 — 3rd Gear
- 4 — 4th Gear
- 5 — 5th Gear
- 6 — 6th Gear
- 7 — 7th Gear

KEY

- E — Empty 46 087 kg (101,392 lb)
- L — Target GMW 111 811 kg (246,500 lb)
- With ARC Only
- - - - - ARC and Engine Brake

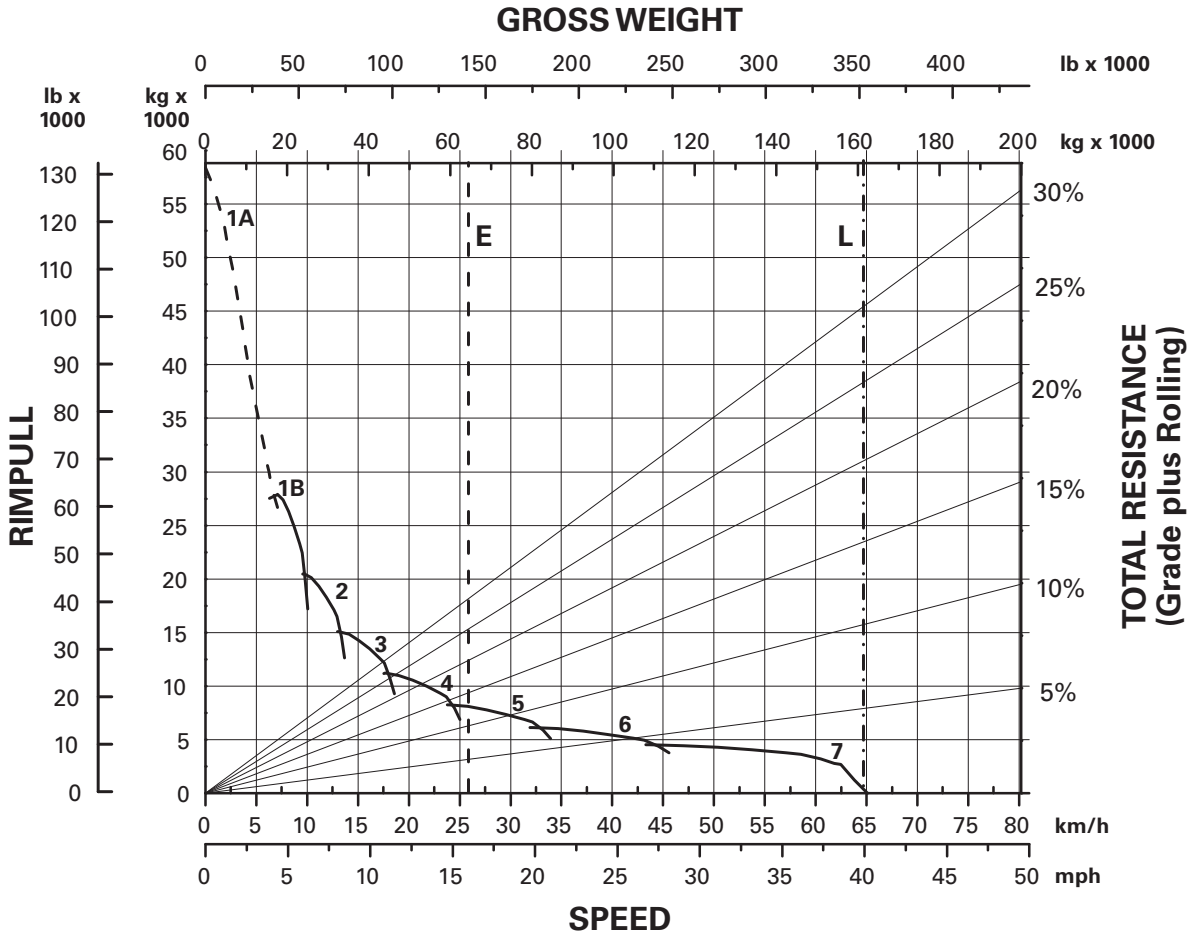

KEY

- 1A — 1st Gear (Torque Converter)
- 1B — 1st Gear
- 2 — 2nd Gear
- 3 — 3rd Gear
- 4 — 4th Gear
- 5 — 5th Gear
- 6 — 6th Gear
- 7 — 7th Gear

KEY

- E — Empty 64 359 kg (141,889 lb)
- L — Max GMW 163 360 kg (360,143 lb)

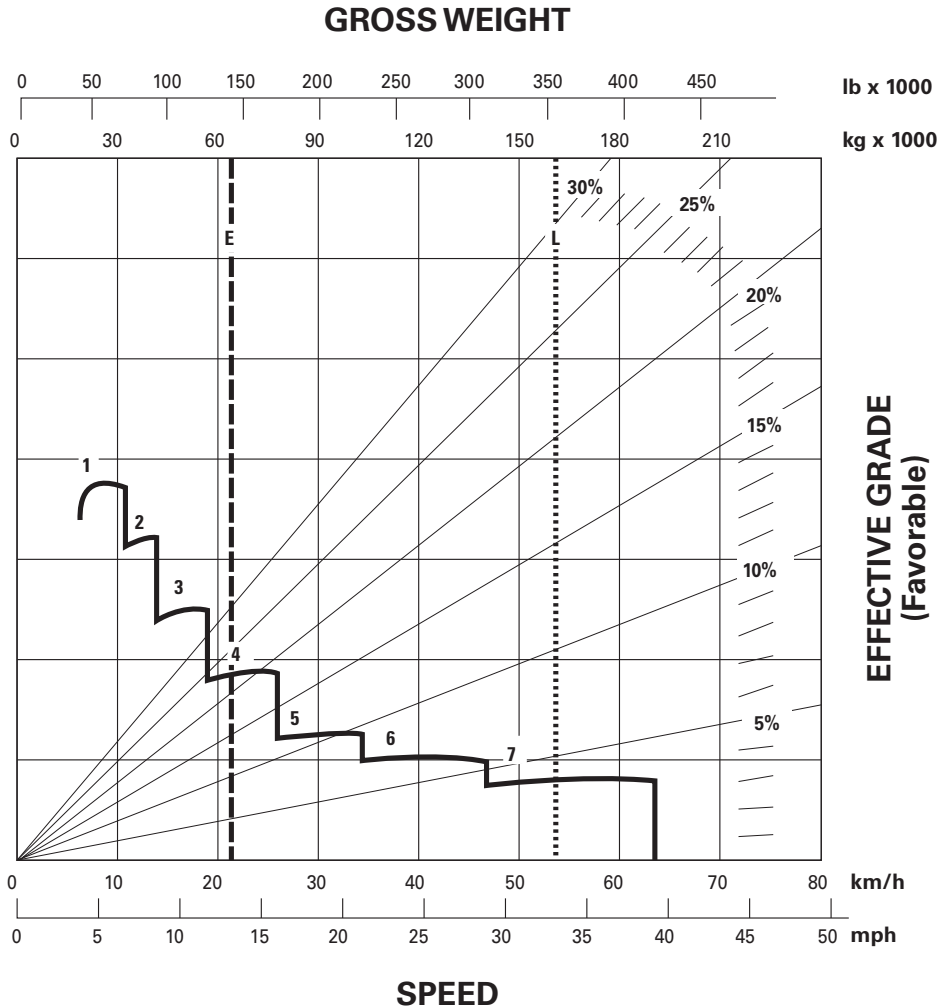

CONTINUOUS GRADE LENGTH

KEY

- 1 – 1st Gear
- 2 – 2nd Gear
- 3 – 3rd Gear
- 4 – 4th Gear
- 5 – 5th Gear
- 6 – 6th Gear
- 7 – 7th Gear

KEY

- E – Empty 64 359 kg (141,889 lb)
- L – Max GMW 163 360 kg (360,143 lb)

777D Brake Performance

- 450 m (1500 ft)
- 600 m (2000 ft)
- 900 m (3000 ft)
- 1500 m (5000 ft)

Mining & Off-Highway Trucks

GROSS WEIGHT

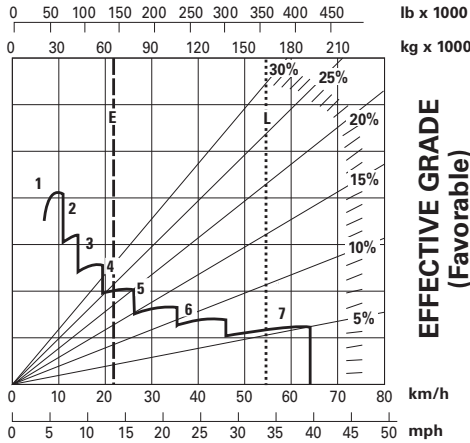

SPEED
GRADE DISTANCE — 450 m (1500 ft)

GROSS WEIGHT

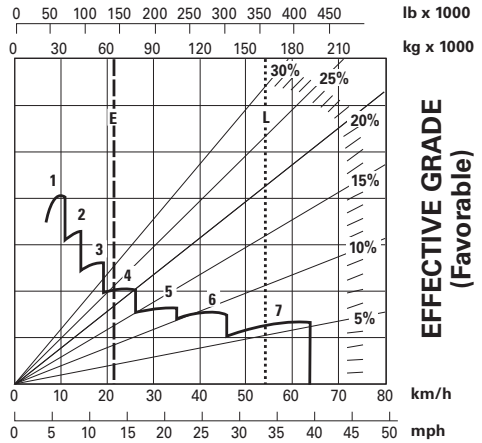

SPEED
GRADE DISTANCE — 600 m (2000 ft)

GROSS WEIGHT

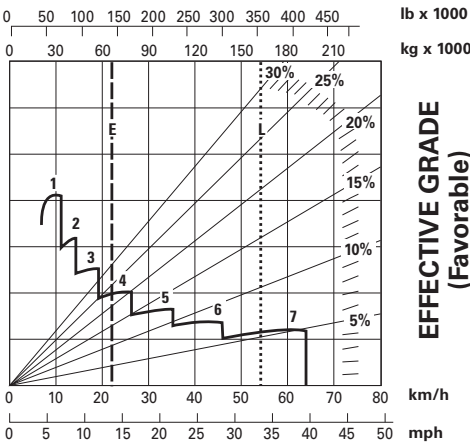

SPEED
GRADE DISTANCE — 900 m (3000 ft)

GROSS WEIGHT

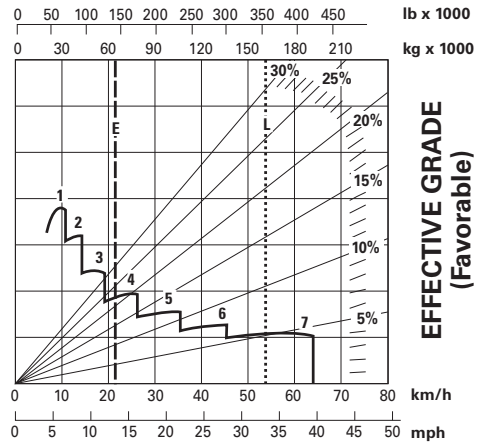

SPEED
GRADE DISTANCE — 1500 m (5000 ft)

KEY

- 1 — 1st Gear
- 2 — 2nd Gear
- 3 — 3rd Gear
- 4 — 4th Gear
- 5 — 5th Gear
- 6 — 6th Gear
- 7 — 7th Gear

KEY

- E — Empty 64 359 kg (141,889 lb)
- L — Max GMW 163 360 kg (360,143 lb)

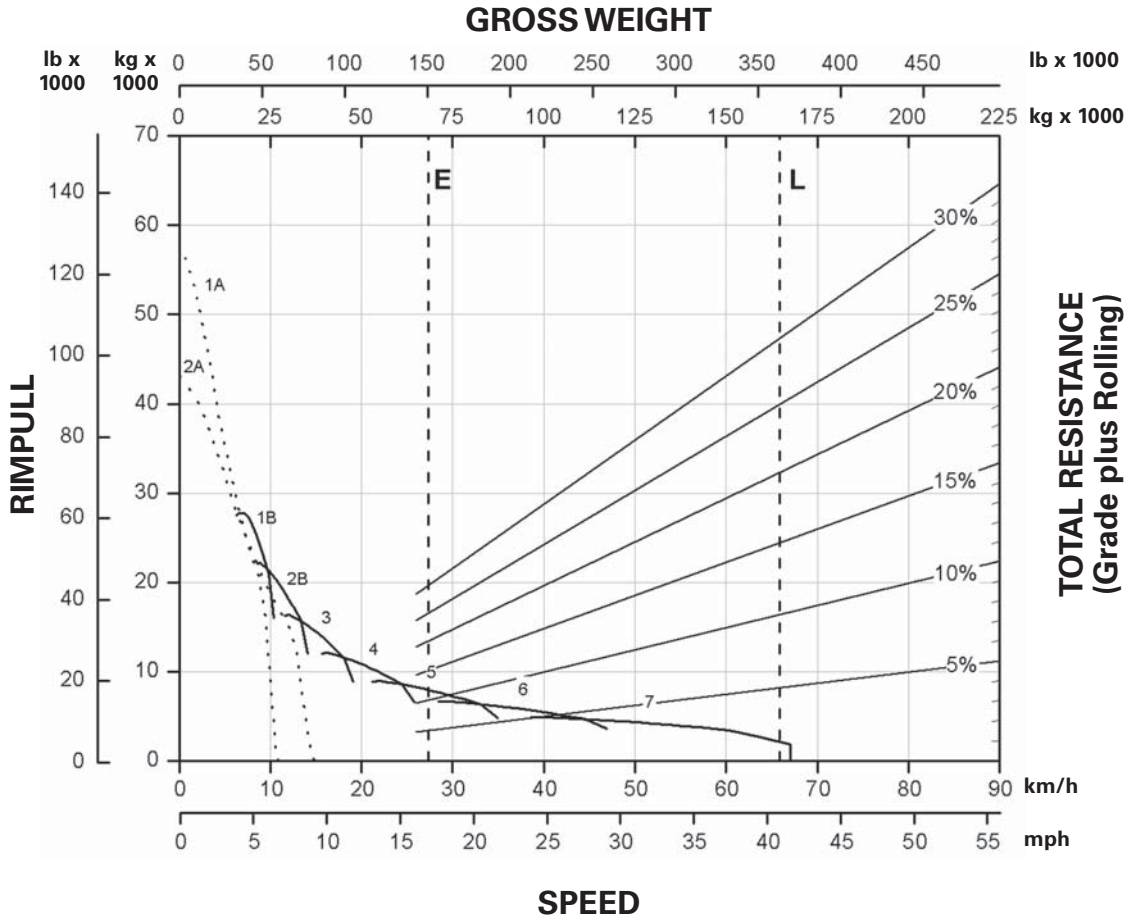

KEY

- 1A — 1st Gear (Torque Converter)
- 1B — 1st Gear
- 2A — 2nd Gear (Torque Converter)
- 2B — 2nd Gear
- 3 — 3rd Gear
- 4 — 4th Gear
- 5 — 5th Gear
- 6 — 6th Gear
- 7 — 7th Gear

KEY

- E — Empty 68 315 kg (150,609 lb)
- L — Target GMW 164 654 kg (363,000 lb)

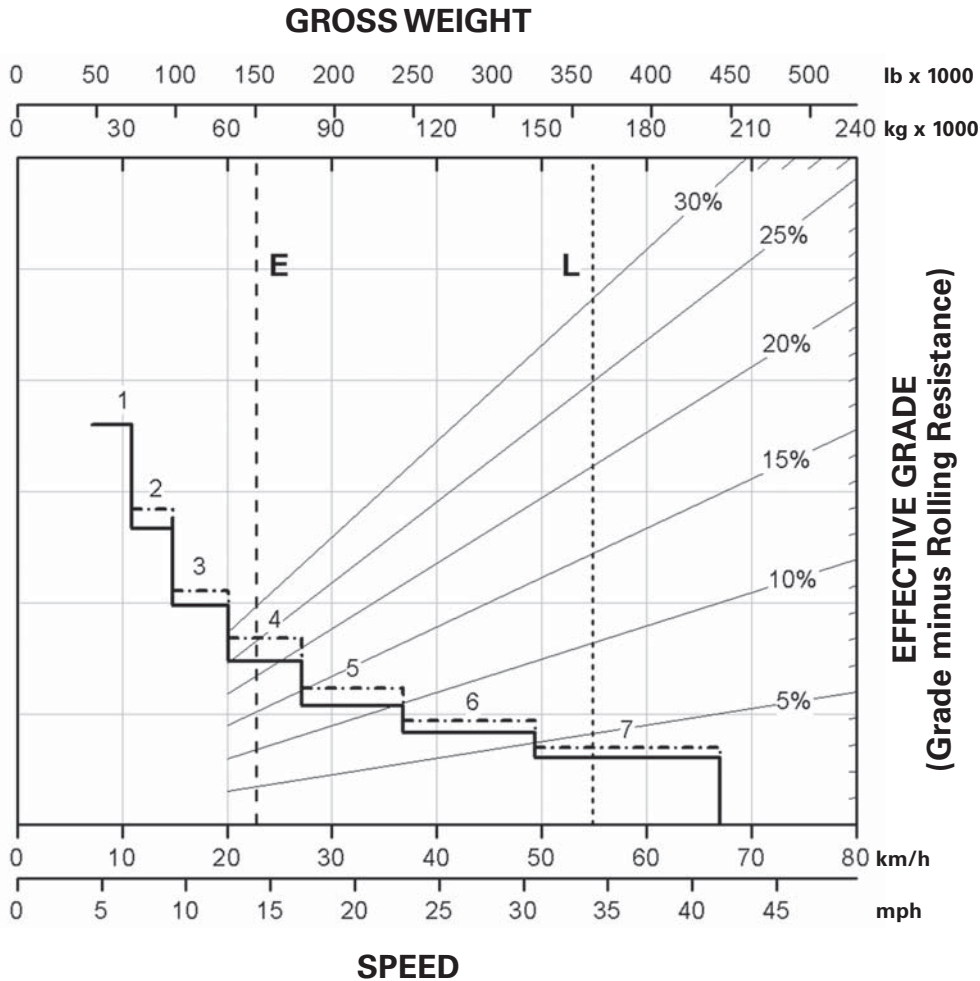

CONTINUOUS GRADE LENGTH

KEY

- 1 — 1st Gear
- 2 — 2nd Gear
- 3 — 3rd Gear
- 4 — 4th Gear
- 5 — 5th Gear
- 6 — 6th Gear
- 7 — 7th Gear

KEY

- E — Empty 68 315 kg (150,609 lb)
- L — Target GMW 164 654 kg (363,000 lb)
- With ARC Only
- - - - - ARC and Engine Brake

Mining & Off-Highway Trucks

777G Tier 4 Final Brake Performance

- 450 m (1500 ft)
- 600 m (2000 ft)
- 900 m (3000 ft)
- 1500 m (5000 ft)

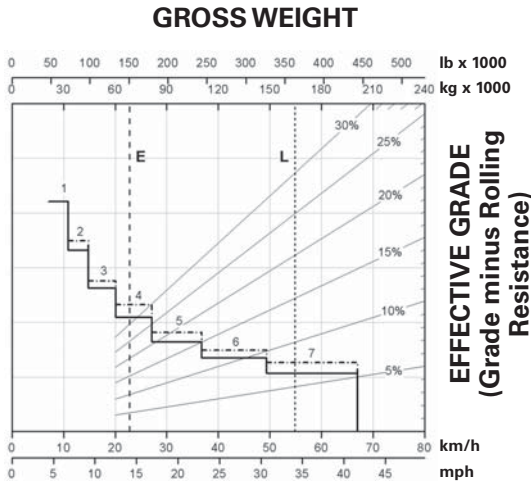

SPEED
GRADE DISTANCE — 450 m (1500 ft)

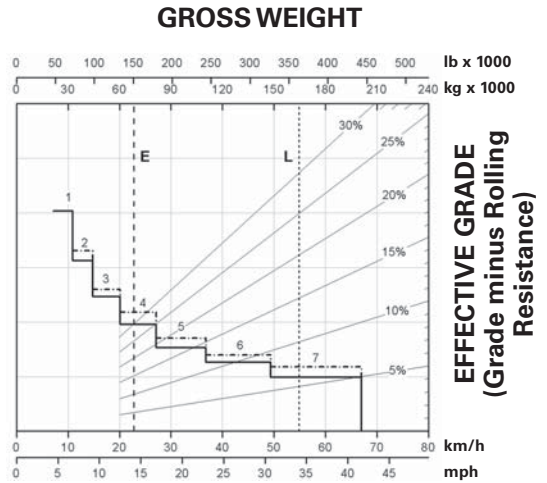

SPEED
GRADE DISTANCE — 600 m (2000 ft)

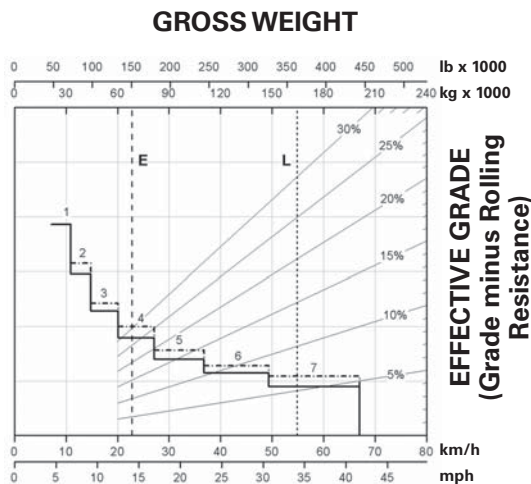

SPEED
GRADE DISTANCE — 900 m (3000 ft)

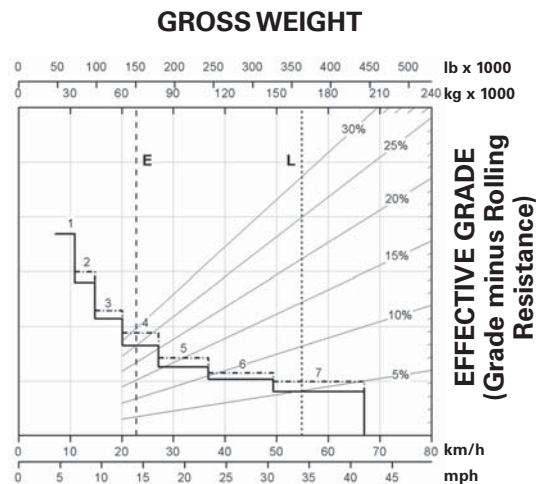

SPEED
GRADE DISTANCE — 1500 m (5000 ft)

KEY

- 1 — 1st Gear
- 2 — 2nd Gear
- 3 — 3rd Gear
- 4 — 4th Gear
- 5 — 5th Gear
- 6 — 6th Gear
- 7 — 7th Gear

KEY

- E — Empty 68 315 kg (150,609 lb)
- L — Target GMW 164 654 kg (363,000 lb)
- With ARC Only
- ARC and Engine Brake

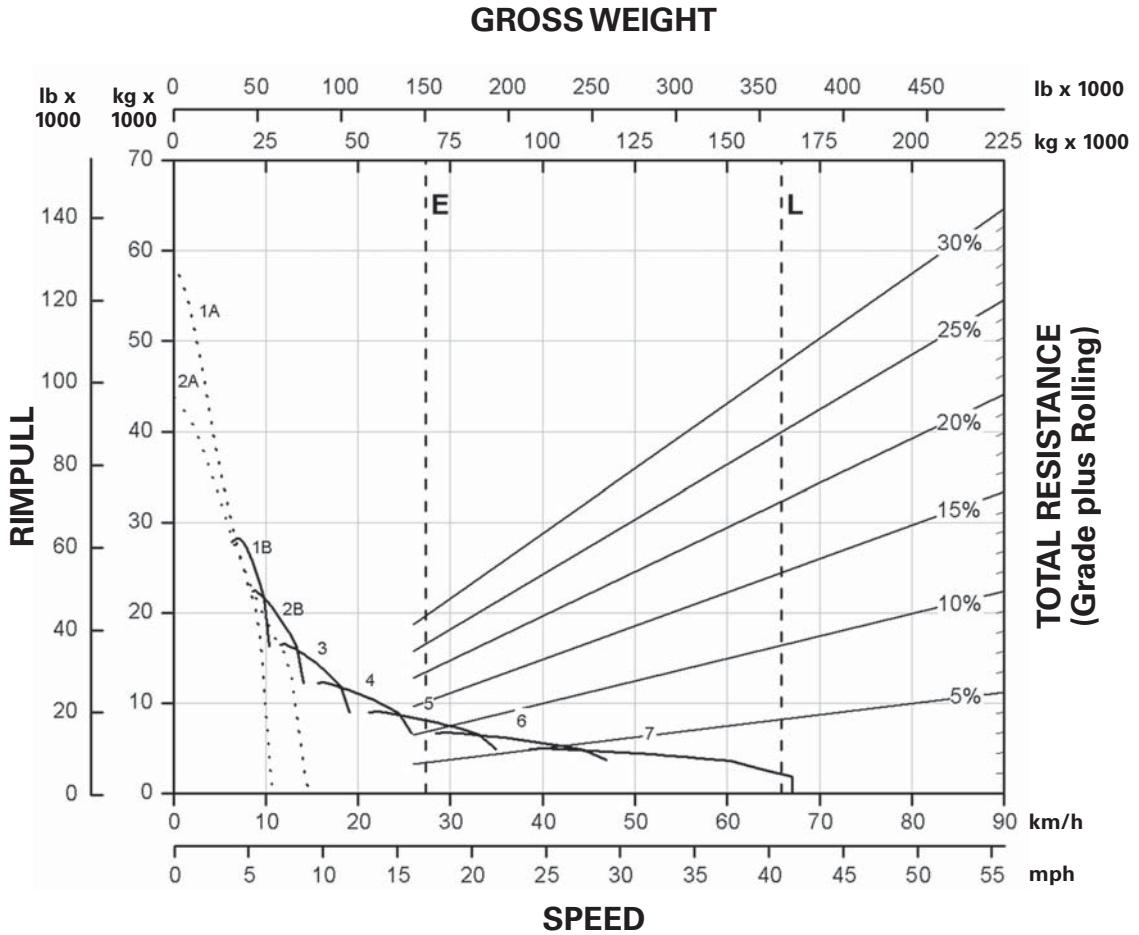

KEY

- 1A — 1st Gear (Torque Converter)
- 1B — 1st Gear
- 2A — 2nd Gear (Torque Converter)
- 2B — 2nd Gear
- 3 — 3rd Gear
- 4 — 4th Gear
- 5 — 5th Gear
- 6 — 6th Gear
- 7 — 7th Gear

KEY

- E — Empty 67 923 kg (149,744 lb)
- L — Target GMW 164 654 kg (363,000 lb)

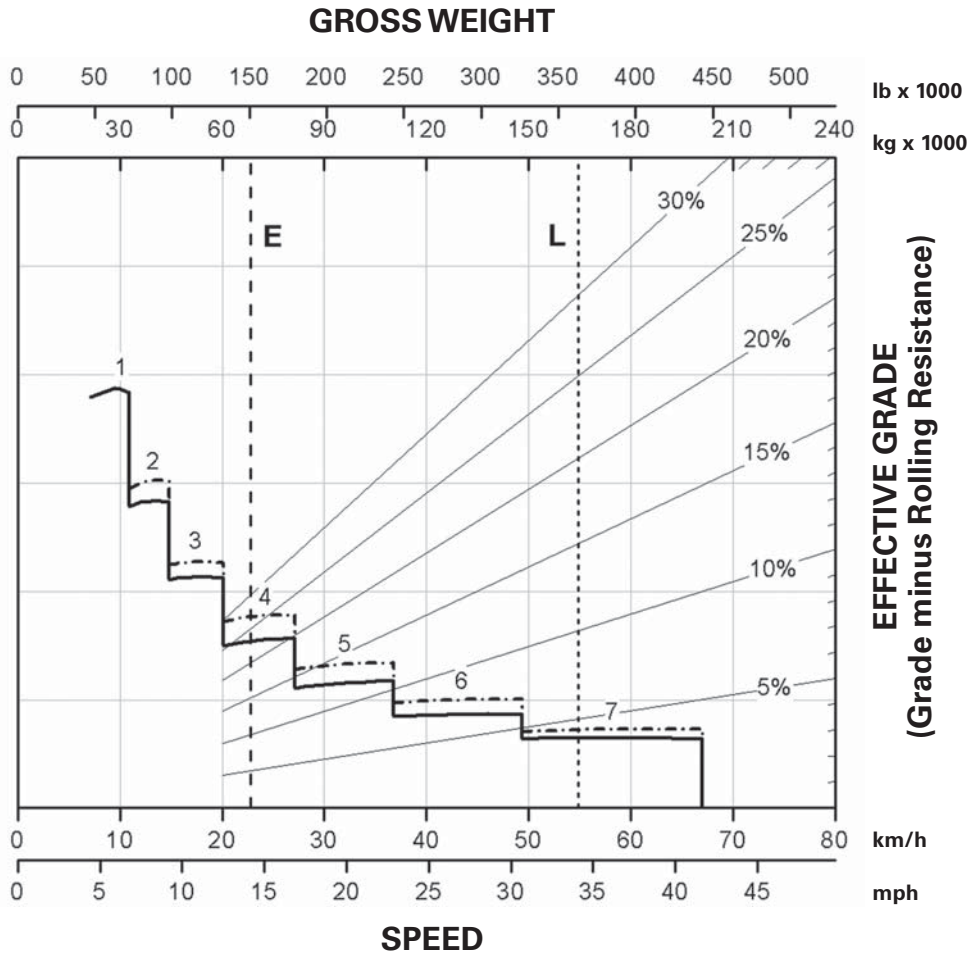

KEY

- 1 — 1st Gear
- 2 — 2nd Gear
- 3 — 3rd Gear
- 4 — 4th Gear
- 5 — 5th Gear
- 6 — 6th Gear
- 7 — 7th Gear

KEY

- E — Empty 67 923 kg (149,744 lb)
- L — Target GMW 164 654 kg (363,000 lb)
- With ARC Only
- - - - - ARC and Engine Brake

777G Brake Performance

- 450 m (1500 ft)
- 600 m (2000 ft)
- 900 m (3000 ft)
- 1500 m (5000 ft)

Mining & Off-Highway Trucks

GROSS WEIGHT

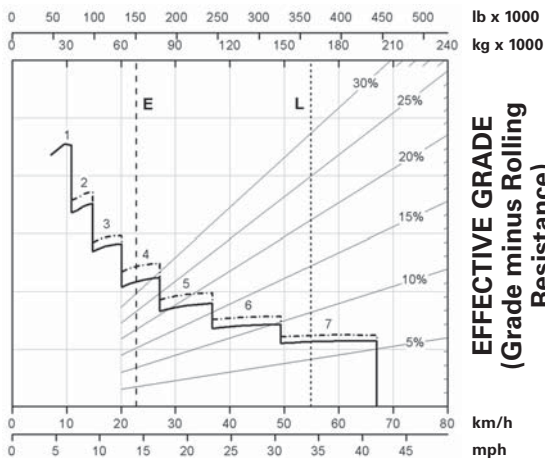

SPEED
GRADE DISTANCE — 450 m (1500 ft)

GROSS WEIGHT

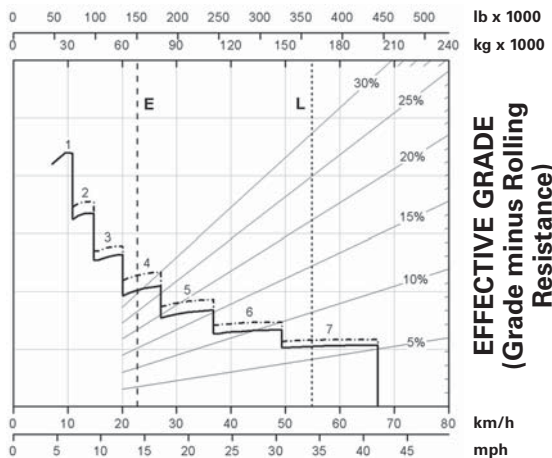

SPEED
GRADE DISTANCE — 600 m (2000 ft)

GROSS WEIGHT

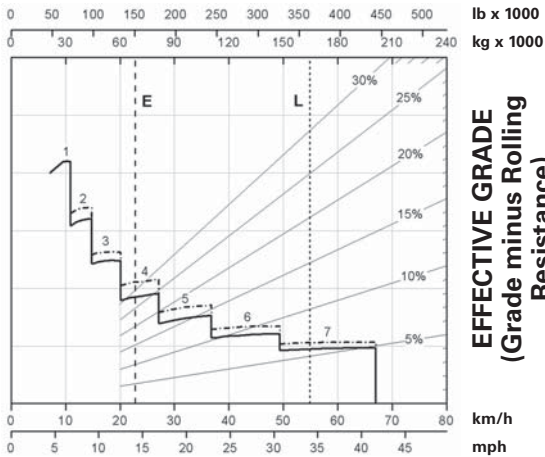

SPEED
GRADE DISTANCE — 900 m (3000 ft)

GROSS WEIGHT

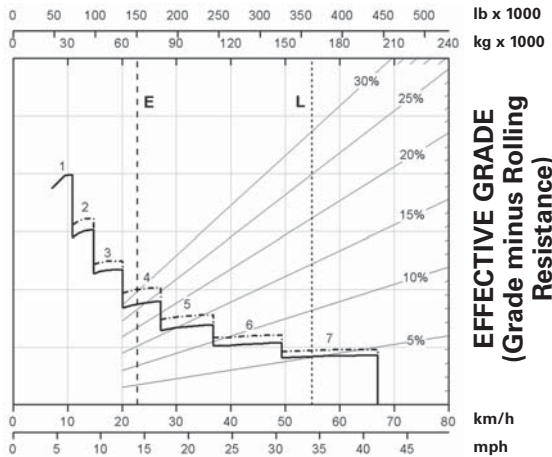

SPEED
GRADE DISTANCE — 1500 m (5000 ft)

KEY

- 1 — 1st Gear
- 2 — 2nd Gear
- 3 — 3rd Gear
- 4 — 4th Gear
- 5 — 5th Gear
- 6 — 6th Gear
- 7 — 7th Gear

KEY

- E — Empty 67 923 kg (149,744 lb)
- L — Target GMW 164 654 kg (363,000 lb)
- With ARC Only
- - - - - ARC and Engine Brake

Mining & Off-Highway Trucks

785C Rimpull-Speed-Gradeability

- 33.00R51 Tires*
- 1433 mm (4'4.4") Tire Radius

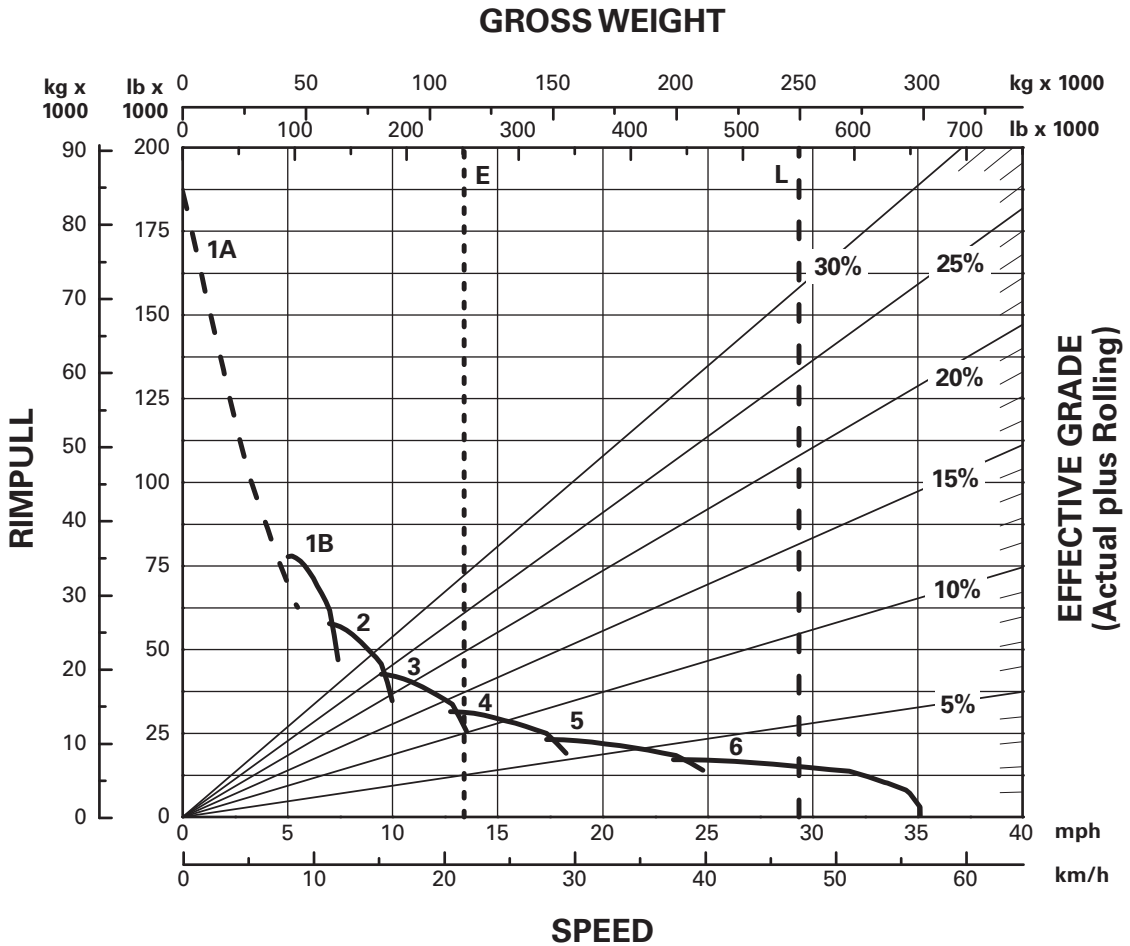

KEY

- 1A – 1st Gear (Torque Converter)
- 1B – 1st Gear
- 2 – 2nd Gear
- 3 – 3rd Gear
- 4 – 4th Gear
- 5 – 5th Gear
- 6 – 6th Gear

KEY

- E – Empty Operating Weight 115 460 kg (254,546 lb)
- L – Target GMW 249 476 kg (550,000 lb)

*At Sea Level.

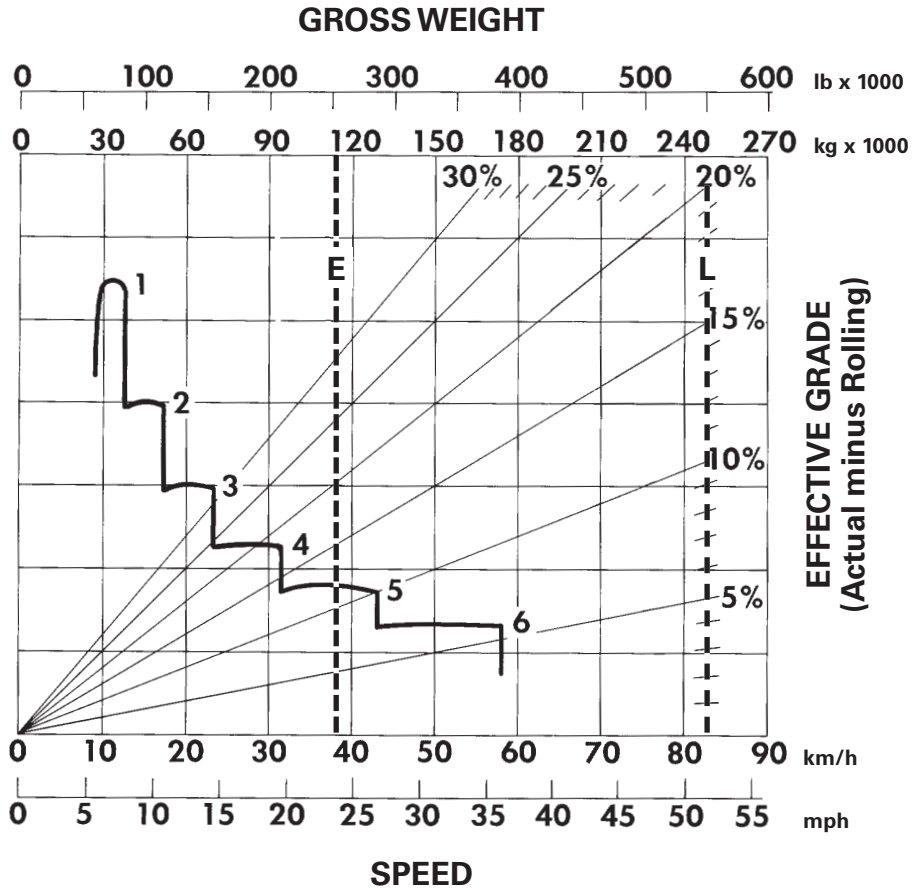

CONTINUOUS GRADE LENGTH

KEY

- 1 — 1st Gear
- 2 — 2nd Gear
- 3 — 3rd Gear
- 4 — 4th Gear
- 5 — 5th Gear
- 6 — 6th Gear

KEY

- E — Empty Operating Weight 115 460 kg (254,546 lb)
- L — Target GMW 249 476 kg (550,000 lb)

Mining & Off-Highway Trucks

785C Brake Performance

- 450 m (1500 ft)
- 600 m (2000 ft)
- 900 m (3000 ft)
- 1500 m (5000 ft)

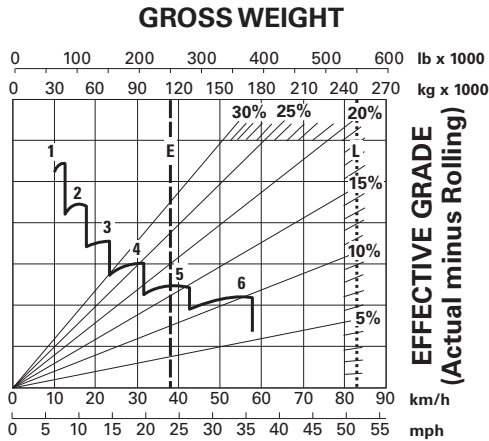

GRADE DISTANCE — 450 m (1500 ft)

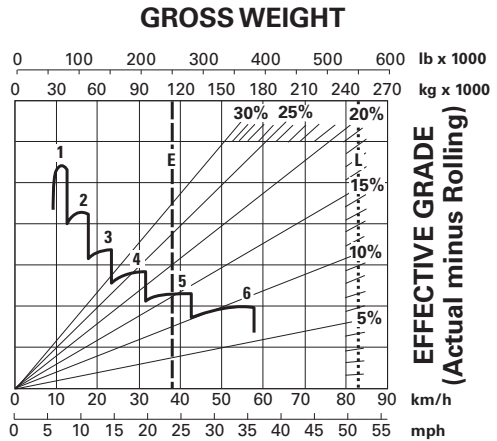

GRADE DISTANCE — 600 m (2000 ft)

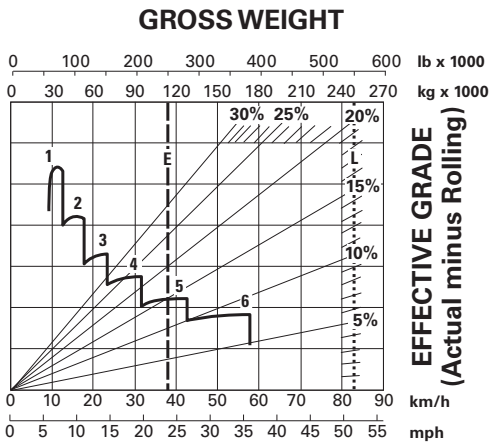

GRADE DISTANCE — 900 m (3000 ft)

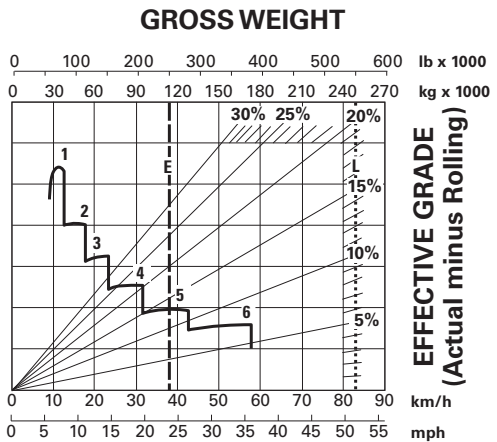

GRADE DISTANCE — 1500 m (5000 ft)

KEY

- 1 — 1st Gear
- 2 — 2nd Gear
- 3 — 3rd Gear
- 4 — 4th Gear
- 5 — 5th Gear
- 6 — 6th Gear

KEY

- E — Empty Operating Weight 115 460 kg (254,546 lb)
- L — Target GMW 249 476 kg (550,000 lb)

785D Rimpull-Speed-Gradeability

● 33.00R51 Tires*

● 1433 mm (4'8.4") Tire Radius

Mining & Off-Highway Trucks

GROSS WEIGHT

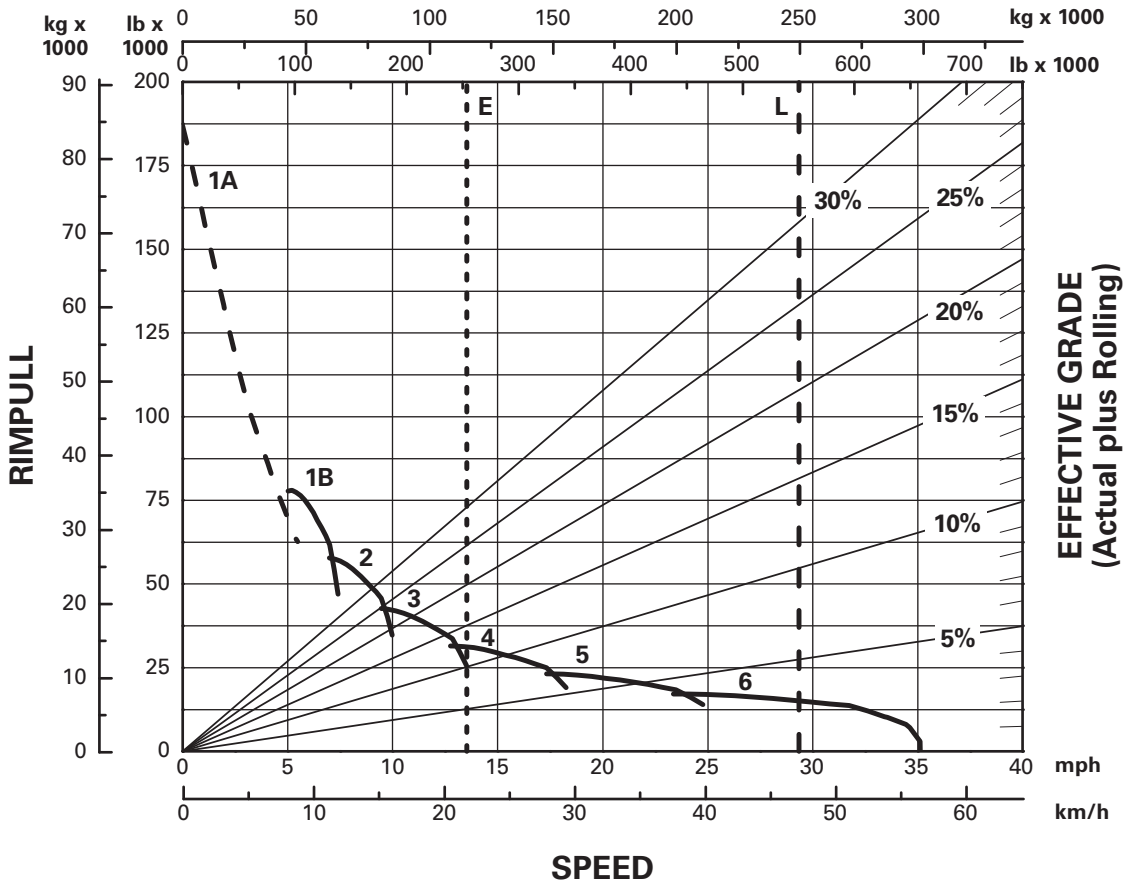

KEY

- 1A – 1st Gear (Torque Converter)
- 1B – 1st Gear
- 2 – 2nd Gear
- 3 – 3rd Gear
- 4 – 4th Gear
- 5 – 5th Gear
- 6 – 6th Gear

KEY

- E – Empty Operating Weight 116 525 kg (256,894 lb)
- L – Target GMW 249 476 kg (550,000 lb)

*At Sea Level.

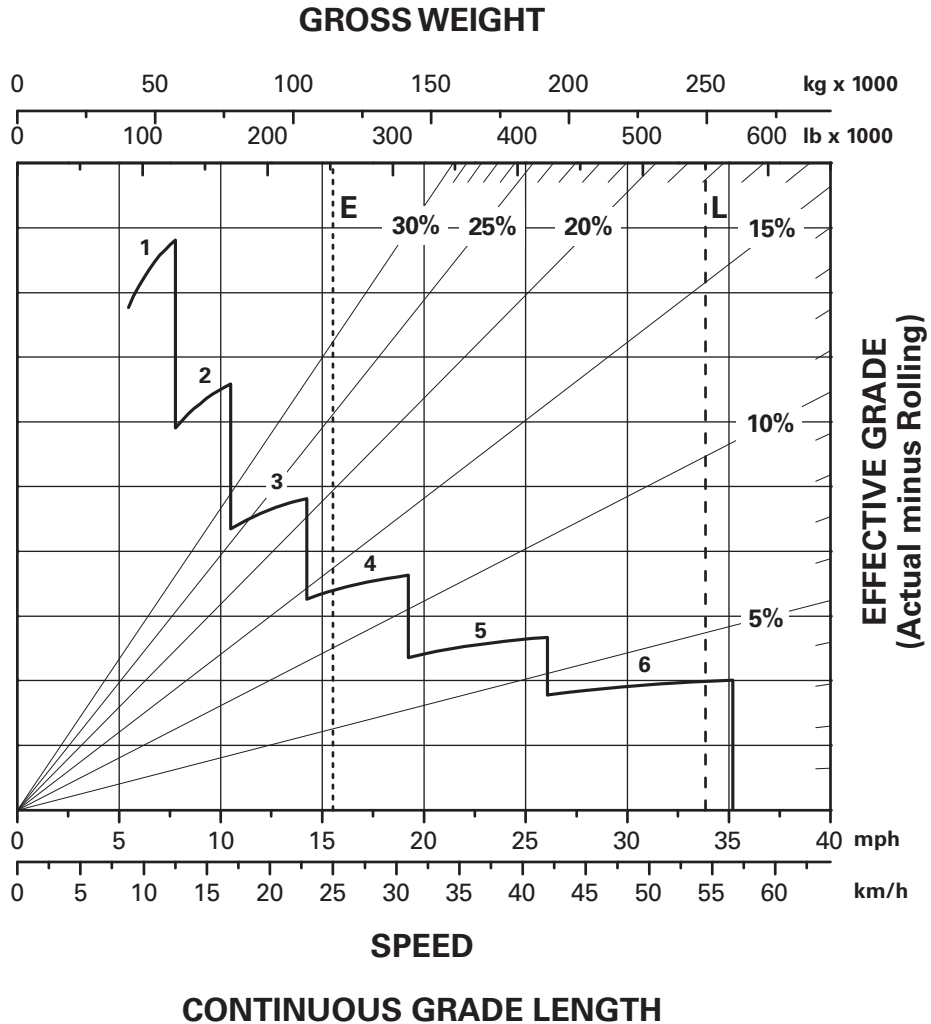

KEY

- 1 — 1st Gear
- 2 — 2nd Gear
- 3 — 3rd Gear
- 4 — 4th Gear
- 5 — 5th Gear
- 6 — 6th Gear

KEY

- E — Empty Operating Weight 116 525 kg (256,894 lb)
- L — Target GMW 249 476 kg (550,000 lb)

*At Sea Level.

785D Brake Performance

- 450 m (1500 ft)
- 600 m (2000 ft)
- 900 m (3000 ft)
- 1500 m (5000 ft)

Mining & Off-Highway Trucks

GROSS WEIGHT

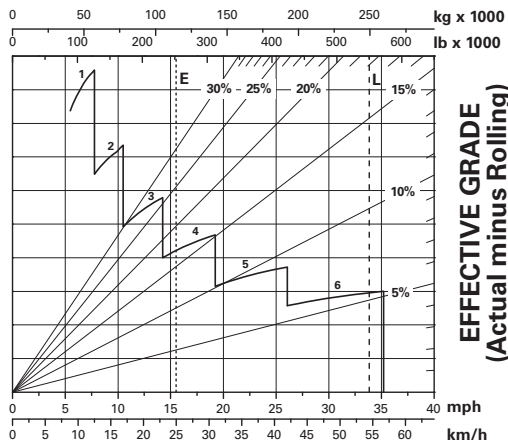

SPEED

GRADE DISTANCE — 450 m (1500 ft)*

GROSS WEIGHT

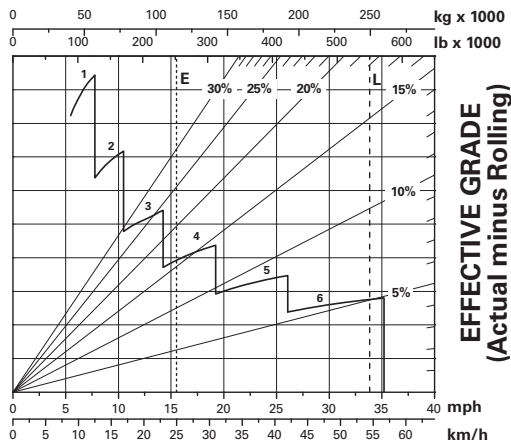

SPEED

GRADE DISTANCE — 600 m (2000 ft)*

GROSS WEIGHT

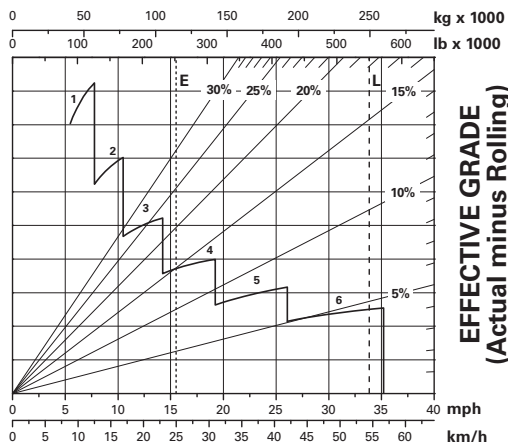

SPEED

GRADE DISTANCE — 900 m (3000 ft)*

GROSS WEIGHT

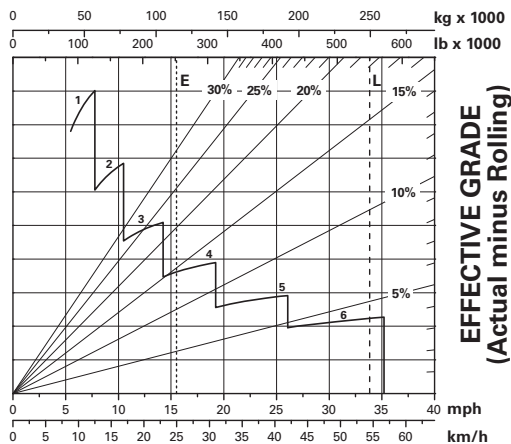

SPEED

GRADE DISTANCE — 1500 m (5000 ft)*

KEY

- 1 — 1st Gear
- 2 — 2nd Gear
- 3 — 3rd Gear
- 4 — 4th Gear
- 5 — 5th Gear
- 6 — 6th Gear

KEY

- E — Empty Operating Weight 116 525 kg (256,894 lb)
- L — Target GMW 249 476 kg (550,000 lb)

*At Sea Level.

Mining & Off-Highway Trucks

789D 2100 HP Rimpull-Speed-Gradeability

- 37.00R57 Tires**
- 1593 mm (5'2.7") Tire Radius

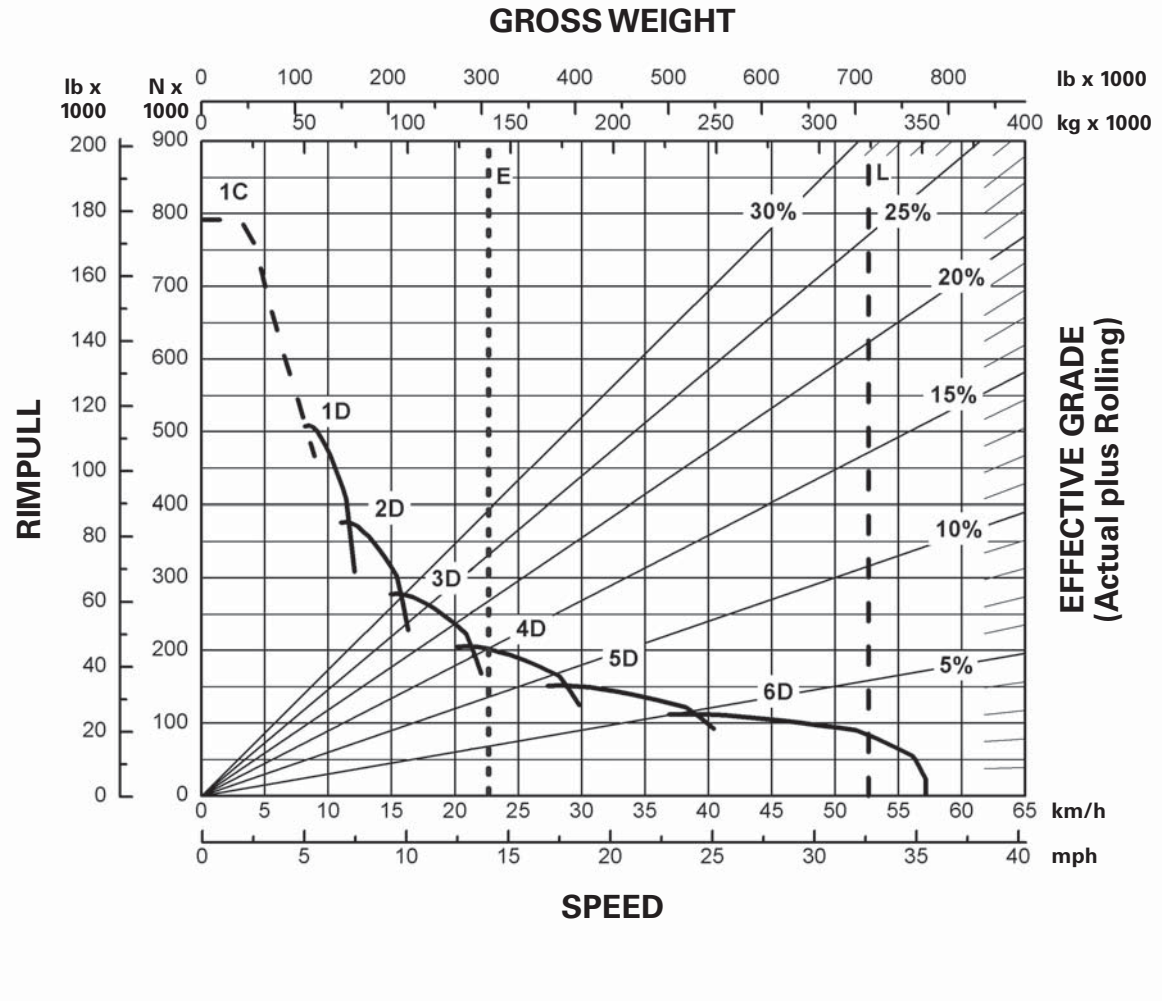

KEY

- 1C — 1st Gear (Torque Converter)
- 1D — 1st Gear
- 2D — 2nd Gear
- 3D — 3rd Gear
- 4D — 4th Gear
- 5D — 5th Gear
- 6D — 6th Gear

KEY

- E — Empty Operating Weight 141 214 kg (311,324 lb)*
- L — Target GMW 324 319 kg (715,000 lb)

*Truck equipped with sideboards and liners.
 **At Sea Level.

789D 1900 HP Rimpull-Speed-Gradeability

Mining & Off-Highway Trucks

- 37.00R57 Tires**
- 1593 mm (5'2.7") Tire Radius

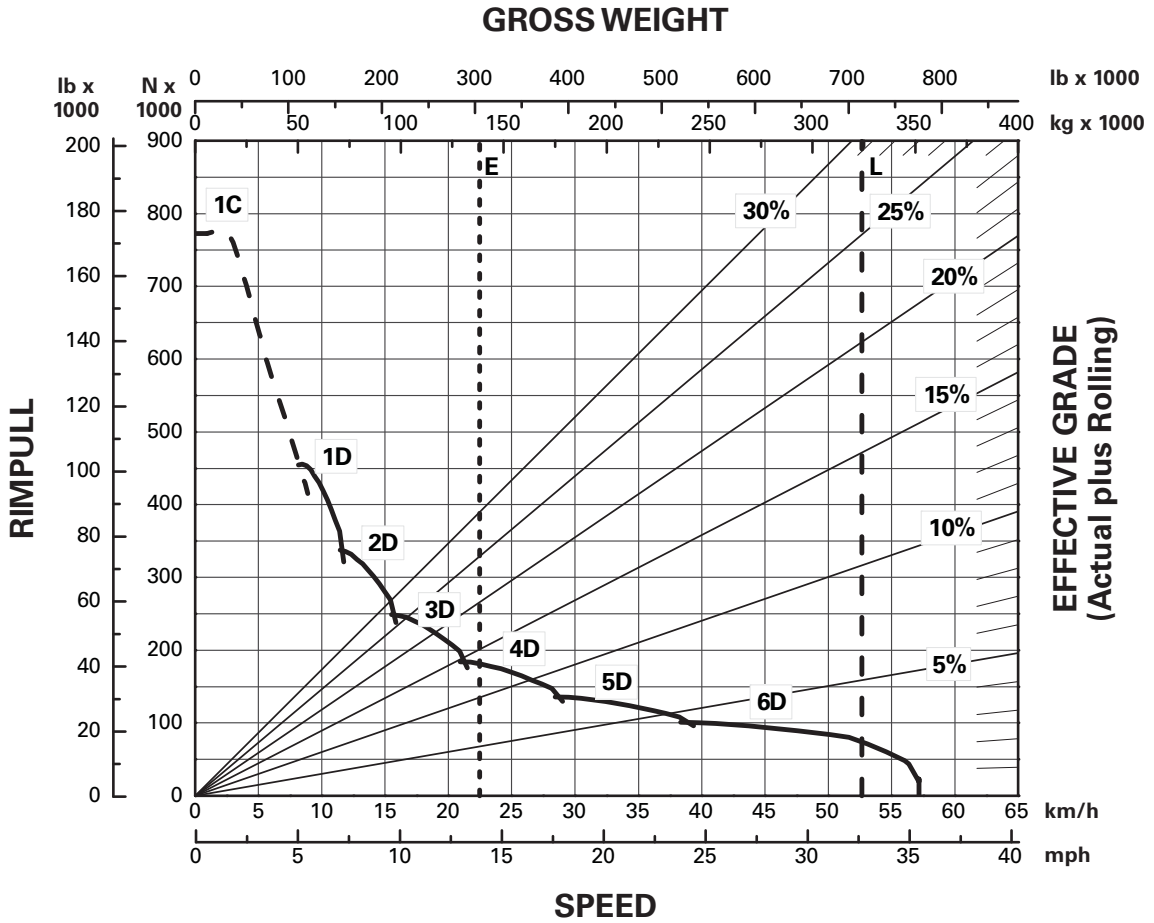

KEY

- 1C — 1st Gear (Torque Converter)
- 1D — 1st Gear
- 2D — 2nd Gear
- 3D — 3rd Gear
- 4D — 4th Gear
- 5D — 5th Gear
- 6D — 6th Gear

KEY

- E — Empty Operating Weight 141 214 kg (311,324 lb)*
- L — Target GMW 324 319 kg (715,000 lb)

*Truck equipped with sideboards and liners.
 **At Sea Level.

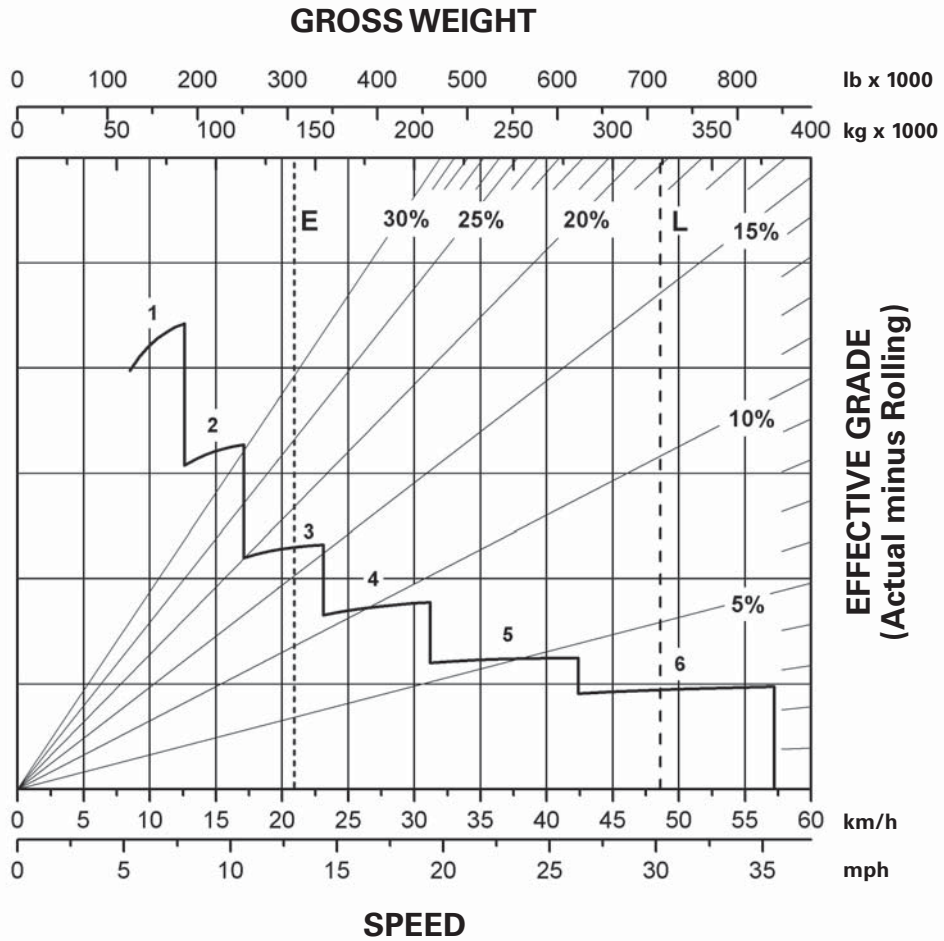

KEY

- 1 — 1st Gear
- 2 — 2nd Gear
- 3 — 3rd Gear
- 4 — 4th Gear
- 5 — 5th Gear
- 6 — 6th Gear

KEY

- E — Empty Operating Weight 141 214 kg (311,324 lb)*
- L — Target GMW 324 319 kg (715,000 lb)

*Truck equipped with sideboards and liners.
 **At Sea Level.

789D Brake Performance

- 450 m (1500 ft)
- 600 m (2000 ft)
- 900 m (3000 ft)
- 1500 m (5000 ft)

Mining & Off-Highway Trucks

GROSS WEIGHT

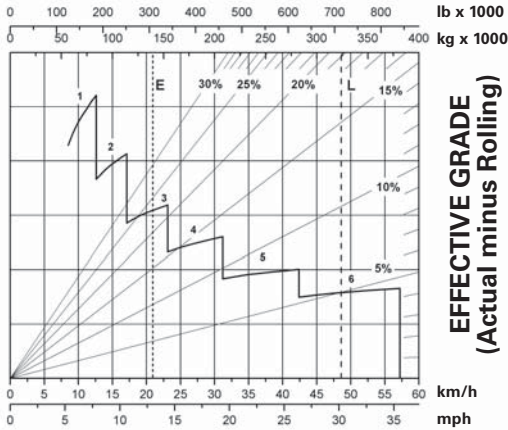

SPEED

GRADE DISTANCE — 450 m (1500 ft)**

GROSS WEIGHT

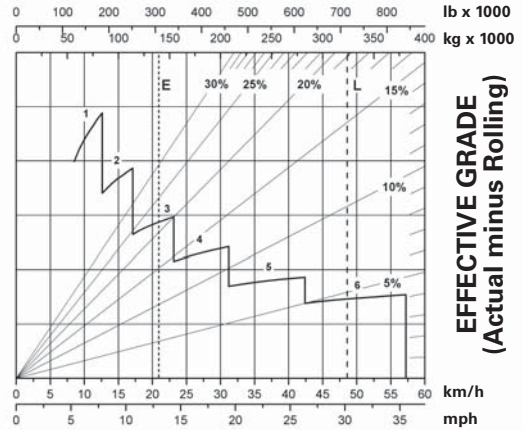

SPEED

GRADE DISTANCE — 600 m (2000 ft)**

GROSS WEIGHT

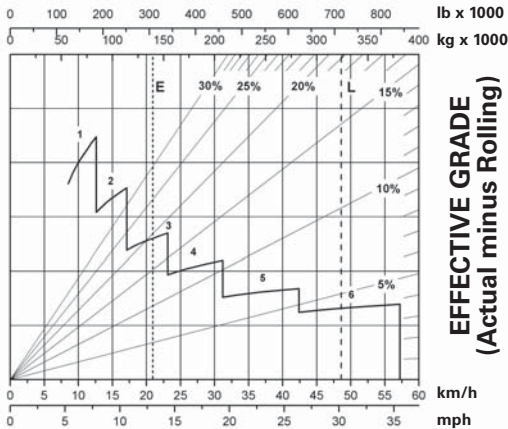

SPEED

GRADE DISTANCE — 900 m (3000 ft)**

GROSS WEIGHT

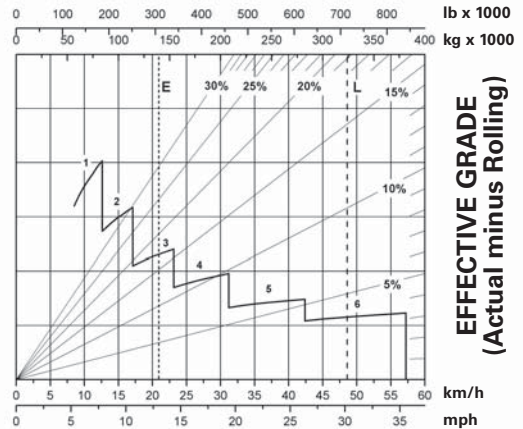

SPEED

GRADE DISTANCE — 1500 m (5000 ft)**

KEY

- 1 — 1st Gear
- 2 — 2nd Gear
- 3 — 3rd Gear
- 4 — 4th Gear
- 5 — 5th Gear
- 6 — 6th Gear

KEY

- E — Empty Operating Weight 141 214 kg (311,324 lb)*
- L — Target GMW 324 319 kg (715,000 lb)

*Truck equipped with sideboards and liners.
**At Sea Level.

Mining & Off-Highway Trucks

793D Rimpull-Speed-Gradeability

- Standard Arrangement*
- 40.00R57 Tires
- 1778 mm (5'10") Tire Radius

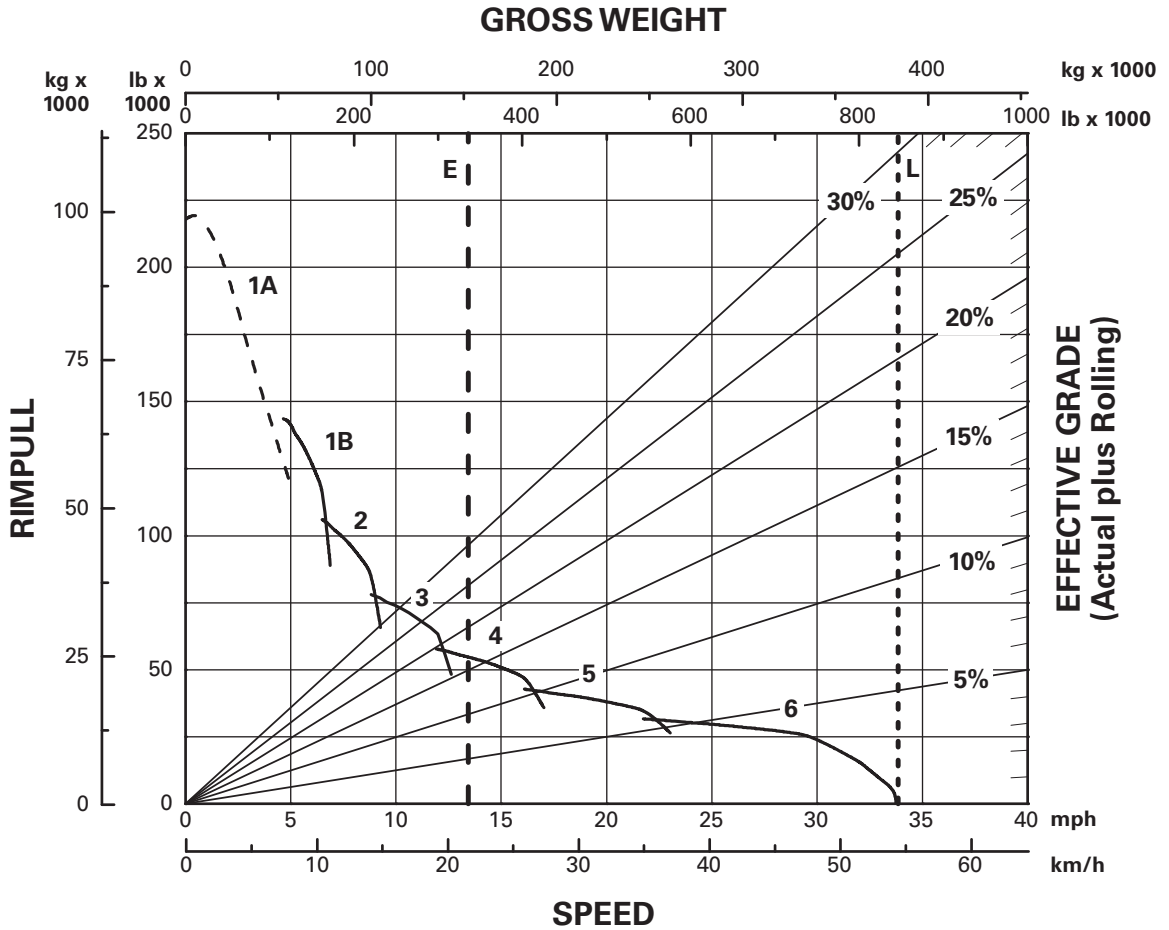

KEY

- 1A — 1st Gear (Torque Converter)
- 1B — 1st Gear
- 2 — 2nd Gear
- 3 — 3rd Gear
- 4 — 4th Gear
- 5 — 5th Gear
- 6 — 6th Gear

KEY

- E — Empty Operating Weight 154 729 kg (341,119 lb)
- L — Target GMW 383 740 kg (846,000 lb)

*At Sea Level.

- 793D Brake Performance
- Standard Arrangement*
 - Continuous Grade Retarding

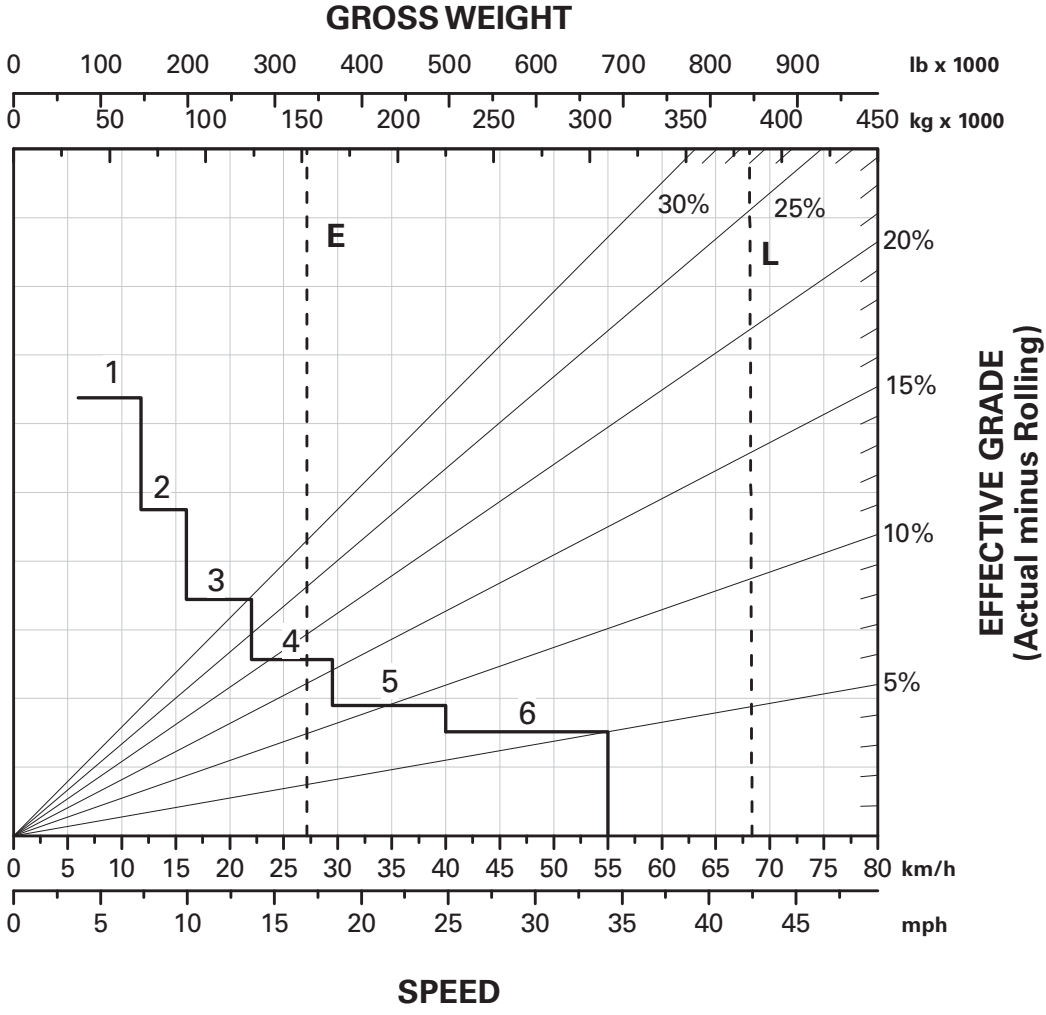

CONTINUOUS GRADE LENGTH

- KEY**
- 1 — 1st Gear
 - 2 — 2nd Gear
 - 3 — 3rd Gear
 - 4 — 4th Gear
 - 5 — 5th Gear
 - 6 — 6th Gear

- KEY**
- E — Empty Operating Weight 154 729 kg (341,119 lb)
 - L — Target GMW 383 740 kg (846,000 lb)

*At Sea Level.

Mining & Off-Highway Trucks

793D Brake Performance

● Standard Arrangement*

● 450 m (1500 ft) ● 600 m (2000 ft)

● 900 m (3000 ft) ● 1500 m (5000 ft)

GROSS WEIGHT

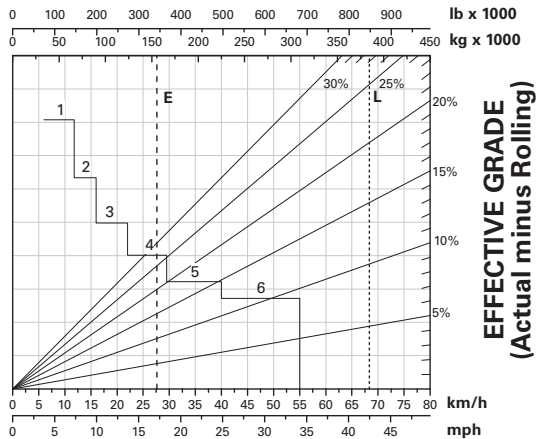

SPEED

GRADE DISTANCE — 450 m (1500 ft)

GROSS WEIGHT

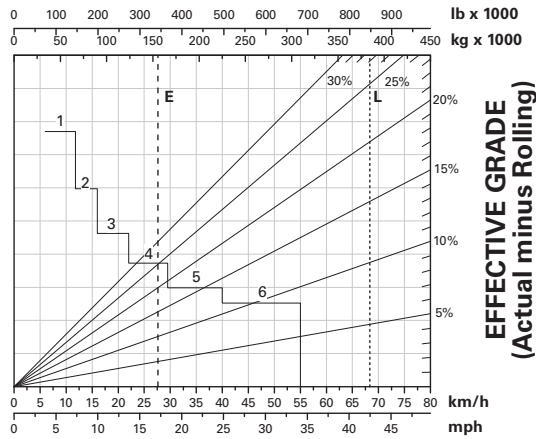

SPEED

GRADE DISTANCE — 600 m (2000 ft)

GROSS WEIGHT

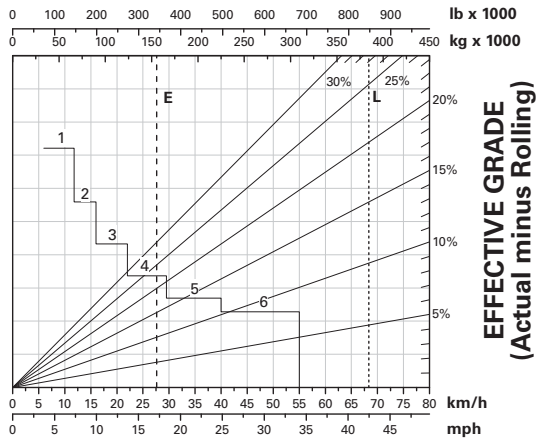

SPEED

GRADE DISTANCE — 900 m (3000 ft)

GROSS WEIGHT

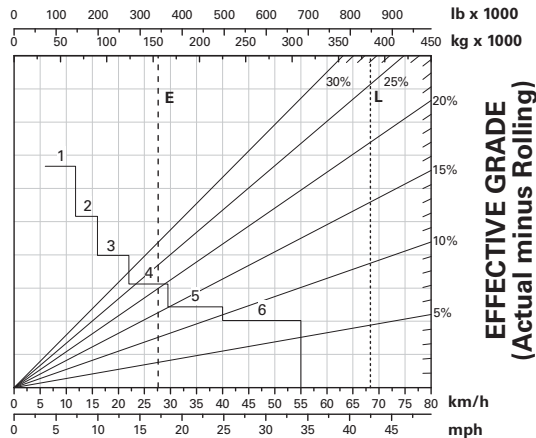

SPEED

GRADE DISTANCE — 1500 m (5000 ft)

KEY

- 1 — 1st Gear
- 2 — 2nd Gear
- 3 — 3rd Gear
- 4 — 4th Gear
- 5 — 5th Gear
- 6 — 6th Gear

KEY

- E — Empty Operating Weight 154 729 kg (341,119 lb)
- L — Target GMW 383 740 kg (846,000 lb)

*At Sea Level.

- 793D Brake Performance
- Additional Retarding Arrangement*
- Continuous Grade Retarding

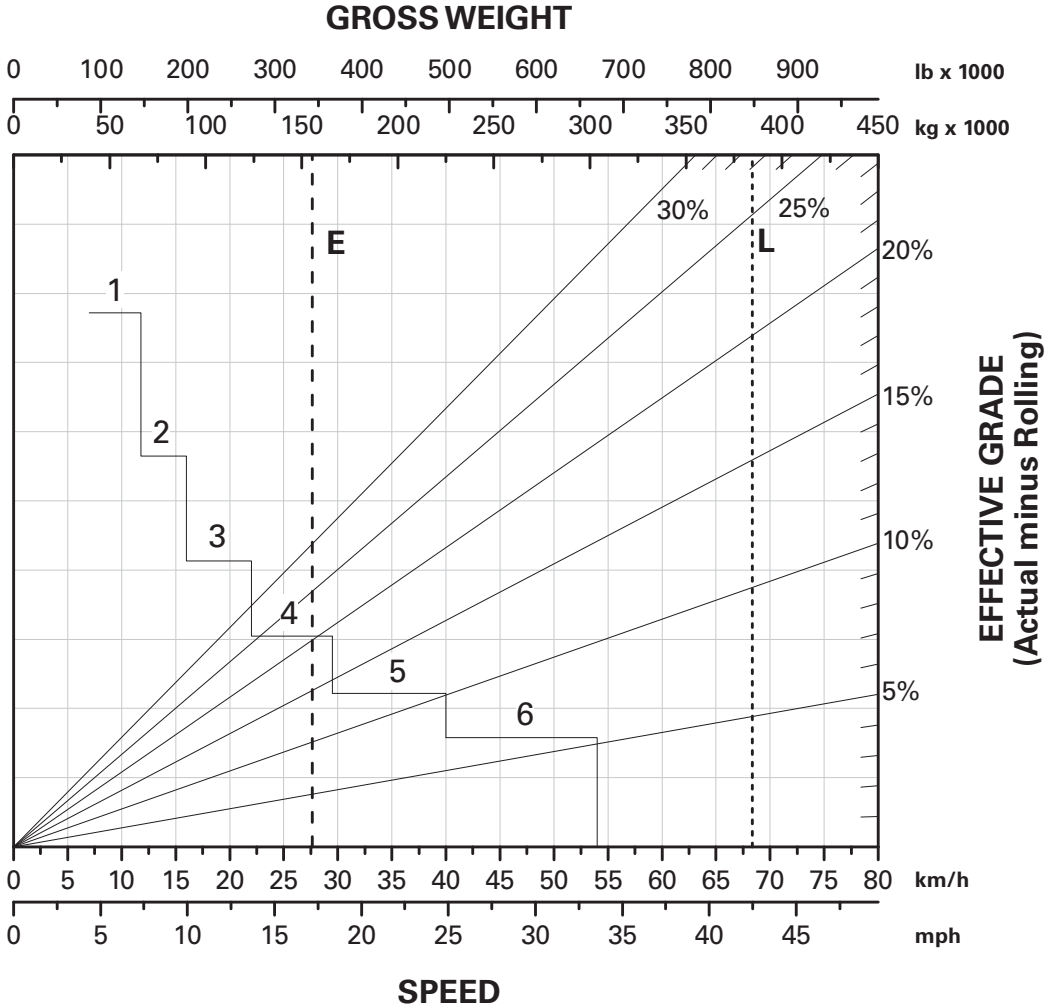

- KEY**
- 1 — 1st Gear
 - 2 — 2nd Gear
 - 3 — 3rd Gear
 - 4 — 4th Gear
 - 5 — 5th Gear
 - 6 — 6th Gear

- KEY**
- E — Empty Operating Weight 154 729 kg (341,119 lb)
 - L — Target GMW 383 740 kg (846,000 lb)

*At Sea Level.

Mining & Off-Highway Trucks

793D Brake Performance

- Additional Retarding Arrangement*
- 450 m (1500 ft) ● 600 m (2000 ft)
- 900 m (3000 ft) ● 1500 m (5000 ft)

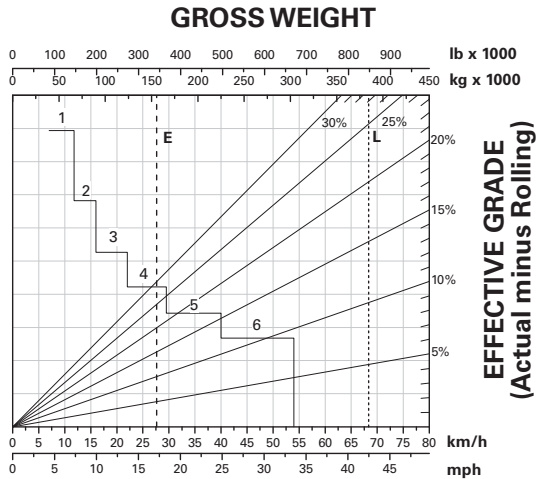

GRADE DISTANCE — 450 m (1500 ft)

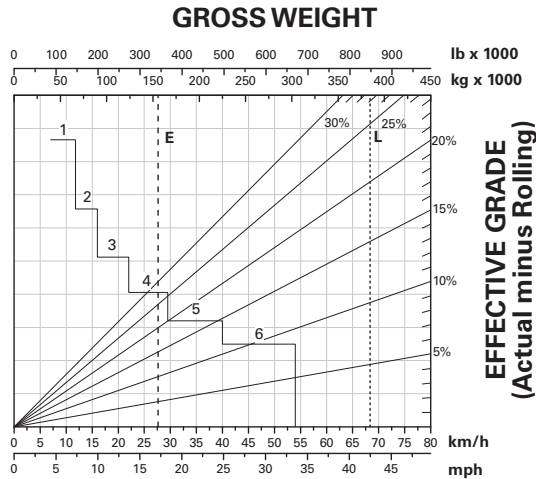

GRADE DISTANCE — 600 m (2000 ft)

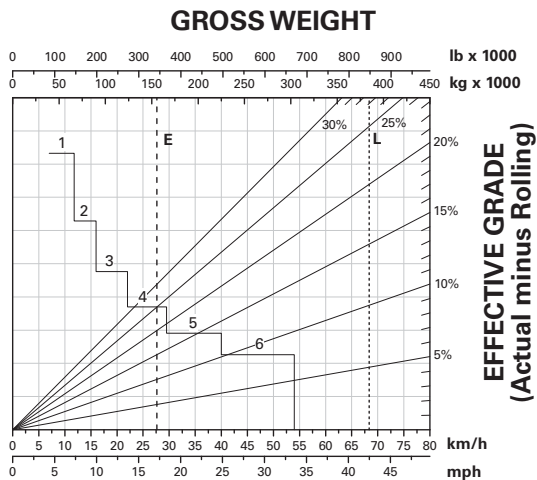

GRADE DISTANCE — 900 m (3000 ft)

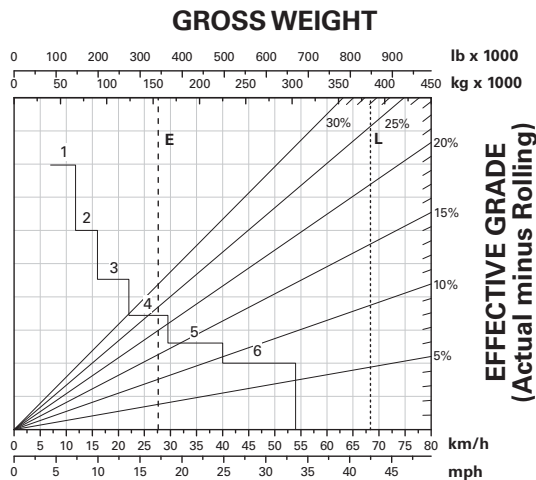

GRADE DISTANCE — 1500 m (5000 ft)

KEY

- 1 — 1st Gear
- 2 — 2nd Gear
- 3 — 3rd Gear
- 4 — 4th Gear
- 5 — 5th Gear
- 6 — 6th Gear

KEY

- E — Empty Operating Weight 154 729 kg (341,119 lb)
- L — Target GMW 383 740 kg (846,000 lb)

*At Sea Level.

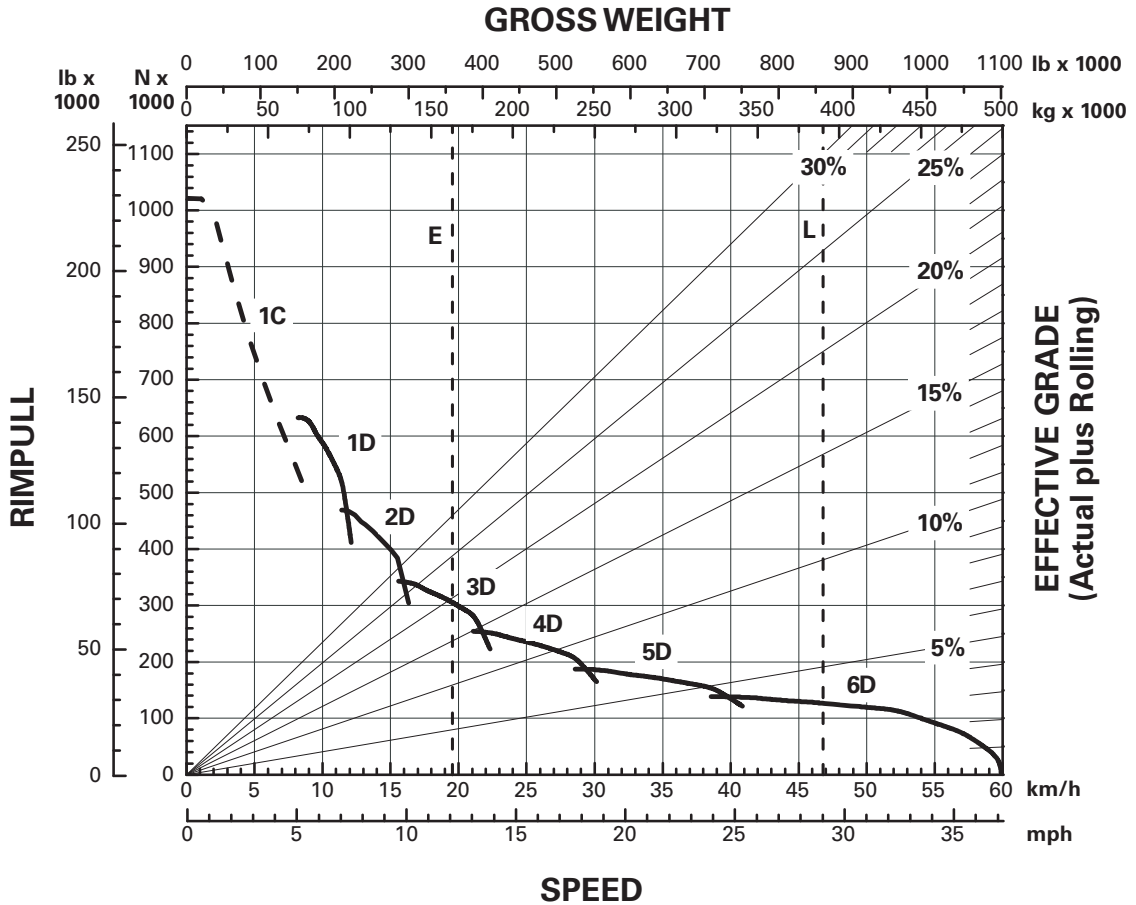

KEY

- 1 — 1st Gear
- 2 — 2nd Gear
- 3 — 3rd Gear
- 4 — 4th Gear
- 5 — 5th Gear
- 6 — 6th Gear

KEY

- E — Empty Operating Weight 165 144 kg (364,080 lb)
- L — Target GMW 390 090 kg (860,000 lb)

*At Sea Level.

- Standard Retarding
- Continuous Grade Retarding*

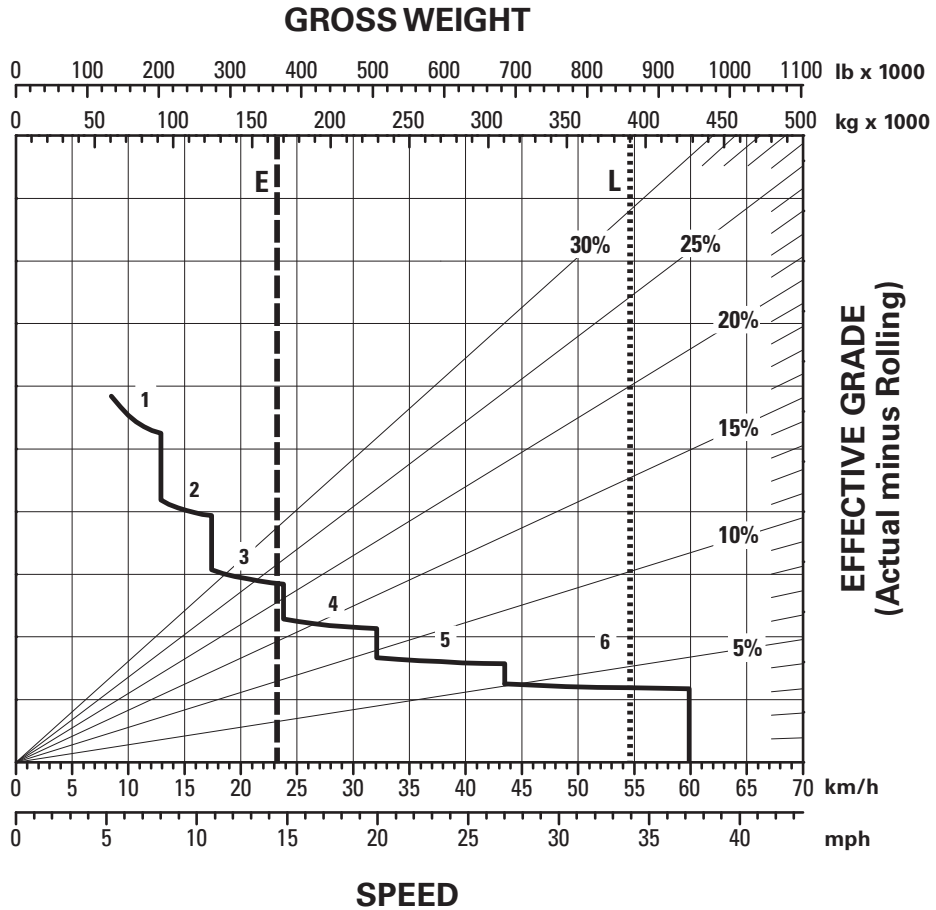

CONTINUOUS GRADE LENGTH

KEY

- 1 – 1st Gear
- 2 – 2nd Gear
- 3 – 3rd Gear
- 4 – 4th Gear
- 5 – 5th Gear
- 6 – 6th Gear

KEY

- E – Empty Operating Weight 165 144 kg (364,080 lb)
- L – Target GMW 390 090 kg (860,000 lb)

*At Sea Level.

793F Brake Performance

- Standard Retarding
- 450 m (1500 ft) ● 600 m (2000 ft)
- 900 m (3000 ft) ● 1500 m (5000 ft)

Mining & Off-Highway Trucks

GROSS WEIGHT

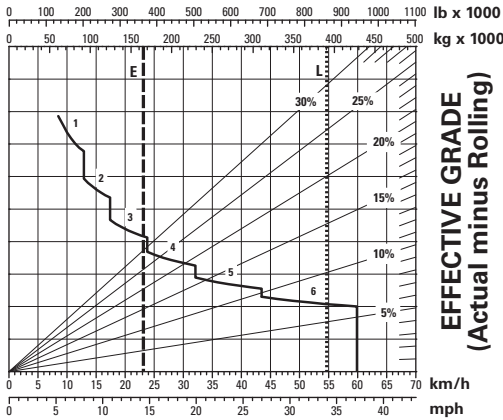

SPEED

GRADE DISTANCE — 450 m (1500 ft)*

GROSS WEIGHT

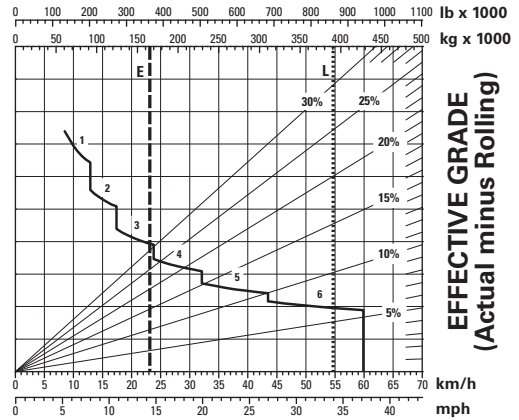

SPEED

GRADE DISTANCE — 600 m (2000 ft)*

GROSS WEIGHT

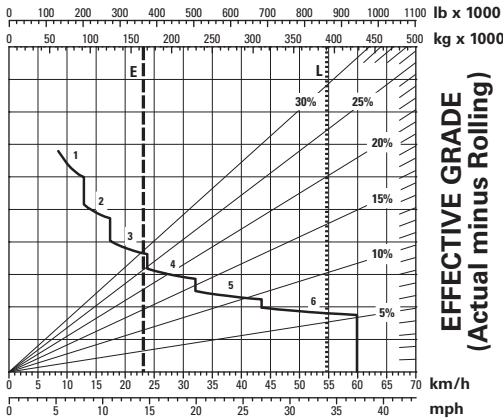

SPEED

GRADE DISTANCE — 900 m (3000 ft)*

GROSS WEIGHT

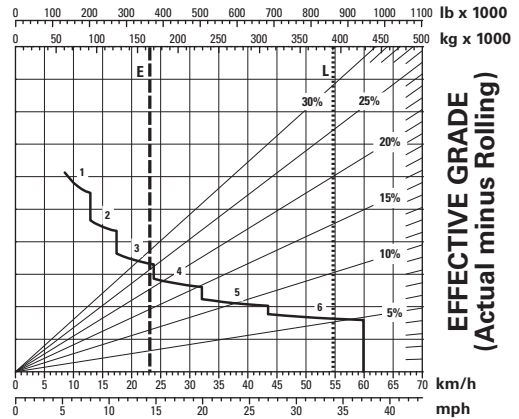

SPEED

GRADE DISTANCE — 1500 m (5000 ft)*

KEY

- 1 — 1st Gear
- 2 — 2nd Gear
- 3 — 3rd Gear
- 4 — 4th Gear
- 5 — 5th Gear
- 6 — 6th Gear

KEY

- E — Empty Operating Weight 165 144 kg (364,080 lb)
- L — Target GMW 390 090 kg (860,000 lb)

*At Sea Level.

- Additional Retarding
- Continuous Grade Retarding*

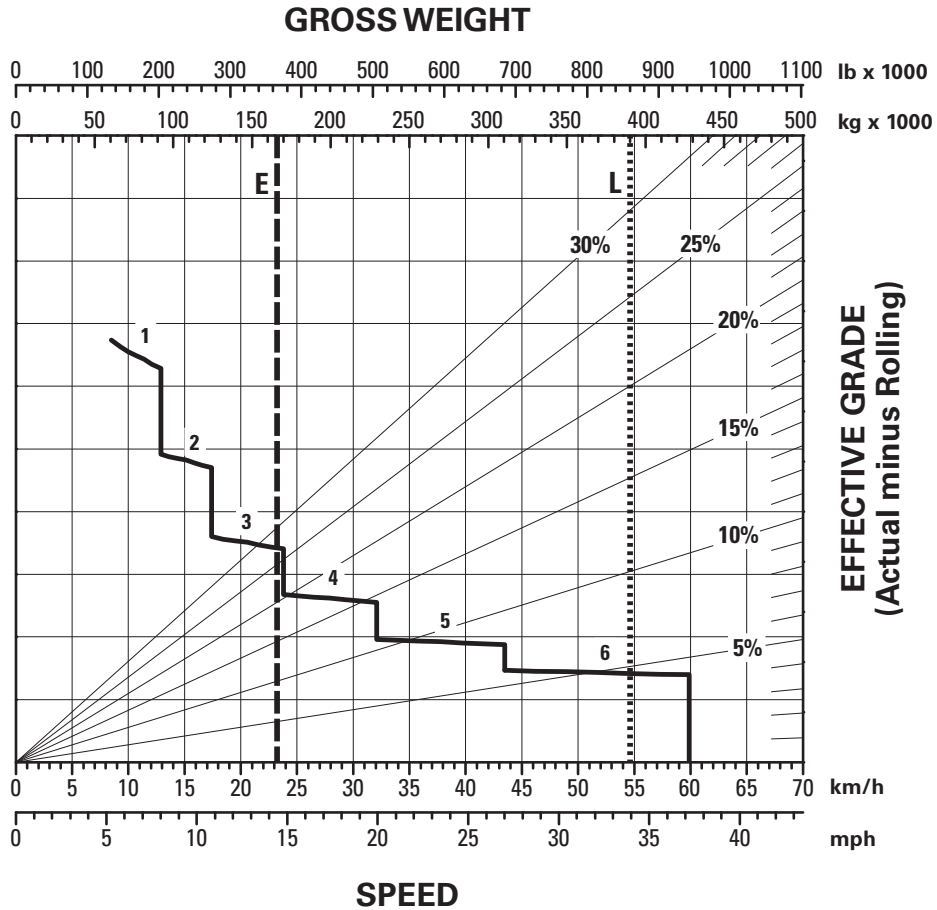

CONTINUOUS GRADE LENGTH

KEY

- 1 — 1st Gear
- 2 — 2nd Gear
- 3 — 3rd Gear
- 4 — 4th Gear
- 5 — 5th Gear
- 6 — 6th Gear

KEY

- E — Empty Operating Weight 165 144 kg (364,080 lb)
- L — Target GMW 390 090 kg (860,000 lb)

*At Sea Level.

793F Brake Performance

Mining & Off-Highway Trucks

- Additional Retarding
- 450 m (1500 ft) ● 600 m (2000 ft)
- 900 m (3000 ft) ● 1500 m (5000 ft)

GROSS WEIGHT

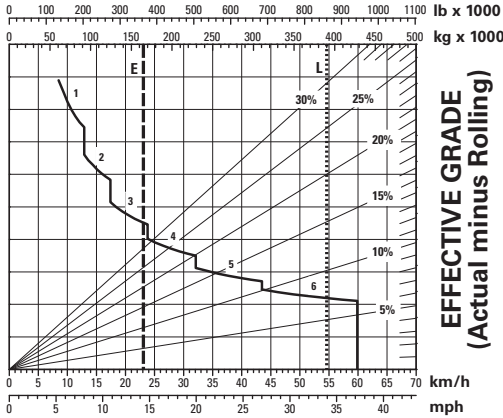

SPEED

GRADE DISTANCE — 450 m (1500 ft)*

GROSS WEIGHT

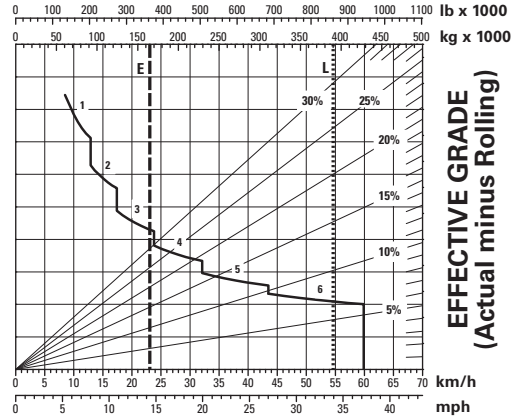

SPEED

GRADE DISTANCE — 600 m (2000 ft)*

GROSS WEIGHT

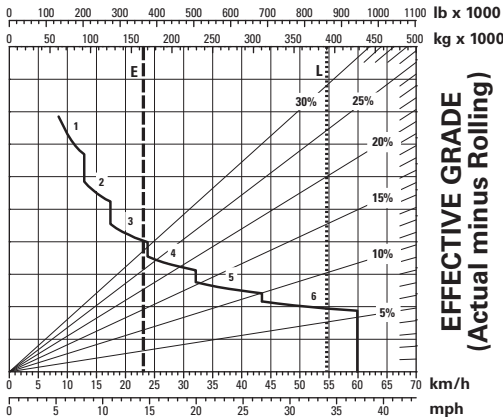

SPEED

GRADE DISTANCE — 900 m (3000 ft)*

GROSS WEIGHT

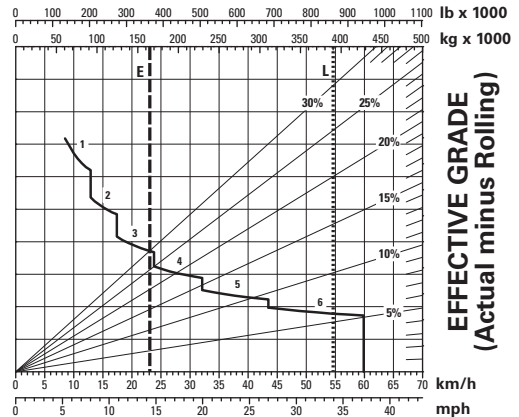

SPEED

GRADE DISTANCE — 1500 m (5000 ft)*

KEY

- 1 — 1st Gear
- 2 — 2nd Gear
- 3 — 3rd Gear
- 4 — 4th Gear
- 5 — 5th Gear
- 6 — 6th Gear

KEY

- E — Empty Operating Weight 165 144 kg (364,080 lb)
- L — Target GMW 390 090 kg (860,000 lb)

*At Sea Level.

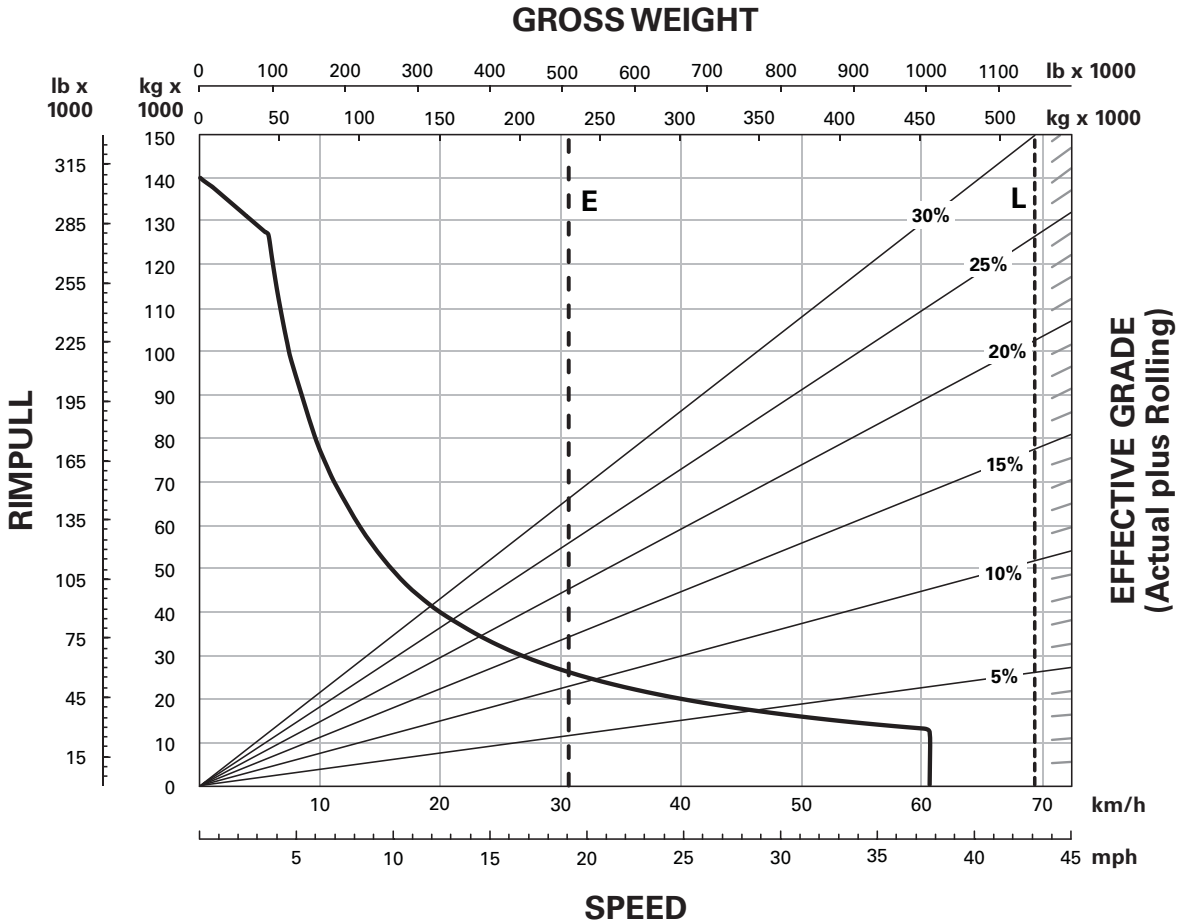

KEY

E – Empty Operating Weight 230 631 kg (508,454 lb)

L – Target GMW 521 631 kg (1,150,000 lb)

*At Sea Level.

MT5300D AC Brake Performance

- Continuous Grade Retarding*
- 53/80R63 Tires

Mining & Off-Highway Trucks

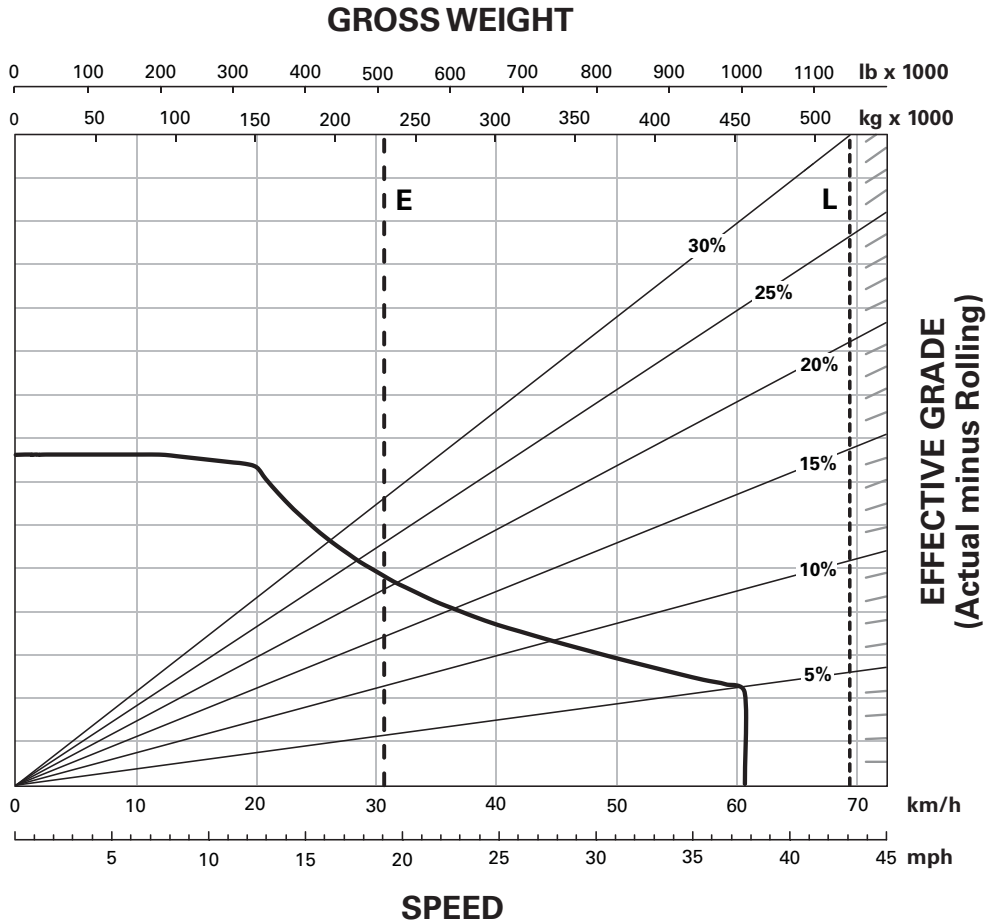

10

CONTINUOUS GRADE LENGTH

KEY

E – Empty Operating Weight 230 631 kg (508,454 lb)

L – Target GMW 521 631 kg (1,150,000 lb)

*At Sea Level.

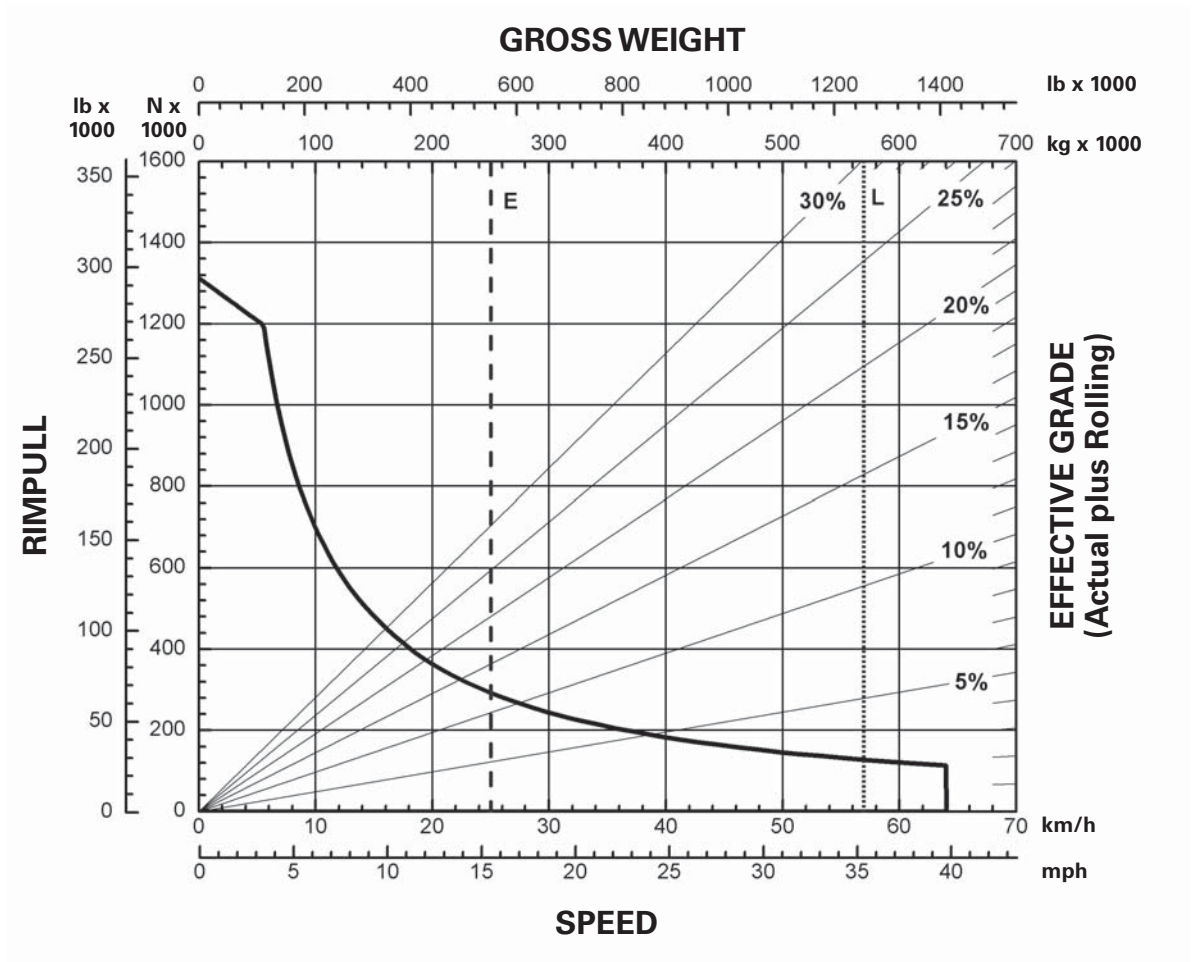

KEY

E – Empty Operating Weight 251 933 kg (555,417 lb)

L – Target GMW 570 166 kg (1,257,000 lb)

*At Sea Level.

- 795F Brake Performance
- Continuous Grade Retarding*
 - 56.80R63 Tires

Mining & Off-Highway Trucks

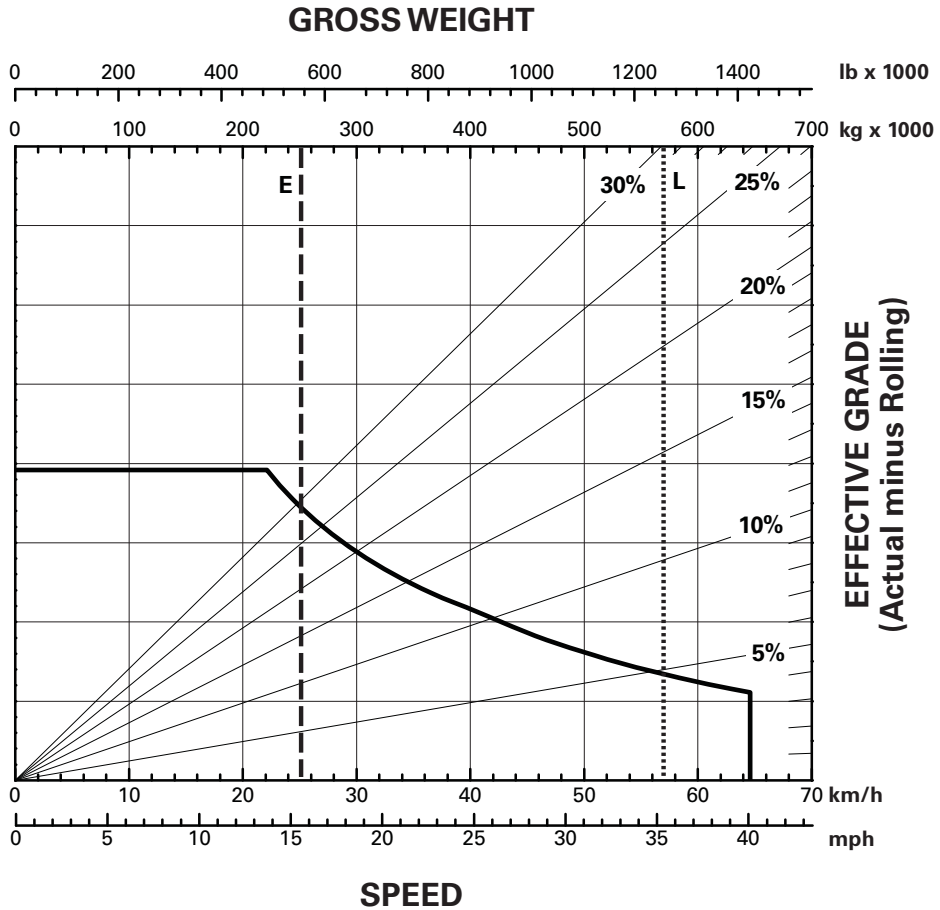

KEY

- E — Empty Operating Weight 251 933 kg (555,417 lb)
- L — Target GMW 570 166 kg (1,257,000 lb)

*At Sea Level.

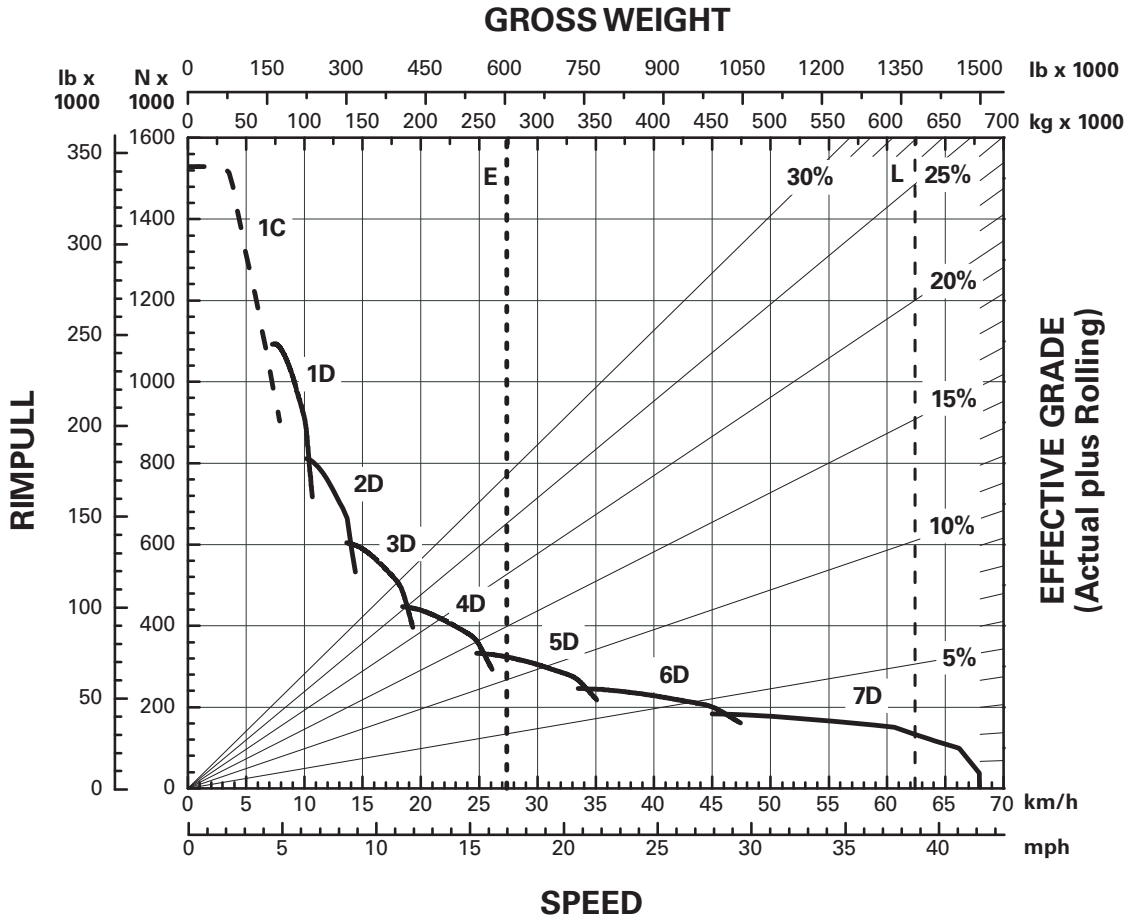

KEY

- 1 — 1st Gear
- 2 — 2nd Gear
- 3 — 3rd Gear
- 4 — 4th Gear
- 5 — 5th Gear
- 6 — 6th Gear
- 7 — 7th Gear

KEY

- E — Empty Operating Weight 274 415 kg (604,980 lb)
- L — Target GMW 623 690 kg (1,375,000 lb)

*At Sea Level.

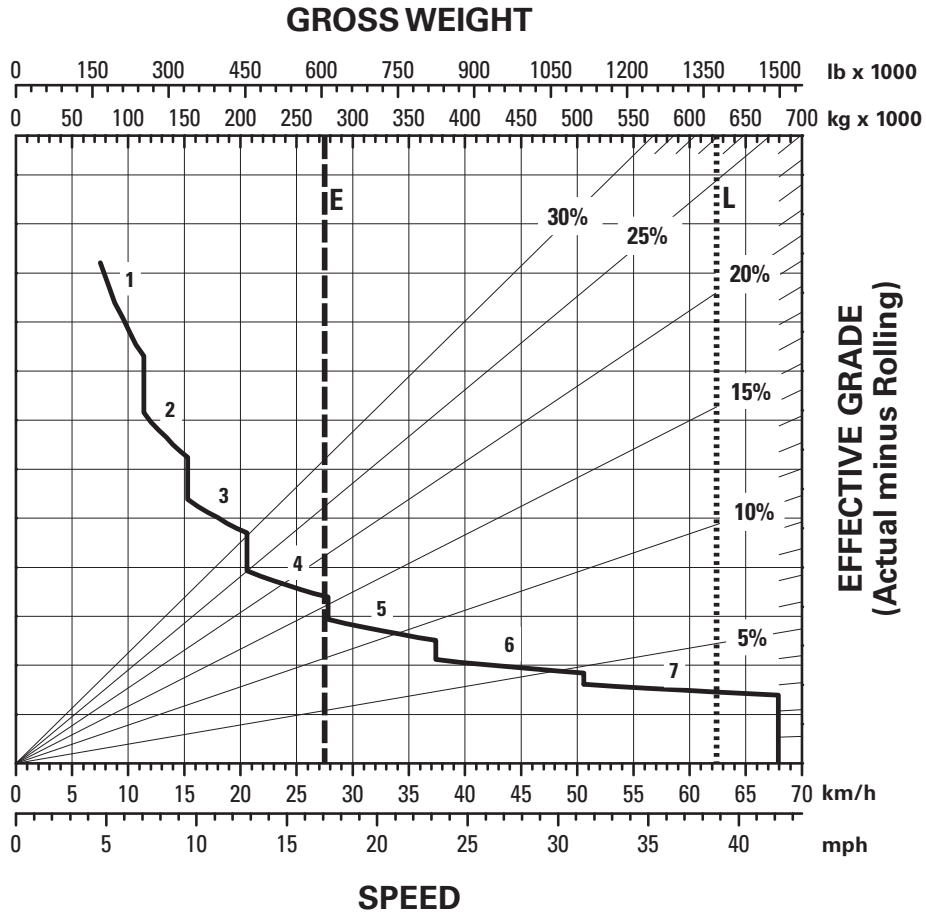

CONTINUOUS GRADE LENGTH

KEY

- 1 — 1st Gear
- 2 — 2nd Gear
- 3 — 3rd Gear
- 4 — 4th Gear
- 5 — 5th Gear
- 6 — 6th Gear
- 7 — 7th Gear

KEY

- E — Empty Operating Weight 274 415 kg (604,980 lb)
- L — Target GMW 623 690 kg (1,375,000 lb)

*At Sea Level.

Mining & Off-Highway Trucks

797F Brake Performance

- 450 m (1500 ft)
- 600 m (2000 ft)
- 900 m (3000 ft)
- 1500 m (5000 ft)

GROSS WEIGHT

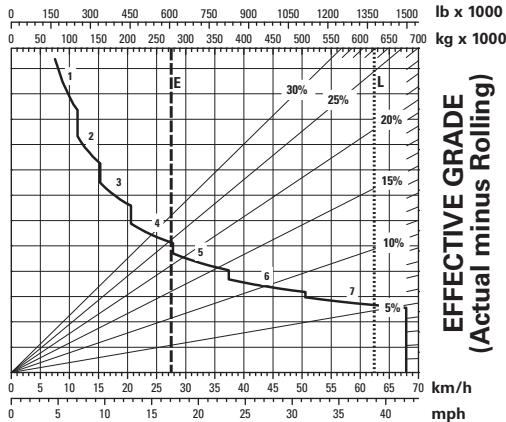

SPEED

GRADE DISTANCE — 450 m (1500 ft)*

GROSS WEIGHT

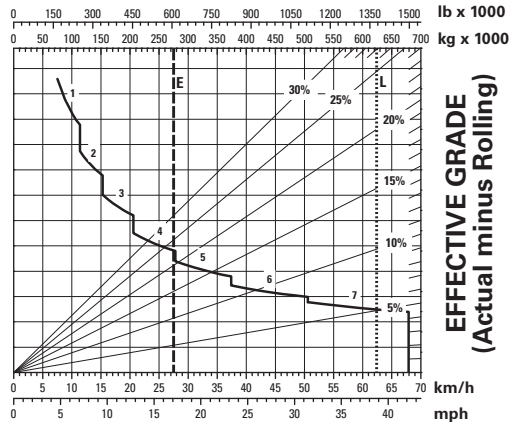

SPEED

GRADE DISTANCE — 600 m (2000 ft)*

GROSS WEIGHT

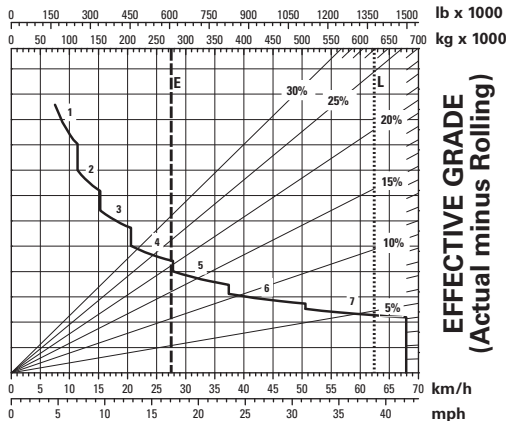

SPEED

GRADE DISTANCE — 900 m (3000 ft)*

GROSS WEIGHT

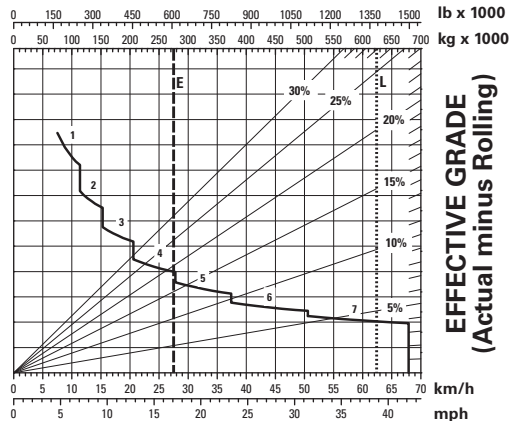

SPEED

GRADE DISTANCE — 1500 m (5000 ft)*

KEY

- 1 — 1st Gear
- 2 — 2nd Gear
- 3 — 3rd Gear
- 4 — 4th Gear
- 5 — 5th Gear
- 6 — 6th Gear
- 7 — 7th Gear

KEY

- E — Empty Operating Weight 274 415 kg (604,980 lb)
- L — Target GMW 623 690 kg (1,375,000 lb)

*At Sea Level.

MOTOR GRADERS

CONTENTS

Industries Served	11-1
Features	11-2
Applications	11-6
Specifications: Standard Versions	11-9
Specifications: Global Versions	11-12
Travel Speeds	11-19
All Wheel Drive (AWD)	11-21
Mid Mount and Front Mount Scarifiers	11-21
Rear Ripper and Rear Ripper Scarifier	11-22
Production	11-27
Formulas	11-29
Extreme Slope Operation	11-30
Work Tools	11-31

INDUSTRIES SERVED

The motor grader is one of the most versatile work tools in the Cat® product line. The M Series machines are used in numerous applications within a wide range of industries. The major industries using Cat motor graders, along with the typical applications within each, are summarized below.

● Heavy Construction

- Highway Construction
- Paving/Resurfacing
- Airport Construction
- Railroad Construction
- Dam and Levee Construction
- Haul Road Maintenance

● Governmental

- Road Maintenance
- Road Construction
- Ditch Building/Cleaning
- Snow Removal

● Building Construction

- Residential Construction
- Commercial Construction
- Industrial Construction
- Sewer and Water Systems

● Industrial

- Waste Disposal
- Pipeline Construction

● Mining

- Haul Road Maintenance
- Snow Removal

● Forestry

- Access Road Construction
- Forest Development
- Snow Removal
- Haul Road Maintenance

- **Geographic Versions** — Cat motor graders were specifically designed to meet the needs of different geographic regions and regulations. K/K2 Series for less regulated locations and M/M2/M3 Series are available with an assortment of standard features and optional equipment. All motor graders feature advanced electronically controlled Cat engines, power train components, hydraulics and machine structures.

FEATURES, M Series Motor Graders:

Building on the strong heritage of the H Series, the M Series delivers multiple technological breakthroughs, setting the new standard for motor graders. The H Series has been the industry standard in a variety of heavy construction, mining, road building and governmental applications. The M Series continues this tradition, incorporating revolutionary, customer-driven enhancements by:

- Improving ease of operation and operation training time
- Offering best-in-class operator station and unmatched visibility
- Delivering maximum productivity
- Improving availability and decreasing maintenance time

The M Series line includes eleven models: 120, 120 AWD, 140, 140 AWD, 160, 160 AWD, 12, 12 AWD, 14, 16, 24. The 120 through 14 meet construction, road building, and governmental applications. The All Wheel Drive models improve traction in poor underfoot conditions such as snow, mud, and sand. The 16 and 24 meet the specialized needs of large mining customers.

- **Operation Station:** The 120 through 16 models feature a revolutionary cab design that provides unmatched comfort, visibility, storage and ease of use, which can enhance operator confidence and productivity. The interior noise level is maintained between 70 and 74 dB(A) with the doors and windows closed.

Ease of Operation. The revolutionary joystick controls and exceptional visibility make operating easier without sacrificing control. The intuitive joystick control pattern allows both new and experienced operators to become productive quickly. Logical grouping of hydraulic functions in the joysticks allow any operator to easily control several functions at the same time. This allows the operator to be more productive and remain comfortable throughout the work shift.

Advanced Joystick Controls. Two electro-hydraulic joysticks reduce hand and wrist movement as much as 78% compared to conventional lever controls for greatly enhanced operator efficiency. The intuitive pattern is easy to learn and provides the precise implement control to allow both new and experienced operators to become productive quickly. Logical grouping of hydraulic functions in the joysticks allow any operator to control several functions at the same time for more productivity.

Visibility. The 120 through 16 models boast excellent visibility to the work area, made possible with angled cab doors, a tapered engine enclosure and a patented sloped rear window. Ample glass area and carefully placed components provide excellent visibility to enhance operator confidence and productivity in all motor grader applications. The cab design gives the operator an exceptional view forward to the blade, working surface and front tires. The black glare-reducing paint on the front frame and engine enclosure enhances visibility.

- **Drawbar, Circle and Moldboard:** The 120 through 16 models provide a broad range of extended blade positions particularly beneficial in mid-range bank sloping, ditch cutting and ditch cleaning. A long wheel base allows for an aggressive blade angle permitting material to roll more freely, reducing power requirements. Top-accessible drawbar wear inserts and the shimless moldboard retention system make DCM adjustments fast and simple, delivering more precise material control while lowering operating costs.

Top-Adjust Drawbar Wear Strips. The patented top-adjust wear strips dramatically reduce drawbar/circle adjustment time. By removing the access plates on top of the drawbar, shims and wear strips can easily be added or replaced. This feature reduces service downtime and lowers overall machine operating costs.

Shimless Moldboard Retention System. The unique shimless moldboard retention system reduces the potential for blade chatter. Adjusting screws keep the moldboard's wear strips aligned for precise blade control and dramatic reductions in service time.

- **Power Train:** Integrated, electronically controlled systems, deliver smooth reliable performance with reduced operating costs.

Smooth Shifting Transmission. The transmission design combines several key innovations to ensure smooth, powerful shifts throughout the gear range.

Advanced Productivity Electronics Control Strategy (APECS). APECS utilizes an electronic control strategy to read the input from sensors to shift the transmission at the optimal point. Event based shifting allows operators to experience faster, smoother and more consistent shifts. Note: M Series 3 Only.

Electronically Controlled Shifting. The full Electronic Clutch Pressure Control (ECPC) system optimizes inching modulation and smoothes shifting between all gears and directional changes. This provides outstanding control and also extends the life of the transmission by reducing stress on gears.

Load Compensation. This standard feature ensures consistent shift quality regardless of blade or machine load.

Hydraulic Brakes. The oil bathed, multi-disc service brakes are hydraulically actuated, providing smooth predictable braking and lower operating costs. With brakes located at each tandem wheel, the Cat motor graders offer the largest total brake surface area in the industry, delivering dependable stopping power and longer brake life.

- **Engine:** The Cat motor grader combines power management with ACERT™ Technology to deliver maximum power and efficiency while reducing the environmental impact.

ACERT Technology. ACERT Technology allows Cat engines to supply more power per unit of displacement without causing premature wear. This breakthrough technology reduces emissions during the combustion process by using advanced technology in the air and fuel systems, in conjunction with integrated electronics. ACERT Technology enhances overall engine performance while dramatically reducing exhaust emissions.

Power Management. Power Management utilizes Variable Horse Power (VHP) and Variable Horse Power Plus (VHP Plus) to optimize motor grader performance. VHP delivers additional power in the working gear while balancing fuel consumption, traction and horsepower. VHP Plus, delivers additional power in each forward gear 5th through 8th for increased speed on grade and performance.

Exhaust Emission Standards. The Cat ACERT Technology engines in the M Series Motor Graders meet U.S. EPA Tier 3/EU Stage IIIA equivalent/Japan 2006 (Tier 3) emission standards. The M Series 2 machines meet U.S. EPA Tier 4 Interim/EU Stage IIIB/Japan 2011 (Tier 4 Interim) equivalent emission standards. The M Series 3 machines meet U.S. EPA Tier 4 Final/EU Stage IV/Japan 2014 (Tier 4 Final) emission standards.

- **Hydraulics:** Electro-hydraulics enable advanced machine controls with precise and predictable movements.

Advanced Electro-Hydraulic System. The Cat motor grader product line incorporates a state-of-the-art electro-hydraulic system. This technology is the foundation for revolutionary changes of the machine and implement controls. Advanced joystick controls provide unmatched controllability with precise, predictable hydraulic movements and the reliability you expect from Cat products.

Load Sensing Hydraulics (PPPC). The time proven load-sensing system and the advanced Proportional Priority Pressure-Compensating (PPPC, or “triple-PC”) electro-hydraulic valves are designed to provide superior implement control and enhanced machine performance in all applications. Continuous matching of hydraulic flow and pressure to power demands creates less heat and reduces power consumption.

- **Serviceability:**

Grouped Service Points. Grouped daily service points in the left side service center help ensure proper maintenance and inspection routines.

Extended Service Intervals. Extended service intervals, such as 500-hour engine oil changes and 4000-hour hydraulic oil changes, reduce machine service time and increase availability.

Ecology Drains. Conveniently located ecology drains shorten service times and help keep the environment safe by preventing spills.

Diagnostics and Monitoring. Cat Messenger and Cat Message are offered as standard equipment to enhance diagnostic capabilities by displaying machine system errors and fault codes. Cat Electronic Technician is a two way communication tool that provides easy access to stored diagnostic data and lets technicians configure machine parameters through the Cat Data Link. Product Link™ provides a communication flow of vital machine data and location. Cat motor graders integrate Cat Messenger, Cat Electronic Technician, and S•O•SSM analysis for easy monitoring and fast troubleshooting, keeping your machine up and running. Note: Cat Messenger is standard on M Series and M Series 2 only. Cat Message is standard on M Series 3 only.

- **Safety.** Safety is an integral part of all machine and system designs. Cat motor graders provide a safe working environment for both the operator and ground personnel. ROPS and FOPS structures meeting current SAE and ISO requirements are standard on all Global machines. Back-up alarms are a standard feature.

Operator Presence System. The Operator Presence System keeps the parking brake engaged until the operator is seated for safe operation.

Secondary Steering System. The standard secondary steering system automatically engages in case of a drop in steering pressure, allowing the operator to steer the machine to a stop.

Speed Sensitive Steering. The steering software automatically provides an infinitely variable ratio between the joystick and the steer tires, resulting in less sensitive steering as the groundspeed increases.

Hydraulic Lockout. A simple switch located in the cab disables all implement functions while still providing machine steering control. This safety feature is especially useful while the machine is roading.

Circle Drive Slip Clutch. This standard feature protects the drawbar, circle and moldboard from shock loads when the end of the blade encounters immovable objects. It also reduces the possibility of abrupt directional changes in poor traction conditions, protecting the machine, operator and surroundings.

Blade Lift Accumulators. This optional feature uses accumulators to help absorb impact loads to the moldboard by allowing vertical blade travel. Blade lift accumulators reduce unnecessary wear and help to avoid unintended machine movement for increased operator safety.

Drop-Down Rear Lights. Optional drop-down lights fold out from the rear of the machine. This creates a wider, lower profile, to be better aligned with passenger cars.

Rearview Camera. Visibility is further enhanced with an optional Work Area Vision System (WAVS) LCD color monitor in the cab.

- **Automatic Differential Lock/Unlock.** The Auto Diff-Lock feature automatically unlocks the differential during a turn, re-locks when straight, for easier operation and improved power train protection.
- **Swing Out Cooling Fan.** This standard feature allows for easy access to the cooling cores reducing time required for clean out. The latched door requires no tools for opening and closing. Note: M Series 2 and M Series 3 Only.

FEATURES, K Series Motor Graders:

Overview

The K Series model line-up is targeted to meet customer requirements in less regulated countries. Built on the success of the Standard H Series, the K Series delivers multiple improvements in emissions control and operator features, while still maintaining the industry standard for reliability. The K Series model line up consists of the 120K, 120K2, 12K, 140K, 140K2, and 160K.

Engine

- **ACERT Engine Technology:** Cat ACERT engine technology utilizes numerous advanced components to efficiently produce more power and reduce emissions.
- **Emissions:** The K Series Motor Graders meet U.S. EPA Tier 2/EU Stage II equivalent emission standards. The K Series 2 machines are certified to Bharat Stage III and China Stage II emission standards.
- **Power Management Strategy:** The K Series power management strategy provides an additional 7.5 kW (10 hp) increase in third and another 7.5 kW (10 hp) in fourth gear through Variable Horsepower (VHP). This allows the operator to maintain maximum rim-pull while increasing ground speed and productivity.

Power Train

- **Electronic Clutch Pressure Control (ECPC):** This standard feature smoothes shifts and improves inching control. The system uses input from the transmission and operator controls to modulate the directional clutches and produce consistent shifting.
- **Autoshift:** This optional feature improves ease of operation and maximizes productivity by automatically shifting the transmission at optimal shifting points.

Serviceability

- **Grouped Service Points:** Grouped daily service points in the left side service center help ensure proper maintenance and inspection routines.
- **Diagnostic Capability:** The improved dash cluster keeps the operator informed of critical system conditions. Cat Electronic Technician is also offered, allowing faster diagnostic capabilities by service personnel. Product Link allows tracking of vital machine data and location, providing a convenient way to track the machine.
- **Extended Service Intervals:** Improvements in serviceability allow increased machine operation between service intervals. The machines can operate a full 500 hours between engine oil and filter changes, 4,000 hours between hydraulic oil changes, and 12,000 hours between engine coolant changes. This reduces downtime and operating expense.

APPLICATIONS, Motor Graders:

The broad line of Cat motor graders allows the customer to choose a motor grader that best fits the intended application. Below is a summary of the typical motor grader applications.

Finish Grading

This application involves preparing a roadway or site surface for future paving or other construction activity. The material being moved is usually a hard, dry base material on a solid underfoot. Finish blading is the motor grader application that requires the highest degree of accuracy. Thus, it is primarily done at low operating speeds — usually less than 5 km/h (3 mph) — in gears 1 and 2. To ensure a smooth, even finished surface, one gear is usually maintained for a given pass. Pass lengths during this application are usually less than 600 m (2000 feet) for road construction and 150 m (500 feet) for site development. Most finish blading is performed by contractors in the Heavy Construction and Building Construction industries.

Heavy Blading

This application involves cutting, moving, and mixing material, usually in the initial stages of surface preparation. A variety of material types are moved in this manner, and the blade tip position varies accordingly. Full blade loads are usually experienced during heavy blading, since moving material is the primary goal. Pass lengths within this application vary, but are usually less than 600 m (2000 feet). Unlike finish blading, the speed of the machine is dependent on the load being moved when heavy blading material. Typical operating speeds are from 0-10 km/h (0 to 6 mph). Therefore, gears 2 through 4 are frequently used in this application. Most heavy blading activity is performed by contractors in the Heavy Construction, Governmental, Industrial, and Forestry industries.

Site Preparation

This application involves any material cutting, moving, and mixing necessary to prepare a residential, commercial, or industrial site for construction. A variety of materials are encountered in this application. Blade loads vary depending on the activity being performed. Both heavy blading and finish blading are performed when preparing a site. Pass lengths are typically in the range of 30-300 m (100 to 1000 feet). Typical operating speeds for site preparation vary depending on whether heavy blading or finish blading activities are being performed. Most site preparation activities are performed by contractors in the Building Construction industry.

Road Maintenance

This application involves reshaping dirt or gravel roads to maintain a crown or superelevation, or restoring the surface itself. This generally involves secondary roads maintained by governmental bodies such as townships and counties. Materials being moved in this application vary from extremely hard dirt bases to moist gravel surfaces. The typical blade load falls between that of finish blading and heavy blading. Pass lengths are frequently longer than 600 m (2000 feet) and can extend for miles. The general speed range for this application is 5-16 km/h (3 to 10 mph), corresponding to gears 2 (heavy dirt) through 5 (soft gravel). As with finish blading, accuracy of the graded surface is the primary concern in this application. Thus, frequent shifts should be avoided whenever possible. A gear should be chosen and maintained unless there is a significant change in the material being moved. Most road maintenance activities are performed by the Governmental industry.

Haul Road Maintenance

This application of the motor grader involves reshaping haul roads at mining, construction, or forestry work sites, usually for the purpose of maintaining smooth travel surfaces for equipment. Materials being moved while maintaining haul roads vary widely. Typical blade loads are about one-third to half of full capacity. Haul roads that experience large hauling units travelling on soft material may require heavy blade loads in order to reshape the road surface. Pass lengths vary depending on the application but can extend for miles on remote forestry or large mine haul roads. The general speed range for haul road maintenance is heavily dependent on the material being moved as well as the grade of the haul road. Many mine sites are in mountainous areas, requiring haul roads with steep grades. Generally, haul-road maintenance is performed at speeds similar to those required for general road maintenance 5-16 km/h (3 to 10 mph).

A travel surface that allows for the safe and efficient movement of machinery is the ultimate goal with this motor grader application. Very precise roadway elevations and slopes are desired but less crucial than when finish blading. Most haul road maintenance activities are performed by the Mining, Heavy Construction, and Forestry industries.

Side/Bank Slope Work

This application involves preparing side slopes or bank slopes along roadways by placing the moldboard on a sloped surface. Slopes of up to a 2:1 angle can be cut using a motor grader. Often the motor grader is operated on the level surface adjacent to the slope, and the moldboard is extended outward to the sloped surface. Fine soils are generally encountered in this application of the motor grader. Blade loads are usually less than half of the full blade capacity, and pass lengths are seldom longer than 600 m (2000 feet). A smooth-graded sloped surface is the primary concern in this application so frequent shifts should be avoided. The typical speed range is 0-6 km/h (0 to 4 mph), corresponding to a gear selection of 1 to 3. The nominal speed is heavily dependent on the type of material being moved and on the slope of the surface. Most side/bank slope work is performed by the Heavy Construction and Governmental industries.

Ditch Building/Cleaning

This application involves cutting “V” and flat-bottom ditches for drainage purposes and rebuilding them when necessary. Due to excessive rain and/or poor material, ditches often need cleaning and reshaping. When building ditches, materials with a wide range of densities are encountered. Blade loads vary accordingly, from half to full-blade capacity. Pass lengths are usually less than 600 m (2000 feet). The primary objective is to move material in a manner that yields a ditch with the desired slope. Ditch building often involves cutting and moving material of high density. Therefore, typical speed ranges vary. Most ditch building work, however, is performed in gears 1 through 3, corresponding to a maximum speed of about 8 km/h (5 mph). Ditch cleaning usually involves blading moist materials underneath a sod cover. Blade loads are usually less than half of full blade capacity when cleaning ditches, and pass lengths are similar to those encountered in ditch building. Typical maximum speeds for this activity are similar to that of ditch building, but less of a blade load is experienced. Ditch building and cleaning activities are usually performed by the Heavy Construction and Governmental industries.

Ripping/Scarifying

This application involves conditioning hard, rough soils before they are bladed. Shanks on the ripper and/or scarifier are pushed into the ground, thus breaking up otherwise hard surfaces. Hard materials such as asphalt can also be loosened in order to make grading operations less damaging to the moldboard. Rippers and scarifiers can also be used to mix aggregates together. The materials being ripped/scarified are usually hard and dry. Rippers generally penetrate 150-300 mm (6 to 12 inches) into the ground, while scarifiers typically penetrate to a depth of 25-200 mm (1 to 8 inches). Pass lengths are generally less than 600 m (2000 feet) for both activities. Since the material being ripped/scarified is generally hard, the typical maximum speed for this application is about 6 km/h (4 mph) gears 1-2. If the ripper/scarifier is used for mixing aggregates, the typical operating range becomes 6-20 km/h (4 to 12 mph) gears 3-6. Most ripping/scarifying activities are performed by the Heavy Construction and Governmental industries.

Snow Removal

Snow removal is the process of cutting and removing snow or ice from the roadway. In addition to the standard motor grader moldboard, other attachments such as a snow wing, V-plow, one-way plow, or reversible plow can be used to remove the snow. The moldboard itself is the most commonly used attachment for snow plowing. It is used in areas where snow depths are low, the terrain is relatively flat, and where excessive drifting does not occur. A snow wing is a moldboard that attaches to the machine's right side. The wing's curvature lifts the snow and "wings" it off the plowed surface. The snow wing is often used in conjunction with the standard moldboard, where the moldboard cuts the material and feeds it onto the wing. V-plows are mounted in front of the motor grader and are designed to dig into and lift packed snow. The typical speed range for snow removal is 10-30 km/h (6 to 18 mph), corresponding to a gear range of 3 to 7. Snow plowing often involves lower speeds than snow removal. The typical operating range for snow plowing is 8-19 km/h (5 to 12 mph) gears 2 to 4. The majority of Snow Removal/Plowing operations are performed by the Governmental, Mining, and Forestry industries.

MODEL	120K		12K	
Net Flywheel Power: Gears 4-8	108 kW	145 hp	123 kW	165 hp
Gear 3▲	101 kW	135 hp	116 kW	156 hp
Gears 1-2▲	93 kW	125 hp	108 kW	145 hp
Operating Weight (Typical)*	13 843 kg	30,519 lb	14 308 kg	31,543 lb
Engine Model	C7 ACERT VHP		C7 ACERT VHP	
Rated Engine RPM	2000		2000	
No. of Cylinders	6		6	
Displacement	7.2 L	439 in ³	7.2 L	439 in ³
Max. Torque	774 N·m	571 lb-ft	881 N·m	650 lb-ft
No. of Speeds Forward/Reverse	8/6		8/6	
Top Speed: Forward	47.5 km/h	29.5 mph	46.8 km/h	29.0 mph
Reverse	37.5 km/h	23.3 mph	36.8 km/h	22.9 mph
Std. Tires — Front and Rear	13.00-24 (12 PR) (G-2)		13.00-24 (12 PR) (G-2)	
Front Axle/Steering:				
Oscillation Angle	32°		32°	
Wheel Lean Angle	18°		18°	
Steering Angle	47.5°		47.5°	
Articulation Angle	20°		20°	
Minimum Turning Radius**	7.3 m	23'11"	7.5 m	24'7"
Front Frame Section Modulus:				
Min.	1619 cm ³	99 in ³	2083 cm ³	127 in ³
Max.	3681 cm ³	225 in ³	4785 cm ³	291 in ³
No. Circle Support Shoes	4		6	
Hydraulics: Pump Type	Variable Piston		Variable Piston	
Max. Pump Flow	210 L/min	55.7 gpm	210 L/min	55.7 gpm
Reservoir Tank Capacity	55 L	14.5 U.S. gal	55 L	14.5 U.S. gal
Implement Pressure: Max.	25 500 kPa	3699 psi	25 500 kPa	3699 psi
Min.	3600 kPa	522 psi	3600 kPa	522 psi
Electrical:				
System Size	24V		24V	
Std. Battery CCA @ 0° F	750		750	
Std. Alternator	115 amp		115 amp	
GENERAL DIMENSIONS:				
Height (to top of ROPS)	3.33 m	10'11"	3.35 m	11'0"
Height (No Cab/Canopy)***	2.88 m	9'6"	3.05 m	10'0"
Overall Length	8.24 m	27'0"	8.50 m	27'11"
With Ripper and Pushplate	9.77 m	32'1"	10.01 m	32'10"
Wheelbase	5.87 m	19'3"	6.09 m	20'0"
Blade Base	2.60 m	8'6"	2.60 m	8'6"
Overall Width (at top of front tires)	2.46 m	8'1"	2.48 m	8'2"
Standard Blade: Length	3.66 m	12'0"	3.66 m	12'0"
Height	610 mm	2'0"	610 mm	2'0"
Thickness	22 mm	0.87"	22 mm	0.87"
Lift Above Ground	410 mm	16"	480 mm	18.9"
Max. Shoulder Reach:◀				
Frame Straight — Right	1.93 m	6'4"	1.81 m	5'11"
Frame Straight — Left	1.76 m	5'9"	1.86 m	6'1"
Fuel Tank Capacity	305 L	80.6 U.S. gal	305 L	80.6 U.S. gal

*Typical Operating Weight — based on standard machine configuration, with Cab High Profile ROPS, 13.00-24 12 PR (G-2) tires, full fuel tank, coolant, lubricants and operator.

**Minimum Turning Radius — combining the use of articulated frame steering, front wheel steer and unlocked differential.

***Height (No Cab/Canopy) — without ROPS, exhaust, or other easily removed encumbrances.

◀ Applicable for the standard blade with hydraulic sideshift and tip control. Maximum shoulder reach is obtainable to the right.

▲ Engine Power Management automatically reduces power in gears 1F-3F and 1R-2R.

MODEL	140K		160K	
Net Flywheel Power: Gears 4-8	143 kW	191 hp	154 kW	206 hp
Gear 3▲	135 kW	181 hp	147 kW	196 hp
Gears 1-2▲	128 kW	171 hp	139 kW	186 hp
Operating Weight (Typical)*	15 108 kg	33,307 lb	15 873 kg	34,994 lb
Engine Model	C7 ACERT VHP		C7 ACERT VHP	
Rated Engine RPM	2000		2000	
No. of Cylinders	6		6	
Displacement	7.2 L	439 in³	7.2 L	439 in³
Max. Torque	996 N·m	735 lb-ft	1076 N·m	794 lb-ft
No. of Speeds Forward/Reverse	8/6		8/6	
Top Speed: Forward	47.3 km/h	29.4 mph	46.9 km/h	29.1 mph
Reverse	37.4 km/h	23.2 mph	37.0 km/h	23.0 mph
Std. Tires — Front and Rear	14.00-24 (12 PR) (G-2)		14.00-24 (12 PR) (G-2)	
Front Axle/Steering:				
Oscillation Angle	32°		32°	
Wheel Lean Angle	18°		18°	
Steering Angle	47.5°		47.5°	
Articulation Angle	20°		20°	
Minimum Turning Radius**	7.5 m	24'7"	7.5 m	24'7"
Front Frame Section Modulus:				
Min.	2083 cm ³	127 in³	2083 cm ³	127 in³
Max.	4785 cm ³	291 in³	4785 cm ³	291 in³
No. Circle Support Shoes	6		6	
Hydraulics: Pump Type	Variable Piston		Variable Piston	
Max. Pump Flow	210 L/min	55.7 gpm	210 L/min	55.7 gpm
Reservoir Tank Capacity	55 L	14.5 U.S. gal	55 L	14.5 U.S. gal
Implement Pressure: Max.	25 500 kPa	3699 psi	25 500 kPa	3699 psi
Min.	3600 kPa	522 psi	3600 kPa	522 psi
Electrical:				
System Size	24V		24V	
Std. Battery CCA @ 0° F	750		750	
Std. Alternator	115 amp		115 amp	
GENERAL DIMENSIONS:				
Height (to top of ROPS)	3.35 m	11'0"	3.35 m	11'0"
Height (No Cab/Canopy)***	3.05 m	10'0"	3.05 m	10'0"
Overall Length	8.50 m	27'11"	8.50 m	27'11"
With Ripper and Pushplate	10.01 m	32'10"	10.01 m	32'10"
Wheelbase	6.09 m	20'0"	6.09 m	20'0"
Blade Base	2.60 m	8'6"	2.60 m	8'6"
Overall Width (at top of front tires)	2.48 m	8'2"	2.48 m	8'2"
Standard Blade: Length	3.66 m	12'0"	4.27 m	14'0"
Height	610 mm	2'0"	686 mm	2'3"
Thickness	22 mm	0.87"	25 mm	1"
Lift Above Ground	480 mm	18.9"	452 mm	17.8"
Max. Shoulder Reach:◀				
Frame Straight — Right	1.98 m	6'6"	2.26 m	7'5"
Frame Straight — Left	1.90 m	6'3"	2.22 m	7'4"
Fuel Tank Capacity	305 L	80.6 U.S. gal	344 L	90.9 U.S. gal

***Typical Operating Weight** — based on standard machine configuration, with Cab High Profile ROPS, 14.00-24 12 PR (G-2) tires, full fuel tank, coolant, lubricants and operator.

****Minimum Turning Radius** — combining the use of articulated frame steering, front wheel steer and unlocked differential.

*****Height (No Cab/Canopy)** — without ROPS, exhaust, or other easily removed encumbrances.

◀ Applicable for the standard blade with hydraulic sideshift and tip control. Maximum shoulder reach is obtainable to the right.

▲ Engine Power Management automatically reduces power in gears 1F-3F and 1R-2R.

MODEL	120K2		140K2	
Net Flywheel Power: Gears 4-8	108 kW	145 hp	143 kW	191 hp
Gear 3▲	101 kW	135 hp	135 kW	181 hp
Gears 1-2▲	93 kW	125 hp	128 kW	171 hp
Operating Weight (Typical)*	13 843 kg	30,519 lb	15 108 kg	33,307 lb
Engine Model	C7 ACERT VHP		C7 ACERT VHP	
Rated Engine RPM	2000		2000	
No. of Cylinders	6		6	
Displacement	7.2 L	439 in ³	7.2 L	439 in ³
Max. Torque	774 N·m	571 lb-ft	996 N·m	735 lb-ft
No. of Speeds Forward/Reverse	8/6		8/6	
Top Speed: Forward	47.5 km/h	29.5 mph	47.3 km/h	29.4 mph
Reverse	37.5 km/h	23.3 mph	37.4 km/h	23.2 mph
Std. Tires — Front and Rear	14.00-24 12 PR (G-2)		14.00 24 (10 PR) (G-2)	
Front Axle/Steering:				
Oscillation Angle	32°		32°	
Wheel Lean Angle	18°		18°	
Steering Angle	47.5°		47.5°	
Articulation Angle	20°		20°	
Minimum Turning Radius**	7.3 m	23'11"	7.5 m	24'7"
Front Frame Section Modulus:				
Min.	1619 cm ³	99 in ³	2083 cm ³	127 in ³
Max.	3681 cm ³	225 in ³	4785 cm ³	291 in ³
No. Circle Support Shoes	4		6	
Hydraulics: Pump Type	Variable Piston		Variable Piston	
Max. Pump Flow	210 L/min	55.7 gpm	210 L/min	55.7 gpm
Reservoir Tank Capacity	55 L	14.5 U.S. gal	55 L	14.5 gal
Implement Pressure: Max.	25 500 kPa	3699 psi	25 500 kPa	3699 psi
Min.	3600 kPa	522 psi	3600 kPa	522 psi
Electrical:				
System Size	24V		24V	
Std. Battery CCA @ 0° F	750		750	
Std. Alternator	115 amp		115 amp	
GENERAL DIMENSIONS:				
Height (to top of ROPS)	3.33 m	10'11"	3.35 m	11'0"
Height (No Cab/Canopy)***	2.88 m	9'6"	3.05 m	10'0"
Overall Length	8.24 m	27'0"	8.50 m	27'11"
With Ripper and Pushplate	9.77 m	32'1"	10.01 m	32'10"
Wheelbase	5.87 m	19'3"	6.09 m	20'0"
Blade Base	2.60 m	8'6"	2.60 m	8'6"
Overall Width (at top of front tires)	2.46 m	8'1"	2.48 m	8'2"
Standard Blade: Length	3.66 m	12'0"	3.66 m	12'0"
Height	610 mm	2'0"	610 mm	2'0"
Thickness	22 mm	0.87"	22 mm	0.87"
Lift Above Ground	410 mm	16"	480 mm	18.9"
Max. Shoulder Reach:◀				
Frame Straight — Right	1.93 m	6'4"	1.98 m	6'6"
Frame Straight — Left	1.76 m	5'9"	1.90 m	6'3"
Fuel Tank Capacity	305 L	80.6 U.S. gal	305 L	80.6 U.S. gal

*Typical Operating Weight — based on standard machine configuration, with Cab High Profile ROPS, 14.00-24 12 PR (G-2) tires, full fuel tank, coolant, lubricants and operator.

**Minimum Turning Radius — combining the use of articulated frame steering, front wheel steer and unlocked differential.

***Height (No Cab/Canopy) — without ROPS, exhaust, or other easily removed encumbrances.

◀ Applicable for the standard blade with hydraulic sideshift and tip control. Maximum shoulder reach is obtainable to the right.

▲ Engine Power Management automatically reduces power in gears 1F-3F and 1R-2R.

MODEL	120M		12M	
Base Power — Net	103 kW	138 hp	136 kW	183 hp
VHP Range — Net	103-114 kW	138-153 hp	136-144 kW	183-193 hp
VHP Plus Range — Net	103-136 kW	138-182 hp	136-159 kW	183-213 hp
Operating Weight*	14 493 kg	31,951 lb	16 231 kg	35,783 lb
Engine Model	C6.6 ACERT		C7 ACERT	
Rated Engine RPM	2000		2000	
No. of Cylinders	6		6	
Displacement	6.6 L	403 in³	7.2 L	439 in³
Max. Torque	906 N·m	668 lb-ft	1052 N·m	776 lb-ft
No. of Speeds Forward/Reverse	8/6		8/6	
Top Speed: Forward	47.5 km/h	29.5 mph	46.6 km/h	29.0 mph
Reverse	37.5 km/h	23.3 mph	36.8 km/h	22.9 mph
Std. Tires — Front and Rear	14.00 24 (12 PR) (G-2)		14.00 24 (10 PR) (G-2)	
Front Axle/Steering:				
Oscillation Angle	32°		32°	
Wheel Lean Angle	18.0°		18.0°	
Steering Angle	47.5°		47.5°	
Articulation Angle	20°		20°	
Minimum Turning Radius**	7.3 m	24'1"	7.6 m	24'10"
No. Circle Support Shoes	4		6	
Hydraulics:				
Pump Type	Variable Piston		Variable Piston	
Max. Pump Flow	210 L	55.7 gpm	210 L/min	55.7 gpm
Tank Capacity	64 L	16.9 U.S. gal	64 L	16.9 U.S. gal
Implement Pressure: Max.	24 150 kPa	3500 psi	24 150 kPa	3500 psi
Min.	3100 kPa	450 psi	3100 kPa	450 psi
Interior Sound Level/SAE J919	70 dB(A)		70 dB(A)	
Electrical:				
System Size	24V		24V	
Std. Battery CCA @ 0° F	1125		1125	
Std. Alternator	80		80	
GENERAL DIMENSIONS:				
Height (to top of ROPS)	3308 mm	130.2"	3308 mm	130.2"
Overall Length	8436 mm	332.1"	8754 mm	344.6"
With Ripper and Pushplate	9930 mm	390.9"	10 136 mm	399.1"
Wheelbase	5915 mm	233.0"	6123 mm	241.1"
Blade Base	2511 mm	98.9"	2511 mm	98.9"
Overall Width (at top of front tires)	2491 mm	98.1"	2511 mm	98.9"
Standard Blade: Length	3658 mm	12'0"	3658 mm	12'0"
Height	610 mm	24.0"	610 mm	24.0"
Thickness	22 mm	0.87"	22 mm	0.87"
Lift Above Ground	427 mm	16.8"	480 mm	18.9"
Max. Shoulder Reach:***				
Frame Straight — Left	1742 mm	68.6"	1790 mm	70.5"
Frame Straight — Right	1905 mm	75"	1978 mm	77.9"
Fuel Tank Capacity	378 L	100 U.S. gal	416 L	110 U.S. gal

*Operating Weight — based on standard machine configuration with full fuel tank, coolant, lubricants and operator.

**Minimum Turning Radius — combining the use of articulated frame steering, front wheel steer and unlocked differential.

***Applicable for the standard blade with hydraulic sideshift and tip control. Maximum shoulder reach is obtainable to the right.

MODEL	140M		160M	
Base Power — Net	136 kW	183 hp	159 kW	213 hp
VHP Range — Net	136-155 kW	183-208 hp	159-170 kW	213-228 hp
VHP Plus Range — Net	136-174 kW	183-233 hp	159-185 kW	213-248 hp
Operating Weight*	16 581 kg	36,554 lb	16 820 kg	37,082 lb
Engine Model	C7 ACERT/C9 ACERT (AWD)		C9 ACERT	
Rated Engine RPM	2000		2000	
No. of Cylinders	6		6	
Displacement	7.2 L/8.8 L	439 in³ /537 in³	8.8 L	537 in³
Max. Torque	1159 N·m/1344 N·m	855 lb-ft/991 lb-ft	1237 N·m	912 lb-ft
No. of Speeds Forward/Reverse	8/6		8/6	
Top Speed: Forward	46.6 km/h	29.0 mph	47.4 km/h	29.5 mph
Reverse	36.8 km/h	22.9 mph	37.4 km/h	23.3 mph
Std. Tires — Front and Rear	14.00 24 (10 PR) (G-2)		14.00 24 (10 PR) (G-2)	
Front Axle/Steering:				
Oscillation Angle	32°		32°	
Wheel Lean Angle	18.0°		18.0°	
Steering Angle	47.5°		47.5°	
Articulation Angle	20°		20°	
Minimum Turning Radius**	7.6 m	24'10"	7.6 m	24'10"
No. Circle Support Shoes	6		6	
Hydraulics:				
Pump Type	Variable Piston		Variable Piston	
Max. Pump Flow	210 L/min	55.7 gpm	210 L/min	55.7 gpm
Tank Capacity	64 L	16.9 U.S. gal	64 L	16.9 U.S. gal
Implement Pressure: Max.	24 150 kPa	3500 psi	24 150 kPa	3500 psi
Min.	3100 kPa	450 psi	3100 kPa	450 psi
Interior Sound Level/SAE J919	70 dB(A)		70 dB(A)	
Electrical:				
System Size	24V		24V	
Std. Battery CCA @ 0° F	1125		1125	
Std. Alternator	80		80	
GENERAL DIMENSIONS:				
Height (to top of ROPS)	3308 mm	130.2"	3308 mm	130.2"
Overall Length	8754 mm	344.6"	8754 mm	344.6"
With Ripper and Pushplate	10 136 mm	399.1"	10 136 mm	399.1"
Wheelbase	6123 mm	241.1"	6123 mm	241.1"
Blade Base	2511 mm	98.9"	2511 mm	98.9"
Overall Width (at top of front tires)	2511 mm	98.9"	2511 mm	98.9"
Standard Blade: Length	3658 mm	12'0"	3658 mm	12'0"
Height	610 mm	24.0"	610 mm	24.0"
Thickness	22 mm	0.87"	22 mm	0.87"
Lift Above Ground	480 mm	18.9"	452 mm	17.8"
Max. Shoulder Reach:***				
Frame Straight — Left	1790 mm	70.5"	2090 mm	82.3"
Frame Straight — Right	1978 mm	77.9"	2278 mm	89.7"
Fuel Tank Capacity	416 L	110 U.S. gal	416 L	110 U.S. gal

*Operating Weight — based on standard machine configuration with full fuel tank, coolant, lubricants and operator.

**Minimum Turning Radius — combining the use of articulated frame steering, front wheel steer and unlocked differential.

***Applicable for the standard blade with hydraulic sideshift and tip control. Maximum shoulder reach is obtainable to the right.

MODEL	120M2		12M2	
Base Power — Net	108 kW	145 hp	129 kW	173 hp
VHP Plus Range — Net	108-141 kW	145-189 hp	129-166 kW	173-223 hp
Operating Weight*	15 887 kg	35,025 lb	16 849 kg	37,145 lb
Engine Model	C7.1 ACERT		C9.3 ACERT	
Rated Engine RPM	2100		2100	
No. of Cylinders	6		6	
Displacement	7.01 L	428 in³	9.3 L	567 in³
Max. Torque	939 N·m	693 lb·ft	1138 N·m	839 lb·ft
No. of Speeds Forward/Reverse	8/6		8/6	
Top Speed: Forward	45.7 km/h	28.4 mph	46.6 km/h	29.0 mph
Reverse	36.1 km/h	22.4 mph	36.8 km/h	22.9 mph
Std. Tires — Front and Rear	13.00 24 (12 PR) (G-2)		14.00R24 * (G-2)	
Front Axle/Steering:				
Oscillation Angle	32°		32°	
Wheel Lean Angle	18°		18°	
Steering Angle	47.5°		47.5°	
Articulation Angle	20°		20°	
Minimum Turning Radius**	7.3 m	24'1"	7.6 m	24'10"
No. Circle Support Shoes	6		6	
Hydraulics:				
Pump Type	Variable Piston		Variable Piston	
Max. Pump Flow	210 L/min	55.7 gpm	210 L/min	55.7 gpm
Tank Capacity	64 L	16.9 U.S. gal	64 L	16.9 U.S. gal
Implement Pressure: Max.	24 150 kPa	3500 psi	24 150 kPa	3500 psi
Min.	4200 kPa	609 psi	4200 kPa	609 psi
Interior Sound Level/SAE J919	71 dB(A)		71 dB(A)	
Electrical:				
System Size	24V		24V	
Std. Battery CCA @ 0° F	1125		1125	
Std. Alternator	150 amp		150 amp	
GENERAL DIMENSIONS:				
Height (to top of ROPS)	3308 mm	130.2"	3308 mm	130.2"
Overall Length	8820 mm	347.2"	8912 mm	350.9"
With Ripper and Pushplate	10 032 mm	395.0"	10 136 mm	399.1"
Wheelbase	5917 mm	233.0"	6123 mm	241.1"
Blade Base	2510 mm	98.8"	2552 mm	100.5"
Overall Width (at top of front tires)	2511 mm	98.9"	2511 mm	98.9"
Standard Blade: Length	3658 mm	12'0"	3658 mm	12'0"
Height	610 mm	24.0"	610 mm	24.0"
Thickness	22 mm	0.87"	22 mm	0.87"
Lift Above Ground	427 mm	16.8"	480 mm	18.9"
Max. Shoulder Reach:***				
Frame Straight — Left	1742 mm	68.6"	1790 mm	70.5"
Frame Straight — Right	1905 mm	75"	1978 mm	77.9"
Fuel Tank Capacity	378 L	100 U.S. gal	416 L	110 U.S. gal

***Operating Weight** — based on standard machine configuration with full fuel tank, coolant, lubricants and operator.

****Minimum Turning Radius** — combining the use of articulated frame steering, front wheel steer and unlocked differential.

***Applicable for the standard blade with hydraulic sideshift and tip control. Maximum shoulder reach is obtainable to the right.

MODEL	140M2		160M2	
Base Power — Net	144 kW	193 hp	159 kW	213 hp
VHP Plus Range — Net	144-181 kW	193-243 hp	159-196 kW	213-263 hp
Operating Weight*	17 198 kg	37,916 lb	17 438 kg	38,443 lb
Engine Model	C9.3 ACERT		C9.3 ACERT	
Rated Engine RPM	2100		2100	
No. of Cylinders	6		6	
Displacement	9.3 L	567 in ³	9.3 L	567 in ³
Max. Torque	1247 N·m	920 lb-ft	1355 N·m	1000 lb-ft
No. of Speeds Forward/Reverse	8/6		8/6	
Top Speed: Forward	46.6 km/h	29.0 mph	47.4 km/h	29.5 mph
Reverse	36.8 km/h	22.9 mph	37.4 km/h	23.3 mph
Std. Tires — Front and Rear	14.00R24 ★ (G-2)		14.00R24 ★ (G-2)	
Front Axle/Steering:				
Oscillation Angle	32°		32°	
Wheel Lean Angle	18.0°		18.0°	
Steering Angle	47.5°		47.5°	
Articulation Angle	20°		20°	
Minimum Turning Radius**	7.6 m	24'10"	7.6 m	24'10"
No. Circle Support Shoes	6		6	
Hydraulics:				
Pump Type	Variable Piston		Variable Piston	
Max. Pump Flow	210 L/min	55.7 gpm	210 L/min	55.7 gpm
Tank Capacity	64 L	16.9 U.S. gal	64 L	16.9 U.S. gal
Implement Pressure: Max.	24 150 kPa	3500 psi	24 150 kPa	3500 psi
Min.	4200 kPa	609 psi	4200 kPa	609 psi
Interior Sound Level/SAE J919	71 dB(A)		71 dB(A)	
Electrical:				
System Size	24V		24V	
Std. Battery CCA @ 0° F	1125		1125	
Std. Alternator	150		150	
GENERAL DIMENSIONS:				
Height (to top of ROPS)	3308 mm	130.2"	3308 mm	130.2"
Overall Length	8912 mm	350.9"	8912 mm	350.9"
With Ripper and Pushplate	10 136 mm	399.1"	10 136 mm	399.1"
Wheelbase	6123 mm	241.1"	6123 mm	241.1"
Blade Base	2552 mm	100.5"	2552 mm	100.5"
Overall Width (at top of front tires)	2511 mm	98.9"	2511 mm	98.9"
Standard Blade: Length	3658 mm	12'0"	4267 mm	14'0"
Height	610 mm	24.0"	610 mm	24.0"
Thickness	22 mm	0.87"	22 mm	0.87"
Lift Above Ground	480 mm	18.9"	452 mm	17.8"
Max. Shoulder Reach:***				
Frame Straight — Left	1790 mm	70.5"	2090 mm	82.3"
Frame Straight — Right	1978 mm	77.9"	2278 mm	89.7"
Fuel Tank Capacity	416 L	110 U.S. gal	416 L	110 U.S. gal

*Operating Weight — based on standard machine configuration with full fuel tank, coolant, lubricants and operator.

**Minimum Turning Radius — combining the use of articulated frame steering, front wheel steer and unlocked differential.

***Applicable for the standard blade with hydraulic sideshift and tip control. Maximum shoulder reach is obtainable to the right.

MODEL	12M3		140M3		160M3	
Base Power — Net	133 kW	179 hp	149 kW	200 hp	165 kW	221 hp
VHP Plus Range — Net	133-172 kW	179-231 hp	149-188 kW	200-252 hp	165-203 kW	221-272 hp
Operating Weight (Typical)*	16 974 kg	37,420 lb	17 323 kg	38,191 lb	17 563 kg	38,719 lb
Engine Model	C9.3 ACERT		C9.3 ACERT		C9.3 ACERT	
Rated Engine RPM	2000		2000		2000	
No. of Cylinders	6		6		6	
Displacement	9.3 L	567 in³	9.3 L	567 in³	9.3 L	567 in³
Max. Torque	1138 N·m	840 lb-ft	1247 N·m	920 lb-ft	1355 N·m	1000 lb-ft
No. of Speeds Forward/Reverse	8/6		8/6		8/6	
Top Speed: Forward	46.6 km/h	29.0 mph	46.6 km/h	29.0 mph	47.4 km/h	29.5 mph
Reverse	36.8 km/h	23.0 mph	36.8 km/h	23.0 mph	37.4 km/h	23.3 mph
Std. Tires — Front and Rear	14.00R24 * (G-2)		14.00R24 * (G-2)		14.00R24 * (G-2)	
Front Axle/Steering:						
Oscillation Angle	32°		32°		32°	
Wheel Lean Angle	18.0°		18.0°		18.0°	
Steering Angle	47.5°		47.5°		47.5°	
Articulation Angle	20°		20°		20°	
Minimum Turning Radius**	7.6 m	24'10"	7.6 m	24'10"	7.6 m	24'10"
No. Circle Support Shoes	6		6		6	
Hydraulics:						
Pump Type	Variable Piston		Variable Piston		Variable Piston	
Max. Pump Flow	210 L/min	55.7 gpm	210 L/min	55.7 gpm	210 L/min	55.7 gpm
Tank Capacity	64 L	16.9 U.S. gal	64 L	16.9 U.S. gal	64 L	16.9 U.S. gal
Implement Pressure: Max.	24 150 kPa	3500 psi	24 150 kPa	3500 psi	24 150 kPa	3500 psi
Min.	6100 kPa	885 psi	6100 kPa	885 psi	6100 kPa	885 psi
Interior Sound Level/SAE J919	71 dB(A)		71 dB(A)		71 dB(A)	
Electrical:						
System Size	24V		24V		24V	
Std. Battery CCA @ 0° F	1125		1125		1125	
Std. Alternator	150		150		150	
GENERAL DIMENSIONS:						
Height (to top of ROPS)	3308 mm	130.2"	3308 mm	130.2"	3308 mm	130.2"
Overall Length	8912 mm	350.9"	8912 mm	350.9"	8912 mm	350.9"
With Ripper and Pushplate	10 136 mm	399.1"	10 136 mm	399.1"	10 136 mm	399.1"
Wheelbase	6123 mm	241.1"	6123 mm	241.1"	6123 mm	241.1"
Blade Base	2552 mm	100.5"	2552 mm	100.5"	2552 mm	100.5"
Overall Width						
(at top of front tires)	2511 mm	98.9"	2511 mm	98.9"	2511 mm	98.9"
Standard Blade: Length	3658 mm	12'0"	3658 mm	12'0"	4267 mm	14'0"
Height	610 mm	24.0"	610 mm	24.0"	610 mm	24.0"
Thickness	22 mm	0.87"	22 mm	0.87"	22 mm	0.87"
Lift Above Ground	480 mm	18.9"	480 mm	18.9"	480 mm	18.9"
Max. Shoulder Reach:***						
Frame Straight — Left	1790 mm	70.5"	1790 mm	70.5"	2090 mm	82.3"
Frame Straight — Right	1978 mm	77.9"	1978 mm	77.9"	2278 mm	89.7"
Fuel Tank Capacity	394 L	104 U.S. gal	394 L	104 U.S. gal	394 L	104 U.S. gal
Diesel Exhaust Fluid Capacity	22.0 L	5.8 U.S. gal	22.0 L	5.8 U.S. gal	22.0 L	5.8 U.S. gal

***Operating Weight** — based on standard machine configuration with full fuel tank, coolant, lubricants and operator.

****Minimum Turning Radius** — combining the use of articulated frame steering, front wheel steer and unlocked differential.

***Applicable for the standard blade with hydraulic sideshift and tip control. Maximum shoulder reach is obtainable to the right.

MODEL	16M3		18M3	
Max. Torque:				
Tier 4 Final ¹	1771 N·m	1306 lb-ft	1771 N·m	1306 lb-ft
Tier 2 and Tier 3 Equivalent ²	1721 N·m	1270 lb-ft	1721 N·m	1270 lb-ft
No. of Speeds Forward/Reverse		8/6		8/6
Top Speed: Forward	51.7 km/h	32.1 mph	51.7 km/h	32.1 mph
Reverse	40.8 km/h	25.3 mph	40.8 km/h	25.3 mph
Std. Tires — Front and Rear		23.5R25		23.5R25
Front Axle/Steering:				
Oscillation Angle		35°		35°
Wheel Lean Angle — Left/Right		18°/17°		18°/17°
Steering Angle		47.5°		47.5°
Articulation Angle		20°		20°
Minimum Turning Radius**	9.3 m	30'6"	9.3 m	30'6"
No. Circle Support Shoes		6		6
Hydraulics:				
Pump Type		Variable Piston		Variable Piston
Max. Pump Flow	280 L/min	74 gpm	280 L/min	74 gpm
Tank Capacity	70 L	18.5 U.S. gal	70 L	18.5 U.S. gal
Implement Pressure: Max.	24 750 kPa	3590 psi	24 750 kPa	3590 psi
Min.	3400 kPa	493 psi	3400 kPa	493 psi
Interior Sound Level/SAE J919:				
Tier 4 Final/EU Certified ¹		71 dB(A)		71 dB(A)
Tier 2 and Tier 3 Equivalent ²		72 dB(A)		72 dB(A)
Electrical:				
System Size		24V		24V
Std. Battery CCA @ 0° F		1400		1400
Std. Alternator		150		150
GENERAL DIMENSIONS:				
Height (to top of ROPS)	3719 mm	146.4"	3719 mm	146.4"
Overall Length	10 593 mm	417"	10 593 mm	417"
With Ripper and Pushplate	12 051 mm	474.4"	12 051 mm	474.4"
Wheelbase	7365 mm	290"	7365 mm	290"
Blade Base	3066 mm	120.7"	3066 mm	120.7"
Overall Width (at top of front tires)	3411 mm	134.3"	3411 mm	134.3"
Standard Blade: Length	4877 mm	16'0"	5511 mm	18'0"
Height	787 mm	31.0"	787 mm	31.0"
Thickness	25 mm	1.0"	25 mm	1.0"
Lift Above Ground	400 mm	15.7"	400 mm	15.7"
Max. Shoulder Reach:***				
Frame Straight — Left	2311 mm	91"	2605 mm	102.6"
Frame Straight — Right	2311 mm	91"	2605 mm	102.6"
Fuel Tank Capacity	496 L	131 U.S. gal	496 L	131 U.S. gal

***Operating Weight** — based on standard machine configuration with full fuel tank, coolant, lubricants and operator.

****Minimum Turning Radius** — combining the use of articulated frame steering, front wheel steer and unlocked differential.

***Applicable for the standard blade with hydraulic sideshift and tip control. Maximum shoulder reach is obtainable to the right.

¹ Meets Tier 4 Final/Stage IV/Japan 2014 (Tier 4 Final) emission standards.

² Meets Tier 2/Stage II/Japan 2001 (Tier 2) equivalent and Tier 3/Stage IIIA/Japan 2006 (Tier 3) equivalent emission standards.

MODEL	14M		24M	
Base Power — Net	193 kW	259 hp	397 kW	533 hp
VHP Range — Net	193-205 kW	259-275 hp	—	—
VHP Plus Range — Net	193-221 kW	259-297 hp	—	—
Operating Weight*	21 423 kg	47,230 lb	62 726 kg	138,287 lb
Engine Model	C11 ACERT		C18 ACERT	
Rated Engine RPM	1800		1800	
No. of Cylinders	6		6	
Displacement	11.1 L	677 in³	18.1 L	1104.5 in³
Max. Torque	1422 N·m	1049 lb-ft	2713 N·m	2001 lb-ft
No. of Speeds Forward/Reverse	8/6		6/3	
Top Speed: Forward	50.4 km/h	31.3 mph	43.4 km/h	27.0 mph
Reverse	39.8 km/h	24.7 mph	41.6 km/h	25.8 mph
Std. Tires — Front and Rear	16R24		29.5R29	
Front Axle/Steering:				
Oscillation Angle	32°		32°	
Wheel Lean Angle	17.1°		18.0°	
Steering Angle	47.5°		47.5°	
Articulation Angle	20°		25°	
Minimum Turning Radius**	7.9 m	25'11"	12.4 m	40'9"
No. Circle Support Shoes	6		6	
Hydraulics:				
Pump Type	Variable Piston		Variable Piston	
Max. Pump Flow	280 L/min	74 gpm	550 L/min	145 gpm
Tank Capacity	64 L	16.9 U.S. gal	135 L	36 U.S. gal
Implement Pressure: Max.	24 150 kPa	3500 psi	24 150 kPa	3500 psi
Min.	3100 kPa	450 psi	3100 kPa	450 psi
Interior Sound Level/SAE J919	70 dB(A)		74 dB(A)	
Electrical:				
System Size	24V		24V	
Std. Battery CCA @ 0° F	1125		1500	
Std. Alternator	80		150	
GENERAL DIMENSIONS:				
Height (to top of ROPS)	3535 mm	139.2"	4452 mm	175.3"
Overall Length	9349 mm	368.1"	14 194 mm	558.8"
With Ripper and Pushplate	10 896 mm	429.0"	16 102 mm	633.9"
Wheelbase	6559 mm	258.0"	10 278 mm	404.6"
Blade Base	2840 mm	111.8"	4048 mm	159.4"
Overall Width (at top of front tires)	2801 mm	110.3"	4280 mm	168.5"
Standard Blade: Length	4267 mm	14'0"	7315 mm	24'0"
Height	686 mm	27.0"	1025 mm	40.0"
Thickness	25 mm	1.0"	50 mm	2.0"
Lift Above Ground	419 mm	16.5"	634 mm	25.0"
Max. Shoulder Reach:***				
Frame Straight — Left	2169 mm	85.4"	3222 mm	126.9"
Frame Straight — Right	2279 mm	89.7"	3228 mm	127.1"
Fuel Tank Capacity	492 L	130 U.S. gal	1326 L	350 U.S. gal

*Operating Weight — based on standard machine configuration with full fuel tank, coolant, lubricants and operator. 24M includes ripper.

**Minimum Turning Radius — combining the use of articulated frame steering, front wheel steer and unlocked differential.

***Applicable for the standard blade with hydraulic sideshift and tip control. Maximum shoulder reach is obtainable to the right.

TRAVEL SPEEDS @ MAXIMUM RPM WITH STD. TIRES (M/M2/M3 SERIES)

Gear		1		2		3		4		5		6		7		8	
		km/h	mph	km/h	mph	km/h	mph	km/h	mph	km/h	mph	km/h	mph	km/h	mph	km/h	mph
120M	Forward	4.1	2.6	5.6	3.5	8.2	5.1	11.2	7.0	17.5	10.8	23.7	14.8	32.7	20.3	47.5	29.5
	Reverse	3.3	2.0	6.1	3.8	8.9	5.5	13.8	8.6	25.8	16.0	37.5	23.3	—	—	—	—
120M2	Forward	4.0	2.5	5.4	3.4	7.8	4.8	10.8	6.7	16.8	10.4	22.8	14.2	31.4	19.5	45.7	28.4
	Reverse	3.1	1.9	5.9	3.9	8.5	5.3	13.2	8.2	24.8	15.4	36.1	22.4	—	—	—	—
12M	Forward	4.0	2.5	5.5	3.4	8.0	5.0	11.0	6.8	17.1	10.6	23.3	14.5	32.0	19.9	46.6	29.0
	Reverse	3.2	2.0	6.0	3.7	8.7	5.4	13.5	8.4	25.3	15.7	36.8	22.9	—	—	—	—
12M2	Forward	4.1	2.5	5.5	3.4	8.0	5.0	11.0	6.9	17.1	10.6	23.3	14.5	32.0	19.9	46.6	29.0
	Reverse	3.2	2.0	6.0	3.7	8.7	5.4	13.5	8.4	25.3	15.7	36.8	22.9	—	—	—	—
12M3	Forward	4.1	2.5	5.5	3.4	8.0	5.0	11.0	6.9	17.1	10.6	23.3	14.5	32.0	19.9	46.6	29.0
	Reverse	3.2	2.0	6.0	3.7	8.7	5.4	13.5	8.4	25.3	15.7	36.8	23.0	—	—	—	—
140M	Forward	4.0	2.5	5.5	3.4	8.0	5.0	11.0	6.9	17.1	10.6	23.3	14.5	32.0	19.9	46.6	29.0
	Reverse	3.2	2.0	6.0	3.7	8.7	5.4	13.5	8.4	25.3	15.7	36.8	22.9	—	—	—	—
140M2	Forward	4.1	2.5	5.5	3.4	8.0	5.0	11.0	6.9	17.1	10.6	23.3	14.5	32.0	19.9	46.6	29.0
	Reverse	3.2	2.0	6.0	3.7	8.7	5.4	13.5	8.4	25.3	15.7	36.8	22.9	—	—	—	—
140M3	Forward	4.1	2.5	5.5	3.4	8.0	5.0	11.0	6.9	17.1	10.6	23.3	14.5	32.0	19.9	46.6	29.0
	Reverse	3.2	2.0	6.0	3.7	8.7	5.4	13.5	8.4	25.3	15.7	36.8	23.0	—	—	—	—
160M	Forward	4.1	2.5	5.6	3.5	8.1	5.0	11.2	7.0	17.4	10.8	23.7	14.7	32.6	20.3	47.4	29.5
	Reverse	3.3	2.0	6.1	3.8	8.8	5.5	13.7	8.5	25.7	16.0	37.4	23.3	—	—	—	—
160M2	Forward	4.1	2.6	5.6	3.5	8.1	5.1	11.2	7.0	17.4	10.8	23.7	14.7	32.6	20.3	47.4	29.5
	Reverse	3.3	2.0	6.1	3.8	8.9	5.5	13.7	8.5	25.7	16.0	37.4	23.3	—	—	—	—
160M3	Forward	4.1	2.6	5.6	3.5	8.1	5.1	11.2	7.0	17.4	10.8	23.7	14.7	32.6	20.3	47.4	29.5
	Reverse	3.3	2.0	6.1	3.8	8.8	5.5	13.7	8.5	25.7	16.0	37.4	23.3	—	—	—	—
16M3	Forward	4.5	2.8	6.1	3.8	8.9	5.5	12.3	7.6	19.0	11.8	25.8	16.0	35.5	22.0	51.7	32.1
	Reverse	3.6	2.2	6.6	4.1	9.7	6.0	15.0	9.3	28.0	17.4	40.8	25.3	—	—	—	—
18M3	Forward	4.5	2.8	6.1	3.8	8.9	5.5	12.3	7.6	19.0	11.8	25.8	16.0	35.5	22.0	51.7	32.1
	Reverse	3.6	2.2	6.6	4.1	9.7	6.0	15.0	9.3	28.0	17.4	40.8	25.3	—	—	—	—
14M	Forward	4.4	2.7	6.0	3.7	8.7	5.4	12.0	7.4	18.5	11.5	25.1	15.6	34.6	21.5	50.4	31.3
	Reverse	3.5	2.2	6.5	4.0	9.4	5.9	14.6	9.1	27.3	17.0	39.8	24.7	—	—	—	—
24M	Forward	3.7	2.3	5.7	3.6	9.7	6.0	15.1	9.4	28.0	17.4	43.4	27.0	—	—	—	—
	Reverse	5.5	3.4	14.5	9.0	41.6	25.8	—	—	—	—	—	—	—	—	—	—

NOTE: 120M speeds were calculated with a 628 mm (24.7") tire at 2000 rpm rated speed.
 120M2 speeds were calculated with a 620 mm (24.4") tire at high idle, 2150 rpm.
 12M2-160M2 speeds were calculated with a 655 mm (25.8") tire at high idle, 2150 rpm.
 12M3-160M3 speeds were calculated with a 655 mm (25.8") tire at 2000 rpm rated speed.

TRAVEL SPEEDS @ MAXIMUM RPM WITH STD. TIRES (K/K2 SERIES)

Gear		1		2		3		4		5		6		7		8	
		km/h	mph	km/h	mph	km/h	mph	km/h	mph	km/h	mph	km/h	mph	km/h	mph	km/h	mph
120K	Forward	4.1	2.5	5.5	3.4	8.0	5.0	11.1	6.9	17.5	10.8	23.7	14.8	32.7	20.3	47.5	29.5
	Reverse	3.2	2.0	6.0	3.7	8.7	5.4	13.8	8.6	25.8	16.0	37.5	23.3	—	—	—	—
120K2	Forward	4.1	2.5	5.5	3.4	8.0	5.0	11.1	6.9	17.5	10.8	23.7	14.8	32.7	20.3	47.5	29.5
	Reverse	3.2	2.0	6.0	3.7	8.7	5.4	13.8	8.6	25.8	16.0	37.5	23.3	—	—	—	—
12K	Forward	4.0	2.5	5.4	3.4	7.9	4.9	10.9	6.8	17.1	10.6	23.3	14.5	32.0	19.9	46.8	29.0
	Reverse	3.2	2.0	5.9	3.7	8.6	5.3	13.5	8.4	25.3	15.7	36.8	22.9	—	—	—	—
140K	Forward	4.1	2.5	5.5	3.4	8.0	5.0	11.0	6.9	17.4	10.8	23.6	14.7	32.5	20.2	47.3	29.4
	Reverse	3.2	2.0	6.0	3.7	8.7	5.4	13.7	8.5	25.7	16.0	37.4	23.2	—	—	—	—
140K2	Forward	4.1	2.5	5.5	3.4	8.0	5.0	11.0	6.9	17.4	10.8	23.6	14.7	32.5	20.2	47.3	29.4
	Reverse	3.2	2.0	6.0	3.7	8.7	5.4	13.7	8.5	25.7	16.0	37.4	23.2	—	—	—	—
160K	Forward	4.1	2.5	5.5	3.4	8.1	5.0	11.1	6.9	17.2	10.7	23.4	14.6	32.2	20.0	46.9	29.1
	Reverse	3.2	2.0	6.0	3.7	8.8	5.4	13.6	8.4	25.4	15.8	37.0	23.0	—	—	—	—

ALL WHEEL DRIVE (AWD)	120M/120M2, 12M2/M3, 140M/M2/M3, 160M/M2/M3	
Working Range:		
Forward Gears	gears 1-7	
Reverse Gears	gears 1-5	
Pump Type	Variable Displacement Axial Piston Pumps (2)	
Motor Type	Variable Displacement Axial Piston Motors (2)	
Front Wheel Gear Reduction	Double Planetary Reduction	
Maximum Pump Flow (each pump)	125 L/min	33 gpm
Front Wheel Torque	13 998 N·m	10,325 lb-ft
Control Type	Speed control with closed-loop feedback	

The optional AWD system utilizes dedicated left and right pumps for precise hydraulic control.

Hydrostatic Mode disengages the transmission and provides hydraulic power to the front wheels only-ininitely variable to 8 km/h (5 mph).

Exclusive AWD Steering Compensation adjusts outside front tire speed up to 50% faster than the inside tire.

Operating Pressure depends on engine speed, gear selection and operating conditions.

M10 – MID MOUNT SCARIFIER	120M/M2, 12M/M2/M3, 140M/M2/M3, 160M/M2/M3			
Type	V-type		Straight type*	
Working Width	1184 mm	46.6"	1800 mm	71"
Depth (Max.)	292 mm	11.5"	317 mm	12.5"
Number of Shank Holders	11		17	
Spacing	116 mm	4.6"	111 mm	4.4"

*Available on M Series Global Versions only.

FRONT MOUNT SCARIFIER	120M/M2, 12M/M2/M3, 140M/M2/M3, 160M/M2/M3			
Type	V-type			
Working Width	1205 mm			47.4"
Depth (Max.)	467 mm			18.4"
Number of Shank Holders	11			
Spacing	116 mm			4.6"

MOTOR GRADER/RIPPER	120M		120M2		12M		12M2	
Parallelogram — Rear Mounted	Ripper/Scarifier		Ripper/Scarifier		Ripper/Scarifier		Ripper/Scarifier	
Tire Size (Std.)	13.00 24		13.00 24		14R24		14.00R24	
Front and Rear	12PR (G-4)		12PR (G-2)		12PR (G-2)		★ (G-2)	
Scarifier								
Maximum Digging Depth	267 mm	10.5"	267 mm	10.5"	267 mm	10.5"	267 mm	10.5"
Number of Pockets	9		9		9		9	
Spacing	267 mm	10.5"	267 mm	10.5"	267 mm	10.5"	267 mm	10.5"
Ripper Shank								
Maximum Digging Depth	428 mm	16.9"	428 mm	16.9"	428 mm	16.9"	428 mm	16.9"
Maximum Reach at Ground Line	973 mm	38.3"	973 mm	38.3"	973 mm	38.3"	973 mm	38.3"
Maximum Ground Clearance under Tip (shank pinned in bottom hole)	502 mm	19.8"	502 mm	19.8"	502 mm	19.8"	502 mm	19.8"
Maximum Ramp Angle, Ripper Up, Shanks in Working Position (shank pinned in bottom hole)	14.5°		13.5°		14.5°		15.0°	
Shank Section	59 × 138 mm 2.3" × 5.4"		59 × 138 mm 2.3" × 5.4"		59 × 138 mm 2.3" × 5.4"		59 × 138 mm 2.3" × 5.4"	
Ripper Beam								
Overall Width	2.31 m	7'7"	2.31 m	7'7"	2.31 m	7'7"	2.31 m	7'7"
Height	152 mm	6.0"	152 mm	6.0"	152 mm	6.0"	152 mm	6.0"
Length	230 mm	9.1"	230 mm	9.1"	230 mm	9.1"	230 mm	9.1"
Number of Pockets	5		5		5		5	
Pocket Spacing:								
Inside	533 mm	1'9"	533 mm	1'9"	533 mm	1'9"	533 mm	1'9"
Middle	533 mm	1'9"	533 mm	1'9"	533 mm	1'9"	533 mm	1'9"
Outside	533 mm	1'9"	533 mm	1'9"	533 mm	1'9"	533 mm	1'9"
Shank Gauge	2.13 m	7'0"	2.13 m	7'0"	2.13 m	7'0"	2.13 m	7'0"
Installed Weights:								
Ripper with Standard Shank	1100 kg	2425 lb	1100 kg	2425 lb	1111 kg	2449 lb	1086 kg	2394 lb
Each Additional Shank	31 kg	68 lb	31 kg	68 lb	31 kg	68 lb	31 kg	68 lb
Ripper Forces:								
Penetration Force	8454 kg	18,638 lb	9106 kg	20,075 lb	9189 kg	20,258 lb	9440 kg	20,812 lb
Pryout Force	10 024 kg	22,099 lb	10 616 kg	23,404 lb	11 635 kg	25,651 lb	12 430 kg	27,403 lb

MOTOR GRADER/RIPPER	12M3		140M		140M2		140M3	
Parallelogram — Rear Mounted	Ripper/Scarifier		Ripper/Scarifier		Ripper/Scarifier		Ripper/Scarifier	
Tire Size (Std.)	14.00R24		14.00-24		14.00R24		14.00R24	
Front and Rear	★ (G-2)		10PR (G-2)		★ (G-2)		★ (G-2)	
Scarifier								
Maximum Digging Depth	267 mm	10.5"	261 mm	10.3"	265 mm	10.4"	265 mm	10.4"
Number of Pockets	9		9		9		9	
Spacing	267 mm	10.5"	267 mm	10.5"	267 mm	10.5"	267 mm	10.5"
Ripper Shank								
Maximum Digging Depth	428 mm	16.9"	422 mm	16.6"	426 mm	16.8"	426 mm	16.8"
Maximum Reach at Ground Line	973 mm	38.3"	973 mm	38.3"	973 mm	38.3"	973 mm	38.3"
Maximum Ground Clearance under Tip (shank pinned in bottom hole)	502 mm	19.8"	508 mm	20"	488 mm	19.2"	488 mm	19.2"
Maximum Ramp Angle, Ripper Up, Shanks in Working Position (shank pinned in bottom hole)	15.0°		15.3°		15.0°		15.0°	
Shank Section	59 × 138 mm 2.3" × 5.4"		59 × 138 mm 2.3" × 5.4"		59 × 138 mm 2.3" × 5.4"		59 × 138 mm 2.3" × 5.4"	
Ripper Beam								
Overall Width	2.31 m	7'7"	2.31 m	7'7"	2.31 m	7'7"	2.31 m	7'7"
Height	152 mm	6.0"	152 mm	6.0"	152 mm	6.0"	152 mm	6.0"
Length	230 mm	9.1"	230 mm	9.1"	230 mm	9.1"	230 mm	9.1"
Number of Pockets	5		5		5		5	
Pocket Spacing:								
Inside	533 mm	1'9"	533 mm	1'9"	533 mm	1'9"	533 mm	1'9"
Middle	533 mm	1'9"	533 mm	1'9"	533 mm	1'9"	533 mm	1'9"
Outside	533 mm	1'9"	533 mm	1'9"	533 mm	1'9"	533 mm	1'9"
Shank Gauge	2.13 m	7'0"	2.13 m	7'0"	2.13 m	7'0"	2.13 m	7'0"
Installed Weights:								
Ripper with Standard Shank	1086 kg	2394 lb	1111 kg	2449 lb	1086 kg	2394 lb	1086 kg	2394 lb
Each Additional Shank	31 kg	68 lb	31 kg	68 lb	31 kg	68 lb	31 kg	68 lb
Ripper Forces:								
Penetration Force	9440 kg	20,812 lb	9440 kg	20,812 lb	9440 kg	20,812 lb	9440 kg	20,812 lb
Pryout Force	12 607 kg	27,794 lb	12 147 kg	26,780 lb	12 943 kg	28,534 lb	12 607 kg	27,794 lb

MOTOR GRADER/RIPPER	160M		160M2		160M3	
Parallelogram — Rear Mounted	Ripper/ Scarifier		Ripper/ Scarifier		Ripper/ Scarifier	
Tire Size (Std.)	14.00-24		14.00R24		14.00R24	
Front and Rear	10PR (G-2)		★ (G-2)		★ (G-2)	
Scarifier						
Maximum Digging Depth	261 mm	10.3"	265 mm	10.4"	265 mm	10.4"
Number of Pockets	9		9		9	
Spacing	267 mm	10.5"	267 mm	10.5"	267 mm	10.5"
Ripper Shank						
Maximum Digging Depth	422 mm	16.6"	426 mm	16.8"	426 mm	16.8"
Maximum Reach at Ground Line	973 mm	38.3"	973 mm	38.3"	973 mm	38.3"
Maximum Ground Clearance under Tip (shank pinned in bottom hole)	508 mm	20"	488 mm	19.2"	488 mm	19.2"
Maximum Ramp Angle, Ripper Up, Shanks in Working Position (shank pinned in bottom hole)	15.3°		15.0°		15.0°	
Shank Section	59 × 138 mm 2.3" × 5.4"		59 × 138 mm 2.3" × 5.4"		59 × 138 mm 2.3" × 5.4"	
Ripper Beam						
Overall Width	2.31 m	7'7"	2.31 m	7'7"	2.31 m	7'7"
Height	152 mm	6.0"	152 mm	6.0"	152 mm	6.0"
Length	230 mm	9.1"	230 mm	9.1"	230 mm	9.1"
Number of Pockets	5		5		5	
Pocket Spacing:						
Inside	533 mm	1'9"	533 mm	1'9"	533 mm	1'9"
Middle	533 mm	1'9"	533 mm	1'9"	533 mm	1'9"
Outside	533 mm	1'9"	533 mm	1'9"	533 mm	1'9"
Shank Gauge	2.13 m	7'0"	2.13 m	7'0"	2.13 m	7'0"
Installed Weights:						
Ripper with Standard Shank	1111 kg	2449 lb	1086 kg	2394 lb	1086 kg	2394 lb
Each Additional Shank	31 kg	68 lb	31 kg	68 lb	31 kg	68 lb
Ripper Forces:						
Penetration Force	9440 kg	20,812 lb	9440 kg	20,812 lb	9440 kg	20,812 lb
Pryout Force	12 861 kg	28,354 lb	13 656 kg	30,106 lb	12 924 kg	28,493 lb

MOTOR GRADER/RIPPER	16M3		18M3	
Parallelogram — Rear Mounted	Ripper		Ripper	
Tire Size (Std.)	23.5-25		23.5-25	
Front and Rear	12PR (G-2)		12PR (G-2)	
Ripper Shank				
Maximum Digging Depth	452 mm	17.8"	452 mm	17.8"
Maximum Reach at Ground Line	1500 mm	4'11"	1500 mm	4'11"
Maximum Ground Clearance under Tip (shank pinned in bottom hole)	673 mm	2'2.5"	673 mm	2'2.5"
Maximum Ramp Angle, Ripper Up, Shanks in Working Position (shank pinned in bottom hole)	14.3°		14.3°	
Shank Section	76 × 178 mm 3" × 7"		76 × 178 mm 3" × 7"	
Ripper Beam				
Overall Width	2.98 m	9'9"	2.98 m	9'9"
Height	214 mm	8.4"	214 mm	8.4"
Length	254 mm	10"	254 mm	10"
Number of Pockets	7		7	
Pocket Spacing:				
Inside	500 mm	1'8"	500 mm	1'8"
Middle	445 mm	17.5"	445 mm	17.5"
Outside	445 mm	17.5"	445 mm	17.5"
Installed Weights:				
Ripper with Standard Shank	2198 kg	4836 lb	2198 kg	4836 lb
Each Additional Shank	68 kg	150 lb	68 kg	150 lb
Ripper Forces:				
Penetration Force	13 749 kg	30,311 lb	13 749 kg	30,311 lb
Pryout Force	19 822 kg	43,700 lb	19 822 kg	43,700 lb

MOTOR GRADER/RIPPER	14M		24M	
Parallelogram — Rear Mounted	Ripper		Ripper	
Tire Size (Std.)	16.00-24		29.5-29	
Front and Rear	16PR (G-2)		28PR	
Ripper Shank				
Maximum Digging Depth	402 mm	15.8"	490 mm	1'7.3"
Maximum Reach at Ground Line	1061 mm	41.8"	1165 mm	3'9.9"
Maximum Ground Clearance under Tip (shank pinned in bottom hole)	635 mm	25"	739 mm	2'5.1"
Maximum Ramp Angle, Ripper Up, Shanks in Working Position (shank pinned in bottom hole)	15.3°		12.5°	
Shank Section	59 × 138 mm 2.3" × 5.4"		76 × 178 mm 3" × 7"	
Ripper Beam				
Overall Width	2.60 m	8'6"	3.91 m	12'10"
Height	165 mm	6.5"	216 mm	8.5"
Length	211 mm	8.3"	254 mm	10"
Number of Pockets	7		7	
Pocket Spacing:				
Inside	472 mm	1'7"	593 mm	1'11.4"
Middle	373 mm	1'3"	604 mm	1'11.8"
Outside	373 mm	1'3"	604 mm	1'11.8"
Shank Gauge	2.44 m	8'0"	—	
Installed Weights:				
Ripper with Standard Shank	1492 kg	3289 lb	2812 kg	6186 lb
Each Additional Shank	31 kg	68 lb	68 kg	150 lb
Ripper Forces:				
Penetration Force	12 102 kg	26,680 lb	13 601 kg	29,985 lb
Pryout Force	12 618 kg	27,818 lb	18 621 kg	41,052 lb

PRODUCTION

The motor grader is used in a variety of applications in a variety of industries. Therefore, there are many ways to measure its operating capacity, or production. One method expresses a motor grader's production in relation to the area covered by the moldboard.

Formula:

$$A = S \times (L_e - L_o) \times 1000 \times E \text{ (Metric)}$$

$$A = S \times (L_e - L_o) \times 5280 \times E \text{ (English)}$$

where A: Hourly operating area (m²/h or ft²/h)

S: Operating speed (km/h or mph)

L_e: Effective blade length (m or ft)

L_o: Width of overlap (m or ft)

E: Job efficiency

Operating Speeds:

Typical operating speeds by application

Finish Grading:	0-4 km/h	(0-2.5 mph)
Heavy Blading:	0-9 km/h	(0-6 mph)
Ditch Repair:	0-5 km/h	(0-3 mph)
Ripping:	0-5 km/h	(0-3 mph)
Road Maintenance:	5-16 km/h	(3-9.5 mph)
Haul Road Maintenance:	5-16 km/h	(3-9.5 mph)
Snow Plowing:	7-21 km/h	(4-13 mph)
Snow Winging:	15-28 km/h	(9-17 mph)

Effective Blade Length:

Since the moldboard is usually angled when moving material, an effective blade length must be computed to account for this angle. This is the actual width of material swept by the moldboard.

NOTE: Angles are measured as shown below. The effective length becomes shorter as the angle increases.

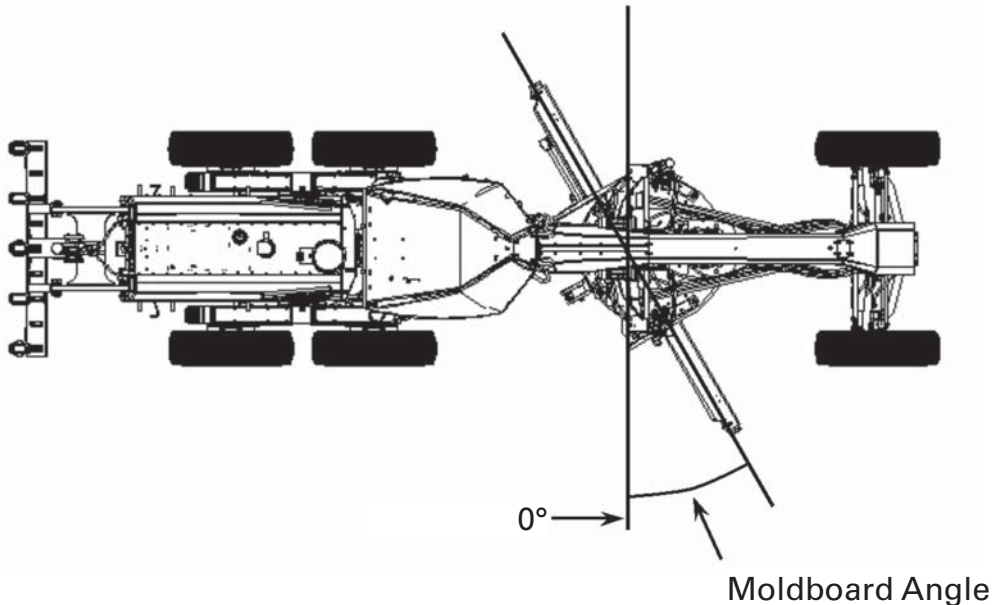

Moldboard Length, m (ft)	Effective Length, m (ft) 30 degree blade angle	Effective Length, m (ft) 45 degree blade angle
3.658 (12)	3.17 (10.4)	2.59 (8.5)
4.267 (14)	3.70 (12.1)	3.02 (9.9)
4.877 (16)	4.22 (13.9)	3.45 (11.3)
7.315 (24)	6.33 (20.8)	5.17 (17.0)

For other blade lengths and carry angles:
 Effective length = COS [Radians (Blade L)] 3 Blade Length

Width of Overlap:

The width of overlap is generally 0.6 m (2.0 ft). This overlap accounts for the need to keep the tires out of the windrow on the return pass.

Job Efficiency:

Job efficiencies vary based on job conditions, operator skill, etc.

A good estimation for efficiency is approximately 0.70 to 0.85, but actual operating conditions should be used to determine the best value.

Example problem:

A Cat motor grader with a 3.66 m (12 ft) moldboard is performing road maintenance on a township road. The machine is working at an average speed of 13 km/h (8 mph) with a moldboard carry angle of 30 degrees. What is the motor grader’s production based on coverage area?

Note: Due to the long passes involved in road maintenance — fewer turnarounds — a higher job efficiency of 0.90 is chosen.

Solution:

From the table, the effective blade length is 3.17 m (10.4 ft).

Metric

$$\begin{aligned} \text{Production, A} &= 13 \text{ km/h} \times (3.17 \text{ m} - 0.6 \text{ m}) \times \\ &1000 \times 0.90 \\ &= \mathbf{30\ 069 \text{ m}^2/\text{hr} \text{ (3.07 hectares/hr)}} \end{aligned}$$

English

$$\begin{aligned} \text{Production, A} &= 8 \text{ mph} \times (10.4 \text{ ft} - 2.0 \text{ ft}) \times \\ &5280 \times 0.90 \\ &= \mathbf{319,334 \text{ ft}^2/\text{hr} \text{ (7.33 acres/hr)}} \end{aligned}$$

To pinpoint the theoretical number of motor graders required to properly maintain your haul roads, based on your specific mining applications, please download the haul road maintenance calculator on <https://catminer.cat.com>.

Haul road maintenance impacts cycle time, tire, frame and drive train components, safety and ultimately your cost per ton. To achieve optimal truck productivity, your haul roads must be properly maintained.

- Moderate:
- Road Maintenance
 - Pad Cleaning
 - Rock Clearing
 - Shoulder Sweeping

- Difficult:
- Ripping
 - Spreading Dump Material
 - Road Profiling/Reshaping

BLADE PULL

This specification is also known as drawbar pull. This spec can be calculated as follows:

Variables:

Rear weight of machine = Wr

Tire traction coefficient = T (Look up the table entitled “Coefficient of Traction Factors”)

$$Wr \times T = \text{Blade Pull}$$

Example problem:

Calculate the blade pull for a 140M Global Version machine operating in a quarry pit...

Metric

RW = 10 501 kg

T = 0.65

$$10\,501 \times 0.65 = 6825.65$$

English

RW = 23,151 lb

T = 0.65

$$23,151 \times 0.65 = 15,048.15$$

BLADE DOWN PRESSURE

This spec can be calculated as follows:

Variables:

Blade to front axle length = BA

Wheel base length = WB

Weight on front wheels = FW

Blade down pressure = BD

$$\frac{WB}{(WB - BA)} \times FW = BD$$

Example problem:

Calculate the blade down pressure for a 140M Global Version machine...

Metric

BA = 2565 mm FW = 4223 kg

WB = 6086 mm BD = ?

$$\frac{6086}{(6086 - 2565)} \times 4223 = 7299 \text{ kg}$$

English

BA = 101 in

FW = 9310 lb

WB = 240 in

BD = ?

$$\frac{240}{(240 - 101)} \times 9310 = 16,075 \text{ lb}$$

This specification is only a minor indicator of a motor grader’s productivity. It alone gives no measure of overall machine productivity. When considering motor grader production you need an optimum balance between the machine’s front and rear weights. If a machine has too much weight on the front axle, it might have a high blade down pressure spec. It will, however, lack the essential rear weight and traction needed to push through the load. Too much weight in the rear and it will not have the necessary weight in the front during heavy cuts to maintain proper steering control.

Cat machines are built with this optimum balance in mind. A Cat motor grader is engineered with the proper weight distribution necessary for maximum productivity.

Effective Blade Length*

		Moldboard							
		3.66 m (12')		4.27 m (14')		4.88 m (16')		7.32 m (24')	
Angle°		m	ft	m	ft	m	ft	m	ft
	0°	3.66	12.00	4.27	14.00	4.88	16.00	7.32	24.00
	5°	3.64	11.95	4.25	13.95	4.86	15.94	7.29	23.91
	10°	3.60	11.82	4.20	13.79	4.80	15.76	7.21	23.64
	15°	3.53	11.59	4.12	13.52	4.71	15.45	7.07	23.18
	20°	3.44	11.28	4.01	13.16	4.58	15.04	6.87	22.55
	25°	3.32	10.88	3.87	12.69	4.42	14.50	6.63	21.75
	30°	3.17	10.39	3.69	12.12	4.22	13.86	6.33	20.78
	35°	3.00	9.83	3.50	11.47	4.00	13.11	5.99	19.66
	40°	2.80	9.19	3.27	10.72	3.74	12.26	5.61	18.39
45°	2.59	8.49	3.02	9.90	3.45	11.31	5.17	16.97	

*Effective blade length is the amount of blade coverage the machine is capable of when the blade is at a given angle.

EXTREME SLOPE OPERATION

There are two ways of defining slope work. The slope perpendicular to the machine's direction of travel is commonly referred to as "Side Sloping." The slope parallel to the machine's direction of travel — the machine's ability to travel up or down terrain, is commonly referred to as "Gradeability."

Side Sloping capability for our Cat graders is somewhat subjective, but general agreement among professional operators is that working on a slope ratio of 2.5:1 (21.8 degrees) is the safe limit ... an experienced operator may be able to operate on a 2:1 (28 degrees) slope. Many factors influence this limit such as operator experience, machine configuration, tires and soil conditions, but a 2.5:1 is achievable. Further, a 3:1 slope is the approximate maximum side slope a grader can work on in straight frame configuration. The steeper side slopes all require the machine be articulated to safely navigate the slope.

Gradeability is approximately 22 degrees. This is established by the grader's ability to stop without skidding the tires while moving downhill. The motor grader can, however, *climb* grades steeper than 22 degrees. The traction coefficient is the critical factor in determining whether a grader can safely navigate the slope. Caterpillar recommends that you never climb a slope steeper than you can safely descend.

Maximum lubrication angle: We have measured the graders on a tilt table and pump cavitation occurs around 30 degrees (58% or 1.7:1). This is beyond the grade or slope a motor grader can operate on.

When working side hills and slopes, consideration should be given to the following important points.

- **Speed of Travel** — At higher speeds, inertia forces tend to make the grader less stable.
- **Roughness of Terrain or Surface** — Ample allowance should be made where the terrain or surface is uneven.
- **Mounted Equipment** — Mounted attachments such as front plows, snow wings, rippers and other mounted equipment cause the tractor to balance differently.
- **Nature of Surface** — New earthen fills may give way with the weight of the grader. Rocky surfaces may promote side slipping of grader.
- **Excessive Loads or Side Draft** — This may cause wheel slippage, where the downhill tires "dig in," increasing the angle of grader.
- **Tire Selection and Maintenance** — Consideration should be given to proper tire selection and air pressure. For more information, consult Caterpillar publications — Motor Grader Tire Selection Guide and Operation and Maintenance Manual.
- **Drawbar, Circle and Blade Position** — The position of the blade can affect the stability of the machine.
- **Articulation Angle** — Articulation angle can affect the stability of the machine.
- **Wheel Lean Angle** — Wheel lean angle can affect the stability of the machine.

NOTE: Safe operation on steep slopes may require special machine maintenance as well as excellent operator skill and proper equipment setup for the specific application. Consult Caterpillar publications for further operating tips — Operation & Maintenance Manual, Motor Grader Application Guide, and the Grade Comparison Chart in the Tables section of this Performance Handbook.

Work Tool	120M/ 120M2	12M/ 12M2/ 12M3	140M/ 140M2/ 140M3	160M/ 160M2/ 160M3	16M3/ 18M3	14M	24M
	Lift Group	x	x	x	x	x	x
V-Plow	x	x	x	x	—	x	—
One Way Plow	x	x	x	x	—	x	—
Manual Reversible Plow	—	—	—	—	—	x	—
Hydraulic Reversible Plow	x	x	x	x	—	x	—
Snow Wing	x	x	x	x	—	x	—
Mid Mount Scarifier	x	x	x	—	—	—	—
Front Scarifier	x	x	x	x	—	x	—
Manual Angle Blade	x	x	x	x	—	x	—
Hydraulic Angle Blade	x	x	x	x	—	x	—
Straight Blade	x	x	x	x	x	x	—

This list is not all-inclusive.

See Price Lists, Cat Work Tools (Cat WT) Price List, and your Cat dealer for special attachment needs.

Attachments for Cat motor graders require additional hydraulics.

Most front-mounted attachments require a Quick Attach-Detach Parallel Lift Group.

ON-HIGHWAY TRUCKS (for Sale in North America Only)

CONTENTS

Preface	12-1
Features	12-2
Chassis Types	12-3
Specifications	12-12
Weight Distribution	12-13
GVWR and GCWR	12-14
Frame Selection	12-15
Selecting Gear Ratios for Transmission and Axles	12-18
Engine Selection	12-19
Driveline Braking	12-23
Appendix A Reference Equations (English Units)	12-24
Appendix B Vehicle Identification Number (VIN Structure)	12-25
Appendix C CT13 Torque Curves	12-26
Appendix D Transmission Specifications	12-32
Appendix E Rear Axle Specifications	12-36
Appendix F Front Axle Specifications	12-38
Lift Axle Specifications	12-38
Appendix G CX31 Startability Reference Guide	12-39
Appendix H Front Tire Specifications	12-40
Appendix I Rear Tire Specifications	12-42
Appendix J Front Suspension Specifications	12-46
Appendix K Rear Suspension Details	12-48
Appendix L Rear Suspension Specifications	12-51
Appendix M Power Take Off Specifications	12-52

PREFACE

This handbook is a guide that can be used as a first step when configuring a truck. It allows the user to examine options and variables that affect performance of the driveline and frame.

Trucks are highly configurable machines. There are numerous choices for every major component (frame, engine, transmission, tires, axles, suspension, gear ratios, etc.). It's critical not to over or under spec a truck for an application. A well spec'd truck is typically a balance between variables like cost, GVWR, maximum speed, gradeability, startability, and fuel economy. There are also intangibles like driver preference, serviceability, and customer history to consider.

The equations and methodology in this handbook are provided to help select components and predict how they will work together to create a truck with the desired level of performance.

Time spent investigating the customers needs is critical for creating a well configured truck that will meet or exceed customer expectations. Normally, experts with years of experience and/or classroom training perform this type of work.

FEATURES

Cat® CT13 Engines

- **Cat CT Series Engines** meet EPA regulatory requirements.
- **6 cylinder — 4 valve per cylinder with intercooled dual turbochargers** for excellent response.
- **High pressure common rail fuel system** improves fuel efficiency and reduces soot.
- **Compact graphite iron block (13L)** reduces weight/ noise and increases strength.
- **Separate cooling and oil passages for block and head** to eliminate head gasket leaks.

Transmission

- **Cat CX31 full automatic:** 6 speed (based on Cat 730 articulated transmission).
 - Full electronic control allows Jake Brake integration and advanced body builder options.
 - Two standard power takeoff ports at 1 o'clock and 8 o'clock.
 - Optional rear power takeoff port allows easier access to install and service pumps.
 - External solenoids and filter allow for quicker maintenance and troubleshooting.
 - Torque converter locks up near the end of 2nd gear. Can be programmed to lock in 1st gear.
- **Eaton Fuller manual transmission:** 10–18 speeds. 10 speed manual standard.
- **Eaton Fuller Ultrashift Plus Vocational:** 10–18 speeds.

Cab Exterior

- **Premium, conventional, aluminum alloy cab** (riveted + glued) for extra strength.
- **Sloped Metton hood** for CT660 provides excellent visibility to the ground.
- **Large curved front window (1 or 2 piece)** for maximum visibility to the sides.
- **Cowl mounted mirrors** that are heated, powered, lit, and break away to reduce impact damage.
- **Three piece bumper and grill surround** for CT660 and CT680 reduces repair costs after an impact.
- **TPO fender flairs** protect the hood.
- **Piano style door hinges** for a super tight seal and to reduce wind noise.
- **Front mounted PTO (FEMPTO)** for CT681.
- **Integral front frame extensions** for CT681.
- **Stationary grill** for CT681.

Cab Interior

- **Premium grade sound insulation package** reduces operator fatigue.
- **Primary gauges** are clearly visible through the steering wheel for easy access.
- **Powered mirrors, windows, and door locks.**
- **Ergonomic dash board with tilted center stack** for easy access and storage.
- **Large rocker switches with tactile feedback.** Can be used with gloves on.
- **Maximized door, dash, overhead, and back panel storage.**
- **Radio (hands free cell, CD, USB, 1/8 auxiliary) + factory installed CB wiring.**
- **Oversized HVAC system** for quick maximum heating, defrosting, and cooling.

Chassis Types

- CT660L
- SBA ● 122 BBC ● 4x4
- All Axles Powered

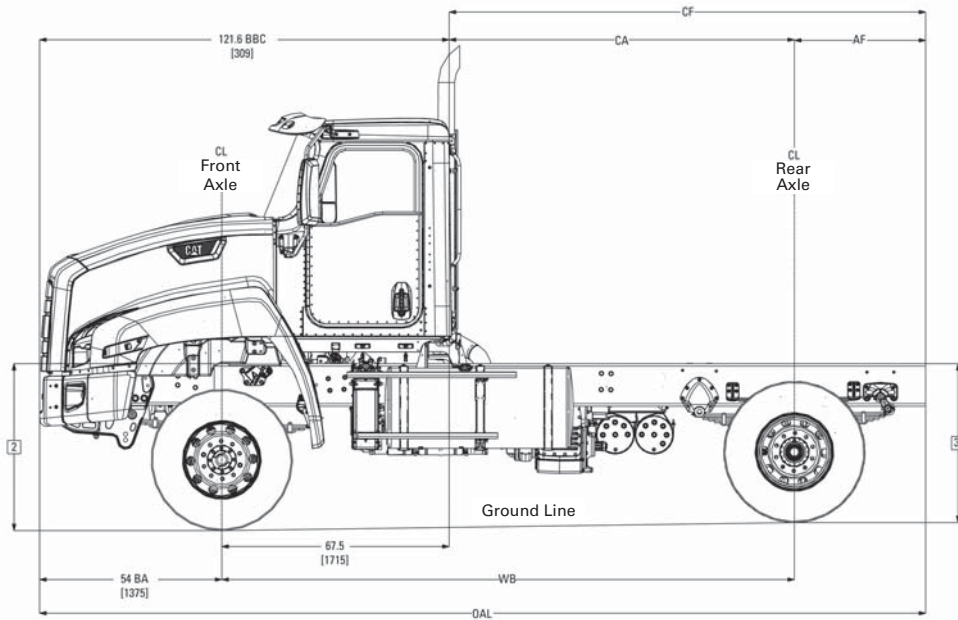

Wheelbase (in)	Chassis Weight (lb)*			Dimensions (in)				Turning Radius**
	Front	Rear	Total	CA	CF	AF	OAL	To Curb
170	11,346	5466	16,812	101.4	154.5	39	270.6	22'0"
188				119.1	172.2	39	288.3	23'10"
206				136.8	190	39	306	25'7"

*Weight includes standard chassis, oil and water, less fuel.

**Maximum turning radius with 11R22.5 tires.

On-Highway Trucks

Chassis Types

- CT660L
- SBA ● 122 BBC ● 6x6
- All Axles Powered

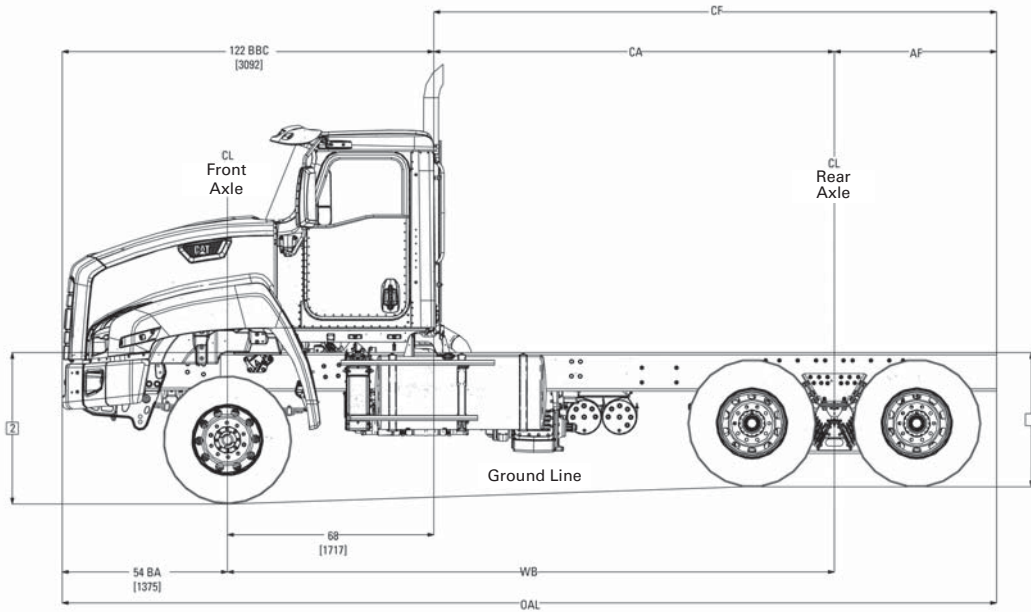

Wheelbase (in)	Chassis Weight (lb)*			Dimensions (in)				Turning Radius**
	Front	Rear	Total	CA	CF	AF	OAL	To Curb
163				95.4	148.5	53	270.6	21'4"
181				113.1	166.2	53	288.3	23'1"
199	11,348	7199	18,547	130.8	184	53	306	24'11"
211				195.8	195.8	53	317.8	26'1"

*Weight includes standard chassis, oil and water, less fuel.

**Maximum turning radius with 11R22.5 tires.

Chassis Types

- CT660S
- SBA ● 116 BBC ● 6x4
- Rear Tandem Axles Powered

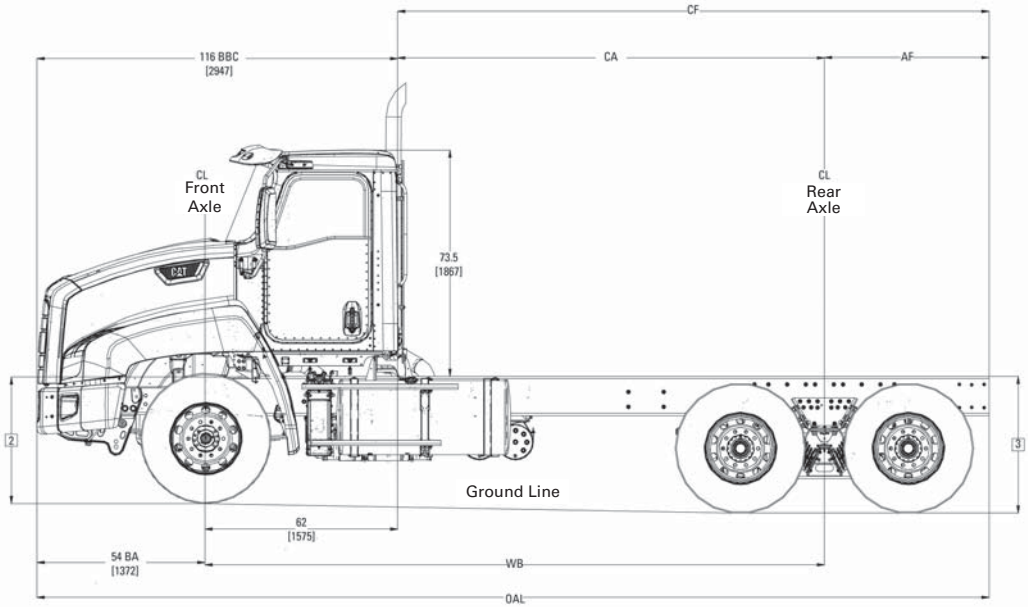

Wheelbase (in)	Chassis Weight (lb)*			Dimensions (in)				Turning Radius**
	Front	Rear	Total	CA	CF	AF	OAL	To Curb
163				101.4	154.5	53	270.6	21'4"
181				119.1	172.2	53	288.3	23'1"
199	9545	6674	16,219	136.8	190	53	306	24'11"
211				148.6	201.8	53	317.8	26'1"

*Weight includes standard chassis, oil and water, less fuel.

**Maximum turning radius with 11R22.5 tires.

On-Highway Trucks

Chassis Types

- CT660L
- SBA ● 122 BBC ● 6x4
- Rear Tandem Axles Powered

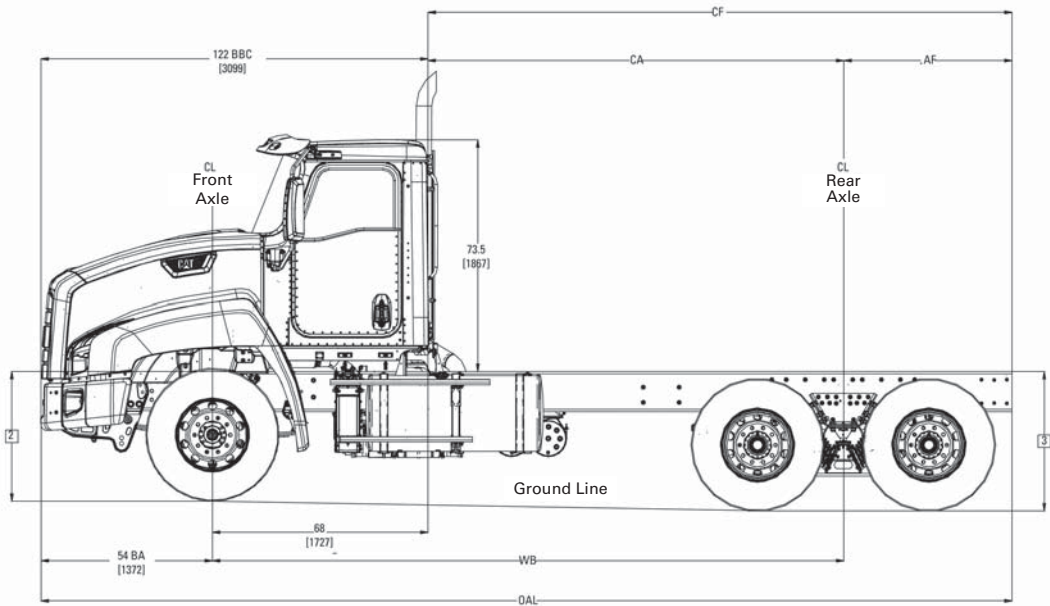

Wheelbase (in)	Chassis Weight (lb)*			Dimensions (in)				Turning Radius**
	Front	Rear	Total	CA	CF	AF	OAL	To Curb
163				95.4	148.4	53	270.4	21'4"
181				113.1	166.1	53	288.1	23'1"
199	9509	7028	16,537	130.8	183.8	53	305.8	24'11"
211				142.6	195.6	53	317.6	26'1"

*Weight includes standard chassis, oil and water, less fuel.

**Maximum turning radius with 11R22.5 tires.

Chassis Types

- CT660S
- SBA ● 116 BBC ● 8x6
- Rear Tridem Axle Powered

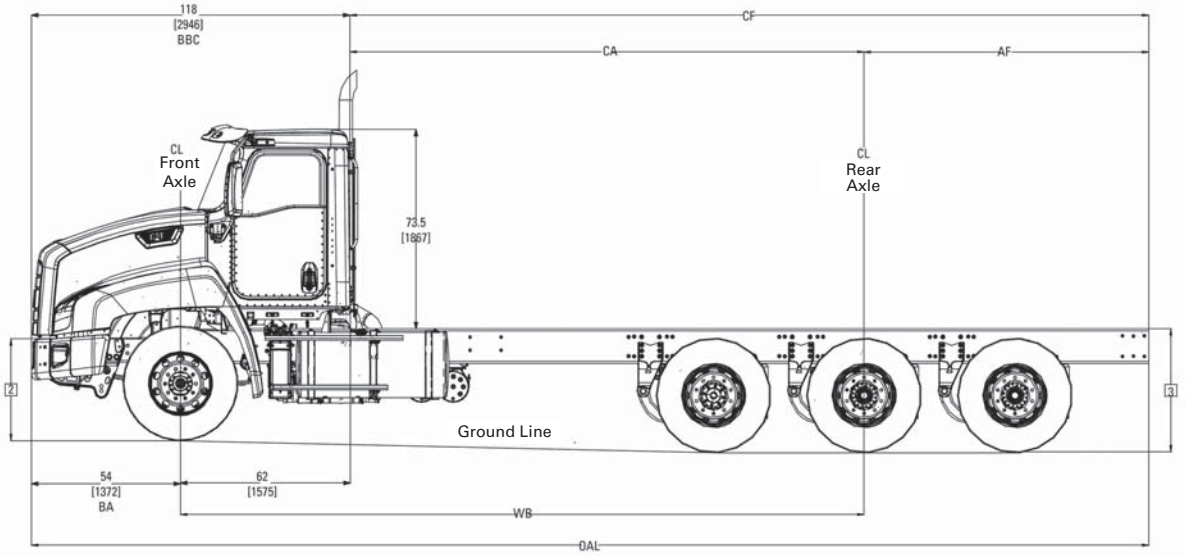

Wheelbase (in)	Chassis Weight (lb)*			Dimensions (in)				Turning Radius**
	Front	Rear	Total	CA	CF	AF	OAL	To Curb
250	10,176	9379	19,573	188	292	104	408	29'11"
252				190	294	104	410	30'1"
286				224	328	104	444	33'6"
321				258.9	363	104	479	37'1"

*Weight includes standard chassis, oil and water, less fuel.

**Maximum turning radius with 11R22.5 tires.

On-Highway Trucks

Chassis Types

- CT660L
- SBA ● 122 BBC ● 8x6
- Rear Tridem Axle Powered

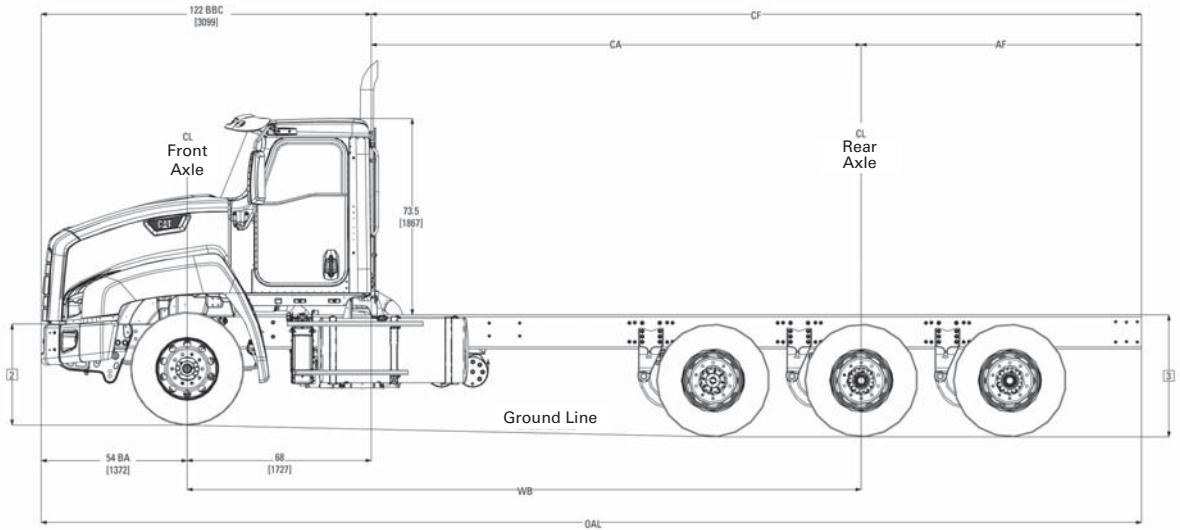

Wheelbase (in)	Chassis Weight (lb)*			Dimensions (in)				Turning Radius**
	Front	Rear	Total	CA	CF	AF	OAL	To Curb
250	9835	9774	19,609	182	286	104	408	29'11"
252				184	288	104	410	30'1"
286				218	322	104	444	33'6"
321				356.9	356.9	104	478.9	37'1"

*Weight includes standard chassis, oil and water, less fuel.

**Maximum turning radius with 11R22.5 tires.

Chassis Types

- CT681
- SFA ● 114 BBC ● 6x4
- Rear Tandem Axles Powered

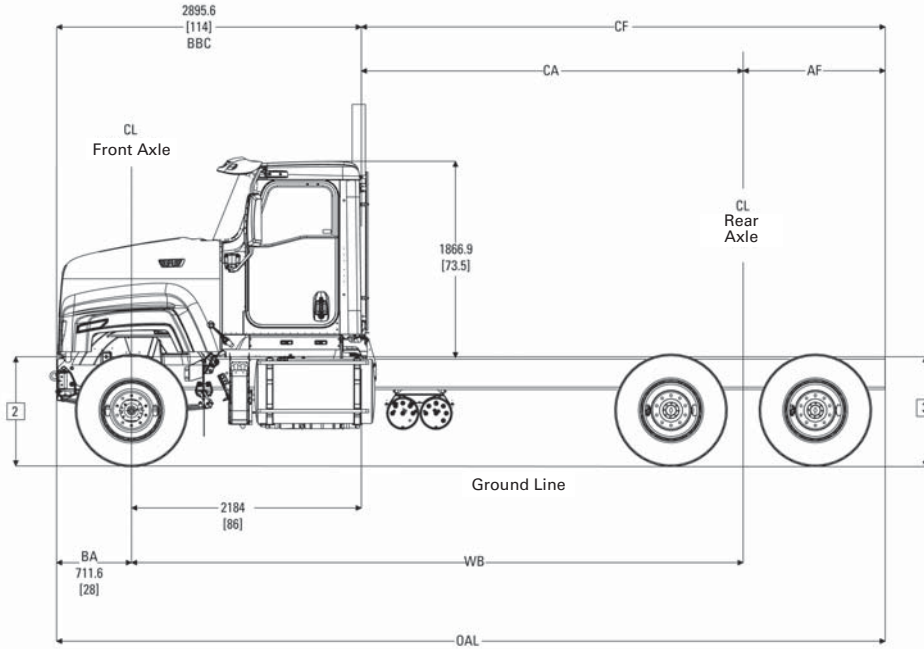

Wheelbase (in)	Chassis Weight (lb)*			Dimensions (in)				Turning Radius**
	Front	Rear	Total	CA	CF	AF	OAL	To Curb
188				102	156	54	270	30'0"
206				120	174	54	288	32'4"
224	7955	7082	15,037	138	192	54	306	34'7"
236				150	204	54	318	36'2"

*Weight includes standard chassis, oil and water, less fuel.

**Maximum turning radius with 11R22.5 tires.

On-Highway Trucks

Chassis Types

- CT680
- SFA ● 124 BBC ● 6x4
- Rear Tandem Axles Powered

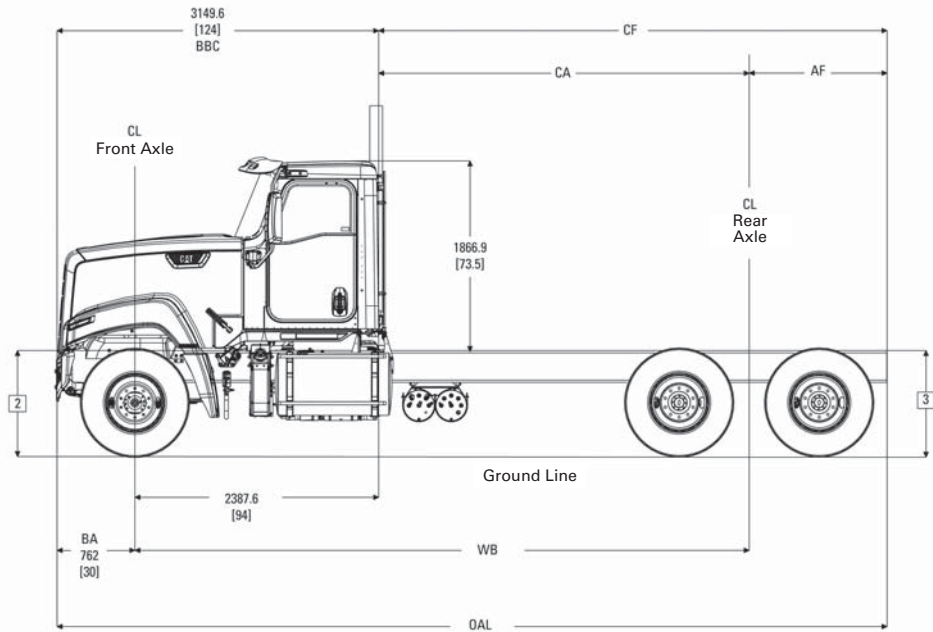

Wheelbase (in)	Chassis Weight (lb)*			Dimensions (in)				Turning Radius**
	Front	Rear	Total	CA	CF	AF	OAL	To Curb
192				102	156	54	276	30'6"
210				120	174	54	294	32'9"
228	8880	7609	16,489	138	192	54	312	35'1"
240				150	204	54	324	36'8"

*Weight includes standard chassis, oil and water, less fuel.

**Maximum turning radius with 11R22.5 tires.

Chassis Types

- CT680
- SFA ● 124 BBC ● 8x6
- Rear Tridem Axle Powered

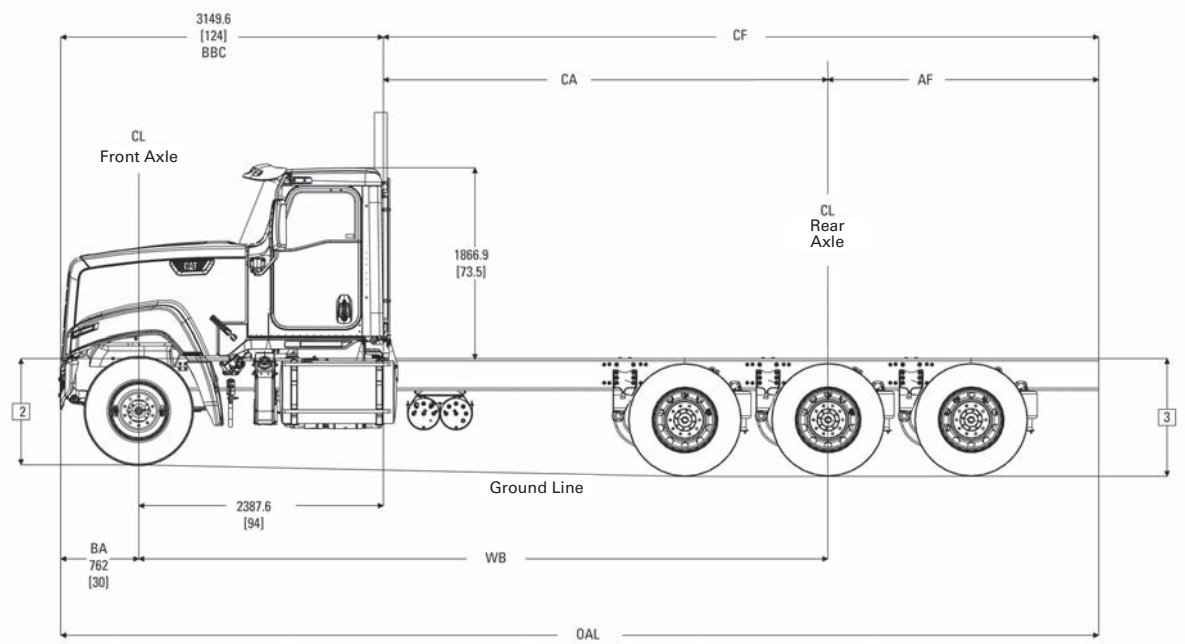

Wheelbase (in)	Chassis Weight (lb)*			Dimensions (in)				Turning Radius**
	Front	Rear	Total	CA	CF	AF	OAL	To Curb
192				102	156	54	276	30'6"
210				120	174	54	294	32'9"
228	8880	9209	18,089	138	192	54	312	35'1"
240				150	204	54	324	36'8"

*Weight includes standard chassis, oil and water, less fuel.

**Maximum turning radius with 11R22.5 tires.

General Specifications

Model	BBC	Chassis	Engine
CT660S SBA	116"	6x4, 8x6	13L
CT660L SBA	122"	4x4, 6x6	13L
CT680 SFA	124"	6x4, 8x6	13L
CT681 SFA	114"	6x4	13L

Engine Specifications

Engine	BHP/GT (lbf-ft)
CT13	365/1250; 370/1350; 390/1450; 410/1450; 430/1550; 475/1700

NOTE: CT681 available with Front Engine PTO.
Gov. Speed RPM = 2100
Available CT681 hp ranges: 365-430 hp

Wheelbase

Variable: 138" – 394"

Transmission

Cat CX31 Power Shift Automatic, (6 Fwd, 1 Rev) Speeds
(2 PTO's Std.) Opt. Rear PTO
Eaton Manual 10, 11, 13, 18 Speeds
Eaton UltraShift PLUS Vocational 10, 13, 15, 18 Speeds

Frame (120,000 psi steel)

12.25 x 3.375 x 0.375	SM = 21	RBM = 2,520,000 lb
12.65 x 3.5 x 0.5	SM = 29	RBM = 3,458,580 lb
13.03 x 3.687 x 0.6880	SM = 40	RBM = 4,865,748 lb

NOTE: CT681 available with Integral Front Frame Extension.

Axles (Meritor/Dana Spicer)

13,200 lb – 23,000 lb Front
40,000 lb – 70,000 lb Rear

Suspension (Hendrickson, Chalmers, Neway)

Front: Multi Leaf (Shackle or Slipper type)
Front: Parabolic Taper Leaf
Rear: Walking Beam, Air, Spring

Brakes (Bendix and Meritor)

ABS and ASA Standard
Front Disc Brakes for Tractor 16K Axle and above
Opt.: Traction and Stability Control

Fuel Tanks

60, 80, 100, 120 U.S. gal
Polished/non polished aluminum
Dual tanks optional

GVWR

Variable: Based on Frame, Wheelbase, Axles, Suspension,
Brakes, Wheels, and Tires selected. Also, Federal
and State Laws.

Lift Axles (Watson and Chalin)

6x4: CT660 and CT681
Pusher Type: 8000 lb-20,000 lb
Tag Type: 13,200 and 20,000 lb

WEIGHT DISTRIBUTION

The first step in spec'ing a Truck is to understand how the load is distributed on the Front and Rear Axles. The load is defined as the Maximum expected weight of a fully loaded Truck. That includes the Driver, Fuel, Fluids, Payload, and Truck Body. Once the axle loading is known, it's possible to begin selecting the Frame, Engine, Transmission, Axles, Suspension, Tires, etc.

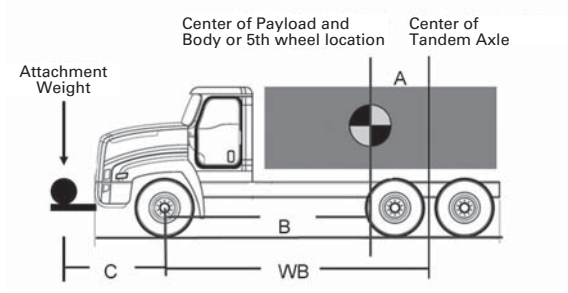

Start by identifying where (in relation to the axles) the load will come onto the truck. This can be a 5th wheel location, or the center of gravity of the Body and Payload (like a Dump Truck or Tanker). See above illustration.

Axle Loading can be found by adding up how major loads are distributed on each axle. Typical loads are the weight of the Truck Chassis, Body, Payload, or 5th wheel. Add up all the loads that apply for your Truck.

Axle Loading Due to Truck Chassis
(see "Chassis Types" tables in this section)

Front Axle Load (Given by Caterpillar) = _____ lb
 Rear Axle Load (Given by Caterpillar) = _____ lb

Axle Loading Due to Body and Payload
(omit if using a 5th wheel)

Front Axle Load = (Body + Payload weight) × (A/WB)
 = _____ lb
 Rear Axle Load = (Body + Payload weight) × (B/WB)
 = _____ lb

Axle Loading Due to 5th Wheel
(omit if using a Body)

Front Axle Load = 5th Wheel Load × (A/WB)
 = _____ lb
 Rear Axle Load = 5th Wheel Load × (B/WB)
 = _____ lb

Axle Loading Due to Forward Mounted Loads
(Winches, Plows, etc.)

Front Axle Load = Attachment weight × (C + WB)/WB = _____ lb
 Rear Axle Load = - Attachment weight × (C/WB) = - _____ lb Negative

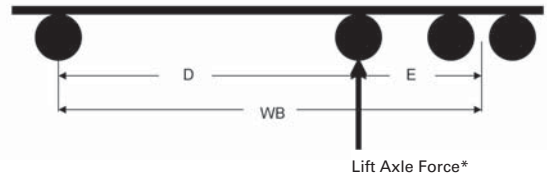

*Max Lift Force = Lift Axle (Rated Capacity) – Weight of the Lift Axle.

Example:

Max lift force for a 13,200 lb lift axle is approximately 12,000 lb. The remaining 1200 lb is the weight of the axle, tires, wheels, and brakes.

Axle Loading Due to Lift Axles*
(see above illustration)

Front Axle Load = - Lift Axle Force × (E/WB) = - _____ lb Negative
 Rear Axle Load = - Lift Axle Force × (D/WB) = - _____ lb Negative

*If more than one (1) lift axle repeat as required.

Total Axle Loading

Front Axle Load = Add all Front loads that apply = _____ lb
 Rear Axle Load = Add all Rear loads that apply = _____ lb

GVWR AND GCWR

GVWR = Gross Vehicle Weight Rating. This rating is used for a Straight Truck.

GCWR = Gross Combination Weight Rating. This rating is used for Tractors with 5th wheels.

Procedure to Determine GVWR or GCWR

- 1) Determine the maximum expected load on each axle (see Weight Distribution section).
- 2) Select Axles, Suspensions, Brakes, Wheels and Tires that are sized to take the load predicted by the Weight Distribution Study. All components must be rated equal to or greater than the expected axle loading. See Appendix D, E, F, H, I, J, K, and L for component ratings.
- 3) The lowest rated component for each axle (including the axle), is the Maximum **Axle Rating** for that axle.

GVWR = Front + Rear + Lift (Axle Rating for each axle)

GCWR = Front + Rear + Lift + Trailer (Axle Rating for each axle)

Example: Front Axle Rating

Expected Front Axle Load	12,420 lb
Axle rated for	13,200 lb
Suspension rated for	14,000 lb
Wheels rated for	14,000 lb
Tires rated for	13,800 lb
Brakes rated for	14,000 lb

In this example the front axle is the lowest rated component that will carry the load predicted by the Weight Distribution Study. Thus, the Front **Axle Rating** is 13,200 lb in this example.

Bridge Laws

Careful attention must be given to laws governing overall weight, maximum axle loading, and axle spacing. These laws are commonly referred to as Bridge Laws, and are different in every State, Region, or Province. This handbook does not cover these laws. The reader is advised to refer to their local Bridge Law formulas.

FRAME SELECTION GUIDE FOR CT660

Based on Front Axle Load, Desired GVWR and Wheelbase: Select a Frame from table below. Frame length varies in roughly two inch increments to accommodate many different body sizes. Frames can also be Reinforced (or Doubled) to carry heavier loads.

	Dimensions	Code	Front Axles	GVWR	Maximum Wheelbase															
					200	210	220	230	240	250	260	270	280	290	300	310	320	330	340	350
Not Reinforced	12.25 x 3.375 x 0.375	01CDH	12K	<=52K	331" (8400 mm)															
			13.2K	<=53.2K	329" (8350 mm)															
			14-14.6K	<=60.6K	280" (7100 mm)															
			16K	<=62K	260" (6600 mm)															
			18K	<=64K	246" (6250 mm)															
			20K	<=85K				234" (5950 mm)												
			21-22K	<=87K			222" (5650 mm)													
			23K	<=88K			215" (5450 mm)													
Reinforced	12.0 x 3.25 x 0.25 with 0.25 Outer Reinforcement	01DAV	12K	<=52K												360" (9150 mm)				
			13.2K	<=53.2K												360" (9150 mm)				
			14-14.6K	<=60.6K												358" (9100 mm)				
		01GDL	16K	<=62K	325" (8250 mm)															
			18K	<=64K	299" (7600 mm)															
			20K	<=98K	293" (7450 mm)															
			21-22K	<=100K	276" (7000 mm)															
	23K	<=101K	266" (6750 mm)																	
Reinforced	12.25 x 3.375 x 0.375	01CDH	12K	<=52K												360" (9150 mm)				
			13.2K	<=53.2K												360" (9150 mm)				
			14-14.6K	<=60.6K												360" (9150 mm)				
	01GDM	16K	<=62K												360" (9150 mm)					
		18K	<=64K	352" (8950 mm)																
		20K	<=98K	317" (8050 mm)																
		21-22K	<=100K	309" (7850 mm)																
	23K	<=101K	301" (7650 mm)																	

**FRAME SELECTION GUIDE
FOR CT680 AND CT681**

Based on Front Axle Load, Desired GVWR and Wheelbase: Select a Frame from table below. Frame length varies in roughly two inch increments to accommodate many different body sizes. Frames can also be Reinforced (or Doubled) to carry heavier loads.

Dimensions	Code	Front Axles	GVWR	Maximum Wheelbase																
				200	210	220	230	240	250	260	270	280	290	300	310	320	330	340	350	360
12.25 x 3.375 x 0.375	01CDH	12K	<=52K	299" (7600 mm)																
		13.2K	<=53.2K	274" (6950 mm)																
		14K	<=60K	258" (6550 mm)																
		16K	<=62K	258" (6550 mm)																
		18K	<=64K	254" (6450 mm)																
		20K	<=66K	254" (6450 mm)																
		20K	<=85K			205" (5200 mm)														
12.0 x 3.25 x 0.25 with 0.25 Outer Reinforcement	01DAV 01GDL	12K	<=52K	360" (9150 mm)																
		13.2K	<=53.2K	337" (8550 mm)																
		14K	<=60K	329" (8350 mm)																
		16K	<=62K	299" (7600 mm)																
		18K	<=64K	283" (7200 mm)																
		20K	<=66K	283" (7200 mm)																
		20K	<=85K	270" (6850 mm)																
12.25 x 3.375 x 0.375 with 0.312 Outer Reinforcement	01CDH 01GDM	12K	<=52K	360" (9150 mm)																
		13.2K	<=53.2K	360" (9150 mm)																
		14K	<=60K	360" (9150 mm)																
		16K	<=62K	348" (8850 mm)																
		18K	<=64K	339" (8600 mm)																
		20K	<=66K	319" (8100 mm)																
		20K	<=85K	295" (7500 mm)																

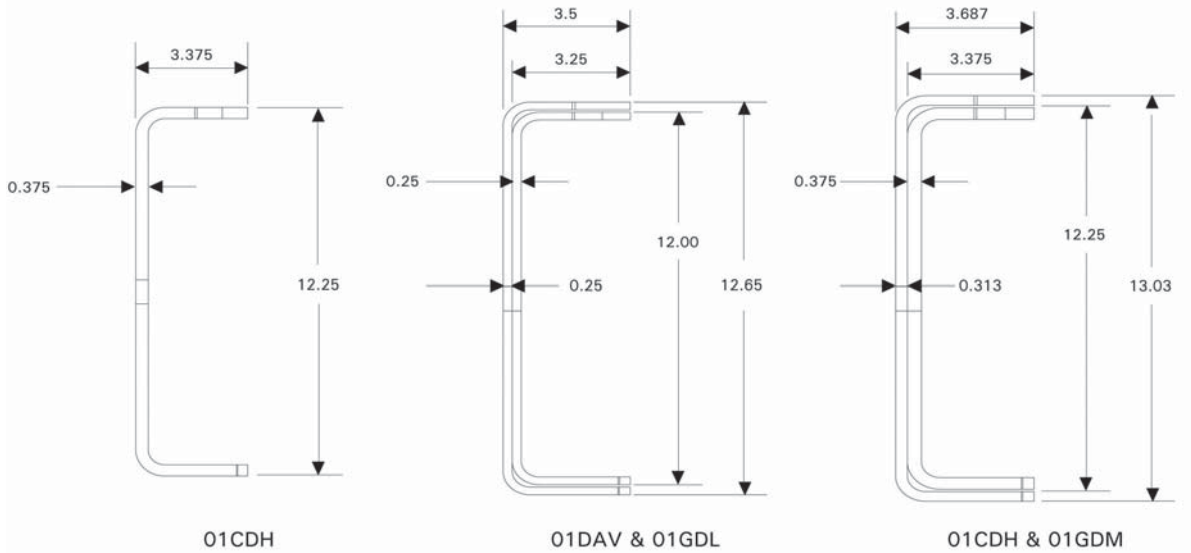

Standard Frame Not Reinforced

SM = 21 in³

RBM = 2,520,000 lb

Optional Reinforced Frame

SM = 28.82 in³

RBM = 3,458,580 lb

Optional Reinforced Frame

SM = 40.45 in³

RBM = 4,865,748 lb

SM = Section Modulus is based on the cross sectional area of the frame and its distance from the neutral axis of bending.

RBM = Resistance to Bending Moment = SM × Steel Strength = SM × 120,000 psi for All Cat Frames.

SELECTING GEAR RATIOS FOR TRANSMISSION AND AXLES

Select the Desired Axle Ratio (AR)

$$AR = \frac{RPM \text{ (at cruise)} \times 60}{TR \times MPH \times M \times ATR \times DBR}$$

NOTE: This equation provides the Theoretical axle ratio. Select the closest axle ratio found in Appendix E.

RPM = Engine RPM at desired cruise. See table below or Torque Curves in Appendix C.

TR = Transmission ratio (Top gear). See Appendix D.

MPH = Desired cruise speed (not maximum speed).

M = Tire revolutions per mile. See Appendix I.

ATR = Auxiliary Transmission ratio. See Appendix D.

DBR = Drop Box Ratio. See Appendix D (omit if 1:1).

60 = Constant.

Suggested Cruise Speeds

Engine Family	Application	Engine Speed for Fuel Economy	Engine Speed for Performance	Vehicle Cruise Speed
CT13	Vocational	1375-1500	1500-1650	55
CT13	Extended Highway	1325-1375	1375-1450	65

Select the Desired Transmission Ratio (TR) Top Gear/Overdrive

$$TR = \frac{RPM \text{ (at cruise)} \times 60}{AR \times MPH \times M \times ATR \times DBR}$$

NOTE: For AR, use the Axle ratio selected from Appendix E.

NOTE: This equation provides the Theoretical Transmission ratio. Select the closest actual gear ratio from Appendix D.

Verify Cruise and Maximum Speed

Use the actual Transmission and Axle ratios you selected from Appendix D and E to verify the desired cruise and Maximum speed. Do not use the theoretical values. If you're within 5 mph of your desired cruise speed that is a good gearing combination. Otherwise, modify your choices for the Axle or Transmission Ratios to get closer. It may take a few attempts to meet your requirements.

$$MPH \text{ (cruise)} = \frac{RPM \text{ (at cruise)} \times 60}{AR \times TR \times M \times ATR \times DBR}$$

$$MPH \text{ (Max)} = \frac{2100 \text{ (max RPM)} \times 60}{AR \times TR \times M \times ATR \times DBR}$$

NOTE: Use the actual AR and TR selected from Appendix D and E for MPH (cruise) and MPH (Max).

ENGINE SELECTION

There are many factors that dictate the correct engine size for a specific application. It’s possible to use a mathematical approach to add up all the horsepower demands to size the engine. However, it’s also important to understand the application and driver habits. In addition, understand how the customer’s other trucks are configured. This critical customer knowledge is used to verify or modify the results of the mathematical approach to achieve the best engine selection for the application.

Mathematical Approach Overview: 3 step process.

- 1) Add up all the HP loads at vehicle cruise speed. Examples of HP demands are: Rolling Resistance, Drag, Slopes, Road Surface, Driveline Losses, Accessories, and Power Takeoffs.
- 2) Determine the Torque required to start fully loaded on the customer’s maximum grade. This is called (Startability).
- 3) Use your knowledge of the application to verify if the Engine selected in steps 1 and 2 makes sense.

Step 1 Calculations: Add up the HP required at the expected vehicle cruise speed.

NOTE: All the following formulas can be programmed into a Spread Sheet for faster evaluation.

Rolling Resistance: The HP required on a flat surface to overcome Tire Squat. Since tires are not perfectly round, (especially when loaded) the Truck is climbing a small slope just to move forward.

$$Pr = \frac{(6.1 + (0.06 \times MPH)) \times Cp \times GW \times MPH}{375,000}$$

Cp = Tire Pavement Factors. See table below.

GW = Gross Vehicle Weight or Gross Combination Weight required for the application.

6.1 = Constant.

0.06 = Constant.

375,000 = Constant.

MPH = Desired Cruise Speed (not maximum speed).

Tire Pavement Factors

Surface	Bias	Radial	LP Radial	Wide Base
Concrete	1.00	0.70	0.63	0.50
Cold Blacktop	1.20	0.85	0.70	0.60
Hot Blacktop	1.50	0.90	0.83	0.70
Hard Soil	1.75	1.00	0.98	0.85
Hard Gravel	2.00	1.20	1.13	1.00
Loose Gravel	7.50	1.70	1.63	1.50
Sand	12.00			

Air Resistance: The HP required to overcome wind resistance. This starts becoming significant above 30 MPH. Over 65 MPH it can be the largest single load.

$$Pa = \frac{FA \times Cd \times MPH^3}{156,000}$$

Cd = Aerodynamic Drag Coefficient. See table below.

FA = Frontal Area of the Truck (sq ft) + Area of the body or trailer that is wider or taller than the Truck. If the trailer is more than eight feet behind the Truck, FA = the Frontal Area of the Truck + the Total Frontal area of the Trailer. See illustration below.

156,000 = Constant.

MPH = Desired Cruise Speed (not maximum speed).

Aerodynamic Drag Coefficients

Configuration	Factor
HD Tractor – Full Aero/Van Trailer Full Aero	0.42
HD Tractor – Full Aero/Van Trailer Typical	0.48
MD Van Truck – Full Aero	0.50
HD Tractor – Full Aero/Van Trailer some Aero	0.54
HD Tractor – Full Aero/Tank Trailer Insulated	0.55
HD Tractor – Full Aero/Flat Trailer some Aero (Smooth Load)	0.55
HD Tractor – Full Aero/Van Trailer no Aero	0.80
HD Tractor – Full Aero/Flat Trailer some Aero (Rough Load)	0.80
HD Tractor – Full Aero/Tank Trailer Non Insulated	0.80
HD Tractor – No Aero/Van Trailer no Aero	0.80
MD Van Truck – No Aero	0.80
HD Dump	0.90
MD Dump – No Aero	0.90
HD Tractor – Car Hauler	1.00
HD Tractor – No Aero/Flat Trailer some Aero	1.00

Aero refers to side panels and deflectors to make the Truck more aerodynamic.

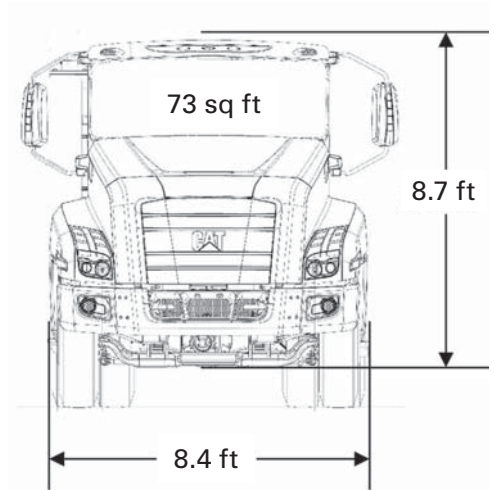

Gradeability: The reserve HP required to operate indefinitely (without downshifting) at the desired cruise speed on a small grade between 0.5% – 1% Grade.

$$Pg = \frac{G \times GW \times MPH}{37,500}$$

G = Grade Percent (Typically 0.5 or 1).

GW = Desired Gross Vehicle Weight or Gross Combination Weight.

37,500 = Constant.

MPH = Desired Cruise Speed (not maximum speed).

Accessories: The HP required to power the Cooling Fan, Alternator, Power Steering, A/C and Air Compressor at the desired cruise speed.

$$P_{acc} = 57 \text{ HP @ 1600 RPM} = 73 \text{ HP at 1800 RPM}$$

Considering 2100 is Max Engine RPM. Select a Pacc that best matches your application.

PTO: The HP required to power Mixers, Pumps, Generators, etc. that are running while the truck is cruising.

$$P_{pto} = \text{Supplied by Body Builder}$$

Zero if not running while cruising

Total HP Required at the Drive Wheel

$$P_{req} = P_r + P_a + P_g + P_{acc} + P_{pto}$$

Engine Selection: Account for Driveline losses and select an Engine with at least as much HP as P(eng) from table below. Continue to Step 2, to verify the Engine you selected has the required Torque.

$$P_{eng} = \frac{P_{req}}{0.93}$$

0.93 = Driveline Efficiency

Engine Specifications

Engine	Horsepower (BHP @ 1700 RPM)	Torque Peak (lbf-ft @ 1000 RPM)	Gov. Speed (RPM)	Fully Developed Torque (lbf-ft at 800 RPM)
CT13	365	1250	2100	686
CT13	370	1350	2100	770
CT13	390	1450	2100	811
CT13	410	1450	2100	828
CT13	430	1550	2100	868
CT13	475	1700	2100	959

Step 2A: (Manual and Automated Manual Transmissions) Verify the Engine selected in Step 1 can get the Truck moving on the customer’s maximum grade.

Startability: Is the ability of the truck to start moving on the steepest grade the driver will face. The equation below (S) calculates the **Theoretical** Maximum Percent grade for the Engine you selected in Step 1. To more accurately predict Startability, ground conditions must be considered. Subtract the effects of ground conditions from (S) to determine the Maximum Predicted Startability.

$$S = \frac{(Tc \times R \times M)}{(10.7 \times GW)}$$

Tc = Fully Developed Torque (from Engine selected in Step 1). See Engine Specification table.

R = The overall Driveline gear ratio.

$\frac{\text{Transmission (low gear)} \times \text{Axle} \times \text{Aux Trans} \times \text{Drop box}}{\text{Omit Aux Trans and Drop Box ratios if not used}}$

M = Tire Revolutions per mile. See Appendix I.

GW = Desired Gross Vehicle Weight or Gross Combination Weight.

10.7 = Constant.

Ground Conditions: See Tire Pavement Factors table or Subtract 6% for every inch of tire penetration.

Maximum Predicted Startability

= S – Ground Conditions

Startability must be equal to or greater than the customer’s maximum percent grade. If below Maximum, Select an Engine of equal or greater HP with Higher Fully Developed Torque from Engine Specifications table. Rerun the Startability calculations to verify. Continue to Step 3 for final Engine selection.

Step 2B: (CX31 Automatic Transmission) Verify the Engine selected in Step 1 can get the Truck moving on the customer’s maximum grade.

Startability: Is the ability of the truck to Start moving on the steepest grade the driver will face. For an Automatic Transmission a simple equation cannot be used to predict Startability. For the CX31, see the Startability chart in Appendix G. It assumes starting on the best concrete. To more accurately predict Startability, ground conditions must be considered. Subtract the effects of ground conditions from (S) to determine the Maximum Predicted Startability.

S = See Appendix G

Ground Conditions: See Tire Pavement Factors table or Subtract 6% for every inch of tire penetration.

Maximum Predicted Startability

= S – Ground Conditions

Startability must be equal to or greater than the customer’s maximum percent grade. If below Maximum, Select an Engine with equal or greater HP and Higher Fully Developed Torque from Engine Specifications table. Rerun the Startability calculations to verify.

Step 3: Final Engine Selection. In Steps 1 and 2 you selected an Engine that had enough HP to maintain cruise speed and start on the maximum grade. Before making the final Engine selection, factor in application and driver habits. For example, additional Torque may be required in mountainous regions. Perhaps a smaller Engine can be used to save fuel if the driveline gearing is modified.

DRIVELINE BRAKING

Driveline Braking is used to augment the main service brake system. A technology called Engine Compression Braking allows the engine to remove horsepower from the driveline by compressing air. In addition to providing additional stopping power, driveline braking also reduces maintenance costs by prolonging the life of brake linings. This technology is often referred to in the industry as a “Jake Brake.”

NOTE: Engine Compression Braking is recommended for all CT660 driveline braking applications.

Engine Compression Brake HP vs. Engine RPM

Engine RPM	CT13		
	Level 1	Level 2	Level 3
1100	37	73	110
1300	57	113	170
1600	80	160	240
1700	110	220	330
1900	138	277	415
2100	157	313	470

Driver Selectable Engine Compression Brake Levels

NOTE: The driver can select levels 1-3 at anytime with a 3 way toggle switch, even during braking.

An alternate Driveline Braking option is a Transmission Retarder. This is an option within the Cat CX31 automatic Transmission. It cannot be used in conjunction with Engine Compression Braking because of driveline overload.

Engine RPM	Braking HP
900	100
1000	133
1100	164
1200	210
1300	265
1400	298
1500	335
1600	414
1700	550
1800	583
1900	615
2000	647
2100	680

Reference Equations (English Units)

$$\text{MPH} = \frac{60 \times \text{RPM}}{\text{M} \times \text{Ra} \times \text{Rt}} \qquad \text{*Miles per Hour}$$

$$\text{M} = \frac{60 \times \text{RPM}}{\text{Ra} \times \text{Rt} \times \text{MPH}} \qquad \text{*Tire Revolutions per Mile}$$

$$\text{Ra} = \frac{60 \times \text{RPM}}{\text{M} \times \text{Rt} \times \text{MPH}} \qquad \text{*Rear Axle Ratio}$$

$$\text{Rt} = \frac{60 \times \text{RPM}}{\text{M} \times \text{Ra} \times \text{MPH}} \qquad \text{*Transmission Gear Ratio (Top Gear)}$$

$$\text{RPM} = \frac{\text{MPH} \times \text{M} \times \text{Ra} \times \text{Rt}}{60} \qquad \text{*Revolutions per Minute (Engine)}$$

$$\text{Torque} = \frac{\text{HP} \times 5252}{\text{RPM}} \qquad \text{Torque in lbf-ft}$$

$$\text{Horsepower} = \frac{\text{Torque} \times \text{RPM}}{5252} \qquad \text{Horsepower in lbf-ft per Second}$$

*No Drop Box or Auxiliary Transmission.

● Vehicle Identification Number (VIN Structure)

Vehicle Identification Number (VIN Structure)

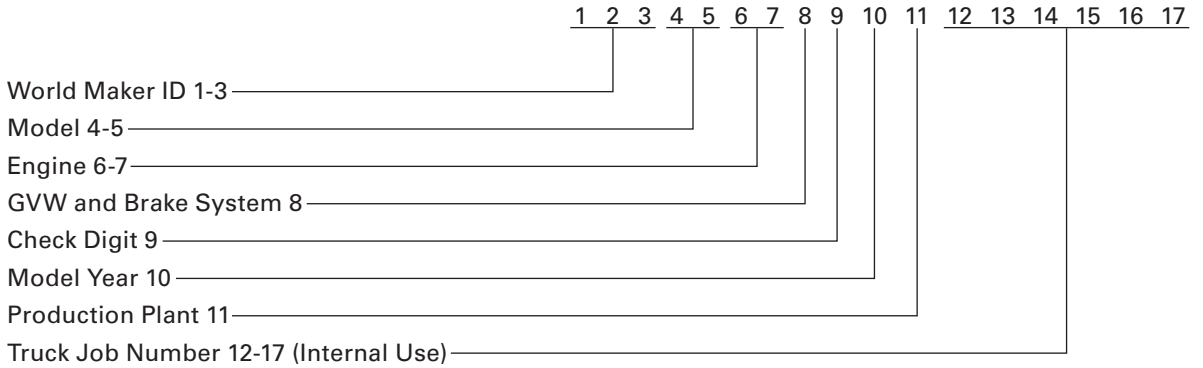

World Maker ID 1-3

- 3HP = Complete Truck
- 3HS = Complete Tractor
- 3HT = Incomplete Truck (Needs Body)

Model 4-5

- JG = CT660 6x4 112 BBC
- JK = CT660 6x4 122 BBC
- JN = CT660 4x4 122 BBC
- JP = CT660 6x6 122 BBC
- JH = CT660 8x6 112 BBC
- JL = CT660 8x6 122 BBC
- KB = CT680 6X4 124 BBC
- KA = CT681 6x4 114 BBC

Engine Size 6-7

CT13: TK

Position 8

GVW Range
 33,001 to 55,000 = R
 55,001 and Over = T

Model Year 10

- B = 2011 F = 2015
- C = 2012 G = 2016
- D = 2013 H = 2017
- E = 2014 I = 2018

Production Facility 11

N = Escobedo Mexico

Example

3HTKATKT8EN021730

An Incomplete Truck needing a body, CT681 model, CT13 Engine, GVWR over 55,000 lb, 2014 Model Year, Made in Mexico

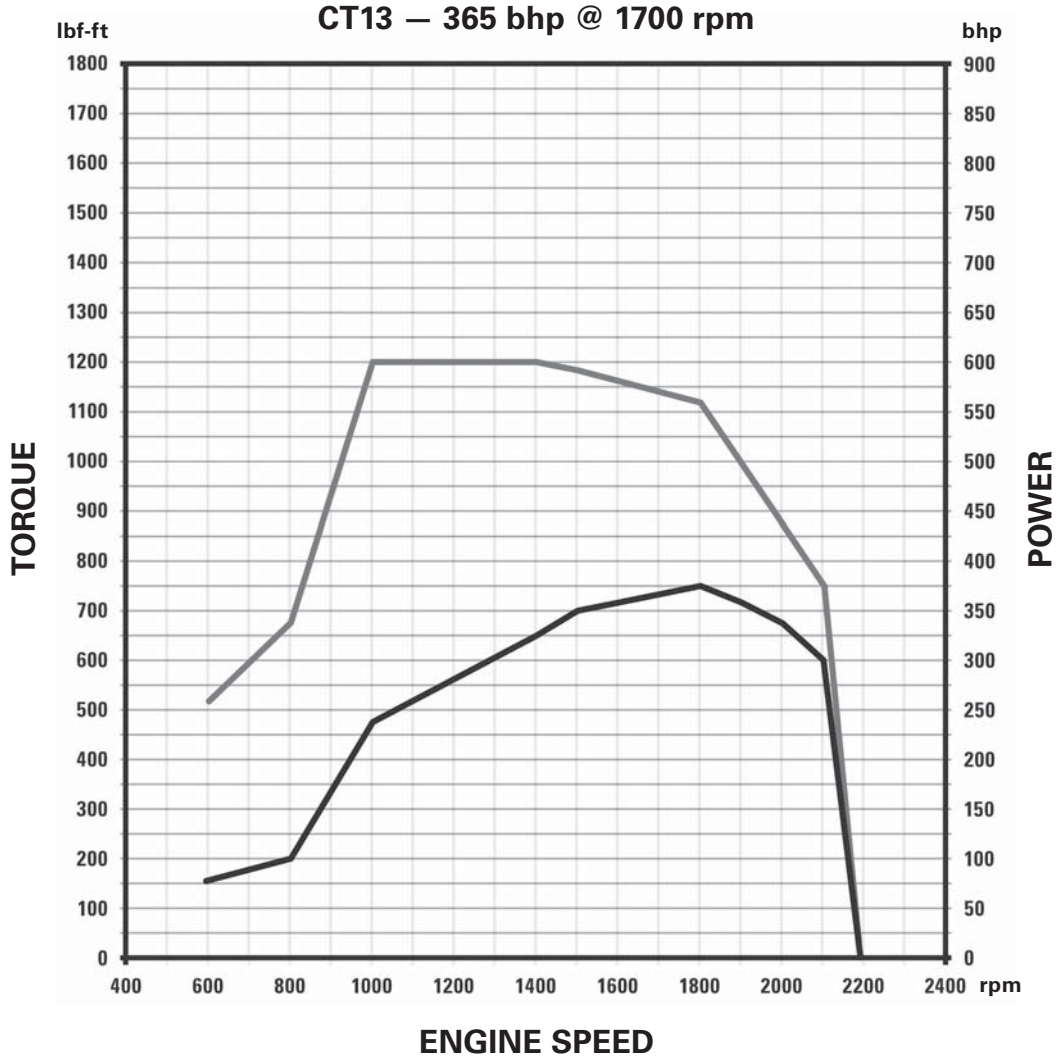

KEY
— Torque
— Power

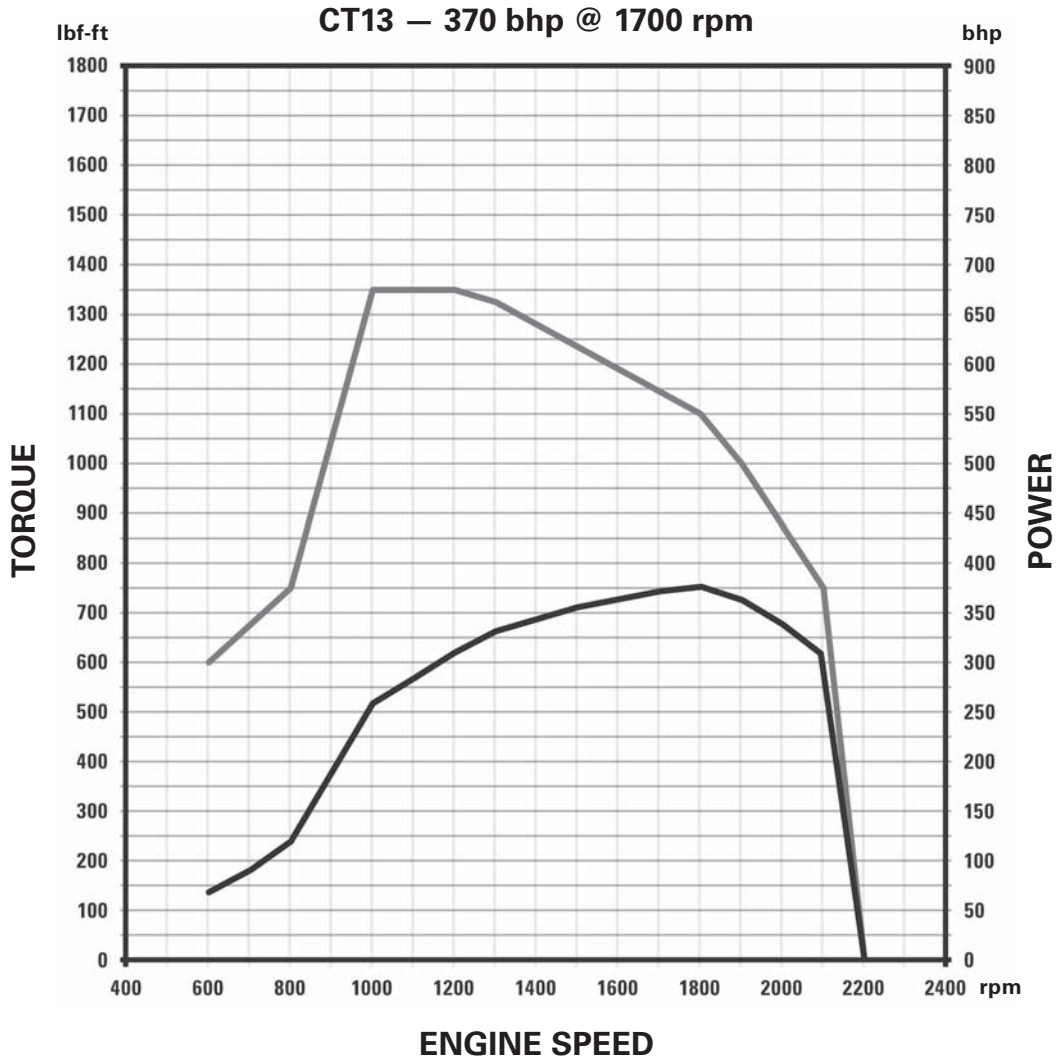

KEY
— Torque
— Power

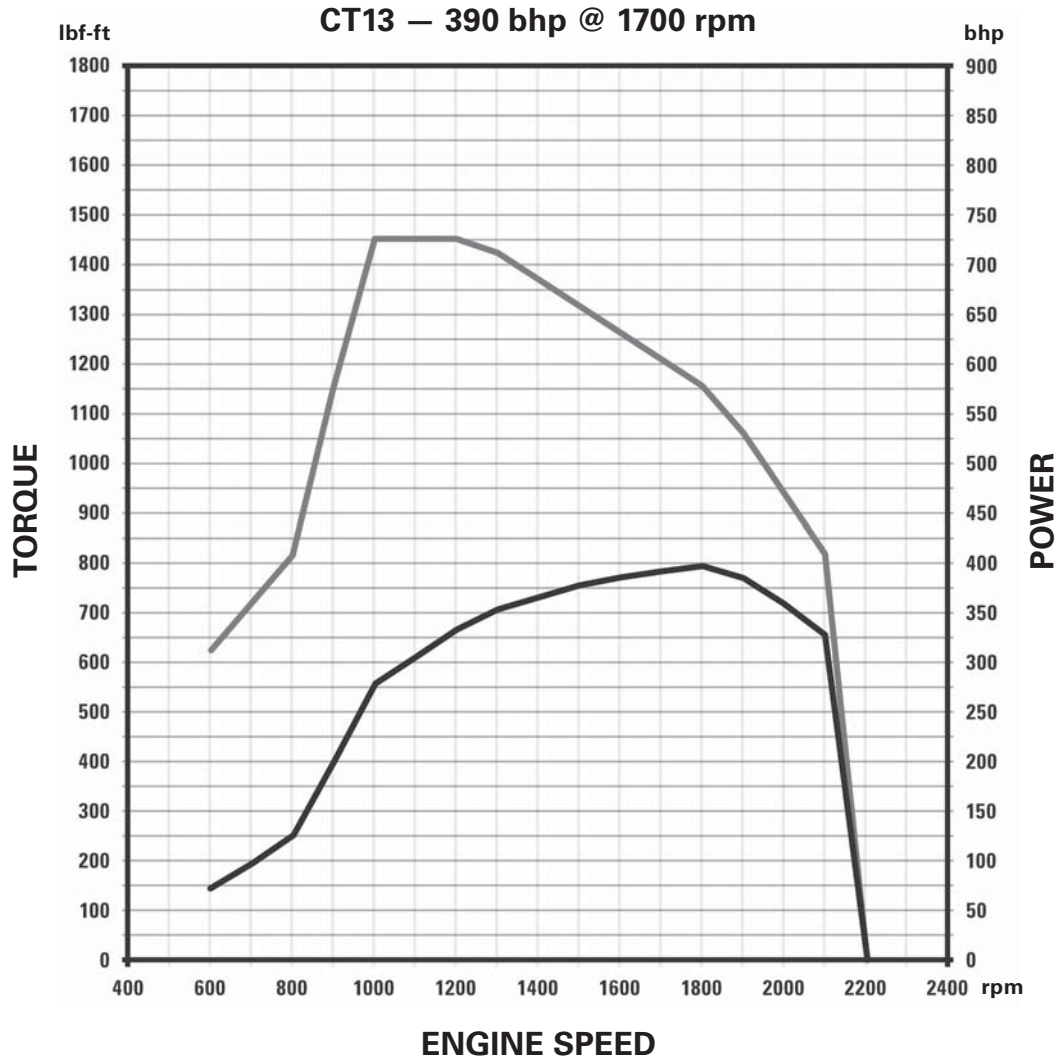

KEY
— Torque
— Power

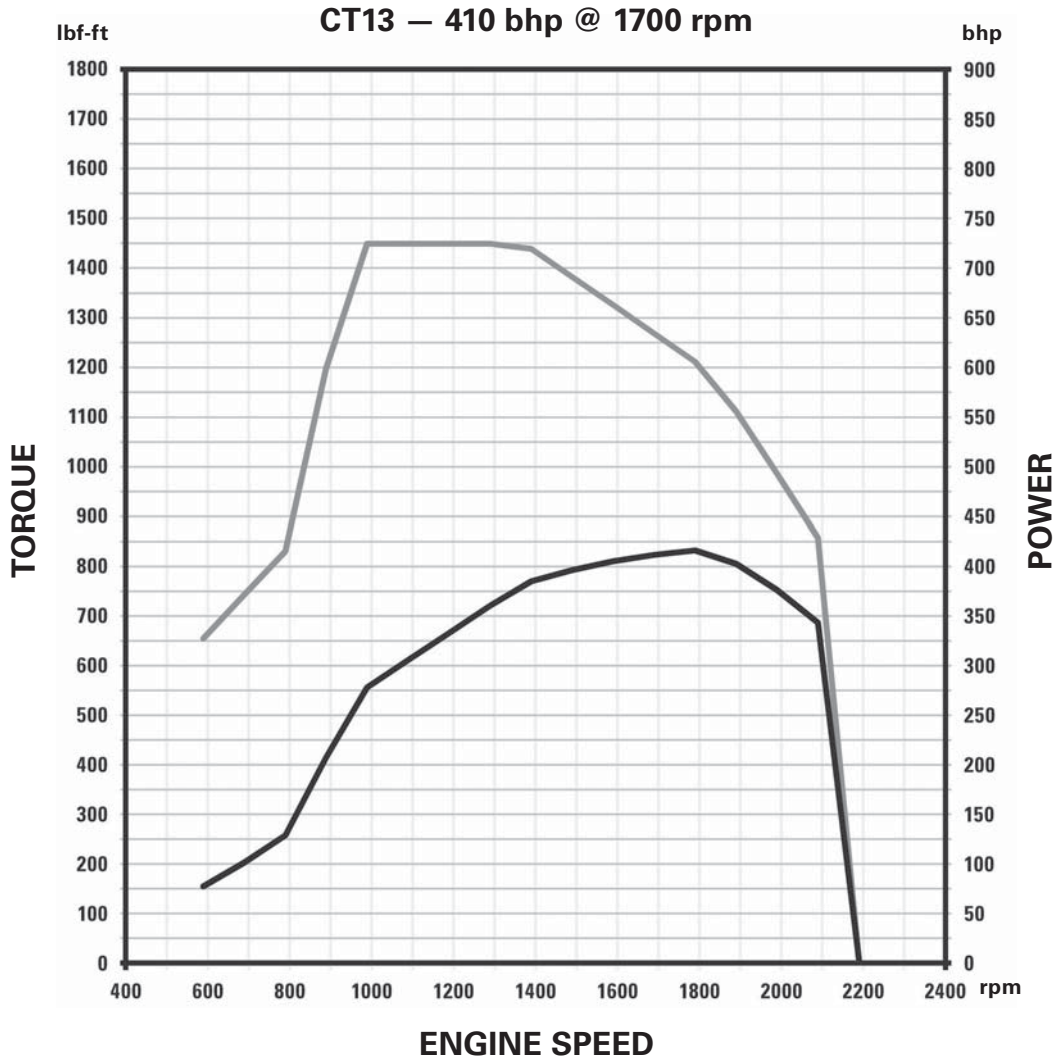

KEY
— Torque
— Power

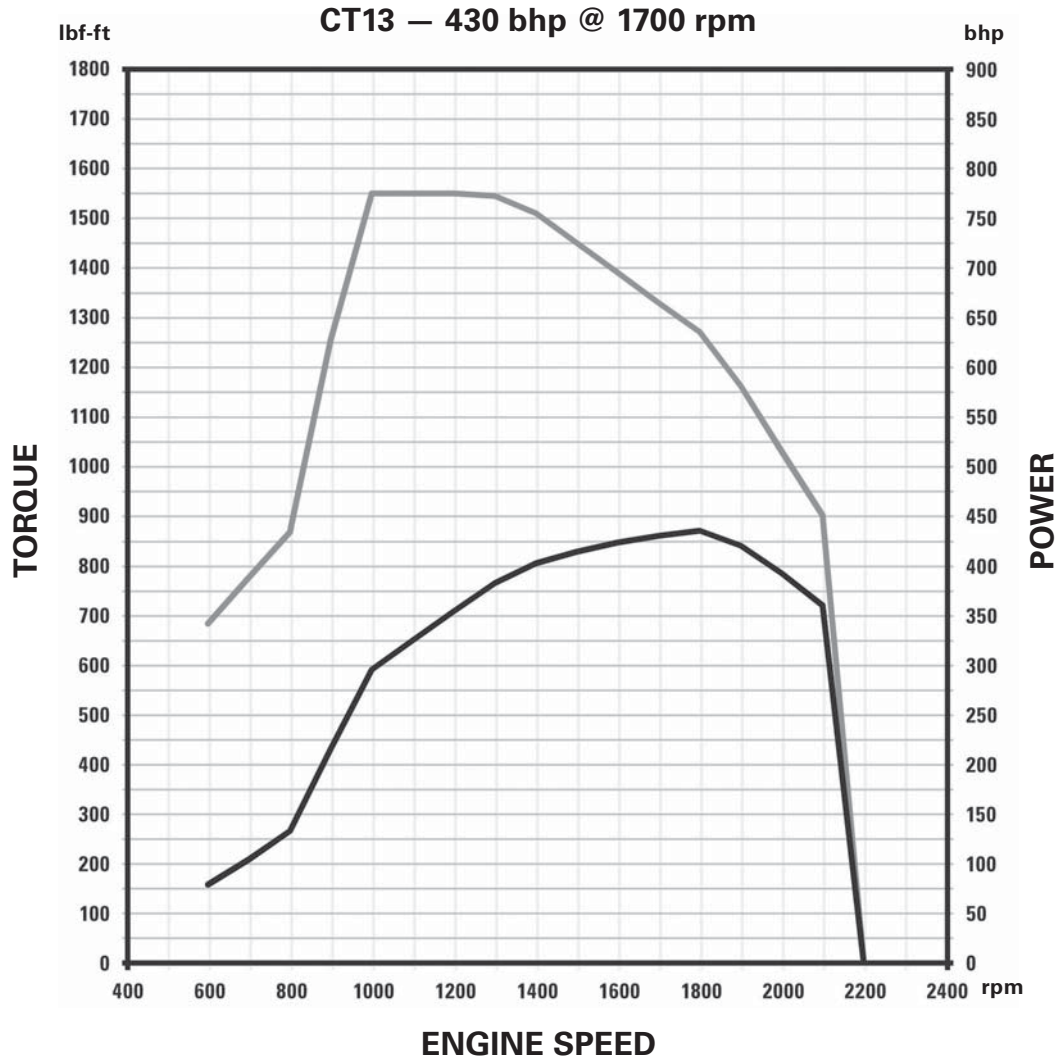

KEY
— Torque
— Power

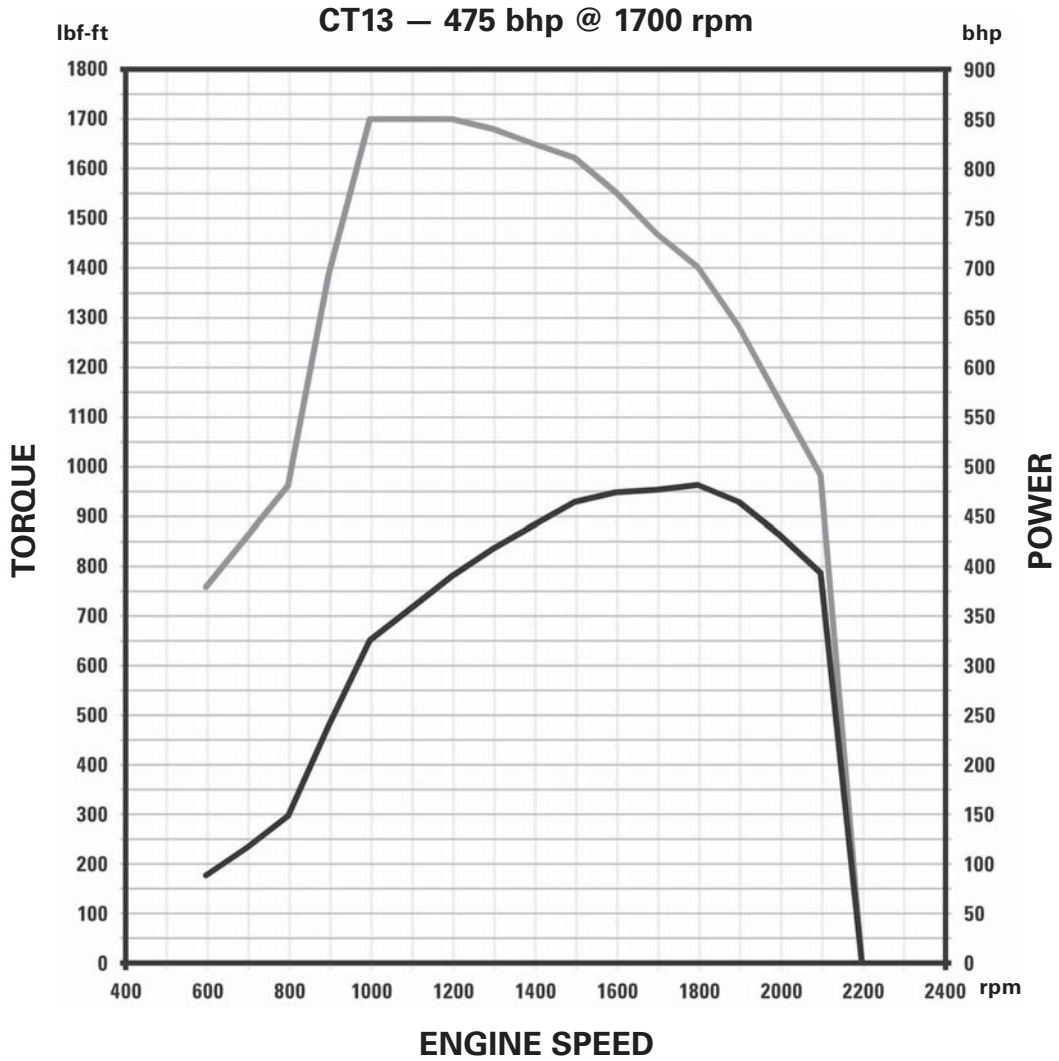

KEY
— Torque
— Power

Feature Code	Cat CX31 Automatic	Gear Ratios								Speeds	Rated lbf-ft	Gear Ratios												
		CT681 6x4 114 BBC	CT680 6x4 124 BBC	CT660 6x4 116 BBC	CT660 6x4 122 BBC	CT660 4x4 122 BBC	CT660 6x6 122 BBC	CT680 8x6 124 BBC	CT660 8x6 116 BBC			CT660 8x6 122 BBC	R4	R3	R2	R1	F1	F2	F3	F4	F5	F6		
0013CZY	CX31 with Retarder for CT13 Engines	x	x	x	x					x	x	x	6	1900				3.97	*4.4	*2.2	1.53	1.00	0.72	0.61
0013CZZ	CX31 for CT13 Engines	x	x	x	x	x	x	x	x	x	x	x	6	1900				3.97	*4.4	*2.2	1.53	1.00	0.72	0.61

*Multiply 1st and 2nd by 1.9 to account for torque converter.
 Torque converter locks up at 75% of 2nd gear speed range.

Feature Code	Eaton Manual Air Shift	Gear Ratios								Speeds	Rated lbf-ft	Gear Ratios											
		CT681 6x4 114 BBC	CT680 6x4 124 BBC	CT660 6x4 116 BBC	CT660 6x4 122 BBC	CT660 4x4 122 BBC	CT660 6x6 122 BBC	CT680 8x6 124 BBC	CT660 8x6 116 BBC			CT660 8x6 122 BBC	R4	R3	R2	R1	F1	F2	F3	F4	F5	F6	F7
0013GHC	Fuller FRO-13210C	x		x						x	10	1350			2.80	13.75	12.69	9.29	6.75	4.90	3.62	2.64	1.90
0013GHJ	Fuller FR-14210B	x	x	x	x	x					10	1450			2.72	12.12	11.06	8.19	6.05	4.46	3.34	2.48	1.83
0013GHL	Fuller FRO-14210C	x	x	x	x	x				x	10	1450			2.80	13.75	12.69	9.29	6.75	4.90	3.62	2.64	1.90
0013GHW	Fuller RTO(F)-14908LL	x	x	x	x	x	x				10	1450		2.89	9.85	15.22	14.56	9.42	6.24	4.63	3.40	2.53	1.83
0013GGV	Fuller FRO-12210C	x		x							10	1550			2.80	13.75	12.69	9.29	6.75	4.90	3.62	2.64	1.90
0013GHP	Fuller FRO-15210C	x	x	x	x			x	x	x	10	1550			2.80	13.75	12.69	9.29	6.75	4.90	3.62	2.64	1.90
0013GHS	Fuller FRO-16210C	x	x	x	x	x	x	x	x	x	10	1650			2.80	13.75	12.69	9.29	6.75	4.90	3.62	2.64	1.90
0013GHX	Fuller RTO(F)-16908LL	x	x	x	x	x	x				10	1650		2.89	9.85	15.22	14.56	9.42	6.24	4.63	3.40	2.53	1.83
0013GMZ	Fuller RTO(F)-14909ALL	x	x	x	x	x	x				11	1450		3.43	13.03	20.84	26.08	16.30	11.85	7.41	5.23	3.79	2.77
0013GNA	Fuller RTO(F)-16909ALL	x	x	x	x	x	x	x	x	x	11	1650		3.43	13.03	20.84	26.08	16.30	11.85	7.41	5.23	3.79	2.77
0013GRD	Fuller RTLO(F)-12913A	x	x	x	x	x	x				13	1250			3.50	13.22	12.31	8.64	6.11	4.43	3.23	2.29	1.95
0013GRE	Fuller RTLO(F)-14913A					x	x				13	1450			3.50	13.22	12.31	8.64	6.11	4.43	3.23	2.29	1.95
0013GKJ	Fuller RTLO(F)-16913A	x	x	x	x						13	1650			3.50	13.22	12.31	8.64	6.11	4.43	3.23	2.29	1.95
0013GJS	Fuller RTLO-18913A	x	x	x	x						13	1850			3.50	13.22	12.31	8.64	6.11	4.43	3.23	2.29	1.95
0013GHY	Fuller RTO(F)-16915	x	x	x	x			x	x	x	15	1650		2.17	7.73	13.14	13.31	10.20	7.88	6.07	4.77	7.83	6.00
0013GKL	Fuller RTLO(F)-16918B	x	x	x	x			x	x	x	18	1650	3.43	4.03	12.85	15.06	14.40	12.29	8.56	7.30	6.05	5.16	4.38
0013GKM	Fuller RTLO(F)-18918B	x	x	x	x			x	x	x	18	1850	3.43	4.03	12.85	15.06	14.40	12.29	8.56	7.30	6.05	5.16	4.38
0013GNM	Fuller RTLOF-20918B	x	x	x	x	x	x	x	x	x	18	2050	3.43	4.03	12.85	15.06	14.40	12.29	8.56	7.30	6.05	5.16	4.38

Chart continued on next page.

Appendix D
● Transmission Specifications

On-Highway Trucks

Feature Code	Eaton Manual Air Shift	CT681 6x4 114 BBC	CT680 6x4 124 BBC	CT660 6x4 116 BBC	CT660 6x4 122 BBC	CT660 4x4 122 BBC	CT660 6x6 122 BBC	CT680 8x6 124 BBC	CT660 8x6 116 BBC	CT660 8x6 122 BBC	Speeds	Rated lbf-ft	Gear Ratios										
													F8	F9	F10	F11	F12	F13	F14	F15	F16	F17	F18
0013GHC	Fuller FRO-13210C	x		x						x	10	1350	1.38	1.00	0.74								
0013GHJ	Fuller FR-14210B	x	x	x	x	x	x				10	1450	1.36	1.00	0.75								
0013GHL	Fuller FRO-14210C	x	x	x	x	x	x				10	1450	1.38	1.00	0.74								
0013GHW	Fuller RTO(F)-14908LL	x	x	x	x	x	x				10	1450	1.36	1.00	0.74								
0013GGV	Fuller FRO-12210C	x		x							10	1550	1.38	1.00	0.74								
0013GHP	Fuller FRO-15210C	x	x	x	x			x	x	x	10	1550	1.38	1.00	0.74								
0013GHS	Fuller FRO-16210C	x	x	x	x	x	x	x	x	x	10	1650	1.38	1.00	0.74								
0013GHX	Fuller RTO(F)-16908LL	x	x	x	x	x	x				10	1650	1.36	1.00	0.74								
0013GMZ	Fuller RTO(F)-14909ALL	x	x	x	x	x	x				11	1450	1.95	1.38	1.00	0.73							
0013GNA	Fuller RTO(F)-16909ALL	x	x	x	x	x	x	x	x	x	11	1650	1.95	1.38	1.00	0.73							
0013GRD	Fuller RTLO(F)-12913A	x	x	x	x	x	x				13	1250	1.62	1.38	1.17	1.00	0.86	0.73					
0013GRE	Fuller RTLO(F)-14913A					x	x				13	1450	1.62	1.38	1.17	1.00	0.86	0.73					
0013GKJ	Fuller RTLO(F)-16913A	x	x	x	x						13	1650	1.62	1.38	1.17	1.00	0.86	0.73					
0013GJS	Fuller RTLO-18913A	x	x	x	x						13	1850	1.62	1.38	1.17	1.00	0.86	0.73					
0013GHY	Fuller RTO(F)-16915	x	x	x	x			x	x	x	15	1650	4.63	3.57	2.81	2.19	1.68	1.30	1.00	0.79			
0013GKL	Fuller RTLO(F)-16918B	x	x	x	x			x	x	x	18	1650	3.74	3.20	2.73	2.29	1.95	1.62	1.38	1.17	1.00	0.86	0.73
0013GKM	Fuller RTLO(F)-18918B	x	x	x	x			x	x	x	18	1850	3.74	3.20	2.73	2.29	1.95	1.62	1.38	1.17	1.00	0.86	0.73
0013GNM	Fuller RTLOF-20918B	x	x	x	x	x	x	x	x	x	18	2050	3.74	3.20	2.73	2.29	1.95	1.62	1.38	1.17	1.00	0.86	0.73

Feature Code	Eaton UltraShift Plus Vocational Aluminum Clutch Housing, Hill Start Aid	CT681 6x4 114 BBC	CT680 6x4 124 BBC	CT660 6x4 116 BBC	CT660 6x4 122 BBC	CT660 4x4 122 BBC	CT660 6x6 122 BBC	CT680 8x6 124 BBC	CT660 8x6 116 BBC	CT660 8x6 122 BBC	Speeds	Rated lbf-ft	Gear Ratios										
													R4	R3	R2	R1	F1	F2	F3	F4	F5	F6	F7
0013GWM	FO-12E308LL-VCS	x	x						x	10	1250		2.89	9.85	15.22	14.56	9.42	6.24	4.63	3.40	2.53	1.83	
0013GWN	FO-14E308LL-VCS	x	x	x	x			x	x	x	10	1450	2.89	9.85	15.22	14.56	9.42	6.24	4.63	3.40	2.53	1.83	
0013GWE	FO-14E310C-VAS	x	x	x	x			x	x	x	10	1450			2.78	13.63	12.80	9.25	6.76	4.90	3.58	2.61	1.89
0013GWH	FOM-14E310C-VAS	x	x	x	x			x	x	x	10	1450			2.78	13.63	12.80	9.25	6.76	4.90	3.58	2.61	1.89
0013GWJ	FOM-15E310C-VAS	x	x	x	x			x	x	x	10	1550			2.78	13.63	12.80	9.25	6.76	4.90	3.58	2.61	1.89
0013GWP	FO-16E308LL-VCS	x	x	x	x			x	x	x	10	1650	2.89	9.85	15.22	14.56	9.42	6.24	4.63	3.40	2.53	1.83	
0013GWG	FO-16E310C-VAS	x	x	x	x			x	x	x	10	1650			2.78	13.63	12.80	9.25	6.76	4.90	3.58	2.61	1.89
0013GWL	FOM-16E310C-VAS	x	x	x	x			x	x	x	10	1650			2.78	13.63	12.80	9.25	6.76	4.90	3.58	2.61	1.89
0013GWR	FO-17E308LL-VCS	x	x	x	x			x	x	x	10	1750	2.89	9.85	15.22	14.56	9.42	6.24	4.63	3.40	2.53	1.83	
0013GWW	FO-14E309ALL-VMS	x	x	x	x			x	x	x	11	1450	3.43	13.03	20.84	26.08	16.30	11.85	7.41	5.23	3.79	2.77	
0013GWW	FO-16E309ALL-VMS	x	x	x	x			x	x	x	11	1650	3.43	13.03	20.84	26.08	16.30	11.85	7.41	5.23	3.79	2.77	
0013GWX	FO-17E309ALL-VMS	x	x	x	x	x	x	x	x	x	11	1750	3.43	13.03	20.84	26.08	16.30	11.85	7.41	5.23	3.79	2.77	
0013GWS	FO-16E313A-VHP	x	x	x	x			x	x	x	13	1650	4.03	12.85	15.06	12.29	8.51	6.05	4.38	3.20	2.28	1.94	
0013GWT	FO-18E313A-VHP	x	x	x	x			x	x	x	13	1850	4.03	12.85	15.06	12.29	8.51	6.05	4.38	3.20	2.28	1.94	
0013GUZ	FO-20E313A-VHP	x	x	x	x			x	x	x	13	2050	4.03	12.85	15.06	12.29	8.51	6.05	4.38	3.20	2.28	1.94	
0013GXE	FO-14E318B-VXP	x	x	x	x			x	x	x	18	1450	3.43	4.03	12.85	15.06	14.40	12.29	8.51	7.26	6.05	5.16	4.38
0013XG	FO-16E318B-VXP	x	x	x	x			x	x	x	18	1650	3.43	4.03	12.85	15.06	14.40	12.29	8.51	7.26	6.05	5.16	4.38
0013GXD	FO-18E318B-MXP			x							18	1850	3.43	4.03	12.85	15.06	14.40	12.29	8.51	7.26	6.05	5.16	4.38
0013GXH	FO-18E318B-VXP	x	x	x	x			x	x	x	18	1850	3.43	4.03	12.85	15.06	14.40	12.29	8.51	7.26	6.05	5.16	4.38

Chart continued on next page.

Appendix D
● Transmission Specifications

On-Highway Trucks

Feature Code	Eaton UltraShift Plus Vocational Aluminum Clutch Housing, Hill Start Aid	CT681 6x4 114 BBC	CT680 6x4 124 BBC	CT660 6x4 116 BBC	CT660 6x4 122 BBC	CT660 4x4 122 BBC	CT660 6x6 122 BBC	CT680 8x6 124 BBC	CT660 8x6 116 BBC	CT660 8x6 122 BBC	Speeds	Rated lbf-ft	Gear Ratios											
													F8	F9	F10	F11	F12	F13	F14	F15	F16	F17	F18	
0013GWM	FO-12E308LL-VCS	x		x						x	10	1250	1.36	1.00	0.74									
0013GWN	FO-14E308LL-VCS	x	x	x	x				x	x	x	10	1450	1.36	1.00	0.74								
0013GWE	FO-14E310C-VAS	x	x	x	x				x	x	x	10	1450	1.38	1.00	0.73								
0013GWH	FOM-14E310C-VAS	x	x	x	x				x	x	x	10	1450	1.38	1.00	0.73								
0013GWJ	FOM-15E310C-VAS	x	x	x	x				x	x	x	10	1550	1.38	1.00	0.73								
0013GWP	FO-16E308LL-VCS	x	x	x	x				x	x	x	10	1650	1.36	1.00	0.74								
0013GWG	FO-16E310C-VAS	x	x	x	x				x	x	x	10	1650	1.38	1.00	0.73								
0013GWL	FOM-16E310C-VAS	x	x	x	x				x	x	x	10	1650	1.38	1.00	0.73								
0013GWR	FO-17E308LL-VCS	x	x	x	x				x	x	x	10	1750	1.36	1.00	0.74								
0013GWW	FO-14E309ALL-VMS	x	x	x	x				x	x	x	11	1450	1.95	1.38	1.00	0.73							
0013GWW	FO-16E309ALL-VMS	x	x	x	x				x	x	x	11	1650	1.95	1.38	1.00	0.73							
0013GWX	FO-17E309ALL-VMS	x	x	x	x	x	x		x	x	x	11	1750	1.95	1.38	1.00	0.73							
0013GWS	FO-16E313A-VHP	x	x	x	x				x	x	x	13	1650	1.62	1.38	1.17	1.00	0.86	0.73					
0013GWT	FO-18E313A-VHP	x	x	x	x				x	x	x	13	1850	1.62	1.38	1.17	1.00	0.86	0.73					
0013GUZ	FO-20E313A-VHP	x	x	x	x				x	x	x	13	2050	1.62	1.38	1.17	1.00	0.86	0.73					
0013GXE	FO-14E318B-VXP	x	x	x	x				x	x	x	18	1450	3.74	3.20	2.73	2.28	1.94	1.62	1.38	1.17	1.00	0.86	0.73
0013GXG	FO-16E318B-VXP	x	x	x	x				x	x	x	18	1650	3.74	3.20	2.73	2.28	1.94	1.62	1.38	1.17	1.00	0.86	0.73
0013GXD	FO-18E318B-MXP			x								18	1850	3.74	3.20	2.73	2.28	1.94	1.62	1.38	1.17	1.00	0.86	0.73
0013GXH	FO-18E318B-VXP	x	x	x	x				x	x	x	18	1850	3.74	3.20	2.73	2.28	1.94	1.62	1.38	1.17	1.00	0.86	0.73

Feature Code	Auxiliary Transmission and Transfer Case	CT681 6x4 114 BBC	CT680 6x4 124 BBC	CT660 6x4 116 BBC	CT660 6x4 122 BBC	CT660 4x4 122 BBC	CT660 6x6 122 BBC	CT680 8x6 124 BBC	CT660 8x6 116 BBC	CT660 8x6 122 BBC	Speeds	Rated lbf-ft	Gear Ratios										
													R4	R3	R2	R1	F1	F2					
0013TJP	TC-270 Fabco Transfer Case					x	x				2	12,000									1.00	2.23	
0013TJG	TC-142 Fabco Transfer Case					x	x				2	14,000										1.00	2.23
0013TKJ	TC-142 Fabco Transfer Case						x				2	14,000										1.00	2.23
0013TLC	TC-180 Fabco Transfer Case					x	x				1	15,000										1.00	
0013607	AT-1202 Aux Transmission, Eaton 2-Speed with Air Shift Controls	x	x	x	x				x	x	x	2	17,500									1.00	2.04

Feature Code	Description	CT681 6x4 114 BBC	CT680 6x4 124 BBC	CT660 6x4 116 BBC	CT660 6x4 122 BBC	CT660 4x4 122 BBC	CT660 6x6 122 BBC	CT680 8x6 124 BBC	CT660 8x6 116 BBC	CT660 8x6 122 BBC	Meritor/Spicer	Load Rating (lb)	Locking Diff Rear/ Mid/Forward	Lube Pump	Wheel Ends
Single Drive Axles															
0014051	RS-23-160					x					M	23,000			200
0014ARB	RS-23-160					x					M	23,000	R		200
0014ARK	RS-23-161					x					M	23,000	R		R
0014AHE	S23-190 Hypoid					x					S	23,000			R
0014AHG	S23-190D Hypoid					x					S	23,000	R		R
0014ARZ	RS-26-185 Standard Track					x					M	26,000			R
0014ASA	RS-26-185 Standard Track					x					M	26,000	R		R
0014ATN	RS-26-185 Wide Track					x					M	26,000	R		R
0014ASB	RS-30-185 Standard Track					x					M	30,000			T
0014ASD	RS-30-185 Standard Track					x					M	30,000	R		T
0014ERB	RS-30-380 Double Reduction					x					M	30,000			T
Tandem Drive Axles															
0014GGC	DD405/RD405	x	x	x	x						S	40,000	RF		200
0014GGD	DD405P/RD405	x	x	x	x						S	40,000	RF	Y	200
0014GJD	DST41/RST41	x	x	x	x						S	40,000			200
0014GJE	DST41P/RST41 0.44" Wall Housing	x	x	x	x						S	40,000		Y	200
0014GVJ	MT-40-A144 Vocational	x	x	x	x			x			M	40,000	R	Y	R
0014GVK	MT-40-A145 Vocational	x	x	x	x			x			M	40,000	R	Y	R
0014GVL	MT-40-A144	x	x								M	40,000	RF	Y	R
0014GVM	MT-40-A145 Vocational	x	x	x	x						M	40,000	RF	Y	R
0014GVN	MT-40-A144 Vocational	x	x	x	x			x			M	40,000	RF		R
0014GVR	MT-40-A144 Vocational	x	x	x	x			x			M	40,000	R		R
0014GVU	MT-40-14X-4DFR-P 0.433" Wall Housing Thickness	x	x	x	x			x			M	40,000		Y	R
0014GVY	MT-40-A144 Vocational	x	x	x	x			x			M	40,000			R
0014GVZ	MT-40-A145 Vocational	x	x	x	x			x			M	40,000			R
0014HRU	RT-44-145 Heavy Wall Housing	x	x	x	x			x			M	44,000	RF		200
0014GGU	DT463P/RT463 Two-Speed 18" Ring Gear	x	x	x	x						S	46,000			200
0014GJH	D46-170HP/R46-170H	x	x	x	x			x			S	46,000		Y	R
0014GJJ	D46-170HP/R46-170DH	x	x	x	x			x			S	46,000	R	Y	R
0014GJK	D46-170DHP/R46-170DH	x	x	x	x			x			S	46,000	RF	Y	R
0014GJN	D46-170DP/R46-170D	x	x	x	x						S	46,000	RF	Y	R
0014GRD	RT-46-160	x	x	x	x			x			M	46,000			200
0014GRP	RT-46-160	x	x	x	x			x			M	46,000	R		200
0014GRR	RT-46-160P	x	x	x	x						M	46,000		Y	200
0014GRS	RT-46-160P	x	x	x	x			x			M	46,000	R	Y	200
0014HRA	RT-46-164EH Wide Track	x	x	x	x			x			M	46,000	RF		200
0014HRC	RT-46-164EH Standard Width	x	x	x	x			x			M	46,000	RF		200
0014HRE	RT-46-164P Standard Width	x	x	x	x			x			M	46,000	RF	Y	200
0014HRH	RT-46-164P Wide Track	x	x	x	x			x			M	46,000	RF	Y	200
0014HRL	RT-46-160P	x	x	x	x			x			M	46,000	RF	Y	200
0014HRM	RT-46-160	x	x	x	x			x			M	46,000	RF		200
0014HRW	RT-46-164P	x	x	x	x						S	46,000		Y	R
0014GTS	RT-52-185	x	x	x	x			x			M	52,000		Y	R
0014GTW	RT-52-185P	x	x	x	x						M	52,000	R	Y	R
0014GUV	RT-52-185P	x	x	x	x						M	52,000	R	Y	T
0014GRJ	RT-58-380 Double Reduction Standard Track 74"	x	x	x	x						M	58,000			T
0014GTT	RT-58-185	x	x	x	x						M	58,000		Y	T
0014GTU	RT-58-185	x	x	x	x			x			M	58,000	R	Y	T
0014GRM	RT-70-380 Double Reduction Standard Track 73.75"	x	x	x	x			x			M	70,000			W
Tridem Drive Axles															
0014HRG	RZ-166 EH Wide Track							x	x	x	M	53,000	RMF		200

Axles are Single Reduction unless otherwise noted.

Appendix E ● Rear Axle Specifications

On-Highway Trucks

Feature Code

Axle Ratios

Single Drive Axles																								
0014051					3.07	3.21	3.42	3.58	3.73	3.91	4.10	4.30	4.56	4.89	5.38	5.63	6.14	6.43	6.83	7.17				
0014ARB					3.07	3.21	3.42	3.58	3.73	3.91	4.10	4.30	4.56	4.89	5.38	5.63	6.14	6.43	6.83	7.17				
0014ARK	2.50	2.67	2.80	2.93	3.08	3.21	3.42	3.58	3.73	3.91	4.10	4.30	4.56	4.89	5.38	5.63	6.14	6.43	6.83	7.17				
0014AHE		2.69	2.87	2.93	3.07	3.21	3.42	3.58	3.73	3.91	4.10	4.30		4.78	5.25	5.38	5.63	6.14	6.83	7.17		7.83		
0014AHG		2.69	2.87	2.93	3.07	3.21	3.42	3.58	3.73	3.91	4.10	4.30		4.78	5.25	5.38	5.63	6.14	6.83	7.17		7.83		
0014ARZ				2.93	3.08	3.21	3.42	3.58	3.73	3.91	4.10	4.30	4.56	4.89	5.13	5.38	5.63	5.86	6.14	6.83	7.17	7.40		
0014ASA				2.93	3.08	3.21	3.42	3.58	3.73	3.91	4.10	4.30	4.56	4.89	5.13	5.38	5.63	5.86	6.14	6.83	7.17	7.40		
0014ATN				2.93	3.08	3.21	3.42	3.58	3.73	3.91	4.10	4.30	4.56	4.89	5.13	5.38	5.63	5.86	6.14	6.83	7.17	7.40		
0014ASB				2.93	3.08	3.21	3.42	3.58	3.73	3.91	4.10	4.30	4.56	4.89	5.13	5.38	5.63	5.86	6.14	6.83	7.17	7.40		
0014ASD				2.93	3.08	3.21	3.42	3.58	3.73	3.91	4.10	4.30	4.56	4.89	5.13	5.38	5.63	5.86	6.14	6.83	7.17	7.40		
0014ERB				2.93	3.08	3.21	3.42	3.58	3.73	3.91	4.10	4.30	4.56	4.89	5.13	5.38	5.63	5.86	6.14	6.83	7.17	7.40		
Tandem Drive Axles																								
0014GGC		2.64	2.85	2.93	3.08	3.25	3.36	3.36	3.55	3.70	3.90	4.11	4.33	4.63	4.88	5.29	5.57	6.17	6.50	7.17				
0014GGD		2.64	2.85	2.93	3.08	3.25	3.36	3.36	3.55	3.70	3.90	4.11	4.33	4.63	4.88	5.29	5.57	6.17	6.50	7.17				
0014GJD		2.64			3.08	3.25	3.36		3.55	3.70	3.90	4.11	4.33											
0014GJE		2.64			3.08	3.25	3.36		3.55	3.70	3.90	4.11	4.33											
0014GVJ	2.47	2.64			3.08	3.25	3.36	3.55	3.70	3.90	4.11	4.33	4.63	4.88	5.29	5.86	6.14	6.43	6.83	7.17				
0014GVK	2.47	2.64			3.08	3.25	3.36	3.55	3.70	3.90	4.11	4.33	4.63	4.88	5.29	5.86	6.14	6.43	6.83	7.17				
0014GVL	2.47	2.64			3.08	3.25	3.36	3.55	3.70	3.90	4.11	4.33	4.63	4.88	5.29	5.86	6.14	6.43	6.83	7.17				
0014GVM	2.47	2.64			3.08	3.25	3.36	3.55	3.70	3.90	4.11	4.33	4.63	4.88	5.29	5.86	6.14	6.43	6.83	7.17				
0014GVN	2.47	2.64			3.08	3.25	3.36	3.55	3.70	3.90	4.11	4.33	4.63	4.88	5.29	5.86	6.14	6.43	6.83	7.17				
0014GVR	2.47	2.64			3.08	3.25	3.36	3.55	3.70	3.90	4.11	4.33	4.63	4.88	5.29	5.86	6.14	6.43	6.83	7.17				
0014GVU	2.47	2.64			3.08	3.25	3.36	3.55	3.70	3.90	4.11													
0014GVY	2.47	2.64			3.08	3.25	3.36	3.55	3.70	3.90	4.11	4.33	4.63	4.88	5.29	5.86	6.14	6.43	6.83	7.17				
0014GVZ	2.47	2.64			3.08	3.25	3.36	3.55	3.70	3.90	4.11	4.33	4.63	4.88	5.29	5.86	6.14	6.43	6.83	7.17				
0014HRU							3.42	3.58	3.73	3.91	4.10	4.30	4.56	4.89	5.38	5.63	6.14	6.43	6.83	7.17				
0014GGU		3.7/5.04		4.56/6.20	3.90/5.31		4.88/6.64		4.11/5.60	5.43/7.39	4.33/5.91		6.17/8.40											
0014GJH					3.07	3.21	3.42		3.58	3.73	3.91	4.10	4.30	4.56	4.78	5.25	5.38	5.57	6.14	6.83	7.17			
0014GJJ					3.07	3.21	3.42		3.58	3.73	3.91	4.10	4.30	4.56	4.78	5.25	5.38	5.57	6.14	6.83	7.17			
0014GJK					3.07	3.21	3.42		3.58	3.73	3.91	4.10	4.30	4.56	4.78	5.25	5.38	5.57	6.14	6.83	7.17			
0014GJN					3.07	3.21	3.42		3.58	3.73	3.91	4.10	4.30	4.56	4.78	5.25	5.38	5.57	6.14	6.83	7.17			
0014GRD							3.42	3.58	3.73	3.91	4.10	4.30	4.56	4.89	5.38	5.63	6.14	6.43	6.83	7.17				
0014GRP							3.42	3.58	3.73	3.91	4.10	4.30	4.56	4.89	5.38	5.63	6.14	6.43	6.83	7.17				
0014GRR							3.42	3.58	3.73	3.91	4.10	4.30	4.56	4.89	5.38	5.63	6.14	6.43	6.83	7.17				
0014GRS							3.42	3.58	3.73	3.91	4.10	4.30	4.56	4.89	5.38	5.63	6.14	6.43	6.83	7.17				
0014HRA							3.42	3.58	3.73	3.91	4.10	4.30	4.56	4.89	5.38	5.63	6.14	6.43	6.83	7.17				
0014HRC							3.42	3.58	3.73	3.91	4.10	4.30	4.56	4.89	5.38	5.63	6.14	6.43	6.83	7.17				
0014HRE							3.42	3.58	3.73	3.91	4.10	4.30	4.56	4.89	5.38	5.63	6.14	6.43	6.83	7.17				
0014HRH							3.42	3.58	3.73	3.91	4.10	4.30	4.56	4.89	5.38	5.63	6.14	6.43	6.83	7.17				
0014HRL							3.42	3.58	3.73	3.91	4.10	4.30	4.56	4.89	5.38	5.63	6.14	6.43	6.83	7.17				
0014HRM							3.42	3.58	3.73	3.91	4.10	4.30	4.56	4.89	5.38	5.63	6.14	6.43	6.83	7.17				
0014HRW							3.42		3.58	3.73	3.91	4.10	4.30	4.56	4.89	5.38	5.63	6.14	6.43	6.83	7.17			
0014GTS									3.73		4.10	4.30		4.89	5.38		6.14	6.83	7.17					
0014GTW									3.73		4.10	4.30		4.89	5.38		6.14	6.83	7.17					
0014GUV									3.73		4.10	4.30		4.89	5.38		6.14	6.83	7.17					
0014GRJ																5.52	6.07	6.37	6.75	7.24	7.83	9.14	10.12	10.62
0014GTT									3.73		4.10	4.30		4.89	5.38		6.14	6.83	7.17					
0014GTU									3.73		4.10	4.30		4.89	5.38		6.14	6.83	7.17					
0014GRM																5.52	6.07	6.37	6.75	7.24	7.83	9.14	10.12	10.62
Tridem Drive Axles																								
0014HRG					3.42	3.58	3.73	3.91	4.10	4.30	4.56	4.89	5.38	5.63	6.14	6.43	6.83	7.17						

Axles are Single Reduction unless otherwise noted.

- Front Axle Specifications
- Lift Axle Specifications

Feature Code	Description											Single Reduction	Load Rating (lb)	Axle Ratios													
		CT681 6x4 114 BBC	CT680 6x4 124 BBC	CT660 6x4 116 BBC	CT660 6x4 122 BBC	CT660 4x4 122 BBC	CT660 6x6 122 BBC	CT680 8x6 124 BBC	CT660 8x6 116 BBC	CT660 8x6 122 BBC																	
Front Drive Axles																											
0002EYU	Fabco SDA-1800 Hub Piloted					x	x					Y	18,000			3.90	4.11	4.33	4.56	4.88	5.29			5.57	6.14	6.57	7.17
0002EYV	Fabco SDA-2100 Hub Piloted					x	x					Y	21,000			3.90	4.11	4.33	4.56	4.88	5.29			5.57	6.14	6.57	7.17
0002EYN	Fabco SDA-2300					x	x					Y	23,000	3.55	3.70	3.90	4.11	4.33	4.56	4.88	5.29	5.43		6.17	6.50	6.67	

Feature Code	Description											I-Beam	Load Rating (lb)	Wide Track	Meritor/Spicer	
		CT681 6x4 114 BBC	CT680 6x4 124 BBC	CT660 6x4 116 BBC	CT660 6x4 122 BBC	CT660 4x4 122 BBC	CT660 6x6 122 BBC	CT680 8x6 124 BBC	CT660 8x6 116 BBC	CT660 8x6 122 BBC						
Front Non Drive Axles																
0002ARA	FF-961	x										Y	12,000			M
0002ARW	MFS-12-143A		x	x	x							Y	12,000	Y	M	
0002227	FF-942	x										y	13,200		M	
0002ASG	MFS-13-143A		x	x	x							Y	13,200	Y	M	
0002ARG	FG-941	x										Y	14,600		M	
0002ASM	MFS-14-143A		x	x	x							Y	14,600	Y	M	
0002231	FL-941	x										y	16,000		M	
0002AEU	I-160W			x	x					x	x	Y	16,000	Y	S	
0002ARU	MFS-16-143A		x	x	x			x	x	x	Y	16,000	Y	M		
0002AUR	MFS-16-133A		x	x	x			x	x	x	Y	16,000	Y	M		
0002AYL	D-2000W			x	x					x	x	Y	16,000	Y	S	
0002232	FL-941	x										y	18,000		M	
0002AEV	I-180W			x	x					x	x	Y	18,000	Y	S	
0002ARZ	MFS-18-133A		x	x	x			x	x	x	Y	18,000	Y	M		
0002AYK	D-2000W			x	x					x	x	Y	18,000	Y	S	
0002233	FL-941	x										y	20,000		M	
0002AEW	I-200W			x	x					x	x	Y	20,000	Y	S	
0002ARY	MFS-20-133A		x	x	x			x	x	x	Y	20,000	Y	M		
0002AYJ	D-2000W			x	x					x	x	Y	20,000	Y	S	
0002AGT	I-220W			x	x					x	x	Y	22,000	Y	S	
0002ATB	MFS-20-133A			x	x					x	x	Y	22,000	Y	M	

Feature Code	Description	CT660 6x4 116 BBC	CT660 6x4 122 BBC	CT680 6x4 124 BBC	CT681 6x4 114 BBC	Capacity (lb)	Pusher/Tag
		Lift Axles					
0014WML	Watson and Chalin SL-0893 Tru Track includes Three Self-Steer Axles			x	x	8000	P
0014WMA	Watson and Chalin SL1190 Tru Track Alumilite includes One Self-Steer Axle	x	x	x	x	13,200	P
0014WMB	Watson and Chalin SL1190 Tru Track Alumilite includes Two Self-Steer Axles	x	x	x	x	13,200	P
0014WLM	Watson and Chalin AL-2200 includes One Non-Steer Axle	x	x	x	x	20,000	P
0014WMM	Watson and Chalin SL-2050 Tru Track includes One Self-Steer Axle	x	x	x	x	20,000	P
0014WMC	Watson and Chalin SL1190 Tru Track Alumilite includes One Self-Steer Axle	x	x	x	x	13,200	T
0014WLR	Watson and Chalin AL-2200 includes One Non-Steer Axle	x	x	x	x	20,000	T

CX31 Startability Reference Guide (for Common GVWR/GCCR and Axle Ratios)

Maximum Startability (% Grade) at given weight for the most common Axle Ratios: 4.56, 4.89, and 5.38

Tire Revs/Mile = 488

Engine	HP/Torque	60,000 lb GVWR/GCCR			70,000 lb GVWR/GCCR			80,000 lb GVWR/GCCR			90,000 lb GVWR/GCCW		
		4.56	4.89	5.38	4.56	4.89	5.38	4.56	4.89	5.38	4.56	4.89	5.38
CT13	365/1250	22.9	24.8	27.5	19.5	21.0	23.3	16.9	18.2	20.2	14.9	16.1	17.7
CT13	370/1350	23.4	25.2	28.0	19.8	21.3	23.6	17.2	18.5	20.5	15.1	16.3	18.0
CT13	390/1450	24.0	25.9	28.8	20.3	21.9	24.3	17.6	19.0	21.0	15.6	16.8	18.5
CT13	410/1450	29.5	31.9	35.5	24.9	26.9	29.9	21.6	23.2	25.8	19.0	20.5	22.6
CT13	430/1550	30.7	33.2	37.0	25.9	27.9	31.1	22.4	24.2	26.8	19.7	21.3	23.5
CT13	475/1700	33.3	36.0	40.3	28.0	30.3	33.7	24.2	26.1	29.0	21.3	23.0	25.4

If your Truck is outside the weight or axle ratios specified above, please contact the Truck Coordinator at your Cat dealer for assistance. Other options are available.

Feature	Size	Description	Manufacturer	Rev/Mile	Load Range	Ply	Maximum Load Single (lb)	Unloaded Diameter (in)	Application
7372130524	11R22.5	S581	GENERAL	500	G	14	6175	41.4	Long haul, over-the-highway steering and all-position use
7372135414	11R22.5	HSL2	CONTINENTAL	500	G	14	6175	41.4	Long haul, over-the-highway steering and all-purpose use
7372135415	11R22.5	HSR2	CONTINENTAL	498	G	14	6175	41.6	Regional hauling and on/off road, all-position
7372138107	11R22.5	G661 HAS	GOODYEAR	497	G	14	6175	41.8	Enhanced toughness for high-scrub applications
7372138108	11R22.5	G662 FUEL MAX	GOODYEAR	497	G	14	6175	41.8	Long tread life and toughness for regional highway and local driving
7372138116	11R22.5	G399 LHS FUEL MAX	GOODYEAR	504	G	14	6175	41.2	Long haul/regional steer fuel efficiency combined with long mileage
7472133208	11R22.5	XZY-3	MICHELIN	496	G	14	6175	41.8	All-position radial designed for exceptional wear and traction in mixed on/off road service
7472133269	11R22.5	XZE2	MICHELIN	501	G	14	6175	41.3	Regional, all-position radial with extra-wide, extra-deep tread designed to help deliver best wear in high scrub applications
7382130125	11R22.5	G287 MSA	GOODYEAR	498	H	16	6610	41.7	Superior over-the-road performance
7382130126	11R22.5	G288 MSA	GOODYEAR	498	H	16	6610	41.9	Outstanding performance in off-highway rough road conditions
7382135413	11R22.5	HDO	CONTINENTAL	490	H	16	6610	42.4	Logging, mining, construction and other aggressive, off-road traction needs
7382135419	11R22.5	HSC1	CONTINENTAL	496	H	16	6610	41.7	Coal haulers, logging, construction, waste haulers, and other all-position service
7382135420	11R22.5	HDC1	CONTINENTAL	488	H	16	6610	42.4	Coal haulers, logging, construction, waste haulers, school buses and other on/off highway service
7382138103	11R22.5	G287 MSA DURASEAL	GOODYEAR	498	H	16	6610	41.7	Puncture-sealing* superior over-the-road performance
7482133208	11R22.5	XZY-3	MICHELIN	496	H	16	6610	41.8	All-position radial designed for exceptional wear and traction in mixed on/off road service
7482133269	11R22.5	XZE2	MICHELIN	501	H	16	6610	41.4	Regional, all-position radial with extra-wide, extra-deep tread designed to help deliver best wear in high scrub applications
7374228116	11R24.5	G399 LHS FUEL MAX	GOODYEAR	481	G	14	6610	43.2	Long haul/regional steer fuel efficiency combined with long mileage
7474223268	11R24.5	XZA3+	MICHELIN	479	G	14	6610	43.3	Ultra-fuel-efficient radial that delivers long original tread life in long haul steer service
7474223269	11R24.5	XZE2	MICHELIN	476	G	14	6610	43.5	Regional, all-position radial with extra-wide, extra-deep tread designed to help deliver best wear in high scrub applications
7384220125	11R24.5	G287 MSA	GOODYEAR	475	H	16	7160	43.7	Superior over-the-road performance
7384220162	11R24.5	UNISTEEL G177	GOODYEAR	471	H	16	7160	44.3	Seals tread punctures* and is for rugged off-road conditions like coal fields
7384225415	11R24.5	HSR2	CONTINENTAL	476	H	16	7160	43.5	Regional hauling and on/off road, all-position

All tires listed are radials.

Availability can change without warning.

*Seals up to ¼" diameter punctures in the repairable area of the tread. Does not seal sidewall punctures.

Appendix H ● Front Tire Specifications

On-Highway Trucks

Feature	Size	Description	Manufacturer	Rev/Mile	Load Range	Ply	Maximum Load Single (lb)	Unloaded Diameter (in)	Application
7384228108	11R24.5	G662 FUEL MAX	GOODYEAR	497	H	16	6610	41.8	Long tread life and toughness for regional highway and local driving
6354060162	1200R24	UNISTEEL G177	GOODYEAR	423	J	18	9370	49.4	Seals tread punctures* and is for rugged off-road conditions like coal fields
7382150125	12R22.5	G287 MSA	GOODYEAR	482	H	16	7390	43.1	Superior over-the-road performance
7382150162	12R22.5	UNISTEEL G177	GOODYEAR	478	H	16	7390	43.7	Seals tread punctures* and is for rugged off-road conditions like coal fields
7382155419	12R22.5	HSC1	CONTINENTAL	482	H	16	7390	43.0	Coal haulers, logging, construction, waste haulers, and other all-position service
7382158103	12R22.5	G287 MSA DURASEAL	GOODYEAR	482	H	16	7390	43.1	Puncture-sealing* superior over-the-road performance
7382158107	12R22.5	G661 HAS	GOODYEAR	484	H	16	7390	42.9	Enhanced toughness for high-scrub applications
7422153253	12R22.5	XZE	MICHELIN	486	H	16	7390	42.6	All-position radial with extra-wide, extra-deep tread designed to help deliver best wear in high scrub applications
7482153208	12R22.5	XZY-3	MICHELIN	483	H	16	7390	42.9	All-position radial designed for exceptional wear and traction in mixed on/off road service
7384240125	12R24.5	G287 MSA	GOODYEAR	463	H	16	7830	44.9	Superior over-the-road performance
7384240162	12R24.5	UNISTEEL G177	GOODYEAR	457	H	16	7830	45.7	Seals tread punctures* and is for rugged off-road conditions like coal fields
7484243208	12R24.5	XZY-3	MICHELIN	461	H	16	7830	44.9	All-position radial designed for exceptional wear and traction in mixed on/off road service
7652543208	315/80R22.5	XZY-3	MICHELIN	486	L	20	9090	42.9	All-position radial designed for exceptional wear and traction in mixed on/off road service
7682543212	315/80R22.5	XZU-S2	MICHELIN	488	L	20	10,000	42.8	All-position tire with high carrying capacity designed for exceptional tread life in high scrub urban applications such as refuse vehicles
7782548109	315/80R22.5	G289 WHA	GOODYEAR	484	L	20	10,200	43.1	Offers a 68 MPH speed rating and helps provide outstanding performance in waste haul applications
7792545416	315/80R22.5	HSU2+	CONTINENTAL	481	L	20	10,000	43.0	Waste haulers, construction and other on/off highway service
7602653208	385/65R22.5	XZY-3	MICHELIN	491	J	18	9370	42.4	All-position radial designed for exceptional wear and traction in mixed on/off road service
7652663208	425/65R22.5	XZY-3	MICHELIN	465	L	20	11,400	44.7	All-position radial designed for exceptional wear and traction in mixed on/off road service
7652663267	425/65R22.5	XZL	MICHELIN	467	L	20	11,400	44.8	All-terrain, all-position radial for special service such as Emergency Response vehicles
7752665412	425/65R22.5	HTC1	CONTINENTAL	465	L	20	11,400	44.5	Super single fitment for steer and trailer positions
7602673208	445/65R22.5	XZY-3	MICHELIN	455	L	20	12,800	45.8	All-position radial designed for exceptional wear and traction in mixed on/off road service

All tires listed are radials.

Availability can change without warning.

*Seals up to ¼" diameter punctures in the repairable area of the tread. Does not seal sidewall punctures.

Feature	Size	Description	Manufacturer	Rev/Mile	Load Range	Ply	Maximum Load Single (lb)	Maximum Load Dual (lb)	Unloaded Diameter (in)	Application
7372130509	11R22.5	D660	GENERAL	492	G	14	6175	5840	42.1	Tandem drive axle to long and short over-the-highway use
7372130524	11R22.5	S581	GENERAL	500	G	14	6175	5840	41.4	Long haul, over-the-highway steering and all-position use
7372135401	11R22.5	HDL ECO PLUS	CONTINENTAL	493	G	14	6175	5840	42.0	Long haul, over the highway, drive position
7372135414	11R22.5	HSL2	CONTINENTAL	500	G	14	6175	5840	41.4	Long haul, over-the-highway steering and all-purpose use
7372135415	11R22.5	HSR2	CONTINENTAL	498	G	14	6175	5840	41.6	Regional hauling and on/off road, all-position
7372135418	11R22.5	HDR1	CONTINENTAL	495	G	14	6175	5840	41.8	Drive position, short and long-haul — on/off highway service (depending on conditions)
7372138101	11R22.5	G305AT LHD FUEL MAX	GOODYEAR	495	G	14	6175	5840	42.2	Long haul/regional — a fuel-efficient tire that provides long mileage
7372138107	11R22.5	G661 HSA1	GOODYEAR	497	G	14	6175	5840	41.8	Enhanced toughness for high-scrub applications
7372138108	11R22.5	G662 FUEL MAX	GOODYEAR	497	G	14	6175	5840	41.8	Long tread life and toughness for regional highway and local driving
7372138116	11R22.5	G399 LHS FUEL MAX	GOODYEAR	504	G	14	6175	5840	41.2	Long haul/regional steer fuel efficiency combined with long mileage
7372138118	11R22.5	G572 LHD FUEL MAX	GOODYEAR	492	G	14	6175	5840	42.4	A fuel-efficient long haul drive tire with long mileage
7402133217	11R22.5	XDE M/S	MICHELIN	498	G	14	6175	5840	41.6	The open shoulder drive axle engineered for excellent mileage and traction across a wide range of applications
7472133208	11R22.5	XZY-3	MICHELIN	496	G	14	6175	5840	41.8	All-position radial designed for exceptional wear and traction in mixed on/off road service
7472133264	11R22.5	XDN2	MICHELIN	496	G	14	6175	5840	41.7	All-weather, non-directional, premium drive tire optimized for exceptional traction with no compromise on tread wear
7472133269	11R22.5	XZE2	MICHELIN	501	G	14	6175	5840	41.3	Regional, all-position radial with extra-wide, extra-deep tread designed to help deliver best wear in high scrub applications
7472133274	11R22.5	XDA5	MICHELIN	497	G	14	6175	5840	41.7	Long wearing long haul drive tire featuring regenerating tread features that deliver excellent traction late in life
7382130121	11R22.5	G182 RSD	GOODYEAR	496	H	16	6610	6005	42.1	All-around tire for regional service
7382130125	11R22.5	G287 MSA	GOODYEAR	498	H	16	6610	6005	41.7	Superior over-the-road performance
7382130126	11R22.5	G288 MSA	GOODYEAR	498	H	16	6610	6005	41.9	Outstanding performance in off-highway rough road conditions
7382130162	11R22.5	UNISTEEL G177	GOODYEAR	493	H	16	6610	6005	42.3	Seals tread punctures* and is for rugged off-road conditions like coal fields
7382135401	11R22.5	HDL ECO PLUS	CONTINENTAL	493	H	16	6610	6005	42.0	Long haul, over the highway, drive position

All tires listed are radials.

Availability can change without warning.

*Seals up to ¼" diameter punctures in the repairable area of the tread. Does not seal sidewall punctures.

Appendix I

● Rear Tire Specifications

On-Highway Trucks

Feature	Size	Description	Manufacturer	Rev/Mile	Load Range	Ply	Maximum Load Single (lb)	Maximum Load Dual (lb)	Unloaded Diameter (in)	Application
7382135413	11R22.5	HDO	CONTINENTAL	490	H	16	6610	6005	42.4	Logging, mining, construction and other aggressive, off-road traction needs
7382135417	11R22.5	HDL2 DL	CONTINENTAL	491	H	16	6610	6005	42.4	Long haul, over the highway, drive position
7382135418	11R22.5	HDR1	CONTINENTAL	495	H	16	6610	6005	41.8	Drive position, short and long-haul — on/off highway service (depending on conditions)
7382135419	11R22.5	HSC1	CONTINENTAL	496	H	16	6610	6005	41.7	Coal haulers, logging, construction, waste haulers and other all-position service
7382135420	11R22.5	HDC1	CONTINENTAL	488	H	16	6610	6005	42.4	Coal haulers, logging, construction, waste haulers, school buses and other on/off highway service
7382138103	11R22.5	G287 MSA DURASEAL	GOODYEAR	498	H	16	6610	6005	41.7	Puncture-sealing* superior over-the-road performance
7452133217	11R22.5	XDE M/S	MICHELIN	497	H	16	6610	5950	41.7	The open shoulder drive axle engineered for excellent mileage and traction across a wide range of applications
7452133276	11R22.5	XDS2	MICHELIN	494	H	16	6610	6005	41.9	Drive axle radial for year round traction, optimized for winter conditions and limited all position service
7482133208	11R22.5	XZY-3	MICHELIN	496	H	16	6610	6005	41.8	All-position radial designed for exceptional wear and traction in mixed on/off road service
7482133213	11R22.5	XDE2+	MICHELIN	497	H	16	6940	6395	41.7	Open shoulder drive axle radial designed for regional/highway service (directional tread)
7482133264	11R22.5	XDN2	MICHELIN	496	H	16	6610	6005	41.6	All-weather, non-directional, premium drive tire optimized for exceptional traction with no compromise on tread wear
7482133269	11R22.5	XZE2	MICHELIN	501	H	16	6610	6005	41.4	Regional, all-position radial with extra-wide, extra-deep tread designed to help deliver best wear in high scrub applications
7374228116	11R24.5	G399 LHS FUEL MAX	GOODYEAR	481	G	14	6610	6005	43.2	Long haul/regional steer fuel efficiency combined with long mileage
7474223217	11R24.5	XDE M/S	MICHELIN	475	G	14	6610	6005	43.8	The open shoulder drive axle engineered for excellent mileage and traction across a wide range of applications
7474223262	11R24.5	XDA3	MICHELIN	473	G	14	6610	6005	43.8	Fuel-efficient, standard drive tire that helps deliver long, even tread wear and a smooth quiet ride
7474223268	11R24.5	XZA3+	MICHELIN	479	G	14	6610	6005	43.3	Ultra-fuel-efficient radial that delivers long original tread life in long haul steer service
7474223269	11R24.5	XZE2	MICHELIN	476	G	14	6610	6005	43.5	Regional, all-position radial with extra-wide, extra-deep tread designed to help deliver best wear in high scrub applications
7474223274	11R24.5	XDA5	MICHELIN	472	G	14	6610	6005	43.8	Long wearing long haul drive tire featuring regenerating tread features that deliver excellent traction late in life

All tires listed are radials.

Availability can change without warning.

*Seals up to ¼" diameter punctures in the repairable area of the tread. Does not seal sidewall punctures.

Feature	Size	Description	Manufacturer	Rev/Mile	Load Range	Ply	Maximum Load Single (lb)	Maximum Load Dual (lb)	Unloaded Diameter (in)	Application
7384220121	11R24.5	G182 RSD	GOODYEAR	473	H	16	7160	6610	44.1	All-around tire for regional service
7384220125	11R24.5	G287 MSA	GOODYEAR	475	H	16	7160	6610	43.7	Superior over-the-road performance
7384220162	11R24.5	UNISTEEL G177	GOODYEAR	471	H	16	7160	6610	44.3	Seals tread punctures* and is for rugged off-road conditions like coal fields
7384225415	11R24.5	HSR2	CONTINENTAL	476	H	16	7160	6610	43.5	Regional hauling and on/off road, all-position
7384228105	11R24.5	G282 MSD	GOODYEAR	475	H	16	7160	6610	43.9	Long on-/off-highway performance
7384228108	11R24.5	G662 FUEL MAX	GOODYEAR	497	H	16	6610	6005	41.8	Long tread life and toughness for regional highway and local driving
7484223217	11R24.5	XDE M/S	MICHELIN	474	H	16	7160	6610	43.9	The open shoulder drive axle engineered for excellent mileage and traction across a wide range of applications
7484223274	11R24.5	XDA5	MICHELIN	471	H	16	7160	6610	43.8	Long wearing long haul drive tire featuring regenerating tread features that deliver excellent traction late in life
6354060162	1200R24**	UNISTEEL G177	GOODYEAR	423	J	18	9370	8450	49.4	Seals tread punctures* and is for rugged off-road conditions like coal fields
6394060126	1200R24**	G288 MSA	GOODYEAR	430	J	18	9370	8540	45.0	Outstanding performance in off-highway rough road conditions
7382150125	12R22.5	G287 MSA	GOODYEAR	482	H	16	7390	6780	43.1	Superior over-the-road performance
7382150162	12R22.5	UNISTEEL G177	GOODYEAR	478	H	16	7390	6780	43.7	Seals tread punctures* and is for rugged off-road conditions like coal fields
7382155419	12R22.5	HSC1	CONTINENTAL	482	H	16	7390	6780	43.0	Coal haulers, logging, construction, waste haulers, and other all-position service
7382158102	12R22.5	G622 RSD	GOODYEAR	482	H	16	7390	6780	43.3	For regional and local high-scrub applications
7382158103	12R22.5	G287 MSA DURASEAL	GOODYEAR	482	H	16	7390	6780	43.1	Puncture-sealing* superior over-the-road performance
7382158105	12R22.5	G282 MSD	GOODYEAR	481	H	16	6610	6005	41.9	Long on-/off-highway performance
7382158107	12R22.5	G661 HSA1	GOODYEAR	484	H	16	7390	6780	42.9	Enhanced toughness for high-scrub applications
7422153253	12R22.5	XZE	MICHELIN	486	H	16	7390	6750	42.6	All-position radial with extra-wide, extra-deep tread designed to help deliver best wear in high scrub applications
7482153208	12R22.5	XZY-3	MICHELIN	483	H	16	7390	6780	42.9	All-position radial designed for exceptional wear and traction in mixed on/off road service
7384240125	12R24.5	G287 MSA	GOODYEAR	463	H	16	7830	7160	44.9	Superior over-the-road performance
7384240162	12R24.5	UNISTEEL G177	GOODYEAR	457	H	16	7830	7160	45.7	Seals tread punctures** and is for rugged off-road conditions like coal fields
7484243208	12R24.5	XZY-3	MICHELIN	461	H	16	7830	7160	44.9	All-position radial designed for exceptional wear and traction in mixed on/off road service
7702490524	295/75R22.5	S581	GENERAL	516	G	14	6175	5675	40.1	Long haul, over-the-highway steering and all-position use

All tires listed are radials.

Availability can change without warning.

*Seals up to ¼" diameter punctures in the repairable area of the tread. Does not seal sidewall punctures.

**Tubed tires.

Appendix I ● Rear Tire Specifications

On-Highway Trucks

Feature	Size	Description	Manufacturer	Rev/Mile	Load Range	Ply	Maximum Load Single (lb)	Maximum Load Dual (lb)	Unloaded Diameter (in)	Application
7702540190	315/80R22.5	UNISTEEL G291	GOODYEAR	491	J	18	8270	7610	42.3	All-position tire with wear and traction toughness for rugged metro service
7652543208	315/80R22.5	XZY-3	MICHELIN	486	L	20	9090	8270	42.9	All-position radial designed for exceptional wear and traction in mixed on/off road service
7682543212	315/80R22.5	XZU-S2	MICHELIN	488	L	20	10,000	8270	42.8	All-position tire with high carrying capacity designed for exceptional tread life in high scrub urban applications such as refuse vehicles
7772540125	315/80R22.5	G287 MSA	GOODYEAR	485	L	20	9090	8270	42.8	Superior over-the-road performance
7772540190	315/80R22.5	UNISTEEL G291	GOODYEAR	491	L	20	9090	8270	42.3	All-position tire with wear and traction toughness for rugged metro service
7782548109	315/80R22.5	G289 WHA	GOODYEAR	484	L	20	10,200	9090	43.1	Offers a 68 MPH speed rating and helps provide outstanding performance in waste haul applications
7792545416	315/80R22.5	HSU2+	CONTINENTAL	481	L	20	10,000	9090	43.0	Waste haulers, construction and other on/off highway service
7602653208	385/65R22.5	XZY-3	MICHELIN	491	J	18	9370	—	42.4	All-position radial designed for exceptional wear and traction in mixed on/off road service
7702658113	385/65R22.5	G296 MSA	GOODYEAR	488	J	18	9370	—	42.5	Long mileage super single tire for heavy on- and off-road applications
7792655412	385/65R22.5	HTC1	CONTINENTAL	493	L	20	9920	—	42.0	Super single fitment for steer and trailer positions
7652663208	425/65R22.5	XZY-3	MICHELIN	465	L	20	11,400	—	44.7	All-position radial designed for exceptional wear and traction in mixed on/off road service
7652663267	425/65R22.5	XZL	MICHELIN	467	L	20	11,400	—	44.8	All-terrain, all-position radial for special service such as emergency response vehicles
7752665412	425/65R22.5	HTC1	CONTINENTAL	465	L	20	11,400	—	44.5	Super single fitment for steer and trailer positions
7752668113	425/65R22.5	G296 MSA	GOODYEAR	468	L	20	11,400	—	44.4	Long mileage super single tire for heavy on- and off-road applications
7602673208	445/65R22.5	XZY-3	MICHELIN	455	L	20	12,800	—	45.8	All-position radial designed for exceptional wear and traction in mixed on/off road service
7702678113	445/65R22.5	G296 MSA	GOODYEAR	457	L	20	12,300	—	45.5	Long mileage super single tire for heavy on- and off-road applications

All tires listed are radials.
Availability can change without warning.

Front Suspension Specifications

Multi Leaf Shackle

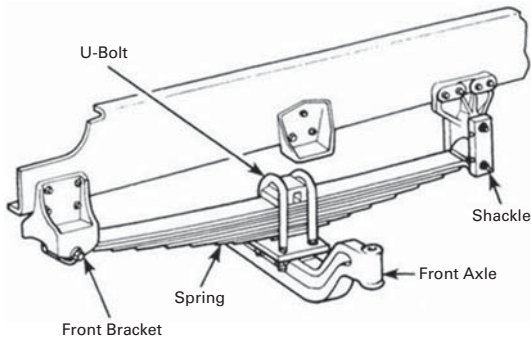

- Improved ride performance.
- Recommended for heavy duty applications (on/off road) 20,000 lb or lower.
- Can be used for heavy duty on-highway applications above 20,000 lb with limited off road.

Parabolic Taper Leaf

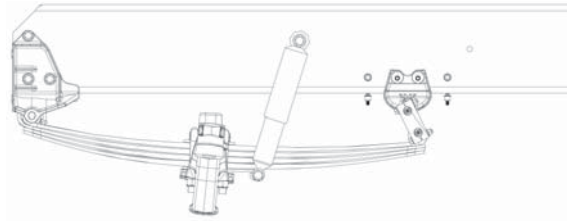

- Best ride.
- Lightest weight.
- Shock absorber required.
- Recommended for heavy duty applications (on/off road) 20,000 lb or lower.

Multi Leaf Slipper

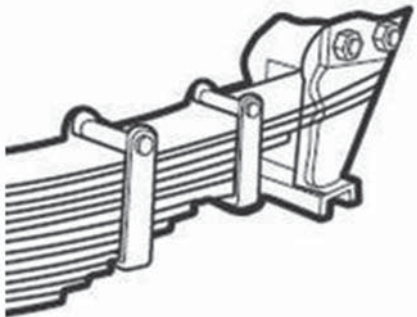

- Most durable.
- Recommended for severe off road applications above 20,000 lb.

Appendix J
● Front Suspension Specifications

On-Highway Trucks

Feature Code	Description	CT681	6x4	114	BBC	CT680	6x4	124	BBC	CT660	6x4	116	BBC	CT660	6x4	122	BBC	CT660	4x4	122	BBC	CT660	6x6	122	BBC	CT660	8x6	124	BBC	CT660	8x6	116	BBC	CT660	8x6	122	BBC	Load Rating (lb)	With Shock	Torque Rods	
0003ADC	SPRING Parabolic, Taper Leaf	x	x																																		12,000	Y			
0003ADS	SPRING Multi Leaf; 12,000-lb Capacity Left; 10,000-lb Capacity Right; Use with Left Wing Snow Plow																										x	x									12,000				
0003AGD	SUSPENSION, FRONT, SPRING Parabolic, Taper Leaf; 13,200-lb Capacity; with Shock Absorbers																																					13,200	Y		
0003ACH	SPRING Multi Leaf, Shackle																																					14,000	Y	N	
0003ADD	SPRING Parabolic, Taper Leaf	x	x																																			14,000	Y		
0003ACP	SPRING Multi Leaf, Shackle																																						16,000	N	N
0003ADE	SPRING Parabolic, Taper Leaf	x	x																																			16,000	Y		
0003ACR	SPRING Multi Leaf, Shackle																																						18,000	N	N
0003ADG	SPRING Parabolic, Taper Leaf	x	x																																				18,000	Y	
0003ADH	SPRING Parabolic, Taper Leaf	x	x																																				18,000	Y	
0003ACS	SPRING Multi Leaf, Shackle																																						20,000	N	N
0003ACU	SPRING Multi Leaf, Slipper																																						20,000	N	Y
0003ADR	SPRING Multi Leaf, Slipper, includes (1) Extra Leaf on Right Side																																						20,000		Y
0003AEB	SPRING Taper Leaf, Shackle; 18,000-lb Capacity Steel Springs with (2) Aeon Rubber Auxiliary Springs (2000-lb Capacity); includes One Extra Leaf and 1.0" Spacer on Left Side	x																																					20,000		
0003AEX	SPRING Two Stage Multi Leaf; Two Stage Steel Springs and (2) Rubber Auxiliary Springs	x	x																																				20,000	Y	N
0003AGA	SPRING Parabolic, Taper Leaf																																						20,000	Y	
0003AGR	SPRING Multi Leaf, Shackle, Two Stage Spring																																						20,000	N	N
0003ACW	SPRING Multi Leaf, Slipper																																						21,000	N	Y
0003ACT	SPRING Multi Leaf, Shackle																																						23,000	N	N
0003AEP	SPRING Multi Leaf, Shackle; with Special Spacer Blocks for Mixer Application																																						23,000	N	N
0003ACX	SPRING Multi Leaf, Slipper																																						24,000	N	Y

Rear Suspension Details

HENDRICKSON Walking Beam Suspension



HAULMAAX/HMX

- Recommended for dump, refuse, mixer, building /material supply and logging applications.
- Lightweight design for additional payload and route consolidation.
- Reduced maintenance with fewer bushings and no lubrication requirements.
- VariRate spring system provides superior combination of empty ride and loaded stability.
- Up to 17 in of diagonal articulation for greater off-road mobility.
- Capacities of 40,000 and 46,000 lb.



RT

- RT Series well suited for dump, refuse and building/material supply.
- Engineered with low maintenance bushings and spring assemblies.
- Operating in the field for over 85 years.
- RT capacities up to 65,000 lb.

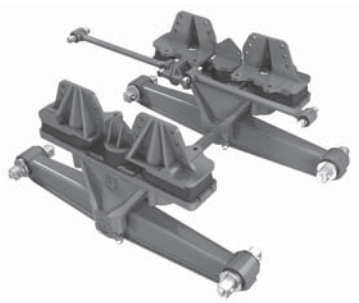

RS/R

- Recommended for mining, refuse, logging and other specialty applications.
- R Series solid mount is an extra heavy-duty suspension where maximum roll stability is essential.
- RS rubber load cushions absorb shock and provide high roll stability for severe-service applications.
- Capacities up to 85,000 lb.

Rear Suspension Details (cont'd)



**Chalmers
Suspensions**

Walking Beam Suspension

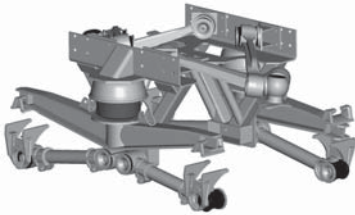

800 Series

- Recommended for all types of applications, mixer, refuse, dump, logging, oilfield, mining, tanker, airport refueler and other vocational applications.
- Lightweight design, minimum maintenance, improved traction on uneven ground because axles do not transfer weight from one axle to the other.
- Loadguard hollow rubber spring is virtually indestructible, variable rate self damping for enhanced ride qualities laden and unladen. Greatly increased stability, combats side sway with wider spring centers.
- Full freedom of articulation both “parallel and diagonal.”
- Capacity range from 40,000 to 52,000 lb.



Air Suspension

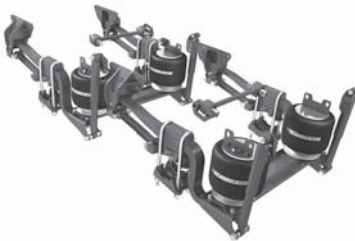

HAS

- Suited for both on- and off-highway applications.
- Excellent ride quality.
- Approved for up to 25 percent off-highway use.
- Approved for use with lift axles.
- Optional inboard shocks available.
- Capacities of 40,000 and 46,000 lb.



PRIMAAX

- Approved for 100% off-highway use.
- Ideal for heavy-haul, dump, logging, refuse, mixer, building/material supply and crane applications.
- Optimized configuration helps improve handling and roll stiffness for expanded applications.
- Axle connection and torque rods help reduce torsional axle stress and drive-line vibration.
- Large-volume, low frequency air springs provide a smooth ride for on- and off-road usage.
- Up to 12.5 in of diagonal wheel articulation for superior mobility.
- Capacities of 46,000 lb and 52,000 lb.

Rear Suspension Details (cont'd)



Air Suspension for Tridem Axles



AD Series

- 100% off-highway rated performance.
- Designed for maximum durability in challenging operational environments.
- Non-torque reactive design maintains proper pinion angle to reduce unwanted driveline vibration and noise while helping increase driveline component life.
- Proprietary SAF-Holland rubber bushings and Sachs shocks are standard for increased durability and service life.

Developed for severe duty applications characterized by:

- Heavy vertical loads
- High gross combined weights
- High torque drive trains
- High center of gravity loads
- Significant off-highway travel

Severe and Heavy Duty Applications Include:

- Heavy haul/heavy construction
- Mine/Pit/Quarry
- Logging
- Oilfield
- Mixers and dumps for aggregate
- Asphalt and concrete transfer
- Straight truck in municipal, utility, and maintenance

Appendix L

● Rear Suspension Specifications

On-Highway Trucks

Feature Code	Description	Rear Suspension							Load Rating (lb)	Air Ride	Walking Beam	Spring	Tandem	Tridem	Axle Spacing (in)
		CT681 6x4 1114 BBC	CT680 6x4 124 BBC	CT660 6x4 116 BBC	CT660 6x4 122 BBC	CT660 4x4 122 BBC	CT660 6x6 122 BBC	CT680 8x6 124 BBC							
0014SAP	SINGLE Constant Rate, Double Eye Type, includes 4500-lb Capacity Auxiliary					x			23,000		x	x			
0014SAD	SINGLE Constant Rate, Double Eye Type, includes 4500-lb Capacity Multi Leaf Auxiliary					x			30,000		x	x			
0014UHD	Hendrickson RT-403 with Rubber Center Bushings	x	x	x	x		x		40,000	x			x		54
0014ULA	Hendrickson HAS-402-60 9.5" Ride Height, with Shock Absorbers Mounted in Standard Location	x	x	x	x				40,000	x			x		60
0014ULU	Hendrickson HAS-402-55 9.5" Ride Height, with Shock Absorbers Mounted Inboard	x	x	x	x				40,000	x			x		55
0014ULV	Hendrickson HAS-402-60 9.5" Ride Height, with Shock Absorbers Mounted Inboard	x	x	x	x				40,000	x			x		60
0014ULX	Hendrickson HMX-400-54 with Rubber End Bushings, Transverse Torque Rods, Less Shock Absorbers	x	x	x	x		x		40,000	x			x		54
0014UZS	Chalmers 854-40L with Standard Restrictor Cans, (8) Torque Rods, Less Shocks	x	x	x	x				40,000	x			x		54
0014UKZ	Hendrickson HAS-402-55, 9.5" Ride Height, with Shock Absorbers Mounted in Standard Location	x	x	x	x				40,000	x			x		55
0014VBA	Hendrickson HAS-402-55, 6.5" Ride Height, with Shock Absorbers Mounted Inboard	x	x	x	x				40,000	x			x		55
0014VBC	Hendrickson HAS-402-60, 6.5" Ride Height, with Shock Absorbers Mounted Inboard	x	x	x	x				40,000	x			x		60
0014UHK	Hendrickson RT-463 with Bronze Center Bushings	x	x	x	x		x		46,000	x			x		54
0014UHL	Hendrickson RT-463 with Transverse Torque Rods and Rubber Center Bushings	x	x	x	x		x		46,000	x			x		60
0014ULB	Hendrickson HAS-460-55 9.5" Ride Height, with Shock Absorbers Mounted in Standard Location	x	x	x	x				46,000	x			x		55
0014ULC	Hendrickson HAS-460-60 9.5" Ride Height, with Shock Absorbers Mounted in Standard Location	x	x	x	x				46,000	x			x		60
0014ULS	Hendrickson HAS-460-60 9.5" Ride Height, with Shock Absorbers Mounted Inboard	x	x	x	x				46,000	x			x		60
0014ULT	Hendrickson HAS-460-55 9.5" Ride Height, with Shock Absorbers Mounted Inboard	x	x	x	x				46,000	x			x		55
0014ULY	Hendrickson HMX-460-54 with Rubber End Bushings, Transverse Torque Rods, Less Shock Absorbers	x	x	x	x		x		46,000	x			x		54
0014ULZ	Hendrickson HMX-460-60 with Rubber End Bushings, Transverse Torque Rods, Less Shock Absorbers	x	x	x	x		x		46,000	x			x		60
0014UMC	Hendrickson HMX-460-72.5 with Rubber End Bushings, Transverse Torque Rods, Less Shock Absorbers	x	x	x	x		x		46,000	x			x		73
0014UNW	Hendrickson PAX-460-72 9.0" Ride Height, with Shock Absorbers Mounted in Standard Location	x	x	x	x				46,000	x			x		72
0014UNY	Hendrickson PAX-460-60 9.0" Ride Height, with Shock Absorbers Mounted in Standard Location	x	x	x	x				46,000	x			x		60
0014UZB	Chalmers 854-46H-HS with High Stability (HS) Restrictor Cans and (8) Torque Rods Less Shocks	x	x	x	x				46,000	x			x		54
0014UZT	Chalmers 860-46H-HS with High Stability (HS) Restrictor Cans, (8) Torque Rods, Less Shocks	x	x	x	x				46,000	x			x		60
0014UZU	Chalmers 854-46H with Standard Restrictor Cans, (8) Torque Rods, Less Shocks	x	x	x	x				46,000	x			x		54
0014UZV	Chalmers 860-46H with Standard Restrictor Cans, (8) Torque Rods, Less Shocks	x	x	x	x				46,000				x		60
0014UZW	Chalmers 872-46H-HS with High Stability Restrictor Cans, (8) Torque Rods, Less Shocks	x	x	x	x				46,000	x			x		72
0014VBE	Hendrickson HAS-460-55, 6.5" Ride Height, with Shock Absorbers Mounted Inboard	x	x	x	x				46,000	x			x		55
0014VBH	Hendrickson HAS-460-60, 6.5" Ride Height, with Shock Absorbers Mounted Inboard	x	x	x	x				46,000	x			x		60
0014698	Hendrickson RT-523 with Bronze Center Bushings	x	x	x	x		x		52,000	x			x		54
0014UZX	Chalmers 854-52-H-HS with High Stability Restrictor Cans, (8) Torque Rods, Less Shocks	x	x	x	x				52,000	x			x		54
0014UNX	Hendrickson PAX-460-55, 9.0" Ride Height, with Shock Absorbers Mounted in Standard Location	x	x	x	x				52,000	x			x		55
0014UPU	Hendrickson PAX-520-60, 10.0" Ride Height, with Shock Absorbers Mounted in Standard Location	x	x	x	x				52,000	x			x		60
0014UPV	Hendrickson PAX-520-55, 9.0" Ride Height, with Shock Absorbers Mounted in Standard Location	x	x	x	x				52,000	x			x		55
0014UPW	Hendrickson PAX-520-60, 9.0" Ride Height, with Shock Absorbers Mounted in Standard Location	x	x	x	x				52,000	x			x		60
0014UPX	Hendrickson PAX-520-55, 10.0" Ride Height, with Shock Absorbers Mounted in Standard Location	x	x	x	x				52,000	x			x		55
0014524	Hendrickson RT-650 with Rubber Center Bushings	x	x	x	x		x		65,000	x			x		56
0014VKD	Neway AD-369 10.00" Ride Height, with Shock Absorbers							x	69,000	x				x	55
0014VKE	Neway AD-378 10.00" Ride Height, with Shock Absorbers							x	78,000	x				x	55
0014UJE	Hendrickson R-700, Solid Mount Less Transverse Torque Rods	x	x	x	x				80,000	x			x		60
0014UNR	Hendrickson RS-850 Less Transverse Torque Rods and with Rubber Load Cushions, with 9.75" Ride Height and 35.875" Frame Width	x	x	x	x		x		85,000	x			x		60

Power Take Off Specifications
Rear Engine PTO for CT13 Engines

Engine RPM	REPTO RPM	REPTO Torque (lbf-ft)	REPTO HP
800	1021	479	92
900	1148	479	105
1000	1276	479	117
1100	1404	479	128
1200	1531	479	140
1300	1659	479	151
1400	1786	479	163
1500	1914	479	175
1600	2042	479	186
1700	2169	479	198

NOTE: 6 bolt circle, CCW rotation.

Front Engine PTO (CT681)

Engine RPM	FEPTO RPM	FEPTO Torque (lbf-ft)	FEPTO HP
800	800	479	73
900	900	479	82
1000	1000	479	91
1100	1100	479	100
1200	1200	479	109
1300	1300	479	119
1400	1400	479	128
1500	1500	479	137
1600	1600	479	146
1700	1700	479	155

NOTE: 4 bolt circle, CW rotation.

CX31 Automatic Transmission Power Take Off Ports

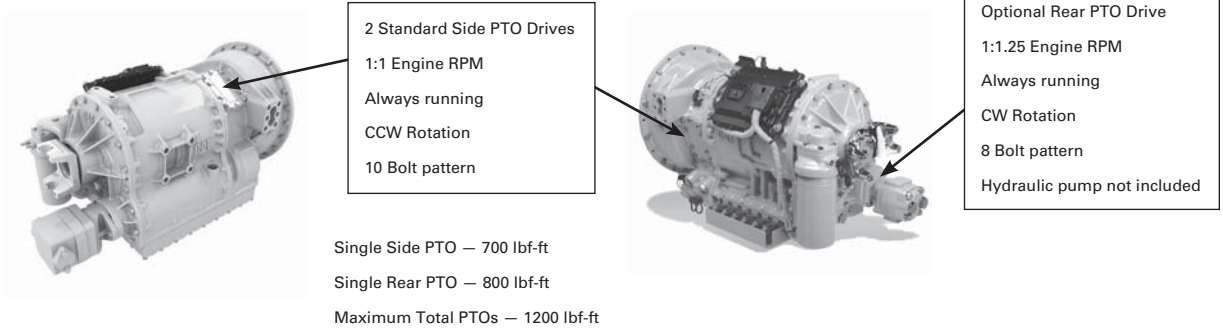

Side PTOs

Engine RPM	PTO RPM	Torque (lbf-ft)	HP
800	800	700	107
900	900	700	120
1000	1000	700	133
1100	1100	700	147
1200	1200	700	160
1300	1300	700	173
1400	1400	700	187
1500	1500	700	200
1600	1600	700	213
1700	1700	700	227
1800	1800	700	240
1900	1900	700	253
2000	2000	700	267
2100	2100	700	280

Optional Rear Thru-Shaft PTOs

Engine RPM	PTO RPM	Torque (lbf-ft)	HP
800	1000	800	152
900	1125	800	171
1000	1250	800	190
1100	1375	800	209
1200	1500	800	228
1300	1625	800	248
1400	1750	800	267
1500	1875	800	286
1600	2000	800	305
1700	2125	800	324
1800	2250	800	343
1900	2375	800	362
2000	2500	800	381
2100	2625	800	400

PAVING PRODUCTS

CONTENTS

COLD PLANERS

Sustainability	13-1
Features	13-1
Specifications	13-2
Production Estimating	13-3
Machine Selection	13-5
Cold Planing Fundamentals	13-5
Applications	13-7
Cold Planer Use by Project Type	13-8

ROTARY MIXERS

Sustainability	13-9
Features	13-9
Specifications	13-10
Optional Equipment	13-11
Production Estimating	13-11
Weight of Materials	13-12
Stabilization/Reclamation Production	13-12

ASPHALT PAVERS

Sustainability	13-13
Features	13-13
Specifications	13-14
Screeds	13-18
Production Table	13-20
Slope Conversion Table/ Inches in Decimals Table	13-21

VIBRATORY AND PNEUMATIC TIRE COMPACTORS

Sustainability	13-22
Features	13-22
Specifications: Vibratory Compactors	13-23
Pneumatic Tire Compactors	13-37
Pneumatic Tires: Inflation Pressures	13-38
Ballast Configurations	13-38
Maximum Ground Pressures	13-39
Ground Contact Pressure — CW34	13-39
Production Estimating: Vibratory Compactors	13-40
Pneumatic Tire Compactors	13-44

Cold Planer

Sustainability:

- **Long-lasting lubricants and fluids** extend maintenance intervals, decreasing the amount of waste and filters contributed to environment.
- **Superior Cat® cutting tools last longer**, providing higher daily productivity with less fuel burn.
- **Available Cat Diamond Cutting Bits** last up to 80 times longer than conventional carbide bits.
- **Ecology drains** provide a simple means to drain machine fluids with a minimized risk of spillage.
- **Maintenance free Cat batteries** are recyclable.
- **Cat ACERT™ engines** meet applicable emission standards.
- **Cold planers recycle aggregate from worn out roads** for use in new roads, reducing the cost and energy needs required for excavating, processing and hauling virgin aggregate.

Features:

- **Cat ACERT engines.**
- **Up-cutting mandrels** provide cutting efficiency and improved bit life.
- **Short turning radii** for productivity and job site flexibility.
- **Front-discharge conveyor** facilitates haul unit movement in congested urban applications.
- **Optimum weight-to-horsepower balance** for delivering maximum available horsepower to the cutter.
- **Computerized Monitoring System (CMS)** provides three warning levels for abnormal operating conditions.
- **Load control system** keeps machine operating at peak efficiency.
- **Water spray system** for dust control and bit cooling.
- **Optional Cat Grade and Slope** available for PM200 models.

MODEL	PM102		PM200 — 2.0 m		PM200 — 2.2 m	
Gross Power	168 kW	225 hp	429 kW	575 hp	429 kW	575 hp
Operating Weight	17 600 kg	38,810 lb	30 100 kg	66,359 lb	31 500 kg	69,445 lb
Engine Model	C7 ACERT		C18 ACERT		C18 ACERT	
Emission Standards	U.S. EPA Tier 3/ EU Stage IIIA equivalent		Tier 3/ Stage IIIA equivalent		Tier 3/ Stage IIIA equivalent	
Rated Engine RPM	2200		1900		1900	
No. of Cylinders	6		6		6	
Bore	110 mm	4.3"	145 mm	5.7"	145 mm	5.7"
Stroke	127 mm	5.0"	183 mm	7.2"	183 mm	7.2"
Displacement	7.2 L	442 in³	18.1 L	1105 in³	18.1 L	1105 in³
Drive Systems: Rotor	Mechanical		Mechanical		Mechanical	
Ground	Hydrostatic with 4 track design		Hydrostatic with 4 track design		Hydrostatic with 4 track design	
Discharge Conveyor Width	600 mm	23.6"	800 mm	31.5"	800 mm	31.5"
Width of Standard Track Shoe	225 mm	8.8"	300 mm	12"	300 mm	12"
Track Length on Ground	720 mm	28.3"	1640 mm	64.5"	1640 mm	64.5"
Operating Dimensions:						
Height	3400 mm	11'2"	3950 mm	12'7"	3950 mm	12'7"
Width	2500 mm	8'2"	2750 mm	9'0"	2970 mm	9'9"
Length	10 700 mm	35'1"	13 940 mm	45'7"	13 940 mm	45'7"
Standard Mandrel (Width of Cut)	1000 mm	40"	2010 mm	79"	2235 mm	88"
No. of Teeth	97		178		193	
Depth of Cut (Max.)	305 mm	12"	320 mm	12.6"	320 mm	12.6"
Speeds: Operating (Max.)						
Track undercarriage	27 m/min	89 ft/min	38 m/min	125 ft/min	38 m/min	125 ft/min
Wheel undercarriage	46 m/min	151 ft/min	—		—	
Speeds: Travel (Max.)						
Track undercarriage	4.1 km/h	2.5 mph	5.9 km/h	3.6 mph	5.9 km/h	3.6 mph
Wheel undercarriage	6.4 km/h	3.9 mph	—		—	
Inside Turning Radius: Right						
Track undercarriage	3450 mm	11'3"	2000 mm	6'5"	2000 mm	6'5"
Wheel undercarriage	2100 mm	6'8"	—		—	
Fuel Capacity	400 L	105 U.S. gal	1100 L	290 U.S. gal	1100 L	290 U.S. gal
Water Capacity	1060 L	280 U.S. gal	3500 L	925 U.S. gal	3500 L	925 U.S. gal

		Cutter/Drum Width — m ² /min (yd ² /min)									
Speed		350 mm (1'2")		400 mm (1'4")		500 mm (1'8")		600 mm (2'0")		1000 mm (3'4")	
m/min	ft/min	m ²	yd ²	m ²	yd ²	m ²	yd ²	m ²	yd ²	m ²	yd ²
3.0	10	1.1	1.3	1.2	1.4	1.5	1.8	1.8	2.2	3.0	3.6
4.6	15	1.6	1.9	1.8	2.2	2.3	2.8	2.8	3.3	4.6	5.5
6.1	20	2.1	2.6	2.4	2.9	3.1	3.6	3.7	4.4	6.1	7.3
7.6	25	2.7	3.2	3.0	3.6	3.8	4.5	4.6	5.5	7.6	9.1
9.1	30	3.2	3.8	3.6	4.4	4.6	5.4	5.5	6.5	9.1	10.9
10.7	35	3.7	4.5	4.3	5.1	5.4	6.4	6.4	7.7	10.7	12.8
12.2	40	4.3	5.1	4.9	5.8	6.1	7.3	7.3	8.8	12.2	14.6
13.7	45	4.8	5.7	5.5	6.6	6.9	8.2	8.2	9.8	13.7	16.4
15.2	50	5.3	6.4	6.1	7.3	7.6	9.1	9.1	10.9	15.2	18.2
16.8	55	5.9	7.0	6.7	8.0	8.4	10.0	10.1	12.1	16.8	20.1
18.3	60	6.4	7.7	7.3	8.8	9.2	10.9	11.0	13.1	18.3	21.9
Speed		1220 mm (4'0")		1900 mm (6'3")		2010 mm (6'7")		2100 mm (6'11")		2210 mm (7'3")	
m/min	ft/min	m ²	yd ²	m ²	yd ²	m ²	yd ²	m ²	yd ²	m ²	yd ²
3.0	10	3.7	4.4	5.7	6.8	6.0	7.2	6.3	7.5	6.6	7.9
4.6	15	5.6	6.7	8.7	10.5	9.2	11.1	9.7	11.6	10.2	12.2
6.1	20	7.4	8.9	11.6	13.9	12.3	14.7	12.8	15.3	13.5	16.1
7.6	25	9.3	11.1	14.4	17.3	15.3	18.3	16.0	19.1	16.8	20.1
9.1	30	11.1	13.3	17.3	20.7	18.3	21.9	19.1	22.9	20.1	24.1
10.7	35	13.1	15.6	20.3	24.3	21.5	25.7	22.5	26.9	23.6	28.3
12.2	40	14.9	17.8	23.2	27.7	24.5	29.3	25.6	30.6	27.0	32.2
13.7	45	16.7	20.0	26.0	31.1	27.5	32.9	28.8	34.4	30.3	36.2
15.2	50	18.5	22.2	28.9	34.5	30.6	36.5	31.9	38.2	33.6	40.2
16.8	55	20.5	24.5	31.9	38.2	33.8	40.4	35.3	42.2	37.1	44.4
18.3	60	22.3	26.7	34.8	41.6	36.8	44.0	38.4	46.0	40.4	48.4
Speed		3050 mm (10'0")		3500 mm (11'6")		3810 mm (12'6")					
m/min	ft/min	m ²	yd ²	m ²	yd ²	m ²	yd ²				
3.0	10	9.2	10.9	10.5	12.6	11.4	13.7				
4.6	15	14.0	16.8	16.1	19.3	17.5	21.0				
6.1	20	18.6	22.3	21.4	25.5	23.2	27.8				
7.6	25	23.2	27.7	26.6	31.8	29.0	34.6				
9.1	30	27.8	33.2	31.9	38.1	34.7	41.5				
10.7	35	32.6	39.0	37.5	44.8	40.8	48.8				
12.2	40	37.2	44.5	42.7	51.1	46.5	55.6				
13.7	45	41.8	50.0	48.0	57.3	52.2	62.4				
15.2	50	46.4	55.4	53.2	63.6	57.9	69.3				
16.8	55	51.2	61.3	58.8	70.3	64.0	76.6				
18.3	60	55.8	66.8	64.1	76.6	69.7	83.4				

NOTE: Above figures are based on approximately 25 mm (1 in) depth of cut. For greater depths of cut, multiply the production rate by cutting depth. Figures are based on asphalt density of 2322 kg/m³ (145 lb/ft³). (As referenced on *AsphaltPavement.org* — the website of NAPA.)

Speed		Cutter/Drum Width — metric tons/min (U.S. tons/min)									
		350 mm (1'2")		400 mm (1'4")		500 mm (1'8")		600 mm (2'0")		1000 mm (3'4")	
m/min	ft/min	Metric tons	U.S. tons	Metric tons	U.S. tons	Metric tons	U.S. tons	Metric tons	U.S. tons	Metric tons	U.S. tons
3.0	10	0.06	0.07	0.07	0.08	0.09	0.10	0.10	0.12	0.17	0.19
4.6	15	0.09	0.10	0.11	0.12	0.13	0.15	0.16	0.18	0.27	0.29
6.1	20	0.12	0.14	0.14	0.16	0.18	0.20	0.21	0.23	0.35	0.39
7.6	25	0.15	0.17	0.18	0.19	0.22	0.24	0.26	0.29	0.44	0.49
9.1	30	0.18	0.20	0.21	0.23	0.26	0.29	0.32	0.35	0.53	0.58
10.7	35	0.22	0.24	0.25	0.27	0.31	0.34	0.37	0.41	0.62	0.68
12.2	40	0.25	0.27	0.28	0.31	0.35	0.39	0.42	0.47	0.71	0.78
13.7	45	0.28	0.31	0.32	0.35	0.40	0.44	0.48	0.53	0.80	0.88
15.2	50	0.31	0.34	0.35	0.39	0.44	0.49	0.53	0.58	0.88	0.97
16.8	55	0.34	0.38	0.39	0.43	0.49	0.54	0.59	0.64	0.98	1.07
18.3	60	0.37	0.41	0.42	0.47	0.53	0.59	0.64	0.70	1.06	1.17
Speed		1220 mm (4'0")		1900 mm (6'3")		2010 mm (6'7")		2100 mm (6'11")		2210 mm (7'3")	
		Metric tons	U.S. tons	Metric tons	U.S. tons	Metric tons	U.S. tons	Metric tons	U.S. tons	Metric tons	U.S. tons
3.0	10	0.21	0.23	0.33	0.36	0.35	0.39	0.37	0.40	0.38	0.42
4.6	15	0.33	0.36	0.51	0.56	0.54	0.59	0.56	0.62	0.59	0.65
6.1	20	0.43	0.48	0.67	0.74	0.71	0.78	0.74	0.82	0.78	0.86
7.6	25	0.54	0.59	0.84	0.92	0.89	0.98	0.93	1.02	0.98	1.07
9.1	30	0.64	0.71	1.00	1.11	1.06	1.17	1.11	1.22	1.17	1.29
10.7	35	0.76	0.84	1.18	1.30	1.25	1.38	1.30	1.44	1.37	1.51
12.2	40	0.86	0.95	1.35	1.48	1.42	1.57	1.49	1.64	1.57	1.72
13.7	45	0.97	1.07	1.51	1.67	1.60	1.76	1.67	1.84	1.76	1.94
15.2	50	1.08	1.19	1.68	1.85	1.77	1.95	1.85	2.04	1.95	2.15
16.8	55	1.19	1.31	1.85	2.04	1.96	2.16	2.05	2.26	2.16	2.38
18.3	60	1.30	1.43	2.02	2.22	2.14	2.35	2.23	2.46	2.35	2.59
Speed		3050 mm (10'0")		3500 mm (11'6")		3810 mm (12'6")					
		Metric tons	U.S. tons	Metric tons	U.S. tons	Metric tons	U.S. tons				
3.0	10	0.53	0.59	0.61	0.67	0.66	0.73				
4.6	15	0.81	0.90	0.93	1.03	1.02	1.12				
6.1	20	1.08	1.19	1.24	1.37	1.35	1.49				
7.6	25	1.35	1.48	1.54	1.70	1.68	1.85				
9.1	30	1.61	1.78	1.85	2.04	2.01	2.22				
10.7	35	1.89	2.09	2.17	2.40	2.37	2.61				
12.2	40	2.16	2.38	2.48	2.73	2.70	2.97				
13.7	45	2.43	2.67	2.78	3.07	3.03	3.34				
15.2	50	2.69	2.97	3.09	3.40	3.36	3.70				
16.8	55	2.97	3.28	3.41	3.76	3.72	4.09				
18.3	60	3.24	3.57	3.72	4.10	4.05	4.46				

NOTE: Above figures are based on approximately 25 mm (1 in) depth of cut. For greater depths of cut, multiply the production rate by cutting depth. Figures are based on asphalt density of 2322 kg/m³ (145 lb/ft³). (As referenced on *AsphaltPavement.org* — the website of NAPA.)

MACHINE SELECTION

Prime considerations in selecting the proper cold planer model are:

- specifics of work to be done
- type of projects generally done by the contractor
 - City/Urban or Highway/Airport
- desired production capacities

PM102 Cold Planer

The Cat PM102 Cold Planer features compact dimensions and excellent maneuverability ideal for easy operation in urban applications. The machine performs controlled, full-depth removal of asphalt layers in a single pass and is also capable of concrete removal. The machine is available with a wheel or track undercarriage and features four steering modes for high maneuverability.

PM200 Cold Planer

The Cat PM200 Cold Planer is a high-production, half-lane milling machine with excellent maneuverability and plenty of power to perform controlled full-depth removal of asphalt and concrete pavements in a single pass. The track-driven machine features four steering modes for high maneuverability. The PM200 is available in two configurations. The first configuration features a 2.0 m (79") cutting width and performs well in urban environments or in applications where great maneuverability is required. The second configuration features a 2.2 m (88") cutting width and is ideal for high-production applications such as main line milling.

Cold Planer Characteristics (Highway/Airport)

Highway/Airport work requires high-volume cold planers. The PM200 and other high horsepower half-lane cold planers are being used more on Highway/Airport projects. Users like to have one machine that can work successfully on high production jobs then switch to city/urban applications. The PM200 has proven to be a true cross-over cold planer.

Cold Planer Characteristics (City/Urban)

All Cat cold planers are four-track, front discharge models. Front discharge cold planers make traffic control easier in congested quarters. The trucks travel forward in the same direction as the cold planer. The trucks move in and out of traffic faster increasing production.

COLD PLANING FUNDAMENTALS

Definition

Cold planing is automatically controlled cold milling to restore the pavement surface to a specified grade and slope; remove bumps, ruts, and other imperfections; and leave a textured surface which can be opened immediately to traffic or overlaid with new pavement materials.

Production and Tooth Wear

Because pavement materials vary, so do production and tooth wear. While predicting the exact production rate and tooth wear on a particular job is difficult, general guidelines are available.

Production depends on the milling rate (the speed at which the cold planer moves forward). The machine's forward speed is determined, primarily, by aggregate type, asphalt bond strength and depth of cut. When milling asphalt pavement, the cold planer's teeth essentially are breaking the bond between asphalt-coated aggregate, not actually fracturing the aggregate itself. A pavement made with a mix containing a high percentage of fine aggregate and a high asphalt content is more difficult to mill than a pavement with a high percentage of coarse aggregate.

A dense or fine mix usually requires more power at the cutting drum, limiting the cold planer's forward speed. Decreased speed lowers production, and the tough bond between the small aggregate particles causes increased cutting-tooth wear. Lower production and higher tooth wear result in increased unit costs.

Cutting depth affects power demand at the drum and helps determine the cold planer's forward speed. However, production increases, to a point, as the depth of cut increases. For example, changing from a 25 mm (1 in) cut to a 51 mm (2 in) cut slows the machine only slightly but doubles the amount of material produced.

As the cut increases beyond the machine's peak-production depth, the reduced forward speed begins to offset the production gains of the deeper cut. For example, production at a 152 mm (6 in) cutting depth and slow speed may be no greater than cutting at a 76 mm (3 in) depth and a much faster speed.

Low Density Asphalt

Depth		PM200	
mm	in	m/min	ft/min
51	2	40	130
101	4	32	105
127	5	21	70
178	7	12	40
254	10	6	20
305	12	5	15

High Density Asphalt

Depth		PM200	
mm	in	m/min	ft/min
51	2	32	105
101	4	26	85
127	5	18	60
178	7	9	30
254	10	5	15
305	12	4	12

As long as the cold planer maintains a productive forward speed, deeper cuts will yield greater production and tend to lower tooth cost. Tooth wear does not increase in direct proportion to production when the machine is working in an efficient range.

Tooth wear at various depths for a given material is affected by how long the tooth remains in the cut. Because the teeth are mounted on a circular drum, each tooth cuts through the pavement in an arc. The tooth arc at a 102 mm (4 in) cutting depth, however, is not four times longer than at a 25 mm (1 in) cutting depth, even though production may be four times greater. The cutting arc at 102 mm (4 in) is approximately twice as long as that at 25 mm (1 in).

The peak cutting depth for a particular cold planer on a specific job is best determined by examining production, and subsequent costs, of a single deep cut versus multiple passes at a shallow depth.

APPLICATIONS

Although new applications for cold planers are being discovered, most work can be classified in six general categories:

Leveling and Bonding

This application removes a layer of pavement to eliminate potholes, ruts, bumps and other surface imperfections. The cold planer leaves a level, textured surface ideal for bonding to a new, thin overlay of asphalt or concrete. The surface has an interlocking texture with double the bonding area of a conventional smooth pavement. The textured surface and overlay form a monolithic bond, eliminating the shear plane that causes pavement layers to move and separate. Thinner overlays can be used, making the technique more economical than traditional overlay methods.

Surface Refinishing

Rough pavement can also be cold planed to specified grade and slope, providing a new riding surface without adding new paving materials. This application is particularly useful when base and sub-base are in good shape, or when several layers have been added to the roadway over the years. Roads can be cold planed during cold, wet months and reopened immediately. New overlays can be added whenever weather permits. This lengthens the practical working season for many contractors. The cold planer can also be used to correct expansion joint faults and pavement cracks.

Surface Repair

This category generally requires deeper cutting than leveling. It consists of removing isolated distressed pavement sections down to subbase, if necessary, prior to adding new overlay materials. Since the cutter mandrel on Cat cold planers cuts forward and upward, there's no damaging impact to the underlying base.

Pavement Removal

Pavement buildup is a problem that plagues most older streets, roads and highways. As overlays are added, curbs and drains are buried — creating drainage problems. Overhead clearances are dangerously reduced ... and additional weight is added to over-passes and bridges. Cold planing is an economical method of curing all these problems.

Surface Texturing

Serious accidents increase when pavement becomes slick from wear. The textured surface produced by cold planing is highly skid-resistant and has dramatically reduced hydroplaning characteristics.

Pavement Mining

Cold milling has made it practical to actually “mine” deteriorated pavement materials from existing roads and streets. The cold planer produces an ideally-sized asphalt or concrete material which can be recycled in a variety of ways. Depending on type, age and condition of pavement, the largest cold planer can reclaim up to 900 tons of material per hour.

COLD PLANER USE BY PROJECT TYPE

Applications	Highway/Airport	City/Urban
Planing (Milling)	<ul style="list-style-type: none"> ● To establish grade and slope. ● Remove excess pavement. 	<ul style="list-style-type: none"> ● To establish proper grade and slope. ● To establish new grade and slope.
Partial Removal	<ul style="list-style-type: none"> ● For use with hot mix recycle. ● Remove pavement irregularities. ● Texture for skid resistance. 	<ul style="list-style-type: none"> ● To correct drainage and curb reveal. ● To lower elevation at overpass. ● For use with hot recycle. ● Eliminate leveling course.
Full Depth Removal	<ul style="list-style-type: none"> ● Total rebuild. RAP used for base or hot recycle. ● Cold recycle. This requires additional surface treatment. 	<ul style="list-style-type: none"> ● Total rebuild. RAP used for base or hot recycle. ● Cold recycle. Requires additional surface treatment.
Texturing	<ul style="list-style-type: none"> ● For skid resistance and improved bond when overlay is applied. 	<ul style="list-style-type: none"> ● For skid resistance and improved bond when overlay is applied.
Leveling		<ul style="list-style-type: none"> ● At intersections to remove bumps, shoving and improve drainage.
Special	<ul style="list-style-type: none"> ● Joint and crack repair. ● Cut rumble grooves on shoulders of bridge approaches. ● Concrete removal. 	<ul style="list-style-type: none"> ● Intersection defect repair. ● Pothole repair. ● Railroad crossing repair. ● Tight radius profiling around manhole covers, etc. ● Pavement adjustments (transitions from existing pavements to new overlays).

RM300 and RM500B:

The RM300 and the RM500B combine superior performance and reliability to achieve the most demanding job specifications while maximizing machine uptime. With many enhanced features and options, the RM300 and the RM500B are designed to work well in both full depth reclamation and soil stabilization applications.

Rotary Mixers**Sustainability:**

- Long-lasting lubricants and fluids extend maintenance intervals, decreasing the amount of waste and filters contributed to environment.
- Ecology drains provide a simple means to drain machine fluids with a minimized risk of spillage.
- Maintenance free Cat batteries are recyclable.
- Cat ACERT engines meet applicable emission standards.
- Rotary Mixers recycle the materials into aggregate on site. That reduces overall fuel consumption and engine emissions.
- Rotary Mixers and the reclamation process can eliminate the need for an excavator and motor grader at most job sites.
- Rotary Mixers can reclaim and stabilize simultaneously. If stabilization is required, the agent can be placed on top of the reclamation project. The Rotary Mixer then makes a single pass, mixing the stabilizer with the material beneath the surface. At the same time, it reduces the aggregate to its original size. All this is accomplished with one machine — in one pass.
- The reclamation and stabilization process can easily incorporate environmentally sensitive sealants. Now the life of the road bases can be extended without fear of harming wildlife.

- The reclamation process usually is quicker than full replacement, allowing roads to open sooner. This means fewer traffic jams — a quality of life issue as well.
- Reclamation and stabilization dramatically extend the life of roads. Some contractors conservatively estimate that a reclaimed/stabilized base will help a recycled road last 30 to 40 years. Extending that life is an enormous cost-saver, and also results in the use of less energy.

RM300 Features:

- **Maximum Production** ... from Cat ACERT engines.
- **Highly Efficient** ... load-sensing propel system helps prevent overloading while allowing continuous work near rated horsepower.
- **Extremely Versatile** ... interchangeable rotors provide both reclamation and stabilization capabilities.
- **Consistent Blending** ... automatic depth control, mid-mounted mixing chamber and multi-speed rotor drive combine for optimum blending and increased production.

RM500B Features:

- **Maximum Production** ... from Cat ACERT engines.
- **Highly Maneuverable** ... separate hydraulic pump provides hydraulic flow to large displacement motors on each rear wheel.
- **Versatility** ... choice of three rotors for full depth reclamation or soil stabilization.
- **Reliability** ... field proven Cat components maximize machine availability.
- **Standard all-wheel drive with advanced traction control system** for maximum traction.
- **Rotating operator's station with handwheel steering and integrated touchscreen display** provides operator with fingertip control, high visibility and exceptional comfort.

MODEL	RM300		RM500B	
Gross Power	261 kW	350 hp	407 kW*	546 hp*
Operating Weight with ROPS, cab and universal rotor	24 454 kg	53,911 lb	28 553 kg	62,950 lb
Engine Model	C11 ACERT		C15 ACERT	
Emission Standards	Tier 3/Stage IIIA equivalent		Tier 4 Final/Stage IV*	
Rated Engine RPM	1800		2000	
No. Cylinders	6		6	
Bore	130 mm	5.1"	137.2 mm	5.4"
Stroke	140 mm	5.5"	171.4 mm	6.75"
Displacement	11.1 L	680 in³	15.1 L	921.5 in³
Drive Systems: Rotor	3 Speed Chain		3 Speed Chain	
Propel	Hydrostatic/Planetary		Hydrostatic/Planetary	
Operating Dimensions: Height	3500 mm	11'6"	3480 mm	11'4"
Width	3000 mm	9'10"	2980 mm	9'7"
Length	10 000 mm	32'10"	10 320 mm	33'10"
Width of Cut	2438 mm	8'0"	2438 mm	8'0"
Depth of Cut (Max.)	457 mm	18"	508 mm	20"
Rotor Speed	@ 1800 engine rpm		@ 2000 engine rpm	
	First	106 rpm	First	115 rpm
	Second	144 rpm	Second	160 rpm
	Third	216 rpm	Third	215 rpm
Minimum Turning Radius:				
Standard	3900 mm	12'10"	4330 mm	14'2"
Travel Speed (Max.): Working	4.3 km/h	2.7 mph	3.3 km/h	2 mph
Roading	9.7 km/h	6.0 mph	10.5 km/h	6.5 mph
Standard Tires: Front	28.1 × 26 18-ply Lug Type R-1		725/70-25 — L-4	
Rear	18.4 × 30 12-ply Lug Type R-1		23.1-26 LS-2	
Fuel Capacity	1056 L	279 U.S. gal	1506 L	279 U.S. gal
Diesel Exhaust Fluid Refill Capacity	—		46 L	12.2 U.S. gal
Cooling System	62.5 L	16.5 U.S. gal	80 L	21.1 U.S. gal
Crankcase	32 L	8.5 U.S. gal	34 L	8.9 U.S. gal

*402 kW (540 hp), Tier 3/Stage IIIA equivalent emission standards in some markets.

Rotor Options for RM300 and RM500B

Rotor	Maximum Depth of Work	No. of Bits/Tools	Direction of Cut	Stabilization	Reclamation
Universal 406 mm (16")*	406 mm 16"	200	Up	X	X
Universal 457 mm (18")**	457 mm 18"	200	Up	X	X
Soil	508 mm 20"	238	Up	X	
Combination	508 mm 20"	114	Up	X	
Spade	457 mm 18"	58	Up	X	

*Designed to produce maximum breakout force, the Universal Rotor 406 mm (16") performs well in severe asphalt cuts.

**The Universal Rotor 457 mm (18") is designed to provide maximum mixing depth and has lower breakout force compared to the Universal Rotor 406 mm (16").

Rotor Options:

Some rotor options are not available in certain markets.

- **Soil Rotor** is designed primarily for use in soil stabilization.
- **Combination Rotor** is designed primarily for use in soil stabilization with a secondary application in light cuts of asphalt reclamation.
- **Universal Rotor** can be used for either reclamation or stabilization.
- **Spade Rotor** is designed for soil stabilization applications.

PRODUCTION ESTIMATING

The maximum cutting depth is 381 mm (15 in) for the RM300 and 457 mm (18 in) for the RM500B. The RM300 can mix up to 457 mm (18 in). In addition, the cutting width of their rotors is 2.4 m (8 ft). The following formulas allow you to determine the production in square yards (yd²)/minute or cubic yards (yd³)/minute.

Production in square yards (yd²) per minute

$$\text{yd}^2/\text{min} = \frac{\text{FPM of travel speed}}{1.125}$$

$$\frac{9 \text{ ft}^2/\text{yd}^2}{8 \text{ ft Cutting width}} = 1.125 \text{ (This is a constant value for an eight foot wide rotor)}$$

Gallons of additive (for units with pump and metering additive system)

$$\frac{\text{GPM}}{\text{yd}^2/\text{min}} = \text{gal}/\text{yd}^2$$

Or, if required additive amounts are known, you can determine necessary travel speed as shown:

$$\frac{\text{GPM}}{\text{gal}/\text{yd}^2} = \text{yd}^2/\text{min}; \text{yd}^2/\text{min} \times 1.125 = \text{ft}/\text{min}$$

Production in Cubic Yards (yd³) per minute

$$\frac{\text{FPM of travel speed}}{1.125} \times \frac{\text{Cutting or mixing depth in inches}}{36} = \frac{\text{yd}^3}{\text{min}}$$

Production in Tons per Minute

$$\text{yd}^3/\text{min} \times \frac{\text{Wt. of Material per yd in lbs}}{2000 \text{ lb}/\text{ton}} = \text{tons}/\text{min}$$

Abbreviations

FPM = Feet Per Minute
GPM = Gallons Per Minute

WEIGHT OF MATERIALS

Material	LOOSE		IN-PLACE		
	kg/m ³	lb/yd ³	kg/m ³	lb/yd ³	
Clay	— Dry	1480	2500	1840	3100
	— Wet	1660	2800	2080	3500
Clay and Gravel	— Dry	1420	2400	1660	2800
	— Wet	1540	2600	1840	3100
Sand and Gravel	— Dry	1720	2900	1930	3250
	— Wet	2020	3400	2220	3750
Sand	— Dry	1420	2400	1600	2700
	— Damp	1690	2850	1900	3200
	— Wet	1840	3100	2080	3500
Earth	— Dry Packed	1510	2550	1900	3200
	— Wet Excavated	1600	2700	2020	3400
	— Top Soil	950	1600	1360	2300
	— Loam	1250	2100	1540	2600
Bituminous Concrete	— Windrowed Chunks (25% Voids)	1740	2925	—	—
	— Compacted	—	—	2310	3900

STABILIZATION/RECLAMATION PRODUCTION

The following charts list production in square meters per minute, square yards per minute, cubic meters per minute, and cubic yards per minute. The information is based on various travel speeds and cutting depths for Cat Rotary Mixers equipped with a 2438 mm (8 ft) cutting rotor.

		PRODUCTION RATES																
Travel Speed m/ min	m ² /min	m ³ /minute																
		Cutting Depth — mm																
		100	125	150	175	200	225	250	275	300	325	350	375	400	425	450	475	500
3	7.3	0.73	0.9	1.1	1.3	1.5	1.6	1.8	2.0	2.2	2.4	2.6	2.7	2.9	3.1	3.3	3.5	3.7
6	14.6	1.46	1.8	2.2	2.6	2.9	3.3	3.7	4.0	4.4	4.8	5.1	5.5	5.9	6.2	6.6	6.9	7.3
9	21.9	2.2	2.7	3.3	3.8	4.4	4.9	5.5	6.0	6.6	7.1	7.7	8.2	8.8	9.3	9.9	10.4	11.0
12	29.3	2.9	3.7	4.4	5.1	5.9	6.6	7.3	8.0	8.8	9.5	10.2	11.0	11.7	12.4	13.2	13.9	14.6
15	36.6	3.6	4.6	5.5	6.4	7.3	8.2	9.1	10.0	11.0	11.9	12.8	13.7	14.6	15.5	16.5	17.4	18.3
18	43.9	4.4	5.5	6.6	7.7	8.8	9.9	11.0	12.1	13.2	14.3	15.4	16.5	17.6	18.7	19.7	20.8	21.9
21	51.2	5.1	6.4	7.7	9.0	10.2	11.5	12.8	14.1	15.4	16.6	17.9	19.2	20.5	21.8	23.0	24.3	25.6
24	58.5	5.9	7.3	8.8	10.2	11.7	13.2	14.6	16.1	17.6	19.0	20.5	21.9	23.4	24.9	26.3	27.8	29.3
27	65.8	6.6	8.2	9.9	11.5	13.2	14.8	16.4	18.1	19.7	21.4	23.0	24.7	26.3	28.0	29.6	31.3	32.9

		PRODUCTION RATES																
Travel Speed ft/ min	yd ² /min	yd ³ /minute																
		Cutting Depth — inches																
		4	5	6	7	8	9	10	11	12	13	14	15	16	17	18	19	20
10	8.9	0.98	1.2	1.5	1.7	2.0	2.2	2.5	2.7	3.0	3.2	3.5	3.7	4.0	4.2	4.5	4.7	4.9
20	17.8	1.96	2.5	3.0	3.4	4.0	4.4	4.9	5.5	5.9	6.4	6.9	7.4	7.9	8.4	8.9	9.4	9.9
30	26.7	2.9	3.7	4.5	5.2	5.9	6.7	7.4	8.2	8.9	9.6	10.4	11.1	11.9	12.6	13.4	14.0	14.8
40	35.6	3.9	4.9	5.9	6.9	7.9	8.9	9.9	10.9	11.9	12.8	13.9	14.8	15.8	16.8	17.8	18.7	19.8
50	44.5	4.9	6.2	7.4	8.6	9.9	11.1	12.4	13.6	14.8	16.0	17.3	18.5	19.8	21.0	22.3	23.4	24.7
60	53.4	5.9	7.4	8.9	10.3	11.9	13.3	14.8	16.4	17.8	19.2	20.8	22.2	23.7	25.2	26.7	28.1	29.7
70	62.3	6.8	8.6	10.4	12.0	13.8	15.6	17.3	19.1	20.8	22.4	24.3	25.9	27.7	29.5	31.2	32.8	34.6
80	71.2	7.8	9.9	11.9	13.7	15.8	17.8	19.8	21.8	23.7	25.6	27.7	29.6	31.6	33.7	35.6	37.5	39.6
90	80.1	8.8	11.1	13.4	15.5	17.8	20.0	22.4	24.5	26.7	28.8	31.2	33.3	35.6	37.9	40.1	42.1	44.5

Asphalt Pavers**Sustainability:**

- Long-lasting lubricants and fluids extend maintenance intervals, decreasing the amount of waste and filters contributed to environment.
- Ecology drains provide a simple means to drain machine fluids with a minimized risk of spillage.
- Maintenance free Cat batteries are recyclable.
- Cat ACERT engines meet applicable emission standards.
- Proprietary undercarriage design on Mobil-Trac™ pavers significantly reduces track belt wear, reducing frequency of replacement.
- Cat electric-heated screeds provide a reduction in engine emissions, which not only reduces the impact to the environment, but helps prevent soot build-up on indicators and decals — for enhanced safety.
- Electric-heated screeds produce less noise, which is appreciated by the crew as well as those who work and live near the construction sites.
- Electric-heated screeds, unlike their diesel counterparts, don't require a constant flame — another way emissions are reduced, and operators spared some heat.
- Electric-heated screeds are lighter, which means the paver consumes less fuel.
- Electric-heated screeds warm up quickly, another energy saver.
- Pavers equipped with Eco-mode can reduce engine speed to increase fuel efficiency during normal operation conditions.
- Pavers equipped with automatic engine speed control can be programmed to idle the engine when machine is in neutral for a predetermined amount of time, reducing fuel burn.

Features:

- **Variable width screeds** available.
- **Self-dumping hydraulic hoppers** are heavy-duty and high capacity.
- **Soldered and molded** electrical connections.
- **Self diagnostics** on propel and feeder systems.
- **Electrically heated screeds.**
- **Dual independent operating stations.**
- **Mobil-Trac undercarriage** provides speed of a wheeled paver with maneuverability of a track paver.
- **Optional Cat Grade and Slope** is integrated with the paver.
- **Large generators** deliver fast heat with less fuel consumption.*
- **One-touch functions** for cleanout/warm up mode.*
- **One-touch Auto-fill function.***
- **One-touch feeder system activation.***
- **Advanced generator diagnostics** helps determine heating element life.*

*Feature available on F Series pavers only.

MODEL	AP300D		AP500E		AP500E*	
Gross Power	55.5 kW	74.4 hp	106 kW	142 hp	106 kW	144 hp
Rated Engine RPM	2200		2200		2200	
No. Cylinders	4		4		4	
Displacement	4.4 L	269 in³	4.4 L	269 in³	4.4 L	269 in³
Engine Model	C4.4 ACERT		C4.4 ACERT		C4.4 ACERT	
Emission Standards	Tier 3/Stage IIIA equivalent		Tier 3/Stage IIIA equivalent		Tier 3/Stage IIIA equivalent	
Operating Weight (Tractor)	6300 kg	13,889 lb	12 590 kg	27,760 lb	16 145 kg	35,600 lb
Speeds:						
Paving (Vibratory Screed)	30 m/min	98 ft/min	61 m/min	200 ft/min	61 m/min	200 ft/min
Paving (Tamper Bar Screed)	—		25 m/min	82 ft/min	25 m/min	82 ft/min
Travel	16 km/h	10 mph	16 km/h	10 mph	16 km/h	10 mph
Tires:						
Front (4)	455 × 260 Solid Rubber		13 × 22 Solid Rubber		13 × 22 Solid Rubber	
Rear (2)	365/80 R20		17.5 R25		17.5 R25	
Dimensions:						
Standard Paving Width	1.70 m	5'7"	2.44 m	8'0"	2.44 m	8'0"
Shipping Width (maximum)	1.73 m	5'8"	2.72 m	8'11"	2.72 m	8'11"
Height (less exhaust)	2.62 m	8'7"	2.82 m	9'3"	2.82 m	9'3"
Approximate Length (with push roller and screed)	4.87 m	16'0"	5.80 m	19'0"	5.80 m	19'0"
Turning Radius	0.3 m	1'0"	0.75 m	2'6"	0.75 m	2'6"
Wheelbase	1950 mm	6'5"	2297 mm	7'7"	2297 mm	7'7"
Hopper Capacity	3.8 m ³	134 ft³	6.2 m ³	219 ft³	6.2 m ³	219 ft³
Auger Diameter	260 mm	10"	406 mm	16"	406 mm	16"
Available Screeds:						
AS3173		X		—		—
AS4173		X		—		—
AS3251C		—		X		—
AS4251C		—		—		X
AS4252C		—		—		X
SE50 V		—		—		—
SE50 VT		—		—		—
SE60 V		—		—		—
SE60 V XW		—		—		—
SE60 VT XW		—		—		—
Service Refill Capacities:						
Cooling System	15 L	4 U.S. gal	30 L	7.9 U.S. gal	30 L	7.9 U.S. gal
Fuel Tank	79.5 L	21 U.S. gal	189 L	50 U.S. gal	189 L	50 U.S. gal
Hydraulic Oil Tank	150 L	40 U.S. gal	170 L	45 U.S. gal	170 L	45 U.S. gal

*Model available in Europe, Africa and the Middle East only.

MODEL	AP600F		AP600F		AP1000F	
Gross Power	151 kW	202 hp	129 kW	175 hp	168 kW	225 hp
Rated Engine RPM	2200		2200		2200	
No. Cylinders	6		4		6	
Displacement	7.1 L	427.7 in ³	4.4 L	268.5 in ³	7.1 L	427.7 in ³
Engine Model	C7.1 ACERT		C4.4 ACERT		C7.1 ACERT	
Emission Standards	Tier 3/Stage IIIA equivalent		Tier 4 Final/Stage IV		Tier 4 Final/Stage IV	
Operating Weight (Tractor)	13 845 kg	30,522 lb	13 845 kg	30,522 lb	15 889 kg	35,030 lb
Speeds:						
Paving (Vibratory Screed)	76 m/min	250 ft/min	76 m/min	250 ft/min	76 m/min	250 ft/min
Paving (Tamper Bar Screed)	25 m/min	82 ft/min	25 m/min	82 ft/min	25 m/min	82 ft/min
Travel	0-16 km/h	0-10 mph	0-16 km/h	0-10 mph	0-19.9 km/h	0-12 mph
Tires:						
Front (4)	13 × 22 Solid Rubber		13 × 22 Solid Rubber		16 × 22 Solid Rubber	
Rear (2)	16 × 25		16 × 25		18.00 R25	
Dimensions:						
Standard Paving Width	2550 mm	8'4"	2550 mm	8'4"	3200 mm	10'6"
Shipping Width (maximum)	3211 mm	10'6"	3211 mm	10'6"	3211 mm	10'6"
Height (less exhaust)	2997 mm	9'10"	2997 mm	9'10"	2929 mm	9'7"
Approximate Length (with push roller and screed)	6825 mm	22'5"	6825 mm	22'5"	7034 mm	23'1"
Turning Radius	1500 mm	4'6"	1500 mm	4'6"	500 mm	1'6"
Wheelbase	2776 mm	9'1"	2776 mm	9'1"	2776 mm	9'1"
Hopper Capacity	7.1 m ³	250 ft ³	7.1 m ³	250 ft ³	8.1 m ³	286 ft ³
Auger Diameter	406 mm	16"	406 mm	16"	406 mm	16"
Available Screeds:						
AS3173		—		—		—
AS4173		—		—		—
AS3251C		—		—		—
AS4251C		—		—		—
AS4252C		—		—		—
SE50 V		X		X		—
SE50 VT		X		X		—
SE60 V		X		X		X
SE60 V XW		—		—		X
SE60 VT XW		—		—		X
Service Refill Capacities:						
Cooling System	37 L	9.8 U.S. gal	31 L	8 U.S. gal	45.4 L	12 U.S. gal
Fuel Tank	278 L	73 U.S. gal	278 L	73 U.S. gal	348 L	92 U.S. gal
Diesel Exhaust Fluid Refill Capacity		—	19.1 L	5 U.S. gal	37.8 L	10 U.S. gal
Hydraulic Oil Tank	219 L	58 U.S. gal	219 L	58 U.S. gal	219 L	58 U.S. gal

MODEL	AP255E		AP555E		AP555E*	
Gross Power	34.1 kW	45.7 hp	106 kW	142 hp	106 kW	144 hp
Rated Engine RPM	2400		2200		2200	
No. Cylinders	4		4		4	
Displacement	2.2 L	134.3 in ³	4.4 L	269 in ³	4.4 L	269 in ³
Engine Model	C2.2		C4.4 ACERT		C4.4 ACERT	
Emission Standards	Tier 4 Interim/ Stage IIIB equivalent		Tier 3/ Stage IIIA equivalent		Tier 3/ Stage IIIA equivalent	
Operating Weight (Tractor):						
with Mobil-Trac	—		13 305 kg	29,335 lb	13 675 kg	30,148 lb
with Steel Track	4500 kg	9921 lb	—		—	
Maximum Speeds:						
Paving (Mobil-Trac)	—		61 m/min	200 ft/min	25 m/min	82 ft/min
(Steel Track)	33 m/min	108.3 ft/min	—		—	
Travel (Mobil-Trac)	—		11 km/h	7 mph	11 km/h	7 mph
(Steel Track)	16 km/h	9.9 mph	—		—	
Tracks Assemblies:						
Width (Mobil-Trac)	—		406 mm	16"	406 mm	16"
(Steel Track)	200 mm	7.9"	—		—	
Length on Ground (Mobil-Trac)	—		2460 mm	8'1"	2460 mm	8'1"
(Steel Track)	1420 mm	4'8"	—		—	
Dimensions:						
Standard Paving Width	1.4 m	4'7"	2.44 m	8'0"	2.55 m	8'4"
Shipping Width (maximum)	1.6 m	5'3"	2.44 m	8'0"	2.50 m	8'2"
Height (less exhaust)	1.8 m	5'11"	2.82 m	9'3"	3.10 m	10'2"
Length (screed, push roller)	4.04 m	13'3"	5.80 m	19'0"	5.75 m	18'10"
Turning Radius	0.7 m	2'4"	304 mm	12"	304 mm	12"
Hopper Capacity	3.1 m ³	109.5 ft ³	6.2 m ³	219 ft ³	6.2 m ³	219 ft ³
Auger Diameter	260 mm	10.2"	406 mm	16"	406 mm	16"
Available Screens:						
AS3143	X		—		—	
AS3251C	—		X		—	
AS4251C	—		—		X	
AS4252C	—		—		X	
SE50 V	—		—		—	
SE50 VT	—		—		—	
SE60 V	—		—		—	
SE60 V XW	—		—		—	
SE60 VT XW	—		—		—	
Service Refill Capacities:						
Cooling System	17 L	4.5 U.S.gal	30 L	7.9 U.S. gal	30 L	7.9 U.S. gal
Fuel Tank	65 L	17.2 U.S.gal	189 L	50 U.S. gal	189 L	50 U.S. gal
Hydraulic Oil Tank	73 L	19.3 U.S.gal	170 L	45 U.S. gal	170 L	45 U.S. gal

*Model available in Europe, Africa, Middle East and Asia only.

MODEL	AP655F		AP655F		AP1055F		AP1055F	
Gross Power	151 kW	202 hp	129 kW	175 hp	186 kW	249 hp	168 kW	225 hp
Rated Engine RPM	2200		2200		2200		2200	
No. Cylinders	6		4		6		6	
Displacement	7.1 L	427.7 in³	4.4 L	268.5 in³	7.1 L	427.7 in³	7.1 L	427.7 in³
Engine Model	C7.1		C4.4 ACERT		C7.1		C7.1 ACERT	
Emission Standards	Tier 3/ Stage IIIA equivalent		Tier 4 Final/ Stage IV		Tier 3/ Stage IIIA equivalent		Tier 4 Final/ Stage IV	
Operating Weight (Tractor):								
with Mobil-Trac	15 584 kg	34,356 lb	15 584 kg	34,356 lb	17 056 kg	37,608 lb	17 056 kg	37,608 lb
with Steel Track	16 043 kg	35,368 lb	16 043 kg	35,368 lb	—	—	—	—
Maximum Speeds:								
Paving (Mobil-Trac)	64 m/min	210 ft/min	64 m/min	210 ft/min	64 m/min	210 ft/min	64 m/min	210 ft/min
(Steel Track)	49 m/min	160 ft/min	49 m/min	160 ft/min	—	—	—	—
Travel (Mobil-Trac)	14.5 km/h	9 mph	14.5 km/h	9 mph	14.5 km/h	9 mph	14.5 km/h	9 mph
(Steel Track)	6.5 km/h	4 mph	6.5 km/h	4 mph	—	—	—	—
Tracks Assemblies:								
Width (Mobil-Trac)	406 mm	16"	406 mm	16"	457 mm	18"	457 mm	18"
(Steel Track)	356 mm	14"	356 mm	14"	—	—	—	—
Length on Ground:								
(Mobil-Trac)	3020 mm	9'11"	3020 mm	9'11"	3136 mm	10'3"	3136 mm	10'3"
(Steel Track)	3048 mm	10'0"	3048 mm	10'0"	—	—	—	—
Dimensions:								
Standard Paving Width	2550 mm	8'4"	2550 mm	8'4"	3200 mm	10'6"	3200 mm	10'6"
Shipping Width (maximum)	3211 mm	10'6"	3211 mm	10'6"	3211 mm	10'6"	3211 mm	10'6"
Height (less exhaust)	2997 mm	9'10"	2997 mm	9'10"	2929 mm	9'7"	2929 mm	9'7"
Length (screed, push roller)	6910 mm	22'8"	6910 mm	22'8"	7034 mm	23'1"	7034 mm	23'1"
Turning Radius	304 mm	12"	304 mm	12"	0 mm	0"	0 mm	0"
Hopper Capacity	7.1 m ³	250 ft³	7.1 m ³	250 ft³	8.1 m ³	286 ft³	8.1 m ³	286 ft³
Auger Diameter	406 mm	16"	406 mm	16"	406 mm	16"	406 mm	16"
Available Screens:								
AS3143	—	—	—	—	—	—	—	—
AS3251C	—	—	—	—	—	—	—	—
AS4251C	—	—	—	—	—	—	—	—
AS4252C	—	—	—	—	—	—	—	—
SE50 V	X	X	X	X	—	—	—	—
SE50 VT	X	X	X	X	—	—	—	—
SE60 V	X	X	X	X	X	X	X	X
SE60 V XW	X	X	X	X	X	X	X	X
SE60 VT XW	X	X	X	X	X	X	X	X
Service Refill Capacities:								
Cooling System	37 L	9.8 U.S. gal	31 L	8 U.S. gal	45.4 L	12 U.S. gal	45.4 L	12 U.S. gal
Fuel Tank	278 L	73 U.S. gal	278 L	73 U.S. gal	348 L	92 U.S. gal	348 L	92 U.S. gal
Diesel Exhaust Fluid Refill Capacity	—	—	19.1 L	5 U.S. gal	—	—	19.1 L	5 U.S. gal
Hydraulic Oil Tank	219 L	58 U.S. gal	219 L	58 U.S. gal	219 L	58 U.S. gal	219 L	58 U.S. gal

MODEL	AS3143		AS3173		AS4173	
Standard Paving Width	1.40 m	4'7"	1.70 m	5'7"	1.75 m	5'9"
Paving Ranges:						
Hydraulically Extendible (maximum)	2.60 m	8'6"	3.20 m	10'6"	3.42 m	11'2"
With Bolt-on Extensions (maximum)	3.40 m	11'2"	4.00 m	13'1"	4.00 m	13'1"
With Cutoff Shoes (minimum)	0.15 m	6"	0.65 m	2'2"	0.70 m	2'4"
Extender Mounting		Rear		Rear		Rear
Tamper System		—		—		X
Vibration System		X		X		—
Length:						
Without End Gates (front to rear)		—	1.00 m	3'3"		—
With End Gates (front to rear)		—	1.70 m	5'7"		—
Width:						
Without End Gates		—	1.67 m	5'6"	1.75 m	5'9"
With End Gates		—	1.73 m	5'8"	1.90 m	6'3"
Height	0.94 m	3'1"	1.55 m	5'1"		—
Weights:						
Diesel Heat Screed		—		—		—
LPG Heat Screed		—	1300 kg	2866 lb		—
Electric Heat Screed		NA	1330 kg	2932 lb	1800 kg	3968 lb

MODEL	A3251C		AS4251C		AS4252C	
Standard Paving Width	2.44 m	8'0"	2.55 m	8'4"	2.55 m	8'4"
Paving Ranges:						
Hydraulically Extendible (maximum)	4.75 m	15'6"	5.00 m	16'5"	5.00 m	16'5"
With Bolt-on Extensions (maximum)	6.15 m	20'2"	8.00 m	26'3"	8.00 m	26'3"
With Cutoff Shoes (minimum)	1.83 m	6'0"		—		—
Extender Mounting		Rear		Rear		Rear
Tamper System		—		X		X
Vibration System		X		X		X
Length:						
Without End Gates (front to rear)	1.78 m	5'10"	1.58 m	5'6"	1.58 m	5'6"
With End Gates (front to rear)	2.08 m	6'10"	2.26 m	7'5"	2.26 m	7'5"
Width:						
Without End Gates	2.46 m	8'1"	2.55 m	8'2"	2.55 m	8'2"
With End Gates	2.70 m	8'10"	2.73 m	8'11"	2.73 m	8'11"
Height	2.15 m	7'1"	1.52 m	5'0"	1.52 m	5'0"
Weights:						
Diesel Heat Screed		—	3840 kg	8467 lb		—
LPG Heat Screed		—		—		—
Electric Heat Screed	2925 kg	6450 lb	3840 kg	8467 lb	3395 kg	7485 lb

MODEL	SE50 V		SE50 VT		SE60 V	
Standard Paving Width	2.55 m	8'4"	2.55 m	8'4"	3.00 m	9'10"
Paving Ranges:						
Hydraulically Extendible (maximum)	5.00 m	16'4"	5.00 m	16'4"	6.00 m	19'6"
With Bolt-on Extensions (maximum)	6.50 m	21'4"	8.00 m	26'4"	7.65 m	25'0"
With Cutoff Shoes (minimum)	—		—		—	
Extender Mounting	Rear		Rear		Rear	
Tamper System	—		X		—	
Vibration System	X		—		X	
Length:						
Without End Gates (front to rear)	—		—		—	
With End Gates (front to rear)	—		—		—	
Width:						
Without End Gates	2.55 m	8'4"	2.55 m	8'4"	3.21 m	10'6"
With End Gates	2.76 m	9'1"	2.76 m	9'1"	3.21 m	10'6"
Height	—		—		2.30 mm	7'7"
Weights:						
Diesel Heat Screed	—		—		—	
LPG Heat Screed	—		—		—	
Electric Heat Screed	3284 kg	7239 lb	3340 kg	7363 lb	3400 kg	7495 lb

MODEL	SE60 V XW		SE60 VT XW	
Standard Paving Width	3.00 m	9'10"	3.00 m	9'10"
Paving Ranges:				
Hydraulically Extendible (maximum)	6.00 m	19'6"	6.00 m	19'6"
With Bolt-on Extensions (maximum)	10.00 m	33'0"	10.00 m	33'0"
With Cutoff Shoes (minimum)	—		—	
Extender Mounting	Rear		Rear	
Tamper System	—		X	
Vibration System	X		—	
Length:				
Without End Gates (front to rear)	1.78 m	5'10"	1.78 m	5'10"
With End Gates (front to rear)	2.50 m	8'3"	2.50 m	8'3"
Width:				
Without End Gates	3.21 m	10'6"	3.21 m	10'6"
With End Gates	3.21 m	10'6"	3.21 m	10'6"
Height	2.30 mm	7'7"	2.30 mm	7'7"
Weights:				
Diesel Heat Screed	—		—	
LPG Heat Screed	—		—	
Electric Heat Screed	4070 kg	8973 lb	4490 kg	7695 lb

ASPHALT PAVING CHARTS

These charts will assist you when trying to match plant output with paving speeds. Keep in mind when using these charts, it will be at 100% efficiency. If you know efficiency, multiply T.P. hour × efficiency. (Example: 75% efficiency at 300 T.P.H. – 300 × 0.75 = 225 T.P.H.)

Production in tons/hr with 1" compacted mat

Speed	Paving Widths						
ft/min	6'0"	7'0"	8'0"	9'0"	10'0"	11'0"	12'0"
10	22	26	29	33	37	40	44
20	44	51	58	66	73	80	88
30	66	77	87	99	110	120	131
40	88	102	116	131	146	161	175
50	110	129	145	164	183	201	219

Production in tons/hr with 2" compacted mat

Speed	Paving Widths						
ft/min	6'0"	7'0"	8'0"	9'0"	10'0"	11'0"	12'0"
10	44	52	58	66	74	80	88
20	88	176	116	132	146	160	176
30	132	154	174	198	220	240	262
40	176	204	232	262	292	322	350
50	220	258	290	328	366	402	438

Production in tons/hr with 3" compacted mat

Speed	Paving Widths						
ft/min	6'0"	7'0"	8'0"	9'0"	10'0"	11'0"	12'0"
10	66	78	87	99	111	120	132
20	132	153	174	198	219	240	284
30	198	231	261	297	330	360	393
40	264	306	348	393	438	483	525
50	330	387	435	492	549	603	657

Production in tons/hr with 4" compacted mat

Speed	Paving Widths						
ft/min	6'0"	7'0"	8'0"	9'0"	10'0"	11'0"	12'0"
10	88	104	116	132	148	160	176
20	176	204	232	264	292	320	352
30	264	308	348	396	440	480	524
40	352	408	464	524	584	644	700
50	440	516	580	656	732	804	876

Slope Conversion Table

Percent	Inches per foot	Inches per 12 foot	Percent	Inches per foot	Inches per 12 foot
0.17%		1/4	5.21%	5/8	7 1/2
0.35%		1/2	5.38%		7 3/4
0.52%	1/16	3/4	5.56%		8
0.70%		1	5.73%	11/16	8 1/4
0.87%		1 1/4	5.90%		8 1/2
1.04%	1/8	1 1/2	6.08%		8 3/4
1.22%		1 3/4	6.25%	3/4	9
1.39%		2	6.42%		9 1/4
1.56%	3/16	2 1/4	6.60%		9 1/2
1.74%		2 1/2	6.77%	13/16	9 3/4
1.91%		2 3/4	6.94%		10
2.08%	1/4	3	7.12%		10 1/4
2.26%		3 1/4	7.29%	7/8	10 1/2
2.43%		3 1/2	7.47%		10 3/4
2.60%	5/16	3 3/4	7.64%		11
2.78%		4	7.81%	15/16	11 1/4
2.95%		4 1/4	7.99%		11 1/2
3.13%	3/8	4 1/2	8.16%		11 3/4
3.30%		4 3/4	8.33%	1	12
3.47%		5	8.51%		12 1/4
3.65%	7/16	5 1/4	8.68%		12 1/2
3.82%		5 1/2	8.85%	1 1/16	12 3/4
3.99%		5 3/4	9.03%		13
4.17%	1/2	6	9.20%		13 1/4
4.34%		6 1/4	9.38%	1 1/8	13 1/2
4.51%		6 1/2	9.55%		13 3/4
4.69%	9/16	6 3/4	9.72%		14
4.86%		7	9.90%	1 3/16	14 1/4
5.04%		7 1/4	10.07%		14 1/2

Formula:

$$\text{Percent} = \frac{\text{Inches per foot} \times 100}{12}$$

Inches in decimals of a foot

1/16 = .0052	1 = .0833
3/32 = .0078	2 = .1667
1/8 = .0104	3 = .2500
3/16 = .0156	4 = .3333
1/4 = .0208	5 = .4167
5/16 = .0260	6 = .5000
3/8 = .0313	7 = .5833
1/2 = .0417	8 = .6667
5/8 = .0521	9 = .7500
3/4 = .0625	10 = .8333
7/8 = .0729	11 = .9167

Vibratory and Pneumatic Tire Compactors

Sustainability:

- Long-lasting lubricants and fluids extend maintenance intervals, decreasing the amount of waste and filters contributed to environment.
- Ecology drains provide a simple means to drain machine fluids with a minimized risk of spillage.
- Maintenance free Cat batteries are recyclable.
- Cat ACERT engines meet applicable emission standards.
- Biodegradable oil option available.

General Compactor Features:

- **Routine maintenance** simplified by grouped service points and easy access to service areas.
- **Operator stations** designed for maximum comfort, easy control, and optimal visibility.
- **Direct hydrostatic drive to front (drums or wheels) and rear (drums or wheels)** provides dependable, responsive, propulsion effort and maximum gradeability. (Does not include pneumatic tire compactors.)
- **Eco-mode standard equipment** on B Series Vibratory Soil Compactors and Double Drum Rollers reduces fuel consumption.

Vibratory Compactor Features:

Single Drum

- **Dual pump system** delivers positive tractive effort to both drum and rear wheels, regardless of underfooting. This increases the machine's ability to maneuver in a wide variety of soil types and conditions and improves gross gradeability.
- **Limited slip high traction differential** is standard on all units for best traction of rear tires.
- **Optional heavy-duty front-mounted blade** with reversible cutting edge is available to allow backfilling and leveling during compaction.
- **ROPS (Roll Over Protective Structure)** standard on all units. Enclosed cabs with EROPS rating available as an option.

- **Optional Cat Compaction Control** featuring exclusive Machine Drive Power (MDP) or CMV (accelerometer-based) measurement scalable to include GNSS mapping and recording.
- **Adjustable jaw-type cleaner bar** keeps drums clean between pads during forward and reverse movement.

Double Drum and Combi

- **Vibration automatically ceases before machine comes to a stop** to help produce a smooth, flawless mat surface.
- **Close side clearances** allow compactors to work close to curbs, walls and other obstructions.
- **Large, rust-proof water tanks and pressure spray system** provide hours of reliable operation between fill-ups.
- **Emulsion system** available for combi compactor rear tires to prevent materials sticking to tires.
- **ROPS (Roll Over Protective Structure)** available on all models. Enclosed cabs with EROPS rating available on some models.
- **Optional Cat Compaction Control** featuring GNSS mapping of pass count and mat surface temperature.

Pneumatic Tire Compactor Features:

- **All wheel oscillation.** Front and rear tires provide even wheel loads regardless of evenness underfoot. PF models have front oscillation only.
- **High drive propel system.** Completely hydrostatic with drive motors and brakes located in mainframe away from contamination and damage.
- **Ballast compartments** are easily accessible for quick loading and are located to provide balanced wheel/weight ratio.
- **Single-lever hand control** of forward and reverse movement makes smooth rolling easy.
- **Optional Cat Compaction Control** featuring GNSS mapping of pass count and mat surface temperature.

NOTE: All models and options are not available in all markets.

MODEL	CS34		CS423E		CS44	
Gross Power	55 kW	74 hp	62 kW	83 hp	75 kW	100 hp
Rated Engine RPM	2200		2200		2200	
No. Cylinders	4		4		4	
Displacement	3.4 L	207 in ³	4.4 L	269 in ³	4.4 L	269 in ³
Engine Model	C3.4B		3054C		C4.4 ACERT	
Emission Standards	Tier 4 Final/Stage IV		Tier 2/Stage II equivalent		Tier 3/Stage IIIA equivalent	
Speeds	1 forward/1 reverse		2 forward/2 reverse		2 forward/2 reverse	
Max. Speed (For./Rev.)	8.9 km/h	5.5 mph	11.5 km/h	7.1 mph	12.3 km/h	7.6 mph
Approximate Operating Weight	4445 kg	9799 lb	6745 kg	14,875 lb	6900 kg	15,212 lb
Drive	Drum/Rear Wheel		Drum/Rear Wheel		Drum/Rear Wheel	
Steering:						
Inside Radius	2625 mm	8'7"	3050 mm	10'0"	3080 mm	10'1"
Outside Radius	3896 mm	12'9"	4730 mm	15'6"	4756 mm	15'7"
Steering Angle	±38°		±37°		±37°	
Vibratory System:						
Ecc. Weight Drive	Hydraulic		Hydraulic		Hydraulic	
Frequency ³	35 Hz	2100 vpm	31.9 Hz	1915 vpm	31.9 Hz	1914 vpm
Amplitude:	1		2		2	
High Amplitude	1.3 mm	0.05"	1.67 mm	0.066"	1.67 mm	0.066"
Low Amplitude	1.3 mm	0.05"	0.84 mm	0.033"	0.84 mm	0.033"
Centrifugal Force:						
Maximum	66.8 kN	15,000 lb	133.5 kN	30,000 lb	133.5 kN	30,000 lb
Minimum	66.8 kN	15,000 lb	66.8 kN	15,000 lb	66.8 kN	15,000 lb
General Dimensions:						
Overall Width with Blade	—		—		2120 mm	6'11"
Overall Width without Blade	1393 mm	4'6"	1800 mm	5'11"	1800 mm	5'11"
Drum Width	1270 mm	4'2"	1680 mm	5'6"	1680 mm	5'6"
Drum Diameter	1016 mm	3'4"	1220 mm	4'0"	1220 mm	4'0"
Tires	11.2 × 24 — 6 ply		14.9 × 24 — 6 ply		14.9 × 24 — 6 ply	
Overall Height	2514 mm	8'2"	2930 mm	9'7"	2930 mm	9'7"
Wheel to Drum	2240 mm	7'4"	2600 mm	8'6"	2600 mm	8'6"
Overall Length	4150 mm	13'7"	4960 mm	16'3"	5080 mm	16'8"
Curb Clearance	335 mm	13.2"	375 mm	14.8"	380 mm	14.9"
Service Refill Capacities:						
Fuel Tank	113 L	30 U.S. gal	153 L	40.4 U.S. gal	180 L	47.5 U.S. gal
Crankcase	8 L	2.1 U.S. gal	6.8 L	1.8 U.S. gal	8.5 L	2.2 U.S. gal
Hydraulic Fluid	40 L	10.6 U.S. gal	60 L	16 U.S. gal	80 L	21.1 U.S. gal

MODEL	CS44B		CS533E		CS54B*	
Gross Power	75 kW	100.6 hp	97 kW	130 hp	98 kW	131 hp
Rated Engine RPM	2200		2200		2200	
No. Cylinders	4		4		4	
Displacement	3.4 L	207 in³	4.4 L	269 in³	4.4 L	268 in³
Engine Model	C3.4B		C4.4 ACERT		C4.4 ACERT	
Emission Standards	Tier 4 Final/Stage IV		Tier 2/Stage II equivalent		Tier 4 Final/Stage IV	
Speeds	2 forward/2 reverse		2 forward/2 reverse		2 forward/2 reverse	
Max. Speed (For./Rev.)	12.3 km/h	7.6 mph	12 km/h	7.5 mph	11.1 km/h	6.8 mph
Approximate Operating Weight	6943 kg	15,307 lb	10 485 kg	23,120 lb	10 555 kg	23,265 lb
Drive	Drum/Rear Wheel		Drum/Rear Wheel		Drum/Rear Wheel	
Steering:						
Inside Radius	3050 mm	10'0"	3680 mm	12'1"	3680 mm	12'1"
Outside Radius	4730 mm	15'6"	5810 mm	19'1"	5810 mm	19'1"
Steering Angle	±37°		±34°		±34°	
Vibratory System:						
Ecc. Weight Drive	Hydraulic		Hydraulic		Hydraulic	
Frequency ³	31.9 Hz	1914 vpm	31 Hz	1860 vpm	30.5 Hz	1830 vpm
Amplitude:	2		2		2	
High Amplitude	1.59 mm	0.063"	1.80 mm	0.071"	1.90 mm	0.075"
Low Amplitude	0.80 mm	0.032"	0.85 mm	0.033"	0.95 mm	0.037"
Centrifugal Force:						
Maximum	133 kN	29,900 lb	234 kN	52,600 lb	234 kN	52,600 lb
Minimum	67 kN	15,000 lb	133 kN	30,000 lb	133 kN	29,900 lb
General Dimensions:						
Overall Width with Blade	2120 mm	7'0"	—	—	—	—
Overall Width without Blade	1800 mm	5'11"	2286 mm	7'6"	2300 mm	7'7"
Drum Width	1676 mm	5'6"	2130 mm	7'0"	2134 mm	7'0"
Drum Diameter	1221 mm	4'0"	1534 mm	5'0"	1534 mm	5'0"
Tires	14.9 × 24 — 6 ply		23.1 × 26 — 8 ply floatation		23.1 × 26 — 8 ply floatation	
Overall Height	2850 mm	9'4"	3070 mm	10'1"	3110 mm	10'3"
Wheel to Drum	2600 mm	8'6"	2900 mm	9'6"	2900 mm	9'7"
Overall Length	5090 mm	16'9"	5510 mm	18'1"	5850 mm	19'2"
Curb Clearance	369 mm	14.5"	521 mm	20.5"	543 mm	21.4"
Service Refill Capacities:						
Fuel Tank	150 L	39.6 U.S. gal	180 L	47.5 U.S. gal	242 L	64 U.S. gal
Diesel Exhaust Fluid Refill Capacity	18.9 L	5 U.S. gal	—	—	15 L	4 U.S. gal
Crankcase	9 L	2.4 U.S. gal	9 L	2.4 U.S. gal	8.8 L	2.3 U.S. gal
Hydraulic Fluid	26 L	6.9 U.S. gal	60 L	16 U.S. gal	50 L	13.2 U.S. gal

*Some markets feature a Cat C4.4 ACERT engine that meets U.S. EPA Tier 3/EU Stage IIIA equivalent emission standards.

MODEL	CS56B*		CS64B*		CS66B	
Gross Power	117 kW	157 hp	98 kW	131 hp	117 kW	157 hp
Rated Engine RPM	2200		2200		2200	
No. Cylinders	4		4		4	
Displacement	4.4 L	268 in ³	4.4 L	268 in ³	4.4 L	268 in ³
Engine Model	C4.4 ACERT		C4.4 ACERT		C4.4 ACERT	
Emission Standards	Tier 4 Final/Stage IV		Tier 4 Final/Stage IV		Tier 4 Final/Stage IV	
Speeds	2 forward/2 reverse		2 forward/2 reverse		2 forward/2 reverse	
Max. Speed (For./Rev.)	11.1 km/h	6.8 mph	11 km/h	6.8 mph	11.4 km/h	7 mph
Approximate Operating Weight	10 555 kg	23,265 lb	12 055 kg	26,569 lb	12 360 kg	27,245 lb
Drive	Drum/Rear Wheel		Drum/Rear Wheel		Drum/Rear Wheel	
Steering:						
Inside Radius	3680 mm	12'1"	3680 mm	12'1"	3680 mm	12'1"
Outside Radius	5810 mm	19'1"	5810 mm	19'1"	5810 mm	19'1"
Steering Angle	±34°		±34°		±34°	
Vibratory System:						
Ecc. Weight Drive	Hydraulic		Hydraulic		Hydraulic	
Frequency ³	30.5 Hz	1830 vpm	30.5 Hz	1830 vpm	30.5 Hz	1830 vpm
Amplitude:	2		2		2	
High Amplitude	2.10 mm	0.083"	1.90 mm	0.075"	2.10 mm	0.083"
Low Amplitude	0.98 mm	0.039"	0.95 mm	0.037"	0.98 mm	0.039"
Centrifugal Force:						
Maximum	301 kN	67,600 lb	234 kN	52,600 lb	301 kN	67,600 lb
Minimum	141 kN	31,670 lb	133 kN	29,900 lb	141 kN	31,670 lb
General Dimensions:						
Overall Width with Blade	2500 mm	8'3"	—	—	2500 mm	8'3"
Overall Width without Blade	2300 mm	7'7"	2330 mm	7'8"	2330 mm	7'8"
Drum Width	2134 mm	7'0"	2134 mm	7'0"	2134 mm	7'0"
Drum Diameter	1534 mm	5'0"	1534 mm	5'0"	1534 mm	5'0"
Tires	23.1 × 26 — 8 ply floatation		23.1 × 26 — 8 ply floatation		23.1 × 26 — 8 ply floatation	
Overall Height	3110 mm	10'3"	3110 mm	10'3"	3110 mm	10'3"
Wheel to Drum	2900 mm	9'7"	2900 mm	9'7"	2900 mm	9'7"
Overall Length	5860 mm	19'3"	5850 mm	19'2"	5860 mm	19'3"
Curb Clearance	494 mm	19.4"	543 mm	21.4"	494 mm	19.4"
Service Refill Capacities:						
Fuel Tank	242 L	64 U.S. gal	242 L	64 U.S. gal	242 L	64 U.S. gal
Diesel Exhaust Fluid Refill Capacity	15 L	4 U.S. gal	15 L	4 U.S. gal	15 L	4 U.S. gal
Crankcase	11.6 L	3.1 U.S. gal	8.8 L	2.3 U.S. gal	11.6 L	3.1 U.S. gal
Hydraulic Fluid	50 L	13.2 U.S. gal	50 L	13.2 U.S. gal	50 L	13.2 U.S. gal

*Some markets feature a Cat C4.4 ACERT engine that meets U.S. EPA Tier 3/EU Stage IIIA equivalent emission standards.

MODEL	CS68B*		CS74B**		CS76B	
Gross Power	117 kW	157 hp	129.5 kW	173.7 hp	129.5 kW	173.7 hp
Rated Engine RPM	2200		2200		2200	
No. Cylinders	4		4		4	
Displacement	4.4 L	268 in ³	4.4 L	268 in ³	4.4 L	268 in ³
Engine Model	C4.4 ACERT		C4.4 ACERT		C4.4 ACERT	
Emission Standards	Tier 4 Final/Stage IV		Tier 4 Final/Stage IV		Tier 4 Final/Stage IV	
Speeds	2 forward/2 reverse		2 forward/2 reverse		2 forward/2 reverse	
Max. Speed (For./Rev.)	11.4 km/h	7 mph	11.4 km/h	7 mph	11.4 km/h	7 mph
Approximate Operating Weight	14 325 kg	31,572 lb	16 000 kg	35,264 lb	17 445 kg	38,450 lb
Drive	Drum/Rear Wheel		Drum/Rear Wheel		Drum/Rear Wheel	
Steering:						
Inside Radius	3680 mm	12'1"	3680 mm	12'1"	3680 mm	12'1"
Outside Radius	5810 mm	19'1"	5810 mm	19'1"	5810 mm	19'1"
Steering Angle	±34°		±34°		±34°	
Vibratory System:						
Ecc. Weight Drive	Hydraulic		Hydraulic		Hydraulic	
Frequency ³	30.5 Hz	1830 vpm	30.5 Hz	1830 vpm	30.5 Hz	1830 vpm
Amplitude:	2		2		2	
High Amplitude	2.10 mm	0.083"	2.10 mm	0.083"	2.10 mm	0.083"
Low Amplitude	0.98 mm	0.039"	0.98 mm	0.039"	0.98 mm	0.039"
Centrifugal Force:						
Maximum	301 kN	67,600 lb	332 kN	74,600 lb	332 kN	74,600 lb
Minimum	141 kN	31,670 lb	166 kN	37,300 lb	166 kN	37,300 lb
General Dimensions:						
Overall Width with Blade	2500 mm	8'3"	2500 mm	8'3"	—	—
Overall Width without Blade	2330 mm	7'8"	2330 mm	7'8"	2360 mm	7'9"
Drum Width	2134 mm	7'0"	2134 mm	7'0"	2134 mm	7'0"
Drum Diameter	1534 mm	5'0"	1534 mm	5'0"	1534 mm	5'0"
Tires	23.1 × 26 — 8 ply floatation		23.1 × 26 — 8 ply floatation		23.1 × 26 — 12 ply floatation	
Overall Height	3110 mm	10'3"	3110 mm	10'3"	3110 mm	10'3"
Wheel to Drum	2900 mm	9'7"	2900 mm	9'7"	2900 mm	9'7"
Overall Length	6050 mm	19'10"	6050 mm	19'10"	6130 mm	20'1"
Curb Clearance	489 mm	19.3"	489 mm	19.3"	528 mm	20.8"
Service Refill Capacities:						
Fuel Tank	242 L	64 U.S. gal	332 L	88 U.S. gal	332 L	88 U.S. gal
Diesel Exhaust Fluid Refill Capacity	15 L	4 U.S. gal	15 L	4 U.S. gal	15 L	4 U.S. gal
Crankcase	11.6 L	3.1 U.S. gal	11.6 L	3.1 U.S. gal	11.6 L	3.1 U.S. gal
Hydraulic Fluid	50 L	13.2 U.S. gal	50 L	13.2 U.S. gal	50 L	13.2 U.S. gal

*Some markets feature a Cat C4.4 ACERT engine that meets U.S. EPA Tier 3/EU Stage IIIA equivalent emission standards.

**Some markets feature a Cat C6.6 ACERT engine that meets U.S. EPA Tier 3/EU Stage IIIA equivalent emission standards.

MODEL	CS78B*		CS79B	
Gross Power	129.5 kW	173.7 hp	129.5 kW	173.7 hp
Rated Engine RPM	2200		2200	
No. Cylinders	4		6	
Displacement	4.4 L	268 in ³	6.6 L	403 in ³
Engine Model	C4.4 ACERT		C6.6 ACERT	
Emission Standards	Tier 4 Final/Stage IV		Tier 3/Stage IIIA equivalent	
Speeds	2 forward/2 reverse		2 forward/2 reverse	
Max. Speed (For./Rev.)	11.4 km/h	7 mph	11.4 km/h	7 mph
Approximate Operating Weight	18 700 kg	41,214 lb	20 200 kg	44,577 lb
Drive	Drum/Rear Wheel		Drum/Rear Wheel	
Steering:				
Inside Radius	3680 mm	12'1"	3680 mm	12'1"
Outside Radius	5810 mm	19'1"	5810 mm	19'1"
Steering Angle	±34°		± 34°	
Vibratory System:				
Ecc. Weight Drive	Hydraulic		Hydraulic	
Frequency ³	28 Hz	1680 vpm	28 Hz	1680 vpm
Amplitude:	2		2	
High Amplitude	2.10 mm	0.083"	2.10 mm	0.083"
Low Amplitude	0.98 mm	0.039"	0.98 mm	0.039"
Centrifugal Force:				
Maximum	332 kN	74,600 lb	332 kN	74,600 lb
Minimum	166 kN	37,300 lb	166 kN	37,300 lb
General Dimensions:				
Overall Width without Blade	2460 mm	8'1"	2460 mm	8'1"
Drum Width	2134 mm	7'0"	2134 mm	7'0"
Drum Diameter	1534 mm	5'0"	1534 mm	5'0"
Tires	23.1 × 26 — 12 ply floatation		23.1 × 26 — 12 ply floatation	
Overall Height	3110 mm	10'3"	3110 mm	10'3"
Wheel to Drum	2900 mm	9'7"	2900 mm	9'7"
Overall Length	6130 mm	20'1"	6130 mm	20'1"
Curb Clearance	535 mm	21.1"	535 mm	21.1"
Service Refill Capacities:				
Fuel Tank	332 L	88 U.S. gal	332 L	88 U.S. gal
Diesel Exhaust Fluid Refill Capacity	15 L	4 U.S. gal	—	—
Crankcase	11.6 L	3.1 U.S. gal	17.4 L	4.6 U.S. gal
Hydraulic Fluid	50 L	13.2 U.S. gal	50 L	13.2 U.S. gal

*Need footnote copy.

MODEL	CP34		CP44		CP44B	
Gross Power	55 kW	74 hp	75 kW	100 hp	75 kW	100.6 hp
Rated Engine RPM	2200		2200		2200	
No. Cylinders	4		4		4	
Displacement	3.4 L	207 in³	4.4 L	269 in³	3.4 L	207 in³
Engine Model	C3.4B		C4.4 ACERT		Cat C3.4B	
Emission Standards	Tier 4 Final/Stage IV		Tier 3/Stage IIIA equivalent		Tier 4 Final/Stage IV	
Speeds	1 forward/1 reverse		2 forward/2 reverse		2 forward/2 reverse	
Max. Speed (For./Rev.)	8.9 km/h	5.5 mph	12.3 km/h	7.6 mph	12.3 km/h	7.6 mph
Approximate Operating Weight	4995 kg	11,000 lb	6900 kg	15,212 lb	7228 kg	15,935 lb
Drive	Drum/Rear Wheel		Drum/Rear Wheel		Drum/Rear Wheel	
Steering:						
Inside Radius	2625 mm	8'7"	3080 mm	10'1"	3050 mm	10'0"
Outside Radius	3896 mm	12'9"	4756 mm	15'7"	4730 mm	15'6"
Steering Angle	±38°		±37°		±37°	
Vibratory System:						
Ecc. Weight Drive	Hydraulic		Hydraulic		Hydraulic	
Frequency ³	35 Hz	2100 vpm	31.9 Hz	1914 vpm	31.9 Hz	1914 vpm
Amplitude:	1		2		2	
High Amplitude	1.3 mm	0.05"	1.67 mm	0.066"	1.59 mm	0.063"
Low Amplitude	1.3 mm	0.05"	0.84 mm	0.033"	0.80 mm	0.031"
Centrifugal Force:						
Maximum	66.8 kN	15,000 lb	133.5 kN	30,000 lb	133 kN	29,900 lb
Minimum	66.8 kN	15,000 lb	66.8 kN	15,000 lb	67 kN	15,000 lb
General Dimensions:						
Overall Width with Blade	1575 mm	5'2"	2120 mm	6'11"	2120 mm	7'0"
Overall Width without Blade	1393 mm	4'6"	1800 mm	5'11"	1800 mm	5'11"
Drum Width	1270 mm	4'2"	1680 mm	5'6"	1676 mm	5'6"
Drum Diameter over Pads	1016 mm	3'4"	1225 mm	4'0"	1225 mm	4'0"
Tires	11.2 × 24 — 6 ply traction		14.9 × 24 — 8 ply traction		14.9 × 24 — 6 ply traction	
Overall Height	2514 mm	8'2"	2930 mm	9'7"	2850 mm	9'4"
Wheel to Drum	2240 mm	7'4"	2600 mm	8'6"	2600 mm	8'6"
Overall Length	4580 mm	15'0"	5080 mm	16'8"	5090 mm	16'9"
Curb Clearance	335 mm	13.2"	380 mm	14.9"	371 mm	14.6"
Service Refill Capacities:						
Fuel Tank	113 L	30 U.S. gal	180 L	47.5 U.S. gal	150 L	39.6 U.S. gal
Diesel Exhaust Fluid Refill Capacity	—		—		18.9 L	5 U.S. gal
Crankcase	8 L	2.1 U.S. gal	8.5 L	2.2 U.S. gal	9 L	2.4 U.S. gal
Hydraulic Fluid	40 L	10.6 U.S. gal	80 L	21.1 U.S. gal	26 L	6.9 U.S. gal

MODEL	CP533E		CP54B*		CP56B*	
Gross Power	97 kW	130 hp	98 kW	131 hp	117 kW	157 hp
Rated Engine RPM	2200		2200		2200	
No. Cylinders	4		4		4	
Displacement	4.4 L	268 in ³	4.4 L	268 in ³	4.4 L	268 in ³
Engine Model	C4.4 ACERT		C4.4 ACERT		C4.4 ACERT	
Emission Standards	Tier 2/Stage II equivalent		Tier 4 Final/Stage IV		Tier 4 Final/Stage IV	
Speeds	2 forward/2 reverse		2 forward/2 reverse		2 forward/2 reverse	
Max. Speed (For./Rev.)	12 km/h	7.5 mph	11 km/h	6.8 mph	11.4 km/h	7 mph
Approximate Operating Weight	11 320 kg	24,960 lb	10 935 kg	24,096 lb	11 665 kg	25,707 lb
Drive	Drum/Rear Wheel		Drum/Rear Wheel		Drum/Rear Wheel	
Steering:						
Inside Radius	3680 mm	12'1"	3680 mm	12'1"	3680 mm	12'1"
Outside Radius	5810 mm	19'1"	5810 mm	19'1"	5810 mm	19'1"
Steering Angle	±34°		±34°		±34°	
Vibratory System:						
Ecc. Weight Drive	Hydraulic		Hydraulic		Hydraulic	
Frequency ³	31.9 Hz	1914 vpm	30.5 Hz	1830 vpm	30.5 Hz	1830 vpm
Amplitude:	2		2		2	
High Amplitude	1.70 mm	0.067"	1.90 mm	0.075"	2.10 mm	0.083"
Low Amplitude	0.85 mm	0.033"	0.88 mm	0.035"	0.98 mm	0.039"
Centrifugal Force:						
Maximum	266 kN	60,000 lb	266 kN	59,800 lb	301 kN	67,600 lb
Minimum	133.5 kN	30,000 lb	133 kN	29,900 lb	141 kN	31,670 lb
General Dimensions:						
Overall Width with Blade	—		—		2500 mm	8'3"
Overall Width without Blade	2286 mm	7'6"	2300 mm	7'7"	2300 mm	7'7"
Drum Width	2130 mm	7'0"	2134 mm	7'0"	2134 mm	7'0"
Drum Diameter over Pads	1549 mm	5'1"	1534 mm	5'0"	1549 mm	5'1"
Tires	23.1 × 26 — 8 ply traction		23.1 × 26 — 8 ply traction		23.1 × 26 — 8 ply traction	
Overall Height	3070 mm	10'1"	3110 mm	10'3"	3110 mm	10'3"
Wheel to Drum	2900 mm	9'6"	2900 mm	9'7"	2900 mm	9'7"
Overall Length	5510 mm	18'1"	5850 mm	19'2"	5860 mm	19'3"
Curb Clearance	521 mm	20.5"	551 mm	21.7"	506 mm	19.9"
Service Refill Capacities:						
Fuel Tank	180 L	475 U.S. gal	242 L	64 U.S. gal	242 L	64 U.S. gal
Diesel Exhaust Fluid Refill Capacity	—		15 L	4 U.S. gal	15 L	4 U.S. gal
Crankcase	9 L	2.4 U.S. gal	8.8 L	2.3 U.S. gal	11.6 L	3.1 U.S. gal
Hydraulic Fluid	60 L	16 U.S. gal	50 L	13.2 U.S. gal	50 L	13.2 U.S. gal

*Some markets feature a Cat C4.4 ACERT engine that meets U.S. EPA Tier 3/EU Stage IIIA equivalent emission standards.

MODEL	CP68B*		CP74B**	
Gross Power	117 kW	157 hp	129.5 kW	173.7 hp
Rated Engine RPM	2200		2200	
No. Cylinders	4		4	
Displacement	4.4 L	268 in ³	4.4 L	268 in ³
Engine Model	C4.4 ACERT		C4.4 ACERT	
Emission Standards	Tier 4 Final/Stage IV		Tier 4 Final/Stage IV	
Speeds	2 forward/2 reverse		2 forward/2 reverse	
Max. Speed (For./Rev.)	11.4 km/h	7 mph	11.4 km/h	7 mph
Approximate Operating Weight	14 685 kg	32,370 lb	16 355 kg	36,048 lb
Drive	Drum/Rear Wheel		Drum/Rear Wheel	
Steering:				
Inside Radius	3680 mm	12'1"	3680 mm	12'1"
Outside Radius	5810 mm	19'1"	5810 mm	19'1"
Steering Angle	±34°		±34°	
Vibratory System:				
Ecc. Weight Drive	Hydraulic		Hydraulic	
Frequency ³	30.5 Hz	1830 vpm	28 Hz	1680 vpm
Amplitude:	2		2	
High Amplitude	2.10 mm	0.083"	2.10 mm	0.083"
Low Amplitude	0.98 mm	0.039"	0.98 mm	0.039"
Centrifugal Force:				
Maximum	301 kN	67,600 lb	332 kN	74,600 lb
Minimum	141 kN	31,670 lb	166 kN	37,300 lb
General Dimensions:				
Overall Width with Blade	2500 mm	8'3"	2500 mm	8'3"
Overall Width without Blade	2330 mm	7'8"	2330 mm	7'8"
Drum Width	2134 mm	7'0"	2134 mm	7'0"
Drum Diameter over Pads	1549 mm	5'1"	1549 mm	5'1"
Tires	23.1 × 26 — 8 ply traction		23.1 × 26 — 12 ply traction	
Overall Height	3110 mm	10'3"	3110 mm	10'3"
Wheel to Drum	2900 mm	9'7"	2900 mm	9'7"
Overall Length	6050 mm	19'10"	6050 mm	19'10"
Curb Clearance	497 mm	19.6"	497 mm	19.6"
Service Refill Capacities:				
Fuel Tank	242 L	64 U.S. gal	332 L	88 U.S. gal
Diesel Exhaust Fluid Refill Capacity	15 L	4 U.S. gal	15 L	4 U.S. gal
Crankcase	11.6 L	3.1 U.S. gal	11.6 L	3.1 U.S. gal
Hydraulic Fluid	50 L	13.2 U.S. gal	50 L	13.2 U.S. gal

*Some markets feature a Cat C4.4 ACERT engine that meets U.S. EPA Tier 3/EU Stage IIIA equivalent emission standards.

**Some markets feature a Cat C6.6 ACERT engine that meets U.S. EPA Tier 3/EU Stage IIIA equivalent emission standards.

MODEL	CB14B		CB14B XW		CB22B	
Gross Power	16.8 kW	22.5 hp	16.8 kW	22.5 hp	27 kW	36.2 hp
Rated Engine RPM	2850		2850		2800	
No. Cylinders	3		3		3	
Displacement	1028 cm ³	62.7 in ³	1028 cm ³	62.7 in ³	1.5 L	92 in ³
Engine Model	KDW1003		KDW1003		C1.5	
Emission Standards	Tier 4 Final/Stage IV		Tier 4 Final/Stage IV		Tier 4 Final/Stage IV	
Speeds	Variable		Variable		—	
Max. Speed (For./Rev.)	9.3 km/h	5.8 mph	9.3 km/h	5.8 mph	12 km/h	7.5 mph
Working Speed	0-9.3 km/h	0-5.8 mph	0-9.3 km/h	0-5.8 mph	—	
Operating Weight	1485 kg	3274 lb	1520 kg	3351 lb	2558 kg	5629 lb
Drive	—		—		Hydraulic	
Steering:						
Inside Radius	2.02 m	6.6'	1.97 m	6.4'	2670 mm	105"
Outside Radius	2.9 m	9.6'	3.0 m	9.8'	3470 mm	137"
Steering Angle	±32°		±32°		±32°	
Vibratory System:						
Ecc. Weight Drive	Hydraulic		Hydraulic		Hydraulic	
Frequency (Max.)	70 Hz	4200 vpm	65 Hz	3900 vpm	63 Hz	3780 vpm
Amplitude:	—		—		1	
High Amplitude	0.92 mm	0.036"	0.92 mm	0.036"	0.53 mm	0.021"
Centrifugal Force:						
High Amplitude	15 kN	3400 lb	15 kN	3400 lb	28.8 kN	6475 lb
General Dimensions:						
Overall Width	1000 mm	39"	1102 mm	43"	1112 mm	44"
Drum Width	900 mm	35"	1000 mm	39"	1000 mm	39"
Drum Diameter	560 mm	22"	560 mm	22"	720 mm	28"
Overall Height (ROPS)	2545 mm	100"	2545 mm	100"	2700 mm	106"
Wheelbase	1380 mm	54"	1380 mm	54"	1800 mm	71"
Overall Length	1950 mm	77"	1950 mm	77"	2575 mm	101"
Curb Clearance	400 mm	16"	400 mm	16"	620 mm	24"
Ground Clearance	220 mm	9"	220 mm	9"	285 mm	11"
Service Refill Capacities:						
Fuel Tank	23 L	6.1 U.S. gal	23 L	6.1 U.S. gal	63.5 L	16.7 U.S. gal
Crankcase	—		—		6.0 L	1.6 U.S. gal
Hydraulic Tank	—		—		18.9 L	5 U.S. gal
Sprinkler Water	100 L	26.4 U.S. gal	100 L	26.4 U.S. gal	235 L	62.1 U.S. gal

MODEL	CB24B ¹		CB24B XT		CC24B ²		CB32B ¹	
Gross Power	27 kW	36.2 hp	27 kW	36.2 hp	27 kW	36.2 hp	27 kW	36.2 hp
Rated Engine RPM	2800		2800		2800		2800	
No. Cylinders	3		3		3		3	
Displacement	1.5 L	92 in³	1.5 L	92 in³	1.5 L	92 in³	1.5 L	92 in³
Engine Model	C1.5		C1.5		C1.5		C1.5	
Emission Standards	Tier 4 Final/Stage IV		Tier 4 Final/Stage IV		Tier 4 Final/Stage IV		Tier 4 Final/Stage IV	
Max. Speed (For./Rev.)	12 km/h	7.5 mph	12 km/h	7.5 mph	12 km/h	7.5 mph	12 km/h	7.5 mph
Operating Weight	2723 kg	6003 lb	3123 kg	6885 lb	2554 kg	6438 lb	3321 kg	7320 lb
Drive	Hydraulic		Hydraulic		Hydraulic		Hydraulic	
Steering:								
Inside Radius	2470 mm	97"	2470 mm	97"	2475 mm	97"	2370 mm	93"
Outside Radius	3670 mm	145"	3670 mm	145"	3675 mm	145"	3770 mm	148"
Steering Angle	±32°		±32°		±32°		±32°	
Vibratory System:								
Ecc. Weight Drive	Hydraulic		Hydraulic		Hydraulic		Hydraulic	
Frequency (Max.)	63 Hz	3780 vpm	63 Hz	3780 vpm	63 Hz	3780 vpm	63 Hz	3780 vpm
Amplitude:	1		1		1		1	
High Amplitude	0.53 mm	0.021"	0.53 mm	0.021"	0.53 mm	0.021"	0.53 mm	0.021"
Centrifugal Force:								
High Amplitude	32.8 kN	7374 lb	34.7 kN	7801 lb	34.7 kN	7801 lb	37.1 kN	8340 lb
General Dimensions:								
Overall Width	1312 mm	52"	1312 mm	52"	1312 mm	52"	1312 mm	52"
Drum Width	1200 mm	47"	1200 mm	47"	1200 mm	47"	1300 mm	51"
Drum Diameter	720 mm	28"	720 mm	28"	720 mm	28"	720 mm	28"
Tires	—		—		6-ply		—	
Overall Height (ROPS)	2700 mm	106"	2700 mm	106"	2700 mm	106"	2700 mm	106"
Wheelbase	1800 mm	71"	1800 mm	71"	1800 mm	71"	1800 mm	71"
Overall Length	2575 mm	101"	2575 mm	101"	2575 mm	101"	2575 mm	101"
Curb Clearance	620 mm	24"	620 mm	24"	620 mm	24"	620 mm	24"
Ground Clearance	285 mm	11"	285 mm	11"	285 mm	11"	285 mm	11"
Service Refill Capacities:								
Fuel Tank	63.5 L	16.7 U.S. gal	63.5 L	16.7 U.S. gal	63.5 L	16.7 U.S. gal	63.5 L	16.7 U.S. gal
Crankcase	6.0 L	1.6 U.S. gal	6.0 L	1.6 U.S. gal	6.0 L	1.6 U.S. gal	6.0 L	1.6 U.S. gal
Hydraulic Tank	18.9 L	5 U.S. gal	18.9 L	5 U.S. gal	18.9 L	5 U.S. gal	18.9 L	5 U.S. gal
Sprinkler Water	235 L	62.1 U.S. gal	235 L	62.1 U.S. gal	235 L	62.1 U.S. gal	235 L	62.1 U.S. gal

¹400 kg (882 lb) ballast weight kit available.

²Combi Asphalt Compactor with steel drum on front and rubber tires on rear.

MODEL	CB34B ¹		CB34B XW		CC34B ²	
Gross Power	36.4 kW	48.8 hp	36.4 kW	48.8 hp	36.4 kW	48.8 hp
Rated Engine RPM	2400		2400		2400	
No. Cylinders	4		4		4	
Displacement	2.2 L	134 in³	2.2 L	134 in³	2.2 L	134 in³
Engine Model	C2.2		C2.2		C2.2	
Emission Standards	Tier 4 Final/Stage IV		Tier 4 Final/Stage IV		Tier 4 Final/Stage IV	
Max. Speed (For./Rev.)	12 km/h	7.5 mph	12 km/h	7.5 mph	12 km/h	7.5 mph
Operating Weight	3699 kg	8155 lb	3803 kg	8385 lb	3378 kg	7446 lb
Shipping Weight	3466 kg	7641 lb	3570 kg	7871 lb	3145 kg	6932 lb
Drive	Hydraulic		Hydraulic		Hydraulic	
Steering:						
Inside Radius	2932 mm	115"	2897 mm	114"	2937 mm	116"
Outside Radius	4232 mm	167"	4297 mm	169"	4237 mm	169"
Steering Angle	±32°		±32°		±32°	
Vibratory System:						
Ecc. Weight Drive	Hydraulic		Hydraulic		Hydraulic	
Frequency	55 Hz	3300 vpm	55 Hz	3300 vpm	55 Hz	3300 vpm
Amplitude:	1		1		1	
High Amplitude	0.50 mm	0.020"	0.50 mm	0.020"	0.50 mm	0.020"
Centrifugal Force:						
High Amplitude	31.6 kN	7104 lb	33.5 kN	7531 lb	31.6 kN	7104 lb
Low Amplitude	24.1 kN	5418 lb	25.5 kN	5733 lb	24.1 kN	5418 lb
General Dimensions:						
Overall Width	1400 mm	55"	1500 mm	59"	1400 mm	55"
Drum Width	1300 mm	51"	1400 mm	55"	1300 mm	51"
Drum Diameter	800 mm	32"	800 mm	32"	800 mm	32"
Tires	—		—		6-ply	
Overall Height (ROPS)	2765 mm	109"	2765 mm	109"	2765 mm	109"
Wheelbase	2050 mm	81"	2050 mm	81"	2050 mm	81"
Overall Length	2859 mm	113"	2859 mm	113"	2859 mm	113"
Curb Clearance	625 mm	25"	625 mm	25"	625 mm	25"
Ground Clearance	284 mm	11"	284 mm	11"	284 mm	11"
Service Refill Capacities:						
Fuel Tank	90.7 L	24 U.S. gal	90.7 L	24 U.S. gal	90.7 L	24 U.S. gal
Crankcase	10.6 L	2.8 U.S. gal	10.6 L	2.8 U.S. gal	10.6 L	2.8 U.S. gal
Hydraulic Tank	18.9 L	5 U.S. gal	18.9 L	5 U.S. gal	18.9 L	5 U.S. gal
Sprinkler Water	308 L	81 U.S. gal	308 L	81 U.S. gal	308 L	81 U.S. gal

¹400 kg (882 lb) ballast weight kit available.

²Combi Asphalt Compactor with steel drum on front and rubber tires on rear.

MODEL	CB44B ^{1,3}		CD44B ^{2,4}		CB54B ^{1,3}	
Gross Power	75 kW	100 hp	75 kW	100 hp	98 kW	131 hp
Rated Engine RPM	2200 rpm		2200 rpm		2200 rpm	
No. Cylinders	4		4		4	
Displacement	3.4 L	207.5 in ³	3.4 L	207.5 in ³	4.4 L	269 in ³
Engine Model	C3.4B ACERT		C3.4B ACERT		C4.4 ACERT	
Emission Standards	Tier 4 Final/Stage IV		Tier 4 Final/Stage IV		Tier 4 Final/Stage IV	
Speeds	2 forward/2 reverse		2 forward/2 reverse		2 forward/2 reverse	
Max. Speed (For./Rev.)	12 km/h	7.5 mph	12 km/h	7.5 mph	12 km/h	7.5 mph
Working Speed	0-12 km/h	0-7.5 mph	0-12 km/h	0-7.5 mph	0-12 km/h	0-7.5 mph
Approximate Operating Weight	7990 kg	17,615 lb	8390 kg	18,497 lb	9500 kg	20,944 lb
Drive	Hydraulic		Hydraulic		Hydraulic	
Steering:						
Inside Radius	4351 mm	14'3"	2942 mm	9'9"	4250 mm	13'11"
Outside Radius	5851 mm	19'2"	4441 mm	14'8"	5950 mm	19'6"
Steering Angle	±36°		±25°		±36°	
Vibratory System:						
Ecc. Weight Drive	Hydraulic		Hydraulic		Hydraulic	
Frequency	53.3 Hz	3200 vpm	42/53.3 Hz	2520/ 3200 vpm	43 Hz	2580 vpm
Amplitude:						
High Amplitude	0.64 mm	0.025"	0.62 mm	0.024"	1.06 mm	0.042"
Low Amplitude	0.25 mm	0.010"	0.31 mm	0.012"	0.34 mm	0.013"
Centrifugal Force:						
High Amplitude	76.9 kN	17,288 lb	73.8 kN	16,591 lb	107 kN	24,055 lb
Low Amplitude	30.2 kN	6789 lb	59.2 kN	13,309 lb	34.6 kN	7778 lb
General Dimensions:						
Overall Width	1670 mm	5'6"	1664 mm	5'6"	1872 mm	6'2"
Drum Width	1500 mm	4'11"	1500 mm	4'11"	1700 mm	5'7"
Drum Diameter	1100 mm	3'7"	1100 mm	3'7"	1200 mm	3'11"
Overall Height (ROPS)	2980 mm	9'9"	2940 mm	9'8"	2982 mm	9'9"
Wheelbase	3300 mm	10'10"	3120 mm	10'3"	3300 mm	10'10"
Overall Length	4565 mm	14'11"	4284 mm	13'10"	4565 mm	14'11"
Curb Clearance	898 mm	35"	663 mm	26"	934 mm	37"
Ground Clearance	226 mm	9"	273 mm	10"	268 mm	10"
Service Refill Capacities:						
Fuel Tank	208 L	55 U.S. gal	135 L	36 U.S. gal	208 L	55 U.S. gal
Crankcase	9 L	2.4 U.S. gal	9 L	2.4 U.S. gal	9 L	2.4 U.S. gal
Hydraulic Tank	36 L	9.5 U.S. gal	36 L	9.5 U.S. gal	36 L	9.5 U.S. gal
Sprinkler Water	742 L	196 U.S. gal	600 L	159 U.S. gal	837 L	221 U.S. gal

¹Weights reflect solid drum configuration with ROPS/FOPS canopy.

²Weights reflect split drum configuration with ROPS/FOPS cab.

³With 5-Amp vibratory system. Other systems available.

⁴With Dual Amp — Dual Frequency vibratory system. Other systems available.

MODEL	CD54B ^{2,4}		CB54 XW ^{1,3}		CB64	
Gross Power	75 kW	100 hp	102 kw	137 hp	102 kw	137 hp
Rated Engine RPM	2200 rpm		2200 rpm		2200 rpm	
No. Cylinders	4		4		4	
Displacement	3.4 L	207.5 in ³	4.4 L	269 in ³	4.4 L	269 in ³
Engine Model	C3.4B ACERT		C4.4 ACERT		C4.4 ACERT	
Emission Standards	Tier 4 Final/Stage IV		Tier 3/Stage IIIA equivalent		Tier 3/Stage IIIA equivalent	
Speeds	2 forward/2 reverse		2 forward/2 reverse		2 forward/2 reverse	
Max. Speed (For./Rev.)	12 km/h	7.5 mph	13 km/h	8 mph	13 km/h	8 mph
Working Speed	0-12 km/h	0-7.5 mph	0-13 km/h	0-8 mph	0-13 km/h	0-8 mph
Approximate Operating Weight	10 120 kg	22,311 lb	11 898 kg	26,230 lb	12 980 kg	28,616 lb
Drive	Hydraulic		Hydraulic		Hydraulic	
Steering:						
Inside Radius	2842 mm	9'4"	4000 mm	13'1"	3940 mm	12'11"
Outside Radius	4541 mm	14'11"	6000 mm	19'8"	6070 mm	19'11"
Steering Angle	±25°		±40°		±40°	
Vibratory System:						
Ecc. Weight Drive	Hydraulic		Hydraulic		Hydraulic	
Frequency	42/53.3 Hz	2520/ 3200 vpm	42 Hz	2520 vpm	42 Hz	2520 vpm
Amplitude:						
High Amplitude	0.61 mm	0.023"	0.86 mm	0.034"	1.03 mm	0.041"
Low Amplitude	0.33 mm	0.013"	0.30 mm	0.012"	0.26 mm	0.010"
Centrifugal Force:						
High Amplitude	86.7 kN	19,491 lb	110 kN	24,929 lb	138.2 kN	31,100 lb
Low Amplitude	75.5 kN	16,973 lb	35 kN	7922 lb	82.6 kN	18,570 lb
General Dimensions:						
Overall Width	1874 mm	6'2"	2205 mm	7'3"	2335 mm	7'8"
Drum Width	1700 mm	5'7"	2000 mm	6'7"	2130 mm	7'0"
Drum Diameter	1200 mm	3'11"	1300 mm	4'3"	1300 mm	4'3"
Overall Height (ROPS)	2985 mm	9'9"	3050 mm	10'1"	3050 mm	10'1"
Wheelbase	3120 mm	10'3"	3640 mm	11'11"	3640 mm	11'11"
Overall Length	4322 mm	14'2"	4934 mm	16'2"	4934 mm	16'2"
Curb Clearance	808 mm	31"	868 mm	34.2"	868 mm	34.2"
Ground Clearance	272 mm	10"	217 mm	8.5"	217 mm	8.5"
Service Refill Capacities:						
Fuel Tank	191 L	50 U.S. gal	191 L	50 U.S. gal	191 L	50 U.S. gal
Crankcase	9 L	2.4 U.S. gal	9 L	2.4 U.S. gal	9 L	2.4 U.S. gal
Hydraulic Tank	36 L	9.5 U.S. gal	58.7 L	15.5 U.S. gal	58.7 L	15.5 U.S. gal
Sprinkler Water	750 L	198 U.S. gal	1100 L	291 U.S. gal	1100 L	291 U.S. gal

¹Weights reflect solid drum configuration with ROPS/FOPS canopy.

²Weights reflect split drum configuration with ROPS/FOPS cab.

³With 5-Amp vibratory system. Other systems available.

⁴With Dual Amp — Dual Frequency vibratory system. Other systems available.

MODEL	CB64B		CB66B		CB68B	
Gross Power	106 kW	142 hp	106 kW	142 hp	106 kW	142 hp
Rated Engine RPM	2200 rpm		2200 rpm		2200 rpm	
No. Cylinders	4		4		4	
Displacement	4.4 L		4.4 L		4.4 L	
Engine Model	C4.4 ACERT		C4.4 ACERT		C4.4 ACERT	
Emission Standards	Tier 4 Final/Stage IV		Tier 4 Final/Stage IV		Tier 4 Final/Stage IV	
Speeds	2 forward/2 reverse		2 forward/2 reverse		2 forward/2 reverse	
Max. Speed (For./Rev.)	13 km/h	8 mph	13 km/h	8 mph	13 km/h	8 mph
Working Speed	0-13 km/h	0-8 mph	0-13 km/h	0-8 mph	0-13 km/h	0-8 mph
Approximate Operating Weight	12 000 kg	26,455 lb	13 000 kg	28,660 lb	14 000 kg	30,865 lb
Drive	Hydraulic		Hydraulic		Hydraulic	
Steering:						
Inside Radius	4200 mm	13'10"	4100 mm	13'8"	4100 mm	13'8"
Outside Radius	6200 mm	20'5"	6230 mm	20'8"	6230 mm	20'8"
Steering Angle	±36.5°		±36.5°		±36.5°	
Vibratory System:						
Ecc. Weight Drive	Hydraulic		Hydraulic		Hydraulic	
Frequency	42 Hz	2520 vpm	42 Hz	2520 vpm	42 Hz	2520 vpm
Amplitude:						
High Amplitude	0.96 mm	0.038"	0.96 mm	0.038"	0.96 mm	0.038"
Low Amplitude	0.30 mm	0.012"	0.30 mm	0.012"	0.30 mm	0.012"
Centrifugal Force:						
High Amplitude	110 kN	24,728 lb	110 kN	24,728 lb	110 kN	24,728 lb
Low Amplitude	34.7 kN	7800 lb	34.7 kN	7800 lb	34.7 kN	7800 lb
General Dimensions:						
Overall Width	2325 mm	7'8"	2325 mm	7'8"	2325 mm	7'8"
Drum Width	2000 mm	6'7"	2130 mm	7'0"	2130 mm	7'0"
Drum Diameter	1300 mm	4'3"	1300 mm	4'3"	1300 mm	4'3"
Overall Height (ROPS)	3050 mm	10'0"	3050 mm	10'0"	3050 mm	10'0"
Wheelbase	3450 mm	11'4"	3450 mm	11'4"	3450 mm	11'4"
Overall Length	4600 mm	15'1"	4600 mm	15'1"	4600 mm	15'1"
Curb Clearance	723 mm	28.5"	723 mm	28.5"	723 mm	28.5"
Ground Clearance	295 mm	11.6"	295 mm	11.6"	295 mm	11.6"
Service Refill Capacities:						
Fuel Tank	250 L	66 U.S. gal	250 L	66 U.S. gal	250 L	66 U.S. gal
Crankcase	8.1 L	2.1 U.S. gal	8.1 L	2.1 U.S. gal	8.1 L	2.1 U.S. gal
Hydraulic Tank	36 L	9.5 U.S. gal	36 L	9.5 U.S. gal	36 L	9.5 U.S. gal
Sprinkler Water	1000 L	264 U.S. gal	1000 L	264 U.S. gal	1000 L	264 U.S. gal

MODEL	PS150C ¹		CW14 ¹		PS360C ³		CW34	
Gross Power	75 kW	100 hp	75 kW	100 hp	98 kW	130 hp	98 kW	131 hp
Rated Engine RPM	2200		2200 rpm		2200		2200 rpm	
No. Cylinders	4		4		4		4	
Displacement	4.4 L	269 in³	3.4 L	207.5 in³	4.4 L	269 in³	4.4 L	269 in³
Engine Model	3054C		C3.4B		3054C ATAAC		C4.4 ACERT	
Emission Standards	Tier 2/Stage II equivalent		Tier 4 Final/Stage IV		Tier 2/Stage II equivalent		Tier 4 Final/Stage IV	
Speeds	2 forward/2 reverse		—		2 forward/2 reverse		—	
Max. Speed (For./Rev.)	25.6 km/h	15.9 mph	18 km/h	11 mph	18 km/h	11 mph	19 km/h	12 mph
Working Speed	11 km/h	6.8 mph	0-18 km/h	0-11 mph	8 km/h	5 mph	0-19 km/h	0-12 mph
Wheel Configuration	5 front/4 rear		5 front/4 rear		3 front/4 rear		4 front/4 rear	
Tires	8.50/90 × 15-6 ply		8.50/90 × 15-6 ply		14/70 × 20-20 ply		13/80-R20	
Operating Weight Empty (No ballast) ²	4885 kg	10,775 lb	4885 kg	10,775 lb	8580 kg	18,915 lb	10 000 kg	22,050 lb
Operating Weight Full (Max. ballast) ²	12 940 kg	28,535 lb	12 940 kg	28,535 lb	18 500 kg	40,785 lb	27 000 kg	59,525 lb
Maximum Weight per Wheel	1440 kg	3180 lb	1440 kg	3180 lb	3571 kg	7873 lb	3380 kg	7452 lb
Shipping Weight	4805 kg	10,580 lb	4805 kg	10,580 lb	8500 kg	18,740 lb	—	—
Drive	Hydraulic		Hydraulic		Hydraulic		Hydraulic	
Steering:								
Inside Radius	4648 mm	15'3"	4648 mm	15'3"	3470 mm	11'5"	6097 mm	20'0"
Outside Radius	6453 mm	21'2"	6453 mm	21'2"	6700 mm	22'0"	8672 mm	28'5"
General Dimensions:								
Overall Width	1740 mm	5'8"	1740 mm	5'8"	2280 mm	7'6"	2160 mm	7'1"
Rolling Width	1740 mm	5'8"	1740 mm	5'8"	2280 mm	7'6"	2090 mm	6'10"
Tire Width	191 mm	7.5"	191 mm	7.5"	368 mm	14.5"	298 mm	11.7"
Tire Overlap	13 mm	0.5"	13 mm	0.5"	58 mm	2.25"	42 mm	1.7"
Overall Height (ROPS)	3000 mm	9'10"	3000 mm	9'10"	3200 mm	10'6"	3000 mm	9'10"
Wheelbase	3340 mm	10'11"	3340 mm	10'11"	3650 mm	12'0"	3900 mm	12'9"
Overall Length	4290 mm	14'1"	4290 mm	14'1"	4870 mm	16'0"	5350 mm	17'6"
Ground Clearance	267 mm	10.5"	267 mm	10.5"	252 mm	10"	260 mm	10"
Service Refill Capacities:								
Fuel Tank	173 L	45.6 U.S. gal	173 L	45.6 U.S. gal	200 L	52 U.S. gal	270 L	71 U.S. gal
Crankcase	7.3 L	1.9 U.S. gal	7.3 L	1.9 U.S. gal	7.3 L	1.9 U.S. gal	9 L	2.4 U.S. gal
Hydraulic Fluid	54.9 L	14.5 U.S. gal	54.9 L	14.5 U.S. gal	90 L	23.7 U.S. gal	32 L	8.5 U.S. gal
Sprinkler Water	394 L	104 U.S. gal	394 L	104 U.S. gal	394 L	104 U.S. gal	380 L	100 U.S. gal

¹11-wheel configuration available.²With ROPS.³Combined ballast available for an operating weight of 25 022 kg (55,115 lb) for PS360C.

Pneumatic Tires — Bias Ply and Radial

Model	Tire Size	Ply Rating	Tire Inflation Pressure			
			Minimum Pressure		Maximum Pressure	
			kPa	psi	kPa	psi
PS150C, CW14	8.5 × 15	6	275	40	344	50
	7.5 × 15	12	344	50	757	110
	7.5 × 15	14	344	50	862	125
	7.5R15	Radial	296	43	480	70
CW34	13/80-R20	Radial	300	44	900	131
PS360C	14/70 × 20	20	241	35	757	110

Ballast Configurations

Model	Load	Ballast Configuration					
		Empty	Water Only	Steel Only	Wet Sand Only	Steel and Water	Steel and Wet Sand
PS150C, CW14	Wheel Load	545 kg 1200 lb	970 kg 2145 lb	* *	1440 kg 3180 lb	* *	* *
	Machine Weight	4885 kg 10,775 lb	8710 kg 19,205 lb	* *	12 940 kg 28,535 lb	* *	* *
PS150C, CW14 (11-wheel)	Wheel Load	450 kg 993 lb	798 kg 1760 lb	* *	1183 kg 2608 lb	* *	* *
	Machine Weight	4955 kg 10,925 lb	8780 kg 19,355 lb	* *	13 010 kg 28,685 lb	* *	* *
PS150C, CW14 (Heavy Weight Option)	Wheel Load	457 kg 1008 lb	805 kg 1775 lb	* *	1189 kg 2621 lb	* *	* *
	Machine Weight	5025 kg 11,078 lb	8850 kg 19,511 lb	* *	13 080 kg 28,836 lb	* *	* *
CW34	Wheel Load	1250 kg 2756 lb	1620 kg 3572 lb	2820 kg 6217 lb	2000 kg 4409 lb	3080 kg 6790 lb	3375 kg 7441 lb
	Machine Weight	10 000 kg 22,050 lb	13 000 kg 28,660 lb	22 550 kg 49,715 lb	16 000 kg 35,275 lb	24 700 kg 54,450 kg	27 000 kg 59,525 lb
PS360C	Wheel Load	1215 kg 2675 lb	1930 kg 4250 lb	2285 kg 5040 lb	2645 kg 5830 lb	2855 kg 6300 lb	3570 kg 7870 lb
	Machine Weight	8500 kg 18,740 lb	13 500 kg 29,760 lb	15 995 kg 35,265 lb	18 500 kg 40,785 lb	20 000 kg 44,090 lb	25 000 kg 55,115 lb

*Configuration not available.

Specifications

- Maximum Ground Pressures
- Ground Contact Pressure — CW34

Pneumatic Tire Compactors

Maximum Ground Pressures

Model	Ply Rating	Empty	Water Only	Steel Only	Wet Sand Only	Steel and Water	Steel and Wet Sand
PS150C, CW14	6	469 kPa 68 psi	689 kPa 100 psi	* *	655 kPa 95 psi	* *	* *
	12	469 kPa 68 psi	724 kPa 105 psi	* *	758 kPa 110 psi	* *	* *
	14	469 kPa 68 psi	1041 kPa 151 psi	* *	972 kPa 141 psi	* *	* *

*Configuration not available.

NOTES:

1. Each tire type has a unique pressure distribution which varies with both tire inflation pressure and wheel load. The distribution of pressure along both transverse and longitudinal profiles is rarely uniform.
2. The measurements in this table represent the peak pressures measured in a transverse profile at each of the ballast conditions at maximum tire inflation pressure.
3. For most applications, it can be assumed that normal operation of the pneumatic compactor will result in the ground being subjected to pressures near the maximum during at least one machine pass.

Ground Contact Pressure — CW34

Average Wheel Load	Tire Pressure							
	300 kPa 44 psi	400 kPa 58 psi	500 kPa 73 psi	600 kPa 87 psi	700 kPa 102 psi	800 kPa 116 psi	850 kPa 123 psi	900 kPa 131 psi
1500 kg 3307 lb	242 kPa 35 psi	309 kPa 45 psi	406 kPa 59 psi	612 kPa 89 psi	680 kPa 99 psi	1038 kPa 151 psi	1265 kPa 184 psi	1587 kPa 230 psi
2000 kg 4410 lb	260 kPa 38 psi	299 kPa 43 psi	357 kPa 52 psi	462 kPa 67 psi	498 kPa 72 psi	628 kPa 91 psi	691 kPa 100 psi	764 kPa 111 psi
2500 kg 5512 lb	308 kPa 45 psi	322 kPa 47 psi	360 kPa 52 psi	429 kPa 62 psi	458 kPa 66 psi	539 kPa 78 psi	577 kPa 84 psi	618 kPa 90 psi
3000 kg 6614 lb	397 kPa 58 psi	369 kPa 54 psi	386 kPa 56 psi	433 kPa 63 psi	457 kPa 66 psi	516 kPa 75 psi	543 kPa 79 psi	573 kPa 83 psi
3375 kg 7441 lb	518 kPa 75 psi	423 kPa 61 psi	418 kPa 61 psi	448 kPa 65 psi	469 kPa 68 psi	517 kPa 75 psi	539 kPa 78 psi	564 kPa 82 psi

The tables in this section give production estimates for the following assumed conditions:

Nominal machine travel speed: 6.4 km/h (4.0 mph)

Overlap of rolling width: 15.2 cm (6.0 inches)

Table values give **representative** production rates for three common construction conditions: trenches, roads, and wide areas (> 15 m, or 50 ft).

Model	Drum Width		Lift Thickness		Passes Required	Production Estimates			
	cm	in	cm	in		3.7 m (12 ft) Trench	9.15 m (30 ft) Road Base	Wide Areas	
CS423E, CS44	167.6	66	10.2	4	4	m ³ /hr yds ³ /hr	159 209	249 326	249 326
CS533E, CS54, CS56, CS54B, CS56B, CS64B, CS66B	213.4	84	15.2	6	6	m ³ /hr yds ³ /hr	239 313	299 391	324 424
CS64, CS68B	213.4	84	15.2	6	5	m ³ /hr yds ³ /hr	— 489	373 489	405 530
CS74, CS74B	213.4	84	15.2	6	4	m ³ /hr yds ³ /hr	— 587	448 587	486 636
CS76, CS76B	213.4	84	15.2	12	6	m ³ /hr yds ³ /hr	— 782	598 782	648 848
CS76 XT, CS78B	213.4	84	15.2	12	4	m ³ /hr yds ³ /hr	— 1174	896 1174	972 1272
CP44	167.6	66	15.2	6	6	m ³ /hr yds ³ /hr	159 209	199 261	249 326
CP533E, CP54, CP56, CP54B, CP56B	213.4	84	30.5	12	6	m ³ /hr yds ³ /hr	478 626	478 626	647 847
CP76, CP68B, CP74B	213.4	84	30.5	12	6	m ³ /hr yds ³ /hr	— 782	598 782	648 848

Travel Speed Efficiency

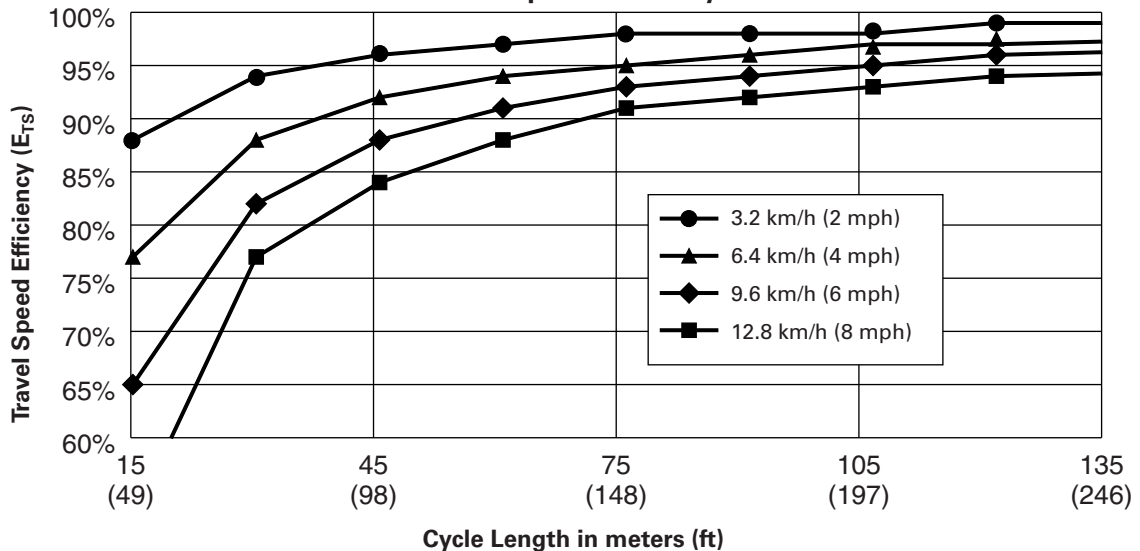

Adjusting the Production Estimate

If the assumed conditions are not close to the actual construction conditions, the production estimates should be corrected. The production estimate from the table can be adjusted for 'actual' construction conditions by applying adjustment factors:

$$Q (\text{actual}) = Q (\text{assumed}) \times F_s \times F_t \times F_p$$

- Where: Q (actual) = adjusted productivity
- Q (assumed) = productivity from table based on assumed conditions
- F_s = adjustment for machine speed
- F_t = adjustment for layer thickness
- F_p = adjustment for no. of passes

The adjustment factors are determined by comparing the 'actual' conditions to the 'assumed' ones:

- F_s = actual speed/assumed speed
- F_t = actual thickness/assumed thickness
- F_p = assumed passes/actual passes

Metric example

Actual Conditions — An 9.15-meter (full road width) base aggregate job is being completed with a compacted thickness of 15 cm. A CS44 is being used, operating at 4.0 km/h, and making 6 passes to achieve the desired compaction. The roller is overlapping its passes 6 inches.

For a 9.15-meter road base the table gives a CS44 productivity of 249 m³/hr. Since the speed, thickness, and passes are *different* from the assumed conditions, we should adjust this estimate:

	Assumed	Actual
Speed	6.4 km/h	4.0 km/h
Thickness	10.2 cm	15 cm
Passes	4 passes	6 passes

- F_s = 4.0 km/h/6.4 km/h = 0.6
- F_t = 15 cm/10.2 cm = 1.5
- F_p = 4 passes/6 passes = 0.7

The estimated production is adjusted using these factors:

$$Q (\text{actual}) = 249 \text{ m}^3/\text{hr} \times 0.6 \times 1.7 \times 0.7 = 178 \text{ m}^3/\text{hr} (233 \text{ yds}^3/\text{hr})$$

English example

Actual Conditions — An wide area commercial site development job is being compacted in lifts of 8 inches. A CP56 is being used, operating at 4.0 mph, and making 4 passes to achieve the target density.

First, the table gives a CP56 productivity of 847 yds³/hr. Since lift thickness and passes required are *different* from the assumed conditions, we should adjust this estimate:

	Assumed	Actual
Speed	4.0 mph	4.0 mph
Thickness	12 inches	8 inches
Passes	6 passes	4 passes

- F_s = no correction necessary
- F_t = 8 inches/12 inches = 0.7
- F_p = 6 passes/4 passes = 1.5

The estimated production is adjusted using these factors:

$$Q (\text{actual}) = 847 \text{ yds}^3/\text{hr} \times 0.7 \times 1.5 = 890 \text{ yds}^3/\text{hr} (680 \text{ m}^3/\text{hr})$$

Notes on Productivity:

- For jobs that are relatively narrow, especially road construction jobs, it is important to understand that certain widths of construction will be more productive than others for a given compactor. A productive construction width will make the most use of each side by side pass required by the compactor in order to cover the width.
- Production estimates should be adjusted further if the length of the compaction cycles are shorter than 75 m (250 ft). Refer to the Travel Speed Efficiency chart to determine efficiency E_{TS}. For example, a compactor traveling at 6.4 km/h (4 mph) operating at cycle lengths of 150 ft has an E_{TS} of 0.91. Multiply Q (actual) by E_{TS}.

The table in this section gives production estimates for the following assumed conditions:

Compacted Layer Thickness	51 mm	2 in
Maximum Vibratory Frequency*	—	—
Impacts Spacing	33 impacts/m	10 impacts/ft
Passes per Machine Width	2	2
Compacted Material Density	2483 kg/m ³	155 lb/ft³
Overlap of Rolling Width	152 mm	6 in
Overhang at Lane Edge	76 mm	3 in
Efficiency		75%

*Maximum vibratory frequency varies by machine, refer to table.

Table values give **representative** production rates for common construction widths. If the actual width falls between two assumed widths, use the higher number to estimate production. Minor adjustments can normally be made in the rolling method to reach this higher production: reduce overlap or overhang, increase speed, or increase the cycle time.

Model	Vibration Frequency	Units	PAVING WIDTH						
			1.8 m 6 ft	2.4 m 8 ft	3.0 m 10 ft	3.7 m 12 ft	4.3 m 14 ft	4.9 m 16 ft	5.5 m 18 ft
CB14B	53.3 Hz	Tonnes/hr	144.6	150.0	153.4	155.8	—	—	—
	3200 vpm	tons/hr	159.4	165.3	169.1	171.7	—	—	—
CB14B XW (1000 mm/39")	53.3 Hz	Tonnes/hr	144.6	192.9	187.5	184.1	—	—	—
	3200 vpm	tons/hr	159.4	212.6	206.7	202.9	—	—	—
CB22B	63 Hz	Tonnes/hr	170.8	227.8	221.4	217.5	214.6	245.3	239.2
	3780 vpm	tons/hr	188.3	251.1	244.1	239.7	236.6	270.4	263.7
CB24B, CB24B XT, and CC24B	63 Hz	Tonnes/hr	239.2	227.8	284.8	265.8	253.6	289.9	276.0
	3780 vpm	tons/hr	263.7	251.1	313.9	293.0	279.6	319.6	304.2
CB32B	63 Hz	Tonnes/hr	239.2	227.8	284.8	265.8	310.1	289.9	326.1
	3780 vpm	tons/hr	263.7	251.1	313.9	293.0	341.8	319.6	359.5
CB34B and CC34B	69 Hz	Tonnes/hr	262.0	249.5	311.9	291.1	339.6	317.5	357.2
	4140 vpm	tons/hr	288.8	275.0	343.8	320.9	374.3	350.0	393.8
CB32B XW	53 Hz	Tonnes/hr	201.2	268.3	239.6	287.5	260.8	298.1	274.4
	3180 vpm	tons/hr	221.8	295.7	264.1	316.9	287.5	328.6	302.5
CB434D, CB44B	70 Hz	Tonnes/hr	265.8	354.3	316.4	379.7	344.5	393.7	362.4
	4200 vpm	tons/hr	293.0	390.6	348.8	418.5	379.8	434.0	399.5
CD44B	53 Hz	Tonnes/hr	201.2	268.3	239.6	287.5	260.8	298.1	274.4
	3200 vpm	tons/hr	221.8	295.7	264.1	316.9	287.5	328.6	302.5
CB434D XW	70 Hz	Tonnes/hr	265.8	354.3	443.0	379.7	442.9	393.7	442.9
	4200 vpm	tons/hr	293.0	390.6	488.3	418.5	488.3	434.0	488.3
CB54, CB54B	63.3 Hz	Tonnes/hr	240.5	320.6	400.8	343.5	400.8	356.3	400.8
	3800 vpm	tons/hr	265.1	353.4	441.8	378.6	441.8	392.7	441.8
CB54 XW	63.3 Hz	Tonnes/hr	400.8	320.6	400.8	480.9	400.8	458.0	515.3
	3800 vpm	tons/hr	441.8	353.4	441.8	530.1	441.8	504.9	568.0
CB64	63.3 Hz	Tonnes/hr	400.8	320.6	400.8	480.9	400.8	458.0	515.3
	3800 vpm	tons/hr	441.8	353.4	441.8	530.1	441.8	504.9	568.0
CD54, CD54B	63.3 Hz	Tonnes/hr	201.2	191.6	239.6	223.6	260.8	243.9	274.4
	3800 vpm	tons/hr	221.8	211.2	264.1	246.5	287.5	268.9	302.5

Example

Actual Conditions — A 3.7 m (12 ft) lane is being paved with a compacted asphalt thickness of 10 cm (4 in). A CB54 is operating with a frequency of 42 Hz (2520 vpm) and 46 impacts per meter (14 impacts per ft) and making 4 passes to achieve target density. The roller is overlapping its passes 15 cm (6 in) and is overhanging the edges by 7.5 cm (3 in).

First, the table gives a CB54 productivity of 343 Tonnes/hr (378.6 tons/hr) for a 3.7 m (12 ft) paving width. Since the actual vibratory speed, thickness, impact spacing and passes are different from the assumed conditions, the estimate should be adjusted.

	Assumed	Actual
Vibratory Speed	63.3 Hz 3800 vpm	42 Hz 2520 vpm
Impact Spacing	33 impacts/m 10 impacts/ft	46 impacts/m 14 impacts/ft
Thickness	5 cm 2 in	10 cm 4 in
Passes	2	4

$$F_s = 42 \text{ Hz (2520 vpm)} / 63.3 \text{ Hz (3800 vpm)} = 0.66$$

$$F_i = 33 \text{ impacts/m (10 impacts/ft)} / 46 \text{ impacts/m (14 impacts/ft)} = 0.71$$

$$F_t = 10 \text{ cm (4 in)} / 5 \text{ cm (2 in)} = 2.0$$

$$F_p = 2 \text{ passes} / 4 \text{ passes} = 0.5$$

The actual, or adjusted, production estimate can then be determined from the following:

$$Q \text{ (actual)} = 343 \text{ Tonnes/hr (378.6 tons/hr)} \\ \times 0.66 \times 0.71 \times 2 \times 0.5 = \\ 161 \text{ Tonnes/hr (177.4 tons/hr)}$$

Notes on Productivity:

- Higher speed usually results in lower density achieved per pass.
- Productivity on uphill slopes may be reduced.
- Tabulated production estimates assume that 1 pass is used for re-positioning the machine at the beginning of the next run.

The tables in this section give production estimates for the following assumed conditions:

	Hot Mix Asphalt		Soil and Aggregate		Cold In-Place Recycled Asphalt	
Compacted Layer Thickness	51 mm	2 in	152 mm	6 in	203 mm	8 in
Maximum Propelling Speed	8 km/h	5 mph	8 km/h	5 mph	4.8 km/h	3 mph
Passes per Machine Width	4		4		6	
Compacted Material Density	2486 kg/cm ³	155 lb/ft³	2085 kg/cm ³	130 lb/ft³	2246 kg/cm ³	140 lb/ft³
Overlap of Rolling Width	152 mm	6 in	152 mm	6 in	152 mm	6 in
Overhang at Lane Edge	76 mm	3 in	76 mm	3 in	76 mm	3 in
Cycle Time (2 passes)	120 seconds		120 seconds		120 seconds	

Table values give **representative** production rates for common construction widths. If the actual width falls between two assumed widths, use the higher number to estimate production. Minor adjustments can normally be made in the rolling method to reach this higher production: reduce overlap or overhang, increase speed, or increase the cycle time.

Hot Mix Asphalt		PAVING WIDTH						
Model	Units	1.8 m 6 ft	2.4 m 8 ft	3.0 m 10 ft	3.7 m 12 ft	4.3 m 14 ft	4.9 m 16 ft	5.5 m 18 ft
PS150C, CW14	Tonnes/hr tons/hr	195.2 215.1	260.2 286.8	325.3 358.6	270.2 297.9	315.3 347.5	275.5 303.7	310.0 341.7
CW34	Tonnes/hr tons/hr	323.2 356.2	239.4 263.9	299.3 329.9	359.1 395.9	419.0 461.8	331.5 365.4	372.9 411.1
PS360C	Tonnes/hr tons/hr	351.3 387.2	260.2 286.8	325.3 358.6	390.3 430.3	455.4 502.0	360.3 397.2	405.3 446.8

Soil and Aggregate		1.8 m	2.4 m	3.0 m	3.7 m	4.3 m	4.9 m	5.5 m
PS150C, CW14	Tonnes/hr tons/hr	490.1 540.2	653.4 720.3	816.8 900.4	678.6 748.0	791.7 872.7	691.9 762.7	778.4 858.0
CW34	Tonnes/hr tons/hr	811.6 894.6	601.1 662.7	751.5 828.4	901.8 994.0	1052.1 1159.7	832.4 917.5	936.5 1032.3
PS360C	Tonnes/hr tons/hr	882.2 972.4	653.4 720.3	816.8 900.4	980.2 1080.4	1143.5 1260.5	904.8 997.3	1017.9 1122.0

Cold In-Place Recycled Asphalt		1.8 m	2.4 m	3.0 m	3.7 m	4.3 m	4.9 m	5.5 m
PS150C, CW14	Tonnes/hr tons/hr	288.0 317.5	384.0 423.3	480.0 529.2	394.1 434.5	459.8 506.9	399.4 440.3	449.3 495.3
CW34	Tonnes/hr tons/hr	492.1 542.4	353.3 389.5	441.6 486.9	530.0 584.2	618.3 681.5	483.5 533.0	543.9 600.0
PS360C	Tonnes/hr tons/hr	534.9 589.6	384.0 423.3	480.0 529.2	576.1 635.0	672.1 740.8	525.5 579.3	591.2 651.7

Example

Actual Conditions — A 7.3 m (23'11") (full road width) base aggregate job is being completed with a compacted thickness of 200 mm (8 in). A PS150C is being used, operating at 6.5 km/h (4 mph), and making 6 passes achieve the desired compaction. The roller is overlapping its passes 152 mm (6 in).

First, the table does not show production for 7.3 m (23'11") so use the greatest width on the table: 5.5 m (18'1"). The table gives a PS150C productivity of 778.4 Tonnes/hr (858.0 tons/hr) for this paving width. We can expect that the actual productivity for 7.3 m (23'11") will be slightly higher than that. Since the speed, thickness, and passes are *different* from the assumed conditions, we should adjust this estimate:

	Assumed		Actual	
Speed	8 km/h	5 mph	6.5 km/h	4 mph
Thickness	152 mm	6 in	200 mm	8 in
Passes	4		6	

$$F_s = 6.5 \text{ km/h}/8 \text{ km/h} (4 \text{ mph}/5 \text{ mph}) = 0.8$$

$$F_t = 200 \text{ mm}/152 \text{ mm} (8 \text{ in}/6 \text{ in}) = 1.3$$

$$F_p = 4 \text{ passes}/6 \text{ passes} = 0.7$$

The estimated production is adjusted using these factors:

$$Q (\text{actual}) = 778.4 \text{ Tonnes/hr} (858.0 \text{ tons/hr}) \times 0.8 \times 1.3 \times 0.7 = 567 \text{ Tonnes/hr} (625 \text{ ton/hr})$$

Notes on Productivity:

- Ballast weight and tire pressure can significantly affect performance of a pneumatic tire compactor. Refer to machine specifications to choose the best configuration.
- Productivity on uphill grades and very thick layers (>127 mm, or 5 in) may be reduced due to a necessary reduction in speed.
- The 11-tire configuration for the PS150C is designed only for chip-and-seal applications. It is not recommended in other applications.

PIPELAYERS

CONTENTS

Features	14-1
Specifications	14-2
Lifting Capacities	14-4
Drawbar Pull Charts	14-7
Travel and Hook Speeds	14-9
Application	14-10
Extreme Slope Operation	14-12

Features:

- **Hydrostatic transmission** on PL61.
- **Planetary power shift** transmission on 572R2, PL83 and PL87 models.
- **Kick-out helps prevent boom bending** as boom approaches near-vertical.
- **Sealed and Lubricated Track.**
- **Simplified Controls** for all functions including raise, lower, quick-drop and power down, high and low range and speed adjustments.
- **Modular design of major components and accessory drive system** for simplified repair.
- **Separate, self-energizing brakes** for boom and hook winches.
- **Positive** track pin retention (PL83 and PL87).
- **Hydraulic Drawworks** with two independently driven hydraulic motors for boom and hook winches.

MODEL	PL61		572R2		
Flywheel Power	92 kW	125 hp	179 kW	240 hp	
Operating Weight (with full fuel tank and operator)	17 000 kg	37,480 lb	31 845 kg	70,206 lb	
Engine Model	C6.6 ACERT™		3176C		
Rated Engine RPM	2100		2100		
No. of Cylinders	6		6		
Displacement	6.6 L	403 in³	10.3 L	629 in³	
Lift Capacity at 1.22 m (4'0") Overhang	18 145 kg	40,000 lb	40 800 kg	90,000 lb	
Standard Boom Length	5.49 m	18'0"	6.1 m	20'0"	
Width of Standard Shoe	560 mm	22"	660 mm	26"	
Length of Track on Ground	2645 mm	8'8"	3.176 m	10'5"	
Ground Contact Area (with standard shoes)	3 m ²	4650 in²	4.19 m ²	6500 in²	
Track Gauge	2 m	6'7"	2.235 m	7'4"	
Fuel Tank Refill Capacity	295 L	78 U.S. gal	479 L	127 U.S. gal	
GENERAL DIMENSIONS:					
Height to Top of Stack	2.91 m	9'7"	3.18 m	10'5"	
Height to Top of Counterweight	2.45 m	8'1"	2.9 m	9'6"	
Height with ROPS (boom removed)	2958 mm	9'8.5"	3454 mm	11'4"	
Width, Weights Retracted	3 m	9'10"	3.66 m	12'0"	
Minimum Shipping Width (both side frames removed)	2560 mm	8'5"	2.895 m	9'6"	
Shipping Width (left frame removed)	2816 mm	9'3"	3.66 m	12'0"	
Overall Length	3.78 m	12'5"	4.74 m	15'6"	
Ground Clearance	360 mm	14"	416 mm	16.4"	
DRUMS and CABLES:					
Drum Capacity	Load	73 m	239'	80 m	263'
	Boom	49.4 m	162'	52 m	170'
Cable Diameter	Load	16 mm	0.62"	19 mm	0.75"
	Boom	16 mm	0.62"	19 mm	0.75"
Drum Diameter	Load	216 mm	8.5"	254 mm	10"
	Boom	245 mm	9.63"	224 mm	8.5"
Adjustable Counterweights		7 @		2 @	
	67.7 kg ea	149 lb ea	370 kg ea	815 lb ea	
		9 @		7 @	
	114.8 kg ea	253 lb ea	479 kg ea	1055 lb ea	
Total Weight Extendable	1231 kg	2714 lb	5073 kg	11,184 lb	
	LGP Option				
Operating Weight 610 mm (24")	17 800 kg	39,242 lb			
Shipping Width:					
Boom Removed	3200 mm	10'6"			
Counterweight Removed	3116 mm	10'3"			
Frame, Brackets, Winches Removed	2760 mm	9'1"			
Track Shoe Width	610 mm	24"			
	760 mm	30"			
Ground Contact Area:					
610 mm (24") Shoes	3.2 m ²	4690 in²			
760 mm (30") Shoes	4 m ²	6200 in²			

MODEL	PL83		PL87		
Flywheel Power	231 kW	310 hp	273 kW	366 hp	
Operating Weight (with full fuel tank and operator)	48 477 kg	106,807 lb	54 485 kg	120,123 lb	
Engine Model	C15 ACERT		C15 ACERT		
Rated Engine RPM	1850		1850		
No. of Cylinders	6		6		
Displacement	15.2 L	928 in³	15.2 L	928 in³	
Lift Capacity at 1.22 m (4'0") Overhang	72 575 kg	160,000 lb	97 069 kg	214,000 lb	
Standard Boom Length	7.3 m	24'0"	7.3 m	24'0"	
Width of Standard Shoe	710 mm	28"	864 mm	34"	
Length of Track on Ground	3.726 m	12'2"	3.726 m	12'2"	
Ground Contact Area (with standard shoes)	5.6 m ²	8677 in²	6.4 m ²	9920 in²	
Track Gauge	2.34 m	7'8"	2.54 m	8'4"	
Fuel Tank Refill Capacity	409 L	108 U.S. gal	568 L	150 U.S. gal	
GENERAL DIMENSIONS:					
Height to Top of Stack	3.454 m	11'4"	—	—	
Height to Top of Counterweight	3.429 m	11'3"	3.437 m	11'3.25"	
Height with ROPS (boom removed)	3728 mm	12'3"	3835 mm	12'7"	
Width, Weights Retracted	4.089 m	13'5"	4.343 m	14'3"	
Minimum Shipping Width (both side frames removed)	3.251 m*	10'8"*	3.860 m***	12'8"***	
Shipping Width (left frame removed)	3.810 m***	12'6"***	4.038 m***	13'3"***	
Overall Length	5.23 m	17'2"	5.486 m	18'0"	
Ground Clearance	470 mm	18.5"	457 mm	18"	
DRUMS and CABLES:					
Drum Capacity	Load	181 m	594'	181 m	594'
	Boom	181 m	594'	181 m	594'
Cable Diameter	Load	19 mm	0.75"	19 mm	0.75"
	Boom	19 mm	0.75"	19 mm	0.75"
Drum Diameter	Load	266 mm	10.5"	266 mm	10.5"
	Boom	266 mm	10.5"	266 mm	10.5"
Adjustable Counterweights		2 @		2 @	
	300 kg ea	662 lb ea	285 kg ea	628 lb ea	
		11 @		6 @	
	650 kg ea	1430 lb ea	710 kg ea	1562 lb ea	
				7 @	
			785 kg ea	1725 lb ea	
Total Weight Extendable	10 826 kg	23,817 lb	13 903 kg	30,587 lb	

*Counterweight frame, counterweight mounting brackets, boom, and boom mounting brackets removed.

**Counterweight frame, boom brackets, boom, and A-frame removed.

***Boom and counterweight only removed.

PL61

LIFTING CAPACITY* 5.49 m (18'0") BOOM

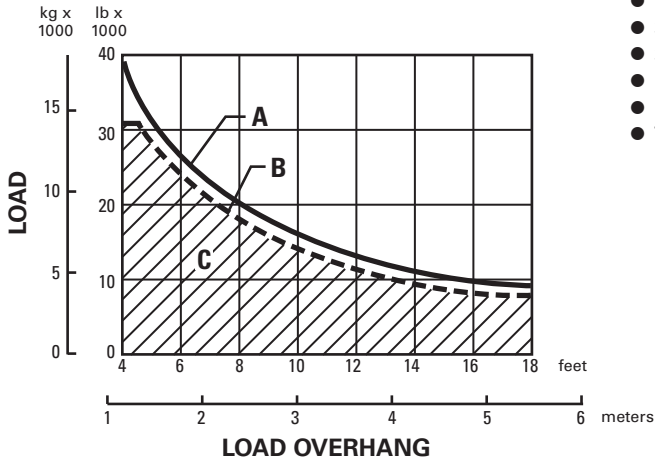

***Specified Equipment:**

- 16 mm (5/8") diameter wire rope.
- 183.3 kN (41,200 lb) minimum breaking strength.
- 3 part load line.
- 3 part boom line.
- 1231 kg (2714 lb) counterweight extended.
- Standard 5.49 m (18'0") Boom.
- Total operating weight
 - Narrow — 17 000 kg (37,480 lb).
 - LGP — 17 800 kg (39,242).

KEY

- A — Lift capacity at tipping point per ISO 8813
- B — Rated load capacity per ANSI/ASME B30.14
- C — Working range per ANSI/ASME B30.14

572R Series 2

LIFTING CAPACITY* 6.1 m or 7.3 m (20'0" or 24'0") BOOMS

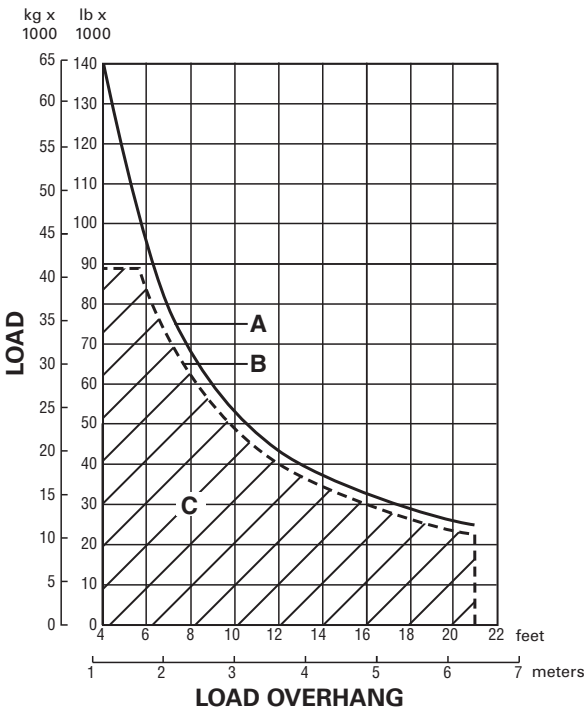

***Specified Equipment:**

- 19 mm (3/4") diameter wire rope.
- 261.66 kN (58,800 lb) minimum breaking strength.
- 4 part load line.
- 4 part boom line.
- 5073 kg (11,184 lb) counterweight extended.
- Standard 6.1 m (20'0") Boom.

KEY

- A — Max lift capacity per ISO 8813
- B — Rated load per ANSI/ASME B30.14
- C — Working range per ANSI/ASME B30.14

NOTE: ISO stands for the International Standards Organization. ANSI stands for American National Standard Institute.

PL83

LIFTING CAPACITY* 7.3 m, 8.5 m (24'0", 28'0") BOOMS

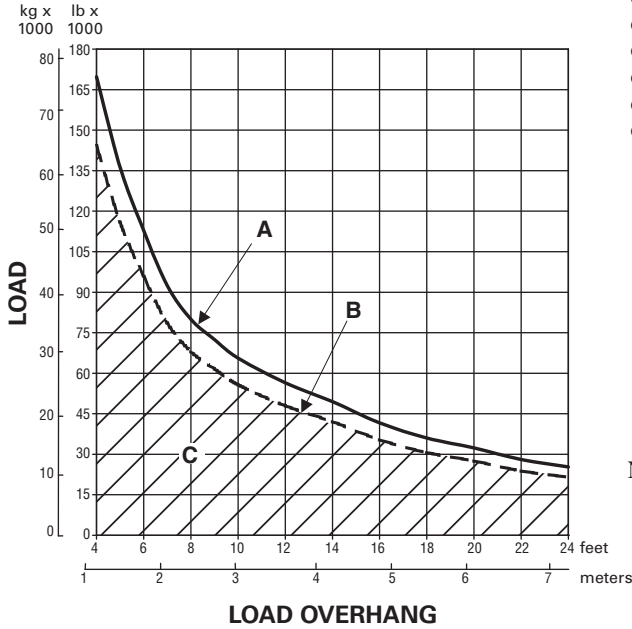

***Specified Equipment:**

- 19 mm (3/4") diameter wire rope.
- 26 672 kg (58,800 lb) minimum breaking strength.
- 6 part load line.
- 5 part boom line.
- 10 826 kg (23,817 lb) counterweight extended.
- Standard 7.3 m (24'0") Boom.
- Total operating weight 48 444 kg (106,800 lb).

KEY

- A – Max lift capacity per ISO 8813
- B – Rated load per ANSI/ASME B30.14
- C – Working range per ANSI/ASME B30.14

NOTE: ISO stands for the International Standards Organization. ANSI stands for American National Standard Institute.

PL87

LIFTING CAPACITY* 8.5 m (28'0") BOOM

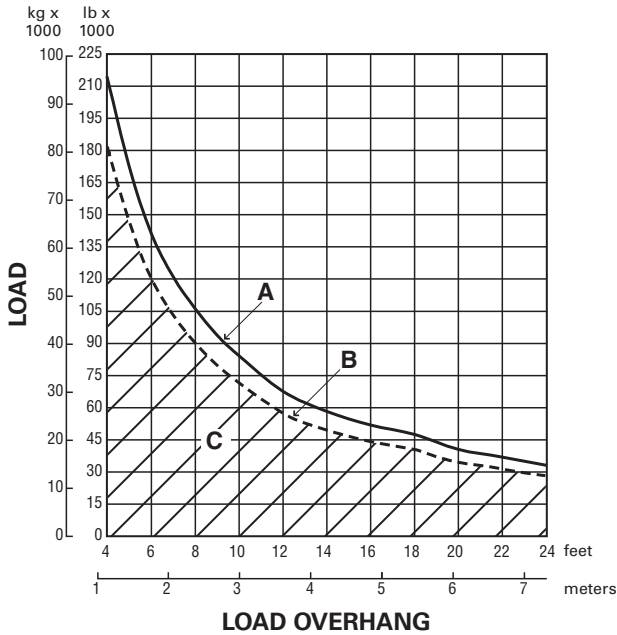

***Specified Equipment:**

- Load: 19 mm (3/4") dia. wire rope 26 672 kg (58,800 lb) minimum breaking strength.
- Boom: 19 mm (3/4") dia. wire rope 26 672 kg (58,800 lb) minimum breaking strength.
- 8 part load line.
- 5 part boom line.
- 13 903 kg (30,587 lb) counterweight extended.
- Standard 7.3 m (24'0") Boom.
- Total operating weight 54 485 kg (120,123 lb).

KEY

- A — Max lift
- B — Rated lift
- C — Working range per ANSI/ASME B30.14

NOTE: ISO stands for the International Standards Organization. ANSI stands for American National Standard Institute.

PL61

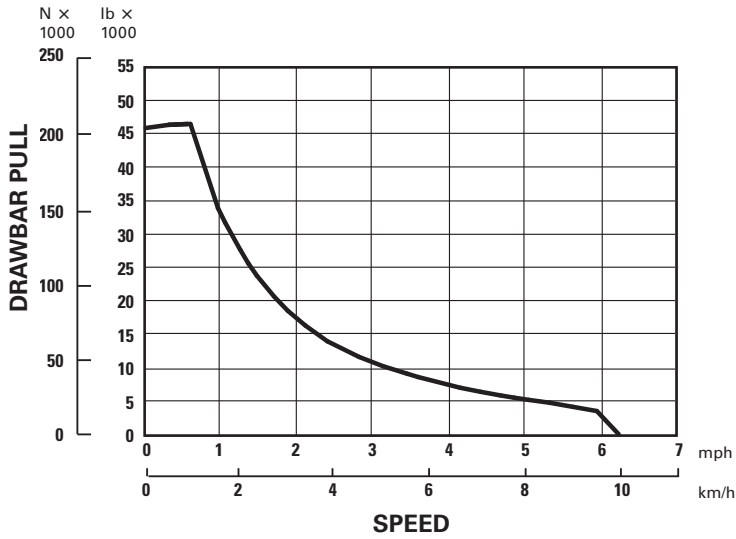

NOTE: Usable pull will depend upon weight and traction of equipped tractor.

572R Series 2

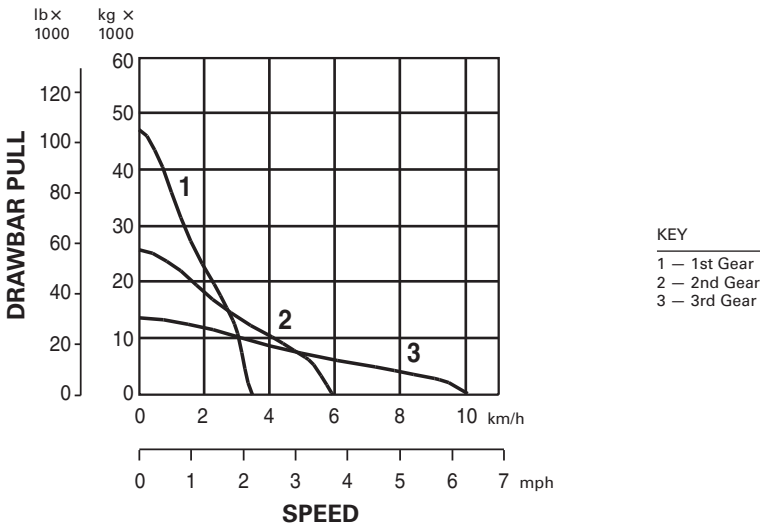

KEY
 1 — 1st Gear
 2 — 2nd Gear
 3 — 3rd Gear

PL83

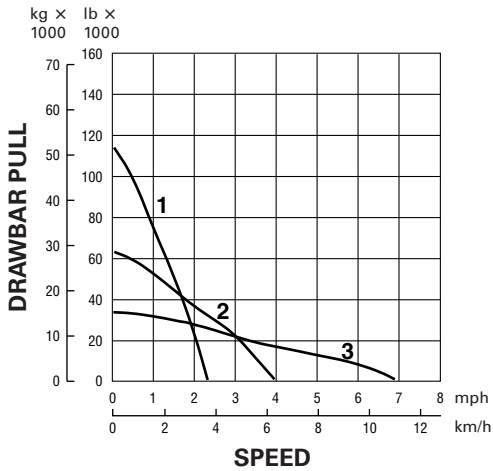

KEY
 1 — 1st Gear
 2 — 2nd Gear
 3 — 3rd Gear

PL87

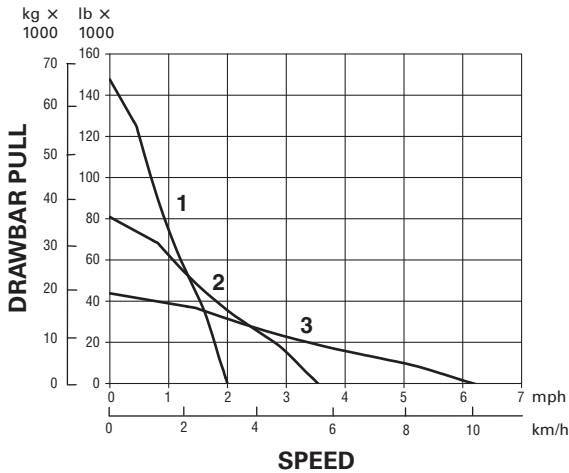

KEY
 1 — 1st Gear
 2 — 2nd Gear
 3 — 3rd Gear

MODEL	PL61				572R2			
	Forward		Reverse		Forward		Reverse	
Travel	km/h	mph	km/h	mph	km/h	mph	km/h	mph
Speeds (at rated RPM)								
1st Gear	3.1	1.9	3.8	2.3	3.5	2.2	4.5	2.8
2nd Gear	5.4	3.3	6.7	4.1	6.1	3.8	7.9	4.9
3rd Gear	10.0	6.2	10.0	6.2	10.6	6.6	13.5	8.4
Hydrostatic	10.0	6.2	10.0	6.2				

MODEL	PL83				PL87			
	Forward		Reverse		Forward		Reverse	
Travel	km/h	mph	km/h	mph	km/h	mph	km/h	mph
Speeds (at rated RPM)								
1st Gear	3.5	2.3	4.7	2.9	3.2	2.0	4.3	2.7
2nd Gear	6.4	4.0	8.1	5.0	5.8	3.6	7.6	4.7
3rd Gear	10.8	6.8	13.8	8.6	10.0	6.2	12.9	8.0

MODEL	PL61		572R2	
	m/min	ft/min	m/min	ft/min
Pipelayer Hook Speeds per minute, Bare drum at rated engine RPM				
Low Raise & Lower	33.0	108	11.0	37
Hi Raise & Lower	69.5	228	22.0	72

MODEL	PL83		PL87	
	m/min	ft/min	m/min	ft/min
Pipelayer Hook Speeds per minute, Bare drum at rated engine RPM				
Low	8.6	28.1	4.7	15.6
Hi	20.4	66.8	15.5	50.8

PIPELAYER APPLICATION CALCULATIONS:

Typical pipelayer applications on flat, firm underfoot conditions

- PL61** laying 8" to 16" pipe
- 572R2** laying 16" to 24" pipe
- PL83** laying 24" to 36" pipe
- PL87** laying 36" to 56" pipe

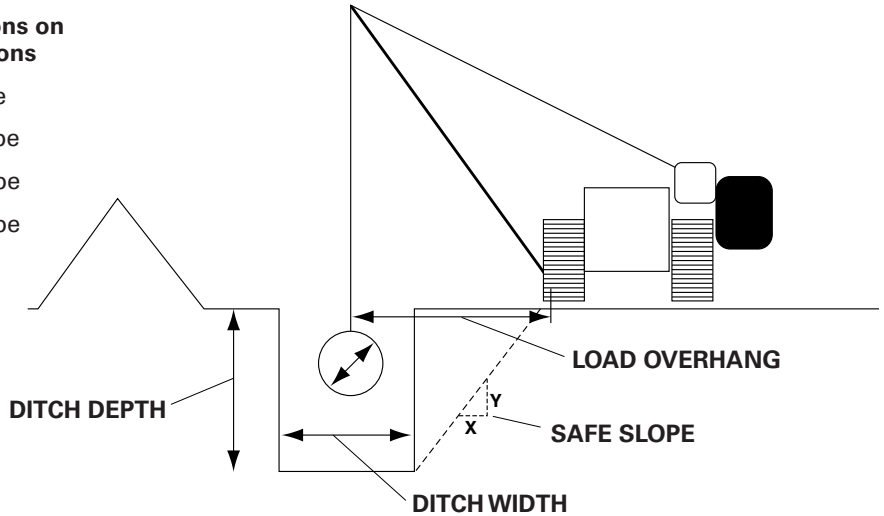

The chart above provides general information representing typical pipelayer applications. While the following scenario explores many of the variables involved in pipelaying it does not cover all the possible variables that must be considered by pipelaying contractors.

When sizing pipelayers for an application there are many considerations other than the machine's SAE rated lift capacity. These include but are not limited to:

- pipe diameter and weight per linear foot
- ditch width and depth
 - ditch width is typically $2 \times$ pipe diameter
 - ditch depth is typically $>2.5 \times$ pipe diameter
- distance from the ditch (safe slope) required by soil stability conditions
 - varies by local ground conditions but typically 2:1 (meaning the pipelayer must be $2 \times$ ditch depth from the ditch edge)

- acceptable distance between pipe lifting points while suspended (to prevent bending)
 - determined by the pipe's bending characteristics.
 - If the lifting points are too far apart a pipe can sag enough due to its own weight that it will damage itself.
- the operating safety factor desired by the contractor
- the length of pipe that will need to be suspended while laying-in
 - determined by pipe bending characteristics, terrain, etc.
- ground conditions, road bed preparation

An important consideration is the necessary load overhang. This is the distance from the center of the pipe to the tractor's left track rail. The load overhang required for an application can be estimated by:

- load overhang = safe slope × ditch depth + (0.5 × ditch width)

The pipelayer's rated load capacity at a specific load overhang (per ANSI/ASME B30.14) can be found in the load capacity graphs in this section of the performance handbook. Once the load capacity is determined the maximum lift point spacing can be estimated by:

- max lift point spacing = $\frac{\text{load capacity at load overhang}}{\text{safety factor} \times \text{pipe weight per linear foot}}$

The maximum distance between pipe lift points (based on pipe bending characteristics) may be a shorter distance than the maximum spacing between lift points as calculated based on pipelayer load capacity. If this is the case, then in order to avoid damaging the pipe, the shorter distance should be considered to be the maximum distance between pipelayers.

As an example, consider a project involving 0.5" wall 24" diameter pipe which has a weight per linear foot of 125.5 lb and the soil has a safe slope of 2. Using the above formulas:

- the ditch depth would be 3 × 2 ft = 6 ft deep
- the ditch width would be 2 × 2 ft = 4 ft
- the load overhang would be 2 × 6 ft + (0.5 × 4 ft) = 14 ft

Using the 572R2's lift capacity chart we find that the 572R2 has an ANSI rated load capacity of approximately 21,250 lb at a 14 ft load overhang.

When using rated load numbers it is important to understand that the lift capacity charts are based on SAE and ANSI test procedures that rate pipelayers on level, concrete surfaces. Working on softer underfoot conditions, working on slopes, (and other) can greatly reduce the pipelayer's load capacity.

If the contractor employs a safety factor of 2 then the maximum spacing between pipe lift points is:

$$\frac{21,250 \text{ lb}}{2 \times 125.5 \text{ lb/ft}} = 84.7 \text{ ft}$$

It is important to remember that this is the distance between the lift points, not the distance nose-to-tail between pipelayers. For this example, assume that 500 ft of pipe must be suspended during the laying-in process.

$$\frac{500 \text{ ft}}{84.7 \text{ ft per pipelayer}} = 5.9 \text{ which means that six pipelayers are needed}$$

The number of pipelayers required could also be determined by a second method:

$$\frac{\text{ft of pipe suspended} \times \text{pipe weight per ft} \times \text{safety factor}}{\text{rated load at overhang}}$$

In this case:

$$\frac{500 \text{ ft} \times 125.5 \text{ lb/ft} \times 2}{21,250 \text{ lb}} = 5.9 \text{ which again implies six pipelayers}$$

If, in this same example, soil conditions required a safe slope of 2.33 then the load overhang would have been 16 ft. At this load overhang the 90,000 lb lift pipelayer's rated load capacity is approximately 18,125 lb. Using the equations above, this results in 72.2 ft between lift points which means that seven 90,000 lb lift pipelayers are now necessary. Using the second method:

$$\frac{500 \text{ ft} \times 125.5 \text{ lb/ft} \times 2}{18,125 \text{ lb}} = 6.9 \text{ again implying that seven 90,000 lb lift pipelayers are needed}$$

Rather than adding another pipelayer, PL83's could be used. At a 16 ft load overhang the PL83 has a rated load capacity of 29,400 lb. This translates to 117.1 ft between lift points. If the pipe's bending characteristics will allow this space between lift points, the job could be done with only five PL83's.

EXTREME SLOPE OPERATION

The maximum fore and aft grade in static condition on which each track-type tractor or pipelayer will maintain proper lubrication is 45 degrees (100%). Consult Operation & Maintenance Manual (if applicable) for POWER TRAIN fluid level overfill requirements for operation on extreme slopes. Extreme slope operation is anytime the slope exceeds 25° (47%).

When working sidehills and slopes, consideration should be given to the following important points:

- Speed of travel — At higher speeds, inertia forces tend to make the tractor less stable.
- Roughness of terrain or surface — Ample allowance should be made where the terrain or surface is uneven.
- Mounted equipment — Bulldozers, sidebooms, winches, and other mounted equipment cause the tractor to balance differently.
- Nature of surface — New earthen fills may give way with the weight of the tractor. Rocky surfaces may promote side slipping of tractor.
- Track slippage due to excessive loads — This may cause downhill track to “dig in,” increasing angle of tractor.

The ENGINE should never be overfilled with oil. This may lead to rapid overheating. For extreme slope operation, engine oil should be maintained at the full mark.

NOTE: Both ENGINE and POWER TRAIN fluid levels should be checked on level ground before working sidehills and slopes.

- Implements hitched to the drawbar — This may decrease weight on uphill track, e.g., logging arch, two-wheel wagon.
- Height of hitch on tractor — When a high drawbar is used the tractor is less stable than with the standard drawbar.
- Width of shoes — Wide track shoes tend to decrease “digging in”, hence tractor is more stable.
- Operated equipment — Be aware of the stability and other performance features of the equipment operated by the tractor.
- Keep all attachments or pulled loads low to the ground for optimum stability.

NOTE: Safe operation on steep slopes may require special machine maintenance as well as excellent operator skill and proper equipment for the specific application. Consult Operation & Maintenance Manual (if applicable) for proper fluid level requirements.

SKID STEER LOADERS MULTITERRAIN LOADERS COMPACT TRACK LOADERS

CONTENTS

SKID STEER LOADERS/ MULTITERRAIN LOADERS/ COMPACT TRACK LOADERS

Features	15-2	Work Tools:	
SSL Specifications	15-3	Augers	15-105
SSL Performance Data	15-7	Brushcutters	15-108
SSL Dimensions	15-40	Cold Planers	15-110
SSL Work Tool Compatibility	15-44	Landscape Tillers	15-115
MTL Specifications	15-47	Landscape Rakes	15-117
MTL Performance Data	15-49	Mulchers	15-119
MTL Dimensions	15-64	Power Box Rakes	15-121
MTL Work Tool Compatibility	15-66	Trenchers	15-123
CTL Specifications	15-69	Vibratory Compactors	15-126
CTL Performance Data	15-72	Brooms	15-128
CTL Dimensions	15-99	Stump Grinders	15-131
CTL Work Tool Compatibility	15-102	Angle Blades	15-134
		Backhoes	15-135
		Material Handling Arm	15-136
		Snow Blowers	15-137
		Wheel Saws	15-138

Features:

- **Cat® engines** provide high horsepower, torque and S•O•SSM oil sampling ports standard.
- **Industry leading sealed and pressurized cab option** provides a cleaner and quieter operating environment with excellent Work Tool visibility on D and D2 Series machines.
- **Ergonomically designed cab** provides maximum operator comfort and visibility.
- **Low-effort joystick controls, armrest and retractable seat belt** for easy operation.
- **Available high-back, heated, air ride seat with seat mounted adjustable joystick controls** make the D and D2 Series machines the industry leaders in operator comfort.
- **Deep skid resistant steps** and two tilt cylinders makes egress/ingress easy.
- **Hand and foot throttle** for continuous or variable engine speed.
- **Anti-stall feature (B3 Series) and Electronic Torque Management (D and D2 Series)** provide maximum rimpull and hydraulic power while lugging the engine.
- **High hydraulic horsepower** gets work done quickly.
- **Direct drive hystat pumps** eliminate drive belts.
- **Ground level access** to all daily service and routine maintenance points helps reduce machine downtime for greater productivity.
- **High performance power train** provides maximum performance and production capability on D and D2 Series machines through the Electronic Torque Management system, optional two speed travel and an industry exclusive electronic hand/foot throttle with decel pedal capability.
- **Cat “Intelligent Leveling” system (ILEV)** provides industry leading technology, integration and optional features on D and D2 Series machines such as dual direction self level, work tool return to dig and work tool positioner.
- **Speed Sensitive Ride Control** option on D and D2 Series machines improves operation on rough terrain, enabling better load retention, increased productivity and greater operator comfort.
- **Maximize machine capability and control with optional Advanced Display** providing on-screen adjustment capability on D and D2 Series machines for implement response, hystat response, and creep control, multi-language functionality with customizable layouts, security system, and rearview camera.
- **High performance cooling systems and extended life coolant**, along with high performance engine and hydraulic oils, extend service intervals for low operating costs.
- **Deutsch electrical connectors** are color coded, numbered and protected with nylon braiding.
- **Electro-deposited** or “E” coat corrosion protection for long paint life.
- **High flow XPS hydraulics** are optional on most D Series machines. The XHP hydraulic package option on the 272D2, 297D2 and 299D2 combines the high pressure of XPS with even higher flow for the most demanding hydromechanical work tool applications such as mulching, cold planing, and wheel saw cutting.
- **High flow hydraulics** on the 226B3, 226D, 232D, 236D, 239D, 242D, 249D, 257D, and 259D operate more demanding, rotating work tools such as brooms, cold planers, trenchers, landscape rakes, power rakes, tillers, snow blowers, brush cutters, and stump grinders.

MODEL	216B3		226B3	
Flywheel Power: Net	35 kW	48 hp	42 kW	56 hp
Gross	38 kW	51 hp	46 kW	62 hp
Engine Model	C2.2		C2.2 T	
Rated Engine RPM	3000		3000	
Bore	84 mm	3.3"	84 mm	3.3"
Stroke	100 mm	3.9"	100 mm	3.9"
Displacement	2.2 L	134 in³	2.2 L	134 in³
No. Cylinders	4		4	
One Speed Forward	0-12.7 km/h	0-7.9 mph	0-12.7 km/h	0-7.9 mph
One Speed Reverse	0-12.7 km/h	0-7.9 mph	0-12.7 km/h	0-7.9 mph
Hydraulic Cycle Time, Empty Bucket:	Seconds		Seconds	
Raise	2.7		2.7	
Dump	2.1		2.1	
Lower (Empty, Float Down)	2.7		2.7	
Total	7.5		7.5	
Tread Width	1244 mm	4'1"	1244 mm	4'1"
Width Over Tires	1525 mm	5'0"	1525 mm	5'0"
Ground Clearance	195 mm	8.0"	195 mm	8.0"
Fuel Tank Capacity	58 L	15.4 U.S. gal	58 L	15.4 U.S. gal
Hydraulic Tank Capacity	35 L	9.2 U.S. gal	35 L	9.2 U.S. gal
Hydraulic System Capacity (includes tank)	55 L	14.5 U.S. gal	55 L	14.5 U.S. gal
Hydraulic Pump Capacity	61 L/min	16 gpm	61 L/min	16 gpm

MODEL	226D		232D	
Flywheel Power:				
Gross (SAE J1995)	50.1 kW	67.1 hp	50.1 kW	67.1 hp
Net (SAE 1349)*	49.1 kW	65.8 hp	49.1 kW	65.8 hp
Net (SAE 1349)#	44.0 kW	58.9 hp	44.0 kW	58.9 hp
Engine Model	C2.2 CRDI		C2.2 CRDI	
Rated Engine RPM	2800		2800	
Bore	84 mm	3.3"	84 mm	3.3"
Stroke	100 mm	3.9"	100 mm	3.9"
Displacement	2.2 L	134.3 in³	2.2 L	134.3 in³
No. Cylinders	4		4	
One Speed Forward	12.3 km/h	7.6 mph	12.3 km/h	7.6 mph
Two Speed Forward	17.8 km/h	11.1 mph	17.8 km/h	11.1 mph
One Speed Reverse	12.3 km/h	7.6 mph	12.3 km/h	7.6 mph
Two Speed Reverse	17.8 km/h	11.1 mph	17.8 km/h	11.1 mph
Hydraulic Cycle Time, Empty Bucket:	Seconds		Seconds	
Raise	2.6		4.4	
Dump	2.1		2.1	
Lower (Empty, Float Down)	2.9		6.6	
Total	7.6		13.1	
Tread Width, Standard	242 mm	9.5"	242 mm	9.5"
Width Over Tires	1497 mm	58.9"	1497 mm	58.9"
Ground Clearance	175 mm	6.9"	175 mm	6.9"
Fuel Tank Capacity	59 L	15.5 U.S. gal	59 L	15.5 U.S. gal
Hydraulic Tank Capacity	34 L	9.0 U.S. gal	34 L	9.0 U.S. gal
Hydraulic System Capacity (includes tank)	45 L	11.9 U.S. gal	45 L	11.9 U.S. gal
Hydraulic Pump Capacity, Standard	69 L/min	18 gpm	69 L/min	18 gpm
Hydraulic Pressure, Standard	23 000 kPa	3336 psi	23 000 kPa	3336 psi
Hydraulic Pump Capacity, XPS	99 L/min	26 gpm	99 L/min	26 gpm
Hydraulic Pressure, XPS	23 000 kPa	3336 psi	23 000 kPa	3336 psi

*Meets U.S. EPA Tier 4 Final, EU Stage IIIB, Japan 2011 (Tier 4 Interim) emission standards.

#Meets Tier 4 Interim, Stage IIIA, Japan 2006 (Tier 3) equivalent emission standards OR Tier 2, Stage II, Japan 2001 (Tier 2) equivalent emission standards.

MODEL	236D		242D		246D	
Flywheel Power:						
Gross (SAE J1995)	55.4 kW	74.3 hp	55.4 kW	74.3 hp	55.4 kW	74.3 hp
Net (SAE 1349)*	54.6 kW	73.2 hp	54.6 kW	73.2 hp	54.6 kW	73.2 hp
Net (SAE 1349)†	54.2 kW	72.7 hp	54.2 kW	72.7 hp	54.0 kW	72.4 hp
Net (SAE 1349)#	53.8 kW	72.1 hp	53.8 kW	72.1 hp	53.6 kW	71.8 hp
Engine Model	C3.3B DIT		C3.3B DIT		C3.3B DIT	
Rated Engine RPM	2400		2400		2400	
Bore	94 mm	3.7"	94 mm	3.7"	94 mm	3.7"
Stroke	120 mm	4.7"	120 mm	4.7"	120 mm	4.7"
Displacement	3.3 L	203 in³	3.3 L	203 in³	3.3 L	203 in³
No. Cylinders	4		4		4	
One Speed Forward	0-11.2 km/h	0-7.0 mph	0-12.1 km/h	0-7.5 mph	0-12.5 km/h	0-7.7 mph
Two Speed Forward	0-17.1 km/h	0-10.6 mph	0-18.5 km/h	0-11.5 mph	0-17.7 km/h	0-11.0 mph
One Speed Reverse	0-11.2 km/h	0-7.0 mph	0-12.1 km/h	0-7.5 mph	0-12.5 km/h	0-7.7 mph
Two Speed Reverse	0-17.1 km/h	0-10.6 mph	0-18.5 km/h	0-11.5 mph	0-17.7 km/h	0-11.0 mph
Hydraulic Cycle Time, Empty Bucket:	Seconds		Seconds		Seconds	
Raise	3.1		4.4		3.1	
Dump	2.4		2.4		2.5	
Lower (Empty, Float Down)	3.6		3.6		4.0	
Total	9.1		10.4		9.6	
Tread Width, Standard	1371 mm	54"	1371 mm	54"	1371 mm	54"
Width Over Tires	1676 mm	66"	1676 mm	66"	1676 mm	66"
Ground Clearance	195 mm	7.7"	222 mm	8.7"	226 mm	8.9"
Fuel Tank Capacity	105 L	27.7 U.S. gal	105 L	27.7 U.S. gal	94 L	24.8 U.S. gal
Hydraulic Tank Capacity	39 L	10.3 U.S. gal	39 L	10.3 U.S. gal	39 L	10.3 U.S. gal
Hydraulic System Capacity (includes tank)	50 L	13.2 U.S. gal	50 L	13.2 U.S. gal	52 L	13.7 U.S. gal
Hydraulic Pump Capacity, Standard	76 L/min	20 gpm	76 L/min	20 gpm	86 L/min	23 gpm
Hydraulic Pressure, Standard	23 000 kPa	3335 psi	23 000 kPa	3335 psi	23 000 kPa	3335 psi
Hydraulic Pump Capacity, XPS	112 L/min	30 gpm	112 L/min	30 gpm	121 L/min	32 gpm
Hydraulic Pressure, XPS	23 000 kPa	3335 psi	23 000 kPa	3335 psi	28 000 kPa	4061 psi

*Meets Tier 4 Final, Stage IIIB, Japan 2011 (Tier 4 Interim) emission standards.

†Meets Tier 4 Interim, Stage IIIA, Japan 2006 (Tier 3) equivalent emission standards OR Tier 2, Stage II, Japan 2001 (Tier 2) equivalent emission standards.

#Meets Tier 4 Interim, Stage IIIA, Japan 2006 (Tier 3) equivalent emission standards OR Tier 2, Stage II, Japan 2001 (Tier 2) equivalent emission standards.

MODEL	262D		272D2		272D2 XHP	
Flywheel Power:						
Gross (SAE J1995)	55.4 kW	74.3 hp	73.2 kW	98.2 hp	82.0 kW	110.0 hp
Net (SAE 1349)*	54.6 kW	73.2 hp	70.6 kW	94.7 hp	79.0 kW	105.9 hp
Net (SAE 1349)†	54.0 kW	72.4 hp	—	—	—	—
Net (SAE 1349)#	53.6 kW	71.8 hp	—	—	—	—
Engine Model	C3.3B DIT		C3.8 DIT		C3.8 DITA	
Rated Engine RPM	2400		2400		2400	
Bore	94 mm	3.7"	100 mm	3.9"	100 mm	3.9"
Stroke	120 mm	4.7"	120 mm	4.7"	120 mm	4.7"
Displacement	3.3 L	203 in³	3.8 L	231.9 in³	3.8 L	231.9 in³
No. Cylinders	4		4		4	
One Speed Forward	0-12.5 km/h	0-7.7 mph	10.6 km/h	6.6 mph	10.6 km/h	6.6 mph
Two Speed Forward	0-17.7 km/h	0-11.0 mph	15.1 km/h	9.4 mph	15.1 km/h	9.4 mph
One Speed Reverse	0-12.5 km/h	0-7.7 mph	10.6 km/h	6.6 mph	10.6 km/h	6.6 mph
Two Speed Reverse	0-17.7 km/h	0-11.0 mph	15.1 km/h	9.4 mph	15.1 km/h	9.4 mph
Hydraulic Cycle Time, Empty Bucket:	Seconds		Seconds		Seconds	
Raise	4.6		5.2		4.4	
Dump	2.3		2.3		2.0	
Lower (Empty, Float Down)	4.0		4.6		4.7	
Total	10.9		12.1		11.1	
Tread Width, Standard	1371 mm	54"	1524 mm	60"	1524 mm	60"
Width Over Tires	1676 mm	66"	1829 mm	72"	1930 mm	76"
Ground Clearance	226 mm	8.9"	226 mm	8.9"	263 mm	10.4"
Fuel Tank Capacity	94 L	24.8 U.S. gal	122 L	32.2 U.S. gal	122 L	32.2 U.S. gal
Hydraulic Tank Capacity	39 L	10.3 U.S. gal	39 L	10.3 U.S. gal	39 L	10.3 U.S. gal
Hydraulic System Capacity (includes tank)	52 L	13.7 U.S. gal	55 L	14.5 U.S. gal	55 L	14.5 U.S. gal
Hydraulic Pump Capacity, Standard	86 L/min	23 gpm	86 L/min	23 gpm	86 L/min	23 gpm
Hydraulic Pressure, Standard	23 000 kPa	3335 psi	23 000 kPa	3336 psi	23 000 kPa	3336 psi
Hydraulic Pump Capacity, XPS	121 L/min	32 gpm	121 L/min	32 gpm	—	—
Hydraulic Pressure, XPS	28 000 kPa	4061 psi	28 000 kPa	4061 psi	—	—
Hydraulic Pump Capacity, XHP	—	—	—	—	150 L/min	40 gpm
Hydraulic Pressure, XHP	—	—	—	—	28 000 kPa	4061 psi

*Meets Tier 4 Final, Stage IIIB, Japan 2011 (Tier 4 Interim) emission standards.

†Meets Tier 4 Interim, Stage IIIA, Japan 2006 (Tier 3) equivalent emission standards OR Tier 2, Stage II, Japan 2001 (Tier 2) equivalent emission standards.

#Meets Tier 4 Interim, Stage IIIA, Japan 2006 (Tier 3) equivalent emission standards OR Tier 2, Stage II, Japan 2001 (Tier 2) equivalent emission standards.

Bucket Type		General Purpose						Multi-Purpose		
Bucket Width		1520 mm (60")			1680 mm (66")			1520 mm (60")		
Tire Size		10 x 16.5			10 x 16.5			10 x 16.5		
Ground Engaging Type		Holes Only	Bolt-on Edge	Bolt-on Teeth	Holes Only	Bolt-on Edge	Bolt-on Teeth	Holes Only	Bolt-on Edge	
Bucket Assembly No.		165-6152	152-0224	152-0223	165-6153	152-0226	152-0225	154-5004	154-5045	
Rated bucket capacity	m ³	0.36	0.37	0.36	0.40	0.40	0.41	0.30	0.31	
	yd ³	0.47	0.48	0.47	0.52	0.52	0.53	0.39	0.41	
Struck capacity	m ³	0.26	0.27	0.26	0.29	0.29	0.29	0.22	0.22	
	yd ³	0.34	0.35	0.34	0.38	0.38	0.38	0.29	0.29	
Width	mm	1576	1586	1576	1730	1740	1730	1595	1595	
	in	62	62	62	68	68	68	63	63	
Dump clearance at maximum lift/dump	mm	2133	2103	2069	2130	2100	2066	2122	2092	
	in	84	83	81	84	83	81	84	82	
Reach at maximum lift/dump	mm	546	557	620	549	560	623	560	571	
	in	21	22	24	22	22	25	22	22	
Floor angle at maximum lift/dump	degrees	39.9	39.9	39.9	40	40	40	40.2	40.2	
Floor angle at maximum lift/rack back	degrees	96.7	96.7	96.7	96.5	96.5	96.5	96.4	96.4	
Clearance at maximum lift/level bucket	mm	2658	2642	2657	2656	2640	2655	2655	2683	
	in	105	104	105	105	104	105	105	106	
Hinge pin height at maximum lift	mm	2849	2849	2849	2849	2849	2849	2849	2849	
	in	112	112	112	112	112	112	112	112	
Maximum overall height	mm	3762	3790	3860	3759	3787	3857	3746	3774	
	in	148	149	152	148	149	152	147	149	
Reach at level lift arm/bucket	mm	1333	1361	1431	1335	1363	1433	1346	1374	
	in	52	54	56	53	54	56	53	54	
Maximum floor angle at minimum lift	degrees	26.1	26.1	26.1	26	26	26	25.8	25.8	
Dig depth with level bucket	mm	0	16	1	0	16	1	0	15	
	in	0.0	0.6	0.0	0.0	0.6	0.0	0.0	0.6	
Overall length with bucket on ground	mm	3286	3314	3384	3286	3314	3384	3290	3318	
	in	129	130	133	129	130	133	130	131	
Front clearance circle radius (with bucket)	mm	1989	2016	2079	2021	2048	2110	1992	2020	
	in	78	79	82	80	81	83	78	80	
Tipping load	216B3	kg	1213	1158	1187	1194	1140	1171	1074	1031
		lb	2673	2554	2616	2631	2513	2582	2367	2272
	226B3	kg	1293	1238	1267	1274	1219	1251	1153	1109
		lb	2850	2729	2792	2808	2688	2759	2541	2445
Breakout force — lift	216B3	kg	1437	1389	1421	1424	1374	1408	1330	1286
		lb	3168	3062	3132	3140	3030	3104	2932	2835
	226B3	kg	1437	1389	1421	1424	1374	1408	1330	1286
		lb	3168	3062	3132	3140	3030	3104	2932	2835
Breakout force — tilt	216B3	kg	1700	1596	1681	1694	1590	1677	1631	1539
		lb	3747	3518	3705	3735	3506	3697	3596	3393
	226B3	kg	1700	1596	1681	1694	1590	1677	1631	1539
		lb	3747	3518	3705	3735	3506	3697	3596	3393
Operating weight	216B3	kg	2637	2667	2654	2654	2687	2670	2769	2798
		lb	5814	5880	5850	5851	5924	5887	6103	6169
	226B3	kg	2669	2699	2686	2686	2719	2702	2801	2830
		lb	5885	5951	5921	5922	5994	5958	6174	6240

Bucket Type	Multi-Purpose					Dirt				
Bucket Width	1520 mm (60")	1680 mm (66")			1520 mm (60")	1680 mm (66")				
Tire Size	10 x 16.5	10 x 16.5			10 x 16.5		10 x 16.5			
Ground Engaging Type	Bolt-on Teeth	Holes Only	Bolt-on Edge	Bolt-on Teeth	Holes Only	Bolt-on Edge	Holes Only	Bolt-on Edge		
Bucket Assembly No.	154-5046	154-5008	154-5047	154-5048	165-6156	152-0231	165-6157	152-0232		
Rated bucket capacity	m ³	0.30	0.33	0.33	0.34	0.34	0.35	0.37	0.38	
	yd ³	0.39	0.43	0.43	0.44	0.44	0.46	0.48	0.49	
Struck capacity	m ³	0.22	0.24	0.25	0.24	0.25	0.25	0.27	0.27	
	yd ³	0.29	0.31	0.33	0.31	0.33	0.33	0.35	0.35	
Width	mm	1595	1749	1749	1749	1576	1586	1730	1740	
	in	63	69	69	69	62	62	68	69	
Dump clearance at maximum lift/dump	mm	2058	2122	2092	2058	2169	2140	2169	2140	
	in	81	84	82	81	85	84	85	84	
Reach at maximum lift/dump	mm	634	560	571	634	505	520	505	520	
	in	25	22	22	25	20	20	20	20	
Floor angle at maximum lift/dump	degrees	40.2	40.2	40.2	40.2	39.9	39.9	39.9	39.9	
Floor angle at maximum lift/rack back	degrees	96.4	96.4	96.4	96.4	96.7	96.7	96.7	96.7	
Clearance at maximum lift/level bucket	mm	2654	2655	2683	2654	2661	2648	2661	2648	
	in	104	105	106	104	105	104	105	104	
Hinge pin height at maximum lift	mm	2849	2849	2849	2849	2849	2849	2849	2849	
	in	112	112	112	112	112	112	112	112	
Maximum overall height	mm	3844	3746	3774	3844	3709	3739	3709	3739	
	in	151	147	149	151	146	147	146	147	
Reach at level lift arm/bucket	mm	1444	1346	1374	1444	1280	1310	1280	1310	
	in	57	53	54	57	50	52	50	52	
Maximum floor angle at minimum lift	degrees	25.8	25.8	25.8	25.8	26.1	26.1	26.1	26.1	
Dig depth with level bucket	mm	1	0	16	1	0	16	0	16	
	in	0.0	0.0	0.6	0.0	0.0	0.6	0.0	0.6	
Overall length with bucket on ground	mm	3388	3290	3318	3388	3233	3263	3233	3263	
	in	133	130	131	133	127	128	127	128	
Front clearance circle radius (with bucket)	mm	2083	1992	2020	2113	1940	1970	1970	2000	
	in	82	78	80	83	76	78	78	79	
Tipping load	216B3	kg	1058	1053	1001	1032	1304	1251	1280	1223
		lb	2332	2321	2207	2275	2875	2758	2823	2696
	226B3	kg	1137	1132	1079	1111	1386	1332	1363	1304
		lb	2506	2495	2379	2449	3056	2937	3004	2875
Breakout force — lift	216B3	kg	1316	1314	1265	1298	1515	1466	1495	1444
		lb	2900	2896	2789	2860	3339	3232	3295	3183
	226B3	kg	1316	1314	1265	1298	1515	1466	1495	1444
		lb	2900	2896	2789	2860	3339	3232	3295	3183
Breakout force — tilt	216B3	kg	1620	1618	1518	1601	1853	1740	1842	1727
		lb	3571	3568	3346	3529	4084	3835	4061	3807
	226B3	kg	1620	1618	1518	1601	1853	1740	1842	1727
		lb	3571	3568	3346	3529	4084	3835	4061	3807
Operating weight	216B3	kg	2785	2787	2820	2803	2579	2609	2604	2637
		lb	6139	6144	6216	6180	5685	5751	5740	5813
	226B3	kg	2817	2819	2852	2835	2611	2641	2636	2669
		lb	6210	6215	6287	6251	5756	5822	5811	5883

Work Tool			Pallet Fork			
Tine Length			910 mm (36")	1070 mm (42")	1220 mm (48")	
Tire Size			10 x 16.5	10 x 16.5	10 x 16.5	
Carriage Assembly No.			353-1694	353-1696	353-1697	
Carriage overall width without step		mm	1157	1157	1157	
		in	45	45	45	
Carriage step additional width		mm	108	108	108	
		in	4.25	4.25	4.25	
Carriage height above blade top		mm	923.5	923.5	923.5	
		in	36.4	36.4	36.4	
Blade surface height at maximum height		mm	2741	2741	2741	
		in	107.9	107.9	107.9	
Shank front face reach at maximum height		mm	290	290	290	
		in	11.4	11.4	11.4	
Blade surface height at level lift arms		mm	1383	1383	1383	
		in	54.4	54.4	54.4	
Shank front face reach at level lift arms		mm	743	743	743	
		in	29.3	29.3	29.3	
Blade surface height at minimum lift		mm	91	91	91	
		in	3.6	3.6	3.6	
Shank front face reach at minimum lift		mm	345	345	345	
		in	13.6	13.6	13.6	
Overall length at minimum lift, level tine		mm	3602	3762	3912	
		in	141.8	148.1	154.0	
Tipping load	216B3	kg	949	894	846	
		lb	2093	1970	1864	
	226B3	kg	1012	953	903	
		lb	2230	2102	1990	
	Operating weight	216B3	kg	2620	2630	2640
			lb	5775	5798	5820
226B3		kg	2652	2662	2672	
		lb	5846	5869	5890	

Bucket Type		General Purpose: Bolt-on Edge		
		1520 mm (60")	1680 mm (66")	1830 mm (72")
Bucket Width		1520 mm (60")	1680 mm (66")	1830 mm (72")
Tire Size		10 x 16.5	10 x 16.5	10 x 16.5
Ground Engaging Type		Bolt-on Edge	Bolt-on Edge	Bolt-on Edge
Bucket Assembly No.		279-5365	279-5369	279-5373
Rated bucket capacity	m ³	0.36	0.40	0.44
	yd ³	0.47	0.52	0.58
Struck capacity	m ³	0.27	0.29	0.31
	yd ³	0.35	0.38	0.41
Width	mm	1586	1740	1893
	in	62.4	68.5	74.5
Dump clearance at maximum lift/dump	mm	2003	2000	1999
	in	78.9	78.7	78.7
Reach at maximum lift/dump	mm	577	579	580
	in	22.7	22.8	22.8
Floor angle at maximum lift/dump	degrees	-46.8	-46.9	-46.9
Floor angle at maximum lift/rack back	degrees	88.8	88.7	88.7
Clearance at maximum lift/level bucket	mm	2607	2614	2613
	in	102.6	102.9	102.9
Hinge pin height at maximum lift	mm	2818	2816	2815
	in	110.9	110.9	110.8
Maximum overall height	mm	3731	3729	3728
	in	146.9	146.8	146.8
Reach at level lift arm/bucket	mm	1371	1374	1374
	in	54.0	54.1	54.1
Maximum floor angle at minimum lift	degrees	26.6	26.5	26.4
Dig depth with level bucket	mm	2	9	8
	in	0.1	0.4	0.3
Overall length with bucket on ground	mm	3317	3319	3319
	in	130.6	130.7	130.7
Front clearance circle radius (with bucket)	mm	2049	2080	2114
	in	80.7	81.9	83.2
Tipping load	kg	1299.1	1247.7	1230.7
	lb	2864	2751	2713
Breakout force — lift	kg	1438.2	1396.7	1383.6
	lb	3171	3079	3050
Breakout force — tilt	kg	1442.4	1408.8	1397.2
	lb	3180	3106	3080
Operating weight	kg	2625.8	2677.2	2692.7
	lb	5789	5902	5936

Bucket Type		Multi-Purpose: Bolt-on Edge		
Bucket Width		1520 mm (60")	1680 mm (66")	1830 mm (72")
Tire Size		10 x 16.5	10 x 16.5	10 x 16.5
Ground Engaging Type		Bolt-on Edge	Bolt-on Edge	Bolt-on Edge
Bucket Assembly No.		279-5381	279-5391	279-5399
Rated bucket capacity	m ³	0.30	0.34	0.37
	yd ³	0.39	0.44	0.48
Struck capacity	m ³	0.22	0.25	0.26
	yd ³	0.29	0.33	0.34
Width	mm	1595	1749	1902
	in	62.8	68.9	74.9
Dump clearance at maximum lift/dump	mm	1986	1985	1983
	in	78.2	78.1	78.1
Reach at maximum lift/dump	mm	588	590	591
	in	23.2	23.2	23.3
Floor angle at maximum lift/dump	degrees	-47.1	-47.2	-47.2
Floor angle at maximum lift/rack back	degrees	88.6	88.5	88.5
Clearance at maximum lift/level bucket	mm	2602	2600	2598
	in	102.5	102.4	102.3
Hinge pin height at maximum lift	mm	2808	2811	2810
	in	110.5	110.7	110.6
Maximum overall height	mm	3732	3731	3730
	in	146.9	146.9	146.8
Reach at level lift arm/bucket	mm	1385	1387	1388
	in	54.5	54.6	54.6
Maximum floor angle at minimum lift	degrees	26.3	26.2	26.2
Dig depth with level bucket	mm	-2	-4	-5
	in	-0.1	-0.1	-0.2
Overall length with bucket on ground	mm	3325	3324	3324
	in	130.9	130.9	130.9
Front clearance circle radius (with bucket)	mm	2058	2089	2123
	in	81.0	82.3	83.6
Tipping load	kg	1138.0	1106.9	1085.1
	lb	2509	2440	2392
Breakout force — lift	kg	1310.4	1288.7	1270.5
	lb	2889	2841	2801
Breakout force — tilt	kg	1344.3	1321.1	1306.7
	lb	2964	2912	2881
Operating weight	kg	2788.1	2810.6	2833.4
	lb	6147	6196	6246

Bucket Type		Dirt: Bolt-on Edge		
Bucket Width		1520 mm (60")	1680 mm (66")	1830 mm (72")
Tire Size		10 x 16.5	10 x 16.5	10 x 16.5
Ground Engaging Type		Bolt-on Edge	Bolt-on Edge	Bolt-on Edge
Bucket Assembly No.		279-5438	279-5441	285-6090
Rated bucket capacity	m ³	0.34	0.37	0.41
	yd ³	0.44	0.48	0.54
Struck capacity	m ³	0.25	0.27	0.30
	yd ³	0.33	0.35	0.39
Width	mm	1586	1740	1893
	in	62.4	68.5	74.5
Dump clearance at maximum lift/dump	mm	2043	2042	2041
	in	80.4	80.4	80.3
Reach at maximum lift/dump	mm	542	544	545
	in	21.4	21.4	21.4
Floor angle at maximum lift/dump	degrees	-46.8	-46.9	-46.9
Floor angle at maximum lift/rack back	degrees	88.8	88.8	88.8
Clearance at maximum lift/level bucket	mm	2620	2618	2616
	in	103.1	103.1	103.0
Hinge pin height at maximum lift	mm	2815	2817	2816
	in	110.8	110.9	110.9
Maximum overall height	mm	3678	3677	3676
	in	144.8	144.8	144.7
Reach at level lift arm/bucket	mm	1318	1320	1320
	in	51.9	52.0	52.0
Maximum floor angle at minimum lift	degrees	26.6	26.5	26.5
Dig depth with level bucket	mm	15	13	12
	in	0.6	0.5	0.5
Overall length with bucket on ground	mm	3267	3266	3266
	in	128.6	128.6	128.6
Front clearance circle radius (with bucket)	mm	2004	2036	2070
	in	78.9	80.2	81.5
Tipping load	kg	1331.9	1304.6	1287.8
	lb	2936	2876	2839
Breakout force — lift	kg	1463.7	1441.2	1427.5
	lb	3227	3177	3147
Breakout force — tilt	kg	1560.9	1486.2	1473.9
	lb	3441	3276	3249
Operating weight	kg	2626.8	2654.5	2670.6
	lb	5791	5852	5888

Work Tool	Pallet Fork		
	910 mm (36")	1070 mm (42")	1220 mm (48")
Tine Length	910 mm (36")	1070 mm (42")	1220 mm (48")
Tire Size	10 x 16.5	10 x 16.5	10 x 16.5
Carriage Assembly No.	353-1694	353-1696	353-1697
Carriage overall width without step	mm	1160	1160
	in	45.7	45.7
Carriage step additional width	mm	106	106
	in	4.2	4.2
Carriage height above blade top	mm	926	926
	in	36.5	36.5
Blade surface height at maximum height	mm	2722	2723
	in	107.2	107.2
Shank front face reach at maximum height	mm	400	401
	in	15.7	15.8
Blade surface height at level lift arms	mm	1433	1433
	in	56.4	56.4
Shank front face reach at level lift arms	mm	749	749
	in	29.5	29.5
Blade surface height at minimum lift	mm	116	117
	in	4.6	4.6
Shank front face reach at minimum lift	mm	363	363
	in	14.3	14.3
Overall length at minimum lift, level tine	mm	3610	3769
	in	142.1	148.4
Tipping load	kg	1044.6	984.7
	lb	2303	2171
Operating weight	kg	2598.6	2608.9
	lb	5729	5752

Bucket Type		General Purpose: Bolt-on Edge		
Bucket Width		1520 mm (60")	1680 mm (66")	1830 mm (72")
Tire Size		10 x 16.5	10 x 16.5	10 x 16.5
Ground Engaging Type		Bolt-on Edge	Bolt-on Edge	Bolt-on Edge
Bucket Assembly No.		279-5365	279-5369	279-5373
Rated bucket capacity	m ³	0.36	0.40	0.44
	yd ³	0.47	0.52	0.58
Struck capacity	m ³	0.27	0.29	0.31
	yd ³	0.35	0.38	0.41
Width	mm	1586	1740	1893
	in	62.4	68.5	74.5
Dump clearance at maximum lift/dump	mm	2179	2175	2174
	in	85.8	85.6	85.6
Reach at maximum lift/dump	mm	697	700	701
	in	27.4	27.6	27.6
Floor angle at maximum lift/dump	degrees	-47.5	-47.6	-47.6
Floor angle at maximum lift/rack back	degrees	88.2	88.1	88.0
Clearance at maximum lift/level bucket	mm	2803	2798	2796
	in	110.3	110.1	110.1
Hinge pin height at maximum lift	mm	2999	2997	2996
	in	118.1	118.0	118.0
Maximum overall height	mm	3910	3907	3906
	in	153.9	153.8	153.8
Reach at level lift arm/bucket	mm	1332	1335	1336
	in	52.5	52.6	52.6
Maximum floor angle at minimum lift	degrees	26.9	26.8	26.8
Dig depth with level bucket	mm	17	14	12
	in	0.7	0.5	0.5
Overall length with bucket on ground	mm	3321	3320	3320
	in	130.7	130.7	130.7
Front clearance circle radius (with bucket)	mm	2045	2077	2110
	in	80.5	81.8	83.1
Tipping load	kg	1571.5	1520.7	1503.8
	lb	3465	3353	3315
Breakout force — lift	kg	1647.1	1605.4	1592.2
	lb	3631	3539	3510
Breakout force — tilt	kg	1584.3	1561.6	1552.5
	lb	3493	3443	3423
Operating weight	kg	2856.3	2907.7	2923.2
	lb	6297	6410	6444

Bucket Type		Multi-Purpose: Bolt-on Edge		
Bucket Width		1520 mm (60")	1680 mm (66")	1830 mm (72")
Tire Size		10 x 16.5	10 x 16.5	10 x 16.5
Ground Engaging Type		Bolt-on Edge	Bolt-on Edge	Bolt-on Edge
Bucket Assembly No.		279-5381	279-5391	279-5399
Rated bucket capacity	m ³	0.30	0.34	0.37
	yd ³	0.39	0.44	0.48
Struck capacity	m ³	0.22	0.25	0.26
	yd ³	0.29	0.33	0.34
Width	mm	1595	1749	1902
	in	62.8	68.9	74.9
Dump clearance at maximum lift/dump	mm	2160	2159	2157
	in	85.0	85.0	84.9
Reach at maximum lift/dump	mm	710	712	714
	in	28.0	28.0	28.1
Floor angle at maximum lift/dump	degrees	-47.8	-47.9	-47.9
Floor angle at maximum lift/rack back	degrees	87.9	87.8	87.8
Clearance at maximum lift/level bucket	mm	2785	2782	2780
	in	109.6	109.5	109.4
Hinge pin height at maximum lift	mm	2992	2991	2990
	in	117.8	117.8	117.7
Maximum overall height	mm	3909	3908	3906
	in	153.9	153.8	153.8
Reach at level lift arm/bucket	mm	1347	1349	1350
	in	53.0	53.1	53.2
Maximum floor angle at minimum lift	degrees	26.6	26.6	25.5
Dig depth with level bucket	mm	3	0	-1
	in	0.1	0.0	-0.1
Overall length with bucket on ground	mm	3326	3325	3325
	in	130.9	130.9	130.9
Front clearance circle radius (with bucket)	mm	2054	2086	2119
	in	80.9	82.1	83.4
Tipping load	kg	1408.2	1377.4	1355.6
	lb	3105	3037	2988
Breakout force — lift	kg	1518.6	1497.0	1478.7
	lb	3348	3300	3260
Breakout force — tilt	kg	1524.3	1501.8	1492.5
	lb	3360	3311	3290
Operating weight	kg	3018.6	3041.1	3063.9
	lb	6655	6704	6755

Bucket Type		Dirt: Bolt-on Edge		
Bucket Width		1520 mm (60")	1680 mm (66")	1830 mm (72")
Tire Size		10 x 16.5	10 x 16.5	10 x 16.5
Ground Engaging Type		Bolt-on Edge	Bolt-on Edge	Bolt-on Edge
Bucket Assembly No.		279-5438	279-5441	285-6090
Rated bucket capacity	m ³	0.34	0.37	0.41
	yd ³	0.44	0.48	0.54
Struck capacity	m ³	0.25	0.27	0.30
	yd ³	0.33	0.35	0.39
Width	mm	1586	1740	1893
	in	62.4	68.5	74.5
Dump clearance at maximum lift/dump	mm	2220	2218	2217
	in	87.4	87.3	87.3
Reach at maximum lift/dump	mm	663	665	666
	in	26.1	26.2	26.2
Floor angle at maximum lift/dump	degrees	-47.5	-47.5	-47.6
Floor angle at maximum lift/rack back	degrees	88.2	88.1	88.1
Clearance at maximum lift/level bucket	mm	2804	2802	2800
	in	110.4	110.3	110.2
Hinge pin height at maximum lift	mm	2999	2998	2997
	in	118.1	118.0	118.0
Maximum overall height	mm	3857	3856	3855
	in	151.9	151.8	151.8
Reach at level lift arm/bucket	mm	1279	1281	1282
	in	50.4	50.4	50.5
Maximum floor angle at minimum lift	degrees	26.9	26.9	26.8
Dig depth with level bucket	mm	19	17	16
	in	0.7	0.7	0.6
Overall length with bucket on ground	mm	3268	3268	3267
	in	128.7	128.6	128.6
Front clearance circle radius (with bucket)	mm	2000	2033	2067
	in	78.8	80.0	81.4
Tipping load	kg	1610.6	1583.5	1567.0
	lb	3551	3491	3454
Breakout force — lift	kg	1675.6	1653.1	1639.3
	lb	3694	3644	3614
Breakout force — tilt	kg	1692.5	1680.7	1671.1
	lb	3731	3705	3684
Operating weight	kg	2857.3	2885.0	2901.1
	lb	6299	6360	6396

Work Tool	Pallet Fork			
		910 mm (36")	1070 mm (42")	1220 mm (48")
Tine Length		910 mm (36")	1070 mm (42")	1220 mm (48")
Tire Size		10 x 16.5	10 x 16.5	10 x 16.5
Carriage Assembly No.		353-1694	353-1696	353-1697
Carriage overall width without step	mm	1160	1160	1160
	in	45.7	45.7	45.7
Carriage step additional width	mm	106	106	106
	in	4.2	4.2	4.2
Carriage height above blade top	mm	926	926	926
	in	36.5	36.5	36.5
Blade surface height at maximum height	mm	2908	2910	2910
	in	114.5	114.6	114.6
Shank front face reach at maximum height	mm	530	531	533
	in	20.8	20.9	21.0
Blade surface height at level lift arms	mm	1588	1589	1589
	in	62.5	62.6	62.6
Shank front face reach at level lift arms	mm	709	710	711
	in	27.9	27.9	28.0
Blade surface height at minimum lift	mm	122	124	124
	in	4.8	4.9	4.9
Shank front face reach at minimum lift	mm	363	363	364
	in	14.3	14.3	14.3
Overall length at minimum lift, level tine	mm	3610	3770	3920
	in	142.1	148.4	154.3
Tipping load	kg	1262.7	1192.6	1131.9
	lb	2784	2629	2495
Operating weight	kg	2829.1	2839.4	2849.0
	lb	6237	6260	6281

Bucket Type		General Purpose: Bolt-on Edge		
		1520 mm (60")	1680 mm (66")	1830 mm (72")
Bucket Width		1520 mm (60")	1680 mm (66")	1830 mm (72")
Tire Size		10 x 16.5	10 x 16.5	10 x 16.5
Ground Engaging Type		Bolt-on Edge	Bolt-on Edge	Bolt-on Edge
Bucket Assembly No.		279-5365	279-5369	279-5373
Rated bucket capacity	m ³	0.36	0.40	0.44
	yd ³	0.47	0.52	0.58
Struck capacity	m ³	0.27	0.29	0.31
	yd ³	0.35	0.38	0.41
Width	mm	1586	1740	1893
	in	62.4	68.5	74.5
Dump clearance at maximum lift/dump	mm	2295	2293	2292
	in	90.4	90.3	90.2
Reach at maximum lift/dump	mm	407	410	410
	in	16.0	16.1	16.2
Floor angle at maximum lift/dump	degrees	-46.9	-47.0	-47.0
Floor angle at maximum lift/rack back	degrees	87.6	87.6	87.6
Clearance at maximum lift/level bucket	mm	2908	2906	2905
	in	114.5	114.4	114.4
Hinge pin height at maximum lift	mm	3120	3118	3118
	in	122.8	122.8	122.7
Maximum overall height	mm	4063	4061	4061
	in	160.0	159.9	159.9
Reach at level lift arm/bucket	mm	1419	1422	1423
	in	55.9	56.0	56.0
Maximum floor angle at minimum lift	degrees	23.4	23.4	23.4
Dig depth with level bucket	mm	-23	-25	-26
	in	-0.9	-1.0	-1.0
Overall length with bucket on ground	mm	3575	3575	3575
	in	140.8	140.8	140.8
Front clearance circle radius (with bucket)	mm	2229	2258	2288
	in	87.8	88.9	90.1
Tipping load	kg	1535.3	1483.8	1466.8
	lb	3385	3271	3234
Breakout force — lift	kg	1676.0	1641.4	1629.6
	lb	3695	3619	3593
Breakout force — tilt	kg	2040.2	2017.0	2007.9
	lb	4498	4447	4427
Operating weight	kg	2979.4	3030.8	3046.3
	lb	6568	6682	6716

Bucket Type		Multi-Purpose: Bolt-on Edge		
Bucket Width		1520 mm (60")	1680 mm (66")	1830 mm (72")
Tire Size		10 × 16.5	10 × 16.5	10 × 16.5
Ground Engaging Type		Bolt-on Edge	Bolt-on Edge	Bolt-on Edge
Bucket Assembly No.		279-5381	279-5391	279-5399
Rated bucket capacity	m ³	0.30	0.34	0.37
	yd ³	0.39	0.44	0.48
Struck capacity	m ³	0.22	0.25	0.26
	yd ³	0.29	0.33	0.34
Width	mm	1595	1749	1902
	in	62.8	68.9	74.9
Dump clearance at maximum lift/dump	mm	2280	2279	2278
	in	89.8	89.7	89.7
Reach at maximum lift/dump	mm	418	419	421
	in	16.5	16.5	16.6
Floor angle at maximum lift/dump	degrees	-47.2	-47.2	-47.3
Floor angle at maximum lift/rack back	degrees	87.7	87.8	87.8
Clearance at maximum lift/level bucket	mm	2899	2898	2897
	in	114.1	114.1	114.1
Hinge pin height at maximum lift	mm	3115	3114	3113
	in	122.6	122.6	122.6
Maximum overall height	mm	4065	4065	4064
	in	160.1	160.0	160.0
Reach at level lift arm/bucket	mm	1433	1435	1436
	in	56.4	56.5	56.5
Maximum floor angle at minimum lift	degrees	23.4	23.4	23.4
Dig depth with level bucket	mm	-32	-33	-34
	in	-1.3	-1.3	-1.3
Overall length with bucket on ground	mm	3575	3575	3575
	in	140.8	140.8	140.8
Front clearance circle radius (with bucket)	mm	2232	2261	2291
	in	87.9	89.0	90.2
Tipping load	kg	1370.7	1339.9	1317.8
	lb	3022	2954	2905
Breakout force — lift	kg	1574.2	1551.1	1536.2
	lb	3471	3419	3387
Breakout force — tilt	kg	1978.5	1956.1	1946.5
	lb	4362	4312	4291
Operating weight	kg	3141.7	3164.2	3187.0
	lb	6926	6976	7026

Bucket Type		Dirt: Bolt-on Edge		
Bucket Width		1520 mm (60")	1680 mm (66")	1830 mm (72")
Tire Size		10 x 16.5	10 x 16.5	10 x 16.5
Ground Engaging Type		Bolt-on Edge	Bolt-on Edge	Bolt-on Edge
Bucket Assembly No.		279-5438	279-5441	285-6090
Rated bucket capacity	m ³	0.34	0.37	0.41
	yd ³	0.44	0.48	0.54
Struck capacity	m ³	0.25	0.27	0.30
	yd ³	0.33	0.35	0.39
Width	mm	1586	1740	1893
	in	62.4	68.5	74.5
Dump clearance at maximum lift/dump	mm	2335	2334	2334
	in	91.9	91.9	91.9
Reach at maximum lift/dump	mm	373	374	375
	in	14.7	14.7	14.8
Floor angle at maximum lift/dump	degrees	-46.9	-47.0	-47.0
Floor angle at maximum lift/rack back	degrees	87.6	87.6	87.6
Clearance at maximum lift/level bucket	mm	2911	2910	2909
	in	114.6	114.6	114.5
Hinge pin height at maximum lift	mm	3120	3119	3119
	in	122.8	122.8	122.8
Maximum overall height	mm	4010	4009	4008
	in	157.9	157.8	157.8
Reach at level lift arm/bucket	mm	1367	1368	1369
	in	53.8	53.8	53.9
Maximum floor angle at minimum lift	degrees	23.4	23.4	23.4
Dig depth with level bucket	mm	-21	-22	-22
	in	-0.8	-0.9	-0.9
Overall length with bucket on ground	mm	3575	3575	3575
	in	140.8	140.8	140.8
Front clearance circle radius (with bucket)	mm	2182	2211	1228
	in	85.9	87.1	48.4
Tipping load	kg	1572.8	1545.3	1528.6
	lb	3467	3407	3370
Breakout force — lift	kg	1743.7	1725.0	1712.5
	lb	3844	3803	3775
Breakout force — tilt	kg	2177.0	2164.9	2155.2
	lb	4799	4773	4751
Operating weight	kg	2980.4	3008.1	3024.2
	lb	6571	6632	6667

Work Tool		Pallet Fork		
Tine Length		910 mm (36")	1070 mm (42")	1220 mm (48")
Tire Size		10 x 16.5	10 x 16.5	10 x 16.5
Carriage Assembly No.		353-1694	353-1696	353-1697
Carriage overall width without step	mm	1160	1160	1160
	in	45.7	45.7	45.7
Carriage step additional width	mm	106	106	106
	in	4.2	4.2	4.2
Carriage height above blade top	mm	926	926	926
	in	36.5	36.5	36.5
Blade surface height at maximum height	mm	3020	3021	3022
	in	118.9	119.0	119.0
Shank front face reach at maximum height	mm	235	237	239
	in	9.3	9.3	9.4
Blade surface height at level lift arms	mm	1387	1386	1384
	in	54.6	54.6	54.5
Shank front face reach at level lift arms	mm	800	800	802
	in	31.5	31.5	31.6
Blade surface height at minimum lift	mm	78	79	78
	in	3.1	3.1	3.1
Shank front face reach at minimum lift	mm	437	437	437
	in	17.2	17.2	17.2
Overall length at minimum lift, level tine	mm	3861	4021	4171
	in	152.0	158.3	164.2
Tipping load	kg	1237.9	1171.0	1112.8
	lb	2729	2582	2453
Operating weight	kg	2952.2	2962.5	2972.1
	lb	6508	6531	6552

Bucket Type		General Purpose: Bolt-on Edge		
Bucket Width		1520 mm (60")	1680 mm (66")	1830 mm (72")
Tire Size		12 x 16.5	12 x 16.5	12 x 16.5
Ground Engaging Type		Bolt-on Edge	Bolt-on Edge	Bolt-on Edge
Bucket Assembly No.		279-5365	279-5369	279-5373
Rated bucket capacity	m ³	0.36	0.40	0.44
	yd ³	0.47	0.52	0.58
Struck capacity	m ³	0.27	0.29	0.31
	yd ³	0.35	0.38	0.41
Width	mm	1586	1740	1893
	in	62.4	68.5	74.5
Dump clearance at maximum lift/dump	mm	2218	2215	2215
	in	87.3	87.2	87.2
Reach at maximum lift/dump	mm	558	561	561
	in	22.0	22.1	22.1
Floor angle at maximum lift/dump	degrees	-51.3	-51.4	-51.4
Floor angle at maximum lift/rack back	degrees	88.0	87.9	87.9
Clearance at maximum lift/level bucket	mm	2866	2863	2863
	in	112.8	112.7	112.7
Hinge pin height at maximum lift	mm	3077	3076	3075
	in	121.1	121.1	121.1
Maximum overall height	mm	4004	4002	4001
	in	157.6	157.6	157.5
Reach at level lift arm/bucket	mm	1316	1318	1318
	in	51.8	51.9	51.9
Maximum floor angle at minimum lift	degrees	23.0	23.0	23.0
Dig depth with level bucket	mm	-12	-13	-14
	in	-0.5	-0.5	-0.5
Overall length with bucket on ground	mm	3564	3564	3564
	in	140.3	140.3	140.3
Front clearance circle radius (with bucket)	mm	2341	2383	2426
	in	92.2	93.8	95.5
Tipping load	kg	1873.9	1823.0	1806.0
	lb	4131	4019	3981
Breakout force — lift	kg	1852.8	1818.3	1806.5
	lb	4085	4009	3983
Breakout force — tilt	kg	2023.8	2000.6	1991.5
	lb	4462	4411	4390
Operating weight	kg	3170.3	3221.7	3237.2
	lb	6989	7103	7137

Bucket Type		Multi-Purpose: Bolt-on Edge		
Bucket Width		1520 mm (60")	1680 mm (66")	1830 mm (72")
Tire Size		12 x 16.5	12 x 16.5	12 x 16.5
Ground Engaging Type		Bolt-on Edge	Bolt-on Edge	Bolt-on Edge
Bucket Assembly No.		279-5381	279-5391	279-5399
Rated bucket capacity	m ³	0.30	0.34	0.37
	yd ³	0.39	0.44	0.48
Struck capacity	m ³	0.22	0.25	0.26
	yd ³	0.29	0.33	0.34
Width	mm	1595	1749	1902
	in	62.8	68.9	74.9
Dump clearance at maximum lift/dump	mm	2203	2202	2201
	in	86.7	86.7	86.6
Reach at maximum lift/dump	mm	568	569	570
	in	22.3	22.4	22.4
Floor angle at maximum lift/dump	degrees	-51.6	-51.6	-51.6
Floor angle at maximum lift/rack back	degrees	87.8	87.8	87.7
Clearance at maximum lift/level bucket	mm	2856	2855	2854
	in	112.5	112.4	112.4
Hinge pin height at maximum lift	mm	3072	3071	3070
	in	120.9	120.9	120.9
Maximum overall height	mm	4005	4004	4004
	in	157.7	157.7	157.6
Reach at level lift arm/bucket	mm	1328	1329	1330
	in	52.3	52.3	52.4
Maximum floor angle at minimum lift	degrees	23.0	23.0	23.0
Dig depth with level bucket	mm	-20	-20	-21
	in	-0.8	-0.8	-0.8
Overall length with bucket on ground	mm	3571	3571	3570
	in	140.6	140.6	140.6
Front clearance circle radius (with bucket)	mm	2344	2386	2428
	in	92.3	93.9	95.6
Tipping load	kg	1706.2	1675.2	1653.1
	lb	3762	3693	3644
Breakout force — lift	kg	1751.5	1728.3	1713.4
	lb	3861	3810	3777
Breakout force — tilt	kg	1962.1	1939.7	1930.1
	lb	4326	4276	4255
Operating weight	kg	3332.6	3355.1	3377.9
	lb	7347	7397	7447

Bucket Type		Dirt: Bolt-on Edge		
Bucket Width		1520 mm (60")	1680 mm (66")	1830 mm (72")
Tire Size		12 x 16.5	12 x 16.5	12 x 16.5
Ground Engaging Type		Bolt-on Edge	Bolt-on Edge	Bolt-on Edge
Bucket Assembly No.		279-5438	279-5441	285-6090
Rated bucket capacity	m ³	0.34	0.37	0.41
	yd ³	0.44	0.48	0.54
Struck capacity	m ³	0.25	0.27	0.30
	yd ³	0.33	0.35	0.39
Width	mm	1586	1740	1893
	in	62.4	68.5	74.5
Dump clearance at maximum lift/dump	mm	2260	2259	2259
	in	89.0	88.9	88.9
Reach at maximum lift/dump	mm	527	529	529
	in	20.8	20.8	20.8
Floor angle at maximum lift/dump	degrees	-51.3	-51.4	-51.4
Floor angle at maximum lift/rack back	degrees	88.0	87.9	87.9
Clearance at maximum lift/level bucket	mm	2868	2867	2866
	in	112.9	112.9	112.8
Hinge pin height at maximum lift	mm	3077	3076	3076
	in	121.1	121.1	121.1
Maximum overall height	mm	3951	3950	3949
	in	155.5	155.5	155.5
Reach at level lift arm/bucket	mm	1263	1264	1265
	in	49.7	49.8	49.8
Maximum floor angle at minimum lift	degrees	23.0	23.0	23.0
Dig depth with level bucket	mm	-10	-10	-11
	in	-0.4	-0.4	-0.4
Overall length with bucket on ground	mm	3511	3511	3511
	in	138.2	138.2	138.2
Front clearance circle radius (with bucket)	mm	2299	2341	2385
	in	90.5	92.2	93.9
Tipping load	kg	1921.9	1894.6	1878.2
	lb	4237	4177	4141
Breakout force — lift	kg	1928.3	1909.7	1897.2
	lb	4251	4210	4183
Breakout force — tilt	kg	2159.5	2147.4	2137.7
	lb	4761	4734	4713
Operating weight	kg	3171.3	3199.0	3215.1
	lb	6991	7053	7088

Work Tool	Pallet Fork		
Tine Length	910 mm (36")	1070 mm (42")	1220 mm (48")
Tire Size	12 x 16.5	12 x 16.5	12 x 16.5
Carriage Assembly No.	353-1694	353-1696	353-1697
Carriage overall width without step	mm	1160	1160
	in	45.7	45.7
Carriage step additional width	mm	106	106
	in	4.2	4.2
Carriage height above blade top	mm	926	926
	in	36.5	36.5
Blade surface height at maximum height	mm	2970	2970
	in	116.9	116.9
Shank front face reach at maximum height	mm	452	453
	in	17.8	17.8
Blade surface height at level lift arms	mm	1384	1384
	in	54.5	54.5
Shank front face reach at level lift arms	mm	695	696
	in	27.4	27.4
Blade surface height at minimum lift	mm	88	88
	in	3.5	3.5
Shank front face reach at minimum lift	mm	399	399
	in	15.7	15.7
Overall length at minimum lift, level tine	mm	3851	4011
	in	151.6	157.9
Tipping load	kg	1489.6	1408.7
	lb	3284	3106
Operating weight	kg	3143.1	3153.4
	lb	6929	6952
			3163.0
			6973

Bucket Type		General Purpose: Bolt-on Edge			
Bucket Width		1680 mm (66")	1830 mm (72")	1981 mm (78")	2134 mm (84")
Tire Size		12 x 16.5	12 x 16.5	12 x 16.5	12 x 16.5
Ground Engaging Type		Bolt-on Edge	Bolt-on Edge	Bolt-on Edge	Bolt-on Edge
Bucket Assembly No.		279-5369	279-5373	279-5377	296-8192
Rated bucket capacity	m ³	0.40	0.44	0.48	0.63
	yd ³	0.52	0.58	0.63	0.82
Struck capacity	m ³	0.29	0.31	0.32	0.59
	yd ³	0.38	0.41	0.42	0.77
Width	mm	1740	1893	2045	2198
	in	68.5	74.5	80.5	86.5
Dump clearance at maximum lift/dump	mm	2405	2404	2404	2343
	in	94.7	94.7	94.6	92.3
Reach at maximum lift/dump	mm	625	626	626	700
	in	24.6	24.6	24.7	27.6
Floor angle at maximum lift/dump	degrees	-37.9	-38.0	-38.0	-38.0
Floor angle at maximum lift/rack back	degrees	97.1	97.1	97.1	97.0
Clearance at maximum lift/level bucket	mm	2940	2939	2939	2936
	in	115.7	115.7	115.7	115.6
Hinge pin height at maximum lift	mm	3150	3150	3150	3148
	in	124.0	124.0	124.0	124.0
Maximum overall height	mm	4114	4114	4113	4205
	in	162.0	162.0	161.9	165.6
Reach at level lift arm/bucket	mm	1468	1469	1469	1564
	in	57.8	57.8	57.8	61.6
Maximum floor angle at minimum lift	degrees	26.6	26.6	26.6	26.6
Dig depth with level bucket	mm	-14	-14	-15	-17
	in	-0.6	-0.6	-0.6	-0.7
Overall length with bucket on ground	mm	3792	3792	3792	3885
	in	149.3	149.3	149.3	153.0
Front clearance circle radius (with bucket)	mm	2259	2290	2322	2436
	in	88.9	90.1	91.4	95.9
Tipping load	kg	1871.4	1854.3	1839.8	1764.7
	lb	4126	4088	4056	3891
Breakout force — lift	kg	2089.4	2077.5	2069.4	1902.4
	lb	4606	4580	4562	4194
Breakout force — tilt	kg	2947.3	2938.1	2934.0	2612.4
	lb	6498	6477	6468	5759
Operating weight	kg	3423.1	3438.6	3452.9	3489.8
	lb	7547	7581	7612	7694

Bucket Type		Multi-Purpose: Bolt-on Edge		
Bucket Width		1680 mm (66")	1830 mm (72")	1981 mm (78")
Tire Size		12 x 16.5	12 x 16.5	12 x 16.5
Ground Engaging Type		Bolt-on Edge	Bolt-on Edge	Bolt-on Edge
Bucket Assembly No.		279-5391	279-5399	279-5402
Rated bucket capacity	m ³	0.34	0.37	0.40
	yd ³	0.44	0.48	0.52
Struck capacity	m ³	0.25	0.26	0.28
	yd ³	0.33	0.34	0.37
Width	mm	1749	1902	2045
	in	68.9	74.9	80.5
Dump clearance at maximum lift/dump	mm	2393	2392	2391
	in	94.2	94.2	94.1
Reach at maximum lift/dump	mm	634	635	636
	in	25.0	25.0	25.0
Floor angle at maximum lift/dump	degrees	-38.1	-38.1	-38.1
Floor angle at maximum lift/rack back	degrees	97.0	97.0	97.0
Clearance at maximum lift/level bucket	mm	2933	2932	2931
	in	115.5	115.4	115.4
Hinge pin height at maximum lift	mm	3147	3146	3146
	in	123.9	123.9	123.8
Maximum overall height	mm	4119	4118	4118
	in	162.2	162.1	162.1
Reach at level lift arm/bucket	mm	1479	1480	1481
	in	58.2	58.3	58.3
Maximum floor angle at minimum lift	degrees	26.6	26.6	26.6
Dig depth with level bucket	mm	-21	-21	-22
	in	-0.8	-0.8	-0.8
Overall length with bucket on ground	mm	3798	3798	3798
	in	149.5	149.5	149.5
Front clearance circle radius (with bucket)	mm	2262	2292	2325
	in	89.1	90.2	91.5
Tipping load	kg	1722.8	1700.4	1687.8
	lb	3798	3749	3721
Breakout force — lift	kg	1998.7	1983.7	1968.9
	lb	4406	4373	4341
Breakout force — tilt	kg	2885.5	2875.8	2864.7
	lb	6361	6340	6315
Operating weight	kg	3556.5	3579.3	3599.2
	lb	7841	7891	7935

Bucket Type		Dirt: Bolt-on Edge		
Bucket Width		1680 mm (66")	1830 mm (72")	1981 mm (78")
Tire Size		12 x 16.5	12 x 16.5	12 x 16.5
Ground Engaging Type		Bolt-on Edge	Bolt-on Edge	Bolt-on Edge
Bucket Assembly No.		279-5441	285-6090	268-4083
Rated bucket capacity	m ³	0.37	0.41	0.44
	yd ³	0.48	0.54	0.58
Struck capacity	m ³	0.27	0.30	0.32
	yd ³	0.35	0.39	0.42
Width	mm	1740	1893	2045
	in	68.5	74.5	80.5
Dump clearance at maximum lift/dump	mm	2440	2440	2439
	in	96.1	96.0	96.0
Reach at maximum lift/dump	mm	584	585	585
	in	23.0	23.0	23.0
Floor angle at maximum lift/dump	degrees	-37.9	-37.9	-38.0
Floor angle at maximum lift/rack back	degrees	97.1	97.1	97.1
Clearance at maximum lift/level bucket	mm	2943	2942	2942
	in	115.9	115.8	115.8
Hinge pin height at maximum lift	mm	3151	3150	3150
	in	124.1	124.0	124.0
Maximum overall height	mm	4062	4061	4061
	in	159.9	159.9	159.9
Reach at level lift arm/bucket	mm	1415	1415	1416
	in	55.7	55.7	55.7
Maximum floor angle at minimum lift	degrees	26.6	26.6	26.6
Dig depth with level bucket	mm	-11	-12	-12
	in	-0.4	-0.5	-0.5
Overall length with bucket on ground	mm	3739	3739	3739
	in	147.2	147.2	147.2
Front clearance circle radius (with bucket)	mm	2212	2244	2277
	in	87.1	88.3	89.6
Tipping load	kg	1940.5	1923.9	1908.4
	lb	4278	4241	4207
Breakout force — lift	kg	2190.6	2178.0	2168.2
	lb	4829	4802	4780
Breakout force — tilt	kg	3155.3	2302.8	3140.8
	lb	6956	5077	6924
Operating weight	kg	3400.4	3416.5	3433.8
	lb	7496	7532	7570

Work Tool	Pallet Fork			
		910 mm (36")	1070 mm (42")	1220 mm (48")
Tine Length		910 mm (36")	1070 mm (42")	1220 mm (48")
Tire Size		12 x 16.5	12 x 16.5	12 x 16.5
Carriage Assembly No.		353-1694	353-1696	353-1697
Carriage overall width without step	mm	1160	1160	1160
	in	45.7	45.7	45.7
Carriage step additional width	mm	106	106	106
	in	4.2	4.2	4.2
Carriage height above blade top	mm	926	926	926
	in	36.5	36.5	36.5
Blade surface height at maximum height	mm	3043	3043	3042
	in	119.8	119.8	119.8
Shank front face reach at maximum height	mm	329	329	331
	in	12.9	13.0	13.0
Blade surface height at level lift arms	mm	1487	1486	1485
	in	58.5	58.5	58.5
Shank front face reach at level lift arms	mm	846	847	848
	in	33.3	33.3	33.4
Blade surface height at minimum lift	mm	91	91	90
	in	3.6	3.6	3.5
Shank front face reach at minimum lift	mm	421	421	421
	in	16.6	16.6	16.6
Overall length at minimum lift, level tine	mm	4078	4238	4388
	in	160.6	166.9	172.8
Tipping load	kg	1551.8	1473.4	1405.0
	lb	3421	3248	3098
Operating weight	kg	3344.5	3354.8	3364.4
	lb	7373	7396	7417

Bucket Type		General Purpose: Bolt-on Edge			
Bucket Width		1680 mm (66")	1830 mm (72")	1981 mm (78")	2134 mm (84")
Tire Size		12 x 16.5	12 x 16.5	12 x 16.5	12 x 16.5
Ground Engaging Type		Bolt-on Edge	Bolt-on Edge	Bolt-on Edge	Bolt-on Edge
Bucket Assembly No.		279-5369	279-5373	279-5377	296-8192
Rated bucket capacity	m ³	0.40	0.44	0.48	0.63
	yd ³	0.52	0.58	0.63	0.82
Struck capacity	m ³	0.29	0.31	0.32	0.59
	yd ³	0.38	0.41	0.42	0.77
Width	mm	1740	1893	2045	2198
	in	68.5	74.5	80.5	86.5
Dump clearance at maximum lift/dump	mm	2312	2312	2311	2236
	in	91.0	91.0	91.0	88.0
Reach at maximum lift/dump	mm	795	796	797	857
	in	31.3	31.3	31.4	33.7
Floor angle at maximum lift/dump	degrees	-50.3	-50.3	-50.3	-50.4
Floor angle at maximum lift/rack back	degrees	84.6	84.6	84.6	84.6
Clearance at maximum lift/level bucket	mm	2961	2960	2959	2955
	in	116.6	116.5	116.5	116.4
Hinge pin height at maximum lift	mm	3172	3171	3171	3169
	in	124.9	124.9	124.8	124.8
Maximum overall height	mm	4093	4092	4092	4183
	in	161.1	161.1	161.1	164.7
Reach at level lift arm/bucket	mm	1359	1359	1360	1455
	in	53.5	53.5	53.5	57.3
Maximum floor angle at minimum lift	degrees	26.6	26.6	26.6	26.6
Dig depth with level bucket	mm	-12	-12	-12	-15
	in	-0.5	-0.5	-0.5	-0.6
Overall length with bucket on ground	mm	3793	3793	3793	3886
	in	149.3	149.3	149.3	153.0
Front clearance circle radius (with bucket)	mm	2259	2290	2322	2436
	in	88.9	90.1	91.4	95.9
Tipping load	kg	2384.1	2366.9	2352.0	2265.3
	lb	5256	5218	5185	4994
Breakout force — lift	kg	2392.0	2378.7	2367.6	2211.6
	lb	5273	5244	5220	4876
Breakout force — tilt	kg	2947.7	2938.5	2934.4	2612.8
	lb	6499	6478	6469	5760
Operating weight	kg	3667.4	3682.9	3697.2	3734.1
	lb	8085	8119	8151	8232

Bucket Type		Multi-Purpose: Bolt-on Edge		
Bucket Width		1680 mm (66")	1830 mm (72")	1981 mm (78")
Tire Size		12 x 16.5	12 x 16.5	12 x 16.5
Ground Engaging Type		Bolt-on Edge	Bolt-on Edge	Bolt-on Edge
Bucket Assembly No.		279-5391	279-5399	279-5402
Rated bucket capacity	m ³	0.34	0.37	0.40
	yd ³	0.44	0.48	0.52
Struck capacity	m ³	0.25	0.26	0.28
	yd ³	0.33	0.34	0.37
Width	mm	1749	1902	2045
	in	68.9	74.9	80.5
Dump clearance at maximum lift/dump	mm	2298	2297	2296
	in	90.5	90.4	90.4
Reach at maximum lift/dump	mm	803	804	805
	in	31.6	31.7	31.7
Floor angle at maximum lift/dump	degrees	-50.5	-50.5	-50.5
Floor angle at maximum lift/rack back	degrees	84.5	84.5	84.4
Clearance at maximum lift/level bucket	mm	2952	2951	2950
	in	116.2	116.2	116.1
Hinge pin height at maximum lift	mm	3166	3166	3165
	in	124.7	124.6	124.6
Maximum overall height	mm	4095	4094	4093
	in	161.2	161.2	161.1
Reach at level lift arm/bucket	mm	1370	1371	1371
	in	53.9	54.0	54.0
Maximum floor angle at minimum lift	degrees	26.6	26.6	26.6
Dig depth with level bucket	mm	-18	-19	-19
	in	-0.7	-0.7	-0.8
Overall length with bucket on ground	mm	3799	3799	3799
	in	149.6	149.6	149.6
Front clearance circle radius (with bucket)	mm	2262	2292	2325
	in	89.1	90.2	91.5
Tipping load	kg	2228.5	2205.9	2196.5
	lb	4913	4863	4842
Breakout force — lift	kg	2282.1	2263.6	2246.7
	lb	5031	4990	4953
Breakout force — tilt	kg	2885.9	2876.2	2865.1
	lb	6362	6341	6316
Operating weight	kg	3800.8	3823.6	3843.5
	lb	8379	8430	8473

Bucket Type		Dirt: Bolt-on Edge		
Bucket Width		1680 mm (66")	1830 mm (72")	1981 mm (78")
Tire Size		12 x 16.5	12 x 16.5	12 x 16.5
Ground Engaging Type		Bolt-on Edge	Bolt-on Edge	Bolt-on Edge
Bucket Assembly No.		279-5441	285-6090	268-4083
Rated bucket capacity	m ³	0.37	0.41	0.44
	yd ³	0.48	0.54	0.58
Struck capacity	m ³	0.27	0.30	0.32
	yd ³	0.35	0.39	0.42
Width	mm	1740	1893	2045
	in	68.5	74.5	80.5
Dump clearance at maximum lift/dump	mm	2356	2355	2354
	in	92.7	92.7	92.7
Reach at maximum lift/dump	mm	762	763	764
	in	30.0	30.0	30.1
Floor angle at maximum lift/dump	degrees	-50.3	-50.3	-50.3
Floor angle at maximum lift/rack back	degrees	84.7	84.6	84.6
Clearance at maximum lift/level bucket	mm	2964	2963	2963
	in	116.7	116.7	116.6
Hinge pin height at maximum lift	mm	3173	3172	3171
	in	124.9	124.9	124.9
Maximum overall height	mm	4042	4041	4040
	in	159.1	159.1	159.1
Reach at level lift arm/bucket	mm	1305	1306	1306
	in	51.4	51.4	51.4
Maximum floor angle at minimum lift	degrees	26.6	26.6	26.6
Dig depth with level bucket	mm	-9	-9	-10
	in	-0.3	-0.4	-0.4
Overall length with bucket on ground	mm	3740	3740	3740
	in	147.2	147.2	147.2
Front clearance circle radius (with bucket)	mm	2212	2244	2277
	in	87.1	88.3	89.6
Tipping load	kg	2467.9	2451.6	2436.5
	lb	5441	5405	5371
Breakout force — lift	kg	2450.5	2436.5	2423.0
	lb	5402	5372	5342
Breakout force — tilt	kg	3155.8	3146.0	3141.2
	lb	6957	6936	6925
Operating weight	kg	3644.7	3660.8	3678.1
	lb	8035	8071	8109

Work Tool	Pallet Fork		
	910 mm (36")	1070 mm (42")	1220 mm (48")
Tine Length	910 mm (36")	1070 mm (42")	1220 mm (48")
Tire Size	12 x 16.5	12 x 16.5	12 x 16.5
Carriage Assembly No.	353-1694	353-1696	353-1697
Carriage overall width without step	mm	1160	1160
	in	45.7	45.7
Carriage step additional width	mm	106	106
	in	4.2	4.2
Carriage height above blade top	mm	926	926
	in	36.5	36.5
Blade surface height at maximum height	mm	3158	3158
	in	124.3	124.3
Shank front face reach at maximum height	mm	672	673
	in	26.5	26.5
Blade surface height at level lift arms	mm	1495	1495
	in	58.9	58.8
Shank front face reach at level lift arms	mm	736	736
	in	29.0	29.0
Blade surface height at minimum lift	mm	91	91
	in	3.6	3.6
Shank front face reach at minimum lift	mm	421	421
	in	16.6	16.6
Overall length at minimum lift, level tine	mm	4078	4238
	in	160.6	166.9
Tipping load	kg	1941.0	1841.8
	lb	4279	4060
Operating weight	kg	3588.8	3599.1
	lb	7912	7935

Bucket Type		General Purpose: Bolt-on Edge		
Bucket Width		1830 mm (72")	1981 mm (78")	2134 mm (84")
Tire Size		12 x 16.5	12 x 16.5	12 x 16.5
Ground Engaging Type		Bolt-on Edge	Bolt-on Edge	Bolt-on Edge
Bucket Assembly No.		279-5373	279-5377	296-8192
Rated bucket capacity	m ³	0.44	0.48	0.63
	yd ³	0.58	0.63	0.82
Struck capacity	m ³	0.31	0.32	0.59
	yd ³	0.41	0.42	0.77
Width	mm	1893	2045	2198
	in	74.5	80.5	86.5
Dump clearance at maximum lift/dump	mm	2360	2360	2284
	in	92.9	92.9	89.9
Reach at maximum lift/dump	mm	808	809	868
	in	31.8	31.9	34.2
Floor angle at maximum lift/dump	degrees	-51.1	-51.1	-51.1
Floor angle at maximum lift/rack back	degrees	83.1	83.9	83.9
Clearance at maximum lift/level bucket	mm	3027	3026	3023
	in	119.2	119.1	119.0
Hinge pin height at maximum lift	mm	3227	3226	3225
	in	127.1	127.0	127.0
Maximum overall height	mm	4139	4142	4233
	in	162.9	163.1	166.7
Reach at level lift arm/bucket	mm	1365	1365	1459
	in	53.7	53.7	57.5
Maximum floor angle at minimum lift	degrees	28.4	28.4	28.3
Dig depth with level bucket	mm	-5	-6	-8
	in	-0.2	-0.2	-0.3
Overall length with bucket on ground	mm	4042	4042	4134
	in	159.1	159.1	162.8
Front clearance circle radius (with bucket)	mm	2355	2387	2495
	in	92.7	94.0	98.2
Tipping load	kg	2910.9	2895.5	2799.3
	lb	6417	6383	6171
Breakout force — lift	kg	2631.7	2620.5	2517.3
	lb	5802	5777	5550
Breakout force — tilt	kg	2896.0	2887.8	2650.3
	lb	6384	6366	5843
Operating weight	kg	4056.1	4070.4	4107.3
	lb	8942	8974	9055

Bucket Type		Multi-Purpose: Bolt-on Edge		Dirt: Bolt-on Edge	
Bucket Width		1830 mm (72")	1981 mm (78")	1830 mm (72")	1981 mm (78")
Tire Size		12 x 16.5	12 x 16.5	12 x 16.5	12 x 16.5
Ground Engaging Type		Bolt-on Edge	Bolt-on Edge	Bolt-on Edge	Bolt-on Edge
Bucket Assembly No.		279-5399	279-5402	285-6090	268-4083
Rated bucket capacity	m ³	0.37	0.40	0.41	0.44
	yd ³	0.48	0.52	0.54	0.58
Struck capacity	m ³	0.26	0.28	0.30	0.32
	yd ³	0.34	0.37	0.39	0.42
Width	mm	1902	2045	1893	2045
	in	74.9	80.5	74.5	80.5
Dump clearance at maximum lift/dump	mm	2346	2346	2404	2403
	in	92.4	92.3	94.6	94.6
Reach at maximum lift/dump	mm	816	817	776	777
	in	32.1	32.2	30.6	30.6
Floor angle at maximum lift/dump	degrees	-51.2	-51.3	-51.0	-51.1
Floor angle at maximum lift/rack back	degrees	83.8	83.8	83.9	83.9
Clearance at maximum lift/level bucket	mm	3015	3014	3030	3029
	in	118.7	118.7	119.3	119.2
Hinge pin height at maximum lift	mm	3223	3222	3228	3227
	in	126.9	126.8	127.1	127.1
Maximum overall height	mm	4144	4143	4091	4090
	in	163.2	163.1	161.1	161.0
Reach at level lift arm/bucket	mm	1375	1375	1356	1312
	in	54.1	54.1	53.4	51.6
Maximum floor angle at minimum lift	degrees	28.2	28.2	28.4	28.4
Dig depth with level bucket	mm	-15	-16	-2	-3
	in	-0.6	-0.6	-0.1	-0.1
Overall length with bucket on ground	mm	4048	4047	3989	3989
	in	159.4	159.3	157.0	157.0
Front clearance circle radius (with bucket)	mm	2362	2394	2311	2344
	in	93.0	94.2	91.0	92.3
Tipping load	kg	2742.2	2735.3	3008.3	2993.3
	lb	6045	6030	6632	6599
Breakout force — lift	kg	2515.7	2498.7	2691.8	2678.1
	lb	5546	5509	5934	5904
Breakout force — tilt	kg	2801.6	2786.7	3028.1	3018.2
	lb	6176	6144	6676	6654
Operating weight	kg	4196.8	4216.7	4034.0	4051.3
	lb	9252	9296	8893	8931

Work Tool		Pallet Fork		
		910 mm (36")	1070 mm (42")	1220 mm (48")
Tine Length		910 mm (36")	1070 mm (42")	1220 mm (48")
Tire Size		12 x 16.5	12 x 16.5	12 x 16.5
Carriage Assembly No.		353-1694	353-1696	353-1697
Carriage overall width without step	mm	1160	1160	1160
	in	45.7	45.7	45.7
Carriage step additional width	mm	106	106	106
	in	4.2	4.2	4.2
Carriage height above blade top	mm	926	926	926
	in	36.5	36.5	36.5
Blade surface height at maximum height	mm	3128	3140	3140
	in	123.1	123.6	123.6
Shank front face reach at maximum height	mm	709	700	701
	in	27.9	27.5	27.6
Blade surface height at level lift arms	mm	1454	1466	1466
	in	57.2	57.7	57.7
Shank front face reach at level lift arms	mm	751	741	742
	in	29.6	29.2	29.2
Blade surface height at minimum lift	mm	105	107	108
	in	4.1	4.2	4.2
Shank front face reach at minimum lift	mm	443	443	444
	in	17.4	17.4	17.5
Overall length at minimum lift, level tine	mm	4331	4491	4641
	in	170.5	176.8	182.7
Tipping load	kg	2369.1	2250.3	2147.7
	lb	5223	4961	4735
Operating weight	kg	3962.0	3972.3	3981.9
	lb	8735	8757	8778

Bucket Type		General Purpose: Bolt-on Edge		
Bucket Width		1830 mm (72")	1981 mm (78")	2134 mm (84")
Tire Size		14 x 17.5	14 x 17.5	14 x 17.5
Ground Engaging Type		Bolt-on Edge	Bolt-on Edge	Bolt-on Edge
Bucket Assembly No.		279-5373	279-5377	296-8192
Rated bucket capacity	m ³	0.44	0.48	0.63
	yd ³	0.58	0.63	0.82
Struck capacity	m ³	0.31	0.32	0.59
	yd ³	0.41	0.42	0.77
Width	mm	1893	2045	2198
	in	74.5	80.5	86.5
Dump clearance at maximum lift/dump	mm	2397	2397	2322
	in	94.4	94.4	91.4
Reach at maximum lift/dump	mm	774	774	833
	in	30.5	30.5	32.8
Floor angle at maximum lift/dump	degrees	-51.2	-51.2	-51.2
Floor angle at maximum lift/rack back	degrees	83.8	83.8	83.8
Clearance at maximum lift/level bucket	mm	3063	3063	3059
	in	120.6	120.6	120.5
Hinge pin height at maximum lift	mm	3265	3264	3263
	in	128.5	128.5	128.5
Maximum overall height	mm	4180	4179	4271
	in	164.6	164.5	168.1
Reach at level lift arm/bucket	mm	1328	1329	1423
	in	52.3	52.3	56.0
Maximum floor angle at minimum lift	degrees	27.6	27.5	27.5
Dig depth with level bucket	mm	-2	-2	-5
	in	-0.1	-0.1	-0.2
Overall length with bucket on ground	mm	4025	4025	4118
	in	158.5	158.5	162.1
Front clearance circle radius (with bucket)	mm	2345	2375	2484
	in	92.3	93.5	97.8
Tipping load	kg	3118.7	3103.1	3003.0
	lb	6876	6841	6621
Breakout force — lift	kg	2646.2	2635.0	2531.1
	lb	5834	5809	5580
Breakout force — tilt	kg	2949.5	2945.4	2622.6
	lb	6502	6493	5782
Operating weight	kg	4242.8	4257.1	4294.0
	lb	9354	9385	9467

Bucket Type		Multi-Purpose: Bolt-on Edge		Dirt: Bolt-on Edge	
Bucket Width		1830 mm (72")	1981 mm (78")	1830 mm (72")	1981 mm (78")
Tire Size		14 x 17.5	14 x 17.5	14 x 17.5	14 x 17.5
Ground Engaging Type		Bolt-on Edge	Bolt-on Edge	Bolt-on Edge	Bolt-on Edge
Bucket Assembly No.		279-5399	279-5402	285-6090	268-4083
Rated bucket capacity	m ³	0.37	0.40	0.41	0.44
	yd ³	0.48	0.52	0.54	0.58
Struck capacity	m ³	0.26	0.28	0.30	0.32
	yd ³	0.34	0.37	0.39	0.42
Width	mm	1902	2045	1893	2045
	in	74.9	80.5	74.5	80.5
Dump clearance at maximum lift/dump	mm	2385	2384	2441	2440
	in	93.9	93.9	96.1	96.1
Reach at maximum lift/dump	mm	780	781	742	742
	in	30.7	30.8	29.2	29.2
Floor angle at maximum lift/dump	degrees	-51.3	-51.3	-51.1	-51.2
Floor angle at maximum lift/rack back	degrees	83.7	83.7	83.8	83.8
Clearance at maximum lift/level bucket	mm	3053	3052	3066	3065
	in	120.2	120.2	120.7	120.7
Hinge pin height at maximum lift	mm	3261	3260	3265	3265
	in	128.4	128.4	128.6	128.5
Maximum overall height	mm	4182	4181	4128	4128
	in	164.7	164.6	162.5	162.5
Reach at level lift arm/bucket	mm	1338	1338	1275	1275
	in	52.7	52.7	50.2	50.2
Maximum floor angle at minimum lift	degrees	27.4	27.4	27.6	27.6
Dig depth with level bucket	mm	-10	-11	1	0
	in	-0.4	-0.4	0.0	0.0
Overall length with bucket on ground	mm	4031	4031	3972	3972
	in	158.7	158.7	156.4	156.4
Front clearance circle radius (with bucket)	mm	2350	2382	2299	2332
	in	92.5	93.8	90.5	91.8
Tipping load	kg	2946.8	2941.4	3223.3	3208.3
	lb	6497	6485	7106	7073
Breakout force — lift	kg	2530.3	2513.3	2706.7	2693.0
	lb	5578	5541	5967	5937
Breakout force — tilt	kg	2887.2	2876.1	3157.8	3153.0
	lb	6365	6341	6962	6951
Operating weight	kg	4383.5	4403.4	4220.7	4238.0
	lb	9664	9708	9305	9343

Work Tool	Pallet Fork		
	910 mm (36")	1070 mm (42")	1220 mm (48")
Tine Length	910 mm (36")	1070 mm (42")	1220 mm (48")
Tire Size	14 x 17.5	14 x 17.5	14 x 17.5
Carriage Assembly No.	353-1694	353-1696	353-1697
Carriage overall width without step	mm	1160	1160
	in	45.7	45.7
Carriage step additional width	mm	106	106
	in	4.2	4.2
Carriage height above blade top	mm	926	926
	in	36.5	36.5
Blade surface height at maximum height	mm	3173	3174
	in	124.9	125.0
Shank front face reach at maximum height	mm	666	667
	in	26.2	26.3
Blade surface height at level lift arms	mm	1499	1500
	in	59.0	59.1
Shank front face reach at level lift arms	mm	705	705
	in	27.7	27.8
Blade surface height at minimum lift	mm	107	109
	in	4.2	4.3
Shank front face reach at minimum lift	mm	389	389
	in	15.3	15.3
Overall length at minimum lift, level tine	mm	4314	4474
	in	169.9	176.2
Tipping load	kg	2511.5	2384.9
	lb	5537	5258
Operating weight	kg	4148.7	4159.0
	lb	9146	9169

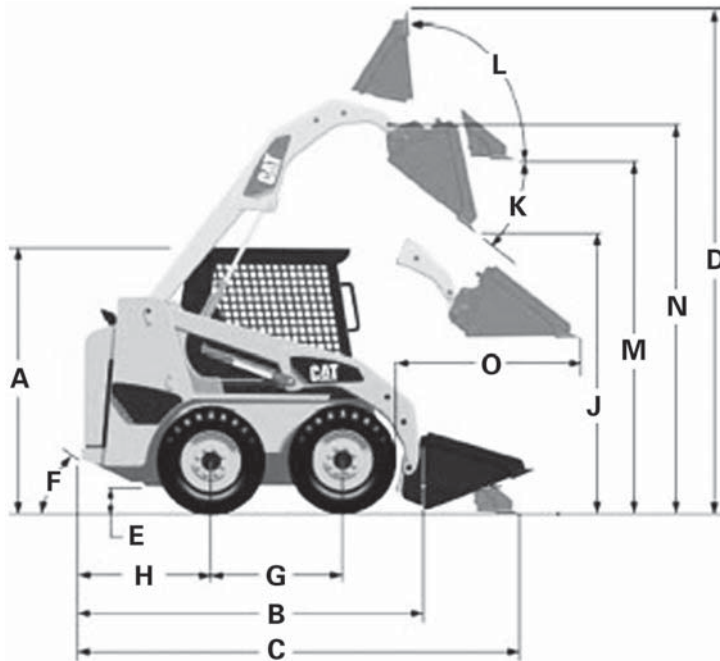

MODEL	216B3		226B3	
Rated operating capacity*	635 kg	1400 lb	680 kg	1500 lb
A Height to top of ROPS	1950 mm	6'5"	1950 mm	6'5"
B Length to coupler	2519 mm	8'3"	2519 mm	8'3"
C Length with bucket on ground	3233 mm	10'7"	3233 mm	10'7"
D Maximum overall height	3709 mm	12'2"	3709 mm	12'2"
E Ground clearance	195 mm	8"	195 mm	8"
F Departure angle		26°		26°
G Wheelbase	986 mm	3'3"	986 mm	3'3"
H Bumper overhang from axle	967 mm	3'2"	967 mm	3'2"
Bucket overall width	1524 mm	5'2"	1524 mm	5'2"
J Clearance at maximum lift/dump	2169 mm	7'1"	2169 mm	7'1"
K Floor angle at maximum lift/dump		40°		40°
L Floor angle at maximum lift/rack		96.7°		96.7°
M Clearance at maximum lift/level	2661 mm	8'9"	2661 mm	8'9"
N Hinge pin height at maximum lift	2854 mm	9'4"	2854 mm	9'4"
O Reach at level lift arm/bucket	1280 mm	4'2"	1280 mm	4'2"
Hinge pin height at carry position	239 mm	9.3"	239 mm	9.3"
Maximum floor angle at carry position		27.7°		27.7°

*SAE J818 MAY87, ISO 5998:1986.

NOTE: 216B3/226B3 machine dimensions shown with standard machine equipped with optional 10 x 16.5 10 PR tires and 1520 mm (60") dirt bucket.

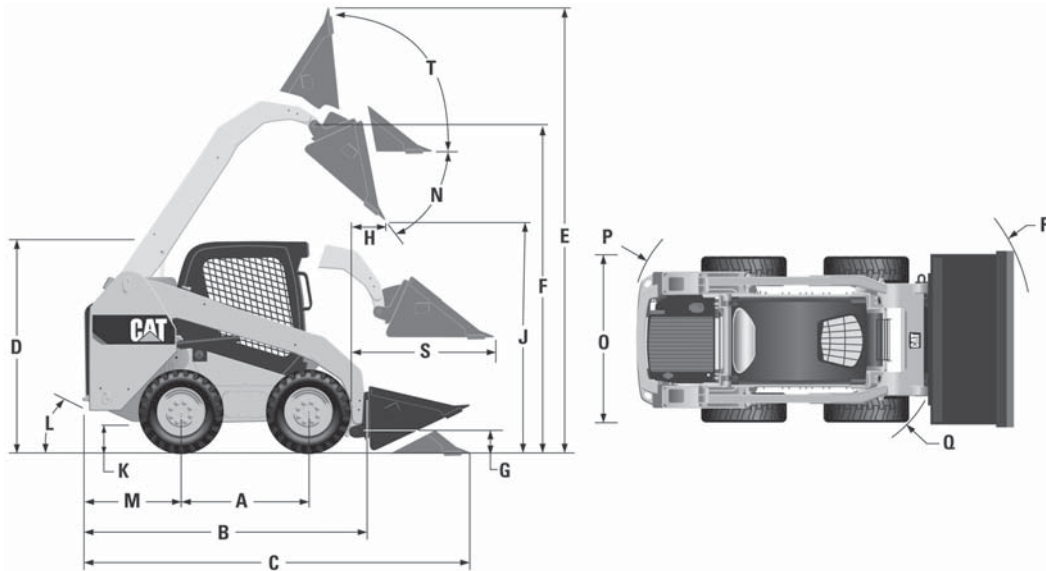

MODEL	226D		232D	
Operating weight	2588 kg	5705 lb	2818 kg	6213 lb
Rated operating capacity	697 kg	1536 lb	837 kg	1845 lb
Tipping load	1393 kg	3071 lb	1674 kg	3691 lb
Breakout force, tilt cylinder	1566 kg	3452 lb	1807 kg	3984 lb
A Wheelbase	1054 mm	41.5"	1054 mm	41.5"
B Length without bucket	2524 mm	99.4"	2523 mm	99.3"
C Length with bucket on ground	3234 mm	127.3"	3233 mm	127.3"
D Height to top of cab	2028 mm	79.8"	2029 mm	79.9"
E Maximum overall height	3652 mm	143.8"	3832 mm	150.9"
F Bucket pin height at maximum lift	2818 mm	110.9"	3001 mm	118.1"
G Bucket pin height at carry position	215 mm	8.5"	214 mm	8.4"
H Reach at maximum lift and dump	533 mm	21.0"	653 mm	25.7"
J Clearance at maximum lift and dump	2077 mm	81.8"	2254 mm	88.7"
K Ground clearance	175 mm	6.9"	170 mm	6.7"
L Departure angle		28°		28°
M Bumper overhang behind rear axle	894 mm	35.2"	894 mm	35.2"
N Maximum dump angle		47°		47°
O Vehicle width over tires	1497 mm	58.9"	1497 mm	58.9"
P Turning radius from center — machine rear	1513 mm	59.6"	1513 mm	59.6"
Q Turning radius from center — coupler	1104 mm	43.5"	1102 mm	43.4"
R Turning radius from center — bucket	1977 mm	77.8"	1976 mm	77.8"
S Maximum reach with arms parallel to ground	1288 mm	50.7"	1249 mm	49.2"
T Rack back angle at maximum height		27°		27°
Bucket pin reach at maximum lift	2818 mm	110.9"	3001 mm	118.1"

NOTE: Based on 75 kg (165 lb) operator, all fluids, one speed, OROPS, 1524 mm (60") dirt bucket, Cat 10 x 16.5 tires, standard flow hydraulics, mechanical suspension seat, no optional counterweights and manual quick coupler (unless otherwise noted).

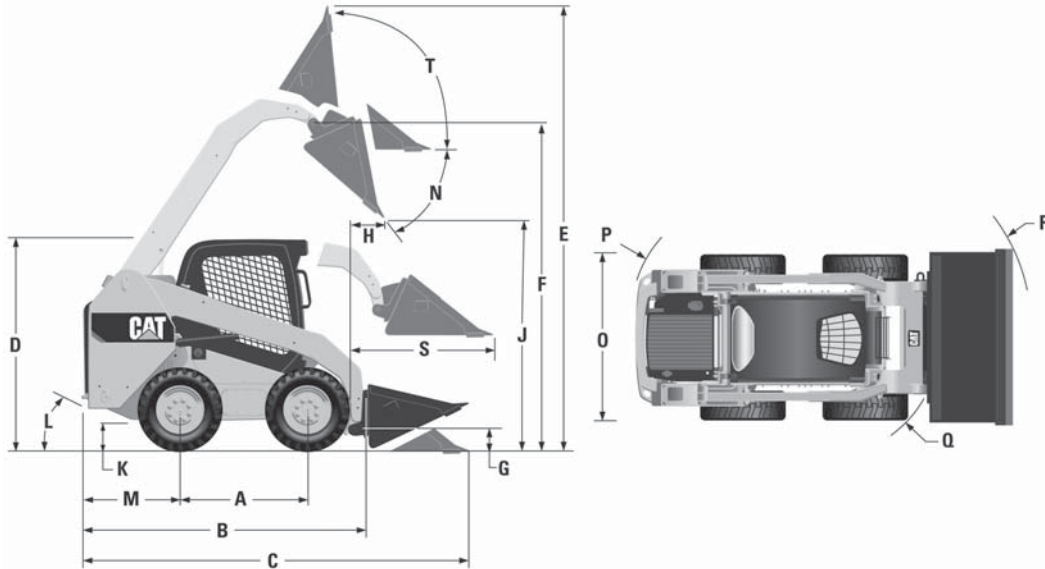

MODEL	236D		242D		246D	
	(10 x 16.5 tires)					
Operating weight	2975 kg	6559 lb	3166 kg	6980 lb	3368 kg	7424 lb
Rated operating capacity	818 kg	1800 lb	975 kg	2150 lb	975 kg	2150 lb
Tipping load	1633 kg	3600 lb	1950 kg	4300 lb	1950 kg	4300 lb
Breakout force, tilt cylinder	2302 kg	5074 lb	2283 kg	5034 lb	3336 kg	7355 lb
A Wheelbase	1105 mm	43.5"	1105 mm	43.5"	1249 mm	49.2"
B Length without bucket	2767 mm	108.9"	2767 mm	108.9"	2993 mm	117.8"
C Length with bucket on ground	3487 mm	137.3"	3487 mm	137.3"	3708 mm	146.0"
D Height to top of cab	2082 mm	82.0"	2111 mm	83.1"	2110 mm	83.1"
E Maximum overall height	3977 mm	156.6"	3917 mm	154.2"	4032 mm	158.7"
F Bucket pin height at maximum lift	3122 mm	122.9"	3076 mm	121.1"	3154 mm	124.2"
G Bucket pin height at carry position	190 mm	7.5"	200 mm	7.9"	200 mm	7.9"
H Reach at maximum lift and dump	408 mm	16.0"	552 mm	21.7"	600 mm	23.6"
J Clearance at maximum lift and dump	2359 mm	92.9"	2285 mm	90.0"	2465 mm	97.1"
K Ground clearance	195 mm	7.7"	222 mm	8.7"	226 mm	8.9"
L Departure angle		26°		27°		26°
M Bumper overhang behind rear axle	1021 mm	40.2"	1021 mm	40.2"	1083 mm	42.6"
N Maximum dump angle		48°		52°		39°
O Vehicle width over tires	1676 mm	66.0"	1675 mm	66.0"	1676 mm	66.0"
P Turning radius from center — machine rear	1639 mm	64.5"	1639 mm	64.5"	1806 mm	71.2"
Q Turning radius from center — coupler	1314 mm	51.8"	1314 mm	51.8"	1401 mm	55.2"
R Turning radius from center — bucket	2107 mm	83.0"	2107 mm	83.0"	2181 mm	85.9"
S Maximum reach with arms parallel to ground	1353 mm	53.3"	1249 mm	49.2"	1388 mm	54.6"
T Rack back angle at maximum height		91°		87°		96°
Bucket pin reach at maximum lift		—	182 mm	7.2"		—

NOTE: Based on 75 kg (165 lb) operator, all fluids, one speed, OROPS, 1676 mm (66") dirt bucket, Cat 12 x 16.5 tires, standard flow hydraulics, mechanical suspension seat, no optional counterweights and manual quick coupler (unless otherwise noted).

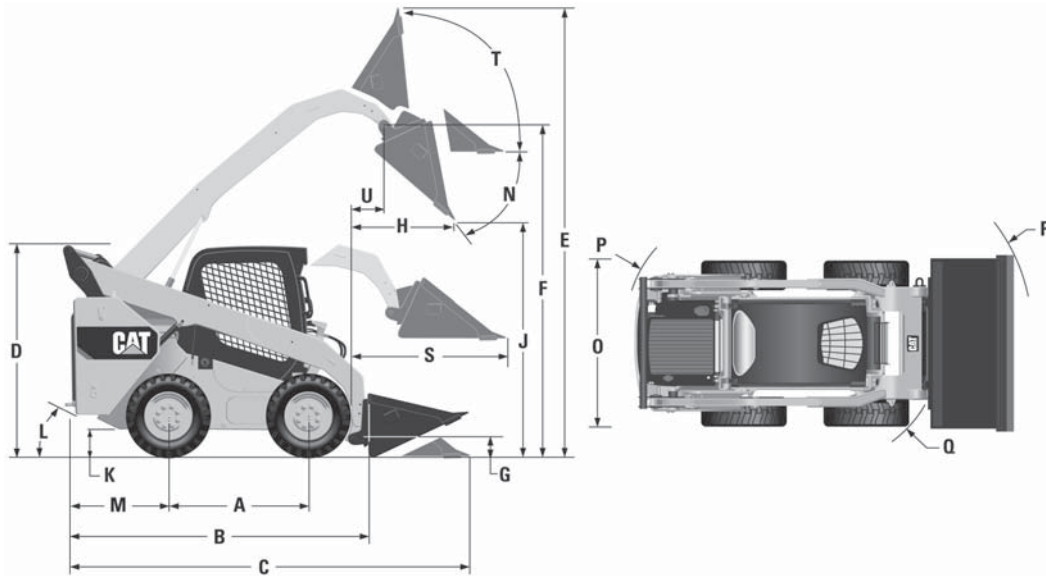

MODEL	262D		272D2		272D2 XHP	
Operating weight	3634 kg	8011 lb	3977 kg	8767 lb	4198 kg	9255 lb
Rated operating capacity	1225 kg	2700 lb	1544 kg	3405 lb	1649 kg	3635 lb
Tipping load	2449 kg	5400 lb	3089 kg	6810 lb	3297 kg	7269 lb
Breakout force, tilt cylinder	3336 kg	7355 lb	3147 kg	6937 lb	3326 kg	7332 lb
A Wheelbase	1249 mm	49.2"	1386 mm	54.6"	1386 mm	54.6"
B Length without bucket	2995 mm	117.9"	3242 mm	127.6"	3226 mm	127.0"
C Length with bucket on ground	3714 mm	146.2"	3954 mm	155.7"	3937 mm	155.0"
D Height to top of cab	2110 mm	83.1"	2094 mm	82.4"	2133 mm	84.0"
E Maximum overall height	4008 mm	157.8"	4067 mm	160.1"	4103 mm	161.5"
F Bucket pin height at maximum lift	3172 mm	124.9"	3229 mm	127.1"	3265 mm	128.6"
G Bucket pin height at carry position	200 mm	7.9"	198 mm	7.8"	235 mm	9.3"
H Reach at maximum lift and dump	786 mm	30.9"	769 mm	30.3"	736 mm	29.0"
J Clearance at maximum lift and dump	2380 mm	93.7"	2438 mm	96.0"	2474 mm	97.4"
K Ground clearance	226 mm	8.9"	226 mm	8.9"	263 mm	10.4"
L Departure angle		26°		27°		28°
M Bumper overhang behind rear axle	1083 mm	42.6"	1175 mm	46.2"	1175 mm	46.2"
N Maximum dump angle		51°		51°		51°
O Vehicle width over tires	1676 mm	66.0"	1829 mm	72.0"	1930 mm	76.0"
P Turning radius from center — machine rear	1805 mm	71.1"	1899 mm	74.7"	1899 mm	74.7"
Q Turning radius from center — coupler	1401 mm	55.2"	1482 mm	58.3"	1466 mm	57.7"
R Turning radius from center — bucket	2181 mm	85.9"	2280 mm	89.8"	2301 mm	90.6"
S Maximum reach with arms parallel to ground	1293 mm	50.9"	1282 mm	50.5"	1246 mm	49.1"
T Rack back angle at maximum height		84°		84°		84°
U Bucket pin reach at maximum lift	393 mm	15.5"	374 mm	14.7"	344 mm	13.5"

NOTE: 262D based on 75 kg (165 lb) operator, all fluids, one speed, OROPS, standard flow hydraulics, mechanical suspension seat, no optional counterweights and manual quick coupler (unless otherwise noted). 262D based on 1676 mm (66") dirt bucket and Cat 12 x 16.5 tires.

NOTE: 272D2 based on 75 kg (165 lb) operator, all fluids, one speed, C2 enclosed cab with heat, glass door, standard flow hydraulics, mechanical suspension seat, no optional counterweights and manual quick coupler (unless otherwise noted), 1829 mm (72") dirt bucket and Cat 12 x 16.5 tires.

NOTE: 272D2 XHP based on 75 kg (165 lb) operator, all fluids, one speed, C3 enclosed cab with A/C, glass door, standard flow hydraulics, mechanical suspension seat, no optional counterweights and manual quick coupler (unless otherwise noted), 1981 mm (78") dirt bucket and Cat 14 x 17.5 tires.

CAT WORK TOOL COMPATIBILITY

	216B3	226B3	226D	232D	236D	242D	246D	262D	272D2	272D2 XHP
General Purpose Buckets										
1524 mm (60")	C	C	C	C	C	C	C	C	C	C
1676 mm (66")	C	C	C	C	C	C	C	C	C	C
1829 mm (72")	C	C	C	C	C	C	C	C	C	C
1981 mm (78")	C	C	C	C	C	C	C	C	C	C
High Capacity Bucket (GP)										
2134 mm (84")	C	C	C	C	C	C	C	C	C	C
Dirt Buckets										
1372 mm (54")	C	C	C	C	C	C	C	C	C	C
1524 mm (60")	C	C	C	C	C	C	C	C	C	C
1676 mm (66")	C	C	C	C	C	C	C	C	C	C
1829 mm (72")	C	C	C	C	C	C	C	C	C	C
1981 mm (78")	C	C	C	C	C	C	C	C	C	C
Utility Buckets										
1524 mm (60")	C	C	C	C	C	C	C	C	C	C
1676 mm (66")	C	C	C	C	C	C	C	C	C	C
1829 mm (72")	C	C	C	C	C	C	C	C	C	C
Light Material Buckets										
1829 mm (72")	C	C	C	C	C	C	C	C	C	C
1981 mm (78")	C	C	C	C	C	C	C	C	C	C
2134 mm (84")	C	C	C	C	C	C	C	C	C	C
2438 mm (96")	C	C	C	C	C	C	C	C	C	C
Multi-Purpose Buckets										
1524 mm (60")	C	C	C	C	C	C	C	C	C	C
1676 mm (66")	C	C	C	C	C	C	C	C	C	C
1829 mm (72")	C	C	C	C	C	C	C	C	C	C
1981 mm (78")	C	C	C	C	C	C	C	C	C	C
2134 mm (84")	C	C	C	C	C	C	C	C	C	C
Industrial Grapple Buckets										
1524 mm (60")	C	C	C	C	C	C	C	C	C	C
1676 mm (66")	C	C	C	C	C	C	C	C	C	C
1829 mm (72")	C	C	C	C	C	C	C	C	C	C
1981 mm (78")	C	C	C	C	C	C	C	C	C	C
Industrial Grapple Forks										
1676 mm (66")	C	C	C	C	C	C	C	C	C	C
1829 mm (72")	C	C	C	C	C	C	C	C	C	C
Industrial Grapple Rakes										
1829 mm (72")	C	C	C	C	C	C	C	C	C	C
2134 mm (84")	C	C	C	C	C	C	C	C	C	C
Utility Grapple Buckets										
1676 mm (66")	C	C	C	C	C	C	C	C	C	C
1829 mm (72")	C	C	C	C	C	C	C	C	C	C

C – Compatible.

CAT WORK TOOL COMPATIBILITY

	216B3	226B3	226D	232D	236D	242D	246D	262D	272D2	272D2 XHP
Carriage	C	C	C	C	C	C	C	C	C	C
Pallet Forks										
910 mm (36") Tines	C	C	C	C	C	C	C	C	C	C
1070 mm (42") Tines	C	C	C	C	C	C	C	C	C	C
1220 mm (48") Tines	C	C	C	C	C	C	C	C	C	C
Utility Grapple Forks										
1676 mm (66")	C	C	C	C	C	C	C	C	C	C
1829 mm (72")	C	C	C	C	C	C	C	C	C	C
Utility Forks										
1676 mm (66")	C	C	C	C	C	C	C	C	C	C
1829 mm (72")	C	C	C	C	C	C	C	C	C	C
Angle Blades										
1829 mm (72")	C	C	C	C	C	C	C	C	C	C
2134 mm (84")	C	C	C	C	C	C	C	C	C	C
Dozer Blades										
2000 mm (79")	C	C	C	C	C	C	C	C	C	C
2337 mm (92")	C	C	C	C	C	C	C	C	C	C
A14B Auger	C	C	C	C	C	C	C	C	C	C
A19B Auger	C	C	C	C	C	C	C	C	C	C
A26B Auger	X	C	C	C	C	C	C	C	C	C
BH150 Backhoe	C	C	C	C	C	C	C	C	C	C
BH160 Backhoe	X	X	X	X	X	X	C	C	C	C
BR160 Brushcutter	C	C	C	C	X	X	X	X	X	X
BR166 Brushcutter	C	C	X	X	C	C	C	C	C	C
BR172 Brushcutter	C	C	X	X	C	C	C	C	C	C
BR272 Brushcutter	X	C	C	C	X	X	X	X	X	X
BR378 Brushcutter	X	X	X	X	X	X	C	C	C	C
BP115C Pickup Broom	C	C*	C*	C*	C*	C	C	C	C	C
BP118C Pickup Broom	X	X	X	X	C*	C	C	C	C	C
BA118C Angle Broom	C	C	C	C	C	C	C	C	C	C
BU115 Utility Broom	C	C	C	C	C	C	C	C	C	C
BU118 Utility Broom	X	X	X	X	C*	C*	C	C	C	C
PC104B Cold Planer	C	C	C	C	C	C	C	C	C	C
PC205B Cold Planer	X	C	C	C	C	C	C	C	C	C
PC305B Cold Planer	X	C	C	C	C	C	C	C	C	C
PC306B Cold Planer	X	C	C	C	C	C	C	C	C	C
PC306B XD Cold Planer	X	X	X	X	X	X	X	X	C*	C*
PC310B Cold Planer	X	X	X	X	X	X	C*	C	C	C
PC310B XD Cold Planer	X	X	X	X	X	X	X	X	X	X
PC408B Cold Planer	X	X	X	X	X	X	X	X	X	C
PC412B Cold Planer	X	X	X	X	X	X	X	X	X	X

C – Compatible.
 C* – Compatible but Lift Restrictions Apply.
 X – Not Compatible.

CAT WORK TOOL COMPATIBILITY

	216B3	226B3	226D	232D	236D	242D	246D	262D	272D2	272D2 XHP
H55E S Hammer	C,D	C,D	C,D	C,D	C,D	C,D	C,D	C,D	C,D	C,D
H65E S Hammer	C,D	C,D	C,D	C,D	C,D	C,D	C,D	C,D	C,D	C,D
LR15B Landscape Rake	C	C*	C*	C*	C*	C*	C	C	C	C
LR18B Landscape Rake	X	X	X	X	X	X	C	C	C	C
LT13B Landscape Tiller	C	C	C	C	C	C	C	C	C	C
LT18B Landscape Tiller	X	X	X	X	X	X	C	C	C	C
Material Handling Arm	C	C	C	C	C	C	C	C	C	C
HM315B Mulcher	X	X	X	X	X	X	C	C	C	C
HM415B Mulcher	X	X	X	X	X	X	X	X	X	C
PR172 Power Box Rake	C	C	C	C	C	C	C	C	C	C
PR184 Power Box Rake	C	C	C	C	C	C	C	C	C	C
PR190 Power Box Rake	C	C	C	C	C	C	C	C	C	C
S305 Shear	X	X	X	X	C,D	C,D	C,D	C,D	C,D	C,D
Sectional Snow Push 2440 mm (8 ft)	C	C	C	C	C	C	C	C	C	C
Sectional Snow Push 3050 mm (10 ft)	X	X	X	X	C	C	C	C	C	C
Sectional Snow Push 3660 mm (12 ft)	X	X	X	X	X	X	X	C	C	C
Sectional Snow Push 4270 mm (15 ft)	X	X	X	X	X	X	X	X	C	C
SR117 Snowblower	C	C	C	C	X	X	X	X	X	X
SR118 Snowblower	X	X	X	X	C	C	C	C	C	C
SR121 Snowblower	X	X	X	X	C	C	C	C	C	C
SR318 Snowblower	X	C	C	C	C	C	C	C	C	C
SR321 Snowblower	X	C	C	C	C	C	C	C	C	C
SG16B Stump Grinder	C	C	C	C	C	C	C	C	C	C
SG18B Stump Grinder	X	C	C	C	C	C	C	C	C	C
T6B Trencher	C	C	C	C	C	C	C	C	C	C
T9B Trencher	C	C	C	C	C	C	C	C	C	C
T15B Trencher	X	C*	C	C	C	C	C	C	C	C
CV16B Vibratory Compactor	C*	C*	C*	C*	C	C	C	C	C	C
CV18B Vibratory Compactor	X	X	X	X	X	X	C	C	C	C
SW345B Wheel Saw – 80 mm (3")	X	X	X	X	X	X	C^	C^	C	C
SW345B Wheel Saw – 130 mm (5")	X	X	X	X	X	X	C^	C^	C	C
SW360B Wheel Saw – 80 mm (3")	X	X	X	X	X	X	X	X	C^	C^
SW360B Wheel Saw – 100 mm (4")	X	X	X	X	X	X	X	C^	C^	C^
SW360B Wheel Saw – 130 mm (5")	X	X	X	X	X	X	X	C^	C^	C^
SW360B Wheel Saw – 150 mm (6")	X	X	X	X	X	X	X	C^	C^	C^
SW360B Wheel Saw – 200 mm (8")	X	X	X	X	X	X	X	C^	C^	C^
SW460B Wheel Saw – 80 mm (3")	X	X	X	X	X	X	X	X	X	C^
SW460B Wheel Saw – 150 mm (6")	X	X	X	X	X	X	X	X	X	C^
SW460B Wheel Saw – 200 mm (8")	X	X	X	X	X	X	X	X	X	C^
SW380B Wheel Saw – 250 mm (10")	X	X	X	X	X	X	X	X	C^	C^
SW480B Wheel Saw – 250 mm (10")	X	X	X	X	X	X	X	X	X	C^

C – Compatible.

C* – Compatible but Lift Restrictions Apply.

C^ – Compatible but Lift Restrictions Apply and Maximum Machine Counterweights Required.

D – European Union Restrictions Apply; Refer to Operation Maintenance Manual, "Safety Section: Worktools: Demolition."

X – Not Compatible.

MODEL	257D		277D		287D	
Flywheel Power:						
Gross (SAE J1995)	55.4 kW	74.3 hp	55.4 kW	74.3 hp	55.4 kW	74.3 hp
Net (SAE 1349)*	54.6 kW	73.2 hp	54.6 kW	73.2 hp	54.6 kW	73.2 hp
Net (SAE 1349)†	54.2 kW	72.7 hp	54.0 kW	72.4 hp	54.0 kW	72.4 hp
Net (SAE 1349)#	53.8 kW	72.1 hp	53.6 kW	71.8 hp	53.6 kW	71.8 hp
Engine Model	C3.3B DIT		C3.3B DIT		C3.3B DIT	
Rated Engine RPM	2400		2400		2400	
Bore	94 mm	3.7"	94 mm	3.7"	94 mm	3.7"
Stroke	120 mm	4.7"	120 mm	4.7"	120 mm	4.7"
Displacement	3.3 L	203 in³	3.3 L	203 in³	3.3 L	203 in³
No. Cylinders	4		4		4	
One Speed Forward	0-10.1 km/h	0-6.3 mph	0-9.6 km/h	0-6.0 mph	0-9.6 km/h	0-6.0 mph
Two Speed Forward	0-16.0 km/h	0-9.9 mph	0-15.1 km/h	0-9.4 mph	0-15.1 km/h	0-9.4 mph
One Speed Reverse	0-10.1 km/h	0-6.3 mph	0-9.6 km/h	0-6.0 mph	0-9.6 km/h	0-6.0 mph
Two Speed Reverse	0-16.0 km/h	0-9.9 mph	0-15.1 km/h	0-9.4 mph	0-15.1 km/h	0-9.4 mph
Hydraulic CycleTime, Empty Bucket:	Seconds		Seconds		Seconds	
Raise	4.4		3.1		4.6	
Dump	2.4		2.5		2.3	
Lower (Empty, Float Down)	3.6		4.0		4.0	
Total	10.4		9.6		10.9	
Tread Width	381 mm	15"	457 mm	18"	457 mm	18"
Width Over Tracks	1676 mm	76"	1981 mm	78"	1981 mm	78"
Ground Clearance	242 mm	9.5"	226 mm	8.9"	226 mm	8.9"
Fuel Tank Capacity	105 L	27.7 U.S. gal	94 L	24.8 U.S. gal	94 L	24.8 U.S. gal
Hydraulic Tank Capacity	39 L	10.3 U.S. gal	39 L	10.3 U.S. gal	39 L	10.3 U.S. gal
Hydraulic System Capacity (includes tank)	50 L	13.2 U.S. gal	52 L	13.7 U.S. gal	52 L	13.7 U.S. gal
Hydraulic Pump Capacity, Standard	76 L/min	20 gpm	86 L/min	23 gpm	86 L/min	23 gpm
Loader Hydraulic Pressure, Standard	23 000 kPa	3335 psi	23 000 kPa	3335 psi	23 000 kPa	3335 psi
Hydraulic Pump Capacity, XPS	112 L/min	30 gpm	121 L/min	32 gpm	121 L/min	32 gpm
Loader Hydraulic Pressure, XPS	23 000 kPa	3335 psi	28 000 kPa	4061 psi	28 000 kPa	4061 psi

*Meets Tier 4 Final, Stage IIIB, Japan 2011 (Tier 4 Interim) emission standards.

†Meets Tier 4 Interim, Stage IIIA, Japan 2006 (Tier 3) equivalent emission standards OR Tier 2, Stage II, Japan 2001 (Tier 2) equivalent emission standards.

#Meets Tier 4 Interim, Stage IIIA, Japan 2006 (Tier 3) equivalent emission standards OR Tier 2, Stage II, Japan 2001 (Tier 2) equivalent emission standards.

MODEL	297D2		297D2 XHP	
Flywheel Power:				
Gross (SAE J1995)	73.2 kW	98.2 hp	82.0 kW	110.0 hp
Net (SAE 1349)*	70.6 kW	94.7 hp	79.0 kW	105.9 hp
Engine Model	C3.8 DIT		C3.8 DITA	
Rated Engine RPM	2400		2400	
Bore	100 mm	3.9"	100 mm	3.9"
Stroke	120 mm	4.7"	120 mm	4.7"
Displacement	3.8 L	231.9 in³	3.8 L	231.9 in³
No. Cylinders	4		4	
One Speed Forward	9.6 km/h	5.9 mph	9.6 km/h	5.9 mph
Two Speed Forward	15.1 km/h	9.4 mph	15.1 km/h	9.4 mph
One Speed Reverse	9.6 km/h	5.9 mph	9.6 km/h	5.9 mph
Two Speed Reverse	15.1 km/h	9.4 mph	15.1 km/h	9.4 mph
Hydraulic Cycle Time, Empty Bucket:	Seconds		Seconds	
Raise	5.2		4.4	
Dump	2.3		2.0	
Lower (Empty, Float Down)	4.6		4.7	
Total	12.1		11.1	
Tread Width	400 mm	15.7"	400 mm	15.7"
Width Over Tracks	1984 mm	78.1"	1984 mm	78.1"
Ground Clearance	223 mm	8.8"	223 mm	8.8"
Fuel Tank Capacity	122 L	32.2 U.S. gal	122 L	32.2 U.S. gal
Hydraulic Tank Capacity	39 L	10.3 U.S. gal	39 L	10.3 U.S. gal
Hydraulic System Capacity (includes tank)	55 L	14.5 U.S. gal	55 L	14.5 U.S. gal
Hydraulic Pump Capacity, Standard	86 L/min	23 gpm	86 L/min	23 gpm
Loader Hydraulic Pressure, Standard	23 000 kPa	3336 psi	23 000 kPa	3336 psi
Hydraulic Pump Capacity, XPS	121 L/min	32 gpm	—	—
Loader Hydraulic Pressure, XPS	28 000 kPa	4061 psi	—	—
Hydraulic Pump Capacity, XHP	—	—	150 L/min	40 gpm
Loader Hydraulic Pressure, XHP	—	—	28 000 kPa	4061 psi

*Meets Tier 4 Final, Stage IIIB, Japan 2011 (Tier 4 Interim) emission standards.

Bucket Type		General Purpose: Bolt-on Edge		Multi-Purpose: Bolt-on Edge	
Bucket Width		1680 mm (66")	1830 mm (72")	1680 mm (66")	1830 mm (72")
Ground Engaging Type		Bolt-on Edge	Bolt-on Edge	Bolt-on Edge	Bolt-on Edge
Bucket Assembly No.		279-5369	279-5373	279-5391	279-5399
Rated bucket capacity	m ³	0.40	0.44	0.34	0.37
	yd ³	0.52	0.58	0.44	0.48
Struck capacity	m ³	0.29	0.31	0.25	0.26
	yd ³	0.38	0.41	0.33	0.34
Width	mm	1740	1893	1749	1902
	in	68.5	74.5	68.9	74.9
Dump clearance at maximum lift/dump	mm	2190	2188	2174	2172
	in	86.2	86.2	85.6	85.5
Reach at maximum lift/dump	mm	711	712	722	723
	in	28.0	28.0	28.4	28.5
Floor angle at maximum lift/dump	degrees	-53.4	-53.4	-53.7	-53.7
Floor angle at maximum lift/rack back	degrees	85.9	85.8	85.6	85.5
Clearance at maximum lift/level bucket	mm	2854	2853	2844	2843
	in	112.3	112.3	112.0	111.9
Hinge pin height at maximum lift	mm	3064	3063	3057	3056
	in	120.6	120.6	120.4	120.3
Maximum overall height	mm	3979	3978	3978	3977
	in	156.7	156.6	156.6	156.6
Reach at level lift arm/bucket	mm	1441	1442	1454	1455
	in	56.7	56.8	57.2	57.3
Maximum floor angle at minimum lift	degrees	23.8	23.8	23.8	23.8
Dig depth with level bucket	mm	-20	-21	-29	-30
	in	-0.8	-0.8	-1.2	-1.2
Overall length with bucket on ground	mm	3555	3555	3561	3560
	in	140.0	140.0	140.2	140.2
Front clearance circle radius (with bucket)	mm	2257	2288	2260	2291
	in	88.9	90.1	89.0	90.2
Tipping load	kg	2365.9	2349.0	2211.5	2189.6
	lb	5216	5179	4876	4827
Breakout force — lift	kg	1994.8	1981.6	1885.8	1867.4
	lb	4398	4369	4157	4117
Breakout force — tilt	kg	2033.4	2024.3	1972.5	1962.9
	lb	4483	4463	4348	4327
Operating weight	kg	3693.0	3708.5	3826.4	3849.2
	lb	8142	8176	8436	8486

Bucket Type		Dirt: Bolt-on Edge	
Bucket Width		1680 mm (66")	1830 mm (72")
Ground Engaging Type		Bolt-on Edge	Bolt-on Edge
Bucket Assembly No.		279-5441	285-6090
Rated bucket capacity	m ³	0.37	0.41
	yd ³	0.48	0.54
Struck capacity	m ³	0.27	0.30
	yd ³	0.35	0.39
Width	mm	1740	1893
	in	68.5	74.5
Dump clearance at maximum lift/dump	mm	2235	2234
	in	88.0	88.0
Reach at maximum lift/dump	mm	679	681
	in	26.7	26.8
Floor angle at maximum lift/dump	degrees	-53.3	-53.4
Floor angle at maximum lift/rack back	degrees	85.9	85.9
Clearance at maximum lift/level bucket	mm	2857	2856
	in	112.5	112.5
Hinge pin height at maximum lift	mm	3065	3064
	in	120.7	120.6
Maximum overall height	mm	3928	3927
	in	154.7	154.6
Reach at level lift arm/bucket	mm	1387	1388
	in	54.6	54.6
Maximum floor angle at minimum lift	degrees	23.8	23.8
Dig depth with level bucket	mm	-17	-17
	in	-0.7	-0.7
Overall length with bucket on ground	mm	3502	3502
	in	137.9	137.9
Front clearance circle radius (with bucket)	mm	2211	2242
	in	87.0	88.3
Tipping load	kg	2449.3	2433.4
	lb	5400	5365
Breakout force — lift	kg	2048.5	2034.6
	lb	4516	4485
Breakout force — tilt	kg	2182.4	2172.7
	lb	4811	4790
Operating weight	kg	3670.3	3686.4
	lb	8092	8127

Work Tool	Pallet Fork			
		910 mm (36")	1070 mm (42")	1220 mm (48")
Tine Length		910 mm (36")	1070 mm (42")	1220 mm (48")
Carriage Assembly No.		353-1694	353-1696	353-1697
Carriage overall width without step	mm	1160	1160	1160
	in	45.7	45.7	45.7
Carriage step additional width	mm	106	106	106
	in	4.2	4.2	4.2
Carriage height above blade top	mm	926	926	926
	in	36.5	36.5	36.5
Blade surface height at maximum height	mm	2959	2958	2957
	in	116.5	116.5	116.4
Shank front face reach at maximum height	mm	622	624	626
	in	24.5	24.6	24.7
Blade surface height at level lift arms	mm	1405	1405	1403
	in	55.3	55.3	55.2
Shank front face reach at level lift arms	mm	818	819	820
	in	32.2	32.2	32.3
Blade surface height at minimum lift	mm	81	81	80
	in	3.2	3.2	3.1
Shank front face reach at minimum lift	mm	483	483	484
	in	19.0	19.0	19.1
Overall length at minimum lift, level tine	mm	3855	4015	4165
	in	151.8	158.1	164.0
Tipping load	kg	1950.7	1846.9	1757.5
	lb	4300	4072	3875
Operating weight	kg	3614.4	3624.7	3634.3
	lb	7968	7991	8012

Bucket Type		General Purpose: Bolt-on Edge	
		1981 mm (78")	2134 mm (84")
Bucket Width		1981 mm (78")	2134 mm (84")
Tire Size		12 x 16.5	12 x 16.5
Ground Engaging Type		Bolt-on Edge	Bolt-on Edge
Bucket Assembly No.		279-5377	296-8192
Rated bucket capacity	m ³	0.48	0.63
	yd ³	0.63	0.82
Struck capacity	m ³	0.32	0.59
	yd ³	0.42	0.77
Width	mm	2045	2198
	in	80.5	86.5
Dump clearance at maximum lift/dump	mm	2418	2355
	in	95.2	92.7
Reach at maximum lift/dump	mm	655	730
	in	25.8	28.7
Floor angle at maximum lift/dump	degrees	-38.9	-39.0
Floor angle at maximum lift/rack back	degrees	96.1	96.0
Clearance at maximum lift/level bucket	mm	2963	2960
	in	116.7	116.5
Hinge pin height at maximum lift	mm	3173	3171
	in	124.9	124.9
Maximum overall height	mm	4134	4224
	in	162.7	166.3
Reach at level lift arm/bucket	mm	1480	1575
	in	58.3	62.0
Maximum floor angle at minimum lift	degrees	24.2	24.2
Dig depth with level bucket	mm	-8	-12
	in	-0.3	-0.5
Overall length with bucket on ground	mm	3777	3870
	in	148.7	152.4
Front clearance circle radius (with bucket)	mm	2412	2525
	in	94.9	99.4
Tipping load	kg	2418.7	2325.6
	lb	5332	5127
Breakout force — lift	kg	2630.1	2515.2
	lb	5798	5545
Breakout force — tilt	kg	2826.4	2515.5
	lb	6231	5546
Operating weight	kg	4267.3	4304.2
	lb	9408	9489

Bucket Type	Multi-Purpose: Bolt-on Edge		Dirt: Bolt-on Edge	
Bucket Width	1981 mm (78")	2134 mm (84")	1981 mm (78")	
Tire Size	12 x 16.5	12 x 16.5	12 x 16.5	
Bucket Assembly No.	Bolt-on Edge	Bolt-on Edge	Bolt-on Edge	
Bucket Assembly No.	279-5402	296-8057	268-4083	
Rated bucket capacity	m ³	0.40	0.43	0.44
	yd ³	0.52	0.56	0.58
Struck capacity	m ³	0.28	0.30	0.32
	yd ³	0.37	0.39	0.42
Width	mm	2045	2207	2045
	in	80.5	86.9	80.5
Dump clearance at maximum lift/dump	mm	2402	2400	2454
	in	94.6	94.5	96.6
Reach at maximum lift/dump	mm	670	671	614
	in	26.4	26.4	24.2
Floor angle at maximum lift/dump	degrees	-39.2	-39.2	-38.8
Floor angle at maximum lift/rack back	degrees	95.8	95.7	96.1
Clearance at maximum lift/level bucket	mm	2954	2953	2967
	in	116.3	116.3	116.8
Hinge pin height at maximum lift	mm	3167	3166	3174
	in	124.7	124.7	125.0
Maximum overall height	mm	4134	4133	4082
	in	162.8	162.7	160.7
Reach at level lift arm/bucket	mm	1494	1495	1426
	in	58.8	58.9	56.1
Maximum floor angle at minimum lift	degrees	24.2	24.2	24.2
Dig depth with level bucket	mm	-17	-18	-5
	in	-0.7	-0.7	-0.2
Overall length with bucket on ground	mm	3783	3782	3724
	in	148.9	148.9	146.6
Front clearance circle radius (with bucket)	mm	2414	2448	2366
	in	95.1	96.4	93.1
Tipping load	kg	2263.9	2241.3	2504.9
	lb	4991	4941	5522
Breakout force — lift	kg	2511.3	2491.6	2694.8
	lb	5537	5493	5941
Breakout force — tilt	kg	2757.1	2744.9	3026.1
	lb	6078	6051	6671
Operating weight	kg	4413.6	4437.6	4248.2
	lb	9730	9783	9366

Work Tool		Pallet Fork		
Tine Length		910 mm (36")	1070 mm (42")	1220 mm (48")
Tire Size		10 x 16.5	10 x 16.5	10 x 16.5
Carriage Assembly No.		353-1694	353-1696	353-1697
Carriage overall width without step	mm	1160	1160	1160
	in	45.7	45.7	45.7
Carriage step additional width	mm	106	106	106
	in	4.2	4.2	4.2
Carriage height above blade top	mm	926	926	926
	in	36.5	36.5	36.5
Blade surface height at maximum height	mm	3024	3024	3022
	in	119.1	119.0	119.0
Shank front face reach at maximum height	mm	457	459	461
	in	18.0	18.1	18.2
Blade surface height at level lift arms	mm	1449	1448	1446
	in	57.1	57.0	56.9
Shank front face reach at level lift arms	mm	902	903	905
	in	35.5	35.6	35.6
Blade surface height at minimum lift	mm	46	45	43
	in	1.8	1.8	1.7
Shank front face reach at minimum lift	mm	394	394	394
	in	15.5	15.5	15.5
Overall length at minimum lift, level tine	mm	4056	4216	4366
	in	159.7	166.0	171.9
Tipping load	kg	2098.2	1998.8	1912.4
	lb	4626	4407	4216
Operating weight	kg	4158.9	4169.2	4178.8
	lb	9169	9191	9213

Bucket Type		General Purpose: Bolt-on Edge	
		1981 mm (78")	2134 mm (84")
Bucket Width		1981 mm (78")	2134 mm (84")
Tire Size		12 x 16.5	12 x 16.5
Ground Engaging Type		Bolt-on Edge	Bolt-on Edge
Bucket Assembly No.		279-5377	296-8192
Rated bucket capacity	m ³	0.48	0.63
	yd ³	0.63	0.82
Struck capacity	m ³	0.32	0.59
	yd ³	0.42	0.77
Width	mm	2045	2198
	in	80.5	86.5
Dump clearance at maximum lift/dump	mm	2304	2227
	in	90.7	87.7
Reach at maximum lift/dump	mm	822	882
	in	32.3	34.7
Floor angle at maximum lift/dump	degrees	-51.3	-51.4
Floor angle at maximum lift/rack back	degrees	83.6	83.5
Clearance at maximum lift/level bucket	mm	2962	2958
	in	116.6	116.5
Hinge pin height at maximum lift	mm	3172	3169
	in	124.9	124.8
Maximum overall height	mm	4086	4175
	in	160.9	164.4
Reach at level lift arm/bucket	mm	1373	1468
	in	54.0	57.8
Maximum floor angle at minimum lift	degrees	26.3	26.3
Dig depth with level bucket	mm	-25	-29
	in	-1.0	-1.1
Overall length with bucket on ground	mm	3779	3872
	in	148.8	152.4
Front clearance circle radius (with bucket)	mm	2412	2526
	in	95.0	99.4
Tipping load	kg	3470.3	3356.3
	lb	7651	7399
Breakout force — lift	kg	2375.6	2275.8
	lb	5237	5017
Breakout force — tilt	kg	2922.6	2602.2
	lb	6443	5737
Operating weight	kg	4545.7	4582.6
	lb	10,021	10,103

Bucket Type		Multi-Purpose: Bolt-on Edge		Dirt: Bolt-on Edge
Bucket Width		1981 mm (78")	2134 mm (84")	1981 mm (78")
Tire Size		12 x 16.5	12 x 16.5	12 x 16.5
Bucket Assembly No.		Bolt-on Edge	Bolt-on Edge	Bolt-on Edge
Bucket Assembly No.		279-5402	296-8057	268-4083
Rated bucket capacity	m ³	0.40	0.43	0.44
	yd ³	0.52	0.56	0.58
Struck capacity	m ³	0.28	0.30	0.32
	yd ³	0.37	0.39	0.42
Width	mm	2045	2207	2045
	in	80.5	86.9	80.5
Dump clearance at maximum lift/dump	mm	2287	2286	2348
	in	90.1	90.0	92.4
Reach at maximum lift/dump	mm	833	835	789
	in	32.8	32.9	31.1
Floor angle at maximum lift/dump	degrees	-51.6	-51.6	-51.3
Floor angle at maximum lift/rack back	degrees	83.3	83.3	83.6
Clearance at maximum lift/level bucket	mm	2952	2950	2965
	in	116.2	116.2	116.7
Hinge pin height at maximum lift	mm	3165	3163	3173
	in	124.6	124.5	124.9
Maximum overall height	mm	4084	4083	4035
	in	160.8	160.7	158.8
Reach at level lift arm/bucket	mm	1387	1388	1319
	in	54.6	54.6	51.9
Maximum floor angle at minimum lift	degrees	26.3	26.3	26.3
Dig depth with level bucket	mm	-34	-35	-22
	in	-1.3	-1.4	-0.9
Overall length with bucket on ground	mm	3784	3784	3726
	in	149.0	149.0	146.7
Front clearance circle radius (with bucket)	mm	2415	2448	2367
	in	95.1	96.4	93.2
Tipping load	kg	3305.2	3282.7	3679.0
	lb	7287	7237	8111
Breakout force — lift	kg	2254.7	2234.7	2431.2
	lb	4971	4927	5360
Breakout force — tilt	kg	2853.3	2841.1	3128.6
	lb	6290	6263	6897
Operating weight	kg	4692.0	4716.0	4526.6
	lb	10,344	10,397	9979

Work Tool	Pallet Fork		
Tine Length	910 mm (36")	1070 mm (42")	1220 mm (48")
Tire Size	10 x 16.5	10 x 16.5	10 x 16.5
Carriage Assembly No.	353-1694	353-1696	353-1697
Carriage overall width without step	mm	1160	1160
	in	45.7	45.7
Carriage step additional width	mm	106	106
	in	4.2	4.2
Carriage height above blade top	mm	926	926
	in	36.5	36.5
Blade surface height at maximum height	mm	3011	3011
	in	118.6	118.5
Shank front face reach at maximum height	mm	811	812
	in	31.9	32.0
Blade surface height at level lift arms	mm	1484	1483
	in	58.4	58.4
Shank front face reach at level lift arms	mm	795	796
	in	31.3	31.3
Blade surface height at minimum lift	mm	38	37
	in	1.5	1.5
Shank front face reach at minimum lift	mm	401	401
	in	15.8	15.8
Overall length at minimum lift, level tine	mm	4070	4230
	in	160.2	166.5
Tipping load	kg	2854.2	2707.9
	lb	6292	5970
Operating weight	kg	4437.3	4447.6
	lb	9783	9805
			9826

Bucket Type		General Purpose: Bolt-on Edge	
		1981 mm (78")	2134 mm (84")
Bucket Width			
Tire Size		12 x 16.5	12 x 16.5
Ground Engaging Type		Bolt-on Edge	Bolt-on Edge
Bucket Assembly No.		279-5377	296-8192
Rated bucket capacity	m ³	0.48	0.63
	yd ³	0.63	0.82
Struck capacity	m ³	0.32	0.59
	yd ³	0.42	0.77
Width	mm	2045	2198
	in	80.5	86.5
Dump clearance at maximum lift/dump	mm	2366	2289
	in	93.1	90.1
Reach at maximum lift/dump	mm	816	876
	in	32.1	34.5
Floor angle at maximum lift/dump	degrees	-51.7	-51.8
Floor angle at maximum lift/rack back	degrees	83.3	83.3
Clearance at maximum lift/level bucket	mm	3008	3000
	in	118.4	118.1
Hinge pin height at maximum lift	mm	3238	3236
	in	127.5	127.4
Maximum overall height	mm	4150	4240
	in	163.4	166.9
Reach at level lift arm/bucket	mm	1359	1454
	in	53.5	57.2
Maximum floor angle at minimum lift	degrees	27.0	26.9
Dig depth with level bucket	mm	-54	-60
	in	-2.1	-2.4
Overall length with bucket on ground	mm	4015	4107
	in	158.1	161.7
Front clearance circle radius (with bucket)	mm	2408	2516
	in	94.8	99.1
Tipping load	kg	4021.1	3893.7
	lb	8865	8584
Breakout force — lift	kg	2630.0	2526.7
	lb	5798	5570
Breakout force — tilt	kg	2988.5	2661.5
	lb	6588	5868
Operating weight	kg	4908.9	4945.8
	lb	10,822	10,903

Bucket Type	Multi-Purpose: Bolt-on Edge		Dirt: Bolt-on Edge
	1981 mm (78")	2134 mm (84")	1981 mm (78")
Bucket Width	1981 mm (78")	2134 mm (84")	1981 mm (78")
Tire Size	12 x 16.5	12 x 16.5	12 x 16.5
Bucket Assembly No.	Bolt-on Edge	Bolt-on Edge	Bolt-on Edge
Bucket Assembly No.	279-5402	296-8057	268-4083
Rated bucket capacity	m ³	0.40	0.43
	yd ³	0.52	0.56
Struck capacity	m ³	0.28	0.30
	yd ³	0.37	0.39
Width	mm	2045	2207
	in	80.5	86.9
Dump clearance at maximum lift/dump	mm	2349	2347
	in	92.5	92.4
Reach at maximum lift/dump	mm	829	831
	in	32.6	32.7
Floor angle at maximum lift/dump	degrees	-52.0	-52.0
Floor angle at maximum lift/rack back	degrees	83.1	83.0
Clearance at maximum lift/level bucket	mm	2992	2990
	in	117.8	117.7
Hinge pin height at maximum lift	mm	3231	3230
	in	127.2	127.2
Maximum overall height	mm	4149	4147
	in	163.3	163.3
Reach at level lift arm/bucket	mm	1372	1373
	in	54.0	54.0
Maximum floor angle at minimum lift	degrees	26.8	26.7
Dig depth with level bucket	mm	-66	-68
	in	-2.6	-2.7
Overall length with bucket on ground	mm	4019	4019
	in	158.2	158.2
Front clearance circle radius (with bucket)	mm	2415	2448
	in	95.1	96.4
Tipping load	kg	3848.9	3826.4
	lb	8485	8436
Breakout force — lift	kg	2508.2	2488.0
	lb	5530	5485
Breakout force — tilt	kg	2919.2	2907.0
	lb	6436	6409
Operating weight	kg	5055.2	5079.2
	lb	11,145	11,198

Work Tool		Pallet Fork		
Tine Length		910 mm (36")	1070 mm (42")	1220 mm (48")
Tire Size		10 x 16.5	10 x 16.5	10 x 16.5
Carriage Assembly No.		353-1694	353-1696	353-1697
Carriage overall width without step	mm	1160	1160	1160
	in	45.7	45.7	45.7
Carriage step additional width	mm	106	106	106
	in	4.2	4.2	4.2
Carriage height above blade top	mm	926	926	926
	in	36.5	36.5	36.5
Blade surface height at maximum height	mm	3116	3113	3108
	in	122.7	122.5	122.4
Shank front face reach at maximum height	mm	706	708	710
	in	27.8	27.9	28.0
Blade surface height at level lift arms	mm	1432	1429	1425
	in	56.4	56.3	56.1
Shank front face reach at level lift arms	mm	734	734	736
	in	28.9	28.9	29.0
Blade surface height at minimum lift	mm	52	49	46
	in	2.1	1.9	1.8
Shank front face reach at minimum lift	mm	406	406	407
	in	16.0	16.0	16.0
Overall length at minimum lift, level tine	mm	4308	4467	4618
	in	169.6	175.9	181.8
Tipping load	kg	3315.5	3146.5	3001.5
	lb	7309	6937	6617
Operating weight	kg	4800.5	4810.8	4820.4
	lb	10,583	10,606	10,627

Bucket Type		General Purpose: Bolt-on Edge	
		1981 mm (78")	2134 mm (84")
Bucket Width		1981 mm (78")	2134 mm (84")
Tire Size		12 x 16.5	12 x 16.5
Ground Engaging Type		Bolt-on Edge	Bolt-on Edge
Bucket Assembly No.		279-5377	296-8192
Rated bucket capacity	m ³	0.48	0.63
	yd ³	0.63	0.82
Struck capacity	m ³	0.32	0.59
	yd ³	0.42	0.77
Width	mm	2045	2198
	in	80.5	86.5
Dump clearance at maximum lift/dump	mm	2366	2289
	in	93.1	90.1
Reach at maximum lift/dump	mm	816	876
	in	32.1	34.5
Floor angle at maximum lift/dump	degrees	-51.7	-51.8
Floor angle at maximum lift/rack back	degrees	83.3	83.3
Clearance at maximum lift/level bucket	mm	3008	3001
	in	118.4	118.1
Hinge pin height at maximum lift	mm	3238	3236
	in	127.5	127.4
Maximum overall height	mm	4150	4240
	in	163.4	166.9
Reach at level lift arm/bucket	mm	1358	1454
	in	53.5	57.2
Maximum floor angle at minimum lift	degrees	27.0	26.9
Dig depth with level bucket	mm	-53	-60
	in	-2.1	-2.4
Overall length with bucket on ground	mm	4015	4107
	in	158.1	161.7
Front clearance circle radius (with bucket)	mm	2408	2516
	in	94.8	99.1
Tipping load	kg	4103.7	3974.6
	lb	9047	8762
Breakout force — lift	kg	2624.9	2521.7
	lb	5787	5559
Breakout force — tilt	kg	2988.5	2661.5
	lb	6588	5868
Operating weight	kg	5011.2	5048.1
	lb	11,048	11,129

Bucket Type		Multi-Purpose: Bolt-on Edge		Dirt: Bolt-on Edge
Bucket Width		1981 mm (78")	2134 mm (84")	1981 mm (78")
Tire Size		12 x 16.5	12 x 16.5	12 x 16.5
Bucket Assembly No.		Bolt-on Edge	Bolt-on Edge	Bolt-on Edge
Bucket Assembly No.		279-5402	296-8057	268-4083
Rated bucket capacity	m ³	0.40	0.43	0.44
	yd ³	0.52	0.56	0.58
Struck capacity	m ³	0.28	0.30	0.32
	yd ³	0.37	0.39	0.42
Width	mm	2045	2207	2045
	in	80.5	86.9	80.5
Dump clearance at maximum lift/dump	mm	2349	2348	2410
	in	92.5	92.4	94.9
Reach at maximum lift/dump	mm	829	830	784
	in	32.6	32.7	30.9
Floor angle at maximum lift/dump	degrees	-51.9	-52.0	-51.6
Floor angle at maximum lift/rack back	degrees	83.1	83.0	83.4
Clearance at maximum lift/level bucket	mm	2992	2990	3013
	in	117.8	117.7	118.6
Hinge pin height at maximum lift	mm	3231	3230	3239
	in	127.2	127.2	127.5
Maximum overall height	mm	4149	4147	4099
	in	163.3	163.3	161.4
Reach at level lift arm/bucket	mm	1371	1372	1305
	in	54.0	54.0	51.4
Maximum floor angle at minimum lift	degrees	26.8	26.7	27.1
Dig depth with level bucket	mm	-66	-68	-49
	in	-2.6	-2.7	-1.9
Overall length with bucket on ground	mm	4019	4019	3962
	in	158.2	158.2	156.0
Front clearance circle radius (with bucket)	mm	2415	2448	2364
	in	95.1	96.4	93.1
Tipping load	kg	3930.7	3908.2	4235.0
	lb	8666	8616	9336
Breakout force — lift	kg	2503.1	2482.9	2682.4
	lb	5518	5474	5914
Breakout force — tilt	kg	2919.2	2907.0	3199.0
	lb	6436	6409	7052
Operating weight	kg	5157.5	5181.5	4992.1
	lb	11,370	11,423	11,006

Work Tool	Pallet Fork		
Tine Length	910 mm (36")	1070 mm (42")	1220 mm (48")
Tire Size	10 x 16.5	10 x 16.5	10 x 16.5
Carriage Assembly No.	353-1694	353-1696	353-1697
Carriage overall width without step	mm	1160	1160
	in	45.7	45.7
Carriage step additional width	mm	106	106
	in	4.2	4.2
Carriage height above blade top	mm	926	926
	in	36.5	36.5
Blade surface height at maximum height	mm	3116	3112
	in	122.7	122.5
Shank front face reach at maximum height	mm	707	708
	in	27.8	27.9
Blade surface height at level lift arms	mm	1432	1429
	in	56.4	56.3
Shank front face reach at level lift arms	mm	734	734
	in	28.9	28.9
Blade surface height at minimum lift	mm	52	49
	in	2.0	1.9
Shank front face reach at minimum lift	mm	406	406
	in	16.0	16.0
Overall length at minimum lift, level tine	mm	4308	4467
	in	169.6	175.9
Tipping load	kg	3381.9	3209.8
	lb	7456	7076
Operating weight	kg	4902.8	4913.1
	lb	10,809	10,831

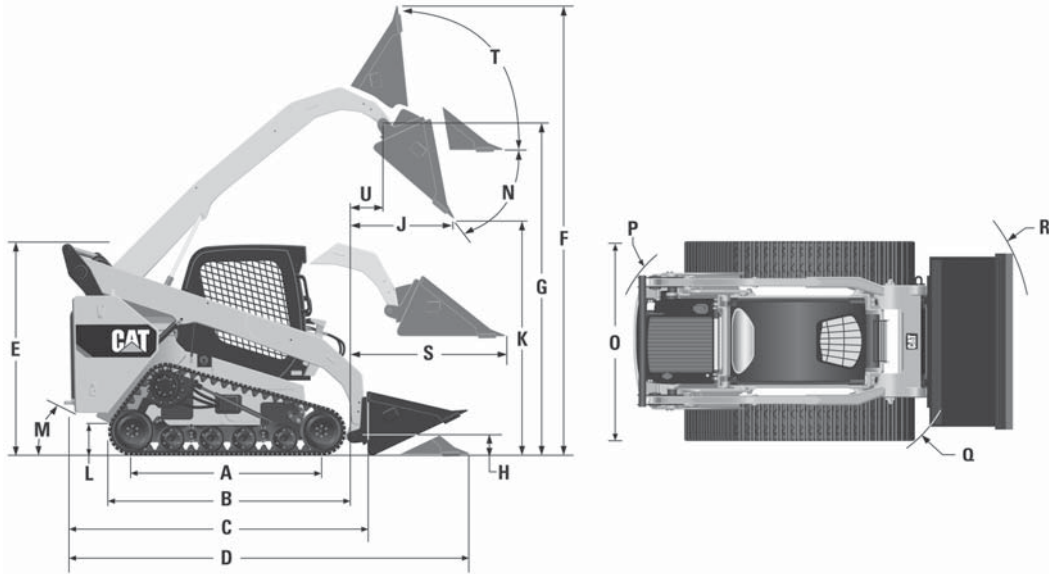

MODEL	257D		277D		287D	
Operating weight	3651 kg	8048 lb	4215 kg	9293 lb	4504 kg	9929 lb
Rated operating capacity at 35%	889 kg	1960 lb	1045 kg	2303 lb	1270 kg	2800 lb
Rated operating capacity at 50%	1270 kg	2800 lb	1492 kg	3290 lb	1814 kg	4000 lb
Tipping load	2540 kg	5600 lb	2985 kg	6580 lb	3629 kg	8000 lb
Breakout force, tilt cylinder	2284 kg	5035 lb	3304 kg	7285 lb	3307 kg	7291 lb
Ground pressure	31.3 kPa	4.5 psi	25.0 kPa	3.6 psi	26.7 kPa	3.9 psi
A Length of track on ground	1499 mm	59.0"	1807 mm	71.1"	1807 mm	71.1"
B Overall length of track	1898 mm	74.7"	2285 mm	90.0"	2285 mm	90.0"
C Length without bucket	2767 mm	108.9"	2995 mm	117.9"	2995 mm	117.9"
D Length with bucket on ground	3486 mm	137.3"	3714 mm	146.2"	3714 mm	146.2"
E Height to top of cab	2129 mm	83.8"	2113 mm	83.2"	2113 mm	83.2"
F Maximum overall height	3932 mm	154.8"	4052 mm	159.5"	4015 mm	158.1"
G Bucket pin height at maximum lift	3091 mm	121.7"	3174 mm	125.0"	3178 mm	125.1"
H Bucket pin height at carry position	215 mm	8.5"	202 mm	8.0"	190 mm	7.5"
J Reach at maximum lift and dump	637 mm	25.1"	598 mm	23.5"	783 mm	30.8"
K Clearance at maximum lift and dump	2300 mm	90.5"	2488 mm	97.9"	2387 mm	94.0"
L Ground clearance	242 mm	9.5"	226 mm	8.9"	226 mm	8.9"
M Departure angle		35°		38°		38°
N Maximum dump angle		52°		39°		51°
O Vehicle width	1676 mm	66.0"	1981 mm	78.0"	1981 mm	78.0"
P Turning radius from center — machine rear	1555 mm	61.2"	1713 mm	67.4"	1713 mm	67.4"
Q Turning radius from center — coupler	1399 mm	55.1"	1493 mm	58.8"	1493 mm	58.8"
R Turning radius from center — bucket	2191 mm	86.3"	2336 mm	92.0"	2336 mm	92.0"
S Maximum reach with arms parallel to ground	1334 mm	52.5"	1395 mm	54.9"	1292 mm	50.9"
T Rack back angle at maximum height		86°		94°		84°
U Bucket pin reach at maximum lift	367 mm	14.5"	—		391 mm	15.4"

NOTE: Based on 75 kg (165 lb) operator, all fluids, two speed, OROPS, 1981 mm (78") dirt bucket, standard flow hydraulics, mechanical suspension seat, no optional counterweights and manual quick coupler (unless otherwise noted). 257D based on 1676 mm (66") dirt bucket and one speed.

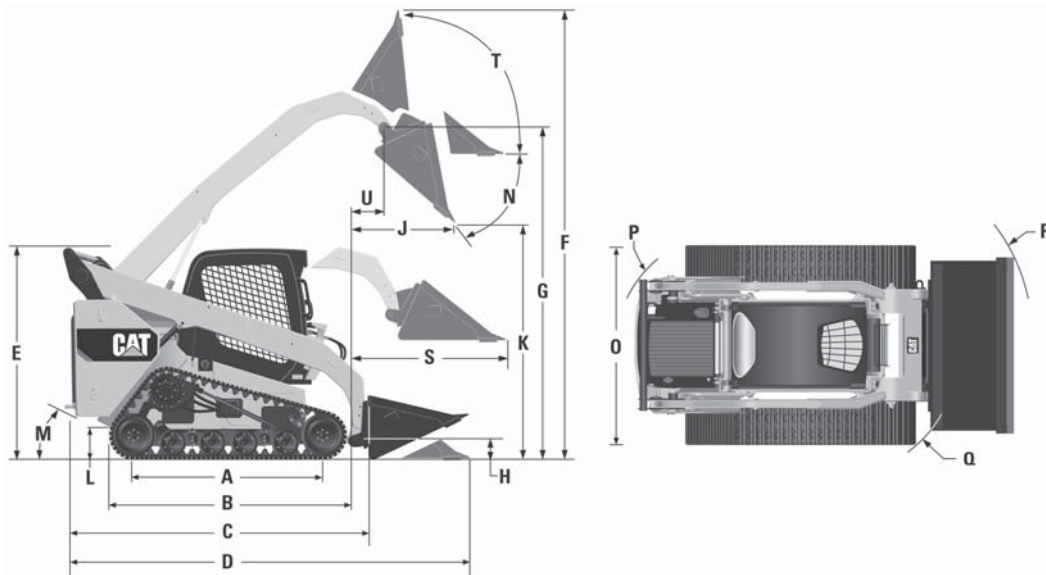

MODEL	297D2		297D2 XHP	
Operating weight	4850 kg	10,692 lb	4952 kg	10,918 lb
Rated operating capacity at 35%	1488 kg	3280 lb	1518 kg	3346 lb
Rated operating capacity at 50%	2125 kg	4685 lb	2168 kg	4780 lb
Tipping load	4250 kg	9371 lb	4336 kg	9560 lb
Breakout force, tilt cylinder	3387 kg	7467 lb	3387 kg	7467 lb
Ground pressure	33.0 kPa	4.8 psi	33.7 kPa	4.9 psi
A Length of track on ground	1807 mm	71.1"	1807 mm	71.1"
B Overall length of track	2286 mm	90.0"	2286 mm	90.0"
C Length without bucket	3201 mm	126.0"	3201 mm	126.0"
D Length with bucket on ground	3942 mm	155.2"	3942 mm	155.2"
E Height to top of cab	2114 mm	83.2"	2114 mm	83.2"
F Maximum overall height	4076 mm	160.5"	4076 mm	160.5"
G Bucket pin height at maximum lift	3241 mm	127.6"	3241 mm	127.6"
H Bucket pin height at carry position	200 mm	7.9"	200 mm	7.9"
J Reach at maximum lift and dump	776 mm	30.5"	776 mm	30.5"
K Clearance at maximum lift and dump	2445 mm	96.3"	2445 mm	96.3"
L Ground clearance	223 mm	8.8"	223 mm	8.8"
M Departure angle		30°		30°
N Maximum dump angle		52°		52°
O Vehicle width	1984 mm	78.1"	1984 mm	78.1"
P Turning radius from center — machine rear	1864 mm	73.4"	1864 mm	73.4"
Q Turning radius from center — coupler	1504 mm	59.2"	1504 mm	59.2"
R Turning radius from center — bucket	2333 mm	91.8"	2333 mm	91.8"
S Maximum reach with arms parallel to ground	1260 mm	49.6"	1260 mm	49.6"
T Rack back angle at maximum height		83°		83°
U Bucket pin reach at maximum lift	387 mm	15.2"	387 mm	15.2"

NOTE: 297D2 based on 75 kg (165 lb) operator, all fluids, two speed, C2 enclosed cab with heat, glass door, 1981 mm (78") dirt bucket, standard flow hydraulics, mechanical suspension seat, no optional counterweights and manual quick coupler (unless otherwise noted).

NOTE: 297D2 XHP based on 75 kg (165 lb) operator, all fluids, two speed, C3 enclosed cab with A/C, glass door, 1981 mm (78") dirt bucket, high flow hydraulics, air suspension seat, no optional counterweights and manual quick coupler (unless otherwise noted).

CAT WORK TOOL COMPATIBILITY

	257D	277D	287D	297D2	297D2 XHP
General Purpose Buckets					
1524 mm (60")	C	C	C	C	C
1676 mm (66")	C	C	C	C	C
1829 mm (72")	C	C	C	C	C
1981 mm (78")	C	C	C	C	C
High Capacity Bucket (GP)					
2134 mm (84")	C	C	C	C	C
Dirt Buckets					
1372 mm (54")	C	C	C	C	C
1524 mm (60")	C	C	C	C	C
1676 mm (66")	C	C	C	C	C
1829 mm (72")	C	C	C	C	C
1981 mm (78")	C	C	C	C	C
Utility Buckets					
1524 mm (60")	C	C	C	C	C
1676 mm (66")	C	C	C	C	C
1829 mm (72")	C	C	C	C	C
Light Material Buckets					
1829 mm (72")	C	C	C	C	C
1981 mm (78")	C	C	C	C	C
2134 mm (84")	C	C	C	C	C
2438 mm (96")	C	C	C	C	C
Multi-Purpose Buckets					
1524 mm (60")	C	C	C	C	C
1676 mm (66")	C	C	C	C	C
1829 mm (72")	C	C	C	C	C
1981 mm (78")	C	C	C	C	C
2134 mm (84")	C	C	C	C	C
Industrial Grapple Buckets					
1524 mm (60")	C	C	C	C	C
1676 mm (66")	C	C	C	C	C
1829 mm (72")	C	C	C	C	C
1981 mm (78")	C	C	C	C	C
Industrial Grapple Forks					
1676 mm (66")	C	C	C	C	C
1829 mm (72")	C	C	C	C	C
Industrial Grapple Rakes					
1829 mm (72")	C	C	C	C	C
2134 mm (84")	C	C	C	C	C
Utility Grapple Buckets					
1676 mm (66")	C	C	C	C	C
1829 mm (72")	C	C	C	C	C

C – Compatible.

CAT WORK TOOL COMPATIBILITY

	257D	277D	287D	297D2	297D2 XHP
Carriage	C	C	C	C	C
Pallet Forks					
910 mm (36") Tines	C	C	C	C	C
1070 mm (42") Tines	C	C	C	C	C
1220 mm (48") Tines	C	C	C	C	C
Utility Grapple Forks					
1676 mm (66")	C	C	C	C	C
1829 mm (72")	C	C	C	C	C
Utility Forks					
1676 mm (66")	C	C	C	C	C
1829 mm (72")	C	C	C	C	C
Angle Blades					
1829 mm (72")	C	C	C	C	C
2134 mm (84")	C	C	C	C	C
Dozer Blades					
2000 mm (79")	C	C	C	C	C
2337 mm (92")	C	C	C	C	C
A14B Auger	C	C	C	C	C
A19B Auger	C	C	C	C	C
A26B Auger	C	C	C	C	C
BH150 Backhoe	C	C	C	C	C
BH160 Backhoe	X	C	C	C	C,R
BR160 Brushcutter	X	X	X	X	X
BR166 Brushcutter	C	C	C	C	C
BR172 Brushcutter	C	C	C	C	C
BR272 Brushcutter	X	X	X	X	X
BR378 Brushcutter	X	C	C	C	C
BP115C Pickup Broom	C	C	C	C	C
BP118C Pickup Broom	C	C	C	C	C
BA118C Angle Broom	C	C	C	C	C
BU115 Utility Broom	C	C	C	C	C
BU118 Utility Broom	C*	C	C	C	C
PC104B Cold Planer	C	C	C	C	C
PC205B Cold Planer	C	C	C	C	C
PC305B Cold Planer	C	C	C	C	C
PC306B Cold Planer	C	C	C	C	C
PC306B XD Cold Planer	X	C*	C	C	C
PC310B Cold Planer	X	C	C	C	C
PC310B XD Cold Planer	X	X	C*	C*	C*
PC408B Cold Planer	X	X	X	X	C
PC412B Cold Planer	X	X	X	X	C

C – Compatible.

C* – Compatible but Lift Restrictions Apply.

R – Machine must have limited options installed to avoid exceeding the maximum total machine rated capacity. Refer to the Operation and Maintenance Manual for the specific Work Tool for details.

X – Not Compatible.

CAT WORK TOOL COMPATIBILITY

	257D	277D	287D	297D2	297D2 XHP
H55E S Hammer	C,D	C,D	C,D	C,D	C,D
H65E S Hammer	C,D	C,D	C,D	C,D	C,D
LR15B Landscape Rake	C*	C	C	C	C
LR18B Landscape Rake	C*	C	C	C	C
LT13B Landscape Tiller	C	C	C	C	C
LT18B Landscape Tiller	C	C	C	C	C
Material Handling Arm	C	C	C	C	C
HM315B Mulcher	X	C	C	C	C
HM415B Mulcher	X	X	X	X	C
PR172 Power Box Rake	C	C	C	C	C
PR184 Power Box Rake	C	C	C	C	C
PR190 Power Box Rake	C	C	C	C	C
S305 Shear	C,D	C,D	C,D	C,D	C,D
Sectional Snow Push 2440 mm (8 ft)	C	C	C	C	C
Sectional Snow Push 3050 mm (10 ft)	C	C	C	C	C
Sectional Snow Push 3660 mm (12 ft)	X	C	C	C	C
Sectional Snow Push 4270 mm (15 ft)	X	X	X	C	C
SR117 Snowblower	X	X	X	X	X
SR118 Snowblower	C	C	C	C	C
SR121 Snowblower	C	C	C	C	C
SR318 Snowblower	C	C	C	C	C
SR321 Snowblower	C	C	C	C	C
SG16B Stump Grinder	C	C	C	C	C
SG18B Stump Grinder	C	C	C	C	C
T6B Trencher	C	C	C	C	C
T9B Trencher	C	C	C	C	C
T15B Trencher	C	C	C	C	C
CV16B Vibratory Compactor	C*	C	C	C	C
CV18B Vibratory Compactor	X	C	C	C	C
SW345B Wheel Saw – 80 mm (3")	C^	C	C	C	C
SW345B Wheel Saw – 130 mm (5")	C*	C	C	C	C
SW360B Wheel Saw – 80 mm (3")	X	C^	C^	C	C
SW360B Wheel Saw – 100 mm (4")	X	C^	C^	C	C
SW360B Wheel Saw – 130 mm (5")	X	C^	C^	C	C
SW360B Wheel Saw – 150 mm (6")	X	C^	C^	C	C
SW360B Wheel Saw – 200 mm (8")	X	C^	C^	C	C
SW460B Wheel Saw – 80 mm (3")	X	X	X	X	C
SW460B Wheel Saw – 150 mm (6")	X	X	X	X	C
SW460B Wheel Saw – 200 mm (8")	X	X	X	X	C
SW380B Wheel Saw – 250 mm (10")	X	C^	C^	C	C
SW480B Wheel Saw – 250 mm (10")	X	X	X	X	C

C – Compatible.

C* – Compatible but Lift Restrictions Apply.

C^ – Compatible but Lift Restrictions Apply and Maximum Machine Counterweights Required.

D – European Union Restrictions Apply; Refer to Operation Maintenance Manual, "Safety Section: Worktools: Demolition."

X – Not Compatible.

MODEL	239D		249D		259D	
Flywheel Power:						
Gross (SAE J1995)	50.1 kW	67.1 hp	50.1 kW	67.1 hp	55.4 kW	74.3 hp
Net (SAE 1349)*	49.1 kW	65.8 hp	49.1 kW	65.8 hp	54.6 kW	73.2 hp
Net (SAE 1349)†	—		—		54.2 kW	72.7 hp
Net (SAE 1349)#	44.0 kW	58.9 hp	44.0 kW	58.9 hp	53.8 kW	72.1 hp
Engine Model	C2.2 CRDI		C2.2 CRDI		C3.3B DIT	
Rated Engine RPM	2800		2800		2400	
Bore	84 mm	3.3"	84 mm	3.3"	94 mm	3.7"
Stroke	100 mm	3.9"	100 mm	3.9"	120 mm	4.7"
Displacement	2.2 L	134.3 in³	2.2 L	134.3 in³	3.3 L	203 in³
No. Cylinders	4		4		4	
One Speed Forward	11.2 km/h	7.0 mph	11.2 km/h	7.0 mph	0-9.5 km/h	0-5.9 mph
Two Speed Forward	—		—		0-13.7 km/h	0-8.5 mph
One Speed Reverse	11.2 km/h	7.0 mph	11.2 km/h	7.0 mph	0-9.5 km/h	0-5.9 mph
Two Speed Reverse	—		—		0-13.7 km/h	0-8.5 mph
Hydraulic Cycle Time, Empty Bucket:	Seconds		Seconds		Seconds	
Raise	2.6		4.4		4.4	
Dump	2.1		2.1		2.4	
Lower (Empty, Float Down)	2.9		6.6		3.6	
Total	7.6		13.1		10.4	
Tread Width (per side)	320 mm	12.6"	320 mm	12.6"	320 mm	12.6"
	400 mm	15.7"	400 mm	15.7"	400 mm	15.7"
Width Over Tracks	1676 mm	66.0"	1676 mm	66.0"	1676 mm	66"
	1756 mm	69.1"	1756 mm	69.1"	1755 mm	69"
Ground Clearance	195 mm	7.7"	195 mm	7.7"	226 mm	8.9"
Fuel Tank Capacity	59 L	15.5 U.S. gal	59 L	15.5 U.S. gal	105 L	27.7 U.S. gal
Hydraulic Tank Capacity	34 L	9.0 U.S. gal	34 L	9.0 U.S. gal	39 L	10.3 U.S. gal
Hydraulic System Capacity (includes tank)	45 L	11.9 U.S. gal	45 L	11.9 U.S. gal	50 L	13.2 U.S. gal
Hydraulic Pump Capacity, Standard	69 L/min	18 gpm	69 L/min	18 gpm	76 L/min	20 gpm
Hydraulic Pressure, Standard	23 000 kPa	3336 psi	23 000 kPa	3336 psi	23 000 kPa	3335 psi
Hydraulic Pump Capacity, High Flow/XPS	99 L/min	26 gpm	99 L/min	26 gpm	112 L/min	30 gpm
Hydraulic Pressure, High Flow/XPS	23 000 kPa	3336 psi	23 000 kPa	3336 psi	23 000 kPa	3335 psi

*Meets Tier 4 Final, Stage IIIB, Japan 2011 (Tier 4 Interim) emission standards.

†Meets Tier 4 Interim, Stage IIIA, Japan 2006 (Tier 3) equivalent emission standards OR Tier 2, Stage II, Japan 2001 (Tier 2) equivalent emission standards.

#Meets Tier 4 Interim, Stage IIIA, Japan 2006 (Tier 3) equivalent emission standards OR Tier 2, Stage II, Japan 2001 (Tier 2) equivalent emission standards.

MODEL	279D		289D		299D2	
Flywheel Power:						
Gross (SAE J1995)	55.4 kW	74.3 hp	55.4 kW	74.3 hp	73.2 kW	98.2 hp
Net (SAE 1349)*	54.6 kW	73.2 hp	54.6 kW	73.2 hp	70.6 kW	94.7 hp
Net (SAE 1349)†	54.0 kW	72.4 hp	54.0 kW	72.4 hp	—	—
Net (SAE 1349)#	53.6 kW	71.8 hp	53.6 kW	71.8 hp	—	—
Engine Model	C3.3B DIT		C3.3B DIT		C3.8 DIT	
Rated Engine RPM	2400		2400		2400	
Bore	94 mm	3.7"	94 mm	3.7"	100 mm	3.9"
Stroke	120 mm	4.7"	120 mm	4.7"	120 mm	4.7"
Displacement	3.3 L	203 in³	3.3 L	203 in³	3.8 L	231.9 in³
No. Cylinders	4		4		4	
One Speed Forward	0-8.4 km/h	0-5.2 mph	0-8.4 km/h	0-5.2 mph	8.4 km/h	5.2 mph
Two Speed Forward	0-13.5 km/h	0-8.4 mph	0-13.5 km/h	0-8.4 mph	13.3 km/h	8.3 mph
One Speed Reverse	0-8.4 km/h	0-5.2 mph	0-8.4 km/h	0-5.2 mph	8.4 km/h	5.2 mph
Two Speed Reverse	0-13.5 km/h	0-8.4 mph	0-13.5 km/h	0-8.4 mph	13.3 km/h	8.3 mph
Hydraulic Cycle Time, Empty Bucket:	Seconds		Seconds		Seconds	
Raise	3.1		4.6		5.2	
Dump	2.5		2.3		2.3	
Lower (Empty, Float Down)	4.0		4.0		4.6	
Total	9.6		10.9		12.1	
Tread Width (per side)	400 mm	15.7"	400 mm	15.7"	400 mm	15.7"
	450 mm	17.7"	450 mm	17.7"	450 mm	17.7"
Width Over Tracks	1931 mm	76"	1931 mm	76"	1931 mm	76.0"
	1981 mm	78"	1981 mm	78"	1981 mm	78.0"
Ground Clearance	226 mm	8.9"	226 mm	8.9"	245 mm	9.6"
Fuel Tank Capacity	94 L	24.8 U.S. gal	94 L	24.8 U.S. gal	122 L	32.2 U.S. gal
Hydraulic Tank Capacity	39 L	10.3 U.S. gal	39 L	10.3 U.S. gal	39 L	10.3 U.S. gal
Hydraulic System Capacity (includes tank)	52 L	13.7 U.S. gal	52 L	13.7 U.S. gal	55 L	14.5 U.S. gal
Hydraulic Pump Capacity, Standard	86 L/min	23 gpm	86 L/min	23 gpm	86 L/min	23 gpm
Hydraulic Pressure, Standard	23 000 kPa	3335 psi	23 000 kPa	3335 psi	23 000 kPa	3336 psi
Hydraulic Pump Capacity, High Flow/XPS	121 L/min	32 gpm	121 L/min	32 gpm	121 L/min	32 gpm
Hydraulic Pressure, High Flow/XPS	28 000 kPa	4061 psi	28 000 kPa	4061 psi	28 000 kPa	4061 psi

*Meets Tier 4 Final, Stage IIIB, Japan 2011 (Tier 4 Interim) emission standards.

†Meets Tier 4 Interim, Stage IIIA, Japan 2006 (Tier 3) equivalent emission standards OR Tier 2, Stage II, Japan 2001 (Tier 2) equivalent emission standards.

#Meets Tier 4 Interim, Stage IIIA, Japan 2006 (Tier 3) equivalent emission standards OR Tier 2, Stage II, Japan 2001 (Tier 2) equivalent emission standards.

● Specifications
● 299D2 XHP/299D2 (Steel Track)/
299D2 XHP (Steel Track)

Compact Track Loaders

MODEL	299D2 XHP		299D2 (Steel Track)		299D2 XHP (Steel Track)	
Flywheel Power:						
Gross (SAE J1995)	82.0 kW	110.0 hp	73.2 kW	98.2 hp	82.0 kW	110.0 hp
Net (SAE 1349)*	79.0 kW	105.9 hp	70.6 kW	94.7 hp	79.0 kW	105.9 hp
Engine Model	C3.8 DITA		C3.8 DIT		C3.8 DITA	
Rated Engine RPM	2400		2400		2400	
Bore	100 mm	3.9"	100 mm	3.9"	100 mm	3.9"
Stroke	120 mm	4.7"	120 mm	4.7"	120 mm	4.7"
Displacement	3.8 L	231.9 in³	3.8 L	231.9 in³	3.8 L	231.9 in³
No. Cylinders	4		4		4	
One Speed Forward	8.4 km/h	5.2 mph	7.8 km/h	4.8 mph	7.8 km/h	4.8 mph
Two Speed Forward	13.3 km/h	8.3 mph	—	—	—	—
One Speed Reverse	8.4 km/h	5.2 mph	7.8 km/h	4.8 mph	7.8 km/h	4.8 mph
Two Speed Reverse	13.3 km/h	8.3 mph	—	—	—	—
Hydraulic CycleTime, Empty Bucket:	Seconds		Seconds		Seconds	
Raise	4.4		5.2		4.4	
Dump	2.0		2.3		2.0	
Lower (Empty, Float Down)	4.7		4.6		4.7	
Total	11.1		12.1		11.1	
Tread Width (per side)	400 mm	15.7"	400 mm	15.7"	400 mm	15.7"
	450 mm	17.7"	450 mm	17.7"	450 mm	17.7"
Width Over Tracks	1931 mm	76.0"	1931 mm	76.0"	1931 mm	76.0"
	1981 mm	78.0"	1981 mm	78.0"	1981 mm	78.0"
Ground Clearance	245 mm	9.6"	245 mm	9.6"	245 mm	9.6"
Fuel Tank Capacity	122 L	32.2 U.S. gal	122 L	32.2 U.S. gal	122 L	32.2 U.S. gal
Hydraulic Tank Capacity	39 L	10.3 U.S. gal	39 L	10.3 U.S. gal	39 L	10.3 U.S. gal
Hydraulic System Capacity (includes tank)	55 L	14.5 U.S. gal	55 L	14.5 U.S. gal	55 L	14.5 U.S. gal
Hydraulic Pump Capacity, Standard	86 L/min	23 gpm	86 L/min	23 gpm	86 L/min	23 gpm
Hydraulic Pressure, Standard	23 000 kPa	3336 psi	23 000 kPa	3336 psi	23 000 kPa	3336 psi
Hydraulic Pump Capacity, High Flow/XPS	—	—	121 L/min	32 gpm	—	—
Hydraulic Pressure, High Flow/XPS	—	—	28 000 kPa	4061 psi	—	—
Hydraulic Pump Capacity, High Flow/XHP	150 L/min	40 gpm	—	—	150 L/min	40 gpm
Hydraulic Pressure, High Flow/XHP	28 000 kPa	4061 psi	—	—	28 000 kPa	4061 psi

*Meets Tier 4 Final, Stage IIIB, Japan 2011 (Tier 4 Interim) emission standards.

Bucket Type		General Purpose: Bolt-on Edge		Multi-Purpose: Bolt-on Edge	
Bucket Width		1680 mm (66")	1830 mm (72")	1680 mm (66")	1830 mm (72")
Ground Engaging Type		Bolt-on Edge	Bolt-on Edge	Bolt-on Edge	Bolt-on Edge
Bucket Assembly No.		279-5369	279-5373	279-5391	279-5399
Rated bucket capacity	m ³	0.40	0.44	0.34	0.37
	yd ³	0.52	0.58	0.44	0.48
Struck capacity	m ³	0.29	0.31	0.25	0.26
	yd ³	0.38	0.41	0.33	0.34
Width	mm	1740	1893	1749	1902
	in	68.5	74.5	68.9	74.9
Dump clearance at maximum lift/dump	mm	1979	1978	1964	1962
	in	77.9	77.9	77.3	77.3
Reach at maximum lift/dump	mm	605	607	617	619
	in	23.8	23.9	24.3	24.4
Floor angle at maximum lift/dump	degrees	-50.5	-50.5	-50.8	-50.8
Floor angle at maximum lift/rack back	degrees	85.3	85.3	85.1	85.1
Clearance at maximum lift/level bucket	mm	2612	2611	2598	2596
	in	102.8	102.8	102.3	102.2
Hinge pin height at maximum lift	mm	2822	2822	2818	2817
	in	111.1	111.1	110.9	110.9
Maximum overall height	mm	3720	3720	3721	3720
	in	146.5	146.4	146.5	146.5
Reach at level lift arm/bucket	mm	1442	1443	1302	1458
	in	56.8	56.8	51.3	57.4
Maximum floor angle at minimum lift	degrees	23.0	23.0	22.8	22.7
Dig depth with level bucket	mm	6	5	-7	-8
	in	0.2	0.2	-0.3	-0.3
Overall length with bucket on ground	mm	3316	3315	3321	3320
	in	130.5	130.5	130.7	130.7
Front clearance circle radius (with bucket)	mm	2146	2178	2153	2185
	in	84.5	85.8	84.8	86.0
Tipping load	kg	1729.3	1712.4	1583.4	1561.5
	lb	3812	3775	3491	3442
Breakout force — lift	kg	1393.9	1380.8	1286.0	1267.7
	lb	3073	3044	2835	2795
Breakout force — tilt	kg	1564.5	1555.5	1504.8	1495.4
	lb	3449	3429	3318	3297
Operating weight	kg	3370.9	3386.4	3504.3	3527.1
	lb	7431	7466	7726	7776

Bucket Type		Dirt: Bolt-on Edge	
		1680 mm (66")	1830 mm (72")
Bucket Width			
Ground Engaging Type		Bolt-on Edge	Bolt-on Edge
Bucket Assembly No.		279-5441	285-6090
Rated bucket capacity	m ³	0.37	0.41
	yd ³	0.48	0.54
Struck capacity	m ³	0.27	0.30
	yd ³	0.35	0.39
Width	mm	1740	1893
	in	68.5	74.5
Dump clearance at maximum lift/dump	mm	2023	2022
	in	79.6	79.6
Reach at maximum lift/dump	mm	572	573
	in	22.5	22.6
Floor angle at maximum lift/dump	degrees	-50.4	-50.5
Floor angle at maximum lift/rack back	degrees	85.4	85.4
Clearance at maximum lift/level bucket	mm	2617	2615
	in	103.0	103.0
Hinge pin height at maximum lift	mm	2823	2823
	in	111.2	111.1
Maximum overall height	mm	3669	3668
	in	144.4	144.4
Reach at level lift arm/bucket	mm	1387	1388
	in	54.6	54.7
Maximum floor angle at minimum lift	degrees	23.1	23.1
Dig depth with level bucket	mm	10	9
	in	0.4	0.4
Overall length with bucket on ground	mm	3263	3263
	in	128.5	128.5
Front clearance circle radius (with bucket)	mm	2101	2134
	in	82.7	84.0
Tipping load	kg	1794.6	1778.3
	lb	3956	3920
Breakout force — lift	kg	1438.4	1424.6
	lb	3171	3141
Breakout force — tilt	kg	1683.8	1674.2
	lb	3712	3691
Operating weight	kg	3348.2	3364.3
	lb	7381	7417

Work Tool		Pallet Fork		
		910 mm (36")	1070 mm (42")	1220 mm (48")
Tine Length				
Carriage Assembly No.		353-1694	353-1696	353-1697
Carriage overall width without step	mm	1160	1160	1160
	in	45.7	45.7	45.7
Carriage step additional width	mm	106	106	106
	in	4.2	4.2	4.2
Carriage height above blade top	mm	926	926	926
	in	36.5	36.5	36.5
Blade surface height at maximum height	mm	2718	2718	2717
	in	107.0	107.0	107.0
Shank front face reach at maximum height	mm	475	477	479
	in	18.7	18.8	18.9
Blade surface height at level lift arms	mm	1426	1425	1422
	in	56.1	56.1	56.0
Shank front face reach at level lift arms	mm	816	817	819
	in	32.1	32.2	32.2
Blade surface height at minimum lift	mm	100	110	109
	in	4.0	4.3	4.3
Shank front face reach at minimum lift	mm	418	418	419
	in	16.5	16.5	16.5
Overall length at minimum lift, level tine	mm	3607	3767	3917
	in	142.0	148.3	154.2
Tipping load	kg	1470.0	1390.3	1321.4
	lb	3241	3065	2913
Operating weight	kg	3292.3	3302.6	3312.2
	lb	7258	7281	7302

Bucket Type		General Purpose: Bolt-on Edge		Multi-Purpose: Bolt-on Edge	
Bucket Width		1680 mm (66")	1830 mm (72")	1680 mm (66")	1830 mm (72")
Ground Engaging Type		Bolt-on Edge	Bolt-on Edge	Bolt-on Edge	Bolt-on Edge
Bucket Assembly No.		279-5369	279-5373	279-5391	279-5399
Rated bucket capacity	m ³	0.40	0.44	0.34	0.37
	yd ³	0.52	0.58	0.44	0.48
Struck capacity	m ³	0.29	0.31	0.25	0.26
	yd ³	0.38	0.41	0.33	0.34
Width	mm	1740	1893	1749	1902
	in	68.5	74.5	68.9	74.9
Dump clearance at maximum lift/dump	mm	2175	2174	2158	2156
	in	85.6	85.6	85.0	84.9
Reach at maximum lift/dump	mm	774	775	788	790
	in	30.5	30.5	31.0	31.1
Floor angle at maximum lift/dump	degrees	-48.2	-48.2	-48.5	-48.5
Floor angle at maximum lift/rack back	degrees	87.5	87.4	87.2	87.1
Clearance at maximum lift/level bucket	mm	2793	2791	2776	2774
	in	110.0	109.9	109.3	109.2
Hinge pin height at maximum lift	mm	3001	3000	2995	2994
	in	118.2	118.1	117.9	117.9
Maximum overall height	mm	3909	3908	3909	3908
	in	153.9	153.9	153.9	153.8
Reach at level lift arm/bucket	mm	1403	1470	1454	1420
	in	55.2	57.9	57.2	55.9
Maximum floor angle at minimum lift	degrees	26.3	26.2	26.0	25.9
Dig depth with level bucket	mm	11	10	-2	-4
	in	0.4	0.4	-0.1	-0.1
Overall length with bucket on ground	mm	3316	3316	3321	3321
	in	130.6	130.6	130.8	130.7
Front clearance circle radius (with bucket)	mm	2136	2168	2143	2175
	in	84.1	85.4	84.4	85.6
Tipping load	kg	1942.6	1925.8	1793.8	1772.0
	lb	4283	4246	3955	3907
Breakout force — lift	kg	1605.8	1592.6	1497.3	1479.0
	lb	3540	3511	3301	3261
Breakout force — tilt	kg	1562.1	1553.0	1502.3	1492.9
	lb	3444	3424	3312	3291
Operating weight	kg	3550.3	3565.8	3683.7	3706.5
	lb	7827	7861	8121	8171

Bucket Type		Dirt: Bolt-on Edge	
		1680 mm (66")	1830 mm (72")
Bucket Width			
Ground Engaging Type		Bolt-on Edge	Bolt-on Edge
Bucket Assembly No.		279-5441	285-6090
Rated bucket capacity	m ³	0.37	0.41
	yd ³	0.48	0.54
Struck capacity	m ³	0.27	0.30
	yd ³	0.35	0.39
Width	mm	1740	1893
	in	68.5	74.5
Dump clearance at maximum lift/dump	mm	2218	2217
	in	87.3	87.3
Reach at maximum lift/dump	mm	738	740
	in	29.1	29.1
Floor angle at maximum lift/dump	degrees	-48.1	-48.2
Floor angle at maximum lift/rack back	degrees	87.5	87.5
Clearance at maximum lift/level bucket	mm	2797	2796
	in	110.1	110.1
Hinge pin height at maximum lift	mm	3003	3002
	in	118.2	118.2
Maximum overall height	mm	3858	3857
	in	151.9	151.8
Reach at level lift arm/bucket	mm	1348	1350
	in	53.1	53.1
Maximum floor angle at minimum lift	degrees	25.9	26.3
Dig depth with level bucket	mm	15	14
	in	0.6	0.5
Overall length with bucket on ground	mm	3264	3263
	in	128.5	128.5
Front clearance circle radius (with bucket)	mm	2092	2125
	in	82.4	83.7
Tipping load	kg	2013.0	1996.8
	lb	4438	4402
Breakout force — lift	kg	1653.5	1639.7
	lb	3645	3615
Breakout force — tilt	kg	1681.2	1671.6
	lb	3706	3685
Operating weight	kg	3527.6	3543.7
	lb	7777	7812

Work Tool		Pallet Fork		
		910 mm (36")	1070 mm (42")	1220 mm (48")
Tine Length		910 mm (36")	1070 mm (42")	1220 mm (48")
Carriage Assembly No.		353-1694	353-1696	353-1697
Carriage overall width without step	mm	1160	1160	1160
	in	45.7	45.7	45.7
Carriage step additional width	mm	106	106	106
	in	4.2	4.2	4.2
Carriage height above blade top	mm	926	926	926
	in	36.5	36.5	36.5
Blade surface height at maximum height	mm	2901	2902	2900
	in	114.2	114.2	114.2
Shank front face reach at maximum height	mm	608	610	612
	in	23.9	24.0	24.1
Blade surface height at level lift arms	mm	1580	1580	1578
	in	62.2	62.2	62.1
Shank front face reach at level lift arms	mm	776	777	779
	in	30.5	30.6	30.7
Blade surface height at minimum lift	mm	118	118	486
	in	4.6	4.7	19.1
Shank front face reach at minimum lift	mm	416	416	399
	in	16.4	16.4	15.7
Overall length at minimum lift, level tine	mm	3607	3767	3900
	in	142.0	148.3	153.5
Tipping load	kg	1640.5	1552.7	1476.8
	lb	3617	3423	3256
Operating weight	kg	3471.7	3482.0	3491.6
	lb	7654	7676	7698

Bucket Type		General Purpose: Bolt-on Edge		Multi-Purpose: Bolt-on Edge	
Bucket Width		1680 mm (66")	1830 mm (72")	1680 mm (66")	1830 mm (72")
Ground Engaging Type		Bolt-on Edge	Bolt-on Edge	Bolt-on Edge	Bolt-on Edge
Bucket Assembly No.		279-5369	279-5373	279-5391	279-5399
Rated bucket capacity	m ³	0.40	0.44	0.34	0.37
	yd ³	0.52	0.58	0.44	0.48
Struck capacity	m ³	0.29	0.31	0.25	0.26
	yd ³	0.38	0.41	0.33	0.34
Width	mm	1740	1893	1749	1902
	in	68.5	74.5	68.9	74.9
Dump clearance at maximum lift/dump	mm	2420	2418	2404	2403
	in	95.3	95.2	94.7	94.6
Reach at maximum lift/dump	mm	653	654	666	668
	in	25.7	25.8	26.2	26.3
Floor angle at maximum lift/dump	degrees	-38.8	-38.8	-39.1	-39.1
Floor angle at maximum lift/rack back	degrees	83.9	83.9	84.1	84.2
Clearance at maximum lift/level bucket	mm	2965	2964	2956	2955
	in	116.7	116.7	116.4	116.3
Hinge pin height at maximum lift	mm	3174	3174	3169	3168
	in	125.0	124.9	124.8	124.7
Maximum overall height	mm	4135	4134	4136	4135
	in	162.8	162.8	162.8	162.8
Reach at level lift arm/bucket	mm	1478	1479	1492	1493
	in	58.2	58.2	58.7	58.8
Maximum floor angle at minimum lift	degrees	23.0	23.0	23.0	23.0
Dig depth with level bucket	mm	-7	-8	-16	-17
	in	-0.3	-0.3	-0.6	-0.7
Overall length with bucket on ground	mm	3777	3777	3783	3783
	in	148.7	148.7	148.9	148.9
Front clearance circle radius (with bucket)	mm	2251	2281	2253	2284
	in	88.6	89.8	88.7	89.9
Tipping load	kg	2450.2	2433.3	2294.5	2272.5
	lb	5402	5364	5059	5010
Breakout force — lift	kg	2007.9	1994.7	1899.0	1880.7
	lb	4427	4398	4187	4146
Breakout force — tilt	kg	2001.3	1992.2	1940.4	1930.8
	lb	4412	4392	4278	4257
Operating weight	kg	4237.5	4253.0	4370.9	4393.7
	lb	9342	9376	9636	9686

Bucket Type		Dirt: Bolt-on Edge	
		1680 mm (66")	1830 mm (72")
Bucket Width			
Ground Engaging Type		Bolt-on Edge	Bolt-on Edge
Bucket Assembly No.		279-5441	285-6090
Rated bucket capacity	m ³	0.37	0.41
	yd ³	0.48	0.54
Struck capacity	m ³	0.27	0.30
	yd ³	0.35	0.39
Width	mm	1740	1893
	in	68.5	74.5
Dump clearance at maximum lift/dump	mm	2456	2455
	in	96.7	96.7
Reach at maximum lift/dump	mm	611	613
	in	24.1	24.1
Floor angle at maximum lift/dump	degrees	-38.8	-38.8
Floor angle at maximum lift/rack back	degrees	83.8	83.9
Clearance at maximum lift/level bucket	mm	2968	2967
	in	116.9	116.8
Hinge pin height at maximum lift	mm	3175	3175
	in	125.0	125.0
Maximum overall height	mm	4083	4082
	in	160.8	160.7
Reach at level lift arm/bucket	mm	1424	1425
	in	56.1	56.1
Maximum floor angle at minimum lift	degrees	23.0	23.0
Dig depth with level bucket	mm	-3	-4
	in	-0.1	-0.2
Overall length with bucket on ground	mm	3725	3724
	in	146.6	146.6
Front clearance circle radius (with bucket)	mm	2204	2235
	in	86.8	88.0
Tipping load	kg	2535.1	2519.2
	lb	5589	5554
Breakout force — lift	kg	2062.0	2048.2
	lb	4546	4515
Breakout force — tilt	kg	2148.2	2138.5
	lb	4736	4715
Operating weight	kg	4214.8	4230.9
	lb	9292	9327

Work Tool		Pallet Fork		
		910 mm (36")	1070 mm (42")	1220 mm (48")
Tine Length				
Carriage Assembly No.		353-1694	353-1696	353-1697
Carriage overall width without step	mm	1160	1160	1160
	in	45.7	45.7	45.7
Carriage step additional width	mm	106	106	106
	in	4.2	4.2	4.2
Carriage height above blade top	mm	926	926	926
	in	36.5	36.5	36.5
Blade surface height at maximum height	mm	2975	2974	2973
	in	117.1	117.1	117.0
Shank front face reach at maximum height	mm	516	518	521
	in	20.3	20.4	20.5
Blade surface height at level lift arms	mm	1426	1425	1424
	in	56.1	56.1	56.0
Shank front face reach at level lift arms	mm	754	755	757
	in	29.7	29.7	29.8
Blade surface height at minimum lift	mm	92	92	90
	in	3.6	3.6	3.6
Shank front face reach at minimum lift	mm	452	453	453
	in	17.8	17.8	17.8
Overall length at minimum lift, level tine	mm	3851	4011	4161
	in	151.6	157.9	163.8
Tipping load	kg	2027.6	1920.2	1827.7
	lb	4470	4233	4029
Operating weight	kg	3958.1	3968.4	3978.0
	lb	8726	8749	8770

Bucket Type		General Purpose: Bolt-on Edge	
		1981 mm (78")	2134 mm (84")
Bucket Width		1981 mm (78")	2134 mm (84")
Tire Size		12 x 16.5	12 x 16.5
Ground Engaging Type		Bolt-on Edge	Bolt-on Edge
Bucket Assembly No.		279-5377	296-8192
Rated bucket capacity	m ³	0.48	0.63
	yd ³	0.63	0.82
Struck capacity	m ³	0.32	0.59
	yd ³	0.42	0.77
Width	mm	2045	2198
	in	80.5	86.5
Dump clearance at maximum lift/dump	mm	2427	2365
	in	95.6	93.1
Reach at maximum lift/dump	mm	615	691
	in	24.2	27.2
Floor angle at maximum lift/dump	degrees	-38.4	-38.5
Floor angle at maximum lift/rack back	degrees	96.5	96.4
Clearance at maximum lift/level bucket	mm	2969	2965
	in	116.9	116.7
Hinge pin height at maximum lift	mm	3178	3177
	in	125.1	125.1
Maximum overall height	mm	4140	4230
	in	163.0	166.6
Reach at level lift arm/bucket	mm	1446	1542
	in	56.9	60.7
Maximum floor angle at minimum lift	degrees	26.2	26.2
Dig depth with level bucket	mm	-3	-6
	in	-0.1	-0.2
Overall length with bucket on ground	mm	3779	3872
	in	148.8	152.4
Front clearance circle radius (with bucket)	mm	2331	2445
	in	91.8	96.2
Tipping load	kg	2769.6	2675.0
	lb	6106	5897
Breakout force — lift	kg	2575.6	2463.7
	lb	5678	5431
Breakout force — tilt	kg	2914.2	2594.6
	lb	6425	5720
Operating weight	kg	4542.6	4579.5
	lb	10,015	10,096

Bucket Type		Multi-Purpose: Bolt-on Edge		Dirt: Bolt-on Edge
Bucket Width		1981 mm (78")	2134 mm (84")	1981 mm (78")
Tire Size		12 x 16.5	12 x 16.5	12 x 16.5
Bucket Assembly No.		Bolt-on Edge	Bolt-on Edge	Bolt-on Edge
Bucket Assembly No.		279-5402	296-8057	268-4083
Rated bucket capacity	m ³	0.40	0.43	0.44
	yd ³	0.52	0.56	0.58
Struck capacity	m ³	0.28	0.30	0.32
	yd ³	0.37	0.39	0.42
Width	mm	2045	2207	2045
	in	80.5	86.9	80.5
Dump clearance at maximum lift/dump	mm	2412	2410	2464
	in	94.9	94.9	97.0
Reach at maximum lift/dump	mm	631	633	574
	in	24.8	24.9	22.6
Floor angle at maximum lift/dump	degrees	-38.7	-38.8	-38.4
Floor angle at maximum lift/rack back	degrees	96.2	96.2	96.5
Clearance at maximum lift/level bucket	mm	2960	2959	2972
	in	116.5	116.5	117.0
Hinge pin height at maximum lift	mm	3173	3172	3179
	in	124.9	124.9	125.2
Maximum overall height	mm	4141	4140	4088
	in	163.0	163.0	160.9
Reach at level lift arm/bucket	mm	1461	1462	1392
	in	57.5	57.6	54.8
Maximum floor angle at minimum lift	degrees	26.2	26.2	26.2
Dig depth with level bucket	mm	-12	-13	1
	in	-0.5	-0.5	0.0
Overall length with bucket on ground	mm	3785	3785	3726
	in	149.0	149.0	146.7
Front clearance circle radius (with bucket)	mm	2334	2368	2286
	in	91.9	93.2	90.0
Tipping load	kg	2613.8	2591.3	2860.0
	lb	5762	5713	6305
Breakout force — lift	kg	2456.5	2436.7	2638.5
	lb	5416	5372	5817
Breakout force — tilt	kg	2844.9	2832.7	3119.7
	lb	6272	6245	6878
Operating weight	kg	4688.9	4712.9	4523.5
	lb	10,337	10,390	9972

Work Tool		Pallet Fork		
Tine Length		910 mm (36")	1070 mm (42")	1220 mm (48")
Tire Size		10 x 16.5	10 x 16.5	10 x 16.5
Carriage Assembly No.		353-1694	353-1696	353-1697
Carriage overall width without step	mm	1160	1160	1160
	in	45.7	45.7	45.7
Carriage step additional width	mm	106	106	106
	in	4.2	4.2	4.2
Carriage height above blade top	mm	926	926	926
	in	36.5	36.5	36.5
Blade surface height at maximum height	mm	2976	2976	2975
	in	117.2	117.2	117.1
Shank front face reach at maximum height	mm	530	531	533
	in	20.9	20.9	21.0
Blade surface height at level lift arms	mm	1396	1396	1394
	in	55.0	54.9	54.9
Shank front face reach at level lift arms	mm	918	918	919
	in	36.1	36.1	36.2
Blade surface height at minimum lift	mm	7	7	6
	in	0.3	0.3	0.2
Shank front face reach at minimum lift	mm	369	369	369
	in	14.5	14.5	14.5
Overall length at minimum lift, level tine	mm	4067	4227	4377
	in	160.1	166.4	172.3
Tipping load	kg	2198.5	2094.8	2004.7
	lb	4847	4618	4420
Operating weight	kg	4434.2	4444.5	4454.1
	lb	9776	9798	9819

Bucket Type		General Purpose: Bolt-on Edge	
		1981 mm (78")	2134 mm (84")
Bucket Width		1981 mm (78")	2134 mm (84")
Tire Size		12 x 16.5	12 x 16.5
Ground Engaging Type		Bolt-on Edge	Bolt-on Edge
Bucket Assembly No.		279-5377	296-8192
Rated bucket capacity	m ³	0.48	0.63
	yd ³	0.63	0.82
Struck capacity	m ³	0.32	0.59
	yd ³	0.42	0.77
Width	mm	2045	2198
	in	80.5	86.5
Dump clearance at maximum lift/dump	mm	2316	2239
	in	91.2	88.2
Reach at maximum lift/dump	mm	784	845
	in	30.9	33.3
Floor angle at maximum lift/dump	degrees	-50.9	-51.0
Floor angle at maximum lift/rack back	degrees	84.0	83.9
Clearance at maximum lift/level bucket	mm	2971	2967
	in	117.0	116.8
Hinge pin height at maximum lift	mm	3181	3178
	in	125.2	125.1
Maximum overall height	mm	4097	4187
	in	161.3	164.8
Reach at level lift arm/bucket	mm	1340	1436
	in	52.7	56.5
Maximum floor angle at minimum lift	degrees	26.2	26.2
Dig depth with level bucket	mm	-18	-22
	in	-0.7	-0.9
Overall length with bucket on ground	mm	3781	3874
	in	148.8	152.5
Front clearance circle radius (with bucket)	mm	2331	2445
	in	91.8	96.2
Tipping load	kg	3203.3	3093.0
	lb	7062	6819
Breakout force — lift	kg	2378.3	2278.4
	lb	5243	5023
Breakout force — tilt	kg	2916.6	2596.8
	lb	6430	5725
Operating weight	kg	4821.0	4857.9
	lb	10,628	10,710

Bucket Type		Multi-Purpose: Bolt-on Edge		Dirt: Bolt-on Edge
Bucket Width		1981 mm (78")	2134 mm (84")	1981 mm (78")
Tire Size		12 x 16.5	12 x 16.5	12 x 16.5
Bucket Assembly No.		Bolt-on Edge	Bolt-on Edge	Bolt-on Edge
Bucket Assembly No.		279-5402	296-8057	268-4083
Rated bucket capacity	m ³	0.40	0.43	0.44
	yd ³	0.52	0.56	0.58
Struck capacity	m ³	0.28	0.30	0.32
	yd ³	0.37	0.39	0.42
Width	mm	2045	2207	2045
	in	80.5	86.9	80.5
Dump clearance at maximum lift/dump	mm	2299	2298	2360
	in	90.5	90.5	92.9
Reach at maximum lift/dump	mm	797	799	751
	in	31.4	31.4	29.6
Floor angle at maximum lift/dump	degrees	-51.2	-51.2	-50.9
Floor angle at maximum lift/rack back	degrees	83.7	83.6	84.0
Clearance at maximum lift/level bucket	mm	2960	2959	2974
	in	116.6	116.5	117.1
Hinge pin height at maximum lift	mm	3174	3172	3182
	in	124.9	124.9	125.3
Maximum overall height	mm	4095	4094	4046
	in	161.2	161.2	159.3
Reach at level lift arm/bucket	mm	1355	1356	1286
	in	53.3	53.4	50.6
Maximum floor angle at minimum lift	degrees	26.2	26.2	26.2
Dig depth with level bucket	mm	-27	-28	-15
	in	-1.1	-1.1	-0.6
Overall length with bucket on ground	mm	3786	3786	3728
	in	149.1	149.1	146.8
Front clearance circle radius (with bucket)	mm	2334	2368	2286
	in	91.9	93.2	90.0
Tipping load	kg	3038.1	3015.5	3302.6
	lb	6698	6648	7281
Breakout force — lift	kg	2257.4	2237.3	2433.9
	lb	4977	4932	5366
Breakout force — tilt	kg	2847.3	2835.1	3122.3
	lb	6277	6250	6883
Operating weight	kg	4967.3	4991.3	4801.9
	lb	10,951	11,004	10,586

Work Tool		Pallet Fork		
Tine Length		910 mm (36")	1070 mm (42")	1220 mm (48")
Tire Size		10 x 16.5	10 x 16.5	10 x 16.5
Carriage Assembly No.		353-1694	353-1696	353-1697
Carriage overall width without step	mm	1160	1160	1160
	in	45.7	45.7	45.7
Carriage step additional width	mm	106	106	106
	in	4.2	4.2	4.2
Carriage height above blade top	mm	926	926	926
	in	36.5	36.5	36.5
Blade surface height at maximum height	mm	3076	3076	3074
	in	121.1	121.1	121.0
Shank front face reach at maximum height	mm	665	667	669
	in	26.2	26.3	26.4
Blade surface height at level lift arms	mm	1549	1548	1546
	in	61.0	60.9	60.9
Shank front face reach at level lift arms	mm	715	716	717
	in	28.1	28.2	28.2
Blade surface height at minimum lift	mm	85	84	83
	in	3.3	3.3	3.3
Shank front face reach at minimum lift	mm	381	381	382
	in	15.0	15.0	15.0
Overall length at minimum lift, level tine	mm	4069	4229	4379
	in	160.2	166.5	172.4
Tipping load	kg	2756.1	2619.6	2501.8
	lb	6076	5775	5515
Operating weight	kg	4712.6	4722.9	4732.5
	lb	10,389	10,412	10,433

Bucket Type		General Purpose: Bolt-on Edge	
		1981 mm (78")	2134 mm (84")
Bucket Width			
Ground Engaging Type		Bolt-on Edge	Bolt-on Edge
Bucket Assembly No.		279-5377	296-8192
Rated bucket capacity	m ³	0.48	0.63
	yd ³	0.63	0.82
Struck capacity	m ³	0.32	0.59
	yd ³	0.42	0.77
Width	mm	2045	2198
	in	80.5	86.5
Dump clearance at maximum lift/dump	mm	2319	2240
	in	91.3	88.2
Reach at maximum lift/dump	mm	890	947
	in	35.0	37.3
Floor angle at maximum lift/dump	degrees	-53.7	-53.8
Floor angle at maximum lift/rack back	degrees	81.3	81.2
Clearance at maximum lift/level bucket	mm	2973	2966
	in	117.1	116.8
Hinge pin height at maximum lift	mm	3205	3203
	in	126.2	126.1
Maximum overall height	mm	4105	4195
	in	161.6	165.2
Reach at level lift arm/bucket	mm	1403	1498
	in	55.2	59.0
Maximum floor angle at minimum lift	degrees	25.0	25.0
Dig depth with level bucket	mm	-73	-79
	in	-2.9	-3.1
Overall length with bucket on ground	mm	4000	4093
	in	157.5	161.1
Front clearance circle radius (with bucket)	mm	2388	2498
	in	94.0	98.4
Tipping load	kg	3944.3	3822.3
	lb	8696	8427
Breakout force — lift	kg	2668.9	2563.7
	lb	5884	5652
Breakout force — tilt	kg	2908.3	2589.2
	lb	6412	5708
Operating weight	kg	5173.5	5210.4
	lb	11,405	11,487

Bucket Type		Multi-Purpose: Bolt-on Edge		Dirt: Bolt-on Edge
		1981 mm (78")	2134 mm (84")	1981 mm (78")
Bucket Width				
Bucket Assembly No.		Bolt-on Edge	Bolt-on Edge	Bolt-on Edge
Bucket Assembly No.		279-5402	296-8057	268-4083
Rated bucket capacity	m ³	0.40	0.43	0.44
	yd ³	0.52	0.56	0.58
Struck capacity	m ³	0.28	0.30	0.32
	yd ³	0.37	0.39	0.42
Width	mm	2045	2207	2045
	in	80.5	86.9	80.5
Dump clearance at maximum lift/dump	mm	2302	2301	2365
	in	90.6	90.6	93.1
Reach at maximum lift/dump	mm	902	904	859
	in	35.5	35.6	33.8
Floor angle at maximum lift/dump	degrees	-54.0	-54.0	-53.7
Floor angle at maximum lift/rack back	degrees	81.0	81.0	81.3
Clearance at maximum lift/level bucket	mm	2957	2955	2979
	in	116.4	116.3	117.3
Hinge pin height at maximum lift	mm	3198	3197	3206
	in	125.9	125.9	126.2
Maximum overall height	mm	4104	4102	4055
	in	161.6	161.5	159.6
Reach at level lift arm/bucket	mm	1389	1416	1349
	in	54.7	55.8	53.1
Maximum floor angle at minimum lift	degrees	24.8	24.8	25.1
Dig depth with level bucket	mm	-85	-86	-68
	in	-3.3	-3.4	-2.7
Overall length with bucket on ground	mm	4004	4004	3948
	in	157.7	157.6	155.4
Front clearance circle radius (with bucket)	mm	2395	2429	2344
	in	94.3	95.6	92.3
Tipping load	kg	3774.2	3751.6	4068.5
	lb	8321	8271	8969
Breakout force — lift	kg	2547.3	2527.1	2727.6
	lb	5616	5571	6013
Breakout force — tilt	kg	2839.0	2826.8	3113.5
	lb	6259	6232	6864
Operating weight	kg	5319.8	5343.8	5154.4
	lb	11,728	11,781	11,363

Work Tool		Pallet Fork		
		910 mm (36")	1070 mm (42")	1220 mm (48")
Tine Length				
Carriage Assembly No.		353-1694	353-1696	353-1697
Carriage overall width without step	mm	1160	1160	1160
	in	45.7	45.7	45.7
Carriage step additional width	mm	106	106	106
	in	4.2	4.2	4.2
Carriage height above blade top	mm	926	926	926
	in	36.5	36.5	36.5
Blade surface height at maximum height	mm	3080	3077	3072
	in	121.3	121.1	120.9
Shank front face reach at maximum height	mm	811	813	815
	in	31.9	32.0	32.1
Blade surface height at level lift arms	mm	1398	1395	1390
	in	55.1	54.9	54.7
Shank front face reach at level lift arms	mm	778	779	780
	in	30.6	30.7	30.7
Blade surface height at minimum lift	mm	31	29	25
	in	1.2	1.1	1.0
Shank front face reach at minimum lift	mm	402	402	403
	in	15.8	15.8	15.9
Overall length at minimum lift, level tine	mm	4294	4453	4604
	in	169.0	175.3	181.2
Tipping load	kg	3258.7	3096.5	2956.9
	lb	7184	6827	6519
Operating weight	kg	5065.1	5075.4	5085.0
	lb	11,166	11,189	11,210

Bucket Type		General Purpose: Bolt-on Edge	
		1981 mm (78")	2134 mm (84")
Bucket Width			
Ground Engaging Type		Bolt-on Edge	Bolt-on Edge
Bucket Assembly No.		279-5377	296-8192
Rated bucket capacity	m³	0.48	0.63
	yd³	0.63	0.82
Struck capacity	m³	0.32	0.59
	yd³	0.42	0.77
Width	mm	2045	2198
	in	80.5	86.5
Dump clearance at maximum lift/dump	mm	2319	2240
	in	91.3	88.2
Reach at maximum lift/dump	mm	890	947
	in	35.1	37.3
Floor angle at maximum lift/dump	degrees	-53.7	-53.8
Floor angle at maximum lift/rack back	degrees	81.3	81.2
Clearance at maximum lift/level bucket	mm	2973	2965
	in	117.0	116.7
Hinge pin height at maximum lift	mm	3205	3203
	in	126.2	126.1
Maximum overall height	mm	4105	4195
	in	161.6	165.1
Reach at level lift arm/bucket	mm	1403	1498
	in	55.2	59.0
Maximum floor angle at minimum lift	degrees	25.0	25.0
Dig depth with level bucket	mm	-73	-79
	in	-2.9	-3.1
Overall length with bucket on ground	mm	4000	4093
	in	157.5	161.1
Front clearance circle radius (with bucket)	mm	2388	2498
	in	94.0	98.4
Tipping load	kg	4052.3	3928.2
	lb	8934	8660
Breakout force — lift	kg	2663.7	2558.7
	lb	5872	5641
Breakout force — tilt	kg	2908.3	2589.2
	lb	6412	5708
Operating weight	kg	5324.4	5361.3
	lb	11,738	11,819

Bucket Type		Multi-Purpose: Bolt-on Edge		Dirt: Bolt-on Edge
Bucket Width		1981 mm (78")	2134 mm (84")	1981 mm (78")
Bucket Assembly No.		Bolt-on Edge	Bolt-on Edge	Bolt-on Edge
Bucket Assembly No.		279-5402	296-8057	268-4083
Rated bucket capacity	m ³	0.40	0.43	0.44
	yd ³	0.52	0.56	0.58
Struck capacity	m ³	0.28	0.30	0.32
	yd ³	0.37	0.39	0.42
Width	mm	2045	2207	2045
	in	80.5	86.9	80.5
Dump clearance at maximum lift/dump	mm	2302	2301	2364
	in	90.6	90.6	93.1
Reach at maximum lift/dump	mm	902	904	860
	in	35.5	35.6	33.8
Floor angle at maximum lift/dump	degrees	-54.0	-54.0	-53.7
Floor angle at maximum lift/rack back	degrees	81.0	81.0	81.3
Clearance at maximum lift/level bucket	mm	2957	2955	2978
	in	116.4	116.3	117.3
Hinge pin height at maximum lift	mm	3198	3197	3206
	in	125.9	125.9	126.2
Maximum overall height	mm	4104	4102	4054
	in	161.6	161.5	159.6
Reach at level lift arm/bucket	mm	1415	1416	1349
	in	55.7	55.8	53.1
Maximum floor angle at minimum lift	degrees	24.8	24.8	25.1
Dig depth with level bucket	mm	-85	-87	-69
	in	-3.4	-3.4	-2.7
Overall length with bucket on ground	mm	4004	4004	3948
	in	157.7	157.6	155.4
Front clearance circle radius (with bucket)	mm	2395	2429	2344
	in	94.3	95.6	92.3
Tipping load	kg	3881.1	3858.5	4179.2
	lb	8556	8506	9214
Breakout force — lift	kg	2542.1	2522.0	2722.4
	lb	5604	5560	6002
Breakout force — tilt	kg	2839.0	2826.8	3113.5
	lb	6259	6232	6864
Operating weight	kg	5470.7	5494.7	5305.3
	lb	12,061	12,114	11,696

Work Tool		Pallet Fork		
		910 mm (36")	1070 mm (42")	1220 mm (48")
Tine Length				
Carriage Assembly No.		353-1694	353-1696	353-1697
Carriage overall width without step	mm	1160	1160	1160
	in	45.7	45.7	45.7
Carriage step additional width	mm	106	106	106
	in	4.2	4.2	4.2
Carriage height above blade top	mm	926	926	926
	in	36.5	36.5	36.5
Blade surface height at maximum height	mm	3080	3076	3071
	in	121.2	121.1	120.9
Shank front face reach at maximum height	mm	812	814	816
	in	32.0	32.0	32.1
Blade surface height at level lift arms	mm	1398	1394	1390
	in	55.0	54.9	54.7
Shank front face reach at level lift arms	mm	778	779	780
	in	30.6	30.7	30.7
Blade surface height at minimum lift	mm	31	28	24
	in	1.2	1.1	0.9
Shank front face reach at minimum lift	mm	402	402	403
	in	15.8	15.8	15.9
Overall length at minimum lift, level tine	mm	4293	4453	4604
	in	169.0	175.3	181.2
Tipping load	kg	3345.4	3179.2	3036.1
	lb	7375	7009	6693
Operating weight	kg	5216.0	5226.3	5235.9
	lb	11,499	11,522	11,543

Bucket Type		General Purpose: Bolt-on Edge	
		1981 mm (78")	2134 mm (84")
Bucket Width			
Ground Engaging Type		Bolt-on Edge	Bolt-on Edge
Bucket Assembly No.		279-5377	296-8192
Rated bucket capacity	m ³	0.48	0.63
	yd ³	0.63	0.82
Struck capacity	m ³	0.32	0.59
	yd ³	0.42	0.77
Width	mm	2045	2198
	in	80.5	86.5
Dump clearance at maximum lift/dump	mm	2310	2232
	in	91.0	87.9
Reach at maximum lift/dump	mm	901	956
	in	35.5	37.6
Floor angle at maximum lift/dump	degrees	-54.0	-54.0
Floor angle at maximum lift/rack back	degrees	81.0	81.0
Clearance at maximum lift/level bucket	mm	2963	2957
	in	116.7	116.4
Hinge pin height at maximum lift	mm	3197	3196
	in	125.9	125.8
Maximum overall height	mm	4096	4187
	in	161.3	164.8
Reach at level lift arm/bucket	mm	1409	1503
	in	55.5	59.2
Maximum floor angle at minimum lift	degrees	24.7	24.7
Dig depth with level bucket	mm	-84	-90
	in	-3.3	-3.5
Overall length with bucket on ground	mm	3997	4089
	in	157.3	161.0
Front clearance circle radius (with bucket)	mm	2388	2498
	in	94.0	98.4
Tipping load	kg	4273.9	4145.3
	lb	9422	9139
Breakout force — lift	kg	2668.9	2563.7
	lb	5884	5652
Breakout force — tilt	kg	2908.3	2589.2
	lb	6412	5708
Operating weight	kg	5527.4	5564.3
	lb	12,186	12,267

Bucket Type		Multi-Purpose: Bolt-on Edge		Dirt: Bolt-on Edge
Bucket Width		1981 mm (78")	2134 mm (84")	1981 mm (78")
Bucket Assembly No.		Bolt-on Edge	Bolt-on Edge	Bolt-on Edge
Bucket Assembly No.		279-5402	296-8057	268-4083
Rated bucket capacity	m ³	0.40	0.43	0.44
	yd ³	0.52	0.56	0.58
Struck capacity	m ³	0.28	0.30	0.32
	yd ³	0.37	0.39	0.42
Width	mm	2045	2207	2045
	in	80.5	86.9	80.5
Dump clearance at maximum lift/dump	mm	2298	2297	2355
	in	90.5	90.4	92.7
Reach at maximum lift/dump	mm	908	909	871
	in	35.7	35.8	34.3
Floor angle at maximum lift/dump	degrees	-54.1	-54.1	-53.9
Floor angle at maximum lift/rack back	degrees	80.9	80.9	81.0
Clearance at maximum lift/level bucket	mm	2953	2952	2968
	in	116.3	116.2	116.8
Hinge pin height at maximum lift	mm	3194	3193	3198
	in	125.7	125.7	125.9
Maximum overall height	mm	4098	4098	4045
	in	161.3	161.3	159.2
Reach at level lift arm/bucket	mm	1419	1419	1355
	in	55.9	55.9	53.4
Maximum floor angle at minimum lift	degrees	24.6	24.6	24.8
Dig depth with level bucket	mm	-92	-93	-80
	in	-3.6	-3.7	-3.1
Overall length with bucket on ground	mm	4002	4002	3944
	in	157.6	157.6	155.3
Front clearance circle radius (with bucket)	mm	2395	2429	2344
	in	94.3	95.6	92.3
Tipping load	kg	4099.4	4076.5	4408.7
	lb	9038	8987	9719
Breakout force — lift	kg	2547.3	2527.1	2727.6
	lb	5616	5571	6013
Breakout force — tilt	kg	2839.0	2826.8	3113.5
	lb	6259	6232	6864
Operating weight	kg	5673.7	5697.7	5508.3
	lb	12,508	12,561	12,144

Work Tool		Pallet Fork		
		910 mm (36")	1070 mm (42")	1220 mm (48")
Tine Length				
Carriage Assembly No.		353-1694	353-1696	353-1697
Carriage overall width without step	mm	1160	1160	1160
	in	45.7	45.7	45.7
Carriage step additional width	mm	106	106	106
	in	4.2	4.2	4.2
Carriage height above blade top	mm	926	926	926
	in	36.5	36.5	36.5
Blade surface height at maximum height	mm	3063	3059	3054
	in	120.6	120.4	120.3
Shank front face reach at maximum height	mm	831	831	833
	in	32.7	32.7	32.8
Blade surface height at level lift arms	mm	1381	1377	1372
	in	54.4	54.2	54.0
Shank front face reach at level lift arms	mm	787	788	789
	in	31.0	31.0	31.0
Blade surface height at minimum lift	mm	14	11	8
	in	0.6	0.4	0.3
Shank front face reach at minimum lift	mm	403	403	404
	in	15.9	15.9	15.9
Overall length at minimum lift, level tine	mm	4289	4449	4600
	in	168.9	175.2	181.1
Tipping load	kg	3498.9	3324.6	3174.7
	lb	7714	7329	6999
Operating weight	kg	5419.0	5429.3	5438.9
	lb	11,947	11,969	11,991

Bucket Type		General Purpose: Bolt-on Edge	
		1981 mm (78")	2134 mm (84")
Bucket Width		1981 mm (78")	2134 mm (84")
Ground Engaging Type		Bolt-on Edge	Bolt-on Edge
Bucket Assembly No.		279-5377	296-8192
Rated bucket capacity	m ³	0.48	0.63
	yd ³	0.63	0.82
Struck capacity	m ³	0.32	0.59
	yd ³	0.42	0.77
Width	mm	2045	2198
	in	80.5	86.5
Dump clearance at maximum lift/dump	mm	2310	2233
	in	91.0	87.9
Reach at maximum lift/dump	mm	901	956
	in	35.5	37.6
Floor angle at maximum lift/dump	degrees	-54.0	-54.0
Floor angle at maximum lift/rack back	degrees	81.0	81.0
Clearance at maximum lift/level bucket	mm	2963	2957
	in	116.7	116.4
Hinge pin height at maximum lift	mm	3197	3196
	in	125.9	125.8
Maximum overall height	mm	4096	4187
	in	161.3	164.8
Reach at level lift arm/bucket	mm	1409	1503
	in	55.5	59.2
Maximum floor angle at minimum lift	degrees	24.7	24.7
Dig depth with level bucket	mm	-84	-89
	in	-3.3	-3.5
Overall length with bucket on ground	mm	3997	4089
	in	157.3	161.0
Front clearance circle radius (with bucket)	mm	2388	2498
	in	94.0	98.4
Tipping load	kg	4354.7	4224.4
	lb	9600	9313
Breakout force — lift	kg	2663.7	2558.7
	lb	5872	5641
Breakout force — tilt	kg	2908.3	2589.2
	lb	6412	5708
Operating weight	kg	5629.7	5666.6
	lb	12,411	12,493

Bucket Type	Multi-Purpose: Bolt-on Edge		Dirt: Bolt-on Edge
Bucket Width	1981 mm (78")	2134 mm (84")	1981 mm (78")
Bucket Assembly No.	Bolt-on Edge	Bolt-on Edge	Bolt-on Edge
Bucket Assembly No.	279-5402	296-8057	268-4083
Rated bucket capacity	m ³	0.40	0.43
	yd ³	0.52	0.56
Struck capacity	m ³	0.28	0.30
	yd ³	0.37	0.39
Width	mm	2045	2207
	in	80.5	86.9
Dump clearance at maximum lift/dump	mm	2298	2297
	in	90.5	90.4
Reach at maximum lift/dump	mm	908	908
	in	35.7	35.8
Floor angle at maximum lift/dump	degrees	-54.1	-54.1
Floor angle at maximum lift/rack back	degrees	80.9	80.9
Clearance at maximum lift/level bucket	mm	2954	2953
	in	116.3	116.2
Hinge pin height at maximum lift	mm	3194	3193
	in	125.7	125.7
Maximum overall height	mm	4098	4098
	in	161.4	161.3
Reach at level lift arm/bucket	mm	1418	1419
	in	55.8	55.9
Maximum floor angle at minimum lift	degrees	24.6	24.6
Dig depth with level bucket	mm	-92	-93
	in	-3.6	-3.7
Overall length with bucket on ground	mm	4002	4002
	in	157.6	157.6
Front clearance circle radius (with bucket)	mm	2395	2429
	in	94.3	95.6
Tipping load	kg	4179.3	4156.5
	lb	9214	9163
Breakout force — lift	kg	2542.1	2522.0
	lb	5604	5560
Breakout force — tilt	kg	2839.0	2826.8
	lb	6259	6232
Operating weight	kg	5776.0	5800.0
	lb	12,734	12,787

Work Tool		Pallet Fork		
		910 mm (36")	1070 mm (42")	1220 mm (48")
Tine Length				
Carriage Assembly No.		353-1694	353-1696	353-1697
Carriage overall width without step	mm	1160	1160	1160
	in	45.7	45.7	45.7
Carriage step additional width	mm	106	106	106
	in	4.2	4.2	4.2
Carriage height above blade top	mm	926	926	926
	in	36.5	36.5	36.5
Blade surface height at maximum height	mm	3063	3059	3055
	in	120.6	120.4	120.3
Shank front face reach at maximum height	mm	831	831	833
	in	32.7	32.7	32.8
Blade surface height at level lift arms	mm	1371	1377	1372
	in	54.0	54.2	54.0
Shank front face reach at level lift arms	mm	787	788	789
	in	31.0	31.0	31.0
Blade surface height at minimum lift	mm	14	11	8
	in	0.6	0.4	0.3
Shank front face reach at minimum lift	mm	403	403	404
	in	15.9	15.9	15.9
Overall length at minimum lift, level tine	mm	4289	4449	4600
	in	168.9	175.2	181.1
Tipping load	kg	3563.5	3386.2	3233.7
	lb	7856	7465	7129
Operating weight	kg	5521.3	5531.6	5541.2
	lb	12,172	12,195	12,216

Dimensions

● 239D/249D/259D

Compact Track Loaders

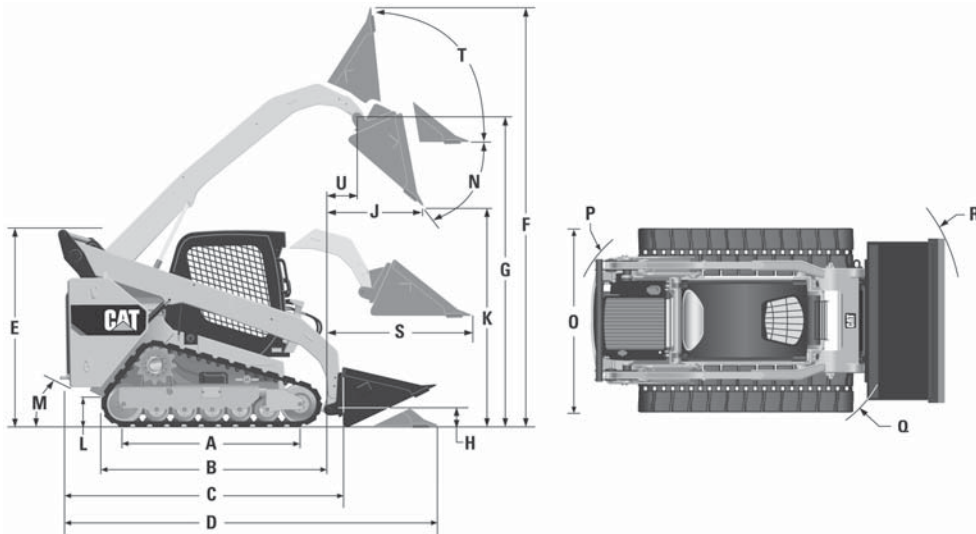

MODEL	239D		249D		259D	
Operating weight	3306 kg	7289 lb	3486 kg	7685 lb	4013 kg	8846 lb
Rated operating capacity at 35%	652 kg	1437 lb	729 kg	1608 lb	921 kg	2030 lb
Rated operating capacity at 50%	931 kg	2053 lb	1042 kg	2297 lb	1315 kg	2900 lb
Tipping load	1863 kg	4107 lb	2084 kg	4594 lb	2631 kg	5800 lb
Breakout force, tilt cylinder	1801 kg	3969 lb	1798 kg	3963 lb	2284 kg	5035 lb
Ground pressure	36.6 kPa	5.3 psi	38.6 kPa	5.6 psi	41.1 kPa	6.0 psi
A Length of track on ground	1384 mm	54.5"	1384 mm	54.5"	1499 mm	59.0"
B Overall length of track	1808 mm	71.2"	1808 mm	71.2"	1999 mm	78.7"
C Length without bucket	2522 mm	99.3"	2523 mm	99.3"	2767 mm	108.9"
D Length with bucket on ground	3234 mm	127.3"	3233 mm	127.3"	3486 mm	137.3"
E Height to top of cab	2034 mm	80.1"	2039 mm	80.3"	2111 mm	83.1"
F Maximum overall height	3645 mm	143.5"	3831 mm	150.8"	3915 mm	154.1"
G Bucket pin height at maximum lift	2825 mm	111.2"	3002 mm	118.2"	3075 mm	121.0"
H Bucket pin height at carry position	218 mm	8.6"	219 mm	8.6"	198 mm	7.8"
J Reach at maximum lift and dump	563 mm	22.2"	727 mm	28.6"	608 mm	23.9"
K Clearance at maximum lift and dump	2057 mm	81.0"	2253 mm	88.7"	2283 mm	89.9"
L Ground clearance	195 mm	7.7"	194 mm	7.6"	226 mm	8.9"
M Departure angle		35°		35°		35°
N Maximum dump angle		50°		48°		52°
O Vehicle width	1676 mm	66.0"	1676 mm	66.0"	1676 mm	66.0"
P Turning radius from center — machine rear	1458 mm	57.4"	1458 mm	57.4"	1561 mm	61.5"
Q Turning radius from center — coupler	1159 mm	45.6"	1160 mm	45.7"	1392 mm	54.8"
R Turning radius from center — bucket	2069 mm	81.5"	2060 mm	81.1"	2184 mm	86.0"
S Maximum reach with arms parallel to ground	1356 mm	53.4"	1317 mm	51.8"	1305 mm	51.4"
T Rack back angle at maximum height		86°		88°		87°
U Bucket pin reach at maximum lift	173 mm	6.8"	311 mm	12.2"	238 mm	9.4"

NOTE: 239D and 249D based on 75 kg (165 lb) operator, all fluids, one speed, OROPS, dual flange front idler/single flange rear idler, standard flow hydraulics, mechanical suspension seat, no optional counterweights and manual quick coupler (unless otherwise noted), 1676 mm (66") dirt bucket and 320 mm (12.6") track.

NOTE: 259D based on 75 kg (165 lb) operator, all fluids, two speed, OROPS, dual flange front idler/single flange rear idler, standard flow hydraulics, mechanical suspension seat, no optional counterweights and manual quick coupler (unless otherwise noted), 1676 mm (66") dirt bucket and 320 mm (12.6") track.

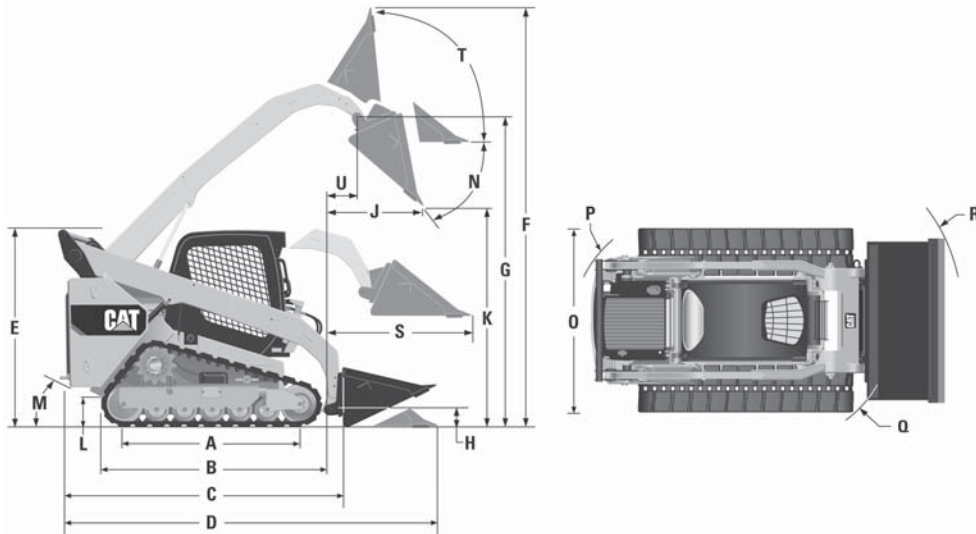

MODEL	279D		289D		299D2	
Operating weight	4487 kg	9893 lb	4778 kg	10,533 lb	5114 kg	11,275 lb
Rated operating capacity at 35%	932 kg	2055 lb	1207 kg	2660 lb	1458 kg	3215 lb
Rated operating capacity at 50%	1331 kg	2935 lb	1724 kg	3800 lb	2083 kg	4592 lb
Tipping load	2663 kg	5870 lb	3447 kg	7600 lb	4166 kg	9184 lb
Breakout force, tilt cylinder	3304 kg	7285 lb	3307 kg	7291 lb	3298 kg	7270 lb
Ground pressure	33.9 kPa	4.9 psi	36.1 kPa	5.2 psi	35.6 kPa	5.2 psi
A Length of track on ground	1630 mm	64.2"	1630 mm	64.2"	1767 mm	69.6"
B Overall length of track	2129 mm	83.8"	2129 mm	83.8"	2270 mm	89.4"
C Length without bucket	2995 mm	117.9"	2995 mm	117.9"	3189 mm	125.5"
D Length with bucket on ground	3714 mm	146.2"	3714 mm	146.2"	3931 mm	154.7"
E Height to top of cab	2113 mm	83.2"	2113 mm	83.2"	2125 mm	83.6"
F Maximum overall height	4051 mm	159.5"	4015 mm	158.1"	4032 mm	158.7"
G Bucket pin height at maximum lift	3173 mm	124.9"	3178 mm	125.1"	3208 mm	126.3"
H Bucket pin height at carry position	198 mm	7.8"	190 mm	7.5"	180 mm	7.1"
J Reach at maximum lift and dump	575 mm	22.6"	761 mm	30.0"	852 mm	33.6"
K Clearance at maximum lift and dump	2485 mm	97.8"	2387 mm	94.0"	2399 mm	94.5"
L Ground clearance	226 mm	8.9"	226 mm	8.9"	245 mm	9.6"
M Departure angle		32°		33°		33°
N Maximum dump angle		39°		51°		54°
O Vehicle width	1931 mm	76.0"	1931 mm	76.0"	1931 mm	76.0"
P Turning radius from center — machine rear	1796 mm	70.7"	1796 mm	70.7"	1881 mm	74.0"
Q Turning radius from center — coupler	1410 mm	55.5"	1410 mm	55.5"	1476 mm	58.1"
R Turning radius from center — bucket	2256 mm	88.8"	2256 mm	88.8"	2314 mm	91.1"
S Maximum reach with arms parallel to ground	1373 mm	54.0"	1270 mm	50.0"	1319 mm	51.9"
T Rack back angle at maximum height		83°		84°		81°
U Bucket pin reach at maximum lift		—	369 mm	14.5"	493 mm	19.4"

NOTE: 279D and 289D based on 75 kg (165 lb) operator, all fluids, two speed, OROPS, dual flange front idler/single flange rear idler, standard flow hydraulics, mechanical suspension seat, no optional counterweights and manual quick coupler (unless otherwise noted), 400 mm (15.7") track and 1981 mm (78") dirt bucket.

NOTE: 299D2 based on 75 kg (165 lb) operator, all fluids, two speed, 1981 mm (78") dirt bucket, 400 mm (15.7") tracks, and manual quick coupler (unless otherwise noted). 299D2 based on dual flange front idler/single flange rear idler, C2 enclosed cab with heat, glass door, standard flow hydraulics, mechanical suspension seat, and no optional counterweights.

Dimensions
 ● 299D2 XHP/299D2 (Steel Track)/
 299D2 XHP (Steel Track)

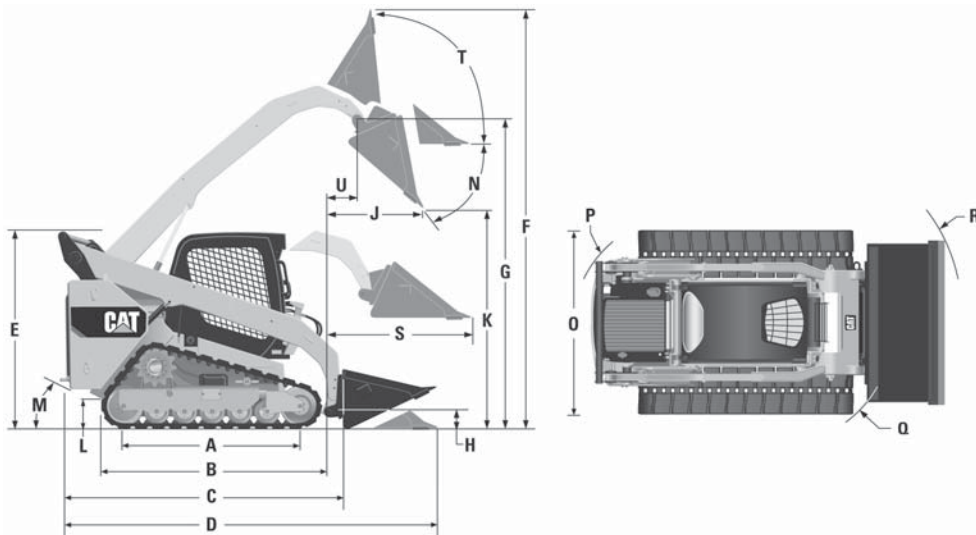

MODEL	299D2 XHP		299D2 (Steel Track)		299D2 XHP (Steel Track)	
Operating weight	5265 kg	11,608 lb	5468 kg	12,055 lb	5571 kg	12,281 lb
Rated operating capacity at 35%	1497 kg	3301 lb	1579 kg	3481 lb	1608 kg	3546 lb
Rated operating capacity at 50%	2139 kg	4716 lb	2256 kg	4973 lb	2298 kg	5065 lb
Tipping load	4278 kg	9431 lb	4511 kg	9946 lb	4595 kg	10,130 lb
Breakout force, tilt cylinder	3298 kg	7270 lb	3298 kg	7270 lb	3298 kg	7270 lb
Ground pressure	36.7 kPa	5.3 psi	38.1 kPa	5.5 psi	38.8 kPa	5.6 psi
A Length of track on ground	1767 mm	69.6"	1767 mm	69.6"	1767 mm	69.6"
B Overall length of track	2270 mm	89.4"	2270 mm	89.4"	2270 mm	89.4"
C Length without bucket	3189 mm	125.5"	3189 mm	125.5"	3189 mm	125.5"
D Length with bucket on ground	3931 mm	154.7"	3931 mm	154.7"	3931 mm	154.7"
E Height to top of cab	2125 mm	83.6"	2125 mm	83.6"	2125 mm	83.6"
F Maximum overall height	4032 mm	158.7"	4032 mm	158.7"	4032 mm	158.7"
G Bucket pin height at maximum lift	3208 mm	126.3"	3208 mm	126.3"	3208 mm	126.3"
H Bucket pin height at carry position	180 mm	7.1"	180 mm	7.1"	180 mm	7.1"
J Reach at maximum lift and dump	852 mm	33.6"	852 mm	33.6"	852 mm	33.6"
K Clearance at maximum lift and dump	2399 mm	94.5"	2399 mm	94.5"	2399 mm	94.5"
L Ground clearance	245 mm	9.6"	245 mm	9.6"	245 mm	9.6"
M Departure angle		33°		33°		33°
N Maximum dump angle		54°		54°		54°
O Vehicle width	1931 mm	76.0"	1931 mm	76.0"	1931 mm	76.0"
P Turning radius from center — machine rear	1881 mm	74.0"	1881 mm	74.0"	1881 mm	74.0"
Q Turning radius from center — coupler	1476 mm	58.1"	1476 mm	58.1"	1476 mm	58.1"
R Turning radius from center — bucket	2314 mm	91.1"	2314 mm	91.1"	2314 mm	91.1"
S Maximum reach with arms parallel to ground	1319 mm	51.9"	1319 mm	51.9"	1319 mm	51.9"
T Rack back angle at maximum height		81°		81°		81°
U Bucket pin reach at maximum lift	493 mm	19.4"	493 mm	19.4"	493 mm	19.4"

NOTE: Based on 75 kg (165 lb) operator, all fluids, two speed, 1981 mm (78") dirt bucket, 400 mm (15.7") tracks, and manual quick coupler (unless otherwise noted). 299D2 based on dual flange front idler/single flange rear idler, C2 enclosed cab with heat, glass door, standard flow hydraulics, mechanical suspension seat, and no optional counterweights. 299D2 XHP based on triple flange front/rear idlers, ride control, C3 enclosed cab A/C and glass door, side windows, and air ride seat.

CAT WORK TOOL COMPATIBILITY

	239D	249D	259D	279D	289D	299D2	299D2 XHP
General Purpose Buckets							
1524 mm (60")	C	C	C	C	C	C	C
1676 mm (66")	C	C	C	C	C	C	C
1829 mm (72")	C	C	C	C	C	C	C
1981 mm (78")	C	C	C	C	C	C	C
High Capacity Bucket (GP)							
2134 mm (84")	C	C	C	C	C	C	C
Dirt Buckets							
1372 mm (54")	C	C	C	C	C	C	C
1524 mm (60")	C	C	C	C	C	C	C
1676 mm (66")	C	C	C	C	C	C	C
1829 mm (72")	C	C	C	C	C	C	C
1981 mm (78")	C	C	C	C	C	C	C
Utility Buckets							
1524 mm (60")	C	C	C	C	C	C	C
1676 mm (66")	C	C	C	C	C	C	C
1829 mm (72")	C	C	C	C	C	C	C
Light Material Buckets							
1829 mm (72")	C	C	C	C	C	C	C
1981 mm (78")	C	C	C	C	C	C	C
2134 mm (84")	C	C	C	C	C	C	C
2438 mm (96")	C	C	C	C	C	C	C
Multi-Purpose Buckets							
1524 mm (60")	C	C	C	C	C	C	C
1676 mm (66")	C	C	C	C	C	C	C
1829 mm (72")	C	C	C	C	C	C	C
1981 mm (78")	C	C	C	C	C	C	C
2134 mm (84")	C	C	C	C	C	C	C
Industrial Grapple Buckets							
1524 mm (60")	C	C	C	C	C	C	C
1676 mm (66")	C	C	C	C	C	C	C
1829 mm (72")	C	C	C	C	C	C	C
1981 mm (78")	C	C	C	C	C	C	C
Industrial Grapple Forks							
1676 mm (66")	C	C	C	C	C	C	C
1829 mm (72")	C	C	C	C	C	C	C
Industrial Grapple Rakes							
1829 mm (72")	C	C	C	C	C	C	C
2134 mm (84")	C	C	C	C	C	C	C
Utility Grapple Buckets							
1676 mm (66")	C	C	C	C	C	C	C
1829 mm (72")	C	C	C	C	C	C	C

C – Compatible.

CAT WORK TOOL COMPATIBILITY

	239D	249D	259D	279D	289D	299D2	299D2 XHP
Carriage	C	C	C	C	C	C	C
Pallet Forks							
910 mm (36") Tines	C	C	C	C	C	C	C
1070 mm (42") Tines	C	C	C	C	C	C	C
1220 mm (48") Tines	C	C	C	C	C	C	C
Utility Grapple Forks							
1676 mm (66")	C	C	C	C	C	C	C
1829 mm (72")	C	C	C	C	C	C	C
Utility Forks							
1676 mm (66")	C	C	C	C	C	C	C
1829 mm (72")	C	C	C	C	C	C	C
Angle Blades							
1829 mm (72")	C	C	C	C	C	C	C
2134 mm (84")	C	C	C	C	C	C	C
Dozer Blades							
2000 mm (79")	C	C	C	C	C	C	C
2337 mm (92")	C	C	C	C	C	C	C
A14B Auger	C	C	C	C	C	C	C
A19B Auger	C	C	C	C	C	C	C
A26B Auger	C	C	C	C	C	C	C
BH150 Backhoe	C	C	C	C	C	C	C
BH160 Backhoe	X	X	X	C	C	C	C,R
BR160 Brushcutter	C	C	X	X	X	X	X
BR166 Brushcutter	X	X	C	C	C	C	C
BR172 Brushcutter	X	X	C	C	C	C	C
BR272 Brushcutter	C	C	X	X	X	X	X
BR378 Brushcutter	X	X	X	C	C	C	C
BP115C Pickup Broom	C	C*	C	C	C	C	C
BP118C Pickup Broom	C*	C*	C*	C	C	C	C
BA118C Angle Broom	C	C	C	C	C	C	C
BU115 Utility Broom	C	C*	C	C	C	C	C
BU118 Utility Broom	C*	C*	C*	C	C	C	C
PC104B Cold Planer	C	C	C	C	C	C	C
PC205B Cold Planer	C	C	C	C	C	C	C
PC305B Cold Planer	C	C	C	C	C	C	C
PC306B Cold Planer	C	C	C	C	C	C	C
PC306B XD Cold Planer	X	X	X	C	C	C	C
PC310B Cold Planer	X	X	X	C	C	C	C
PC310B XD Cold Planer	X	X	X	X	C*,R	C*,R	C*,R
PC408B Cold Planer	X	X	X	X	X	X	C
PC412B Cold Planer	X	X	X	X	X	X	C

C – Compatible.

C* – Compatible but Lift Restrictions Apply.

R – Machine must have limited options installed to avoid exceeding the maximum total machine rated capacity. Refer to the Operation and Maintenance Manual for the specific Work Tool for details.

X – Not Compatible.

CAT WORK TOOL COMPATIBILITY

	239D	249D	259D	279D	289D	299D2	299D2 XHP
H55E S Hammer	C,D	C,D	C,D	C,D	C,D	C,D	C,D
H65E S Hammer	C,D	C,D	C,D	C,D	C,D	C,D	C,D
LR15B Landscape Rake	C*	C*	C*	C	C	C	C
LR18B Landscape Rake	C*	C*	C*	C	C	C	C
LT13B Landscape Tiller	C	C	C	C	C	C	C
LT18B Landscape Tiller	X	C	C	C	C	C	C
Material Handling Arm	C	C	C	C	C	C	C
HM315B Mulcher	X	X	X	C	C	C	C
HM415B Mulcher	X	X	X	X	X	X	C
PR172 Power Box Rake	C	C	C	C	C	C	C
PR184 Power Box Rake	C	C	C	C	C	C	C
PR190 Power Box Rake	C	C	C	C	C	C	C
S305 Shear	C,D	C,D	C,D	C,D	C,D	C,D	C,D
Sectional Snow Push 2440 mm (8 ft)	C	C	C	C	C	C	C
Sectional Snow Push 3050 mm (10 ft)	C	C	C	C	C	C	C
Sectional Snow Push 3660 mm (12 ft)	X	X	X	C	C	C	C
Sectional Snow Push 4270 mm (15 ft)	X	X	X	X	X	C	C
SR117 Snowblower	C	C	X	X	X	X	X
SR118 Snowblower	X	X	C	C	C	C	C
SR121 Snowblower	X	X	C	C	C	C	C
SR318 Snowblower	C	C	C	C	C	C	C
SR321 Snowblower	C	C	C	C	C	C	C
SG16B Stump Grinder	C	C	C	C	C	C	C
SG18B Stump Grinder	C	C	C	C	C	C	C
T6B Trencher	C	C	C	C	C	C	C
T9B Trencher	C	C	C	C	C	C	C
T15B Trencher	C	C	C	C	C	C	C
CV16B Vibratory Compactor	C*	C*	C*	C	C	C	C
CV18B Vibratory Compactor	X	X	X	C	C	C	C
SW345B Wheel Saw – 80 mm (3")	C^	C^	C^	C	C	C	C
SW345B Wheel Saw – 130 mm (5")	C^	C^	C*	C	C	C	C
SW360B Wheel Saw – 80 mm (3")	X	X	X	C^	C^	C	C,R
SW360B Wheel Saw – 100 mm (4")	X	X	X	C^	C^	C	C,R
SW360B Wheel Saw – 130 mm (5")	X	X	X	C^	C^	C	C,R
SW360B Wheel Saw – 150 mm (6")	X	X	X	C^	C^	C	C,R
SW360B Wheel Saw – 200 mm (8")	X	X	X	C^	C^	C	C,R
SW460B Wheel Saw – 80 mm (3")	X	X	X	X	X	X	C,R
SW460B Wheel Saw – 150 mm (6")	X	X	X	X	X	X	C,R
SW460B Wheel Saw – 200 mm (8")	X	X	X	X	X	X	C,R
SW380B Wheel Saw – 250 mm (10")	X	X	X	C^	C^	C	C,R
SW480B Wheel Saw – 250 mm (10")	X	X	X	X	X	X	C,R

C – Compatible.

C* – Compatible but Lift Restrictions Apply.

C^ – Compatible but Lift Restrictions Apply and Maximum Machine Counterweights Required.

R – Machine must have limited options installed to avoid exceeding the maximum total machine rated capacity. Refer to the Operation and Maintenance Manual for the specific Work Tool for details.

D – European Union Restrictions Apply; Refer to Operation Maintenance Manual, "Safety Section: Worktools: Demolition."

X – Not Compatible.

Features:

- **Cat XT™-3 hose and O-ring face seals** are used throughout for superior leak-free performance.
- **Both standard and tree bits are available in a variety of sizes** for a wide range of projects.
- **Standard bit teeth and pilot points** are produced from hardened steel. Optional hardfaced and carbide inserted teeth are also available.
- **Optional bit extension is available** in 305 mm (12") length.
- **Hex-to-round shaft adapter is available** to accommodate existing round auger bit mountings.
- **A14B and A19B** are compatible with both mini hydraulic excavators and skid steer loaders.

A14B Auger

- **Direct drive system** features a variable speed, bidirectional, “Gerotor” style hydraulic motor that generates optimal speed and output torque for light to moderate duty work.

A19B Auger

- **Single reduction planetary drive system** transfers power from the drive motor to the drive shaft, reducing motor speed and increasing torque.
- **Drive motor shaft** is splined and couples directly to the planetary gearbox.

A26B Auger

- **Double reduction planetary drive system** transfers power from the drive motor to the drive shaft, reducing motor speed and increasing torque.
- **Drive motor shaft** is splined and couples directly to the planetary gearbox.

Market Opportunities

- **Agriculture** — Augers are an effective work tool around the farm to drill holes for fence posts, pole barn supports and footers for outbuildings.
- **Building/General Construction** — Augers are an essential work tool on many construction sites to drill holes for deck posts and footings, signs and fencing.

- **Landscaping/Landscape Maintenance** — Augers with special tree bits are ideal for preparing holes for tree planting. They are also ideal for school, park, golf course and recreational maintenance departments to drill holes for playground supports, trees and shrubs, fence posts, and signs.
- **Governmental/Municipalities** — Augers with multiple bit sizes are popular work tools to do a wide spectrum of jobs, including digging holes for traffic signs, poles, posts and trees.
- **Rental** — Augers are one of the highest opportunity rental work tool after buckets.
- **Specialty Trades/Utility** — Augers are ideal for electrical, fencing and plumbing contractors when installing lighting, fence posts and gas/water mains.

Augers are typically not a full time work tool, however they are a highly utilized option for specialized applications. They are often used in conjunction with a bucket, set of pallet forks and/or a trencher.

Auger Bits

Auger bits are available in standard duty, industrial duty, standard rock drill head and tree bit configurations with standard hardened, reversible teeth and cast/hardened pilot point. Optional hard-faced and carbide inserted teeth and pilot points are available for aggressive boring conditions. Standard bits are available in diameters ranging from 6"–36"; industrial bits and standard duty rock drill head bits are available in 6"–24" diameters and tree bits are available in 24" and 36" diameters. Typical digging depth is 48", however for deeper holes, optional 12", 24", 3' and 6' extensions are available. A special HEX to round adapter is also available for customers who use existing round shaft auger bits.

Machine Compatibility

Auger Model	Machine Models
A14B	216B3, 226B3, 226D, 232D, 236D, 239D, 242D, 246D, 249D, 257D, 259D, 262D, 272D2, 272D2 XHP, 277D, 279D, 287D, 289D, 297D2, 297D2 XHP, 299D2, 299D2 XHP
A19B	216B3, 226B3, 226D, 232D, 236D, 239D, 242D, 246D, 249D, 257D, 259D, 262D, 272D2, 272D2 XHP, 277D, 279D, 287D, 289D, 297D2, 297D2 XHP, 299D2, 299D2 XHP
A26B*	226B3, 226D, 232D, 236D, 239D, 242D, 246D, 249D, 257D, 259D, 262D, 272D2, 272D2 XHP, 277D, 279D, 287D, 289D, 297D2, 297D2 XHP, 299D2, 299D2 XHP

*Requires high flow or high flow XPS option on machine.

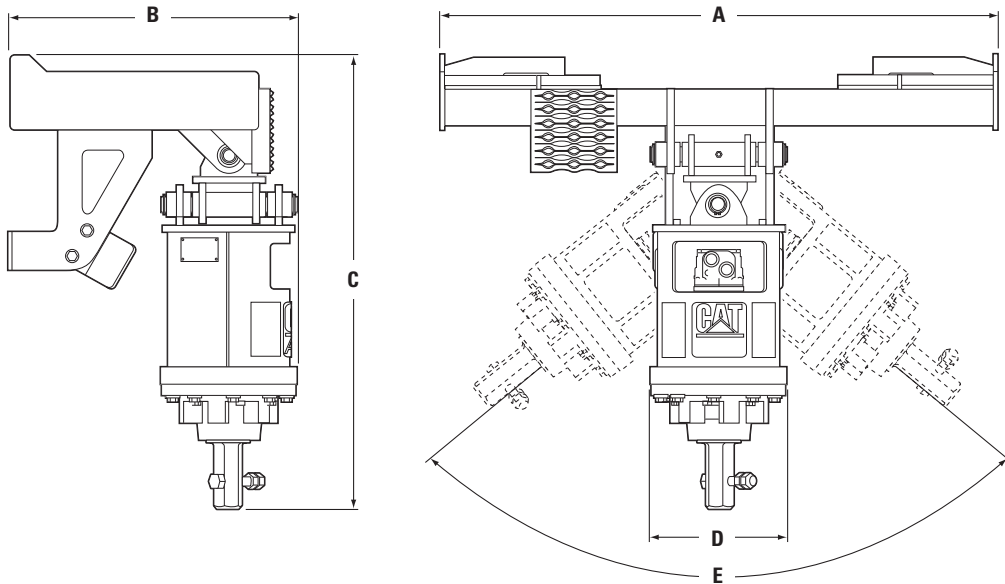

MODEL	A14B		A19B		A26B	
A Overall width with bracket	1152 mm	45"	1152 mm	45"	1152 mm	45"
B Overall length with bracket	593 mm	23"	593 mm	23"	599 mm	24"
C Overall drive unit height	1020 mm	40"	940 mm	37"	978 mm	39"
D Housing diameter	252 mm	10"	252 mm	10"	252 mm	10"
E Swing range	102°		102°		102°	
Drive unit weight with hydraulic lines without bit	84 kg	185 lb	79 kg	174 lb	91 kg	201 lb
Mounting frame weight with clevis	87 kg	192 lb	87 kg	192 lb	91 kg	201 lb
Total weight without bit	171 kg	317 lb	166 kg	366 lb	182 kg	402 lb
Drive method	Gerotor Motor – Direct		Gerotor Motor – Single Planetary Reduction		Gear Motor – Double Planetary Reduction	
Optimal hydraulic flow range	42-86 L/min	11-23 gpm	42-86 L/min	11-23 gpm	95-125 L/min	25-34 gpm
Optimal hydraulic pressure range	145-235 bar	2100-3400 psi	145-235 bar	2100-3400 psi	207-290 bar	3002-4206 psi
Effective displacement	629.1 cm ³ /rev	38.39 in ³ /rev	250 cm ³ /rev	15.26 in ³ /rev	43.77 cm ³ /rev	2.685 in ³ /rev
Drive shaft torque @ maximum pressure*	2304 N·m	1700 lb·ft	4122 N·m	3040 lb·ft	6826 N·m	5034 lb·ft
Bit speed (drive shaft) @ maximum flow	127 RPM		71 RPM		81 RPM	
HEX output shaft size	51 mm	2"	51 mm	2"	51 mm	2"
Auger bit retention method	Cross bolts/nuts		Cross bolts/nuts		Cross bolts/nuts	
Hydraulic hose	Cat XT-3 ES		Cat XT-3 ES		Cat XT-6 ES	

*Theoretical values calculated at 100% efficiency.

A14B Auger

Theoretical Bit Speed			Theoretical Digging Torque			
L/min	gpm	RPM	bar	psi	N-m	lb-ft
42	11	54	145	2100	1764	1300
45	12	59	152	2200	1848	1362
49	13	64	159	2300	1932	1424
53	14	69	166	2400	2016	1486
57	15	74	172	2500	2100	1548
61	16	79	179	2600	2184	1610
64	17	84	186	2700	2268	1672
68	18	89	193	2800	2352	1734
72	19	94	200	2900	2436	1795
76	20	99	207	3000	2520	1857
80	21	104	214	3100	2604	1919
83	22	109	221	3200	2688	1981
87	23	114	228	3300	2772	2043

A19B Auger

Theoretical Bit Speed			Theoretical Digging Torque			
L/min	gpm	RPM	bar	psi	N-m	lb-ft
42	11	38	145	2100	2535	1868
45	12	41	152	2200	2655	1956
49	13	45	159	2300	2776	2045
53	14	48	166	2400	2897	2134
57	15	52	172	2500	3017	2223
61	16	55	179	2600	3138	2312
64	17	59	186	2700	3259	2401
68	18	62	193	2800	3379	2490
72	19	65	200	2900	3500	2579
76	20	69	207	3000	3621	2668
80	21	72	214	3100	3741	2757
83	22	76	221	3200	3862	2846
87	23	79	228	3300	3983	2935

A26B Auger

Theoretical Bit Speed			Theoretical Digging Torque			
L/min	gpm	RPM	bar	psi	N-m	lb-ft
95	25	61	207	3000	4719	3492
99	26	64	214	3100	4880	3611
102	27	66	220	3200	5034	3725
106	28	69	227	3300	5191	3841
110	29	71	234	3400	5348	3958
114	30	74	241	3500	5506	4074
118	31	76	248	3600	5663	4191
121	32	79	255	3700	5820	4307
125	33	81	262	3800	5977	4423
129	34	84	269	3900	6135	4540
133	35	86	276	4000	6292	4656
136	36	88	282	4100	6449	4772
140	37	91	289	4200	6607	4889
144	38	93	296	4300	6764	5005
148	39	96	303	4400	6921	5122
152	40	98	310	4500	7079	5238

Features:

- **High-strength blades** deliver high cutting action and durability, and also mulch overgrowth.
- **Fully balanced blade carriers** prevent unnecessary vibration.
- **High-strength frame with reinforced corner gussets** provide strength in critical areas.
- **Long life motors** deliver years of high-speed blade performance.
- **Machined and heat treated gears** in sealed gearbox provide reliable, durable transfer of torque from motor to blade carrier.
- **Tapered blade carrier** allows cutter to ride up over stumps and rocks.
- **Galvanized coil chains** provide debris guarding in the front and rear areas to restrict flying debris and material.
- **Heavy-duty skids** allow easy movement of the brush-cutter through uneven terrain while maintaining stability of the work tool and machine.
- **Motor protection guard shields** motor and gear box from debris. Removing a set of bolts allows this hinged guard to be moved away for easy access to motor and gear box.
- **Cat XT-3 hose, couplings and O-ring face seals** provide superior, leak-free performance and reliability. All hoses are wrapped with nylon woven cordura sleeving for added operator protection. Hydraulic quick disconnects enable fast tool changes.
- **Quick coupler** with rugged, opposing edge design holds the work tool securely and allows the operator to quickly change from one high performance Cat Work Tool to another.

Cat Brushcutters are used for clearing overgrowth from highway medians, utility easements and for initial land clearing for housing, parks and recreational areas.

Machine Compatibility

Brushcutter Model	Machine Models
BR160	216B3, 226B3, 226D
BR166#	216B3, 226B3, 226D, 232D, 236D, 239D, 242D, 246D, 249D, 257D, 259D, 262D, 272D2, 272D2 XHP, 277D, 279D, 287D, 289D, 297D2, 297D2 XHP, 299D2, 299D2 XHP
BR172#	216B3, 226B3, 226D, 232D, 236D, 239D, 242D, 246D, 249D, 257D, 259D, 262D, 272D2, 272D2 XHP, 277D, 279D, 287D, 289D, 297D2, 297D2 XHP, 299D2, 299D2 XHP
BR272*	226B3, 226D
BR378*#	246D, 262D, 272D2, 272D2 XHP, 277D, 279D, 287D, 289D, 297D2, 297D2 XHP, 299D2, 299D2 XHP

*Requires high flow or high flow XPS option on machine. Operates in high flow XPS on XHP machine.

#Requires a conversion kit for D Series machines.

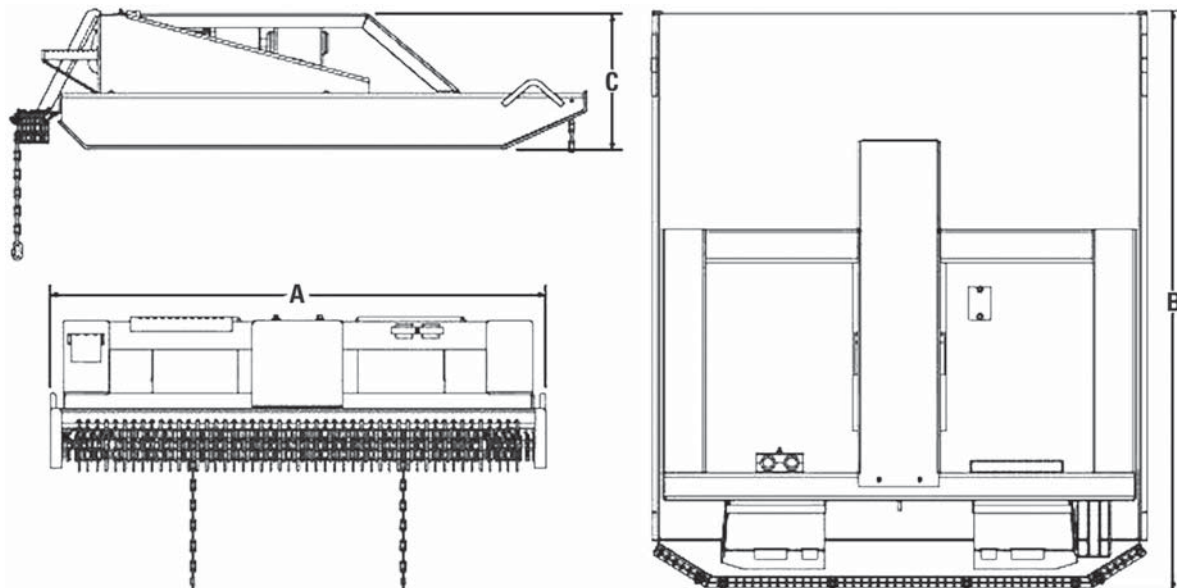

MODEL	BR160		BR166		BR172	
A Overall width	1575 mm	62"	1727 mm	68"	1880 mm	74"
B Overall length	1854 mm	73"	2007 mm	79"	2159 mm	85"
C Overall height	533 mm	21"	533 mm	21"	518 mm	20"
Cutting width	1524 mm	60"	1676 mm	66"	1829 mm	72"
Maximum cutting diameter	76 mm	3"	76 mm	3"	76 mm	3"
Unit weight	431 kg	950 lb	476 kg	1050 lb	499 kg	1100 lb
Optimal hydraulic flow range	57-65 L/min	15-17 gpm	57-80 L/min	15-21 gpm	57-80 L/min	15-21 gpm
Optimal hydraulic pressure range	150-230 bar	2176-3340 psi	150-230 bar	2176-3340 psi	150-230 bar	2176-3340 psi
Tip speed range (depends on flow)	3987-5596 m/min	13,080-18,360 ft/min	3130-4395 m/min	10,270-14,420 ft/min	3417-4795 m/min	11,210-15,730 ft/min

MODEL	BR272		BR378	
A Overall width	1880 mm	74"	2032 mm	80"
B Overall length	2159 mm	85"	2311 mm	91"
C Overall height	518 mm	20"	533 mm	21"
Cutting width	1829 mm	72"	1981 mm	78"
Maximum cutting diameter	76 mm	3"	76 mm	3"
Unit weight	508 kg	1120 lb	535 kg	1180 lb
Optimal hydraulic flow range	76-100 L/min	20-26 gpm	76-130 L/min	20-34 gpm
Optimal hydraulic pressure range	150-230 bar	2176-3340 psi	150-280 bar	2176-4065 psi
Tip speed range (depends on flow)	4554-5992 m/min	14,940-19,660 ft/min	4176-6032 m/min	13,700-19,790 ft/min

Features:

- **Self-leveling design** automatically levels itself when placed on the ground for consistent depth control without operator adjustments and excellent spoil retention.
- **Two wear resistant skid plates** remain parallel to the ground for optimum stability.
- **Hydraulic side-shift** permits close planing to curbs, walls and other obstructions.
- **Independent left/right depth control** allows maximum drum depths to be adjusted independently on each skid. The gauges are easily viewable from the cab. Independent depth control is mechanical on standard flow planers and hydraulic on high flow planers.
- **Max Pro Pressure gauge** provides operator feedback to adjust speed for maximum productivity in changing material loads. Gauge displays planer performance in real-time conditions and is visible from the cab. Standard on XHP models.
- **Float, spring tilt and hydraulic tilt** enables planers to follow the contour of the surface. Float is activated by a knob and is only available on high flow and XHP planers. Spring tilt and hydraulic tilt enable planers to oscillate for angled cuts. Tilt is hydraulically controlled on high flow models and spring controlled on standard flow planers.
- **Direct drive on standard flow** models features a variable speed, unidirectional, gerotor style hydraulic motor.
- **Direct drive on high flow and XHP** models features a hydraulic radial piston motor to ensure maximum cutting rate and drum torque for optimal production performance and efficiency.
- **Optional concrete bits and water sprinkler kits** are available for all models.
- **Cat XT-3 and medium pressure hose, couplings and O-ring face seals** provide superior, leak-free performance and reliability.
- **Quick coupler** with rugged, opposing edge design holds the work tool securely and allows the operator to quickly change from one high performance Cat Work Tool to another.

Conical Bits: Cold planer drums are designed with an optimal bit pattern to provide maximum cutting performance and efficiency, while ensuring superior surface texture. Standard all-purpose tungsten carbide inserted conical bits provide all-purpose planing in most applications.

Market Opportunities

- **Infrastructure/Heavy Construction** — Skid steer mounted cold planers are frequently used on bridges to remove pavement where large dedicated planers are restricted due to weight.
- **Concrete/Masonry (Including Asphalt/Paving)** — Cold planers are used extensively by paving contractors in urban and rural settings to remove damaged pavement prior to overlay, remove excess pavement, provide specific surface texture (skid resistance), remove traffic lane stripes and re-establish proper draining characteristics of pavement.
- **Governmental/Municipalities (Street and Road Maintenance)** — Cold planers are ideal for urban road and parking lot maintenance departments to remove cracked or deteriorated pavement, milling bumps or imperfections in expanded pavement.

Cold planers are highly utilized work tools for specialized applications. They are often used in conjunction with a bucket and broom.

Machine Compatibility

Cold Planer Model	Machine Models
PC104B	216B3, 226B3, 226D, 232D, 236D, 239D, 242D, 246D, 249D, 257D, 259D, 262D, 272D2, 272D2 XHP, 277D, 279D, 287D, 289D, 297D2, 297D2 XHP, 299D2, 299D2 XHP
PC205B*	216B3, 226B3, 226D, 232D, 236D, 239D, 242D, 246D, 249D, 257D, 259D, 262D, 272D2, 272D2 XHP, 277D, 279D, 287D, 289D, 297D2, 297D2 XHP, 299D2, 299D2 XHP
PC305B#	226B3, 226D, 232D, 236D, 239D, 242D, 246D, 249D, 257D, 259D, 262D, 272D2, 272D2 XHP, 277D, 279D, 287D, 289D, 297D2, 297D2 XHP, 299D2, 299D2 XHP
PC306B#	226B3, 226D, 232D, 236D, 239D, 242D, 246D, 249D, 257D, 259D, 262D, 272D2, 272D2 XHP, 277D, 279D, 287D, 289D, 297D2, 297D2 XHP, 299D2, 299D2 XHP
PC310B#	246D, 257D, 259D, 262D, 272D2, 272D2 XHP, 277D, 279D, 287D, 289D, 297D2, 297D2 XHP, 299D2, 299D2 XHP
PC408B	272D2 XHP, 297D2 XHP, 299D2 XHP
PC412B	272D2 XHP, 297D2 XHP, 299D2 XHP

*Requires high flow option on machine. Operates in standard flow on high flow XPS or XHP option machines.

#Requires high flow XPS option on machine. Operates in high flow XPS on XHP machines.

Skid Steer Loaders
Multi Terrain Loaders
Compact Track Loaders

WorkTools
● Cold Planers

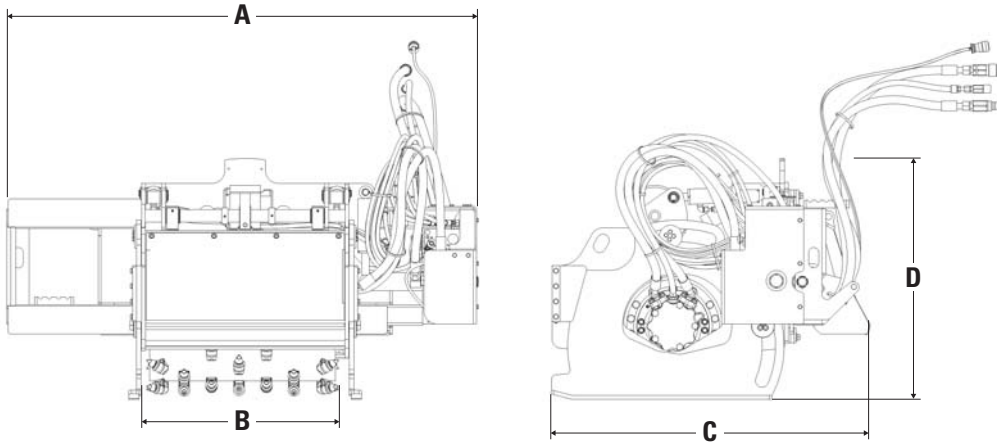

MODEL	PC104B		PC205B	
A Overall width	1730 mm	68"	1730 mm	68"
B Maximum drum width	350 mm	14"	450 mm	18"
Optional drum widths (depths)	400 (150) mm	16 (6)"	80 (200) mm	3 (8)"
			152 (200) mm	6 (8)"
			203 (200) mm	8 (8)"
			305 (200) mm	12 (8)"
			350 (200) mm	14 (8)"
			400 (200) mm	16 (8)"
			450 (150) mm	18 (6)"
C Length	1120 mm	44"	1184 mm	47"
D Overall height	950 mm	37"	1080 mm	43"
Weight	670 kg	1474 lb	730 kg	1606 lb
Drive method	Direct drive		Direct drive	
Optimal hydraulic flow range	60-80 L/min	16-21 gpm	80-115 L/min	21-31 gpm
Optimal hydraulic pressure	230 bar	3330 psi	230 bar	3330 psi
Drum torque @ max. pressure	1350 N·m	996 lb-ft	2047 N·m	1510 lb-ft
Drum speed @ max. flow	150-200 RPM		142-205 RPM	
Number of conical bits	42 per 350 mm		48 per 450 mm	
	13.8" drum		18" drum	
Standard bit type	All purpose		All purpose	
Maximum depth of cut	150 mm	6"	150 mm	6"
Tilt angle range	±8.5°		±8.5°	
Side shift travel	650 mm	26"	650 mm	26"

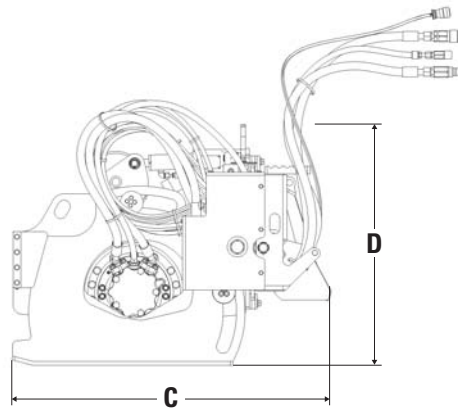
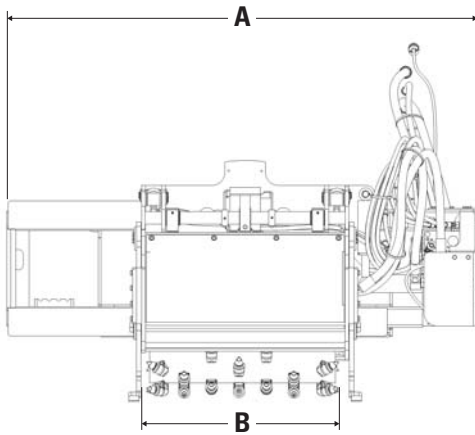

MODEL	PC305B		PC306B	
A Overall width	1858 mm	73"	1858 mm	73"
B Maximum drum width	450 mm	18"	600 mm	24"
Optional drum widths (depths)	80 (200) mm	3 (8)"	80 (200) mm	3 (8)"
	152 (200) mm	6 (8)"	152 (200) mm	6 (8)"
	203 (200) mm	8 (8)"	203 (200) mm	8 (8)"
	305 (200) mm	12 (8)"	305 (200) mm	12 (8)"
	350 (200) mm	14 (8)"	350 (200) mm	14 (8)"
	400 (200) mm	16 (8)"	400 (200) mm	16 (8)"
	450 (150) mm	18 (6)"	450 (150) mm	18 (6)"
	600 (180) mm	24 (7)"	600 (180) mm	24 (7)"
C Length	1240 mm	49"	1240 mm	49"
D Overall height	1100 mm	43"	1100 mm	43"
Weight	860 kg	1896 lb	935 kg	2061 lb
Drive method	Planetary drive		Direct drive	
Optimal hydraulic flow range	100-125 L/min	26-33 gpm	100-125 L/min	26-33 gpm
Optimal hydraulic pressure range	230-280 bar	3330-4000 psi	230-280 bar	3330-4000 psi
Drum torque @ max. pressure	3470 N·m	2558 lb-ft	3470 N·m	2558 lb-ft
Drum speed @ max. flow	160 RPM		160 RPM	
Number of conical bits	48 per 450 mm		60 per 600 mm	
	18" drum		24" drum	
Standard bit type	All purpose		All purpose	
Maximum depth of cut	170 mm	7"	170 mm	7"
Tilt angle range	±8°		±8°	
Side shift travel	750 mm	30"	750 mm	30"

**Skid Steer Loaders
Multi Terrain Loaders
Compact Track Loaders**

WorkTools
● **Cold Planers**

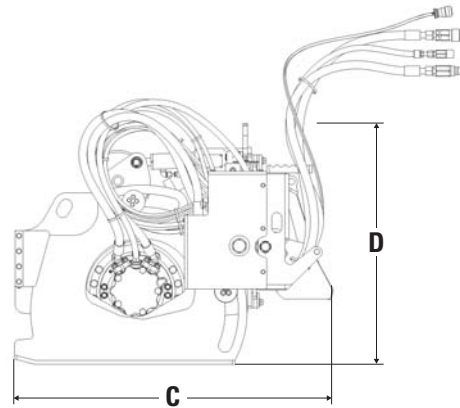
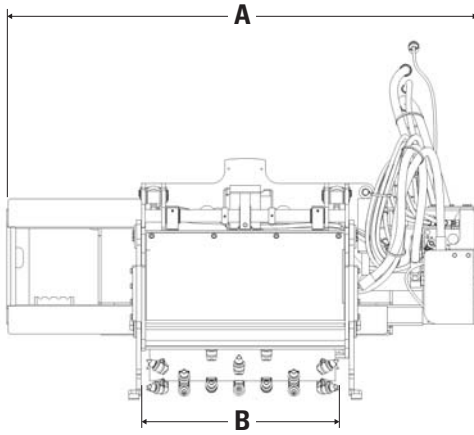

MODEL	PC310B		PC408B		PC412B	
A Overall width	1858 mm	73"	1858 mm	73"	1858 mm	73"
B Maximum drum width	1000 mm	39"	750 mm	30"	1200 mm	47"
Optional drum widths (depths)	—		80 (200) mm	3 (8)"	—	
			152 (200) mm	6 (8)"		
			203 (200) mm	8 (8)"		
			305 (200) mm	12 (8)"		
			350 (200) mm	14 (8)"		
			400 (200) mm	16 (8)"		
			450 (200) mm	18 (8)"		
			610 (178) mm	24 (7)"		
C Length	1140 mm	45"	1270 mm	50"	1140 mm	45"
D Overall height	965 mm	38"	1100 mm	43"	965 mm	38"
Weight	1050 kg	2310 lb	1050 kg	2315 lb	1170 kg	2580 lb
Drive method	Direct drive		Direct drive		Direct drive	
Optimal hydraulic flow	125 L/min	33 gpm	150 L/min	40 gpm	150 L/min	40 gpm
Optimal hydraulic pressure	280 bar	4000 psi	280 bar	4000 psi	280 bar	4000 psi
Drum torque @ max. pressure	3350 N·m	2470 lb-ft	3724 N·m	2746 lb-ft	4108 N·m	3030 lb-ft
Drum speed @ max. flow	166 RPM		143 RPM		161 RPM	
Number of conical bits	78 per 1000 mm		60 per 750 mm		90 per 1200 mm	
	40" drum		30" drum		47" drum	
Standard bit type	All purpose		All purpose		All purpose	
Maximum depth of cut	130 mm	5"	170 mm	7"	130 mm	5"
Tilt angle range	±6.5°		±6.5°		±6.5°	
Side shift travel	650 mm	26"	650 mm	26"	550 mm	22"

Features:

- **Two sizes available:** the 1321 mm (52") working width LT13B and the 1854 mm (73") working width LT18B. Both units efficiently utilize the standard flow auxiliary hydraulic horsepower capabilities of Cat Skid Steer Loaders.
- **Direct drive system** features two in-line motors that transmit power directly from the drive motor shaft to the tiller shaft. Power to both ends of the shaft eliminates torque twist and increased system performance.
- **Adjustable skid shoes** provide a working depth range of 25-152 mm (1"-6").
- **High strength medium carbon alloy steel tines** are hardened for maximum strength, durability and wear life in the toughest soil conditions.
- **Cat XT-3 hose and O-ring face seals** are used throughout for superior leak-free performance.

Market Opportunities

- **Agriculture** — Landscape tillers provide an effective work tool around the farm or orchard to breakup and condition soil prior to planting.
- **Building/General Construction** — Landscape tillers can be used on construction sites to level soil and remove ruts.
- **Landscaping/Landscape Maintenance** — Landscape tillers are ideal for mixing and composting soils for improved seedbeds, soil stabilization and soil preparation prior to landscaping and laying sod.
- **Governmental/Municipalities** — Landscape tillers are ideal for city maintenance departments and parks to recondition, level and stabilize soil after utility work or prior to yearly landscaping.

Landscape tillers are productive work tools for specialized applications. They are often used in conjunction with a bucket, landscape rake and auger.

Machine Compatibility

Landscape Tiller Model	Machine Models
LT13B	216B3, 226B3, 226D, 232D, 236D, 239D, 242D, 246D, 249D, 257D, 259D, 262D, 272D2, 272D2 XHP, 277D, 279D, 287D, 289D, 297D2, 297D2 XHP, 299D2, 299D2 XHP
LT18B	236D, 246D, 249D, 257D, 259D, 262D, 272D2, 272D2 XHP, 277D, 279D, 287D, 289D, 297D2, 297D2 XHP, 299D2, 299D2 XHP

Skid Steer Loaders
Multi Terrain Loaders
Compact Track Loaders

Work Tools
 ● **Landscape Tillers**

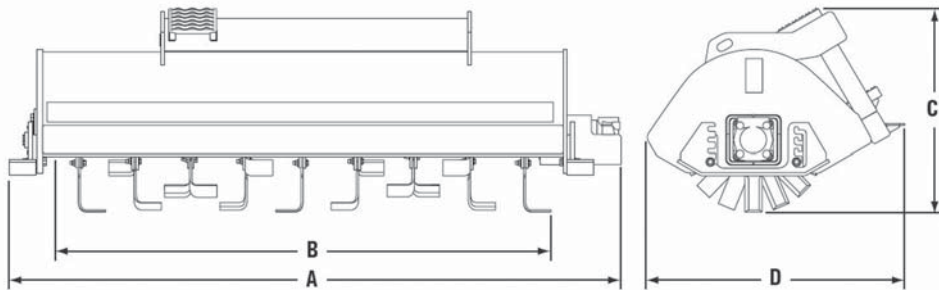

MODEL	LT13B		LT18B	
A Overall width	1788 mm	70.5"	2271 mm	89.5"
B Working width	1321 mm	52"	1847 mm	73"
C Height	755 mm	30"	755 mm	30"
D Length	956 mm	38"	956 mm	38"
Working depth range	25-152 mm	1"-6"	25-152 mm	1"-6"
Weight	340 kg	750 lb	420 kg	926 lb
Drive method	Direct drive		Direct drive	
Number of motors	Two in-line		Two in-line	
Hydraulic flow range	60-86 L/min	16-23 gpm	60-86 L/min	16-23 gpm
Hydraulic pressure	230 bar	3340 psi	230 bar	3340 psi
Motor displacement	629.1 cm ³ /rev	38.4 in³/rev	629.1 cm ³ /rev	38.4 in³/rev
Drum speed @ maximum flow	127 RPM @ 80 L/min	127 RPM @ 21 gpm	127 RPM @ 80 L/min	127 RPM @ 21 gpm
Fasteners	Cat		Cat	
Hydraulic hose	Cat XT-3 ES		Cat XT-3 ES	
Number of tines	24		36	

Features:

- **Two sizes available:** the 1576 mm (62") working width LR15B and the 1883 mm (74") working width LR18B. Both units efficiently utilize the standard flow auxiliary hydraulic horsepower capabilities of Cat Skid Steer Loaders.
- **Chain reduction drive system** features #80H roller chain for strength and durability, a variable speed unidirectional gerotor motor for maximum performance and cartridge relief valve for system protection.
- **Durable #2060H conveyor chain** provides strength, durability and long life in a variety of soil conditions.
- **High strength medium carbon alloy steel teeth** are hardened for maximum strength, durability and wear life in the toughest soil conditions.
- **Quick dumping capability** is accomplished with a poppet check valve. Once the hopper bucket is full, simply reverse flow to actuate the rake head and dump the bucket.
- **Cat XT-3 hose and O-ring face seals** are used throughout for superior leak-free performance.

Market Opportunities

- **Agriculture** — Landscape rakes provide an effective work tool around the farm or nursery to condition, level and remove rock and foreign material from soil prior to planting.
- **Building/General Construction** — Landscape rakes can be used on construction sites to level and remove debris from soil prior to landscaping and seeding.
- **Demolition** — Landscape rakes provide an excellent means to clean up loose material after the demolition work is complete.
- **Landscaping/Landscape Maintenance** — Landscape rakes are ideal for aerating, conditioning, leveling and removing rocks from soil prior to seeding or laying sod. They also are ideal for conditioning and cleaning baseball fields.

Landscape rakes are productive work tools for specialized applications. They are often used in conjunction with a bucket, landscape tiller and auger.

Machine Compatibility

The following are the recommended and approved Cat machine/Landscape Rake combinations for maximum system performance.

Landscape Rake Model	Machine Models*
LR15B	216B3, 226B3, 226D, 232D, 236D, 239D, 242D, 246D, 249D, 257D, 259D, 262D, 272D2, 272D2 XHP, 277D, 279D, 287D, 289D, 297D2, 297D2 XHP, 299D2, 299D2 XHP
LR18B	236D, 246D, 249D, 257D, 259D, 262D, 272D2, 272D2 XHP, 277D, 279D, 287D, 289D, 297D2, 297D2 XHP, 299D2, 299D2 XHP

*Lift restriction! Do not raise lift arm — work tool hinge higher than 1 m (3 ft) above the ground. Tipping can result.

**Skid Steer Loaders
Multi Terrain Loaders
Compact Track Loaders**

WorkTools
● Landscape Rakes

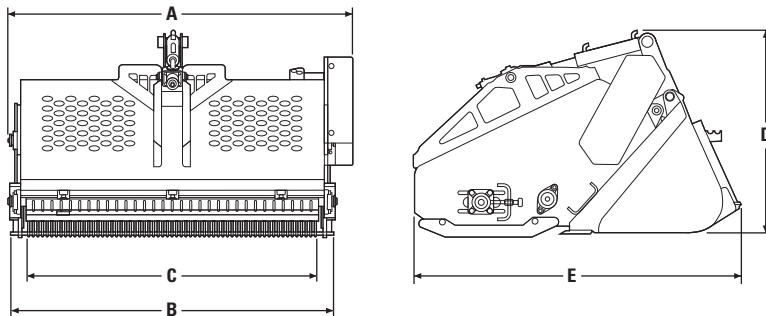

MODEL	LR15B		LR18B	
A Overall width	1683 mm	66"	1990 mm	78"
B Working width	1576 mm	62"	1883 mm	74"
C Raking width	1384 mm	55"	1655 mm	65"
D Height	989 mm	39"	989 mm	39"
E Length	1620 mm	64"	1620 mm	64"
Weight	595 kg	1312 lb	653 kg	1440 lb
Drive method	Chain reduction		Chain reduction	
Drive chain	#80H		#80H	
Conveyor chain	#2060H		#2060H	
Hydraulic flow range	42-86 L/min	11-23 gpm	42-86 L/min	11-23 gpm
Hydraulic pressure range	145-235 bar	2100-3400 psi	145-235 bar	2100-3400 psi
Bucket capacity (struck)*	0.31 m ³	0.4 yd³	0.34 m ³	0.44 yd³
Motor displacement	315 cm ³ /rev	19.2 in³/rev	315 cm ³ /rev	19.2 in³/rev
Driven shaft speed	165 RPM @ 80 L/min	165 RPM @ 21 gpm	165 RPM @ 80 L/min	165 RPM @ 21 gpm
Torque @ 230 bar (3336 psi)	1774 N·m	1310 lb-ft	1774 N·m	1310 lb-ft
Fasteners	Cat		Cat	
Hydraulic hose	Cat XT-3 ES		Cat XT-3 ES	
Number of teeth	372		444	
Rock size	19-152 mm	0.75"-6"	19-152 mm	0.75"-6"

*Rated struck capacities shown as per ISO 7546: 1983 and SAE J742 FEB85.

Features:

- **Dual speed, axial piston hydraulic motor** provides smooth, efficient performance while delivering optimal torque under changing material loads.
- **Rugged mulching head** processes trees up to 200 mm (8 in) diameter for effective forestry clearing applications.
- **Single bolt retention, fixed tooth balanced rotor** provides excellent operating efficiency at high speed. Single bolt retention provides quick tooth replacement.
- **Adjustable push frame** is standard equipment and provides the ability to position trees to allow for optimum cutting and efficiency. In forestry operation it also provides operator cab protection.
- **Pressure gauge** provides operator feedback to adjust speed for maximum productivity in changing material loads. Gauge displays planer performance in real-time conditions and is visible from the cab. Available on XHP models.
- **Heavy-duty bearings** extend work tool life.
- **Hydraulically operated front hood** is standard, allowing trees to be cut when opened and allows dense vegetation to be mulched.
- **Polychain belt drive** provides abrasion resistance, shock load capability and protects against debris blockage.
- **Rear chain guard protection** reduces spread of material.
- **Rigid, robust tempered steel construction** provides fully guarded protection in tough applications.
- **Cat XT-3 ES hose, couplings and O-ring face seals** provide superior, leak-free performance and reliability. All hoses are wrapped with nylon woven cordura sleeving for added operator protection. Hydraulic quick disconnects enable fast tool changes.
- **Quick coupler** with rugged, opposing edge design holds the work tool securely and allows the operator to quickly change from one high performance Cat Work Tool to another.

The **Cat Mulcher** is designed for high-performance cutting, and mulching vegetation and undergrowth from typical forested terrain. The hydraulic mulcher reduces saplings, shrubs and trees into mulched material, making it ideal for environmental maintenance, such as creating fire lanes. Other applications include: reclaiming untilled land, removing foliage from building construction sites, and shredding pruned material and organic waste for biomass production.

Machine Compatibility

Mulcher Model	Machine Models
HM315B*	246D, 262D, 272D2, 272D2 XHP, 277D, 279D, 287D, 289D, 297D2, 297D2 XHP, 299D2, 299D2 XHP
HM415B	272D2 XHP, 297D2 XHP, 299D2 XHP

*Requires high flow XPS option on machine. Operates in high flow XPS on XHP machines.
Debris Barrier package recommended.

**Skid Steer Loaders
Multi Terrain Loaders
Compact Track Loaders**

WorkTools
● **Mulchers**

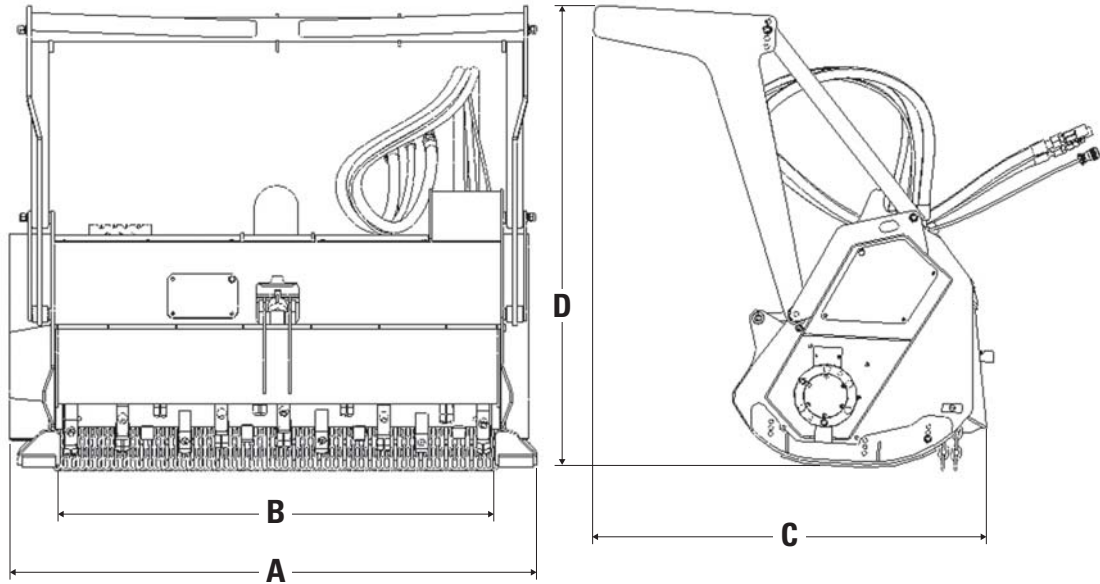

MODEL	HM315B		HM415B	
A Overall width	1840 mm	72"	1840 mm	72"
B Working width	1465 mm	58"	1465 mm	58"
C Length	1470 mm	58"	1470 mm	58"
D Overall height	1610 mm	63"	1610 mm	63"
Weight	1165 kg	2564 lb	1165 kg	2564 lb
Drive method	Polychain belt		Polychain belt	
Hydraulic motor type	Dual speed axial piston		Dual speed axial piston	
Hydraulic flow range	120-137 L/min	31.5-36 gpm	137-155 L/min	36-41 gpm
Hydraulic pressure range	195-350 bar	2828-5075 psi	195-350 bar	2828-5075 psi
Drum speed range	2100-2400 RPM		1900-2200 RPM	
Number of teeth	34		34	
Maximum diameter of material to be cut	200 mm	8"	200 mm	8"

Features:

- **A heavy-duty frame, pivot plate and attachment plate** are featured for reliable operation in rugged terrain and abusive soil conditions.
- **Pure carbide, blunt shaped teeth** create a dimpled sub-surface to ensure the best possible seedbed sub-base fracture pattern.
- **Two-position winged endplates** allow close raking to side walks or foundations. They can remain parallel, even during angling, for smoother plowing.
- **Convenient, heavy-duty, deep skid-resistant step** and a generous cab allow for easy operator entry and exit.
- **Dual independently adjustable gauge wheels** allow for skim passes for over-seeding or adjust to cut drainage grades.
- **Cat XT-3 ES hose, couplings and O-ring face seals** provide superior, leak-free performance and reliability. All hoses are wrapped with nylon woven cordura sleeving for added operator protection. Hydraulic quick disconnects enable fast tool changes.
- **Quick coupler** with rugged, opposing edge design holds the work tool securely and allows the operator to quickly change from one high performance Cat Work Tool to another.

Cat Power Box Rakes are ideal for clearing and preparing soil in general construction trench restoration, golf course construction and athletic field maintenance. They offer the versatility to de-thatch, remove old lawns and weeds, grade, level, rake, remove debris and prepare seedbeds with one work tool. Their angling ability allows the operator to windrow collected debris for easy pickup and removal. The consistent milling action creates an ideal seedbed for great germination results, laying the groundwork for a perfect lawn. Wet, dry, weedy, hard and rocky soil can be dried, flattened, pulverized and conditioned for seed in one step.

Machine Compatibility

Power Box Rake Model	Machine Models
PR172	216B3, 226B3, 226D, 232D, 236D, 239D, 242D, 246D, 249D, 257D, 259D, 262D, 272D2, 272D2 XHP, 277D, 279D, 287D, 289D, 297D2, 297D2 XHP, 299D2, 299D2 XHP
PR184	216B3, 226B3, 226D, 232D, 236D, 239D, 242D, 246D, 249D, 257D, 259D, 262D, 272D2, 272D2 XHP, 277D, 279D, 287D, 289D, 297D2, 297D2 XHP, 299D2, 299D2 XHP
PR190	216B3, 226B3, 226D, 232D, 236D, 239D, 242D, 246D, 249D, 257D, 259D, 262D, 272D2, 272D2 XHP, 277D, 279D, 287D, 289D, 297D2, 297D2 XHP, 299D2, 299D2 XHP

**Skid Steer Loaders
Multi Terrain Loaders
Compact Track Loaders**

WorkTools
● **Power Box Rakes**

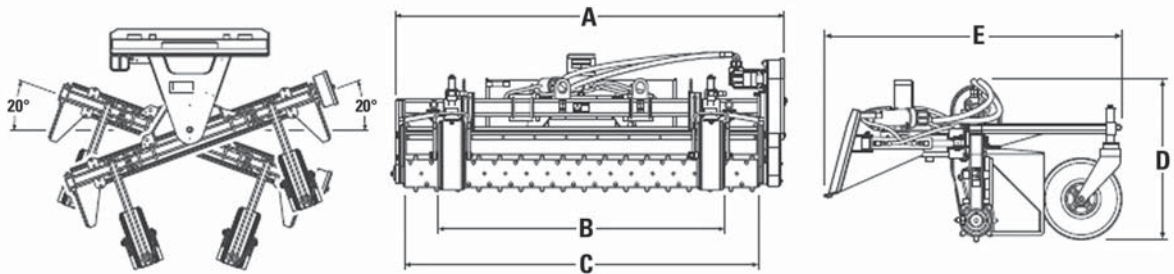

MODEL	PR172		PR184		PR190	
A Overall width	2057 mm	81"	2362 mm	93"	2515 mm	99"
B Width over tires	1386 mm	55"	1732 mm	68"	1845 mm	73"
C Roller width	1829 mm	72"	2134 mm	84"	2286 mm	90"
D Overall height	847 mm	34"	847 mm	34"	953 mm	38"
E Overall length	1626 mm	64"	1626 mm	64"	1626 mm	64"
Raking width at maximum angle	1727 mm	68"	2007 mm	79"	2159 mm	85"
Unit weight (Manual)	408 kg	900 lb	465 kg	1026 lb	588 kg	1296 lb
Unit weight (Hydraulic)	420 kg	925 lb	476 kg	1050 lb	599 kg	1320 lb
Maximum working angle	20°		20°		20°	
Optimal hydraulic flow	49-86 L/min	13-23 gpm	57-86 L/min	15-23 gpm	57-86 L/min	15-23 gpm
Optimal hydraulic pressure	230 bar	3340 psi	230 bar	3340 psi	230 bar	3340 psi

Features:

- **Direct drive system** features a variable speed, bidirectional, gerotor style motor that delivers optimal chain speed, chain pull and torque for maximum trenching performance in a broad range of soil types.
- **Durable double standard anti-backflex chain** is standard for strength, durability and long life in all soil types.
- **Standard boom lengths** for all-purpose performance. Replaceable weld-on wear strips extend boom life.
- **Hardfaced, tungsten carbide steel cupped teeth** are standard for long life in many soil conditions. Teeth are spaced for optimum digging performance in most soil.
- **Hydraulic or manual side-shift on the T6B and T9B** provides close trenching flexibility near structures or obstructions.
- **Hydraulic side-shift on the T15B** is controlled from the operator's compartment using the standard flow auxiliary hydraulic circuit selector control.
- **Optional cutting widths and crumber bars** are available for wider trenching requirements and loose material removal.
- **Cat XT-3 hose and O-ring face seals** are used throughout for superior leak-free performance.

Market Opportunities

- **Agriculture** — Trenchers provide an effective work tool around the farm or nursery to cut trenches for water lines, electrical cables and other utilities.
- **Building/General Construction** — Trenchers are often used on construction sites to cut trenches for plumbing, electrical, telephone and cable television lines.
- **Landscaping/Landscape Maintenance** — Trenchers are popular landscaping work tools when installing irrigation and water sprinkler systems. They can also be used to remove roots that grow too close to buildings or cart paths. Landscapers, golf course maintenance departments and irrigation contractors are prime users.
- **Specialty Trades/Utilities** — Trenchers are excellent work tools for specialty trades and utility contractors that need to bury water and gas pipe, conduit, electrical, telephone and cable television lines.

Trenchers are productive work tools for specialized applications. They are often used in conjunction with a bucket and auger.

Machine Compatibility

Trencher Model	Machine Models
T6B	216B3, 226B3, 226D, 232D, 236D, 239D, 242D, 246D, 249D, 257D, 259D, 262D, 272D2, 272D2 XHP, 277D, 279D, 287D, 289D, 297D2, 297D2 XHP, 299D2, 299D2 XHP
T9B	216B3, 226B3, 226D, 232D, 236D, 239D, 242D, 246D, 249D, 257D, 259D, 262D, 272D2, 272D2 XHP, 277D, 279D, 287D, 289D, 297D2, 297D2 XHP, 299D2, 299D2 XHP
T15B*	226B3, 226D, 232D, 239D, 242D, 246D, 249D, 257D, 259D, 262D, 272D2, 272D2 XHP, 277D, 279D, 287D, 289D, 297D2, 297D2 XHP, 299D2, 299D2 XHP

*Requires high flow or high flow XPS option on machine.

T6B/T9B Trencher

Theoretical Drive Shaft Torque			
Pressure		Torque	
bar	psi	N-m	lb-ft
145	2100	848	625
152	2200	889	655
158	2300	924	681
166	2400	971	716
172	2500	1006	741
179	2600	1047	772
186	2700	1088	802
193	2800	1129	832
200	2900	1170	863
207	3000	1211	893
214	3100	1252	923
220	3200	1287	949
227	3300	1328	979

T15B Trencher

Theoretical Drive Shaft Torque			
Pressure		Torque	
bar	psi	N-m	lb-ft
207	3000	1916	1413
214	3100	1981	1461
220	3200	2036	1501
227	3300	2101	1549
235	3400	2175	1604
242	3500	2240	1652
248	3600	2295	1692
255	3700	2360	1740
262	3800	2425	1788
269	3900	2490	1836
276	4000	2555	1884
283	4100	2619	1931
290	4200	2684	1979
297	4300	2749	2027
304	4400	2814	2075
311	4500	2878	2122

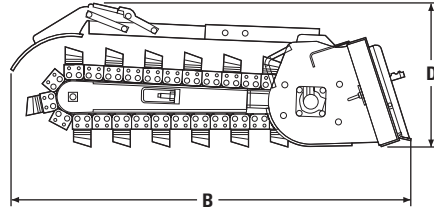
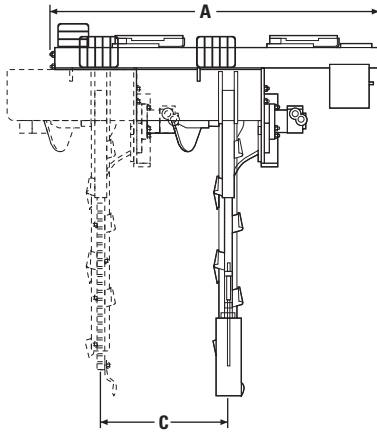

MODEL	T6B		T9B		T15B	
A Overall width	1426 mm	56"	1901 mm	74.8"	1901 mm	74.8"
B Overall length	2337 mm	92"	2705 mm	106.5"	3010 mm	118.5"
C Side shift travel (center to right)	419 mm	16.5"	559 mm	22"	559 mm	22"
D Height	786 mm	30.9"	786 mm	30.9"	786 mm	30.9"
Max. auger clearance	534 mm	21"	534 mm	21"	534 mm	21"
Spoil auger diameter	457 mm	18"	457 mm	18"	457 mm	18"
Standard boom length	914 mm	36"	1219 mm	48"	1524 mm	60"
Weight	397 kg*	875 lb*	551 kg**	1215 lb**	601 kg***	1325 lb***
Optimal hydraulic flow range	42-86 L/min	11-23 gpm	42-86 L/min	11-23 gpm	95-152 L/min	25-40 gpm
Optimal hydraulic pressure range	145-235 bar	2100-3400 psi	145-235 bar	2100-3400 psi	207-310 bar	3000-4500 psi
Motor displacement	393.9 cm ³	24.0 in³	393.9 cm ³	24.0 in³	629.1 cm ³	38.4 in³
Theoretical drive shaft torque	1447 N·m	1068 lb-ft	1447 N·m	1068 lb-ft	2905 N·m	2144 lb-ft
Chain pull @ max. pressure ¹	1207 kg	2661 lb	1207 kg	2661 lb	2424 kg	5344 lb
Chain speed @ max. flow ²	155 m/min	508.5 ft/min	155 m/min	508.5 ft/min	158 m/min	518.3 ft/min
Drive shaft speed @ max. flow	203 RPM @		203 RPM @		207 RPM @	
	80 L/min	21 gpm	80 L/min	21 gpm	129 L/min	34 gpm
Optional cutting widths	152, 203,	(6", 8",	152, 203,	(6", 8",	152, 203,	(6", 8",
	254, 305 mm	10", 12")	254, 305 mm	10", 12")	254, 305 mm	10", 12")

*T6B bare configuration, no chain.

**T9B equipped with 1219 mm (48") boom, hydraulic side shift control, double standard anti-backflex chain, 203 mm (8") cutting width, 50/50 carbide/cup chain.

***T15B equipped with 1524 mm (60") boom, double standard anti-backflex chain, 203 mm (8") cutting width, 50/50 carbide/cup chain.

¹Max. Pressure: T6B, T9B — 230 bar (3335 psi), T15B — 290 bar (4206 psi).

²Max. Flow: T6B, T9B — 80 L/min (21 gpm), T15B — 130 L/min (34 gpm).

Features:

- **Caterpillar exclusive vibratory pod design** delivers desired balance between frequency and amplitude to provide a superior matte finish. Pod-style weight housings are factory sealed for longer bearing life and easy serviceability.
- **Higher compaction forces** provide twice the compaction force of the original design requiring fewer passes for greater productivity.
- **Replaceable rubber mounts** isolate vibration and enhance vibratory capabilities.
- **Durable high-strength steel drums** are roll formed and finish welded for a smoother surface and longer life.
- **Pivoting interface** allows the drum to oscillate $\pm 15^\circ$ and follow the contour of the ground.
- **Cat XT-3 hose and O-ring face seals** are used throughout for superior leak-free performance.

Market Opportunities

- **Building/General Construction** — Vibratory compactors can be used on construction sites to level and compact soil around building foundations after backfilling.
- **Governmental/Municipalities (Street and Road Maintenance)** — Vibratory compactors are useful work tools for compacting soil and crushed rock prior to paving or pouring concrete. They are also useful for compacting small areas of asphalt (pothole repair).
- **Landscaping/Landscape Maintenance** — Vibratory compactors are used by landscaping contractors after installing irrigation and water sprinkler systems. Golf course maintenance departments will often use this product to compact greens and fairways.
- **Paving** — Vibratory compactors are used by paving contractors for smaller paving jobs (compacting soil and crushed stone), compacting hot patch (pot hole repair) or compacting material in tight areas where a dedicated roller can't maneuver.
- **Specialty Trades/Utilities** — Vibratory compactors are ideal for compacting back-filled soil after trenching and backhoe work.

Vibratory compactors are productive work tools for specialized applications. They are often used in conjunction with a bucket, cold planer and trencher.

Machine Compatibility

Vibratory Compactor Model	Machine Models*
CV16B	216B3, 226B3, 226D, 232D, 236D, 239D, 242D, 246D, 249D, 257D, 259D, 262D, 272D2, 272D2 XHP, 277D, 279D, 287D, 289D, 297D2, 297D2 XHP, 299D2, 299D2 XHP
CV18B	246D, 262D, 272D2, 272D2 XHP, 277D, 279D, 287D, 289D, 297D2, 297D2 XHP, 299D2, 299D2 XHP

*Lift restriction! Do not raise lift arm — work tool coupler interface higher than 1 m (3 ft) above the ground. Tipping can result.

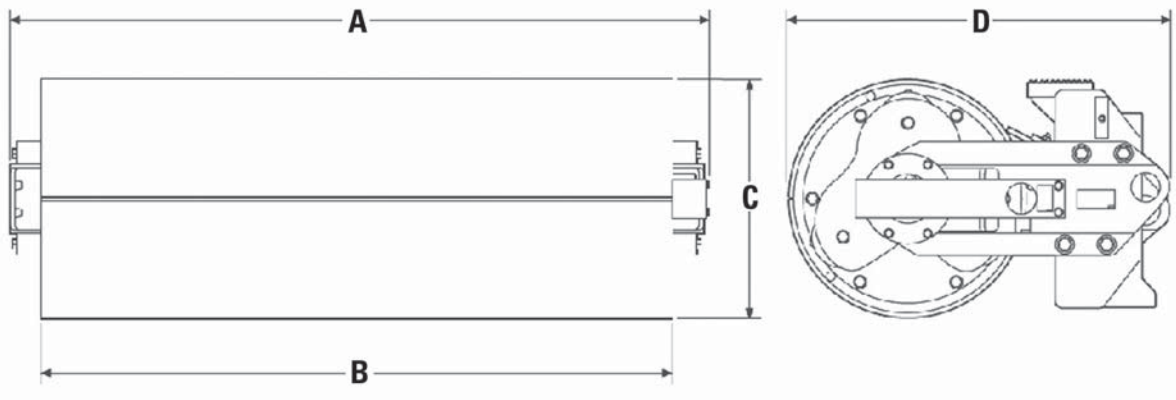

MODEL	CV16B		CV18B	
A Overall width	1854 mm	73"	2032 mm	80"
B Drum width	1676 mm	66"	1854 mm	73"
C Overall height	634 mm	25"	634 mm	25"
D Overall length	1009 mm	40"	1009 mm	40"
Drum diameter	634 mm	25"	634 mm	25"
Weight	936 kg	2063 lb	970 kg	2138 lb
Drive method	Direct drive		Direct drive	
Number of motors	1		1	
Motor size	28.2 cm ³	1.72 in ³	28.2 cm ³	1.72 in ³
Hydraulic flow range	42-86 L/min	11-23 gpm	42-86 L/min	11-23 gpm
Hydraulic pressure range	145-235 bar	2100-3400 psi	145-235 bar	2100-3400 psi
Drum oscillation range	±15°		±15°	
Drum frequency @ maximum flow	2946 vibrations/min		2946 vibrations/min	
Dynamic force	5399 kg	11,903 lb	5399 kg	11,903 lb
Amplitude	1.16 mm	0.046"	1.09 mm	0.043"

Features:

- **Pickup Brooms** sweep and deposit material into an integrated hopper bucket for easy removal and dumping. Bidirectional capabilities of the bristles allow Pickup and Utility Brooms to sweep in forward or reverse machine travel. Optimum sweeping style is in forward travel, resulting in over-the-brush pickup. Certain conditions require a dust pan style of sweeping, done in reverse travel.
- **Utility Brooms** sweep and collect light debris on smooth surfaces in forward or reverse travel. They can be adjusted for greater bristle down-force in tough applications such as sweeping course material out of a cold planer cut.
- **Angle Brooms** use a single variable speed, unidirectional gerotor style hydraulic motor, contained in a protective housing. They use a windrowing action to move loose debris ahead and to the side of the surface being swept. They can be oriented straight or angled up to 30° left or right of center in forward travel.
- **Direct drive motors** provide maximum performance and durability. Pickup and Utility Brooms use a single variable speed, bidirectional gerotor style hydraulic motor, contained in a special housing that is adjustable to compensate for bristle wear. Angle brooms use a single variable speed unidirectional gerotor style hydraulic motor contained in a protective housing.
- **Polypropylene/wire convoluted brushes** provide optimum results for sweeping. Optional all-polypropylene and all-steel wire convoluted brushes are available for specialty applications. Convoluted brush sections are available in half-kits for easy maintenance and quick replacement.
- **Drop core design** allows for quick bristle replacement without removing hydraulic hoses.
- **Quick coupler** with rugged, opposing edge design holds the work tool securely and allows the operator to quickly change from one high performance Cat Work Tool to another.

Market Opportunities

- **Building/General Construction** — Brooms are often found on construction sites once the construction is complete to remove and collect dirt, rock and other construction debris from driveways, sidewalks and streets.

- **Demolition** — Brooms are ideal for collecting loose dirt and debris from demolition sites.
- **Governmental/Municipalities (Street and Road Maintenance)** — Brooms are useful work tools for cleaning city streets, sidewalks and parking areas. Airport maintenance is another popular application.
- **Industrial/Recycling** — Pickup brooms are excellent for cleaning factory floors or industrial pavements.
- **Landscaping/Landscape Maintenance** — Brooms are used by landscaping contractors to clean paved surfaces after the landscaping is complete. Golf course maintenance departments will often use this product to clean cart paths, parking lots and even turf.
- **Paving** — Pickup brooms are often used by paving contractors to sweep and collect milled asphalt and concrete. Angle brooms are used to clean milled surfaces.
- **Specialty Trades/Utilities** — Brooms are often utilized by specialty trades and utility contractors to clean up after trenching and backhoe work.

Pickup brooms are productive work tools for specialized applications. They are often used in conjunction with a bucket, cold planer and trencher.

Machine Compatibility

Broom Model	Machine Models
BP115C	216B3, 226B3, 226D, 232D, 236D, 239D, 242D, 246D, 249D, 257D, 259D, 262D, 272D2, 272D2 XHP, 277D, 279D, 287D, 289D, 297D2, 297D2 XHP, 299D2, 299D2 XHP
BP118C	236D, 246D, 249D, 257D, 259D, 262D, 272D2, 272D2 XHP, 277D, 279D, 287D, 289D, 297D2, 297D2 XHP, 299D2, 299D2 XHP
BA118C	216B3, 226B3, 226D, 232D, 236D, 239D, 242D, 246D, 249D, 257D, 259D, 262D, 272D2, 272D2 XHP, 277D, 279D, 287D, 289D, 297D2, 297D2 XHP, 299D2, 299D2 XHP
BU115	216B3, 226B3, 226D, 232D, 236D, 239D, 242D, 246D, 249D, 257D, 259D, 262D, 272D2, 272D2 XHP, 277D, 279D, 287D, 289D, 297D2, 297D2 XHP, 299D2, 299D2 XHP
BU118	236D, 242D, 246D, 257D, 259D, 262D, 272D2, 272D2 XHP, 277D, 279D, 287D, 289D, 297D2, 297D2 XHP, 299D2, 299D2 XHP

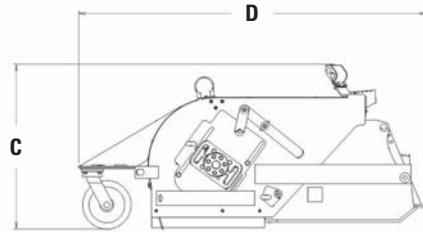
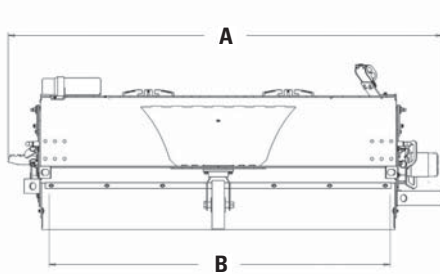

Pickup Brooms

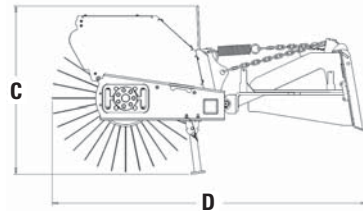
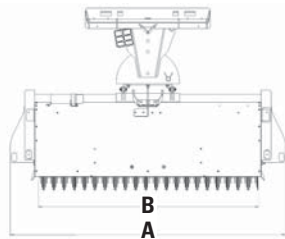
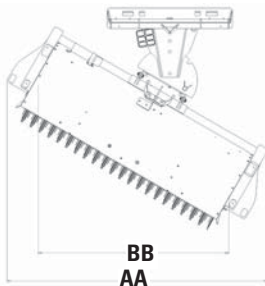

Angle Brooms

MODEL	BP115C Pickup Broom		BP118C Pickup Broom		BA118C Angle Broom	
A Overall width	1990 mm	78"	2295 mm	90"	2637 mm	104"
AA Overall width angled (±30°)	N/A		N/A		2508 mm	99"
B Sweeping width	1524 mm	60"	1829 mm	72"	2119 mm	83"
BB Sweeping width angled (±30°)	N/A		N/A		1849 mm	73"
C Height	872 mm	34"	872 mm	34"	918 mm	36"
D Length without gutter brush	1837 mm	72"	1837 mm	72"	1741 mm	69"
Weight without gutter brush	526 kg	1160 lb	570 kg	1258 lb	401 kg	885 lb
Drive method	Direct drive		Direct drive		Direct drive	
Motor displacement	405 cm ³ /rev	25 in ³ /rev	405 cm ³ /rev	25 in ³ /rev	405 cm ³ /rev	25 in ³ /rev
Optimal hydraulic flow range	42-86 L/min	11-23 gpm	42-86 L/min	11-23 gpm	42-86 L/min	11-23 gpm
Optimal hydraulic pressure range	145-235 bar	2100-3400 psi	145-235 bar	2100-3400 psi	145-235 bar	2100-3400 psi
Brush speed (shaft) @ maximum flow*	199 RPM		199 RPM		199 RPM	
Hopper capacity (struck)**	0.41 m ³	0.54 yd ³	0.49 m ³	0.64 yd ³	N/A	
	0.41 m ³	14.6 ft ³	0.49 m ³	17.4 ft ³		
Fasteners	Cat		Cat		Cat	
Hydraulic hose	Cat XT-3 ES		Cat XT-3 ES		Cat XT-3 ES	
Brush diameter	660 mm	26"	660 mm	26"	815 mm	32"
Brush head retention	Dual chain/ loader arm bracket		Dual chain/ loader arm bracket		N/A	
Brush material (standard)	Replaceable polypropylene/ steel wire sections		Replaceable polypropylene/ steel wire sections		Replaceable polypropylene/ steel wire sections	

*Gutter brush receives 5 gpm maximum flow when installed.

**Rated struck capacities shown as per ISO 7546:1983 and SAE J742 FEB85.

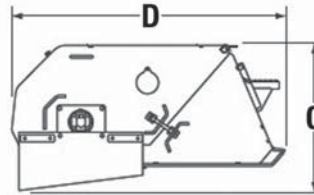
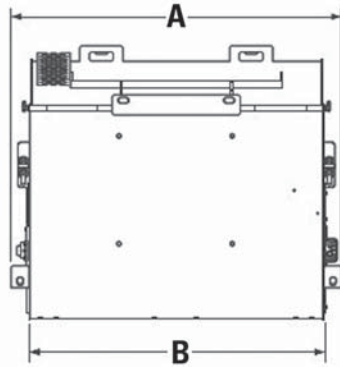

Utility Brooms

MODEL	BU115 Utility Broom		BU118 Utility Broom	
A Overall width	1810 mm	71"	2115 mm	83"
B Sweeping width	1510 mm	59"	1865 mm	73"
C Height	793 mm	31"	793 mm	31"
D Length	1490 mm	59"	1490 mm	59"
Weight	422 kg	930 lb	481 kg	1060 lb
Drive method	Direct drive		Direct drive	
Number of motors	1		1	
Motor displacement	393 cm ³ /rev	24 in³/rev	393 cm ³ /rev	24 in³/rev
Hydraulic flow range	30-86 L/min	8-23 gpm	30-86 L/min	8-23 gpm
Hydraulic pressure range	145-235 bar	2100-3400 psi	145-235 bar	2100-3400 psi
Rated brush speed @ maximum flow	220 RPM		220 RPM	
Hopper capacity*	0.42 m ³	0.55 yd³	0.49 m ³	0.64 yd³
Fasteners	Cat		Cat	
Hydraulic hose	Cat XT-3 ES		Cat XT-3 ES	
Brush diameter	660 mm	26"	660 mm	26"
Brush material (standard)	Replaceable polypropylene sections		Replaceable polypropylene sections	
Brush material (optional)	Replaceable steel wire sections		Replaceable steel wire sections	

*Rated struck capacities shown as per ISO 7546:1983 and SAE J742 FEB85.

Features:

- **Two direct drive models, the standard flow SG16B and the high flow SG18B** feature a variable speed, unidirectional motor that is matched to the Cat Skid Steer Loader’s auxiliary hydraulic horsepower capabilities. Provides high torque for efficient grinding performance.
- **Heavy-duty 547 mm (21.5") cutting wheel and 32 bolt-on carbide teeth** provide maximum durability and cutting efficiency.
- **Heavy-duty, dual height, pivoting stand feet** provide a stable platform when grinding.
- **Standard hydraulic cutting wheel swing** (full 70 degrees) and extension [280 mm (11 in) max.].
- **Hydraulic depth control on SG18B, depth control on SG16B** is manually adjustable using a 3-position depth control bar.
- **Extension slider rods** are chrome plated for long life.
- **Cat XT-3 and medium pressure hose, couplings and O-Rings.**

Market Opportunities

- **Landscaping/Landscaping Maintenance** — Stump grinders are ideal for economically removing tree stumps in residential, commercial and agricultural settings.
- **Rental** — Stump grinders are a high opportunity rental work tool for lawn care and for clean up after natural disasters such as tornadoes and hurricanes where many trees are damaged.

Stump grinders are productive work tools for specialized applications. Maneuverability and compact size compared to tow behind stump grinders lend it be to very popular in lawn care and golf course maintenance.

Machine Compatibility

Stump Grinder Model	Machine Models
SG16B	216B3, 226B3, 226D, 232D, 236D, 239D, 242D, 246D, 249D, 257D, 259D, 262D, 272D2, 272D2 XHP, 277D, 279D, 287D, 289D, 297D2, 297D2 XHP, 299D2, 299D2 XHP
SG18B*	226B3, 226D, 232D, 236D, 239D, 242D, 246D, 249D, 257D, 259D, 262D, 272D2, 272D2 XHP, 277D, 279D, 287D, 289D, 297D2, 297D2 XHP, 299D2, 299D2 XHP

*Requires high flow or high flow XPS option on machine.

Skid Steer Loaders
Multi Terrain Loaders
Compact Track Loaders

WorkTools
● Stump Grinders

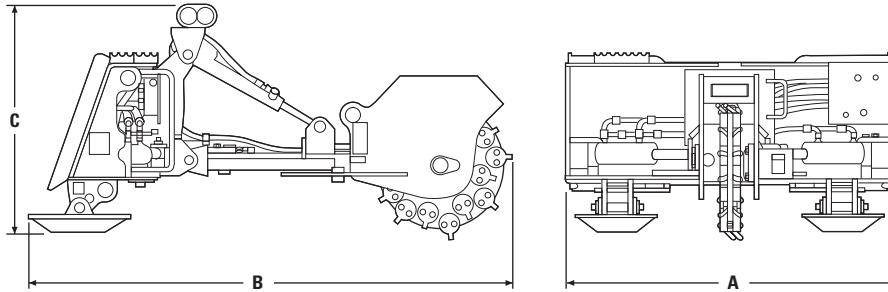

MODEL	SG16B		SG18B	
A Overall width	1175 mm	46"	1175 mm	46"
B Overall length	1737 mm	69"	1737 mm	69"
C Overall height	730 mm	30"	813 mm	32"
Unit weight	379 kg	775 lb	400 kg	840 lb
Drive method	Gerotor Motor – Direct		Gerotor Motor – Direct	
Optimal hydraulic flow	42-86 L/min	11-23 gpm	95-125 L/min	25-33 gpm
Optimal hydraulic pressure	145-235 bar	2100-3400 psi	207-310 bar	3000-4500 psi
Effective displacement	80 cm ³	4.9 in³	100 cm ³	6.2 in³
Drive shaft torque @ maximum pressure	295 N·m @ 230 bar	218 lb-ft @ 3336 psi	469 N·m @ 290 bar	346 lb-ft @ 4206 psi
Cutting head speed (drive shaft) @ maximum flow	993 RPM @ 80 L/min	993 RPM @ 21 gpm	1280 RPM @ 130 L/min	1280 RPM @ 34 gpm
Cutting wheel width (with teeth)	83 mm	3.3"	83 mm	3.3"
Cutting wheel diameter (with teeth)	547 mm	21.5"	547 mm	21.5"
Cutting width (full swing range)	1524 mm	60"	1524 mm	60"
Cutting head swing range		70°		70°
Cutting height (above ground)	470 mm	18.5"	470 mm	18.5"
Cutting height (below ground)	521 mm	20.5"	521 mm	20.5"
Cutting head extension	280 mm	11"	280 mm	11"
Fasteners	Cat		Cat	
Hydraulic hose	XT-3 ES, medium pressure		XT-6 ES, medium pressure	
Ground Engaging Tools (GET)	12.7 mm (1/2") square bolt-on carbide teeth		12.7 mm (1/2") square bolt-on carbide teeth	
Number of carbide teeth per cutting wheel	32		32	

SG16B Stump Grinder

Theoretical Drive Shaft Torque			
Pressure		Torque	
bar	psi	N-m	lb-ft
145	2100	186	137
152	2200	194	143
158	2300	204	150
166	2400	212	156
172	2500	222	163
179	2600	230	169
186	2700	239	176
193	2800	248	182
200	2900	257	189
207	3000	265	195
214	3100	275	202
220	3200	283	208
227	3300	292	215

SG18B Stump Grinder

Theoretical Drive Shaft Torque			
Pressure		Torque	
bar	psi	N-m	lb-ft
207	3000	336	247
214	3100	347	255
221	3200	358	263
227	3300	370	272
234	3400	381	280
241	3500	392	288
248	3600	403	296
255	3700	413	304
262	3800	426	313
269	3900	437	321
276	4000	447	329
282	4100	458	337
289	4200	471	346
296	4300	481	354
303	4400	492	362
310	4500	503	370

SG16B Stump Grinder

Theoretical Cutting Head Speed (Drive Shaft)		
Flow		Cutting Head Speed
L/min	gpm	RPM
42	11	519
45	12	566
49	13	613
53	14	660
57	15	707
61	16	754
64	17	801
68	18	849
72	19	896
76	20	943
80	21	990
83	22	1037

SG18B Stump Grinder

Theoretical Cutting Head Speed (Drive Shaft)		
Flow		Cutting Head Speed
L/min	gpm	RPM
95	25	931
99	26	969
102	27	1006
106	28	1043
110	29	1080
114	30	1118
118	31	1155
122	32	1192
125	33	1230

**Skid Steer Loaders
Multi Terrain Loaders
Compact Track Loaders**

**WorkTools
● Angle Blades**

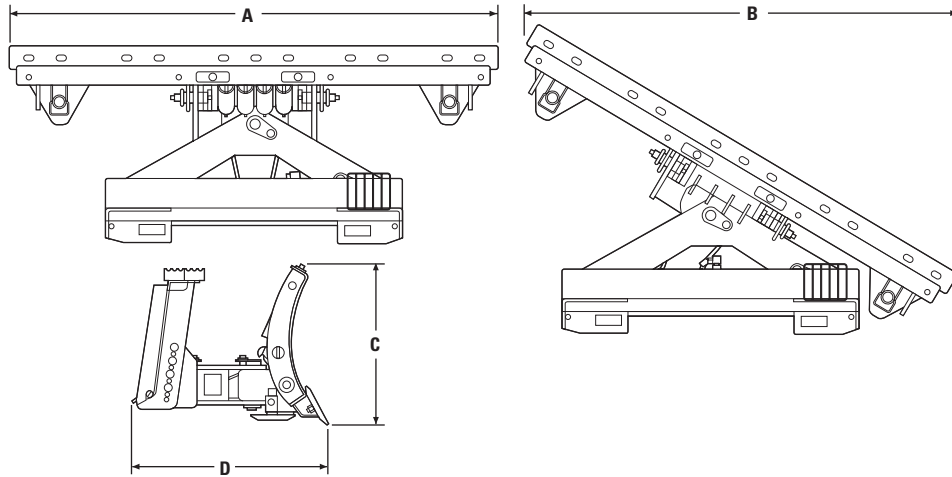

A Overall width (straight)*	1829 mm	72"	2134 mm	84"
B Working width, fully angled	1685 mm	66"	1949 mm	78"
C Height	614 mm	24"	614 mm	24"
D Length	753 mm	30"	753 mm	30"
Weight	313 kg	690 lb	331 kg	730 lb
Adjustable cutting depth (three positions — 25.4 mm (1") increments)	0, 25 and 51 mm	0", 1" and 2"	0, 25 and 51 mm	0", 1" and 2"
Maximum blade angle — (right or left of center)		30°		30°
Maximum blade trip angle		60°		60°

*Measured from moldboard edges; overall width is approximately 50 mm (2") wider with bolt-on edge.

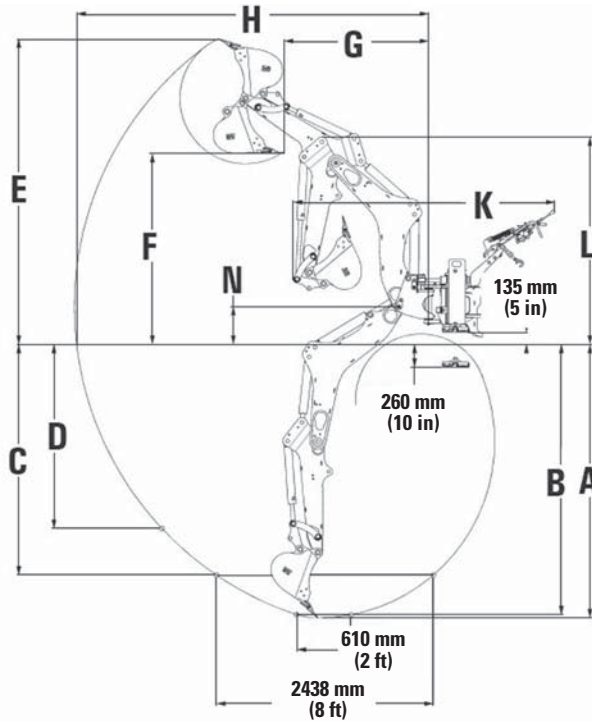

MODEL	BH150		BH160	
Operational Specifications				
A Digging depth maximum	3074 mm	121"	3074 mm	121"
B Digging depth 0.61 m (2') flat bottom	3040 mm	120"	3040 mm	120"
C Digging depth 2.44 m (8') flat bottom	2593 mm	102"	2593 mm	102"
D Straight wall digging depth	2064 mm	81"	2064 mm	81"
E Overall operating height	3442 mm	136"	3442 mm	136"
F Loading height	2147 mm	85"	2147 mm	85"
G Loading reach	1628 mm	64"	1628 mm	64"
H Reach from swing pivot	3955 mm	156"	3955 mm	156"
K Overall length	2776 mm	109"	2936 mm	116"
Side shift travel	742 mm	29"	894 mm	35"
Swing arc	180°		180°	
Bucket rotation	192°		192°	
Bucket breakout force	3241 kg	7146 lb	3241 kg	7146 lb
Stick breakout force	1560 kg	3439 lb	1560 kg	3439 lb
Transport Dimensions				
L Transport height	2336 mm	92"	2336 mm	92"
N Boom pivot height	425 mm	17"	425 mm	17"
Ground clearance	85.7 mm	3.4"	85.7 mm	3.4"
Operating weight	1023 kg	2256 lb	1047 kg	2309 lb

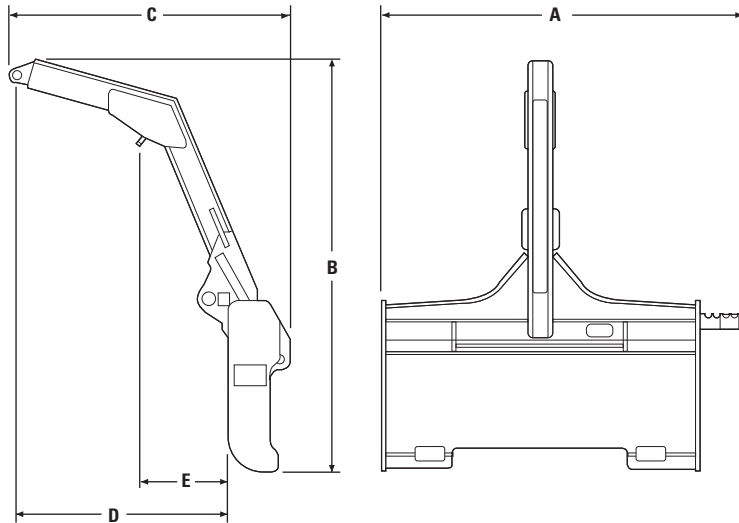

A Width with side step	1309 mm	52"
B Height	1473 mm	58"
C Length	1016 mm	40"
D Load length (end point)	768 mm	30"
E Load length (mid point)	311 mm	12"
Rated structural capacity*	907 kg	2000 lb
Maximum reach (horizontal)**	2134 mm	84"
Weight	127 kg	280 lb

*Rated structural capacity is the maximum load that can be carried by the work tool and does not imply that the specific host machine has the tipping capacity to lift the load. Refer to the Cat Skid Steer Loader and Multi Terrain Loader Operation and Maintenance Manual (OMM) for Cat Skid Steer Loader and Multi Terrain Loader rated operating capacity with Material Handling Arm.

**Maximum horizontal reach is measured from the front tire with the loader arms approximately 1.5 m (5') off the ground and work tool tilted forward approximately 68 degrees at the end point.

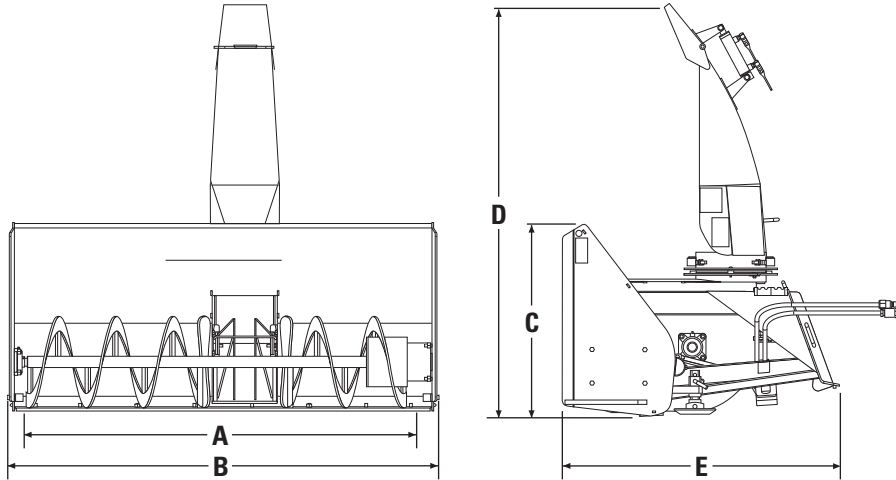

MODEL	SR117		SR118		SR121	
A Intake width	1702 mm	67"	1854 mm	73"	2159 mm	85"
B Overall width	1765 mm	69.5"	1918 mm	75.5"	2223 mm	87.5"
C Cutting height	610 mm	24"	826 mm	33"	883 mm	35"
D Overall height	1797 mm	71"	1797 mm	71"	1797 mm	71"
E Overall length	1148 mm	45.2"	1209 mm	47.6"	1440 mm	56.7"
Weight	419 kg	924 lb	474 kg	1045 lb	591 kg	1303 lb
Maximum throw distance*	9.1 m	30'0"	12.2 m	40'0"	12.2 m	40'0"
Auger diameter	305 mm	12"	406 mm	16"	457 mm	18"
Impeller/fan diameter	517 mm	20"	517 mm	20"	679 mm	27"
Chute rotation	180°		180°		180°	
Optimal hydraulic flow	53-75 L/min	14-20 gpm	68-83 L/min	18-22 gpm	68-87 L/min	18-23 gpm

MODEL	SR318		SR321	
A Intake width	1854 mm	73"	2159 mm	85"
B Overall width	1918 mm	75.5"	2223 mm	87.5"
C Cutting height	826 mm	33"	883 mm	35"
D Overall height	1957 mm	77"	1957 mm	77"
E Overall length	1209 mm	47.6"	1440 mm	56.7"
Weight	475 kg	1047 lb	592 kg	1305 lb
Maximum throw distance*	13.7 m	45'0"	13.7 m	45'0"
Auger diameter	406 mm	16"	457 mm	18"
Impeller/fan diameter	517 mm	20"	679 mm	27"
Chute rotation	180°		180°	
Optimal hydraulic flow	98-130 L/min	26-34 gpm	98-130 L/min	26-34 gpm

*Theoretical values calculated at 100% efficiency.

**Skid Steer Loaders
Multi Terrain Loaders
Compact Track Loaders**

**WorkTools
● Wheel Saws**

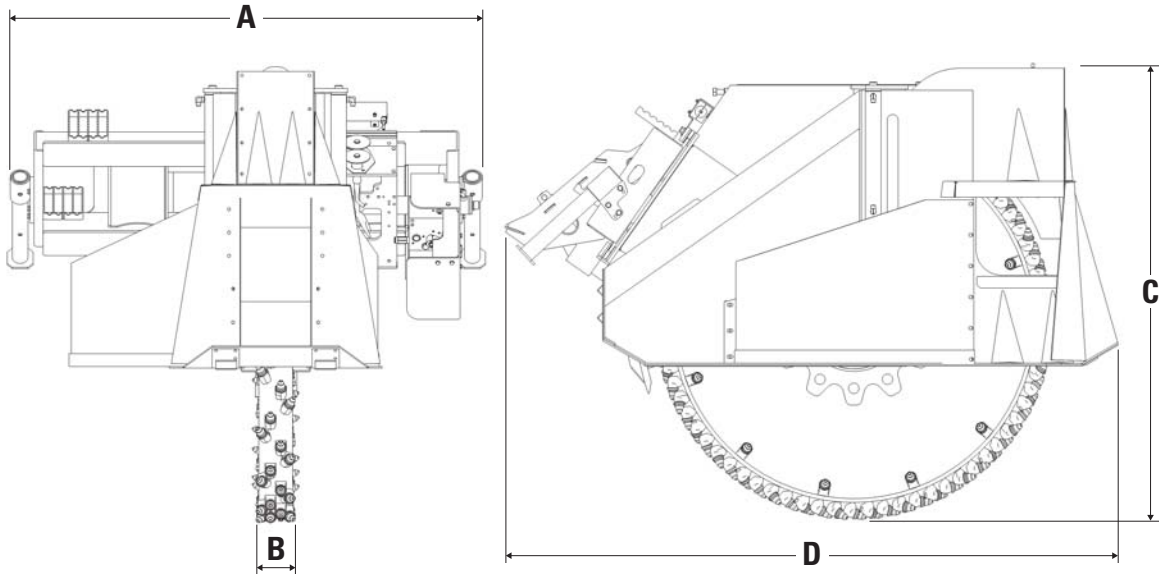

MODEL	SW345B 80 mm (3")		SW360B 80 mm (3")		SW360B 160 mm (6")	
A Overall width	1850 mm	73"	1850 mm	73"	1850 mm	73"
B Wheel width	80 mm	3"	80 mm	3"	160 mm	6"
C Overall height	1455 mm	57"	1765 mm	70"	1765 mm	70"
D Length	2165 mm	85"	2365 mm	93"	2365 mm	93"
Weight	1156 kg	2549 lb	1470 kg	3240 lb	1365 kg	3009 lb
Trench cleaning device	No		No		Yes	
Drive method	Piston motor		Piston motor		Piston motor	
Optimal hydraulic flow	125 L/min	33 gpm	125 L/min	33 gpm	125 L/min	33 gpm
Optimal hydraulic pressure	280 bar	4065 psi	280 bar	4065 psi	280 bar	4065 psi
Wheel torque @ maximum pressure	6244 N·m	4604 lb-ft	7509 N·m	5538 lb-ft	7509 N·m	5538 lb-ft
Wheel speed @ maximum flow	89 RPM		74 RPM		74 RPM	
Bit speed @ maximum flow	349 m/min	1143 ft/min	360 m/min	1180 ft/min	360 m/min	1180 ft/min
Conical bits	64 per wheel		70 per wheel		96 per wheel	
Standard bit type	Concrete		Concrete		Concrete	
Optional bit type	All purpose		All purpose		All purpose	
Maximum depth of cut	450 mm	18"	600 mm	24"	600 mm	24"
Sideshift travel	550 mm	22"	550 mm	22"	550 mm	22"

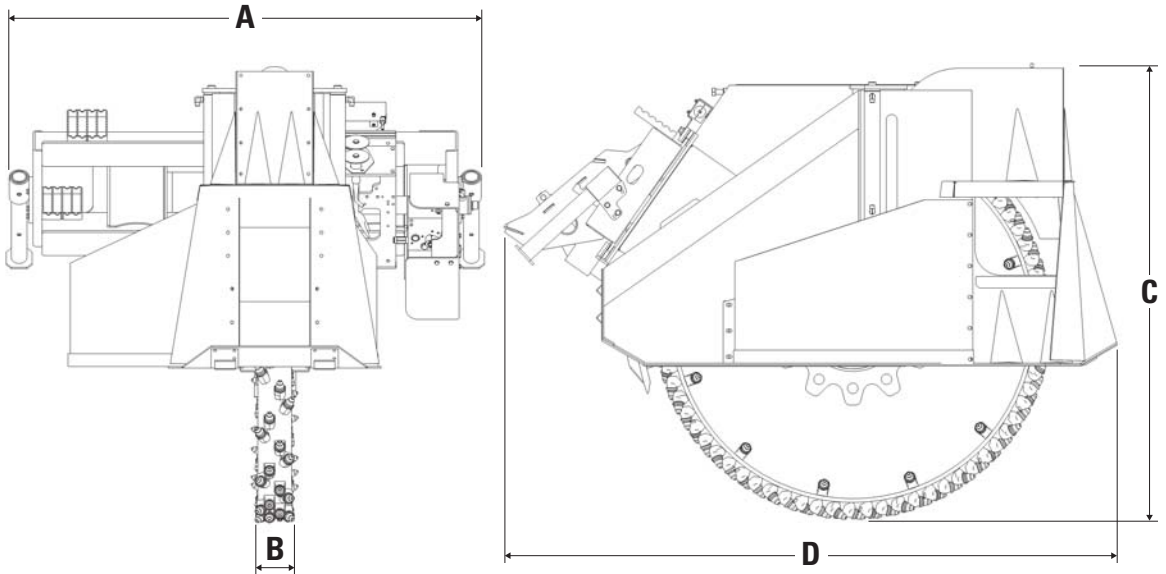

MODEL	SW360B 200 mm (8")		SW380B 250 mm (10")		SW460B 80 mm (3")	
A Overall width	1850 mm	73"	1850 mm	73"	1850 mm	73"
B Wheel width	200 mm	8"	250 mm	10"	80 mm	3"
C Overall height	1765 mm	70"	1950 mm	77"	1765 mm	70"
D Length	2365 mm	93"	2490 mm	98"	2365 mm	93"
Weight	1395 kg	3075 lb	1440 kg	3175 lb	1470 kg	3240 lb
Trench cleaning device	Yes		No		No	
Drive method	Piston motor		Piston motor		Piston motor	
Optimal hydraulic flow	125 L/min	33 gpm	125 L/min	33 gpm	150 L/min	40 gpm
Optimal hydraulic pressure	280 bar	4065 psi	280 bar	4065 psi	280 bar	4065 psi
Wheel torque @ maximum pressure	7509 N·m	5538 lb-ft	7509 N·m	5538 lb-ft	7509 N·m	5538 lb-ft
Wheel speed @ maximum flow	74 RPM		74 RPM		89 RPM	
Bit speed @ maximum flow	360 m/min	1180 ft/min	372 m/min	1228 ft/min	430 m/min	1420 ft/min
Conical bits	96 per wheel		72 per wheel		70 per wheel	
Standard bit type	Concrete		Concrete		Concrete	
Optional bit type	All purpose		All purpose		All purpose	
Maximum depth of cut	600 mm	24"	800 mm	32"	600 mm	24"
Sideshift travel	550 mm	22"	550 mm	22"	550 mm	22"

**Skid Steer Loaders
Multi Terrain Loaders
Compact Track Loaders**

**WorkTools
● Wheel Saws**

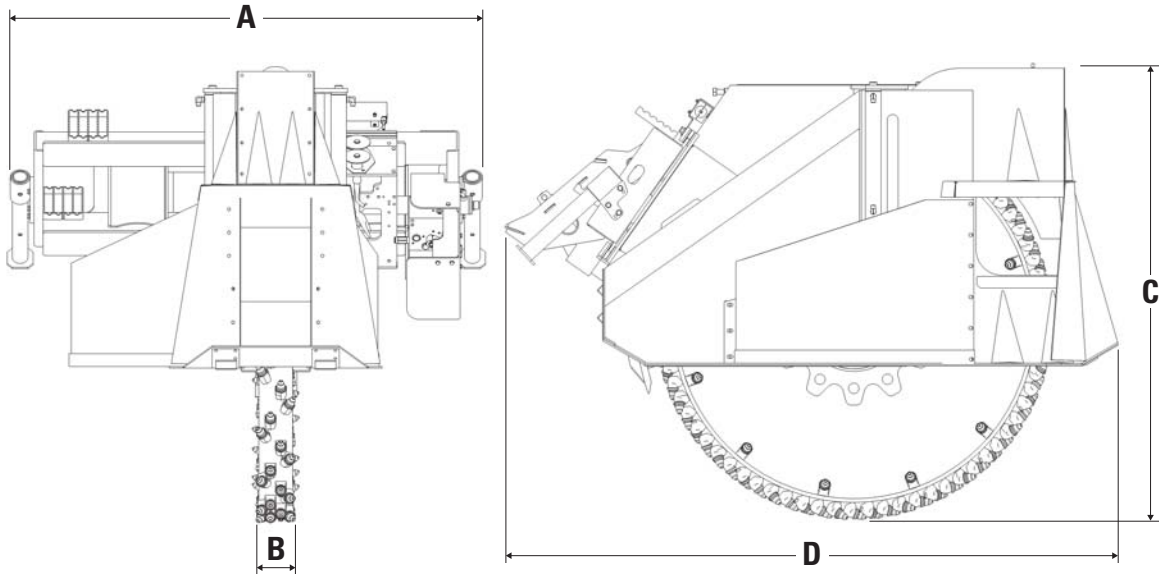

MODEL	SW460B 160 mm (6")		SW460B 200 mm (8")		SW480B 200 mm (8")	
A Overall width	1850 mm	73"	1850 mm	73"	1850 mm	73"
B Wheel width	160 mm	6"	200 mm	8"	250 mm	10"
C Overall height	1765 mm	70"	1765 mm	70"	1950 mm	77"
D Length	2365 mm	93"	2365 mm	93"	2490 mm	98"
Weight	1365 kg	3009 lb	1395 kg	3075 lb	1440 kg	3175 lb
Trench cleaning device	Yes		Yes		No	
Drive method	Piston motor		Piston motor		Piston motor	
Optimal hydraulic flow	150 L/min	40 gpm	150 L/min	40 gpm	150 L/min	40 gpm
Optimal hydraulic pressure	280 bar	4065 psi	280 bar	4065 psi	280 bar	4065 psi
Wheel torque @ maximum pressure	7509 N·m	5538 lb-ft	7509 N·m	5538 lb-ft	7509 N·m	5538 lb-ft
Wheel speed @ maximum flow	89 RPM		89 RPM		89 RPM	
Bit speed @ maximum flow	430 m/min	1420 ft/min	430 m/min	1420 ft/min	447 m/min	1476 ft/min
Conical bits	96 per wheel		96 per wheel		72 per wheel	
Standard bit type	Concrete		Concrete		Concrete	
Optional bit type	All purpose		All purpose		All purpose	
Maximum depth of cut	600 mm	24"	600 mm	24"	800 mm	32"
Sideshift travel	550 mm	22"	550 mm	22"	550 mm	22"

SURFACE MINING EXTRACTION

Draglines

Electric Rope Shovels

Hydraulic Mining Shovels

CONTENTS

DRAGLINES

Introduction	16-3
Safety and Serviceability	16-3
Features	16-4
8000	
Specifications	16-5
Dimensions/Working Ranges	16-6
8200	
Specifications	16-7
Dimensions/Working Ranges	16-8
8750 – 22.9 m (75 ft) Base	
Specifications	16-9
Dimensions/Working Ranges	16-12
8750 – 25.6 m (84 ft) Base	
Specifications	16-15
Dimensions/Working Ranges	16-19
10/10/20 Load Management Policy	16-23

ELECTRIC ROPE SHOVELS

Introduction	16-25
Safety and Serviceability	16-25
Features	16-25
Specifications	16-28
Digging Envelopes	16-31
General Dimensions	16-38
Ground Bearing Pressure	16-45
Dipper Selection	16-46
Truck Match	16-47
10/10/20 Load Management Policy	16-48

Throughout this document, references to Tier 4 Interim/Stage IIIB/Japan 2011 (Tier 4 Interim) include U.S. EPA Tier 4 Interim, EU Stage IIIB, and Japan 2011 (Tier 4 Interim) equivalent emission standards. References to Tier 4 Final/Stage IV/Japan 2014 (Tier 4 Final) include U.S. EPA Tier 4 Final, EU Stage IV, and Japan 2014 (Tier 4 Final) emission standards.

Throughout this document, references to Tier 1/Stage I include U.S. EPA Tier 1 and EU Stage I equivalent emission standards. References to Tier 2/Stage II/Japan 2001 (Tier 2) equivalent include U.S. EPA Tier 2, EU Stage II, and Japan 2001 (Tier 2) equivalent emission standards. References to Tier 3/Stage IIIA/Japan 2006 (Tier 3) equivalent include U.S. EPA Tier 3, EU Stage IIIA, and Japan 2006 (Tier 3) equivalent emission standards.

HYDRAULIC MINING SHOVELS

- General Introduction..... 16-49
- Features 16-50
- Specifications..... 16-51
- Digging Envelopes/Working Range/
 - Digging Forces..... 16-61
- General Dimensions 16-76
- Ground Pressures 16-81
- Bucket Selection 16-84
- Cycle Times 16-85
- Production Overviews..... 16-87

DRAGLINES

CONTENTS

DRAGLINES

Introduction	16-3
Safety and Serviceability	16-3
Features	16-4
8000	
Specifications	16-5
Dimensions/Working Ranges	16-6
8200	
Specifications	16-7
Dimensions/Working Ranges	16-8
8750 – 22.9 m (75 ft) Base	
Specifications	16-9
Dimensions/Working Ranges	16-12
8750 – 25.6 m (84 ft) Base	
Specifications	16-15
Dimensions/Working Ranges	16-19
10/10/20 Load Management Policy	16-23

INTRODUCTION

Draglines are an important excavating tool used in many surface mining operations worldwide. These highly productive machines operate 24 hours a day, seven days a week and are able to reach depths of 79.8 m (262 ft) with capacities up to 116.2 m³ (152 yd³). Offering the lowest material removal cost per tonne (ton) and an average operating life of 40 years, draglines are the most productive and versatile machine in the industry. Caterpillar offers an extensive variety of dragline specifications and on-staff application engineers who will help determine the solution that best addresses specific needs.

With over 100 years of dragline experience and the largest operating fleet of draglines with buckets of 40 m³ (52.3 yd³) and above, coupled with an active installed base of over 300 machines, Cat draglines are the most efficient and proven overburden removal solution.

SAFETY AND SERVICEABILITY

Safety plays an integral role in everything we do at Caterpillar, from our factory floors to our service centers to our clients' mine sites. Caterpillar's commitment to safety is apparent in our product designs, which undergo risk assessments and are designed to meet strict codes and regulations. Stairways, walkways, platforms and access points are incorporated throughout Cat draglines to ensure safe and convenient access for maintenance personnel. With safety and serviceability enhancing features incorporated into the operator cab, structures, surfaces and electrical equipment, among others, Cat draglines were designed with safety in mind.

FEATURES

AC IGBT Electrics

Cat draglines are equipped with AC IGBT electrics which allow for greater machine uptime, lower operating costs, and faster cycle times, with AC providing 10% energy savings over the life of the machine.

- **Superior availability:** AC IGBT electric draglines have routinely demonstrated electrical availabilities of greater than 95%.
- **Greater reliability:** Fewer components including interchangeable inverters. IGBT systems require no fuses or circuit breakers.
- **Reduced maintenance:** No regular maintenance is required on IGBT power control modules. Motor maintenance on AC machines is reduced to greasing and replacing bearings every 30,000 hours.
- **Reduced inventory:** Hoist, drag, swing, and propel motions are all controlled by AC motors. Cat IGBT is a mine quality system with rugged welded cabinets to withstand harsh mining conditions.

Major Structures

Cat major structures are designed for extended performance in harsh mining conditions. Structures are manufactured using impact-resistant, high-strength steel with select welds of full-penetration, profiled and ground type. All structural welds undergo visual inspection, with critical welds also receiving MT, UT or X-ray inspection. Large furnaces are used to stress-relieve entire weldments for reduced susceptibility to cracking. Interiors of finished structures are painted white to facilitate field inspection.

Tri-Structure Design

The exclusive tri-structure design on Cat draglines reduces front end weight to enable optimization of boom configurations, allowing for increased load and reach. The tri-structure is manufactured with high impact strength steel for a simplified wide flange beam construction, and less maintenance points are required in comparison with an A-frame or mast assembly. Inventory stocking needs are reduced as the sheaves are interchangeable with both the fairlead and boom assemblies.

Cat Cab

Cat's state-of-the-art operator's cab is the product of a multi-year collaboration between Caterpillar, mining companies and operators. The cab provides industry-leading visibility with excellent line of sight supplemented by five optimally-mounted cameras and display screens. It provides enhanced safety through dual access/egress doors and an optimally-placed trainer seat with independent emergency stop. Additionally, the cab offers the smoothest, most comfortable ride available with an ergonomic, adjustable operator's seat with a fully pneumatic suspension system, low-effort joysticks and dual display screens optimized for operator comfort.

Custom Design and Aftermarket Support

The Cat dragline model selection process is grounded in analysis and collaboration with experienced application engineering professionals and a dragline optimization process to assist in determining the configuration optimally suited for a particular application. Additionally, mechanical and electrical upgrades, and component rebuilds are available to ensure productivity and reliability for the life of the machine. Caterpillar also offers machine relocation and field assembly services supported by experienced industry experts.

MODEL	8000					
Boom Length	76.2 m	250'0"	93.0 m	305'0"	96.0 m	315'0"
Boom Angle	32°		38°		33°	
Rated Suspension Load	95 254 kg	210,000 lb	92 986 kg	205,000 lb	79 379 kg	175,000 lb
Weights*						
Net Weight, Domestic (approximate with bucket)	1 469 639 kg	3,240,000 lb	1 542 214 kg	3,400,000 lb	1 610 253 kg	3,550,000 lb
Working Weight (approximate with bucket)	1 769 010 kg	3,900,000 lb	1 927 768 kg	4,250,000 lb	1 995 806 kg	4,400,000 lb
Ballast Weight (approximate)	299 371 kg	660,000 lb	385 554 kg	850,000 lb	385 554 kg	850,000 lb
Drag Rope						
Drum Diameter	243.8 cm	96"	243.8 cm	96"	243.8 cm	96"
Number	2		2		2	
Rope Diameter	6.99 cm	2.75"	6.99 cm	2.75"	6.99 cm	2.75"
Hoist Rope						
Drum Diameter	243.8 cm	96"	243.8 cm	96"	243.8 cm	96"
Number	2		2		2	
Rope Diameter	6.99 cm	2.75"	6.99 cm	2.75"	6.99 cm	2.75"
Electrical						
IGBT-AFE Inverter Cabinets	(2) water cooled		(2) water cooled		(2) water cooled	
Hoist Motors	(2) × 1230 kW	(2) × 1650 hp	(2) × 1230 kW	(2) × 1650 hp	(2) × 1230 kW	(2) × 1650 hp
Drag Motors	(2) × 1230 kW	(2) × 1650 hp	(2) × 1230 kW	(2) × 1650 hp	(2) × 1230 kW	(2) × 1650 hp
Swing Motors	(2) × 932 kW	(2) × 1250 hp	(2) × 932 kW	(2) × 1250 hp	(2) × 932 kW	(2) × 1250 hp
Walking Motors	Common shaft clutched off one drag motor		Common shaft clutched off one drag motor		Common shaft clutched off one drag motor	
Base						
Outside Diameter	15.5 m	51'0"	15.5 m	51'0"	15.5 m	51'0"
Bearing Area	189.8 m ²	2043 ft²	189.8 m ²	2043 ft²	189.8 m ²	2043 ft²
Bearing Pressure*	91.4 kPa	13.3 psi	91.6 kPa	14.4 psi	103.1 kPa	15.0 psi
Circle Rail Diameter	15.2 m	50'0"	15.2 m	50'0"	15.2 m	50'0"
Rollers (average diameter)	26 cm	10.25"	26 cm	10.25"	26 cm	10.25"
Swing Gear (pitch diameter)	12.9 m	42'5"	12.9 m	42'5"	12.9 m	42'5"
Walking Mounting						
Shoe Width and Length	2.7 m × 16.8 m	9'0" × 55'0"	2.7 m × 16.8 m	9'0" × 55'0"	2.7 m × 16.8 m	9'0" × 55'0"
Combined Bearing Area	92 m ²	990 ft²	92 m ²	990 ft²	92 m ²	990 ft²
Bearing Pressure (@ 80% working weight)	150.9 kPa	21.9 psi	164.4 kPa	23.8 psi	170.2 kPa	24.7 psi
Overall Width over Shoes	21.6 m	71'0"	21.6 m	71'0"	21.6 m	71'0"
Length of Step (approximate)	2.13 m	7'0"	2.13 m	7'0"	2.13 m	7'0"
Bucket Capacity	32 m ³	42 yd³	31 m ³	41 yd³	27 m ³	35 yd³

*Net weight, ballast weight, working weight, bearing pressure (kPa/psi) will vary with boom length, angle, and rated suspended load.

NOTE: Motor combinations and IGBT-AFE Inverter Cabinets vary with boom length, angle, and rated suspension load.

The 83.8 m (275'0") boom option has a mast.

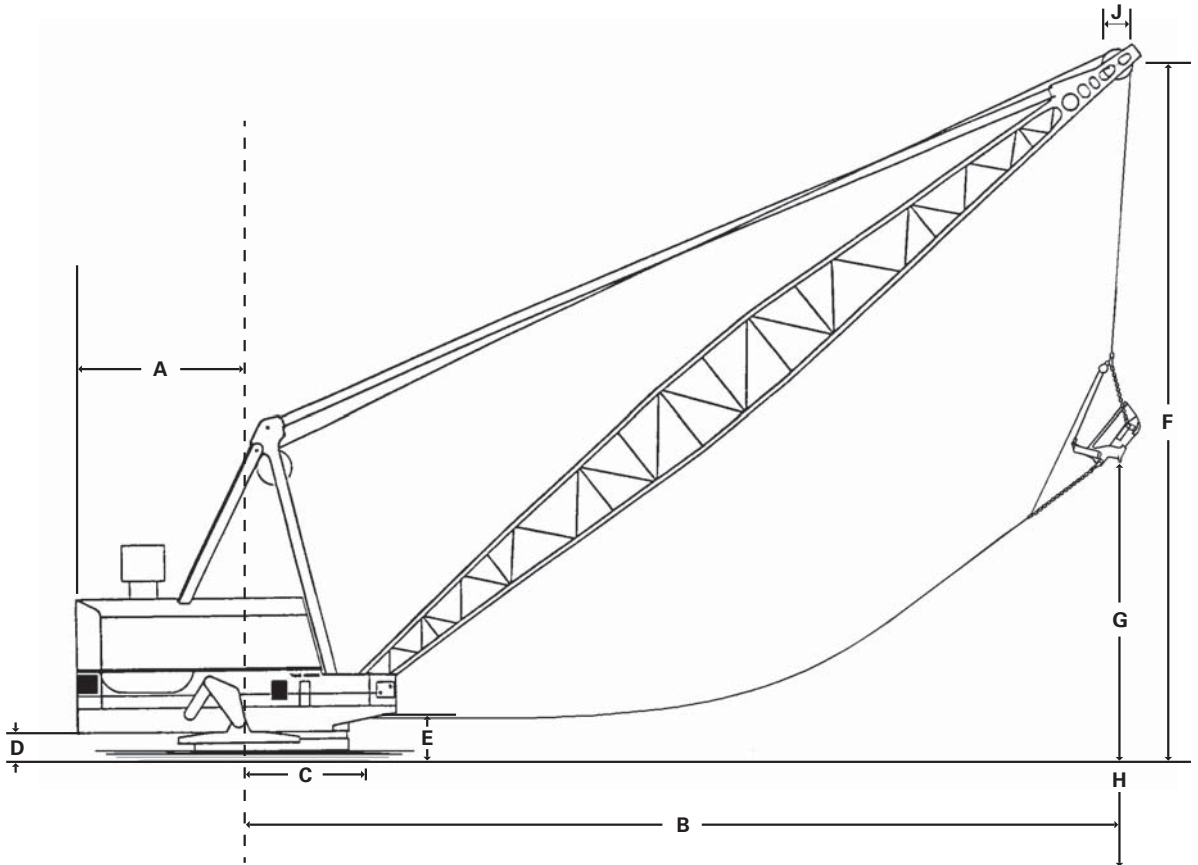

MODEL

8000

	76.2 m	250'0"	93.0 m	305'0"	96.0 m	315'0"
Boom Length						
Boom Angle	32°		38°		33°	
Rated Suspension Load	95 254 kg	210,000 lb	92 986 kg	205,000 lb	79 379 kg	175,000 lb
Dimensions/Working Ranges						
A Clearance Radius	16.8 m	55'3"	16.8 m	55'3"	16.8 m	55'3"
B Operating Radius	71.9 m	236'0"	79.9 m	262'0"	88.1 m	289'0"
C Boom Foot Radius	6.2 m	20'3"	6.2 m	20'3"	6.2 m	20'3"
D Clearance Height	1.8 m	5'9"	1.8 m	5'9"	1.8 m	5'9"
E Boom Foot Height	4.1 m	13'6"	4.1 m	13'6"	4.1 m	13'6"
F Boom Point Height	44.5 m	146'0"	62.2 m	204'0"	56.0 m	183'8"
G Dumping Height	32.3 m	106'0"	50.0 m	164'0"	44.2 m	145'0"
H Digging Depth	62.2 m	204'0"	44.5 m	146'0"	50.3 m	165'0"
J Point Sheave Pitch Diameter	228.6 cm	90"	228.6 cm	90"	228.6 cm	90"

NOTE: The 83.8 m (275'0") and 96 m (315'0") boom options have a mast.

MODEL	8200											
	100 m		328'0"		100 m		328'0"		100 m		328'0"	
Boom Length												
Boom Angle	39°		35°		32°							
Rated Suspension Load	181 437 kg	400,000 lb	181 437 kg	400,000 lb	172 365 kg	380,000 lb						
Weights*												
Net Weight, Domestic (approximate with bucket)	3 492 661 kg	7,700,000 lb	3 492 661 kg	7,700,000 lb	3 488 125 kg	7,690,000 lb						
Working Weight (approximate with bucket)	4 123 155 kg	9,090,000 lb	4 173 050 kg	9,200,000 lb	4 139 938 kg	9,127,000 lb						
Ballast Weight (approximate)	630 493 kg	1,390,000 lb	680 389 kg	1,500,000 lb	651 812 kg	1,437,000 lb						
Drag Rope												
Drum Diameter	254 cm	100"	254 cm	100"	254 cm	100"						
Number	2		2		2							
Rope Diameter	9.525 cm	3.750"	9.525 cm	3.750"	9.525 cm	3.750"						
Hoist Rope												
Drum Diameter	254 cm	100"	254 cm	100"	254 cm	100"						
Number	2		2		2							
Rope Diameter	9.525 cm	3.750"	9.525 cm	3.750"	9.525 cm	3.750"						
Electrical												
IGBT-AFE Inverter Cabinets	(2) water cooled		(2) water cooled		(2) water cooled							
Hoist Motors	(4) × 1230 kW	(4) × 1650 applied hp	(4) × 1230 kW	(4) × 1650 applied hp	(4) × 1230 kW	(4) × 1650 applied hp						
Drag Motors	(4) × 1230 kW	(4) × 1650 applied hp	(4) × 1230 kW	(4) × 1650 applied hp	(4) × 1230 kW	(4) × 1650 applied hp						
Swing Motors	(4) × 932 kW	(4) × 1250 applied hp	(4) × 932 kW	(4) × 1250 applied hp	(4) × 932 kW	(4) × 1250 applied hp						
Walking Motors	(2) × 932 kW	(2) × 1250 applied hp	(2) × 932 kW	(2) × 1250 applied hp	(2) × 932 kW	(2) × 1250 applied hp						
Base												
Outside Diameter	19.5 m	64'0"	19.5 m	64'0"	19.5 m	64'0"						
Bearing Area	298.9 m ²	3217 ft²	298.9 m ²	3217 ft²	298.9 m ²	3217 ft²						
Bearing Pressure*	131-144.8 kPa	19-21 psi	131-144.8 kPa	19-21 psi	131-144.8 kPa	19-21 psi						
Circle Rail Diameter	15.2 m	50'0"	15.2 m	50'0"	15.2 m	50'0"						
Rollers (average diameter)	30.5 cm	12"	30.5 cm	12"	30.5 cm	12"						
Swing Gear (pitch diameter)	130.3 m	42'9"	130.3 m	42'9"	130.3 m	42'9"						
Walking Mounting												
Shoe Width and Length	3.9 m × 19.8 m	13'0" × 65'0"	3.9 m × 19.8 m	13'0" × 65'0"	3.9 m × 19.8 m	13'0" × 65'0"						
Combined Bearing Area	157 m ²	1690 ft²	157 m ²	1690 ft²	157 m ²	1690 ft²						
Bearing Pressure (@ 80% of working weight)	191.7-208.5 kPa	27.80-30.24 psi	191.7-208.5 kPa	27.80-30.24 psi	191.7-208.5 kPa	27.80-30.24 psi						
Overall Width over Shoes	29.5 m	97'0"	29.5 m	97'0"	29.5 m	97'0"						
Length of Step (approximate)	2.26 m	7'5"	2.26 m	7'5"	2.26 m	7'5"						
Bucket Capacity	46-61 m ³	60-80 yd³	46-61 m ³	60-80 yd³	46-61 m ³	60-80 yd³						

*Net weight, ballast weight, working weight, bearing pressure (kPa/psi) will vary with boom length, angle, and rated suspended load.
NOTE: Motor combinations and IGBT-AFE Inverter Cabinets vary with boom length, angle, and rated suspension load.

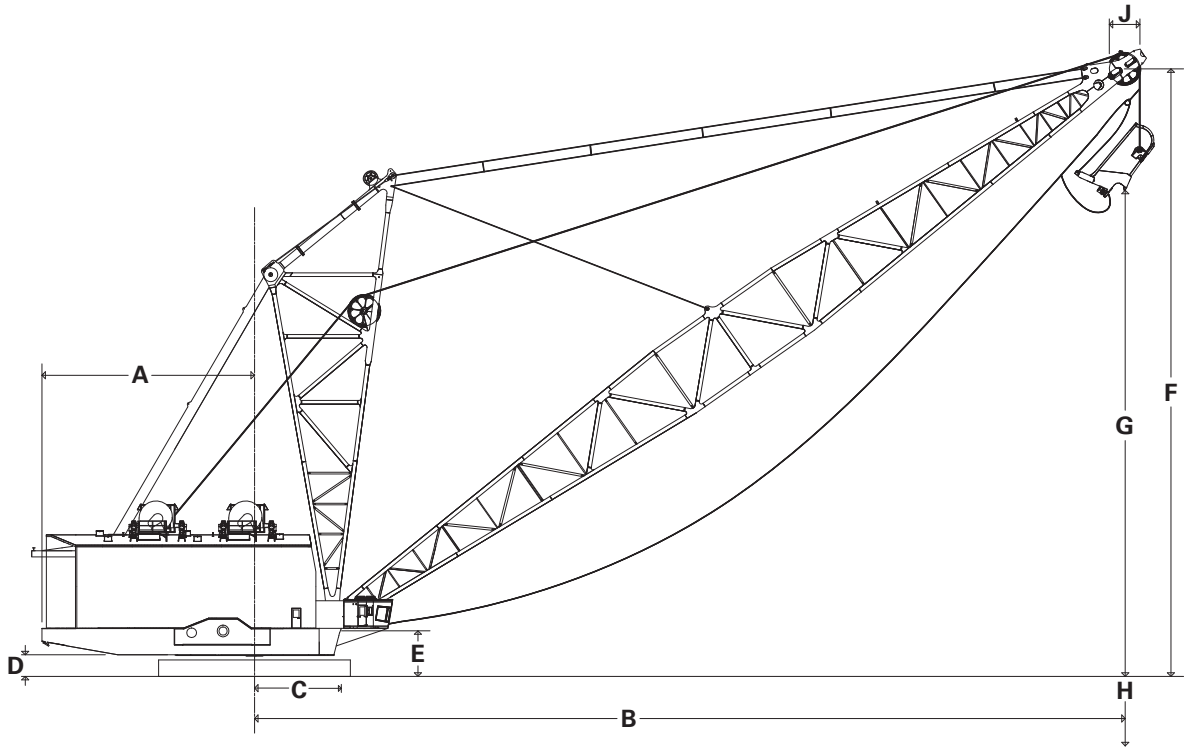

MODEL

8200

	100 m	328'0"	100 m	328'0"	100 m	328'0"
Boom Length	100 m	328'0"	100 m	328'0"	100 m	328'0"
Boom Angle	39°		35°		32°	
Rated Suspension Load	181 437 kg	400,000 lb	181 437 kg	400,000 lb	172 365 kg	380,000 lb
Dimensions/Working Ranges						
A Clearance Radius	21.6 m	71'0"	21.6 m	71'0"	21.6 m	71'0"
B Operating Radius	85.6 m	281'0"	90.1 m	295'5"	92.7 m	304'0"
C Boom Foot Radius	6.6 m	21'6"	6.6 m	21'6"	6.6 m	21'6"
D Clearance Height	2.2 m	7'3"	2.2 m	7'3"	2.2 m	7'3"
E Boom Foot Height	4.7 m	15'3"	4.7 m	15'3"	4.7 m	15'3"
F Boom Point Height	67.6 m	221'7"	61.9 m	203'0"	57.6 m	189'1"
G Dumping Height	49.4 m	162'0"	43.6 m	143'0"	39.3 m	129'0"
H Digging Depth	40.5 m	133'0"	46.3 m	152'0"	50.6 m	166'0"
J Point Sheave Pitch Diameter	304.8 cm	120"	304.8 cm	120"	304.8 cm	120"

MODEL	8750 – 22.9 m (75'0") Base			
Boom Length	109.7 m	360'0"	109.7 m	360'0"
Boom Angle	39°		35°	
Rated Suspension Load	294 840 kg	650,000 lb	294 840 kg	650,000 lb
Weights*				
Net Weight, Domestic (approximate with bucket)	5 502 075 kg	12,130,000 lb		*
Working Weight (approximate with bucket)	5 955 668 kg	13,130,000 lb		*
Ballast Weight (approximate)	453 592 kg	1,000,000 lb		*
Drag Rope				
Drum Diameter	317.5 cm	125"	317.5 cm	125"
Number		2		2
Rope Diameter	11.8 cm	4.63"	11.8 cm	4.63"
Hoist Rope				
Drum Diameter	317.5 cm	125"	317.5 cm	125"
Number		2		2
Rope Diameter	11.8 cm	4.63"	11.8 cm	4.63"
Electrical				
IGBT-AFE Inverter Cabinets	(4) or (5) water cooled		(4) or (5) water cooled	
Hoist Motors	(6) to (8) × 1230 kW	(6) to (8) × 1650 applied hp	(6) to (8) × 1230 kW	(6) to (8) × 1650 applied hp
Drag Motors	(6) to (8) × 1230 kW	(6) to (8) × 1650 applied hp	(6) to (8) × 1230 kW	(6) to (8) × 1650 applied hp
Swing Motors	(7) to (8) × 932 kW	(7) to (8) × 1250 applied hp	(7) to (8) × 932 kW	(7) to (8) × 1250 applied hp
Walking Motors	(4) × 932 kW	(4) × 1250 applied hp	(4) × 932 kW	(4) × 1250 applied hp
Base				
Outside Diameter	22.9 m	75'0"	22.9 m	75'0"
Bearing Area	410.5 m ²	4418 ft ²	410.5 m ²	4418 ft ²
Bearing Pressure*	1379-1475 kPa	20.00-21.40 psi	1379-1475 kPa	20.00-21.40 psi
Circle Rail Diameter	16.8 m	55'0"	16.8 m	55'0"
Rollers (average diameter)	35.6 cm	14"	35.6 cm	14"
Swing Gear (pitch diameter)	13.87 m	45'6"	13.87 m	45'6"
Walking Mounting				
Shoe Width and Length	4.3 m × 21.3 m	14'0" × 70'0"	2.7 m × 14.6 m	14'0" × 70'0"
Combined Bearing Area	182.1 m ²	1960 ft ²	80.3 m ²	1960 ft ²
Bearing Pressure (@ 80% of working weight)	256.5-268.9 kPa	37.2-39.0 psi	21.6 m	37.2-39.0 psi
Overall Width over Shoes	32.3 m	106'0"	2.1 m	106'0"
Length of Step (approximate)	2.13 m	7'0"	0.24 km/h	7'0"
Bucket Capacity	76-116 m ³	100-152 yd ³	76-116 m ³	100-152 yd ³

*Net weight, ballast weight, working weight, bearing pressure (kPa/psi) will vary with boom length, angle, and rated suspended load.
NOTE: Motor combinations and IGBT-AFE Inverter Cabinets vary with boom length, angle, and rated suspension load.

MODEL	8750 – 22.9 m (75'0") Base					
Boom Length	117.3 m	385'0"	117.3 m	385'0"	117.3 m	385'0"
Boom Angle	39°		35°		32°	
Rated Suspension Load	278 964 kg	615,000 lb	278 964 kg	615,000 lb	263 088 kg	580,000 lb
Weights*						
Net Weight, Domestic (approximate with bucket)	5 497 540 kg	12,120,000 lb	*	*	*	*
Working Weight (approximate with bucket)	6 078 138 kg	13,400,000 lb	*	*	*	*
Ballast Weight (approximate)	580 598 kg	1,280,000 lb	*	*	*	*
Drag Rope						
Drum Diameter	317.5 cm	125"	317.5 cm	125"	317.5 cm	125"
Number	2		2		2	
Rope Diameter	11.8 cm	4.63"	11.8 cm	4.63"	11.4 cm	4.5"
Hoist Rope						
Drum Diameter	317.5 cm	125"	317.5 cm	125"	317.5 cm	125"
Number	2		2		2	
Rope Diameter	11.8 cm	4.63"	11.8 cm	4.63"	11.4 cm	4.5"
Electrical						
IGBT-AFE Inverter Cabinets	(4) or (5) water cooled		(4) or (5) water cooled		(4) or (5) water cooled	
Hoist Motors	(6) to (8) x 1230 kW	(6) to (8) x 1650 applied hp	(6) to (8) x 1230 kW	(6) to (8) x 1650 applied hp	(6) to (8) x 1230 kW	(6) to (8) x 1650 applied hp
Drag Motors	(6) to (8) x 1230 kW	(6) to (8) x 1650 applied hp	(6) to (8) x 1230 kW	(6) to (8) x 1650 applied hp	(6) to (8) x 1230 kW	(6) to (8) x 1650 applied hp
Swing Motors	(7) to (8) x 932 kW	(7) to (8) x 1250 applied hp	(7) to (8) x 932 kW	(7) to (8) x 1250 applied hp	(7) to (8) x 932 kW	(7) to (8) x 1250 applied hp
Walking Motors	(4) x 932 kW	(4) x 1250 applied hp	(4) x 932 kW	(4) x 1250 applied hp	(4) x 932 kW	(4) x 1250 applied hp
Base						
Outside Diameter	22.9 m	75'0"	22.9 m	75'0"	22.9 m	75'0"
Bearing Area	410.5 m ²	4418 ft ²	410.5 m ²	4418 ft ²	410.5 m ²	4418 ft ²
Bearing Pressure*	137.9-147.5 kPa	20.00-21.40 psi	137.9-147.5 kPa	20.00-21.40 psi	137.9-147.5 kPa	20.00-21.40 psi
Circle Rail Diameter	16.8 m	55'0"	16.8 m	55'0"	16.8 m	55'0"
Rollers (average diameter)	35.6 cm	14"	35.6 cm	14"	35.6 cm	14"
Swing Gear (pitch diameter)	13.87 m	45'6"	13.87 m	45'6"	13.87 m	45'6"
Walking Mounting						
Shoe Width and Length	4.3 m x 21.3 m	14'0" x 70'0"	4.3 m x 21.3 m	14'0" x 70'0"	4.3 m x 21.3 m	14'0" x 70'0"
Combined Bearing Area	182.1 m ²	1960 ft ²	182.1 m ²	1960 ft ²	182.1 m ²	1960 ft ²
Bearing Pressure (@ 80% of working weight)	256.5-268.9 kPa	37.2-39.0 psi	256.5-268.9 kPa	37.2-39.0 psi	256.5-268.9 kPa	37.2-39.0 psi
Overall Width over Shoes	32.3 m	106'0"	32.3 m	106'0"	32.3 m	106'0"
Length of Step (approximate)	2.13 m	7'0"	2.13 m	7'0"	2.13 m	7'0"
Bucket Capacity	76-116 m ³	100-152 yd ³	76-116 m ³	100-152 yd ³	76-116 m ³	100-152 yd ³

*Net weight, ballast weight, working weight, bearing pressure (kPa/psi) will vary with boom length, angle, and rated suspended load.
 NOTE: Motor combinations and IGBT-AFE Inverter Cabinets vary with boom length, angle, and rated suspension load.

MODEL	8750 – 22.9 m (75'0") Base					
Boom Length	124.9 m 410'0"		124.9 m 410'0"		124.9 m 410'0"	
Boom Angle	39°		35°		32°	
Rated Suspension Load	249 480 kg 550,000 lb		242 676 kg 535,000 lb		226 800 kg 500,000 lb	
Weights*						
Net Weight, Domestic (approximate with bucket)	5 535 188 kg	12,203,000 lb		*		*
Working Weight (approximate with bucket)	6 182 464 kg	13,630,000 lb		*		*
Ballast Weight (approximate)	647 276 kg	1,427,000 lb		*		*
Drag Rope						
Drum Diameter	317.5 cm	125"	317.5 cm	125"	317.5 cm	125"
Number	2		2		2	
Rope Diameter	11.4 cm	4.5"	10.8 cm	4.25"	10.8 cm	4.25"
Hoist Rope						
Drum Diameter	317.5 cm	125"	317.5 cm	125"	317.5 cm	125"
Number	2		2		2	
Rope Diameter	11.4 cm	4.5"	10.8 cm	4.25"	10.8 cm	4.25"
Electrical						
IGBT-AFE Inverter Cabinets	(4) or (5) water cooled		(4) or (5) water cooled		(4) or (5) water cooled	
Hoist Motors	(6) to (8) × 1230 kW	(6) to (8) × 1650 applied hp	(6) to (8) × 1230 kW	(6) to (8) × 1650 applied hp	(6) to (8) × 1230 kW	(6) to (8) × 1650 applied hp
Drag Motors	(6) to (8) × 1230 kW	(6) to (8) × 1650 applied hp	(6) to (8) × 1230 kW	(6) to (8) × 1650 applied hp	(6) to (8) × 1230 kW	(6) to (8) × 1650 applied hp
Swing Motors	(7) to (8) × 932 kW	(7) to (8) × 1250 applied hp	(7) to (8) × 932 kW	(7) to (8) × 1250 applied hp	(7) to (8) × 932 kW	(7) to (8) × 1250 applied hp
Walking Motors	(4) × 932 kW	(4) × 1250 applied hp	(4) × 932 kW	(4) × 1250 applied hp	(4) × 932 kW	(4) × 1250 applied hp
Base						
Outside Diameter	22.9 m	75'0"	22.9 m	75'0"	22.9 m	75'0"
Bearing Area	410.5 m ²	4418 ft²	410.5 m ²	4418 ft²	410.5 m ²	4418 ft²
Bearing Pressure*	137.9-147.5 kPa	20.00-21.40 psi	137.9-147.5 kPa	20.00-21.40 psi	137.9-147.5 kPa	20.00-21.40 psi
Circle Rail Diameter	16.8 m	55'0"	16.8 m	55'0"	16.8 m	55'0"
Rollers (average diameter)	35.6 cm	14"	35.6 cm	14"	35.6 cm	14"
Swing Gear (pitch diameter)	13.87 m	45'6"	13.87 m	45'6"	13.87 m	45'6"
Walking Mounting						
Shoe Width and Length	4.3 m × 21.3 m	14'0" × 70'0"	4.3 m × 21.3 m	14'0" × 70'0"	4.3 m × 21.3 m	14'0" × 70'0"
Combined Bearing Area	182.1 m ²	1960 ft²	182.1 m ²	1960 ft²	182.1 m ²	1960 ft²
Bearing Pressure (@ 80% of working weight)	256.5-268.9 kPa	37.2-39.0 psi	256.5-268.9 kPa	37.2-39.0 psi	256.5-268.9 kPa	37.2-39.0 psi
Overall Width over Shoes	32.3 m	106'0"	32.3 m	106'0"	32.3 m	106'0"
Length of Step (approximate)	2.13 m	7'0"	2.13 m	7'0"	2.13 m	7'0"
Bucket Capacity	76-116 m ³	100-152 yd³	76-116 m ³	100-152 yd³	76-116 m ³	100-152 yd³

*Net weight, ballast weight, working weight, bearing pressure (kPa/psi) will vary with boom length, angle, and rated suspended load.
NOTE: Motor combinations and IGBT-AFE Inverter Cabinets vary with boom length, angle, and rated suspension load.

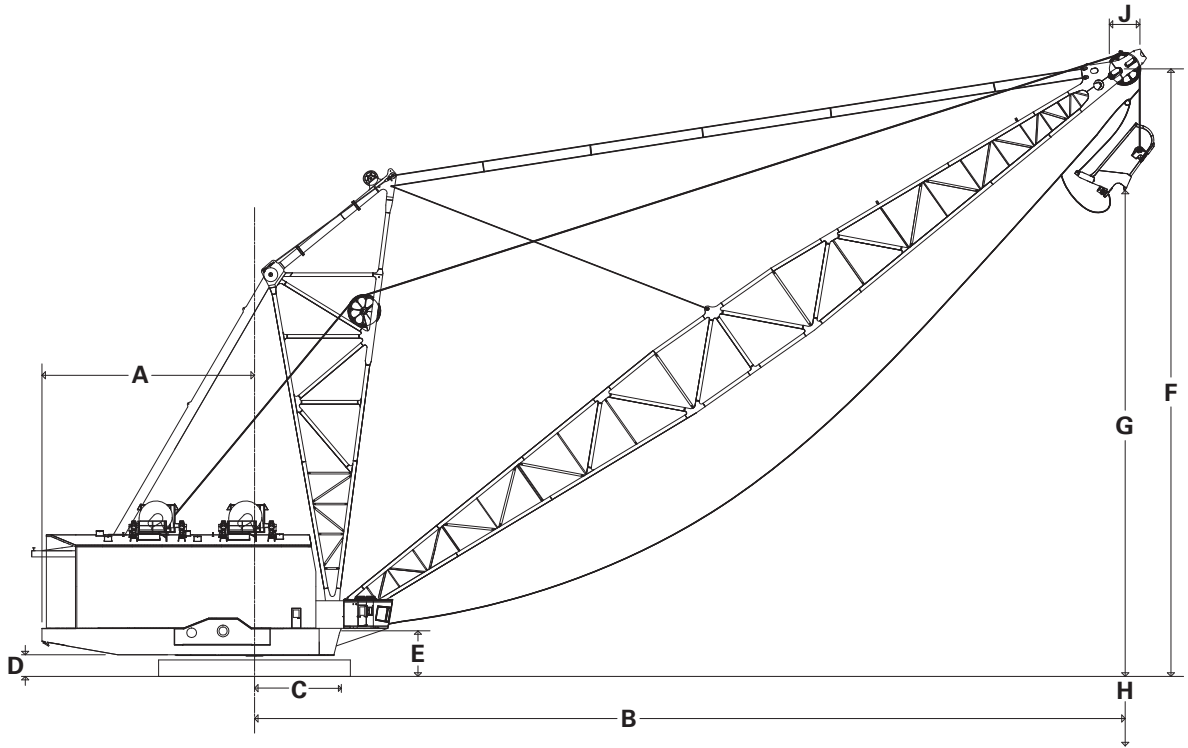

MODEL

8750 – 22.9 m (75'0") Base

	109.7 m	360'0"	109.7 m	360'0"
Boom Length	109.7 m	360'0"	109.7 m	360'0"
Boom Angle	39°		35°	
Rated Suspension Load	294 835 kg	650,000 lb	294 835 kg	650,000 lb
Dimensions/Working Ranges				
A Clearance Radius	27.9 m	91'8"	27.9 m	91'8"
B Operating Radius	94.5 m	310'0"	99.1 m	325'0"
C Boom Foot Radius	7.3 m	24'0"	7.3 m	24'0"
D Clearance Height	4.1 m	13'4"	4.1 m	13'4"
E Boom Foot Height	5.1 m	16'10"	5.1 m	16'10"
F Boom Point Height	74.2 m	243.5'	68.07 m	223.3'
G Dumping Height	52.1 m	171'0"	46.3 m	152'0"
H Digging Depth	60.7 m	199'0"	66.4 m	218'0"
J Point Sheave Pitch Diameter	353.1 cm	139"	353.1 cm	139"

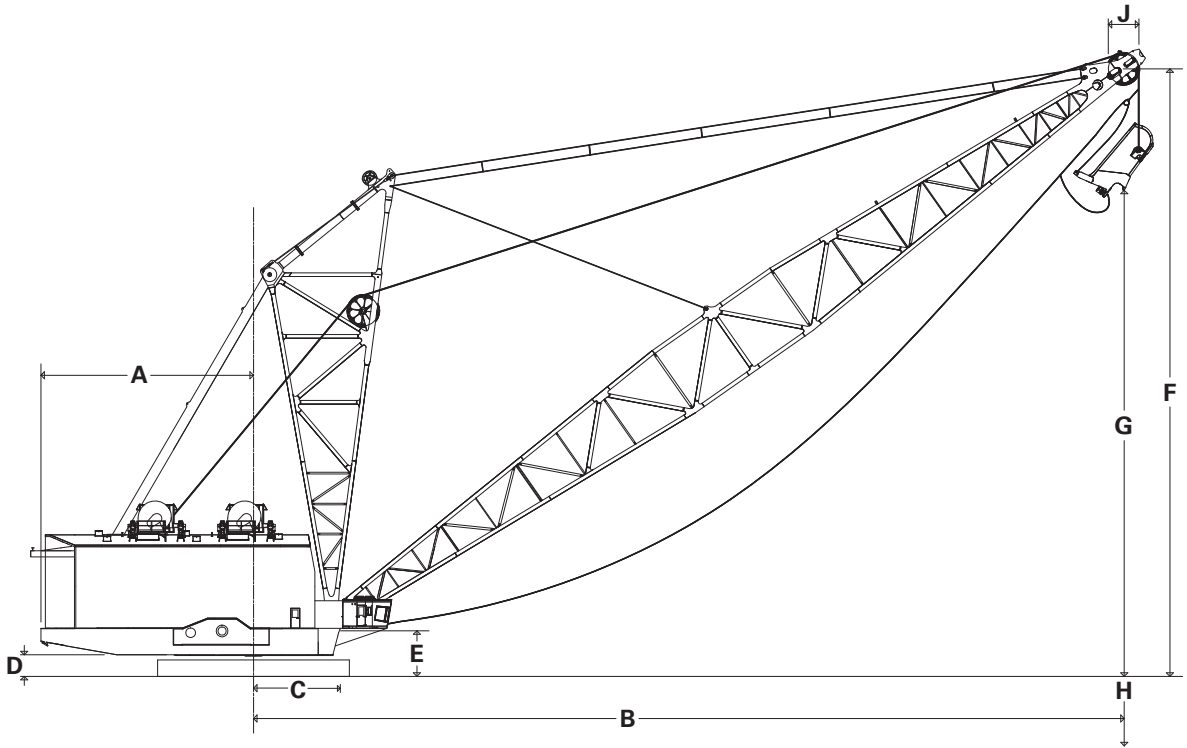

MODEL

8750 – 22.9 m (75'0") Base

	117.3 m	385'0"	117.3 m	385'0"	117.3 m	385'0"
Boom Length	117.3 m	385'0"	117.3 m	385'0"	117.3 m	385'0"
Boom Angle	39°		35°		32°	
Rated Suspension Load	278 964 kg	615,000 lb	278 964 kg	615,000 lb	263 088 kg	580,000 lb
Dimensions/Working Ranges						
A Clearance Radius	27.9 m	91'8"	27.9 m	91'8"	27.9 m	91'8"
B Operating Radius	100.2 m	329'0"	105.1 m	345'0"	108.5 m	356'0"
C Boom Foot Radius	7.3 m	24'0"	7.3 m	24'0"	7.3 m	24'0"
D Clearance Height	4.1 m	13'4"	4.1 m	13'4"	4.1 m	13'4"
E Boom Foot Height	5.1 m	16'10"	5.1 m	16'10"	5.1 m	16'10"
F Boom Point Height	78.9 m	259.1'	72.4 m	237.6'	67.4 m	130.8'
G Dumping Height	57.3 m	188'0"	50.5 m	166'0"	46.3 m	152'0"
H Digging Depth	55.5 m	182'0"	62.2 m	204'0"	66.1 m	217'0"
J Point Sheave Pitch Diameter	353.1 cm	139"	353.1 cm	139"	353.1 cm	139"

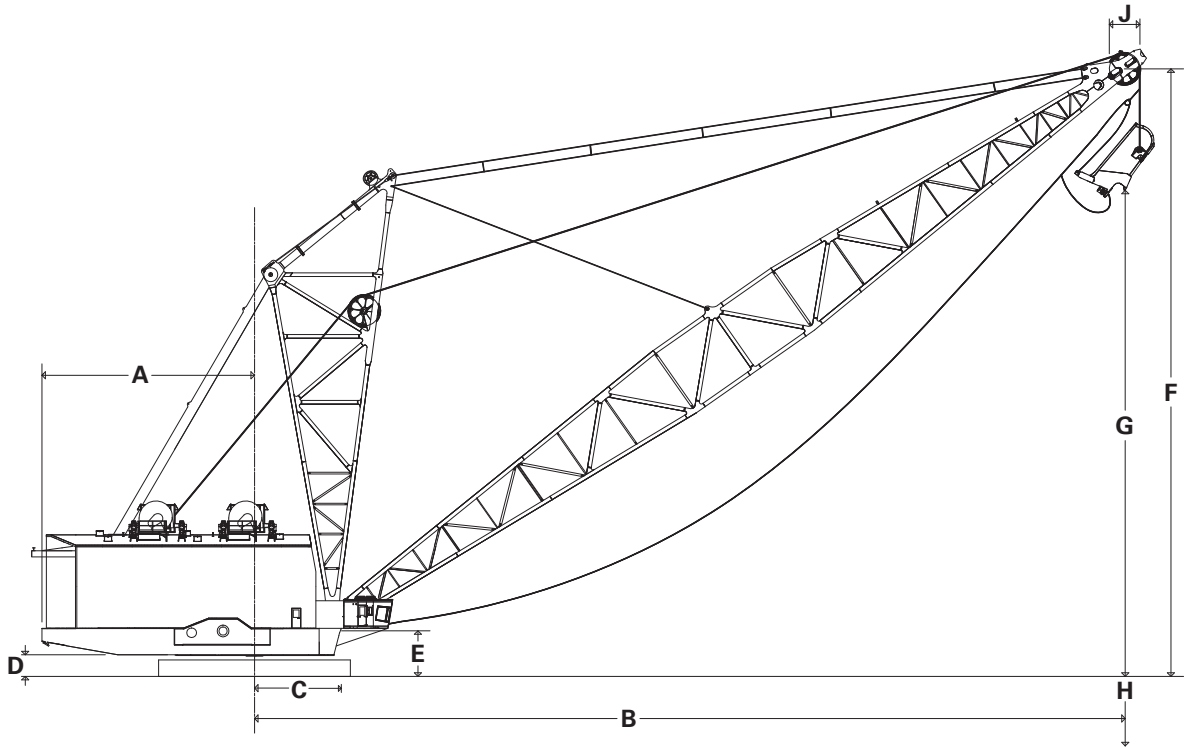

MODEL

8750 – 22.9 m (75'0") Base

	124.9 m	410'0"	124.9 m	410'0"	124.9 m	410'0"
Boom Length	124.9 m	410'0"	124.9 m	410'0"	124.9 m	410'0"
Boom Angle	39°		35°		32°	
Rated Suspension Load	249 480 kg	550,000 lb	242 676 kg	535,000 lb	226 800 kg	500,000 lb
Dimensions/Working Ranges						
A Clearance Radius	27.9 m	91'8"	27.9 m	91'8"	27.9 m	91'8"
B Operating Radius	106.1 m	348'0"	111.5 m	366'0"	114.9 m	377'0"
C Boom Foot Radius	7.3 m	24'0"	7.3 m	24'0"	7.3 m	24'0"
D Clearance Height	4.1 m	13'4"	4.1 m	13'4"	4.1 m	13'4"
E Boom Foot Height	5.1 m	16'10"	5.1 m	16'10"	5.1 m	16'10"
F Boom Point Height	83.7 m	274.8'	76.8 m	252.0'	71.3 m	234.1'
G Dumping Height	62.7 m	206'0"	56.7 m	186'0"	51.2 m	168'0"
H Digging Depth	49.7 m	163'0"	55.8 m	183'0"	61.3 m	201'0"
J Point Sheave Pitch Diameter	353.1 cm	139"	353.1 cm	139"	353.1 cm	139"

MODEL	8750 – 25.6 m (84'0") Base					
Boom Length	109.7 m	360'0"	109.7 m	360'0"	109.7 m	360'0"
Boom Angle	39°		35°		32°	
Rated Suspension Load	344 736 kg	760,000 lb	344 736 kg	760,000 lb	322 056 kg	710,000 lb
Weights*						
Net Weight, Domestic (approximate with bucket)	6 597 500 kg	14,545,000 lb	*	*	*	*
Working Weight (approximate with bucket)	6 876 006 kg	15,159,000 lb	*	*	*	*
Ballast Weight (approximate)	278 505 kg	614,000 lb	*	*	*	*
Drag Rope						
Drum Diameter	330.2 cm	130"	330.2 cm	130"	330.2 cm	130"
Number	2		2		2	
Rope Diameter	13.03 cm	5.13"	13.03 cm	5.13"	12.70 cm	5.00"
Hoist Rope						
Drum Diameter	330.2 cm	130"	330.2 cm	130"	330.2 cm	130"
Number	2		2		2	
Rope Diameter	13.03 cm	5.13"	13.03 cm	5.13"	12.70 cm	5.00"
Electrical						
IGBT-AFE Inverter Cabinets	(4) or (5) water cooled		(4) or (5) water cooled		(4) or (5) water cooled	
Hoist Motors	(6) to (8) x 1230 kW	(6) to (8) x 1650 applied hp	(6) to (8) x 1230 kW	(6) to (8) x 1650 applied hp	(6) to (8) x 1230 kW	(6) to (8) x 1650 applied hp
Drag Motors	(6) to (8) x 1230 kW	(6) to (8) x 1650 applied hp	(6) to (8) x 1230 kW	(6) to (8) x 1650 applied hp	(6) to (8) x 1230 kW	(6) to (8) x 1650 applied hp
Swing Motors	(8) to (10) x 932 kW	(8) to (10) x 1250 applied hp	(8) to (10) x 932 kW	(8) to (10) x 1250 applied hp	(8) to (10) x 932 kW	(8) to (10) x 1250 applied hp
Walking Motors	(4) x 932 kW	(4) x 1250 applied hp	(4) x 932 kW	(4) x 1250 applied hp	(4) x 932 kW	(4) x 1250 applied hp
Base						
Outside Diameter	25.6 m	84'0"	25.6 m	84'0"	25.6 m	84'0"
Bearing Area	514.85 m ²	5542 ft ²	514.85 m ²	5542 ft ²	514.85 m ²	5542 ft ²
Bearing Pressure*	131.0-140.6 kPa	19.00-20.39 psi	131.0-140.6 kPa	19.00-20.39 psi	131.0-140.6 kPa	19.00-20.39 psi
Circle Rail Diameter	16.8 m	55'0"	16.8 m	55'0"	16.8 m	55'0"
Rollers (average diameter)	40.6 cm	16"	40.6 cm	16"	40.6 cm	16"
Swing Gear (pitch diameter)	13.87 m	45'6"	13.87 m	45'6"	13.87 m	45'6"
Walking Mounting						
Shoe Width and Length	4.9 m x 24.4 m	16'0" x 80'0"	4.9 m x 24.4 m	16'0" x 80'0"	4.9 m x 24.4 m	16'0" x 80'0"
Combined Bearing Area	237.8 m ²	2560 ft ²	237.8 m ²	2560 ft ²	237.8 m ²	2560 ft ²
Bearing Pressure (@ 80% of working weight)	226.8-243.5 kPa	32.90-35.32 psi	226.8-243.5 kPa	32.90-35.32 psi	226.8-243.5 kPa	32.90-35.32 psi
Overall Width over Shoes	37.08 m	121'8"	37.08 m	121'8"	37.08 m	121'8"
Length of Step (approximate)	2.28 m	7'6"	2.28 m	7'6"	2.28 m	7'6"
Bucket Capacity	76-116 m ³	100-152 yd ³	76-116 m ³	100-152 yd ³	76-116 m ³	100-152 yd ³

*Net weight, ballast weight, working weight, bearing pressure (kPa/psi) will vary with boom length, angle, and rated suspended load.
NOTE: Motor combinations and IGBT-AFE Inverter Cabinets vary with boom length, angle, and rated suspension load.

MODEL	8750 – 25.6 m (84'0") Base					
Boom Length	117.3 m	385'0"	117.3 m	385'0"	117.3 m	385'0"
Boom Angle	39°		35°		32°	
Rated Suspension Load	344 736 kg	760,000 lb	344 736 kg	760,000 lb	283 500 kg	625,000 lb
Weights*						
Net Weight, Domestic (approximate with bucket)	6 705 000 kg	14,782,000 lb	*	*	*	*
Working Weight (approximate with bucket)	7 125 480 kg	15,709,000 lb	*	*	*	*
Ballast Weight (approximate)	420 480 kg	927,000 lb	*	*	*	*
Drag Rope						
Drum Diameter	330.2 cm	130"	330.2 cm	130"	330.2 cm	130"
Number	2		2		2	
Rope Diameter	13.03 cm	5.13"	13.03 cm	5.13"	11.76 cm	4.63"
Hoist Rope						
Drum Diameter	330.2 cm	130"	330.2 cm	130"	330.2 cm	130"
Number	2		2		2	
Rope Diameter	13.03 cm	5.13"	13.03 cm	5.13"	11.76 cm	4.63"
Electrical						
IGBT-AFE Inverter Cabinets	(4) or (5) water cooled		(4) or (5) water cooled		(4) or (5) water cooled	
Hoist Motors	(6) to (8) x 1230 kW	(6) to (8) x 1650 applied hp	(6) to (8) x 1230 kW	(6) to (8) x 1650 applied hp	(6) to (8) x 1230 kW	(6) to (8) x 1650 applied hp
Drag Motors	(6) to (8) x 1230 kW	(6) to (8) x 1650 applied hp	(6) to (8) x 1230 kW	(6) to (8) x 1650 applied hp	(6) to (8) x 1230 kW	(6) to (8) x 1650 applied hp
Swing Motors	(8) to (10) x 932 kW	(8) to (10) x 1250 applied hp	(8) to (10) x 932 kW	(8) to (10) x 1250 applied hp	(8) to (10) x 932 kW	(8) to (10) x 1250 applied hp
Walking Motors	(4) x 932 kW	(4) x 1250 applied hp	(4) x 932 kW	(4) x 1250 applied hp	(4) x 932 kW	(4) x 1250 applied hp
Base						
Outside Diameter	25.6 m	84'0"	25.6 m	84'0"	25.6 m	84'0"
Bearing Area	514.85 m ²	5542 ft ²	514.85 m ²	5542 ft ²	514.85 m ²	5542 ft ²
Bearing Pressure*	131.0-140.6 kPa	19.00-20.39 psi	131.0-140.6 kPa	19.00-20.39 psi	131.0-140.6 kPa	19.00-20.39 psi
Circle Rail Diameter	16.8 m	55'0"	16.8 m	55'0"	16.8 m	55'0"
Rollers (average diameter)	40.6 cm	16"	40.6 cm	16"	40.6 cm	16"
Swing Gear (pitch diameter)	13.87 m	45'6"	13.87 m	45'6"	13.87 m	45'6"
Walking Mounting						
Shoe Width and Length	4.9 m x 24.4 m	16'0" x 80'0"	4.9 m x 24.4 m	16'0" x 80'0"	4.9 m x 24.4 m	16'0" x 80'0"
Combined Bearing Area	237.8 m ²	2560 ft ²	237.8 m ²	2560 ft ²	237.8 m ²	2560 ft ²
Bearing Pressure (@ 80% of working weight)	226.8-243.5 kPa	32.90-35.32 psi	226.8-243.5 kPa	32.90-35.32 psi	226.8-243.5 kPa	32.90-35.32 psi
Overall Width over Shoes	37.08 m	121'8"	37.08 m	121'8"	37.08 m	121'8"
Length of Step (approximate)	2.28 m	7'6"	2.28 m	7'6"	2.28 m	7'6"
Bucket Capacity	76-116 m ³	100-152 yd ³	76-116 m ³	100-152 yd ³	76-116 m ³	100-152 yd ³

*Net weight, ballast weight, working weight, bearing pressure (kPa/psi) will vary with boom length, angle, and rated suspended load.
 NOTE: Motor combinations and IGBT-AFE Inverter Cabinets vary with boom length, angle, and rated suspension load.

MODEL	8750 – 25.6 m (84'0") Base					
Boom Length	124.9 m	410'0"	124.9 m	410'0"	124.9 m	410'0"
Boom Angle	39°		35°		32°	
Rated Suspension Load	306 180 kg	675,000 lb	317 520 kg	700,000 lb	272 160 kg	600,000 lb
Weights*						
Net Weight, Domestic (approximate with bucket)	6 709 992 kg	14,793,000 lb	*	*	*	*
Working Weight (approximate with bucket)	7 223 005 kg	15,924,000 lb	*	*	*	*
Ballast Weight (approximate)	513 013 kg	1,131,000 lb	*	*	*	*
Drag Rope						
Drum Diameter	330.2 cm	130"	330.2 cm	130"	330.2 cm	130"
Number	2		2		2	
Rope Diameter	12.06 cm	4.75"	12.70 cm	5.00"	11.76 cm	4.63"
Hoist Rope						
Drum Diameter	330.2 cm	130"	330.2 cm	130"	330.2 cm	130"
Number	2		2		2	
Rope Diameter	12.06 cm	4.75"	12.70 cm	5.00"	11.76 cm	4.63"
Electrical						
IGBT-AFE Inverter Cabinets	(4) or (5) water cooled		(4) or (5) water cooled		(4) or (5) water cooled	
Hoist Motors	(6) to (8) x 1230 kW	(6) to (8) x 1650 applied hp	(6) to (8) x 1230 kW	(6) to (8) x 1650 applied hp	(6) to (8) x 1230 kW	(6) to (8) x 1650 applied hp
Drag Motors	(6) to (8) x 1230 kW	(6) to (8) x 1650 applied hp	(6) to (8) x 1230 kW	(6) to (8) x 1650 applied hp	(6) to (8) x 1230 kW	(6) to (8) x 1650 applied hp
Swing Motors	(8) to (10) x 932 kW	(8) to (10) x 1250 applied hp	(8) to (10) x 932 kW	(8) to (10) x 1250 applied hp	(8) to (10) x 932 kW	(8) to (10) x 1250 applied hp
Walking Motors	(4) x 932 kW	(4) x 1250 applied hp	(4) x 932 kW	(4) x 1250 applied hp	(4) x 932 kW	(4) x 1250 applied hp
Base						
Outside Diameter	25.6 m	84'0"	25.6 m	84'0"	25.6 m	84'0"
Bearing Area	514.85 m ²	5542 ft ²	514.85 m ²	5542 ft ²	514.85 m ²	5542 ft ²
Bearing Pressure*	131.0-140.6 kPa	19.00-20.39 psi	131.0-140.6 kPa	19.00-20.39 psi	131.0-140.6 kPa	19.00-20.39 psi
Circle Rail Diameter	16.8 m	55'0"	16.8 m	55'0"	16.8 m	55'0"
Rollers (average diameter)	40.6 cm	16"	40.6 cm	16"	40.6 cm	16"
Swing Gear (pitch diameter)	13.87 m	45'6"	13.87 m	45'6"	13.87 m	45'6"
Walking Mounting						
Shoe Width and Length	4.9 m x 24.4 m	16'0" x 80'0"	4.9 m x 24.4 m	16'0" x 80'0"	4.9 m x 24.4 m	16'0" x 80'0"
Combined Bearing Area	237.8 m ²	2560 ft ²	237.8 m ²	2560 ft ²	237.8 m ²	2560 ft ²
Bearing Pressure (@ 80% of working weight)	226.8-243.5 kPa	32.90-35.32 psi	226.8-243.5 kPa	32.90-35.32 psi	226.8-243.5 kPa	32.90-35.32 psi
Overall Width over Shoes	37.08 m	121'8"	37.08 m	121'8"	37.08 m	121'8"
Length of Step (approximate)	2.28 m	7'6"	2.28 m	7'6"	2.28 m	7'6"
Bucket Capacity	76-116 m ³	100-152 yd ³	76-116 m ³	100-152 yd ³	76-116 m ³	100-152 yd ³

*Net weight, ballast weight, working weight, bearing pressure (kPa/psi) will vary with boom length, angle, and rated suspended load.
NOTE: Motor combinations and IGBT-AFE Inverter Cabinets vary with boom length, angle, and rated suspension load.

MODEL	8750 – 25.6 m (84'0") Base					
Boom Length	132.5 m	435'0"	132.5 m	435'0"	132.5 m	435'0"
Boom Angle	39°		35°		32°	
Rated Suspension Load	263 088 kg	580,000 lb	254 016 kg	560,000 lb	240 404 kg	530,000 lb
Weights*						
Net Weight, Domestic (approximate with bucket)	6 672 341 kg	14,710,000 lb		*		*
Working Weight (approximate with bucket)	7 202 140 kg	15,878,000 lb		*		*
Ballast Weight (approximate)	529 796 kg	1,168,000 lb		*		*
Drag Rope						
Drum Diameter	330.2 cm	130"	330.2 cm	130"	330.2 cm	130"
Number		2		2		2
Rope Diameter	11.43 cm	4.50"	11.43 cm	4.50"	11.43 cm	4.50"
Hoist Rope						
Drum Diameter	330.2 cm	130"	330.2 cm	130"	330.2 cm	130"
Number		2		2		2
Rope Diameter	11.43 cm	4.50"	11.43 cm	4.50"	11.43 cm	4.50"
Electrical						
IGBT-AFE Inverter Cabinets	(4) or (5) water cooled		(4) or (5) water cooled		(4) or (5) water cooled	
Hoist Motors	(6) to (8) x 1230 kW	(6) to (8) x 1650 applied hp	(6) to (8) x 1230 kW	(6) to (8) x 1650 applied hp	(6) to (8) x 1230 kW	(6) to (8) x 1650 applied hp
Drag Motors	(6) to (8) x 1230 kW	(6) to (8) x 1650 applied hp	(6) to (8) x 1230 kW	(6) to (8) x 1650 applied hp	(6) to (8) x 1230 kW	(6) to (8) x 1650 applied hp
Swing Motors	(8) to (10) x 932 kW	(8) to (10) x 1250 applied hp	(8) to (10) x 932 kW	(8) to (10) x 1250 applied hp	(8) to (10) x 932 kW	(8) to (10) x 1250 applied hp
Walking Motors	(4) x 932 kW	(4) x 1250 applied hp	(4) x 932 kW	(4) x 1250 applied hp	(4) x 932 kW	(4) x 1250 applied hp
Base						
Outside Diameter	25.6 m	84'0"	25.6 m	84'0"	25.6 m	84'0"
Bearing Area	514.85 m ²	5542 ft²	514.85 m ²	5542 ft²	514.85 m ²	5542 ft²
Bearing Pressure*	131.0-140.6 kPa	19.00-20.39 psi	131.0-140.6 kPa	19.00-20.39 psi	131.0-140.6 kPa	19.00-20.39 psi
Circle Rail Diameter	16.8 m	55'0"	16.8 m	55'0"	16.8 m	55'0"
Rollers (average diameter)	40.6 cm	16"	40.6 cm	16"	40.6 cm	16"
Swing Gear (pitch diameter)	13.87 m	45'6"	13.87 m	45'6"	13.87 m	45'6"
Walking Mounting						
Shoe Width and Length	4.9 m x 24.4 m	16'0" x 80'0"	4.9 m x 24.4 m	16'0" x 80'0"	4.9 m x 24.4 m	16'0" x 80'0"
Combined Bearing Area	237.8 m ²	2560 ft²	237.8 m ²	2560 ft²	237.8 m ²	2560 ft²
Bearing Pressure (@ 80% of working weight)	226.8-243.5 kPa	32.90-35.32 psi	226.8-243.5 kPa	32.90-35.32 psi	226.8-243.5 kPa	32.90-35.32 psi
Overall Width over Shoes	37.08 m	121'8"	37.08 m	121'8"	37.08 m	121'8"
Length of Step (approximate)	2.28 m	7'6"	2.28 m	7'6"	2.28 m	7'6"
Bucket Capacity	76-116 m ³	100-152 yd³	76-116 m ³	100-152 yd³	76-116 m ³	100-152 yd³

*Net weight, ballast weight, working weight, bearing pressure (kPa/psi) will vary with boom length, angle, and rated suspended load.

NOTE: Motor combinations and IGBT-AFE Inverter Cabinets vary with boom length, angle, and rated suspension load.

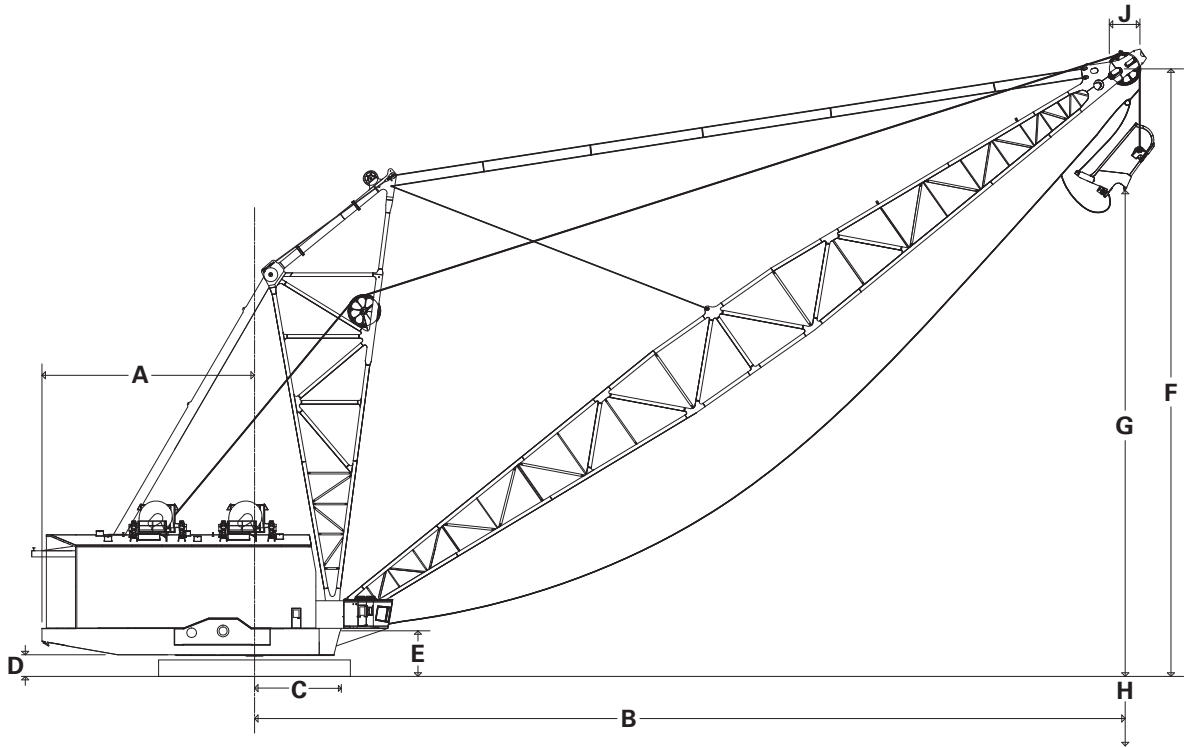

MODEL

8750 – 25.6 m (84'0") Base

	109.7 m	360'0"	109.7 m	360'0"	109.7 m	360'0"
Boom Length	109.7 m	360'0"	109.7 m	360'0"	109.7 m	360'0"
Boom Angle	39°		35°		32°	
Rated Suspension Load	344 730 kg	760,000 lb	344 730 kg	760,000 lb	322 051 kg	710,000 lb
Dimensions/Working Ranges						
A Clearance Radius	29.26 m	96'0"	29.26 m	96'0"	29.26 m	96'0"
B Operating Radius	94.5 m	310.0'	99.1 m	325.1'	102.2 m	335.5'
C Boom Foot Radius	7.3 m	24'0"	7.3 m	24'0"	7.3 m	24'0"
D Clearance Height	4.69 m	15'5"	4.69 m	15'5"	4.69 m	15'5"
E Boom Foot Height	6.5 m	21'6"	6.5 m	21'6"	6.5 m	21'6"
F Boom Point Height	75.6 m	248.0'	69.5 m	228.0'	64.7 m	212.3'
G Dumping Height	51.8 m	170'0"	45.7 m	150'0"	42.4 m	139'0"
H Digging Depth	64.3 m	211'0"	70.4 m	231'0"	73.5 m	241'0"
J Point Sheave Pitch Diameter	381 cm	150"	381 cm	150"	381 cm	150"

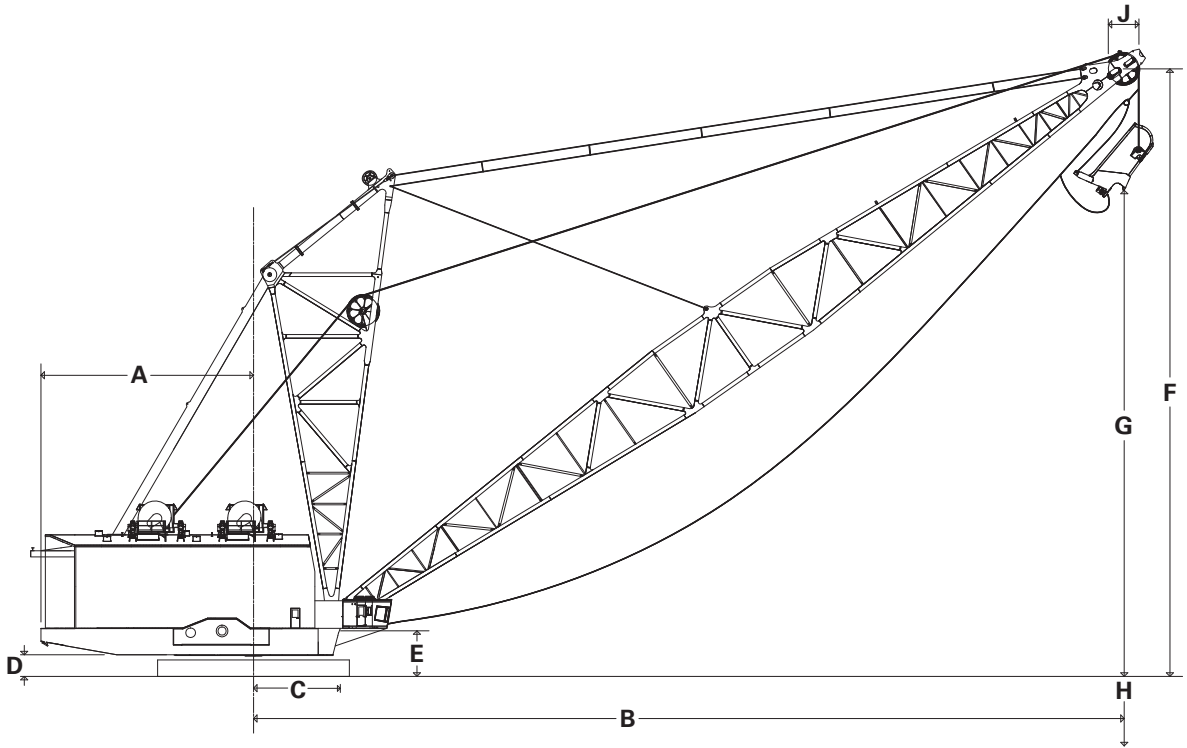

MODEL

8750 – 25.6 m (84'0") Base

	117.3 m	385'0"	117.3 m	385'0"	117.3 m	385'0"
Boom Length	117.3 m	385'0"	117.3 m	385'0"	117.3 m	385'0"
Boom Angle	39°		35°		32°	
Rated Suspension Load	344 730 kg	760,000 lb	344 730 kg	760,000 lb	283 495 kg	625,000 lb
Dimensions/Working Ranges						
A Clearance Radius	29.26 m	96'0"	29.26 m	96'0"	29.26 m	96'0"
B Operating Radius	100.4 m	329.5'	105.3 m	345.6'	109 m	356.7'
C Boom Foot Radius	7.3 m	24'0"	7.3 m	24'0"	7.3 m	24'0"
D Clearance Height	4.69 m	15'5"	4.69 m	15'5"	4.69 m	15'5"
E Boom Foot Height	6.5 m	21'6"	6.5 m	21'6"	6.5 m	21'6"
F Boom Point Height	80.4 m	263.8'	73.9 m	242.3'	68.7 m	225.5'
G Dumping Height	56.4 m	185'0"	50.0 m	164'0"	47.2 m	155'0"
H Digging Depth	59.4 m	195'0"	65.8 m	216'0"	68.9 m	226'0"
J Point Sheave Pitch Diameter	381 cm	150"	381 cm	150"	381 cm	150"

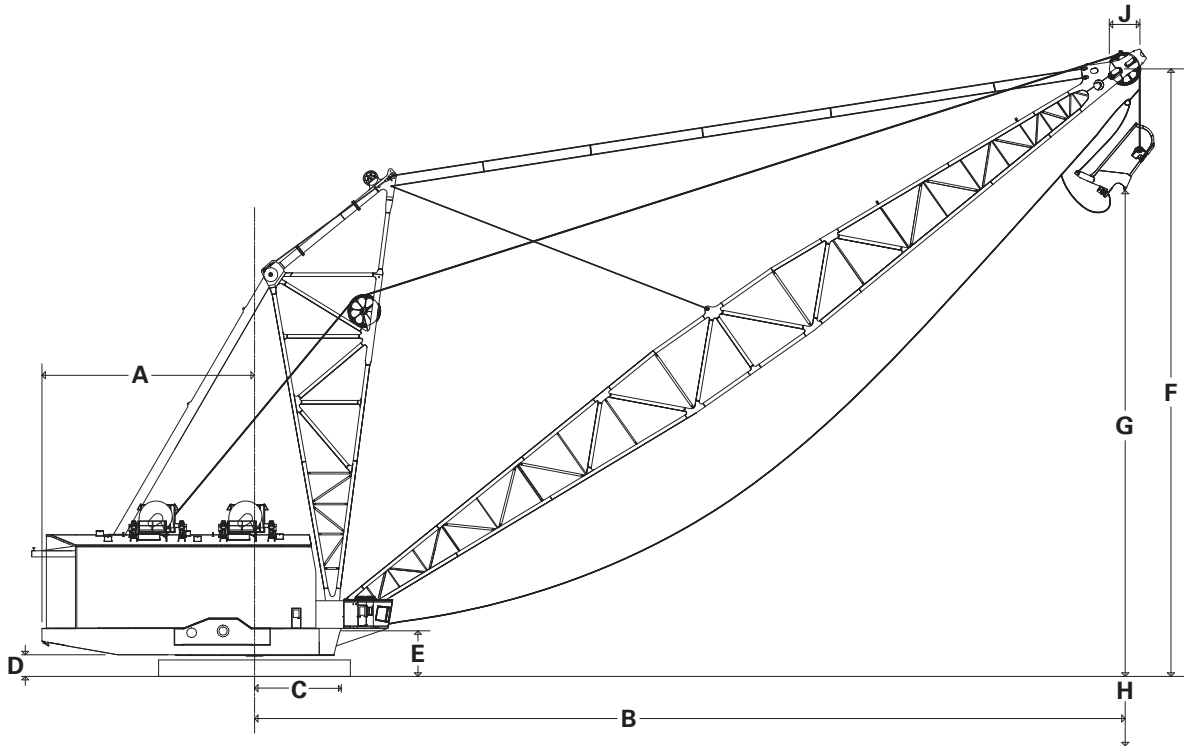

MODEL

8750 – 25.6 m (84'0") Base

	124.9 m	410'0"	124.9 m	410'0"	124.9 m	410'0"
Boom Length						
Boom Angle	39°		35°		32°	
Rated Suspension Load	306 175 kg	675,000 lb	317 515 kg	700,000 lb	272 155 kg	600,000 lb
Dimensions/Working Ranges						
A Clearance Radius	29.26 m	96'0"	29.26 m	96'0"	29.26 m	96'0"
B Operating Radius	106.3 m	348.9'	111.5 m	366.1'	115.2 m	377.9'
C Boom Foot Radius	7.3 m	24'0"	7.3 m	24'0"	7.3 m	24'0"
D Clearance Height	4.69 m	15'5"	4.69 m	15'5"	4.69 m	15'5"
E Boom Foot Height	6.5 m	21'6"	6.5 m	21'6"	6.5 m	21'6"
F Boom Point Height	85.2 m	279.5'	78.2 m	256.8'	72.8 m	238.9'
G Dumping Height	62.8 m	206'0"	55.2 m	181'0"	51.2 m	168'0"
H Digging Depth	53.0 m	174'0"	60.7 m	199'0"	64.6 m	212'0"
J Point Sheave Pitch Diameter	381 cm	150"	381 cm	150"	381 cm	150"

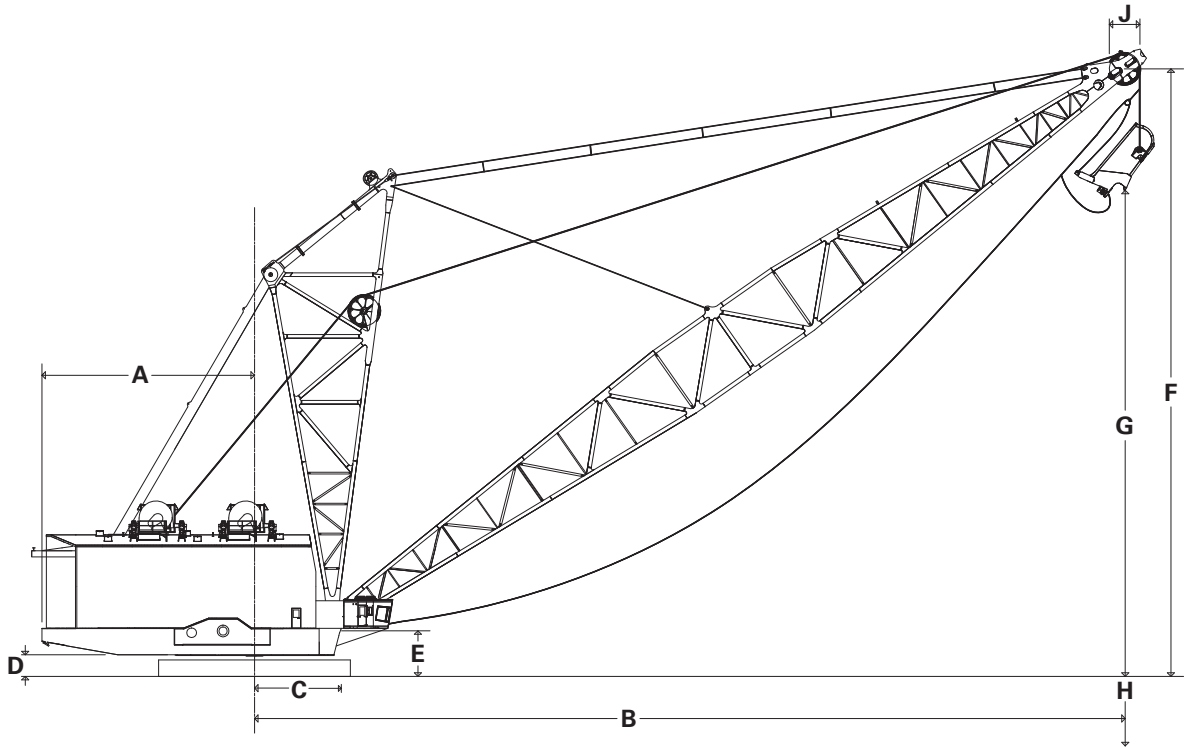

MODEL

8750 – 25.6 m (84'0") Base

	132.5 m	435'0"	132.5 m	435'0"	132.5 m	435'0"
Boom Length	132.5 m	435'0"	132.5 m	435'0"	132.5 m	435'0"
Boom Angle	39°		35°		32°	
Rated Suspension Load	263 084 kg	580,000 lb	254 012 kg	560,000 lb	240 404 kg	530,000 lb
Dimensions/Working Ranges						
A Clearance Radius	29.26 m	96'0"	29.26 m	96'0"	29.26 m	96'0"
B Operating Radius	112.3 m	368.3'	117.8 m	386.6'	121.6 m	399.2'
C Boom Foot Radius	7.3 m	24'0"	7.3 m	24'0"	7.3 m	24'0"
D Clearance Height	4.69 m	15'5"	4.69 m	15'5"	4.69 m	15'5"
E Boom Foot Height	6.5 m	21'6"	6.5 m	21'6"	6.5 m	21'6"
F Boom Point Height	90 m	295.2'	82.6 m	271.0'	76.8 m	252.0'
G Dumping Height	69.2 m	227'0"	61.9 m	203'0"	56.7 m	186'0"
H Digging Depth	46.9 m	154'0"	54.3 m	178'0"	59.1 m	194'0"
J Point Sheave Pitch Diameter	381 cm	150"	381 cm	150"	381 cm	150"

10/10/20 LOAD MANAGEMENT POLICY — DRAGLINES

“Machine overload” shall consist of operating the dragline(s) outside of the acceptable allowable load distribution.

The customer shall be responsible for the monitoring and management of all dragline operational activities, including, but not limited to, management of the machine loading such that its loaded distribution is within the acceptable allowable load distribution.

Operating outside of these parameters over any rolling 30 day period can void the customer’s standard warranty; any extended warranty; any availability guarantee and/or result in adjustments to Caterpillar’s obligations under any contract or agreement.

Loading Distribution

Loading use over any rolling 30 Day period analyzed:

- No more than 10% of loads should exceed 110% of rated payload.
- No load should exceed 120% of rated payload.
- The average of all loads for the unit must at least equal the rated payload.

KEY

- 90% of loads should fall into this range.
- No more than 10% of loads should exceed 110% of the target payload.
- No loads should be above 120% of the target payload.

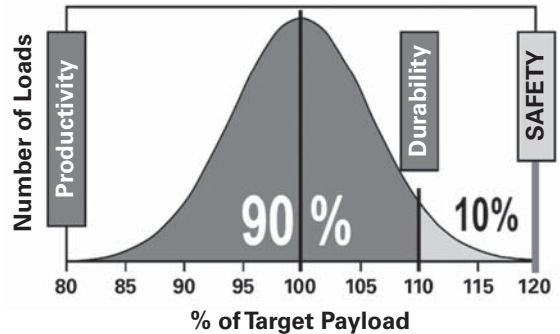

Loading use in excess of this prescribed distribution is considered “machine overload.”

Notes

- For this policy to be in effect, the “operational cycle” payload feedback must be available to the operator in order that the customer can control actual payloads.
- Customer must procure, install, and use AccessDirect™, MIDAS, and Accuload, and the data must be provided to Caterpillar unmodified and unencumbered.
- Caterpillar must be notified in a timely fashion if the payload monitoring and feedback system is out of service.

ELECTRIC ROPE SHOVELS

CONTENTS

ELECTRIC ROPE SHOVELS

Introduction	16-25
Safety and Serviceability	16-25
Features	16-25
Specifications	16-28
Digging Envelopes	16-31
General Dimensions	16-38
Ground Bearing Pressure	16-45
Dipper Selection	16-46
Truck Match	16-47
10/10/20 Load Management Policy	16-48

INTRODUCTION

Electric rope shovels are one of the largest loading tools on the market. They run in a truck-shovel operation with mining trucks in order to move large quantities of material at a low cost per ton. Electric rope shovels are used to mine a variety of minerals including oil sands, coal overburden, copper, gold, iron ore, etc. They operate at extreme climates in tough surface mining applications all over the world. With over 85 years' experience in the rope shovel industry, and an active population of nearly 250 machines, Cat Electric Rope Shovels are the most efficient and cost effective loading tools available.

SAFETY AND SERVICEABILITY

Safety plays an integral role in everything we do at Caterpillar, from our factory floors to our service centers to our clients' mine sites. Caterpillar's commitment to safety is apparent in our product designs, which undergo risk assessments and are designed to meet strict codes and regulations.

Stairways, walkways, platforms and access points are incorporated throughout Cat Electric Rope Shovels to ensure safe and convenient access for maintenance personnel. With safety and serviceability enhancing features incorporated into the operator cab, structures, surfaces and electrical equipment, among others, Cat Electric Rope Shovels were designed with safety in mind.

FEATURES

AC IGBT Electrics

With over 30 years of AC experience and over 200 operating AC machines, Bucyrus led the industry in AC electric rope shovels. Caterpillar continues to carry on this proud tradition. Since its launch in 1981, the AC electric rope shovel has gained strong industry acceptance, offering:

- **Superior availability:** AC IGBT electric rope shovels have routinely demonstrated electrical availabilities of greater than 98%.
- **Greater reliability:** Fewer components including interchangeable inverters. IGBT systems require no fuses or circuit breakers.
- **Reduced maintenance:** No regular maintenance is required on IGBT power control modules. Motor maintenance on AC machines is reduced to greasing and replacing bearings every 30,000 hours.
- **Reduced inventory:** Cat IGBT is a mine quality system with rugged welded cabinets to withstand harsh mining conditions.

Major Structures

Cat major structures are designed for extended performance in harsh mining conditions. Structures are manufactured using cold-weather, impact-resistant, high-strength steel with select welds of full-penetration, profiled and ground type. All structural welds undergo visual inspection, with critical welds also receiving MT, UT or X-ray inspection. Large furnaces are used to stress-relieve entire weldments for reduced susceptibility to cracking. Interiors of finished structures are painted white to facilitate field inspection.

Robust Front End Design

The Cat free-floating tubular handle design presents many benefits over traditional rack-and-pinions systems, including:

- **Fast swing times:** The Cat deck-mounted, rather than boom-mounted, crowd machinery greatly reduces front end weight for reduced swing inertia and fast swing times.
- **Elimination of torsional loading:** The free-floating handle design allows the Cat handle to rotate under torsional stress, transferring stress into the ropes rather than into the boom.
- **Improved line of sight:** Cat machines provide operators with a much-improved left-hand line of sight by moving around the crowd machinery from the boom to the deck.
- **Efficient digging:** Wide-set boom point sheaves stabilize the dipper as it engages the bank for easier and more efficient digging.

Cat Cab

Caterpillar's state-of-the-art operator's cab is the product of a multi-year collaboration between Caterpillar, mining companies and shovel operators. The cab provides industry-leading visibility with excellent line of sight supplemented by five optimally-mounted cameras and display screens. It provides enhanced safety through dual access/egress doors and an optimally-placed trainer seat with independent emergency stop. Additionally, the cab offers the smoothest, most comfortable ride available with an ergonomic, adjustable operator's seat with a fully pneumatic suspension system, low-effort joysticks and dual display screens optimized for operator comfort.

Power Demand Management System

Caterpillar's exclusive Power Demand Management System for 7495 Series machines allow an electric rope shovel to operate efficiently in spite of electrical infrastructure challenges. This patented energy storage and power management technology reduces the number of generators required to run an electric rope shovel, giving mines the option of production without grid power. Additionally, this technology lowers the machine's peak power requirement, resulting in more alternatives when mines plan for power.

HydraCrowd™

HydraCrowd represents the first new crowd technology developed in the past 70 years. A hydraulic cylinder inside the tubular dipper handle maintains all the benefits of the Cat front end while eliminating the need for routine crowd/retract rope replacements. HydraCrowd cuts downtime by reducing the number of maintenance events needed to keep the machine operational. HydraCrowd is controlled with proven Cat IGBT technology and has complete diagnostic and troubleshooting information with step-by-step instructions. This technology is currently under a controlled release.

LatchFree™

The LatchFree Dipper System is Caterpillar's solution to customers' number one cause of downtime — the latch assembly. The LatchFree dipper eliminates the latch assembly, replacing it with a strong steel link mounted to the dipper back, away from material flow. The system enhances safety by reducing the number of maintenance events required to maintain the system and increase reliability by reducing unplanned downtime. The LatchFree Dipper System comes complete with a comprehensive training program to ensure customers achieve maximum system benefits, and is currently under a controlled release.

FastFil™ Dipper Design

The unique FastFil dipper provides customers with faster and fuller dipper loads where the application permits. Its trapezoidal shape accommodates the natural configuration of the load, eliminating voids that occur with box-shaped dippers for improved fill factors. The trapezoidal shape also reduces dipper size and weight for improved maneuverability and faster swing times. Additionally, optimized lip and rake angles lead to improved bank penetration and eliminate bulldozing for reduced material turbulence. Finally, a shorter dipper body cuts load and dump time. Combined, FastFil features optimize fill factor.

AccessDirect

AccessDirect is an electrical interface system that facilitates remote access to a machine's onboard computer via the Internet. With AccessDirect, maintenance personnel can analyze faults from off-site locations and arrive on-site prepared to resolve the issues, leading to reduced machine downtime. AccessDirect also enables factory experts to remote-access and troubleshoot faults, resulting in superior response times and reduced mean time to repair.

MIDAS

The MIDAS health monitoring system continues to optimize machine performance by providing, logging and analyzing data on a variety of machine variables. MIDAS comes complete with a built-in report generator that outputs data in a format that can be easily analyzed to identify opportunities to improve machine performance. When paired with AccessDirect, MIDAS provides real-time monitoring of shovel operation and provides users with a 3D model to watch the shovel in motion.

AccuLoad

AccuLoad is a data analysis system that provides real-time feedback on dipper loads. AccuLoad's load calculation is accomplished without mechanical sensors, eliminating the need for recalibration a common problem with other load weighing systems. The system can be employed to calculate material moved, to monitor overloading of trucks or to allow operators to study their load and shift performance. It can also log operator performance data which, when paired with MIDAS, can generate reports to help identify training opportunities to increase shift production.

MODEL	7295		7395	
Payload	45 tonnes	50 tons	64 tonnes	70 tons
Operating Weight	793 259 kg*	1,748,837 lb*	1 202 927 kg**	2,652,000 lb**
Dipper Range	19.1-38.2 m ³	25-50 yd³	20.5-55.8 m ³	27-73 yd³
Drive	AC IGBT		AC IGBT	
Distribution System Requirements (separate system)	2000 kVA		3500 kVA	
Distribution System Requirements (large system)	1320 kVA		2000 kVA	
Average 15 Minute Demand	538-753 kW		777-1087 kW	
Peak Power	2152 kW		3106 kW	
Crowd Type	Tubular handle rope crowd		Tubular handle rope crowd	
Hoist Ropes				
Number	2		2	
Diameter	57 mm	2¼"	70 mm	2¾"
Type	Twin dual		Twin dual	
Construction	8 strand		8 strand	
Crowd/Retract Ropes				
Number	1 crowd, 1 retract		1 crowd, 1 retract	
Diameter	60 mm	2¾"	64 mm	2½"
Type	Single dual		Single dual	
Construction	8 strand		8 strand	

*Based on a 19 m³ (**25 yd³**) dipper.

Based on a 24 m³ (32 yd³**) dipper.

Information subject to change.

MODEL	7495 HD		7495		7495 HydraCrowd	
Payload	82 tonnes	90 tons	109 tonnes	120 tons	109 tonnes	120 tons
Operating Weight	1 295 777 kg*	2,856,700 lb*	1 386 178 kg**	3,056,000 lb**	1 390 714 kg***	3,066,000 lb***
Dipper Range	27.5-60.4 m ³	36-79 yd³	30.6-62.7 m ³	40-82 yd³	30.6-62.7 m ³	40-82 yd³
Drive	AC IGBT		AC IGBT		AC IGBT	
Distribution System Requirements (separate system)	3500 kVA		4000 kVA		4000 kVA	
Distribution System Requirements (large system)	2000 kVA		2080 kVA		2120 kVA	
Average 15 Minute Demand	832-1165 kW		934-1308 kW		945-1322 kW	
Peak Power	3330 kW		3737 kW		3778 kW	
Crowd Type	Tubular handle rope crowd		Tubular handle rope crowd		Tubular handle HydraCrowd	
Hoist Ropes	2		2		2	
Number	2		2		2	
Diameter	70 mm	2¾"	70 mm	2¾"	70 mm	2¾"
Type	Twin dual		Twin dual		Twin dual	
Construction	8 strand		8 strand		8 strand	
Crowd/Retract Ropes	1 crowd, 1 retract		1 crowd, 1 retract		N/A	
Number	1 crowd, 1 retract		1 crowd, 1 retract		N/A	
Diameter	64 mm	2.5"	64 mm	2.5"	N/A	
Type	Single dual		Single dual		N/A	
Construction	8 strand		8 strand		N/A	

*Based on 32 m³ (**42 yd³**) dipper.

Based on 55.8 m³ (73 yd³**) dipper.

***Based on 45.1 m³ (**59 yd³**) LatchFree dipper.

N/A = Not Available.

Information subject to change.

MODEL	7495 HF		7495 HF HydraCrowd	
Payload	109 tonnes	120 tons	109 tonnes	120 tons
Operating Weight	1 431 064 kg*	3,155,000 lb*	1 435 166 kg**	3,164,000 lb**
Dipper Range	30.6-62.7 m ³	40-82 yd³	30.6-62.7 m ³	40-82 yd³
Drive	AC IGBT		AC IGBT	
Distribution System Requirements (separate system)	4000 kVA		4000 kVA	
Distribution System Requirements (large system)	2080 kVA		2120 kVA	
Average 15 Minute Demand	934-1308 kW		945-1322 kW	
Peak Power	3737 kW		3778 kW	
Crowd Type	Tubular handle rope crowd		Tubular handle HydraCrowd	
Hoist Ropes				
Number	2		2	
Diameter	70 mm	2¾"	70 mm	2¾"
Type	Twin dual		Twin dual	
Construction	8 strand		8 strand	
Crowd/Retract Ropes				
Number	1 crowd, 1 retract		N/A	
Diameter	64 mm	2½"	N/A	
Type	Single dual		N/A	
Construction	8 strand		N/A	

*Based on 55.8 m³ (**73 yd³**) dipper.

Based on 45.1 m³ (59 yd³**) LatchFree dipper.

N/A = Not Available.

Information subject to change.

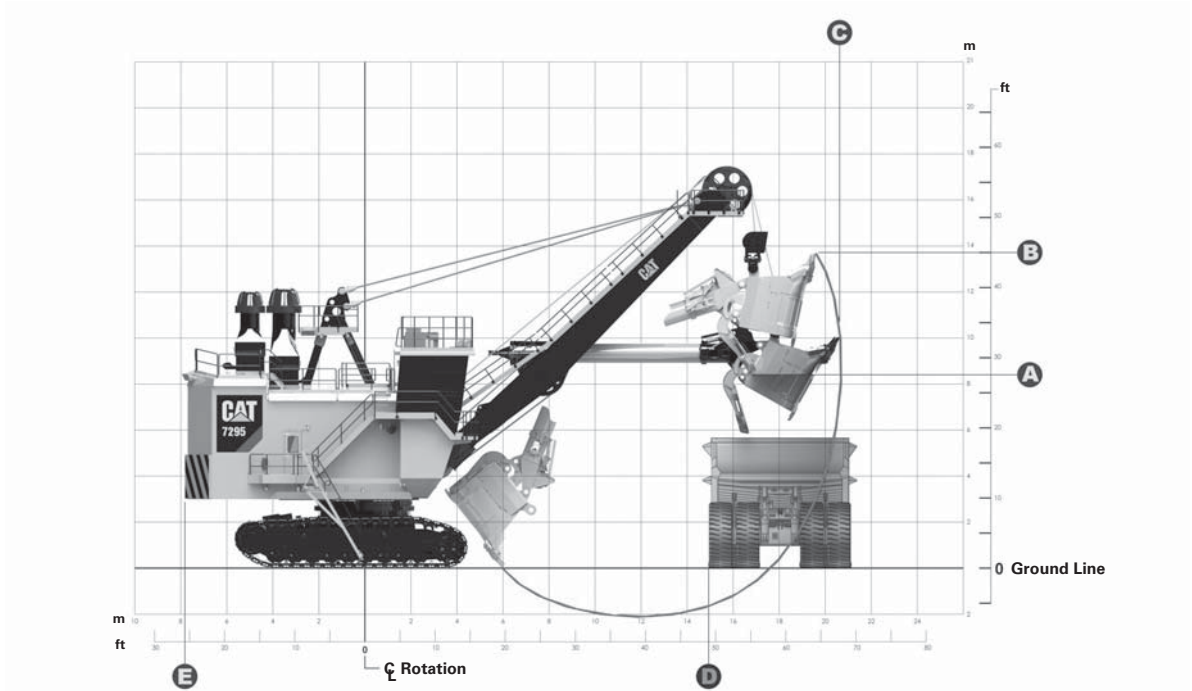

MODEL

7295

Dumping Height with Clearance to Open Dipper Door	8.40 m	27'8"
Cutting Height (maximum)	13.70 m	45'0"
Cutting Radius (maximum)	20.60 m	67'8"
Revolving Frame Tail Swing Radius	7.80 m	25'8"

Based on 19 m³ (25 yd³) dipper.

Information subject to change.

All dimensions are approximate and will vary depending on dipper size.

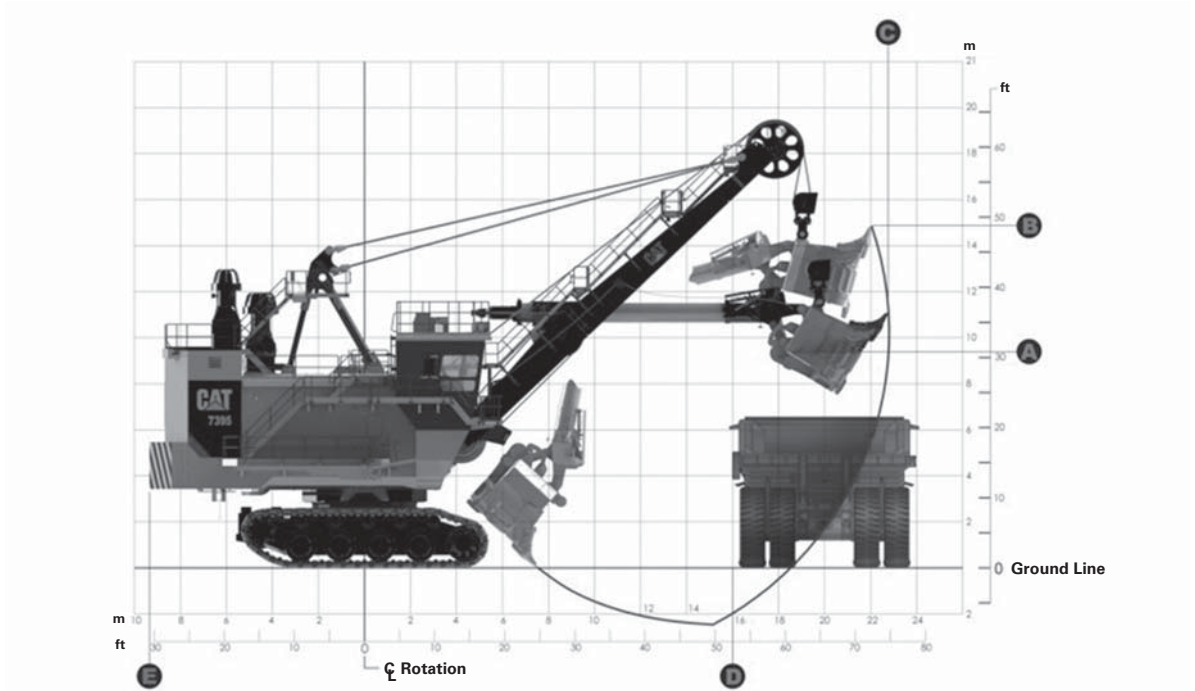

MODEL

7395

Dumping Height with Clearance to Open Dipper Door	9.40 m	30'10"
Cutting Height (maximum)	14.90 m	48'9"
Cutting Radius (maximum)	22.80 m	74'9"
Revolving Frame Tail Swing Radius	9.30 m	30'8"

Based on 24 m³ (32 yd³) dipper.
Information subject to change.

All dimensions are approximate and will vary depending on dipper size.

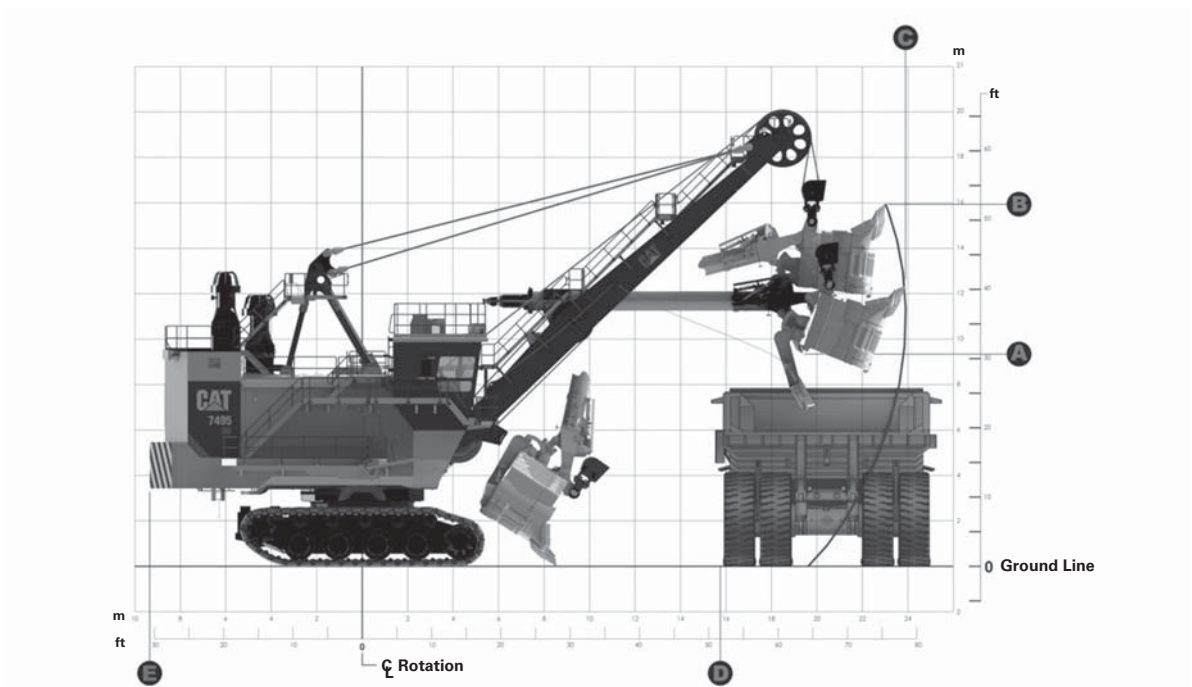

MODEL

7495 HD

Dumping Height with Clearance to Open Dipper Door	9.40 m	30'9"
Cutting Height (maximum)	16.00 m	52'4"
Cutting Radius (maximum)	23.90 m	78'5"
Revolving Frame Tail Swing Radius	9.30 m	30'8"

Based on 32 m³ (42 yd³) dipper.

Information subject to change.

All dimensions are approximate and will vary depending on dipper size.

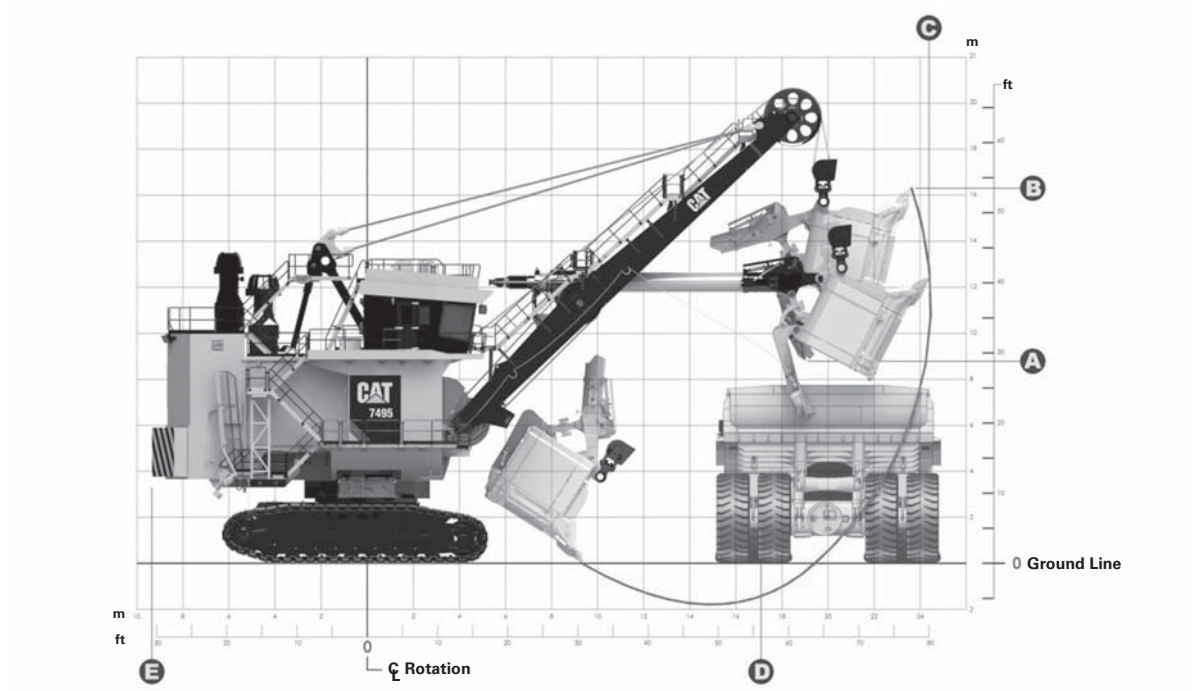

MODEL

7495

Dumping Height with Clearance to Open Dipper Door	8.80 m	28'11"
Cutting Height (maximum)	16.30 m	53'6"
Cutting Radius (maximum)	24.40 m	80'0"
Revolving Frame Tail Swing Radius	9.30 m	30'8"

Based on 56 m³ (73 yd³) dipper.

Information subject to change.

All dimensions are approximate and will vary depending on dipper size.

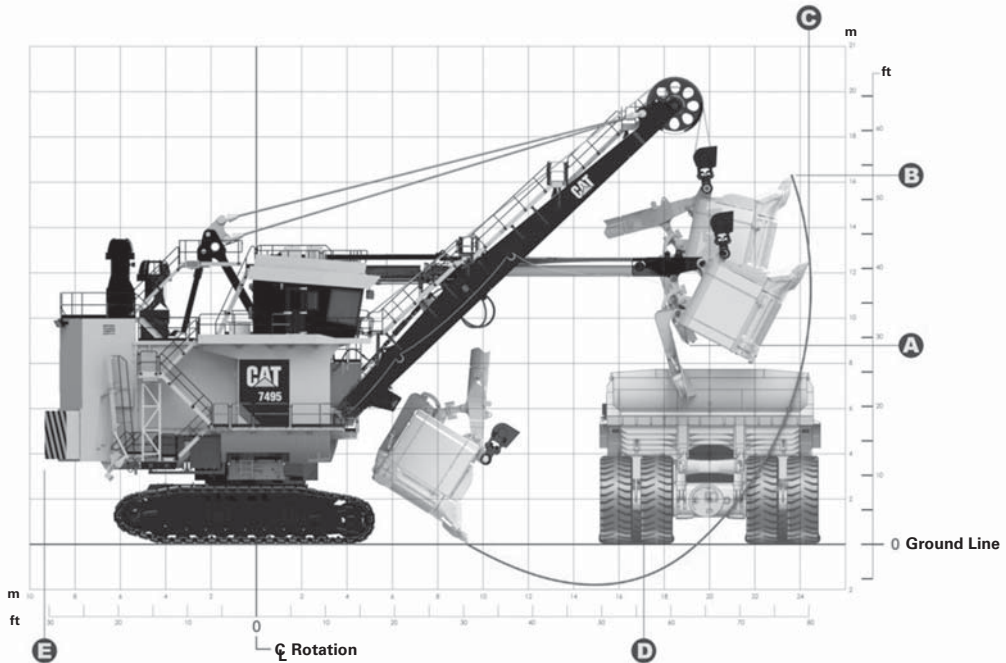

MODEL

7495 HydraCrowd

Dumping Height with Clearance to Open Dipper Door	8.80 m	28'11"
Cutting Height (maximum)	16.30 m	53'6"
Cutting Radius (maximum)	24.40 m	80'0"
Revolving Frame Tail Swing Radius	9.30 m	30'8"

Based on 56 m³ (73 yd³) dipper.

Information subject to change.

All dimensions are approximate and will vary depending on dipper size.

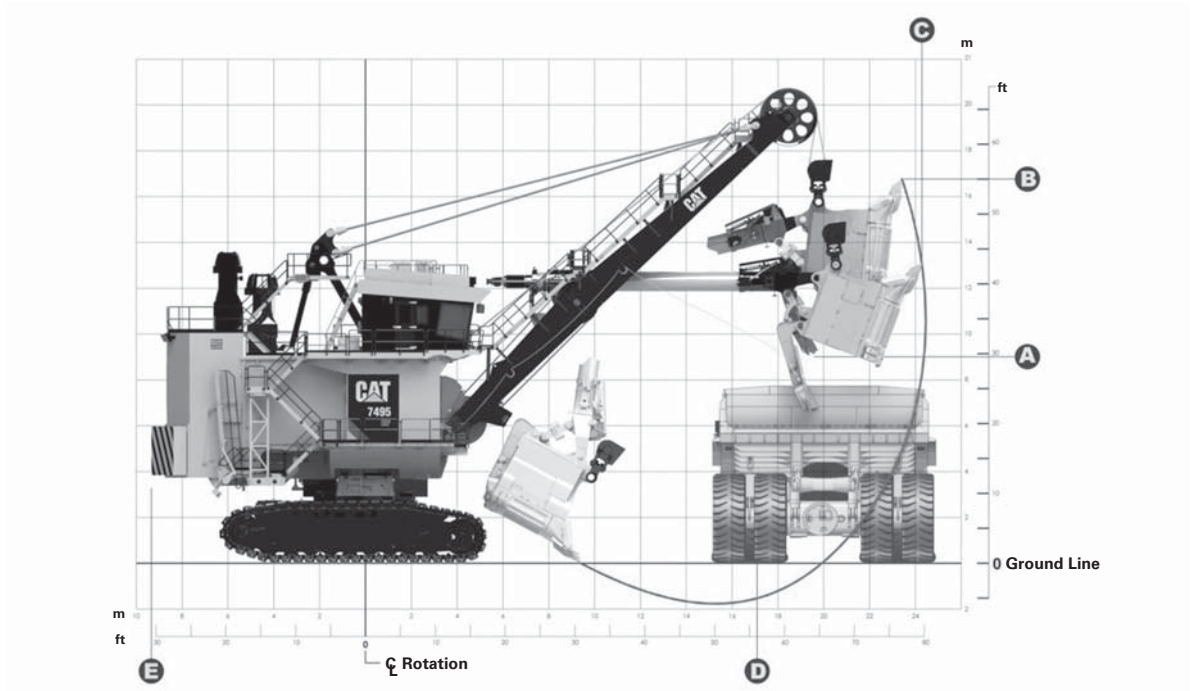

MODEL

7495 HF

Dumping Height with Clearance to Open Dipper Door	9.00 m	29'8"
Cutting Height (maximum)	16.80 m	55'0"
Cutting Radius (maximum)	24.30 m	79'8"
Revolving Frame Tail Swing Radius	9.30 m	30'8"

Based on 45 m³ (59 yd³) dipper.

Information subject to change.

All dimensions are approximate and will vary depending on dipper size.

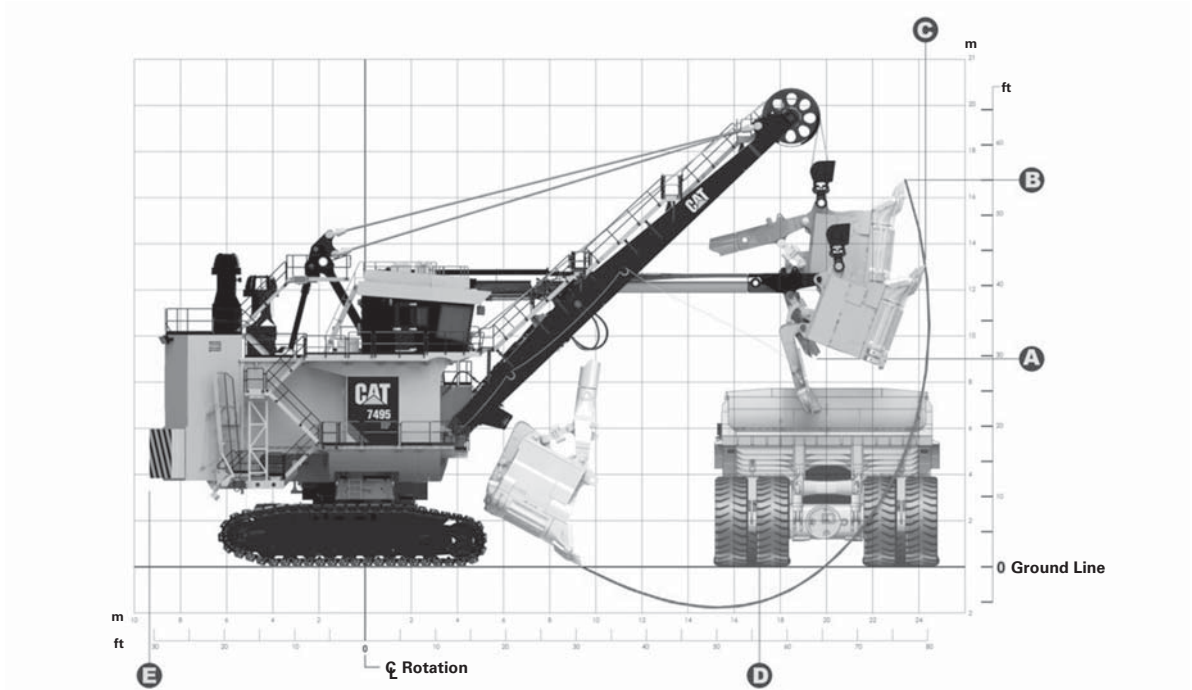

MODEL

7495 HF HydraCrowd

Dumping Height with Clearance to Open Dipper Door	9.00 m	29'8"
Cutting Height (maximum)	16.80 m	55'0"
Cutting Radius (maximum)	24.30 m	79'8"
Revolving Frame Tail Swing Radius	9.30 m	30'8"

Based on 45 m³ (59 yd³) dipper.

Information subject to change.

All dimensions are approximate and will vary depending on dipper size.

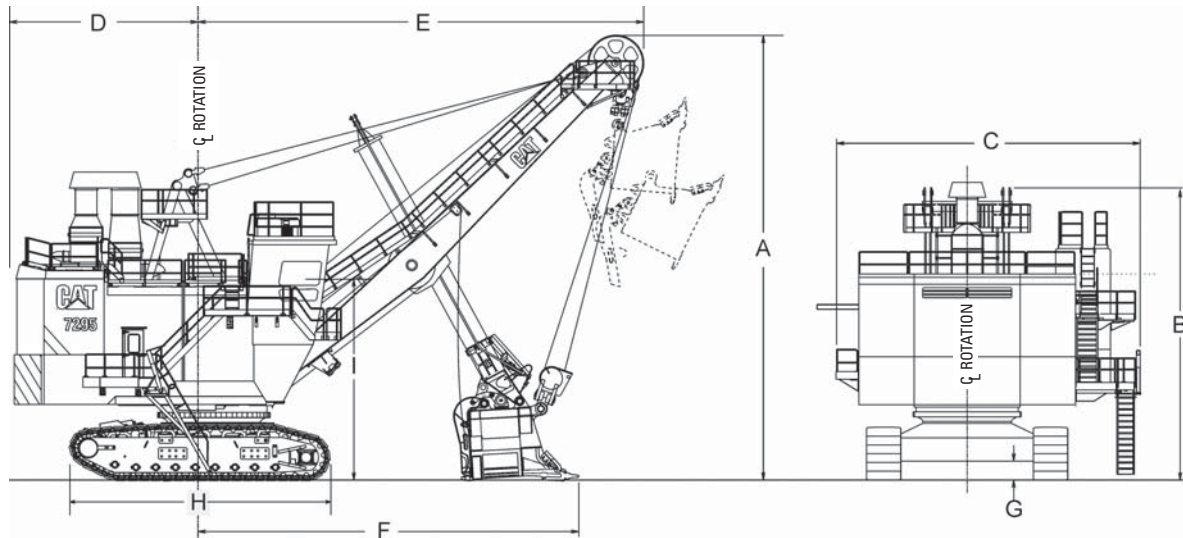

MODEL

7295

MODEL	7295	
Boom Length	18.00 m	59'0"
A Height	18.15 m	59'7"
B A-Frame Height	11.94 m	39'2"
C Overall Width	12.39 m	40'8"
D Tail Swing Radius	7.80 m	25'8"
E Clearance Radius	17.48 m	57'4"
F Radius of Level Floor	15.58 m	51'1"
G Minimum Ground Clearance	0.78 m	2'6"
H Track Length	10.26 m	33'8"
I Operator Eye Level	8.20 m	26'11"

Information subject to change.
All dimensions are approximate and will vary depending on dipper size.

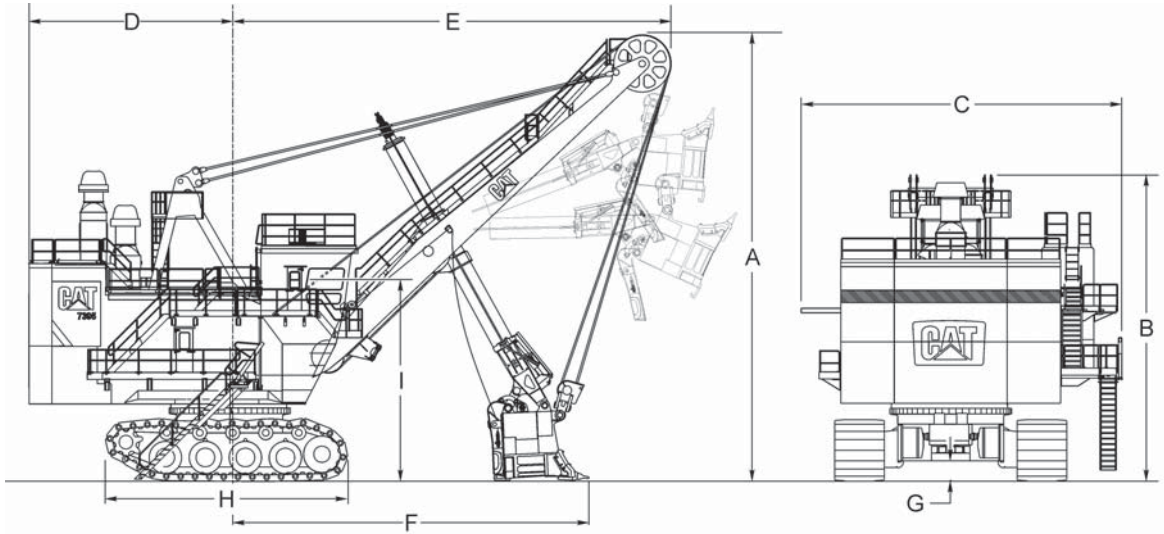

MODEL

7395

MODEL	7395	
Boom Length	19.51 m	64'0"
A Height	19.50 m	63'11"
B A-Frame Height	13.30 m	43'8"
C Overall Width	13.01 m	42'8"
D Tail Swing Radius	9.30 m	30'8"
E Clearance Radius	19.05 m	62'6"
F Radius of Level Floor	15.40 m	50'6"
G Minimum Ground Clearance	0.86 m	2'10"
H Track Length	10.41 m	34'2"
I Operator Eye Level	8.64 m	28'4"

Information subject to change.
All dimensions are approximate and will vary depending on dipper size.

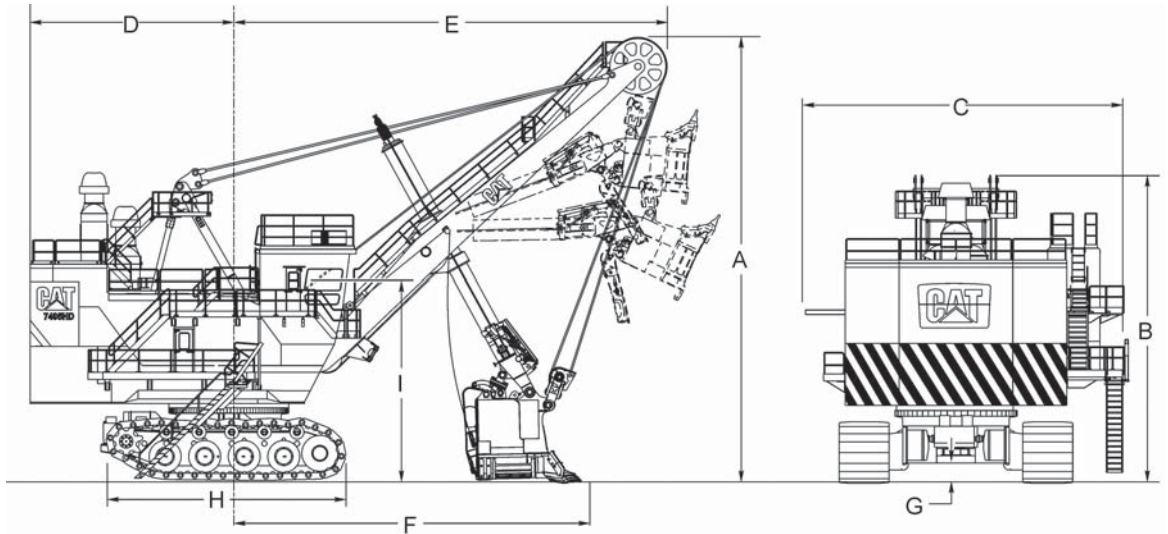

MODEL

7495 HD

MODEL	7495 HD	
Boom Length	20.40 m	67'0"
A Height	20.10 m	65'10"
B A-Frame Height	13.30 m	43'8"
C Overall Width	13.01 m	42'8"
D Tail Swing Radius	9.30 m	30'8"
E Clearance Radius	19.74 m	64'9"
F Radius of Level Floor	16.92 m	55'6"
G Minimum Ground Clearance	0.86 m	2'10"
H Track Length	10.41 m	34'2"
I Operator Eye Level	8.64 m	28'4"

Information subject to change.
All dimensions are approximate and will vary depending on dipper size.

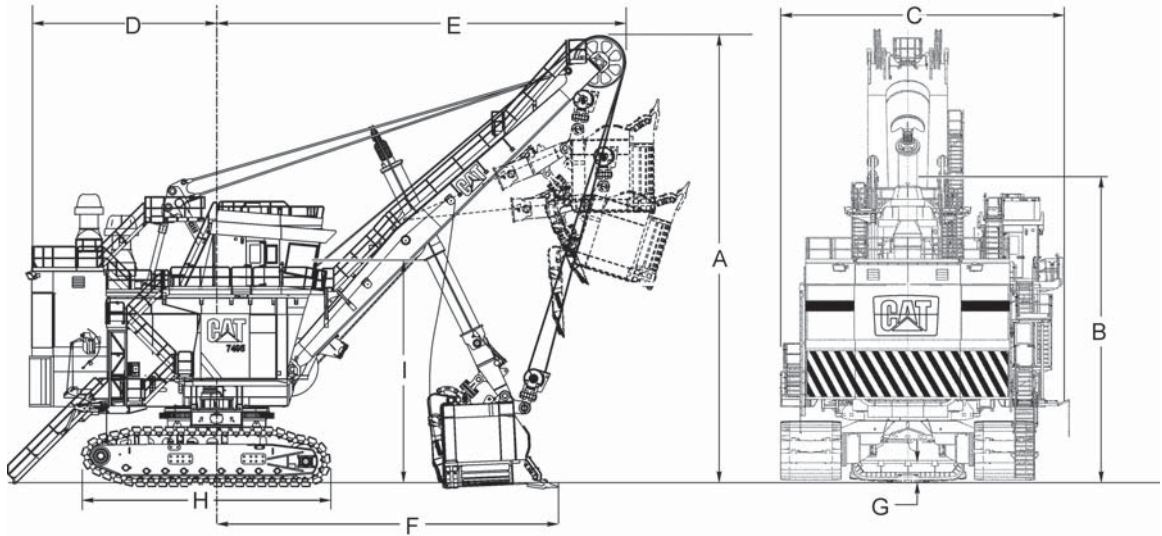

MODEL

7495

MODEL	7495	
Boom Length	20.40 m	67'0"
A Height	20.87 m	68'6"
B A-Frame Height	14.00 m	46'0"
C Overall Width	13.11 m	43'0"
D Tail Swing Radius	9.30 m	30'8"
E Clearance Radius	19.65 m	64'5"
F Radius of Level Floor	17.47 m	57'4"
G Minimum Ground Clearance	0.90 m	3'0"
H Track Length	11.43 m	37'6"
I Operator Eye Level	10.52 m	34'6"

Information subject to change.
All dimensions are approximate and will vary depending on dipper size.

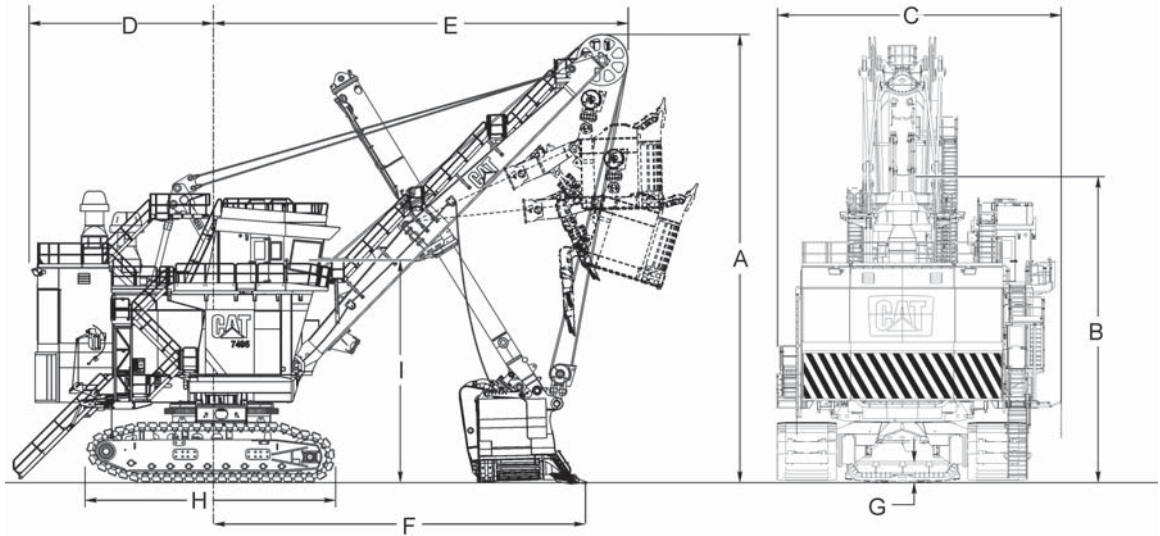

MODEL

7495 HydraCrowd

MODEL	7495 HydraCrowd	
Boom Length	20.40 m	67'0"
A Height	20.87 m	68'6"
B A-Frame Height	14.00 m	46'0"
C Overall Width	13.11 m	43'0"
D Tail Swing Radius	9.30 m	30'8"
E Clearance Radius	19.65 m	64'5"
F Radius of Level Floor	17.47 m	57'4"
G Minimum Ground Clearance	0.90 m	3'0"
H Track Length	11.43 m	37'6"
I Operator Eye Level	10.52 m	34'6"

Information subject to change.
All dimensions are approximate and will vary depending on dipper size.

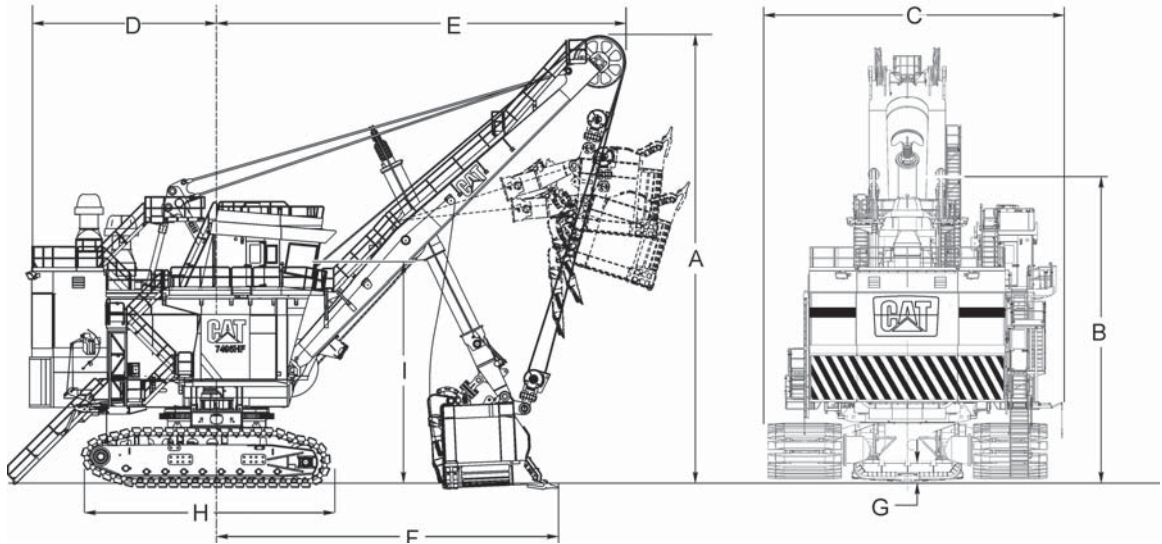

MODEL

7495 HF

Boom Length	20.40 m	67'0"
A Height	20.87 m	68'6"
B A-Frame Height	14.00 m	46'0"
C Overall Width	13.96 m	46'1"
D Tail Swing Radius	9.30 m	30'8"
E Clearance Radius	19.65 m	64'5"
F Radius of Level Floor	17.47 m	57'4"
G Minimum Ground Clearance	0.90 m	3'0"
H Track Length	11.43 m	37'6"
I Operator Eye Level	10.52 m	34'6"

Information subject to change.
All dimensions are approximate and will vary depending on dipper size.

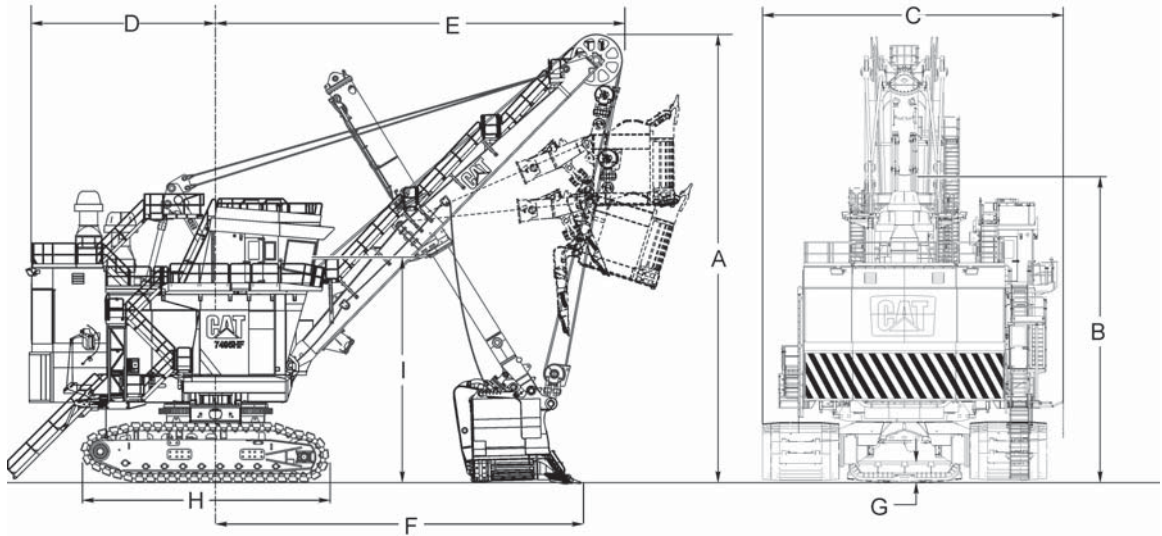

MODEL

7495 HF HydraCrowd

MODEL	7495 HF HydraCrowd	
Boom Length	20.40 m	67'0"
A Height	20.87 m	68'6"
B A-Frame Height	14.00 m	46'0"
C Overall Width	13.96 m	46'1"
D Tail Swing Radius	9.30 m	30'8"
E Clearance Radius	19.65 m	64'5"
F Radius of Level Floor	17.47 m	57'4"
G Minimum Ground Clearance	0.90 m	3'0"
H Track Length	11.43 m	37'6"
I Operator Eye Level	10.52 m	34'6"

Information subject to change.
All dimensions are approximate and will vary depending on dipper size.

GROUND BEARING PRESSURE

Ground bearing pressure, or the amount of weight that can be supported by ground conditions, determines the link width (and occasionally the machine model) that can be used at a mine site. Softer ground conditions require wider links while the softest conditions (i.e. oil sands) require a specific model (7495 HF) which was designed to operate under low ground bearing pressure

conditions. Selecting links that require higher ground bearing pressure than what exists at site will make propelling the machine difficult. A link too narrow for the application may even cause the crawlers to sink into the ground.

The chart below lists the link length options for each electric rope shovel model as well as the corresponding minimum ground bearing pressures.

MODEL	7295¹		7395²		7495 HD³		7495⁴	
Standard Link Length	183 cm	72"	213 cm	84"	213 cm	84"	200 cm	79"
Ground Bearing Pressure	269 kPa	39 psi	371 kPa	54 psi	400 kPa	58 psi	380 kPa	55 psi
Optional Link Length	—		274 cm	108"	274 cm	108"	259 cm	102"
Ground Bearing Pressure	—		276 kPa	43 psi	316 kPa	46 psi	297 kPa	43 psi

MODEL	7495 HydraCrowd⁴		7495 HF⁵		7495 HF HydraCrowd⁵	
Standard Link Length	200 cm	79"	318 cm	125"	318 cm	125"
Ground Bearing Pressure	382 kPa	55 psi	248 kPa	36 psi	248 kPa	36 psi
Optional Link Length	259 cm	102"	—		—	
Ground Bearing Pressure	293 kPa	43 psi	—		—	

¹ Based on 19 m³ (25 yd³) dipper.

² Based on 24 m³ (32 yd³) dipper.

³ Based on 32 m³ (42 yd³) dipper.

⁴ Based on 56 m³ (73 yd³) dipper.

⁵ Based on 45 m³ (59 yd³) dipper.

Information subject to change.

All dimensions are approximate.

DIPPER SELECTION

Selecting the correct dipper size plays an integral role in maximizing productivity from a truck shovel operation. Optimal dipper size is a function of truck size, material loose density, and fill factor.

The first step in calculating dipper size is to determine the machine’s optimal payload based on truck size. To calculate this, divide truck payload by three and four (three or four pass even loading is ideal for high productivity). Compare these values to the machine’s maximum payload. The machine’s optimal payload is the largest value that is less than the maximum payload.

For example, consider a mine operating a 7495 shovel (maximum payload = 120 tons) and 797 trucks (payload = 400 tons). $400 \div 3 = 133.3$ and $400 \div 4 = 100$. 133.3 can be eliminated as it is greater than the shovel’s maximum payload (120 tons). 100 tons is the largest value less than the machine’s maximum payload, and therefore, is the machine’s optimal payload.

Once optimal machine payload is determined, material loose density and fill factor are used to calculate the optimum dipper size. To calculate material loose

density, divide insitu (undisturbed material density) by 1 + swell factor.

$$\text{Material loose density} = \frac{\text{Insitu}}{(1 + \text{swell factor})}$$

Once material loose density is calculated, use the equation below to find the optimal dipper size.

$$\text{Optimal dipper size} = \frac{\text{Optimal machine payload}}{\text{Material loose density}} \times \text{Fill factor}$$

For example: For a mine with the following conditions:

Insitu: 2.276 ton/yd³

Swell factor: 35%

Fill factor: 95%

Optimal machine payload: 100 tons

$$\text{Optimal dipper size} = \frac{100 \text{ tons}}{2.276 \div (1 + 0.35)} \times .95 = 62.5 \text{ yd}^3$$

MODEL	7295		7395		7495 HD		7495	
Dipper Range	19.1- 38.2 m ³	25- 50 yd³	20.6- 55.8 m ³	27- 73 yd³	27.5- 60.4 m ³	36- 79 yd³	30.6- 62.7 m ³	40- 82 yd³

MODEL	7495 HydraCrowd		7495 HF		7495 HF HydraCrowd	
Dipper Range	30.6-62.7 m ³	40-82 yd³	30.6-62.7 m ³	40-82 yd³	30.6-62.7 m ³	40-82 yd³

Information subject to change.

TRUCK MATCH

Truck shovel match, or the number of passes necessary to load a truck, has a major impact on an operation's productivity. To optimize productivity, 3 to 4 even pass loading of trucks is ideal. The chart below shows pass match between Cat electric rope shovels and Cat trucks.

MODEL	Payload	7295	7395	7495 HD	7495	7495 HF
	tonne (ton)	45 (50)	64 (70)	82 (90)	109* (120*)	109* (120*)
785D	136 (150)	3				
789D	181 (200)	4	3			
MT4400D AC	221 (244)		4	3		
793F	227 (250)		4	3		
MT5300D AC	291 (320)			4	3	3
795F AC	313 (345)			4	3	3
797F	363 (400)				4	4

*Indicates maximum payload.

**10/10/20 LOAD MANAGEMENT POLICY —
ELECTRIC ROPE SHOVELS**

“Machine overload” shall consist of operating the shovel(s) outside of the acceptable allowable load distribution.

The customer shall be responsible for the monitoring and management of all shovel operational activities, including, but not limited to, management of the machine loading such that its loaded distribution is within the acceptable allowable load distribution.

Operating outside of these parameters over any rolling 30 day period can void the customer’s standard warranty; any extended warranty; any availability guarantee and/or result in adjustments to Caterpillar’s obligations under any contract or agreement.

Loading Distribution

Loading use over any rolling 30 Day period analyzed:

- No more than 10% of loads should exceed 110% of rated payload.
- No load should exceed 120% of rated payload.
- The average of all loads for the unit not to exceed the rated payload.

KEY

- 90% of loads should fall into this range.
- No more than 10% of loads should exceed 110% of the target payload.
- No loads should be above 120% of the target payload.

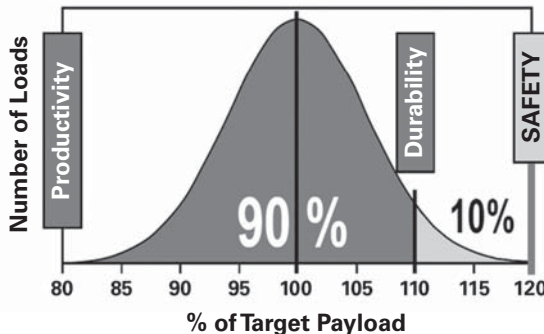

Loading use in excess of this prescribed distribution is considered “machine overload.”

Notes

- For this policy to be in effect, the “operational cycle” payload feedback must be available to the operator in order that the customer can control actual payloads.
- Customer must procure, install, and use AccessDirect, MIDAS, and Accuload, and the data must be provided to Caterpillar unmodified and unencumbered.
- Caterpillar must be notified in a timely fashion if the payload monitoring and feedback system is out of service.

HYDRAULIC MINING SHOVELS

CONTENTS

HYDRAULIC MINING SHOVELS

General Introduction	16-49
Features	16-50
Specifications	16-51
Digging Envelopes/Working Range/ Digging Forces	16-61
General Dimensions	16-76
Ground Pressures	16-81
Bucket Selection	16-84
Cycle Times	16-85
Production Overviews	16-87

GENERAL INTRODUCTION

Hydraulic Mining Shovels

Hydraulic mining shovels are designed to move large volumes of materials, and the majority are employed in the mining industry for loading large Mining and Off-Highway Trucks. Key design characteristics are high digging forces and quick working cycles for best performance, and a durable design to handle severe working conditions. Hydraulic mining shovels dig and load various commodities, such as gold, copper, iron ore, diamonds and coal, or they remove overburden, in any climatic condition around the world. Typically operated around the clock, Hydraulic Mining Shovels accumulate up to 6500 hours per year.

Nomenclature

The 6000 Series constitutes the Cat hydraulic mining shovel product line. The name of each individual model gives a direct reference to the size of the machine and consists of a four-digit number, plus additional capital letters in specific cases, depending on the particular drive system and attachment configuration.

The first digit designates the 6000 Series and is followed by another three digits indicating the approximate bucket payload of that model in metric tonnes. Without any extra letters, the specific model is a diesel driven hydraulic mining shovel with a backhoe attachment. If the machine has a front shovel attachment with diesel drive, the letters “FS,” are added to the four-digit number, separated by a space character. An electrically driven hydraulic mining shovel will show an inserted “AC” after the four-digit number. For instance a 6030 FS is a front shovel with a payload of approximately 30 metric tonnes and diesel engines.

The following table gives a summary of all versions currently available.

Diesel Drive		Electric Drive	
Backhoe	Front Shovel	Backhoe	Front Shovel
6015	6015 FS	N/A	N/A
6018	6018 FS	6018 AC	6018 AC FS
6020B	N/A	N/A	N/A
6030	6030 FS	6030 AC	6030 AC FS
6040	6040 FS	6040 AC	6040 AC FS
6050	6050 FS	6050 AC	6050 AC FS
6060	6060 FS	6060 AC	6060 AC FS
N/A	6090 FS	N/A	6090 AC FS

N/A = Not Available

Technical Specifications

All data given herewith is subject to change. The specs/sheets for individual models may have been updated after publishing of this Performance Handbook edition.

Contact Details

If there are any questions or comments regarding the information on hydraulic mining shovels given in this chapter please contact:

Volker.Boernke@cat.com or
Dirk.Tegtmeier@cat.com

TriPower

On all face shovel (FS) models, Caterpillar uses a unique boom design, called TriPower, that employs rotatable triangular rockers to generate superior mechanical leverage and control. This unique Caterpillar design results in:

- Increased effective lifting force
- Constant boom momentum
- Automatic constant bucket angle position in horizontal and vertical direction
- Automatic roll-back limiter

Furthermore, the TriPower system enables Cat hydraulic front shovels to use smaller-diameter boom cylinders. This benefit results in faster lifting speeds.

Superior Oil Cooling System

The independent oil cooling system utilizes dedicated pumps to provide cooling capacity as needed, whether the engine is idling or under load, whereas conventional cooling systems only provide cooling when the engine is under load and the machine is working. Consequently, on Cat hydraulic mining shovels, the hydraulic oil circulates through the cooling system even when the machine is waiting for the next truck. This system provides a more efficient means of cooling, particularly in demanding applications. The radiator fan speed is thermostatically or electronically controlled for greater efficiency.

Closed-Loop Swing Circuit

The Cat closed-loop swing circuit results in fast boom lift motions during swing. The kinetic energy of the swing motion is used during deceleration to support driving the main and auxiliary pumps. Compared to conventional open circuit systems, the Cat closed-loop swing circuit is more energy-efficient, generates less heat and delivers faster speeds.

The new 6020B includes an open-loop swing circuit due to its newly designed advanced hydraulics. Utilizing patent-pending dedicated pump flow allocation technology, hydraulic pumps are allocated to individual circuits on demand, allowing all produced oil flow to be translated into cylinder motion, minimizing hydraulic inefficiencies and heat generation. To fully leverage the advantages of this innovative technology, the open-loop swing system was incorporated for its use of a common set of pumps to serve all functions and the flexibility it offers for utilization of hydraulic flow.

Simple and Efficient Hydraulic System

The main hydraulic valve block is located on top of the boom. This design reduces the total number of hoses that are needed and ensures they are neatly organized for safe operation, easy inspection and fast service. Because float valves are used to lower the boom instead of engaging pumps, the boom moves faster and other operating functions can occur simultaneously, such as bucket curl and stick in/out. This results in faster cycle times.

Monitoring and Diagnostic System

Enhancing diagnostic capabilities and providing detailed troubleshooting functions, the Board Control System uses sensors throughout the machine to monitor operating data, record faults, and notify the operator audibly and visually. This promotes the earliest possible detection of faults and allows for timely maintenance planning and assistance for speedy repair.

Machine Accessibility

Systems throughout Cat hydraulic mining shovels are designed for easy access, enhancing serviceability.

- **Hydraulic Valve Block** — The valve block is located on the boom where it's cleanly laid out and easily accessed by walkways on both sides. This reduces the number of hoses leading from the superstructure.
- **Superstructure** — Exceptional accessibility is provided to systems like the swing motor, swing gearbox and rotary distributor in the well-organized superstructure. The engine is accessible from three sides on most models.

MODEL	6015 Standard Attachment		6015 Mass Excavation Attachment		6018	
Total Flywheel Power: Net	496 kW	665 hp	496 kW	665 hp	824 kW	1104 hp
Approximate Operating Weight*	106 100 kg	233,910 lb	106 000 kg	233,690 lb	186 000 kg	410,060 lb
Standard Bucket Capacity (heaped 1:1)	6.0 m ³	7.8 yd³	7.0 m ³	9.2 yd³	10.0 m ³	13.1 yd³
Standard Engine Model:	C18 ACERT™		C18 ACERT		C18 ACERT	
Number of Engines	1		1		2	
Rated Net Power SAE J1349	496 kW	665 hp	496 kW	665 hp	412 kW	552 hp
Rated Engine RPM	1800		1800		1800	
Displacement	18.1 L	1105 in³	18.1 L	1105 in³	18.1 L	1105 in³
No. Cylinders	6		6		6	
Emission Standards	Tier 4 Interim¹		Tier 4 Interim¹		Tier 4 Interim¹	
Maximum Hydraulic Pump Output at Rated RPM:						
Implement	2 x	2 x	2 x	2 x	4 x	4 x
	552 L/min	146 gpm	552 L/min	146 gpm	412 L/min	109 gpm
Swing	287 L/min	76 gpm	287 L/min	76 gpm	2 x	2 x
					288 L/min	76 gpm
Relief Valve Settings:						
Implement Circuits (attachment)	30 000 kPa	4350 psi	30 000 kPa	4350 psi	30 000 kPa	4350 psi
Travel Circuits	30 000 kPa	4350 psi	30 000 kPa	4350 psi	30 000 kPa	4350 psi
Swing Circuits	35 000 kPa	5080 psi	35 000 kPa	5080 psi	37 000 kPa	5365 psi
Pilot Circuits	3500 kPa	508 psi	3500 kPa	508 psi	3500 kPa	508 psi
Maximum Swing Speed	5.1 RPM		5.1 RPM		4.7 RPM	
Maximum Drawbar Pull	652 kN	146,575 lbf	652 kN	146,575 lbf	1239 kN	278,440 lbf
Maximum Travel Speed at Rated RPM:						
Low	—		—		—	
High	2.7 km/h	1.7 mph	2.7 km/h	1.7 mph	2.3 km/h	1.43 mph
Standard Track Pad Width	600 mm	2'0"	600 mm	2'0"	800 mm	2'7"
Track Gauge	3800 mm	12'6"	3800 mm	12'6"	4500 mm	14'9"
Overall Track Length	6010 mm	19'9"	6010 mm	19'9"	7120 mm	23'4"
Fuel Tank Capacity	1300 L	343 U.S. gal	1300 L	343 U.S. gal	3200 L	845 U.S. gal
Hydraulic Oil System (includes tank)	1700 L	449 U.S. gal	1700 L	449 U.S. gal	2500 L	660 U.S. gal
Hydraulic Oil Tank	1300 L	343 U.S. gal	1300 L	343 U.S. gal	2000 L	528 U.S. gal
Standard Backhoe Attachment:						
Monoboom	7800 mm	25'7"	7300 mm	23'11"	8500 mm	27'11"
Stick	3300 mm	10'10"	2800 mm	9'2"	4500 mm	14'9"
Bucket Range	4.6-7.0 m ³	6.0-9.2 yd³	4.6-7.0 m ³	6.0-9.2 yd³	7.5-10.0 m ³	9.8-13.1 yd³
Maximum Tearout Force	375 kN	84,270 lbf	390 kN	87,640 lbf	540 kN	121,350 lbf
Maximum Breakout Force	380 kN	85,400 lbf	410 kN	92,140 lbf	510 kN	114,610 lbf

*Operating weights include coolant, lubricants, full fuel tank, standard track pads, standard bucket and operator.

¹ There are also products available to meet Tier 3/Stage IIIA/Japan 2006 (Tier 3) equivalent emission standards. Please contact your local Cat dealer for product availability.

MODEL	6020B		6030		6040	
Total Flywheel Power: Net	778 kW	1043 hp	1140 kW	1530 hp	1516 kW	2032 hp
Approximate Operating Weight*	230 500 kg	508,160 lb	296 500 kg	653,660 lb	407 300 kg	897,930 lb
Standard Bucket Capacity (heaped 1:1)	12.0 m ³	15.7 yd³	17.0 m ³	22.2 yd³	22.0 m ³	28.8 yd³
Standard Engine Model:	C32 ACERT		C27 ACERT		C32 ACERT	
Number of Engines	1		2		2	
Rated Net Power SAE J1349	778 kW	1043 hp	570 kW	765 hp	758 kW	1016 hp
Rated Engine RPM	1800		1800		1750	
Displacement	32.0 L	1959 in³	27.0 L	1648 in³	32.1 L	1959 in³
No. Cylinders	12		12		12	
Emission Standards	Tier 4 Interim equivalent¹		Tier 4 Interim equivalent¹		Tier 4 Interim equivalent¹	
Maximum Hydraulic Pump Output at Rated RPM:						
Implement	2350 L/min	621 gpm	4 x 552 L/min	4 x 146 gpm	4 x 724 L/min	4 x 191 gpm
Swing	783 L/min	216 gpm	2 x 394 L/min	2 x 104 gpm	4 x 321 L/min	4 x 85 gpm
Relief Valve Settings:						
Implement Circuits (attachment)	31 000 kPa	4495 psi	31 000 kPa	4465 psi	30 000 kPa	4350 psi
Travel Circuits	31 000 kPa	4495 psi	36 000 kPa	5220 psi	35 000 kPa	5080 psi
Swing Circuits	35 000 kPa	5080 psi	35 000 kPa	5080 psi	35 000 kPa	5080 psi
Pilot Circuits	3500 kPa	508 psi	3500 kPa	508 psi	3500 kPa	508 psi
Maximum Swing Speed	4.9 rpm		4.6 RPM		4.7 RPM	
Maximum Drawbar Pull	1052 kN	236,420 lb	1637 kN	367,880 lbf	2097 kN	471,260 lbf
Maximum Travel Speed at Rated RPM:						
Low	1.2 km/h	0.75 mph	1.68 mph	0.87 mph	1.5 km/h	0.93 mph
High	2.7 km/h	1.68 mph	2.7 km/h	1.68 mph	2.5 km/h	1.55 mph
Standard Track Pad Width	800 mm	2'7"	1000 mm	3'3"	1200 mm	3'11"
Track Gauge	4700 mm	15'5"	4800 mm	15'9"	5400 mm	17'9"
Overall Track Length	7520 mm	24'8"	7660 mm	25'2"	8090 mm	26'7"
Fuel Tank Capacity	3600 L	951 U.S. gal	5130 L	1355 U.S. gal	7800 L	2060 U.S. gal
Hydraulic Oil System (includes tank)	4300 L	1136 U.S. gal	4570 L	1255 U.S. gal	5800 L	1532 U.S. gal
Hydraulic Oil Tank	2800 L	740 U.S. gal	3400 L	898 U.S. gal	3400 L	898 U.S. gal
Standard Backhoe Attachment:						
Monoboomb	8700 mm	28'7"	8500 mm	27'11"	9500 mm	31'2"
Stick	3900 mm	12'10"	4000 mm	13'1"	4600 mm	15'1"
Bucket Range	12.0- 13.7 m ³	15.7- 17.9 yd³	12.0- 17.0 m ³	15.7- 22.2 yd³	15.0- 24.0 m ³	19.6- 31.4 yd³
Maximum Tearout Force	630 kN	141,580 lb	920 kN	206,750 lbf	1020 kN	229,220 lbf
Maximum Breakout Force	730 kN	164,050 lb	890 kN	200,010 lbf	1120 kN	251,700 lbf

*Operating weights include coolant, lubricants, full fuel tank, standard track pads, standard bucket and operator.

¹There are also products available to meet Tier 2 equivalent emission standards. Please contact your local Cat dealer for product availability.

MODEL	6050		6060	
Total Flywheel Power: Net	1880 kW	2520 hp	2240 kW	3000 hp
Approximate Operating Weight*	537 000 kg	1,183,870 lb	570 300 kg	1,257,280 lb
Standard Bucket Capacity (heaped 1:1)	28.0 m ³	36.6 yd³	34.0 m ³	44.5 yd³
Standard Engine Model:	QSK38		3512C	
Number of Engines	2		2	
Rated Net Power SAE J1349	940 kW	1260 hp	1120 kW	1500 hp
Rated Engine RPM	1800		1800	
Displacement	37.8 L	2300 in³	58.6 L	3574 in³
No. Cylinders	12		12	
Emission Standards	Tier 4 Interim equivalent¹		Tier 4 Interim equivalent¹	
Optional Engine Model:	K1500E		—	
Number of Engines	2		—	
Rated Net Power SAE J1349	900 kW	1260 hp	—	
Rated Engine RPM	1800		—	
Displacement	37.8 L	2300 in³	—	
No. Cylinders	12		—	
Emission Standards	Tier 1 equivalent		—	
Maximum Hydraulic Pump Output at Rated RPM:				
Implement	4 × 912 L/min	4 × 241 gpm	4 × 1300 L/min	4 × 343 gpm
Swing	4 × 351 L/min	4 × 93 gpm	4 × 352 L/min	4 × 93 gpm
Relief Valve Settings:				
Implement Circuits (attachment)	30 000 kPa	4350 psi	32 000 kPa	4640 psi
Travel Circuits	34 000 kPa	4930 psi	37 000 kPa	5365 psi
Swing Circuits	35 000 kPa	5080 psi	37 000 kPa	5365 psi
Pilot Circuits	4000 kPa	580 psi	3500 kPa	508 psi
Maximum Swing Speed	3.8 RPM		3.8 RPM	
Maximum Drawbar Pull	2576 kN	578,900 lbf	2956 kN	664,300 lbf
Maximum Travel Speed at Rated RPM:				
Low	1.6 km/h	0.99 mph	1.4 km/h	0.87 mph
High	2.3 km/h	1.44 mph	2.0 km/h	1.24 mph
Standard Track Pad Width	1400 mm	4'7"	1400 mm	4'7"
Track Gauge	5600 mm	18'4"	5600 mm	18'4"
Overall Track Length	8540 mm	28'0"	9230 mm	30'3"
Fuel Tank Capacity	10 700 L	2820 U.S. gal	13 000 L	3435 U.S. gal
Hydraulic Oil System (includes tank)	7800 L	2060 U.S. gal	9400 L	2483 U.S. gal
Hydraulic Oil Tank	5500 L	1450 U.S. gal	7100 L	1876 U.S. gal
Standard Backhoe Attachment:				
Monoboom	10 500 mm	34'5"	10 500 mm	34'5"
Stick	5500 mm	18'1"	5000 mm	16'5"
Bucket Range	25.0-28.0 m ³	32.7-36.6 yd³	25.0-34.0 m ³	32.7-44.5 yd³
Maximum Tearout Force	1100 kN	247,200 lbf	1220 kN	274,170 lbf
Maximum Breakout Force	1210 kN	271,920 lbf	1240 kN	278,670 lbf

*Operating weights include coolant, lubricants, full fuel tank, standard track pads, standard bucket and operator.

¹There are also products available to meet Tier 2 equivalent emission standards. Please contact your local Cat dealer for product availability.

MODEL	6018 AC		6030 AC		6040 AC	
Total Output	650 kW		1000 kW		1400 kW	
Operating Weight	186 700 kg	411,600 lb	296 500 kg	653,660 lb	407 000 kg	897,270 lb
Electric Motor Type:	Squirrel cage induction motor		Squirrel cage induction motor		Squirrel cage induction motor	
Number of Motors	1		1		1	
Standard Voltage*	6.3 kV ± 10%		6.3 kV ± 10%		6.6 kV ± 10%	
Rated Current I _N (at standard voltage)	72 A		109 A		156 A	
Standard Frequency*	50 Hz		50 Hz		50 Hz	
Standard Revolutions*	1500 RPM		1500 RPM		1500 RPM	
Starting Current (direct start)	350% of I_N		450% of I_N		350% of I_N	
Starting Current (soft start, optional)	197% of I_N		253% of I_N		197% of I_N	
Maximum Hydraulic Pump Output at Rated RPM:						
Implement	2 x	2 x	4 x	4 x	4 x	4 x
Swing	578 L/min	153 gpm	543 L/min	143 gpm	746 L/min	197 gpm
	516 L/min	136 gpm	2 x	2 x	3 x	3 x
			426 L/min	113 gpm	491 L/min	130 gpm
Maximum Swing Speed	4.1 RPM		5.0 RPM		5.1 RPM	
Maximum Travel Speed at Standard RPM:						
Low	—		1.4 km/h	0.87 mph	1.5 km/h	0.93 mph
High	1.7 km/h	1.06 mph	2.7 km/h	1.68 mph	2.5 km/h	1.55 mph

*Other voltages and frequencies like 7.2 kV/60 Hz are available on request.
NOTE: Other specifications of the diesel driven shovels remain unchanged.

MODEL	6050 AC		6060 AC	
Total Output	1600 kW		1800 kW	
Operating Weight	524 500 kg	1,156,310 lb	547 700 kg	1,207,460 lb
Electric Motor Type:	Squirrel cage induction motor		Squirrel cage induction motor	
Number of Motors	1		1	
Standard Voltage*	6.6 kV ± 10%		6.6 kV ± 10%	
Rated Current I _N (at standard voltage)	174 A		194 A	
Standard Frequency*	50 Hz		50 Hz	
Standard Revolutions*	1500 RPM		1500 RPM	
Starting Current (direct start)	350% of I_N		350% of I_N	
Starting Current (soft start, optional)	197% of I_N		197% of I_N	
Maximum Hydraulic Pump Output at Rated RPM:				
Implement	4 × 933 L/min	4 × 246 gpm	4 × 933 L/min	4 × 246 gpm
Swing	3 × 491 L/min	3 × 131 gpm	3 × 491 L/min	3 × 131 gpm
Maximum Swing Speed	4.0 RPM		4.0 RPM	
Maximum Travel Speed at Standard RPM:				
Low	1.6 km/h	0.99 mph	1.4 km/h	0.87 mph
High	2.3 km/h	1.44 mph	2.7 km/h	1.68 mph

*Other voltages and frequencies like 7.2 kV/60 Hz are available on request.

NOTE: Other specifications of the diesel driven shovels remain unchanged.

MODEL	6015 FS		6018 FS	
Total Flywheel Power: Net	496 kW	665 hp	824 kW	1104 hp
Approximate Operating Weight*	104 900 kg	231,260 lb	183 400 kg	404,320 lb
Standard Bucket Capacity (heaped 2:1)	7.0 m ³	9.2 yd³	10.0 m ³	13.1 yd³
Standard Engine Model:	C18 ACERT		C18 ACERT	
Number of Engines	1		2	
Rated Net Power SAE J1349	496 kW	665 hp	412 kW	552 hp
Rated Engine RPM	1800		1800	
Displacement	18.1 L	1105 in³	18.1 L	1105 in³
No. Cylinders	6		6	
Emission Standards	Tier 4 Interim¹		Tier 4 Interim¹	
Maximum Hydraulic Pump Output at Rated RPM:				
Implement	2 × 552 L/min	2 × 146 gpm	4 × 412 L/min	4 × 109 gpm
Swing	287 L/min	76 gpm	2 × 288 L/min	2 × 76 gpm
Relief Valve Settings:				
Implement Circuits (attachment)	30 000 kPa	4350 psi	30 000 kPa	4350 psi
Travel Circuits	30 000 kPa	4350 psi	30 000 kPa	4350 psi
Swing Circuits	35 000 kPa	5080 psi	37 000 kPa	5365 psi
Pilot Circuits	3500 kPa	508 psi	3500 kPa	508 psi
Maximum Swing Speed	5.1 RPM		4.7 RPM	
Maximum Drawbar Pull	652 kN	146,575 lbf	1239 kN	278,440 lbf
Maximum Travel Speed at Rated RPM:				
Low	—		—	
High	2.7 km/h	1.7 mph	2.3 km/h	1.43 mph
Standard Track Pad Width	600 mm	2'0"	800 mm	2'7"
Track Gauge	3800 mm	12'6"	4500 mm	14'9"
Overall Track Length	6010 mm	19'9"	7120 mm	23'4"
Fuel Tank Capacity	1300 L	343 U.S. gal	3200 L	845 U.S. gal
Hydraulic Oil System (includes tank)	1700 L	449 U.S. gal	2500 L	660 U.S. gal
Hydraulic Oil Tank	1300 L	343 U.S. gal	2000 L	528 U.S. gal
TriPower Face Shovel Attachment:				
Boom	5050 mm	16'7"	6350 mm	20'10"
Stick	3550 mm	11'8"	4100 mm	13'5"
Bucket Range	4.5-7.0 m ³	5.9-9.2 yd³	8.0-10.0 m ³	10.5-13.1 yd³
Maximum Crowd Force	645 kN	144,950 lbf	910 kN	204,500 lbf
Maximum Breakout Force	480 kN	107,870 lbf	730 kN	164,050 lbf

*Operating weights include coolant, lubricants, full fuel tank, standard track pads, standard bucket and operator.

¹ There are also products available to meet Tier 3/Stage IIIA/Japan 2006 (Tier 3) equivalent emission standards. Please contact your local Cat dealer for product availability.

MODEL	6030 FS		6040 FS		6050 FS	
Total Flywheel Power: Net	1140 kW	1530 hp	1516 kW	2032 hp	1880 kW	2520 hp
Approximate Operating Weight*	294 300 kg	648,810 lb	404 600 kg	891,980 lb	527 600 kg	1,163,150 lb
Standard Bucket Capacity (heaped 2:1)	16.5 m ³	21.6 yd³	22.0 m ³	28.8 yd³	26.0 m ³	34.0 yd³
Standard Engine Model:	C27 ACERT		C32 ACERT		QSK38	
Number of Engines	2		2		2	
Rated Net Power SAE J1349	570 kW	765 hp	758 kW	1016 hp	900 kW	1260 hp
Rated Engine RPM	1800		1750		1800	
Displacement	27.0 L	1648 in³	32.1 L	1959 in³	37.8 L	2300 in³
No. Cylinders	12		12		12	
Emission Standards	Tier 4 Interim equivalent¹		Tier 4 Interim equivalent¹		Tier 4 Interim equivalent¹	
Optional Engine Model:	—		—		K1500E	
Number of Engines	—		—		2	
Rated Net Power SAE J1349	—		—		900 kW	1260 hp
Rated Engine RPM	—		—		1800	
Displacement	—		—		37.8 L	2300 in³
No. Cylinders	—		—		12	
Emission Standards	—		—		Tier 1 equivalent	
Maximum Hydraulic Pump Output at Rated RPM:						
Implement	4 x	4 x	4 x	4 x	4 x	4 x
	552 L/min	146 gpm	724 L/min	191 gpm	912 L/min	241 gpm
Swing	2 x	2 x	4 x	4 x	4 x	4 x
	288 L/min	104 gpm	321 L/min	85 gpm	351 L/min	93 gpm
Relief Valve Settings:						
Implement Circuits (attachment)	31 000 kPa	4465 psi	30 000 kPa	4350 psi	30 000 kPa	4350 psi
Travel Circuits	36 000 kPa	5220 psi	35 000 kPa	5080 psi	34 000 kPa	4930 psi
Swing Circuits	35 000 kPa	5080 psi	35 000 kPa	5080 psi	35 000 kPa	5080 psi
Pilot Circuits	3500 kPa	508 psi	3500 kPa	508 psi	4000 kPa	580 psi
Maximum Swing Speed	4.6 RPM		4.7 RPM		3.8 RPM	
Maximum Drawbar Pull	1637 kN	367,880 lbf	2097 kN	471,260 lbf	2576 kN	578,900 lbf
Maximum Travel Speed at Rated RPM:						
Low	1.4 km/h	0.87 mph	1.5 km/h	0.93 mph	1,6 km/h	0.99 mph
High	2.7 km/h	1.68 mph	2.5 km/h	1.55 mph	2.3 km/h	1.44 mph
Standard Track Pad Width	1000 mm	3'3"	1200 mm	3'11"	1400 mm	4'7"
Track Gauge	4800 mm	15'9"	5400 mm	17'9"	5600 mm	18'4"
Overall Track Length	7660 mm	25'2"	8090 mm	26'7"	8540 mm	28'0"
Fuel Tank Capacity	5130 L	1355 U.S. gal	7800 L	2060 U.S. gal	10 700 L	2820 U.S. gal
Hydraulic Oil System (includes tank)	3500 L	925 U.S. gal	5800 L	1532 U.S. gal	7800 L	2060 U.S. gal
Hydraulic Oil Tank	2500 L	660 U.S. gal	3400 L	898 U.S. gal	5500 L	1450 U.S. gal
TriPower Face Shovel Attachment:						
Boom	6200 mm	20'4"	7300 mm	23'11"	8000 mm	26'2"
Stick	4400 mm	14'5"	4600 mm	15'1"	5100 mm	16'9"
Bucket Range	10.0-	13.1-	15.0-	19.6-	18.0-	23.5-
	16.5 m ³	21.6 yd³	22.0 m ³	28.8 yd³	28.0 m ³	36.6 yd³
Maximum Crowd Force	1320 kN	296,640 lbf	1730 kN	388,780 lbf	1930 kN	433,730 lbf
Maximum Breakout Force	960 kN	215,740 lbf	1200 kN	269,680 lbf	1530 kN	343,840 lbf

*Operating weights include coolant, lubricants, full fuel tank, standard track pads, standard bucket and operator.

¹ There are also products available to meet Tier 2 equivalent emission standards. Please contact your local Cat dealer for product availability.

MODEL	6060 FS		6090 FS	
Total Flywheel Power: Net	2240 kW	3000 hp	3360 kW	4500 hp
Approximate Operating Weight*	568 900 kg	1,254,200 lb	980 000 kg	2,160,510 lb
Standard Bucket Capacity (heaped 2:1)	34.0 m ³	44.5 yd³	52.0 m ³	68.0 yd³
Standard Engine Model:	3512C		QSK60	
Number of Engines	2		2	
Rated Net Power SAE J1349	1120 kW	1500 hp	1680 kW	2250 hp
Rated Engine RPM	1800		1800	
Displacement	58.6 L	3574 in³	60.2 L	3674 in³
No. Cylinders	12		16	
Emission Standards	Tier 4 Interim equivalent¹		Tier 4 Interim equivalent¹	
Maximum Hydraulic Pump Output at Rated RPM:				
Implement	4 × 1300 L/min	4 × 343 gpm	8 × 936 L/min	8 × 247 gpm
Swing	4 × 352 L/min	4 × 93 gpm	6 × 488 L/min	6 × 129 gpm
Relief Valve Settings:				
Implement Circuits (attachment)	32 000 kPa	4640 psi	30 000 kPa	4350 psi
Travel Circuits	37 000 kPa	5365 psi	36 000 kPa	5220 psi
Swing Circuits	37 000 kPa	5365 psi	35 000 kPa	5080 psi
Pilot Circuits	3500 kPa	508 psi	3500 kPa	508 psi
Maximum Swing Speed	3.8 RPM		3.9 RPM	
Maximum Drawbar Pull	2956 kN	664,300 lbf	4338 kN	974,880 lbf
Maximum Travel Speed at Rated RPM:				
Low	1.4 km/h	0.87 mph	1.4 km/h	0.9 mph
High	2.0 km/h	1.24 mph	1.9 km/h	1.2 mph
Standard Track Pad Width	1400 mm	4'7"	2000 mm	6'7"
Track Gauge	5600 mm	18'4"	6600 mm	21'8"
Overall Track Length	9230 mm	30'3"	10 980 mm	36'0"
Fuel Tank Capacity	13 000 L	3435 U.S. gal	16 400 L	4330 U.S. gal
Hydraulic Oil System (includes tank)	9400 L	2483 U.S. gal	13 000 L	3450 U.S. gal
Hydraulic Oil Tank	7100 L	1876 U.S. gal	10 000 L	2640 U.S. gal
TriPower Face Shovel Attachment:				
Boom	8000 mm	26'2"	9500 mm	31'2"
Stick	5100 mm	16'9"	5800 mm	19'0"
Bucket Range	21.0-34.0 m ³	27.5-44.5 yd³	37.0-52.0 m ³	48.8-68.0 yd³
Maximum Crowd Force	2250 kN	505,640 lbf	3090 kN	694,420 lbf
Maximum Breakout Force	1740 kN	391,030 lbf	2420 kN	543,850 lbf

*Operating weights include coolant, lubricants, full fuel tank, standard track pads, standard bucket and operator.

¹There are also products available to meet Tier 2 equivalent emission standards. Please contact your local Cat dealer for product availability.

MODEL	6018 AC FS		6030 AC FS		6040 AC FS	
Total Output	650 kW		1000 kW		1400 kW	
Operating Weight	184 100 kg	405,870 lb	294 300 kg	648,810 lb	404 300 kg	891,320 lb
Electric Motor Type:	Squirrel cage induction motor		Squirrel cage induction motor		Squirrel cage induction motor	
Number of Motors	1		1		1	
Standard Voltage*	6.3 kV ± 10%		6.3 kV ± 10%		6.6 kV ± 10%	
Rated Current I _N (at standard voltage)	72 A		109 A		156 A	
Standard Frequency*	50 Hz		50 Hz		50 Hz	
Standard Revolutions*	1500 RPM		1500 RPM		1500 RPM	
Starting Current (direct start)	350% of I_N		450% of I_N		350% of I_N	
Starting Current (soft start, optional)	197% of I_N		253% of I_N		197% of I_N	
Maximum Hydraulic Pump Output at Rated RPM:						
Implement	2 x	2 x	4 x	4 x	4 x	4 x
Swing	578 L/min	153 gpm	543 L/min	143 gpm	746 L/min	197 gpm
	516 L/min	136 gpm	2 x	2 x	3 x	3 x
			426 L/min	113 gpm	491 L/min	130 gpm
Maximum Swing Speed	4.1 RPM		5.0 RPM		5.1 RPM	
Maximum Travel Speed at Standard RPM:						
Low	—		1.4 km/h	0.87 mph	1.5 km/h	0.93 mph
High	1.7 km/h	1.06 mph	2.7 km/h	1.68 mph	2.5 km/h	1.55 mph

*Other voltages and frequencies like 7.2 kV/60 Hz are available on request.

NOTE: Other specifications of the diesel driven shovels remain unchanged.

MODEL	6050 AC FS		6060 AC FS		6090 AC FS	
Total Output	1600 kW		1800 kW		3200 kW	
Operating Weight	515 100 kg 1,135,590 lb		546 300 kg 1,204,370 lb		955 000 kg 2,105,410 lb	
Electric Motor Type:	Squirrel cage induction motor		Squirrel cage induction motor		Squirrel cage induction motor	
Number of Motors	1		1		2	
Standard Voltage*	6.6 kV ± 10%		6.6 kV ± 10%		6.6 kV ± 10%	
Rated Current I _N (at standard voltage)	174 A		194 A		332 A	
Standard Frequency*	50 Hz		50 Hz		50 Hz	
Standard Revolutions*	1500 RPM		1500 RPM		1500 RPM	
Starting Current (direct start)	350% of I_N		350% of I_N		780 A	
Starting Current (soft start, optional)	197% of I_N		197% of I_N		N/A	
Maximum Hydraulic Pump Output at Rated RPM:						
Implement	4 x	4 x	4 x	4 x	8 x	8 x
	933 L/min	246 gpm	933 L/min	246 gpm	943 L/min	249 gpm
Swing	3 x	3 x	3 x	3 x	6 x	6 x
	491 L/min	131 gpm	491 L/min	131 gpm	496 L/min	131 gpm
Maximum Swing Speed	4.0 RPM		4.0 RPM		4.1 RPM	
Maximum Travel Speed at Standard RPM:						
Low	1.6 km/h	0.99 mph	1.4 km/h	0.87 mph	1.4 km/h	0.9 mph
High	2.3 km/h	1.44 mph	2.7 km/h	1.68 mph	1.9 km/h	1.2 mph

*Other voltages and frequencies like 7.2 kV/60 Hz are available on request.

NOTE: Other specifications of the diesel driven shovels remain unchanged.

N/A = Not Available

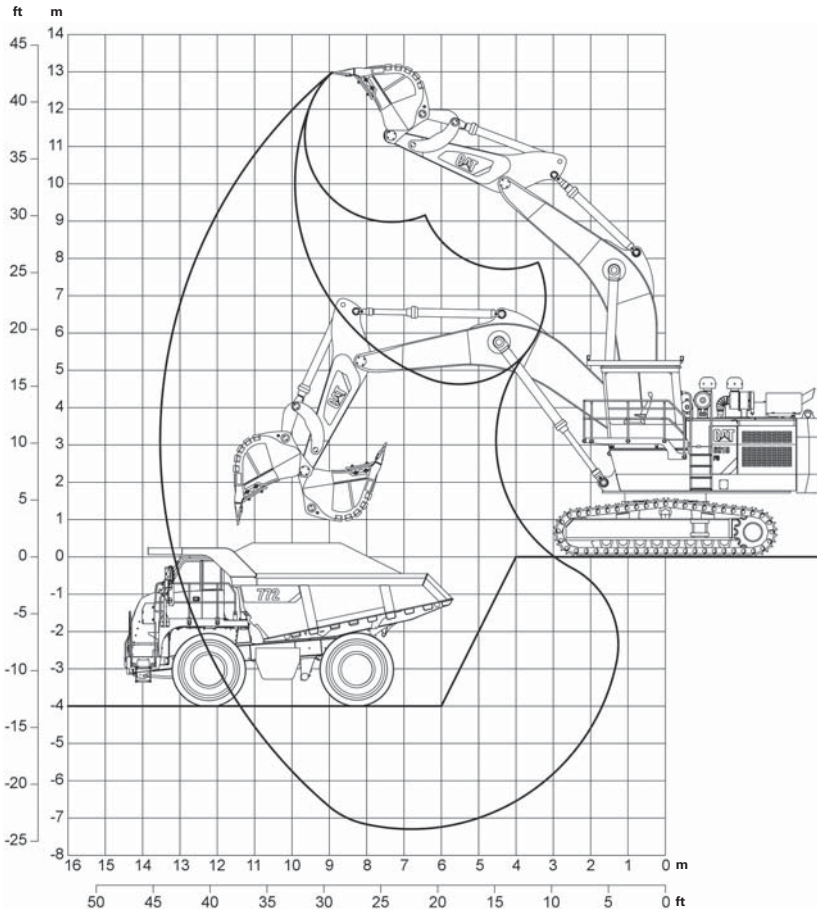

6015

Standard Attachment

MODEL

Working Range

Maximum Digging Depth
 Maximum Digging Reach
 Maximum Digging Height

7.3 m 23'11"
 13.5 m 44'3"
 13.0 m 42'8"

Digging Forces

Maximum Tearout Force (arm cylinder)
 Maximum Breakout Force (bucket cylinder)

375 kN 84,270 lbf
 380 kN 85,400 lbf

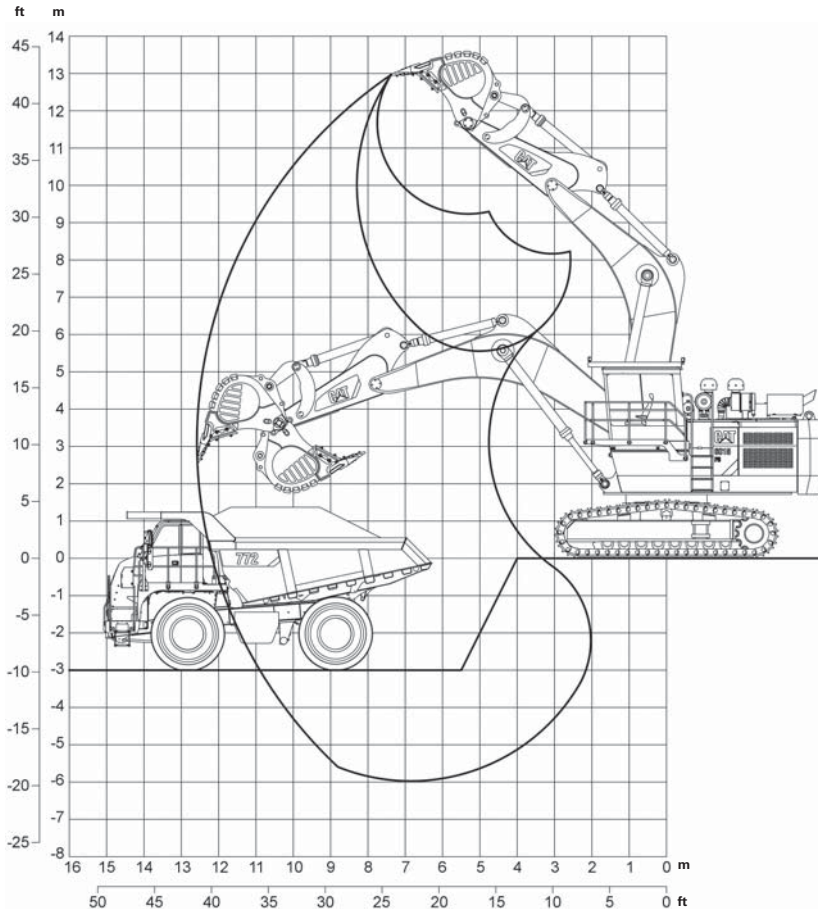

6015

Mass Excavation Attachment

MODEL

Working Range

Maximum Digging Depth
 Maximum Digging Reach
 Maximum Digging Height

6.0 m **19'8"**
 12.6 m **41'4"**
 13.0 m **42'8"**

Digging Forces

Maximum Tearout Force (arm cylinder)
 Maximum Breakout Force (bucket cylinder)

390 kN **87,640 lbf**
 410 kN **92,140 lbf**

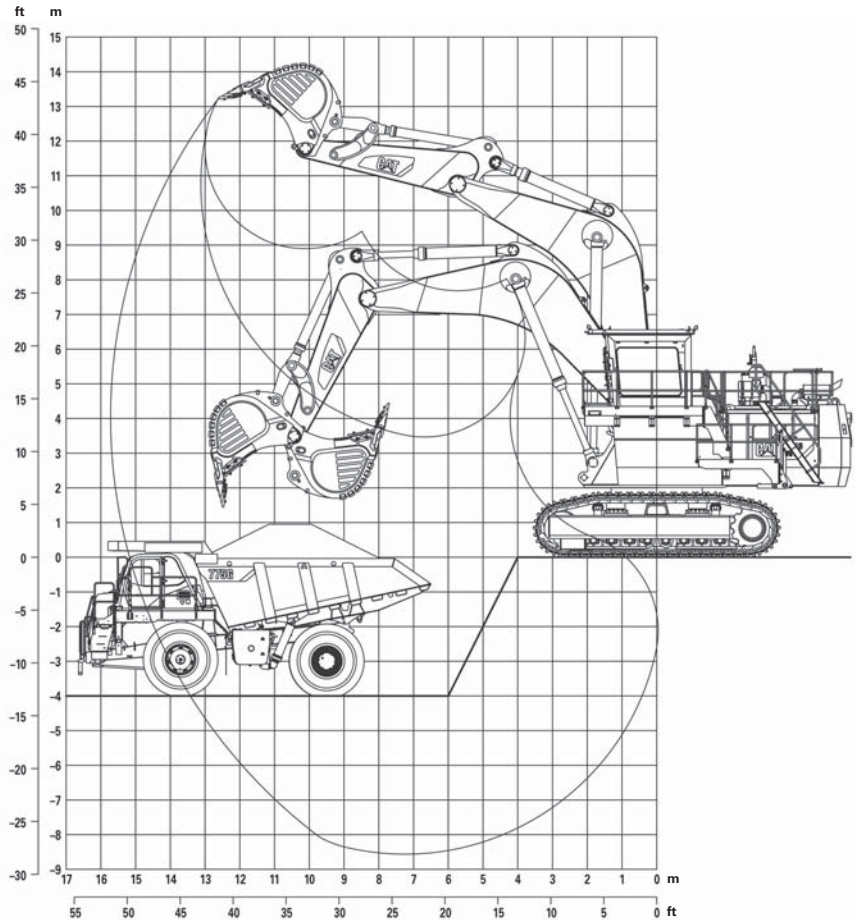

MODEL

6018

Working Range

Maximum Digging Depth	8.5 m	27'11"
Maximum Digging Reach	15.6 m	51'2"
Maximum Digging Height	13.2 m	43'4"

Digging Forces

Maximum Tearout Force (arm cylinder)	540 kN	121,350 lbf
Maximum Breakout Force (bucket cylinder)	510 kN	114,610 lbf

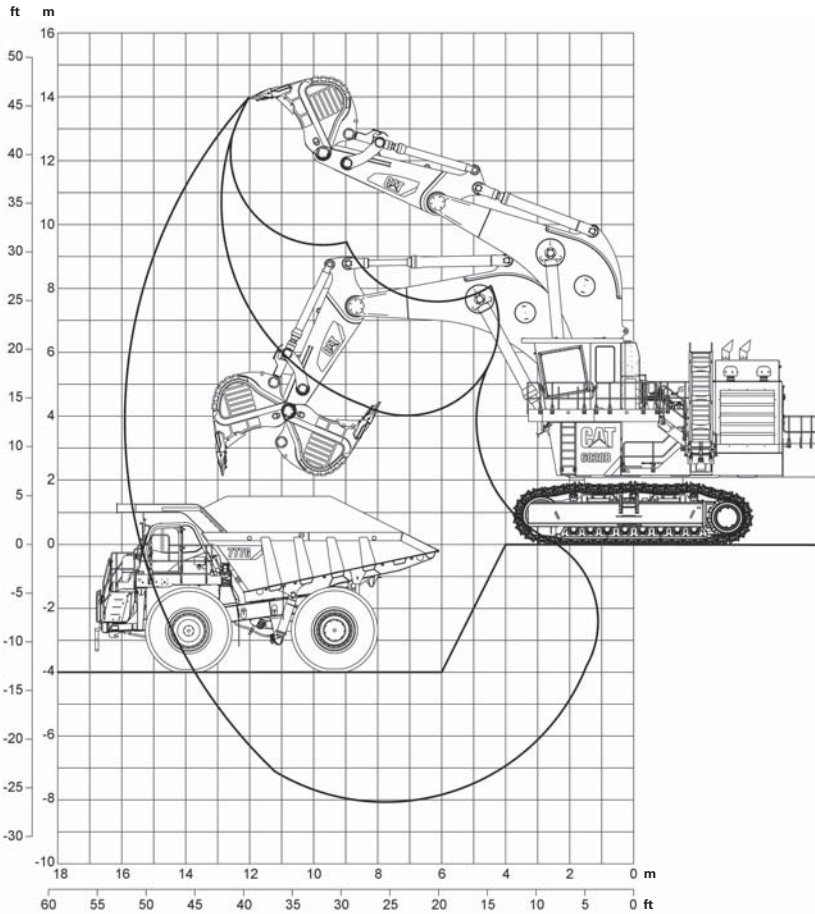

MODEL

6020B

Working Range

Maximum Digging Depth	8.1 m	26'7"
Maximum Digging Reach	15.9 m	52'2"
Maximum Digging Height	13.9 m	45'7"

Digging Forces

Maximum Tearout Force (arm cylinder)	630 kN	141,580 lb
Maximum Breakout Force (bucket cylinder)	730 kN	164,050 lb

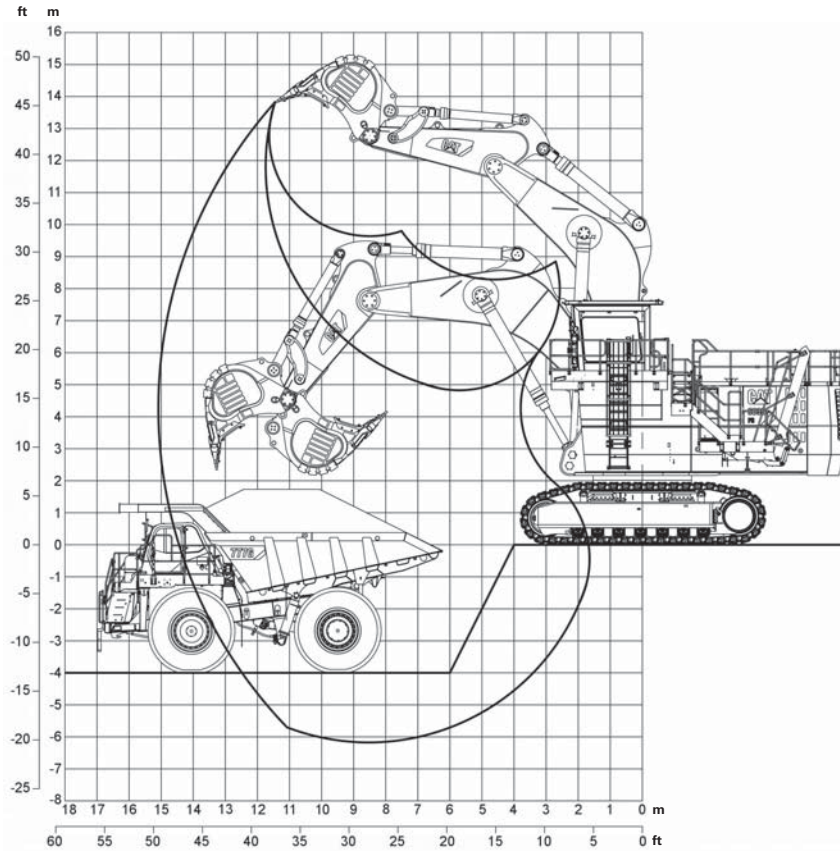

MODEL

6030

Working Range

Maximum Digging Depth	6.2 m	20'4"
Maximum Digging Reach	15.1 m	49'6"
Maximum Digging Height	13.8 m	45'3"

Digging Forces

Maximum Tearout Force (arm cylinder)	920 kN	206,750 lbf
Maximum Breakout Force (bucket cylinder)	890 kN	200,010 lbf

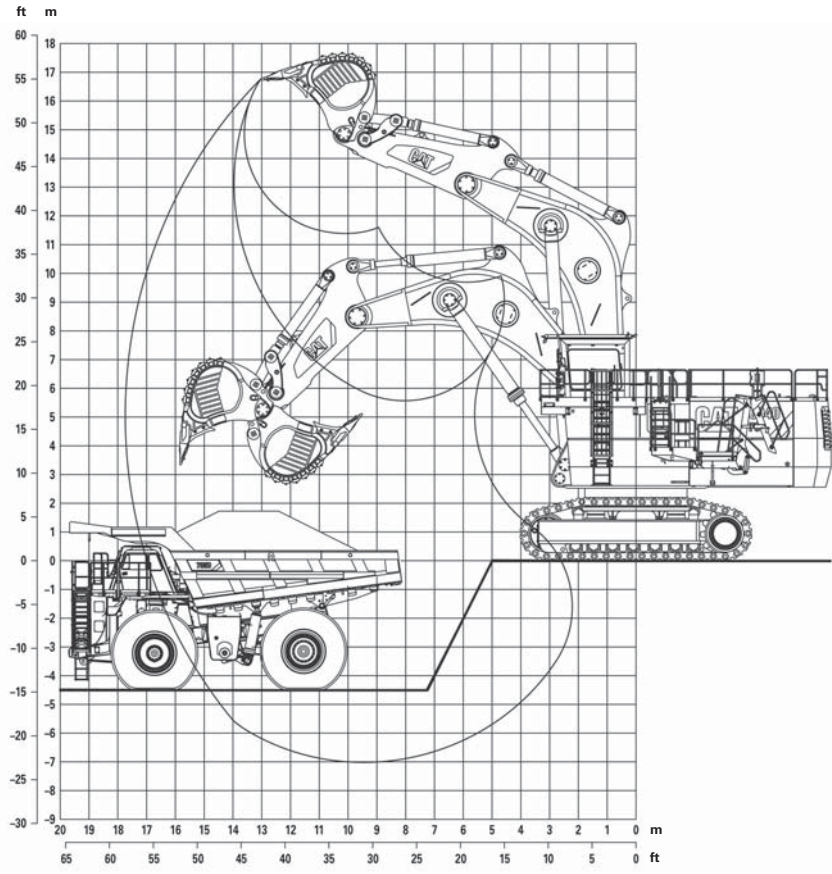

MODEL

6040

Working Range

Maximum Digging Depth	7.0 m	23'0"
Maximum Digging Reach	17.7 m	58'1"
Maximum Digging Height	16.8 m	55'1"

Digging Forces

Maximum Tearout Force (arm cylinder)	1020 kN	229,220 lbf
Maximum Breakout Force (bucket cylinder)	1120 kN	251,700 lbf

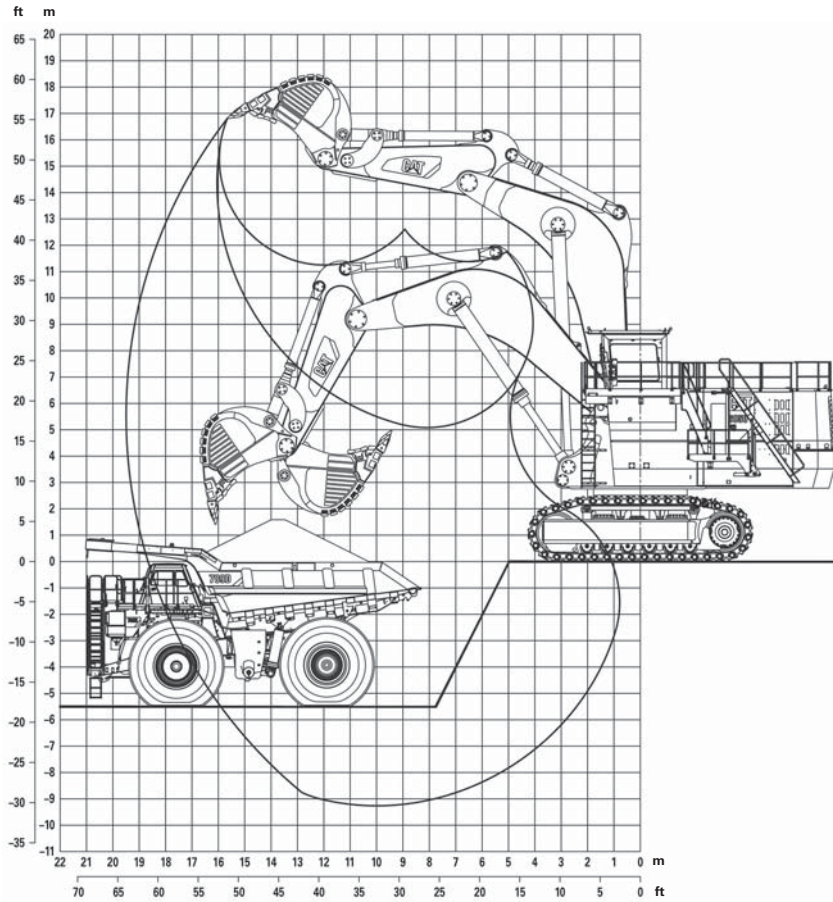

MODEL

6050

Working Range

Maximum Digging Depth	9.2 m	30'2"
Maximum Digging Reach	19.5 m	64'0"
Maximum Digging Height	16.8 m	55'1"

Digging Forces

Maximum Tearout Force (arm cylinder)	1100 kN	247,220 lbf
Maximum Breakout Force (bucket cylinder)	1210 kN	271,920 lbf

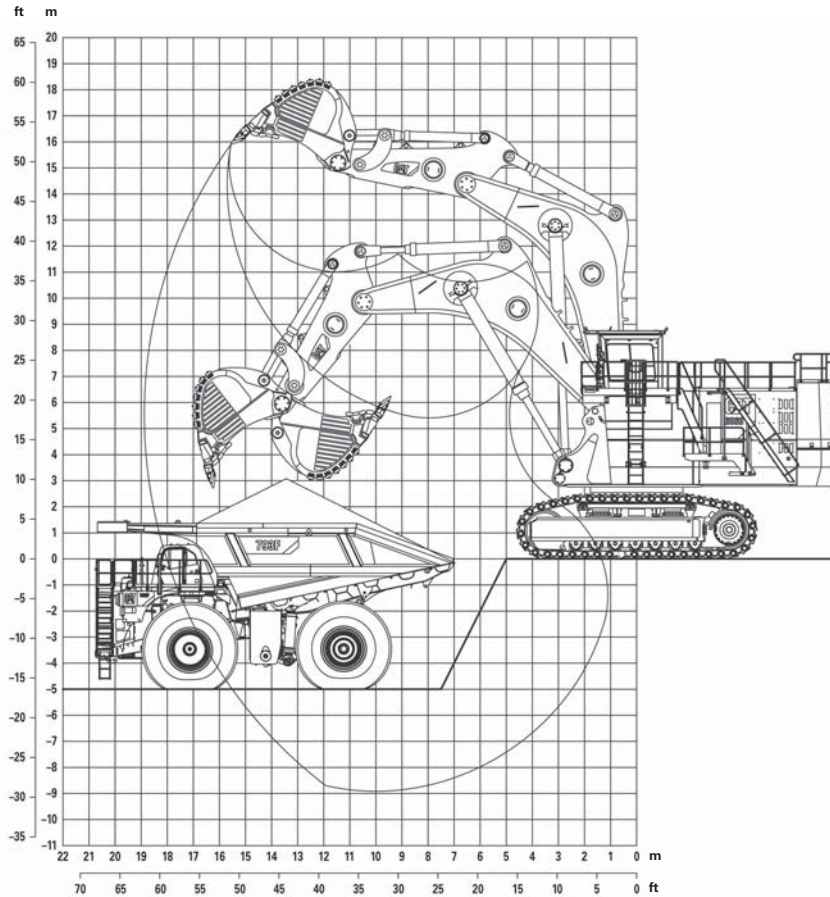

MODEL

6060

Working Range

Maximum Digging Depth	8.9 m	29'2"
Maximum Digging Reach	18.9 m	62'0"
Maximum Digging Height	15.9 m	52'2"

Digging Forces

Maximum Tearout Force (arm cylinder)	1220 kN	274,170 lbf
Maximum Breakout Force (bucket cylinder)	1240 kN	278,670 lbf

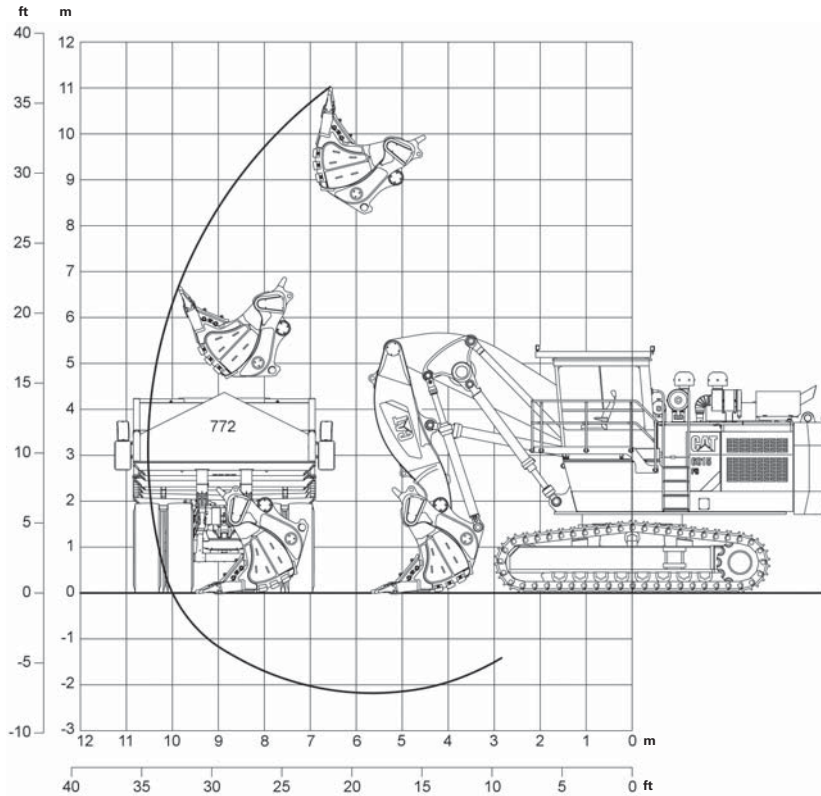

MODEL

6015 FS

Working Range

Maximum Digging Height	11.0 m	36'1"
Maximum Digging Reach	10.5 m	34'5"
Maximum Digging Depth	2.2 m	7'3"
Maximum Dumping Height	8.8 m	28'10"
Crowd Distance on Level	3.9 m	12'10"

Digging Forces

Maximum Crowd Force (arm cylinder)	645 kN	144,950 lbf
Maximum Crowd Force at Ground Level (arm cylinder)	465 kN	104,500 lbf
Maximum Breakout Force (bucket cylinder)	480 kN	107,870 lbf

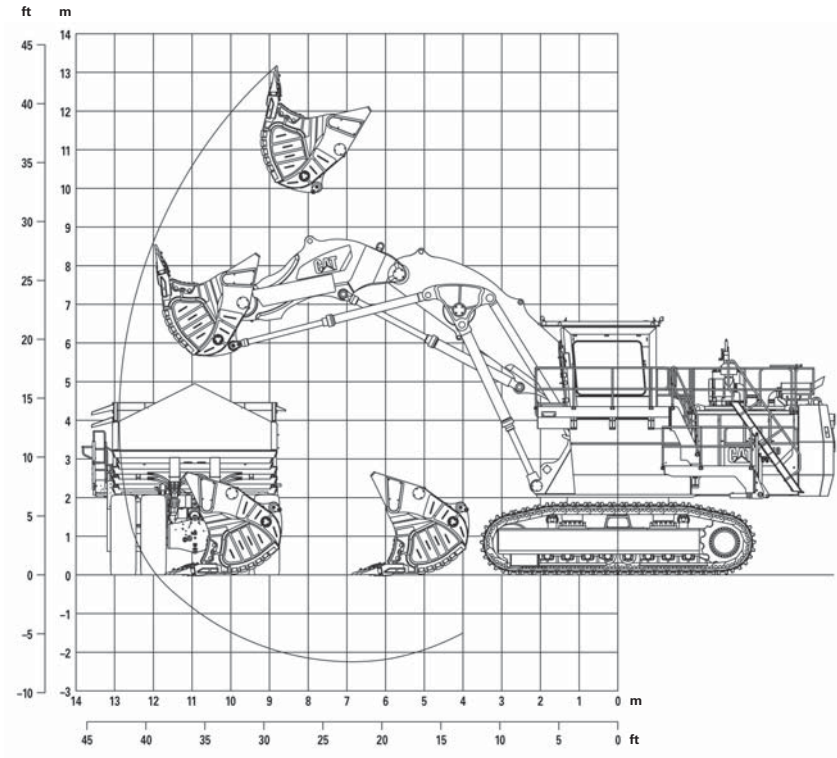

MODEL

6018 FS

Working Range

Maximum Digging Height	13.2 m	43'4"
Maximum Digging Reach	12.9 m	42'4"
Maximum Digging Depth	2.3 m	7'7"
Maximum Dumping Height	10.1 m	33'2"
Crowd Distance on Level	4.8 m	15'9"

Digging Forces

Maximum Crowd Force (arm cylinder)	910 kN	204,500 lbf
Maximum Crowd Force at Ground Level (arm cylinder)	810 kN	182,030 lbf
Maximum Breakout Force (bucket cylinder)	730 kN	164,050 lbf

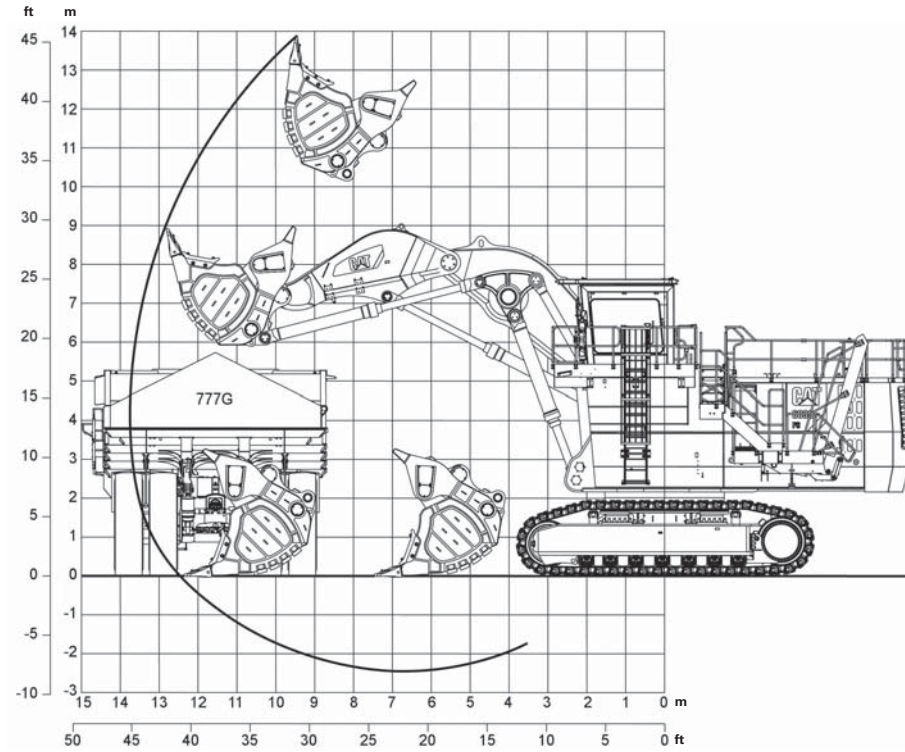

MODEL

6030 FS

Working Range

Maximum Digging Height	13.9 m	45'7"
Maximum Digging Reach	13.7 m	44'11"
Maximum Digging Depth	2.5 m	8'2"
Maximum Dumping Height	10.7 m	35'1"
Crowd Distance on Level	4.9 m	16'1"

Digging Forces

Maximum Crowd Force (arm cylinder)	1320 kN	296,640 lbf
Maximum Crowd Force at Ground Level (arm cylinder)	1210 kN	271,920 lbf
Maximum Breakout Force (bucket cylinder)	960 kN	215,740 lbf

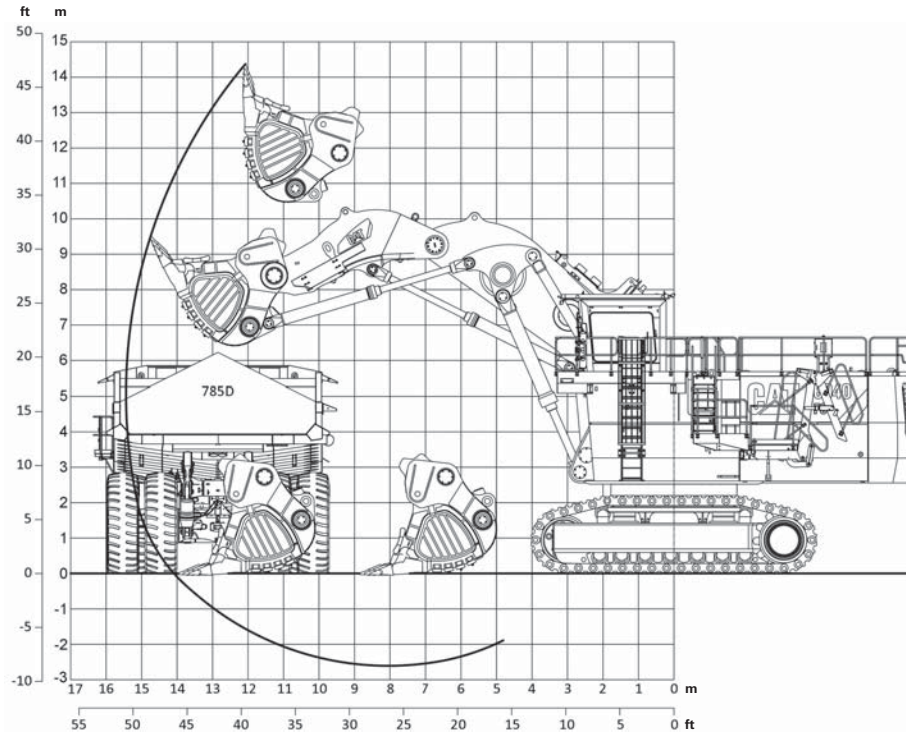

MODEL

6040 FS

Working Range

Maximum Digging Height	14.4 m	47'3"
Maximum Digging Reach	15.4 m	50'6"
Maximum Digging Depth	2.6 m	8'6"
Maximum Dumping Height	10.9 m	35'9"
Crowd Distance on Level	5.1 m	16'9"

Digging Forces

Maximum Crowd Force (arm cylinder)	1730 kN	388,780 lbf
Maximum Crowd Force at Ground Level (arm cylinder)	1200 kN	269,680 lbf
Maximum Breakout Force (bucket cylinder)	1200 kN	269,680 lbf

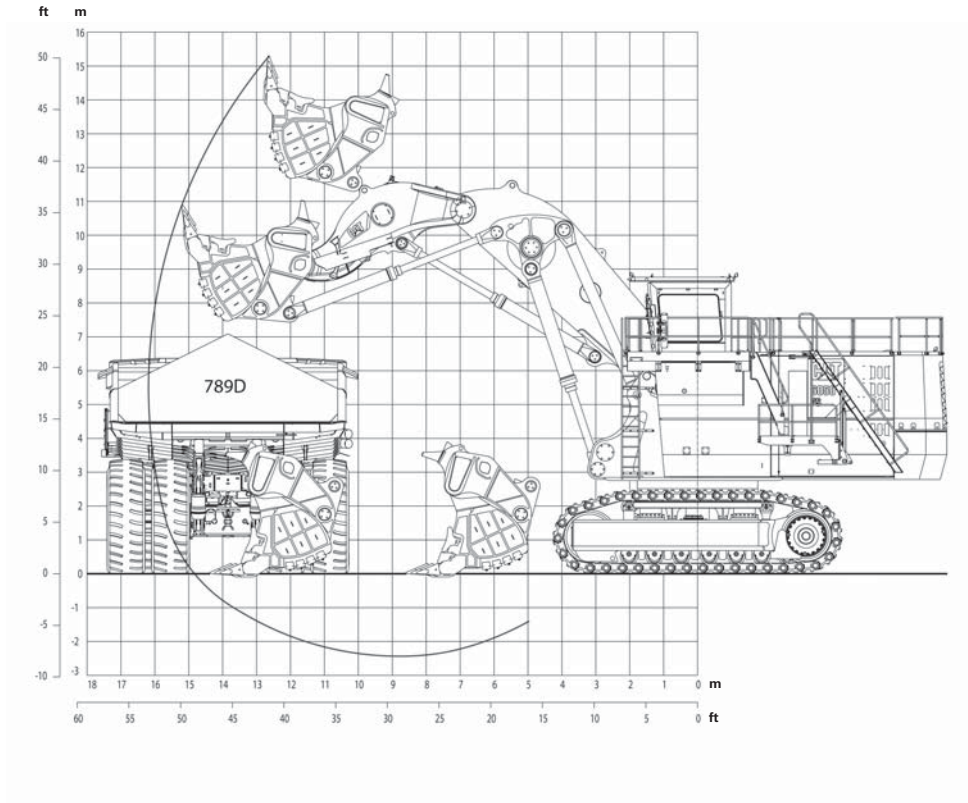

MODEL

6050 FS

Working Range

Maximum Digging Height	15.3 m	50'2"
Maximum Digging Reach	16.2 m	53'2"
Maximum Digging Depth	2.4 m	7'10"
Maximum Dumping Height	11.8 m	38'9"
Crowd Distance on Level	5.5 m	19'0"

Digging Forces

Maximum Crowd Force (arm cylinder)	1930 kN	433,730 lbf
Maximum Crowd Force at Ground Level (arm cylinder)	1650 kN	370,800 lbf
Maximum Breakout Force (bucket cylinder)	1530 kN	343,840 lbf

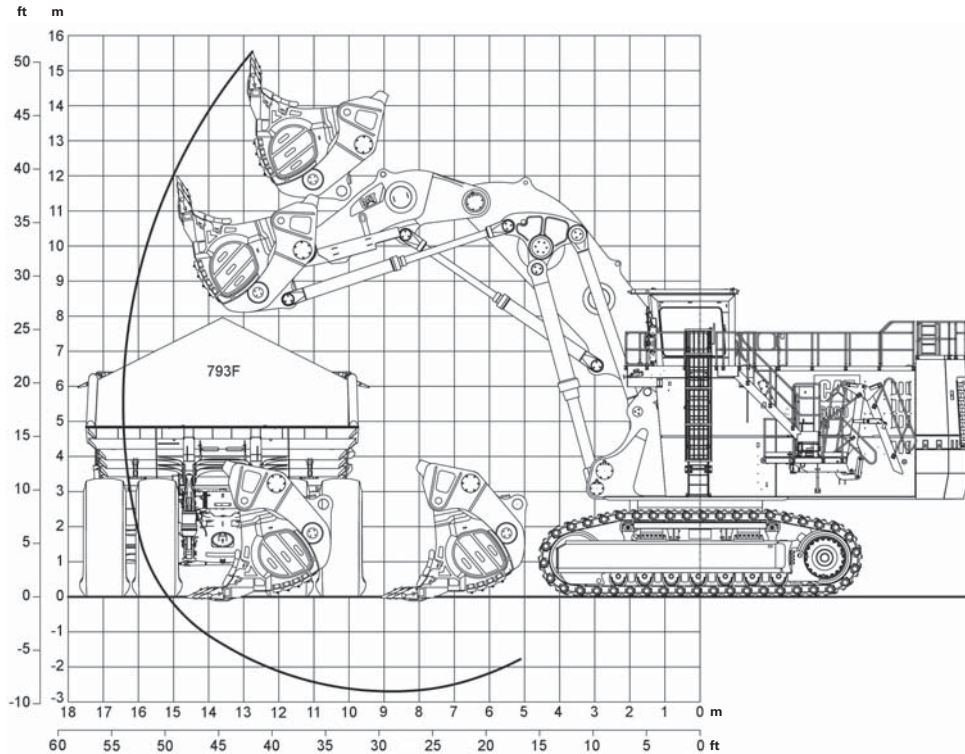

MODEL

6060 FS

Working Range

Maximum Digging Height	15.5 m	50'10"
Maximum Digging Reach	16.4 m	53'10"
Maximum Digging Depth	2.7 m	8'10"
Maximum Dumping Height	11.6 m	38'1"
Crowd Distance on Level	5.5 m	18'1"

Digging Forces

Maximum Crowd Force (arm cylinder)	2250 kN	505,640 lbf
Maximum Crowd Force at Ground Level (arm cylinder)	2100 kN	471,930 lbf
Maximum Breakout Force (bucket cylinder)	1740 kN	391,030 lbf

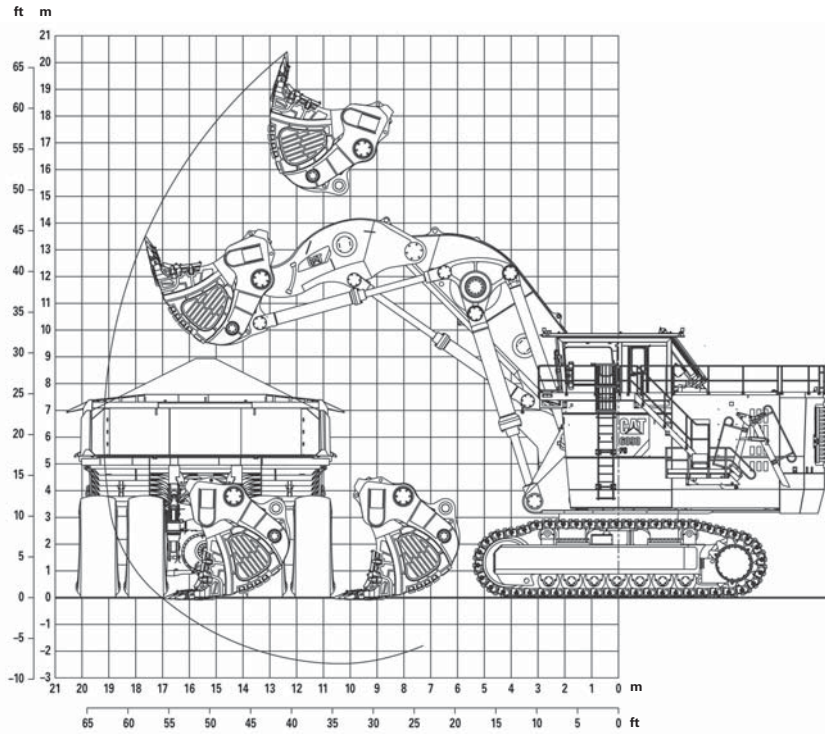

MODEL

6090 FS

Working Range

Maximum Digging Height	20.4 m	66'11"
Maximum Digging Reach	19.2 m	63'0"
Maximum Digging Depth	2.5 m	8'2"
Maximum Dumping Height	14.5 m	47'7"
Crowd Distance on Level	6.3 m	20'8"

Digging Forces

Maximum Crowd Force (arm cylinder)	3090 kN	694,420 lbf
Maximum Crowd Force at Ground Level (arm cylinder)	3080 kN	692,170 lbf
Maximum Breakout Force (bucket cylinder)	2420 kN	543,850 lbf

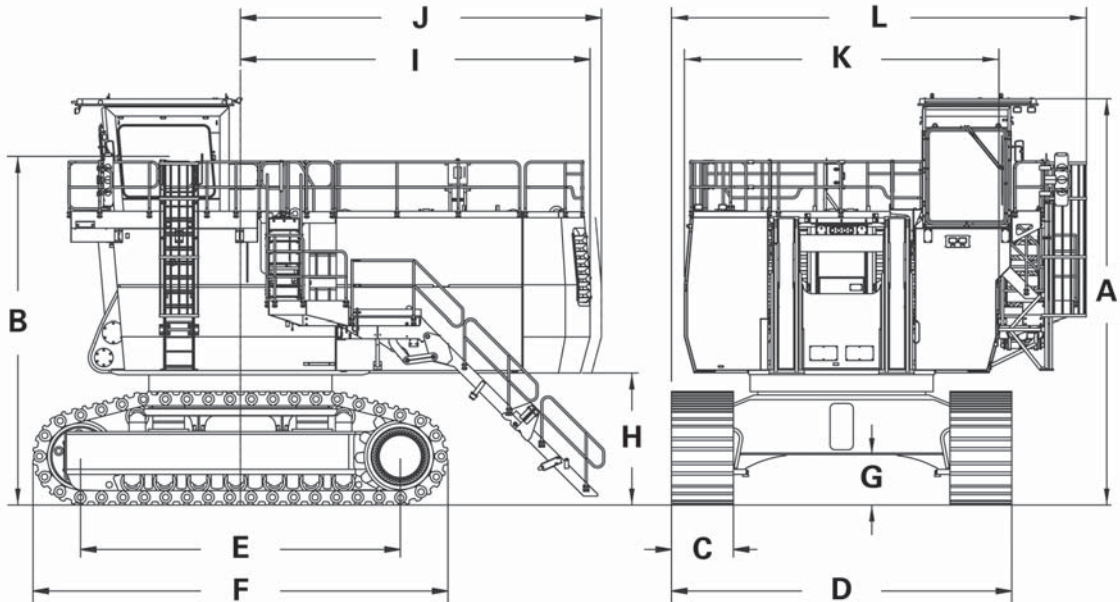

MODEL	6015/6015 FS		6018/6018 FS	
A Cab Height	5250 mm	17'3"	6560 mm	21'6"
B Operator's Eye Level, Approximate	4300 mm	14'1"	5400 mm	17'9"
C Width of Standard Track Shoe	600 mm	2'0"	800 mm	2'7"
D Track Width, Standard Shoe	4400 mm	14'5"	5300 mm	17'5"
E Track Length, Idler Center to Sprocket Center	4690 mm	15'5"	5500 mm	18'1"
F Overall Track Length, Grouser Bar to Grouser Bar	6010 mm	16'9"	7120 mm	23'4"
G Ground Clearance, Undercarriage Frame	900 mm	2'11"	1000 mm	3'3"
H Ground Clearance, Counterweight	1720 mm	5'8"	2040 mm	6'8"
I Tail Overhang	4270 mm	14'0"	5610 mm	18'5"
J Tail Swing Radius	4350 mm	14'3"	5890 mm	19'4"
K Counterweight Width	4150 mm	13'7"	5080 mm	16'8"
L Overall Width, Standard Shoe	5340 mm	17'6"	6190 mm	20'4"

NOTE: All measurements are based on the standard machine configuration.

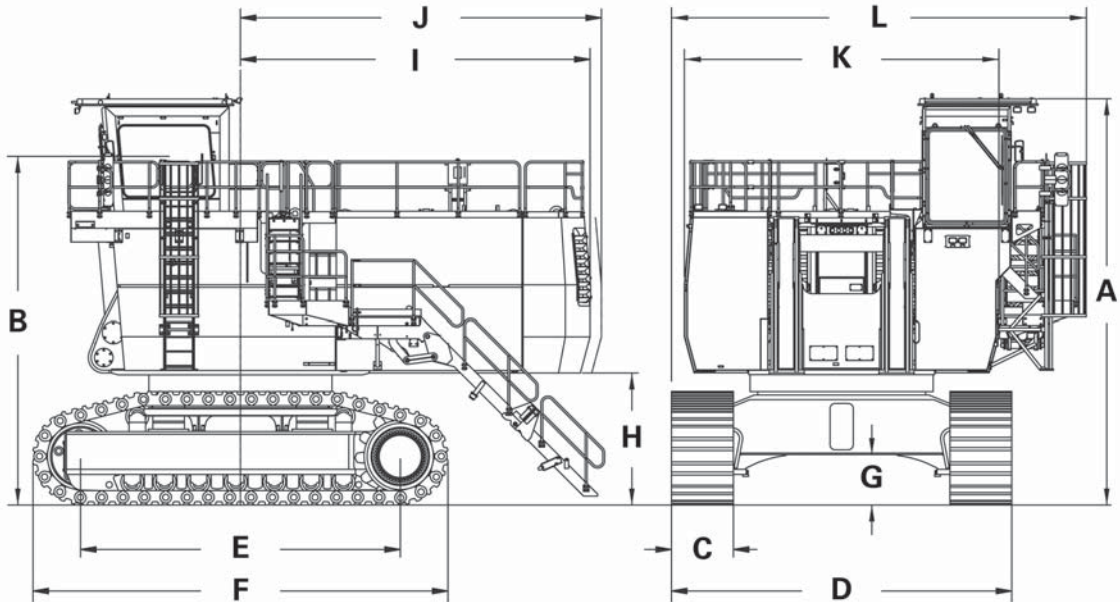

MODEL	6020B		6030/6030 FS		6040/6040 FS	
A Cab Height	6430 mm	21'1"	7620 mm	25'0"	7920 mm	26'0"
B Operator's Eye Level, Approximate	5500 mm	18'1"	6500 mm	21'4"	6780 mm	22'3"
C Width of Standard Track Shoe	800 mm	2'7"	1000 mm	3'3"	1200 mm	3'11"
D Track Width, Standard Shoe	5500 mm	18'1"	5800 mm	19'0"	6600 mm	21'8"
E Track Length, Idler Center to Sprocket Center	5810 mm	19'1"	6010 mm	19'9"	6170 mm	20'3"
F Overall Track Length, Grouser Bar to Grouser Bar	7520 mm	24'8"	7660 mm	25'2"	8090 mm	26'7"
G Ground Clearance, Undercarriage Frame	890 mm	2'11"	880 mm	2'11"	1030 mm	3'5"
H Ground Clearance, Counterweight	2095 mm	6'10"	2170 mm	7'1"	2620 mm	8'7"
I Tail Overhang	5970 mm	19'7"	6310 mm	20'8"	6780 mm	22'3"
J Tail Swing Radius	6045 mm	19'10"	6450 mm	21'2"	7000 mm	23'0"
K Counterweight Width	6240 mm	20'6"	5300 mm	17'5"	6100 mm	20'0"
L Overall Width, Standard Shoe	7850 mm	25'9"	7420 mm	24'4"	8050 mm	26'5"

NOTE: All measurements are based on the standard machine configuration.

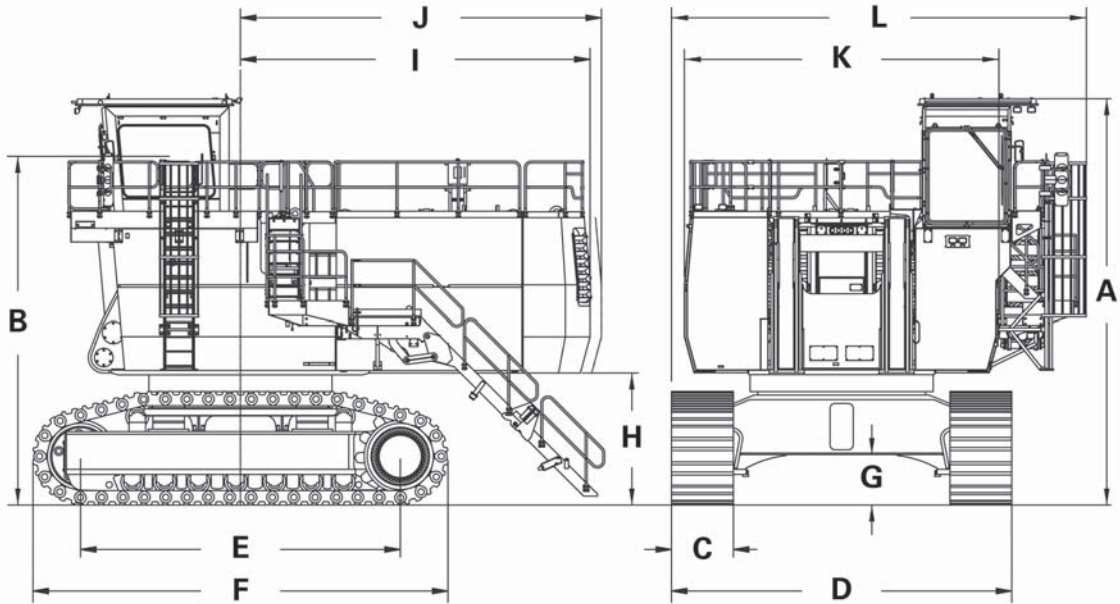

MODEL	6050/6050 FS		6060/6060 FS		6090 FS	
A Cab Height	8760 mm	28'9"	8790 mm	28'10"	9990 mm	32'9"
B Operator's Eye Level, Approximate	7600 mm	24'11"	7600 mm	24'11"	8800 mm	28'10"
C Width of Standard Track Shoe	1400 mm	4'7"	1400 mm	4'7"	2000 mm	6'7"
D Track Width, Standard Shoe	7000 mm	23'0"	7000 mm	23'0"	8600 mm	28'3"
E Track Length, Idler Center to Sprocket Center	6400 mm	21'0"	7090 mm	23'3"	8445 mm	27'8"
F Overall Track Length, Grouser Bar to Grouser Bar	8540 mm	28'0"	9230 mm	30'3"	10 980 mm	36'0"
G Ground Clearance, Undercarriage Frame	1120 mm	3'8"	1120 mm	3'8"	1135 mm	3'9"
H Ground Clearance, Counterweight	2790 mm	9'2"	2790 mm	9'2"	3150 mm	10'4"
I Tail Overhang	7350 mm	24'1"	7700 mm	25'3"	7800 mm	25'7"
J Tail Swing Radius	7580 mm	24'10"	7955 mm	26'1"	8050 mm	26'5"
K Counterweight Width	7000 mm	23'0"	7000 mm	23'0"	7600 mm	24'11"
L Overall Width, Standard Shoe	8430 mm	27'8"	8790 mm	28'10"	9720 mm	31'11"

NOTE: All measurements are based on the standard machine configuration.

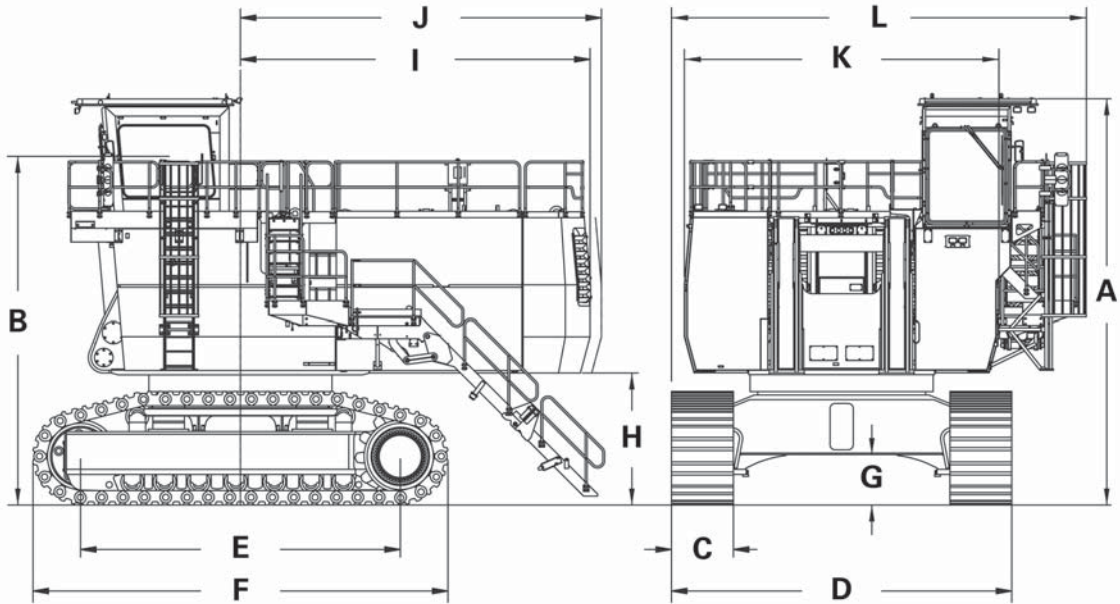

MODEL	6018 AC/ 6018 AC FS		6030 AC/ 6030 AC FS		6040 AC/ 6040 AC FS	
A Cab Height	7450 mm	24'5"	7620 mm	25'0"	7920 mm	26'0"
B Operator's Eye Level, Approximate	6300 mm	20'8"	6500 mm	21'4"	6780 mm	22'3"
C Width of Standard Track Shoe	800 mm	2'7"	1000 mm	3'3"	1200 mm	3'11"
D Track Width, Standard Shoe	5300 mm	17'5"	5800 mm	19'0"	6600 mm	21'8"
E Track Length, Idler Center to Sprocket Center	5500 mm	18'1"	5980 mm	19'7"	6170 mm	20'3"
F Overall Track Length, Grouser Bar to Grouser Bar	7120 mm	23'4"	7630 mm	25'0"	8090 mm	26'7"
G Ground Clearance, Undercarriage Frame	1000 mm	3'3"	880 mm	2'11"	1030 mm	3'5"
H Ground Clearance, Counterweight	2040 mm	6'8"	2170 mm	7'1"	2620 mm	8'7"
I Tail Overhang	5610 mm	18'5"	6310 mm	20'8"	6780 mm	22'3"
J Tail Swing Radius	5890 mm	19'4"	6450 mm	21'2"	7000 mm	23'0"
K Counterweight Width	5080 mm	16'8"	5300 mm	17'5"	6100 mm	20'0"
L Overall Width, Standard Shoe	6190 mm	20'4"	7110 mm	23'4"	7750 mm	25'5"

NOTE: All measurements are based on the standard machine configuration.

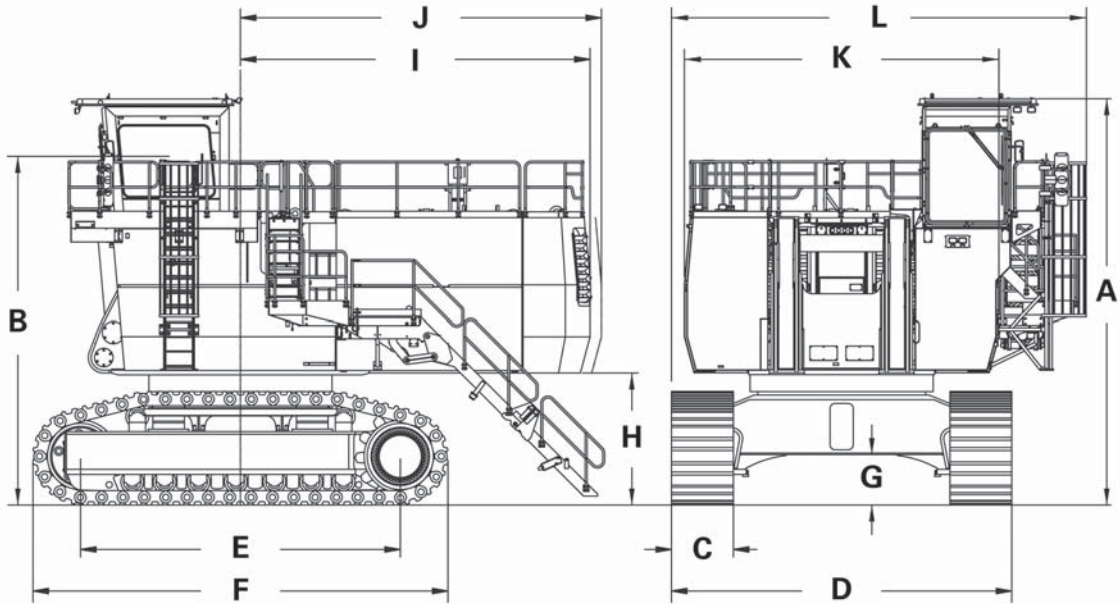

MODEL	6050 AC/ 6050 AC FS		6060 AC/ 6060 AC FS		6090 AC FS	
A Cab Height	8760 mm	28'9"	8730 mm	28'8"	9990 mm	32'9"
B Operator's Eye Level, Approximate	7600 mm	24'11"	7600 mm	24'11"	8800 mm	28'10"
C Width of Standard Track Shoe	1400 mm	4'7"	1400 mm	4'7"	2000 mm	6'7"
D Track Width, Standard Shoe	7000 mm	23'0"	7000 mm	23'0"	8600 mm	28'3"
E Track Length, Idler Center to Sprocket Center	6400 mm	21'0"	7090 mm	23'3"	8445 mm	27'8"
F Overall Track Length, Grouser Bar to Grouser Bar	8540 mm	28'0"	9230 mm	30'3"	10 980 mm	36'0"
G Ground Clearance, Undercarriage Frame	1120 mm	3'8"	1120 mm	3'8"	1135 mm	3'9"
H Ground Clearance, Counterweight	2790 mm	9'2"	2790 mm	9'2"	3150 mm	10'4"
I Tail Overhang	7350 mm	24'1"	7350 mm	24'1"	7800 mm	25'7"
J Tail Swing Radius	7580 mm	24'10"	7580 mm	24'10"	8050 mm	26'5"
K Counterweight Width	7000 mm	23'0"	7000 mm	23'0"	7600 mm	24'11"
L Overall Width, Standard Shoe	8730 mm	28'8"	8730 mm	28'8"	9720 mm	31'11"

NOTE: All measurements are based on the standard machine configuration.

GROUND PRESSURE

The ground pressure specifies the specific weight load transferred to the surface, and can be an indicator for the stability against subsidence. Though such conditions typically apply to smaller excavators in heavy earthmoving operations, there could be rare instances where this may apply in mining applications. Nevertheless, the vast majority of hydraulic mining shovels are delivered with standard track shoes.

The value is determined by setting the machine weight force in relation to the ground contact area of the tracks.

Ground Contact Area

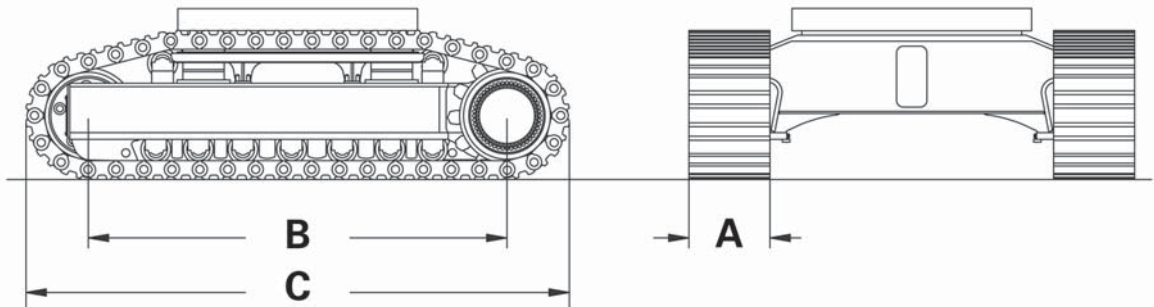

Keys

- A = Width of standard track shoe
- B = Track length, idler center to sprocket center
- C = Overall track length, grouser bar to grouser bar

To define the ground contact area on soft ground the following formula is applied:

$$2 \times A \times (B + (C - B) \times 0.35)$$

Optional Track Pads

In addition to the standard track shoes, optional track pads with different widths are available; however, these optional track pads are only procured on machine orders, and may therefore effect the lead time of the entire hydraulic mining shovel. Furthermore, a front shovel (FS) configured machine equipped with wider track pads increases the risk of track pad damage from bucket strikes.

- Backhoe Configurations
- Front Shovel Configurations

Backhoe Configurations

MODEL	Track Shoe Type	Width of Track Shoe [A]		Operating Weight		Ground Contact Area		Ground Pressure	
		mm	in	kg	lb	cm ²	in ²	N/cm ²	psi
6015	Standard	600	23.6	106 100	233,910	61 820	9580	16.6	24.1
	Option 1	750	29.5	107 500	236,990	77 280	11,980	13.5	19.5
	Option 2	900	35.4	109 000	240,300	92 740	14,370	11.4	16.5
6018	Option	600	23.6	184 000	405,650	72 800	11,280	24.8	36.0
	Standard	800	31.5	186 000	410,060	97 070	15,050	18.8	27.3
6020B	Standard	800	31.5	230 500	508,160	102 540	15,890	22.1	32.0
6030	Option 1	800	31.5	294 300	648,810	105 400	16,340	27.4	39.7
	Standard	1000	39.4	296 500	653,660	131 750	20,420	22.1	32.0
	Option 2	1200	47.2	299 500	660,280	158 100	24,510	18.6	26.9
6040	Standard	1200	47.2	407 300	897,930	164 500	25,500	24.3	35.3
	Option 1	1400	55.1	410 300	904,550	191 930	29,750	21.0	30.4
	Option 2	1600	63.0	413 300	911,160	219 340	34,000	18.5	26.7
6050	Standard	1400	55.1	537 000	1,183,870	200 180	31,030	26.3	38.1
	Option 1	1600	63.0	540 400	1,191,370	228 770	35,460	23.2	33.6
	Option 2	1800	70.9	545 900	1,203,490	257 360	39,890	20.8	30.2
6060	Standard	1400	55.1	570 300	1,257,280	219 500	34,020	25.5	37.0
	Option 1	1600	63.0	573 900	1,265,220	250 850	38,880	22.4	32.6
	Option 2	1800	70.9	579 800	1,278,230	282 200	43,740	20.2	29.2

NOTE: All measurements are based on the standard machine configuration.

NOTE: All optional track shoes are long lead items.

Front Shovel Configurations

MODEL	Track Shoe Type	Width of Track Shoe [A]		Operating Weight		Ground Contact Area		Ground Pressure	
		mm	in	kg	lb	cm ²	in ²	N/cm ²	psi
6015 FS	Standard	600	23.6	104 900	231,260	61 820	9580	16.6	24.1
	Option 1	750	29.5	106 300	234,350	77 280	11,980	13.5	19.6
	Option 2	900	35.4	107 800	237,440	92 740	14,370	11.4	16.5
6018 FS	Option	600	23.6	181 400	399,910	72 800	11,280	24.4	35.4
	Standard	800	31.5	183 400	404,320	97 070	15,050	18.5	26.9
6030 FS	Option 1	800	31.5	292 100	643,960	105 400	16,340	27.2	39.4
	Standard	1000	39.4	294 300	648,810	131 750	20,420	21.9	31.7
	Option 2	1200	47.2	297 300	655,430	158 100	24,510	18.4	26.7
6040 FS	Standard	1200	47.2	404 600	891,980	164 500	25,500	24.1	35.0
	Option 1	1400	55.1	407 600	898,590	191 930	29,750	20.8	30.2
	Option 2	1600	63.0	410 600	905,210	219 340	34,000	18.4	26.6
6050 FS	Standard	1400	55.1	527 600	1,163,150	200 180	31,030	25.9	37.5
	Option 1	1600	63.0	531 000	1,170,640	228 770	35,460	22.8	33.0
	Option 2	1800	70.9	536 500	1,182,770	257 360	39,890	20.5	29.6
6060 FS	Standard	1400	55.1	568 900	1,254,200	219 500	34,020	25.4	36.8
	Option 1	1600	63.0	572 500	1,262,130	250 850	38,880	22.4	32.4
	Option 2	1800	70.9	578 400	1,275,140	282 200	43,740	20.1	29.2
6090 FS	Option	1800	70.9	975 000	2,149,490	335 960	52,070	28.5	41.2
	Standard	2000	78.7	980 000	2,160,510	373 290	57,860	25.8	37.4

NOTE: All measurements are based on the standard machine configuration.

NOTE: All optional track shoes are long lead items.

Ground Pressures
 ● AC Units with Electric Drive
 – Backhoe Configurations
 – Front Shovel Configurations

**Hydraulic
Mining Shovels**

AC Units with Electric Drive — Backhoe Configurations

MODEL	Track Shoe Type	Width of Track Shoe [A]		Operating Weight		Ground Contact Area		Ground Pressure	
		mm	in	kg	lb	cm ²	in ²	N/cm ²	psi
6018 AC	Option	600	23.6	184 700	407,190	72 800	11,280	24.9	36.1
	Standard	800	31.5	186 700	411,600	97 070	15,050	18.9	27.3
6030 AC	Option 1	800	31.5	294 300	648,810	105 400	16,340	27.4	39.7
	Standard	1000	39.4	296 500	653,660	131 750	20,420	22.1	32.0
	Option 2	1200	47.2	299 500	660,280	158 100	24,510	18.6	26.9
6040 AC	Standard	1200	47.2	407 000	897,270	164 500	25,500	24.3	35.1
	Option 1	1400	55.1	410 000	903,890	191 930	29,750	21.0	30.4
	Option 2	1600	63.0	413 000	910,500	219 340	34,000	18.5	26.7
6050 AC	Standard	1400	55.1	524 500	1,156,310	200 180	31,030	25.7	37.3
	Option 1	1600	63.0	527 900	1,163,810	228 770	35,460	22.6	32.9
	Option 2	1800	70.9	533,400	1,175,930	257 360	39,890	20.3	29.4
6060 AC	Standard	1400	55.1	547 700	1,207,460	219 500	34,020	24.5	35.6
	Option 1	1600	63.0	551 300	1,215,400	250 850	38,880	21.6	31.3
	Option 2	1800	70.9	557 200	1,228,400	282 200	43,740	19.4	28.0

NOTE: All measurements are based on the standard machine configuration.

NOTE: All optional track shoes are long lead items.

AC Units with Electric Drive — Front Shovel Configurations

MODEL	Track Shoe Type	Width of Track Shoe [A]		Operating Weight		Ground Contact Area		Ground Pressure	
		mm	in	kg	lb	cm ²	in ²	N/cm ²	psi
6018 AC FS	Option	600	23.6	182 100	401,460	72 800	11,280	24.5	35.6
	Standard	800	31.5	184 100	405,870	97 070	15,050	18.6	27.0
6030 AC FS	Option 1	800	31.5	292 100	643,960	105 400	16,340	27.2	39.4
	Standard	1000	39.4	294 300	648,810	131 750	20,420	21.9	31.7
	Option 2	1200	47.2	297 300	655,430	158 100	24,510	18.4	26.7
6040 AC FS	Standard	1200	47.2	404 300	891,320	164 500	25,500	24.1	35.0
	Option 1	1400	55.1	407 300	897,930	191 930	29,750	20.8	30.2
	Option 2	1600	63.0	410 300	904,550	219 340	34,000	18.4	26.6
6050 AC FS	Standard	1400	55.1	515 100	1,135,590	164 500	25,500	25.2	36.6
	Option 1	1600	63.0	518 500	1,143,090	191 930	29,750	22.2	32.3
	Option 2	1800	70.9	524 000	1,155,210	219 340	34,000	20.0	29.0
6060 AC FS	Standard	1400	55.1	546 300	1,204,370	219 500	34,020	24.4	35.4
	Option 1	1600	63.0	549 900	1,212,310	250 850	38,880	21.5	31.1
	Option 2	1800	70.9	555 800	1,225,320	282 200	43,740	19.3	28.0
6090 AC FS	Option	1800	70.9	950 000	2,094,370	335 960	52,070	27.7	40.3
	Standard	2000	78.7	955 000	2,105,390	373 290	57,860	25.1	36.4

NOTE: All measurements are based on the standard machine configuration.

NOTE: All optional track shoes are long lead items.

BUCKET SELECTION

For the durability and life expectancy of hydraulic mining shovels, it is important to choose the correct bucket size based on the maximum loose density of the material to be loaded. Different bucket volumes for common material densities are available for most models. A loose density of 1.8 t/m³ (3030 lb/yd³) is considered standard density and the respective bucket volume is suitable for the majority of applications. Additional volumes are offered in staggered increments of 0.2 t/m³ (340 lb/yd³) and most of them are for heavier material.

Rated Bucket Capacity

Basically, the total volume is a combination of the struck capacity plus a heap on top of it. On hydraulic mining shovels, the rated bucket capacity is calculated with a different angle of repose for the heap of backhoe buckets versus that of face shovel buckets. As the kinematics on backhoe machines allow for larger bucket tilt angles, steeper heaps are achieved compared to face shovel buckets. Therefore, the nominal bucket capacity is calculated on backhoe buckets with a heap of 1:1, and on face shovel buckets with a heap of 2:1 as shown exemplary in the adjacent sketch.

The following standards have been used to determine the rated bucket capacity:

ISO 7451 for backhoe buckets

ISO 7546 for face shovel buckets

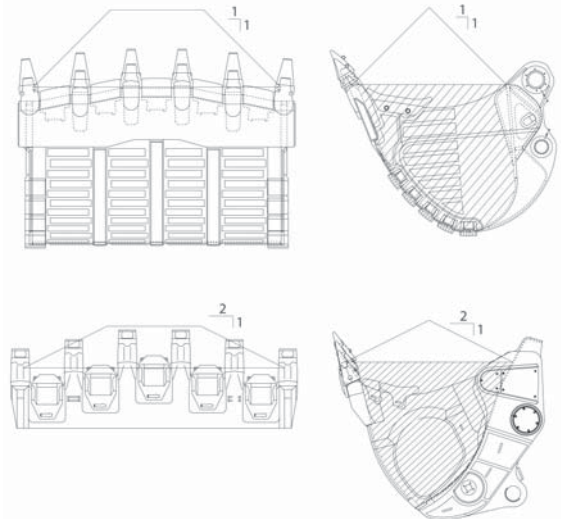

Practical Bucket Capacity

Under real working conditions, the actual achieved bucket volume, over time, is generally lower when compared to the rated capacity. This is dependent upon various factors, such as fragmentation, bench or face height and humidity. An experienced, well-trained operator achieves between 90 to 95% in reasonably blasted material.

CYCLE TIMES

The cycle time of a hydraulic mining shovel is an important productivity factor, and a key driver for high or low performance. There are two main areas that influence cycle times. One factor is the pure technical capabilities of the hydraulic mining shovel. The engine output and associated hydraulic power defines the maximum available oil flow, which consequently determines the speed of the hydraulic cylinders and swing drives, and ultimately the achievable working speed of the machine. The other factor is site specific parameters, such as operator skill, bench height (in particular for hydraulic front shovels), and swing angle, will impact cycle times considerably. Material fragmentation and penetration resistance make a big difference, as well.

Large hydraulic mining shovels are used as the prime mover in most applications. Therefore, the set-up of the loading area is pre-considered to be favorable for productive loading conditions when defining cycle times. Those are for example:

	For backhoe machines	For face shovel machines
Truck position	lower level	same level
Average swing angle	60°–90°	90°
Bench height	similar to stick length	75% of max. reach height

A complete working cycle of a hydraulic mining shovel can be separated into four segments:

- Bucket fill
- Swing loaded
- Dump
- Swing empty

However, the bucket fill process constitutes the main fraction of the loading cycle, with a portion between 40% and 50% of the total time. This is heavily influenced by the material parameters, therefore, the different cycle times, shown for each model in the attached diagram, only consider the increasing effort to fill the bucket:

- **Ideal loading conditions** — Loose material, such as dry sand, soil and gravel, or re-handled or tipped material with no effort to achieve a good fill. Bucket can penetrate anywhere in the face or pile without resistance.
- **Average loading conditions** — Soft overburden with low grade of compaction, and well-shot material with good and consistent fragmentation. Operator doesn't have to concentrate on loosening or finding the right spot for penetration.
- **Fair digging conditions** — Shot rock with partially interlocked sections, or compacted overburden, requiring some effort to loosen the material.
- **Difficult digging conditions** — Inhomogeneous shot rock with some oversized boulders and interlocking, or unblasted material. Also free digging applications in sediment type of rock with fractures and layers which allow to penetrate the material. Considerable effort required to break out material.
- **Severe digging conditions** — Poorly shot rock with a large amount of oversized boulders and/or heavily interlocked material in the majority of the face. Also free digging operations with high digging resistance. In those conditions neither cycle times nor bucket fills are predictable.

Cycle Time Estimating Chart

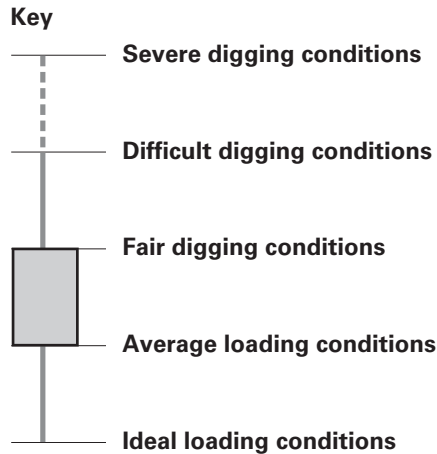
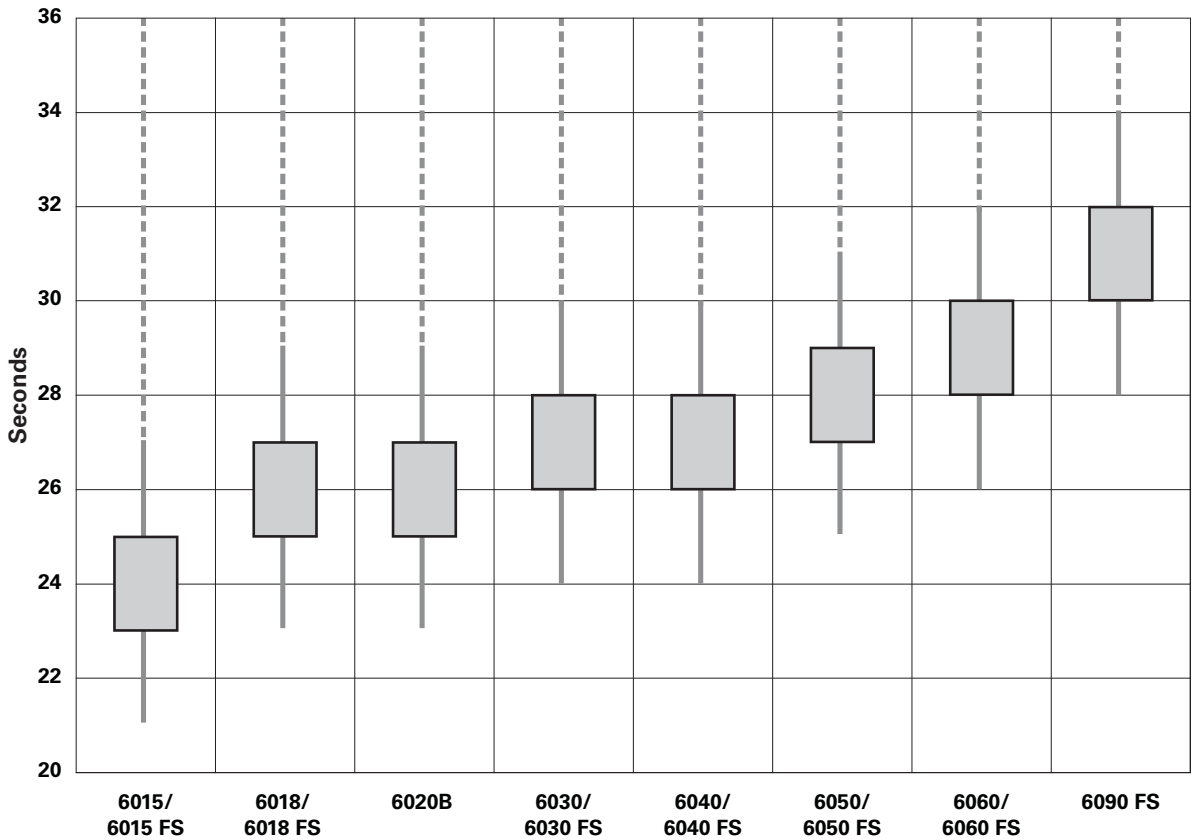

PRODUCTION OVERVIEWS

As with any other piece of material handling equipment, the productivity of a hydraulic mining shovel depends on various aspects. These influencing factors are either defined by pure machine specifications, such as bucket capacity, or by application conditions and operator skills, like bucket fill factor and cycle time. In addition, there are parameters, which fall neither under the hydraulic mining shovel's physical capabilities, nor can they be controlled by the shovel operator or the set-up of the loading area. The major factors in this category are truck spotting time and overall mine efficiency.

The following tables indicate, for a typical hydraulic mining shovel/truck combination, the wide range of productivity figures in t/h (tons/h) under various conditions. The overall mine efficiency starts at 83%, which corresponds to 50 minutes per hour. This efficiency is generally achievable only during a short period of time, and could be the relevant factor for a short time production test. However, in the long-run, the overall mine efficiency tends to be in the 65% to 75% range. The grey highlighted area illustrates average productivity figures which can be expected under typical site conditions in well organized mines.

Furthermore, the size of the truck, and the required number of passes to load it, has an effect on hydraulic mining shovel productivity. The larger the truck, the higher the hydraulic mining shovel's productivity will be, because unproductive truck spotting time will be reduced.

MODEL: 6015 Std. BH ● Bucket Size: 6.0 m³ ● Number of Cycles: 4
 ● Material Density: 1.80 t/m³ ● Average Loading Conditions

		Fill Factor	100%				95%			
		Load per Bucket	10.8 t				10.3 t			
		Load per Truck	43 t				41 t			
Overall Mine Efficiency	Truck Spotting	Cycle Time	21 sec	23 sec	25 sec	27 sec	21 sec	23 sec	25 sec	27 sec
			0.35 min	0.38 min	0.42 min	0.45 min	0.35 min	0.38 min	0.42 min	0.45 min
83% = maximum 50 min/hour	30 sec	0.50 min	1357 t/h	1274 t/h	1201 t/h	1135 t/h	1289 t/h	1211 t/h	1141 t/h	1079 t/h
	45 sec	0.75 min	1172 t/h	1110 t/h	1054 t/h	1003 t/h	1114 t/h	1054 t/h	1001 t/h	953 t/h
	60 sec	1.00 min	1032 t/h	983 t/h	939 t/h	898 t/h	980 t/h	934 t/h	892 t/h	853 t/h
	75 sec	1.25 min	921 t/h	882 t/h	846 t/h	813 t/h	875 t/h	838 t/h	804 t/h	773 t/h
80%	30 sec	0.50 min	1308 t/h	1228 t/h	1157 t/h	1094 t/h	1243 t/h	1167 t/h	1099 t/h	1040 t/h
	45 sec	0.75 min	1130 t/h	1070 t/h	1016 t/h	967 t/h	1074 t/h	1016 t/h	965 t/h	918 t/h
	60 sec	1.00 min	995 t/h	948 t/h	905 t/h	866 t/h	945 t/h	900 t/h	860 t/h	823 t/h
	75 sec	1.25 min	888 t/h	850 t/h	816 t/h	784 t/h	844 t/h	808 t/h	775 t/h	745 t/h
75%	30 sec	0.50 min	1226 t/h	1151 t/h	1085 t/h	1026 t/h	1165 t/h	1094 t/h	1031 t/h	975 t/h
	45 sec	0.75 min	1059 t/h	1003 t/h	952 t/h	906 t/h	1006 t/h	953 t/h	905 t/h	861 t/h
	60 sec	1.00 min	932 t/h	888 t/h	848 t/h	812 t/h	886 t/h	844 t/h	806 t/h	771 t/h
	75 sec	1.25 min	833 t/h	797 t/h	765 t/h	735 t/h	791 t/h	757 t/h	727 t/h	698 t/h
70%	30 sec	0.50 min	1145 t/h	1075 t/h	1013 t/h	957 t/h	1087 t/h	1021 t/h	962 t/h	910 t/h
	45 sec	0.75 min	989 t/h	936 t/h	889 t/h	846 t/h	939 t/h	889 t/h	844 t/h	804 t/h
	60 sec	1.00 min	870 t/h	829 t/h	792 t/h	758 t/h	827 t/h	788 t/h	752 t/h	720 t/h
	75 sec	1.25 min	777 t/h	744 t/h	714 t/h	686 t/h	738 t/h	707 t/h	678 t/h	652 t/h
65%	30 sec	0.50 min	1063 t/h	998 t/h	940 t/h	889 t/h	1010 t/h	948 t/h	893 t/h	845 t/h
	45 sec	0.75 min	918 t/h	869 t/h	825 t/h	785 t/h	872 t/h	826 t/h	784 t/h	746 t/h
	60 sec	1.00 min	808 t/h	770 t/h	735 t/h	703 t/h	768 t/h	731 t/h	698 t/h	668 t/h
	75 sec	1.25 min	722 t/h	691 t/h	663 t/h	637 t/h	685 t/h	656 t/h	630 t/h	605 t/h

		Fill Factor	90%				85%			
		Load per Bucket	9.7 t				9.2 t			
		Load per Truck	39 t				37 t			
Overall Mine Efficiency	Truck Spotting	Cycle Time	21 sec	23 sec	25 sec	27 sec	21 sec	23 sec	25 sec	27 sec
			0.35 min	0.38 min	0.42 min	0.45 min	0.35 min	0.38 min	0.42 min	0.45 min
83% = maximum 50 min/hour	30 sec	0.50 min	1222 t/h	1147 t/h	1081 t/h	1022 t/h	1154 t/h	1083 t/h	1021 t/h	965 t/h
	45 sec	0.75 min	1055 t/h	999 t/h	948 t/h	903 t/h	997 t/h	943 t/h	896 t/h	853 t/h
	60 sec	1.00 min	929 t/h	885 t/h	845 t/h	808 t/h	877 t/h	836 t/h	798 t/h	764 t/h
	75 sec	1.25 min	829 t/h	794 t/h	762 t/h	732 t/h	783 t/h	750 t/h	719 t/h	691 t/h
80%	30 sec	0.50 min	1177 t/h	1105 t/h	1042 t/h	985 t/h	1112 t/h	1044 t/h	984 t/h	930 t/h
	45 sec	0.75 min	1017 t/h	963 t/h	914 t/h	870 t/h	961 t/h	909 t/h	863 t/h	822 t/h
	60 sec	1.00 min	895 t/h	853 t/h	814 t/h	779 t/h	845 t/h	805 t/h	769 t/h	736 t/h
	75 sec	1.25 min	799 t/h	765 t/h	734 t/h	706 t/h	755 t/h	723 t/h	693 t/h	666 t/h
75%	30 sec	0.50 min	1104 t/h	1036 t/h	977 t/h	923 t/h	1043 t/h	979 t/h	922 t/h	872 t/h
	45 sec	0.75 min	953 t/h	903 t/h	857 t/h	816 t/h	900 t/h	852 t/h	809 t/h	770 t/h
	60 sec	1.00 min	839 t/h	800 t/h	763 t/h	731 t/h	793 t/h	755 t/h	721 t/h	690 t/h
	75 sec	1.25 min	749 t/h	718 t/h	688 t/h	661 t/h	708 t/h	678 t/h	650 t/h	625 t/h
70%	30 sec	0.50 min	1030 t/h	967 t/h	911 t/h	862 t/h	973 t/h	913 t/h	861 t/h	814 t/h
	45 sec	0.75 min	890 t/h	842 t/h	800 t/h	761 t/h	840 t/h	796 t/h	755 t/h	719 t/h
	60 sec	1.00 min	783 t/h	746 t/h	713 t/h	682 t/h	740 t/h	705 t/h	673 t/h	644 t/h
	75 sec	1.25 min	699 t/h	670 t/h	642 t/h	617 t/h	660 t/h	632 t/h	607 t/h	583 t/h
65%	30 sec	0.50 min	957 t/h	898 t/h	846 t/h	800 t/h	904 t/h	848 t/h	799 t/h	756 t/h
	45 sec	0.75 min	826 t/h	782 t/h	743 t/h	707 t/h	780 t/h	739 t/h	701 t/h	668 t/h
	60 sec	1.00 min	727 t/h	693 t/h	662 t/h	633 t/h	687 t/h	654 t/h	625 t/h	598 t/h
	75 sec	1.25 min	649 t/h	622 t/h	597 t/h	573 t/h	613 t/h	587 t/h	563 t/h	541 t/h

MODEL: 6015 Std. BH ● Bucket Size: 7.8 yd³ ● Number of Cycles: 4
● Material Density: 3030 lb/yd³ ● Average Loading Conditions

		Fill Factor	100%				95%			
		Load per Bucket	11.8 tons				11.2 tons			
		Load per Truck	47.3 tons				44.9 tons			
Overall Mine Efficiency	Cycle Time		21 sec	23 sec	25 sec	27 sec	21 sec	23 sec	25 sec	27 sec
	Truck Spotting		0.35 min	0.38 min	0.42 min	0.45 min	0.35 min	0.38 min	0.42 min	0.45 min
83% = maximum 50 min/hour	30 sec	0.50 min	1485 tons/h	1394 tons/h	1314 tons/h	1242 tons/h	1411 tons/h	1325 tons/h	1248 tons/h	1180 tons/h
	45 sec	0.75 min	1283 tons/h	1214 tons/h	1153 tons/h	1097 tons/h	1219 tons/h	1154 tons/h	1095 tons/h	1043 tons/h
	60 sec	1.00 min	1129 tons/h	1076 tons/h	1027 tons/h	983 tons/h	1073 tons/h	1022 tons/h	976 tons/h	934 tons/h
	75 sec	1.25 min	1008 tons/h	965 tons/h	926 tons/h	890 tons/h	958 tons/h	917 tons/h	880 tons/h	845 tons/h
80%	30 sec	0.50 min	1431 tons/h	1344 tons/h	1266 tons/h	1197 tons/h	1360 tons/h	1203 tons/h	1137 tons/h	
	45 sec	0.75 min	1236 tons/h	1171 tons/h	1111 tons/h	1058 tons/h	1175 tons/h	1112 tons/h	1056 tons/h	1005 tons/h
	60 sec	1.00 min	1088 tons/h	1037 tons/h	990 tons/h	947 tons/h	1034 tons/h	985 tons/h	941 tons/h	900 tons/h
	75 sec	1.25 min	972 tons/h	930 tons/h	893 tons/h	858 tons/h	923 tons/h	884 tons/h	848 tons/h	815 tons/h
75%	30 sec	0.50 min	1342 tons/h	1260 tons/h	1187 tons/h	1122 tons/h	1275 tons/h	1128 tons/h	1066 tons/h	
	45 sec	0.75 min	1159 tons/h	1097 tons/h	1042 tons/h	992 tons/h	1101 tons/h	1042 tons/h	990 tons/h	942 tons/h
	60 sec	1.00 min	1020 tons/h	972 tons/h	928 tons/h	888 tons/h	969 tons/h	923 tons/h	882 tons/h	844 tons/h
	75 sec	1.25 min	911 tons/h	872 tons/h	837 tons/h	804 tons/h	865 tons/h	829 tons/h	795 tons/h	764 tons/h
70%	30 sec	0.50 min	1253 tons/h	1176 tons/h	1108 tons/h	1048 tons/h	1190 tons/h	1117 tons/h	1053 tons/h	995 tons/h
	45 sec	0.75 min	1082 tons/h	1024 tons/h	972 tons/h	926 tons/h	1028 tons/h	973 tons/h	924 tons/h	879 tons/h
	60 sec	1.00 min	952 tons/h	907 tons/h	866 tons/h	829 tons/h	905 tons/h	862 tons/h	823 tons/h	787 tons/h
	75 sec	1.25 min	850 tons/h	814 tons/h	781 tons/h	751 tons/h	808 tons/h	773 tons/h	742 tons/h	713 tons/h
65%	30 sec	0.50 min	1163 tons/h	1092 tons/h	1029 tons/h	973 tons/h	1105 tons/h	1037 tons/h	977 tons/h	924 tons/h
	45 sec	0.75 min	1005 tons/h	951 tons/h	903 tons/h	859 tons/h	954 tons/h	903 tons/h	858 tons/h	816 tons/h
	60 sec	1.00 min	884 tons/h	842 tons/h	804 tons/h	770 tons/h	840 tons/h	800 tons/h	764 tons/h	731 tons/h
	75 sec	1.25 min	789 tons/h	756 tons/h	725 tons/h	697 tons/h	750 tons/h	718 tons/h	689 tons/h	662 tons/h

		Fill Factor	90%				85%			
		Load per Bucket	10.6 tons				10.0 tons			
		Load per Truck	42.5 tons				40.2 tons			
Overall Mine Efficiency	Cycle Time		21 sec	23 sec	25 sec	27 sec	21 sec	23 sec	25 sec	27 sec
	Truck Spotting		0.35 min	0.38 min	0.42 min	0.45 min	0.35 min	0.38 min	0.42 min	0.45 min
83% = maximum 50 min/hour	30 sec	0.50 min	1337 tons/h	1255 tons/h	1182 tons/h	1118 tons/h	1262 tons/h	1185 tons/h	1117 tons/h	1056 tons/h
	45 sec	0.75 min	1155 tons/h	1093 tons/h	1038 tons/h	988 tons/h	1090 tons/h	1032 tons/h	980 tons/h	933 tons/h
	60 sec	1.00 min	1016 tons/h	968 tons/h	924 tons/h	885 tons/h	960 tons/h	914 tons/h	873 tons/h	835 tons/h
	75 sec	1.25 min	907 tons/h	869 tons/h	834 tons/h	801 tons/h	857 tons/h	821 tons/h	787 tons/h	756 tons/h
80%	30 sec	0.50 min	1288 tons/h	1209 tons/h	1140 tons/h	1078 tons/h	1217 tons/h	1142 tons/h	1076 tons/h	1018 tons/h
	45 sec	0.75 min	1113 tons/h	1053 tons/h	1000 tons/h	952 tons/h	1051 tons/h	995 tons/h	945 tons/h	899 tons/h
	60 sec	1.00 min	979 tons/h	933 tons/h	891 tons/h	853 tons/h	925 tons/h	881 tons/h	842 tons/h	805 tons/h
	75 sec	1.25 min	875 tons/h	837 tons/h	803 tons/h	772 tons/h	826 tons/h	791 tons/h	759 tons/h	729 tons/h
75%	30 sec	0.50 min	1208 tons/h	1134 tons/h	1068 tons/h	1010 tons/h	1141 tons/h	1071 tons/h	1009 tons/h	954 tons/h
	45 sec	0.75 min	1043 tons/h	988 tons/h	938 tons/h	892 tons/h	985 tons/h	933 tons/h	886 tons/h	843 tons/h
	60 sec	1.00 min	918 tons/h	875 tons/h	835 tons/h	799 tons/h	867 tons/h	826 tons/h	789 tons/h	755 tons/h
	75 sec	1.25 min	820 tons/h	785 tons/h	753 tons/h	724 tons/h	774 tons/h	741 tons/h	711 tons/h	684 tons/h
70%	30 sec	0.50 min	1127 tons/h	1058 tons/h	997 tons/h	943 tons/h	1065 tons/h	999 tons/h	942 tons/h	890 tons/h
	45 sec	0.75 min	974 tons/h	922 tons/h	875 tons/h	833 tons/h	920 tons/h	871 tons/h	827 tons/h	787 tons/h
	60 sec	1.00 min	857 tons/h	816 tons/h	780 tons/h	746 tons/h	809 tons/h	771 tons/h	736 tons/h	705 tons/h
	75 sec	1.25 min	765 tons/h	733 tons/h	703 tons/h	676 tons/h	723 tons/h	692 tons/h	664 tons/h	638 tons/h
65%	30 sec	0.50 min	1047 tons/h	983 tons/h	926 tons/h	876 tons/h	989 tons/h	928 tons/h	875 tons/h	827 tons/h
	45 sec	0.75 min	904 tons/h	856 tons/h	813 tons/h	773 tons/h	854 tons/h	808 tons/h	767 tons/h	731 tons/h
	60 sec	1.00 min	796 tons/h	758 tons/h	724 tons/h	693 tons/h	752 tons/h	716 tons/h	684 tons/h	654 tons/h
	75 sec	1.25 min	711 tons/h	680 tons/h	653 tons/h	627 tons/h	671 tons/h	643 tons/h	616 tons/h	592 tons/h

MODEL: 6015 ME and 6015 FS ● Bucket Size: 7.0 m³ ● Number of Cycles: 4
 ● Material Density: 1.80 t/m³ ● Average Loading Conditions

		Fill Factor	100%				95%			
		Load per Bucket	12.6 t				12.0 t			
		Load per Truck	50 t				48 t			
Overall Mine Efficiency	Cycle Time		21 sec	23 sec	25 sec	27 sec	21 sec	23 sec	25 sec	27 sec
	Truck Spotting		0.35 min	0.38 min	0.42 min	0.45 min	0.35 min	0.38 min	0.42 min	0.45 min
83% = maximum 50 min/hour	30 sec	0.50 min	1584 t/h	1487 t/h	1401 t/h	1324 t/h	1504 t/h	1412 t/h	1331 t/h	1258 t/h
	45 sec	0.75 min	1368 t/h	1295 t/h	1229 t/h	1170 t/h	1299 t/h	1230 t/h	1168 t/h	1112 t/h
	60 sec	1.00 min	1204 t/h	1147 t/h	1095 t/h	1048 t/h	1144 t/h	1090 t/h	1040 t/h	996 t/h
	75 sec	1.25 min	1075 t/h	1029 t/h	988 t/h	949 t/h	1021 t/h	978 t/h	938 t/h	901 t/h
80%	30 sec	0.50 min	1526 t/h	1433 t/h	1350 t/h	1277 t/h	1450 t/h	1361 t/h	1283 t/h	1213 t/h
	45 sec	0.75 min	1318 t/h	1248 t/h	1185 t/h	1128 t/h	1252 t/h	1186 t/h	1126 t/h	1071 t/h
	60 sec	1.00 min	1160 t/h	1105 t/h	1056 t/h	1010 t/h	1102 t/h	1050 t/h	1003 t/h	960 t/h
	75 sec	1.25 min	1036 t/h	992 t/h	952 t/h	915 t/h	984 t/h	943 t/h	904 t/h	869 t/h
75%	30 sec	0.50 min	1431 t/h	1343 t/h	1266 t/h	1197 t/h	1359 t/h	1276 t/h	1203 t/h	1137 t/h
	45 sec	0.75 min	1236 t/h	1170 t/h	1111 t/h	1057 t/h	1174 t/h	1112 t/h	1055 t/h	1004 t/h
	60 sec	1.00 min	1088 t/h	1036 t/h	990 t/h	947 t/h	1033 t/h	985 t/h	940 t/h	900 t/h
	75 sec	1.25 min	971 t/h	930 t/h	892 t/h	857 t/h	923 t/h	884 t/h	848 t/h	815 t/h
70%	30 sec	0.50 min	1336 t/h	1254 t/h	1181 t/h	1117 t/h	1269 t/h	1191 t/h	1122 t/h	1061 t/h
	45 sec	0.75 min	1154 t/h	1092 t/h	1037 t/h	987 t/h	1096 t/h	1037 t/h	985 t/h	938 t/h
	60 sec	1.00 min	1015 t/h	967 t/h	924 t/h	884 t/h	964 t/h	919 t/h	878 t/h	840 t/h
	75 sec	1.25 min	907 t/h	868 t/h	833 t/h	800 t/h	861 t/h	825 t/h	791 t/h	760 t/h
65%	30 sec	0.50 min	1240 t/h	1164 t/h	1097 t/h	1037 t/h	1178 t/h	1106 t/h	1042 t/h	985 t/h
	45 sec	0.75 min	1071 t/h	1014 t/h	963 t/h	916 t/h	1018 t/h	963 t/h	915 t/h	871 t/h
	60 sec	1.00 min	943 t/h	898 t/h	858 t/h	821 t/h	896 t/h	853 t/h	815 t/h	780 t/h
	75 sec	1.25 min	842 t/h	806 t/h	773 t/h	743 t/h	800 t/h	766 t/h	735 t/h	706 t/h

		Fill Factor	90%				85%			
		Load per Bucket	11.3 t				10.7 t			
		Load per Truck	45 t				43 t			
Overall Mine Efficiency	Cycle Time		21 sec	23 sec	25 sec	27 sec	21 sec	23 sec	25 sec	27 sec
	Truck Spotting		0.35 min	0.38 min	0.42 min	0.45 min	0.35 min	0.38 min	0.42 min	0.45 min
83% = maximum 50 min/hour	30 sec	0.50 min	1425 t/h	1338 t/h	1261 t/h	1192 t/h	1346 t/h	1264 t/h	1191 t/h	1126 t/h
	45 sec	0.75 min	1231 t/h	1165 t/h	1106 t/h	1053 t/h	1163 t/h	1101 t/h	1045 t/h	995 t/h
	60 sec	1.00 min	1083 t/h	1032 t/h	986 t/h	943 t/h	1023 t/h	975 t/h	931 t/h	891 t/h
	75 sec	1.25 min	967 t/h	926 t/h	889 t/h	854 t/h	914 t/h	875 t/h	839 t/h	807 t/h
80%	30 sec	0.50 min	1374 t/h	1290 t/h	1215 t/h	1149 t/h	1297 t/h	1218 t/h	1148 t/h	1085 t/h
	45 sec	0.75 min	1187 t/h	1123 t/h	1066 t/h	1015 t/h	1121 t/h	1061 t/h	1007 t/h	959 t/h
	60 sec	1.00 min	1044 t/h	995 t/h	950 t/h	909 t/h	986 t/h	940 t/h	897 t/h	859 t/h
	75 sec	1.25 min	932 t/h	893 t/h	857 t/h	823 t/h	881 t/h	843 t/h	809 t/h	777 t/h
75%	30 sec	0.50 min	1288 t/h	1209 t/h	1139 t/h	1077 t/h	1216 t/h	1142 t/h	1076 t/h	1017 t/h
	45 sec	0.75 min	1112 t/h	1053 t/h	1000 t/h	952 t/h	1051 t/h	995 t/h	944 t/h	899 t/h
	60 sec	1.00 min	979 t/h	933 t/h	891 t/h	852 t/h	925 t/h	881 t/h	841 t/h	805 t/h
	75 sec	1.25 min	874 t/h	837 t/h	803 t/h	772 t/h	826 t/h	791 t/h	758 t/h	729 t/h
70%	30 sec	0.50 min	1202 t/h	1128 t/h	1063 t/h	1005 t/h	1135 t/h	1066 t/h	1004 t/h	949 t/h
	45 sec	0.75 min	1038 t/h	983 t/h	933 t/h	888 t/h	981 t/h	928 t/h	881 t/h	839 t/h
	60 sec	1.00 min	914 t/h	871 t/h	831 t/h	795 t/h	863 t/h	822 t/h	785 t/h	751 t/h
	75 sec	1.25 min	816 t/h	781 t/h	750 t/h	720 t/h	771 t/h	738 t/h	708 t/h	680 t/h
65%	30 sec	0.50 min	1116 t/h	1048 t/h	987 t/h	934 t/h	1054 t/h	990 t/h	933 t/h	882 t/h
	45 sec	0.75 min	964 t/h	913 t/h	866 t/h	825 t/h	910 t/h	862 t/h	818 t/h	779 t/h
	60 sec	1.00 min	848 t/h	808 t/h	772 t/h	739 t/h	801 t/h	763 t/h	729 t/h	698 t/h
	75 sec	1.25 min	758 t/h	726 t/h	696 t/h	669 t/h	716 t/h	685 t/h	657 t/h	632 t/h

MODEL: 6015 ME and 6015 FS ● Bucket Size: 9.2 yd³ ● Number of Cycles: 4
● Material Density: 3030 lb/yd³ ● Average Loading Conditions

			100%				95%			
Fill Factor			13.9 tons				13.2 tons			
Load per Bucket			55.8 tons				53.0 tons			
Load per Truck										
Overall Mine Efficiency	Cycle Time		21 sec	23 sec	25 sec	27 sec	21 sec	23 sec	25 sec	27 sec
	Truck Spotting		0.35 min	0.38 min	0.42 min	0.45 min	0.35 min	0.38 min	0.42 min	0.45 min
83% = maximum 50 min/hour	30 sec	0.50 min	1752 tons/h	1644 tons/h	1550 tons/h	1465 tons/h	1664 tons/h	1562 tons/h	1472 tons/h	1392 tons/h
	45 sec	0.75 min	1513 tons/h	1432 tons/h	1360 tons/h	1294 tons/h	1437 tons/h	1361 tons/h	1292 tons/h	1230 tons/h
	60 sec	1.00 min	1332 tons/h	1269 tons/h	1212 tons/h	1159 tons/h	1265 tons/h	1205 tons/h	1151 tons/h	1101 tons/h
	75 sec	1.25 min	1189 tons/h	1139 tons/h	1092 tons/h	1050 tons/h	1130 tons/h	1082 tons/h	1038 tons/h	997 tons/h
80%	30 sec	0.50 min	1688 tons/h	1585 tons/h	1494 tons/h	1412 tons/h	1604 tons/h	1506 tons/h	1419 tons/h	1342 tons/h
	45 sec	0.75 min	1458 tons/h	1381 tons/h	1311 tons/h	1248 tons/h	1385 tons/h	1312 tons/h	1245 tons/h	1185 tons/h
	60 sec	1.00 min	1283 tons/h	1223 tons/h	1168 tons/h	1117 tons/h	1219 tons/h	1162 tons/h	1109 tons/h	1061 tons/h
	75 sec	1.25 min	1146 tons/h	1098 tons/h	1053 tons/h	1012 tons/h	1089 tons/h	1043 tons/h	1000 tons/h	961 tons/h
75%	30 sec	0.50 min	1583 tons/h	1486 tons/h	1400 tons/h	1324 tons/h	1504 tons/h	1412 tons/h	1330 tons/h	1258 tons/h
	45 sec	0.75 min	1367 tons/h	1294 tons/h	1229 tons/h	1170 tons/h	1299 tons/h	1230 tons/h	1167 tons/h	1111 tons/h
	60 sec	1.00 min	1203 tons/h	1146 tons/h	1095 tons/h	1048 tons/h	1143 tons/h	1089 tons/h	1040 tons/h	995 tons/h
	75 sec	1.25 min	1074 tons/h	1029 tons/h	987 tons/h	949 tons/h	1021 tons/h	977 tons/h	938 tons/h	901 tons/h
70%	30 sec	0.50 min	1477 tons/h	1387 tons/h	1307 tons/h	1236 tons/h	1403 tons/h	1318 tons/h	1242 tons/h	1174 tons/h
	45 sec	0.75 min	1276 tons/h	1208 tons/h	1147 tons/h	1092 tons/h	1212 tons/h	1148 tons/h	1090 tons/h	1037 tons/h
	60 sec	1.00 min	1123 tons/h	1070 tons/h	1022 tons/h	978 tons/h	1067 tons/h	1017 tons/h	971 tons/h	929 tons/h
	75 sec	1.25 min	1003 tons/h	960 tons/h	921 tons/h	885 tons/h	953 tons/h	912 tons/h	875 tons/h	841 tons/h
65%	30 sec	0.50 min	1372 tons/h	1288 tons/h	1214 tons/h	1147 tons/h	1303 tons/h	1223 tons/h	1153 tons/h	1090 tons/h
	45 sec	0.75 min	1185 tons/h	1122 tons/h	1065 tons/h	1014 tons/h	1126 tons/h	1066 tons/h	1012 tons/h	963 tons/h
	60 sec	1.00 min	1043 tons/h	994 tons/h	949 tons/h	908 tons/h	991 tons/h	944 tons/h	901 tons/h	862 tons/h
	75 sec	1.25 min	931 tons/h	892 tons/h	855 tons/h	822 tons/h	885 tons/h	847 tons/h	813 tons/h	781 tons/h

			90%				85%			
Fill Factor			12.5 tons				11.8 tons			
Load per Bucket			50.2 tons				47.4 tons			
Load per Truck										
Overall Mine Efficiency	Cycle Time		21 sec	23 sec	25 sec	27 sec	21 sec	23 sec	25 sec	27 sec
	Truck Spotting		0.35 min	0.38 min	0.42 min	0.45 min	0.35 min	0.38 min	0.42 min	0.45 min
83% = maximum 50 min/hour	30 sec	0.50 min	1577 tons/h	1480 tons/h	1395 tons/h	1319 tons/h	1489 tons/h	1398 tons/h	1317 tons/h	1245 tons/h
	45 sec	0.75 min	1362 tons/h	1289 tons/h	1224 tons/h	1165 tons/h	1286 tons/h	1218 tons/h	1156 tons/h	1100 tons/h
	60 sec	1.00 min	1198 tons/h	1142 tons/h	1090 tons/h	1043 tons/h	1132 tons/h	1078 tons/h	1030 tons/h	985 tons/h
	75 sec	1.25 min	1070 tons/h	1025 tons/h	983 tons/h	945 tons/h	1011 tons/h	968 tons/h	929 tons/h	892 tons/h
80%	30 sec	0.50 min	1520 tons/h	1427 tons/h	1344 tons/h	1271 tons/h	1435 tons/h	1347 tons/h	1270 tons/h	1200 tons/h
	45 sec	0.75 min	1313 tons/h	1243 tons/h	1180 tons/h	1123 tons/h	1240 tons/h	1174 tons/h	1114 tons/h	1060 tons/h
	60 sec	1.00 min	1155 tons/h	1101 tons/h	1051 tons/h	1006 tons/h	1091 tons/h	1039 tons/h	993 tons/h	950 tons/h
	75 sec	1.25 min	1031 tons/h	988 tons/h	948 tons/h	911 tons/h	974 tons/h	933 tons/h	895 tons/h	860 tons/h
75%	30 sec	0.50 min	1425 tons/h	1337 tons/h	1260 tons/h	1192 tons/h	1345 tons/h	1263 tons/h	1190 tons/h	1125 tons/h
	45 sec	0.75 min	1230 tons/h	1165 tons/h	1106 tons/h	1053 tons/h	1162 tons/h	1100 tons/h	1044 tons/h	994 tons/h
	60 sec	1.00 min	1083 tons/h	1032 tons/h	985 tons/h	943 tons/h	1023 tons/h	974 tons/h	931 tons/h	890 tons/h
	75 sec	1.25 min	967 tons/h	926 tons/h	888 tons/h	854 tons/h	913 tons/h	875 tons/h	839 tons/h	806 tons/h
70%	30 sec	0.50 min	1330 tons/h	1248 tons/h	1176 tons/h	1112 tons/h	1256 tons/h	1179 tons/h	1111 tons/h	1050 tons/h
	45 sec	0.75 min	1148 tons/h	1087 tons/h	1032 tons/h	982 tons/h	1085 tons/h	1027 tons/h	975 tons/h	928 tons/h
	60 sec	1.00 min	1011 tons/h	963 tons/h	920 tons/h	880 tons/h	955 tons/h	910 tons/h	869 tons/h	831 tons/h
	75 sec	1.25 min	903 tons/h	864 tons/h	829 tons/h	797 tons/h	852 tons/h	816 tons/h	783 tons/h	752 tons/h
65%	30 sec	0.50 min	1235 tons/h	1159 tons/h	1092 tons/h	1033 tons/h	1166 tons/h	1095 tons/h	1032 tons/h	975 tons/h
	45 sec	0.75 min	1066 tons/h	1010 tons/h	958 tons/h	912 tons/h	1007 tons/h	953 tons/h	905 tons/h	862 tons/h
	60 sec	1.00 min	939 tons/h	894 tons/h	854 tons/h	817 tons/h	886 tons/h	845 tons/h	806 tons/h	772 tons/h
	75 sec	1.25 min	838 tons/h	803 tons/h	770 tons/h	740 tons/h	792 tons/h	758 tons/h	727 tons/h	699 tons/h

MODEL: 6018 and 6018 FS ● **Bucket Size: 10.0 m³** ● **Number of Cycles: 4**
 ● **Material Density: 1.80 t/m³** ● **Average Loading Conditions**

		Fill Factor		100%				95%			
		Load per Bucket		18.0 t				17.1 t			
		Load per Truck		72 t				68 t			
Overall Mine Efficiency	Truck Spotting	Cycle Time		23 sec	25 sec	27 sec	29 sec	23 sec	25 sec	27 sec	29 sec
				0.38 min	0.42 min	0.45 min	0.48 min	0.38 min	0.42 min	0.45 min	0.48 min
83% = maximum 50 min/hour	30 sec	0.50 min	2124 t/h	2001 t/h	1892 t/h	1794 t/h	2018 t/h	1901 t/h	1798 t/h	1705 t/h	
	45 sec	0.75 min	1850 t/h	1756 t/h	1672 t/h	1595 t/h	1757 t/h	1668 t/h	1588 t/h	1515 t/h	
	60 sec	1.00 min	1639 t/h	1565 t/h	1497 t/h	1435 t/h	1557 t/h	1486 t/h	1422 t/h	1363 t/h	
	75 sec	1.25 min	1471 t/h	1411 t/h	1356 t/h	1305 t/h	1397 t/h	1340 t/h	1288 t/h	1239 t/h	
80%	30 sec	0.50 min	2047 t/h	1929 t/h	1824 t/h	1729 t/h	1945 t/h	1832 t/h	1733 t/h	1643 t/h	
	45 sec	0.75 min	1783 t/h	1693 t/h	1611 t/h	1537 t/h	1694 t/h	1608 t/h	1531 t/h	1460 t/h	
	60 sec	1.00 min	1579 t/h	1508 t/h	1443 t/h	1383 t/h	1500 t/h	1433 t/h	1371 t/h	1314 t/h	
	75 sec	1.25 min	1417 t/h	1360 t/h	1307 t/h	1257 t/h	1346 t/h	1292 t/h	1241 t/h	1195 t/h	
75%	30 sec	0.50 min	1919 t/h	1808 t/h	1710 t/h	1621 t/h	1823 t/h	1718 t/h	1624 t/h	1540 t/h	
	45 sec	0.75 min	1672 t/h	1587 t/h	1510 t/h	1441 t/h	1588 t/h	1508 t/h	1435 t/h	1369 t/h	
	60 sec	1.00 min	1481 t/h	1414 t/h	1353 t/h	1297 t/h	1407 t/h	1343 t/h	1285 t/h	1232 t/h	
	75 sec	1.25 min	1329 t/h	1275 t/h	1225 t/h	1179 t/h	1262 t/h	1211 t/h	1164 t/h	1120 t/h	
70%	30 sec	0.50 min	1791 t/h	1688 t/h	1596 t/h	1513 t/h	1702 t/h	1603 t/h	1516 t/h	1438 t/h	
	45 sec	0.75 min	1560 t/h	1481 t/h	1410 t/h	1345 t/h	1482 t/h	1407 t/h	1339 t/h	1278 t/h	
	60 sec	1.00 min	1382 t/h	1320 t/h	1263 t/h	1210 t/h	1313 t/h	1254 t/h	1199 t/h	1150 t/h	
	75 sec	1.25 min	1240 t/h	1190 t/h	1143 t/h	1100 t/h	1178 t/h	1128 t/h	1086 t/h	1045 t/h	
65%	30 sec	0.50 min	1663 t/h	1567 t/h	1482 t/h	1405 t/h	1580 t/h	1489 t/h	1408 t/h	1335 t/h	
	45 sec	0.75 min	1449 t/h	1375 t/h	1309 t/h	1249 t/h	1376 t/h	1307 t/h	1244 t/h	1186 t/h	
	60 sec	1.00 min	1283 t/h	1225 t/h	1172 t/h	1124 t/h	1219 t/h	1164 t/h	1114 t/h	1068 t/h	
	75 sec	1.25 min	1152 t/h	1105 t/h	1062 t/h	1022 t/h	1094 t/h	1050 t/h	1009 t/h	971 t/h	

		Fill Factor		90%				85%			
		Load per Bucket		16.2 t				15.3 t			
		Load per Truck		65 t				61 t			
Overall Mine Efficiency	Truck Spotting	Cycle Time		23 sec	25 sec	27 sec	29 sec	23 sec	25 sec	27 sec	29 sec
				0.38 min	0.42 min	0.45 min	0.48 min	0.38 min	0.42 min	0.45 min	0.48 min
83% = maximum 50 min/hour	30 sec	0.50 min	1911 t/h	1801 t/h	1703 t/h	1615 t/h	1805 t/h	1701 t/h	1608 t/h	1525 t/h	
	45 sec	0.75 min	1665 t/h	1581 t/h	1504 t/h	1435 t/h	1572 t/h	1493 t/h	1421 t/h	1356 t/h	
	60 sec	1.00 min	1475 t/h	1408 t/h	1347 t/h	1292 t/h	1393 t/h	1330 t/h	1273 t/h	1220 t/h	
	75 sec	1.25 min	1323 t/h	1270 t/h	1220 t/h	1174 t/h	1250 t/h	1199 t/h	1152 t/h	1109 t/h	
80%	30 sec	0.50 min	1842 t/h	1736 t/h	1641 t/h	1556 t/h	1740 t/h	1640 t/h	1550 t/h	1470 t/h	
	45 sec	0.75 min	1605 t/h	1523 t/h	1450 t/h	1383 t/h	1516 t/h	1439 t/h	1370 t/h	1307 t/h	
	60 sec	1.00 min	1421 t/h	1357 t/h	1299 t/h	1245 t/h	1342 t/h	1282 t/h	1227 t/h	1176 t/h	
	75 sec	1.25 min	1276 t/h	1224 t/h	1176 t/h	1132 t/h	1205 t/h	1156 t/h	1111 t/h	1069 t/h	
75%	30 sec	0.50 min	1727 t/h	1628 t/h	1539 t/h	1459 t/h	1631 t/h	1537 t/h	1453 t/h	1378 t/h	
	45 sec	0.75 min	1504 t/h	1428 t/h	1359 t/h	1297 t/h	1421 t/h	1349 t/h	1284 t/h	1225 t/h	
	60 sec	1.00 min	1333 t/h	1272 t/h	1218 t/h	1167 t/h	1258 t/h	1202 t/h	1150 t/h	1102 t/h	
	75 sec	1.25 min	1196 t/h	1147 t/h	1102 t/h	1061 t/h	1129 t/h	1084 t/h	1041 t/h	1002 t/h	
70%	30 sec	0.50 min	1612 t/h	1519 t/h	1436 t/h	1362 t/h	1522 t/h	1435 t/h	1356 t/h	1286 t/h	
	45 sec	0.75 min	1404 t/h	1333 t/h	1269 t/h	1210 t/h	1326 t/h	1259 t/h	1198 t/h	1143 t/h	
	60 sec	1.00 min	1244 t/h	1188 t/h	1136 t/h	1089 t/h	1175 t/h	1122 t/h	1073 t/h	1029 t/h	
	75 sec	1.25 min	1116 t/h	1071 t/h	1029 t/h	990 t/h	1054 t/h	1011 t/h	972 t/h	935 t/h	
65%	30 sec	0.50 min	1497 t/h	1411 t/h	1334 t/h	1265 t/h	1414 t/h	1332 t/h	1260 t/h	1194 t/h	
	45 sec	0.75 min	1304 t/h	1238 t/h	1178 t/h	1124 t/h	1231 t/h	1169 t/h	1113 t/h	1062 t/h	
	60 sec	1.00 min	1155 t/h	1103 t/h	1055 t/h	1012 t/h	1091 t/h	1042 t/h	997 t/h	955 t/h	
	75 sec	1.25 min	1036 t/h	994 t/h	955 t/h	920 t/h	979 t/h	939 t/h	902 t/h	868 t/h	

MODEL: 6018 and 6018 FS ● Bucket Size: 13.1 yd³ ● Number of Cycles: 4
● Material Density: 3030 lb/yd³ ● Average Loading Conditions

			100%				95%			
Fill Factor			19.8 tons				18.9 tons			
Load per Bucket			79.4 tons				75.4 tons			
Load per Truck										
Overall Mine Efficiency	Cycle Time		23 sec	25 sec	27 sec	29 sec	23 sec	25 sec	27 sec	29 sec
	Truck Spotting		0.38 min	0.42 min	0.45 min	0.48 min	0.38 min	0.42 min	0.45 min	0.48 min
83% = maximum 50 min/hour	30 sec	0.50 min	2342 tons/h	2207 tons/h	2086 tons/h	1978 tons/h	2225 tons/h	2096 tons/h	1982 tons/h	1879 tons/h
	45 sec	0.75 min	2040 tons/h	1936 tons/h	1843 tons/h	1758 tons/h	1938 tons/h	1840 tons/h	1751 tons/h	1670 tons/h
	60 sec	1.00 min	1807 tons/h	1725 tons/h	1651 tons/h	1582 tons/h	1716 tons/h	1639 tons/h	1568 tons/h	1503 tons/h
	75 sec	1.25 min	1621 tons/h	1555 tons/h	1495 tons/h	1438 tons/h	1540 tons/h	1478 tons/h	1420 tons/h	1367 tons/h
80%	30 sec	0.50 min	2257 tons/h	2127 tons/h	2011 tons/h	1907 tons/h	2144 tons/h	2020 tons/h	1910 tons/h	1812 tons/h
	45 sec	0.75 min	1966 tons/h	1866 tons/h	1776 tons/h	1695 tons/h	1868 tons/h	1773 tons/h	1688 tons/h	1610 tons/h
	60 sec	1.00 min	1741 tons/h	1663 tons/h	1591 tons/h	1525 tons/h	1654 tons/h	1580 tons/h	1511 tons/h	1449 tons/h
	75 sec	1.25 min	1563 tons/h	1499 tons/h	1441 tons/h	1386 tons/h	1485 tons/h	1424 tons/h	1369 tons/h	1317 tons/h
75%	30 sec	0.50 min	2116 tons/h	1994 tons/h	1885 tons/h	1788 tons/h	2010 tons/h	1894 tons/h	1791 tons/h	1698 tons/h
	45 sec	0.75 min	1843 tons/h	1750 tons/h	1665 tons/h	1589 tons/h	1751 tons/h	1662 tons/h	1582 tons/h	1509 tons/h
	60 sec	1.00 min	1632 tons/h	1559 tons/h	1492 tons/h	1430 tons/h	1551 tons/h	1481 tons/h	1417 tons/h	1358 tons/h
	75 sec	1.25 min	1465 tons/h	1406 tons/h	1351 tons/h	1300 tons/h	1392 tons/h	1335 tons/h	1283 tons/h	1235 tons/h
70%	30 sec	0.50 min	1975 tons/h	1861 tons/h	1759 tons/h	1668 tons/h	1876 tons/h	1768 tons/h	1672 tons/h	1585 tons/h
	45 sec	0.75 min	1720 tons/h	1633 tons/h	1554 tons/h	1483 tons/h	1634 tons/h	1551 tons/h	1477 tons/h	1409 tons/h
	60 sec	1.00 min	1524 tons/h	1455 tons/h	1392 tons/h	1335 tons/h	1447 tons/h	1382 tons/h	1323 tons/h	1268 tons/h
	75 sec	1.25 min	1367 tons/h	1312 tons/h	1261 tons/h	1213 tons/h	1299 tons/h	1242 tons/h	1198 tons/h	1153 tons/h
65%	30 sec	0.50 min	1834 tons/h	1728 tons/h	1634 tons/h	1549 tons/h	1742 tons/h	1642 tons/h	1552 tons/h	1472 tons/h
	45 sec	0.75 min	1597 tons/h	1516 tons/h	1443 tons/h	1377 tons/h	1517 tons/h	1441 tons/h	1371 tons/h	1308 tons/h
	60 sec	1.00 min	1415 tons/h	1351 tons/h	1293 tons/h	1239 tons/h	1344 tons/h	1283 tons/h	1228 tons/h	1177 tons/h
	75 sec	1.25 min	1270 tons/h	1218 tons/h	1171 tons/h	1127 tons/h	1206 tons/h	1157 tons/h	1112 tons/h	1070 tons/h

			90%				85%			
Fill Factor			17.9 tons				16.9 tons			
Load per Bucket			71.4 tons				67.5 tons			
Load per Truck										
Overall Mine Efficiency	Cycle Time		23 sec	25 sec	27 sec	29 sec	23 sec	25 sec	27 sec	29 sec
	Truck Spotting		0.38 min	0.42 min	0.45 min	0.48 min	0.38 min	0.42 min	0.45 min	0.48 min
83% = maximum 50 min/hour	30 sec	0.50 min	2107 tons/h	1986 tons/h	1878 tons/h	1781 tons/h	1990 tons/h	1876 tons/h	1773 tons/h	1682 tons/h
	45 sec	0.75 min	1836 tons/h	1743 tons/h	1659 tons/h	1583 tons/h	1734 tons/h	1646 tons/h	1567 tons/h	1495 tons/h
	60 sec	1.00 min	1626 tons/h	1553 tons/h	1486 tons/h	1424 tons/h	1536 tons/h	1466 tons/h	1403 tons/h	1345 tons/h
	75 sec	1.25 min	1459 tons/h	1400 tons/h	1345 tons/h	1295 tons/h	1378 tons/h	1322 tons/h	1270 tons/h	1223 tons/h
80%	30 sec	0.50 min	2031 tons/h	1914 tons/h	1810 tons/h	1716 tons/h	1918 tons/h	1808 tons/h	1709 tons/h	1621 tons/h
	45 sec	0.75 min	1769 tons/h	1680 tons/h	1599 tons/h	1525 tons/h	1671 tons/h	1586 tons/h	1510 tons/h	1441 tons/h
	60 sec	1.00 min	1567 tons/h	1496 tons/h	1432 tons/h	1373 tons/h	1480 tons/h	1413 tons/h	1352 tons/h	1296 tons/h
	75 sec	1.25 min	1406 tons/h	1349 tons/h	1297 tons/h	1248 tons/h	1328 tons/h	1274 tons/h	1225 tons/h	1179 tons/h
75%	30 sec	0.50 min	1904 tons/h	1794 tons/h	1697 tons/h	1609 tons/h	1799 tons/h	1695 tons/h	1602 tons/h	1520 tons/h
	45 sec	0.75 min	1659 tons/h	1575 tons/h	1499 tons/h	1430 tons/h	1567 tons/h	1487 tons/h	1416 tons/h	1351 tons/h
	60 sec	1.00 min	1469 tons/h	1403 tons/h	1342 tons/h	1287 tons/h	1388 tons/h	1325 tons/h	1268 tons/h	1215 tons/h
	75 sec	1.25 min	1319 tons/h	1265 tons/h	1216 tons/h	1170 tons/h	1245 tons/h	1195 tons/h	1148 tons/h	1105 tons/h
70%	30 sec	0.50 min	1777 tons/h	1675 tons/h	1584 tons/h	1502 tons/h	1679 tons/h	1582 tons/h	1496 tons/h	1418 tons/h
	45 sec	0.75 min	1548 tons/h	1470 tons/h	1399 tons/h	1335 tons/h	1462 tons/h	1388 tons/h	1321 tons/h	1261 tons/h
	60 sec	1.00 min	1371 tons/h	1309 tons/h	1253 tons/h	1201 tons/h	1295 tons/h	1237 tons/h	1183 tons/h	1134 tons/h
	75 sec	1.25 min	1231 tons/h	1181 tons/h	1135 tons/h	1092 tons/h	1162 tons/h	1115 tons/h	1071 tons/h	1031 tons/h
65%	30 sec	0.50 min	1650 tons/h	1555 tons/h	1470 tons/h	1394 tons/h	1559 tons/h	1469 tons/h	1389 tons/h	1317 tons/h
	45 sec	0.75 min	1438 tons/h	1365 tons/h	1299 tons/h	1239 tons/h	1358 tons/h	1289 tons/h	1227 tons/h	1170 tons/h
	60 sec	1.00 min	1273 tons/h	1216 tons/h	1163 tons/h	1115 tons/h	1203 tons/h	1148 tons/h	1099 tons/h	1053 tons/h
	75 sec	1.25 min	1143 tons/h	1096 tons/h	1053 tons/h	1014 tons/h	1079 tons/h	1035 tons/h	995 tons/h	958 tons/h

MODEL: 6020B ● Bucket Size: 12.0 m³ ● Number of Cycles: 4
● Material Density: 1.80 t/m³ ● Average Loading Conditions

		Fill Factor		100%				95%			
		Load per Bucket		21.6 t				20.5 t			
		Load per Truck		86 t				82 t			
Overall Mine Efficiency	Truck Spotting	Cycle Time		23 sec	25 sec	27 sec	29 sec	23 sec	25 sec	27 sec	29 sec
		30 sec	0.50 min	0.38 min	0.42 min	0.45 min	0.48 min	0.38 min	0.42 min	0.45 min	0.48 min
83% = maximum 50 min/hour	30 sec	0.50 min	2549 t/h	2402 t/h	2271 t/h	2153 t/h	2421 t/h	2281 t/h	2157 t/h	2045 t/h	
	45 sec	0.75 min	2220 t/h	2107 t/h	2006 t/h	1914 t/h	2109 t/h	2002 t/h	1906 t/h	1818 t/h	
	60 sec	1.00 min	1966 t/h	1878 t/h	1797 t/h	1722 t/h	1868 t/h	1784 t/h	1707 t/h	1636 t/h	
	75 sec	1.25 min	1765 t/h	1693 t/h	1627 t/h	1566 t/h	1676 t/h	1608 t/h	1545 t/h	1487 t/h	
80%	30 sec	0.50 min	2456 t/h	2315 t/h	2188 t/h	2075 t/h	2334 t/h	2199 t/h	2079 t/h	1972 t/h	
	45 sec	0.75 min	2140 t/h	2031 t/h	1933 t/h	1845 t/h	2033 t/h	1930 t/h	1837 t/h	1752 t/h	
	60 sec	1.00 min	1895 t/h	1810 t/h	1732 t/h	1660 t/h	1800 t/h	1719 t/h	1645 t/h	1577 t/h	
	75 sec	1.25 min	1701 t/h	1632 t/h	1568 t/h	1509 t/h	1616 t/h	1550 t/h	1490 t/h	1434 t/h	
75%	30 sec	0.50 min	2303 t/h	2170 t/h	2052 t/h	1946 t/h	2188 t/h	2062 t/h	1949 t/h	1848 t/h	
	45 sec	0.75 min	2006 t/h	1904 t/h	1813 t/h	1729 t/h	1906 t/h	1809 t/h	1722 t/h	1643 t/h	
	60 sec	1.00 min	1777 t/h	1697 t/h	1623 t/h	1556 t/h	1688 t/h	1612 t/h	1542 t/h	1478 t/h	
	75 sec	1.25 min	1595 t/h	1530 t/h	1470 t/h	1415 t/h	1515 t/h	1453 t/h	1396 t/h	1344 t/h	
70%	30 sec	0.50 min	2149 t/h	2025 t/h	1915 t/h	1816 t/h	2042 t/h	1924 t/h	1819 t/h	1725 t/h	
	45 sec	0.75 min	1872 t/h	1777 t/h	1692 t/h	1614 t/h	1779 t/h	1689 t/h	1607 t/h	1533 t/h	
	60 sec	1.00 min	1658 t/h	1583 t/h	1515 t/h	1452 t/h	1575 t/h	1504 t/h	1439 t/h	1380 t/h	
	75 sec	1.25 min	1488 t/h	1428 t/h	1372 t/h	1320 t/h	1414 t/h	1356 t/h	1303 t/h	1254 t/h	
65%	30 sec	0.50 min	1996 t/h	1881 t/h	1778 t/h	1686 t/h	1896 t/h	1787 t/h	1689 t/h	1602 t/h	
	45 sec	0.75 min	1738 t/h	1650 t/h	1571 t/h	1499 t/h	1651 t/h	1568 t/h	1492 t/h	1424 t/h	
	60 sec	1.00 min	1540 t/h	1470 t/h	1407 t/h	1349 t/h	1463 t/h	1397 t/h	1337 t/h	1281 t/h	
	75 sec	1.25 min	1382 t/h	1326 t/h	1274 t/h	1226 t/h	1313 t/h	1259 t/h	1210 t/h	1165 t/h	

		Fill Factor		90%				85%			
		Load per Bucket		19.4 t				18.4 t			
		Load per Truck		78 t				73 t			
Overall Mine Efficiency	Truck Spotting	Cycle Time		23 sec	25 sec	27 sec	29 sec	23 sec	25 sec	27 sec	29 sec
		30 sec	0.50 min	0.38 min	0.42 min	0.45 min	0.48 min	0.38 min	0.42 min	0.45 min	0.48 min
83% = maximum 50 min/hour	30 sec	0.50 min	2294 t/h	2161 t/h	2044 t/h	1938 t/h	2166 t/h	2041 t/h	1930 t/h	1830 t/h	
	45 sec	0.75 min	1998 t/h	1897 t/h	1805 t/h	1722 t/h	1887 t/h	1791 t/h	1705 t/h	1627 t/h	
	60 sec	1.00 min	1770 t/h	1690 t/h	1617 t/h	1550 t/h	1671 t/h	1596 t/h	1527 t/h	1464 t/h	
	75 sec	1.25 min	1588 t/h	1524 t/h	1464 t/h	1409 t/h	1500 t/h	1439 t/h	1383 t/h	1331 t/h	
80%	30 sec	0.50 min	2211 t/h	2083 t/h	1970 t/h	1868 t/h	2088 t/h	1968 t/h	1860 t/h	1764 t/h	
	45 sec	0.75 min	1926 t/h	1828 t/h	1740 t/h	1660 t/h	1819 t/h	1727 t/h	1643 t/h	1568 t/h	
	60 sec	1.00 min	1706 t/h	1629 t/h	1558 t/h	1494 t/h	1611 t/h	1538 t/h	1472 t/h	1411 t/h	
	75 sec	1.25 min	1531 t/h	1469 t/h	1411 t/h	1358 t/h	1446 t/h	1387 t/h	1333 t/h	1283 t/h	
75%	30 sec	0.50 min	2073 t/h	1953 t/h	1847 t/h	1751 t/h	1957 t/h	1845 t/h	1744 t/h	1654 t/h	
	45 sec	0.75 min	1805 t/h	1714 t/h	1631 t/h	1556 t/h	1705 t/h	1619 t/h	1541 t/h	1470 t/h	
	60 sec	1.00 min	1599 t/h	1527 t/h	1461 t/h	1401 t/h	1510 t/h	1442 t/h	1380 t/h	1323 t/h	
	75 sec	1.25 min	1435 t/h	1377 t/h	1323 t/h	1273 t/h	1355 t/h	1300 t/h	1249 t/h	1202 t/h	
70%	30 sec	0.50 min	1934 t/h	1823 t/h	1723 t/h	1634 t/h	1827 t/h	1722 t/h	1628 t/h	1544 t/h	
	45 sec	0.75 min	1685 t/h	1600 t/h	1523 t/h	1453 t/h	1591 t/h	1511 t/h	1438 t/h	1372 t/h	
	60 sec	1.00 min	1492 t/h	1425 t/h	1364 t/h	1307 t/h	1410 t/h	1346 t/h	1288 t/h	1235 t/h	
	75 sec	1.25 min	1339 t/h	1285 t/h	1235 t/h	1188 t/h	1265 t/h	1214 t/h	1166 t/h	1122 t/h	
65%	30 sec	0.50 min	1796 t/h	1693 t/h	1600 t/h	1518 t/h	1696 t/h	1599 t/h	1511 t/h	1433 t/h	
	45 sec	0.75 min	1565 t/h	1485 t/h	1414 t/h	1349 t/h	1478 t/h	1403 t/h	1335 t/h	1274 t/h	
	60 sec	1.00 min	1386 t/h	1323 t/h	1266 t/h	1214 t/h	1309 t/h	1250 t/h	1196 t/h	1146 t/h	
	75 sec	1.25 min	1244 t/h	1193 t/h	1147 t/h	1103 t/h	1175 t/h	1127 t/h	1083 t/h	1042 t/h	

MODEL: 6020B ● Bucket Size: 15.7 yd³ ● Number of Cycles: 4
● Material Density: 3030 lb/yd³ ● Average Loading Conditions

		Fill Factor		100%				95%			
		Load per Bucket		23.8 tons				22.6 tons			
		Load per Truck		95.1 tons				90.4 tons			
Overall Mine Efficiency	Cycle Time		23 sec	25 sec	27 sec	29 sec	23 sec	25 sec	27 sec	29 sec	
	Truck Spotting		0.38 min	0.42 min	0.45 min	0.48 min	0.38 min	0.42 min	0.45 min	0.48 min	
83% = maximum 50 min/hour	30 sec	0.50 min	2809 tons/h	2647 tons/h	2503 tons/h	2373 tons/h	2669 tons/h	2515 tons/h	2378 tons/h	2255 tons/h	
	45 sec	0.75 min	2447 tons/h	2323 tons/h	2211 tons/h	2110 tons/h	2325 tons/h	2207 tons/h	2101 tons/h	2004 tons/h	
	60 sec	1.00 min	2167 tons/h	2070 tons/h	1980 tons/h	1898 tons/h	2059 tons/h	1966 tons/h	1881 tons/h	1803 tons/h	
	75 sec	1.25 min	1945 tons/h	1866 tons/h	1793 tons/h	1726 tons/h	1848 tons/h	1773 tons/h	1703 tons/h	1639 tons/h	
80%	30 sec	0.50 min	2708 tons/h	2552 tons/h	2412 tons/h	2288 tons/h	2572 tons/h	2424 tons/h	2292 tons/h	2173 tons/h	
	45 sec	0.75 min	2358 tons/h	2239 tons/h	2131 tons/h	2033 tons/h	2241 tons/h	2127 tons/h	2025 tons/h	1932 tons/h	
	60 sec	1.00 min	2089 tons/h	1995 tons/h	1909 tons/h	1830 tons/h	1985 tons/h	1895 tons/h	1813 tons/h	1738 tons/h	
	75 sec	1.25 min	1875 tons/h	1799 tons/h	1728 tons/h	1663 tons/h	1781 tons/h	1709 tons/h	1642 tons/h	1580 tons/h	
75%	30 sec	0.50 min	2538 tons/h	2392 tons/h	2262 tons/h	2145 tons/h	2412 tons/h	2272 tons/h	2149 tons/h	2037 tons/h	
	45 sec	0.75 min	2211 tons/h	2099 tons/h	1998 tons/h	1906 tons/h	2100 tons/h	1994 tons/h	1898 tons/h	1811 tons/h	
	60 sec	1.00 min	1958 tons/h	1870 tons/h	1789 tons/h	1715 tons/h	1861 tons/h	1777 tons/h	1700 tons/h	1630 tons/h	
	75 sec	1.25 min	1758 tons/h	1686 tons/h	1620 tons/h	1559 tons/h	1670 tons/h	1602 tons/h	1539 tons/h	1481 tons/h	
70%	30 sec	0.50 min	2369 tons/h	2233 tons/h	2111 tons/h	2002 tons/h	2251 tons/h	2121 tons/h	2005 tons/h	1902 tons/h	
	45 sec	0.75 min	2064 tons/h	1959 tons/h	1865 tons/h	1779 tons/h	1960 tons/h	1861 tons/h	1772 tons/h	1690 tons/h	
	60 sec	1.00 min	1828 tons/h	1745 tons/h	1670 tons/h	1601 tons/h	1736 tons/h	1658 tons/h	1587 tons/h	1521 tons/h	
	75 sec	1.25 min	1640 tons/h	1574 tons/h	1512 tons/h	1455 tons/h	1558 tons/h	1495 tons/h	1437 tons/h	1383 tons/h	
65%	30 sec	0.50 min	2200 tons/h	2073 tons/h	1960 tons/h	1859 tons/h	2090 tons/h	1969 tons/h	1862 tons/h	1766 tons/h	
	45 sec	0.75 min	1916 tons/h	1819 tons/h	1732 tons/h	1652 tons/h	1820 tons/h	1728 tons/h	1645 tons/h	1569 tons/h	
	60 sec	1.00 min	1697 tons/h	1621 tons/h	1551 tons/h	1487 tons/h	1612 tons/h	1540 tons/h	1473 tons/h	1412 tons/h	
	75 sec	1.25 min	1523 tons/h	1461 tons/h	1404 tons/h	1351 tons/h	1447 tons/h	1388 tons/h	1334 tons/h	1284 tons/h	

		Fill Factor		90%				85%			
		Load per Bucket		21.4 tons				20.2 tons			
		Load per Truck		85.6 tons				80.9 tons			
Overall Mine Efficiency	Cycle Time		23 sec	25 sec	27 sec	29 sec	23 sec	25 sec	27 sec	29 sec	
	Truck Spotting		0.38 min	0.42 min	0.45 min	0.48 min	0.38 min	0.42 min	0.45 min	0.48 min	
83% = maximum 50 min/hour	30 sec	0.50 min	2528 tons/h	2382 tons/h	2253 tons/h	2136 tons/h	2388 tons/h	2250 tons/h	2127 tons/h	2017 tons/h	
	45 sec	0.75 min	2202 tons/h	2091 tons/h	1990 tons/h	1899 tons/h	2080 tons/h	1975 tons/h	1879 tons/h	1793 tons/h	
	60 sec	1.00 min	1951 tons/h	1863 tons/h	1782 tons/h	1709 tons/h	1842 tons/h	1759 tons/h	1683 tons/h	1614 tons/h	
	75 sec	1.25 min	1751 tons/h	1679 tons/h	1614 tons/h	1553 tons/h	1653 tons/h	1586 tons/h	1524 tons/h	1467 tons/h	
80%	30 sec	0.50 min	2437 tons/h	2296 tons/h	2171 tons/h	2059 tons/h	2302 tons/h	2169 tons/h	2051 tons/h	1944 tons/h	
	45 sec	0.75 min	2123 tons/h	2015 tons/h	1918 tons/h	1830 tons/h	2005 tons/h	1903 tons/h	1812 tons/h	1728 tons/h	
	60 sec	1.00 min	1880 tons/h	1795 tons/h	1718 tons/h	1647 tons/h	1776 tons/h	1696 tons/h	1622 tons/h	1555 tons/h	
	75 sec	1.25 min	1687 tons/h	1619 tons/h	1556 tons/h	1497 tons/h	1594 tons/h	1529 tons/h	1469 tons/h	1414 tons/h	
75%	30 sec	0.50 min	2285 tons/h	2153 tons/h	2035 tons/h	1930 tons/h	2158 tons/h	2033 tons/h	1922 tons/h	1823 tons/h	
	45 sec	0.75 min	1990 tons/h	1889 tons/h	1798 tons/h	1716 tons/h	1879 tons/h	1794 tons/h	1698 tons/h	1620 tons/h	
	60 sec	1.00 min	1763 tons/h	1683 tons/h	1611 tons/h	1544 tons/h	1665 tons/h	1590 tons/h	1521 tons/h	1458 tons/h	
	75 sec	1.25 min	1582 tons/h	1518 tons/h	1458 tons/h	1403 tons/h	1494 tons/h	1433 tons/h	1377 tons/h	1325 tons/h	
70%	30 sec	0.50 min	2132 tons/h	2009 tons/h	1900 tons/h	1802 tons/h	2014 tons/h	1898 tons/h	1794 tons/h	1701 tons/h	
	45 sec	0.75 min	1857 tons/h	1763 tons/h	1678 tons/h	1601 tons/h	1754 tons/h	1665 tons/h	1585 tons/h	1512 tons/h	
	60 sec	1.00 min	1645 tons/h	1571 tons/h	1503 tons/h	1441 tons/h	1554 tons/h	1484 tons/h	1420 tons/h	1361 tons/h	
	75 sec	1.25 min	1476 tons/h	1416 tons/h	1361 tons/h	1310 tons/h	1394 tons/h	1338 tons/h	1285 tons/h	1237 tons/h	
65%	30 sec	0.50 min	1980 tons/h	1866 tons/h	1764 tons/h	1673 tons/h	1870 tons/h	1762 tons/h	1666 tons/h	1580 tons/h	
	45 sec	0.75 min	1725 tons/h	1637 tons/h	1558 tons/h	1487 tons/h	1629 tons/h	1546 tons/h	1472 tons/h	1404 tons/h	
	60 sec	1.00 min	1528 tons/h	1459 tons/h	1396 tons/h	1338 tons/h	1443 tons/h	1378 tons/h	1318 tons/h	1264 tons/h	
	75 sec	1.25 min	1371 tons/h	1315 tons/h	1264 tons/h	1216 tons/h	1295 tons/h	1242 tons/h	1194 tons/h	1149 tons/h	

MODEL: 6030 ● **Bucket Size: 17.0 m³** ● **Number of Cycles: 5**
 ● **Material Density: 1.80 t/m³** ● **Average Loading Conditions**

		Fill Factor		100%				95%			
		Load per Bucket		30.6 t				29.1 t			
		Load per Truck		153 t				145 t			
Overall Mine Efficiency	Truck Spotting	Cycle Time		24 sec	26 sec	28 sec	30 sec	24 sec	26 sec	28 sec	30 sec
		30 sec	0.50 min	0.40 min	0.43 min	0.47 min	0.50 min	0.40 min	0.43 min	0.47 min	0.50 min
83% = maximum 50 min/hour	30 sec	0.50 min	3560 t/h	3347 t/h	3157 t/h	2988 t/h	3382 t/h	3179 t/h	2999 t/h	2839 t/h	
	45 sec	0.75 min	3188 t/h	3016 t/h	2861 t/h	2721 t/h	3029 t/h	2865 t/h	2718 t/h	2585 t/h	
	60 sec	1.00 min	2886 t/h	2744 t/h	2615 t/h	2498 t/h	2742 t/h	2607 t/h	2485 t/h	2373 t/h	
	75 sec	1.25 min	2636 t/h	2517 t/h	2409 t/h	2309 t/h	2505 t/h	2392 t/h	2288 t/h	2193 t/h	
80%	30 sec	0.50 min	3432 t/h	3226 t/h	3043 t/h	2880 t/h	3260 t/h	3064 t/h	2891 t/h	2736 t/h	
	45 sec	0.75 min	3073 t/h	2907 t/h	2757 t/h	2623 t/h	2919 t/h	2761 t/h	2620 t/h	2492 t/h	
	60 sec	1.00 min	2782 t/h	2645 t/h	2521 t/h	2408 t/h	2643 t/h	2513 t/h	2395 t/h	2287 t/h	
	75 sec	1.25 min	2541 t/h	2426 t/h	2322 t/h	2225 t/h	2414 t/h	2305 t/h	2206 t/h	2114 t/h	
75%	30 sec	0.50 min	3217 t/h	3024 t/h	2853 t/h	2700 t/h	3056 t/h	2873 t/h	2710 t/h	2565 t/h	
	45 sec	0.75 min	2881 t/h	2725 t/h	2585 t/h	2459 t/h	2737 t/h	2589 t/h	2456 t/h	2336 t/h	
	60 sec	1.00 min	2608 t/h	2480 t/h	2363 t/h	2257 t/h	2478 t/h	2356 t/h	2245 t/h	2145 t/h	
	75 sec	1.25 min	2382 t/h	2275 t/h	2177 t/h	2086 t/h	2263 t/h	2161 t/h	2068 t/h	1982 t/h	
70%	30 sec	0.50 min	3003 t/h	2823 t/h	2663 t/h	2520 t/h	2853 t/h	2681 t/h	2530 t/h	2394 t/h	
	45 sec	0.75 min	2689 t/h	2543 t/h	2413 t/h	2295 t/h	2554 t/h	2416 t/h	2292 t/h	2180 t/h	
	60 sec	1.00 min	2434 t/h	2314 t/h	2206 t/h	2107 t/h	2312 t/h	2199 t/h	2095 t/h	2002 t/h	
	75 sec	1.25 min	2224 t/h	2123 t/h	2031 t/h	1947 t/h	2112 t/h	2011 t/h	1930 t/h	1850 t/h	
65%	30 sec	0.50 min	2788 t/h	2621 t/h	2473 t/h	2340 t/h	2649 t/h	2490 t/h	2349 t/h	2223 t/h	
	45 sec	0.75 min	2497 t/h	2362 t/h	2240 t/h	2131 t/h	2372 t/h	2244 t/h	2128 t/h	2025 t/h	
	60 sec	1.00 min	2260 t/h	2149 t/h	2048 t/h	1956 t/h	2147 t/h	2042 t/h	1946 t/h	1859 t/h	
	75 sec	1.25 min	2065 t/h	1971 t/h	1886 t/h	1808 t/h	1961 t/h	1873 t/h	1792 t/h	1718 t/h	

		Fill Factor		90%				85%			
		Load per Bucket		27.5 t				26.0 t			
		Load per Truck		138 t				130 t			
Overall Mine Efficiency	Truck Spotting	Cycle Time		24 sec	26 sec	28 sec	30 sec	24 sec	26 sec	28 sec	30 sec
		30 sec	0.50 min	0.40 min	0.43 min	0.47 min	0.50 min	0.40 min	0.43 min	0.47 min	0.50 min
83% = maximum 50 min/hour	30 sec	0.50 min	3204 t/h	3012 t/h	2841 t/h	2689 t/h	3026 t/h	2845 t/h	2684 t/h	2540 t/h	
	45 sec	0.75 min	2869 t/h	2714 t/h	2575 t/h	2449 t/h	2710 t/h	2563 t/h	2432 t/h	2313 t/h	
	60 sec	1.00 min	2598 t/h	2470 t/h	2354 t/h	2248 t/h	2453 t/h	2332 t/h	2223 t/h	2123 t/h	
	75 sec	1.25 min	2373 t/h	2266 t/h	2168 t/h	2078 t/h	2241 t/h	2140 t/h	2047 t/h	1963 t/h	
80%	30 sec	0.50 min	3089 t/h	2903 t/h	2739 t/h	2592 t/h	2917 t/h	2742 t/h	2587 t/h	2448 t/h	
	45 sec	0.75 min	2766 t/h	2616 t/h	2482 t/h	2361 t/h	2612 t/h	2471 t/h	2344 t/h	2229 t/h	
	60 sec	1.00 min	2504 t/h	2380 t/h	2269 t/h	2167 t/h	2365 t/h	2248 t/h	2143 t/h	2047 t/h	
	75 sec	1.25 min	2287 t/h	2184 t/h	2089 t/h	2003 t/h	2160 t/h	2062 t/h	1973 t/h	1892 t/h	
75%	30 sec	0.50 min	2896 t/h	2722 t/h	2568 t/h	2430 t/h	2735 t/h	2571 t/h	2425 t/h	2295 t/h	
	45 sec	0.75 min	2593 t/h	2452 t/h	2327 t/h	2213 t/h	2449 t/h	2316 t/h	2197 t/h	2090 t/h	
	60 sec	1.00 min	2347 t/h	2232 t/h	2127 t/h	2032 t/h	2217 t/h	2108 t/h	2009 t/h	1919 t/h	
	75 sec	1.25 min	2144 t/h	2047 t/h	1959 t/h	1878 t/h	2025 t/h	1934 t/h	1850 t/h	1773 t/h	
70%	30 sec	0.50 min	2703 t/h	2540 t/h	2396 t/h	2268 t/h	2552 t/h	2399 t/h	2263 t/h	2142 t/h	
	45 sec	0.75 min	2420 t/h	2289 t/h	2171 t/h	2066 t/h	2285 t/h	2162 t/h	2051 t/h	1951 t/h	
	60 sec	1.00 min	2191 t/h	2083 t/h	1985 t/h	1896 t/h	2069 t/h	1967 t/h	1875 t/h	1791 t/h	
	75 sec	1.25 min	2001 t/h	1911 t/h	1828 t/h	1753 t/h	1890 t/h	1805 t/h	1727 t/h	1655 t/h	
65%	30 sec	0.50 min	2509 t/h	2359 t/h	2225 t/h	2106 t/h	2370 t/h	2228 t/h	2102 t/h	1989 t/h	
	45 sec	0.75 min	2247 t/h	2125 t/h	2016 t/h	1918 t/h	2122 t/h	2007 t/h	1904 t/h	1811 t/h	
	60 sec	1.00 min	2034 t/h	1934 t/h	1843 t/h	1761 t/h	1921 t/h	1827 t/h	1741 t/h	1663 t/h	
	75 sec	1.25 min	1858 t/h	1774 t/h	1698 t/h	1627 t/h	1755 t/h	1676 t/h	1603 t/h	1537 t/h	

MODEL: 6030 ● Bucket Size: 22.2 yd³ ● Number of Cycles: 5
● Material Density: 3030 lb/yd³ ● Average Loading Conditions

			100%				95%			
Fill Factor			33.6 tons				32.0 tons			
Load per Bucket			168.2 tons				159.8 tons			
Load per Truck										
Overall Mine Efficiency	Cycle Time		24 sec	26 sec	28 sec	30 sec	24 sec	26 sec	28 sec	30 sec
	Truck Spotting		0.40 min	0.43 min	0.47 min	0.50 min	0.40 min	0.43 min	0.47 min	0.50 min
83% = maximum 50 min/hour	30 sec	0.50 min	3913 tons/h	3678 tons/h	3470 tons/h	3284 tons/h	3718 tons/h	3495 tons/h	3297 tons/h	3120 tons/h
	45 sec	0.75 min	3504 tons/h	3314 tons/h	3144 tons/h	2991 tons/h	3329 tons/h	3149 tons/h	2987 tons/h	2841 tons/h
	60 sec	1.00 min	3172 tons/h	3016 tons/h	2875 tons/h	2746 tons/h	3014 tons/h	2865 tons/h	2731 tons/h	2608 tons/h
	75 sec	1.25 min	2898 tons/h	2767 tons/h	2647 tons/h	2538 tons/h	2753 tons/h	2629 tons/h	2515 tons/h	2411 tons/h
80%	30 sec	0.50 min	3772 tons/h	3545 tons/h	3345 tons/h	3165 tons/h	3583 tons/h	3368 tons/h	3177 tons/h	3007 tons/h
	45 sec	0.75 min	3377 tons/h	3195 tons/h	3031 tons/h	2883 tons/h	3209 tons/h	3035 tons/h	2879 tons/h	2739 tons/h
	60 sec	1.00 min	3058 tons/h	2907 tons/h	2771 tons/h	2647 tons/h	2905 tons/h	2762 tons/h	2632 tons/h	2514 tons/h
	75 sec	1.25 min	2793 tons/h	2667 tons/h	2552 tons/h	2446 tons/h	2653 tons/h	2534 tons/h	2424 tons/h	2324 tons/h
75%	30 sec	0.50 min	3536 tons/h	3324 tons/h	3136 tons/h	2968 tons/h	3359 tons/h	3158 tons/h	2979 tons/h	2819 tons/h
	45 sec	0.75 min	3166 tons/h	2995 tons/h	2841 tons/h	2703 tons/h	3008 tons/h	2845 tons/h	2699 tons/h	2568 tons/h
	60 sec	1.00 min	2866 tons/h	2725 tons/h	2598 tons/h	2481 tons/h	2723 tons/h	2589 tons/h	2468 tons/h	2357 tons/h
	75 sec	1.25 min	2618 tons/h	2500 tons/h	2392 tons/h	2293 tons/h	2488 tons/h	2375 tons/h	2273 tons/h	2179 tons/h
70%	30 sec	0.50 min	3300 tons/h	3102 tons/h	2927 tons/h	2770 tons/h	3135 tons/h	2947 tons/h	2780 tons/h	2631 tons/h
	45 sec	0.75 min	2955 tons/h	2795 tons/h	2652 tons/h	2522 tons/h	2807 tons/h	2656 tons/h	2519 tons/h	2396 tons/h
	60 sec	1.00 min	2675 tons/h	2544 tons/h	2424 tons/h	2316 tons/h	2542 tons/h	2416 tons/h	2303 tons/h	2200 tons/h
	75 sec	1.25 min	2444 tons/h	2334 tons/h	2233 tons/h	2140 tons/h	2322 tons/h	2217 tons/h	2121 tons/h	2033 tons/h
65%	30 sec	0.50 min	3065 tons/h	2881 tons/h	2718 tons/h	2572 tons/h	2911 tons/h	2737 tons/h	2582 tons/h	2443 tons/h
	45 sec	0.75 min	2744 tons/h	2596 tons/h	2462 tons/h	2342 tons/h	2607 tons/h	2466 tons/h	2339 tons/h	2225 tons/h
	60 sec	1.00 min	2484 tons/h	2362 tons/h	2251 tons/h	2150 tons/h	2360 tons/h	2244 tons/h	2139 tons/h	2043 tons/h
	75 sec	1.25 min	2269 tons/h	2167 tons/h	2073 tons/h	1987 tons/h	2156 tons/h	2059 tons/h	1970 tons/h	1888 tons/h

			90%				85%			
Fill Factor			30.3 tons				28.6 tons			
Load per Bucket			151.3 tons				142.9 tons			
Load per Truck										
Overall Mine Efficiency	Cycle Time		24 sec	26 sec	28 sec	30 sec	24 sec	26 sec	28 sec	30 sec
	Truck Spotting		0.40 min	0.43 min	0.47 min	0.50 min	0.40 min	0.43 min	0.47 min	0.50 min
83% = maximum 50 min/hour	30 sec	0.50 min	3522 tons/h	3311 tons/h	3123 tons/h	2956 tons/h	3326 tons/h	3127 tons/h	2950 tons/h	2792 tons/h
	45 sec	0.75 min	3154 tons/h	2983 tons/h	2830 tons/h	2692 tons/h	2978 tons/h	2817 tons/h	2673 tons/h	2542 tons/h
	60 sec	1.00 min	2855 tons/h	2714 tons/h	2587 tons/h	2471 tons/h	2696 tons/h	2564 tons/h	2443 tons/h	2334 tons/h
	75 sec	1.25 min	2608 tons/h	2490 tons/h	2383 tons/h	2284 tons/h	2463 tons/h	2352 tons/h	2250 tons/h	2157 tons/h
80%	30 sec	0.50 min	3395 tons/h	3191 tons/h	3010 tons/h	2849 tons/h	3206 tons/h	3014 tons/h	2843 tons/h	2691 tons/h
	45 sec	0.75 min	3040 tons/h	2875 tons/h	2728 tons/h	2595 tons/h	2871 tons/h	2715 tons/h	2576 tons/h	2450 tons/h
	60 sec	1.00 min	2752 tons/h	2616 tons/h	2494 tons/h	2382 tons/h	2599 tons/h	2471 tons/h	2355 tons/h	2250 tons/h
	75 sec	1.25 min	2514 tons/h	2400 tons/h	2297 tons/h	2201 tons/h	2374 tons/h	2267 tons/h	2169 tons/h	2079 tons/h
75%	30 sec	0.50 min	3183 tons/h	2992 tons/h	2822 tons/h	2671 tons/h	3006 tons/h	2825 tons/h	2665 tons/h	2522 tons/h
	45 sec	0.75 min	2850 tons/h	2696 tons/h	2557 tons/h	2432 tons/h	2691 tons/h	2546 tons/h	2415 tons/h	2297 tons/h
	60 sec	1.00 min	2580 tons/h	2453 tons/h	2338 tons/h	2233 tons/h	2436 tons/h	2317 tons/h	2208 tons/h	2109 tons/h
	75 sec	1.25 min	2357 tons/h	2250 tons/h	2153 tons/h	2064 tons/h	2226 tons/h	2125 tons/h	2033 tons/h	1949 tons/h
70%	30 sec	0.50 min	2970 tons/h	2792 tons/h	2634 tons/h	2493 tons/h	2805 tons/h	2637 tons/h	2488 tons/h	2354 tons/h
	45 sec	0.75 min	2660 tons/h	2516 tons/h	2387 tons/h	2270 tons/h	2512 tons/h	2376 tons/h	2254 tons/h	2144 tons/h
	60 sec	1.00 min	2408 tons/h	2289 tons/h	2182 tons/h	2084 tons/h	2274 tons/h	2162 tons/h	2061 tons/h	1968 tons/h
	75 sec	1.25 min	2200 tons/h	2100 tons/h	2009 tons/h	1926 tons/h	2077 tons/h	1984 tons/h	1898 tons/h	1819 tons/h
65%	30 sec	0.50 min	2758 tons/h	2593 tons/h	2446 tons/h	2315 tons/h	2605 tons/h	2449 tons/h	2310 tons/h	2186 tons/h
	45 sec	0.75 min	2470 tons/h	2336 tons/h	2216 tons/h	2108 tons/h	2332 tons/h	2206 tons/h	2093 tons/h	1991 tons/h
	60 sec	1.00 min	2236 tons/h	2126 tons/h	2026 tons/h	1935 tons/h	2112 tons/h	2008 tons/h	1914 tons/h	1828 tons/h
	75 sec	1.25 min	2042 tons/h	1950 tons/h	1866 tons/h	1789 tons/h	1929 tons/h	1842 tons/h	1762 tons/h	1689 tons/h

MODEL: 6030 FS ● **Bucket Size: 16.5 m³** ● **Number of Cycles: 5**
 ● **Material Density: 1.80 t/m³** ● **Average Loading Conditions**

		Fill Factor		100%				95%			
		Load per Bucket		29.7 t				28.2 t			
		Load per Truck		149 t				141 t			
Overall Mine Efficiency	Truck Spotting	Cycle Time		24 sec	26 sec	28 sec	30 sec	24 sec	26 sec	28 sec	30 sec
		30 sec	0.50 min	0.40 min	0.43 min	0.47 min	0.50 min	0.40 min	0.43 min	0.47 min	0.50 min
83% = maximum 50 min/hour	30 sec	0.50 min	3456 t/h	3248 t/h	3064 t/h	2900 t/h	3283 t/h	3086 t/h	2911 t/h	2755 t/h	
	45 sec	0.75 min	3094 t/h	2927 t/h	2777 t/h	2641 t/h	2940 t/h	2781 t/h	2638 t/h	2509 t/h	
	60 sec	1.00 min	2801 t/h	2663 t/h	2538 t/h	2425 t/h	2661 t/h	2530 t/h	2412 t/h	2303 t/h	
	75 sec	1.25 min	2559 t/h	2443 t/h	2338 t/h	2241 t/h	2431 t/h	2321 t/h	2221 t/h	2129 t/h	
80%	30 sec	0.50 min	3331 t/h	3131 t/h	2954 t/h	2795 t/h	3164 t/h	2974 t/h	2806 t/h	2656 t/h	
	45 sec	0.75 min	2982 t/h	2821 t/h	2676 t/h	2546 t/h	2833 t/h	2680 t/h	2543 t/h	2418 t/h	
	60 sec	1.00 min	2700 t/h	2567 t/h	2447 t/h	2337 t/h	2565 t/h	2439 t/h	2324 t/h	2220 t/h	
	75 sec	1.25 min	2466 t/h	2355 t/h	2253 t/h	2160 t/h	2343 t/h	2237 t/h	2141 t/h	2052 t/h	
75%	30 sec	0.50 min	3123 t/h	2935 t/h	2769 t/h	2621 t/h	2967 t/h	2788 t/h	2631 t/h	2490 t/h	
	45 sec	0.75 min	2796 t/h	2645 t/h	2509 t/h	2387 t/h	2656 t/h	2513 t/h	2384 t/h	2267 t/h	
	60 sec	1.00 min	2531 t/h	2407 t/h	2294 t/h	2191 t/h	2405 t/h	2286 t/h	2179 t/h	2081 t/h	
	75 sec	1.25 min	2312 t/h	2208 t/h	2112 t/h	2025 t/h	2197 t/h	2097 t/h	2007 t/h	1924 t/h	
70%	30 sec	0.50 min	2914 t/h	2740 t/h	2584 t/h	2446 t/h	2769 t/h	2603 t/h	2455 t/h	2324 t/h	
	45 sec	0.75 min	2610 t/h	2468 t/h	2342 t/h	2228 t/h	2479 t/h	2345 t/h	2225 t/h	2116 t/h	
	60 sec	1.00 min	2362 t/h	2246 t/h	2141 t/h	2045 t/h	2244 t/h	2134 t/h	2034 t/h	1943 t/h	
	75 sec	1.25 min	2158 t/h	2061 t/h	1972 t/h	1890 t/h	2050 t/h	1958 t/h	1873 t/h	1796 t/h	
65%	30 sec	0.50 min	2706 t/h	2544 t/h	2400 t/h	2271 t/h	2571 t/h	2417 t/h	2280 t/h	2158 t/h	
	45 sec	0.75 min	2423 t/h	2292 t/h	2175 t/h	2068 t/h	2302 t/h	2178 t/h	2066 t/h	1965 t/h	
	60 sec	1.00 min	2194 t/h	2086 t/h	1988 t/h	1899 t/h	2084 t/h	1981 t/h	1889 t/h	1804 t/h	
	75 sec	1.25 min	2004 t/h	1913 t/h	1831 t/h	1755 t/h	1904 t/h	1818 t/h	1739 t/h	1667 t/h	

		Fill Factor		90%				85%			
		Load per Bucket		26.7 t				25.2 t			
		Load per Truck		134 t				126 t			
Overall Mine Efficiency	Truck Spotting	Cycle Time		24 sec	26 sec	28 sec	30 sec	24 sec	26 sec	28 sec	30 sec
		30 sec	0.50 min	0.40 min	0.43 min	0.47 min	0.50 min	0.40 min	0.43 min	0.47 min	0.50 min
83% = maximum 50 min/hour	30 sec	0.50 min	3110 t/h	2923 t/h	2758 t/h	2610 t/h	2937 t/h	2761 t/h	2605 t/h	2465 t/h	
	45 sec	0.75 min	2785 t/h	2634 t/h	2499 t/h	2377 t/h	2630 t/h	2488 t/h	2360 t/h	2245 t/h	
	60 sec	1.00 min	2521 t/h	2397 t/h	2285 t/h	2182 t/h	2381 t/h	2264 t/h	2158 t/h	2061 t/h	
	75 sec	1.25 min	2303 t/h	2199 t/h	2104 t/h	2017 t/h	2175 t/h	2077 t/h	1987 t/h	1905 t/h	
80%	30 sec	0.50 min	2998 t/h	2818 t/h	2658 t/h	2516 t/h	2831 t/h	2661 t/h	2511 t/h	2376 t/h	
	45 sec	0.75 min	2684 t/h	2539 t/h	2409 t/h	2291 t/h	2535 t/h	2398 t/h	2275 t/h	2164 t/h	
	60 sec	1.00 min	2430 t/h	2310 t/h	2202 t/h	2103 t/h	2295 t/h	2182 t/h	2080 t/h	1986 t/h	
	75 sec	1.25 min	2220 t/h	2120 t/h	2028 t/h	1944 t/h	2096 t/h	2002 t/h	1915 t/h	1836 t/h	
75%	30 sec	0.50 min	2810 t/h	2642 t/h	2492 t/h	2359 t/h	2654 t/h	2495 t/h	2354 t/h	2228 t/h	
	45 sec	0.75 min	2516 t/h	2380 t/h	2258 t/h	2148 t/h	2377 t/h	2248 t/h	2133 t/h	2029 t/h	
	60 sec	1.00 min	2278 t/h	2166 t/h	2064 t/h	1972 t/h	2152 t/h	2046 t/h	1950 t/h	1862 t/h	
	75 sec	1.25 min	2081 t/h	1987 t/h	1901 t/h	1822 t/h	1965 t/h	1877 t/h	1796 t/h	1721 t/h	
70%	30 sec	0.50 min	2623 t/h	2466 t/h	2326 t/h	2201 t/h	2477 t/h	2329 t/h	2197 t/h	2079 t/h	
	45 sec	0.75 min	2349 t/h	2222 t/h	2108 t/h	2005 t/h	2218 t/h	2098 t/h	1991 t/h	1893 t/h	
	60 sec	1.00 min	2126 t/h	2022 t/h	1927 t/h	1840 t/h	2008 t/h	1909 t/h	1820 t/h	1738 t/h	
	75 sec	1.25 min	1942 t/h	1855 t/h	1774 t/h	1701 t/h	1834 t/h	1752 t/h	1676 t/h	1606 t/h	
65%	30 sec	0.50 min	2436 t/h	2289 t/h	2160 t/h	2044 t/h	2300 t/h	2162 t/h	2040 t/h	1930 t/h	
	45 sec	0.75 min	2181 t/h	2063 t/h	1957 t/h	1862 t/h	2060 t/h	1948 t/h	1848 t/h	1758 t/h	
	60 sec	1.00 min	1974 t/h	1877 t/h	1789 t/h	1709 t/h	1865 t/h	1773 t/h	1690 t/h	1614 t/h	
	75 sec	1.25 min	1804 t/h	1722 t/h	1648 t/h	1580 t/h	1703 t/h	1626 t/h	1556 t/h	1492 t/h	

MODEL: 6030 FS ● Bucket Size: 21.6 yd³ ● Number of Cycles: 5
● Material Density: 3030 lb/yd³ ● Average Loading Conditions

			100%				95%			
Fill Factor			32.7 tons				31.1 tons			
Load per Bucket			163.6 tons				155.4 tons			
Load per Truck										
Overall Mine Efficiency	Cycle Time		24 sec	26 sec	28 sec	30 sec	24 sec	26 sec	28 sec	30 sec
	Truck Spotting		0.40 min	0.43 min	0.47 min	0.50 min	0.40 min	0.43 min	0.47 min	0.50 min
83% = maximum 50 min/hour	30 sec	0.50 min	3808 tons/h	3579 tons/h	3376 tons/h	3195 tons/h	3617 tons/h	3400 tons/h	3208 tons/h	3036 tons/h
	45 sec	0.75 min	3409 tons/h	3225 tons/h	3059 tons/h	2910 tons/h	3239 tons/h	3064 tons/h	2906 tons/h	2765 tons/h
	60 sec	1.00 min	3086 tons/h	2935 tons/h	2797 tons/h	2672 tons/h	2932 tons/h	2788 tons/h	2657 tons/h	2538 tons/h
	75 sec	1.25 min	2819 tons/h	2692 tons/h	2576 tons/h	2469 tons/h	2678 tons/h	2558 tons/h	2447 tons/h	2346 tons/h
80%	30 sec	0.50 min	3670 tons/h	3450 tons/h	3254 tons/h	3080 tons/h	3486 tons/h	3270 tons/h	3092 tons/h	2926 tons/h
	45 sec	0.75 min	3286 tons/h	3108 tons/h	2949 tons/h	2805 tons/h	3122 tons/h	2953 tons/h	2801 tons/h	2665 tons/h
	60 sec	1.00 min	2975 tons/h	2828 tons/h	2696 tons/h	2575 tons/h	2826 tons/h	2687 tons/h	2561 tons/h	2446 tons/h
	75 sec	1.25 min	2718 tons/h	2595 tons/h	2483 tons/h	2380 tons/h	2582 tons/h	2465 tons/h	2359 tons/h	2261 tons/h
75%	30 sec	0.50 min	3441 tons/h	3234 tons/h	3051 tons/h	2887 tons/h	3269 tons/h	3072 tons/h	2898 tons/h	2743 tons/h
	45 sec	0.75 min	3081 tons/h	2914 tons/h	2765 tons/h	2630 tons/h	2927 tons/h	2768 tons/h	2626 tons/h	2498 tons/h
	60 sec	1.00 min	2789 tons/h	2652 tons/h	2527 tons/h	2414 tons/h	2650 tons/h	2519 tons/h	2401 tons/h	2293 tons/h
	75 sec	1.25 min	2548 tons/h	2433 tons/h	2328 tons/h	2231 tons/h	2420 tons/h	2311 tons/h	2211 tons/h	2120 tons/h
70%	30 sec	0.50 min	3211 tons/h	3018 tons/h	2848 tons/h	2695 tons/h	3051 tons/h	2868 tons/h	2705 tons/h	2560 tons/h
	45 sec	0.75 min	2875 tons/h	2720 tons/h	2580 tons/h	2454 tons/h	2732 tons/h	2584 tons/h	2451 tons/h	2332 tons/h
	60 sec	1.00 min	2603 tons/h	2475 tons/h	2359 tons/h	2253 tons/h	2473 tons/h	2351 tons/h	2241 tons/h	2140 tons/h
	75 sec	1.25 min	2378 tons/h	2270 tons/h	2172 tons/h	2082 tons/h	2259 tons/h	2157 tons/h	2064 tons/h	1978 tons/h
65%	30 sec	0.50 min	2982 tons/h	2803 tons/h	2644 tons/h	2502 tons/h	2833 tons/h	2663 tons/h	2512 tons/h	2377 tons/h
	45 sec	0.75 min	2670 tons/h	2526 tons/h	2396 tons/h	2279 tons/h	2536 tons/h	2399 tons/h	2276 tons/h	2165 tons/h
	60 sec	1.00 min	2417 tons/h	2298 tons/h	2190 tons/h	2092 tons/h	2296 tons/h	2183 tons/h	2081 tons/h	1988 tons/h
	75 sec	1.25 min	2208 tons/h	2108 tons/h	2017 tons/h	1934 tons/h	2098 tons/h	2003 tons/h	1916 tons/h	1837 tons/h

			90%				85%			
Fill Factor			29.5 tons				27.8 tons			
Load per Bucket			147.3 tons				139.1 tons			
Load per Truck										
Overall Mine Efficiency	Cycle Time		24 sec	26 sec	28 sec	30 sec	24 sec	26 sec	28 sec	30 sec
	Truck Spotting		0.40 min	0.43 min	0.47 min	0.50 min	0.40 min	0.43 min	0.47 min	0.50 min
83% = maximum 50 min/hour	30 sec	0.50 min	3427 tons/h	3221 tons/h	3039 tons/h	2876 tons/h	3236 tons/h	3042 tons/h	2870 tons/h	2716 tons/h
	45 sec	0.75 min	3068 tons/h	2902 tons/h	2753 tons/h	2619 tons/h	2898 tons/h	2741 tons/h	2601 tons/h	2474 tons/h
	60 sec	1.00 min	2778 tons/h	2641 tons/h	2517 tons/h	2404 tons/h	2623 tons/h	2494 tons/h	2291 tons/h	2189 tons/h
	75 sec	1.25 min	2538 tons/h	2423 tons/h	2318 tons/h	2222 tons/h	2397 tons/h	2288 tons/h	2189 tons/h	2099 tons/h
80%	30 sec	0.50 min	3303 tons/h	3105 tons/h	2929 tons/h	2772 tons/h	3119 tons/h	2932 tons/h	2766 tons/h	2618 tons/h
	45 sec	0.75 min	2957 tons/h	2798 tons/h	2654 tons/h	2524 tons/h	2793 tons/h	2642 tons/h	2507 tons/h	2384 tons/h
	60 sec	1.00 min	2677 tons/h	2546 tons/h	2426 tons/h	2318 tons/h	2529 tons/h	2404 tons/h	2291 tons/h	2189 tons/h
	75 sec	1.25 min	2446 tons/h	2335 tons/h	2234 tons/h	2142 tons/h	2310 tons/h	2206 tons/h	2110 tons/h	2023 tons/h
75%	30 sec	0.50 min	3097 tons/h	2911 tons/h	2746 tons/h	2599 tons/h	2925 tons/h	2749 tons/h	2593 tons/h	2454 tons/h
	45 sec	0.75 min	2773 tons/h	2623 tons/h	2488 tons/h	2367 tons/h	2619 tons/h	2477 tons/h	2350 tons/h	2235 tons/h
	60 sec	1.00 min	2510 tons/h	2387 tons/h	2275 tons/h	2173 tons/h	2371 tons/h	2254 tons/h	2148 tons/h	2052 tons/h
	75 sec	1.25 min	2293 tons/h	2189 tons/h	2095 tons/h	2008 tons/h	2166 tons/h	2068 tons/h	1978 tons/h	1897 tons/h
70%	30 sec	0.50 min	2890 tons/h	2717 tons/h	2563 tons/h	2425 tons/h	2730 tons/h	2566 tons/h	2420 tons/h	2291 tons/h
	45 sec	0.75 min	2588 tons/h	2448 tons/h	2322 tons/h	2209 tons/h	2444 tons/h	2312 tons/h	2193 tons/h	2086 tons/h
	60 sec	1.00 min	2343 tons/h	2227 tons/h	2123 tons/h	2028 tons/h	2213 tons/h	2104 tons/h	2005 tons/h	1915 tons/h
	75 sec	1.25 min	2140 tons/h	2043 tons/h	1955 tons/h	1874 tons/h	2021 tons/h	1930 tons/h	1847 tons/h	1770 tons/h
65%	30 sec	0.50 min	2684 tons/h	2523 tons/h	2380 tons/h	2252 tons/h	2535 tons/h	2382 tons/h	2248 tons/h	2127 tons/h
	45 sec	0.75 min	2403 tons/h	2273 tons/h	2156 tons/h	2051 tons/h	2269 tons/h	2147 tons/h	2037 tons/h	1937 tons/h
	60 sec	1.00 min	2175 tons/h	2068 tons/h	1971 tons/h	1883 tons/h	2055 tons/h	1953 tons/h	1862 tons/h	1778 tons/h
	75 sec	1.25 min	1987 tons/h	1897 tons/h	1816 tons/h	1740 tons/h	1877 tons/h	1792 tons/h	1715 tons/h	1644 tons/h

MODEL: 6040 and 6040 FS ● **Bucket Size: 22.0 m³** ● **Number of Cycles: 4**
 ● **Material Density: 1.80 t/m³** ● **Average Loading Conditions**

		Fill Factor		100%				95%			
		Load per Bucket		39.6 t				37.6 t			
		Load per Truck		158 t				150 t			
Overall Mine Efficiency	Truck Spotting	Cycle Time		24 sec	26 sec	28 sec	30 sec	24 sec	26 sec	28 sec	30 sec
		30 sec	0.50 min	0.40 min	0.43 min	0.47 min	0.50 min	0.40 min	0.43 min	0.47 min	0.50 min
83% = maximum 50 min/hour	30 sec	0.50 min	4534 t/h	4279 t/h	4052 t/h	3848 t/h	4307 t/h	4065 t/h	3850 t/h	3656 t/h	
	45 sec	0.75 min	3964 t/h	3768 t/h	3591 t/h	3430 t/h	3766 t/h	3580 t/h	3411 t/h	3258 t/h	
	60 sec	1.00 min	3522 t/h	3366 t/h	3224 t/h	3093 t/h	3345 t/h	3198 t/h	3063 t/h	2939 t/h	
	75 sec	1.25 min	3168 t/h	3042 t/h	2925 t/h	2817 t/h	3010 t/h	2890 t/h	2779 t/h	2676 t/h	
80%	30 sec	0.50 min	4370 t/h	4125 t/h	3906 t/h	3709 t/h	4151 t/h	3918 t/h	3710 t/h	3523 t/h	
	45 sec	0.75 min	3821 t/h	3632 t/h	3461 t/h	3306 t/h	3630 t/h	3450 t/h	3288 t/h	3140 t/h	
	60 sec	1.00 min	3394 t/h	3245 t/h	3108 t/h	2982 t/h	3225 t/h	3082 t/h	2952 t/h	2833 t/h	
	75 sec	1.25 min	3053 t/h	2932 t/h	2819 t/h	2715 t/h	2901 t/h	2785 t/h	2679 t/h	2580 t/h	
75%	30 sec	0.50 min	4097 t/h	3867 t/h	3662 t/h	3477 t/h	3892 t/h	3674 t/h	3479 t/h	3303 t/h	
	45 sec	0.75 min	3582 t/h	3405 t/h	3245 t/h	3099 t/h	3403 t/h	3235 t/h	3083 t/h	2944 t/h	
	60 sec	1.00 min	3182 t/h	3042 t/h	2913 t/h	2795 t/h	3023 t/h	2890 t/h	2768 t/h	2656 t/h	
	75 sec	1.25 min	2863 t/h	2749 t/h	2643 t/h	2546 t/h	2720 t/h	2611 t/h	2511 t/h	2418 t/h	
70%	30 sec	0.50 min	3823 t/h	3609 t/h	3418 t/h	3245 t/h	3632 t/h	3429 t/h	3247 t/h	3083 t/h	
	45 sec	0.75 min	3343 t/h	3178 t/h	3029 t/h	2893 t/h	3176 t/h	3019 t/h	2877 t/h	2748 t/h	
	60 sec	1.00 min	2970 t/h	2839 t/h	2719 t/h	2609 t/h	2822 t/h	2697 t/h	2583 t/h	2478 t/h	
	75 sec	1.25 min	2672 t/h	2565 t/h	2467 t/h	2376 t/h	2538 t/h	2437 t/h	2344 t/h	2257 t/h	
65%	30 sec	0.50 min	3550 t/h	3351 t/h	3173 t/h	3013 t/h	3373 t/h	3184 t/h	3015 t/h	2863 t/h	
	45 sec	0.75 min	3104 t/h	2951 t/h	2812 t/h	2686 t/h	2949 t/h	2804 t/h	2672 t/h	2552 t/h	
	60 sec	1.00 min	2758 t/h	2636 t/h	2525 t/h	2423 t/h	2620 t/h	2504 t/h	2399 t/h	2301 t/h	
	75 sec	1.25 min	2481 t/h	2382 t/h	2291 t/h	2206 t/h	2357 t/h	2263 t/h	2176 t/h	2096 t/h	

		Fill Factor		90%				85%			
		Load per Bucket		35.6 t				33.7 t			
		Load per Truck		143 t				135 t			
Overall Mine Efficiency	Truck Spotting	Cycle Time		24 sec	26 sec	28 sec	30 sec	24 sec	26 sec	28 sec	30 sec
		30 sec	0.50 min	0.40 min	0.43 min	0.47 min	0.50 min	0.40 min	0.43 min	0.47 min	0.50 min
83% = maximum 50 min/hour	30 sec	0.50 min	4080 t/h	3851 t/h	3647 t/h	3463 t/h	3853 t/h	3637 t/h	3444 t/h	3271 t/h	
	45 sec	0.75 min	3568 t/h	3391 t/h	3232 t/h	3087 t/h	3369 t/h	3203 t/h	3052 t/h	2915 t/h	
	60 sec	1.00 min	3169 t/h	3030 t/h	2902 t/h	2784 t/h	2993 t/h	2861 t/h	2740 t/h	2629 t/h	
	75 sec	1.25 min	2851 t/h	2738 t/h	2633 t/h	2536 t/h	2693 t/h	2586 t/h	2486 t/h	2395 t/h	
80%	30 sec	0.50 min	3933 t/h	3712 t/h	3515 t/h	3338 t/h	3714 t/h	3506 t/h	3320 t/h	3153 t/h	
	45 sec	0.75 min	3439 t/h	3269 t/h	3115 t/h	2975 t/h	3248 t/h	3087 t/h	2942 t/h	2810 t/h	
	60 sec	1.00 min	3055 t/h	2920 t/h	2797 t/h	2683 t/h	2885 t/h	2758 t/h	2641 t/h	2534 t/h	
	75 sec	1.25 min	2748 t/h	2639 t/h	2538 t/h	2444 t/h	2595 t/h	2492 t/h	2397 t/h	2308 t/h	
75%	30 sec	0.50 min	3687 t/h	3480 t/h	3295 t/h	3129 t/h	3482 t/h	3287 t/h	3112 t/h	2956 t/h	
	45 sec	0.75 min	3224 t/h	3065 t/h	2920 t/h	2789 t/h	3045 t/h	2894 t/h	2758 t/h	2634 t/h	
	60 sec	1.00 min	2864 t/h	2738 t/h	2622 t/h	2516 t/h	2705 t/h	2586 t/h	2476 t/h	2376 t/h	
	75 sec	1.25 min	2576 t/h	2474 t/h	2379 t/h	2291 t/h	2433 t/h	2336 t/h	2247 t/h	2164 t/h	
70%	30 sec	0.50 min	3441 t/h	3248 t/h	3076 t/h	2921 t/h	3250 t/h	3068 t/h	2905 t/h	2758 t/h	
	45 sec	0.75 min	3009 t/h	2860 t/h	2726 t/h	2603 t/h	2842 t/h	2701 t/h	2574 t/h	2459 t/h	
	60 sec	1.00 min	2673 t/h	2555 t/h	2447 t/h	2348 t/h	2524 t/h	2413 t/h	2311 t/h	2218 t/h	
	75 sec	1.25 min	2405 t/h	2309 t/h	2220 t/h	2138 t/h	2271 t/h	2181 t/h	2097 t/h	2020 t/h	
65%	30 sec	0.50 min	3195 t/h	3016 t/h	2856 t/h	2712 t/h	3018 t/h	2849 t/h	2697 t/h	2561 t/h	
	45 sec	0.75 min	2794 t/h	2656 t/h	2531 t/h	2417 t/h	2639 t/h	2508 t/h	2390 t/h	2283 t/h	
	60 sec	1.00 min	2482 t/h	2373 t/h	2272 t/h	2180 t/h	2344 t/h	2241 t/h	2146 t/h	2059 t/h	
	75 sec	1.25 min	2233 t/h	2144 t/h	2062 t/h	1986 t/h	2109 t/h	2025 t/h	1947 t/h	1875 t/h	

MODEL: 6040 and 6040 FS ● Bucket Size: 28.8 yd³ ● Number of Cycles: 4
● Material Density: 3030 lb/yd³ ● Average Loading Conditions

			100%				95%			
Fill Factor			43.6 tons				41.5 tons			
Load per Bucket			174.5 tons				165.8 tons			
Load per Truck										
Overall Mine Efficiency	Cycle Time		24 sec	26 sec	28 sec	30 sec	24 sec	26 sec	28 sec	30 sec
	Truck Spotting		0.40 min	0.43 min	0.47 min	0.50 min	0.40 min	0.43 min	0.47 min	0.50 min
83% = maximum 50 min/hour	30 sec	0.50 min	4995 tons/h	4715 tons/h	4465 tons/h	4240 tons/h	4745 tons/h	4479 tons/h	4242 tons/h	4028 tons/h
	45 sec	0.75 min	4368 tons/h	4152 tons/h	3957 tons/h	3779 tons/h	4149 tons/h	3944 tons/h	3759 tons/h	3590 tons/h
	60 sec	1.00 min	3880 tons/h	3709 tons/h	3552 tons/h	3408 tons/h	3686 tons/h	3524 tons/h	3375 tons/h	3238 tons/h
	75 sec	1.25 min	3491 tons/h	3351 tons/h	3223 tons/h	3104 tons/h	3316 tons/h	3184 tons/h	3062 tons/h	2949 tons/h
80%	30 sec	0.50 min	4815 tons/h	4545 tons/h	4303 tons/h	4087 tons/h	4574 tons/h	4317 tons/h	4088 tons/h	3882 tons/h
	45 sec	0.75 min	4210 tons/h	4002 tons/h	3814 tons/h	3642 tons/h	3999 tons/h	3802 tons/h	3623 tons/h	3460 tons/h
	60 sec	1.00 min	3740 tons/h	3575 tons/h	3424 tons/h	3285 tons/h	3553 tons/h	3396 tons/h	3253 tons/h	3121 tons/h
	75 sec	1.25 min	3364 tons/h	3230 tons/h	3107 tons/h	2992 tons/h	3196 tons/h	3069 tons/h	2951 tons/h	2842 tons/h
75%	30 sec	0.50 min	4514 tons/h	4261 tons/h	4034 tons/h	3831 tons/h	4288 tons/h	4048 tons/h	3833 tons/h	3640 tons/h
	45 sec	0.75 min	3947 tons/h	3752 tons/h	3575 tons/h	3415 tons/h	3749 tons/h	3564 tons/h	3397 tons/h	3244 tons/h
	60 sec	1.00 min	3506 tons/h	3352 tons/h	3210 tons/h	3080 tons/h	3331 tons/h	3184 tons/h	3049 tons/h	2926 tons/h
	75 sec	1.25 min	3154 tons/h	3028 tons/h	2912 tons/h	2805 tons/h	2996 tons/h	2877 tons/h	2767 tons/h	2665 tons/h
70%	30 sec	0.50 min	4213 tons/h	3977 tons/h	3766 tons/h	3576 tons/h	4002 tons/h	3778 tons/h	3577 tons/h	3397 tons/h
	45 sec	0.75 min	3684 tons/h	3502 tons/h	3337 tons/h	3187 tons/h	3499 tons/h	3327 tons/h	3170 tons/h	3028 tons/h
	60 sec	1.00 min	3272 tons/h	3128 tons/h	2996 tons/h	2875 tons/h	3109 tons/h	2972 tons/h	2846 tons/h	2731 tons/h
	75 sec	1.25 min	2944 tons/h	2827 tons/h	2718 tons/h	2618 tons/h	2797 tons/h	2685 tons/h	2582 tons/h	2487 tons/h
65%	30 sec	0.50 min	3912 tons/h	3693 tons/h	3497 tons/h	3320 tons/h	3716 tons/h	3508 tons/h	3322 tons/h	3154 tons/h
	45 sec	0.75 min	3420 tons/h	3252 tons/h	3099 tons/h	2959 tons/h	3249 tons/h	3089 tons/h	2944 tons/h	2811 tons/h
	60 sec	1.00 min	3039 tons/h	2905 tons/h	2782 tons/h	2669 tons/h	2887 tons/h	2759 tons/h	2643 tons/h	2536 tons/h
	75 sec	1.25 min	2734 tons/h	2625 tons/h	2524 tons/h	2431 tons/h	2597 tons/h	2493 tons/h	2398 tons/h	2309 tons/h

			90%				85%			
Fill Factor			39.3 tons				37.1 tons			
Load per Bucket			157.1 tons				148.3 tons			
Load per Truck										
Overall Mine Efficiency	Cycle Time		24 sec	26 sec	28 sec	30 sec	24 sec	26 sec	28 sec	30 sec
	Truck Spotting		0.40 min	0.43 min	0.47 min	0.50 min	0.40 min	0.43 min	0.47 min	0.50 min
83% = maximum 50 min/hour	30 sec	0.50 min	4496 tons/h	4244 tons/h	4018 tons/h	3816 tons/h	4246 tons/h	4008 tons/h	3795 tons/h	3604 tons/h
	45 sec	0.75 min	3931 tons/h	3737 tons/h	3561 tons/h	3401 tons/h	3712 tons/h	3529 tons/h	3363 tons/h	3212 tons/h
	60 sec	1.00 min	3492 tons/h	3338 tons/h	3197 tons/h	3068 tons/h	3298 tons/h	3153 tons/h	3020 tons/h	2897 tons/h
	75 sec	1.25 min	3142 tons/h	3016 tons/h	2901 tons/h	2794 tons/h	2967 tons/h	2849 tons/h	2740 tons/h	2638 tons/h
80%	30 sec	0.50 min	4333 tons/h	4090 tons/h	3873 tons/h	3678 tons/h	4092 tons/h	3863 tons/h	3658 tons/h	3474 tons/h
	45 sec	0.75 min	3789 tons/h	3602 tons/h	3432 tons/h	3278 tons/h	3578 tons/h	3402 tons/h	3242 tons/h	3096 tons/h
	60 sec	1.00 min	3366 tons/h	3217 tons/h	3082 tons/h	2957 tons/h	3179 tons/h	3039 tons/h	2910 tons/h	2792 tons/h
	75 sec	1.25 min	3028 tons/h	2907 tons/h	2796 tons/h	2693 tons/h	2860 tons/h	2746 tons/h	2641 tons/h	2543 tons/h
75%	30 sec	0.50 min	4062 tons/h	3835 tons/h	3631 tons/h	3448 tons/h	3837 tons/h	3622 tons/h	3429 tons/h	3256 tons/h
	45 sec	0.75 min	3552 tons/h	3377 tons/h	3218 tons/h	3073 tons/h	3355 tons/h	3189 tons/h	3039 tons/h	2902 tons/h
	60 sec	1.00 min	3156 tons/h	3016 tons/h	2889 tons/h	2772 tons/h	2980 tons/h	2849 tons/h	2728 tons/h	2618 tons/h
	75 sec	1.25 min	2839 tons/h	2726 tons/h	2621 tons/h	2524 tons/h	2681 tons/h	2574 tons/h	2476 tons/h	2384 tons/h
70%	30 sec	0.50 min	3791 tons/h	3579 tons/h	3389 tons/h	3218 tons/h	3581 tons/h	3380 tons/h	3201 tons/h	3039 tons/h
	45 sec	0.75 min	3315 tons/h	3152 tons/h	3003 tons/h	2868 tons/h	3131 tons/h	2976 tons/h	2836 tons/h	2709 tons/h
	60 sec	1.00 min	2945 tons/h	2815 tons/h	2696 tons/h	2587 tons/h	2782 tons/h	2659 tons/h	2547 tons/h	2443 tons/h
	75 sec	1.25 min	2649 tons/h	2544 tons/h	2446 tons/h	2356 tons/h	2502 tons/h	2403 tons/h	2311 tons/h	2225 tons/h
65%	30 sec	0.50 min	3521 tons/h	3323 tons/h	3147 tons/h	2988 tons/h	3325 tons/h	3139 tons/h	2972 tons/h	2822 tons/h
	45 sec	0.75 min	3078 tons/h	2926 tons/h	2789 tons/h	2663 tons/h	2907 tons/h	2764 tons/h	2634 tons/h	2515 tons/h
	60 sec	1.00 min	2735 tons/h	2614 tons/h	2504 tons/h	2402 tons/h	2583 tons/h	2469 tons/h	2365 tons/h	2269 tons/h
	75 sec	1.25 min	2460 tons/h	2362 tons/h	2272 tons/h	2188 tons/h	2324 tons/h	2231 tons/h	2145 tons/h	2066 tons/h

MODEL: 6050 ● **Bucket Size: 28.0 m³** ● **Number of Cycles: 4**
 ● **Material Density: 1.80 t/m³** ● **Average Loading Conditions**

		Fill Factor		100%				95%			
		Load per Bucket		50.4 t				47.9 t			
		Load per Truck		202 t				192 t			
Overall Mine Efficiency	Truck Spotting	Cycle Time		25 sec	27 sec	29 sec	31 sec	25 sec	27 sec	29 sec	31 sec
		30 sec	0.50 min	5604 t/h	5298 t/h	5024 t/h	4777 t/h	5323 t/h	5033 t/h	4773 t/h	4538 t/h
83% = maximum 50 min/hour	45 sec	0.75 min	4917 t/h	4681 t/h	4465 t/h	4269 t/h	4672 t/h	4446 t/h	4242 t/h	4056 t/h	
	60 sec	1.00 min	4381 t/h	4192 t/h	4019 t/h	3859 t/h	4162 t/h	3982 t/h	3818 t/h	3666 t/h	
	75 sec	1.25 min	3950 t/h	3796 t/h	3653 t/h	3521 t/h	3753 t/h	3606 t/h	3470 t/h	3345 t/h	
	30 sec	0.50 min	5401 t/h	5106 t/h	4842 t/h	4604 t/h	5131 t/h	4851 t/h	4600 t/h	4374 t/h	
80%	45 sec	0.75 min	4740 t/h	4511 t/h	4304 t/h	4115 t/h	4503 t/h	4286 t/h	4089 t/h	3909 t/h	
	60 sec	1.00 min	4223 t/h	4040 t/h	3873 t/h	3719 t/h	4011 t/h	3838 t/h	3680 t/h	3533 t/h	
	75 sec	1.25 min	3807 t/h	3659 t/h	3521 t/h	3393 t/h	3617 t/h	3476 t/h	3345 t/h	3224 t/h	
	30 sec	0.50 min	5063 t/h	4787 t/h	4540 t/h	4317 t/h	4810 t/h	4548 t/h	4313 t/h	4101 t/h	
75%	45 sec	0.75 min	4443 t/h	4229 t/h	4035 t/h	3858 t/h	4221 t/h	4018 t/h	3833 t/h	3665 t/h	
	60 sec	1.00 min	3959 t/h	3788 t/h	3631 t/h	3487 t/h	3761 t/h	3598 t/h	3450 t/h	3313 t/h	
	75 sec	1.25 min	3569 t/h	3430 t/h	3301 t/h	3181 t/h	3391 t/h	3258 t/h	3136 t/h	3022 t/h	
	30 sec	0.50 min	4726 t/h	4468 t/h	4237 t/h	4029 t/h	4490 t/h	4245 t/h	4025 t/h	3827 t/h	
70%	45 sec	0.75 min	4147 t/h	3947 t/h	3766 t/h	3601 t/h	3940 t/h	3750 t/h	3578 t/h	3420 t/h	
	60 sec	1.00 min	3695 t/h	3535 t/h	3389 t/h	3255 t/h	3510 t/h	3359 t/h	3220 t/h	3092 t/h	
	75 sec	1.25 min	3331 t/h	3201 t/h	3081 t/h	2969 t/h	3165 t/h	3041 t/h	2927 t/h	2821 t/h	
	30 sec	0.50 min	4388 t/h	4149 t/h	3934 t/h	3741 t/h	4169 t/h	3942 t/h	3738 t/h	3554 t/h	
65%	45 sec	0.75 min	3851 t/h	3665 t/h	3497 t/h	3343 t/h	3658 t/h	3482 t/h	3322 t/h	3176 t/h	
	60 sec	1.00 min	3431 t/h	3283 t/h	3147 t/h	3022 t/h	3259 t/h	3119 t/h	2990 t/h	2871 t/h	
	75 sec	1.25 min	3093 t/h	2973 t/h	2861 t/h	2757 t/h	2939 t/h	2824 t/h	2718 t/h	2619 t/h	

		Fill Factor		90%				85%			
		Load per Bucket		45.4 t				42.8 t			
		Load per Truck		181 t				171 t			
Overall Mine Efficiency	Truck Spotting	Cycle Time		25 sec	27 sec	29 sec	31 sec	25 sec	27 sec	29 sec	31 sec
		30 sec	0.50 min	5043 t/h	4768 t/h	4522 t/h	4299 t/h	4763 t/h	4503 t/h	4270 t/h	4060 t/h
83% = maximum 50 min/hour	45 sec	0.75 min	4426 t/h	4212 t/h	4019 t/h	3842 t/h	4180 t/h	3978 t/h	3796 t/h	3629 t/h	
	60 sec	1.00 min	3943 t/h	3773 t/h	3617 t/h	3473 t/h	3724 t/h	3563 t/h	3416 t/h	3280 t/h	
	75 sec	1.25 min	3555 t/h	3416 t/h	3288 t/h	3169 t/h	3358 t/h	3226 t/h	3105 t/h	2993 t/h	
	30 sec	0.50 min	4861 t/h	4596 t/h	4358 t/h	4144 t/h	4591 t/h	4341 t/h	4116 t/h	3914 t/h	
80%	45 sec	0.75 min	4266 t/h	4060 t/h	3874 t/h	3703 t/h	4029 t/h	3835 t/h	3658 t/h	3498 t/h	
	60 sec	1.00 min	3800 t/h	3636 t/h	3486 t/h	3348 t/h	3589 t/h	3434 t/h	3292 t/h	3162 t/h	
	75 sec	1.25 min	3427 t/h	3293 t/h	3169 t/h	3054 t/h	3236 t/h	3110 t/h	2993 t/h	2884 t/h	
	30 sec	0.50 min	4557 t/h	4309 t/h	4086 t/h	3885 t/h	4304 t/h	4069 t/h	3859 t/h	3669 t/h	
75%	45 sec	0.75 min	3999 t/h	3806 t/h	3631 t/h	3472 t/h	3777 t/h	3595 t/h	3430 t/h	3279 t/h	
	60 sec	1.00 min	3563 t/h	3409 t/h	3268 t/h	3138 t/h	3365 t/h	3220 t/h	3087 t/h	2964 t/h	
	75 sec	1.25 min	3212 t/h	3087 t/h	2971 t/h	2863 t/h	3034 t/h	2915 t/h	2806 t/h	2704 t/h	
	30 sec	0.50 min	4253 t/h	4021 t/h	3813 t/h	3626 t/h	4017 t/h	3798 t/h	3602 t/h	3424 t/h	
70%	45 sec	0.75 min	3732 t/h	3553 t/h	3389 t/h	3240 t/h	3525 t/h	3355 t/h	3201 t/h	3060 t/h	
	60 sec	1.00 min	3325 t/h	3182 t/h	3050 t/h	2929 t/h	3141 t/h	3005 t/h	2881 t/h	2766 t/h	
	75 sec	1.25 min	2998 t/h	2881 t/h	2773 t/h	2672 t/h	2832 t/h	2721 t/h	2619 t/h	2524 t/h	
	30 sec	0.50 min	3949 t/h	3734 t/h	3541 t/h	3367 t/h	3730 t/h	3527 t/h	3344 t/h	3180 t/h	
65%	45 sec	0.75 min	3466 t/h	3299 t/h	3147 t/h	3009 t/h	3273 t/h	3116 t/h	2972 t/h	2842 t/h	
	60 sec	1.00 min	3088 t/h	2955 t/h	2832 t/h	2720 t/h	2916 t/h	2790 t/h	2675 t/h	2569 t/h	
	75 sec	1.25 min	2784 t/h	2675 t/h	2575 t/h	2481 t/h	2629 t/h	2527 t/h	2432 t/h	2344 t/h	

MODEL: 6050 ● Bucket Size: 36.6 yd³ ● Number of Cycles: 4
● Material Density: 3030 lb/yd³ ● Average Loading Conditions

			100%				95%			
Fill Factor			55.4 tons				52.7 tons			
Load per Bucket			221.8 tons				210.7 tons			
Load per Truck										
Overall Mine Efficiency	Cycle Time		25 sec	27 sec	29 sec	31 sec	25 sec	27 sec	29 sec	31 sec
	Truck Spotting		0.42 min	0.45 min	0.48 min	0.52 min	0.42 min	0.45 min	0.48 min	0.52 min
83% = maximum 50 min/hour	30 sec	0.50 min	6165 tons/h	5829 tons/h	5527 tons/h	5256 tons/h	5857 tons/h	5537 tons/h	5251 tons/h	4993 tons/h
	45 sec	0.75 min	5410 tons/h	5149 tons/h	4913 tons/h	4697 tons/h	5140 tons/h	4892 tons/h	4667 tons/h	4462 tons/h
	60 sec	1.00 min	4820 tons/h	4612 tons/h	4421 tons/h	4246 tons/h	4579 tons/h	4381 tons/h	4200 tons/h	4033 tons/h
	75 sec	1.25 min	4346 tons/h	4176 tons/h	4019 tons/h	3873 tons/h	4128 tons/h	3967 tons/h	3818 tons/h	3680 tons/h
80%	30 sec	0.50 min	5942 tons/h	5618 tons/h	5328 tons/h	5066 tons/h	5645 tons/h	5337 tons/h	5061 tons/h	4812 tons/h
	45 sec	0.75 min	5214 tons/h	4963 tons/h	4735 tons/h	4527 tons/h	4954 tons/h	4715 tons/h	4498 tons/h	4301 tons/h
	60 sec	1.00 min	4646 tons/h	4445 tons/h	4261 tons/h	4092 tons/h	4413 tons/h	4223 tons/h	4048 tons/h	3887 tons/h
	75 sec	1.25 min	4189 tons/h	4025 tons/h	3874 tons/h	3733 tons/h	3979 tons/h	3824 tons/h	3680 tons/h	3547 tons/h
75%	30 sec	0.50 min	5571 tons/h	5267 tons/h	4995 tons/h	4749 tons/h	5292 tons/h	5004 tons/h	4745 tons/h	4512 tons/h
	45 sec	0.75 min	4889 tons/h	4653 tons/h	4439 tons/h	4244 tons/h	4644 tons/h	4420 tons/h	4217 tons/h	4032 tons/h
	60 sec	1.00 min	4355 tons/h	4167 tons/h	3995 tons/h	3836 tons/h	4138 tons/h	3959 tons/h	3795 tons/h	3645 tons/h
	75 sec	1.25 min	3927 tons/h	3773 tons/h	3632 tons/h	3500 tons/h	3731 tons/h	3585 tons/h	3450 tons/h	3325 tons/h
70%	30 sec	0.50 min	5199 tons/h	4916 tons/h	4662 tons/h	4432 tons/h	4939 tons/h	4670 tons/h	4429 tons/h	4211 tons/h
	45 sec	0.75 min	4563 tons/h	4343 tons/h	4143 tons/h	3961 tons/h	4335 tons/h	4126 tons/h	3936 tons/h	3763 tons/h
	60 sec	1.00 min	4065 tons/h	3890 tons/h	3729 tons/h	3581 tons/h	3862 tons/h	3695 tons/h	3542 tons/h	3402 tons/h
	75 sec	1.25 min	3665 tons/h	3522 tons/h	3389 tons/h	3267 tons/h	3482 tons/h	3346 tons/h	3220 tons/h	3103 tons/h
65%	30 sec	0.50 min	4828 tons/h	4565 tons/h	4329 tons/h	4116 tons/h	4587 tons/h	4336 tons/h	4112 tons/h	3910 tons/h
	45 sec	0.75 min	4237 tons/h	4033 tons/h	3847 tons/h	3678 tons/h	4025 tons/h	3831 tons/h	3655 tons/h	3494 tons/h
	60 sec	1.00 min	3775 tons/h	3612 tons/h	3462 tons/h	3325 tons/h	3586 tons/h	3431 tons/h	3289 tons/h	3159 tons/h
	75 sec	1.25 min	3403 tons/h	3270 tons/h	3147 tons/h	3033 tons/h	3233 tons/h	3107 tons/h	2990 tons/h	2882 tons/h

			90%				85%			
Fill Factor			49.9 tons				47.1 tons			
Load per Bucket			199.6 tons				188.5 tons			
Load per Truck										
Overall Mine Efficiency	Cycle Time		25 sec	27 sec	29 sec	31 sec	25 sec	27 sec	29 sec	31 sec
	Truck Spotting		0.42 min	0.45 min	0.48 min	0.52 min	0.42 min	0.45 min	0.48 min	0.52 min
83% = maximum 50 min/hour	30 sec	0.50 min	5548 tons/h	5246 tons/h	4975 tons/h	4730 tons/h	5240 tons/h	4954 tons/h	4698 tons/h	4467 tons/h
	45 sec	0.75 min	4869 tons/h	4634 tons/h	4421 tons/h	4227 tons/h	4599 tons/h	4377 tons/h	4176 tons/h	3992 tons/h
	60 sec	1.00 min	4338 tons/h	4151 tons/h	3979 tons/h	3821 tons/h	4097 tons/h	3920 tons/h	3758 tons/h	3609 tons/h
	75 sec	1.25 min	3911 tons/h	3758 tons/h	3617 tons/h	3486 tons/h	3694 tons/h	3550 tons/h	3416 tons/h	3292 tons/h
80%	30 sec	0.50 min	5348 tons/h	5056 tons/h	4795 tons/h	4559 tons/h	5051 tons/h	4775 tons/h	4528 tons/h	4306 tons/h
	45 sec	0.75 min	4693 tons/h	4467 tons/h	4262 tons/h	4074 tons/h	4432 tons/h	4219 tons/h	4025 tons/h	3848 tons/h
	60 sec	1.00 min	4181 tons/h	4001 tons/h	3835 tons/h	3683 tons/h	3949 tons/h	3778 tons/h	3622 tons/h	3478 tons/h
	75 sec	1.25 min	3770 tons/h	3623 tons/h	3486 tons/h	3360 tons/h	3560 tons/h	3421 tons/h	3293 tons/h	3173 tons/h
75%	30 sec	0.50 min	5014 tons/h	4740 tons/h	4495 tons/h	4274 tons/h	4735 tons/h	4477 tons/h	4245 tons/h	4037 tons/h
	45 sec	0.75 min	4400 tons/h	4188 tons/h	3995 tons/h	3820 tons/h	4155 tons/h	3955 tons/h	3773 tons/h	3608 tons/h
	60 sec	1.00 min	3920 tons/h	3751 tons/h	3595 tons/h	3453 tons/h	3702 tons/h	3542 tons/h	3396 tons/h	3261 tons/h
	75 sec	1.25 min	3534 tons/h	3396 tons/h	3268 tons/h	3150 tons/h	3338 tons/h	3207 tons/h	3087 tons/h	2975 tons/h
70%	30 sec	0.50 min	4679 tons/h	4424 tons/h	4195 tons/h	3989 tons/h	4419 tons/h	4178 tons/h	3962 tons/h	3768 tons/h
	45 sec	0.75 min	4106 tons/h	3909 tons/h	3729 tons/h	3565 tons/h	3878 tons/h	3691 tons/h	3522 tons/h	3367 tons/h
	60 sec	1.00 min	3658 tons/h	3501 tons/h	3356 tons/h	3223 tons/h	3455 tons/h	3306 tons/h	3169 tons/h	3043 tons/h
	75 sec	1.25 min	3299 tons/h	3170 tons/h	3051 tons/h	2940 tons/h	3115 tons/h	2994 tons/h	2881 tons/h	2777 tons/h
65%	30 sec	0.50 min	4345 tons/h	4108 tons/h	3896 tons/h	3704 tons/h	4104 tons/h	3880 tons/h	3679 tons/h	3498 tons/h
	45 sec	0.75 min	3813 tons/h	3629 tons/h	3463 tons/h	3310 tons/h	3601 tons/h	3428 tons/h	3270 tons/h	3127 tons/h
	60 sec	1.00 min	3397 tons/h	3251 tons/h	3116 tons/h	2992 tons/h	3208 tons/h	3070 tons/h	2943 tons/h	2826 tons/h
	75 sec	1.25 min	3063 tons/h	2943 tons/h	2833 tons/h	2730 tons/h	2893 tons/h	2780 tons/h	2675 tons/h	2578 tons/h

MODEL: 6050 FS ● **Bucket Size: 26.0 m³** ● **Number of Cycles: 4**
 ● **Material Density: 1.80 t/m³** ● **Average Loading Conditions**

		Fill Factor		100%				95%			
		Load per Bucket		46.8 t				44.5 t			
		Load per Truck		187 t				178 t			
Overall Mine Efficiency	Truck Spotting	Cycle Time		25 sec	27 sec	29 sec	31 sec	25 sec	27 sec	29 sec	31 sec
		30 sec	0.50 min	5203 t/h	4920 t/h	4665 t/h	4436 t/h	4943 t/h	4674 t/h	4432 t/h	4214 t/h
83% = maximum 50 min/hour	45 sec	0.75 min	4566 t/h	4346 t/h	4146 t/h	3964 t/h	4338 t/h	4129 t/h	3939 t/h	3766 t/h	
	60 sec	1.00 min	4068 t/h	3893 t/h	3732 t/h	3583 t/h	3865 t/h	3698 t/h	3545 t/h	3404 t/h	
	75 sec	1.25 min	3668 t/h	3525 t/h	3392 t/h	3269 t/h	3484 t/h	3348 t/h	3222 t/h	3106 t/h	
	30 sec	0.50 min	5015 t/h	4742 t/h	4497 t/h	4275 t/h	4764 t/h	4505 t/h	4272 t/h	4062 t/h	
80%	45 sec	0.75 min	4401 t/h	4189 t/h	3997 t/h	3821 t/h	4181 t/h	3980 t/h	3797 t/h	3630 t/h	
	60 sec	1.00 min	3921 t/h	3752 t/h	3597 t/h	3454 t/h	3725 t/h	3564 t/h	3417 t/h	3281 t/h	
	75 sec	1.25 min	3535 t/h	3397 t/h	3269 t/h	3151 t/h	3359 t/h	3227 t/h	3106 t/h	2993 t/h	
	30 sec	0.50 min	4702 t/h	4445 t/h	4216 t/h	4008 t/h	4467 t/h	4223 t/h	4005 t/h	3808 t/h	
75%	45 sec	0.75 min	4126 t/h	3927 t/h	3747 t/h	3582 t/h	3920 t/h	3731 t/h	3559 t/h	3403 t/h	
	60 sec	1.00 min	3676 t/h	3517 t/h	3372 t/h	3238 t/h	3492 t/h	3341 t/h	3203 t/h	3076 t/h	
	75 sec	1.25 min	3314 t/h	3185 t/h	3065 t/h	2954 t/h	3149 t/h	3026 t/h	2912 t/h	2806 t/h	
	30 sec	0.50 min	4388 t/h	4149 t/h	3934 t/h	3741 t/h	4169 t/h	3942 t/h	3738 t/h	3554 t/h	
70%	45 sec	0.75 min	3851 t/h	3665 t/h	3497 t/h	3343 t/h	3658 t/h	3482 t/h	3322 t/h	3176 t/h	
	60 sec	1.00 min	3431 t/h	3283 t/h	3147 t/h	3022 t/h	3259 t/h	3119 t/h	2990 t/h	2871 t/h	
	75 sec	1.25 min	3093 t/h	2973 t/h	2861 t/h	2757 t/h	2939 t/h	2824 t/h	2718 t/h	2619 t/h	
	30 sec	0.50 min	4075 t/h	3853 t/h	3653 t/h	3474 t/h	3871 t/h	3660 t/h	3471 t/h	3300 t/h	
65%	45 sec	0.75 min	3576 t/h	3404 t/h	3247 t/h	3105 t/h	3397 t/h	3233 t/h	3085 t/h	2949 t/h	
	60 sec	1.00 min	3186 t/h	3048 t/h	2922 t/h	2806 t/h	3027 t/h	2896 t/h	2776 t/h	2666 t/h	
	75 sec	1.25 min	2872 t/h	2760 t/h	2656 t/h	2560 t/h	2729 t/h	2622 t/h	2524 t/h	2432 t/h	

		Fill Factor		90%				85%			
		Load per Bucket		42.1 t				39.8 t			
		Load per Truck		168 t				159 t			
Overall Mine Efficiency	Truck Spotting	Cycle Time		25 sec	27 sec	29 sec	31 sec	25 sec	27 sec	29 sec	31 sec
		30 sec	0.50 min	4683 t/h	4428 t/h	4199 t/h	3992 t/h	4423 t/h	4182 t/h	3965 t/h	3770 t/h
83% = maximum 50 min/hour	45 sec	0.75 min	4110 t/h	3912 t/h	3732 t/h	3568 t/h	3881 t/h	3694 t/h	3524 t/h	3370 t/h	
	60 sec	1.00 min	3661 t/h	3503 t/h	3358 t/h	3225 t/h	3458 t/h	3309 t/h	3172 t/h	3046 t/h	
	75 sec	1.25 min	3301 t/h	3172 t/h	3053 t/h	2942 t/h	3118 t/h	2996 t/h	2883 t/h	2779 t/h	
	30 sec	0.50 min	4514 t/h	4268 t/h	4047 t/h	3848 t/h	4263 t/h	4030 t/h	3822 t/h	3634 t/h	
80%	45 sec	0.75 min	3961 t/h	3770 t/h	3597 t/h	3439 t/h	3741 t/h	3561 t/h	3397 t/h	3248 t/h	
	60 sec	1.00 min	3529 t/h	3377 t/h	3237 t/h	3108 t/h	3333 t/h	3189 t/h	3057 t/h	2936 t/h	
	75 sec	1.25 min	3182 t/h	3057 t/h	2943 t/h	2836 t/h	3005 t/h	2888 t/h	2779 t/h	2678 t/h	
	30 sec	0.50 min	4232 t/h	4001 t/h	3794 t/h	3607 t/h	3997 t/h	3779 t/h	3583 t/h	3407 t/h	
75%	45 sec	0.75 min	3713 t/h	3535 t/h	3372 t/h	3224 t/h	3507 t/h	3338 t/h	3185 t/h	3045 t/h	
	60 sec	1.00 min	3308 t/h	3166 t/h	3035 t/h	2914 t/h	3125 t/h	2990 t/h	2866 t/h	2752 t/h	
	75 sec	1.25 min	2983 t/h	2866 t/h	2759 t/h	2659 t/h	2817 t/h	2707 t/h	2605 t/h	2511 t/h	
	30 sec	0.50 min	3949 t/h	3734 t/h	3541 t/h	3367 t/h	3730 t/h	3527 t/h	3344 t/h	3180 t/h	
70%	45 sec	0.75 min	3466 t/h	3299 t/h	3147 t/h	3009 t/h	3273 t/h	3116 t/h	2972 t/h	2842 t/h	
	60 sec	1.00 min	3088 t/h	2955 t/h	2832 t/h	2720 t/h	2916 t/h	2790 t/h	2675 t/h	2569 t/h	
	75 sec	1.25 min	2784 t/h	2675 t/h	2575 t/h	2481 t/h	2629 t/h	2527 t/h	2432 t/h	2344 t/h	
	30 sec	0.50 min	3667 t/h	3467 t/h	3288 t/h	3126 t/h	3464 t/h	3275 t/h	3105 t/h	2953 t/h	
65%	45 sec	0.75 min	3218 t/h	3063 t/h	2922 t/h	2794 t/h	3040 t/h	2893 t/h	2760 t/h	2639 t/h	
	60 sec	1.00 min	2867 t/h	2744 t/h	2630 t/h	2526 t/h	2708 t/h	2591 t/h	2484 t/h	2385 t/h	
	75 sec	1.25 min	2585 t/h	2484 t/h	2391 t/h	2304 t/h	2442 t/h	2346 t/h	2258 t/h	2176 t/h	

MODEL: 6050 FS ● Bucket Size: 34.0 yd³ ● Number of Cycles: 4
● Material Density: 3030 lb/yd³ ● Average Loading Conditions

			100%				95%			
Fill Factor			51.5 tons				48.9 tons			
Load per Bucket			206.0 tons				195.7 tons			
Load per Truck										
Overall Mine Efficiency	Cycle Time		25 sec	27 sec	29 sec	31 sec	25 sec	27 sec	29 sec	31 sec
	Truck Spotting		0.42 min	0.45 min	0.48 min	0.52 min	0.42 min	0.45 min	0.48 min	0.52 min
83% = maximum 50 min/hour	30 sec	0.50 min	5727 tons/h	5415 tons/h	5135 tons/h	4882 tons/h	5441 tons/h	5144 tons/h	4878 tons/h	4638 tons/h
	45 sec	0.75 min	5026 tons/h	4784 tons/h	4564 tons/h	4363 tons/h	4774 tons/h	4544 tons/h	4336 tons/h	4145 tons/h
	60 sec	1.00 min	4477 tons/h	4284 tons/h	4107 tons/h	3944 tons/h	4254 tons/h	4070 tons/h	3902 tons/h	3747 tons/h
	75 sec	1.25 min	4037 tons/h	3879 tons/h	3733 tons/h	3598 tons/h	3835 tons/h	3685 tons/h	3547 tons/h	3418 tons/h
80%	30 sec	0.50 min	5520 tons/h	5219 tons/h	4949 tons/h	4706 tons/h	5244 tons/h	4958 tons/h	4702 tons/h	4470 tons/h
	45 sec	0.75 min	4844 tons/h	4611 tons/h	4399 tons/h	4205 tons/h	4602 tons/h	4380 tons/h	4179 tons/h	3995 tons/h
	60 sec	1.00 min	4316 tons/h	4129 tons/h	3959 tons/h	3801 tons/h	4100 tons/h	3923 tons/h	3761 tons/h	3611 tons/h
	75 sec	1.25 min	3891 tons/h	3739 tons/h	3599 tons/h	3468 tons/h	3697 tons/h	3552 tons/h	3419 tons/h	3295 tons/h
75%	30 sec	0.50 min	5175 tons/h	4893 tons/h	4640 tons/h	4412 tons/h	4916 tons/h	4648 tons/h	4408 tons/h	4191 tons/h
	45 sec	0.75 min	4541 tons/h	4323 tons/h	4124 tons/h	3943 tons/h	4314 tons/h	4106 tons/h	3918 tons/h	3746 tons/h
	60 sec	1.00 min	4046 tons/h	3871 tons/h	3711 tons/h	3564 tons/h	3844 tons/h	3678 tons/h	3526 tons/h	3386 tons/h
	75 sec	1.25 min	3648 tons/h	3505 tons/h	3374 tons/h	3251 tons/h	3466 tons/h	3330 tons/h	3205 tons/h	3089 tons/h
70%	30 sec	0.50 min	4830 tons/h	4567 tons/h	4330 tons/h	4118 tons/h	4588 tons/h	4338 tons/h	4114 tons/h	3912 tons/h
	45 sec	0.75 min	4239 tons/h	4034 tons/h	3849 tons/h	3680 tons/h	4027 tons/h	3833 tons/h	3656 tons/h	3496 tons/h
	60 sec	1.00 min	3776 tons/h	3613 tons/h	3464 tons/h	3326 tons/h	3587 tons/h	3433 tons/h	3291 tons/h	3160 tons/h
	75 sec	1.25 min	3405 tons/h	3272 tons/h	3149 tons/h	3035 tons/h	3234 tons/h	3108 tons/h	2991 tons/h	2883 tons/h
65%	30 sec	0.50 min	4485 tons/h	4240 tons/h	4021 tons/h	3823 tons/h	4261 tons/h	4028 tons/h	3820 tons/h	3632 tons/h
	45 sec	0.75 min	3936 tons/h	3746 tons/h	3574 tons/h	3417 tons/h	3739 tons/h	3559 tons/h	3395 tons/h	3246 tons/h
	60 sec	1.00 min	3506 tons/h	3355 tons/h	3216 tons/h	3089 tons/h	3331 tons/h	3187 tons/h	3056 tons/h	2934 tons/h
	75 sec	1.25 min	3162 tons/h	3038 tons/h	2924 tons/h	2818 tons/h	3003 tons/h	2886 tons/h	2778 tons/h	2677 tons/h

			90%				85%			
Fill Factor			46.4 tons				43.8 tons			
Load per Bucket			185.4 tons				175.1 tons			
Load per Truck										
Overall Mine Efficiency	Cycle Time		25 sec	27 sec	29 sec	31 sec	25 sec	27 sec	29 sec	31 sec
	Truck Spotting		0.42 min	0.45 min	0.48 min	0.52 min	0.42 min	0.45 min	0.48 min	0.52 min
83% = maximum 50 min/hour	30 sec	0.50 min	5154 tons/h	4873 tons/h	4621 tons/h	4394 tons/h	4868 tons/h	4602 tons/h	4364 tons/h	4150 tons/h
	45 sec	0.75 min	4523 tons/h	4305 tons/h	4107 tons/h	3927 tons/h	4272 tons/h	4066 tons/h	3879 tons/h	3709 tons/h
	60 sec	1.00 min	4030 tons/h	3856 tons/h	3696 tons/h	3550 tons/h	3806 tons/h	3642 tons/h	3491 tons/h	3352 tons/h
	75 sec	1.25 min	3633 tons/h	3491 tons/h	3360 tons/h	3238 tons/h	3431 tons/h	3297 tons/h	3173 tons/h	3058 tons/h
80%	30 sec	0.50 min	4968 tons/h	4697 tons/h	4454 tons/h	4235 tons/h	4692 tons/h	4436 tons/h	4207 tons/h	4000 tons/h
	45 sec	0.75 min	4360 tons/h	4150 tons/h	3959 tons/h	3785 tons/h	4117 tons/h	3919 tons/h	3739 tons/h	3575 tons/h
	60 sec	1.00 min	3884 tons/h	3716 tons/h	3563 tons/h	3421 tons/h	3668 tons/h	3510 tons/h	3365 tons/h	3231 tons/h
	75 sec	1.25 min	3502 tons/h	3365 tons/h	3239 tons/h	3121 tons/h	3307 tons/h	3178 tons/h	3059 tons/h	2948 tons/h
75%	30 sec	0.50 min	4657 tons/h	4403 tons/h	4176 tons/h	3970 tons/h	4399 tons/h	4159 tons/h	3944 tons/h	3750 tons/h
	45 sec	0.75 min	4087 tons/h	3890 tons/h	3711 tons/h	3548 tons/h	3860 tons/h	3674 tons/h	3505 tons/h	3351 tons/h
	60 sec	1.00 min	3641 tons/h	3484 tons/h	3340 tons/h	3207 tons/h	3439 tons/h	3291 tons/h	3155 tons/h	3029 tons/h
	75 sec	1.25 min	3283 tons/h	3155 tons/h	3036 tons/h	2926 tons/h	3101 tons/h	2980 tons/h	2868 tons/h	2764 tons/h
70%	30 sec	0.50 min	4347 tons/h	4110 tons/h	3897 tons/h	3706 tons/h	4105 tons/h	3882 tons/h	3681 tons/h	3500 tons/h
	45 sec	0.75 min	3815 tons/h	3631 tons/h	3464 tons/h	3312 tons/h	3603 tons/h	3429 tons/h	3272 tons/h	3128 tons/h
	60 sec	1.00 min	3399 tons/h	3252 tons/h	3117 tons/h	2994 tons/h	3210 tons/h	3071 tons/h	2944 tons/h	2827 tons/h
	75 sec	1.25 min	3064 tons/h	2945 tons/h	2834 tons/h	2731 tons/h	2894 tons/h	2781 tons/h	2676 tons/h	2579 tons/h
65%	30 sec	0.50 min	4036 tons/h	3816 tons/h	3619 tons/h	3441 tons/h	3812 tons/h	3604 tons/h	3418 tons/h	3250 tons/h
	45 sec	0.75 min	3542 tons/h	3372 tons/h	3217 tons/h	3075 tons/h	3345 tons/h	3184 tons/h	3038 tons/h	2904 tons/h
	60 sec	1.00 min	3156 tons/h	3020 tons/h	2895 tons/h	2780 tons/h	2980 tons/h	2852 tons/h	2734 tons/h	2625 tons/h
	75 sec	1.25 min	2845 tons/h	2734 tons/h	2631 tons/h	2536 tons/h	2687 tons/h	2582 tons/h	2485 tons/h	2395 tons/h

MODEL: 6060 and 6060 FS ● **Bucket Size: 34.0 m³** ● **Number of Cycles: 4**
 ● **Material Density: 1.80 t/m³** ● **Average Loading Conditions**

		Fill Factor		100%				95%			
		Load per Bucket		61.2 t				58.1 t			
		Load per Truck		245 t				233 t			
Overall Mine Efficiency	Truck Spotting	Cycle Time		26 sec	28 sec	30 sec	32 sec	26 sec	28 sec	30 sec	32 sec
		30 sec	0.50 min	0.43 min	0.47 min	0.50 min	0.53 min	0.43 min	0.47 min	0.50 min	0.53 min
83% = maximum 50 min/hour	30 sec	0.50 min	6614 t/h	6263 t/h	5947 t/h	5661 t/h	6283 t/h	5949 t/h	5650 t/h	5378 t/h	
	45 sec	0.75 min	5824 t/h	5550 t/h	5300 t/h	5073 t/h	5533 t/h	5272 t/h	5035 t/h	4819 t/h	
	60 sec	1.00 min	5202 t/h	4983 t/h	4781 t/h	4595 t/h	4942 t/h	4734 t/h	4542 t/h	4365 t/h	
	75 sec	1.25 min	4701 t/h	4521 t/h	4354 t/h	4199 t/h	4466 t/h	4295 t/h	4136 t/h	3989 t/h	
80%	30 sec	0.50 min	6375 t/h	6036 t/h	5732 t/h	5457 t/h	6056 t/h	5734 t/h	5445 t/h	5184 t/h	
	45 sec	0.75 min	5613 t/h	5349 t/h	5109 t/h	4889 t/h	5333 t/h	5082 t/h	4853 t/h	4645 t/h	
	60 sec	1.00 min	5014 t/h	4803 t/h	4608 t/h	4429 t/h	4764 t/h	4562 t/h	4378 t/h	4207 t/h	
	75 sec	1.25 min	4531 t/h	4357 t/h	4197 t/h	4047 t/h	4304 t/h	4140 t/h	3987 t/h	3845 t/h	
75%	30 sec	0.50 min	5976 t/h	5659 t/h	5374 t/h	5116 t/h	5677 t/h	5376 t/h	5105 t/h	4860 t/h	
	45 sec	0.75 min	5262 t/h	5015 t/h	4790 t/h	4584 t/h	4999 t/h	4764 t/h	4550 t/h	4354 t/h	
	60 sec	1.00 min	4701 t/h	4502 t/h	4320 t/h	4152 t/h	4466 t/h	4277 t/h	4104 t/h	3944 t/h	
	75 sec	1.25 min	4248 t/h	4085 t/h	3934 t/h	3794 t/h	4035 t/h	3881 t/h	3738 t/h	3605 t/h	
70%	30 sec	0.50 min	5578 t/h	5282 t/h	5015 t/h	4775 t/h	5299 t/h	5018 t/h	4765 t/h	4536 t/h	
	45 sec	0.75 min	4912 t/h	4681 t/h	4470 t/h	4278 t/h	4666 t/h	4447 t/h	4247 t/h	4064 t/h	
	60 sec	1.00 min	4388 t/h	4202 t/h	4032 t/h	3875 t/h	4168 t/h	3992 t/h	3830 t/h	3681 t/h	
	75 sec	1.25 min	3965 t/h	3813 t/h	3672 t/h	3541 t/h	3766 t/h	3622 t/h	3488 t/h	3364 t/h	
65%	30 sec	0.50 min	5179 t/h	4904 t/h	4657 t/h	4434 t/h	4920 t/h	4659 t/h	4424 t/h	4212 t/h	
	45 sec	0.75 min	4561 t/h	4346 t/h	4151 t/h	3972 t/h	4333 t/h	4129 t/h	3943 t/h	3774 t/h	
	60 sec	1.00 min	4074 t/h	3902 t/h	3744 t/h	3598 t/h	3870 t/h	3707 t/h	3557 t/h	3418 t/h	
	75 sec	1.25 min	3681 t/h	3540 t/h	3410 t/h	3288 t/h	3497 t/h	3363 t/h	3239 t/h	3124 t/h	

		Fill Factor		90%				85%			
		Load per Bucket		55.1 t				52.0 t			
		Load per Truck		220 t				208 t			
Overall Mine Efficiency	Truck Spotting	Cycle Time		26 sec	28 sec	30 sec	32 sec	26 sec	28 sec	30 sec	32 sec
		30 sec	0.50 min	0.43 min	0.47 min	0.50 min	0.53 min	0.43 min	0.47 min	0.50 min	0.53 min
83% = maximum 50 min/hour	30 sec	0.50 min	5952 t/h	5636 t/h	5352 t/h	5095 t/h	5622 t/h	5323 t/h	5055 t/h	4812 t/h	
	45 sec	0.75 min	5241 t/h	4995 t/h	4770 t/h	4565 t/h	4950 t/h	4717 t/h	4505 t/h	4312 t/h	
	60 sec	1.00 min	4682 t/h	4484 t/h	4303 t/h	4135 t/h	4422 t/h	4235 t/h	4064 t/h	3905 t/h	
	75 sec	1.25 min	4231 t/h	4069 t/h	3919 t/h	3779 t/h	3996 t/h	3843 t/h	3701 t/h	3569 t/h	
80%	30 sec	0.50 min	5737 t/h	5433 t/h	5159 t/h	4911 t/h	5418 t/h	5131 t/h	4872 t/h	4638 t/h	
	45 sec	0.75 min	5052 t/h	4814 t/h	4598 t/h	4400 t/h	4771 t/h	4547 t/h	4343 t/h	4156 t/h	
	60 sec	1.00 min	4513 t/h	4322 t/h	4147 t/h	3986 t/h	4262 t/h	4082 t/h	3917 t/h	3764 t/h	
	75 sec	1.25 min	4078 t/h	3922 t/h	3777 t/h	3642 t/h	3851 t/h	3704 t/h	3567 t/h	3440 t/h	
75%	30 sec	0.50 min	5379 t/h	5093 t/h	4836 t/h	4604 t/h	5080 t/h	4810 t/h	4568 t/h	4348 t/h	
	45 sec	0.75 min	4736 t/h	4513 t/h	4311 t/h	4125 t/h	4473 t/h	4263 t/h	4071 t/h	3896 t/h	
	60 sec	1.00 min	4231 t/h	4052 t/h	3888 t/h	3737 t/h	3996 t/h	3827 t/h	3672 t/h	3529 t/h	
	75 sec	1.25 min	3823 t/h	3677 t/h	3541 t/h	3415 t/h	3611 t/h	3472 t/h	3344 t/h	3225 t/h	
70%	30 sec	0.50 min	5020 t/h	4753 t/h	4514 t/h	4297 t/h	4741 t/h	4489 t/h	4263 t/h	4059 t/h	
	45 sec	0.75 min	4420 t/h	4212 t/h	4023 t/h	3850 t/h	4175 t/h	3978 t/h	3800 t/h	3636 t/h	
	60 sec	1.00 min	3949 t/h	3782 t/h	3629 t/h	3487 t/h	3729 t/h	3572 t/h	3427 t/h	3294 t/h	
	75 sec	1.25 min	3568 t/h	3431 t/h	3305 t/h	3187 t/h	3370 t/h	3241 t/h	3121 t/h	3010 t/h	
65%	30 sec	0.50 min	4661 t/h	4414 t/h	4191 t/h	3990 t/h	4402 t/h	4169 t/h	3959 t/h	3769 t/h	
	45 sec	0.75 min	4105 t/h	3912 t/h	3736 t/h	3575 t/h	3877 t/h	3694 t/h	3528 t/h	3377 t/h	
	60 sec	1.00 min	3667 t/h	3512 t/h	3370 t/h	3238 t/h	3463 t/h	3317 t/h	3182 t/h	3058 t/h	
	75 sec	1.25 min	3313 t/h	3186 t/h	3069 t/h	2960 t/h	3129 t/h	3009 t/h	2898 t/h	2795 t/h	

MODEL: 6060 and 6060 FS ● Bucket Size: 44.5 yd³ ● Number of Cycles: 4
● Material Density: 3030 lb/yd³ ● Average Loading Conditions

			100%				95%			
Fill Factor			674 tons				64.0 tons			
Load per Bucket			269.7 tons				256.2 tons			
Load per Truck										
Overall Mine Efficiency	Cycle Time		26 sec	28 sec	30 sec	32 sec	26 sec	28 sec	30 sec	32 sec
	Truck Spotting		0.43 min	0.47 min	0.50 min	0.53 min	0.43 min	0.47 min	0.50 min	0.53 min
83% = maximum 50 min/hour	30 sec	0.50 min	7285 tons/h	6899 tons/h	6551 tons/h	6237 tons/h	6921 tons/h	6554 tons/h	6223 tons/h	5925 tons/h
	45 sec	0.75 min	6415 tons/h	6114 tons/h	5839 tons/h	5588 tons/h	6095 tons/h	5808 tons/h	5547 tons/h	5308 tons/h
	60 sec	1.00 min	5731 tons/h	5489 tons/h	5266 tons/h	5061 tons/h	5444 tons/h	5214 tons/h	5003 tons/h	4808 tons/h
	75 sec	1.25 min	5178 tons/h	4980 tons/h	4796 tons/h	4626 tons/h	4920 tons/h	4731 tons/h	4556 tons/h	4394 tons/h
80%	30 sec	0.50 min	7022 tons/h	6649 tons/h	6314 tons/h	6011 tons/h	6671 tons/h	6317 tons/h	5999 tons/h	5711 tons/h
	45 sec	0.75 min	6184 tons/h	5893 tons/h	5628 tons/h	5386 tons/h	5874 tons/h	5598 tons/h	5347 tons/h	5117 tons/h
	60 sec	1.00 min	5524 tons/h	5291 tons/h	5076 tons/h	4878 tons/h	5248 tons/h	5026 tons/h	4822 tons/h	4635 tons/h
	75 sec	1.25 min	4991 tons/h	4800 tons/h	4623 tons/h	4458 tons/h	4742 tons/h	4560 tons/h	4392 tons/h	4235 tons/h
75%	30 sec	0.50 min	6583 tons/h	6234 tons/h	5920 tons/h	5636 tons/h	6254 tons/h	5922 tons/h	5624 tons/h	5354 tons/h
	45 sec	0.75 min	5797 tons/h	5524 tons/h	5276 tons/h	5049 tons/h	5507 tons/h	5248 tons/h	5012 tons/h	4797 tons/h
	60 sec	1.00 min	5179 tons/h	4960 tons/h	4759 tons/h	4574 tons/h	4920 tons/h	4712 tons/h	4521 tons/h	4345 tons/h
	75 sec	1.25 min	4679 tons/h	4500 tons/h	4334 tons/h	4180 tons/h	4445 tons/h	4275 tons/h	4117 tons/h	3971 tons/h
70%	30 sec	0.50 min	6144 tons/h	5818 tons/h	5525 tons/h	5260 tons/h	5837 tons/h	5527 tons/h	5249 tons/h	4997 tons/h
	45 sec	0.75 min	5411 tons/h	5156 tons/h	4924 tons/h	4713 tons/h	5140 tons/h	4898 tons/h	4678 tons/h	4477 tons/h
	60 sec	1.00 min	4833 tons/h	4629 tons/h	4442 tons/h	4269 tons/h	4592 tons/h	4398 tons/h	4220 tons/h	4055 tons/h
	75 sec	1.25 min	4367 tons/h	4200 tons/h	4045 tons/h	3901 tons/h	4149 tons/h	3990 tons/h	3843 tons/h	3706 tons/h
65%	30 sec	0.50 min	5705 tons/h	5403 tons/h	5130 tons/h	4884 tons/h	5420 tons/h	5133 tons/h	4874 tons/h	4640 tons/h
	45 sec	0.75 min	5024 tons/h	4788 tons/h	4573 tons/h	4376 tons/h	4773 tons/h	4548 tons/h	4344 tons/h	4157 tons/h
	60 sec	1.00 min	4488 tons/h	4299 tons/h	4124 tons/h	3964 tons/h	4264 tons/h	4084 tons/h	3918 tons/h	3766 tons/h
	75 sec	1.25 min	4055 tons/h	3900 tons/h	3756 tons/h	3622 tons/h	3853 tons/h	3705 tons/h	3568 tons/h	3441 tons/h

			90%				85%			
Fill Factor			60.7 tons				57.3 tons			
Load per Bucket			242.7 tons				229.2 tons			
Load per Truck										
Overall Mine Efficiency	Cycle Time		26 sec	28 sec	30 sec	32 sec	26 sec	28 sec	30 sec	32 sec
	Truck Spotting		0.43 min	0.47 min	0.50 min	0.53 min	0.43 min	0.47 min	0.50 min	0.53 min
83% = maximum 50 min/hour	30 sec	0.50 min	6557 tons/h	6209 tons/h	5896 tons/h	5613 tons/h	6193 tons/h	5864 tons/h	5568 tons/h	5301 tons/h
	45 sec	0.75 min	5774 tons/h	5502 tons/h	5255 tons/h	5029 tons/h	5453 tons/h	5197 tons/h	4963 tons/h	4750 tons/h
	60 sec	1.00 min	5158 tons/h	4940 tons/h	4740 tons/h	4555 tons/h	4871 tons/h	4666 tons/h	4477 tons/h	4302 tons/h
	75 sec	1.25 min	4661 tons/h	4482 tons/h	4317 tons/h	4163 tons/h	4402 tons/h	4233 tons/h	4077 tons/h	3932 tons/h
80%	30 sec	0.50 min	6320 tons/h	5984 tons/h	5683 tons/h	5410 tons/h	5969 tons/h	5652 tons/h	5367 tons/h	5110 tons/h
	45 sec	0.75 min	5565 tons/h	5303 tons/h	5065 tons/h	4847 tons/h	5256 tons/h	5009 tons/h	4784 tons/h	4578 tons/h
	60 sec	1.00 min	4971 tons/h	4761 tons/h	4569 tons/h	4391 tons/h	4695 tons/h	4497 tons/h	4315 tons/h	4147 tons/h
	75 sec	1.25 min	4492 tons/h	4320 tons/h	4161 tons/h	4013 tons/h	4243 tons/h	4080 tons/h	3929 tons/h	3790 tons/h
75%	30 sec	0.50 min	5925 tons/h	5610 tons/h	5328 tons/h	5072 tons/h	5596 tons/h	5299 tons/h	5032 tons/h	4790 tons/h
	45 sec	0.75 min	5217 tons/h	4972 tons/h	4749 tons/h	4544 tons/h	4927 tons/h	4696 tons/h	4485 tons/h	4292 tons/h
	60 sec	1.00 min	4661 tons/h	4464 tons/h	4283 tons/h	4116 tons/h	4402 tons/h	4216 tons/h	4045 tons/h	3888 tons/h
	75 sec	1.25 min	4211 tons/h	4050 tons/h	3901 tons/h	3762 tons/h	3977 tons/h	3825 tons/h	3684 tons/h	3553 tons/h
70%	30 sec	0.50 min	5530 tons/h	5236 tons/h	4972 tons/h	4734 tons/h	5223 tons/h	4945 tons/h	4696 tons/h	4471 tons/h
	45 sec	0.75 min	4870 tons/h	4640 tons/h	4432 tons/h	4241 tons/h	4599 tons/h	4383 tons/h	4186 tons/h	4006 tons/h
	60 sec	1.00 min	4350 tons/h	4166 tons/h	3997 tons/h	3842 tons/h	4108 tons/h	3935 tons/h	3775 tons/h	3628 tons/h
	75 sec	1.25 min	3931 tons/h	3780 tons/h	3641 tons/h	3511 tons/h	3712 tons/h	3570 tons/h	3438 tons/h	3316 tons/h
65%	30 sec	0.50 min	5135 tons/h	4862 tons/h	4617 tons/h	4396 tons/h	4850 tons/h	4592 tons/h	4361 tons/h	4151 tons/h
	45 sec	0.75 min	4522 tons/h	4309 tons/h	4115 tons/h	3938 tons/h	4270 tons/h	4070 tons/h	3887 tons/h	3720 tons/h
	60 sec	1.00 min	4039 tons/h	3869 tons/h	3712 tons/h	3567 tons/h	3815 tons/h	3654 tons/h	3506 tons/h	3369 tons/h
	75 sec	1.25 min	3650 tons/h	3510 tons/h	3381 tons/h	3260 tons/h	3447 tons/h	3315 tons/h	3193 tons/h	3079 tons/h

MODEL: 6090 FS ● **Bucket Size: 52.0 m³** ● **Number of Cycles: 4**
 ● **Material Density: 1.80 t/m³** ● **Average Loading Conditions**

		Fill Factor	100%				95%			
		Load per Bucket	93.6 t				88.9 t			
		Load per Truck	374 t				356 t			
Overall Mine Efficiency	Cycle Time		28 sec	30 sec	32 sec	34 sec	28 sec	30 sec	32 sec	34 sec
	Truck Spotting		0.47 min	0.50 min	0.53 min	0.57 min	0.47 min	0.50 min	0.53 min	0.57 min
83% = maximum 50 min/hour	30 sec	0.50 min	9578 t/h	9095 t/h	8659 t/h	8262 t/h	9099 t/h	8640 t/h	8226 t/h	7849 t/h
	45 sec	0.75 min	8488 t/h	8107 t/h	7758 t/h	7438 t/h	8064 t/h	7701 t/h	7370 t/h	7066 t/h
	60 sec	1.00 min	7621 t/h	7312 t/h	7027 t/h	6764 t/h	7240 t/h	6946 t/h	6676 t/h	6425 t/h
	75 sec	1.25 min	6914 t/h	6659 t/h	6422 t/h	6201 t/h	6568 t/h	6326 t/h	6101 t/h	5891 t/h
80%	30 sec	0.50 min	9232 t/h	8766 t/h	8346 t/h	7964 t/h	8770 t/h	8328 t/h	7928 t/h	7565 t/h
	45 sec	0.75 min	8181 t/h	7814 t/h	7478 t/h	7169 t/h	7772 t/h	7423 t/h	7104 t/h	6811 t/h
	60 sec	1.00 min	7345 t/h	7048 t/h	6773 t/h	6519 t/h	6978 t/h	6695 t/h	6434 t/h	6193 t/h
	75 sec	1.25 min	6664 t/h	6418 t/h	6190 t/h	5977 t/h	6331 t/h	6097 t/h	5880 t/h	5678 t/h
75%	30 sec	0.50 min	8655 t/h	8219 t/h	7824 t/h	7466 t/h	8222 t/h	7808 t/h	7433 t/h	7093 t/h
	45 sec	0.75 min	7670 t/h	7325 t/h	7010 t/h	6721 t/h	7286 t/h	6959 t/h	6660 t/h	6385 t/h
	60 sec	1.00 min	6886 t/h	6607 t/h	6350 t/h	6112 t/h	6542 t/h	6277 t/h	6032 t/h	5806 t/h
	75 sec	1.25 min	6248 t/h	6017 t/h	5803 t/h	5604 t/h	5935 t/h	5716 t/h	5513 t/h	5323 t/h
70%	30 sec	0.50 min	8078 t/h	7671 t/h	7303 t/h	6968 t/h	7674 t/h	7287 t/h	6937 t/h	6620 t/h
	45 sec	0.75 min	7158 t/h	6837 t/h	6543 t/h	6273 t/h	6801 t/h	6495 t/h	6216 t/h	5960 t/h
	60 sec	1.00 min	6427 t/h	6167 t/h	5926 t/h	5704 t/h	6106 t/h	5858 t/h	5630 t/h	5419 t/h
	75 sec	1.25 min	5831 t/h	5616 t/h	5416 t/h	5230 t/h	5540 t/h	5335 t/h	5145 t/h	4968 t/h
65%	30 sec	0.50 min	7501 t/h	7123 t/h	6781 t/h	6470 t/h	7126 t/h	6767 t/h	6442 t/h	6147 t/h
	45 sec	0.75 min	6647 t/h	6349 t/h	6076 t/h	5825 t/h	6315 t/h	6031 t/h	5772 t/h	5534 t/h
	60 sec	1.00 min	5968 t/h	5726 t/h	5503 t/h	5297 t/h	5670 t/h	5440 t/h	5228 t/h	5032 t/h
	75 sec	1.25 min	5415 t/h	5215 t/h	5029 t/h	4856 t/h	5144 t/h	4954 t/h	4778 t/h	4614 t/h

		Fill Factor	90%				85%			
		Load per Bucket	84.2 t				79.6 t			
		Load per Truck	337 t				318 t			
Overall Mine Efficiency	Cycle Time		28 sec	30 sec	32 sec	34 sec	28 sec	30 sec	32 sec	34 sec
	Truck Spotting		0.47 min	0.50 min	0.53 min	0.57 min	0.47 min	0.50 min	0.53 min	0.57 min
83% = maximum 50 min/hour	30 sec	0.50 min	8620 t/h	8186 t/h	7793 t/h	7436 t/h	8141 t/h	7731 t/h	7360 t/h	7023 t/h
	45 sec	0.75 min	7639 t/h	7296 t/h	6982 t/h	6694 t/h	7215 t/h	6891 t/h	6594 t/h	6322 t/h
	60 sec	1.00 min	6859 t/h	6581 t/h	6324 t/h	6087 t/h	6478 t/h	6215 t/h	5973 t/h	5749 t/h
	75 sec	1.25 min	6223 t/h	5993 t/h	5780 t/h	5581 t/h	5877 t/h	5660 t/h	5459 t/h	5271 t/h
80%	30 sec	0.50 min	8309 t/h	7890 t/h	7511 t/h	7167 t/h	7847 t/h	7451 t/h	7094 t/h	6769 t/h
	45 sec	0.75 min	7363 t/h	7032 t/h	6730 t/h	6452 t/h	6954 t/h	6642 t/h	6356 t/h	6094 t/h
	60 sec	1.00 min	6611 t/h	6343 t/h	6096 t/h	5867 t/h	6243 t/h	5990 t/h	5757 t/h	5541 t/h
	75 sec	1.25 min	5998 t/h	5776 t/h	5571 t/h	5379 t/h	5665 t/h	5456 t/h	5261 t/h	5081 t/h
75%	30 sec	0.50 min	7789 t/h	7397 t/h	7042 t/h	6719 t/h	7357 t/h	6986 t/h	6651 t/h	6346 t/h
	45 sec	0.75 min	6903 t/h	6593 t/h	6309 t/h	6049 t/h	6519 t/h	6226 t/h	5959 t/h	5713 t/h
	60 sec	1.00 min	6197 t/h	5946 t/h	5715 t/h	5501 t/h	5853 t/h	5616 t/h	5397 t/h	5195 t/h
	75 sec	1.25 min	5623 t/h	5415 t/h	5223 t/h	5043 t/h	5311 t/h	5115 t/h	4933 t/h	4763 t/h
70%	30 sec	0.50 min	7270 t/h	6904 t/h	6572 t/h	6271 t/h	6866 t/h	6520 t/h	6207 t/h	5923 t/h
	45 sec	0.75 min	6443 t/h	6153 t/h	5889 t/h	5646 t/h	6085 t/h	5811 t/h	5561 t/h	5332 t/h
	60 sec	1.00 min	5784 t/h	5550 t/h	5334 t/h	5134 t/h	5463 t/h	5242 t/h	5037 t/h	4849 t/h
	75 sec	1.25 min	5248 t/h	5054 t/h	4875 t/h	4707 t/h	4957 t/h	4774 t/h	4604 t/h	4445 t/h
65%	30 sec	0.50 min	6751 t/h	6410 t/h	6103 t/h	5823 t/h	6376 t/h	6054 t/h	5764 t/h	5500 t/h
	45 sec	0.75 min	5982 t/h	5714 t/h	5468 t/h	5243 t/h	5650 t/h	5396 t/h	5164 t/h	4951 t/h
	60 sec	1.00 min	5371 t/h	5154 t/h	4953 t/h	4767 t/h	5073 t/h	4867 t/h	4678 t/h	4502 t/h
	75 sec	1.25 min	4873 t/h	4693 t/h	4526 t/h	4371 t/h	4602 t/h	4433 t/h	4275 t/h	4128 t/h

MODEL: 6090 FS ● Bucket Size: 68.0 yd³ ● Number of Cycles: 4
● Material Density: 3030 lb/yd³ ● Average Loading Conditions

			100%				95%			
Fill Factor			103.0 tons				97.9 tons			
Load per Bucket			412.1 tons				391.5 tons			
Load per Truck										
Overall Mine Efficiency	Cycle Time		28 sec	30 sec	32 sec	34 sec	28 sec	30 sec	32 sec	34 sec
	Truck Spotting		0.47 min	0.50 min	0.53 min	0.57 min	0.47 min	0.50 min	0.53 min	0.57 min
83% = maximum 50 min/hour	30 sec	0.50 min	10542 tons/h	10011 tons/h	9530 tons/h	9094 tons/h	10015 tons/h	9510 tons/h	9054 tons/h	8639 tons/h
	45 sec	0.75 min	9342 tons/h	8922 tons/h	8539 tons/h	8187 tons/h	8875 tons/h	8476 tons/h	8112 tons/h	7777 tons/h
	60 sec	1.00 min	8388 tons/h	8048 tons/h	7734 tons/h	7444 tons/h	7968 tons/h	7645 tons/h	7348 tons/h	7072 tons/h
	75 sec	1.25 min	7610 tons/h	7329 tons/h	7068 tons/h	6825 tons/h	7229 tons/h	6963 tons/h	6715 tons/h	6484 tons/h
80%	30 sec	0.50 min	10161 tons/h	9649 tons/h	9186 tons/h	8765 tons/h	9653 tons/h	9166 tons/h	8726 tons/h	8327 tons/h
	45 sec	0.75 min	9004 tons/h	8600 tons/h	8230 tons/h	7891 tons/h	8554 tons/h	8170 tons/h	7819 tons/h	7496 tons/h
	60 sec	1.00 min	8084 tons/h	7757 tons/h	7455 tons/h	7175 tons/h	7680 tons/h	7369 tons/h	7082 tons/h	6817 tons/h
	75 sec	1.25 min	7335 tons/h	7064 tons/h	6813 tons/h	6579 tons/h	6968 tons/h	6711 tons/h	6472 tons/h	6250 tons/h
75%	30 sec	0.50 min	9526 tons/h	9046 tons/h	8612 tons/h	8217 tons/h	9050 tons/h	8593 tons/h	8181 tons/h	7806 tons/h
	45 sec	0.75 min	8442 tons/h	8062 tons/h	7716 tons/h	7398 tons/h	8020 tons/h	7659 tons/h	7330 tons/h	7028 tons/h
	60 sec	1.00 min	7579 tons/h	7272 tons/h	6989 tons/h	6727 tons/h	7200 tons/h	6908 tons/h	6639 tons/h	6390 tons/h
	75 sec	1.25 min	6876 tons/h	6623 tons/h	6387 tons/h	6167 tons/h	6533 tons/h	6292 tons/h	6068 tons/h	5859 tons/h
70%	30 sec	0.50 min	8891 tons/h	8443 tons/h	8037 tons/h	7669 tons/h	8446 tons/h	8020 tons/h	7636 tons/h	7286 tons/h
	45 sec	0.75 min	7879 tons/h	7525 tons/h	7201 tons/h	6905 tons/h	7485 tons/h	7149 tons/h	6841 tons/h	6559 tons/h
	60 sec	1.00 min	7074 tons/h	6787 tons/h	6523 tons/h	6278 tons/h	6720 tons/h	6448 tons/h	6197 tons/h	5964 tons/h
	75 sec	1.25 min	6418 tons/h	6181 tons/h	5961 tons/h	5756 tons/h	6097 tons/h	5872 tons/h	5663 tons/h	5469 tons/h
65%	30 sec	0.50 min	8256 tons/h	7840 tons/h	7463 tons/h	7122 tons/h	7843 tons/h	7448 tons/h	7090 tons/h	6766 tons/h
	45 sec	0.75 min	7316 tons/h	6987 tons/h	6687 tons/h	6411 tons/h	6950 tons/h	6638 tons/h	6353 tons/h	6091 tons/h
	60 sec	1.00 min	6569 tons/h	6302 tons/h	6057 tons/h	5830 tons/h	6240 tons/h	5987 tons/h	5754 tons/h	5538 tons/h
	75 sec	1.25 min	5960 tons/h	5740 tons/h	5535 tons/h	5345 tons/h	5662 tons/h	5453 tons/h	5259 tons/h	5078 tons/h

			90%				85%			
Fill Factor			92.7 tons				87.6 tons			
Load per Bucket			370.9 tons				350.3 tons			
Load per Truck										
Overall Mine Efficiency	Cycle Time		28 sec	30 sec	32 sec	34 sec	28 sec	30 sec	32 sec	34 sec
	Truck Spotting		0.47 min	0.50 min	0.53 min	0.57 min	0.47 min	0.50 min	0.53 min	0.57 min
83% = maximum 50 min/hour	30 sec	0.50 min	9488 tons/h	9009 tons/h	8577 tons/h	8184 tons/h	8961 tons/h	8509 tons/h	8101 tons/h	7730 tons/h
	45 sec	0.75 min	8408 tons/h	8030 tons/h	7685 tons/h	7368 tons/h	7941 tons/h	7584 tons/h	7258 tons/h	6959 tons/h
	60 sec	1.00 min	7549 tons/h	7243 tons/h	6961 tons/h	6700 tons/h	7129 tons/h	6841 tons/h	6574 tons/h	6328 tons/h
	75 sec	1.25 min	6849 tons/h	6596 tons/h	6361 tons/h	6143 tons/h	6468 tons/h	6230 tons/h	6008 tons/h	5802 tons/h
80%	30 sec	0.50 min	9145 tons/h	8684 tons/h	8267 tons/h	7889 tons/h	8637 tons/h	8201 tons/h	7808 tons/h	7450 tons/h
	45 sec	0.75 min	8104 tons/h	7740 tons/h	7407 tons/h	7102 tons/h	7654 tons/h	7310 tons/h	6996 tons/h	6707 tons/h
	60 sec	1.00 min	7276 tons/h	6981 tons/h	6709 tons/h	6458 tons/h	6872 tons/h	6593 tons/h	6337 tons/h	6099 tons/h
	75 sec	1.25 min	6601 tons/h	6358 tons/h	6132 tons/h	5921 tons/h	6235 tons/h	6005 tons/h	5791 tons/h	5592 tons/h
75%	30 sec	0.50 min	8573 tons/h	8141 tons/h	7750 tons/h	7396 tons/h	8097 tons/h	7689 tons/h	7320 tons/h	6985 tons/h
	45 sec	0.75 min	7598 tons/h	7256 tons/h	6944 tons/h	6658 tons/h	7175 tons/h	6853 tons/h	6558 tons/h	6288 tons/h
	60 sec	1.00 min	6821 tons/h	6545 tons/h	6290 tons/h	6054 tons/h	6442 tons/h	6181 tons/h	5940 tons/h	5718 tons/h
	75 sec	1.25 min	6189 tons/h	5960 tons/h	5748 tons/h	5551 tons/h	5845 tons/h	5629 tons/h	5429 tons/h	5242 tons/h
70%	30 sec	0.50 min	8002 tons/h	7598 tons/h	7234 tons/h	6902 tons/h	7557 tons/h	7176 tons/h	6832 tons/h	6519 tons/h
	45 sec	0.75 min	7091 tons/h	6772 tons/h	6481 tons/h	6214 tons/h	6697 tons/h	6396 tons/h	6121 tons/h	5869 tons/h
	60 sec	1.00 min	6366 tons/h	6108 tons/h	5871 tons/h	5651 tons/h	6013 tons/h	5769 tons/h	5544 tons/h	5337 tons/h
	75 sec	1.25 min	5776 tons/h	5563 tons/h	5365 tons/h	5181 tons/h	5455 tons/h	5254 tons/h	5067 tons/h	4893 tons/h
65%	30 sec	0.50 min	7430 tons/h	7056 tons/h	6717 tons/h	6409 tons/h	7017 tons/h	6664 tons/h	6344 tons/h	6053 tons/h
	45 sec	0.75 min	6585 tons/h	6289 tons/h	6018 tons/h	5770 tons/h	6219 tons/h	5939 tons/h	5684 tons/h	5450 tons/h
	60 sec	1.00 min	5912 tons/h	5672 tons/h	5451 tons/h	5247 tons/h	5583 tons/h	5357 tons/h	5148 tons/h	4955 tons/h
	75 sec	1.25 min	5364 tons/h	5166 tons/h	4982 tons/h	4811 tons/h	5066 tons/h	4879 tons/h	4705 tons/h	4543 tons/h

TELESCOPIC HANDLERS

CONTENTS

Features	17-1
Specifications	17-2
Performance Data	17-12
Shipping Dimensions	17-26
Work Tools	17-28
Compatibility	17-34

Features:

- **Intuitive control layout** enables efficient and comfortable operation.
- **Hydraulic system** enables the use of work tools requiring both intermittent and continuous auxiliary hydraulic flows.
- **Range of lift heights and load capacities** from 2500 kg (5500 lb) to 5443 kg (12,000 lb) capacity and 5.6 m (18'4") to 17.3 m (56'9") lift height.
- **Cat® Telehandlers offer extended reach** to easily enable material to be placed over onsite obstacles.
- **Three steering modes and tight turning circles** allow simplified movement onsite and therefore increased productivity.
- **Cat Telehandlers have engine options** which either meet U.S. EPA Tier 4 Final/EU Stage IV/Japan 2014 (Tier 4 Final) emission standards, Tier 4 Interim/EU Stage IIIB/Japan 2011 (Tier 4 Interim) equivalent emission standards, or Tier 3/Stage IIIA/Japan 2006 (Tier 3) equivalent emission standards.

- **Three transmissions options are available on telehandlers.** The TH255 is fitted with a hydrostatic transmission. The TL and TH range are fitted with 4 speed powershift transmissions. The high horsepower TH range is fitted with 6 speed powershift transmissions.
- **Three types of quick couplers are offered on the various telehandler models.** The TH255 is fitted with a universal skid steer loader style coupler enabling the use of many SSL work tools. The TL and TH lines of telehandlers offer hydraulic and manual style IT interface couplers which provide excellent work tool compatibility with older models of telehandlers and other products (for example Backhoe Loaders and Small Wheel Loaders).
- **Three auxiliary hydraulic options** are available: one auxiliary hydraulic service, two auxiliary hydraulic services and continuous hydraulic flow. These options allow maximum work tool utilization.
- **Daily maintenance** consists of only a walkaround inspection, all major components and service points are located at ground level, providing excellent ease of service.

MODEL	TH255C ^{1,2}		TH336C ¹		TH336C ²	
Maximum Lift Height	5.6 m	18'4"	6.1 m	20'0"	6.1 m	20'0"
Maximum Lift Capacity	2500 kg	5500 lb	3300 kg	7275 lb	3300 kg	7275 lb
Operating Weight	5010 kg	11,050 lb	6820 kg	15,035 lb	6820 kg	15,035 lb
Flywheel Power (Gross)						
Standard	55 kW	74 hp	74.5 kW	100 hp	74.5 kW	101 hp
Option 1	—	—	92.6 kW	124 hp	93.1 kW	125 hp
Option 2	—	—	106 kW	142 hp	—	—
Engine Model						
Standard	Deutz TD 2.9L L4		C3.4B Tier 4 Interim equivalent		C4.4 Tier 3 equivalent	
Option 1	—	—	C4.4 ACERT™ Tier 4 Interim equivalent		C4.4 Tier 3 equivalent	
Option 2	—	—	C4.4 ACERT Tier 4 Interim equivalent		—	
Rated Engine RPM	1800		2200		2400	
No. of Cylinders	4		4		4	
Standard Engine						
Bore	92 mm	3.6"	99 mm	3.9"	105 mm	4.13"
Stroke	110 mm	4.3"	110 mm	4.33"	127 mm	4.99"
Displacement	2.9 L	177 in ³	3.4 L	207.5 in ³	4.4 L	269 in ³
Engine Options 1 and 2						
Bore	—	—	105 mm	4.13"	105 mm	4.13"
Stroke	—	—	127 mm	4.99"	127 mm	4.99"
Displacement	—	—	4.4 L	269 in ³	4.4 L	269 in ³
Speeds Forward:			km/h	mph	km/h	mph
1st			6.7	4.2	6.7	4.2
2nd			10.0	6.2	10.0	6.2
3rd	Hydrostatic, variable	Hydrostatic, variable	12.9	8.0	12.9	8.0
4th	0-29 km/h	0-18 mph	19.4	12.1	19.4	12.1
5th			29.7	18.5	29.7	18.5
6th			40.0	24.9	40.0	24.9
Speeds Reverse:			km/h	mph	km/h	mph
1st			6.7	4.2	6.7	4.2
2nd	Hydrostatic, variable	Hydrostatic, variable	12.9	8.0	12.9	8.0
3rd	0-29 km/h	0-18 mph	29.7	18.5	29.7	18.5
Turning Circle Radius:						
Over Tires	3200 mm	126"	3750 mm	12.3'	3820 mm	12.5'
Over Forks	4305 mm	169"	4750 mm	15.6'	4900 mm	16.0'
Standard Tires	12.00 x 16.5		15.5/80-24 16PR		15.5/80-24 16PR	
Service Refill Capacity:						
Fuel Tank @ 90% Fill	91 L	24 U.S. gal	150 L	39.6 U.S. gal	150 L	39.6 U.S. gal
Hydraulic System	98 L	26 U.S. gal	90 L	23.7 U.S. gal	90 L	23.7 U.S. gal

¹ Meets Tier 4 Interim/Stage IIIB/Japan 2011 (Tier 4 Interim) equivalent emission standards.

² Meets Tier 3/Stage IIIA/Japan 2006 (Tier 3) equivalent emission standards.

MODEL	TH337C ¹		TH337C ²		TH406C ¹	
Maximum Lift Height	7.3 m	24'0"	7.3 m	24'0"	6.1 m	20'0"
Maximum Lift Capacity	3300 kg	7275 lb	3300 kg	7275 lb	3700 kg	8157 lb
Operating Weight	7045 kg	15,531 lb	7045 kg	15,531 lb	7736 kg	17,054 lb
Flywheel Power (Gross)						
Standard	74.5 kW	100 hp	74.5 kW	101 hp	74.5 kW	100 hp
Option 1	92.6 kW	124 hp	93.1 kW	125 hp	92.6 kW	124 hp
Option 2	106 kW	142 hp	—		106 kW	142 hp
Engine Model						
Standard	C3.4B Tier 4 Interim equivalent		C4.4 Tier 3 equivalent		C3.4B Tier 4 Interim equivalent	
Option 1	C4.4 ACERT Tier 4 Interim equivalent		C4.4 Tier 3 equivalent		C4.4 ACERT Tier 4 Interim equivalent	
Option 2	C4.4 ACERT Tier 4 Interim equivalent		—		C4.4 ACERT Tier 4 Interim equivalent	
Rated Engine RPM	2200		2400		2200	
No. of Cylinders	4		4		4	
Standard Engine						
Bore	99 mm	3.9"	105 mm	4.13"	99 mm	3.9"
Stroke	110 mm	4.33"	127 mm	4.99"	110 mm	4.33"
Displacement	3.4 L	207.5 in³	4.4 L	269 in³	3.4 L	207.5 in³
Engine Options 1 and 2						
Bore	105 mm	4.13"	105 mm	4.13"	105 mm	4.13"
Stroke	127 mm	4.99"	127 mm	4.99"	127 mm	4.99"
Displacement	4.4 L	269 in³	4.4 L	269 in³	4.4 L	269 in³
Speeds Forward:	km/h	mph	km/h	mph	km/h	mph
1st	6.7	4.2	6.7	4.2	6.7	4.2
2nd	10.0	6.2	10.0	6.2	10.0	6.2
3rd	12.9	8.0	12.9	8.0	12.9	8.0
4th	19.4	12.1	19.4	12.1	19.4	12.1
5th	29.7	18.5	29.7	18.5	29.7	18.5
6th	40.0	24.9	40.0	24.9	40.0	24.9
Speeds Reverse:	km/h	mph	km/h	mph	km/h	mph
1st	6.7	4.2	6.7	4.2	6.7	4.2
2nd	12.9	8.0	12.9	8.0	12.9	8.0
3rd	29.7	18.5	29.7	18.5	29.7	18.5
Turning Circle Radius:						
Over Tires	3820 mm	12.5'	3820 mm	12.5'	3750 mm	12.3'
Over Forks	4900 mm	16.0'	4900 mm	16.0'	4750 mm	15.5'
Standard Tires	15.5/80-24 16PR		15.5/80-24 16PR		15.5/80-24 16PR	
Service Refill Capacity:						
Fuel Tank @ 90% Fill	150 L	39.6 U.S. gal	150 L	39.6 U.S. gal	150 L	39.6 U.S. gal
Hydraulic System	90 L	23.7 U.S. gal	90 L	23.7 U.S. gal	90 L	23.7 U.S. gal

¹ Meets Tier 4 Interim/Stage IIIB/Japan 2011 (Tier 4 Interim) equivalent emission standards.

² Meets Tier 3/Stage IIIA/Japan 2006 (Tier 3) equivalent emission standards.

MODEL	TH406C ²		TH407C ¹		TH407C ²	
Maximum Lift Height	6.1 m	20'0"	7.3 m	24'0"	7.3 m	24'0"
Maximum Lift Capacity	3700 kg	8157 lb	3700 kg	8157 lb	3700 kg	8157 lb
Operating Weight	7736 kg	17,054 lb	7941 kg	17,506 lb	7941 kg	17,506 lb
Flywheel Power (Gross)						
Standard	74.5 kW	101 hp	74.5 kW	100 hp	74.5 kW	101 hp
Option 1	93.1 kW	125 hp	92.6 kW	124 hp	93.1 kW	125 hp
Option 2	—		106 kW	142 hp	—	
Engine Model						
Standard	C4.4 Tier 3 equivalent		C3.4B Tier 4 Interim equivalent		C4.4 Tier 3 equivalent	
Option 1	C4.4 Tier 3 equivalent		C4.4 ACERT Tier 4 Interim equivalent		C4.4 Tier 3 equivalent	
Option 2	—		C4.4 ACERT Tier 4 Interim equivalent		—	
Rated Engine RPM	2400		2200		2400	
No. of Cylinders	4		4		4	
Standard Engine						
Bore	105 mm	4.13"	99 mm	3.9"	105 mm	4.13"
Stroke	127 mm	4.99"	110 mm	4.33"	127 mm	4.99"
Displacement	4.4 L	269 in³	3.4 L	207.5 in³	4.4 L	269 in³
Engine Options 1 and 2						
Bore	105 mm	4.13"	105 mm	4.13"	105 mm	4.13"
Stroke	127 mm	4.99"	127 mm	4.99"	127 mm	4.99"
Displacement	4.4 L	269 in³	4.4 L	269 in³	4.4 L	269 in³
Speeds Forward:	km/h	mph	km/h	mph	km/h	mph
1st	6.7	4.2	6.7	4.2	6.7	4.2
2nd	10.0	6.2	10.0	6.2	10.0	6.2
3rd	12.9	8.0	12.9	8.0	12.9	8.0
4th	19.4	12.1	19.4	12.1	19.4	12.1
5th	29.7	18.5	29.7	18.5	29.7	18.5
6th	40.0	24.9	40.0	24.9	40.0	24.9
Speeds Reverse:	km/h	mph	km/h	mph	km/h	mph
1st	6.7	4.2	6.7	4.2	6.7	4.2
2nd	12.9	8.0	12.9	8.0	12.9	8.0
3rd	29.7	18.5	29.7	18.5	29.7	18.5
Turning Circle Radius:						
Over Tires	3820 mm	12.5'	3820 mm	12.5'	3820 mm	12.5'
Over Forks	4900 mm	16.0'	4900 mm	16.0'	4900 mm	16.0'
Standard Tires	15.5/80-24 16PR		15.5/80-24 16PR		15.5/80-24 16PR	
Service Refill Capacity:						
Fuel Tank @ 90% Fill	150 L	39.6 U.S. gal	150 L	39.6 U.S. gal	150 L	39.6 U.S. gal
Hydraulic System	90 L	23.7 U.S. gal	90 L	23.7 U.S. gal	90 L	23.7 U.S. gal

¹ Meets Tier 4 Interim/Stage IIIB/Japan 2011 (Tier 4 Interim) equivalent emission standards.

² Meets Tier 3/Stage IIIA/Japan 2006 (Tier 3) equivalent emission standards.

MODEL	TH414C ¹		TH414C ²		TH417C ¹	
Maximum Lift Height	13.7 m	45'0"	13.7 m	45'0"	17.3 m	56'9"
Maximum Lift Capacity	3700 kg	8157 lb	3700 kg	8157 lb	4000 kg	8818 lb
Operating Weight	9360 kg	20,635 lb	9360 kg	20,635 lb	11 800 kg	26,014 lb
Flywheel Power (Gross)						
Standard	74.5 kW	100 hp	74.5 kW	101 hp	74.5 kW	101 hp
Engine Model						
Standard	C3.4B		C4.4		C3.4B	
	Tier 4 Interim equivalent		Tier 3 equivalent		Tier 4 Interim equivalent	
Rated Engine RPM	2400		2400		2400	
No. of Cylinders	4		4		4	
Standard Engine						
Bore	99 mm	3.9 in	105 mm	4.13"	99 mm	3.9"
Stroke	110 mm	4.33 in	127 mm	4.99"	110 mm	4.33"
Displacement	3.4 L	207.5 in³	4.4 L	269 in³	3.4 L	207.5 in³
Speeds Forward:	km/h	mph	km/h	mph	km/h	mph
1st	7.0	4.3	7.0	4.3	7.0	4.3
2nd	12.0	7.4	12.0	7.4	12.0	7.4
3rd	21.0	13.0	21.0	13.0	21.0	13.0
4th	32.0	19.8	32.0	19.8	32.0	19.8
Speeds Reverse:	km/h	mph	km/h	mph	km/h	mph
1st	7.0	4.3	7.0	4.3	7.0	4.3
2nd	12.0	7.4	12.0	7.4	12.0	7.4
3rd	21.0	13.0	21.0	13.0	21.0	13.0
Turning Circle Radius:						
Over Tires	3805 mm	12.4'	3920 mm	12.8'	3920 mm	12.8'
Over Forks	5640 mm	18.5'	5650 mm	18.5'	5650 mm	18.5'
Standard Tires	14.00-24 16 PRTG-02		14.00-24 16 PRTG-02		14.00-24 16 PRTG-02	
Service Refill Capacity:						
Fuel Tank @ 90% Fill	150 L	39.6 U.S. gal	150 L	39.6 U.S. gal	150 L	39.6 U.S. gal
Hydraulic System	90 L	23.7 U.S. gal	90 L	23.7 U.S. gal	90 L	23.7 U.S. gal

¹ Meets Tier 4 Interim/Stage IIIB/Japan 2011 (Tier 4 Interim) equivalent emission standards.

² Meets Tier 3/Stage IIIA/Japan 2006 (Tier 3) equivalent emission standards.

MODEL	TH417C ²		TH514C ¹		TH514C ²	
Maximum Lift Height	17.3 m	56'9"	13.7 m	45'0"	13.7 m	45'0"
Maximum Lift Capacity	4000 kg	8818 lb	4999 kg	11,020 lb	4999 kg	11,020 lb
Operating Weight	11 800 kg	26,014 lb	10 760 kg	23,721 lb	10 760 kg	23,721 lb
Flywheel Power (Gross)						
Standard	74.5 kW	101 hp	74.5 kW	100 hp	74.5 kW	101 hp
Engine Model						
Standard	C4.4		C3.4B		C4.4	
	Tier 3 equivalent		Tier 4 Interim equivalent		Tier 3 equivalent	
Rated Engine RPM	2400		2400		2400	
No. of Cylinders	4		4		4	
Standard Engine						
Bore	105 mm	4.13"	99 mm	3.9"	105 mm	4.13"
Stroke	127 mm	4.99"	110 mm	4.33"	127 mm	4.99"
Displacement	4.4 L	269 in³	3.4 L	207.5 in³	4.4 L	269 in³
Speeds Forward:	km/h	mph	km/h	mph	km/h	mph
1st	7.0	4.3	7.0	4.3	7.0	4.3
2nd	12.0	7.4	12.0	7.4	12.0	7.4
3rd	21.0	13.0	21.0	13.0	21.0	13.0
4th	32.0	19.8	32.0	19.8	32.0	19.8
Speeds Reverse:	km/h	mph	km/h	mph	km/h	mph
1st	7.0	4.3	7.0	4.3	7.0	4.3
2nd	12.0	7.4	12.0	7.4	12.0	7.4
3rd	21.0	13.0	21.0	13.0	21.0	13.0
Turning Circle Radius:						
Over Tires	3920 mm	12.8'	3920 mm	12.8'	3920 mm	12.8'
Over Forks	5650 mm	18.5'	5570 mm	18.2'	5650 mm	18.5'
Standard Tires	14.00-24 16 PRTG-02		14.00-24 16 PRTG-02		14.00-24 16 PRTG-02	
Service Refill Capacity:						
Fuel Tank @ 90% Fill	150 L	39.6 U.S. gal	150 L	39.6 U.S. gal	150 L	39.6 U.S. gal
Hydraulic System	90 L	23.7 U.S. gal	90 L	23.7 U.S. gal	90 L	23.7 U.S. gal

¹ Meets Tier 4 Interim/Stage IIIB/Japan 2011 (Tier 4 Interim) equivalent emission standards.

² Meets Tier 3/Stage IIIA/Japan 2006 (Tier 3) equivalent emission standards.

MODEL	TL642C ¹		TL642C ²		TL943C ¹	
Maximum Lift Height	12.8 m	42'0"	12.8 m	42'0"	13.1 m	43'0"
Maximum Lift Capacity	2948 kg	6500 lb	2948 kg	6500 lb	4082 kg	9000 lb
Operating Weight	9909 kg	21,845 lb	9999 kg	22,045 lb	12 304 kg	27,125 lb
Flywheel Power (Gross)	75 kW	100.6 hp	74.5 kW	101 hp	83 kW	111.3 hp
Engine Model	C3.4B		C4.4		C3.4B	
	Tier 4 Interim equivalent		Tier 3 equivalent		Tier 4 Interim equivalent	
Rated Engine RPM	2200		2400		2200	
No. of Cylinders	4		4		4	
Bore	99 mm	3.9"	105 mm	4.13"	99 mm	3.9"
Stroke	110 mm	4.3"	127 mm	4.99"	110 mm	4.3"
Displacement	3.4 L	207.5 in³	4.4 L	269 in³	3.4 L	207.5 in³
Speeds Forward:	km/h	mph	km/h	mph	km/h	mph
1st	5.6	3.5	5.7	3.6	5.4	3.4
2nd	11.1	6.9	11.1	6.9	10.4	6.5
3rd	25.1	15.6	25.9	16.1	23.8	14.8
4th	32.9	20.5	35.4	22.0	32.6	20.3
Speeds Reverse:	km/h	mph	km/h	mph	km/h	mph
1st	5.6	3.5	5.7	3.6	5.4	3.4
2nd	11.2	7.0	11.1	6.9	10.6	6.6
3rd	25.2	15.7	26.0	16.2	23.1	14.4
Turning Circle Radius:						
Over Tires	3588 mm	11.7'	3588 mm	11.7'	3658 mm	12.0'
Over Forks	4633 mm	15.2'	4633 mm	15.2'	5197 mm	17.0'
Standard Tires	370/75-28 Duraforce MT		370/75-28 Duraforce MT		370/75-28 Duraforce MT	
Service Refill Capacity:						
Fuel Tank @ 90% Fill	144 L	38 U.S. gal	144 L	38 U.S. gal	144 L	38 U.S. gal
Hydraulic System	144 L	38 U.S. gal	144 L	38 U.S. gal	178 L	47 U.S. gal

¹ Meets Tier 4 Interim/Stage IIIB/Japan 2011 (Tier 4 Interim) equivalent emission standards.

² Meets Tier 3/Stage IIIA/Japan 2006 (Tier 3) equivalent emission standards.

MODEL	TL943C ²		TL1055C ¹		TL1055C ²	
Maximum Lift Height	13.1 m	43.0'	16.8 m	55.1'	16.8 m	55.1'
Maximum Lift Capacity	4082 kg	9000 lb	4536 kg	10,000 lb	4536 kg	10,000 lb
Operating Weight	12 304 kg	27,125 lb	15 495 kg	34,160 lb	15 468 kg	34,100 lb
Flywheel Power (Gross)	82.1 kW	110.1 hp	106 kW	142 hp	106 kW	142 hp
Engine Model	C4.4 Tier 3 equivalent		C4.4 ACERT Tier 4 Interim equivalent		C4.4 Tier 3 equivalent	
Rated Engine RPM	2400		2200		2400	
No. of Cylinders	4		4		4	
Bore	105 mm	4.13"	105 mm	4.13"	105 mm	4.13"
Stroke	127 mm	4.99"	127 mm	4.99"	127 mm	4.99"
Displacement	4.4 L	269 in³	4.4 L	269 in³	4.4 L	269 in³
Speeds Forward:	km/h	mph	km/h	mph	km/h	mph
1st	5.4	3.4	5.3	3.3	5.3	3.3
2nd	10.4	6.5	10.2	6.4	10.1	6.3
3rd	23.8	14.8	23.4	14.6	22	13.7
4th	32.6	20.3	32.8	20.4	29.4	18.3
Speeds Reverse:	km/h	mph	km/h	mph	km/h	mph
1st	5.4	3.4	5.3	3.3	5.3	3.3
2nd	10.6	6.6	10.2	6.4	10.1	6.3
3rd	23.1	14.4	23.3	14.5	20.9	13.0
Turning Circle Radius:						
Over Tires	3658 mm	12.0'	3962 mm	12.9'	3962 mm	12.9'
Over Forks	5197 mm	17.0'	4267 mm	13.9'	4267 mm	13.9'
Standard Tires	370/75-28 Duraforce MT		400/75-28 Duraforce MT		400/75-28 Duraforce MT	
Service Refill Capacity:						
Fuel Tank @ 90% Fill	144 L	38 U.S. gal	144 L	38 U.S. gal	144 L	38 U.S. gal
Hydraulic System	178 L	47 U.S. gal	238 L	63 U.S. gal	238 L	63 U.S. gal

¹ Meets Tier 4 Interim/Stage IIIB/Japan 2011 (Tier 4 Interim) equivalent emission standards.

² Meets Tier 3/Stage IIIA/Japan 2006 (Tier 3) equivalent emission standards.

MODEL	TL1255C¹		TL1255C²	
Maximum Lift Height	16.6 m	54'5"	16.6 m	54'5"
Maximum Lift Capacity	5443 kg	12,000 lb	5443 kg	12,000 lb
Operating Weight	16 267 kg	35,860 lb	16 211 kg	35,740 lb
Flywheel Power (Gross)	106 kW	142 hp	106 kW	142 hp
Engine Model	C4.4 ACERT		C4.4	
	Tier 4 Interim equivalent		Tier 3 equivalent	
Rated Engine RPM	2200		2400	
No. of Cylinders	4		4	
Bore	105 mm	4.13"	105 mm	4.13"
Stroke	127 mm	4.99"	127 mm	4.99"
Displacement	4.4 L	269 in³	4.4 L	269 in³
Speeds Forward:	km/h	mph	km/h	mph
1st	5.3	3.3	5.3	3.3
2nd	10.2	6.4	10.1	6.3
3rd	23.4	14.6	22	13.7
4th	32.8	20.4	29.4	18.3
Speeds Reverse:	km/h	mph	km/h	mph
1st	5.3	3.3	5.3	3.3
2nd	10.2	6.4	10.1	6.3
3rd	23.3	14.5	20.9	13.0
Turning Circle Radius:				
Over Tires	3962 mm	12.9'	3962 mm	12.9'
Over Forks	4267 mm	13.9'	4267 mm	13.9'
Standard Tires	400/75-28 Duraforce MT		400/75-28 Duraforce MT	
Service Refill Capacity:				
Fuel Tank @ 90% Fill	144 L	38 U.S. gal	144 L	38 U.S. gal
Hydraulic System	238 L	63 U.S. gal	238 L	63 U.S. gal

¹ Meets Tier 4 Interim/Stage IIIB/Japan 2011 (Tier 4 Interim) equivalent emission standards.

² Meets Tier 3/Stage IIIA/Japan 2006 (Tier 3) equivalent emission standards.

MODEL	TL1055D¹		TL1055D²	
Maximum Lift Height	16.7 m	54'9"	16.7 m	54'9"
Maximum Lift Capacity	4536 kg	10,000 lb	4536 kg	10,000 lb
Operating Weight	14 460 kg	31,879 lb	14 340 kg	31,614 lb
Flywheel Power (Gross)	106 kW	142 hp	106 kW	142 hp
Engine Model	C4.4 ACERT Tier 4 Interim equivalent		C4.4 ACERT Tier 4 Interim equivalent	
Rated Engine RPM	2200		2400	
No. of Cylinders	4		4	
Bore	105 mm	4.13"	105 mm	4.13"
Stroke	127 mm	4.99"	127 mm	4.99"
Displacement	4.4 L	269 in³	4.4 L	269 in³
Speeds Forward:	km/h	mph	km/h	mph
1st	5.1	3.2	5.1	3.2
2nd	10.0	6.2	10.0	6.2
3rd	22.9	14.2	22.9	14.2
4th	33.0	20.5	33.0	20.5
Speeds Reverse:	km/h	mph	km/h	mph
1st	5.1	3.2	5.1	3.2
2nd	10.0	6.2	10.0	6.2
3rd	22.9	14.2	22.9	14.2
Turning Circle Radius:				
Over Tires	4291 mm	14.0'	4291 mm	14.0'
Over Forks	5735 mm	18.0'	5735 mm	18.0'
Standard Tires	400/75-28 Air Duraforce		400/75-28 Air Duraforce	
Service Refill Capacity:				
Fuel Tank @ 90% Fill	145 L	38.3 U.S. gal	145 L	38.3 U.S. gal
Hydraulic System	184 L	48.6 U.S. gal	184 L	48.6 U.S. gal

¹ Meets Tier 4 Final/Stage IV/Japan 2014 (Tier 4 Final) emission standards.

² Meets Tier 3/Stage IIIA/Japan 2006 (Tier 3) equivalent emission standards.

MODEL	TL1255D¹		TL1255D²	
Maximum Lift Height	16.6 m	54'5"	16.6 m	54'5"
Maximum Lift Capacity	5443 kg	12,000 lb	5443 kg	12,000 lb
Operating Weight	15 586 kg	34,361 lb	15 466 kg	34,097 lb
Flywheel Power (Gross)	106 kW	142 hp	106 kW	142 hp
Engine Model	C4.4 ACERT Tier 4 Interim equivalent		C4.4 ACERT Tier 4 Interim equivalent	
Rated Engine RPM	2200		2400	
No. of Cylinders	4		4	
Bore	105 mm	4.13"	105 mm	4.13"
Stroke	127 mm	4.99"	127 mm	4.99"
Displacement	4.4 L	269 in³	4.4 L	269 in³
Speeds Forward:	km/h	mph	km/h	mph
1st	5.1	3.2	5.1	3.2
2nd	10.0	6.2	10.0	6.2
3rd	22.9	14.2	22.9	14.2
4th	33.0	20.5	33.0	20.5
Speeds Reverse:	km/h	mph	km/h	mph
1st	5.1	3.2	5.1	3.2
2nd	10.0	6.2	10.0	6.2
3rd	22.9	14.2	22.9	14.2
Turning Circle Radius:				
Over Tires	4291 mm	14.0'	4291 mm	14.0'
Over Forks	5735 mm	18.0'	5735 mm	18.0'
Standard Tires	400/75-28 Air Duraforce		400/75-28 Air Duraforce	
Service Refill Capacity:				
Fuel Tank @ 90% Fill	145 L	38.3 U.S. gal	145 L	38.3 U.S. gal
Hydraulic System	189 L	49.9 U.S. gal	189 L	49.9 U.S. gal

¹ Meets Tier 4 Final/Stage IV/Japan 2014 (Tier 4 Final) emission standards.

² Meets Tier 3/Stage IIIA/Japan 2006 (Tier 3) equivalent emission standards.

TH255C
ROW Version

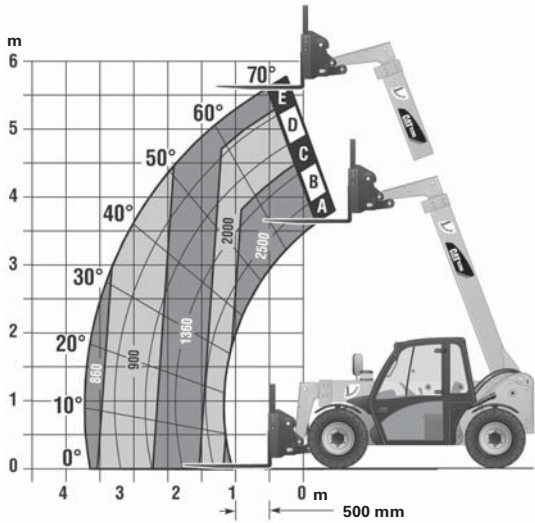

TH255C
North American Version

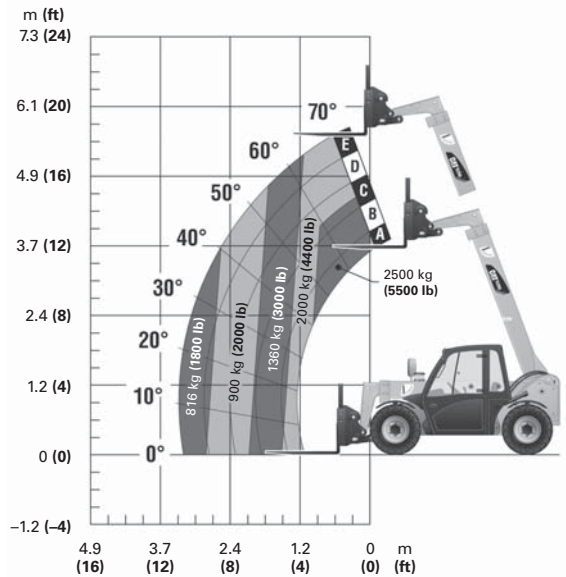

Numbers in chart measured in kilograms.

Maximum lift capacity	2500 kg	5500 lb
Maximum lift height	5.6 m	18'4"
Load at maximum height	1360 kg	2998 lb
Maximum forward reach	3.25 m	10'10"
Load at maximum reach	860 kg	1896 lb

Maximum lift capacity	2500 kg	5500 lb
Maximum lift height	5.6 m	18'4"
Load at maximum height	2000 kg	4400 lb
Maximum forward reach	3.25 m	10'10"
Load at maximum reach	816 kg	1800 lb

TH336C

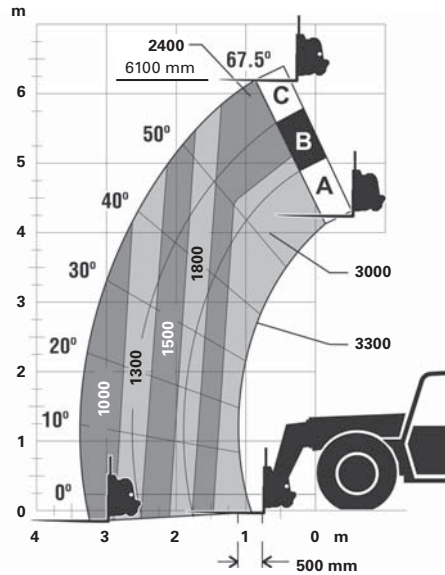

TH337C

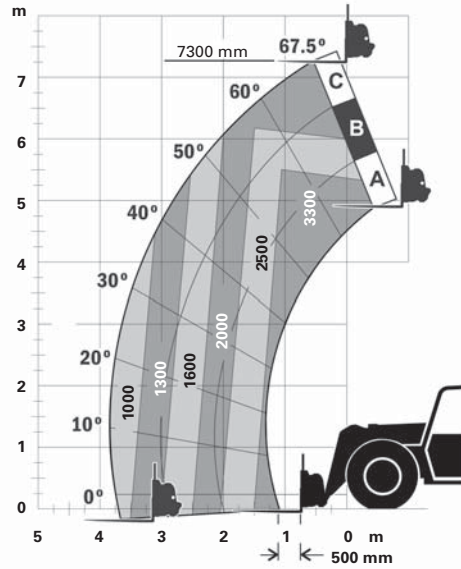

Numbers in chart measured in kilograms.

Numbers in chart measured in kilograms.

Maximum lift capacity	3300 kg	7275 lb
Maximum lift height	6.1 m	20'0"
Load at maximum height	2400 kg	5291 lb
Maximum forward reach	3.11 m	10'2"
Load at maximum reach	1000 kg	2204 lb

Maximum lift capacity	3300 kg	7275 lb
Maximum lift height	7.3 m	24'0"
Load at maximum height	2000 kg	4409 lb
Maximum forward reach	3.76 m	12'4"
Load at maximum reach	1000 kg	2204 lb

TH406C

North American Version

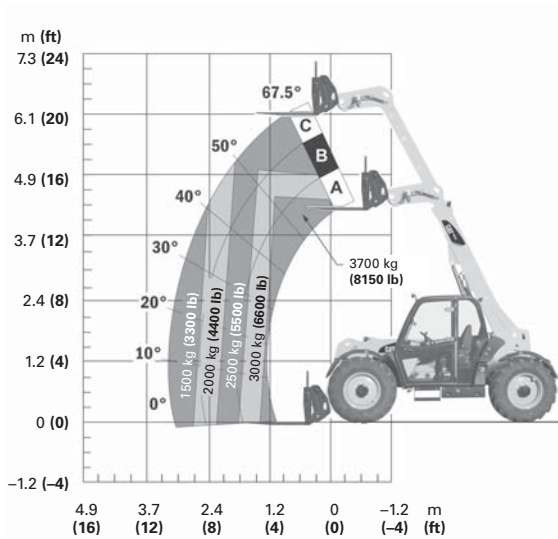

TH406C

ROW Version

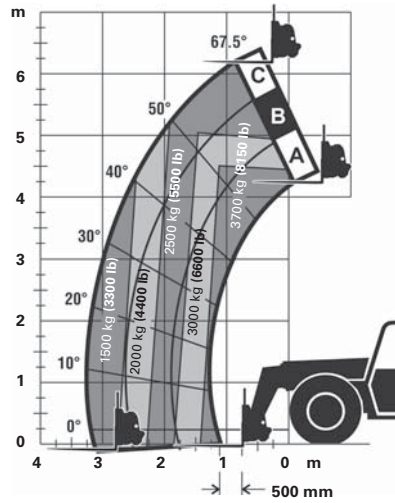

Maximum lift capacity	3700 kg	8150 lb
Maximum lift height	6.1 m	20'0"
Load at maximum height	2500 kg	5511 lb
Maximum forward reach	3.11 m	10'2"
Load at maximum reach	1500 kg	3300 lb

Maximum lift capacity	3700 kg	8150 lb
Maximum lift height	6.1 m	20'0"
Load at maximum height	2500 kg	5511 lb
Maximum forward reach	3.11 m	10'2"
Load at maximum reach	1500 kg	3300 lb

TH407C
ROW Version

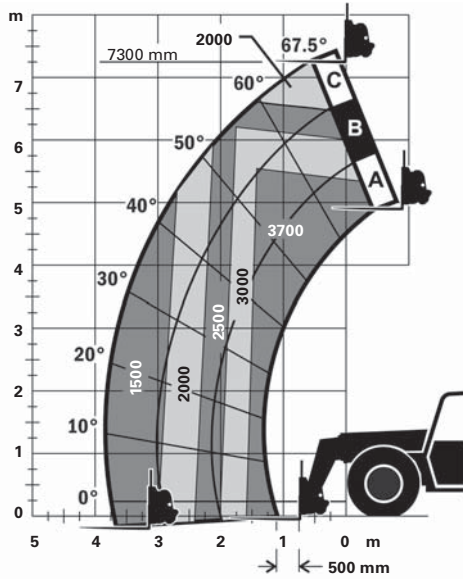

TH407C
North American Version

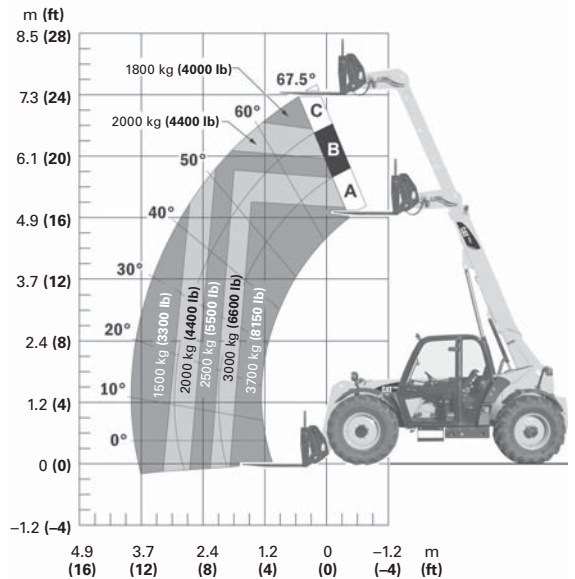

Numbers in chart measured in kilograms.

Maximum lift capacity	3700 kg	8150 lb
Maximum lift height	7.3 m	24'0"
Load at maximum height	2000 kg	4410 lb
Maximum forward reach	3.76 m	12'4"
Load at maximum reach	1500 kg	3300 lb

Maximum lift capacity	3700 kg	8150 lb
Maximum lift height	7.3 m	24'0"
Load at maximum height	1800 kg	4000 lb
Maximum forward reach	3.76 m	12'4"
Load at maximum reach	1500 kg	3300 lb

TH414C
Stabilizers Up

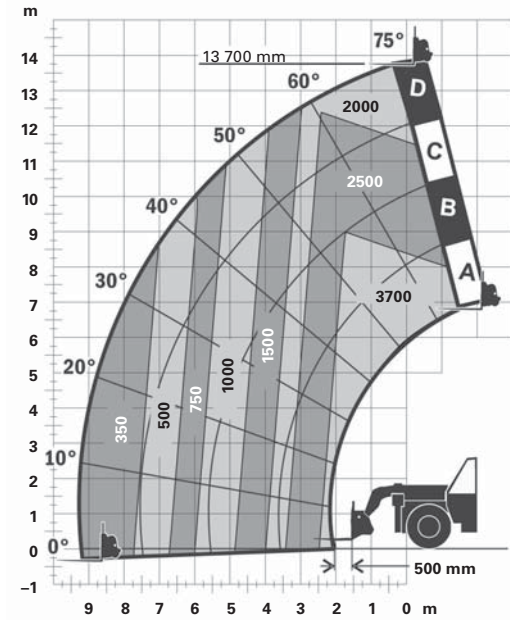

Numbers in chart measured in kilograms.

Maximum lift capacity	3700 kg	8150 lb
Maximum lift height	13.7 m	44'11"
Load at maximum height	2000 kg	4410 lb
Maximum forward reach	9.23 m	30'3"
Load at maximum reach	350 kg	771 lb

TH414C
Stabilizers Down

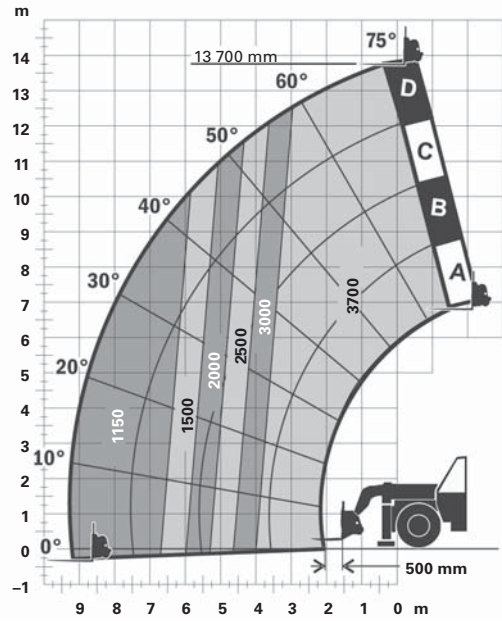

Numbers in chart measured in kilograms.

Maximum lift capacity	3700 kg	8150 lb
Maximum lift height	13.7 m	44'11"
Load at maximum height	3700 kg	8150 lb
Maximum forward reach	9.23 m	30'3"
Load at maximum reach	1150 kg	2535 lb

TH417C
Stabilizers Up

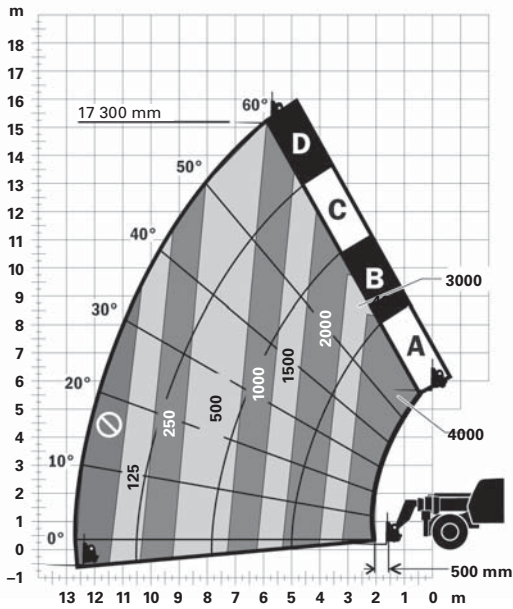

Numbers in chart measured in kilograms.

Maximum lift capacity	4000 kg	8820 lb
Maximum lift height	15.3 m	50'2"
Load at maximum height	1000 kg	2200 lb
Maximum forward reach	12.7 m	41'8"
Load at maximum reach	0 kg	0 lb

TH417C
Stabilizers Down

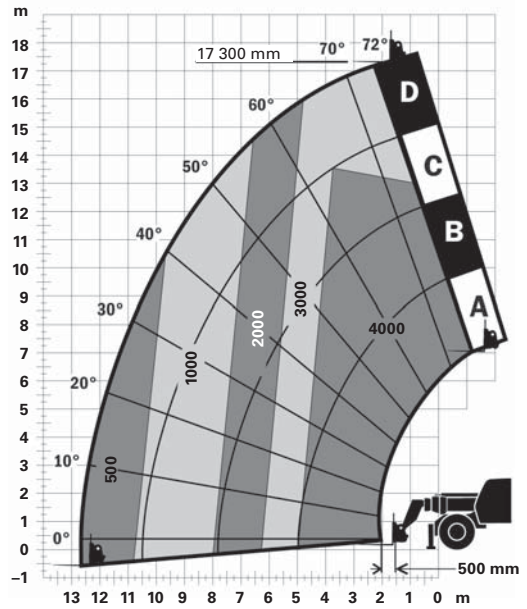

Numbers in chart measured in kilograms.

Maximum lift capacity	4000 kg	8820 lb
Maximum lift height	17.3 m	56'10"
Load at maximum height	3000 kg	6610 lb
Maximum forward reach	12.7 m	41'8"
Load at maximum reach	500 kg	1100 lb

TH514C
Stabilizers Up

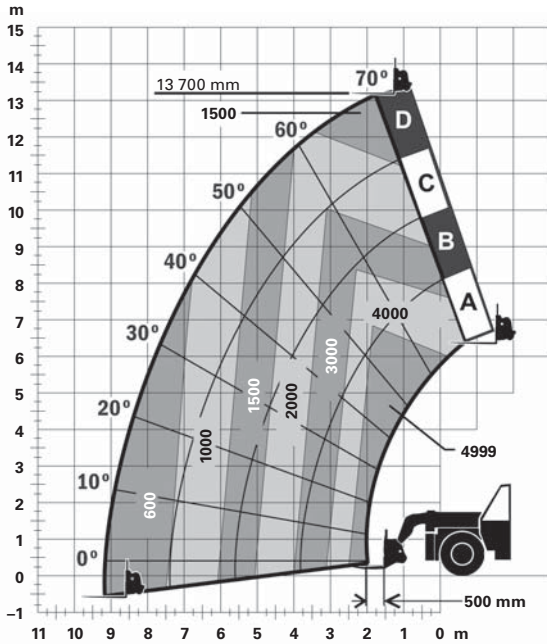

Numbers in chart measured in kilograms.

Maximum lift capacity	4999 kg	11,020 lb
Maximum lift height	13.4 m	44'0"
Load at maximum height	1500 kg	3306 lb
Maximum forward reach	9.22 m	30'3"
Load at maximum reach	600 kg	1322 lb

TH514C
Stabilizers Down

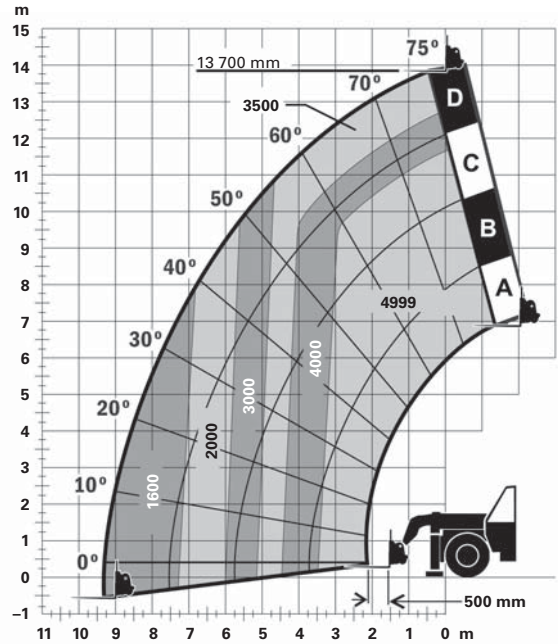

Numbers in chart measured in kilograms.

Maximum lift capacity	4999 kg	11,020 lb
Maximum lift height	13.7 m	44'11"
Load at maximum height	3500 kg	7716 lb
Maximum forward reach	9.22 m	30'3"
Load at maximum reach	1600 kg	3527 lb

TL642C
No Stabilizers

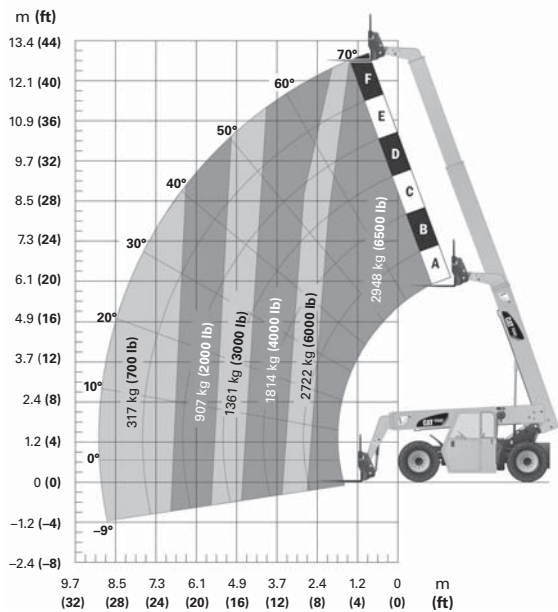

TL642C
Stabilizers Up

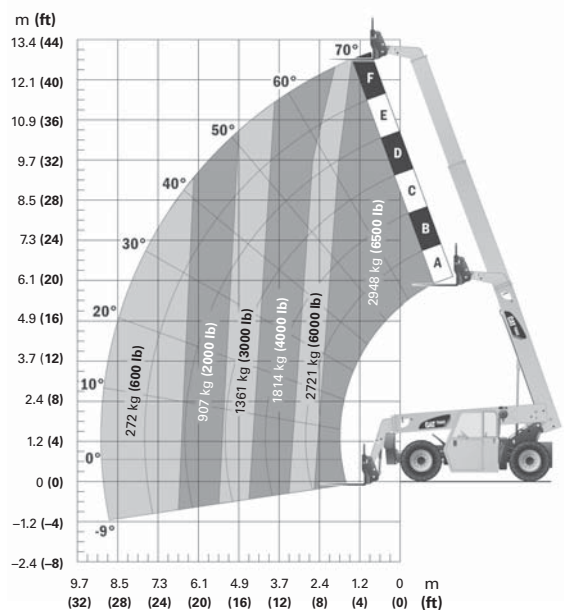

Maximum lift capacity	2948 kg	6500 lb
Maximum lift height	12.8 m	42'0"
Load at maximum height	2948 kg	6500 lb
Maximum forward reach	9.1 m	30'0"
Load at maximum reach	317 kg	700 lb

Maximum lift capacity	2948 kg	6500 lb
Maximum lift height	12.8 m	42'0"
Load at maximum height	2948 kg	6500 lb
Maximum forward reach	9.1 m	30'0"
Load at maximum reach	272 kg	600 lb

TL642C

Stabilizers Down

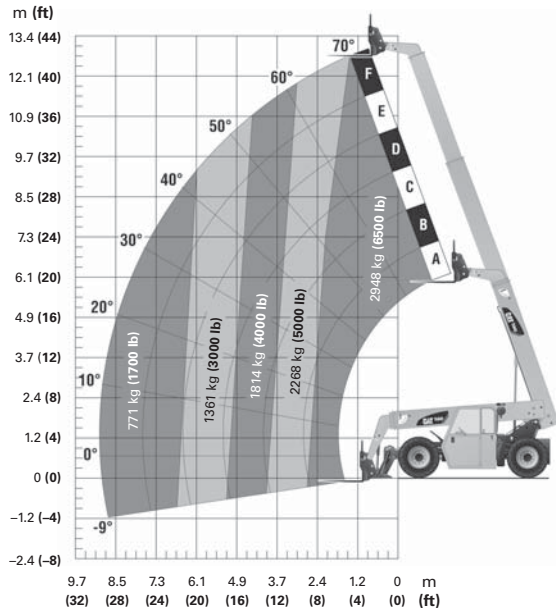

TL943C

No Stabilizers

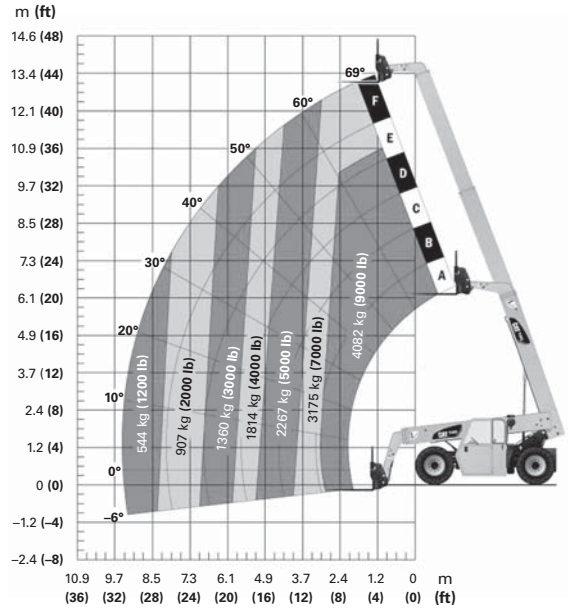

Maximum lift capacity	2948 kg	6500 lb
Maximum lift height	12.8 m	42'0"
Load at maximum height	2948 kg	6500 lb
Maximum forward reach	9.1 m	30'0"
Load at maximum reach	771 kg	1700 lb

Maximum lift capacity	4082 kg	9000 lb
Maximum lift height	13.1 m	43'0"
Load at maximum height	3175 kg	7000 lb
Maximum forward reach	9.6 m	31'5"
Load at maximum reach	544 kg	1200 lb

TL943C
Stabilizers Up

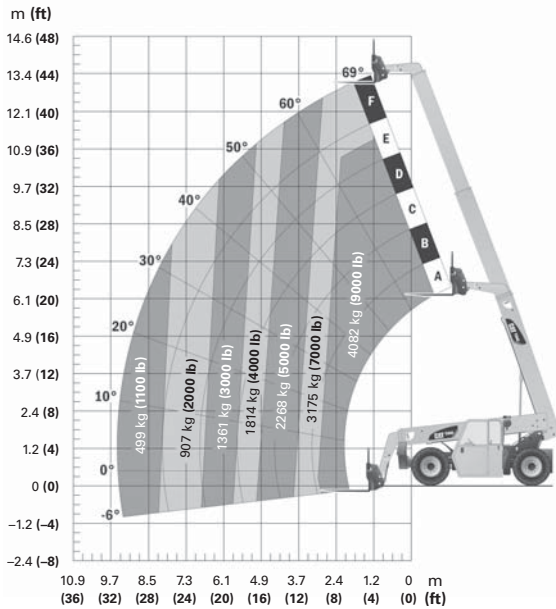

TL943C
Stabilizers Down

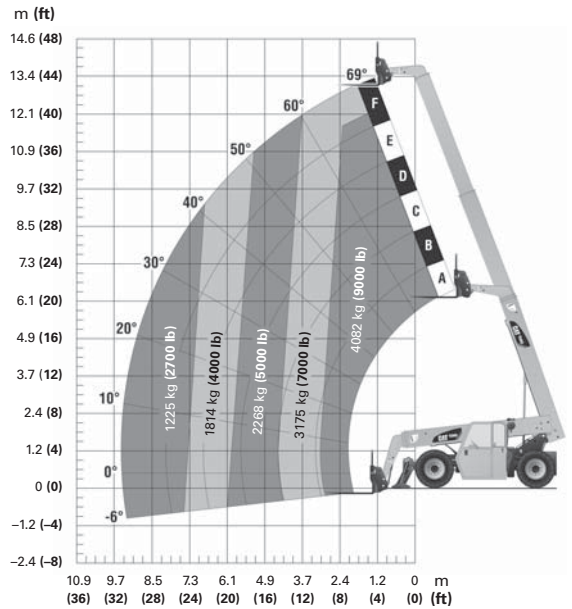

Maximum lift capacity	4082 kg	9000 lb
Maximum lift height	13.1 m	43'0"
Load at maximum height	3175 kg	7000 lb
Maximum forward reach	9.6 m	31'5"
Load at maximum reach	499 kg	1100 lb

Maximum lift capacity	4082 kg	9000 lb
Maximum lift height	13.1 m	43'0"
Load at maximum height	3175 kg	7000 lb
Maximum forward reach	9.6 m	31'5"
Load at maximum reach	1225 kg	2700 lb

TL1055C
Stabilizers Up

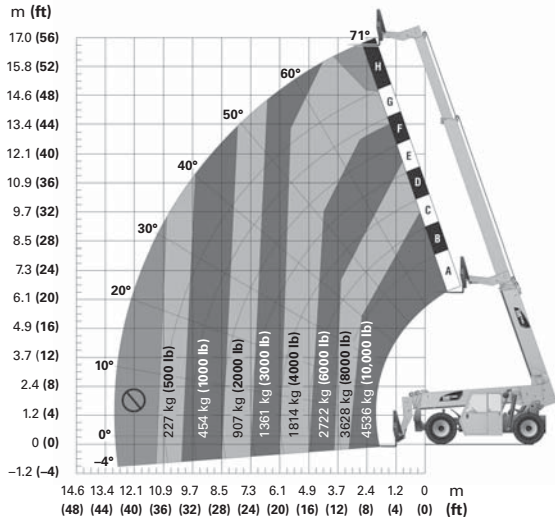

TL1055C
Stabilizers Down

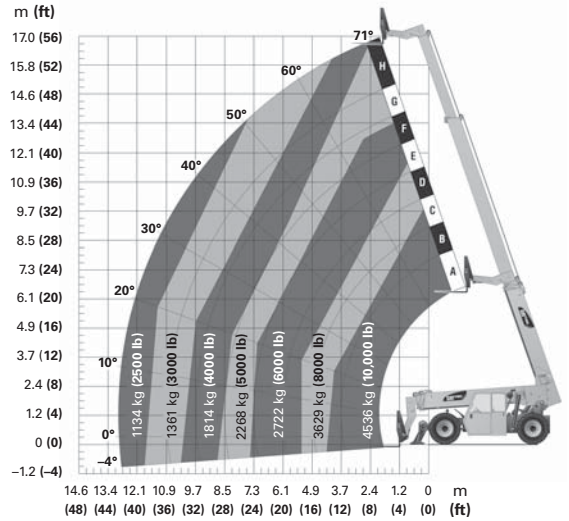

Maximum lift capacity	4536 kg	10,000 lb
Maximum lift height	16.8 m	55'0"
Load at maximum height	0 kg	0 lb
Maximum forward reach	13.0 m	42'6"
Load at maximum reach	0 kg	0 lb

Maximum lift capacity	4536 kg	10,000 lb
Maximum lift height	16.8 m	55'1"
Load at maximum height	2268 kg	5000 lb
Maximum forward reach	13.0 m	42'6"
Load at maximum reach	1134 kg	2500 lb

TL1255C
Stabilizers Up

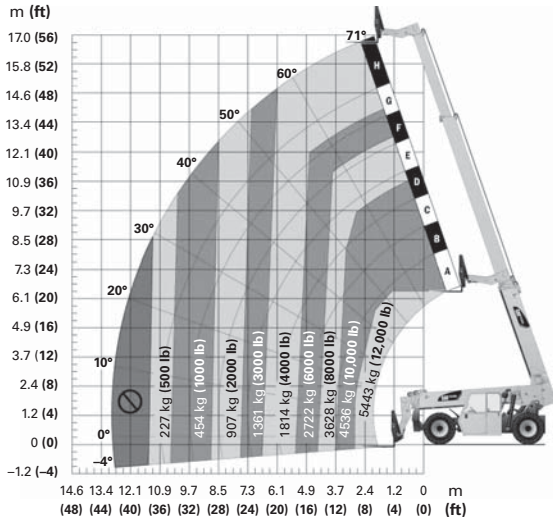

TL1255C
Stabilizers Down

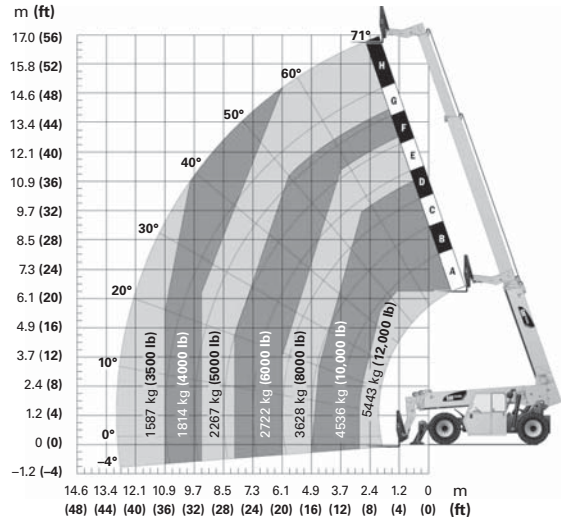

Maximum lift capacity	5443 kg	12,000 lb
Maximum lift height	16.6 m	54'5"
Load at maximum height	1814 kg	4000 lb
Maximum forward reach	13.0 m	42'6"
Load at maximum reach	0 kg	0 lb

Maximum lift capacity	5443 kg	12,000 lb
Maximum lift height	16.6 m	54'5"
Load at maximum height	2267 kg	5000 lb
Maximum forward reach	13.0 m	42'6"
Load at maximum reach	1588 kg	3500 lb

TL1055D
Stabilizers Up

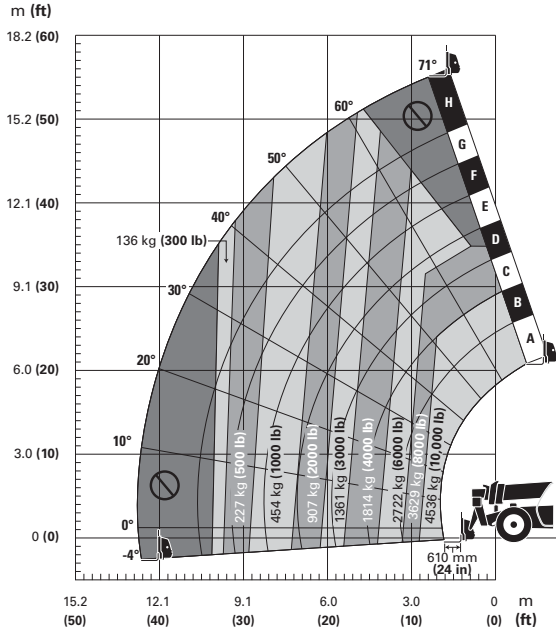

TL1055D
Stabilizers Down

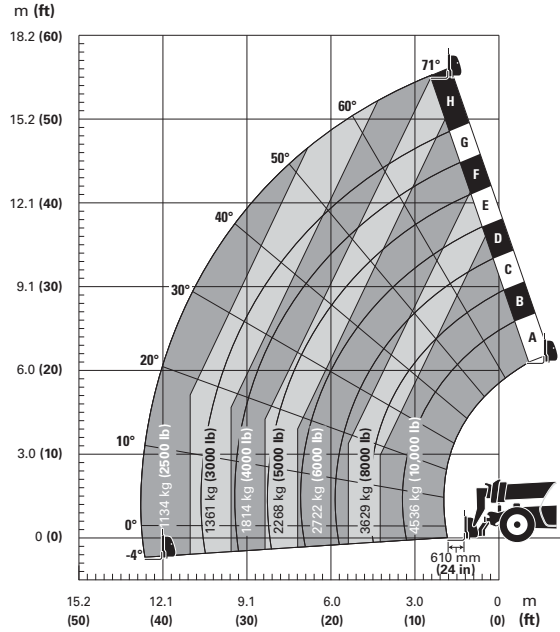

Maximum lift capacity	4536 kg	10,000 lb
Maximum lift height	16.8 m	55'0"
Load at maximum height	0 kg	0 lb
Maximum forward reach	13.0 m	42'6"
Load at maximum reach	0 kg	0 lb

Maximum lift capacity	4536 kg	10,000 lb
Maximum lift height	16.8 m	55'1"
Load at maximum height	2268 kg	5000 lb
Maximum forward reach	13.0 m	42'6"
Load at maximum reach	1134 kg	2500 lb

TL1255D
Stabilizers Up

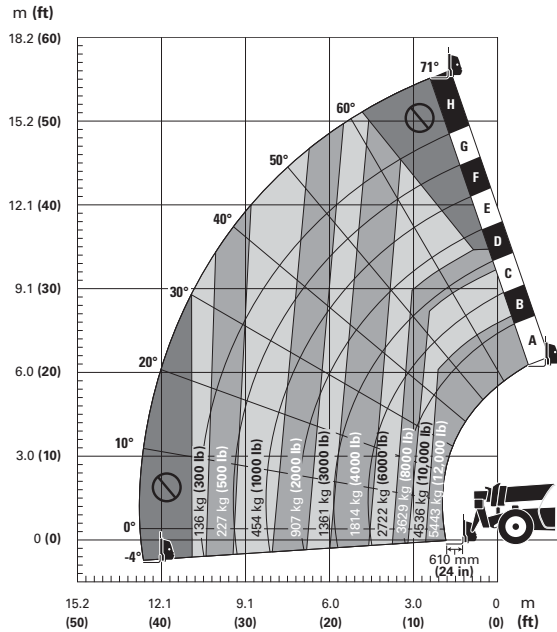

TL1255D
Stabilizers Down

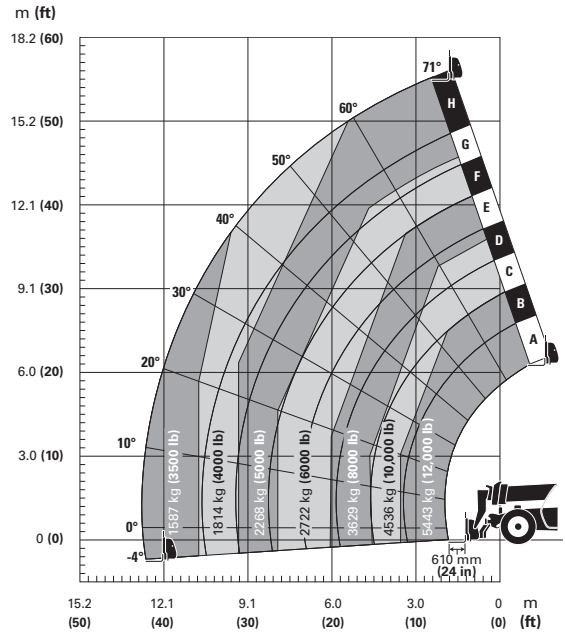

Maximum lift capacity	5443 kg	12,000 lb
Maximum lift height	16.6 m	54'5"
Load at maximum height	1814 kg	4000 lb
Maximum forward reach	13.0 m	42'6"
Load at maximum reach	0 kg	0 lb

Maximum lift capacity	5443 kg	12,000 lb
Maximum lift height	16.6 m	54'5"
Load at maximum height	2268 kg	5000 lb
Maximum forward reach	13.0 m	42'6"
Load at maximum reach	1588 kg	3500 lb

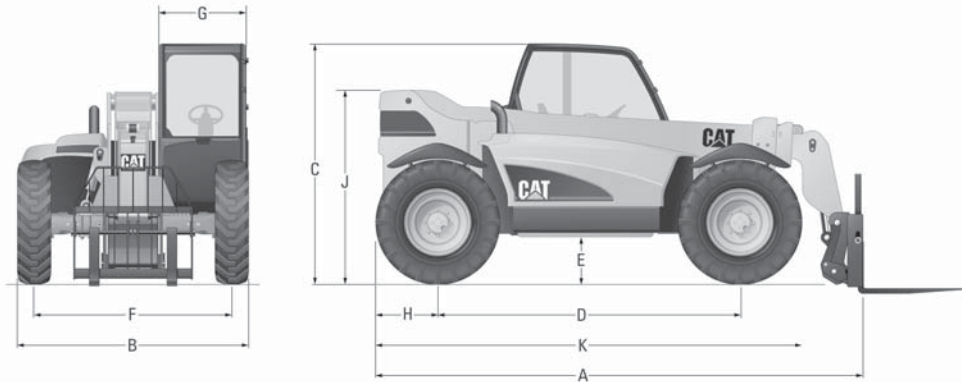

Dimensions (approx.)

Model	TH255C		TH336C		TH337C		TH406C	
	mm	ft	mm	ft	mm	ft	mm	ft
A) Length to fork face	3800	12'5"	4850	15'11"	5128	16'9"	4850	15'11"
B) Width	1800	5'10"	2382	7'10"	2382	7'10"	2382	7'10"
C) Height	1900	6'2"	2339	7'8"	2385	7'9"	2339	7'8"
D) Wheel base	2300	7'6"	2975	9'9"	3075	10'1"	2975	9'9"
E) Ground clearance	270	10"	409	1'4"	430	1'5"	409	1'4"
F) Wheel track	—		1988	6'6"	1988	6'6"	1988	6'6"
G) Cab width (inside)								
Standard	864	2'10"	880	2'11"	880	2'11"	880	2'11"
Agriculture	N/A		920	3'0"	920	3'0"	920	3'0"

Model	TH407C		TH414C		TH417C		TH514C	
	mm	ft	mm	ft	mm	ft	mm	ft
A) Length to fork face	5347	17'6"	6575	21'4"	6782	22'3"	6617	21'8"
B) Width	2382	7'10"	2430	7'11"	2440	8'0"	2440	8'0"
C) Height	2374	7'9"	2588	8'6"	2805	9'2"	2610	8'7"
D) Wheel base	3075	10'1"	3200	10'6"	3200	10'6"	3200	10'6"
E) Ground clearance	430	1'5"	407	1'4"	386	1'3"	430	1'5"
F) Wheel track	1988	6'6"	2036	6'8"	2078	6'10"	2078	6'10"
G) Cab width (inside)								
Standard	880	2'11"	880	2'11"	880	2'11"	880	2'11"
Agriculture	920	3'0"	N/A		N/A		N/A	

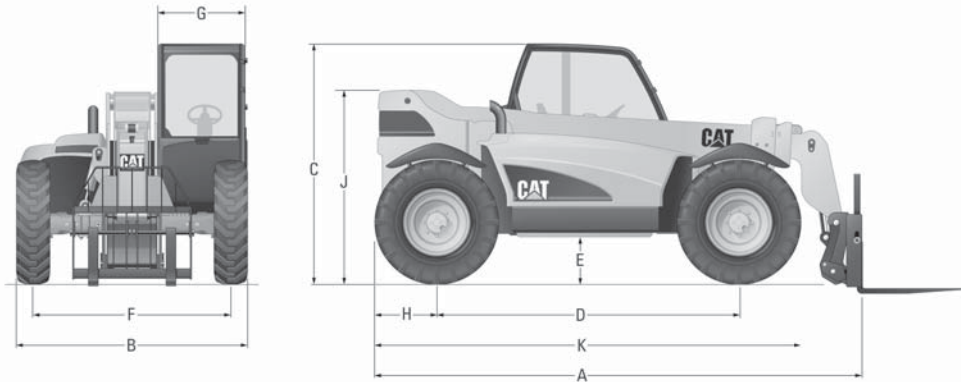
**Dimensions (approx.)**

Model	TL642C		TL943C		TL1055C		TL1255C	
	mm	ft	mm	ft	mm	ft	mm	ft
A) Length to fork face	5629	18'5"	6248	20'5"	6325	20'8"	6325	20'8"
B) Width	2426	8'0"	2426	8'0"	2565	8'4"	2565	8'4"
C) Height	2388	7'8"	2426	8'0"	2565	8'4"	2565	8'4"
D) Wheel base	3251	10'7"	3353	11'0"	3658	12'0"	3658	12'0"
E) Ground clearance	417	1'4"	483	1'7"	457	1'6"	483	1'7"
F) Wheel track	2108	6'9"	2108	6'9"	2159	7'1"	2159	7'1"
G) Cab width (inside)	940	3'1"	940	3'1"	940	3'1"	940	3'1"

Model	TL1055D		TL1255D	
	mm	ft	mm	ft
A) Length to fork face	6372	20'9"	6372	20'9"
B) Width	2559	8'4"	2559	8'4"
C) Height	2540	8'3"	2540	8'3"
D) Wheel base	3493	11'5"	3493	11'5"
E) Ground clearance	457	1'5"	457	1'5"
F) Wheel track	2140	7'0"	2140	7'0"
G) Cab width (inside)	900	3'0"	900	3'0"

All carriages are bar type with load backrest to support bulky loads.
Widespread carriages provide added stability for lifting larger loads.
Standard and widespread carriages are also available in rotating mode.

Carriage Type

Model	Standard		Standard — Framers		Rotate	Rotate — Framers		Side Shift		
TH255										
Weight w/1220 mm (48") forks	261 kg	575 lb	367 kg	810 lb	—	—	—	—	—	
Width	1219 mm	4'0"	1219 mm	4'0"	1219 mm	4'0"	—	—	—	
Height	1118 mm	3'7"	1118 mm	3'7"	1168 mm	3'10"	—	—	—	
Max. fork spread	1067 mm	3'5"	1092 mm	3'6"	1067 mm	3'5"	—	—	—	
Floating fork movement	76 mm	3"	76 mm	3"	76 mm	3"	—	—	—	
TH336 through TH417										
Weight w/1220 mm (48") forks	272 kg	600 lb	336 kg	740 kg	408 kg	900 lb	492 kg	1084 lb	422 kg	930 lb
Width	1224 mm	4'0"	1880 mm	6'2"	1224 mm	4'0"	1880 mm	6'2"	1230 mm	4'0"
Height	1039 mm	3'5"	1039 mm	3'5"	1216 mm	4'0"	1216 mm	4'0"	1135 mm	3'8"
Max. fork spread	1200 mm	3'11"	1856 mm	6'1"	1200 mm	3'11"	1856 mm	6'1"	1200 mm	3'11"
Floating fork movement	70 mm	3"	70 mm	3"	70 mm	3"	70 mm	3"	70 mm	3"
Rotation	—	—	—	—	11.5°	11.5°	—	—	—	
TH514										
Weight w/1220 mm (48") forks	303 kg	600 lb	336 kg	740 lb	408 kg	900 lb	492 kg	1084 lb	422 kg	930 lb
Width	1224 mm	4'0"	1880 mm	6'2"	1224 mm	4'0"	1880 mm	6'2"	1230 mm	4'0"
Height	1039 mm	3'5"	1039 mm	3'5"	1216 mm	4'0"	1216 mm	4'0"	1135 mm	3'8"
Max. fork spread	1200 mm	3'11"	1856 mm	6'1"	1200 mm	3'11"	1856 mm	6'1"	1200 mm	3'11"
Floating fork movement	70 mm	3"	70 mm	3"	70 mm	3"	70 mm	3"	70 mm	3"
Rotation	—	—	—	—	11.5°	11.5°	—	—	—	

Model	Carriage Type					
	Standard		Standard — Framers		Rotate 1270 mm (50")	
TL642C, TL943C, TL1055C, TL1255C						
Weight* w/1220 mm (48") forks (51 mm × 51 mm/2" × 2")	295 kg	650 lb	363 kg	800 lb	454 kg	1000 lb
Width**	1422 mm	56"	1981 mm	78"	1422 mm	56"
Height**	1270 mm	50"	1067 mm	42"	1270 mm	50"
Max. fork spread (out to out)	1270 mm	50"	1829 mm	72"	1270 mm	50"
Floating fork movement	98 mm	3.9"	98 mm	3.9"	98 mm	3.9"
Rotation	—		—		±10°	

*Weights are for information purposes only. Refer to applicable load charts for specific data.

**Dimensions are approximate.

Model	Carriage Type					
	Rotate — Framers 1830 mm (72")		Side Shift ±102 mm (±4")		Swing	
TL642C, TL943C, TL1055C, TL1255C, TL1055D, TL1255D						
Weight* w/1220 mm (48") forks (51 mm × 51 mm/2" × 2")	522 kg	1150 lb	363 kg	800 lb	975 kg	2150 lb
Width**	1981 mm	78"	1245 mm	49"	1772 mm	69.75"
Height**	1067 mm	42"	1041 mm	41"	1194 mm	47"
Max. fork spread (out to out)	1829 mm	72"	1162 mm	45.75"	1854 mm	73"
Floating fork movement	98 mm	3.9"	51 mm	2"	76 mm	3"
Rotation	±10°		—		100°	

*Weights are for information purposes only. Refer to applicable load charts for specific data.

**Dimensions are approximate.

All carriages are bar type with load backrest to support bulky loads.
Widespread carriages provide added stability for lifting larger loads.
Standard and widespread carriages are also available in rotating mode.

Non-U.S. Models

Fork Type

Pallet

Model	Forks/Sets	Size	
TH255C, TH336C, TH337C, TH406C, TH407C, TH414C, TH417C	2	45 mm × 100 mm × 1070 mm	1.77" × 4" × 42"
TH255C, TH406C, TH407C, TH514C	2	50 mm × 100 mm × 1220 mm	2" × 4" × 48"
TH406C, TH407C, TH514C	2	50 mm × 125 mm × 1220 mm	2" × 5" × 48"
TH255C, TH336C, TH337C, TH406C, TH407C, TH414C, TH417C	2	50 mm × 100 mm × 1525 mm	2" × 4" × 60"
TH255C, TH336C, TH337C, TH406C, TH407C, TH414C, TH417C, TH514C	2	50 mm × 100 mm × 1200 mm	2" × 4" × 47"
TH255C, TH336C, TH337C, TH406C, TH407C, TH414C, TH417C, TH514C, TL642C, TL943C, TL1055C, TL1055D	2	60 mm × 100 mm × 1220 mm	2.36" × 4" × 48"
TL642C, TL943C, TL1055C, TL1055D, TL1255C, TL1255D	2	60 mm × 125 mm × 1220 mm	2.36" × 5" × 48"
TH406C, TH407C, TH514C, TL642C, TL943C, TL1055C, TL1255C, TL1055D, TL1255D	2	60 mm × 150 mm × 1525 mm	2.36" × 6" × 60"

Block

Model	Forks/Sets	Size	
TH255C, TH336C, TH337C, TH406C, TH407C, TH414C, TH417C, TH514C, TL642C, TL943C, TL1055C, TL1255C, TL1055D, TL1255D	2	50 mm × 50 mm × 1220 mm	2" × 2" × 48"

Lumber

Model	Forks/Sets	Size	
TH255C	2	40 mm × 150 mm × 1525 mm	1.5" × 6" × 60"
TH406C, TH407C, TH514C, TL642C, TL943C, TL1055C, TL1055D	2	45 mm × 180 mm × 1525 mm	1.75" × 7" × 60"
TH514C, TL642C, TL943C, TL1055C, TL1055D	2	50 mm × 150 mm × 1829 mm	2" × 6" × 72"
TH406C, TH407C, TL642C, TL943C, TL1055C, TL1255C, TL1055D, TL1255D	2	60 mm × 150 mm × 1525 mm	2.36" × 6" × 60"

North American Models

Fork Type

Pallet

Model	Forks/Sets	Size
TH406C, TH407C	2	45 mm × 100 mm × 1067 mm 1.77" × 4" × 42"
TH406C, TH407C	2	50 mm × 100 mm × 1525 mm 2" × 4" × 48"
TH406C, TH407C	2	50 mm × 120 mm × 1200 mm 2" × 5" × 48"
TH406C, TH407C	2	50 mm × 125 mm × 1220 mm 2" × 6" × 60"
TH255C, TH406C, TH407C, TH514C	2	50 mm × 100 mm × 1220 mm 2" × 4" × 48"
TH406C, TH407C, TH514C, TL642C, TL943C, TL1055C, TL1055D	2	60 mm × 100 mm × 1220 mm 2.36" × 4" × 48"
TL642C, TL943C, TL1055C, TL1255C, TL1055D, TL1255D	2	60 mm × 125 mm × 1220 mm 2.36" × 5" × 48"
TH406C, TH407C, TH514C, TL642C, TL943C, TL1055C, TL1255C, TL1055D, TL1255D	2	60 mm × 150 mm × 1525 mm 2.36" × 6" × 60"

Block

Model	Forks/Sets	Size
TH255C, TH406C, TH407C, TH514C, TL642C, TL943C, TL1055C, TL1255C, TL1055D, TL1255D	2	50 mm × 50 mm × 1220 mm 2" × 2" × 48"

Lumber

Model	Forks/Sets	Size
TH255C	2	40 mm × 150 mm × 1525 mm 1.5" × 6" × 60"
TH406C, TH407C, TL642C, TL943C, TL1055C, TL1055D	2	45 mm × 180 mm × 1525 mm 1.75" × 7" × 60"
TH406C, TH407C, TH514C, TL642C, TL943C, TL1055C, TL1255C, TL1055D, TL1255D	2	50 mm × 150 mm × 1829 mm 2" × 6" × 72"
TH406C, TH407C, TL642C, TL943C, TL1055C, TL1255C, TL1055D, TL1255D	2	60 mm × 150 mm × 1525 mm 2.36" × 6" × 60"

Work Tools

Truss Boom			General Purpose Buckets		
Capacity	500 kg	1100 lb	0.75 m³ (0.98 yd³)	Capacity	0.75 m ³ 0.98 yd³
Width	850 mm	34 in	Capacity	1880 mm	74"
Length	4 m	13'1"	Weight	393 kg	867 lb
Lifting Hook, Fork Mounted			0.76 m³ (1.0 yd³)	Capacity	0.76 m ³ 1.0 yd³
Capacity	5443 kg	12,000 lb	Width	1854 mm	73"
Width	1168 mm	46"	Weight	322 kg	710 lb
Weight	159 kg	350 lb	1.0 m³ (1.3 yd³)	Capacity	1.0 m ³ 1.3 yd³
Length	800 mm	31.5"	Width	2418 mm	95"
Lifting Hook, IT			Weight	457 kg	1007 lb
Capacity	4536 kg	10,000 lb	1.3 m³ (1.75 yd³)	Capacity	1.3 m ³ 1.75 yd³
Width	697 mm	28"	Width	2445 mm	96"
Weight	98 kg	216 lb	Weight	509 kg	1122 lb
Length	500 mm	20"	Capacity	509 kg	1122 lb
Manure Fork + Grab			Grapple Bucket		
Capacity	1.8 m ³	2.34 yd³	0.76 m³ (1.0 yd³)	Capacity	0.76 m ³ 1.0 yd³
Width	2290 mm	90"	Width	1854 mm	73"
Weight	560 kg	1234 lb	Weight	497 kg	1096 lb
Tine length	1060 mm	42"	Light Material Buckets		
No. of tines		9	1.3 m³ (1.7 yd³)	Capacity	1.3 m ³ 1.7 yd³
Material Handling Arm			Width	1829 mm	72"
2135 mm (84")			Weight	348 kg	768 lb
Length	2135 mm	84"	2.0 m³ (2.6 yd³)	Capacity	2.0 m ³ 2.6 yd³
Weight	127 kg	280 lb	Width	2500 mm	98"
4162 mm (164")			Weight	457 kg	1007 lb
Length	4162 mm	164"	2.5 m³ (3.25 yd³)	Capacity	2.5 m ³ 3.25 yd³
Weight	449 kg	990 lb	Width	2500 mm	98"
Winch			Weight	526 kg	1159 lb
1360 kg (3000 lb)			3.0 m³ (3.9 yd³)	Capacity	3.0 m ³ 3.9 yd³
Capacity	1360 kg	3000 lb	Width	2700 mm	106"
Width	23 m	75 ft	Weight	599 kg	1320 lb
2722 kg (6000 lb)			Work Platform, Fork Mounted		
Capacity	2722 kg	6000 lb	1219 mm (48")	Capacity	970 kg 2000 lb
Width	46 m	150 ft	Capacity	1219 mm	48"
Work Platform, Fork Mounted			Height	2438 mm	96"
1219 mm (48")			2438 mm (96")	Capacity	970 kg 2000 lb
Capacity	970 kg	2000 lb	Capacity	970 kg	2000 lb
Width	1219 mm	48"	Width	2438 mm	96"
Height	2438 mm	96"	Height	1219 mm	48"
2438 mm (96")					
Capacity	970 kg	2000 lb			
Width	2438 mm	96"			
Height	1219 mm	48"			

Work Tools

Material Handling Bucket		
1.5 m³ (1.96 yd³)		
Capacity	1.5 m ³	1.96 yd³
Width	2418 mm	95"
Weight	480 kg	1058 lb
Multi-Grapple Bucket		
0.85 m³ (1.11 yd³)		
Capacity	0.85 m ³	1.11 yd³
Width	1854 mm	73"
Weight	630 kg	1389 lb

Multi-Purpose Buckets		
0.37 m³ (0.48 yd³)		
Capacity	0.37 m ³	0.48 yd³
Width	1829 mm	72"
Weight	410 kg	905 lb
1.0 m³ (1.3 yd³)		
Capacity	1.0 m ³	1.3 yd³
Width	2418 mm	95"
Weight	765 kg	1687 lb

Telescopic Handlers

Compatibility ● Non-U.S. Models

	TH255C	TH336C	TH337C	TH406C	TH407C	TH414C	TH417C	TH514C	TL642C	TL943C	TL1055C	TL1255C	TL1055D	TL1255D
Lifting Hook, Fork Mounted 321-0556	N/A	N/A	N/A	N/A	N/A	N/A	N/A	N/A	Yes	Yes	Yes	Yes	Yes	Yes
Lifting Hook, IT 169-6460	N/A	Yes	Yes	Yes	Yes	Yes	Yes	Yes	Yes	Yes	Yes	Yes	Yes	Yes
Manure Fork + Grab 2286 mm (90") 186-6054	N/A	Yes	Yes	Yes	Yes	N/A	N/A	N/A	N/A	N/A	N/A	N/A	N/A	N/A
Material Handling Arm 229-9714/216-8756	N/A	Yes	Yes	Yes	Yes	Yes	Yes	Yes	Yes	Yes	Yes	Yes	Yes	Yes
Truss Boom 169-3945	N/A	Yes	Yes	Yes	Yes	Yes	Yes	Yes	Yes	Yes	Yes	Yes	Yes	Yes
Work Platform, Fork Mounted 343-9739/9738	N/A	N/A	N/A	N/A	N/A	N/A	N/A	N/A	Yes	Yes	Yes	Yes	Yes	Yes
Standard Tilt Carriage 1220 mm (48") 350-9099/326-2013/2014	Yes	Yes	Yes	Yes	Yes	Yes	Yes	Yes	N/A	N/A	N/A	N/A	N/A	N/A
Standard Tilt Carriage 1270 mm (50") 301-9757	N/A	N/A	N/A	N/A	N/A	N/A	N/A	N/A	Yes	Yes	Yes	Yes	Yes	Yes
Standard Rotate/Tilt Carriage 1220 mm (48") 331-3251/231-3229	N/A	Yes	Yes	Yes	Yes	Yes	Yes	Yes	N/A	N/A	N/A	N/A	N/A	N/A
Standard Rotate/Tilt Carriage 1270 mm (50") 309-4315	N/A	N/A	N/A	N/A	N/A	N/A	N/A	N/A	Yes	Yes	Yes	Yes	Yes	Yes
Sideshift Carriage 1220 mm (48") 314-8479/222-6210/331-3252	N/A	Yes	Yes	Yes	Yes	Yes	Yes	Yes	Yes	Yes	Yes	Yes	Yes	Yes
Swing Carriage, 100°, 1829 mm (72") 318-9222	N/A	N/A	N/A	N/A	N/A	N/A	N/A	N/A	Yes	Yes	Yes	Yes	Yes	Yes
Swing Carriage, 180°, 1829 mm (72") 341-3591	N/A	N/A	N/A	N/A	N/A	N/A	N/A	N/A	N/A	N/A	Yes	N/A	Yes	Yes
Wide Rotate/Side Tilt Carriage 1829 mm (72") 309-4316/227-5748	N/A	Yes	Yes	Yes	Yes	Yes	Yes	Yes	Yes	Yes	Yes	Yes	Yes	Yes
Wide Tilt Carriage 1829 mm (72") 301-9758/174-7731	N/A	Yes	Yes	Yes	Yes	Yes	Yes	Yes	Yes	Yes	Yes	Yes	Yes	Yes
General Purpose Bucket:														
0.75 m ³ (0.98 yd ³) 207-5154	Yes	N/A	N/A	N/A	N/A	N/A	N/A	N/A	N/A	N/A	N/A	N/A	N/A	N/A
0.76 m ³ (1.0 yd ³) 330-4237	N/A	N/A	N/A	N/A	N/A	N/A	N/A	N/A	N/A	N/A	N/A	N/A	N/A	N/A
1.0 m ³ (1.3 yd ³) 163-4261	N/A	Yes	Yes	Yes	Yes	Yes	Yes	Yes	Yes	Yes	Yes	Yes	Yes	Yes
1.3 m ³ (1.75 yd ³) 194-2564/2563	N/A	N/A	N/A	N/A	N/A	N/A	N/A	N/A	Yes	Yes	Yes	Yes	Yes	Yes
Grapple Bucket:														
0.85 m ³ (1.1 yd ³) 461-7032	N/A	Yes	Yes	Yes	Yes	Yes	N/A	Yes	N/A	N/A	N/A	N/A	N/A	N/A
Light Material Bucket:														
0.8 m ³ (1.05 yd ³) 350-0505	Yes	N/A	N/A	N/A	N/A	N/A	N/A	N/A	N/A	N/A	N/A	N/A	N/A	N/A
1.3 m ³ (1.7 yd ³) 330-4236	N/A	N/A	N/A	N/A	N/A	N/A	N/A	N/A	N/A	N/A	N/A	N/A	N/A	N/A
2.0 m ³ (2.6 yd ³) 220-4759	N/A	Yes	Yes	Yes	Yes	N/A	N/A	N/A	N/A	N/A	N/A	N/A	N/A	N/A
2.5 m ³ (3.25 yd ³) 220-4670	N/A	Yes	Yes	Yes	Yes	N/A	N/A	N/A	N/A	N/A	N/A	N/A	N/A	N/A
3.0 m ³ (3.9 yd ³) 220-4761	N/A	Yes	Yes	Yes	Yes	N/A	N/A	N/A	N/A	N/A	N/A	N/A	N/A	N/A
Material Handling Bucket:														
1.5 m ³ (1.96 yd ³) 186-5838	N/A	N/A	N/A	Yes	Yes	Yes	N/A	N/A	Yes	Yes	Yes	Yes	Yes	Yes
Multi-Grapple Bucket:														
0.85 m ³ (1.11 yd ³) 219-5515	N/A	N/A	N/A	N/A	N/A	N/A	N/A	N/A	N/A	N/A	N/A	N/A	N/A	N/A
Multi-Purpose Bucket:														
0.37 m ³ (0.48 yd ³) 279-5399	N/A	N/A	N/A	N/A	N/A	N/A	N/A	N/A	N/A	N/A	N/A	N/A	N/A	N/A
1.0 m ³ (1.3 yd ³) 163-4265	N/A	Yes	Yes	Yes	Yes	Yes	N/A	N/A	Yes	Yes	Yes	Yes	Yes	Yes

	TH255C	TH336C	TH337C	TH406C	TH407C	TH414C	TH417C	TH514C	TL642C	TL943C	TL1055C	TL1255C	TL1055D	TL1255D
Pallet Fork — 45 mm (1.77") Diameter: 1067 mm (42") x 100 mm (4") 252-1454	Yes	Yes	Yes	Yes	Yes	Yes	Yes	N/A	N/A	N/A	N/A	N/A	N/A	N/A
Pallet Fork — 51 mm (2") Diameter: 1200 mm (47") x 100 mm (4") 309-9179/326-1997	Yes	Yes	Yes	Yes	Yes	Yes	Yes	N/A	N/A	N/A	N/A	N/A	N/A	N/A
1200 mm (47") x 125 mm (5") 364-5356	Yes	Yes	Yes	Yes	Yes	Yes	Yes	Yes	N/A	N/A	N/A	N/A	N/A	N/A
1220 mm (48") x 100 mm (4") 323-5738/252-1455	Yes	N/A	N/A	Yes	Yes	N/A	N/A	Yes	N/A	N/A	N/A	N/A	N/A	N/A
1220 mm (48") x 125 mm (5") 252-1459	N/A	N/A	N/A	Yes	Yes	N/A	N/A	Yes	N/A	N/A	N/A	N/A	N/A	N/A
1525 mm (60") x 100 mm (4") 252-1456	Yes	Yes	Yes	Yes	Yes	Yes	Yes	N/A	N/A	N/A	N/A	N/A	N/A	N/A
Pallet Fork — 60 mm (2.36") Diameter: 1220 mm (48") x 100 mm (4") 301-9755/326-1998	N/A	Yes	Yes	Yes	Yes	Yes	Yes	Yes	Yes	Yes	Yes	N/A	Yes	N/A
1220 mm (48") x 125 mm (5") 301-9753	N/A	N/A	N/A	N/A	N/A	N/A	N/A	N/A	Yes	Yes	Yes	Yes	Yes	Yes
1525 mm (60") x 150 mm (6") 301-9754	N/A	N/A	N/A	Yes	Yes	N/A	N/A	Yes	Yes	Yes	Yes	Yes	Yes	Yes
Block Fork — 50 mm (2") Diameter: 1220 mm (48") x 50 mm (2") 252-1460	Yes	Yes	Yes	Yes	Yes	Yes	Yes	Yes	Yes	Yes	Yes	Yes	Yes	Yes
Lumber Fork — 38 mm (1.5") Diameter: 1525 mm (60") x 150 mm (6") 323-5737	Yes	N/A	N/A	N/A	N/A	N/A	N/A	N/A	N/A	N/A	N/A	N/A	N/A	N/A
Lumber Fork — 45 mm (1.75") Diameter: 1525 mm (60") x 180 mm (7") 301-9756	N/A	N/A	N/A	Yes	Yes	N/A	N/A	N/A	Yes	Yes	Yes	N/A	Yes	N/A
Lumber Fork — 50 mm (2") Diameter: 1829 mm (72") x 150 mm (6") 311-2854	N/A	N/A	N/A	Yes	Yes	N/A	N/A	Yes	Yes	Yes	Yes	Yes	Yes	Yes
Lumber Fork — 60 mm (2.36") Diameter: 1525 mm (60") x 150 mm (6") 301-9754	N/A	N/A	N/A	Yes	Yes	N/A	N/A	N/A	Yes	Yes	Yes	Yes	Yes	Yes
Winch: 23 m (75 ft) 305-3773	N/A	N/A	N/A	N/A	N/A	N/A	N/A	N/A	Yes	Yes	Yes	Yes	Yes	Yes
46 m (150 ft) 305-3768	N/A	N/A	N/A	N/A	N/A	N/A	N/A	N/A	Yes	Yes	N/A	N/A	N/A	N/A

	TH255C	TH406C	TH407C	TH514C	TL642C	TL943C	TL1055C	TL1255C	TL1055D	TL1255D
Lifting Hook, Fork Mounted 321-0556	Yes	Yes	Yes	Yes	Yes	Yes	Yes	Yes	Yes	Yes
Lifting Hook, IT 169-6460	N/A	Yes	Yes	Yes	Yes	Yes	Yes	Yes	Yes	Yes
Manure Fork + Grab 2286 mm (90") 186-6054	N/A	Yes	Yes	N/A	N/A	N/A	N/A	N/A	N/A	N/A
Material Handling Arm	Yes	N/A	N/A	Yes	Yes	Yes	Yes	Yes	Yes	Yes
Truss Boom 169-3945	N/A	Yes	Yes	Yes	Yes	Yes	Yes	Yes	Yes	Yes
Work Platform, Fork Mounted 343-9739/9738	N/A	Yes	Yes	Yes	Yes	Yes	Yes	Yes	Yes	Yes
Standard Tilt Carriage 1220 mm (48") 350-9099	Yes	N/A	N/A	N/A	N/A	N/A	N/A	N/A	N/A	N/A
Standard Tilt Carriage 1270 mm (50") 301-9757	N/A	Yes	Yes	Yes	Yes	Yes	Yes	Yes	Yes	Yes
Standard Rotate/Tilt Carriage 1220 mm (48") 331-3251	Yes	N/A	N/A	N/A	N/A	N/A	N/A	N/A	N/A	N/A
Standard Rotate/Tilt Carriage 1270 mm (50") 309-4315	N/A	Yes	Yes	Yes	Yes	Yes	Yes	Yes	Yes	Yes
Sideshift Carriage 1220 mm (48") 314-8479/222-6210/331-3252	Yes	Yes	Yes	Yes	Yes	Yes	Yes	Yes	Yes	Yes
Swing Carriage, 100°, 1829 mm (72") 318-9222	N/A	Yes	Yes	Yes	Yes	Yes	Yes	Yes	Yes	Yes
Swing Carriage, 180°, 1829 mm (72") 341-3591	N/A	N/A	N/A	N/A	N/A	N/A	N/A	Yes	N/A	Yes
Wide Rotate/Side Tilt Carriage 1829 mm (72") 309-4316	N/A	Yes	Yes	Yes	Yes	Yes	Yes	Yes	Yes	Yes
Wide Tilt Carriage 1829 mm (72") 301-9758	N/A	Yes	Yes	Yes	Yes	Yes	Yes	Yes	Yes	Yes
General Purpose Bucket:										
0.75 m ³ (0.98 yd ³) 207-5154	Yes	N/A	N/A	N/A	N/A	N/A	N/A	N/A	N/A	N/A
0.76 m ³ (1.0 yd ³) 330-4237	Yes	N/A	N/A	N/A	N/A	N/A	N/A	N/A	N/A	N/A
1.0 m ³ (1.3 yd ³) 163-4261	N/A	Yes	Yes	Yes	Yes	Yes	Yes	Yes	Yes	Yes
1.3 m ³ (1.75 yd ³) 194-2564/2563	N/A	Yes	Yes	Yes	Yes	Yes	Yes	Yes	Yes	Yes
Grapple Bucket:										
0.76 m ³ (1.0 yd ³) 330-4240/158-6095/157-7225	Yes	N/A	N/A	N/A	N/A	N/A	N/A	N/A	N/A	N/A
Light Material Bucket:										
1.3 m ³ (1.7 yd ³) 330-4236	Yes	N/A	N/A	N/A	N/A	N/A	N/A	N/A	N/A	N/A
2.0 m ³ (2.6 yd ³) 220-4759	N/A	Yes	Yes	N/A	N/A	N/A	N/A	N/A	N/A	N/A
2.5 m ³ (3.25 yd ³) 220-4670	N/A	Yes	Yes	N/A	N/A	N/A	N/A	N/A	N/A	N/A
3.0 m ³ (3.9 yd ³) 220-4761	N/A	Yes	Yes	N/A	N/A	N/A	N/A	N/A	N/A	N/A
Material Handling Bucket:										
1.5 m ³ (1.96 yd ³) 186-5838	N/A	Yes	Yes	Yes	Yes	Yes	Yes	Yes	Yes	Yes
Multi-Grapple Bucket:										
0.85 m ³ (1.11 yd ³) 219-5515	N/A	Yes	Yes	N/A	N/A	N/A	N/A	N/A	N/A	N/A
Multi-Purpose Bucket:										
0.37 m ³ (0.48 yd ³) 279-5399	Yes	N/A	N/A	N/A	N/A	N/A	N/A	N/A	N/A	N/A
1.0 m ³ (1.3 yd ³) 163-4265	N/A	Yes	Yes	N/A	Yes	Yes	Yes	Yes	Yes	Yes

	TH255C	TH406C	TH407C	TH514C	TL642C	TL943C	TL1055C	TL1255C	TL1055D	TL1255D
Pallet Fork — 45 mm (1.77") Diameter: 1067 mm (42") x 100 mm (4") 252-1454	N/A	Yes	Yes	N/A	N/A	N/A	N/A	N/A	N/A	N/A
Pallet Fork — 51 mm (2") Diameter: 1200 mm (47") x 125 mm (5") 364-5356	N/A	Yes	Yes	N/A	N/A	N/A	N/A	N/A	N/A	N/A
1220 mm (48") x 100 mm (4") 323-5738/252-1455	Yes	Yes	Yes	Yes	N/A	N/A	N/A	N/A	N/A	N/A
1220 mm (48") x 125 mm (5") 252-1459	N/A	Yes	Yes	N/A	N/A	N/A	N/A	N/A	N/A	N/A
1525 mm (60") x 100 mm (4") 252-1456/326-1997	N/A	Yes	Yes	N/A	N/A	N/A	N/A	N/A	N/A	N/A
Pallet Fork — 60 mm (2.36") Diameter: 1220 mm (48") x 100 mm (4") 301-9755/326-1998	N/A	Yes	Yes	Yes	Yes	Yes	Yes	N/A	Yes	N/A
1220 mm (48") x 125 mm (5") 301-9753	N/A	N/A	N/A	N/A	Yes	Yes	Yes	Yes	Yes	Yes
1525 mm (60") x 150 mm (6") 301-9754	N/A	Yes	Yes	Yes	Yes	Yes	Yes	Yes	Yes	Yes
Block Fork — 50 mm (2") Diameter: 1220 mm (48") x 50 mm (2") 252-1460/301-9752	Yes	Yes	Yes	Yes	Yes	Yes	Yes	Yes	Yes	Yes
Lumber Fork — 38 mm (1.5") Diameter: 1525 mm (60") x 150 mm (6") 323-5737	Yes	N/A	N/A	N/A	N/A	N/A	N/A	N/A	N/A	N/A
Lumber Fork — 45 mm (1.75") Diameter: 1525 mm (60") x 180 mm (7") 301-9756	N/A	Yes	Yes	N/A	Yes	Yes	Yes	N/A	Yes	N/A
Lumber Fork — 50 mm (2") Diameter: 1829 mm (72") x 150 mm (6") 311-2854	N/A	Yes	Yes	Yes	Yes	Yes	Yes	Yes	Yes	Yes
Lumber Fork — 60 mm (2.36") Diameter: 1525 mm (60") x 150 mm (6") 301-9754	N/A	Yes	Yes	N/A	Yes	Yes	Yes	Yes	Yes	Yes
Winch: 23 m (75 ft) 305-3773	N/A	N/A	N/A	N/A	Yes	Yes	Yes	Yes	Yes	Yes
46 m (150 ft) 305-3768	N/A	N/A	N/A	N/A	Yes	Yes	N/A	N/A	N/A	N/A

TRACK LOADERS

CONTENTS

Features	18-1
Special Arrangements	18-7
Specifications	18-8
Performance Data	18-10
Machine Dimensions with General Purpose Bucket	18-19
Machine Dimensions with Multi-Purpose Bucket	18-20
Rippers/Scarifiers	18-21
Drawbar Curves	18-22
Extreme Slope Operation	18-23
SAE Loader Ratings	18-24
Estimating Cycle Time	18-25
Bucket Fill Factors	18-26
Recommended Operating Capacities	18-26
Loader Production	18-26
Estimating Bucket Load	18-26
Estimating Production	18-27
Alternative Machine Selection Method	18-27
Production and Machine Selection: Nomographs	18-28
Travel Time Charts	18-30
Production Estimating Table	18-31
Work Tools	18-32
Shoe Options	18-34

Features common to all D Series models (953D-963D-973D):

- **Improved serviceability.** All D Series Track-Type Loaders are equipped with a tiltable cab that allows complete service of the hydraulic system. Most daily maintenance checks are performed from the machine's right side, facilitating quick start up. Easy access to major components enhances serviceability and increase uptime.
- **Operator station.** Experience a high level of efficiency, comfort and productivity with the new D Series cab. The cab features a new gauge cluster, a fully air-suspension seat, the new seat mounted controls, an automatic air climate control and provides excellent visibility.
- **Messenger.** Messenger is a new electronic monitoring system with real time, visual feedback on engine and machine operating conditions. It provides information on diagnostic data, maintenance, and allows operating settings such as implement reactions.
- **Hydrostatic drive.** The closed loop hydrostatic drive with electronic control provides precise modulation for quick, smooth operation and superior maneuverability. Shorter cycle times, high efficiency, and excellent maneuverability results in increased productivity.

Features common to all D Series models (953D-963D-973D) (continued):

- **Steering controls.** All D Series Track Loaders are offered with a choice of either the traditional V-lever with pedal steering or joystick control. With joystick control both steering and transmission functions are managed using the joystick. The joystick handles includes three buttons. The yellow buttons are used to increase/decrease the travel speed of the machine. The black button activates the horn. There are four different settings for both forward and reverse with the speed displayed on the multifunctional dashboard. This pattern is commonly referred to as S-pattern steering. All Cat® D Series Track-Type Loaders (953D – 963D – 973D) provide the option of two different transmission control joystick configurations. All machines ship from the factory with the default S-Pattern like a Cat Skid Steer Loader. After the machine arrives at the dealership, it can be changed to C-Pattern by the Cat Electronic Technician service tool if required.
- **Electro-hydraulic implements controls.** The new electro-hydraulic implement controls provide the operator with responsive, smooth and precise control of bucket and lift arms.
- **Kickout settings.** Automatic kickouts are part of the electro-hydraulic controls; adjust from inside the cab with a simple rocker switch. Kickout stops are hydraulically cushioned for greater operator comfort and less material spillage.
- **Position Sensing Cylinder.** The D Series has electro-hydraulic implement controls for lower operator effort. The new position sensing cylinders allow setting detents at any positions from the cab. They feature also a load sensing implement pump which reduces engine power consumption.
- **Hydraulic on-demand fan.** The fan is a hydraulic demand type one with optional reversible function, operating in sucker mode. It gives the best efficiency and avoids also sucking the dust and debris coming from the outside into the cooling package.
- **Oscillating track roller frames** decrease ground shock, increase machine stability and improve traction.
- **Unmatched versatility** – excavates, loads, dozes, grades, clears, strips, backfills in all underfoot conditions including those that could damage tires.
- **Sound-suppressed, air-pressurized, resiliently mounted ROPS cab** for superior working environment.
- **Sealed loader linkage** extends lubrication intervals and reduces maintenance time.
- **Automatic bucket controls** let bucket rise to pre-set dumping height and return to pre-set digging angle for fast cycle time.
- **General Purpose and Multi-Purpose** buckets, quick couplers and many other work tools are available to increase versatility.
- **Rippers** are Multishank with wide beam coverage for utility ripping close to walls, footings and embankments. Three shanks are available for D Series Track Loaders.
- **Product Link™ System** reports machine location and hours and consequently makes the maintenance easier and reduces the downtime. Please check availability with your local dealer.
- **Cat Machine Security System** allows better machine protection by preventing theft. A microchip is embedded in the key to provide more security. Cat Machine Security System is an optional feature.
- **K System** is a Caterpillar exclusive which allows ease of installation and removal. New adapters provide better performance and offer a longer lasting life than J Series (+30%).
- **Special Application Arrangements.** Special arrangements — Waste Handling, Demolition, Wide Gauge and more, are available or can be designed on request, to allow the D Series to work in special applications.

Features of 953D-963D:

- **C6.6 ACERT™ Engine.** The Cat C6.6 ACERT engine utilizes the Cat Common Rail fuel delivery system. Designed for performance, durability, serviceability, and fuel economy, it meets U.S. EPA Tier 3, EU Stage IIIA and Japan 2006 (Tier 3) equivalent emission standards.
- **SystemOne™ Moving U/C.** The revolutionary Cat SystemOne Undercarriage provides maximum undercarriage life and reliability no matter the application, environment or underfoot conditions. Built to last longer and require less maintenance it ensures a dramatic drop in owning and operating costs.
- **Special Application Arrangements.** Ship Hold Arrangements are available on 953D-963D.

Features of 973D:

- **C9 ACERT Engine.** The Cat C9 ACERT engine is an 8.8 liter (537 in³) displacement, six-cylinder, in-line configured engine with hydraulically actuated electronic fuel injection or HEUI™. The 196 kW (263 hp) rated net power engine meets U.S. EPA Tier 3, EU Stage IIIA and Japan 2006 (Tier 3) equivalent emission standards.
- **Rear engine location** provides natural stability as a “working” counterweight, excellent visibility and good weight to horsepower ratio.
- **Electronic hydrostatic drive train with pedal steering** offers independent control of each track. Power turns, counterrotation infinitely variable speeds, and fast acceleration for increased maneuverability and production.
- **Variable displacement pump and motors** provide excellent efficiency and controllability.
- **Z-bar linkage** provides increased breakout force, fewer grease points and fast dump speed.
- **Special arrangements** including Wide Gauge, Waste Handling, Ship Hold, Tunneling and Steel Mill are available to tailor the machine to specific applications.
- **Special Application Arrangements.** The steel mill arrangement protects the 973D and its operator against extreme conditions to allow the machine to handle hot slag in steel mill operations. The special arrangement features additional guarding for critical components, sealed undercarriage, heat shields for fuel tank, power train and hydraulics, silicone seals and heat resistant windshield, remote parking brake release and fire-resistant fluids. The Steel Mill Arrangement provides the best protection available for this extremely difficult application.

Features of 963K:

- **Fuel efficiency.** A more fuel efficient Cat C7.1 ACERT engine and Eco Mode combine to give you a 10-30 percent reduction in fuel use.*
- **Performance.** Smarter power train management gives you power when you need it and improved implement and steering response.*
- **Ease of operation.** Cab updates offer added comfort and convenience for operators. New handles and steps make access/egress even easier from the front or the back of the tracks.
- **Technology.** Remote monitoring with Product Link/VisionLink® helps you manage your fleet more effectively and profitably.
- **Engine.** A Cat C7.1 ACERT engine gives you the power and reliability you need to get the job done. The engine is equipped with a twin turbo, providing faster machine response under load.
- **Fuel efficiency/Eco Mode.** The more efficient engine and an Eco Mode combine to deliver a 10-30 percent reduction in fuel consumption compared to the 963D. Eco Mode automatically reduces engine speed, but maintains selected ground speed under lighter loads. Efficient use of Diesel Exhaust Fluid (DEF) — typically 2.5-3 percent of fuel consumption — provides excellent overall fluid efficiency.

*Compared to the 963D.

- **Hydrostatic drive.** A new Electronic Control Module gives you smarter power train management, resulting in smoother implement/steering response and improved steering performance over the previous model. Power reaches the ground more efficiently based on the demands of the application, giving you fast acceleration and shorter cycle times. The electronically controlled Hystat drive uses variable displacement pumps and drive motors to power each track independently, delivering fast acceleration and infinitely variable speed. The operator can command smooth machine turns and counterrotation.
- **Cooling system.** The single unit cooling system incorporates the radiator, air-to-air aftercooler, oil cooler and fan installation. The cooling module is located at the rear of the loader, away from dust and debris stirred up by the bucket while the machine is working. The radiator has 6.5 fins per inch to help reduce plugging. A simple, side-by-side design reduces debris and makes cleaning easier. The fold-down design gives you easy access.

A hydraulic demand fan reduces speed in cooler conditions to conserve power, save fuel and decrease sound levels. An optional reversing fan is available for high debris conditions.
- **Load-sensing hydraulics.** Field-proven system senses the load and continuously adjusts hydraulic power to maximize your efficiency. Operators have precise control and the power needed for simultaneous lift, tilt and travel.

Features of 963K (continued):

- **Position sensing cylinders.** Position sensing cylinders allow the operator to set lift and tilt kickouts to match the application without leaving the cab. Linkage position can be automatically set to specific positions for increased productivity. Advanced automatic features help make start/stop motions smoother, reducing vibration in the cab.
 - **Automatic kickouts.** Standard programmable automatic kickouts provide flexibility and productivity for precise load and dump target heights. Tilt and lift kickouts are easily set by positioning the bucket or attachment and pressing a button on the right-hand control panel in the cab.
 - **Implement and steering controls.** Electro-hydraulic implement controls provide the operator with responsive, smooth and precise control of bucket and lift arms.
 - Choose from either joystick or two-lever implement controls to match operator preference or application.
 - Speed/steering controls are available as either a joystick or as V-lever and foot pedals.
 - A variable throttle control dial lets you use preset engine speeds, customize engine speeds for operator preference.
 - Selectable electro-hydraulic maps and hydrostatic transmission allow you to set implement response — fine, normal, coarse — to match operator preference or application.
 - Hydrostatic drive system provides quick machine travel speed, on-the-go directional changes and counterrotation.
 - **Aftertreatment technologies.** With millions of working hours on tens of thousands of units since the Tier 4 Interim/Stage IIIB product introductions, you can be confident in the quality and value of your Cat Tier 4 Final investment. To meet the reduction in NO_x emissions required by Tier 4 Final/Stage IV emission standards, Caterpillar engineers added Selective Catalytic Reduction (SCR) to the already proven aftertreatment solution.
 - **Diesel Exhaust Fluid.** Selective Catalytic Reduction utilizes Diesel Exhaust Fluid (DEF), which can be conveniently refilled from ground level when you refuel. The system is designed to use one tank of DEF for each tank of fuel (1:1 DEF fill ratio). A gauge on the dash shows your fluid level. Across a variety of applications, the 963K typically has used DEF at a rate of 2.5-3 percent of fuel consumption. When the machine is turned off, a pump will automatically purge the DEF lines. A symbol on the dash and a light/symbol in the engine compartment indicate when the purge is complete and that it is safe to turn off the electrical disconnect. If the engine/aftertreatment temperatures are high, a Delayed Engine Shutdown will activate automatically to cool the machine and then purge the lines.
 - **Buckets.** A choice of buckets help you optimize your machine for the work you do. The General Purpose bucket is designed for excellent loadability and long life in applications like hard bank excavating, stripping and stockpile loading. The Multipurpose bucket is designed for versatility, and is ideal for a variety of tasks like loading, stripping, clearing, bulldozing, picking up debris and fine grading. The bucket clamps hydraulically to grip or handle other tough-to-grasp materials.
- A new optional Performance Series bucket contributes to your productivity by moving 5-10 percent more material per hour. And for special applications, Caterpillar also offers buckets optimized for applications like waste/landfill and ship hold work.

Features of 963K (continued):

- **K Series™ bucket tooth tips.** The K Series tooth system stays sharp, holds tight and allows for simple changes. The lower-profile shape maintains optimal sharpness, penetration and digging ability throughout the tip life.
- **Quick coupler ready.** Fusion™ Quick Coupler option gives you more versatility by allowing easy use of forks, buckets, etc. from wheel loaders and other Fusion compatible machines.
- **Ripper.** The multi shank ripper adds extra versatility and force to expand the machine's range of applications. The ripper beam has three pockets for holding ripper shanks, and its design allows the machine to rip frozen ground, asphalt and even hard soils or rock. Long shanks deliver more work per pass making the machine more productive.
- **Safety.** New handles and steps help operators climb on and off the machine more easily, from the front or the back of the tracks.
 - Excellent visibility to the bucket and all around the machine helps operators work more confidently.
 - Rear vision camera is available to enhance visibility behind the machine.
 - New seat belt indicator gives an alarm and registers fault code through Product Link if the operator fails to buckle up, enhancing job site safety.
 - Improved ergonomics, a quieter engine and reduced effort controls help lessen fatigue so operators are better able to remain fresh and focused.
- **Serviceability.** The 963K is designed to help you take care of routine maintenance and get back to work.
 - Grouped service points are located behind large access doors, and daily grease points are in easy reach at ground level.
 - The tilt cab allows easy access to drive train and hydraulic systems.
 - The cooling system can be accessed from the engine compartment and features a fold-down fan for easy clean-out.
 - A handy bracket at the rear of the machine holds a shovel to help you clean the undercarriage.
 - The Diesel Particulate Filter in the Clean Emissions Module is designed to work for the life of the engine without needing to clean or replace the filter.
 - The service mode in the operator display shows you hydrostatic and implement pressure for easier troubleshooting and servicing.

Special Arrangements of 963K:

- **963K Waste Handler.** Designed and built from the frame up to take on the unique challenges of landfill and transfer station work.
 - Specialized guarding, striker bars and seals help protect the machine from impact and airborne debris.
 - Final drive guarding helps prevent wrapping and damage.
 - Cooling system is designed for high debris environments, with easy access for cleanout.
 - Specialized air handling features help deliver cleaner air to the machine and to the cab.
 - Landfill buckets and track options help you optimize your waste handler for the job.
- **963K SH Ship Hold/Port Handling.** Maneuverability, ease of operation and reach make a track loader the ideal machine for quickly removing materials from ship holds.
 - Sweep down walls and handle a wide variety of materials.
 - Specialized sealing, guards and bumpers help protect key components.
 - Added lighting packages help illuminate the work area.
 - Specialized implements, like coal buckets and trim blades, help you equip the machine for optimal performance.
 - Fusion Quick Coupler option gives you more versatility by allowing easy use of forks, buckets, etc. from wheel loaders and other Fusion compatible machines.
 - Lift eyes on the frame and undercarriage are widely spaced for stability during lifting.
- **Custom Products/Value Packages.** Caterpillar offers a variety of custom product options for track loaders, such as wide gauge machines and special guarding packages.

MODEL	953D		963D	
Emission Standards	Tier 3, Stage IIIA, Japan 2006 (Tier 3) equivalent		Tier 3, Stage IIIA, Japan 2006 (Tier 3) equivalent	
Flywheel Power	110 kW	148 hp	141 kW	189 hp
Operating Weight*	15 517 kg	34,209 lb	20 220 kg	44,577 lb
Engine Model	C6.6 ACERT		C6.6 ACERT	
Rated Engine RPM	2000		2000	
Bore	105 mm	4"	105 mm	4.13"
Stroke	127 mm	5"	127 mm	5"
No. Cylinders	6		6	
Displacement	6.6 L	402.7 in³	6.6 L	402.7 in³
Speeds Forward/Reverse	km/h	mph	km/h	mph
1st	0-10	0-6.2	0-10	0-6.2
2nd	Infinitely		Infinitely	
3rd	Variable		Variable	
Hydraulic Cycle Time, Bucket Empty, in Seconds:				
Raise	5.9		5.8	
Dump	1.5		1.3	
Lower (Empty, Float Down)	3.2		2.9	
Track Rollers (Each Side)	6		7	
Width of Standard Track Shoe	480 mm	19"	550 mm	21.6"
Length of Track on Ground	2323 mm	91.4"	2543 mm	100.1"
Ground Contact Area (with Standard Shoes)	2.3 m ²	3565 in²	2.8 m ²	4340 in²
Ground Pressure	65.5 kPa	9.5 psi	71.5 kPa	10.3 psi
Ground Clearance	416 mm	16.3"	471 mm	18.5"
Track Gauge	1800 mm	71"	1850 mm	72.8"
Width without Bucket (with Standard Shoes)	2280 mm	89.7"	2400 mm	94.5"
Fuel Tank Refill Capacity	316 L	83.5 U.S. gal	400 L	105.6 U.S. gal
Hydraulic System Refill Capacity	70 L	18.5 U.S. gal	90 L	23.8 U.S. gal

*953D and 963D weights include GP bucket with bolt-on adapters, long tips and segments.

Except for Steel Mill Arrangement — Fuel Tank Refill Capacity is 422 L (111.4 U.S. gal**).

MODEL	973D		963K	
Emission Standards	Tier 3, Stage IIIA, Japan 2006 (Tier 3) equivalent		Tier 4 Final/Stage IV/Japan 2014 (Tier 4 Final)/Korea Tier 4 Final	
Flywheel Power	196 kW	263 hp	144 kW	193 hp
Operating Weight	28 058 kg	61,857 lb	20 308 kg	44,771 lb
Engine Model	C9 ACERT		C7.1 ACERT	
Rated Engine RPM	1900		1800	
Bore	112 mm	4.41"	105 mm	4.13"
Stroke	149 mm	5.87"	135 mm	5.31"
No. Cylinders	6		6	
Displacement	8.8 L	537 in³	7.01 L	427.8 in³
Speeds Forward/Reverse	km/h	mph	km/h	mph
1st	0-11	0-6.8	0-10	0-6.2
2nd	Infinitely		Infinitely	
3rd	Variable		Variable	
Hydraulic Cycle Time, Bucket Empty, in Seconds:				
Raise	6.5		5.5	
Dump	1.4		1.3	
Lower (Empty, Float Down)	2.7		2.0	
Track Rollers (Each Side)	7		7	
Width of Standard Track Shoe	550 mm	21.7"	550 mm	21.6"
Length of Track on Ground	2930 mm	115"	2543 mm	100.1"
Ground Contact Area (with Standard Shoes)	3.22 m ²	4991 in²	2.8 m ²	4340 in²
Ground Pressure	85.5 kPa	12.0 psi	71.5 kPa	10.3 psi
Ground Clearance	482 mm	18.98"	471 mm	18.5"
Track Gauge	2160 mm	85"	1850 mm	72.8"
Width without Bucket (with Standard Shoes)	2710 mm	106.7"	2400 mm	94.5"
Fuel Tank Refill Capacity	621 L*	164.1 U.S. gal*	320 L	84.5 U.S. gal
Hydraulic System Refill Capacity	189 L	49.9 U.S. gal	90 L	23.8 U.S. gal

*Except for Steel Mill Arrangement — Fuel Tank Refill Capacity is 422 L (111.4 U.S. gal).

BUCKET	General Purpose Bare		General Purpose Bolt-on Adapters, Long Teeth & Segments		General Purpose Bolt-on Cutting Edge		General Purpose Flush Weld-on Adapters & Long Teeth	
	Capacity, Rated (Nominal Heaped)	1.75 m ³	2.29 yd³	1.85 m ³	2.42 yd³	1.85 m ³	2.42 yd³	1.85 m ³
Struck	1.45 m ³	1.90 yd³	1.55 m ³	2.03 yd³	1.55 m ³	2.03 yd³	1.45 m ³	1.90 yd³
Cutting Edge, Type	Straight		Straight		Straight		—	
Bucket Width ◀	2392 mm	94.2"	2485 mm	97.8"	2395 mm	94.3"	2438 mm	96"
Teeth	None		8, bolt-on plus replaceable tips		None		8, bolt-on plus replaceable tips	
Dump Clearance @ Full Lift and 45° Discharge	2855 mm	112.4"	2616 mm	102.9"	2786 mm	109.6"	2659 mm	104.7"
Reach at 45° Discharge Angle 2133 mm (7'0") Clearance	1550 mm	61"	1630 mm	64.2"	1559 mm	61.4"	1656 mm	65.2"
Reach @ Full Lift and 45° Discharge	928 mm	36.5"	1099 mm	43.3"	961 mm	37.8"	1104 mm	43.5"
Digging Depth	92 mm	3.6"	140 mm	5.5"	117 mm	4.6"	105 mm	4.1"
Ground Clearance from Face of Shoes	416 mm	16.3"	416 mm	16.3"	416 mm	16.3"	416 mm	16.3"
Overall Machine Width without Bucket (with Standard Track) 480 mm (19")	2280 mm	89.7"	2280 mm	89.7"	2280 mm	89.7"	2280 mm	89.7"
Overall Machine Width without Bucket (with Narrow Track) 380 mm (15")	2180 mm	85.8"	2180 mm	85.8"	2180 mm	85.8"	2180 mm	85.8"
Overall Length	5926 mm	233.3"	6252 mm	246.1"	6017 mm	236.9"	6198 mm	244"
Overall Height	3105 mm	122.2"	3105 mm	122.2"	3105 mm	122.2"	3105 mm	122.2"
Static Tipping Load	11 431 kg	25,201 lb	11 089 kg	24,447 lb	11 252 kg	24,806 lb	11 255 kg	24,813 lb
Breakout Force*	160.5 kN	36,092 lb	157.8 kN	35,491 lb	159.3 kN	35,828 lb	162.5 kN	36,549 lb
Operating Weight**	15 517 kg	34,209 lb	15 758 kg	34,740 lb	15 638 kg	34,475 lb	15 635 kg	34,469 lb

* Breakout force is measured 100 mm (3.94") behind tip of cutting edge with bucket hinge pin as pivot point.

** Operating weight includes coolant, lubricants, full fuel tank, ROPS cab, bucket, and 75 kg (165 lb) operator.

◀ Bolt-on teeth increase bucket width by 52 mm (2"). Bolt-on cutting edge increases bucket width by 17 mm (0.67").

Machine stability can be affected by the addition of other attachments. Add or subtract the following to/from machine operating weight and static tipping load:

	Change in Operating Weight		Change in Static Tipping Load for General Purpose Bucket	
	kg	lb	kg	lb
Ripper (includes ripper, rear lines, and third valves)	+461	+1016	+967	+2131
Air conditioner	Standard		Standard	
Wide track shoes, 480 mm (19") double grouser	-588	-1296	-405	- 892
Rear bumper (removal)	-185	- 408	-411	- 906

BUCKET	Multi-Purpose Bare		Multi-Purpose Bolt-on Adapters, Long Tips & Segments		Multi-Purpose Bolt-on Cutting Edge	
Capacity, Rated (Nominal Heaped)	1.5 m ³	1.96 yd³	1.6 m ³	2.09 yd³	1.6 m ³	2.09 yd³
Struck	1.25 m ³	1.63 yd³	1.35 m ³	1.76 yd³	1.35 m ³	1.76 yd³
Cutting Edge, Type	Straight		Straight		Straight	
Bucket Width◀	2378 mm	93.6"	2471 mm	97.3"	2395 mm	94.3"
Teeth	None		8, bolt-on plus replaceable tips		None	
Dump Clearance @ Full Lift and 45° Discharge	2738 mm	107.7"	2499 mm	98.3"	2669 mm	105"
Reach at 45° Discharge Angle 2133 mm (7'0") Clearance	1434 mm	56.5"	1457 mm	57.4"	1428 mm	56.2"
Reach @ Full Lift and 45° Discharge	973 mm	38.3"	1144 mm	45"	1006 mm	39.6"
Digging Depth	142 mm	5.6"	190 mm	7.5"	147 mm	5.8"
Overall Length	6077 mm	239.3"	6401 mm	252"	6167 mm	242.8"
Overall Height	3105 mm	122.2"	3105 mm	122.2"	3105 mm	122.2"
Static Tipping Load	10 831 kg	23,878 lb	10 492 kg	23,130 lb	10 663 kg	23,507 lb
Breakout Force*	137.2 kN	30,843 lb	134.3 kN	30,191 lb	135.5 kN	30,461 lb
Operating Weight**	16 062 kg	35,410 lb	16 302 kg	35,939 lb	16 183 kg	35,677 lb

* Breakout force is measured 100 mm (3.94") behind tip of cutting edge with bucket hinge pin as pivot point.

** Operating weight includes coolant, lubricants, full fuel tank, ROPS cab, General Purpose bucket, and 80 kg (176 lb) operator.

◀ Bolt-on teeth increase bucket width by 52 mm (2"). Bolt-on cutting edge increases bucket width by 17 mm (0.67").

Machine stability can be affected by the addition of other attachments.

BUCKET	General Purpose Bare		General Purpose Bolt-on Cutting Edge		General Purpose Flush Weld-on Adapters & Long Tips		General Purpose Bolt-on Adapters, Long Tips & Segments	
Capacity, Rated (Nominal Heaped)	2.3 m ³	3.0 yd³	2.45 m ³	3.2 yd³	2.45 m ³	3.2 yd³	2.45 m ³	3.2 yd³
Struck	2.0 m ³	2.6 yd³	2.14 m ³	2.8 yd³	2.0 m ³	2.6 yd³	2.14 m ³	2.8 yd³
Cutting Edge, Type	Straight		Straight		—		Straight	
Bucket Width*	2508 mm	98.7"	2539 mm	99.9"	2583 mm	101.6"	2612 mm	102.8"
Teeth	None		None		8, weld-on plus replaceable tips		8, weld-on plus replaceable tips	
Dump Clearance @ Full Lift and 45° Discharge	3155 mm	124.2"	3068 mm	120.7"	2951 mm	116.1"	2915 mm	114.7"
Reach at 45° Discharge Angle 2133 mm (7'0") Clearance	1771 mm	69.7"	1793 mm	70.5"	1926 mm	75.8"	1886 mm	74.2"
Reach @ Full Lift and 45° Discharge	1060 mm	41.7"	1215 mm	47.8"	1397 mm	55"	1373 mm	54"
Digging Depth	80 mm	3.1"	115 mm	4.5"	95 mm	3.7"	138 mm	5.4"
Ground Clearance from Face of Shoes	471 mm	18.5"	471 mm	18.5"	471 mm	18.5"	471 mm	18.5"
Overall Machine Width without Bucket (with Standard Track) 550 mm (21.6")	2400 mm	94.5"	2400 mm	94.5"	2400 mm	94.5"	2400 mm	94.5"
Overall Machine Width without Bucket (with Narrow Track) 450 mm (18")	2300 mm	90.5"	2300 mm	90.5"	2300 mm	90.5"	2300 mm	90.5"
Overall Length	6584 mm	259.2"	6676 mm	262.8"	6883 mm	270.9"	6896 mm	271.4"
Overall Height	3335 mm	131.3"	3335 mm	131.3"	3335 mm	131.3"	3335 mm	131.3"
Static Tipping Load	14 969 kg	33,000 lb	14 685 kg	32,375 lb	14 815 kg	32,661 lb	14 482 kg	31,927 lb
Breakout Force**	208.6 kN	46,895 lb	206.1 kN	46,333 lb	207.4 kN	46,625 lb	203.8 kN	45,816 lb
Operating Weight***	20 220 kg	44,585 lb	20 433 kg	45,055 lb	20 332 kg	44,832 lb	20 592 kg	45,405 lb

*With bolt-on cutting edge add 17 mm (0.67"), with bolt-on teeth add 52 mm (2"), for flush weld-on teeth add 75 mm (3").

**Breakout force is measured 100 mm (3.94") behind tip of cutting edge with bucket hinge pin as pivot point.

***Operating weight includes coolant, lubricants, full fuel tank, ROPS cab, bucket, and 75 kg (165 lb) operator.

Machine stability can be affected by the addition of other attachments. Add or subtract the following to/from machine operating weight and static tipping load:

	Change in Operating Weight		Change in Static Tipping Load for General Purpose Bucket	
	kg	lb	kg	lb
Ripper (includes ripper, rear lines, and third valves)	+639	+1409	+1421	+3133
Rear bumper (removal)	-195	- 430	- 464	-1023

BUCKET	Multi-Purpose Bare		Multi-Purpose Bolt-on Segments & Long Teeth		Multi-Purpose Bolt-on Cutting Edge	
Capacity, Rated (Nominal Heaped)	1.9 m ³	2.5 yd ³	2.0 m ³	2.6 yd ³	2.0 m ³	2.6 yd ³
Struck	1.6 m ³	2.1 yd ³	1.7 m ³	2.2 yd ³	1.7 m ³	2.2 yd ³
Cutting Edge, Type	Straight		Straight		Straight	
Bucket Width*	2482 mm	97.7"	2575 mm	101.3"	2515 mm	99"
Teeth	None		8, bolt-on plus replaceable tips		None	
Dump Clearance @ Full Lift and 45° Discharge	3000 mm	118.1"	2772 mm	109.1"	2909 mm	114.5"
Reach at 45° Discharge Angle 2133 mm (7'0") Clearance	1598 mm	62.9"	1650 mm	65.0"	1607 mm	63.3"
Reach @ Full Lift and 45° Discharge	1065 mm	41.9"	1240 mm	48.8"	1119 mm	44"
Digging Depth	161 mm	6.3"	209 mm	8.2"	191 mm	7.5"
Ground Clearance from Face of Shoes	471 mm	18.5"	471 mm	18.5"	471 mm	18.5"
Overall Machine Width without Bucket (with Standard Track) 550 mm (21.6")	2400 mm	94.5"	2400 mm	94.5"	2400 mm	94.5"
Overall Machine Width without Bucket (with Narrow Track) 450 mm (18")	2300 mm	90.5"	2300 mm	90.5"	2300 mm	90.5"
Overall Length	6698 mm	263.7"	7013 mm	276.1"	6820 mm	268.5"
Overall Height	3335 mm	131.3"	3335 mm	131.3"	3335 mm	131.3"
Static Tipping Load	14 487 kg	31,944 lb	14 124 kg	31,143 lb	14 208 kg	31,329 lb
Breakout Force**	193.2 kN	43,333 lb	189.2 kN	42,533 lb	193.7 kN	43,545 lb
Operating Weight***	20 710 kg	45,666 lb	20 975 kg	46,250 lb	20 911 kg	46,109 lb

*With bolt-on cutting edge add 17 mm (0.67"), for bolt-on teeth add 52 mm (2").

**Breakout force is measured 100 mm (3.94") behind tip of cutting edge with bucket hinge pin as pivot point.

***Operating weight includes coolant, lubricants, full fuel tank, ROPS cab, bucket, and 75 kg (165 lb) operator.

Machine stability can be affected by the addition of other attachments.

BUCKET	General Purpose Bare		General Purpose Bolt-on Adapters, Long Tips & Segments		General Purpose Bolt-on Cutting Edge		General Purpose Flush Weld-on Adapters & Long Tips	
Capacity, Rated (Nominal Heaped)	2.86 m ³	3.74 yd³	3.21 m ³	4.20 yd³	3.04 m ³	3.98 yd³	3.21 m ³	4.20 yd³
Struck	2.44 m ³	3.19 yd³	2.81 m ³	3.68 yd³	2.66 m ³	3.48 yd³	2.81 m ³	3.68 yd³
Cutting Edge, Type	Straight		Straight		Straight		Spade	
Bucket Width◀	2910 mm	114.6"	2910 mm	114.6"	2910 mm	114.6"	2990 mm	117.7"
Teeth	None		8, bolt-on plus replaceable tips		None		8, weld-on plus replaceable tips	
Dump Clearance @ Full Lift and 45° Discharge	3375 mm	132.9"	3013 mm	118.6"	3193 mm	125.7"	3069 mm	120.8"
Reach @ 45° Discharge Angle 2133 mm (7'0") Clearance	1839 mm	72.4"	2065 mm	81.3"	1929 mm	75.9"	2110 mm	83.1"
Reach @ Full Lift and 45° Discharge	1165 mm	45.9"	1327 mm	52.2"	1199 mm	47.2"	1357 mm	53.4"
Digging Depth	97 mm	3.8"	159 mm	6.3"	127 mm	5.0"	129 mm	5.1"
Ground Clearance from Face of Shoes	483 mm	19.0"	483 mm	19.0"	483 mm	19.0"	483 mm	19.0"
Overall Machine Width without Bucket (with Standard Track)	2710 mm	106.7"	2710 mm	106.7"	2710 mm	106.7"	2710 mm	106.7"
Overall Machine Width without Bucket (with Optional Track)	2835 mm	111.6"	2835 mm	111.6"	2835 mm	111.6"	2835 mm	111.6"
Overall Length	7194 mm	283.2"	7305 mm	287.6"	7275 mm	286.4"	7479 mm	294.4"
Overall Height	3510 mm	138.2"	3510 mm	138.2"	3510 mm	138.2"	3510 mm	138.2"
Static Tipping Load***	21 179 kg	46,700 lb	20 831 kg	45,932 lb	20 959 kg	46,215 lb	21 006 kg	46,318 lb
Breakout Force*	281 kN	63,225 lb	220 kN	49,500 lb	261 kN	58,725 lb	—	—
Operating Weight**	27 371 kg	60,353 lb	27 744 kg	61,176 lb	27 648 kg	60,964 lb	27 478 kg	60,589 lb

*Breakout force is measured 100 mm (3.94") behind tip of cutting edge with bucket hinge pin as pivot point.
 **Operating weight includes lubricants, full fuel tank, ROPS cab, General Purpose bucket, and 80 kg (176 lb) operator.
 ***Safe operating bucket load as defined by SAE for Track Loaders should not exceed 35% of static tipping load.
 ◀Bolt-on teeth increase bucket width by 63.8 mm (2.5"). Bolt-on cutting edge increases bucket width by 19 mm (0.74").

Machine stability can be affected by the addition of other attachments. Add or subtract the following to/from machine operating weight and static tipping load:

	Change in Operating Weight		Change in Static Tipping Load	
	kg	lb	kg	lb
Ripper (includes 3 shanks and rear hydraulic arrangement)	—	—	—	—
Rear bumper (removal)	—	—	—	—

BUCKET	Multi-Purpose Bare		Multi-Purpose Bolt-on Segments & Long Teeth		Multi-Purpose Bolt-on Cutting Edge	
Capacity, Rated (Nominal Heaped)	2.75 m ³	3.60 yd³	3.05 m ³	3.99 yd³	2.86 m ³	3.74 yd³
Struck	2.33 m ³	3.05 yd³	2.7 m ³	3.53 yd³	2.44 m ³	3.19 yd³
Cutting Edge, Type	Straight		Straight		Straight	
Bucket Width◀	2972 mm	117.0"	2972 mm	117.0"	2972 mm	117.0"
Teeth	None		8, bolt-on plus replaceable tips		None	
Dump Clearance @ Full Lift and 45° Discharge	3300 mm	129.9"	3106 mm	122.3"	3229 mm	127.1"
Reach @ 45° Discharge Angle 2133 mm (7'0") Clearance	2110 mm	83.1"	2327 mm	91.6"	2160 mm	85.0"
Digging Depth	188 mm	7.4"	244 mm	9.6"	219 mm	8.6"
Ground Clearance from Face of Shoes	582 mm	22.9"	582 mm	22.9"	582 mm	22.9"
Overall Machine Width without Bucket (with Standard Track)	2710 mm	106.7"	2710 mm	106.7"	2710 mm	106.7"
Overall Machine Width without Bucket (with Optional Track)	2835 mm	111.6"	2835 mm	111.6"	2835 mm	111.6"
Overall Length	7445 mm	293.1"	7743 mm	304.8"	7527 mm	296.3"
Overall Height	3510 mm	138.2"	3510 mm	138.2"	3510 mm	138.2"
Static Tipping Load	19 810 kg	43,681 lb	19 455 kg	42,898 lb	19 535 kg	43,075 lb
Breakout Force*	236 kN	53,100 lb	193 kN	43,425 lb	222 kN	49,950 lb
Operating Weight**	28 866 kg	63,650 lb	29 225 kg	64,441 lb	29 143 kg	64,260 lb

* Breakout force is measured 100 mm (3.94") behind tip of cutting edge with bucket hinge pin as pivot point.

** Operating weight includes lubricants, full fuel tank, ROPS cab, General Purpose bucket, and 80 kg (176 lb) operator.

◀ Bolt-on teeth increase bucket width by 63.8 mm (2.5"). Bolt-on cutting edge increases bucket width by 19 mm (0.74").

Machine stability can be affected by the addition of other attachments.

BUCKET	General Purpose Bare		General Purpose Bolt-on Cutting Edge		General Purpose Flush Weld-on Adapters & Long Tips	
Capacity, Rated (Nominal Heaped)	2.3 m ³	3.0 yd³	2.45 m ³	3.2 yd³	2.45 m ³	3.2 yd³
Struck	2.0 m ³	2.6 yd³	2.14 m ³	2.8 yd³	2.0 m ³	2.6 yd³
Cutting Edge, Type	Straight		Straight		—	
Bucket Width*	2508 mm	98.7"	2539 mm	99.9"	2583 mm	101.6"
Teeth	None		None		8, weld-on plus replaceable tips	
Dump Clearance @ Full Lift and 45° Discharge	3155 mm	124.2"	3068 mm	120.7"	2951 mm	116.1"
Reach at 45° Discharge Angle 2133 mm (7'0") Clearance	1771 mm	69.7"	1793 mm	70.5"	1926 mm	75.8"
Reach @ Full Lift and 45° Discharge	1060 mm	41.7"	1215 mm	47.8"	1397 mm	55"
Digging Depth	80 mm	3.1"	115 mm	4.5"	95 mm	3.7"
Ground Clearance from Face of Shoes	471 mm	18.5"	471 mm	18.5"	471 mm	18.5"
Overall Machine Width without Bucket (with Standard Track) 550 mm (21.6")	2400 mm	94.5"	2400 mm	94.5"	2400 mm	94.5"
Overall Machine Width without Bucket (with Narrow Track) 450 mm (18")	2300 mm	90.5"	2300 mm	90.5"	2300 mm	90.5"
Overall Length	6644 mm	261.6"	6766 mm	266.4"	6967 mm	274.3"
Overall Height	3325 mm	130.9"	3325 mm	130.9"	3325 mm	130.9"
Static Tipping Load	14 969 kg	33,000 lb	14 685 kg	32,375 lb	14 815 kg	32,661 lb
Breakout Force**	208.6 kN	46,895 lb	206.1 kN	46,333 lb	207.4 kN	46,625 lb
Operating Weight***	20 308 kg	44,771 lb	20 509 kg	45,215 lb	20 408 kg	44,992 lb

*With bolt-on cutting edge add 17 mm (0.67"), with bolt-on teeth add 52 mm (2"), for flush weld-on teeth add 75 mm (3").

**Breakout force is measured 100 mm (3.94") behind tip of cutting edge with bucket hinge pin as pivot point.

***Operating weight includes coolant, lubricants, full fuel tank, ROPS cab, bucket, and 75 kg (165 lb) operator.

Machine stability can be affected by the addition of other attachments. Add or subtract the following to/from machine operating weight and static tipping load:

	Change in Operating Weight		Change in Static Tipping Load for General Purpose Bucket	
	kg	lb	kg	lb
Ripper (includes ripper, rear lines, and third valves)	+639	+1409	+1421	+3133
Rear bumper (removal)	-195	- 430	- 464	-1023

BUCKET	General Purpose Bolt-on Adapters, Long Tips & Segments		Performance Series Bolt-on Adapters, Long Teeth & Segments	
Capacity, Rated (Nominal Heaped)	2.45 m ³	3.2 yd³	2.8 m ³	3.7 yd³
Struck	2.14 m ³	2.8 yd³	2.5 m ³	3.3 yd³
Cutting Edge, Type	Straight		Straight	
Bucket Width*	2612 mm	102.8"	2712 mm	106.8"
Teeth	8, weld-on plus replaceable tips		8, bolt-on plus replaceable tips	
Dump Clearance @ Full Lift and 45° Discharge	2915 mm	114.7"	2840 mm	111.8"
Reach at 45° Discharge Angle 2133 mm (7'0") Clearance	1886 mm	74.2"	1824 mm	71.8"
Reach @ Full Lift and 45° Discharge	1373 mm	54"	1298 mm	51.1"
Digging Depth	138 mm	5.4"	138 mm	5.4"
Ground Clearance from Face of Shoes	471 mm	18.5"	471 mm	18.5"
Overall Machine Width without Bucket (with Standard Track) 550 mm (21.6")	2400 mm	94.5"	2400 mm	94.5"
Overall Machine Width without Bucket (with Narrow Track) 450 mm (18")	2300 mm	90.5"	2300 mm	90.5"
Overall Length	7001 mm	275.6"	7107 mm	279.8"
Overall Height	3325 mm	130.9"	3325 mm	130.9"
Static Tipping Load	14 482 kg	31,927 lb	14 377 kg	31,696 lb
Breakout Force**	203.8 kN	45,816 lb	185.3 kN	41,651 lb
Operating Weight***	20 668 kg	45,565 lb	20 753 kg	45,753 lb

*With bolt-on cutting edge add 17 mm (**0.67"**), with bolt-on teeth add 52 mm (**2"**), for flush weld-on teeth add 75 mm (**3"**).

Breakout force is measured 100 mm (3.94"**) behind tip of cutting edge with bucket hinge pin as pivot point.

***Operating weight includes coolant, lubricants, full fuel tank, ROPS cab, bucket, and 75 kg (**165 lb**) operator.

Machine stability can be affected by the addition of other attachments. Add or subtract the following to/from machine operating weight and static tipping load:

	Change in Operating Weight		Change in Static Tipping Load for General Purpose Bucket	
	kg	lb	kg	lb
Ripper (includes ripper, rear lines, and third valves)	+639	+1409	+1421	+3133
Rear bumper (removal)	-195	- 430	- 464	-1023

BUCKET	Multi-Purpose Bare		Multi-Purpose Bolt-on Segments & Long Teeth		Multi-Purpose Bolt-on Cutting Edge	
Capacity, Rated (Nominal Heaped)	1.9 m ³	2.5 yd ³	2.0 m ³	2.6 yd ³	2.0 m ³	2.6 yd ³
Struck	1.6 m ³	2.1 yd ³	1.7 m ³	2.2 yd ³	1.7 m ³	2.2 yd ³
Cutting Edge, Type	Straight		Straight		Straight	
Bucket Width*	2482 mm	97.7"	2575 mm	101.3"	2515 mm	99"
Teeth	None		8, bolt-on plus replaceable tips		None	
Dump Clearance @ Full Lift and 45° Discharge	3000 mm	118.1"	2772 mm	109.1"	2909 mm	114.5"
Reach at 45° Discharge Angle 2133 mm (7'0") Clearance	1598 mm	62.9"	1650 mm	65.0"	1607 mm	63.3"
Reach @ Full Lift and 45° Discharge	1065 mm	41.9"	1240 mm	48.8"	1119 mm	44"
Digging Depth	161 mm	6.3"	209 mm	8.2"	191 mm	7.5"
Ground Clearance from Face of Shoes	471 mm	18.5"	471 mm	18.5"	471 mm	18.5"
Overall Machine Width without Bucket (with Standard Track) 550 mm (21.6")	2400 mm	94.5"	2400 mm	94.5"	2400 mm	94.5"
Overall Machine Width without Bucket (with Narrow Track) 450 mm (18")	2300 mm	90.5"	2300 mm	90.5"	2300 mm	90.5"
Overall Length	6758 mm	266.1"	7073 mm	278.5"	6880 mm	270.9"
Overall Height	3325 mm	130.9"	3325 mm	130.9"	3325 mm	130.9"
Static Tipping Load	14 487 kg	31,944 lb	14 124 kg	31,143 lb	14 208 kg	31,329 lb
Breakout Force**	193.2 kN	43,333 lb	189.2 kN	42,533 lb	193.7 kN	43,545 lb
Operating Weight***	20 786 kg	45,825 lb	21 051 kg	46,410 lb	20 987 kg	46,268 lb

*With bolt-on cutting edge add 17 mm (0.67"), for bolt-on teeth add 52 mm (2").

**Breakout force is measured 100 mm (3.94") behind tip of cutting edge with bucket hinge pin as pivot point.

***Operating weight includes coolant, lubricants, full fuel tank, ROPS cab, bucket, and 75 kg (165 lb) operator.

Machine stability can be affected by the addition of other attachments.

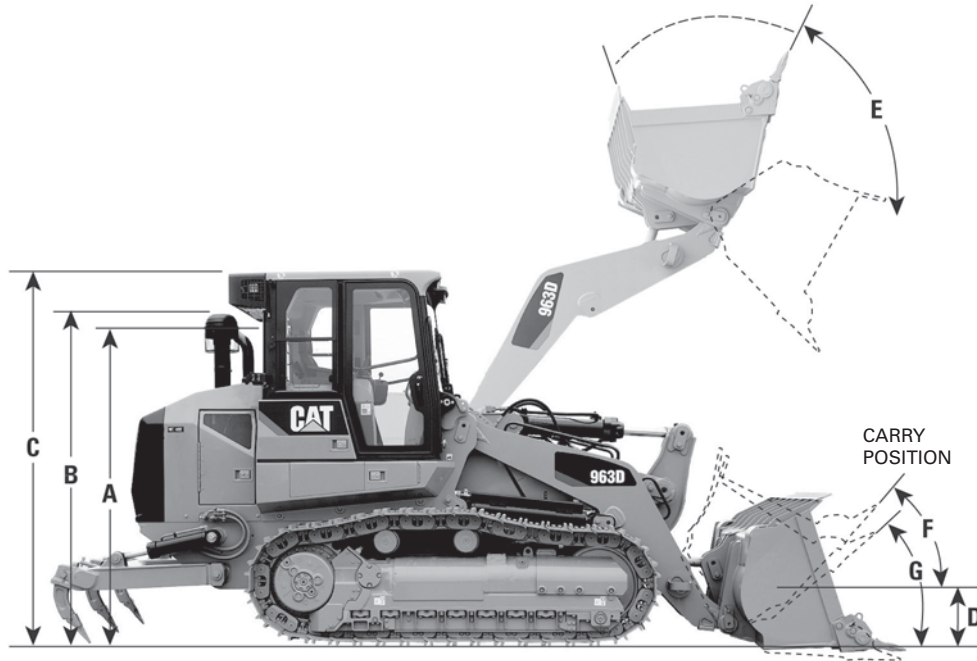

	953D		963D		973D		963K	
A Height to Top of Seat	2560 mm	100.7"	2790 mm	109.8"	2975 mm	117.1"	2808 mm	110.6"
B Height to Top of Stack	2783.5 mm	109.6"	2953 mm	116"	3018 mm	118.8"	2940 mm	115.7"
C Height to Top of ROPS	3105 mm	122.2"	3335 mm	131"	3510 mm	138.2"	3325 mm	130.9"
D Hinge Pin Height at Carry Position	421 mm	16.5"	467 mm	18"	483 mm	19.0"	457 mm	18"
E Rollback at Maximum Lift	56°		52°		59°		52°	
F Rollback at Carry Height	48°		50°		49°		50°	
G Rollback at Ground Level	41°		43°		42°		43°	
Grading Angle (Bare Edge)	74°		63°		85°		63°	
Width without Bucket (standard track)	2280 mm	89.7"	2400 mm	94"	2710 mm	106.7"	2400 mm	94"
(optional track)	2180 mm	85.8"	2300 mm	90.5"	2835 mm	111.6"	2300 mm	90.5"
Weight of General Purpose Bucket with Teeth & Segments	1266 kg	2792 lb	1866 kg	4114 lb	2090 kg	4608 lb	1866 kg	4114 lb

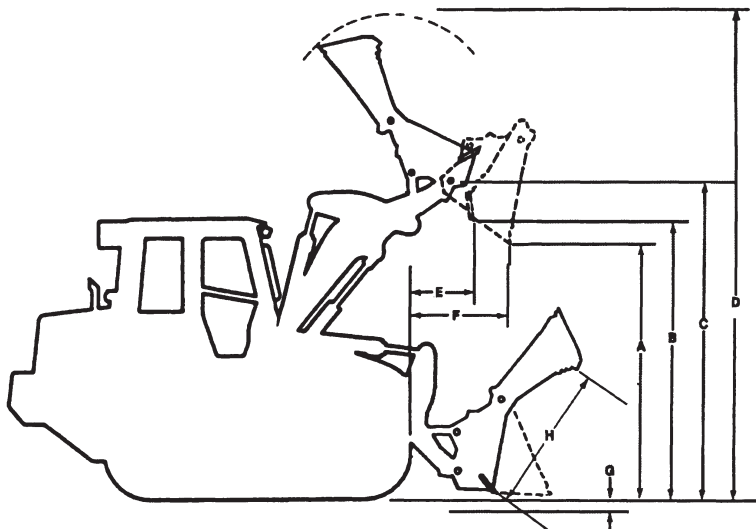

	953D		963D		973D		963K	
A Forward Dump Clearance*	2738 mm	107.7"	3000 mm	118"	3138 mm	123.5"	3000 mm	118"
B Bottom Dump Clearance*	3181 mm	125.2"	3450 mm	135.8"	3670 mm	144"	3450 mm	135.8"
C Hinge Pin Height*	3610 mm	142.1"	3940 mm	155"	4234 mm	166.7"	3940 mm	155"
D Overall Height	4871 mm	192"	5308 mm	209"	5651 mm	222.4"	5308 mm	209"
E Bottom Dump Reach	559 mm	22"	627 mm	24.7"	655 mm	26"	627 mm	24.7"
F Forward Dump Reach*	973 mm	38"	1079 mm	42.5"	—		1079 mm	42.5"
G Digging Depth	142 mm	5.6"	161 mm	6.3"	159 mm	6.26"	161 mm	6.3"
H Bucket Opening	1061 mm	41.7"	1248 mm	49"	—		1248 mm	49"
Reach at 2133 mm (7'0") Height*	1434 mm	56.4"	1598 mm	63"	2327 mm	92"	1598 mm	63"
Tilt Back at Ground Level		42°		45°		45°		45°
Weight of Bucket with Teeth, Segments and Additional Hydraulics	1762 kg	3884.5 lb	2236 kg	4930 lb	3453 kg	7614 lb	2236 kg	4930 lb

*45° Discharge and full lift.
 Operator may prefer to tip bucket forward when bottom dumping.

TRACK LOADER	953D		963D		973D		963K	
Ripper-Scarifier Type	Radial		Radial		Parallelogram		Radial	
Dimensions:								
Ripper Shank								
Maximum Penetration Depth	240 mm	9.45"	330 mm	12.99"	397 mm	15.6"	330 mm	12.99"
Maximum Reach at Ground Line (from track to teeth on ground)	1350 mm	53"	1585 mm	62.4"	1938 mm	76.3"	1585 mm	62.4"
Maximum Ground Clearance under Tip (shank pinned in bottom hole)	552 mm	21.7"	667 mm	26.3"	888 mm	34.9"	667 mm	26.3"
Maximum Ramp Angle, Ripper Up (shank pinned in bottom hole)	18°		17°		28.5°		17°	
Shank Section	50 × 109 mm 2.0" × 4.3"		58.5 × 138 mm 2.3" × 5.4"		74 × 175 mm 2.9" × 6.9"		58.5 × 138 mm 2.3" × 5.4"	
Ripper Beam								
Overall Width	1950 mm	76.8"	1950 mm	76.7"	2200 mm	86.6"	1950 mm	76.7"
Height	165 mm	6.5"	165 mm	6.5"	216 mm	8.5"	165 mm	6.5"
Length	211 mm	8.3"	211 mm	8.3"	254 mm	10"	211 mm	8.3"
Number of Pockets	3		3		3		3	
Pocket Spacing	900 mm	35.4"	896 mm	35.2"	875 mm	34.4"	896 mm	35.2"
Shank Gauge	1800 mm	70.8"	1792 mm	70.5"	1750 mm	68.9"	1792 mm	70.5"
Track Clearance with Standard Shoe	105.2 mm	4.1"	225.3 mm	8.9"	N/A		225.3 mm	8.9"
Installed Weights:								
Ripper with Standard Shank (1 shank)	581 kg	1281 lb	713 kg	1572 lb	1700 kg	3747 lb	713 kg	1572 lb
Each Additional Shank	25 kg	55 lb	36 kg	79 lb	3 shanks std.		36 kg	79 lb
Ripper Forces*								
Penetration Force at Ground Level	50 kN	11,240 lb	64 kN	14,400 lb	100 kN	22,500 lb	64 kN	14,400 lb
Pryout Force at Maximum Digging Depth	116 kN	26,077 lb	151 kN	33,946 lb	242 kN	54,450 lb	151 kN	33,946 lb

*These values may vary slightly with different vehicle configurations.

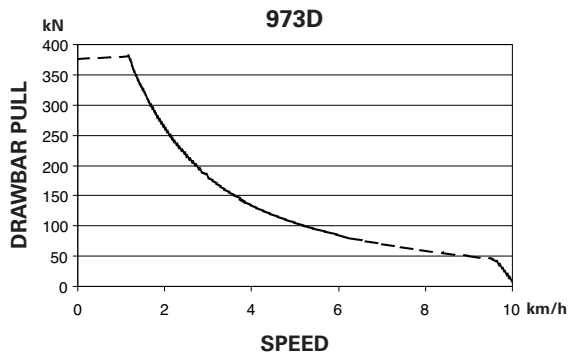
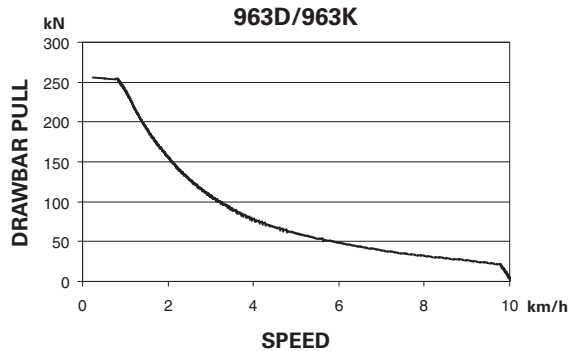
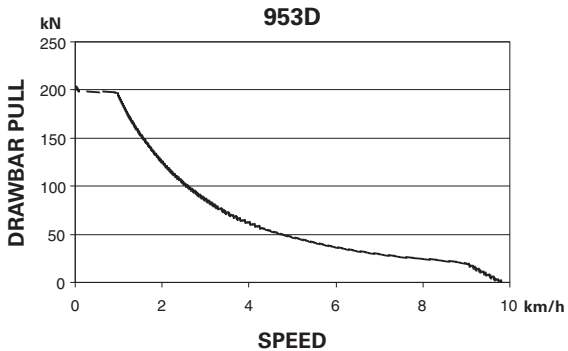

NOTES: Usable pull will depend upon weight and traction of equipped tractor.
 Assumes sufficient machine weight for <5% track slip at POR pressure.
 Assumes pumps and motors are broken in.
 Assumes nominal engine power and valve settings.
 Drawbar pull at track stall will be lower.

EXTREME SLOPE OPERATION

The maximum fore and aft grade in static condition on which each track loader will maintain proper lubrication is 45 degrees (100%). Consult Operation & Maintenance Manual (if applicable) for POWER TRAIN fluid level overfill requirements for operation on extreme slopes. Extreme slope operation is anytime the slope exceeds 25° (47%).

When working sidehills and slopes, consideration should be given to the following important points:

- Speed of travel — At higher speeds, inertia forces tend to make the track loader less stable.
- Roughness of terrain or surface — Ample allowance should be made where the terrain or surface is uneven.
- Mounted equipment — Buckets, rippers, winches, and other mounted equipment cause the track loader to balance differently.
- Nature of surface — New earthen fills may give way with the weight of the track loader. Rocky surfaces may promote side slipping of track loader.

The ENGINE should never be overfilled with oil. This may lead to rapid overheating. For extreme slope operation, engine oil should be maintained at the full mark.

NOTE: Both ENGINE and POWER TRAIN fluid levels should be checked on level ground before working sidehills and slopes.

- Track slippage due to excessive loads — This may cause downhill track to “dig in,” increasing angle of track loader.
- Width of shoes — Wide track shoes tend to decrease “digging in,” hence track loader is more stable.
- Operated equipment — Be aware of the stability and other performance features of the equipment operated by the track loader.
- Keep all attachments or pulled loads low to the ground for optimum stability.

NOTE: Safe operation on steep slopes may require special machine maintenance as well as excellent operator skill and proper equipment for the specific application. Consult Operation & Maintenance Manual (if applicable) for proper fluid level requirements.

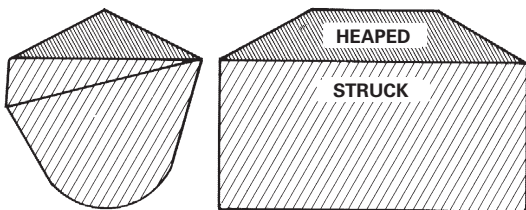
SAE BUCKET RATING**SAE Bucket Capacities**

Struck capacity is that volume contained in a bucket after a load is leveled by drawing a straight edge resting on the cutting edge and the back of the bucket.

Heaped capacity is a struck capacity *plus* that additional material that would heap on the struck load at a 2:1 angle of repose with the struck line parallel to the ground.

SAE J742 (Oct. 79) specifies that the addition of any auxiliary spill guard to protect against spillage of material which might injure the operator will not be included in bucket capacity ratings. Buckets with irregular shaped cutting edges (vee edge) the strike plane should be drawn at one-third the distance of the protruding portion of the cutting edge. Cat rock buckets are built with integral see-through rock guards. Cat light material buckets come standard with bolt-on edges. These features which add to actual bucket capacity are included in published ratings.

Dump Height

SAE J732 JUN92 specifies that dump height is the vertical distance from the ground to the lowest point of the cutting edge with the bucket hinge pin at maximum height and the bucket at a 45° dump angle. Dump angle is the angle in degrees that the longest flat section of the inside bottom of the bucket will rotate below horizontal.

Static Tipping Load

The minimum weight at center of gravity of “SAE Rated” load in bucket which will rotate rear of machine to a point where, on track loaders, front rollers are clear of the track under the following conditions:

- Loader on hard level surface and stationary.
- Unit at standard operating weight.
- Bucket at maximum rollback position.

- Load at maximum forward position during raising cycle.
- Unit with standard equipment as described in specifications unless otherwise noted under the heading.

Operating Load

In order to comply with SAE standard J818 MAY87, the operating load for track loaders should not exceed 35% of the Static Tipping load rating. See “Performance Data” of each machine in this handbook for increases to static tipping load by adding cab, counterweights, ripper-scarifier, etc.

SELECTING A MACHINE**Steps in selecting the proper size loader:**

- Determine production required or desired.
- Determine loader cycle time and cycles per hour. A machine size must be assumed to select a basic cycle time.
- Determine required payload per cycle in loose cubic yards and pounds (meters and kilograms).
- Determine bucket size needed.
- Make machine selection using bucket size and payload as criteria to meet production requirements.
- Compare the loader cycle time used in calculations to the cycle time of the machine selected. If there is a difference, rework the process beginning at step 2.

1. Production Required

The production required of a track loader should be slightly greater than the production capability of the other critical units in the earth or material moving system. For example, if a hopper can handle 300 tons per hour, a loader capable of slightly more than 300 tons should be used. Required production should be carefully calculated so the proper machine and bucket selections are made.

2. Loader Cycle Times

Material type, pile height, and other factors may improve or reduce production, and should be added to or subtracted from the basic cycle time when applicable.

When hauls are involved, obtain haul and return portions of the cycle from the estimated travel chart (this section). Add the haul and return times to the estimated basic cycle time to obtain total cycle time.

CYCLE TIME FACTORS

A basic cycle time (Load, Dump, Maneuver) of 0.25-0.35 minutes is average for a track loader [the basic cycle for large track loaders, 2 m³ (2.6 yd³) and up, can be slightly longer], but variations can be authenticated in the field. The following values for many variable elements are based on normal operations. Adding or subtracting any of the variable times will give the total basic cycle time.

Estimating Cycle Time

Cycle time of a track loader needs to be determined to find loads per hour. Total cycle time includes the following segments:

Load Time + Maneuver Time + Travel Time + Dump Time

Load Time —

Material	Minutes
Uniform aggregates	0.03-0.05
Moist mixed aggregates	0.03-0.06
Moist loam	0.03-0.07
Soil, boulders, roots	0.04-0.20
Cemented materials	0.05-0.20

Maneuver Time — includes basic travel, four changes of direction and turning time, and will be about 0.20 minutes with a competent operator.

Travel Time — in a load and carry operation is comprised of haul and return times which can be determined by the travel charts in this section.

Dump Time — is dictated by the size and strength of the dump target and varies from 0.00 to 0.10 minutes. Typical dump times into highway trucks are from 0.04 to 0.07 minutes.

NOTE: When comparing hydrostatic track loaders with former power shift models (using the production estimating method) two factors must be considered: (1) The hydrostatic track loaders on the average outcycle power shift models by up to 10 percent due to faster machine speed and easier operation. (2) Larger, rear engine hydrostatic track loaders incorporate Z-bar linkage, which provides substantially better bucket fill factors. The degree to which each factor affects estimated production should be left to the user's judgment depending on the particular job application and conditions.

Example: Moist loam is being excavated from a bank and loaded into trucks.

	Minutes
Load — moist loam	0.05
Maneuver Time	0.20
Travel — none required	0.00
Dump	0.05
Total Cycle	0.30 min. or 200 cycles per 60 min. hour

*Minutes added (+)
or Subtracted (-)
From Basic Cycle*

Materials

- Mixed +0.02
- Up to 3 mm (1/8 in) +0.02
- 3 mm (1/8 in) to
20 mm (3/4 in) -0.02
- 20 mm (3/4 in) to
150 mm (6 in) 0.00
- 150 mm (6 in) and over +0.03 and Up
- Bank or broken +0.04 and Up

Pile

- Conveyor or Dozer piled
3 m (10 ft) and up 0.00
- Conveyor or Dozer piled
3 m (10 ft) or less +0.01
- Dumped by truck +0.02

Miscellaneous

- Common ownership of
trucks and loaders Up to -0.04
- Independently owned trucks Up to +0.04
- Constant operation Up to -0.04
- Inconsistent operation Up to +0.04
- Small target Up to +0.04
- Fragile target Up to +0.05

Using actual job conditions and the above factors, total cycle time can be estimated. Convert total cycle time to cycles per hour.

$$\text{Cycles per hour at 100\% Efficiency} = \frac{60 \text{ Min}}{\text{Total Cycle Time in Minutes}}$$

Job efficiency is an important factor in machine selection. Efficiency is the actual number of minutes worked during an hour. Job efficiency accounts for operator breaks, and other work interruptions. See "Efficiency Considerations" in this section.

- Bucket Fill Factors
 - Recommended Operating Capacities
- ## Loader Production

Bucket Fill Factors

The following indicates the approximate amounts of material as a percent of rated bucket capacity which will actually be delivered per bucket per cycle. This is known as “Bucket Fill Factor.”

Loose Material	Fill Factor
Mixed Moist Aggregates	95-110%
Uniform Aggregates up to 3 mm (1/8 in)	95-110
3 mm-9 mm (1/8 in-3/8 in)	90-110
12 mm-20 mm (1/2 in-3/4 in)	90-110
24 mm and over (1 in)	90-110
Blasted Rock	
Well	80-95%
Average	75-90
Poor	60-75
Other	
Rock Dirt Mixtures	100-120%
Moist Loam	100-120
Soil, Boulders, Roots	80-100
Cemented Materials	85-100

Fill factors on track loaders are affected by bucket penetration, breakout force, rack back angle, bucket profile and ground engaging tools such as bucket teeth and segments or bolt-on replaceable cutting edges.

GENERAL PURPOSE BUCKET W/TEETH & SEGMENTS MAXIMUM OPERATING CAPACITIES

MODEL	GENERAL PURPOSE BUCKET SIZE		MAXIMUM OPERATING CAPACITY	
	m ³	yd ³	kg	lb
953D	1.85	2.4	3182	7015
963D/963K	2.45	3.2	4214	9290
973D	3.21	4.2	5521	12,174

LOADER PRODUCTION

Loader production equals quantity of material the bucket carries per load × number of bucket loads per hour.

Estimating Bucket Load

The quantity of material in a loader bucket is estimated by two methods, depending on whether the material being loaded is in a loose or bank state.

1. When the material is loose, as in stockpile loading, the bucket load is estimated in loose meters (or cubic yards) by a Bucket Fill Factor (see Tables Section or chart following this discussion). The quantity of material is determined as follows:

$$\text{Rated Bucket Capacity} \times \text{Bucket Fill Factor} = \text{Bucket Payload in Loose m}^3 \text{ (yd}^3\text{)}$$

For example, a 973 with a 3.2 m³ (4.2 yd³) General Purpose bucket loading moist loam material will carry:

$$3.2 \text{ m}^3 \times 1.15 = 3.68 \text{ loose cubic meters}$$

$$(4.2 \text{ yd}^3 \times 1.15 = 4.83 \text{ loose cubic yards})$$

Once the potential bucket load has been determined, check the static tipping load ratings on the specific machine to determine if bucket load is in fact a safe operating load. (*Safe operating load as defined by SAE for track loaders should not exceed 35% of static tipping load.*)

Productivity in many applications is measured in tons. See Tables Section for material densities if conversion to tons is desired.

2. When material is in the bank state, as in excavation, productivity is measured in bank meters (cubic yards). Bucket load in Bm³ (BCY) is estimated by applying one of the load factors from the Tables section to convert the excavated material in the bucket from Bm³ (BCY) to Lm³ (LCY) to allow for the digging and carrying characteristics of the material. The quantity of excavated material a bucket carries is then determined as follows:

$$\text{Rated Bucket Capacity} \times \text{Load Factor} \times \text{Bucket Fill Factor} = \text{Bucket Payload in Bm}^3 \text{ (BCY)}$$

Example: a 953D with a 1.85 m³ (2.4 yd³) General Purpose bucket loading wet loam earth from bank:

$$1.85 \text{ m}^3 \times 0.79 \times 1.15 = 1.68 \text{ Bm}^3$$

$$(2.4 \text{ yd}^3 \times 0.79 \times 1.15 = 2.18 \text{ BCY})$$

Estimating Production

Machine and job considerations include:

- Machine model and bucket size
- Material type, particle size, density and load factor (see Tables Section)
- Bucket fill factor
- Haul distance
- Underfoot conditions
- Altitude
- Dump target size, height, and type

Example:

Conditions —

Machine	953D
Bucket size	1.85 m ³ (2.4 yd ³)
Material	Moist Loam
Bucket fill factor	1.15
Haul length	30 m (100 ft)
Dump target	Pile
Travel in forward speed	

Cycle Time

	Minutes
Load time	0.15
Maneuver time	0.20
Travel time (from curves)	0.40
Dump time	0.05
Total	0.80

Loads Per Hour —

$$\frac{60 \text{ min/hr}}{0.80 \text{ min/cycle}} = 75 \text{ cycles per hour @ } 100\% \text{ efficiency}$$

Load Per Cycle —

$$\begin{aligned}
 1.85 \text{ m}^3 \times 1.15 \text{ BFF} &= 2.13 \text{ Lm}^3 \times 0.81 \text{ LF} \\
 &= 1.72 \text{ Bm}^3 \\
 (2.4 \text{ yd}^3 \times 1.15 \text{ BFF} &= 2.76 \text{ LCY} \times 0.81 \text{ LF} \\
 &= 2.24 \text{ BCY})
 \end{aligned}$$

Hourly Production —

$$\begin{aligned}
 1.72 \text{ Bm}^3 \times 75 \text{ cycles/h} &= 129 \text{ Bm}^3/\text{h} \\
 (2.24 \text{ BCY} \times 75 \text{ cycles/hr} &= 168 \text{ BCY/hr})
 \end{aligned}$$

More accurate production estimates can be made by recording actual machine cycle times in the same or similar application. Then visually verify the approximate bucket fill factor.

Efficiency Considerations

Loader capacity should always be matched to peak production requirements of the job. Actual “on-the-job” loader productivity will be influenced by factors such as operator skill, personal delays, job layout and other delays. Experience and knowledge of local conditions will be the best indicators of actual job efficiency.

Operation	Working Hour	Efficiency Factor
Day	50 min/Hr	0.83

An Alternative Machine Selection Method

Another method of selecting the right Track Loader and bucket to meet production requirements is by use of the nomographs on the following pages. The method is quicker and easier than the preceding example because it does not require as many calculations, yet the accuracy is about the same within the normal limits of input data.

Be careful when entering and reading data from the nomographs because some scales increase from bottom to top, while others are the reverse. Do not be overly concerned with the precision as affected by pencil line width or reading to the hundredth of a m³ (yd³). Remember that bucket fill factor, material density, and cycle time are at best close estimates.

Example problem

A track loader must produce 200 Lm³ (262 LCY) per hour. Estimated cycle time is 0.5 minutes, working 50 minutes per hour. Bucket fill factor is 110% and the material density is 1600 kg/Lm³ (2700 lb/LCY).

Determine bucket size, machine model and hourly production in tons and yards.

Solution

At full efficiency, it will cycle 120 times per hour. Since only an average 50 minutes are available, only 100 cycles will be completed per hour.

Starting on Scale A at 100 cycles per hour draw a straight line intersecting 200 m³/hr (262 yd³/hr) on Scale B and continuing the line on to Scale C giving 2.0 m³ (2.62 yd³) required payload.

Follow steps 1 through 7 on the next two pages.



Track Loaders

Production and Machine Selection Nomograph

- To find required bucket payload and bucket size

- 1) Enter Scale A cycles per hour (100) and B hourly production 200 m³/hr (262 yd³/hr).
- 2) Connect A and B and extend to C to find required payload 2.0 m³ (2.62 yd³).
- 3) Connect C to bucket fill factor on Scale D (110%) and extend to E to find required bucket size 1.8 m³ (2.35 yd³).
- 4) Transfer Scale A and C readings to nomograph on following page.

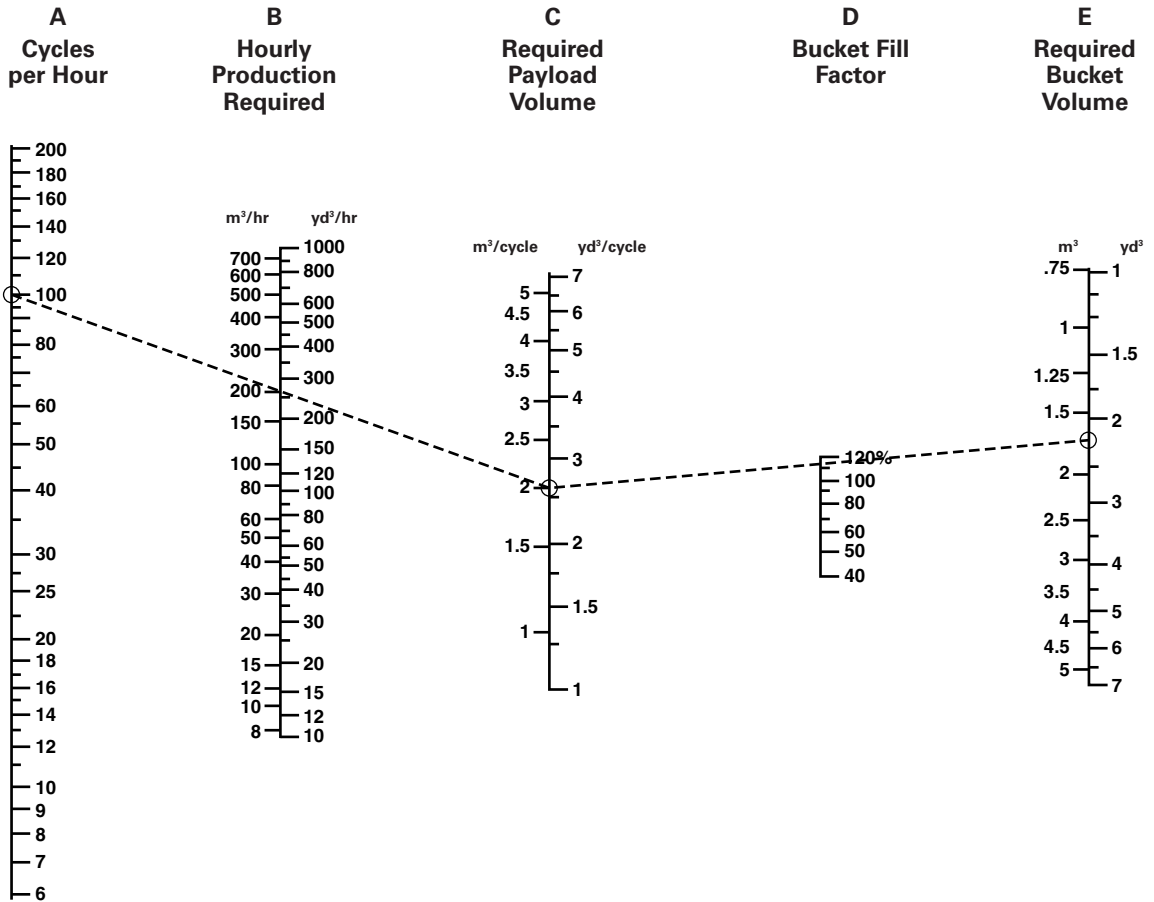

Production and Machine Selection Nomograph

Track Loaders

- To find payload weight for stability and output in tons per hour

- 5) Connect C 1.8 m³ (2.35 yd³) to F 1600 kg/m³ (2700 lb/yd³) and extend to G to find payload weight 2880 kg (6345 lb).
- 6) Compare G bucket payload weight 2880 kg (6345 lb) with maximum operating capacities table in this section to see if the 1.85 m³ (2.4 yd³) bucket can handle the desired payload. Table indicates the 953D with a

- 1.85 m³ (2.4 yd³) bucket equipped with bolt-on cutting edge or teeth and segments has a greater operating capacity of 3343 kg (7370 lb), therefore stability is okay.
- 7) Extend Scale G reading 2880 kg (6345 lb) through Scale A (100) to Scale I to find tons per hour 288 metric ton/hr (317 U.S. ton/hr).

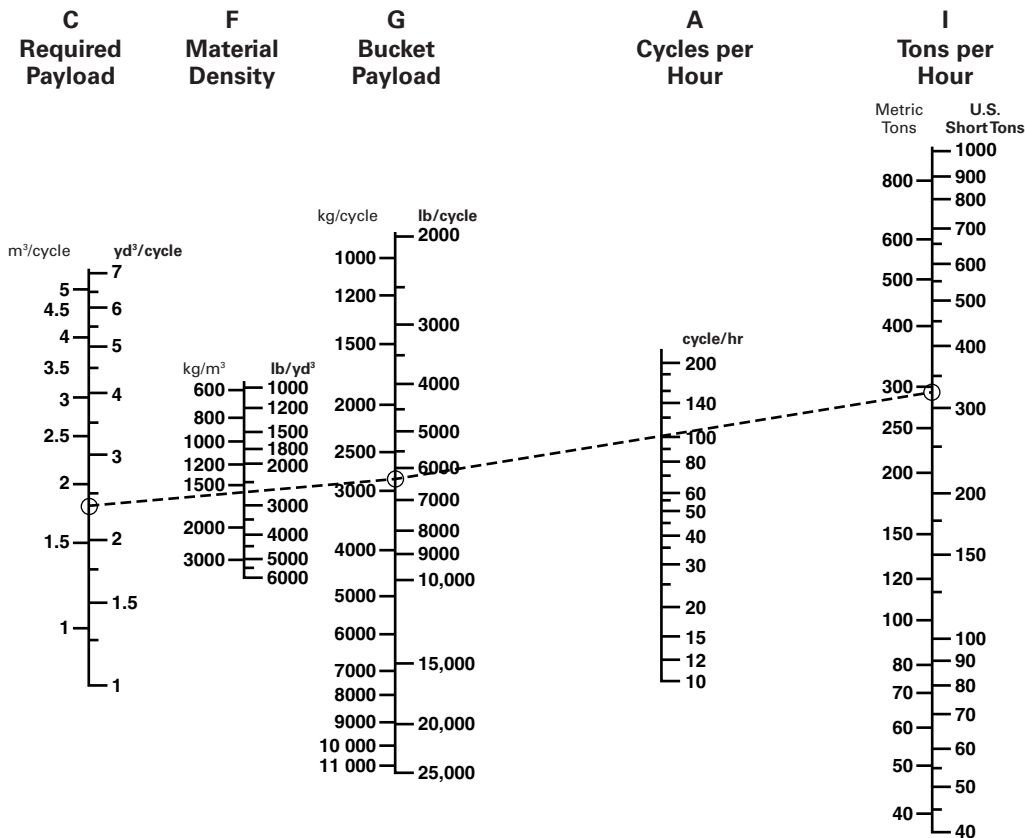

953D

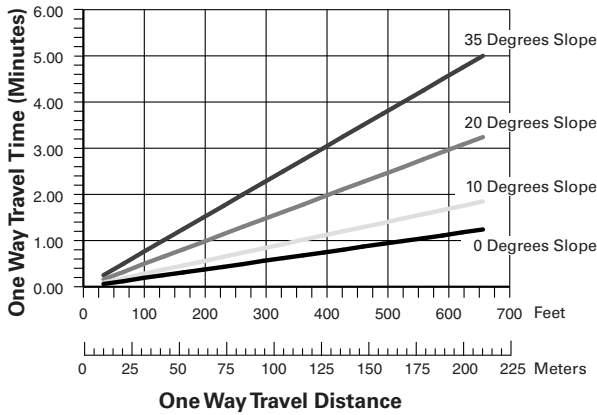

963D/963K

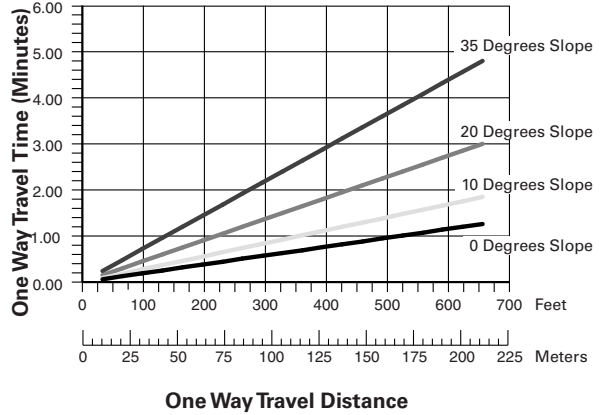

973D

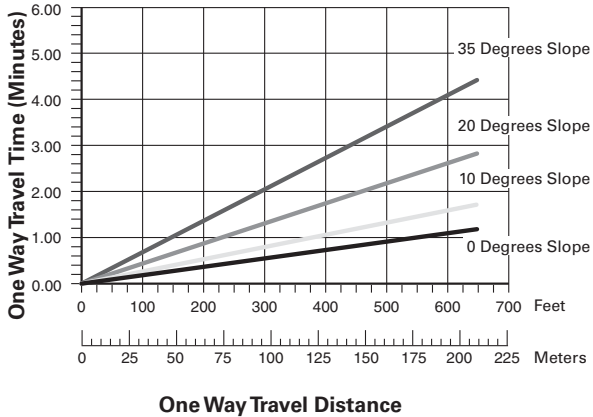

TRAVEL TIME CHARTS

Conditions:

- No grades.
- Speeds loaded and empty essentially the same.
- Bucket position constant during travel.
- Travel encountered in maneuver portion of cycle not included.
- Acceleration time accounted for in maneuver time.

Travel Time (in minutes) =

$$Metric = \frac{\text{number of meters traveled}}{\text{speed (in km/h)} \times 16.67}$$

$$English = \frac{\text{number of feet traveled}}{\text{speed (in mph)} \times 88}$$

KEY

- 953D — Hydrostatic top speed both forward and reverse 10 km/h (6.2 mph)
- 963D — Hydrostatic top speed both forward and reverse 10 km/h (6.2 mph)
- 973D — Hydrostatic top speed both forward and reverse 11 km/h (6.83 mph)

Production Estimating Table
 ● m³ or yd³/60 min. hour
 ● Estimated bucket payload in
 bank m³ or yd³

Track Loaders

Bucket Size (m ³ or yd ³)		1.0	1.5	2.0	2.5	3.0	3.5	4.0	4.5	5.0
Cycle Time Hundredths of a minute	Cycles Per Hr	Unshaded area indicates average work range								
		0.25	240	240	360	480	600	720	840	960
0.30	200	200	300	400	500	600	700	800		
0.35	171	171	257	342	428	513	599	684	769	
0.40	150	150	225	300	375	450	525	600	675	750
0.45	133	133	200	268	332	400	466	530	600	665
0.50	120	120	180	240	300	360	420	480	540	600
0.55	109	109	164	218	272	328	382	436	490	545
0.60	100	100	150	200	250	300	350	400	450	600
0.65	92	92	138	184	230	276	322	368	416	460

Work Tools	953D	963D/963K	973D
Fusion™ Coupler		X	
Quick Coupler	X	X	X
Fusion General Purpose Bucket		X	
General Purpose (GP) bucket	X	X	X
GP bucket with trash rack	X	X	X
MP bucket with trash rack	X	X	X
Landfill bucket	X	X	X
Landfill Multi-purpose	X	X	X
Multi-purpose (MP) bucket	X	X	X
Trim blade	X	X	X
Slag bucket			X
Fusion Pallet Forks		X	
Forks (for QC or bucket)	X	X	X
Material handling arm	X	X	X
Loader rake	X	X	X
Top-Clamp bucket	X		X
Side Dump bucket	X	X	X

New Fusion Coupler System for 963D/963K Track Loaders

The proven Fusion Coupler System is available for 963D/963K machines. Key durability benefits experienced with the wheel loader platform are now available for the 963D/963K Track Loader.

The biggest gain for the track loader user is durability; the Fusion coupler endures like no other. Patented dual wedge locks pull the tool tight to the coupler and hold it there for a solid, rattle-free fit. No rattle means no wear, so tools last longer. The wedge lock is built to stay tight even after thousands of tool changes. This coupler is built to be as tough as the linkage itself, for trouble-free performance day in and day out.

The 963D/963K Fusion Coupler is supported by a set of tools:



General Purpose Buckets provide good all-around performance for stockpiling, re-handling, excavating and bank loading. A wide bucket is available for use with a machine that has wide gauge tracks.



Multi-Purpose Buckets have a unique four-way action that can load, strip top soil, bulldoze, clamp pipe or large chunks of concrete, clean up debris and many other tasks.



Pallet Forks are an essential tool on construction job sites. Cat Fusion Pallet Forks can be configured to allow the tines to either swing or stay in a fixed position.

Fusion Interchangeability

The Fusion Coupler for the 963D/963K is compatible with most of the Fusion tools for wheel loaders, allowing interchangeability. However, common sense must be used as machine power envelopes and use profiles are very different for each machine platform.

Care must be taken to get the best performance while taking advantage of tool interchangeability. While all Fusion couplers can pick up any Fusion tool, some tools are less useful when used on a different type of carrier than their design intent.

For compatibility questions, contact Cat Work Tools.

SHOE OPTIONS



① Double Grouser Shoes

- **Extreme service shoes** are available which have more hardened wear material for longer wear life and higher impact applications.



② Trapezoidal Center Hole Shoes



③ Single Grouser Shoes



④ Chopper Shoes

- **Wider shoes** are also available to reduce ground pressure in soft underfoot conditions.

Other shoe options are available. Consult a Cat dealer for more information.

SYSTEMONE SHOES



Double Grouser Shoes

- Work best in applications that require less penetration and traction.
- Recommended for applications that require better turning capability and less ground disturbance.
- Feature two or three short grousers instead of one tall grouser.



Center Hole Shoes

- Work best in applications where packing causes the track to tighten. They are recommended for applications with large amounts of debris what tend to pack in the track.
- Reduces extricable packing between the shoe and the bushing since they allow the sprocket to punch out dirt and debris.

TRACK-TYPE TRACTORS

Hydraulic Controls

Bulldozers

Rippers and Winches

CONTENTS

TRACK-TYPE TRACTORS

Features	19-1
Specifications	19-3
Power Shift Drawbar Pull vs. Ground Speed Curves	19-18
Power Shift Travel Speeds	19-24
Ground Pressures	19-26
Extreme Slope Operation	19-28

HYDRAULIC CONTROLS

Features	19-29
Specifications	19-30

BULLDOZERS

Features	19-33
Summary of Blade Options	19-34
Blade Selection	19-36
General Dimensions (Tractor and Blade)	19-39
SAE Blade Capacity Definition	19-39
Blade Specifications	19-40
Estimating Production Off-the-Job	19-50
Job Condition Correction Factors	19-55
Measuring Production On-the-Job	19-56
Attachments	19-56
Special Attachments	19-57

RIPPERS

Features	19-59
Ripper Specification Diagrams	
Adjustable Parallelogram Ripper	19-60
Radial Ripper	19-62
Fixed Parallelogram Ripper	19-62
Specifications	
Track-Type Tractors	19-63
Tip Selection	19-73
Estimating Ripping Production	19-73
Seismic Wave Velocity Charts	19-76
Estimated Ripper Production Graphs	19-81

WINCHES

PACCAR

Features	19-84
Physical Specifications	19-85
Operating Specifications	19-95

Allied

Features	19-99
Physical Specifications	19-100
Operating Specifications	19-107

TRACK-TYPE TRACTORS

Features:

- **Cat® Diesel Engines** provide the power, high torque rise, reliability and performance you can depend on.
- **HEUI™** on D6R and D7R increases fuel efficiency, reduces smoke, improves cold starting and enhances diagnostic capabilities.
- **Mechanical Electronic Unit Injector (MEUI™)** on D8T, D9T, D10T2 and D11T excels in its ability to control injection pressure over the entire engine operating speed range. It combines the technical advancement of an electronic control system with the simplicity of direct mechanically controlled unit fuel injection. These features allow the engine to have complete control over injection timing, duration, and pressure.
- **Common Rail fuel injection system** on D3K2, D4K2, D5K2, D6K2, D5R2, D6T and D7E machines; optimizes performance and fuel consumption, minimizes heat rejection, and lowers emissions.

- **Oil cooled steering clutches and brakes** standard on D9R, D10T2 and D11T.
- **Finger Tip Controls (FTC)** of transmission, steering clutches and brakes on D10T2 and D11T.
- **Differential steering** allows infinitely variable turning radius. Standard on the D5R2, D6R2, D6T, D7R, D7E, D8R, D8T and D9T, allows the tractor to make a “power turn” keeping both tracks working for more traction and higher performance.
- **Electronic Hydrostatic Power Train System** on D3K2 through D6K2 allows power turns, stepless speed range, smooth modulation, dynamic hydrostatic braking, superior maneuverability and excellent controllability.
- **Electric Drive Power Train System** on D7E allows stepless speed range, smooth modulation, and excellent efficiency. When coupled with differential steer it provides superior maneuverability with locked-track pivot turn capability and excellent controllability.
- **Combined hand lever steering** located left of operator provides easier operation on D9R.
- **Standard Tractors** designed for heavy dozing and general grading.
- **XL Tractor D6T** offers higher horsepower and longer roller frames for increased finish grading capability, flotation and productivity.
- **Extra Wide (XW) gauge** on D6T length roller frame provides wider shoes for greater flotation and stability for steep slope grading.
- **Sealed and Lubricated Track** reduces pin and bushing wear for lower undercarriage repair costs. Sealed and lubricated track is standard on the D3K2, D4K2, and D5K2 while heavy duty track chain is available on D5R, D6K2, D6N, D6T, and D7E improves wear life and reduces pin/bore stretching and cracking.
- **SystemOne™ Undercarriage** extends undercarriage system life, improves reliability, and reduces owning and operating costs. Optional on D6T (all sources), D5R2, D6K2, D6N, D6R2, optional on D8T and D8R (all sources), D3K2, D4K2, D5K2.
- **Elevated sprockets** (not on D6K2 or D7E) eliminate final drive stress induced by roller frame movement and ground impact loads. Final drives pull chain only. Seals moved up out of dirt, sand and water for longer life. Blade visibility improved because operator sits higher.
- **Resilient mounted bogie undercarriage** on D8R, D8T, D9T, D10T2 and D11T reduces shock transmitted to tractor. Allows track to conform to rough ground for better traction.
- **Solid mounted undercarriage** standard on D3K2 through D5K2 provides stable platform for low impact, and high abrasion applications. Provides optimum finish grading performance.
- **Oscillating undercarriage** on D6K2 through D7E and optional on the D8R and D8T decreases ground shock to the machine and provides a smoother, more comfortable ride for the operator.
- **Accessible modular design** on D6N XL and up greatly reduces drive train removal and installation time resulting in reduced repair costs.
- **Tag link** on D7R, D8R/D8T and up; L-shaped push arms on D6N, D6T and D7E. Both designs allow closer mounting of dozer blades. This reduces total tractor length, improves maneuverability, balance, blade penetration and pryout.
- **Low ground pressure (LGP)** tractors offer greater flotation in soft, swampy conditions. Available on D3K2 through D8T.

MODEL	D3K2 XL		D3K2 LGP		D3K2 XL		D3K2 LGP	
Emission Standards	U.S. EPA Tier 3/ EU Stage IIIA/ Japan 2006 (Tier 3) equivalent ¹		Tier 3/Stage IIIA/ Japan 2006 (Tier 3) equivalent ¹		Tier 4 Final/Stage IV/ Japan 2014 (Tier 4 Final)		Tier 4 Final/Stage IV/ Japan 2014 (Tier 4 Final)	
Flywheel Power	55.2 kW	74 hp	55.2 kW	74 hp	59.7 kW	80 hp	59.7 kW	80 hp
Operating Weight ²	7795 kg	17,185 lb	8093 kg	17,842 lb	7958 kg	17,544 lb	8403 kg	18,525 lb
Engine Model	C4.4 ACERT™		C4.4 ACERT		C4.4 ACERT		C4.4 ACERT	
Rated Engine RPM	1900		1900		2200		2200	
No. of Cylinders	4		4		4		4	
Bore	105 mm	4.13"	105 mm	4.13"	105 mm	4.13"	105 mm	4.13"
Stroke	127 mm	5.0"	127 mm	5.0"	127 mm	5.0"	127 mm	5.0"
Displacement	4.4 L	269 in³	4.4 L	269 in³	4.4 L	269 in³	4.4 L	269 in³
Track Rollers (Each Side)	6		6		6		6	
Width of Standard Track Shoe	406 mm	16"	635 mm	25"	406 mm	16"	635 mm	25"
Length of Track on Ground	2095 mm	83"	2095 mm	83"	2248 mm	89"	2248 mm	89"
Ground Contact Area (w/Std. Shoe)	17 011 cm ²	2637 in²	26 607 cm ²	4124 in²	18 254 cm ²	2848 in²	28 550 cm ²	4425 in²
Track Gauge	1495 mm	59"	1725 mm	68"	1495 mm	59"	1725 mm	68"
GENERAL DIMENSIONS:								
Height (To Top of ROPS)	2763 mm	108.8"	2763 mm	108.8"	2763 mm	108.8"	2763 mm	108.8"
Overall Length (with P blade)	4266 mm	168"	4255 mm	167.6"	4266 mm	168"	4266 mm	168"
(without Blade)	3275 mm	128.9"	3275 mm	128.9"	3275 mm	128.9"	3275 mm	128.9"
Width (w/o Trunnion and Blade — Std. Shoe)	1901 mm	74.8"	2360 mm	92.9"	1901 mm	74.8"	2360 mm	92.9"
Ground Clearance	332 mm	13"	332 mm	13"	332 mm	13"	332 mm	13"
Blade Types and Widths:								
VPAT, Straight	2646 mm	104.1"	3149 mm	124.0"	2646 mm	104.1"	3149 mm	124"
VPAT, Angled 25°	2417 mm	95.1"	2874 mm	113"	2417 mm	95.1"	2874 mm	113"
Fuel Tank Refill Capacity	195 L	51.5 U.S. gal	195 L	51.5 U.S. gal	195 L	51.5 U.S. gal	195 L	51.5 U.S. gal

¹ Meets Tier 3/Stage IIIA/Japan 2006 (Tier 3) equivalent emission standards.

² Operating weight includes ROPS canopy, operator, lubricants, coolant, full fuel tank, hydraulic controls and fluids, back-up alarm, seat belts, lights, rigid drawbar, front pull device and standard service crankcase guard.

MODEL	D4K2 XL		D4K2 LGP		D4K2 XL		D4K2 LGP	
Emission Standards	Tier 3/Stage IIIA/ Japan 2006 (Tier 3) equivalent ¹		Tier 3/Stage IIIA/ Japan 2006 (Tier 3) equivalent ¹		Tier 4 Final/Stage IV/ Japan 2014 (Tier 4 Final)		Tier 4 Final/Stage IV/ Japan 2014 (Tier 4 Final)	
Flywheel Power	62.6 kW	84 hp	62.6 kW	84 hp	68.8 kW	92 hp	68.8 kW	92 hp
Operating Weight ²	8147 kg	17,961 lb	8501 kg	18,742 lb	8201 kg	18,080 lb	8510 kg	18,761 lb
Engine Model	C4.4 ACERT		C4.4 ACERT		C4.4 ACERT		C4.4 ACERT	
Rated Engine RPM	1900		1900		2200		2200	
No. of Cylinders	4		4		4		4	
Bore	105 mm	4.13"	105 mm	4.13"	105 mm	4.13"	105 mm	4.13"
Stroke	127 mm	5.0"	127 mm	5.0"	127 mm	5.0"	127 mm	5.0"
Displacement	4.4 L	269 in³	4.4 L	269 in³	4.4 L	269 in³	4.4 L	269 in³
Track Rollers (Each Side)	7		7		7		7	
Width of Standard Track Shoe	460 mm	18"	635 mm	25"	460 mm	18"	635 mm	25"
Length of Track on Ground	2248 mm	89"	2248 mm	89"	2248 mm	89"	2248	89"
Ground Contact Area (w/Std. Shoe)	20 682 cm ²	3206 in²	28 550 cm ²	4425 in²	20 862 cm ²	3206 in²	28 550 cm ²	4425 in²
Track Gauge	1550 mm	61"	1725 mm	68"	1550 mm	61"	1725 mm	68"
GENERAL DIMENSIONS:								
Height (To Top of ROPS)	2763 mm	108.8"	2763 mm	108.8"	2763 mm	108.8"	2763 mm	108.8"
Overall Length (with P blade)	4274 mm	168"	4266 mm	168"	4266 mm	168"	4266 mm	168"
(without Blade)	3275 mm	128.9"	3275 mm	128.9"	3275 mm	128.9"	3275 mm	128.9"
Width (w/o Trunnion and Blade – Std. Shoe)	2010 mm	79.1"	2360 mm	92.9"	2010 mm	79.1"	2360 mm	92.9"
Ground Clearance	332 mm	13"	332 mm	13"	332 mm	13"	332 mm	13"
Blade Types and Widths:								
VPAT, Straight	2782 mm	109.5"	3149 mm	124.0"	2782 mm	109.5"	3149 mm	124"
VPAT, Angled 25°	2542 mm	100.1"	2874 mm	113"	2542 mm	100.1"	2874 mm	113"
Fuel Tank Refill Capacity	195 L	51.5 U.S. gal	195 L	51.5 U.S. gal	195 L	51.5 U.S. gal	195 L	51.5 U.S. gal

¹ Meets Tier 3/Stage IIIA/Japan 2006 (Tier 3) equivalent emission standards.

² Operating weight includes ROPS canopy, operator, lubricants, coolant, full fuel tank, hydraulic controls and fluids, back-up alarm, seat belts, lights, rigid drawbar, front pull device and standard service crankcase guard.

MODEL	D5K2 XL		D5K2 LGP		D5K2 XL		D5K2 LGP	
Emission Standards	Tier 3/Stage IIIA/ Japan 2006 (Tier 3) equivalent ¹		Tier 3/Stage IIIA/ Japan 2006 (Tier 3) equivalent ¹		Tier 4 Final/Stage IV/ Japan 2014 (Tier 4 Final)		Tier 4 Final/Stage IV/ Japan 2014 (Tier 4 Final)	
Flywheel Power:								
Hydrostatic	71.6 kW	96 hp	71.6 kW	96 hp	77.6 kW	104 hp	77.6 kW	104 hp
Operating Weight: ²								
Hydrostatic	9408 kg	20,741 lb	9683 kg	21,347 lb	9314 kg	20,534 lb	9646 kg	21,266 lb
Engine Model	C4.4 ACERT		C4.4 ACERT		C4.4 ACERT		C4.4 ACERT	
Rated Engine RPM	1900		1900		2100		2100	
No. of Cylinders	4		4		4		4	
Bore	105 mm	4.13"	105 mm	4.13"	105 mm	4.13"	105 mm	4.13"
Stroke	127 mm	5.0"	127 mm	5.0"	127 mm	5.0"	127 mm	5.0"
Displacement	4.4 L	269 in³	4.4 L	269 in³	4.4 L	269 in³	4.4 L	269 in³
Track Rollers (Each Side)	7		7		7		7	
Width of Standard Track Shoe	510 mm	20"	660 mm	26"	510 mm	20"	660 mm	26"
Length of Track on Ground	2310 mm	91"	2310 mm	91"	2310 mm	91"	2310 mm	91"
Ground Contact Area (w/Std. Shoe)	23 562 cm ²	3652 in²	30 492 cm ²	4726 in²	23 562 cm ²	3652 in²	30 492 cm ²	4726 in²
Track Gauge	1600 mm	63"	1750 mm	69"	1600 mm	63"	1750 mm	69"
GENERAL DIMENSIONS:								
Height (To Top of ROPS Canopy)	2769 mm	109.0"	2769 mm	109.0"	2769 mm	109.0"	2769 mm	109.0"
Height (To Top of ROPS Cab)	2769 mm	109.0"	2769 mm	109.0"	2769 mm	109.0"	2769 mm	109.0"
Overall Length (with P Blade)	4321 mm	170.1"	4294 mm	169.1"	4321 mm	170.1"	4321 mm	170.1"
(without Blade)	3199 mm	125.9"	3265 mm	128.5"	3199 mm	125.9"	3265 mm	128.5"
Width (w/o Trunnion and Blade – Std. Shoe)	2110 mm	83.1"	2410 mm	94.9"	2110 mm	83.1"	2410 mm	94.9"
Ground Clearance	332 mm	13"	332 mm	13"	332 mm	13"	332 mm	13"
Blade Types and Widths:								
VPAT, Straight	2782 mm	109.5"	3220 mm	126.7"	2782 mm	109.5"	3220 mm	126.7"
VPAT, Angled 25°	2636 mm	103.8"	2940 mm	115.8"	2636 mm	103.8"	2940 mm	115.8"
Fuel Tank Refill Capacity	195 L	51.5 U.S. gal	195 L	51.5 U.S. gal	195 L	51.5 U.S. gal	195 L	51.5 U.S. gal

¹ Meets Tier 3/Stage IIIA/Japan 2006 (Tier 3) equivalent emission standards.

² Operating weight includes ROPS canopy, operator, lubricants, coolant, full fuel tank, hydraulic controls and fluids, back-up alarm, seat belts, lights, rigid drawbar, front pull device and standard service crankcase guard.

MODEL	D5R2 XL		D5R2 LGP		D5T XL	
Emission Standards	Tier 3/Stage IIIA/ Japan 2006 (Tier 3) equivalent		Tier 3/Stage IIIA/ Japan 2006 (Tier 3) equivalent		Tier 3/Stage IIIA/ Japan 2006 (Tier 3) equivalent	
Flywheel Power	112 kW	150 hp	112 kW	150 hp	112 kW	150 hp
Operating Weight:						
Power Shift Differential Steer	16 672 kg	36,755 lb	18 584 kg	40,971 lb	16 672 kg	36,755 lb
Engine Model	C7.1 ACERT		C7.1 ACERT		C7.1 ACERT	
Rated Engine RPM	2200		2200		2200	
No. of Cylinders	6		6		6	
Bore	105 mm	4.13"	105 mm	4.13"	105 mm	4.13"
Stroke	135 mm	5.3"	135 mm	5.3"	135 mm	5.3"
Displacement	7.01 L	427.8 in ³	7.01 L	427.8 in ³	7.01 L	427.8 in ³
Track Rollers (Each Side)	7		8		7	
Width of Standard Track Shoe	610 mm	24"	840 mm	33.1"	610 mm	24"
Length of Track on Ground	2611 mm	103"	3113 mm	122.6"	2611 mm	103"
Ground Contact Area (w/Std. Shoe)	3.18 m ²	4929 in ²	5.23 m ²	8107 in ²	3.18 m ²	4929 in ²
Track Gauge	1890 mm	74.4"	2160 mm	85"	1890 mm	74.4"
GENERAL DIMENSIONS:						
Height (To Top of ROPS Cab/Canopy)	3086 mm	121.5"	3200 mm	126.0"	3086 mm	121.5"
Length of Basic Tractor (w/o Blade) with following attachments, add:	3480 mm	137.0"	4017 mm	158.1"	3480 mm	137.0"
SU Blade	1546 mm	60.9"	—	—	1546 mm	60.9"
A Blade (when Straight)	1450 mm	57.1"	—	—	—	—
A Blade (when Angled 25°)	2303 mm	90.7"	—	—	—	—
VPAT Blade (when Straight)	1343 mm	52.9"	1249 mm	49.2"	1343 mm	52.9"
VPAT Blade (when Angled 25°)	1965 mm	77.4"	2004 mm	78.9"	1965 mm	77.4"
Rear Drawbar	192 mm	7.6"	148 mm	5.8"	192 mm	7.6"
Multi-Shank Ripper (tip at ground level)	1230 mm	48.4"	1190 mm	46.9"	1230 mm	48.4"
Width of Tractor:	2500 mm	98.4"	3000 mm	118"	2500 mm	98.4"
Over Trunnion	2640 mm	103.9"	3279 mm	129.1"	2640 mm	103.9"
Without Trunnion (standard shoe width)	2490 mm	98.0"	3000 mm	118.1"	2490 mm	98.0"
Ground Clearance	394 mm	15.5"	507 mm	20.0"	394 mm	15.5"
Blade Types and Widths:						
SU Blade	3154 mm	124.2"	—	—	3154 mm	124.2"
A Blade	4165 mm	164.0"	—	—	—	—
VPAT Blade — XL	3272 mm	128.8"	—	—	3272 mm	128.8"
VPAT Blade — LGP	—	—	4080 mm	160.6"	—	—
Fuel Tank Refill Capacity	299 L	79.3 U.S. gal	299 L	79.3 U.S. gal	299 L	79.3 U.S. gal

MODEL	D6K2 XL		D6K2 LGP		D6K2 XL		D6K2 LGP	
Emission Standards	Tier 3/Stage IIIA/ Japan 2006 (Tier 3) equivalent		Tier 3/Stage IIIA/ Japan 2006 (Tier 3) equivalent		Tier 4 Final/Stage IV/ Japan 2014 (Tier 4 Final)		Tier 4 Final/Stage IV/ Japan 2014 (Tier 4 Final)	
Flywheel Power:								
Hydrostatic	97 kW	130 hp	97 kW	130 hp	97 kW	130 hp	97 kW	130 hp
Operating Weight:								
Hydrostatic	13 311 kg	29,346 lb	13 948 kg	30,750 lb	13 311 kg	29,346 lb	13 948 kg	30,750 lb
Engine Model	C7.1 ACERT		C7.1 ACERT		C4.4 ACERT		C4.4 ACERT	
Rated Engine RPM	2200		2200		2200		2200	
No. of Cylinders	6		6		4		4	
Bore	105 mm	4.13"	105 mm	4.13"	105 mm	4.13"	105 mm	4.13"
Stroke	127 mm	5.0"	127 mm	5.0"	127 mm	5.0"	127 mm	5.0"
Displacement	6.6 L	403 in³	6.6 L	403 in³	4.4 L	269 in³	4.4 L	269 in³
Track Rollers (Each Side)	7 or 8		7 or 8		8		8	
Width of Standard Track Shoe	560 mm	22"	760 mm	30"	560 mm	22"	760 mm	30"
Length of Track on Ground	2645 mm	104"	2645 mm	104"	2645 mm	104"	2645 mm	104"
Ground Contact Area (w/Std. Shoe)	3.0 m ²	4650 in²	4.0 m ²	6200 in²	3.0 m ²	4650 in²	4.0 m ²	6200 in²
Track Gauge	1770 mm	70"	2000 mm	79"	1770 mm	70"	2000 mm	79"
GENERAL DIMENSIONS:								
Height (To Top of ROPS Cab)	2958 mm	116.5"	2958 mm	116.5"	2958 mm	116.5"	2958 mm	116.5"
Overall Length								
(with VPAT Blade)**	5008 mm	197"	5008 mm	197"	5008 mm	197"	5008 mm	197"
without Blade**	4588 mm	181"	4588 mm	181"	4588 mm	181"	4588 mm	181"
Width (w/o Trunnion and Blade — Std. Shoe)*	2330 mm	91.7"	2760 mm	108.7"	2330 mm	91.7"	2760 mm	108.7"
Ground Clearance	360 mm	14.2"	360 mm	14.2"	360 mm	14.2"	360 mm	14.2"
Blade Types and Widths:								
VPAT, straight	3196 mm	125.8"	3682 mm	145.0"	3196 mm	125.8"	3682 mm	145.0"
VPAT, angled	2896 mm	114.0"	3337 mm	131.4"	2896 mm	114.0"	3337 mm	131.4"
Fuel Tank Refill Capacity	295 L	77.9 U.S. gal	295 L	77.9 U.S. gal	295 L	77.9 U.S. gal	295 L	77.9 U.S. gal
DEF Exhaust Fluid Refill Capacity	—		—		19 L	5 U.S. gal	19 L	5 U.S. gal

*Width (w/o Trunnion — Std. Shoe) is also w/o VPAT Blade.

**With drawbar.

MODEL	D6N XL		D6N LGP	
Emission Standards	Tier 4 Final/Stage IV/ Japan 2014 (Tier 4 Final)		Tier 4 Final/Stage IV/ Japan 2014 (Tier 4 Final)	
Flywheel Power:				
Power Shift	124 kW	166 hp	124 kW	166 hp
Operating Weight:				
Power Shift Differential Steer	16 757 kg	36,943 lb	18 346 kg	40,446 lb
Engine Model	C7.1 ACERT		C7.1 ACERT	
Rated Engine RPM	2200		2200	
No. of Cylinders	6		6	
Bore	105 mm	4.13"	105 mm	4.13"
Stroke	135 mm	5.3"	135 mm	5.3"
Displacement	7.1 L	433 in³	7.1 L	433 in³
Track Rollers (Each Side)	7		8	
Width of Standard Track Shoe	610 mm	24"	840 mm	33"
Length of Track on Ground	2605 mm	102.6"	3110 mm	122.4"
Ground Contact Area (w/Std. Shoe)	3.18 m ²	4929 in²	5.24 m ²	8122 in²
Track Gauge	1890 mm	74.4"	2160 mm	85"
GENERAL DIMENSIONS:				
Height (To Top of ROPS Canopy)	NA**		NA**	
Height (To Top of ROPS Cab)	3088 mm	121.6"	3202 mm	126"
Overall Length (with VPAT Blade)	5035 mm	198.2"	5401 mm	212.6"
without Blade	3735 mm	147"	4146 mm	163.2"
with SU Blade	5165 mm	203.3"		—
Width (over Trunnion)	2630 mm	103.5"		—
Width (w/o Trunnion — Std. Shoe)*	2500 mm	98.4"	3000 mm	118"
Ground Clearance	394 mm	15.5"	507 mm	20"
Blade Types and Widths:				
Semi-U	3154 mm	124.2"		—
VPAT	3272 mm	128.8"	4080 mm	160.6"
Fuel Tank Refill Capacity	277 L	73.2 U.S. gal	277 L	73.2 U.S. gal
Diesel Exhaust Fluid Refill Capacity	19 L	5 U.S. gal	19 L	5 U.S. gal

*Width (w/o Trunnion — Std. Shoe) is also w/o VPAT Blade.

**Canopy not available.

MODEL	D6R2		D6R2 XL		D6R2 LGP	
Emission Standards	Tier 3/Stage IIIA/ Japan 2006 (Tier 3) equivalent ¹		Tier 3/Stage IIIA/ Japan 2006 (Tier 3) equivalent ¹		Tier 3/Stage IIIA/ Japan 2006 (Tier 3) equivalent ¹	
Flywheel Power:						
Stage II — ISO 9249/SAE J1349	133 kW	179 hp	148 kW	198 hp	148 kW	198 hp
Stage IIIA — ISO 9249/SAE J1349	147 kW	196 hp	153 kW	206 hp	153 kW	206 hp
Operating Weight: ²						
Power Shift Differential Steer (SU Blade)	19 066 kg	42,033 lb	19 914 kg	43,903 lb	21 661 kg	47,754 lb
Engine Model	C9 ACERT		C9 ACERT		C9 ACERT	
Rated Engine RPM:						
Stage II	2000		2000		2000	
Stage IIIA	1850		1850		1850	
No. of Cylinders	6		6		6	
Bore	112 mm	4.4"	112 mm	4.4"	112 mm	4.4"
Stroke	149 mm	5.9"	149 mm	5.9"	149 mm	5.9"
Displacement	8.8 L	537 in³	8.8 L	537 in³	8.8 L	537 in³
Track Rollers (Each Side)	6		7		8	
Width of Standard Track Shoe	560 mm	22"	560 mm	22"	915 mm	36"
Length of Track on Ground	2664 mm	104.9"	2871 mm	113"	3275 mm	128.9"
Ground Contact Area (w/Std. Shoe)	2.98 m ²	4625 in²	3.22 m ²	4984 in²	5.99 m ²	9290 in²
Track Gauge	1880 mm	74"	1880 mm	74"	2286 mm	90.0"
GENERAL DIMENSIONS:						
Height (To Top of ROPS Cab/Canopy)	3216 mm	126.6"	3216 mm	126.6"	3266 mm	128.6"
Height (To Exhaust Stack)	3115 mm	122.6"	3115 mm	122.6"	3165 mm	124.6"
Length of Basic Tractor (w/o Blade)	3860 mm	152.0"	3860 mm	152.0"	4247 mm	167.2"
with following attachments, add:						
S Blade	1043 mm	41.1"	—		1218 mm	48.0"
SU Blade	1235 mm	48.6"	1472 mm	58.0"	—	
Angle Blade (when Straight)	1147 mm	45.2"	1349 mm	53.1"	—	
Angle Blade (when Angled 25°)	1983 mm	78.1"	2185 mm	86.0"	—	
Rear Drawbar	366 mm	14.4"	366 mm	14.4"	251 mm	9.9"
Multi-Shank Ripper (tip at ground level)	1403 mm	55.2"	1403 mm	55.2"	—	
Width of Tractor:						
Over Trunnion	2640 mm	103.9"	2640 mm	103.9"	3491 mm	137.4"
Without Trunnion (standard shoe width)	2440 mm	96.1"	2440 mm	96.1"	3201 mm	126.0"
Ground Clearance	372 mm	14.6"	372 mm	14.6"	422 mm	16.6"
Blade Types and Widths:						
S Blade	3360 mm	132.3"	—		4063 mm	160.0"
SU Blade	3260 mm	128.3"	3260 mm	128.3"	—	
Angle Blade	4166 mm	164.0"	4166 mm	164.0"	—	
Fuel Tank Refill Capacity	424 L	112 U.S. gal	424 L	112 U.S. gal	424 L	112 U.S. gal

¹ Meets Tier 2/Stage II/Japan 2001 (Tier 2) equivalent OR Tier 3/Stage IIIA/Japan 2006 (Tier 3) equivalent emission standards.

² Operating weight includes ROPS canopy, operator lubricants, coolants, full fuel tank, hydraulic controls and fluid, SU blades, horn, backup alarm, retrieval hitch and front pull hook.

MODEL	D6T		D6T XL	
	Tier 3/Stage IIIA/ Japan 2006 (Tier 3) equivalent		Tier 3/Stage IIIA/ Japan 2006 (Tier 3) equivalent	
Emission Standards				
Flywheel Power	149 kW	200 hp	149 kW	200 hp
Operating Weight: ¹				
Power Shift Differential Steer				
SU Blade	20 580 kg	45,370 lb	21 600 kg	47,620 lb
Engine Model	C9 ACERT		C9 ACERT	
Rated Engine RPM: Power Shift	1850		1850	
No. of Cylinders	6		6	
Bore	112 mm	4.4"	112 mm	4.4"
Stroke	149 mm	5.9"	149 mm	5.9"
Displacement	8.8 L	537 in ³	8.8 L	537 in ³
Track Rollers (Each Side)	6		7	
Width of Standard Track Shoe	560 mm	22"	560 mm	22"
Length of Track on Ground	2.61 m	8'7"	2.81 m	9'3"
Ground Contact Area (w/Std. Shoe)	2.92 m ²	4531 in ²	3.15 m ²	4878 in ²
Track Gauge	1.88 m	74"	1.88 m	74"
GENERAL DIMENSIONS:				
Height ² (Stripped Top) ³	2.40 m	7'11"	2.40 m	7'11"
Height ² (To Top of ROPS Canopy)	3.11 m	10'2"	3.11 m	10'2"
Height ² (To Top of ROPS Cab)	3.11 m	10'2"	3.11 m	10'2"
Overall Length (without Blade)	3.85 m	12'7"	3.85 m	12'7"
with SU Blade	5.08 m	16'8"	5.33 m	17'6"
with Angle Blade	5.00 m	16'5"	5.21 m	17'1"
Width (over Trunnion)	2.64 m	8'8"	2.64 m	8'8"
Width (w/o Trunnion — Std. Track)	2.44 m	8'0"	2.44 m	8'0"
Ground Clearance ²	384 mm	1'3"	384 mm	1'3"
Blade Types and Widths:				
Angle Straight	4.16 m	13'8"	4.16 m	13'8"
Full 25° Angle	3.77 m	12'5"	3.77 m	12'5"
Semi-U	3.26 m	10'8"	3.26 m	10'8"
Fuel Tank Refill Capacity	425 L	112 U.S. gal	425 L	112 U.S. gal

¹ Operating weight includes cab, operator, lubricants, coolant, full fuel tank, standard track, hydraulic controls and fluid, SU blade, drawbar and counterweight.

² Dimensions measured from ground line. Add grouser height for total dimension on hard surfaces.

³ Height (Stripped Top) — without ROPS canopy, exhaust, seat back or other easily removed encumbrances.

Track-Type Tractor Sustainability

Well matched engine and power train systems enhance productivity and fuel efficiency.

MODEL	D6T XL		D6T XW		D6T LGP	
Emission Standards	Tier 4 Final/Stage IV/ Japan 2014 (Tier 4 Final)		Tier 4 Final/Stage IV/ Japan 2014 (Tier 4 Final)		Tier 4 Final/Stage IV/ Japan 2014 (Tier 4 Final)	
Flywheel Power	151 kW	202 hp	151 kW	202 hp	151 kW	202 hp
Operating Weight: ¹						
Power Shift Differential Steer	20 985 kg	46,263 lb	21 788 kg	48,034 lb	22 902 kg	50,490 lb
VPAT	23 663 kg	52,167 lb	24 118 kg	53,170 lb	24 336 kg	53,651 lb
Engine Model	C9.3 ACERT		C9.3 ACERT		C9.3 ACERT	
Advertised Engine RPM	2000		2000		2000	
No. of Cylinders	6		6		6	
Bore	115 mm	4.5"	115 mm	4.5"	115 mm	4.5"
Stroke	149 mm	5.9"	149 mm	5.9"	149 mm	5.9"
Displacement	9.3 L	567 in ³	9.3 L	567 in ³	9.3 L	567 in ³
Track Rollers (Each Side)	7		7		8	
VPAT	7		8		8	
Width of Standard Track Shoe	560 mm	22"	760 mm	30"	915 mm	36"
VPAT	560 mm	22"	710 mm	28"	785 mm	31"
Length of Track on Ground	2.84 m	9'5"	2.84 m	9'5"	3.25 m	10'9"
VPAT	2.84 m	9'5"	3.25 m	10'9"	3.25 m	10'9"
Ground Contact Area (w/Std. Shoe)	3.54 m ²	5489 in ²	4.81 m ²	7449 in ²	6.53 m ²	10,122 in ²
VPAT	3.54 m ²	5489 in ²	5.10 m ²	7909 in ²	5.60 m ²	8684 in ²
Track Gauge	1.88 m	74"	2.03 m	80"	2.29 m	90"
VPAT	2.13 m	84"	2.29 m	90"	2.29 m	90"
GENERAL DIMENSIONS:						
Height ² (Stripped Top ³)	2.46 m	8'1"	2.46 m	8'1"	2.51 m	8'3"
VPAT	2.46 m	8'1"	2.51 m	8'3"	2.51 m	8'3"
Height ² (To Top of ROPS Canopy)	3.11 m	10'2"	3.11 m	10'2"	3.16 m	10'4"
VPAT	3.11 m	10'2"	3.16 m	10'4"	3.16 m	10'4"
Height ² (To Top of ROPS Cab)	3.15 m	10'4"	3.15 m	10'4"	3.20 m	10'6"
VPAT	3.15 m	10'4"	3.20 m	10'6"	3.20 m	10'6"
Overall Length (without Blade)	3.89 m	12'9"	3.89 m	12'9"	4.25 m	13'11"
VPAT	3.89 m	12'9"	4.25 m	13'11"	4.25 m	13'11"
with S Blade	—		—		5.50 m	18'1"
with SU Blade	5.33 m	17'6"	5.33 m	17'6"	—	
with VPAT Blade	5.39 m	17'8"	5.53 m	18'2"	5.53 m	18'2"
with Angle Blade	5.21 m	17'1"	5.29 m	17'4"	5.81 m	19'1"
Width (over Trunnion)	2.69 m	8'10"	2.94 m	9'8"	3.48 m	11'5"
Width (w/o Trunnion — Std. Track)	2.59 m	8'6"	2.79 m	9'2"	3.20 m	10'6"
VPAT	2.72 m	8'11"	3.00 m	9'10"	3.14 m	10'4"
Ground Clearance ²	372 mm	1'3"	372 mm	1'3"	406 mm	1'4"
VPAT	372 mm	1'3"	406 mm	1'4"	406 mm	1'4"
Blade Types and Widths:						
Straight	—		—		4.06 m	13'4"
Angle Straight	4.16 m	13'8"	4.52 m	14'10"	5.07 m	16'8"
Full 25° Angle	3.77 m	12'5"	4.11 m	13'6"	4.63 m	15'2"
Semi-U	3.26 m	12'8"	3.56 m	11'8"	—	
VPAT						
Straight	3.88 m	12'9"	4.16 m	13'8"	4.16 m	13'8"
Full 24° Angle	3.54 m	11'7"	3.79 m	12'5"	3.79 m	12'5"
Fuel Tank Refill Capacity	411 L	109 U.S. gal	411 L	109 U.S. gal	411 L	109 U.S. gal

¹ Operating weight includes cab, operator, lubricants, coolant, full fuel tank, standard track, hydraulic controls and fluid, SU blade and drawbar.

² Dimensions measured from ground line. Add grouser height for total dimension on hard surfaces.

³ Height (Stripped Top) — without ROPS canopy, exhaust, seat back or other easily removed encumbrances.

MODEL	D7E		D7E LGP	
Emission Standards	Tier 4 Final/Stage IV/ Japan 2014 (Tier 4 Final)		Tier 4 Final/Stage IV/ Japan 2014 (Tier 4 Final)	
Advertised Flywheel Power	178 kW	238 hp	178 kW	238 hp
Operating Weight: ¹				
Electric Drive Differential Steer	26 055 kg	57,441 lb	28 525 kg	62,886 lb
Engine Model	C9.3 ACERT		C9.3 ACERT	
Advertised Engine RPM	1700		1700	
No. of Cylinders	6		6	
Bore	115 mm	4.5"	115 mm	4.5"
Stroke	149 mm	5.9"	149 mm	5.9"
Displacement	9.3 L	567 in ³	9.3 L	567 in ³
Track Rollers (Each Side)	7		8	
Width of Standard Track Shoe	610 mm	24"	915 mm	36"
Length of Track on Ground	3.02 m	9'11"	3.45 m	11'4"
Ground Contact Area (w/Std. Shoe)	3.68 m ²	5698 in ²	6.31 m ²	9792 in ²
Track Gauge	1.98 m	6'6"	2.29 m	7'6"
GENERAL DIMENSIONS:				
Height ² (To Top of ROPS Cab)	3.32 m	10'11"	3.32 m	10'11"
Overall Length (without Blade)	4.88 m	16'0"	4.88 m	16'0"
with S Blade	5.86 m	19'3"	5.56 m	18'3"
with SU Blade	6.07 m	19'11"	—	—
Width (over Trunnion)	2.88 m	9'5"	3.42 m	11'3"
Width (w/o Trunnion — Std. Shoe)	2.59 m	8'6"	3.2 m	10'6"
Ground Clearance	472 mm	18.6"	472 mm	18.6"
Blade Types and Widths:				
Straight	3.9 m	12'10"	4.54 m	14'11"
Angle Straight	4.5 m	14'9"	—	—
Full 25° Angle	4.12 m	13'6"	—	—
Universal	3.99 m	13'1"	—	—
Semi-U	3.71 m	12'2"	—	—
Fuel Tank Refill Capacity	430 L	114 U.S. gal	430 L	114 U.S. gal

¹ Operating weight includes cab, operator, lubricants, coolant, full fuel tank, standard track, hydraulic controls and fluid, SU blade and drawbar.

² Dimensions measured from ground line. Add grouser height for total dimension on hard surfaces.

Cat D7E — Resourceful in every way

- The D7E is designed to maximize efficiency and productivity while conserving natural resources.
- Burns 10–30% less fuel per hour than previous models. Less fuel burned means reduced emissions.
- The D7E earned a 2009 Clean Air Excellence Award from the U.S. Environmental Protection Agency.
- More efficient – 25% more material moved per liter/gallon of fuel.
- Fewer parts and longer component life, less fuel and fluids, means less to replace and less to dispose.
- Major structures and components are built to be rebuilt, reducing waste and replacement costs.

MODEL	D7R		D7R XR		D7R LGP	
Emission Standards	Tier 2/Stage II/ Japan 2001 (Tier 2) equivalent ¹		Tier 2/Stage II/ Japan 2001 (Tier 2) equivalent ¹		Tier 2/Stage II/ Japan 2001 (Tier 2) equivalent ¹	
Flywheel Power	179 kW	240 hp	179 kW	240 hp	179 kW	240 hp
Operating Weight: ²						
Power Shift Differential Steer	25 455 kg	56,129 lb	27 002 kg	59,540 lb	27 626 kg	60,916 lb
Engine Model	C9 ACERT		C9 ACERT		C9 ACERT	
Rated Engine RPM: Power Shift	2100		2100		2100	
No. of Cylinders	6		6		6	
Bore	112 mm	4.4"	112 mm	4.4"	112 mm	4.4"
Stroke	149 mm	5.9"	149 mm	5.9"	149 mm	5.9"
Displacement	8.8 L	537 in ³	8.8 L	537 in ³	8.8 L	537 in ³
Track Rollers (Each Side)	7		8		8	
Width of Standard Track Shoe	560 mm	22"	560 mm	22"	914 mm	36"
Length of Track on Ground	2.87 m	9'5"	3.05 m	10'0"	3.16 m	10'5"
Ground Contact Area (w/Std. Shoe)	3.22 m ²	4991 in ²	3.42 m ²	5295 in ²	5.78 m ²	8960 in ²
Track Gauge	1980 mm	6'6"	1980 mm	6'6"	2235 mm	7'4"
GENERAL DIMENSIONS:						
Height ³ (Stripped Top) ⁴	2.58 m	8'6"	2.58 m	8'6"	2.7 m	8'10"
Height ³ (To Top of ROPS Canopy)	3.29 m	10'9"	3.29 m	10'9"	3.37 m	11'1"
Height ³ (To Top of ROPS Cab)	3.28 m	10'9"	3.28 m	10'9"	3.36 m	11'0"
Overall Length (without Blade)	4.73 m	15'6"	4.73 m	15'6"	4.73 m	15'6"
with following attachments, add:						
with S Blade	—		—		1071 mm	42.2"
with SU Blade	1301 mm	51.2"	1301 mm	51.2"	—	
with A Blade (Straight)	1372 mm	54.0"	1372 mm	54.0"	—	
Rear Drawbar	1188 mm	46.7"	1188 mm	46.7"	1188 mm	46.7"
Multi-Shank Ripper (tip at ground level)	2442 mm	96.1"	2442 mm	96.1"	2442 mm	96.1"
Width (over Trunnion)	2.88 m	9'5"	2.88 m	9'5"	3.37 m	11'1"
Width (w/o Trunnion — Std. Shoe)	2.54 m	8'4"	2.54 m	8'4"	3.15 m	10'4"
Ground Clearance	415 mm	1'4"	415 mm	1'4"	495 mm	1'7"
Blade Types and Widths:						
Straight Blade	—		—		4545 mm	178.9"
Semi-U Blade	3.69 m	12'2"	3.69 m	12'2"	—	
Angle Blade	4496 mm	177.0"	4496 mm	177.0"	—	
Fuel Tank Refill Capacity	481 L	127 U.S. gal	481 L	127 U.S. gal	481 L	127 U.S. gal

¹ Meets Tier 2/Stage II/Japan 2001 (Tier 2) equivalent OR Tier 3/Stage IIIA/Japan 2006 (Tier 3) equivalent emission standards.

² Operating weight includes cab, operator, lubricants, coolant, full fuel tank, standard track, hydraulic controls and fluid, SU blade, drawbar and counterweight.

³ Dimensions measured from ground line. Add grouser height for total dimension on hard surfaces.

⁴ Height (Stripped Top) — without ROPS canopy, exhaust, seat back or other easily removed encumbrances.

Track-Type Tractor Sustainability

Major structures and components are built to be rebuilt, reducing waste and replacement costs.

MODEL	D8R		D8R LGP	
	Tier 1/Stage I		Tier 1/Stage I	
Emission Standards				
Flywheel Power	226 kW	303 hp	226 kW	303 hp
Operating Weight: ¹				
Power Shift Differential Steer	37 920 kg	83,600 lb	35 176 kg	77,550 lb
Engine Model	3406C TA		3406C TA	
Rated Engine RPM	2100		2100	
No. of Cylinders	6		6	
Bore	137 mm	5.4"	137 mm	5.4"
Stroke	165 mm	6.5"	165 mm	6.5"
Displacement	14.6 L	893 in ³	14.6 L	893 in ³
Track Rollers (Each Side)	8		8	
Width of Standard Track Shoe	610 mm	24"	965 mm	38"
Length of Track on Ground	3.21 m	10'6"	3.26 m	10'8"
Ground Contact Area (w/Std. Shoe)	3.91 m ²	6062 in ²	6.3 m ²	9746 in ²
Track Gauge	2.08 m	6'10"	2.34 m	7'8"
GENERAL DIMENSIONS:				
Height ² (Stripped Top) ³	2.67 m	8'9"	2.67 m	8'9"
Height ² (To Top of ROPS Canopy)	3.45 m	11'4"	3.51 m	11'6"
Height ² (To Top of ROPS Cab)	3.42 m	11'3"	3.49 m	11'5"
Overall Length (with SU Blade) ⁴	6.80 m	22'4"	6.80 m	22'4"
(without Blade)	4.96 m	16'3"	4.96 m	16'3"
Overall Length (without Blade)	—	—	—	—
with S Blade	—	—	—	—
Width (over Trunnion)	3.05 m	10'0"	3.38 m	11'1"
Width (w/o Trunnion — Std. Shoe)	2.70 m	8'8"	3.30 m	10'10"
Ground Clearance	613 mm	2'0"	606 mm	2'0"
Blade Types and Widths:				
Straight	—	—	—	—
Angle Straight	4.99 m	16'4"	—	—
Full 25° Angle	4.52 m	14'10"	—	—
Universal	4.26 m	14'0"	—	—
Semi-U	3.94 m	12'11"	4.40 m	14'5"
Fuel Tank Refill Capacity	625 L	165 U.S. gal	625 L	165 U.S. gal

¹ Operating weight includes cab, operator, lubricants, coolant, full fuel tank, standard track, hydraulic controls and fluid, SU blade, drawbar and counterweight.
— D8R equipped with track guides, ROPS/FOPS cab, single shank ripper and SU blade.

² Dimensions measured from ground line. Add grouser height for total dimension on hard surfaces.

³ Height (Stripped Top) — without ROPS canopy, exhaust, seat back or other easily removed encumbrances.

⁴ Includes drawbar.

Track-Type Tractor Sustainability

Cat tractors are designed for ease of serviceability, with features like ground-level service points and wide engine enclosure doors.

MODEL	D8T		D8T LGP		D8T		D8T LGP	
Emission Standards	Tier 4 Interim/ Stage IIIA		Tier 4 Interim/ Stage IIIA		Tier 4 Final/Stage IV/ Japan 2014 (Tier 4 Final)		Tier 4 Final/Stage IV/ Japan 2014 (Tier 4 Final)	
Flywheel Power	233 kW	312 hp	233 kW	312 hp	233 kW	312 hp	233 kW	312 hp
Operating Weight: ¹								
Power Shift Differential Steer	39 751 kg	87,650 lb	37 750 kg	83,224 lb	39 795 kg	87,733 lb	37 795 kg	83,324 lb
Engine Model	C15 ACERT		C15 ACERT		C15 ACERT		C15 ACERT	
Rated Engine RPM	1900		1900		1900		1900	
No. of Cylinders	6		6		6		6	
Bore	137 mm	5.4"	137 mm	5.4"	137 mm	5.4"	137 mm	5.4"
Stroke	172 mm	6.75"	172 mm	6.75"	172 mm	6.75"	172 mm	6.75"
Displacement	15.2 L	928 in³	15.2 L	928 in³	15.2 L	928 in³	15.2 L	928 in³
Track Rollers (Each Side)	8		8		8		8	
Width of Standard Track Shoe	610 mm	24"	965 mm	38"	610 mm	24"	965 mm	38"
Length of Track on Ground	3.21 m	10'6"	3.20 m	10'6"	3.21 m	10'6"	3.21 m	10'6"
Ground Contact Area (w/Std. Shoe)	3.91 m ²	6062 in²	6.19 m ²	9593 in²	3.91 m ²	6062 in²	6.19 m ²	9593 in²
Track Gauge	2.08 m	6'10"	2.34 m	7'8"	2.08 m	6'10"	2.34 m	7'8"
GENERAL DIMENSIONS:								
Height ² (Stripped Top) ³	2.67 m	8'9"	2.67 m	8'9"	—	—	—	—
Height ² (To Top of ROPS Canopy)	3.46 m	11'4"	3.45 m	11'4"	—	—	—	—
Height ² (To Top of ROPS Cab)	3.46 m	11'4"	3.46 m	11'4"	3.51 m	11'6"	3.51 m	11'6"
Overall Length (with SU Blade) ⁴	6.09 m	20'0"	6.09 m	20'0"	6.09 m	20'0"	6.09 m	20'0"
(without Blade)	4.64 m	15'3"	4.98 m	16'4"	4.64 m	15'3"	4.98 m	16'4"
Width (over Trunnion)	3.06 m	10'0"	3.38 m	11'1"	3.06 m	10'0"	3.38 m	11'1"
Width (w/o Trunnion — Std. Shoe)	2.64 m	8'8"	3.30 m	10'10"	2.64 m	8'8"	3.30 m	10'10"
Ground Clearance	613 mm	2'0"	613 mm	2'0"	613 mm	2'0"	613 mm	2'0"
Blade Types and Widths:								
Angle Straight	4.99 m	16'4"	—	—	4.99 m	16'4"	—	—
Full 25° Angle	5.05 m	16'7"	—	—	5.05 m	16'7"	—	—
Universal	4.26 m	14'0"	—	—	4.26 m	14'0"	—	—
Semi-U	3.94 m	12'11"	4.53 m	14'10"	3.94 m	12'11"	4.53 m	14'10"
Fuel Tank Refill Capacity	627 L	165 U.S. gal	627 L	165 U.S. gal	627 L	165 U.S. gal	627 L	165 U.S. gal

¹ Operating weight includes ROPS/FOPS cab, operator, lubricants, coolant, full fuel tank, standard track, hydraulic controls and fluid, SU blade and ripper.
LGP operating weight includes drawbar instead of ripper.

² Dimensions measured from ground line. Add grouser height for total dimension on hard surfaces.

³ Height (Stripped Top) — without ROPS canopy, exhaust, seat back or other easily removed encumbrances.

⁴ Includes drawbar.

Track-Type Tractor Sustainability

Cat engines with ACERT Technology provide powerful reliability, while meeting the stringent emissions standards.

MODEL	D9R		D9T		D9T	
Emission Standards	—		Tier 3/Stage IIIA/ Japan 2006 (Tier 3) equivalent ¹		Tier 4 Final/Stage IV/ Japan 2014 (Tier 4 Final)	
Flywheel Power	302 kW	405 hp	306 kW	410 hp	325 kW	436 hp
Operating Weight: ²						
Power Shift Clutch Brake	48 784 kg	107,548 lb	—		—	
Power Shift Differential Steer	—		47 872 kg	105,539 lb	48 361 kg	106,618 lb
Engine Model	3408C SCAC		C18 ACERT		C18 ACERT	
Rated Engine RPM	1900		1833		1800	
No. of Cylinders	8		6		6	
Bore	137 mm	5.4"	145 mm	5.7"	145 mm	5.7"
Stroke	152 mm	6"	183 mm	7.2"	183 mm	7.2"
Displacement	18 L	1099 in³	18.1 L	1106 in³	18.1 L	1106 in³
Track Rollers (Each Side)	8		8		8	
Width of Standard Track Shoe	610 mm	24"	610 mm	24"	610 mm	24"
Length of Track on Ground	3.47 m	11'5"	3.47 m	11'5"	3.47 m	11'5"
Ground Contact Area (w/Std. Shoe)	4.24 m ²	6569 in²	4.24 m ²	6569 in²	4.24 m ²	6569 in²
Track Gauge	2.25 m	7'5"	2.25 m	7'5"	2.25 m	7'5"
GENERAL DIMENSIONS:						
Height ³ (Stripped Top) ⁴	3.69 m	12'1"	3.69 m	12'1"	3.69 m	12'1"
Height ³ (To Top of ROPS Canopy)	4.00 m	13'1"	4.00 m	13'1"	4.00 m	13'1"
Height ³ (To Top of FOPS Cab)	3.82 m	12'6"	3.82 m	12'6"	3.82 m	12'6"
Overall Length (with SU Blade) ⁵	6.88 m	22'6"	6.88 m	22'6"	6.88 m	22'6"
(without Blade)	5.18 m	17'0"	5.18 m	17'0"	5.18 m	17'0"
(with SU Blade and Ripper) ⁵	8.23 m	27'0"	8.23 m	27'0"	8.23 m	27'0"
(without Blade and Ripper)	4.91 m	16'1"	4.91 m	16'1"	4.91 m	16'1"
Width (over Trunnion)	3.30 m	10'8"	3.30 m	10'8"	3.30 m	10'8"
Width (w/o Trunnion — Std. Shoe)	2.88 m	9'5"	2.88 m	9'5"	2.88 m	9'5"
Ground Clearance ⁶	496 mm	1'7"	496 mm	1'7"	496 mm	1'7"
Blade Types and Widths:						
Universal	4.65 m	15'3"	4.65 m	15'3"	4.65 m	15'3"
Semi-U	4.31 m	14'2"	4.31 m	14'2"	4.31 m	14'2"
Fuel Tank Refill Capacity	818 L	216 U.S. gal	889 L	235 U.S. gal	821 L	217 U.S. gal
DEF Tank Capacity	—		—		36 L	9.5 U.S. gal

¹ Product available to meet Tier 2/Stage II/ Japan 2001 (Tier 2) equivalent OR Tier 3/Stage IIIA/ Japan 2006 (Tier 3) equivalent emission standards.

² Operating weight includes ROPS canopy, operator, lubricants, coolant, full fuel tank, hydraulic controls and fluids, semi universal blade with tilt, back-up alarm, seat belts, lights, and single shank ripper.

— D9R equipped with track guides, ROPS/FOPS cab, single shank ripper and SU blade.

³ Dimensions measured from ground line. Add grouser height for total dimension on hard surfaces.

⁴ Height (Stripped Top) — without ROPS canopy, exhaust, seat back or other easily removed encumbrances.

⁵ Includes drawbar.

⁶ Per ISO 6746 — Must add grouser height for total dimension on hard surfaces.

MODEL	D10T2		D11T		D11T CD	
Emission Standards	Tier 4 Final/Stage IV/ Japan 2014 (Tier 4 Final) ¹		Tier 4 Final/Stage IV/ Japan 2014 (Tier 4 Final) ¹		Tier 4 Final/Stage IV/ Japan 2014 (Tier 4 Final) ¹	
Flywheel Power	447 kW	600 hp	634 kW	850 hp	634 kW	850 hp
Reverse Gears	538 kW	722 hp	—	—	—	—
Operating Weight: ²						
Power Shift Clutch Brake	70 171 kg	154,700 lb	104 236 kg	229,800 lb	112 718 kg	248,500 lb
Engine Model	C27 ACERT		C32 ACERT		C32 ACERT	
Rated Engine RPM	1800		1800		1800	
No. of Cylinders	12		12		12	
Bore	137 mm	5.4"	145 mm	5.71"	145 mm	5.71"
Stroke	152 mm	6"	162 mm	6.38"	162 mm	6.38"
Displacement	27 L	1648 in ³	32.1 L	1959 in ³	32.1 L	1959 in ³
Track Rollers (Each Side)	8		8		8	
Width of Standard Track Shoe	610 mm	24"	710 mm	28"	915 mm	36"
Length of Track on Ground (Idler to Idler)	3.88 m	12'9"	4.44 m	14'7"	4.44 m	14'7"
Ground Contact Area (w/Std. Shoe)	4.74 m ²	7347 in ²	6.31 m ²	9781 in ²	8.13 m ²	12,605 in ²
Track Gauge	2.55 m	8'4"	2.89 m	9'6"	2.89 m	9'6"
GENERAL DIMENSIONS:						
Height (Stripped Top) ³	3.222 m	10'7"	3.64 m	11'11"	3.64 m	11'11"
Height (To Top of ROPS Canopy)	4.41 m	14'5"	4.70 m	15'5"	4.70 m	15'5"
Height (To Top of FOPS Cab)	4.10 m	13'5"	4.39 m	14'5"	4.39 m	14'5"
Overall Length:						
(with SU Blade and SS Ripper) ⁴	9.16 m	30'1"	10.59 m	34'9"	10.70 m	35'1"
(without Blade and Ripper) ⁵	5.32 m	17'5"	6.16 m	20'3"	6.16 m	20'3"
Width (over Trunnion)	3.74 m	12'3"	4.38 m	14'4"	4.38 m	14'4"
Width (w/o Trunnion — Std. Shoe)	3.30 m	10'10"	3.78 m	12'5"	3.81 m	12'6"
Ground Clearance ⁶	632 mm	2'1"	675 mm	2'3"	675 mm	2'3"
Blade Types and Widths:						
CarryDozer	—	—	—	—	6.71 m	22'0"
Universal	5.26 m	17'3"	6.36 m	20'10"	—	—
Semi-U	4.94 m	16'3"	5.60 m	18'4"	—	—
Fuel Tank Refill Capacity	1204 L	314 U.S. gal	1609 L	425 U.S. gal	1609 L	425 U.S. gal
Fuel Tank Refill Capacity (Extra Capacity)	—	—	1987 L	505 U.S. gal	1987 L	505 U.S. gal

¹ Product available to meet Tier 2/Stage II/ Japan 2001 (Tier 2) equivalent OR Tier 4/Stage IV/ Japan 2014 (Tier 4 Final) emission standards.

² Operating weight includes coolant, lubricants, full fuel tank, ROPS, FOPS cab, SU ABR bulldozer (D10T2) or U ABR bulldozer (D11T), dual tilt, single-shank ripper with pin-puller, fast fuel, standard ES shoes, and operator.

D11T CD has 11 Carrydozer and single-shank Carrydozer ripper.

³ Height (Stripped Top) — without ROPS canopy, cab, exhaust, lift cylinders, seat back or other easily removed encumbrances.

⁴ Overall length of D11T CD includes Straight (CarryDozer) Blade and SS Ripper.

⁵ Overall length of machine from front tag link trunnion to rigid drawbar and excludes track grouser height.

⁶ Per ISO 6746 — Must add grouser height for total dimension on hard surfaces.

All dimensions are approximate.

**D3K2 XL
D3K2 LGP**

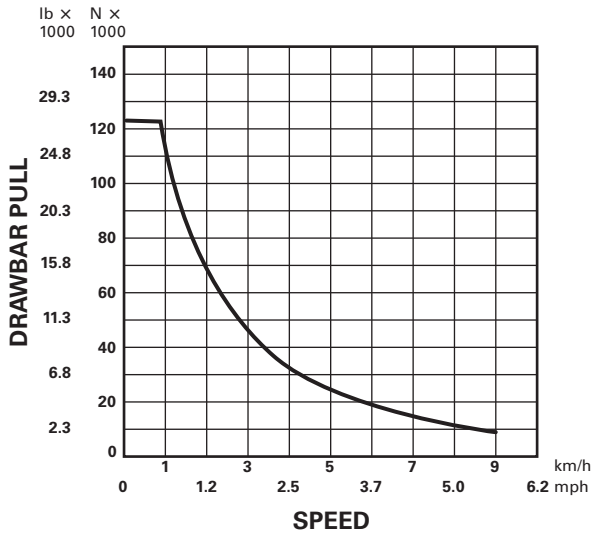

NOTES: Usable pull will depend upon weight and traction of equipped tractor.

Assumes sufficient machine weight for <5% track slip at POR pressure.

Assumes pumps and motors are broken in.

Assumes nominal engine power and valve settings.

Drawbar pull at track stall will be lower.

**D4K2 XL
D4K2 LGP**

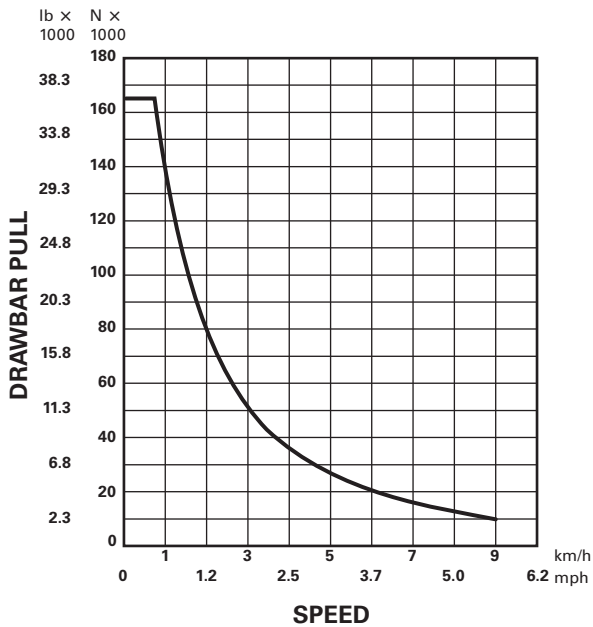

**D5K2 XL
 D5K2 LGP**

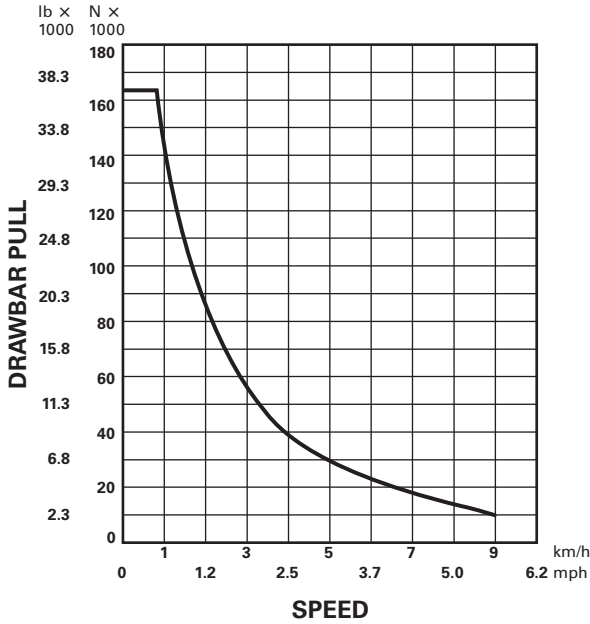

NOTES: Usable pull will depend upon weight and traction of equipped tractor.

Assumes sufficient machine weight for <5% track slip at POR pressure.

Assumes pumps and motors are broken in.

Assumes nominal engine power and valve settings.

Drawbar pull at track stall will be lower.

D6K2 XL/D6K2 LGP

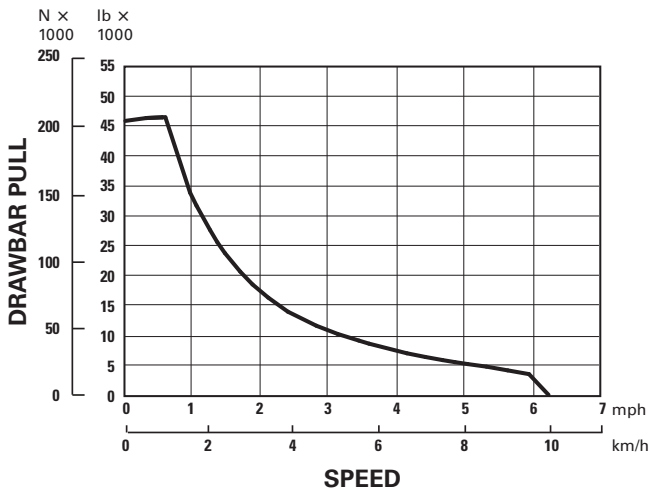

D5R2 XL/LGP and D5T XL
D6N XL/LGP

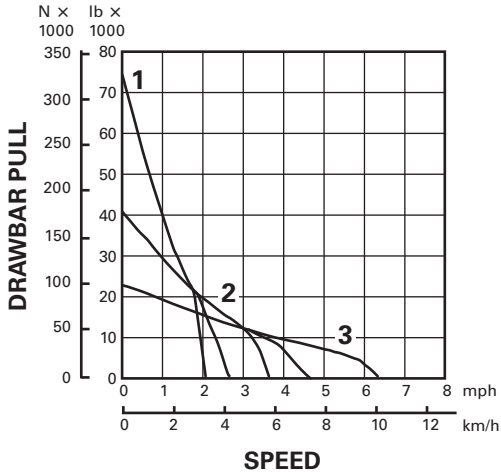

D6N XL/LGP Tier 4 Final/Stage IV/
Japan 2014 (Tier 4 Final)

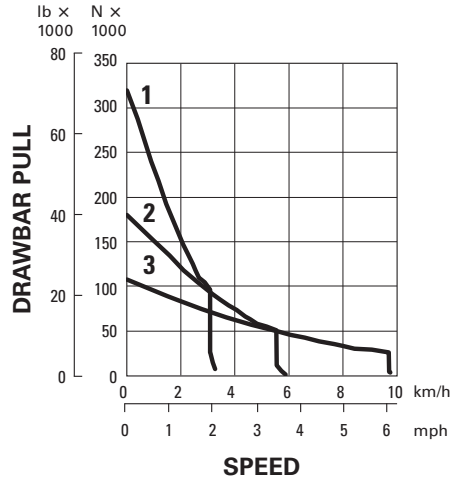

D6R2 Tier 2/Stage II/
Japan 2001 (Tier 2) equivalent

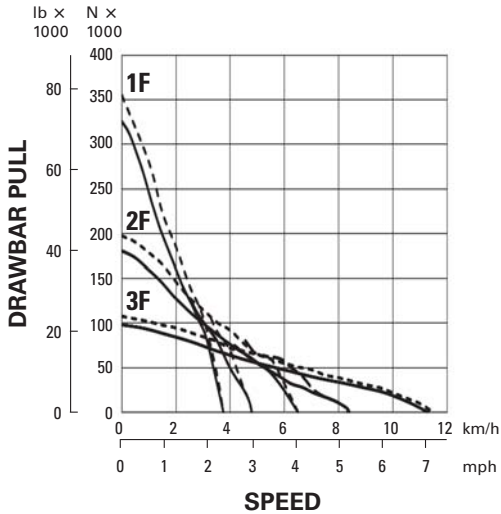

D6R2 Tier 3/Stage IIIA/
Japan 2006 (Tier 3) equivalent

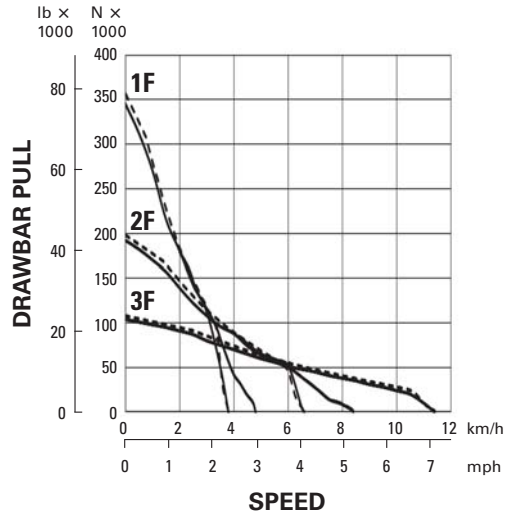

KEY

- STD
- - - - XL/LGP

NOTE: Usable pull will depend upon weight and traction of equipped tractor.

D6T XL/XW/LGP

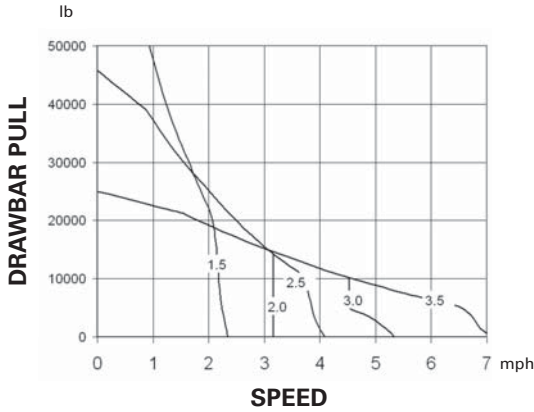

**D6T Tier 4 Final/Stage IV/
Japan 2014 (Tier 4 Final)**

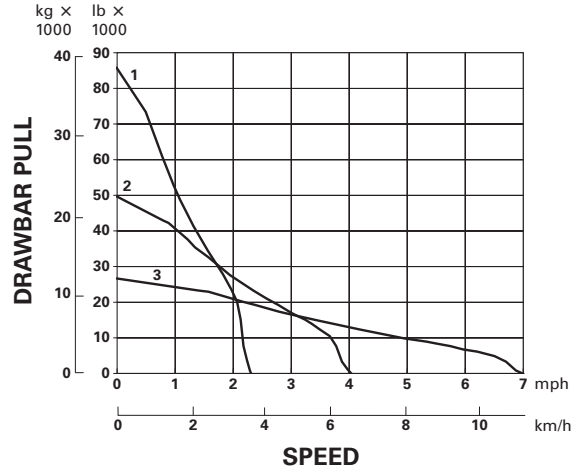

D7E

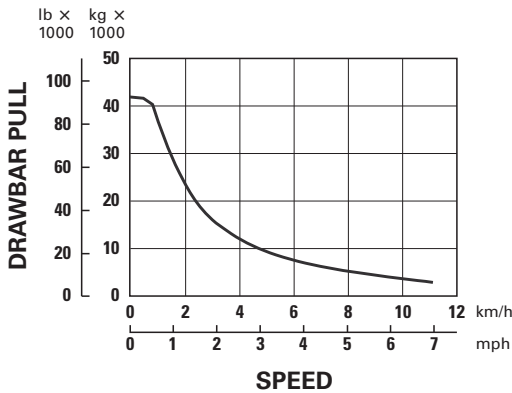

**D7R Standard/XR/LGP
Differential Steer**

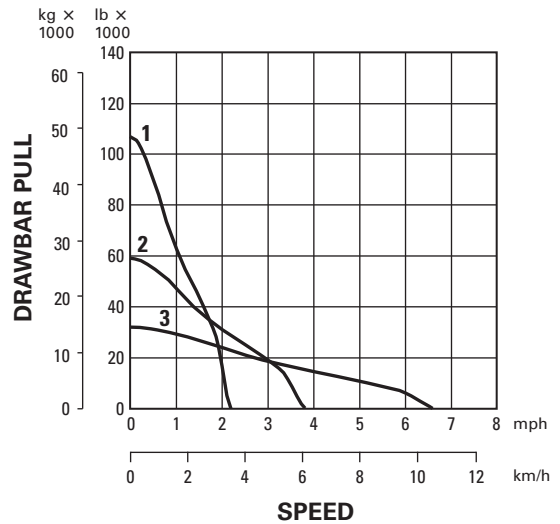

KEY

- 1 — 1st Gear
- 2 — 2nd Gear
- 3 — 3rd Gear

NOTE: Usable pull will depend upon weight and traction of equipped tractor.

**D8R
D8R LGP**

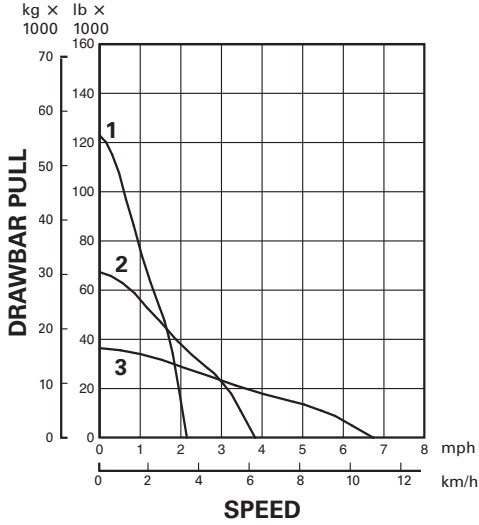

**D8T
D8T LGP**

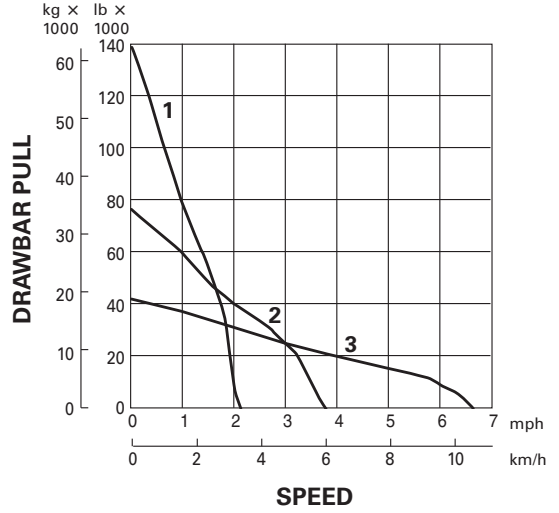

**D8T Tier 4 Final/Stage IV/
Japan 2014 (Tier 4 Final)**

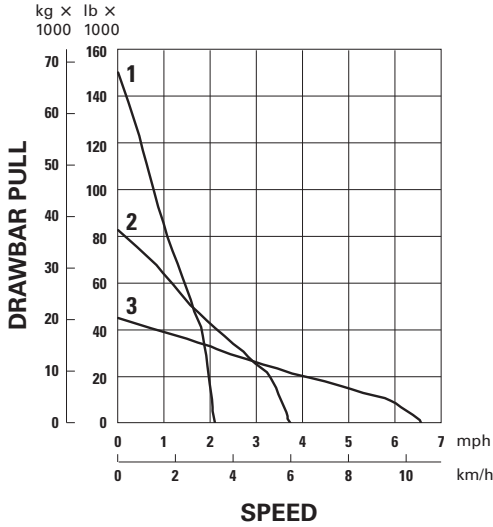

**D9R Power Shift with
Steering Clutches and Brakes**

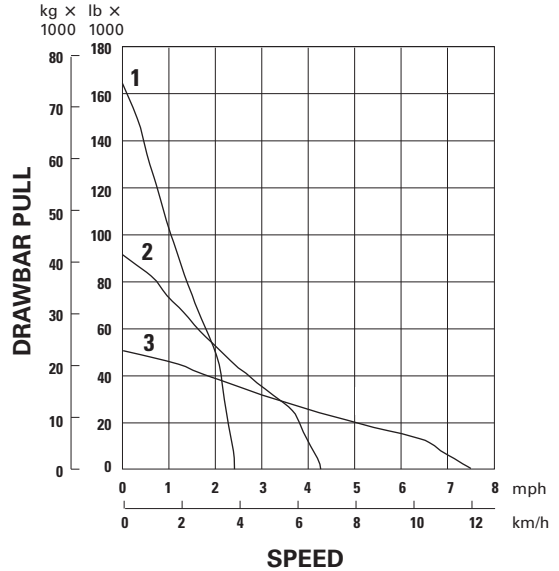

KEY

- 1 — 1st Gear
- 2 — 2nd Gear
- 3 — 3rd Gear

NOTE: Usable pull will depend upon weight and traction of equipped tractor.

D9T Differential Steering

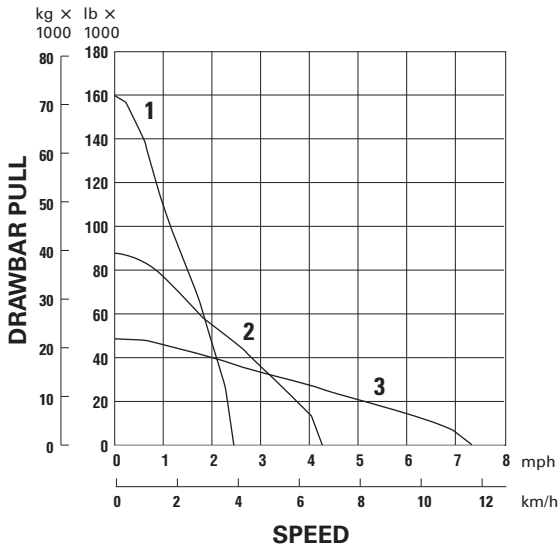

D10T2

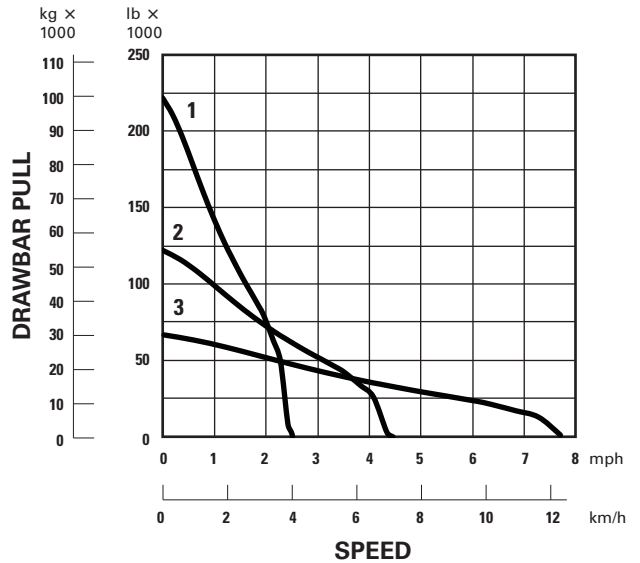

D11T/D11T CD

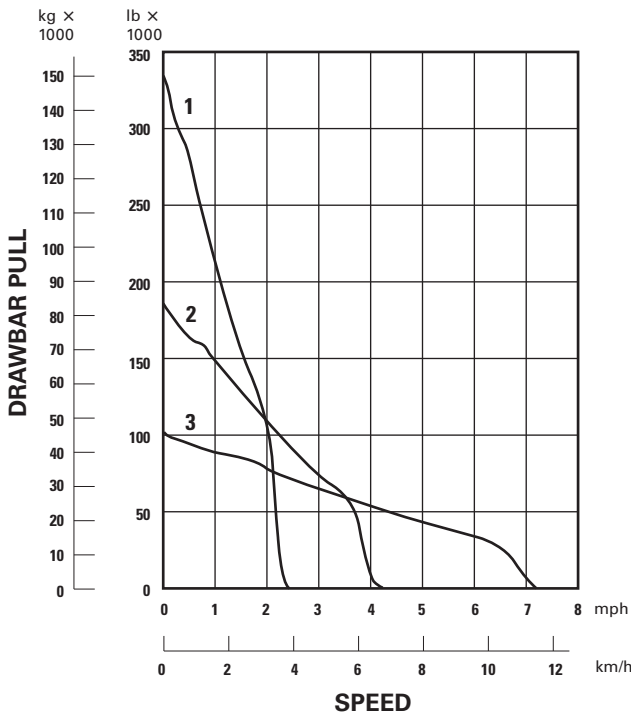

KEY

- 1 — 1st Gear
- 2 — 2nd Gear
- 3 — 3rd Gear

NOTE: Usable pull will depend upon weight and traction of equipped tractor. Tractors with suspended undercarriage can provide up to 15% more tractive effort than tractors with non-suspended undercarriage.

TRAVEL SPEED

POWER SHIFT MODEL	D3K2 ¹		D3K2		D4K2 ¹		D4K2		D5K2 ¹		D5K2		D6K2	
	All Models		All Models		All Models		All Models		All Models		All Models		All Models	
HYDROSTATIC	km/h	mph	km/h	mph	km/h	mph	km/h	mph	km/h	mph	km/h	mph	km/h	mph
FORWARD	9.0	5.6	9.0	5.6	9.0	5.6	9.0	5.6	9.0	5.6	9.0	5.6	10.0	6.2
REVERSE	10.0	6.2	10.0	6.2	10.0	6.2	10.0	6.2	10.0	6.2	10.0	6.2	10.0	6.2

¹ Meets Tier 3/Stage IIIA/Japan 2006 (Tier 3) equivalent emission standards.

POWER SHIFT MODEL	D5R2		D6R2		D6T		D7E		D7E LGP		D7R	
	Powershift with AutoShift		Powershift with AutoShift									
FORWARD	km/h	mph	km/h	mph	km/h	mph	km/h	mph	km/h	mph	km/h	mph
1	3.3	2.1	3.8	2.4	3.8	2.3	—	—	—	—	3.52	2.19
1.5	4.2	2.6	4.8	3.0	—	—	—	—	—	—	—	—
2	5.8	3.6	6.5	4.1	6.5	4.0	—	—	—	—	6.10	3.79
2.5	7.3	4.5	8.4	5.2	—	—	—	—	—	—	—	—
3	10.1	6.3	11.5	7.1	11.3	7.0	—	—	—	—	10.54	6.55
REVERSE												
1	4.2	2.6	4.8	3.0	4.7	2.9	—	—	—	—	4.54	2.82
1.5	5.2	3.2	6.2	3.9	—	—	—	—	—	—	—	—
2	7.3	4.5	8.4	5.2	8.3	5.1	—	—	—	—	7.85	4.88
2.5	7.3	4.5	8.4	5.2	—	—	—	—	—	—	—	—
3	12.5	7.8	14.5	9.1	14.6	9.0	—	—	—	—	13.58	8.44
ELECTRIC												
FORWARD	—	—	—	—	—	—	11.3	7.0	11.3	7.0	—	—
REVERSE	—	—	—	—	—	—	11.3	7.0	11.3	7.0	—	—

GEAR	D6N*			
	D6N* Powershift with AutoShift		D6N* Powershift with AutoShift – Sound Suppressed	
FORWARD	km/h	mph	km/h	mph
0.5	2.5	1.6	2.4	1.5
0.7	2.8	1.7	2.7	1.6
1.0	3.3	2.1	3.0	1.9
1.5	4.4	2.7	4.4	2.7
1.7	4.9	3.0	4.9	3.0
2.0	5.8	3.6	5.8	3.6
2.5	7.5	4.7	7.5	4.7
2.7	8.3	5.2	8.3	5.2
3.0	9.8	6.1	9.8	6.1
REVERSE				
0.5	3.1	1.9	2.9	1.8
0.7	3.4	2.1	3.1	1.9
1.0	4.1	2.5	3.5	2.2
1.5	5.4	3.4	5.4	3.4
1.7	6.0	3.7	6.0	3.7
2.0	7.1	4.4	7.1	4.4
2.5	9.5	5.9	9.5	5.9
2.7	10.5	6.5	10.5	6.5
	12.2	7.6	12.2	7.6

*Meets standards equivalent to Tier 4 Final/Stage IV/Japan 2014 (Tier 4 Final).

TRAVEL SPEED

POWER SHIFT MODEL	Differential Steer		D8T		D9R		D9T		D10T2		D11T/CD		D11T/CD High Altitude	
	km/h	mph	km/h	mph	km/h	mph	km/h	mph	km/h	mph	km/h	mph	km/h	mph
FORWARD														
1	3.5	2.2	3.4	2.1	3.8	2.4	3.9	2.4	4.0	2.5	3.9	2.4	4.0	2.5
2	6.2	3.9	6.0	3.7	6.8	4.2	6.8	4.2	7.2	4.5	6.8	4.2	7.0	4.4
3	10.8	6.7	10.6	6.6	11.9	7.4	11.7	7.3	12.7	7.9	11.8	7.3	12.0	7.5
REVERSE														
1	4.7	2.9	4.5	2.8	4.7	2.9	4.7	2.9	5.2	3.2	4.7	2.9	4.8	3.0
2	8.1	5.0	7.9	4.9	8.4	5.2	8.4	5.2	9.0	5.6	8.2	5.1	8.3	5.2
3	13.9	8.6	14.2	8.8	14.7	9.1	14.3	8.9	15.8	9.8	14.0	8.7	14.9	9.0

GEAR	D6T Powershift with AutoShift		D6T Powershift with AutoShift – Sound Suppressed	
	km/h	mph	km/h	mph
FORWARD				
0.5	2.7	1.7	2.7	1.7
0.7	3.3	2.0	3.2	2.0
1.0	3.7	2.3	3.2	2.0
1.5	4.7	2.9	4.7	2.9
1.7	5.7	3.6	5.7	3.6
2.0	6.5	4.0	6.3	3.9
2.5	8.2	5.1	8.2	5.1
2.7	10.0	6.2	10.0	6.2
3.0	11.3	7.0	10.9	6.8
REVERSE				
0.5	3.5	2.2	3.5	2.2
0.7	4.2	2.6	3.9	2.4
1.0	4.7	2.9	3.9	2.4
1.5	6.0	3.7	6.0	3.7
1.7	7.3	4.5	7.3	4.5
2.0	8.3	5.1	8.0	5.0
2.5	10.4	6.5	10.4	6.5
2.7	12.7	7.9	12.7	7.9
3.0	14.4	9.0	13.8	8.6

GROUND PRESSURES

Pressures computed from operating weights given earlier in this section in the specifications tables.

MODEL	SHOE WIDTH		CONTACT AREA		GROUND PRESSURE	
	mm	in	m ²	in ²	kPa	psi
D3K2 XL ¹	406	16	1.70	2637	44.80	6.50
D3K2 LGP ¹	635	25	2.70	4124	29.70	4.30
D3K2 XL	406	16	1.70	2637	44.80	6.50
D3K2 LGP	635	25	2.70	4124	29.70	4.30
D4K2 XL ¹	460	18	2.10	3206	38.60	5.60
D4K2 LGP ¹	635	25	2.90	4425	29.20	4.24
D4K2 XL	460	18	2.10	3206	38.60	5.60
D4K2 LGP	635	25	2.90	4425	29.20	4.24
D5K2 XL ¹	510	20	2.40	3652	39.10	5.67
D5K2 LGP ¹	660	26	3.00	4726	31.10	4.52
D5K2 XL	510	20	2.40	3652	39.10	5.67
D5K2 LGP	660	26	3.00	4726	31.10	4.52
D5R2 XL ¹	560	22	2.89	4480	57.69	8.20
	600	23.6	3.13	4806	53.27	7.65
	610	24	3.18	4929	52.43	7.46
D5R2 LGP ¹	840	33	5.24	8117	35.47	5.05
	865	34	5.39	8385	34.48	4.89
D5T ¹	560	22	2.89	4480	57.69	8.20
	600	23.6	3.13	4806	53.27	7.65
	610	24	3.18	4929	52.43	7.46
D6K2 XL	510	20	2.70	4185	46.82	6.79
(Standard shoe)	560	22	3.00	4650	42.13	6.11
D6K2 LGP	610	24	3.20	4960	41.30	5.99
(Standard shoe)	760	30	4.00	6200	33.02	4.79
D6N XL ²	610	24	3.18	4929	51.70	7.49
D6N LGP ²	840	33	5.22	8107	34.20	4.96

¹ Meets Tier 3/Stage IIIA/Japan 2006 (Tier 3) equivalent emission standards.

² Meets Tier 4 Interim/Stage IIIB/Japan 2011 (Tier 4 Interim) equivalent emission standards.

MODEL	SHOE WIDTH		CONTACT AREA		GROUND PRESSURE	
	mm	in	m ²	in ²	kPa	psi
D6R2 STD ¹	560	22	2.98	4625	62.40	9.05
	610	24	3.25	5038	57.28	8.31
D6R2 XL ¹	560	22	3.22	4984	60.70	8.80
	610	24	3.50	5429	55.72	8.08
D6R2 LGP ¹	915	36	5.99	9290	35.40	5.13
	1000	39.37	6.55	10,153	32.39	4.70
D6T XL ²	560	22	3.20	4922	64.82	9.40
	610	24	3.49	5369	59.43	8.62
D6T XW ²	610	24	3.48	5390	61.45	8.91
	710	28	4.06	6289	52.66	7.64
	760	30	4.35	6738	49.15	7.13
D6T LGP ²	760	30	4.98	7729	45.05	6.53
	915	36	5.98	9275	37.52	5.44
	991	39	6.48	10,048	34.65	5.02
D6T XL VPAT ²	560	22	3.20	4922	73.1	10.60
	610	24	3.49	5369	66.9	9.70
D6T XW VPAT ²	710	28	4.65	7214	51.0	7.40
D6T LGP VPAT ²	790	31	5.18	8034	46.2	6.70

¹ Meets Tier 2/Stage II/Japan 2001 (Tier 2) or Tier 3/Stage IIIA/Japan 2006 (Tier 3) equivalent emission standards.

² Meets Tier 4 Final/Stage IV/Japan 2014 (Tier 4 Final) emission standards.

NOTE: Ground contact area = width of track shoe
× length of track on ground × 2.

$$\text{Ground pressure} = \frac{\text{operating weight}}{\text{ground contact area}}$$

GROUND PRESSURES

Pressures computed from operating weights given earlier in this section in the specifications tables.

MODEL	SHOE WIDTH		CONTACT AREA		GROUND PRESSURE	
	mm	in	m ²	in ²	kPa	psi
D7E ¹	560	22	3.37	5231	75.71	10.98
	◀ 610	24	3.68	5698	69.51	10.08
	660	26	3.98	6165	64.24	9.32
D7E LGP ¹	915	36	6.31	9792	44.28	6.42
D7R	◀ 560	22	3.24	5016	75.10	10.56
	610	24	3.53	5472	69.00	9.76
D7R XR	◀ 560	22	3.43	5315	70.60	10.03
	610	24	3.75	5808	65.90	9.26
D7R LGP	914	36	5.82	9029	45.50	6.48
D8R	◀ 610	24	3.91	6062	95.11	13.79
	660	26	4.23	6559	87.90	12.75
	710	28	4.55	7056	81.48	11.81
D8R LGP	965	38	6.29	9746	54.88	7.96
D8T	◀ 610	24	3.91	6062	99.69	14.46
	660	26	4.23	6559	92.14	13.36
	710	28	4.55	7056	85.65	12.42
D8T LGP	965	38	6.19	9593	59.83	8.68
D8T ¹	610	24	3.91	6062	99.81	14.47
	660	26	4.23	6559	92.25	13.38
	710	28	4.55	7056	85.75	12.43
D8T LGP ¹	965	38	6.19	9593	59.90	8.68

◀ Standard shoe.

¹ Meets Tier 4 Interim/Stage IIIB/Japan 2011 (Tier 4 Interim) equivalent emission standards.

MODEL	SHOE WIDTH		CONTACT AREA		GROUND PRESSURE	
	mm	in	m ²	in ²	kPa	psi
D9R/D9T	560	22	3.89	6031	121.8	17.67
	◀ 610	24	4.24	6569	111.80	16.22
	685	27	4.74	7374	99.60	14.45
	760	30	5.28	8185	89.80	13.02
D10T2	◀ 610	24	4.74	7347	145.25	21.06
	710	28	5.52	8551	124.49	18.06
	760	30	5.91	9153	116.19	16.85
D11T	◀ 710	28	6.31	9781	161.98	23.49
	810	32	7.20	11,159	141.99	20.59
	915	36	8.13	12,605	125.69	18.23
D11T CD	◀ 810	32	7.20	11,159	153.54	22.27
	915	36	8.13	12,605	135.92	19.71

NOTE: Ground contact area = width of track shoe × length of track on ground × 2.

$$\text{Ground pressure} = \frac{\text{operating weight}}{\text{ground contact area}}$$

EXTREME SLOPE OPERATION

The maximum fore and aft grade in static condition on which each track-type tractor or pipelayer will maintain proper lubrication is 45 degrees (100%). Consult Operation & Maintenance Manual (if applicable) for POWER TRAIN fluid level overfill requirements for operation on extreme slopes. Extreme slope operation is anytime the slope exceeds 25° (47%).

When working sidehills and slopes, consideration should be given to the following important points:

- Speed of travel — At higher speeds, inertia forces tend to make the tractor less stable.
- Roughness of terrain or surface — Ample allowance should be made where the terrain or surface is uneven.
- Mounted equipment — Bulldozers, sidebooms, winches, and other mounted equipment cause the tractor to balance differently.
- Nature of surface — New earthen fills may give way with the weight of the tractor. Rocky surfaces may promote side slipping of tractor.
- Track slippage due to excessive loads — This may cause downhill track to “dig in,” increasing angle of tractor.

The ENGINE should never be overfilled with oil. This may lead to rapid overheating. For extreme slope operation, engine oil should be maintained at the full mark.

NOTE: Both ENGINE and POWER TRAIN fluid levels should be checked on level ground before working sidehills and slopes.

- Implements hitched to the drawbar — This may decrease weight on uphill track, e.g., logging arch, two-wheel wagon.
- Height of hitch on tractor — When a high drawbar is used the tractor is less stable than with the standard drawbar.
- Width of shoes — Wide track shoes tend to decrease “digging in”, hence tractor is more stable.
- Operated equipment — Be aware of the stability and other performance features of the equipment operated by the tractor.
- Keep all attachments or pulled loads low to the ground for optimum stability.

NOTE: Safe operation on steep slopes may require special machine maintenance as well as excellent operator skill and proper equipment for the specific application. Consult Operation & Maintenance Manual (if applicable) for proper fluid level requirements.

HYDRAULIC CONTROLS

CONTENTS

Features	19-29
Specifications	19-30

Features:

- **Designed and built for specific tractor applications.** Valves and components sized for exacting quality and performance.
- **Job requirements matched** through various arrangements.
- **Hydraulic blade and ripper controls:** Mechanical controls on G Series. Electro hydraulic controls on D6N and D6K2. Pilot blade and ripper controls on D6T Tier 3 with optional electro hydraulic blade control. Electro hydraulic blade and ripper controls on D6T Tier 4 Interim/Stage IIIB. Mechanical controls on D9R. Electro hydraulic blade and ripper controls on D7E, D8T, D9T, D10T2, and D11T.
- **Full flow filters***... all oil completely filtered.
- **Dual tilt** — standard on D11T and D11T CD, attachment option on D7E, D8R, D8T, D9R, D9T, D10T2.

*Exception — D8R 2-pump.

MODEL	D3K2		D3K2		D4K2		D4K2	
Mounting Point	Fender		Fender		Fender		Fender	
Number of Valves	3 or 4		3 or 4		3 or 4		3 or 4	
Flow at 6890 kPa (1000 psi)	73.5 L/min	19.4 gpm @ 2150 RPM	73.5 L/min	19.4 gpm @ 2150 RPM	73.5 L/min	19.4 gpm @ 2150 RPM	73.5 L/min	19.4 gpm @ 2150 RPM
Tank Capacity (Oil)	59.5 L	15.7 U.S. gal	59.5 L	15.7 U.S. gal	59.5 L	15.7 U.S. gal	59.5 L	15.7 U.S. gal
Lift Relief Valve Setting	20 600 kPa	2988 psi	20 600 kPa	2988 psi	20 600 kPa	2988 psi	20 600 kPa	2988 psi
Weight Installed:								
4 Valves	39 kg	86 lb*	39 kg	86 lb*	39 kg	86 lb*	39 kg	86 lb*

MODEL	D5K2		D5K2		D5R2/D5T	
Mounting Point	Fender		Fender		Under Operator's Platform	
Number of Valves	3 or 4		3 or 4		2, 3, or 4	
Flow at 6890 kPa (1000 psi)	73.5 L/min	19.4 gpm @ 2150 RPM	73.5 L/min	19.4 gpm @ 2150 RPM	135 L/min	35.7 gpm @ 2200 RPM
Tank Capacity (Oil)	59.5 L	15.7 U.S. gal	59.5 L	15.7 U.S. gal	29.5 L	7.8 U.S. gal
Lift Relief Valve Setting	20 600 kPa	2988 psi	20 600 kPa	2988 psi	26 500 kPa	3843 psi
Weight Installed:						
2 Valves	—		—		27.26 kg	60.1 lb
3 Valves	—		—		31.25 kg	68.9 lb
4 Valves	39 kg	86 lb*	39 kg	86 lb*	36.19 kg	79.8 lb

MODEL	D6K2		D6N ¹		D6R2 ³		D6R2 ⁴	
Mounting Point	Under Operator's Platform		Right Rear Fender		Under Operator's Platform		Under Operator's Platform	
Number of Valves	3 or 4		3 or 4		2 or 3		2 or 3	
Flow at 6890 kPa (1000 psi)	120 L/min	31.7 gpm @ 2100 RPM	132.5 L/min	35.0 gpm @ 2300 RPM	203 L/min	53.6 gpm @ 2120 RPM	188 L/min	49.7 gpm @ 1961 RPM
Tank Capacity (Oil)	58 L	15.3 U.S. gal	29.5 L	7.8 U.S. gal	51.5 L	13.6 U.S. gal	51.5 L	13.6 U.S. gal
Lift Relief Valve Setting	—		—		19 300 kPa	2799 psi	19 300 kPa	2799 psi
XL and LGP	26 000 kPa	3771 psi	27 500 kPa	3989 psi	—		—	
Weight Installed:								
2 Valves	—		—		61.33 kg	135.2 lb	61.33 kg	135.2 lb
3 Valves	30 kg	66 lb	27 kg	59.5 lb	77.83 kg	171.6 lb	77.83 kg	171.6 lb
4 Valves	37 kg	81.6 lb	32 kg	70.5 lb	—		—	

MODEL	D6T		D6T ²		D6T VPAT ²		D7E (Differential Steer)	
Mounting Point	Under Operator's Platform		Under Operator's Platform		Under Operator's Platform		Blade Control under Hood, Ripper on Rear	
Number of Valves	2, 3, or 4		2, 3, or 4		3 or 4		2 Std. 4 with Ripper	
Flow at 6890 kPa (1000 psi)	205 L/min	54 gpm @ 2010 RPM	205 L/min	54 gpm @ 2010 RPM	205 L/min	54 gpm @ 2010 RPM	204 L/min	54 gpm @ 2124 RPM (PMP)
Tank Capacity (Oil)	47.3 L	12.5 U.S. gal	96 L	25.4 U.S. gal	96 L	25.4 U.S. gal	66 L	17.4 U.S. gal
Lift Relief Valve Setting	19 300 kPa	2800 psi	19 300 kPa	2800 psi	21 550 kPa	3125 psi	27 600 kPa	4000 psi
Weight Installed:								
2 Valves	Included in Std. Tractor		Included in Std. Tractor		—		Included in Std. Tractor	
3 Valves	—		—		Included in Std. Tractor		—	

*Hydraulic tank not included.

¹ Meets Tier 4 Final/Stage IV/Japan 2014 (Tier 4 Final) emission standards.

² Meets Tier 4 Interim/Stage IIIB/Japan 2011 (Tier 4 Interim) equivalent emission standards.

³ Meets Tier 2/Stage II/Japan 2001 (Tier 2) equivalent emission standards.

⁴ Meets Tier 3/Stage IIIA/Japan 2006 (Tier 3) equivalent emission standards.

NOTE: Weight installed, two valves, includes pump, tank with filters, valves, lines, linkage, oil cooler and control levers.

MODEL	D7R (Differential Steer)	D8R	D8T	D9R
Mounting Point	Under Operator's Platform	Under Operator's Platform	At Rear Center of Fuel Tank	Under Operator's Platform
Number of Valves	3 or 5	2 Std. 4 with Ripper◀ Pilot Control System	2 Std., 3 with Winch, 4 with Ripper, 5 with Implement Towing AR Electro/Hydraulic Control System	4 + Dual Tilt (Attach.) Radiator Guard Mechanical Control System
Flow at 6890 kPa (1000 psi)	289 L/min 76 gpm @ 2100 RPM	240 L/min 63 gpm @ 2100 RPM (PMP)	282 L/min 74.5 gpm @ 2200 RPM	239 L/min 63 gpm @ 1900 RPM
Tank Capacity (Oil)	54 L 14.3 U.S. gal	72 L 19 U.S. gal	75 L 19.8 U.S. gal	77.2 L 20.4 U.S. gal
Lift Relief Valve Setting	22 750 kPa 3300 psi	24 100 kPa 3500 psi	24 000 kPa 3481 psi	26 200 kPa 3800 psi
Weight Installed	358 kg 784 lb (Two Valves)	Included in Std. Tractor (Two Valves)	Included in Std. Tractor	Included in Std. Tractor (Two Valves)
MODEL	D9T	D10T2	D11T	D11T CD
Mounting Point	Under Operator's Platform	Under Operator's Platform	Under Operator's Platform	Under Operator's Platform
Number of Valves	4 + Dual Tilt (Attach.) Electro/Hydraulic Control System	5 Single Tilt 6 Dual Tilt	4 At Rear Under Fuel Tank 1◀ + Dual Tilt Standard Radiator Guard	4 At Rear Under Fuel Tank 1◀ Dual Tilt Standard Quick Dump Valve Standard Both on Radiator Guard
Flow at 6890 kPa (1000 psi)	258 L/min 68 gpm @ 2010 RPM	380 L/min 100.4 gpm @ 1800 RPM	620 L/min 164 gpm @ 1800 RPM	670 L/min 177 gpm @ 1800 RPM
Tank Capacity (Oil)	89 L 23.5 U.S. gal	131 L 34.6 U.S. gal	223 L 58.9 U.S. gal	223 L 58.9 U.S. gal
Lift Relief Valve Setting	26 200 kPa 3800 psi	—	—	—
Lift	—	28 000 kPa 4061 psi	22 753 kPa 3300 psi	24 132 kPa 3500 psi
Tilt	—	20 300 kPa 2944 psi	24 304 kPa 3525 psi	24 821 kPa 3600 psi
Weight Installed	Included in Std. Tractor	Included in Std. Tractor (Six Valves)	Included in Std. Tractor	Included in Std. Tractor

◀Ripper valve.

NOTE: Weight installed, two valves, includes pump, tank with filters, valves, lines, linkage, oil cooler and control levers.

BULLDOZERS

CONTENTS

Features	19-33
Summary of Blade Options.....	19-34
Blade Selection	19-36
General Dimensions (Tractor and Blade).....	19-39
SAE Blade Capacity Definition	19-39
Blade Specifications.....	19-40
Estimating Production Off-the-Job.....	19-50
Job Condition Correction Factors	19-55
Measuring Production On-the-Job.....	19-56
Attachments.....	19-56
Special Attachments	19-57

Features:

- **Straight Bulldozers** — adjustable tilt angle controls blade penetration.
- **Variable cutting edge Power Angle and Tilt (VPAT)** — blade is available on the D3K2, D4K2, D5K2, D6K2, D6N, and D6T. The blade can be mechanically tipped forward for improved penetration or back for more productivity and easier finish grading.
- **Angling Bulldozers** — 25° right/left angling; C-frame allows mounting other tools.
- **Universal Bulldozers** — 25° wings provide increased capacity, less spillage.
- **Semi-Universal Bulldozers** — combines penetration ability of straight blade with increased load capacity provided by short 25° wings.
- **Wheel Dozer blades** are offered in straight and universal blade design with hydraulic pitch and tilt control.
- **Box-section construction** on blades adds rigidity and strength.
- **Cutting edges** are heat treated and reversible for extra life.

MODEL	CAT BLADES										SPECIAL BLADES											
	S	U	SU	A	FS	LFS	VP	CD	RC	WC	CL	HU	LF	TW	CU	CPB	CB	VR	WCB	CS	WCS	W
D3K2 XL ²							●															
D3K2 LGP ²							●															
D3K2 XL							●															
D3K2 LGP							●															
D4K2 XL ²							●															
D4K2 LGP ²							●															
D4K2 XL							●															
D4K2 LGP							●															
D5K2 XL ²							●															
D5K2 LGP ²							●															
D5K2 XL							●															
D5K2 LGP							●															
D5E				●																		
D5R2 XL			●	●			●						●									
D5R2 LGP	●						●						●									
D5T XL		●					●						●									
D6K2 XL							●															
D6K2 LGP							●															
D6N XL ¹			●				●						●									
D6N LGP ¹							●						●									
D6R	●		●	●																		
D6R XL			●	●									●									
D6R LGP	●												●									
D6R2	●		●	●																		
D6R2 XL			●	●									●									
D6R2 LGP	●												●									
D6R Series 3	●		●	●						●	●		●					●				
D6R Series 3 XL			●	●			●															
D6R Series 3 LGP	●						●			●	●		●						●			
D6R Series 3 XW			●	●			●															
D6T XL			●	●			●			●			●						●			
D6T LGP	●			●			●			●	●		●						●			
D6T XW			●	●			●			●			●									

¹ Meets Tier 4 Final/Stage IV/Japan 2014 (Tier 4 Final) emission standards.
² Meets Tier 3/Stage IIIA/Japan 2006 (Tier 3) equivalent emission standards.

CATERPILLAR SUPPLIED

- S – Straight
- U – Universal
- SU – Semi-Universal
- A – Angling
- FS – Fill Spreading
- LFS – Landfill Spreading
- VP – Variable Pitch, Lower, Angle and Tilt (VPAT)

SPECIAL SUPPLIED

- RC – Reclamation U
- WC – Woodchips
- CL – Coal
- HU – Heavy U
- LF – Landfill
- CD – Carry Dozer
- TW – Two-Way Dozer
- CU – Cushion Dozer
- CPB – Cushion Push Block
- CB – Coal Bowldozer
- VR – Variable Radius
- WCB – Wood Chip Bowldozer
- CS – Coal Scoop
- WCS – Wood Chip Scoop
- W – W-Blade

NOTE: This chart suggests a range of blade options for Caterpillar built machines. It is not totally inclusive of all blades available.

MODEL	CAT BLADES									SPECIAL BLADES													
	S	U	SU	A	FS	LFS	VP	CD	RC	WC	CL	HU	LF	TW	CU	CPB	CB	VR	WCB	CS	WCS	W	
D7E	●	●	●	●						●													
D7E LGP	●									●													
D7R			●	●									●										
D7R XR			●	●									●										
D7R LGP	●												●										
D7R Series 2	●	●	●	●						●	●		●	●					●				
D7R Series 2 LGP	●												●						●				
D7G Series 2	●		●	●																			
D8R		●	●	●					●	●	●		●		●	●			●				
D8R LGP		●	●										●										
D8T		●	●	●					●	●	●		●		●				●				
D8T LGP		●	●										●										
D9R/D9T		●	●						●	●	●		●		●	●	●			●			
D10T2		●	●						●	●	●		●		●	●	●						
D11T		●	●						●		●												
D11T CD								●															
814F	●										●	●								●	●		
815F					●																		
816F						●							●										●
824G/824H	●									●	●	●										●	
825G					●																		
826G/826H						●							●										●
834G/834H	●	●								●	●									●	●		
836G/836H													●										●

CATERPILLAR SUPPLIED

- S – Straight
- U – Universal
- SU – Semi-Universal
- A – Angling
- FS – Fill Spreading
- LFS – Landfill Spreading
- VP – Variable Pitch, Lower, Angle and Tilt (VPAT)

SPECIAL SUPPLIED

- RC – Reclamation U
- WC – Woodchips
- CL – Coal
- HU – Heavy U
- LF – Landfill
- CD – CarryDozer
- TW – Two-Way Dozer
- CU – Cushion Dozer
- CPB – Cushion Push Block
- CB – Coal Bowl Dozer
- VR – Variable Radius
- WCB – Wood Chip Bowl Dozer
- CS – Coal Scoop
- WCS – Wood Chip Scoop
- W – W-Blade

NOTE: This chart suggests a range of blade options for Caterpillar built machines. It is not totally inclusive of all blades available.

BLADE SELECTION

Properly matching tractor and dozer is a basic requirement for maximizing production. First consider the kind of work the tractor will be doing most of its life. Then evaluate:

- Material to be moved.
- Tractor limitations.

Materials to be moved

Most materials are dozeable. However, dozer performance will vary with material characteristics such as:

Particle Size and Shape — The larger the individual particle size, the harder it is for a cutting edge to penetrate. Particles with sharp edges resist the natural rolling action of a dozer blade. These particles require more horsepower to move than a similar volume of material with rounded edges.

Voids — Few voids or the absence of voids means the individual particles have most or all of their surface area in contact with other particles. This forms a bond which must be broken. A well graded material, which lacks voids, is generally heavy, and will be hard to remove from the bank state.

Water Content — In most materials the lack of moisture increases the bond between particles and makes the material difficult to remove from the bank state. A high moisture content makes dozing difficult because the material is heavy and requires more force to move. Optimum moisture reduces dust and offers the best condition for dozing ease and operator comfort.

The effect of freezing depends on the moisture content. When frozen, the material's bond strengthens as moisture content increases and temperature decreases. However, freezing a completely dry material does not change its characteristics.

An indication of a blade's ability to penetrate and obtain a blade load is kW per meter (or horsepower per foot) of cutting edge. The higher the kW/meter (HP/foot), the more aggressive the blade. Kilowatt per Lm^3 (horsepower per loose cubic yard) indicates a blade's ability to push material. The higher the kW/ Lm^3 (HP/LCY), the greater the blade's potential capability for carrying material at a greater speed.

Tractor Limitations

The weight and horsepower of the machine determines its ability to push. No tractor can exert more pounds push than the machine itself weighs and its power train can develop. Various terrain and underfoot conditions on the job limit the tractor's ability to use its weight and horsepower. The "approximate coefficient of traction factors" chart in the Tables Section presents these traction factors for common materials. To use the chart, take the total tractor weight (with attachments) times the factor to arrive at the maximum usable push the dozer can exert.

Production Dozing Tools

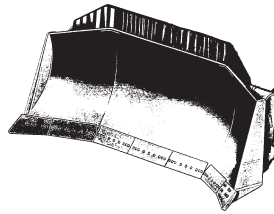

"U" — Universal blade — the large wings on this blade include one end bit and at least one section of cutting edge which make it efficient for moving big loads over long distances as in land reclamation, stockpile work, charging hoppers and trapping for loaders.

As this blade has a lower kW/meter (HP/foot) of cutting edge than an "S" or "SU", penetration should not be a prime objective. With a lower kW/ Lm^3 (HP/LCY) than an "S" or "SU", this blade is best for lighter or relatively easily dozed material. If equipped with tilt cylinders the U blade can be used to pry out, level, cut ditches and steer the tractor.

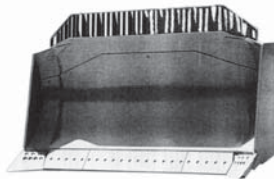

"SU" — The Semi-U blade combines the desirable characteristics of S and U-blades into one package. It has increased capacity by the addition of short wings which include only the dozer end bits. The

wings provide improved load retention capabilities while maintaining the blade's ability to penetrate and load quickly in tightly packed materials and to handle a wide variety of materials in production oriented applications. Tilt cylinder(s) increase both the productivity and versatility of this dozer. Equipped with a push plate, it is effectively used for push loading scrapers.

- General Purpose Dozing Tools
- Special Application Dozing Tools

Blade Selection

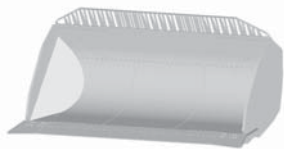

“CD” — The CD or Carry-Dozer Blade is available for the D11T CarryDozer only. It is built to the same high standard of structural integrity as the “U” and “SU” Dozers. The CD Blade has

a unique “bucket” shape that allows it to carry several cubic yards or cubic meters of material in the blade. This acts as a disposable counterweight that allows the CarryDozer to push more material per pass than a standard D11T. The CarryDozer will not be as effective as the “U” or “SU” dozer in tightly packed or poorly shot material. It is also more sensitive to the carry-back in sticky materials.

General Purpose Dozing Tools

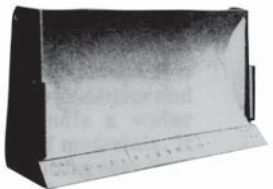

“S” — The Straight blade provides excellent versatility. Since it is physically smaller than the SU or U-blade, it is easier to maneuver and can handle a wider range of materials. It has a higher kW/meter (HP/foot)

of cutting edge than the SU or U-blade; consequently, the “S” is more aggressive in penetrating and obtaining a blade load. A tilt cylinder increases both the productivity and versatility of this dozer. With a high kW/Lm³ (HP/LCY), the S-blade can handle heavy material easily.



Power Angle and Tilt Blade — Versatility is its key feature with its ability to perform a variety of site development to general dozing work as well as heavy-duty applications.

Angle and tilt control is with 2 levers on some machines, 1 lever on others.

Variable Power Angle and Tilt (VPAT) blade can be mechanically tipped forward for improved penetration or shedding sticky material and backward for finish grading and improved productivity.

Special Application Dozing Tools

Caterpillar provides specialty bulldozers for specific applications. The blades are designed to increase production while performing certain tasks. Following are the most popular special applications blades.

Variable Radius (VR) Blades

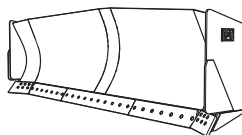

Variable Radius Semi-U Blades are excellent tools for land improvement, soil conservation, site development or general construction. They combine the

penetration ability of a Semi-U Blade with the load retention and high capacity of a U-blade.

They provide the aggressive cutting action needed for digging, while having the material retention characteristics needed for moving high volumes over a distance. This is accomplished through a moldboard which varies in radius from the edge to the center. This creates a rolling action in the material being moved, pushing it to the center of the blade for better retention. The extended side wings, angled to thirty degrees, further increase the capacity over a standard blade.

Angle Blade (A-Blade)



“A” — Or Angling blade can be positioned straight or angled 25 degrees to either side. It is designed for side-casting, pioneering roads,

backfilling, cutting ditches and other similar tasks. It can reduce the amount of maneuvering required to do these jobs. Its “C” frame can be used for attachments such as pushing, land clearing, or snow removal tools. A-blades are not recommended for rock or severe applications.

Cushion Dozers

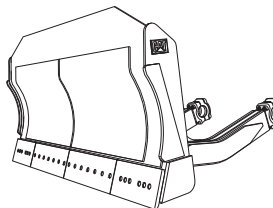

Cushion Dozers are designed to push-load wheel-tractor scrapers, or track-type tractors. The heavy-duty design includes reinforcement to transfer machine power without damaging the blade or the

tractor. Blade cylinders are pinned to the C-frame, and the blade height is such that the blade lift cylinders are isolated from damaging forces.

The taller blade allows pushing from a higher position, eliminating blade drag and increasing productivity. The blade curvature is matched to the curve of the Cat Push Block for maximum contact area, preventing the block from riding over the top of the blade. Extended side plates make it easier for operators to “catch” the stinger when repositioning for a new pass. The center of the blade is armored with T-1 plate steel for maximum service life. The narrow width of the cushion blade increases machine maneuverability in congested cuts and reduces the possibility of cutting tires associated with SU and U-blades.

When not push-loading, the dozer can be used for cut maintenance and other general dozing jobs.

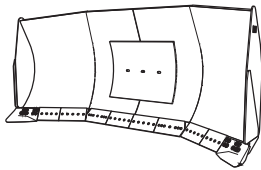

Coal U-Blades are designed specifically to move large volumes of coal in coal piles, at powerplants and transshipment points. The wing angle of thirty degrees crowds material to the center of the

blade, maximizing capacity by minimizing side spill. The moldboard is much higher and wider than standard, specifically to match the material density and loading characteristics of coal. The curve of the moldboard rolls the material forward, enhancing the carrying capacity. With this design, coal-moving capacity can be as much as 200 percent greater than a standard U-blade.

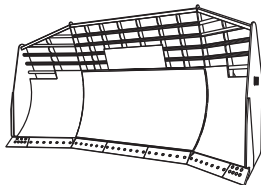

Landfill U-Blades provide capacity increases of up to fifty percent over a straight blade. Landfill blades have the height and width to handle large volumes of low-density refuse, but are tough

enough to dig and bulldoze ground cover. Vision to the load is provided by areas of screen in the upper blade. Angled wings slice into natural bed earth for trenches or cover material, adding to the versatility in the landfill.

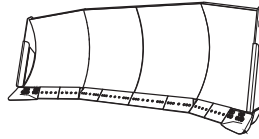

Reclamation U-Blades — are purpose-built for reclamation of mine spoil piles. The blade has a larger capacity than a standard U-blade.

The wing angle of 28 degrees provides a good balance between load retention and shearing action, keeping the optimal load in front of the blade, but cutting cleanly through the material when necessary.

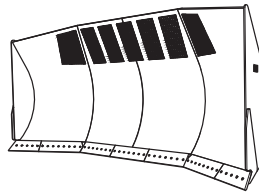

The width of **Woodchip U-Blades** gives operators maximum control and greater confidence, even in steep chip piles. Deep curvature of the moldboard keeps material flowing to live dead chips and optimize production on

long pushes. Blade height and wings angled at thirty degrees combine for excellent material retention – giving better production with every pass. An operator visibility window in the top section is standard.

Multi-Application/Rock and Root Rakes

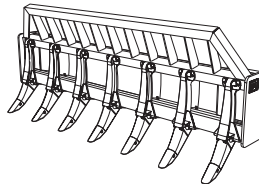

Multi-Application/Rock and Root Rakes are perfectly suited for heavy duty land clearing including removal of stumps, large rocks or large trees and for work in clay and other heavy soils.

Frames are constructed of high strength steel for longer life. Cast teeth, with replaceable tips, are designed for maximum ground penetration and resistance to shock loading when prying or pushing trees, stumps and rocks. Brush rack is standard and increases height and capacity by as much as 40%.

Rake is a direct replacement for existing blade, and utilizes existing push arms and C-frames.

- Tractor and Blade
- SAE Blade Capacity Definition

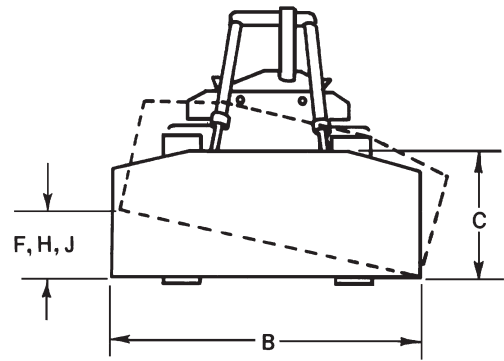
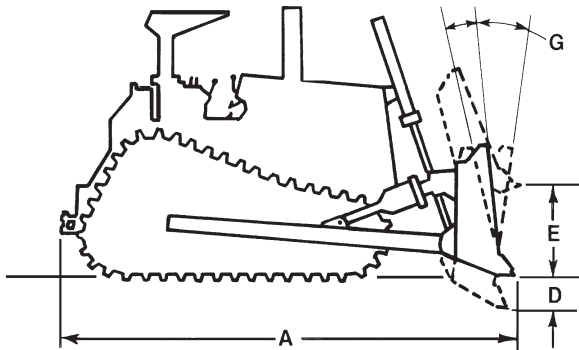

KEY

- A** Length (Blade Straight)
Blade:
- B** Width (including standard end bits)
- C** Height
- D** Maximum Digging Depth
- E** Ground Clearance @ Full Lift
- F** Maximum Tilt (Manual)
- G** Maximum Pitch Adjustment
- H** Maximum Hydraulic Tilt
- J** Hydraulic Tilt (manual brace centered)
- K** Push Arm Trunnion Width (to Ball Centers)

Blade capacities on the following pages are as determined by SAE recommended practice J1265. Capacities are defined as:

$$V_s = 0.8 WH^2$$

$$V_u = ZH(W-Z) \tan X$$

Where: V_s = Capacity of straight or angling blade.

V_u = Capacity of semi-U or full U-blade.

W = Blade width exclusive of end bits.

H = Effective blade height considering tapered top corners, etc.

Z = Wing length measured parallel to blade width @ ground line of cutting edges.

X = Wing angle.

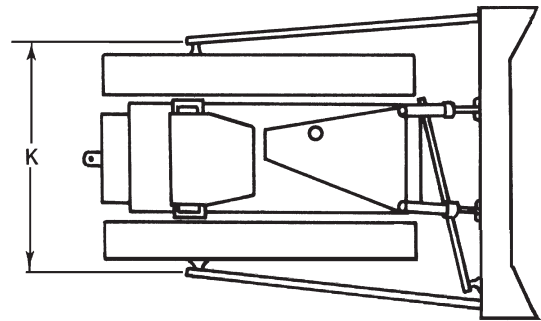

MODEL	D3K2***				D4K2***			
	XL		LGP		XL		LGP	
Type	Variable Power Angling and Tilt		Variable Power Angling and Tilt		Variable Power Angling and Tilt		Variable Power Angling and Tilt	
Blade Capacities*	1.52 m ³	1.99 yd ³	1.66 m ³	2.17 yd ³	1.98 m ³	2.59 yd ³	1.85 m ³	2.42 yd ³
Weight Shipping** (Dozer)	572 kg	1261 lb	630 kg	1389 lb	642 kg	1415 lb	661 kg	1457 lb
Tractor and Dozer Dimensions:								
A Length (Blade Straight)	4266 mm	168.0"	4255 mm	167.6"	4274 mm	168.3"	4266 mm	168.0"
Length (Blade Angled)	4763 mm	187.5"	4854 mm	191.1"	4795 mm	188.8"	4873 mm	191.8"
Width (Blade Angled)	2417 mm	95.1"	2874 mm	113"	2542 mm	100"	2874 mm	113"
Blade Dimensions:								
B Width (including std. end bits)	2646 mm	104.1"	3149 mm	124.0"	2782 mm	109.5"	3149 mm	124.0"
C Height	910 mm	35.8"	860 mm	33.8"	1010 mm	39.8"	910 mm	35.8"
D Max. Digging Depth	573 mm	22.5"	573 mm	22.5"	572 mm	22.5"	590 mm	23.2"
E Ground Clearance @ Full Lift	730 mm	28.7"	730 mm	28.7"	743 mm	29.3"	708 mm	27.9"
G Max. Pitch Adjustment	52° to 58°		52° to 58°		52° to 58°		52° to 58°	
J Hydraulic Tilt	368 mm	14.4"	438 mm	17.2"	387 mm	15.2"	438 mm	17.2"
Blade Angle	25°		25°		25°		25°	

MODEL	D5K2***			
	XL		LGP	
Type	Variable Power Angling and Tilt		Variable Power Angling and Tilt	
Blade Capacities*	2.19 m ³	2.86 yd ³	2.34 m ³	3.06 yd ³
Weight Shipping** (Dozer)	706 kg	1556 lb	728 kg	1605 lb
Tractor and Dozer Dimensions:				
A Length (Blade Straight)	4321 mm	170.1"	4294 mm	169.1"
Length (Blade Angled)	4864 mm	191.5"	4908 mm	193.2"
Width (Blade Angled)	2636 mm	103.8"	2940 mm	115.8"
Blade Dimensions:				
B Width (including std. end bits)	2782 mm	109.5"	3220 mm	126.7"
C Height	1050 mm	41.3"	1010 mm	39.8"
D Max. Digging Depth	586 mm	23.1"	572 mm	22.5"
E Ground Clearance @ Full Lift	767 mm	30.2"	767 mm	30.2"
G Max. Pitch Adjustment	52° to 58°		52° to 58°	
J Hydraulic Tilt	402 mm	15.8"	448 mm	17.6"
Blade Angle	25°		25°	

*Blade capacities as determined by SAE J1265.

**Shipping Weight – Total Bulldozer Arrangement includes: Blade, push arms or C-frame, braces, cylinders, lines, trunnions and lift cylinder mountings.

***Meets Tier 3/Stage IIIA/Japan 2006 (Tier 3) equivalent emission standards.

MODEL	D5R2 XL					
	ANGLE		SU		VPAT XL	
Type	Angle Blade		Semi-Universal		Variable Pitch Power Angle and Tilt	
Blade Capacities*	3.18 m ³	4.16 yd ³	4.28 m ³	5.6 yd ³	3.31 m ³	4.33 yd ³
Weight Shipping** (Dozer)	2546 kg	5612 lb	2600 kg	5732 lb	2375 kg	5236 lb
Tractor and Dozer Dimensions:						
A Length (Blade Straight)	5193 mm	17.04'	5157 mm	16'11"	5035 mm	16'6.2"
Length (Blade Angled)	6011 mm	19.72'	—	—	5680 mm	18'7.6"
Width (Blade Angled)	3785 mm	12.42'	—	—	2990 mm	9.9.7"
Width (with C-Frame only)	2918 mm	9.57'	—	—	2500 mm	8'2.4"
Blade Dimensions:						
	(outside mounted)		(outside mounted)		(inside mounted)	
B Width (including std. end bits)	4165 mm	13.66'	3154 mm	10'4.2"	3272 mm	10'8.8"
C Height	1034 mm	3.39'	1244 mm	4'1"	1195 mm	3'11"
D Max. Digging Depth	534 mm	1.75'	520 mm	1'8.5"	420 mm	1'4.5"
E Ground Clearance @ Full Lift	1098 mm	3.60'	983 mm	3'2.7"	1067 mm	3'6"
G Max. Pitch Adjustment	—	—	±5°	—	55.7° to 62.5°	
J Hydraulic Tilt	—	—	665 mm	2'2.2"	485 mm	1'7.1"
Blade Angle	25°		—	—	24.1°	

MODEL	D5R2 LGP		D6K2 XL		D6K2 LGP	
	VPAT LGP		VPAT XL		VPAT LGP	
Type	Variable Pitch Power Angle and Tilt		Variable Pitch Power Angle and Tilt		Variable Pitch Power Angle and Tilt	
Blade Capacities*	3.87 m ³	5.06 yd ³	3.07 m ³	4.01 yd ³	3.35 m ³	4.38 yd ³
Weight Shipping** (Dozer)	2740 kg	6041 lb	—	—	—	—
Tractor and Dozer Dimensions:						
A Length (Blade Straight)***	5398 mm	17'8.5"	5008 mm	197"	5008 mm	197"
Length (Blade Angled)	6083 mm	19'11.5"	5369 mm	211"	5399 mm	212"
Width (Blade Angled)	3727 mm	12'2.7"	2878 mm	113.3"	3337 mm	131.4"
Width (with C-Frame only)	3000 mm	9'10.1"	2330 mm	92"	2760 mm	109"
Blade Dimensions:						
	(inside mounted)		(inside mounted)		(inside mounted)	
B Width (including std. end bits)	4082 mm	13'4.7"	3196 mm	10'6"	3682 mm	12'0"
C Height	1040 mm	3'4.9"	1294 mm	50.9"	1294 mm	50.9"
D Max. Digging Depth	500 mm	1'7.7"	468 mm	18.4"	468 mm	18.4"
E Ground Clearance @ Full Lift	1052 mm	3'5.4"	1203 mm	3'10.8"	1201 mm	3'11.3"
G Max. Pitch Adjustment	54° to 62°		6°	—	6°	
H Max. Hydraulic Tilt	585 mm	1'11"	488 mm	1'7.2"	525 mm	1'8.4"
Blade Angle	24.1°		25°	—	25°	

*Blade capacities as determined by SAE J1265.

Notice that the capacity of the SU-blade is the volume carried by a straight blade of the same dimensions plus the volume included in the "cup" of the SU-blade. It is intended for relative comparisons of dozer sizes, and not for predicting capacities or productivities in actual field conditions.

**Shipping Weight — Total Bulldozer Arrangement includes: Blade, push arms or C-frame, braces, cylinders, lines, trunnions and lift cylinder mountings.

***With rear drawbar.

MODEL	D6N XL***				D6N LGP***	
	6SU		6VPAT XL		6VPAT LGP	
Type	Semi-Universal		Variable Pitch Power Angle and Tilt		Variable Pitch Power Angle and Tilt	
Blade Capacities*	4.28 m ³	5.6 yd ³	3.31 m ³	4.33 yd ³	3.87 m ³	5.06 yd ³
Weight, Shipping** (Dozer)	2600 kg	5732 lb	2375 kg	5236 lb	2740 kg	6041 lb
Tractor and Dozer Dimensions:						
A Length (Blade Straight)	5157 mm	16'11"	5035 mm	16'6.2"	5398 mm	17'8.5"
Length (Blade Angled)	—	—	5680 mm	18'7.6"	6243 mm	20'5.8"
Width (Blade Angled)	—	—	2965 mm	116.7"	3699 mm	145.6"
Width (with C-Frame only)	—	—	2545 mm	100"	2965 mm	116.7"
Blade Dimensions:						
	(outside mounted)		(inside mounted)		(inside mounted)	
B Width (including std. end bits)	3154 mm	10'4.2"	3272 mm	10'8.8"	4082 mm	13'4.7"
C Height	1244 mm	4'1"	1195 mm	3'11"	1040 mm	3'4.9"
D Max. Digging Depth	520 mm	1'8.5"	420 mm	1'4.5"	500 mm	1'7.7"
E Ground Clearance @ Full Lift	983 mm	3'2.7"	1067 mm	3'6"	1052 mm	3'5.4"
G Max. Pitch Adjustment	±5°		55.7° to 62.5°		54° to 62°	
H Max. Hydraulic Tilt	665 mm	2'2.2"	485 mm	1'7.1"	585 mm	1'11"
Blade Angle	—		25°		25°	

MODEL	D6R			
	6A		6A XL	
Gauge	1.88 m	74"	1.88 m	74"
Type	Angling		Angling	
Blade Capacities*	3.94 m ³	5.15 yd ³	3.94 m ³	5.15 yd ³
Weight, Shipping** (Dozer)	3195 kg	7044 lb	3195 kg	7044 lb
Tractor and Dozer Dimensions:				
A Length (Blade Straight)	5.00 m	17'1"	5.21 m	17'1"
Length (Blade Angled)	5.83 m	19'2"	6.05 m	19'10"
Width (Blade Angled)	3.77 m	12'5"	3.77 m	12'5"
Width (with C-Frame only)	2.99 m	9'10"	2.99 m	9'10"
Blade Dimensions:				
B Width (including std. end bits)	4.16 m	13'8"	4.16 m	13'8"
C Height	1154 mm	3'10"	1154 mm	3'10"
D Max. Digging Depth	511 mm	1'8"	511 mm	1'8"
E Ground Clearance @ Full Lift	1217 mm	4'0"	1217 mm	4'0"
F Manual Tilt	—		—	
H Max. Hydraulic Tilt	485 mm	1'4"	485 mm	1'4"
Blade Angle	25°		25°	
K Push Arm Trunnion Width (to Ball Centers)	2.58 m	8'6"	2.58 m	8'6"

*Blade capacities as determined by SAE J1265. Tractor and dozer dimensions variations due to SystemOne undercarriage products are negligible. Notice that the capacity of the SU-blade is the volume carried by a straight blade of the same dimensions plus the volume included in the "cup" of the SU-blade. It is intended for **relative comparisons of dozer sizes**, and not for predicting capacities or productivities in actual field conditions.
 **Shipping Weight — Total Bulldozer Arrangement includes: Blade, push arms or C-frame, braces, cylinders, lines, trunnions and lift cylinder mountings.
 ***Meets standards equivalent to U.S. EPA Tier 4 Final/EU Stage IV/Japan 2014 (Tier 4 Final).

MODEL	D6R2							
	6S		6SU		6SU XL		6S LGP	
Gauge	—		1880 mm	74"	1880 mm	74"	2286 mm	90"
Type	Straight		Semi-Universal		Semi-Universal		Straight	
Blade Capacities*	3.89 m ³	5.1 yd ³	5.61 m ³	7.3 yd ³	5.55 m ³	7.26 yd ³	3.75 m ³	4.9 yd ³
Weight, Shipping** (Dozer)	2251 kg	4963 lb	2333 kg	5143 lb	2570 kg	5666 lb	2418 kg	5331 lb
Tractor and Dozer Dimensions:								
A Length (Blade Straight)	4903 mm	193.1"	5095 mm	200.6"	5332 mm	210.0"	5465 mm	215.2"
Blade Dimensions:								
B Width (including std. end bits)	3360 mm	132.3"	3260 mm	128.3"	3260 mm	128.3"	4063 mm	160"
C Height	1257 mm	49.5"	1412 mm	55.6"	1412 mm	55.6"	1101 mm	43.3"
D Max. Digging Depth	473 mm	18.6"	473 mm	18.6"	459 mm	18.1"	655 mm	25.8"
E Ground Clearance @ Full Lift	1104 mm	43.5"	1104 mm	43.5"	1195 mm	47.0"	1083 mm	42.6"
G Max. Pitch Adjustment	+5.3 to 4.8°		+5.6 to -5.2°		+5.6 to -5.2°		+4.4 to -4.4°	
H Max. Hydraulic Tilt	765 mm	30.1"	743 mm	29.3"	743 mm	29.3"	701 mm	27.6"
K Push Arm Trunnion Width (to Ball Centers)	2640 mm	103.9"	2640 mm	103.9"	2640 mm	103.9"	3490 mm	137.4"

MODEL	D6R2				D6T			
	6A		6A XL		6A		6SU	
Gauge	1880 mm	74"	1880 mm	74"	1880 mm	74"	1880 mm	74"
Type	Angling		Angling		Angling		Semi-Universal	
Blade Capacities*	3.93 m ³	5.1 yd ³	3.89 m ³	5.1 yd ³	3.64 m ³	4.75 yd ³	5.35 m ³	6.99 yd ³
Weight, Shipping** (Dozer)	2715 kg	5986 lb	2625 kg	5787 lb	3138 kg	6904 lb	2973 kg	6540 lb
Tractor and Dozer Dimensions:								
A Length (Blade Straight)	5007 mm	197.2"	5209 mm	205.1"	5.00 m	16'5"	5.08 m	17'6"
Length (Blade Angled)	—	—	—	—	5.83 m	19'2"	—	—
Width (Blade Angled)	—	—	—	—	3.78 m	12'5"	—	—
Width (with C-Frame only)	—	—	—	—	2.93 m	9'8"	—	—
Blade Dimensions:								
B Width (including std. end bits)	4166 mm	164.0"	4166 mm	164.0"	4.16 m	13'8"	3.26 m	10'8"
C Height	1155 mm	45.5"	1155 mm	45.5"	1154 mm	3'10"	1411 mm	4'8"
D Max. Digging Depth	506 mm	19.9"	524 mm	20.6"	506 mm	1'8"	453 mm	1'6"
E Ground Clearance @ Full Lift	1142 mm	45.0"	1205 mm	47.4"	1144 mm	3'9"	1204 mm	3'11"
G Max. Pitch Adjustment	25°		25°		—		+5.6° to -5.2°	
H Max. Hydraulic Tilt	408 mm	16.1"	408 mm	16.1"	519 mm	1'8"	811 mm	2'8"
Blade Angle	—	—	—	—	25°		—	
J Hydraulic Tilt (Manual Brace Centered)	—	—	—	—	—		455 mm	1'6"
K Push Arm Trunnion Width (to Ball Centers)	2640 mm	103.9"	2625 mm	103.9"	2.58 m	8'6"	2.58 m	8'6"

*Blade capacities as determined by SAE J1265. Tractor and dozer dimensions variations due to SystemOne undercarriage products are negligible. Notice that the capacity of the SU-blade is the volume carried by a straight blade of the same dimensions plus the volume included in the "cup" of the SU-blade. It is intended for relative comparisons of dozer sizes, and not for predicting capacities or productivities in actual field conditions.

**Shipping Weight — Total Bulldozer Arrangement includes: Blade, push arms or C-frame, braces, cylinders, lines, trunnions and lift cylinder mountings.

MODEL	D6T							
	6A XL		6SU XL		6VPAT XL		6A XW	
Gauge	1.88 m	74"	1.88 m	74"	2.13 m	84"	2.03 m	80"
Type	Angling		Semi-Universal		VPAT		Angling	
Blade Capacities*	3.94 m ³	5.15 yd ³	5.55 m ³	7.26 yd ³	4.64 m ³	6.07 yd ³	4.35 m ³	5.69 yd ³
Weight, Shipping** (Dozer)	3086 kg	6803 lb	2831 kg	6242 lb	3464 kg	7637 lb	3731 kg	8226 lb
Tractor and Dozer Dimensions:								
A Length (Blade Straight)	5.21 m	17'1"	5.33 m	17'6"	5.39 m	17'8"	5.29 m	17'4"
Length (Blade Angled)	6.05 m	19'10"	—	—	3.54 m	11'7"	6.20 m	20'4"
Width (Blade Angled)	3.77 m	12'5"	—	—	3.49 m	11'5"	4.11 m	13'6"
Width (with C-Frame only)	2.99 m	9'10"	—	—	—	—	3.29 m	10'10"
Blade Dimensions:								
B Width (including std. end bits)	4.16 m	13'8"	3.26 m	10'8"	3.88 m	12'9"	4.52 m	14'10"
C Height	1154 mm	3'10"	1407 mm	4'7"	1294 mm	4'3"	1153 mm	3'9"
D Max. Digging Depth	555 mm	1'10"	501 mm	1'7"	792 mm	2'7"	541 mm	1'9"
E Ground Clearance @ Full Lift	1112 mm	3'7"	1180 mm	3'10"	1053 mm	3'5"	1139 mm	3'9"
G Max. Pitch Adjustment	—	—	+4.0° to -4.0°	—	+0.5° to -3.1°	—	—	—
H Max. Hydraulic Tilt	424 mm	1'5"	811 mm	2'8"	410 mm	1'4"	424 mm	1'5"
Blade Angle	25°	—	—	—	24°	—	25°	—
J Hydraulic Tilt (Manual Brace Centered)	—	—	455 mm	1'6"	—	—	—	—
K Push Arm Trunnion Width (to Ball Centers)	2.58 m	8'6"	2.58 m	8'6"	—	—	2.89 m	9'8"

MODEL	D6T							
	6SU XW		6A LGP		6S LGP		6VPAT LGP/XW	
Gauge	2.03 m	80"	2.29 m	90"	2.29 m	90"	2.29 m	90"
Type	Semi-Universal		Angling		Straight		VPAT	
Blade Capacities*	5.64 m ³	7.38 yd ³	4.94 m ³	6.46 yd ³	3.79 m ³	4.96 yd ³	5.02 m ³	6.57 yd ³
Weight, Shipping** (Dozer)	2976 kg	6562 lb	3745 kg	8255 lb	2720 kg	5997 lb	3558 kg	7845 lb
Tractor and Dozer Dimensions:								
A Length (Blade Straight)	5.33 m	17'6"	5.81 m	19'1"	5.50 m	18'1"	5.53 m	18'2"
Length (Blade Angled)	—	—	6.81 m	22'4"	—	—	—	—
Width (Blade Angled)	—	—	4.63 m	15'2"	—	—	3.72 m	12'2"
Width (with C-Frame only)	—	—	3.77 m	12'5"	—	—	—	—
Blade Dimensions:								
B Width (including std. end bits)	3.56 m	11'8"	5.07 m	16'8"	4.06 m	13'3"	4.16 m	13'8"
C Height	1407 mm	4'7"	1150 mm	3'9"	1108 mm	3'8"	1294 mm	4'3"
D Max. Digging Depth	502 mm	1'7"	853 mm	2'10"	590 mm	1'11"	743 mm	2'5"
E Ground Clearance @ Full Lift	1180 mm	3'10"	1004 mm	3'3"	1094 mm	3'7"	1102 mm	3'7"
G Max. Pitch Adjustment	+4.0° to -4.0°	—	—	—	+4.4° to -4.4°	—	+0.5° to -3.1°	—
H Max. Hydraulic Tilt	791 mm	2'7"	618 mm	2'0"	747 mm	2'5"	435 mm	1'5"
Blade Angle	—	—	24.2°	—	—	—	24°	—
J Hydraulic Tilt (Manual Brace Centered)	442 mm	1'5"	—	—	399 mm	1'4"	—	—
K Push Arm Trunnion Width (to Ball Centers)	2.89 m	9'8"	3.42 m	11'5"	3.42 m	11'5"	—	—

*Blade capacities as determined by SAE J1265.

Notice that the capacity of the SU-blade is the volume carried by a straight blade of the same dimensions plus the volume included in the "cup" of the SU-blade. It is intended for **relative comparisons of dozer sizes**, and not for predicting capacities or productivities in actual field conditions.

**Shipping Weight — Total Bulldozer Arrangement includes: Blade, push arms or C-frame, braces, cylinders, lines, trunnions and lift cylinder mountings.

MODEL	D7E							
	7A		7S		7SU		7U	
Type	Angling		Straight		Semi-Universal		Universal	
Blade Capacities*	5.9 m ³	7.7 yd ³	6.0 m ³	7.8 yd ³	6.6 m ³	8.7 yd ³	8.1 m ³	10.6 yd ³
Weight, Shipping** (Dozer)	3945 kg	8697 lb	3718 kg	8196 lb	3778 kg	8329 lb	4020 kg	8862 lb
Tractor and Dozer Dimensions:								
A Length (Blade Straight)	6.20 m	20'4"	5.92 m	19'5"	6.17 m	20'3"	6.38 m	20'11"
Length (Blade Angled)	7.07 m	23'2"	—	—	—	—	—	—
Width (Blade Angled)	4.12 m	13'6"	—	—	—	—	—	—
Width (with C-Frame only)	3.40 m	11'2"	—	—	—	—	—	—
Blade Dimensions:								
B Width (including std. end bits)	4.50 m	14'9"	3.90 m	12'10"	3.71 m	12'2"	4.02 m	13'2"
C Height	1423 mm	4'8"	1522 mm	5'0"	1524 mm	5'0"	1550 mm	5'1"
D Max. Digging Depth	715 mm	2'4"	555 mm	1'10"	555 mm	1'10"	555 mm	1'10"
E Ground Clearance @ Full Lift	1159 mm	3'10"	1159 mm	3'10"	1159 mm	3'10"	1159 mm	3'10"
G Max. Pitch Adjustment	—	—	52° to 58°		52° to 58°		52° to 58°	
Blade Angle (either side)	25°		—		—		—	
H Max. Hydraulic Tilt	631 mm	2'1"	590 mm	1'11"	551 mm	1'10"	601 mm	2'0"
J Hydraulic Tilt (Manual Brace Centered)	—		530 mm	1'9"	500 mm	1'8"	550 mm	1'10"
K Push Arm Trunnion Width (to Ball Centers)	2.81 m	9'2"	2.81 m	9'2"	2.81 m	9'2"	2.81 m	9'2"

MODEL	D7E		D7R/D7R XR				D7R LGP	
	7S LGP		7SU		7A		7S	
Type	Straight		Semi-Universal		Angling		Straight	
Blade Capacities*	6.1 m ³	7.9 yd ³	6.86 m ³	8.98 yd ³	3.89 m ³	5.07 yd ³	5.89 m ³	7.7 yd ³
Weight, Shipping** (Dozer)	3855 kg	8498 lb	3593 kg	7904 lb	3523 kg	7751 lb	3732 kg	8229 lb
Tractor and Dozer Dimensions:								
A Length (Blade Straight)	6.28 m	20'7"	6.03 m	19'9"	4218 mm	13'10"	5.81 m	19'1"
Length (Blade Angled)	—	—	—	—	5098 mm	16'9"	—	—
Width (Blade Angled)	—	—	—	—	4114 mm	13'6"	—	—
Width (with C-Frame only)	—	—	—	—	3073 mm	10'1"	—	—
Blade Dimensions:								
B Width (including std. end bits)	4.59 m	15'1"	3.69 m	12'1"	4503 mm	14'9"	4.50 m	14'9"
C Height	1351 mm	4'5"	1524 mm	5'0"	1111 mm	3'8"	1343 mm	4'4.9"
D Max. Digging Depth	631 mm	2'1"	527 mm	1'8.7"	647 mm	2'1"	668 mm	2'2.3"
E Ground Clearance @ Full Lift	1292 mm	4'3"	1145 mm	3'9.1"	1340 mm	4'5"	1153 mm	3'9.4"
G Max. Pitch Adjustment	54° to 60°		+3.1° to 3.9°		—		+3.0° to 3.9°	
Blade Angle (either side)	778 mm	2'7"	—		25°		—	
H Max. Hydraulic Tilt	468 mm	1'7"	799 mm	2'7.4"	466 mm	1'6"	686 mm	2'3"
J Hydraulic Tilt (Manual Brace Centered)	3.35 m	11'0"	474 mm	18.6"	627 mm	2'1"	426 mm	16.8"
K Push Arm Trunnion Width (to Ball Centers)	—	—	2.87 m	9'5"	2795 mm	9'2"	3.37 m	11'1"

*Blade capacities as determined by SAE J1265.

Notice that the capacity of the U-blade is the volume carried by a straight blade of the same dimensions plus the volume included in the "cup" of the U-blade. It is intended for **relative comparisons of dozer sizes**, and not for predicting capacities or productivities in actual field conditions.

Notice that the capacity of the SU-blade is the volume carried by a straight blade of the same dimensions plus the volume included in the "cup" of the SU-blade. It is intended for **relative comparisons of dozer sizes**, and not for predicting capacities or productivities in actual field conditions.

**Shipping Weight — Total Bulldozer Arrangement includes: Blade, push arms or C-frame, braces, cylinders, lines, trunnions and lift cylinder mountings.

MODEL	D8R/D8T							
	8A		8SU		8U		8SU LGP	
Type	Angling		Semi-U		Universal		Semi-U	
Blade Capacities*	5.2 m ³	6.8 yd³	8.6 m ³	11.3 yd³	11.8 m ³	15.4 yd³	9.9 m ³	12.9 yd³
Weight, Shipping** (Dozer)	5121 kg	11,289 lb	4260 kg	9392 lb	4895 kg	10,793 lb	4703 kg	10,368 lb
Tractor and Dozer Dimensions:								
A Length (Blade Straight)	6.57 m	21'7"	6.39 m	21'0"	6.79 m	22'3"	6281 mm	20'7"
Length (Blade Angled)	7.62 m	25'0"	—	—	—	—	—	—
Width (Blade Angled)	4.52 m	14'10"	—	—	—	—	—	—
Width (with C-Frame only)	3.38 m	11'1"	—	—	—	—	—	—
Blade Dimensions:								
B Width (including std. end bits)	5.00 m	16'5"	3.93 m	12'11"	4.25 m	13'11"	4.53 m	14'10"
C Height	1174 mm	3'10"	1690 mm	5'7"	1740 mm	5'9"	1622 mm	5'4"
D Max. Digging Depth	625 mm	2'1"	511 mm	20.1"	567 mm	1'10"	513 mm	1'9"
E Ground Clearance @ Full Lift	1323 mm	4'3"	1310 mm	4'4"	1239 mm	4'1"	1308 mm	4'3.5"
G Max. Pitch Adjustment	—	—	+3.0° to 2.9°		+3.0° to 2.9°		—	—
Blade Angle (either side)	25°	—	—	—	—	—	—	—
H Max. Hydraulic Tilt	733 mm	2'5"	861 mm	2'10"	996 mm	3'3"	908 mm	3'0"
J Hydraulic Tilt (Manual Brace Centered)	—	—	585 mm	1'11"	635 mm	2'1"	—	—
K Push Arm Trunnion Width (to Ball Centers)	2983 mm	9'9"	2983 mm	9'9"	2983 mm	9'9"	3329 mm	10'11"
Maximum Track Width Permitted	710 mm	2'4"	710 mm	2'4"	710 mm	2'4"	965 mm	3'2"
Dual Tilt Option								
G Dual Pitch Adj.	—	—	±4.6°		±4.6°		—	—
H Dual Max. Hyd. Tilt	—	—	879 mm	2'11"	950 mm	3'1"	—	—

*Blade capacities as determined by SAE J1265.

Notice that the capacity of the U-blade is the volume carried by a straight blade of the same dimensions plus the volume included in the "cup" of the U-blade. It is intended for **relative comparisons of dozer sizes**, and not for predicting capacities or productivities in actual field conditions.

Notice that the capacity of the SU-blade is the volume carried by a straight blade of the same dimensions plus the volume included in the "cup" of the SU-blade. It is intended for **relative comparisons of dozer sizes**, and not for predicting capacities or productivities in actual field conditions.

**Shipping Weight — Total Bulldozer Arrangement includes: Blade, push arms or C-frame, braces, cylinders, lines, trunnions and lift cylinder mountings.

MODEL	D9R/D9T			
	9SU		9U	
Type	Semi-U		Universal	
Blade Capacities*	13.5 m ³	17.7 yd ³	16.4 m ³	21.4 yd ³
Weight, Shipping** (Dozer)	6863 kg	15,130 lb	7388 kg	16,288 lb
Tractor and Dozer Dimensions:				
A Length (Blade Straight)	6.60 m	21'6"	6.96 m	22'8"
Blade Dimensions:				
B Width (including std. end bits)	4.31 m	14'1"	4.65 m	15'2"
C Height	1934 mm	6'4.1"	1934 mm	6'4.1"
D Max. Digging Depth	606 mm	1'11.9"	606 mm	1'11.9"
E Ground Clearance @ Full Lift	1422 mm	4'8"	1422 mm	4'8"
G Max. Pitch Adjustment	+3.4° to 2.9°		+3.4° to 2.9°	
H Max. Hydraulic Tilt	940 mm	3'1"	1014 mm	3'3.9"
J Hydraulic Tilt (Manual Brace Centered)	570 mm	1'10.4"	616 mm	2'0.3"
K Push Arm Trunnion Width (to Ball Centers)	3.30 m	10'8"	3.30 m	10'8"
Maximum Track Width Permitted	762 mm	2'6"	762 mm	2'6"
Dual Tilt Option				
G Dual Pitch Adj.	+4.8° to 5.2°		+4.8° to 4.9°	
H Dual Max. Hyd. Tilt	1139 mm	3'8.8"	1231 mm	4'0.5"

*Blade capacities as determined by SAE J1265.

Notice that the capacity of the U-blade is the volume carried by a straight blade of the same dimensions plus the volume included in the "cup" of the U-blade. It is intended for **relative comparisons of dozer sizes**, and not for predicting capacities or productivities in actual field conditions.

Notice that the capacity of the SU-blade is the volume carried by a straight blade of the same dimensions plus the volume included in the "cup" of the SU-blade. It is intended for **relative comparisons of dozer sizes**, and not for predicting capacities or productivities in actual field conditions.

**Shipping Weight — Total Bulldozer Arrangement includes: Blade, push arms or C-frame, braces, cylinders, lines, trunnions and lift cylinder mountings.

MODEL	D10T2			
	10SU		10U	
Type	Semi-U		Universal	
Blade Capacities*	18.5 m ³	24.2 yd ³	22.0 m ³	28.7 yd ³
Weight, Shipping**				
Standard Dozer	10 229 kg	22,550 lb	10 784 kg	23,775 lb
Abrasion Dozer	11 069 kg	24,403 lb	12 413 kg	27,366 lb
Tractor and Dozer Dimensions:				
A Length	7.37 m	24'2"	7.73 m	25'4"
Width	4.86 m	15'11"	5.26 m	17'3"
Blade Dimensions:				
B Width (including std. end bits)	4.94 m	16'3"	5.26 m	17'3"
C Height	2.12 m	6'11"	2.12 m	6'11"
D Max. Digging Depth	674 mm	2'2.5"	674 mm	2'2.5"
E Ground Clearance @ Full Lift	1497 mm	4'10.9"	1497 mm	4'10.9"
G Max. Pitch Adjustment	+1.7° to 2.3°		+1.7° to 2.3°	
H Max. Hydraulic Tilt	993 mm	3'3.1"	1074 mm	3'6.3"
J Hydraulic Tilt (Manual Brace Centered)	722 mm	2'4.4"	782 mm	2'6.8"
K Push Arm Trunnion Width (to Ball Centers)	3.60 m	11'10"	3.60 m	11'10"
Maximum Track Width Permitted	762 mm	2'6"	762 mm	2'6"
Dual Tilt Option				
G Dual Pitch Adjustment	+5.2° to 5.5°		+5.2° to 5.5°	
H Dual Max. Hyd. Tilt	1441 mm	4'8.7"	1560 mm	5'1.4"

*Blade capacities as determined by SAE J1265.
 Notice that the capacity of the U-blade is the volume carried by a straight blade of the same dimensions plus the volume included in the "cup" of the U-blade. It is intended for **relative comparisons of dozer sizes**, and not for predicting capacities or productivities in actual field conditions.
 Notice that the capacity of the SU-blade is the volume carried by a straight blade of the same dimensions plus the volume included in the "cup" of the SU-blade. It is intended for **relative comparisons of dozer sizes**, and not for predicting capacities or productivities in actual field conditions.
 **Shipping Weight — Total Bulldozer Arrangement includes: Blade, push arms or C-frame, braces, cylinders, lines, trunnions and lift cylinder mountings.

All dimensions are approximate.

MODEL	D11T					
	11SU		11U		11 CD	
Type	Semi-U		Universal		CarryDozer	
Blade Capacities*	27.2 m ³	35.5 yd ³	34.4 m ³	45.0 yd ³	43.6 m ³	57.0 yd ³
Weight, Shipping**						
Standard Dozer	14 813 kg	32,658 lb	17 296 kg	38,131 lb	24 085 kg	53,099 lb
Abrasion Dozer	16 192 kg	35,698 lb	18 823 kg	41,498 lb	—	—
Tractor and Dozer Dimensions:						
A Length	8.58 m	28'2"	8.64 m	28'4"	8.77 m	28'9"
Width	5.50 m	18'1"	6.26 m	20'7"	6.43 m	21'1"
Blade Dimensions:						
B Width (including std. end bits)	5.58 m	18'4"	6.35 m	20'10"	6.71 m	22'0"
C Height	2.75 m	9'0"	2.83 m	9'3"	2.96 m***	9'8"***
D Max. Digging Depth	766 mm	2'6.2"	766 mm	2'6.2"	688 mm	2'3"
E Ground Clearance @ Full Lift	1533 mm	5'0.4"	1533 mm	5'0.4"	1850 mm	6'1"
G Max. Pitch Adjustment	+2.1° to 2.2°		+2.1° to 2.2°		—	
H Max. Hydraulic Tilt	1184 mm	3'10.6"	1344 mm	4'4.9"	1800 mm	5'11"
J Hydraulic Tilt (Manual Brace Centered)	886 mm	2'10.9"	1006 mm	3'3.6"	—	
K Push Arm Trunnion Width (to Ball Centers)	4.18 m	13'9"	4.18 m	13'9"	4.18 m	13'9"
Maximum Track Width Permitted	914 mm	3'0"	914 mm	3'0"	914 mm	3'0"
Dual Tilt Option	+7.5° to 7.6° or		+7.5° to 7.6° or		+47.8° to 10.4°	
G Dual Pitch Adjustment	+0° to 13°		+0° to 13°		—	
H Dual Max. Hyd. Tilt	1706 mm	5'7.2"	1938 mm	6'4.3"	—	

*Blade capacities as determined by SAE J1265.

Notice that the capacity of the U-blade is the volume carried by a straight blade of the same dimensions plus the volume included in the "cup" of the U-blade. It is intended for **relative comparisons of dozer sizes**, and not for predicting capacities or productivities in actual field conditions.

Notice that the capacity of the SU-blade is the volume carried by a straight blade of the same dimensions plus the volume included in the "cup" of the SU-blade. It is intended for **relative comparisons of dozer sizes**, and not for predicting capacities or productivities in actual field conditions.

**Shipping Weight — Total Bulldozer Arrangement includes: Blade, push arms or C-frame, braces, cylinders, lines, trunnions and lift cylinder mountings.

***Blade height with cutting edge at 53°.

All dimensions are approximate.

BULLDOZER PRODUCTION OFF-THE-JOB

You can estimate bulldozer production using the production curves that follow and the correction factors that are applicable. Use this formula:

$$\text{Production (Lm}^3\text{/hr)} = \frac{\text{Maximum production}}{\text{LCY/hr}} \times \frac{\text{Correction factors}}{\text{LCY/hr}}$$

The bulldozer production curves give maximum uncorrected production for universal, semi-universal, and straight blades and are based on the following conditions:

1. 100% efficiency (60 minute hour — level cycle).
2. Power shift machines with 0.05 min. fixed times.
3. Machine cuts for 15 m (50 feet), then drifts blade load to dump over a high wall. (Dump time — 0 sec.)
4. Soil density of 1370 kg/Lm³ (2300 lb/LCY).
5. Coefficient of traction:*
 - a. Track machines — 0.5 or better
 - b. Wheel machines — 0.4 or better
6. Hydraulic controlled blades used.
7. Dig 1F**
Carry 2F**
Return 2R**

To obtain estimated production in bank cubic meters or bank cubic yards, appropriate load factor from the Tables section should be applied to the corrected production as calculated above.

$$\text{Production Bm}^3\text{/hr} = \frac{\text{Lm}^3\text{/hr}}{\text{(BCY/h)}} \times \frac{\text{LF}}{\text{LCY/h}} \times \text{LF}$$

*Coefficient of traction assumed to be at least 0.4. While poor traction affects both track and wheel vehicles, causing them to take smaller blade loads, wheeled units are affected more severely and production falls much more rapidly. While no fixed rules can predict this production loss, a rough rule of thumb is that wheel dozer production falls off 4% for each one-hundredth decrease in coefficient of traction below 0.40. If, for example, coefficient of traction is 0.30, the difference is ten-hundredths (0.10), and production is 60% (10 × 4% = 40% decrease).

**This gear sequence is based on level to downhill terrain, light to medium density material, and no blade extensions such as spill plates, rock guards, etc. Exceeding these conditions may require carry in 1F, but productivity should equal or exceed “standard conditions” due to the larger loads that can be carried in 1F.

ESTIMATED DOZING PRODUCTION • Universal Blades • D7E through D11T CD

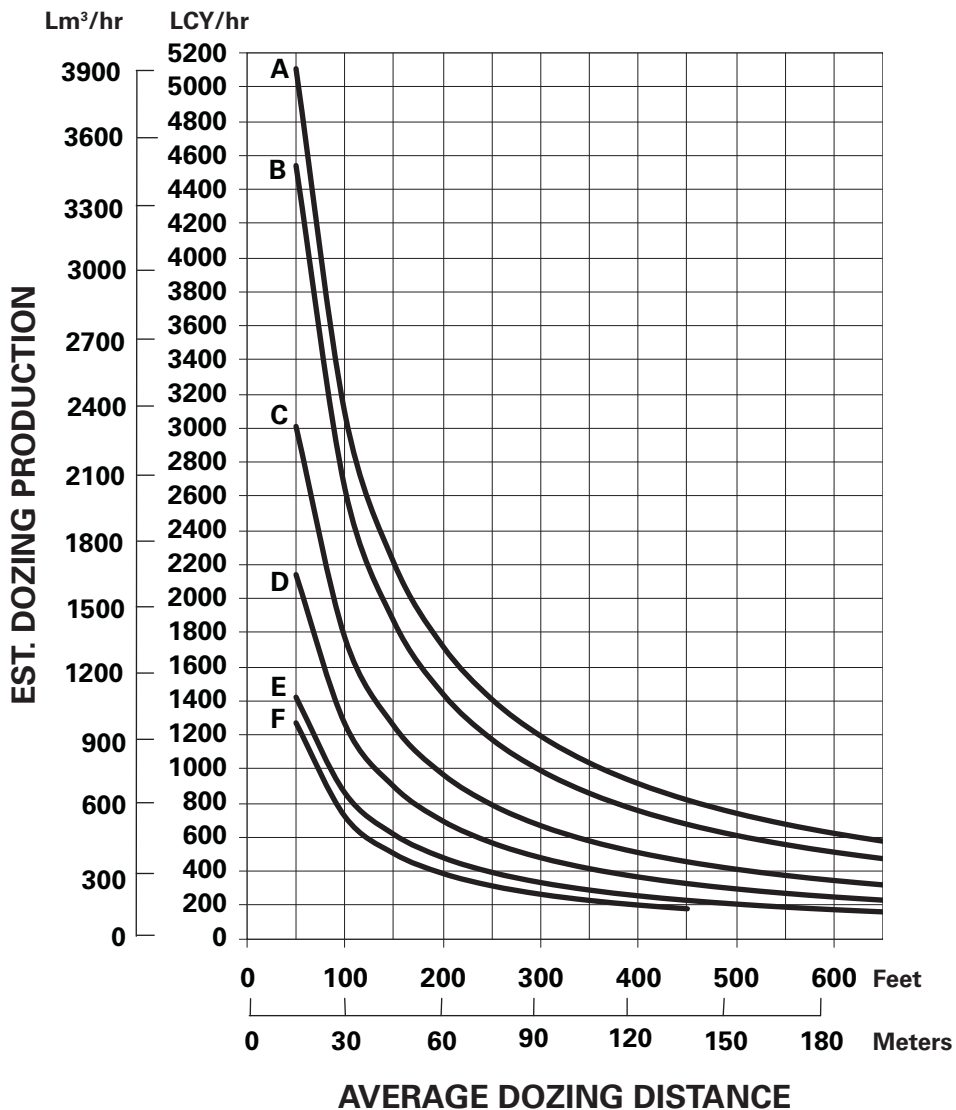

KEY

- A — D11T CD
- B — D11T
- C — D10T2
- D — D9T
- E — D8T
- F — D7E

NOTE: This chart is based on numerous field studies made under varying job conditions. Refer to correction factors following these charts.

ESTIMATED DOZING PRODUCTION ● Semi-Universal Blades ● D7E through D11T

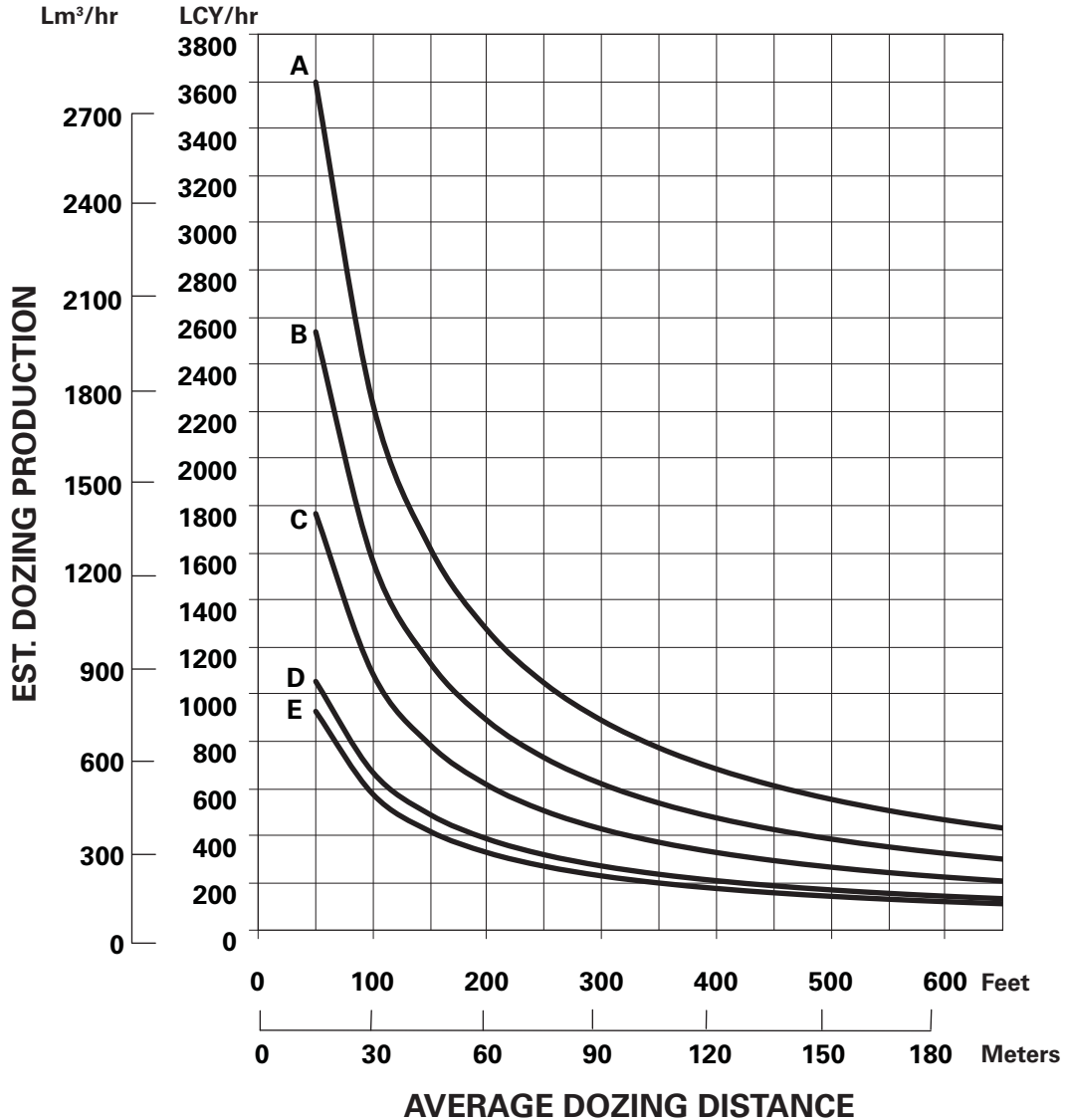

KEY

- A — D11T
- B — D10T2
- C — D9T
- D — D8T
- E — D7E

NOTE: This chart is based on numerous field studies made under varying job conditions. Refer to correction factors following these charts.

ESTIMATED DOZING PRODUCTION • Semi-Universal Blades • D6N through D8R

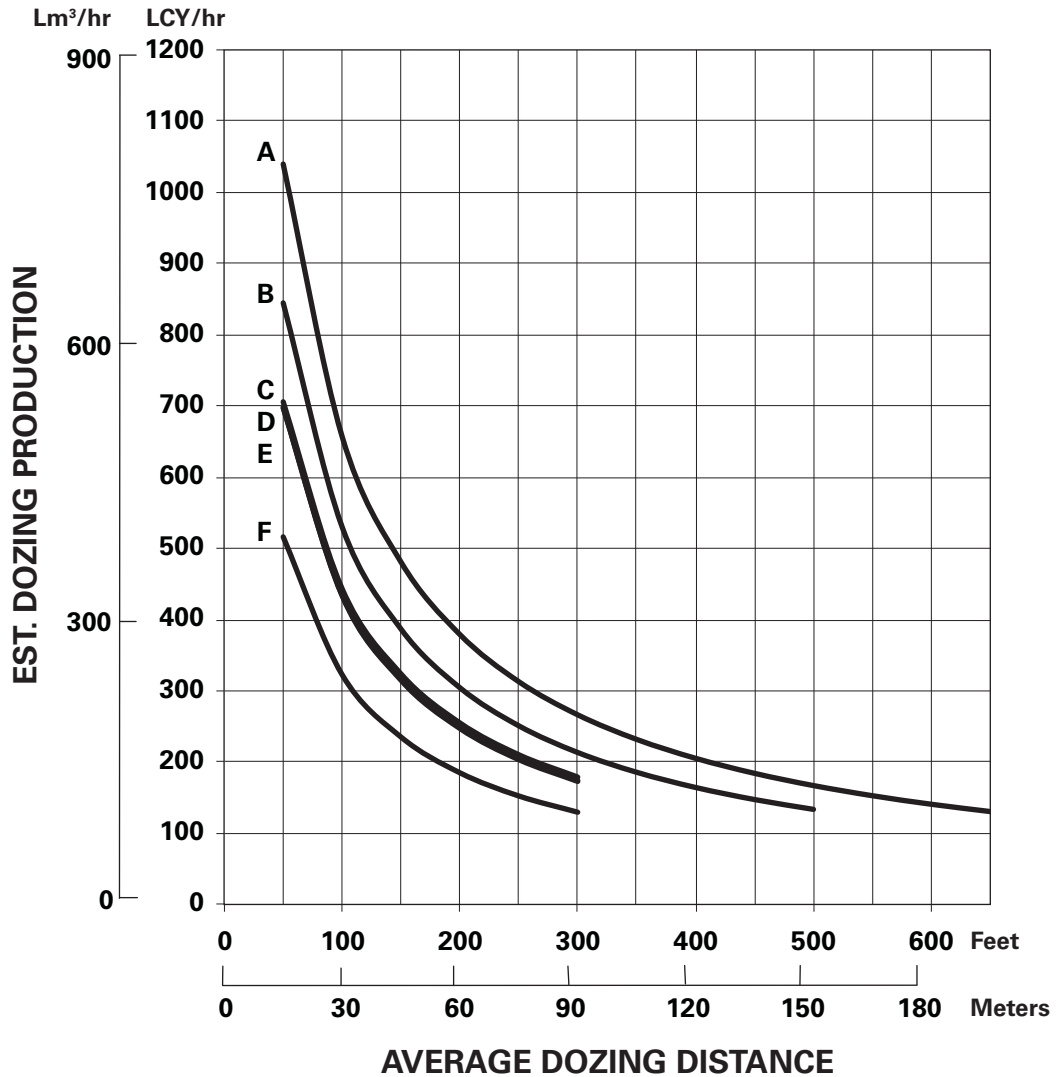

KEY

- A — D8R
- B — D7R
- C — D6T Tier 4 Interim/Stage IIIB/Japan 2011 (Tier 4 Interim)
- D — D6T
- E — D6R
- F — D6N

NOTE: This chart is based on numerous field studies made under varying job conditions. Refer to correction factors following these charts.

ESTIMATED DOZING PRODUCTION ● Straight Blades ● D6T through D7E

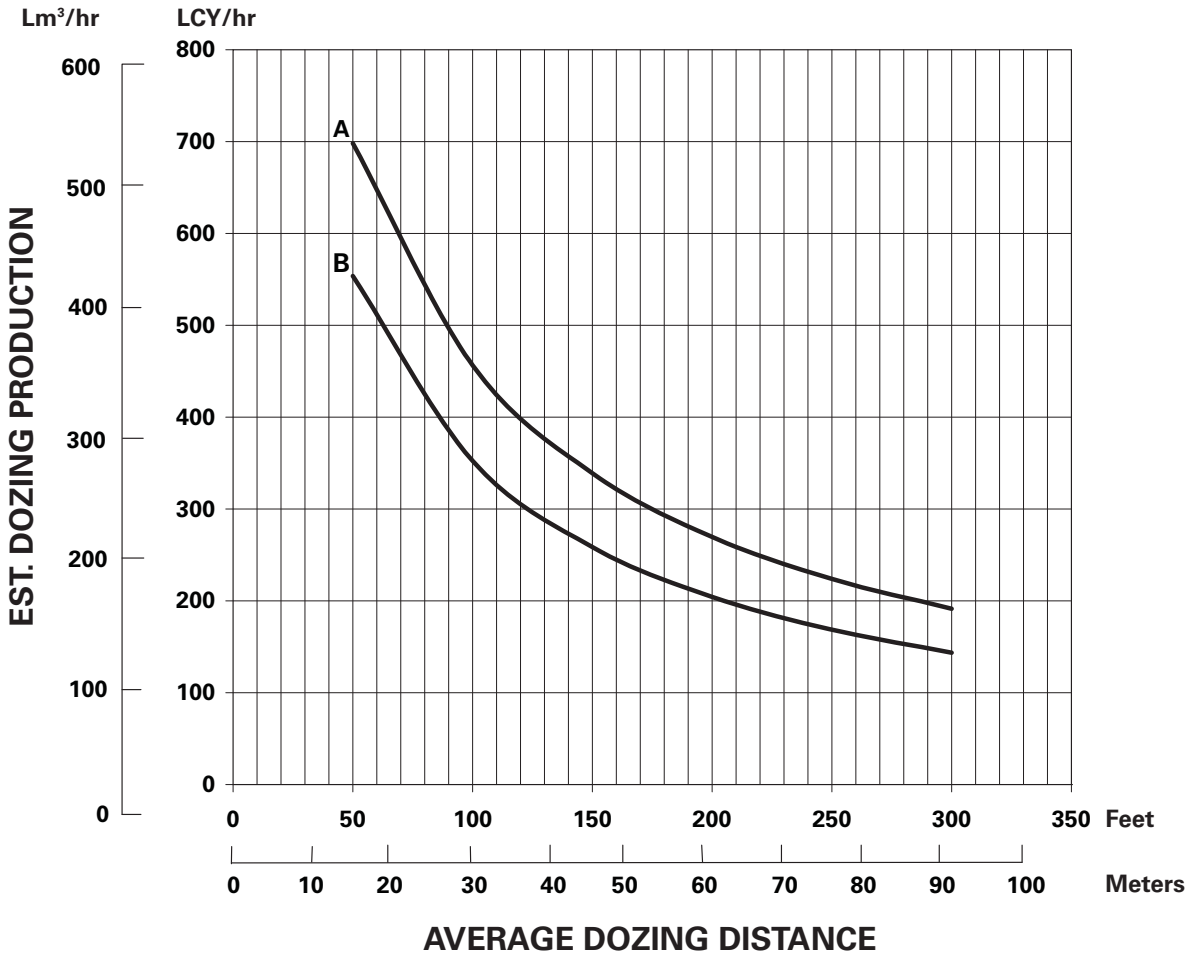

KEY

A — D7E

B — D6T

NOTE: This chart is based on numerous field studies made under varying job conditions. Refer to correction factors following these charts.

JOB CONDITION CORRECTION FACTORS

	TRACK-TYPE TRACTOR
OPERATOR —	
Excellent	1.00
Average	0.75
Poor	0.60
MATERIAL —	
Loose stockpile	1.20
Hard to cut; frozen —	
with tilt cylinder	0.80
without tilt cylinder	0.70
Hard to drift; "dead" (dry, non-cohesive material) or very sticky material	0.80
Rock, ripped or blasted	0.60-0.80
SLOT DOZING	1.20
SIDE BY SIDE DOZING	1.15-1.25
VISIBILITY —	
Dust, rain, snow, fog or darkness	0.80
JOB EFFICIENCY —	
50 min/hr	0.83
40 min/hr	0.67
BULLDOZER*	
Adjust based on SAE capacity relative to the base blade used in the Estimated Dozing Production graphs.	
GRADES — See following graph.	

*NOTE: Angling blades and cushion blades are not considered production dozing tools. Depending on job conditions, the A-blade and C-blade will average 50-75% of straight blade production.

% Grade vs. Dozing Factor

(-) Downhill
 (+) Uphill

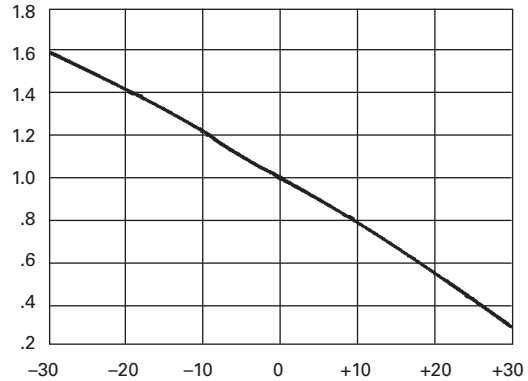

ESTIMATING DOZER PRODUCTION OFF-THE-JOB

Example problem:

Determine average hourly production of a D8T/8SU (with tilt cylinder) moving hard-packed clay an average distance of 45 m (150 feet) down a 15% grade, using a slot dozing technique.

Estimated material weight is 1600 kg/Lm³ (2650 lb/LCY). Operator is average. Job efficiency is estimated at 50 min/hr.

Uncorrected Maximum Production — 458 Lm³/h (600 LCY/hr) (example only)

Applicable Correction Factors:

- Hard-packed clay is "hard to cut" material . . . -0.80
- Grade correction (from graph) -1.30
- Slot dozing -1.20
- Average operator -0.75
- Job efficiency (50 min/hr) -0.83
- Weight correction. (2300/2650) -0.87

$$\begin{aligned}
 \text{Production} &= \text{Maximum Production} \times \text{Correction Factors} \\
 &= (600 \text{ LCY/hr}) (0.80) (1.30) (1.20) (0.75) \\
 &\quad (0.83) (0.87) \\
 &= 405.5 \text{ LCY/hr}
 \end{aligned}$$

To obtain production in metric units, the same procedure is used substituting maximum uncorrected production in Lm³.

$$\begin{aligned}
 &= 458 \text{ Lm}^3/\text{h} \times \text{Factors} \\
 &= 309.6 \text{ Lm}^3/\text{h}
 \end{aligned}$$

MEASURING PRODUCTION ON-THE-JOB

Three generally accepted methods of measuring bulldozer production are listed below. The third method is empirical, but is the simplest to conduct.

1. Employing Surveying Techniques
 - a. Conduct time study and then cross-section the cut to determine the volume of material removed. (Production in Bm^3 or BCY per unit of time)
 - b. Conduct time study and then cross-section the fill to determine the volume of fill material. (Production in Lm^3 or LCY per unit of time)
2. Weighing Blade Loads
Conduct time study and weigh material moved by bulldozer by weighing the loader bucket loads.
3. Measuring Blade Loads
 - a. Dozer operation
 - (1) Pick up and carry load onto a level area and stop.
 - (2) Raise the blade directly over the pile pulling forward slightly as blade comes up, leaving a nearly symmetrical pile.
 - (3) Reverse to clear the pile.
 - b. Measurements
 - (1) The average *height* (H) of the pile in feet. Hold the tape vertically at the inside edge of each grouser mark. Sight along top of the pile to obtain the correct measurement.

TOP VIEW

SIDE VIEW

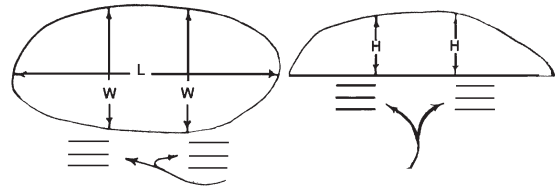

GROUSER MARKS

- (2) The average *width* (W) of the pile in feet. Hold the tape horizontally over the pile and sight at the inside edge of each grouser mark and the corresponding opposite side of the pile.
- (3) The greatest *length* (L) of the pile in feet. Hold the tape horizontally over the pile and sight at each end of the pile.
- c. With the above measurements, now compute the blade load.
 - (1) Average the height measurement (H)
 - (2) Average the width measurement (W)
 - (3) Load (Lm^3 or LCY) = $0.0138 \times (HWL)$
 - (4) Load (Bm^3 or BCY) = Lm^3 or LCY \times LF
- d. Combine the calculated blade load with time study to figure production.

ATTACHMENTS

**VARIABLE RADIUS (VR)
SEMI-U BLADES**

	D6T		D7R		D8R/D8T	
Capacity	5.81 m ³	7.6 yd³	7.84 m ³	10.25 yd³	11.28 m ³	14.75 yd³
Width	3349 mm	11'0"	3912 mm	12'10"	4369 mm	14'4"
Height	1473 mm	4'10"	1626 mm	5'4"	1778 mm	5'10"
Weight	1360 kg	3000 lb	2000 kg	4400 lb	3010 kg	6640 lb

LANDFILL BLADES

	D6T		D7E		D7R	
Capacity	12.5 m ³	16.4 yd³	14 m ³	18.4 yd³	18.1 m ³	23.7 yd³
Width	3886 mm	12'9"	3713 mm	12'2"	4267 mm	14'0"
Height	1796 mm	5'10.7"	1524 mm	5'0"	2083 mm	6'10"
Weight	1450 kg	3200 lb	4380 kg	9636 lb	2608 kg	5750 lb

LANDFILL BLADES

	D8R/D8T		D9R/D9T	
Capacity	24.4 m ³	32 yd³	38.5 m ³	50.3 yd³
Width	4928 mm	16'2"	5442 mm	17'10"
Height	2286 mm	7'6"	2178 mm	7'1.75"
Weight	3175 kg	7000 lb	4900 kg	10,800 lb

This list is not all inclusive. Contact your Cat dealer for special attachment needs.

- Special Attachments
- Coal U-Blades
 - Woodchip Dozers
 - Reclamation U-Blades
 - Cushion Dozers

COAL U-BLADES	D6T		D7E		D7E LGP	
Capacity	9.7 m ³	12.63 yd³	14.8 m ²	19.4 yd²	14.8 m ²	19.4 yd²
Width	4267 mm	14'0"	4902 mm	193"	4902 mm	193"
Height	1473 mm	4'10"	1778 mm	70"	1778 mm	70"
Weight	1452 kg	3200 lb	2420 kg	5335 lb	2592 kg	5714 lb

COAL U-BLADES	D8R/D8T		D9R/D9T		D10T2		D11T	
Capacity	21.4 m ³	28 yd³	37 m ³	48 yd³	46.1 m ³	60.3 yd³	74.9 m ³	98.0 yd³
Width	5537 mm	18'2"	5940 mm	18'10"	6191 mm	20'1"	7416 mm	24'4"
Height	1930 mm	6'4"	2540 mm	8'4"	2794 mm	9'2"	3330 mm	10'11"
Weight	3200 kg	7050 lb	4490 kg	9900 lb	6670 kg	14,700 lb	11 340 kg	25,000 lb

WOODCHIP DOZERS	D6T		D7E		D7E LGP	
Capacity	15 m ³	20 yd³	23.5 m ²	30.8 yd²	23.5 m ²	30.8 yd²
Width	4267 mm	14'0"	4902 mm	193"	4902 mm	193"
Height	1880 mm	6'2"	2286 mm	90"	2286 mm	90"
Weight	1724 kg	3800 lb	2731 kg	6020 lb	2896 kg	6384 lb

WOODCHIP DOZERS	D8R/D8T		D9R/D9T		D10T2	
Capacity	28.3 m ³	37 yd³	45.9 m ³	60 yd³	72.6 m ³	95 yd³
Width	5486 mm	18'0"	5486 mm	18'0"	6300 mm	20'8"
Height	2337 mm	7'8"	3086 mm	10'1.5"	3480 mm	11'5"
Weight	2903 kg	6400 lb	5080 kg	11,200 lb	7575 kg	16,700 lb

RECLAMATION U-BLADES	D8R/D8T		D9R/D9T		D10T2	
Capacity	16.4 m ³	21.5 yd³	20.9 m ³	27.3 yd³	30.6 m ³	40 yd³
Width	4877 mm	16'0"	5182 mm	17'0"	5664 mm	18'7"
Height	1880 mm	6'2"	2032 mm	6'8"	2388 mm	7'10"
Weight	3810 kg	8400 lb	5220 kg	11,500 lb	6440 kg	14,200 lb

CUSHION DOZERS	D8R/D8T		D9R/D9T		D10T2		D11T	
Width	2889 mm	9'5.75"	3048 mm	10'0"	3505 mm	11'6"		
Height	1499 mm	4'11"	1575 mm	5'2"	1676 mm	5'6"		*
Weight	3185 kg	7020 lb	4310 kg	9500 lb	6440 kg	14,200 lb		
Rear Cushion								
Push Block		*	2175 kg	4800 lb	3105 kg	6850 lb		*

*Available upon request.
This list is not all inclusive.

RIPPERS

CONTENTS

Features	19-59
Ripper Specification Diagrams	
Adjustable Parallelogram Ripper	19-60
Radial Ripper	19-62
Fixed Parallelogram Ripper	19-62
Specifications	
Track-Type Tractors	19-63
Tip Selection	19-73
Estimating Ripping Production	19-73
Seismic Wave Velocity Charts	19-76
Estimated Ripper Production Graphs	19-81

Features:

- **Parallelogram linkage with hydraulically variable pitch** on D7E, D7R, D8R/D8T, D9R/D9T, D10T2 and D11T. Operator can adjust angle of ripper tip to the material for penetration at all ripping depths to increase production.
- **Fixed Parallelogram linkage design** used on D3K2, D4K2, D5K2, D6K2, D6N, D6R, D6R XL, D6T and D6T XL. This design holds tooth angle constant at all ripping depths.
- **Adjustable Single shank** arrangements available for D8R/D8T, D9R/D9T, D10T2 and D11T for tough ripping applications and deep ripping requirements.
- **Hydraulically Variable Pitch Multi-shank** arrangements available on D7E, D7R, D8R/D8T, D9R/D9T, D10T2 and D11T allow wide-beam coverage in easier-to-rip materials.
- **Counterweighted CarryDozer Ripper single shank** available for D11T and D11T CD, multi-shank available for D11T CD.

DEFINITION OF FORCES SHOWN IN TABLES THAT FOLLOW

“Pryout,” (Breakout) kilonewtons (and pounds) — the maximum sustained upward force, generated by the lift cylinders measured at the ripper tip. Breakout force is measured with the shank in the top hole, shank vertical and ripper full down. Breakout force may be hydraulically or balance limited.

“Penetration force,” kilonewtons (and pounds) — the maximum sustained downward force, generated by the ripper lift cylinders measured at the ripper tip, which is required to raise the back end of the vehicle with the tip on ground and the shank (pinned in the top hole) vertical.

Adjustable Parallelogram Ripper

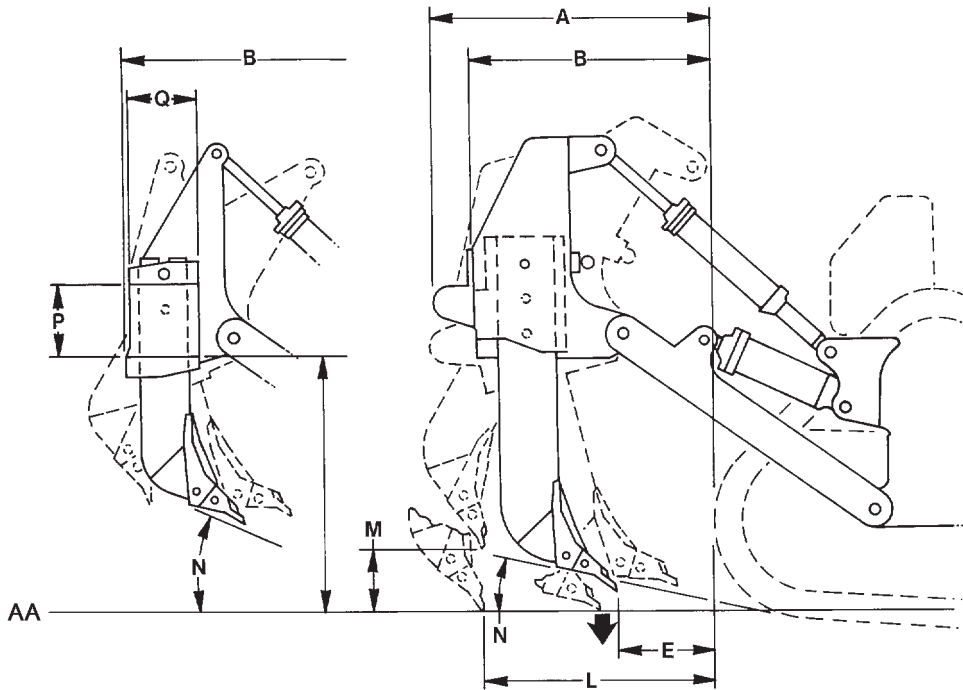

NOTE: Letters correspond to ripper specifications on pages that follow.

KEY

AA — Ground Line

Adjustable Parallelogram Ripper

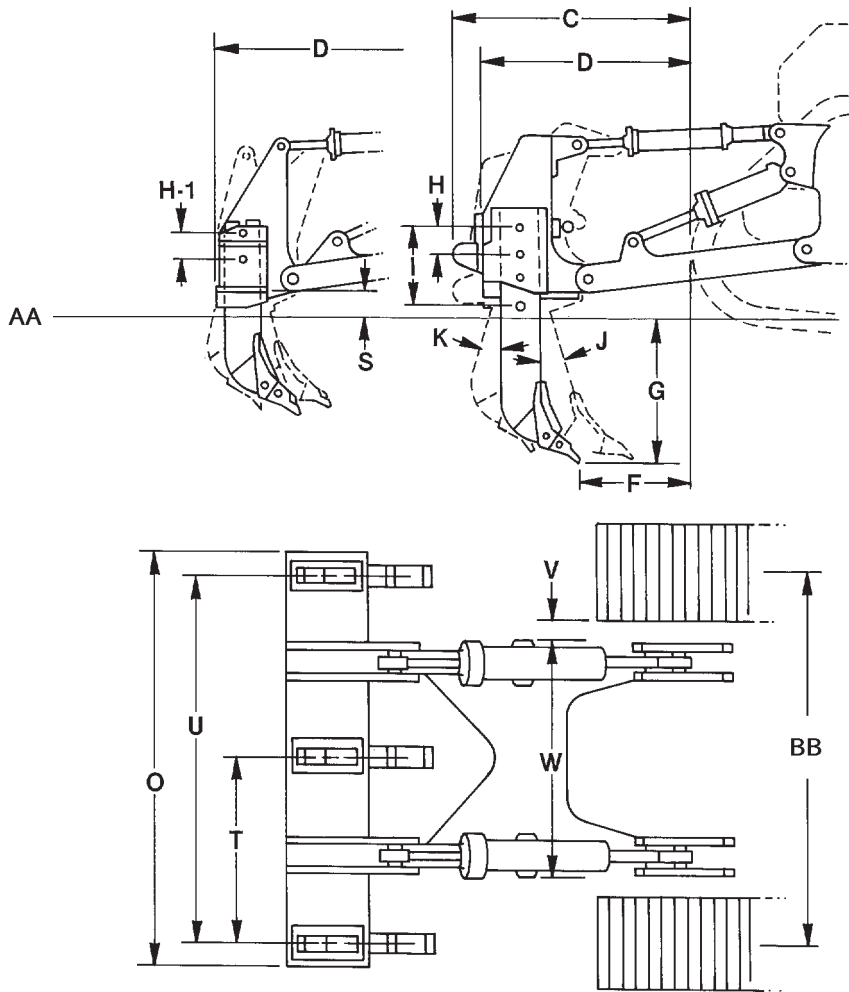

NOTE: Letters correspond to ripper specifications on pages that follow.

KEY

- AA — Ground Line
- BB — Track Gauge

Rippers

Specification Diagrams

- Radial Ripper
- Fixed Parallelogram Ripper

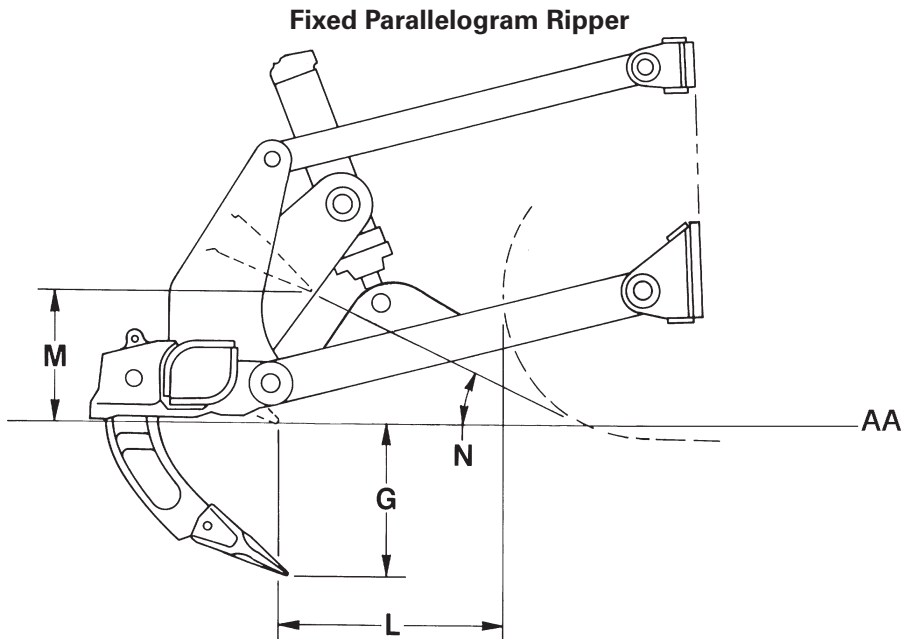
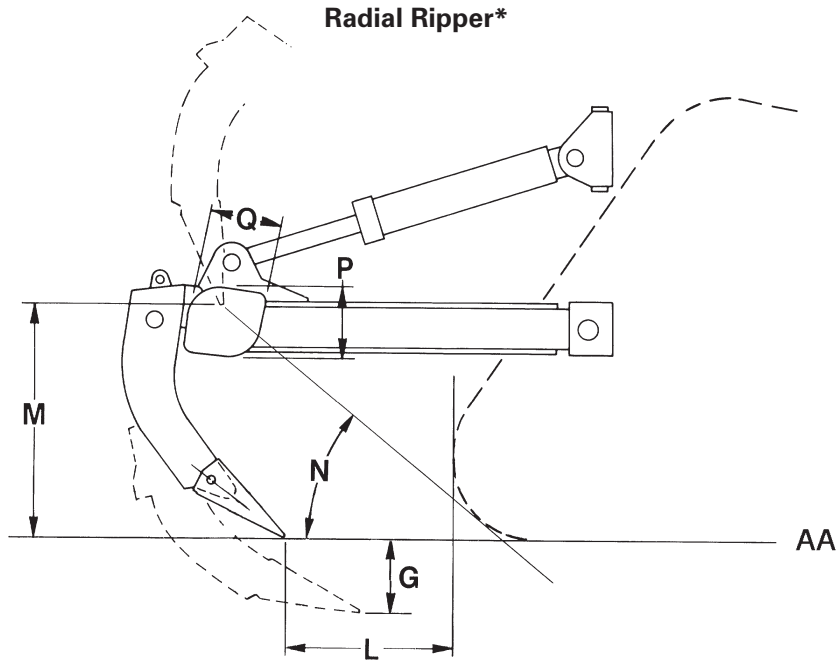

NOTE: Letters correspond to ripper specifications on pages that follow.

KEY

- AA — Ground Line
- * — Tip Standard

TRACTOR/RIPPER	D3K2**		D3K2		D4K2**	
Ripper Type	Fixed Parallelogram		Fixed Parallelogram		Fixed Parallelogram	
Dimensions:						
Ripper Shank						
G Maximum digging depth	338 mm	13.3"	338 mm	13.3"	338 mm	13.3"
L Maximum reach at ground line	766 mm	30.2"	766 mm	30.2"	596 mm	23.5"
M Maximum ground clearance under tip (shank pinned in bottom hole)	448 mm	17.6"	448 mm	17.6"	448 mm	17.6"
N Maximum ramp angle, ripper up (shank pinned in bottom hole)	27°		27°		32°	
Shank section	36 × 76 mm	1.4" × 3"	36 × 76 mm	1.4" × 3"	36 × 76 mm	1.4" × 3"
Ripper Beam						
O Overall width	1710 mm	67.3"	1710 mm	67.3"	1710 mm	67.3"
P Height	165 mm	6.5"	165 mm	6.5"	165 mm	6.5"
Q Length	190 mm	7.5"	190 mm	7.5"	190 mm	7.5"
Number of Pockets	3		3		3	
T Pocket Spacing	775 mm	30.5"	775 mm	30.5"	775 mm	30.5"
U Shank Gauge	1550 mm	61.0"	1.55 m	61.0"	1550 mm	61.0"
V Track clearance with standard shoe	80 mm	3.2"	80 mm	3.2"	80 mm	3.2"
Installed weights:						
Ripper with standard shank	554 kg	1222 lb	554 kg	1222 lb	554 kg	1222 lb
Ripper Forces:*						
Penetration Force	22.1 kN	4970 lb	22.1 kN	4970 lb	24.7 kN	5560 lb
Pryout Force	44.0 kN	9900 lb	44.0 kN	9900 lb	44.0 kN	9900 lb

TRACTOR/RIPPER	D4K2		D5K2**		D5K2	
Ripper Type	Fixed Parallelogram		Fixed Parallelogram		Fixed Parallelogram	
Dimensions:						
Ripper Shank						
G Maximum digging depth	338 mm	13.3"	338 mm	13.3"	338 mm	13.3"
L Maximum reach at ground line	766 mm	30.2"	555 mm	21.9"	766 mm	30.2"
M Maximum ground clearance under tip (shank pinned in bottom hole)	448 mm	17.6"	448 mm	17.6"	448 mm	17.6"
N Maximum ramp angle, ripper up (shank pinned in bottom hole)	27°		33°		27°	
Shank section	36 × 76 mm	1.4" × 3"	36 × 76 mm	1.4" × 3"	36 × 76 mm	1.4" × 3"
Ripper Beam						
O Overall width	1710 mm	67.3"	1710 mm	67.3"	1710 mm	67.3"
P Height	165 mm	6.5"	165 mm	6.5"	165 mm	6.5"
Q Length	190 mm	7.5"	190 mm	7.5"	190 mm	7.5"
Number of Pockets	3		3		3	
T Pocket Spacing	775 mm	30.5"	775 mm	30.5"	775 mm	30.5"
U Shank Gauge	1.55 m	61.0"	1550 mm	61.0"	1.55 m	61.0"
V Track clearance with standard shoe	80 mm	3.2"	80 mm	3.2"	80 mm	3.2"
Installed weights:						
Ripper with standard shank	554 kg	1222 lb	554 kg	1222 lb	554 kg	1222 lb
Ripper Forces:*						
Penetration Force	22.1 kN	4970 lb	27.3 kN	6130 lb	22.1 kN	4970 lb
Pryout Force	44.0 kN	9900 lb	44.0 kN	9900 lb	44.0 kN	9900 lb

*This value may vary slightly with various vehicle configurations.

**Meets Tier 3/Stage IIIA/Japan 2006 (Tier 3) equivalent emission standards.

NOTE: Letters correspond to ripper dimension drawings.

TRACTOR/RIPPER	D5R2 XL/D5R2 LGP		D6K2 XL	
Ripper Type	Parallelogram		Fixed Parallelogram	
Dimensions:				
Ripper Shank				
G Maximum digging depth	355 mm	14.0"	355 mm	14.0"
L Maximum reach at ground line	516 mm	1'8.3"	725 mm	28.5"
M Maximum ground clearance under tip (shank pinned in bottom hole)	422 mm	16.6"	471 mm	18.5"
N Maximum ramp angle, ripper up (shank pinned in bottom hole)	21.4°		24.8°	
Ripper Beam				
O Overall width	2200 mm	7'3"	1951 mm	6'4.8"
P Height	216 mm	8.5"	165 mm	6.5"
Q Length	254 mm	10"	211 mm	8.3"
Number of Pockets	3		3	
T Pocket Spacing	1000 mm	3'3.4"	896 mm	2'11.3"
U Shank Gauge	2000 mm	6'7"	1792 mm	5'10.6"
V Track clearance with standard shoe	99 mm	3.9"	81 mm	3.2"
Installed weights:				
Ripper with standard shank	1406 kg	3100 lb	908 kg	2002 lb
Each additional shank	78 kg	172 lb	34 kg	75 lb
Ripper Forces:				
Penetration Force	51.6 kN	11,600 lb	43 kN	9666.8 lb
Pryout Force	211.2 kN	47,480 lb	170 kN	38,218 lb

NOTE: Letters correspond to ripper dimension drawings.

TRACTOR/RIPPER	D6K2 LGP		D6R2	
Ripper Type	Fixed Parallelogram		Parallelogram	
Dimensions:				
Ripper Shank				
G Maximum digging depth	355 mm	14.0"	495 mm	1'8"
L Maximum reach at ground line	725 mm	28.5"	733 mm	2'5"
M Maximum ground clearance under tip (shank pinned in bottom hole)	471 mm	18.5"	518 mm	1'8"
N Maximum ramp angle, ripper up (shank pinned in bottom hole)		24.8°		26°
Shank section		—	74 × 175 mm	2.9" × 6.9"
Ripper Beam				
O Overall width	1951 mm	6'4.8"	2.20 m	7'3"
P Height	165 mm	6.5"	216 mm	8.5"
Q Length	211 mm	8.3"	254 mm	10"
Number of Pockets		3		3
T Pocket Spacing	896 mm	2'11.3"	1000 mm	3'3"
U Shank Gauge	1792 mm	5'10.6"	2 m	6'7"
V Track clearance with standard shoe	89 mm	3.5"	120 mm	4.7"
Installed weights:				
Ripper with standard shank	845 kg	1863 lb	1508 kg	3324 lb
Each additional shank	34 kg	75 lb	73 kg	160 lb
Ripper Forces:*				
Penetration Force	46 kN	10,641 lb	65.6 kN	14,747 lb
Pryout Force	170 kN	38,218 lb	89.6 kN	20,140 lb

*D6R2 tractor equipped with ripper, OROPS, SU dozer and heavy duty track. Values may vary slightly with various configurations.

NOTE: Letters correspond to ripper dimension drawings.

TRACTOR/RIPPER	D6R2 XL		D6R2 LGP	
Ripper Type	Parallelogram		Parallelogram	
Dimensions:				
Ripper Shank				
G Maximum digging depth	495 mm	1'8"	445 mm	1'6"
L Maximum reach at ground line	733 mm	2'5"	586 mm	1'11"
M Maximum ground clearance under tip (shank pinned in bottom hole)	518 mm	1'8"	568 mm	1'10"
N Maximum ramp angle, ripper up (shank pinned in bottom hole)	26°		28.5°	
Shank section	74 × 175 mm	2.9" × 6.9"	74 × 175 mm	2.9" × 6.9"
Ripper Beam				
O Overall width	2.20 m	7'3"	2.20 m	7'3"
P Height	216 mm	8.5"	216 mm	8.5"
Q Length	254 mm	10"	254 mm	10"
Number of Pockets	3		3	
T Pocket Spacing	1000 mm	3'3"	1000 mm	3'3"
U Shank Gauge	2 m	6'7"	2 m	6'7"
V Track clearance with standard shoe	69 mm	2.7"	171 mm	6.7"
Installed weights:				
Ripper with standard shank	1508 kg	3324 lb	1508 kg	3324 lb
Each additional shank	73 kg	160 lb	73 kg	160 lb
Ripper Forces:*				
Penetration Force	65.6 kN	14,747 lb	65.6 kN	14,747 lb
Pryout Force	116.5 kN	20,140 lb	116.5 kN	20,140 lb

*Tractor equipped with ripper, OROPS, SU dozer and heavy duty track. Values may vary slightly with various configurations.

NOTE: Letters correspond to ripper dimension drawings.

TRACTOR/RIPPER	D6T XL**		D6T XW**		D6T LGP**	
Ripper Type	Parallelogram		Parallelogram		Parallelogram	
Dimensions:						
Ripper Shank						
G Maximum digging depth	495 mm	1'8"	495 mm	1'8"	445 mm	1'6"
VPAT	495 mm	1'8"	445 mm	1'6"	445 mm	1'6"
L Maximum reach at ground line	733 mm	2'5"	733 mm	2'5"	586 mm	1'11"
VPAT	733 mm	2'5"	586 mm	1'11"	586 mm	1'11"
M Maximum ground clearance under tip (shank pinned in bottom hole)	518 mm	1'8"	518 mm	1'8"	568 mm	1'10"
VPAT	518 mm	1'8"	568 mm	1'10"	568 mm	1'10"
N Maximum ramp angle, ripper up (shank pinned in bottom hole)		26°		26°		28.5°
VPAT		26°		28.5°		28.5°
Shank section	74 × 175 mm	2.9" × 6.9"	74 × 175 mm	2.9" × 6.9"	74 × 175 mm	2.9" × 6.9"
Ripper Beam						
O Overall width	2.20 m	7'3"	2.20 m	7'3"	2.20 m	7'3"
P Height	216 mm	8.5"	216 mm	8.5"	216 mm	8.5"
Q Length	254 mm	10"	254 mm	10"	254 mm	10"
Number of Pockets		3		3		3
T Pocket Spacing	1000 mm	3'3"	1000 mm	3'3"	1000 mm	3'3"
U Shank Gauge	2 m	6'7"	2 m	6'7"	2 m	6'7"
V Track clearance with standard shoe	120 mm	4.7"	69 mm	2.7"	171 mm	6.7"
VPAT	374 mm	1'3"	374 mm	1'3"	374 mm	1'3"
Installed weights:						
Ripper with standard shank	1508 kg	3324 lb	1508 kg	3324 lb	1508 kg	3324 lb
Each additional shank	73 kg	160 lb	73 kg	160 lb	73 kg	160 lb
Ripper Forces:*						
Penetration Force	15.6 kN	3,507 lb	67.7 kN	15,220 lb	72.4 kN	16,276 lb
Pryout Force	116.5 kN	26,190 lb	116.5 kN	26,190 lb	116.5 kN	26,190 lb

*Tractor equipped with ripper, cab, SU dozer, and standard track.

**Meets Tier 4 Final/Stage IV/Japan 2014 (Tier 4 Final) emission standards.

NOTE: Letters correspond to ripper dimension drawings.

TRACTOR/RIPPER	D7R	
Ripper Type	Adjustable Parallelogram	
Dimensions:		
Ripper Shank		
G Maximum digging depth	748 mm	2'5.4"
L Maximum reach at ground line	1.07 m	3'6.1"
M Maximum ground clearance under tip (shank pinned in bottom hole)	638 mm	2'1.1"
N Maximum ramp angle, ripper up (shank pinned in bottom hole)	26.6°	
Shank section	72 × 228 mm	2.8" × 6.9"
Ripper Beam		
O Overall width	2.21 m	7'3"
P Height	279 mm	11"
Q Length	343 mm	13.5"
Number of Pockets	3	
T Pocket Spacing	991 mm	3'3"
U Shank Gauge	1.98 m	6'6"
V Track clearance with standard shoe	95 mm	3.7"
Installed weights:		
Ripper with standard shank	3277 kg	7225 lb
Each additional shank	138 kg	305 lb
Ripper Forces:*		
Penetration Force	85.0 kN	19,104 lb
Pryout Force	176.6 kN	39,705 lb

*Tractor equipped with ripper, OROPS, SU dozer and heavy duty track. Values may vary slightly with various configurations.

NOTE: Letters correspond to ripper dimension drawings.

TRACTOR/RIPPER	D7E		D8R/D8T			
	Adjustable Parallelogram		Adjustable Parallelogram			
Ripper Type	Multi-shank		Single Shank		Multi-shank	
Dimensions:						
Ripper to Track						
Ripper length behind track, shank vertical, ripper up						
A With Pushblock	N/A		N/A		N/A	
B Without Pushblock	1222 mm	4'0"	1.69 m	5'7"	1.6 m	5'2"
Ripper length behind track, shank vertical, ripper down						
C With Pushblock	N/A		N/A		N/A	
D Without Pushblock	1660 mm	5'5"	1.84 m	6'0"	1.71 m	5'7"
Tip to track distance, shank vertical						
E Ripper Up	614 mm	2'0"	694 mm	2'3.3"	640 mm	2'1.2"
F Ripper Down	970 mm	3'2"	950 mm	3'1.4"	899 mm	2'11.4"
Ripper Shank*						
G Maximum digging depth	650 mm	2'2"	1130 mm	3'8.5"	780 mm	2'6.7"
H Dig adjustment per hole	230 mm	9"	305 mm	12"	250 mm	10"
I Total dig adjustment	230 mm	9"	610 mm	2'0"	250 mm	10"
Pitch Adjustment, ripper down:						
J Forward	16°		15°		14.9°	
K Backward	12°		9.9°		10°	
L Maximum reach at ground line	1156 mm	3'10"	1.32 m	4'3"	1.17 m	3'10"
M Maximum ground clearance under tooth (shank pinned in bottom hole)	588 mm	1'11"	636 mm	2'1"	593 mm	1'11.3"
N Maximum ramp angle, ripper up (shank pinned in bottom hole)	26°		28.2°		28.4°	
Shank Section						
	72 × 228 mm	2.8" × 9.0"	75 × 333 mm	2.9" × 13.1"	75 × 333 mm	2.9" × 13.1"
Ripper Beam						
O Overall width	2088 mm	6'10"	N/A		2.46 m	8'1"
P Height**	355.6 mm	14" (dia)	N/A		334 mm	13.1"
Q Length**	—		N/A		457 mm	18"
Clearance under beam, shank vertical						
R Ripper Up	1080 mm	3'7"	N/A		1.55 m	5'1"
S Ripper Down	145 mm	5.7"	N/A		449 mm	17.7"
Number of Pockets						
T Pocket Spacing	900 mm	2'11"	N/A		1092 mm	3'7"
U Shank Gauge	1800 mm	5'11"	N/A		2.17 m	7'1"
V Track Clearance with standard shoe	47 mm	1.9"	76 mm	3"	76 mm	3"
W Width across widest part of lift cylinders	1275 mm	4'2"	1.37 m	4'5"	1.37 m	4'5"
Installed Weights:						
Ripper with standard shank						
	1650 kg	3572 lb	4085 kg	9005 lb	4213 kg	9287 lb
Each additional tooth group						
	150 kg	330 lb	N/A		332 kg	730 lb
Ripper Forces:***						
Penetration Force, shank vertical						
	87.4 kN	19,639 lb	127.4 kN	28,620 lb	124.2 kN	27,920 lb
Pryout Force, shank vertical						
	234.4 kN	52,695 lb	222.8 kN	50,070 lb	227.9 kN	51,230 lb

*Deep Ripping Shank is available for D8R/D8T single shank rippers. Hydraulic pin puller is standard with deep ripping shank. Deep Ripping Arrangement maximum digging depth is 1.57 m (5'2") for D8R/D8T.

**D7E ripper beam circular cross section.

***Forces for D7E are for machine equipped with SU-blade and standard track. Forces for D8R/D8T are for a ripper on a tractor equipped with EROPS, U-Dozer and performance track. Forces will vary slightly with other vehicle configurations.

NOTE: Letters correspond to ripper dimension drawings.

TRACTOR/RIPPER

D9R/D9T

Ripper Type	Adjustable Parallelogram			
	Single Shank		Multi-shank	
Dimensions:				
Ripper to Track				
Ripper length behind track, shank vertical, ripper up				
A With Pushblock		N/A		N/A
B Without Pushblock	1.57 m	5'2"	1.33 m	4'4"
Ripper length behind track, shank vertical, ripper down				
C With Pushblock		N/A		N/A
D Without Pushblock	1.88 m	6'2"	1.71 m	5'7"
Tip to track distance, shank vertical				
E Ripper Up	689 mm	2'3.2"	510 mm	1'8.1"
F Ripper Down	944 mm	3'1.2"	890 mm	2'11"
Ripper Shank*				
G Maximum digging depth	1231 mm	4'0.6"	798 mm	2'7.6"
H Dig adjustment per hole	295 mm	12"	250 mm	10"
I Total dig adjustment	590 mm	1'11.2"	250 mm	10"
Pitch Adjustment, ripper down:				
J Forward		10.6°		10°
K Backward		15.2°		15.1°
L Maximum reach at ground line	1.25 m	4'1"	1.16 m	3'10"
M Maximum ground clearance under tooth (shank pinned in bottom hole)	882 mm	2'10.9"	879 mm	2'10.6"
N Maximum ramp angle, ripper up (shank pinned in bottom hole)		36.9°		37.5°
Shank Section	90 × 355 mm	3.5" × 14"	75 × 332 mm	2.9" × 13.1"
Ripper Beam				
O Overall width		N/A	2.64 m	8'8"
P Height		N/A	380 mm	15"
Q Length		N/A	457 mm	18"
Clearance under beam, shank vertical				
R Ripper Up		N/A	1.77 m	5'10"
S Ripper Down		N/A	393 mm	15.5"
Number of Pockets				
T Pocket Spacing		1		3
U Shank Gauge		N/A	1176 mm	3'10.3"
V Track Clearance with standard shoe	71 mm	2.8"	2.35 m	7'8"
W Width across widest part of lift cylinders	1.50 m	4'11"	71 mm	2.8"
Installed Weights:				
Ripper with standard shank	4293 kg	9464 lb	1.50 m	4'11"
Each additional tooth group		N/A	4153 kg	9156 lb
			347 kg	765 lb
Ripper Forces:**				
Penetration Force, shank vertical	158 kN	35,520 lb	154 kN	34,621 lb
Pryout Force, shank vertical	332 kN	74,637 lb	361 kN	81,156 lb

*Deep Ripping Shank is available for D9R/D9T single shank rippers. Hydraulic pin puller is standard with deep ripping shank. Deep Ripping Arrangement maximum digging depth is 1.66 m (5'5") for D9R/D9T.

**Forces are for a ripper on a tractor equipped with EROPS, U-Dozer and performance track. Forces will vary slightly with other vehicle configurations.

NOTE: Letters correspond to ripper dimension drawings.

TRACTOR/RIPPER	D10T2		D11T		D11T	
	Adjustable Parallelogram		Adjustable Parallelogram		Adjustable Parallelogram	
Ripper Type	Single Shank	Multi-shank	Single Shank	CD Single Shank	Single Shank	CD Single Shank
Dimensions:						
Ripper to Track						
Ripper length behind track, shank vertical, ripper up (A)						
A With Pushblock	2.08 m 6'10"	N/A	2.29 m 7'6"	N/A		
B Without Pushblock	1.76 m 5'9"	1.56 m 5'1"	1.97 m 6'6"	2.26 m 7'5"		
Ripper length behind track, shank vertical, ripper down (A)						
C With Pushblock	2.48 m 8'2"	N/A	2.71 m 8'11"	N/A		
D Without Pushblock	2.16 m 7'1"	1.96 m 6'5"	2.39 m 7'10"	2.52 m 8'3"		
Tip to track distance, shank vertical (A)						
E Ripper Up*	730 mm 2'4.7"	651 mm 2'1.6"	751 mm 2'6"	751 mm 2'6"	751 mm 2'6"	751 mm 2'6"
F Ripper Down**	1130 mm 3'8.5"	1050 mm 3'5.3"	1174 mm 3'10"	1174 mm 3'10"	1174 mm 3'10"	1174 mm 3'10"
Ripper Shank***						
G Maximum digging depth**	1504 mm 4'11"	950 mm 3'1.4"	1612 mm 5'3"	1612 mm 5'3"	1612 mm 5'3"	1612 mm 5'3"
H Dig adjustment per hole	355 mm 14"	250 mm 10"	280 mm 11"	280 mm 11"	280 mm 11"	280 mm 11"
I Total dig adjustment	710 mm 2'4"	250 mm 10"	840 mm 2'9.1"	840 mm 2'9.1"	840 mm 2'9.1"	840 mm 2'9.1"
Pitch Adjustment, ripper down:						
J Forward	15.4°	18.1°	15°	13°		
K Backward	29.7°	23.2°	31.9°	31.9°		
L Maximum reach at ground line**	1.60 m 5'3"	1.39 m 4'7"	1.87 m 6'2"	1.87 m 6'2"	1.87 m 6'2"	1.87 m 6'2"
M Maximum ground clearance under tooth (shank pinned in bottom hole)	912 mm 3'0"	1055 mm 3'5.5"	1111 mm 3'9.7"	1115 mm 3'8"	1115 mm 3'8"	1115 mm 3'8"
N Maximum ramp angle, ripper up (shank pinned in bottom hole)	35.7°	50.9°	34.1°	34.1°		
Shank Section						
	100 × 400 mm (4" × 15.75")	90 × 355 mm (3.5" × 14")	110 × 450 mm (4.3" × 17.7")	110 × 450 mm (4.3" × 17.7")	110 × 450 mm (4.3" × 17.7")	110 × 450 mm (4.3" × 17.7")
Ripper Beam						
O Overall width	N/A	2.92 m 9'7"	N/A	N/A	N/A	N/A
P Height	N/A	468 mm 18.4"	N/A	N/A	N/A	N/A
Q Length	N/A	485 mm 19.1"	N/A	N/A	N/A	N/A
Clearance under beam, shank vertical						
R Ripper Up	N/A	2.03 m 6'8"	N/A	N/A	N/A	N/A
S Ripper Down	N/A	380 mm 15"	N/A	N/A	N/A	N/A
Number of Pockets						
	1	3	1	1	1	1
T Pocket Spacing	N/A	1320 mm 4'4"	N/A	N/A	N/A	N/A
U Shank Gauge	N/A	2.63 m 8'8"	N/A	N/A	N/A	N/A
V Track Clearance with standard shoe	97 mm 4"	97 mm 4"	141 mm 5.6"	141 mm 5.6"	141 mm 5.6"	141 mm 5.6"
W Width across widest part of lift cylinders	1.75 m 5'9"	1.75 m 5'9"	1.90 m 6'3"	1.90 m 6'3"	1.90 m 6'3"	1.90 m 6'3"
Installed Weights:						
Ripper with standard shank						
	6445 kg 14,209 lb	6132 kg 13,519 lb	8817 kg 19,438 lb	12 461 kg 27,472 lb	12 461 kg 27,472 lb	12 461 kg 27,472 lb
Each additional tooth group						
	N/A	544 kg 1200 lb	N/A	N/A	N/A	N/A
Ripper Forces:****						
Penetration Force, shank vertical						
	219 kN 49,233 lb	208 kN 46,760 lb	350 kN 78,683 lb	381 kN 85,652 lb	381 kN 85,652 lb	381 kN 85,652 lb
Pryout Force, shank vertical						
	512 kN 115,102 lb	515 kN 115,777 lb	638 kN 143,428 lb	629 kN 141,405 lb	629 kN 141,405 lb	629 kN 141,405 lb

*With Standard Shank pinned in the bottom hole.

**With Standard Shank pinned in the top hole.

***Deep Ripping Shank is available for the D10T2 and D11T single shank rippers. Deep Ripping Arrangement maximum digging depth is 1.80 m (5'11") for the D10T2 and 2.17 m (7'1") for the D11T.

****Forces are for a ripper on a tractor equipped with an EROPS, U-Dozer and performance track. Forces will vary slightly with other machine configurations. All dimensions are approximate.

TRACTOR/RIPPER	D11T		D11T	
	Adjustable Parallelogram			
Ripper Type	Multi-shank		CD Multi-shank	
Dimensions:				
Ripper to Track				
Ripper length behind track, shank vertical, ripper up (A)				
A With Pushblock		N/A		N/A
B Without Pushblock	1.69 m	5'6"	1.71 m	5'8"
Ripper length behind track, shank vertical, ripper down (A)				
C With Pushblock		N/A		N/A
D Without Pushblock	2.16 m	7'1"	2.16 m	7'1"
Tip to track distance, shank vertical (A)				
E Ripper Up	0.78 m	2'7"	0.78 m	2'7"
F Ripper Down	1.95 m	6'5"	1.96 m	6'5"
Shank*				
G Maximum digging depth	1100 mm	3'7.3"	1100 mm	3'7.3"
H Dig adjustment per hole	280 mm	11"	280 mm	11"
I Total dig adjustment	280 mm	11"	280 mm	11"
Pitch Adjustment, ripper down:				
J Forward		12.2°		12.2°
K Backward		31.8°		31.8°
L Maximum reach at ground line	1.71 m	5'7"	1.71 m	5'7"
M Maximum ground clearance under tooth (shank pinned in bottom hole)				
	1090 mm	3'6.9"	1090 mm	3'6.9"
N Maximum ramp angle, ripper up (shank pinned in bottom hole)				
		36.4°		36.4°
Shank Section				
	100 × 400 mm	3.9" × 15.7"	100 × 400 mm	3.9" × 15.7"
Ripper Beam				
O Overall width	3.33 m	10'11"	3.34 m	10'11.5"
P Height	560 mm	22"	595 mm	23.4"
Q Length	560 mm	22"	595 mm	23.4"
Clearance under beam, shank vertical				
R Ripper Up	2.06 m	6'9"	2.03 m	6'8"
S Ripper Down	282 mm	11.1"	247 mm	9.7"
Number of Pockets				
		3		3
T Pocket Spacing	1.5 m	4'11"	1.5 m	4'11"
U Shank Gauge	3.0 m	9'10"	3.0 m	9'10"
V Track Clearance with standard shoe	166 mm	5.6"	166 mm	5.6"
W Width across widest part of lift cylinders	1.9 m	6'3"	1.9 m	6'3"
Installed Weights:				
Ripper with standard shank				
	8674 kg	19,123 lb	11 790 kg	25,993 lb
Each additional tooth group				
	689 kg	1519 lb	689 kg	1519 lb
Ripper Forces:**				
Penetration Force, shank vertical				
	335 kN	75,311 lb	365 kN	82,055 lb
Pryout Force, shank vertical				
	632 kN	142,079 lb	636 kN	142,978 lb

*Hydraulic pin puller is standard with deep ripping shank. Deep Ripping Arrangement maximum digging depth is 2.18 m (7'2").

**Forces are for a ripper on a tractor equipped with an EROPS, U-Dozer and performance track. Forces will vary slightly with other vehicle configurations.

TIP SELECTION FOR THE D8R/D8T, D9R/D9T, D10T2 AND D11T RIPPERS

Three tip configurations (short, intermediate and long) in two styles (centerline and penetration) are available for economical operation in a variety of conditions.

RECOMMENDED TIP USAGE

Short — Use in high impact conditions where breakage problems occur. The shorter the tip, the more it resists breakage.

Intermediate — Most effective in moderate impact conditions where abrasion is not excessive.

Long — Use in loose, abrasive materials where breakage is not a problem. Generally offers the most wear material.

Centerline vs Penetration

The materials being ripped and the tractor doing the ripping will both have an effect on which tip will do the best job. High density material requires a “penetration” tip. High impact material requires a “centerline” tip. The following is a general guide to tip application.

Ripping Condition	Tips to use		
	D8R/D8T D9R/D9T	D10T2	D11T
Tandem Tractors	Short	Short	Short
Single Shank and Multi-shank			
Extreme Duty	Int.	Short	Short
Medium Duty	Long	Int.	Int.
Abrasive Duty	Long	Long	Long

Always use the longest tip that will wear without excessive breakage. Different tips should be tried to determine the most economical.

ESTIMATING RIPPING PRODUCTION

Ripping costs must be compared to other methods of loosening the material — usually drilling and blasting — on a cost per ton or bank cubic yard basis. Thus, an accurate estimation of ripper production is needed to determine unit ripping costs.

There are three general methods of estimating ripping production:

1. The best method is to record the time spent ripping, then remove (using scrapers or loaders and trucks) and weigh the ripped material. The total weight divided by the time spent will give hourly production. If the contractor is paid by volume, then a density must be used and the accuracy is only as good as the density used. For payment by volume removed, method 2 may be desirable. Some care will be needed to assure that only ripped material is removed.
2. Another method is to cross-section the area and then record the time spent ripping. After the material has been removed, cross-section the area again to determine the volume of rock removed. The volume divided by the time spent ripping gives the ripping rate per minute or hour.
3. Timing the ripper over a measured distance is the least accurate method, but valuable for quick estimating on the job. An average cycle time should be determined from a number of timed cycles. Turn-around or back-up time must be included. Measure the average rip distance, rip spacing and depth of penetration. This data will give the volume per cycle from which the production in bank cubic yards can be calculated. Experience has shown results obtained from this method are about 10 to 20% higher than the more accurate method of cross-sectioning.

An example of the measured distance method for calculating ripper production is:

Data — D10T2 — No. 10 with one shank.

910 mm (36 in) between passes.

1.6 km/h (1 mph) average speed (including slippage and stalls).

Every 91 m (300 ft) requires 0.25 min to raise, pivot, turn, and lower again: 91 m (300 ft) = 1 pass.

610 mm (24 in) penetration.

Full time ripping (no pushing or dozing assignment).

Example of Estimating Production (Metric)

Time per pass:

1.6 km/h = 26.7 m/min. Then $\frac{91 \text{ m}}{26.7 \text{ m/min}} = 3.41 \text{ min};$

3.41 min + 0.25 min (turn time) = 3.66 min/pass.

If the operator works an average of 45 min per h, it is possible to make $= \frac{45}{3.66} = 12.3 \text{ passes per h}$

Volume ripped: $91 \text{ m} \times 0.9 \text{ m} \times 0.6 \text{ m} = 49.1 \text{ BCM}$ per pass

Production = $49.1 \times 12.3 = 604 \text{ BCM per h}$

Remember the results from this method are usually 10 to 20 per cent higher than the actual production that can be expected on the job.

Example of Estimating Production (English)

Time per pass:

MPH = 88 fpm. Then $\frac{300 \text{ ft}}{88 \text{ fpm}} = 3.41 \text{ min};$

3.41 min + 0.25 min. (turn time) = 3.66 min/pass.

If the operator works an average of 45 min per h, it is possible to make $= \frac{45}{3.66} = 12.3 \text{ passes per h}$

Volume ripped: $\frac{300 \times 3 \times 2}{27} = 66.7 \text{ BCY per pass}$

Production = $66.7 \times 12.3 = 820 \text{ BCY per hr}$



NOTE: The demands of heavy ripping will increase the normal owning and operating costs of the tractor.

These costs should be increased no less than 30-40% in heavy ripping applications to estimate rock loosening costs.

There is no ready answer or rule-of-thumb solution to predict ripping production. Even if everything is known about the seismic velocity of the material, its composition, job conditions, equipment and operator, only a "guesstimate" can be given. The final answer must come from a production study obtained on the job site.

Sample problem (Metric)

Determine the loosening costs in the following situation:

Machine	— D10T2 Tractor with No. 10 Single Shank Ripper
Rip Spacing	— 915 mm
Ripper Penetration	— 610 mm
Rip Distance	— 91 m
Rip Time	— 3.41 minutes
Maneuver Time	— 0.25 minutes
Seismic Velocity	— 1830 meters per second
Assume	60 min. hour

Solution:

1. Total Cycle Time = $3.41 + 0.25 = 3.66 \text{ min}$

$$\text{Cycles/hour} = \frac{60 \text{ min/hr}}{3.66 \text{ min/cycle}} = 16.4$$

2. Production per cycle = $91 \text{ m} \times 0.9 \text{ m} \times 0.6 \text{ m} = 49.1 \text{ BCM/cycle}$

3. Production = $49.1 \text{ BCM/cycle} \times 16.4 \text{ cycles/h} = 805 \text{ BCM/h}$

4. Remember results of this method are usually 10 to 20% high.

$$\begin{aligned} \text{Actual Production} &= 80\% \text{ of } 805 \text{ BCM/h} \\ &= 644 \text{ BCM/h} \end{aligned}$$

$$\text{Or } 90\% \text{ of } 805 \text{ BCM/h} = 725 \text{ BCM/h}$$

5. Owning and Operating Costs

A D10T2 (ripping only) could have a \$115.00/h O & O costs including \$30/h operator.

6. Loosening Costs

$$\$115.00/\text{hr} \div 644 \text{ BCM/h} = \$0.179/\text{BCM}$$

$$\$115.00/\text{hr} \div 725 \text{ BCM/h} = \$0.159/\text{BCM}$$

The loosening cost should range from 15.9¢ to 17.9¢/BCM

Sample problem (English)

Determine the loosening costs in the following situation:

Machine	— D10T2 Tractor with No. 10 Single Shank Ripper
Rip Spacing	— 3 feet
Ripper Penetration	— 2 feet
Rip Distance	— 300 feet
Rip Time	— 3.41 minutes
Maneuver Time	— 0.25 minutes
Seismic Velocity	— 6000 feet per second
Assume	60 min. hour

Solution:

1. Total Cycle Time = $3.41 + 0.25 = 3.66$ min

$$\text{Cycles/hour} = \frac{60 \text{ min/hr}}{3.66 \text{ min/cycle}} = 16.4$$
2. Production per cycle = $\frac{300 \times 3 \times 2}{27} = 66.7$ BCY/cycle
3. Production = $66.7 \text{ BCY/cycle} \times 16.4 \text{ cycles/hr} = 1094 \text{ BCY/hour}$
4. Remember results of this method are usually 10 to 20% high.

$$\begin{aligned} \text{Actual Production} &= 80\% \times 1094 \\ &= 875 \text{ BCY/hr} \\ \text{or } 90\% \times 1094 &= 984 \text{ BCY/hr} \end{aligned}$$
5. Owning and Operating Costs
 A D10T2 (ripping only) could have a \$115.00/hr
 O & O costs including \$30/hr operator
6. Loosening Costs

$$\begin{aligned} \$115.00/\text{hr} \div 875 \text{ BCY/hr} &= \$0.131/\text{BCY} \\ \$115.00/\text{hr} \div 984 \text{ BCY/hr} &= \$0.117/\text{BCY} \end{aligned}$$
 The loosening cost should range from 11.7¢ to 13.1¢/BCY



USE OF SEISMIC VELOCITY CHARTS

The charts of ripper performance estimated by seismic wave velocities have been developed from field tests conducted in a variety of materials. Considering the extreme variations among materials and even among rocks of a specific classification, the charts must be recognized as being at best only one indicator of rippability.

Accordingly, consider the following precautions when evaluating the feasibility of ripping a given formation:

- Tooth penetration is often the key to ripping success, regardless of seismic velocity. This is particularly true in homogeneous materials such as mudstones and claystones and the fine-grained caliches. It is also true in tightly cemented formations such as conglomerates, some glacial tills and caliches containing rock fragments.

- Low seismic velocities of sedimentaries can indicate probable rippability. However, if the fractures and bedding joints do not allow tooth penetration, the material may not be ripped effectively.
- Pre-blasting or “popping” may induce sufficient fracturing to permit tooth entry, particularly in the caliches, conglomerates and some other rocks; but the economics should be checked carefully when considering popping in the higher grades of sandstones, limestones and granites.

Ripping is still more art than science, and much will depend on operator skill and experience. Ripping for scraper loading may call for different techniques than if the same material is to be dozed away. Cross-ripping requires a change in approach. The number of shanks used, length and depth of shank, tooth angle, direction, throttle position — all must be adjusted according to field conditions. Ripping success may well depend on the operator finding the proper combination for those conditions.

D8R/D8T

● Multi- or Single Shank No. 8 Ripper

● Estimated by Seismic Wave Velocities

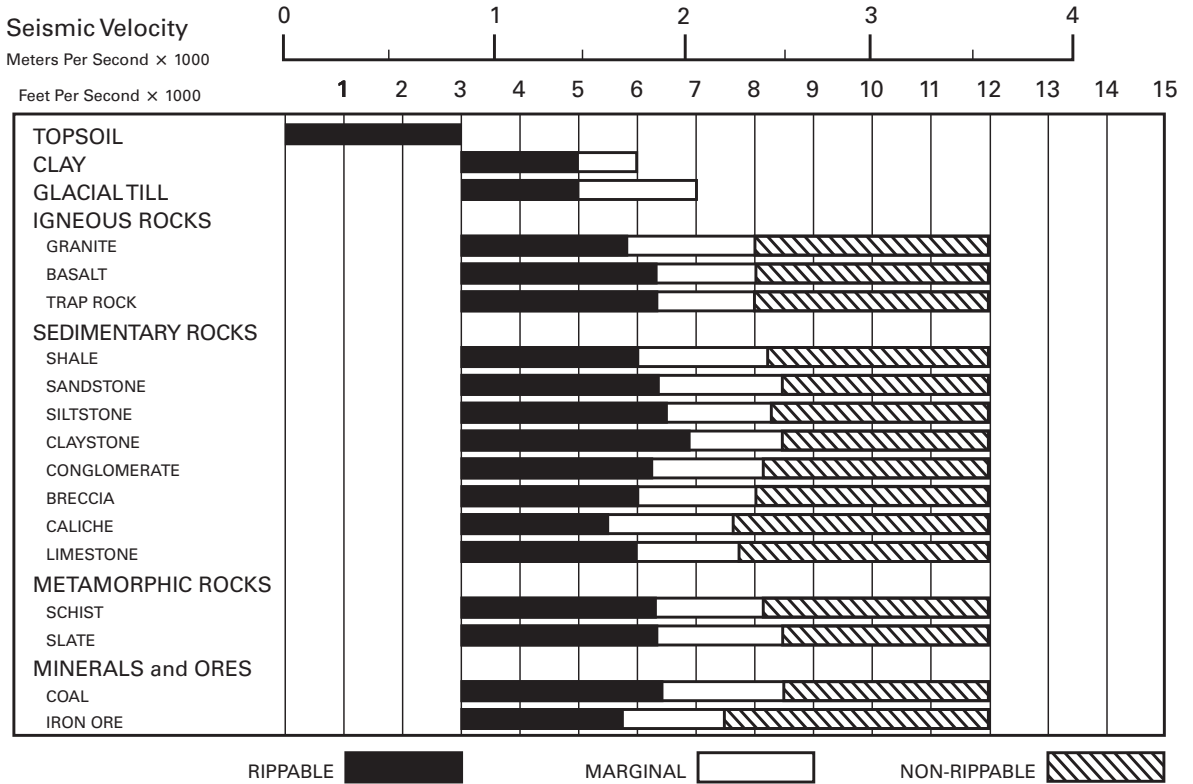

D9R/D9T

- Multi- or Single Shank No. 9 Ripper
- Estimated by Seismic Wave Velocities

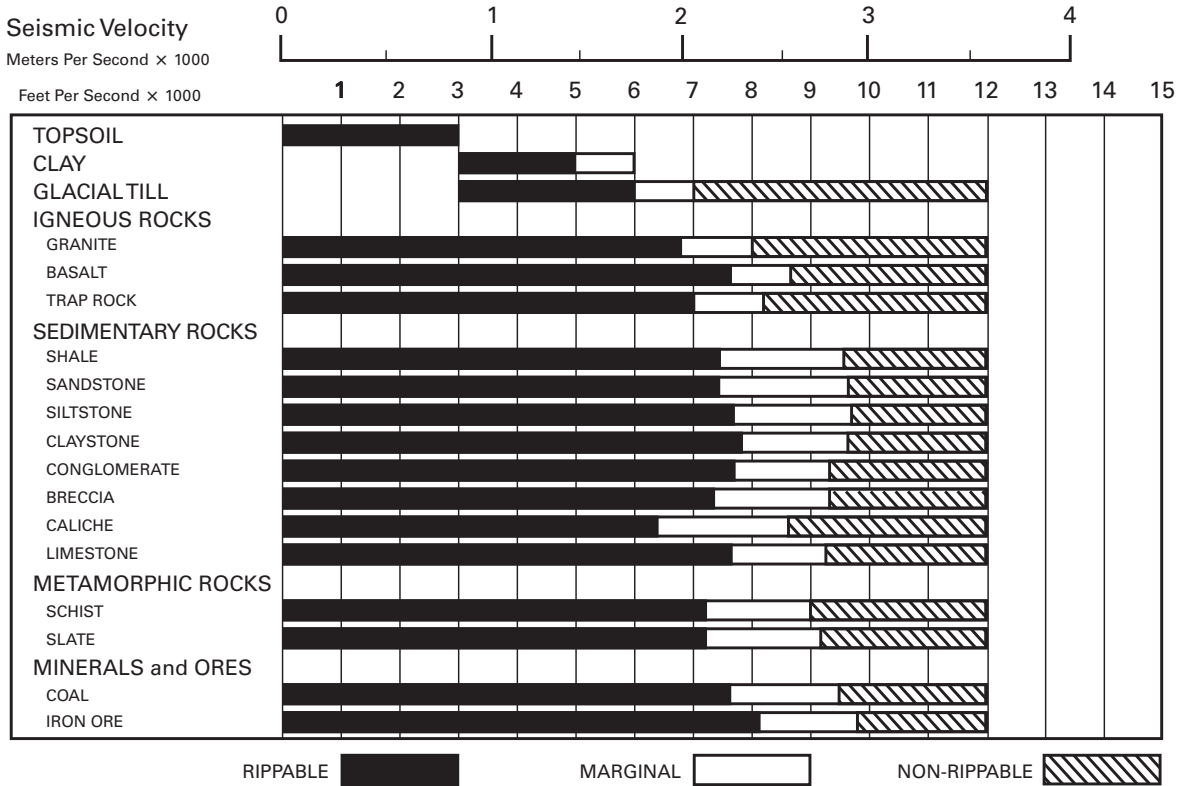

D10T2

● Multi- or Single Shank No. 10 Ripper

● Estimated by Seismic Wave Velocities

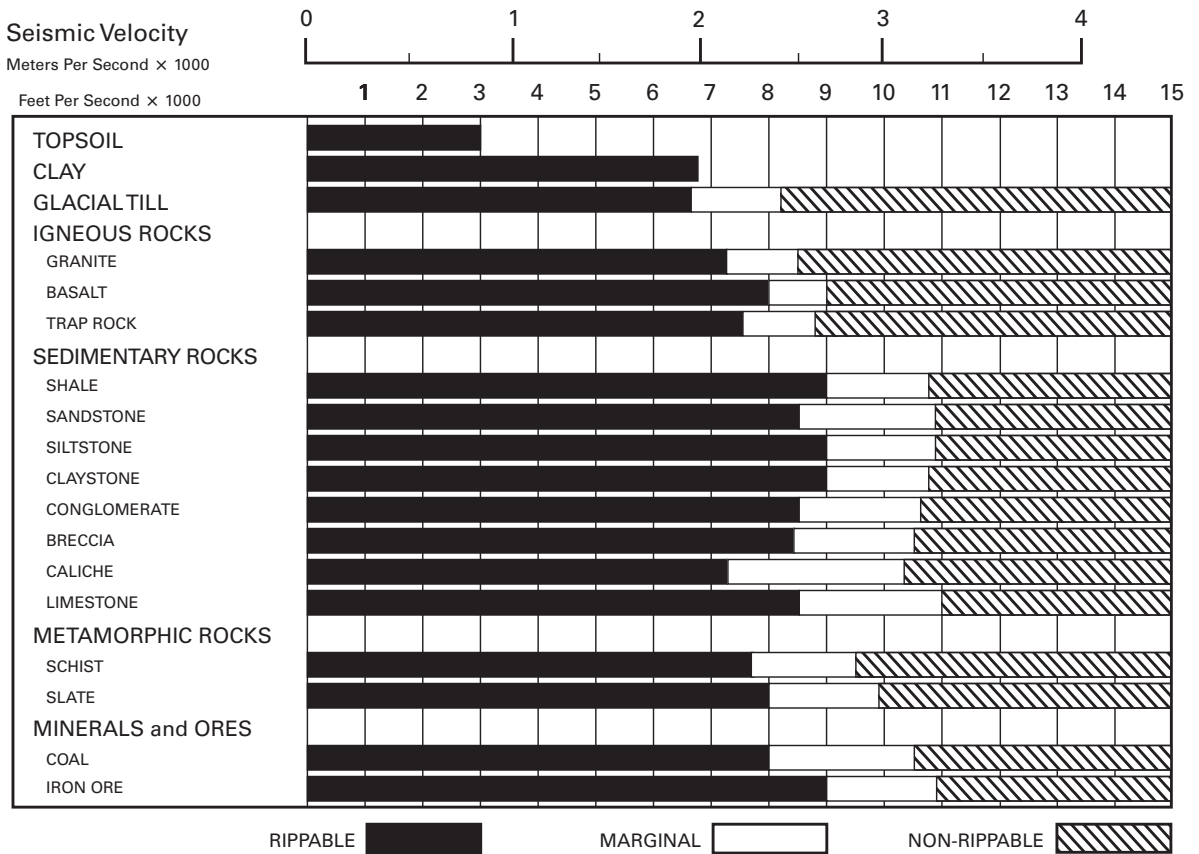

D11T

- Multi- or Single Shank No. 11 Ripper
- Estimated by Seismic Wave Velocities

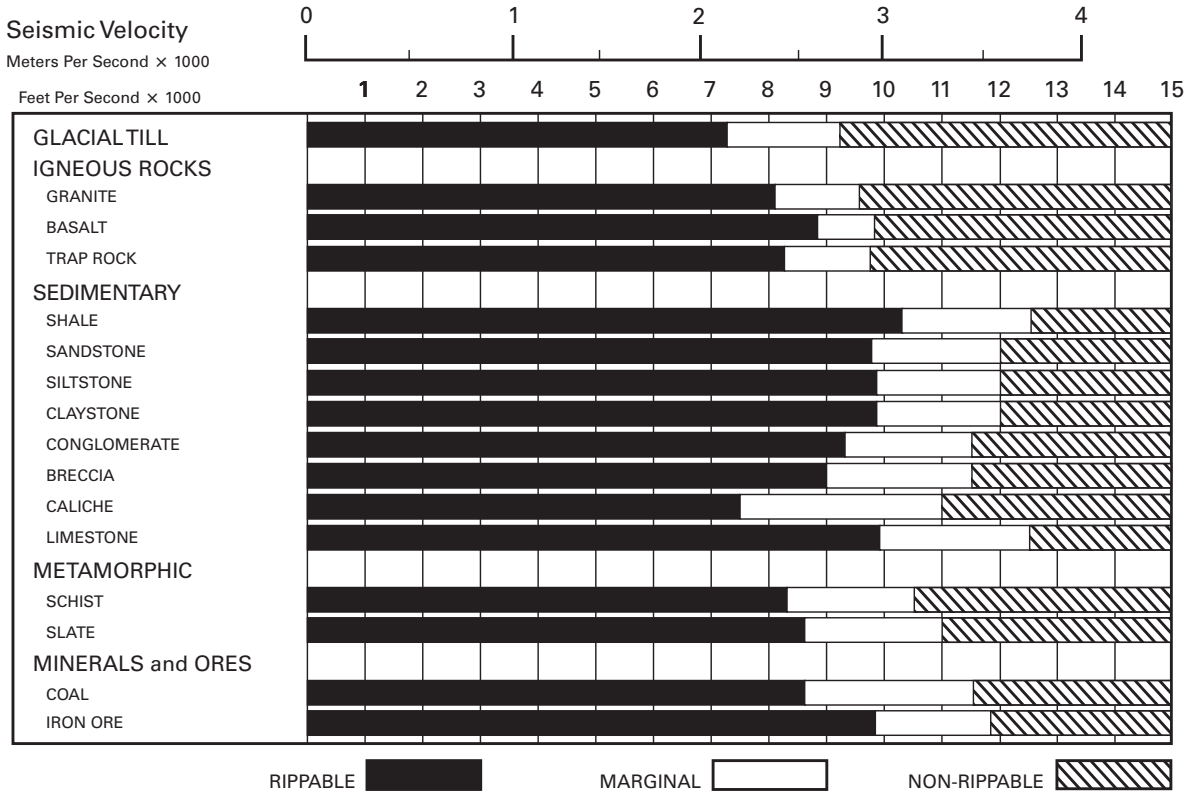

D11T CD

● **Single Shank No. 11 Ripper**

● **Estimated by Seismic Wave Velocities**

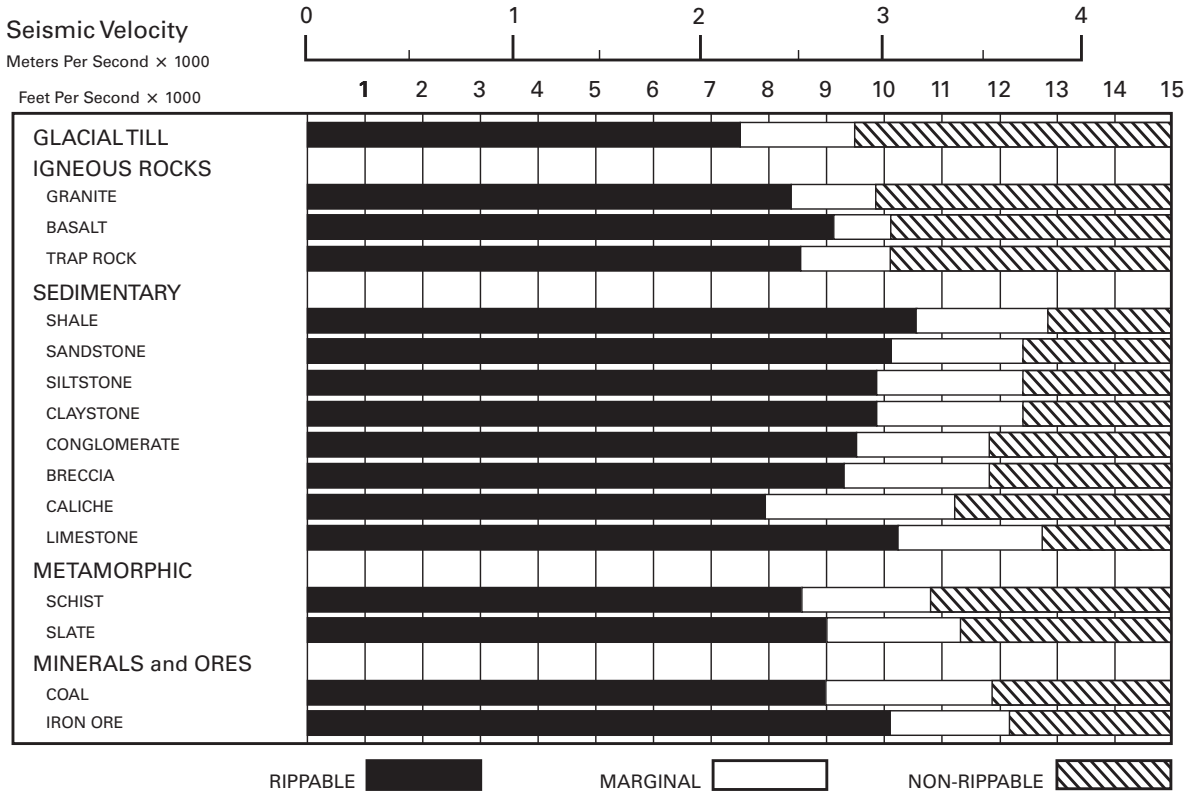

CONSIDERATIONS FOR USING PRODUCTION ESTIMATED GRAPHS:

- Machine rips full-time — no dozing.
- Power shift tractors with single shank rippers.
- 100% efficiency (60 min hour).
- Charts are for all classes of material.
- In igneous rock with seismic velocity of 8000 fps (2450 mps) or higher for the D11T, and 6000 fps (1830 mps) or higher for the D10T2, D9R/D9T and D8R/D8T, the production figures shown should be reduced by 25%.
- Upper limit of charts reflect ripping under ideal conditions only. If conditions such as thick lamination, vertical lamination or any factor which would adversely affect production are present, the lower limit should be used.

D8R/D8T WITH SINGLE SHANK

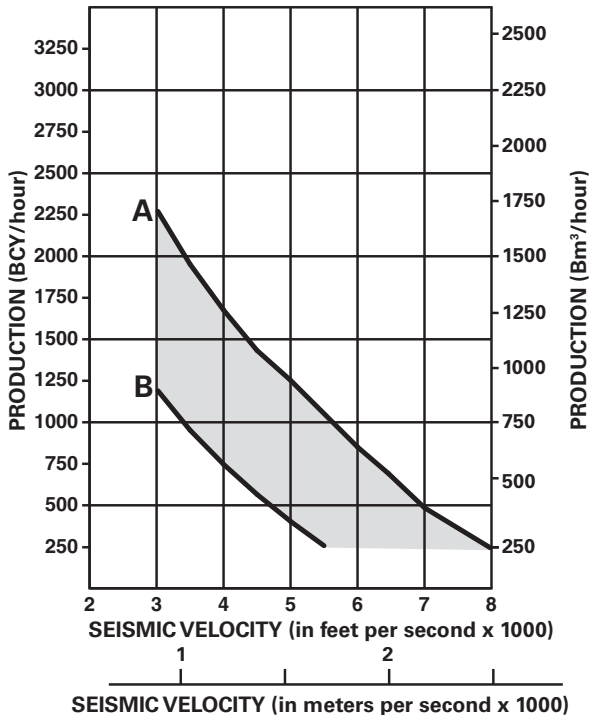

D9R/D9T WITH SINGLE SHANK

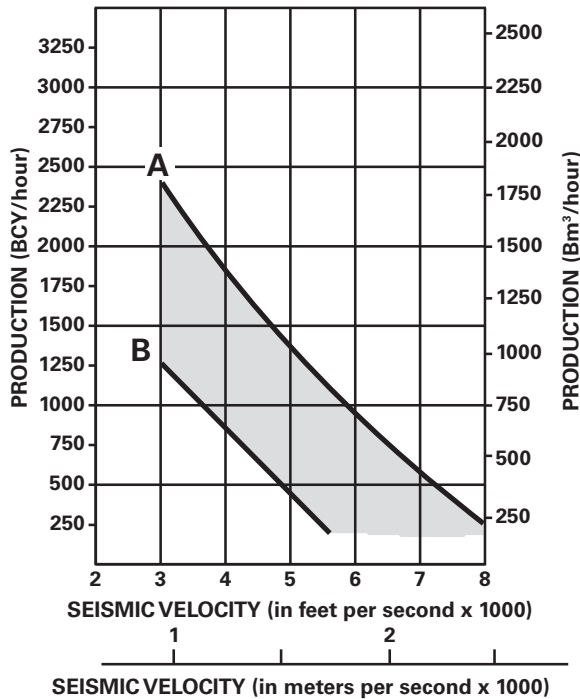

KEY

- A — IDEAL
- B — ADVERSE

D10T2 WITH SINGLE SHANK

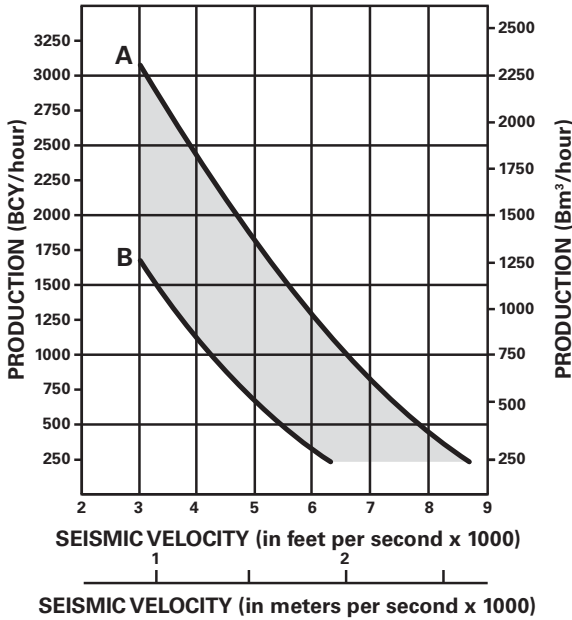

D11T WITH SINGLE SHANK

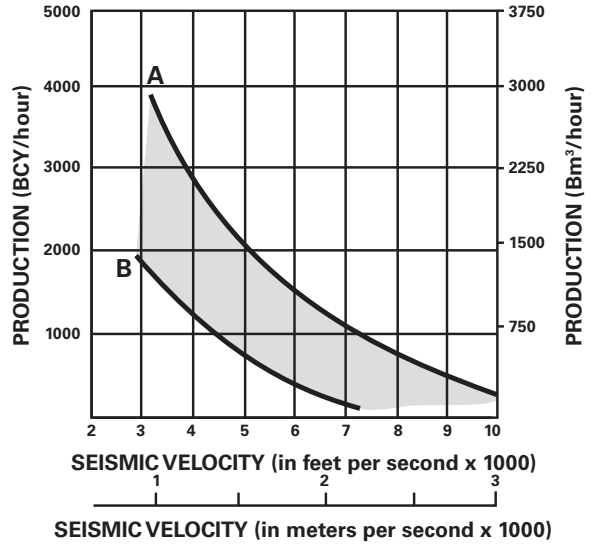

D11T CD WITH SINGLE SHANK

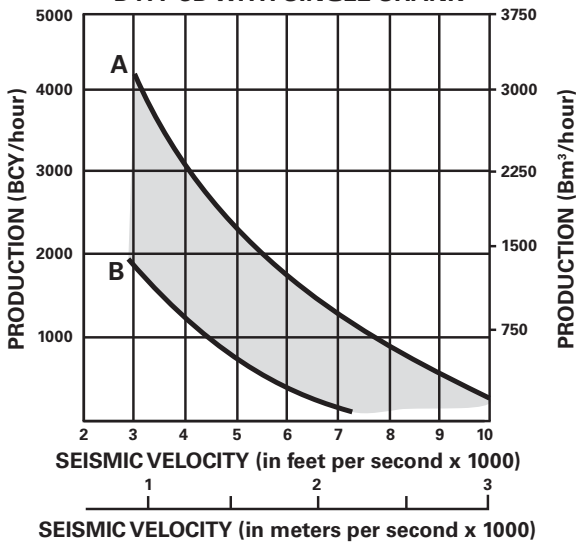

KEY

- A — IDEAL
- B — ADVERSE

WINCHES PACCAR ALLIED

CONTENTS

PACCAR

Features	19-84
Physical Specifications	19-85
Operating Specifications	19-95

Allied

Features	19-99
Physical Specifications	19-100
Operating Specifications	19-107

PACCAR Features:

PACCAR winches have been installed on Cat tractors since 1932. After acquiring the intellectual and property rights of Cat tail winches in the early 1990's, PACCAR Winch has exclusively supplied Caterpillar manufacturing facilities worldwide with tractor winches for factory installation.

PA40 and PA50

- **Closed loop hydrostatic operation** with variable displacement motor and dedicated variable displacement pump for maximum winching power and flexibility.
- **Infinitely variable control** of line speed and line pull including positive inching control at maximum rated line pull.
- **Standard full-function “power-in” and “power-out” control.** This is optional on some competitive winches.
- **Standard “drive-away”** to maintain tension on the cable when driving the tractor away from a stationary load.
- **Standard “free spool”** to allow cable to be pulled off the winch by hand.
- **Durable cast winch case** with fairlead mounting lugs, log arch mounting lugs, and heavy duty drawbar.

PA55, PA56 and PA80

- **PTO mechanical winch drive** with full tractor engine power available to the winch.
- **Self-contained internal hydraulic control system** for easy installation.
- **Equal speed gearing in “reel-in” and “reel-out”** to provide smooth and predictable performance.
- **Standard “drive-away”** to maintain tension on the cable when driving the tractor away from a stationary load.
- **Standard “free spool”** to allow cable to be pulled off the winch by hand.
- **Durable cast winch case** with fairlead mounting lugs, log arch mounting lugs, and heavy duty drawbar.

PA90, PA110B, PA140 and H200

- **Hydraulically driven winch** for infinitely variable control of line speed and line pull including positive inching control at maximum rated line pull.
- **Optimized “high power” hydraulic control system** including specialized directional control valve for maximum winching power and flexibility.
- **Dual braking system** provides a static brake with sprag clutch to eliminate fall-back and a hydraulic brake valve for dynamic braking.
- **Single lever joystick control** for ease of operation.
- **Fabricated steel winch case** with integral heavy duty drawbar provides excellent durability and easy weldability.
- **Standard three-roller fairlead** for improved wire rope life during side pulls.

H60, H110B and H140

- **Hydraulically driven winch** for infinitely variable control of line speed and line pull including positive inching control at maximum rated line pull.
- **Standard Cat ripper control system** is employed for winch “power-in” and “power-out” functions.
- **Winch installation time is reduced by up to 70%** compared to “high power” installations.
- **Easy field interchangeability between winch and ripper.**
- **Dual braking system** provides a static brake with sprag clutch to eliminate fall-back and a hydraulic brake valve for dynamic braking.
- **Durable cast (H60) or fabricated steel (H110B and H140) winch case** with integral heavy duty drawbar.
- **Three-roller fairlead** for improved wire rope life during side pulls is standard on H110B and H140 and optional on H60.
- **“Free spool”** to allow cable to be pulled off the winch by hand is standard on H60.

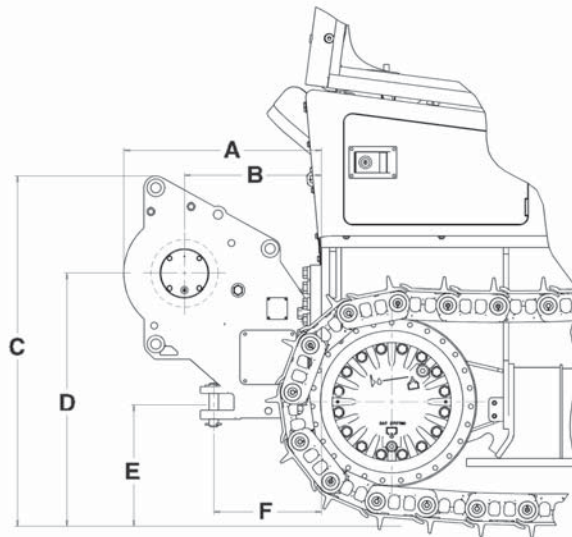

WINCH MODEL TRACTOR MODEL	PA40				PA50	
	D3K2, D4K2, D5K2 ⁵		D3K2, D4K2, D5K2		D6K2	
Tractor transmission	Hydrostatic		Hydrostatic		Hydrostatic	
Winch drive	Hydrostatic		Hydrostatic		Hydrostatic	
A Tractor to rear of winch	751 mm	29.6"	751 mm	29.6"	845 mm	33.2"
B Tractor to drum centerline	521 mm	20.5"	521 mm	20.5"	615 mm	24.2"
C Ground to top of winch	1327 mm	52.2"	1327 mm	52.2"	1380 mm	54.4"
D Ground to drum centerline	959 mm	37.8"	959 mm	37.8"	1010 mm	39.8"
E Ground to center of hitch	473 mm	18.6"	473 mm	18.6"	525 mm	20.7"
F Tractor to drawbar pin centerline	410 mm	16.1"	410 mm	16.1"	505 mm	19.8"
Winch width (not shown) ¹	740 mm	29.2"	740 mm	29.2"	740 mm	29.2"
Drum diameter (not shown)	255 mm	10.0"	255 mm	10.0"	205 mm	8.0"
Weight ²	610 kg	1345 lb	610 kg	1345 lb	610 kg	1345 lb
Oil refill capacity	4.3 L	4.5 qt	4.3 L	4.5 qt	4.3 L	4.5 qt
Wire rope diameter:						
Recommended	16 mm	0.63"	16 mm	0.63"	19 mm	0.75"
Optional	19 mm	0.75"	19 mm	0.75"	22 mm	0.88"
Maximum theoretical drum capacity: ³						
Recommended rope	114 m	374'	114 m	374'	93 m	306'
Optional rope	80 m	264'	80 m	264'	67 m	220'
Maximum recommended drum capacity: ⁴						
Recommended rope	83 m	272'	83 m	272'	62 m	203'
Optional rope	55 m	180'	55 m	180'	56 m	183'
Wire rope ferrule size (OD)	54 mm	2.13"	54 mm	2.13"	54 mm	2.13"
Wire rope ferrule size (length)	67 mm	2.63"	67 mm	2.63"	67 mm	2.63"

¹Width does not include mounting brackets/adapters (if any).

²Weight shown is base winch only. Does not include mounting arrangement, control arrangement, oil, or wire rope.

³Per SAE J1158.

⁴Per SAE J706 (K=9).

⁵Meets Tier 3/Stage IIIA/Japan 2006 (Tier 3) equivalent emission standards.

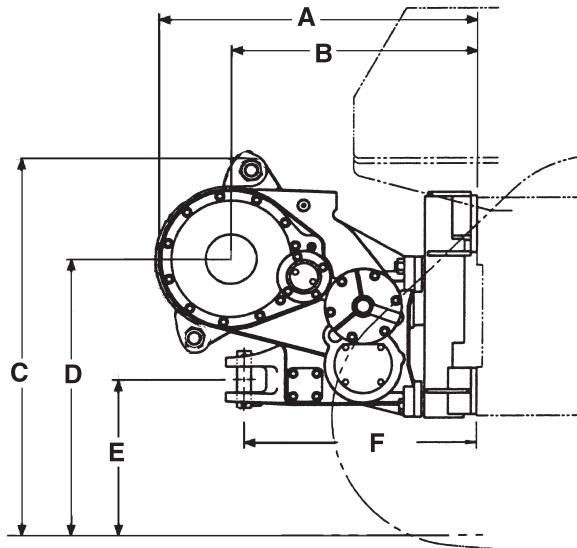

WINCH MODEL	PA55			
TRACTOR MODEL	D5R XL, D6N XL		D5R LGP, D6N LGP	
Tractor transmission	Powershift		Powershift	
Winch drive	PTO		PTO	
A Tractor to rear of winch	1145 mm	45.1"	1145 mm	45.1"
B Tractor to drum centerline	890 mm	35.1"	890 mm	35.1"
C Ground to top of winch	1330 mm	52.3"	1380 mm	54.3"
D Ground to drum centerline	960 mm	37.8"	1010 mm	39.8"
E Ground to center of hitch	525 mm	20.7"	575 mm	22.7"
F Tractor to drawbar pin centerline	845 mm	33.2"	845 mm	33.2"
Winch width (not shown) ¹	975 mm	38.3"	975 mm	38.3"
Drum diameter (not shown)	255 mm	10.0"	255 mm	10.0"
Weight ²	1180 kg	2600 lb	1180 kg	2600 lb
Oil refill capacity	74 L	19.5 U.S. gal	74 L	19.5 U.S. gal
Wire rope diameter:				
Recommended	19 mm	0.75"	19 mm	0.75"
Optional	22 mm	0.88"	22 mm	0.88"
Maximum theoretical drum capacity: ³				
Recommended rope	119 m	391'	119 m	391'
Optional rope	85 m	281'	85 m	281'
Maximum recommended drum capacity: ⁴				
Recommended rope	81 m	267'	81 m	267'
Optional rope	55 m	180'	55 m	180'
Wire rope ferrule size (OD)	54 mm	2.13"	54 mm	2.13"
Wire rope ferrule size (length)	67 mm	2.63"	67 mm	2.63"

¹Width does not include mounting brackets/adapters (if any).

²Weight shown is base winch only. Does not include mounting arrangement, control arrangement, oil, or wire rope.

³Per SAE J1158.

⁴Per SAE J706 (K=9).

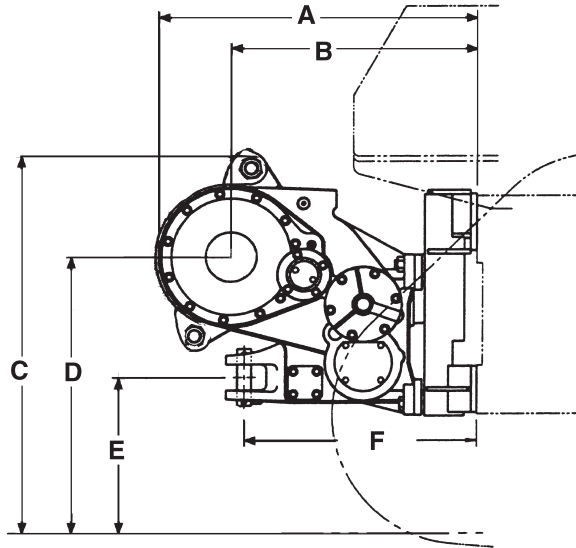

WINCH MODEL	H60			
TRACTOR MODEL	D5R XL, D6N XL		D5R LGP, D6N LGP	
Tractor transmission	Powershift		Powershift	
Winch drive	Hydraulic (Ripper)		Hydraulic (Ripper)	
A Tractor to rear of winch	1210 mm	47.7"	1210 mm	47.7"
B Tractor to drum centerline	945 mm	37.7"	945 mm	37.7"
C Ground to top of winch	1530 mm	60.2"	1640 mm	64.7"
D Ground to drum centerline	1160 mm	45.7"	1275 mm	50.2"
E Ground to center of hitch	725 mm	28.5"	762 mm	33.0"
F Tractor to drawbar pin centerline	910 mm	35.8"	910 mm	35.8"
Winch width (not shown) ¹	975 mm	38.3"	975 mm	38.3"
Drum diameter (not shown)	255 mm	10.0"	255 mm	10.0"
Weight ²	1180 kg	2600 lb	1180 kg	2600 lb
Oil refill capacity	67 L	17.75 U.S. gal	67 L	17.75 U.S. gal
Wire rope diameter:				
Recommended	22 mm	0.88"	22 mm	0.88"
Optional	26 mm	1.0"	26 mm	1.0"
Maximum theoretical drum capacity: ³				
Recommended rope	85 m	281'	85 m	281'
Optional rope	66 m	218'	66 m	218'
Maximum recommended drum capacity: ⁴				
Recommended rope	55 m	180'	55 m	180'
Optional rope	50 m	163'	50 m	163'
Wire rope ferrule size (OD)	54 mm	2.13"	54 mm	2.13"
Wire rope ferrule size (length)	67 mm	2.63"	67 mm	2.63"

¹Width does not include mounting brackets/adapters (if any).

²Weight shown is base winch only. Does not include mounting arrangement, control arrangement, oil, or wire rope.

³Per SAE J1158.

⁴Per SAE J706 (K=9).

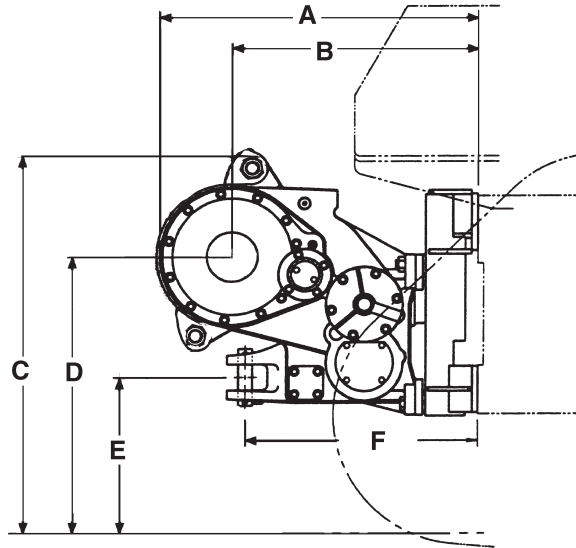

WINCH MODEL	PA56			
TRACTOR MODEL	D6R, D6R XL, D6T, D6T ⁵ XL, XL VPAT, XW		D6R LGP, D6T ⁵ XW VPAT, LGP, and LGP VPAT	
Tractor transmission	Powershift		Powershift	
Winch drive	PTO		PTO	
A Tractor to rear of winch	1210 mm	47.7"	1210 mm	47.7"
B Tractor to drum centerline	945 mm	37.7"	945 mm	37.7"
C Ground to top of winch	1530 mm	60.2"	1580 mm	62.2"
D Ground to drum centerline	1160 mm	45.7"	1210 mm	47.7"
E Ground to center of hitch	725 mm	28.5"	775 mm	30.5"
F Tractor to drawbar pin centerline	910 mm	35.8"	910 mm	35.8"
Winch width (not shown) ¹	975 mm	38.3"	975 mm	38.3"
Drum diameter (not shown)	255 mm	10.0"	255 mm	10.0"
Weight ²	1180 kg	2600 lb	1180 kg	2600 lb
Oil refill capacity	67 L	17.75 U.S. gal	67 L	17.75 U.S. gal
Wire rope diameter:				
Recommended	22 mm	0.88"	22 mm	0.88"
Optional	26 mm	1.0"	26 mm	1.0"
Maximum theoretical drum capacity: ³				
Recommended rope	85 m	281'	85 m	281'
Optional rope	66 m	218'	66 m	218'
Maximum recommended drum capacity: ⁴				
Recommended rope	55 m	180'	55 m	180'
Optional rope	50 m	163'	50 m	163'
Wire rope ferrule size (OD)	54 mm	2.13"	54 mm	2.13"
Wire rope ferrule size (length)	67 mm	2.63"	67 mm	2.63"

¹Width does not include mounting brackets/adapters (if any).

²Weight shown is base winch only. Does not include mounting arrangement, control arrangement, oil, or wire rope.

³Per SAE J1158.

⁴Per SAE J706 (K=9).

⁵Meets Tier 4 Final/Stage IV/Japan 2014 (Tier 4 Final) emission standards.

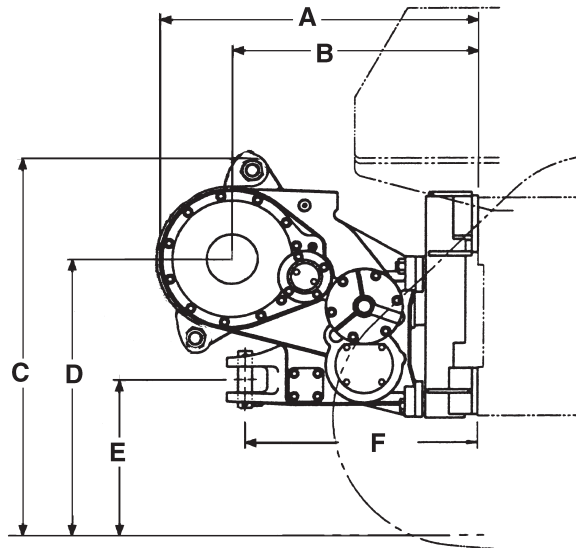

WINCH MODEL TRACTOR MODEL	H85			
	D6T ⁵ XL, XL VPAT, and XW		D6T ⁵ XW VPAT, LGP, and LGP VPAT	
Tractor transmission	Powershift		Powershift	
Winch drive	Hydraulic (Ripper)		Hydraulic (Ripper)	
A Tractor to rear of winch	1210 mm	47.7"	1210 mm	47.7"
B Tractor to drum centerline	945 mm	37.7"	945 mm	37.7"
C Ground to top of winch	1530 mm	60.2"	1580 mm	62.2"
D Ground to drum centerline	1160 mm	45.7"	1210 mm	47.7"
E Ground to center of hitch	725 mm	28.5"	775 mm	30.5"
F Tractor to drawbar pin centerline	910 mm	35.8"	910 mm	35.8"
Winch width (not shown) ¹	975 mm	38.3"	975 mm	38.3"
Drum diameter (not shown)	255 mm	10.0"	255 mm	10.0"
Weight ²	1180 kg	2600 lb	1180 kg	2600 lb
Oil refill capacity	67 L	17.75 U.S. gal	67 L	17.75 U.S. gal
Wire rope diameter:				
Recommended	22 mm	0.88"	22 mm	0.88"
Optional	26 mm	1.0"	26 mm	1.0"
Maximum theoretical drum capacity: ³				
Recommended rope	85 m	281'	85 m	281'
Optional rope	66 m	218'	66 m	218'
Maximum recommended drum capacity: ⁴				
Recommended rope	55 m	180'	55 m	180'
Optional rope	50 m	163'	50 m	163'
Wire rope ferrule size (OD)	54 mm	2.13"	54 mm	2.13"
Wire rope ferrule size (length)	67 mm	2.63"	67 mm	2.63"

¹Width does not include mounting brackets/adapters (if any).

²Weight shown is base winch only. Does not include mounting arrangement, control arrangement, oil, or wire rope.

³Per SAE J1158.

⁴Per SAE J706 (K=9).

⁵Meets Tier 4 Final/Stage IV/Japan 2014 (Tier 4 Final) emission standards.

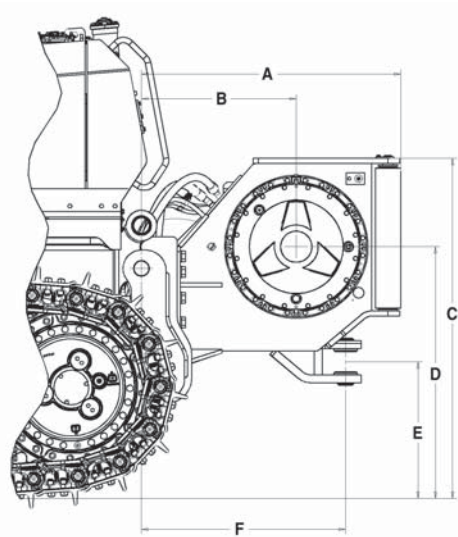

WINCH MODEL	PA90		H110B	
TRACTOR MODEL	D7E		D7E	
Tractor transmission	Electric		Electric	
Winch drive	Hydraulic		Hydraulic	
A Tractor to rear of winch	1265 mm	49.8"	1265 mm	4'8.5"
B Tractor to drum centerline	755 mm	29.7"	755 mm	3'0.4"
C Ground to top of winch	1665 mm	65.6"	1665 mm	5'6.8"
D Ground to drum centerline	1235 mm	48.5"	1235 mm	4'1.5"
E Ground to center of hitch	670 mm	26.3"	670 mm	2'3.8"
F Tractor to drawbar pin centerline	995 mm	39.2"	995 mm	4'0"
Winch width (not shown) ¹	1090 mm	43.0"	1160 mm	3'9.6"
Drum diameter (not shown)	320 mm	12.5"	320 mm	1'0.5"
Weight ²	1520 kg	3350 lb	1790 kg	3950 lb
Oil refill capacity	12 L	12.5 qt	15 L	4 U.S. gal
Wire rope diameter:				
Recommended	26 mm	1"	28 mm	1.13"
Optional	28 mm	1.13"	32 mm	1.25"
Maximum theoretical drum capacity: ³				
Recommended rope	68 m	223'	78 m	257'
Optional rope	54 m	178'	62 m	204'
Maximum recommended drum capacity: ⁴				
Recommended rope	56 m	183'	55 m	182'
Optional rope	38 m	126'	36 m	118'
Wire rope ferrule size (OD)	60 mm	2.38"	60 mm	2.38"
Wire rope ferrule size (length)	70 mm	2.75"	70 mm	2.75"

¹Width does not include mounting brackets/adapters (if any).

²Weight shown is base winch only. Does not include mounting arrangement, control arrangement, oil, or wire rope.

³Per SAE J1158.

⁴Per SAE J706 (K=9).

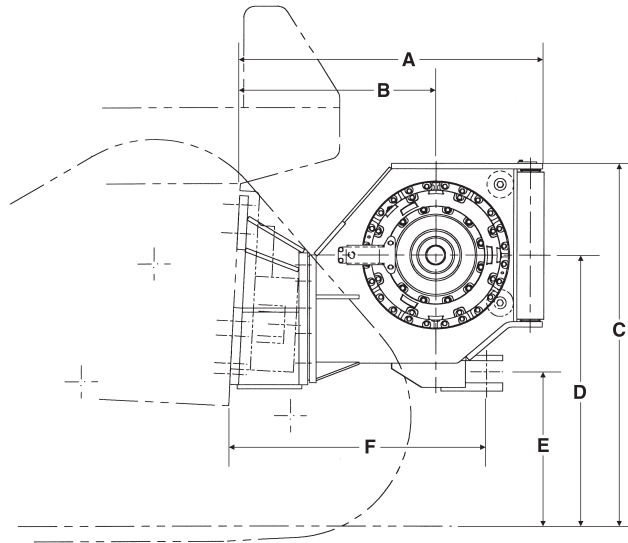

WINCH MODEL	PA90				H110B	
	D6R, D6T ⁵ XW VPAT		D6T ⁵ LGP and LGP VPAT		D6T	
Tractor transmission	Powershift		Powershift		Powershift	
Winch drive	Hydraulic (High Power)		Hydraulic (High Power)		Hydraulic (High Power)	
A Tractor to rear of winch	1380 mm	4'6"	1380 mm	4'6"	1380 mm	4'6"
B Tractor to drum centerline	870 mm	2'10"	870 mm	2'10"	870 mm	2'10"
C Ground to top of winch	1680 mm	5'6"	1730 mm	5'8"	1730 mm	5'8"
D Ground to drum centerline	1235 mm	4'1"	1285 mm	4'3"	1285 mm	4'3"
E Ground to center of hitch	670 mm	2'2"	720 mm	2'4"	720 mm	2'4"
F Tractor to drawbar pin centerline	1160 mm	3'8"	1160 mm	3'8"	1160 mm	3'8"
Winch width (not shown) ¹	1190 mm	3'7"	1190 mm	3'7"	1190 mm	3'7"
Drum diameter (not shown)	320 mm	1'1"	320 mm	1'1"	320 mm	1'1"
Weight ²	1500 kg	3300 lb	1500 kg	3300 lb	1790 kg	3950 lb
Oil refill capacity	12 L	3.13 U.S. gal	12 L	3.13 U.S. gal	15 L	4 U.S. gal
Wire rope diameter:						
Recommended	26 mm	1"	26 mm	1"	28 mm	1.13"
Optional	28 mm	1.13"	28 mm	1.13"	32 mm	1.25"
Maximum theoretical drum capacity: ³						
Recommended rope	69 m	226'	69 m	226'	78 m	257'
Optional rope	55 m	180'	55 m	180'	62 m	204'
Maximum recommended drum capacity: ⁴						
Recommended rope	57 m	186'	57 m	186'	55 m	182'
Optional rope	39 m	128'	39 m	128'	36 m	118'
Wire rope ferrule size (OD)	60 mm	2.38"	60 mm	2.38"	60 mm	2.38"
Wire rope ferrule size (length)	70 mm	2.75"	70 mm	2.75"	70 mm	2.75"

¹Width does not include mounting brackets/adapters (if any).

²Weight shown is base winch only. Does not include mounting arrangement, control arrangement, oil, or wire rope.

³Per SAE J1158.

⁴Per SAE J706 (K=.9).

⁵Meets Tier 3/Stage IIIA/Japan 2006 (Tier 3) equivalent emission standards.

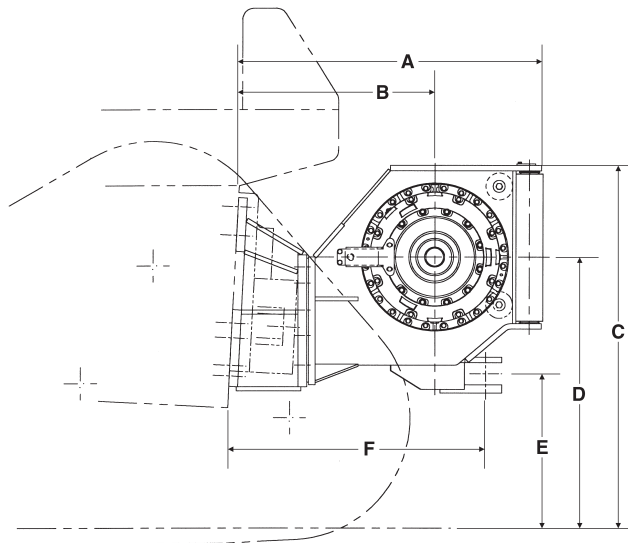

WINCH MODEL	H110B		PA110B	
TRACTOR MODEL	D7R		D7R	
Tractor transmission	Powershift		Powershift	
Winch drive	Hydraulic (Ripper)		Hydraulic (High Power)	
A Tractor to rear of winch	1585 mm	5'2.4"	1435 mm	4'8.5"
B Tractor to drum centerline	1075 mm	3'6.3"	925 mm	3'0.4"
C Ground to top of winch	1695 mm	5'6.8"	1695 mm	5'6.8"
D Ground to drum centerline	1255 mm	4'1.5"	1255 mm	4'1.5"
E Ground to center of hitch	705 mm	2'3.8"	705 mm	2'3.8"
F Tractor to drawbar pin centerline	1370 mm	4'5.9"	1220 mm	4'0"
Winch width (not shown) ¹	1160 mm	3'9.6"	1160 mm	3'9.6"
Drum diameter (not shown)	320 mm	1'0.5"	320 mm	1'0.5"
Weight ²	1790 kg	3950 lb	1790 kg	3950 lb
Oil refill capacity	15 L	4 U.S. gal	15 L	4 U.S. gal
Wire rope diameter:				
Recommended	28 mm	1.13"	28 mm	1.13"
Optional	32 mm	1.25"	32 mm	1.25"
Maximum theoretical drum capacity: ³				
Recommended rope	78 m	257'	78 m	257'
Optional rope	62 m	204'	62 m	204'
Maximum recommended drum capacity: ⁴				
Recommended rope	55 m	182'	55 m	182'
Optional rope	36 m	118'	36 m	118'
Wire rope ferrule size (OD)	60 mm	2.38"	60 mm	2.38"
Wire rope ferrule size (length)	70 mm	2.75"	70 mm	2.75"

¹Width does not include mounting brackets/adapters (if any).

²Weight shown is base winch only. Does not include mounting arrangement, control arrangement, oil, or wire rope.

³Per SAE J1158.

⁴Per SAE J706 (K=9).

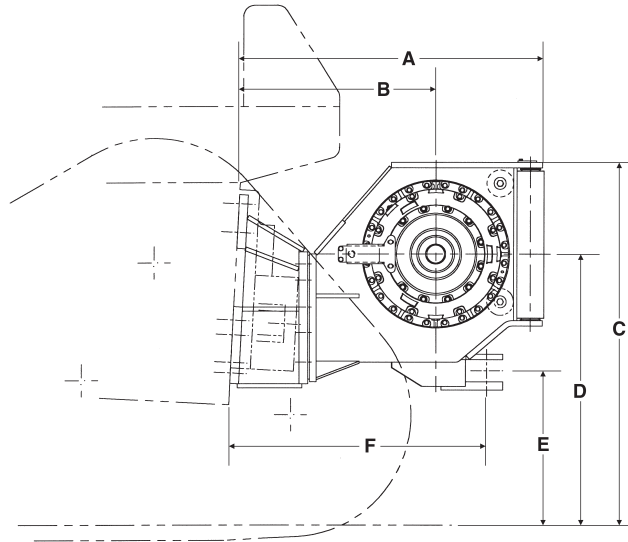

WINCH MODEL	H140				PA140			
	D8R, D8T		D9R, D9T		D8R, D8T		D9R, D9T	
TRACTOR MODEL	Powershift Hydraulic (Ripper)		Powershift Hydraulic (Ripper)		Powershift Hydraulic (High Power)		Powershift Hydraulic (High Power)	
Tractor transmission	Powershift		Powershift		Powershift		Powershift	
Winch drive	Hydraulic (Ripper)		Hydraulic (Ripper)		Hydraulic (High Power)		Hydraulic (High Power)	
A Tractor to rear of winch	1585 mm	5'2.4"	1525 mm	5'0.3"	1435 mm	4'8.5"	1620 mm	5'3.8"
B Tractor to drum centerline	1075 mm	3'6.3"	1015 mm	3'4.0"	925 mm	3'0.4"	1110 mm	3'7.7"
C Ground to top of winch	1715 mm	5'7.5"	1740 mm	5'8.4"	1715 mm	5'7.5"	1740 mm	5'8.4"
D Ground to drum centerline	1275 mm	4'2.1"	1300 mm	4'3.2"	1275 mm	4'2.1"	1300 mm	4'3.2"
E Ground to center of hitch	725 mm	2'4.5"	750 mm	2'5.5"	725 mm	2'4.5"	750 mm	2'5.5"
F Tractor to drawbar pin centerline	1370 mm	4'5.9"	1255 mm	4'1.5"	1220 mm	4'0"	1350 mm	4'5.2"
Winch width (not shown) ¹	1160 mm	3'9.6"	1160 mm	3'9.6"	1160 mm	3'9.6"	1160 mm	3'9.6"
Drum diameter (not shown)	320 mm	2'0.5"	320 mm	12.5"	320 mm	12.5"	320 mm	12.5"
Weight ²	1790 kg	3950 lb	1790 kg	3950 lb	1790 kg	3950 lb	1790 kg ⁵	3950 lb ⁵
Oil refill capacity	15 L	4 U.S. gal	15 L	4 U.S. gal	15 L	4 U.S. gal	15 L	4 U.S. gal
Wire rope diameter:								
Recommended	28 mm	1.13"	28 mm	1.13"	28 mm	1.13"	28 mm	1.13"
Optional	32 mm	1.25"	32 mm	1.25"	32 mm	1.25"	32 mm	1.25"
Maximum theoretical drum capacity: ³								
Recommended rope	78 m	257'	78 m	257'	78 m	257'	78 m	257'
Optional rope	62 m	204'	62 m	204'	62 m	204'	62 m	204'
Maximum recommended drum capacity: ⁴								
Recommended rope	55 m	182'	55 m	182'	55 m	182'	55 m	182'
Optional rope	36 m	118'	36 m	118'	36 m	118'	36 m	118'
Wire rope ferrule size (OD)	60 mm	2.38"	60 mm	2.38"	60 mm	2.38"	60 mm	2.38"
Wire rope ferrule size (length)	70 mm	2.75"	70 mm	2.75"	70 mm	2.75"	70 mm	2.75"

¹Width does not include mounting brackets/adapters (if any).

²Weight shown is base winch only. Does not include mounting arrangement, control arrangement, oil, or wire rope.

³Per SAE J1158.

⁴Per SAE J706 (K=,9).

⁵3700 kg (8150 lb) with counterweight.

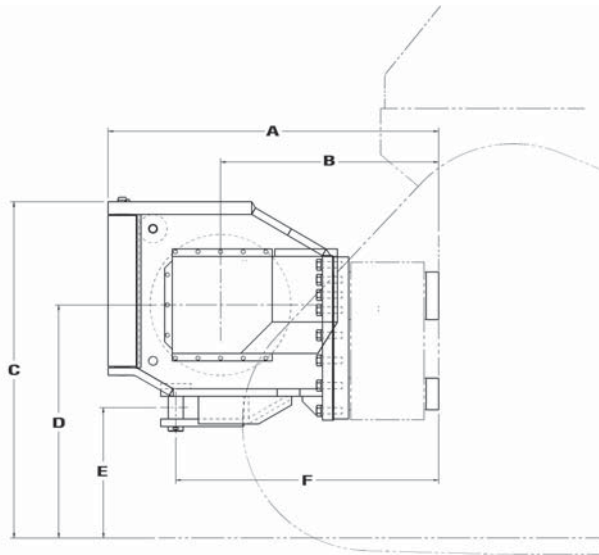

WINCH MODEL	H200			
TRACTOR MODEL	D8T		D9T	
Tractor transmission	Powershift		Powershift	
Winch drive	Hydraulic (High Power)		Hydraulic (High Power)	
A Tractor to rear of winch	1460 mm	57.5"	1645 mm	64.8"
B Tractor to drum centerline	960 mm	37.7"	1075 mm	42.4"
C Ground to top of winch	1760 mm	69.4"	1735 mm	68.3"
D Ground to drum centerline	1240 mm	48.8"	1215 mm	47.9"
E Ground to center of hitch	725 mm	28.5"	700 mm	27.5"
F Tractor to drawbar pin centerline	1170 mm	46.1"	1305 mm	51.3"
Winch width (not shown) ¹	1400 mm	55"	1400 mm	55"
Drum diameter (not shown)	380 mm	15"	380 mm	15"
Weight ²	3180 kg	7015 lb	3180 kg ⁵	7015 lb ⁵
Oil refill capacity	16.5 L	4.4 U.S. gal	16.5 L	4.4 U.S. gal
Wire rope diameter:				
Recommended	35 mm	1.38"	35 mm	1.38"
Optional	38 mm	1.5"	38 mm	1.5"
Maximum theoretical drum capacity: ³				
Recommended rope	81 m	266'	81 m	266'
Optional rope	68 m	224'	68 m	224'
Maximum recommended drum capacity: ⁴				
Recommended rope	64 m	211'	64 m	211'
Optional rope	42 m	138'	42 m	138'
Wire rope ferrule size (OD)	71 mm	2.81"	71 mm	2.81"
Wire rope ferrule size (length)	79 mm	3.12"	79 mm	3.12"

¹Width does not include mounting brackets/adapters (if any).

²Weight shown is base winch only. Does not include mounting arrangement, control arrangement, oil, or wire rope.

³Per SAE J1158.

⁴Per SAE J706 (K=,9).

⁵5080 kg (11,200 lb) with counterweight.

WINCH MODEL		PA40	PA50	H60	H85
TRACTOR MODEL		D3K2, D4K2, D5K2 ⁽⁵⁾	D6K2	D5R, D6N	D6T ⁽⁶⁾
Tractor transmission.		Hydrostatic	Hydrostatic	Powershift	Powershift
Winch drive		Hydrostatic	Hydrostatic	Hydraulic (Ripper)	Hydraulic (Ripper)
British Units of Measure					
Bare Drum	Maximum line pull ⁽¹⁾ lb	40,000	50,000	60,000	85,000
	Rated line speed ⁽²⁾ fpm	49	45	33	31
	Maximum line speed ⁽³⁾ fpm	132	124	99	64
Full Drum ⁽⁴⁾	Maximum line pull ⁽¹⁾ lb	25,000	26,000	35,000	52,800
	Rated line speed ⁽²⁾ fpm	78	83	56	50
	Maximum line speed ⁽³⁾ fpm	207	230	170	93
Metric Units of Measure					
Bare Drum	Maximum line pull ⁽¹⁾ kN	177.9	222.4	266.9	378.5
	Rated line speed ⁽²⁾ m/min	15	14	10	9
	Maximum line speed ⁽³⁾ m/min	40	38	30	20
Full Drum ⁽⁴⁾	Maximum line pull ⁽¹⁾ kN	111.2	115.7	155.7	259.9
	Rated line speed ⁽²⁾ m/min	24	25	17	15
	Maximum line speed ⁽³⁾ m/min	63	70	52	28

⁽¹⁾“Maximum line pull” is lesser of winch catalog rating or calculated maximum line pull at maximum tractor hydraulic system pressure.

⁽²⁾“Rated line speed” is calculated maximum line speed at maximum line pull.

⁽³⁾“Maximum line speed” is calculated maximum no-load line speed at maximum tractor hydraulic system flow.

⁽⁴⁾“Full Drum” as defined by SAE J1158.

⁽⁵⁾Meets Tier 3/Stage IIIA/Japan 2006 (Tier 3) equivalent emission standards.

⁽⁶⁾Meets Tier 4 Final/Stage IV/Japan 2014 (Tier 4 Final) emission standards.

WINCH MODEL		H110B	PA90		
TRACTOR MODEL		D6T ⁽⁵⁾	D6R	D6T	D7E
Tractor transmission.		Powershift	Powershift	Powershift	Electric
Winch drive		Hydraulic (Ripper)	Hydraulic (High Power)	Hydraulic (High Power)	Hydraulic (High Power)
British Units of Measure					
Bare Drum	Maximum line pull ⁽¹⁾ lb	110,000	90,000	90,000	90,000
	Rated line speed ⁽²⁾ fpm	20	54	35	32
	Maximum line speed ⁽³⁾ fpm	38	87	68	71
Full Drum ⁽⁴⁾	Maximum line pull ⁽¹⁾ lb	66,200	53,600	53,600	53,600
	Rated line speed ⁽²⁾ fpm	33	85	59	53
	Maximum line speed ⁽³⁾ fpm	63	139	114	120
Metric Units of Measure					
Bare Drum	Maximum line pull ⁽¹⁾ kN	490.3	400.3	400.3	400.3
	Rated line speed ⁽²⁾ m/min	6	16	10	10
	Maximum line speed ⁽³⁾ m/min	12	26	20	22
Full Drum ⁽⁴⁾	Maximum line pull ⁽¹⁾ kN	295.2	238.4	238.4	238.4
	Rated line speed ⁽²⁾ m/min	10	26	18	16
	Maximum line speed ⁽³⁾ m/min	19	42	34	37

⁽¹⁾“Maximum line pull” is lesser of winch catalog rating or calculated maximum line pull at maximum tractor hydraulic system pressure.

⁽²⁾“Rated line speed” is calculated maximum line speed at maximum line pull.

⁽³⁾“Maximum line speed” is calculated maximum no-load line speed at maximum tractor hydraulic system flow.

⁽⁴⁾“Full Drum” as defined by SAE J1158.

⁽⁵⁾Meets Tier 4 Interim/Stage IIIB/Japan 2011 (Tier 4 Interim) equivalent emission standards.

WINCH MODEL		H110B	H110B	PA110B
TRACTOR MODEL		D7E	D7R	D7R
Tractor transmission.		Electric	Powershift	Powershift
Winch drive.		Hydraulic (Ripper)	Hydraulic (Ripper)	Hydraulic (High Power)
British Units of Measure				
Bare Drum	Maximum line pull ⁽¹⁾ lb	110,000	101,000	110,000
	Rated line speed ⁽²⁾ fpm	23	24	33
	Maximum line speed ⁽³⁾ fpm	55	51	100
Full Drum ⁽⁴⁾	Maximum line pull ⁽¹⁾ lb	66,200	61,000	66,500
	Rated line speed ⁽²⁾ fpm	38	39	54
	Maximum line speed ⁽³⁾ fpm	90	84	165
Metric Units of Measure				
Bare Drum	Maximum line pull ⁽¹⁾ kN	490.3	449.3	489.3
	Rated line speed ⁽²⁾ m/min	7	7	10
	Maximum line speed ⁽³⁾ m/min	17	15	30
Full Drum ⁽⁴⁾	Maximum line pull ⁽¹⁾ kN	295.2	271.3	295.8
	Rated line speed ⁽²⁾ m/min	12	12	16
	Maximum line speed ⁽³⁾ m/min	27	25	50

⁽¹⁾“Maximum line pull” is lesser of winch catalog rating or calculated maximum line pull at maximum tractor hydraulic system pressure.

⁽²⁾“Rated line speed” is calculated maximum line speed at maximum line pull.

⁽³⁾“Maximum line speed” is calculated maximum no-load line speed at maximum tractor hydraulic system flow.

⁽⁴⁾“Full Drum” as defined by SAE J1158.

WINCH MODEL		H140		PA140	
TRACTOR MODEL		D8R, D8T	D9R, D9T	D8T	D9T
Tractor transmission.		Powershift	Powershift	Powershift	Powershift
Winch drive.		Hydraulic (Ripper)	Hydraulic (Ripper)	Hydraulic (High Power)	Hydraulic (High Power)
British Units of Measure					
Bare Drum	Maximum line pull ⁽¹⁾ lb	140,000	140,000	140,000	140,000
	Rated line speed ⁽²⁾ fpm	19	17	23	23
	Maximum line speed ⁽³⁾ fpm	38	35	46	46
Full Drum ⁽⁴⁾	Maximum line pull ⁽¹⁾ lb	84,600	84,600	84,600	84,600
	Rated line speed ⁽²⁾ fpm	31	28	38	38
	Maximum line speed ⁽³⁾ fpm	63	58	76	76
Metric Units of Measure					
Bare Drum	Maximum line pull ⁽¹⁾ kN	622.8	622.8	622.8	622.8
	Rated line speed ⁽²⁾ m/min	6	5	7	7
	Maximum line speed ⁽³⁾ m/min	11	10	14	14
Full Drum ⁽⁴⁾	Maximum line pull ⁽¹⁾ kN	376.3	376.3	376.3	376.3
	Rated line speed ⁽²⁾ m/min	9	8	11	11
	Maximum line speed ⁽³⁾ m/min	19	17	23	23

⁽¹⁾“Maximum line pull” is lesser of winch catalog rating or calculated maximum line pull at maximum tractor hydraulic system pressure.

⁽²⁾“Rated line speed” is calculated maximum line speed at maximum line pull.

⁽³⁾“Maximum line speed” is calculated maximum no-load line speed at maximum tractor hydraulic system flow.

⁽⁴⁾“Full Drum” as defined by SAE J1158.

WINCH MODEL		PA55	PA56
TRACTOR MODEL		D5R, D6N	D6R, D6T, D6T ⁽⁶⁾
Tractor transmission		Powershift	Powershift
Winch drive		PTO	PTO
British Units of Measure			
Bare Drum	Rated line pull ⁽¹⁾ lb	36,600	59,100
	Maximum line pull ⁽²⁾ lb	69,200	89,800
	Rated line speed ⁽³⁾ fpm	92	80
	Maximum line speed ⁽⁴⁾ fpm	141	130
Full Drum ⁽⁵⁾	Rated line pull ⁽¹⁾ lb	20,900	34,400
	Maximum line pull ⁽²⁾ lb	54,100	76,300
	Rated line speed ⁽³⁾ fpm	158	136
	Maximum line speed ⁽⁴⁾ fpm	218	224
Slow speed gearing			
Bare Drum	Rated line pull ⁽¹⁾ lb	50,000	70,000
	Maximum line pull ⁽²⁾ lb	69,200	89,800
	Rated line speed ⁽³⁾ fpm	38	35
	Maximum line speed ⁽⁴⁾ fpm	53	58
Full Drum ⁽⁵⁾	Rated line pull ⁽¹⁾ lb	50,000	70,000
	Maximum line pull ⁽²⁾ lb	69,200	89,800
	Rated line speed ⁽³⁾ fpm	66	63
	Maximum line speed ⁽⁴⁾ fpm	91	103
Metric Units of Measure			
Bare Drum	Rated line pull ⁽¹⁾ kN	162.8	262.9
	Maximum line pull ⁽²⁾ kN	307.8	399.5
	Rated line speed ⁽³⁾ m/min	28	24
	Maximum line speed ⁽⁴⁾ m/min	43	40
Full Drum ⁽⁵⁾	Rated line pull ⁽¹⁾ kN	93.0	153.0
	Maximum line pull ⁽²⁾ kN	240.6	153.9
	Rated line speed ⁽³⁾ m/min	48	41
	Maximum line speed ⁽⁴⁾ m/min	66	68
Slow speed gearing			
Bare Drum	Rated line pull ⁽¹⁾ kN	222.4	311.4
	Maximum line pull ⁽²⁾ kN	307.8	399.5
	Rated line speed ⁽³⁾ m/min	12	11
	Maximum line speed ⁽⁴⁾ m/min	16	18
Full Drum ⁽⁵⁾	Rated line pull ⁽¹⁾ kN	222.4	311.4
	Maximum line pull ⁽²⁾ kN	307.8	399.5
	Rated line speed ⁽³⁾ m/min	20	19
	Maximum line speed ⁽⁴⁾ m/min	28	31

⁽¹⁾ "Rated line pull" is lesser of winch catalog rating or calculated line pull at maximum tractor PTO output power.

⁽²⁾ "Maximum line pull" is lesser of calculated line pull at maximum tractor PTO output torque or catalog breaking strength of maximum optional size new IWRC IPS wire rope.

⁽³⁾ "Rated line speed" is calculated line speed at maximum tractor PTO output power.

⁽⁴⁾ "Maximum line speed" is calculated no-load line speed at maximum tractor engine PTO output speed.

⁽⁵⁾ "Full Drum" as defined by SAE J1158.

⁽⁶⁾ Meets Tier 4 Final/Stage IV/Japan 2014 (Tier 4 Final) emission standards.

WINCH MODEL		H200	
TRACTOR MODEL		D8T	D9T
Tractor transmission.		Powershift	Powershift
Winch drive.		Hydraulic (High Power)	Hydraulic (High Power)
British Units of Measure			
Bare Drum	Maximum line pull ⁽¹⁾ lb	180,000	200,000
	Rated line speed ⁽²⁾ fpm	17	17
	Maximum line speed ⁽³⁾ fpm	38	38
Full Drum ⁽⁴⁾	Maximum line pull ⁽¹⁾ lb	112,000	124,500
	Rated line speed ⁽²⁾ fpm	27	27
	Maximum line speed ⁽³⁾ fpm	61	61
Metric Units of Measure			
Bare Drum	Maximum line pull ⁽¹⁾ kN	800.7	889.6
	Rated line speed ⁽²⁾ m/min	5	5
	Maximum line speed ⁽³⁾ m/min	11	11
Full Drum ⁽⁴⁾	Maximum line pull ⁽¹⁾ kN	498.2	553.8
	Rated line speed ⁽²⁾ m/min	8	8
	Maximum line speed ⁽³⁾ m/min	18	18

⁽¹⁾“Maximum line pull” is lesser of winch catalog rating or calculated maximum line pull at maximum hydraulic system pressure.
⁽²⁾“Rated line speed” is calculated maximum line speed at maximum hydraulic system pressure and flow with winch motor at maximum displacement.
⁽³⁾“Maximum line speed” is calculated maximum no-load line speed at maximum hydraulic system flow with winch motor at minimum displacement.
⁽⁴⁾“Full Drum” as defined by SAE J1158.

Allied Features:

- **Proven performance on Caterpillar.** Allied winches trace their roots to Hyster winches on Cat tractors since 1929. Allied acquired Hyster winches in 1990, maintaining the same engineering excellence. Existing dealer parts inventory continues to be interchangeable to support the thousands of Allied/Hyster winches in the field.
- **“Plug and Play” design.** Winches come complete with all the necessary parts for simple and easy field installation on any tractor. They do not require Winch Ready packages pre-ordered on the tractors. This simplifies dealer inventory planning.
- **Self-Contained Hydraulics (SCH) design.** All hoses, pump and valve are inside the PTO winch frame, totally eliminating external leakage.

Standard Equipment

- Freespool function for W3C, H4A, W5C, H5C, W6F, W6G and H6H winches. Adjustable freespool drag to allow cable to be pulled out easily by hand.
- Heavy duty box-section winch frame withstands demanding side pulls without the need for fairlead.
- Brake off function for most winches. Keeps cable tight while the tractor drives away to prevent cable bird nesting.
- Multiple-disc oil clutches and brake on PTO winches are oil-cooled for long life.
- Drawbar for most winches. Provides an additional hitch for load towing.
- Power line-in and power line-out.

Optional Equipment

- Fairlead to handle frequent side pulls from all angles. Hardened vertical and horizontal rollers reduce cable wear.
- Arch works like a raised fairlead to lift loads off ground for efficient skidding.
- Choice of standard gear ratio for fast operation in logging, or slow speed gear ratio for fine speed control in pipelaying and power line sagging applications.
- Electronic control for precise speed control.

Two families of winches – Power Take-Off (PTO) driven or Hydraulically driven winches covering D3 through D10 tractors, pipelayers and track loaders, the most comprehensive winch in the industry.

- **PTO** winches able to utilize full range of engine power. Brute force and fast line speeds.
- **Hydraulic** winches provide fingertip precision control over line speed. Motor only turns on demand equaling less wear and maintenance.

Winch Selection Guide:

Tractor Class*	PTO Winch	Hydraulic Winch
D3-5K	—	H4A
D6K	—	H5C
527 TSK	W6F	—
D6N, D5R	W5C, W6G, W6F	H5C, H6H
D6T, D6R	W6G, W6F	H6H
D7R	W8L	H8L
D7E	—	H8L
D8-9-10R, D8-9-10T	W12E	H12E

*For non-current tractors contact Allied Systems Company for winch options.

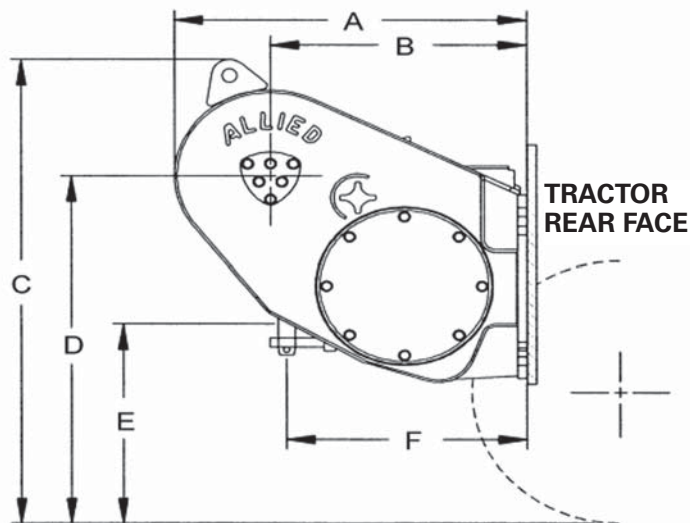

WINCH MODEL	H4AT		H4AH Hi-P	
TRACTOR MODEL	D3K2, D4K2, D5K2*		D3K2, D4K2, D5K2*	
Winch drive	Ripper Hydraulics		Allied Hi-Flow Pump	
Winch type	Standard		Hi-Performance	
A Tractor to rear of winch	813 mm	32"	813 mm	32"
B Tractor to drum centerline	610 mm	24"	610 mm	24"
C Ground to top of winch	1143 mm	45"	1143 mm	45"
D Ground to drum centerline	889 mm	35"	889 mm	35"
E Ground to center of hitch	508 mm	20"	508 mm	20"
F Tractor to pin centerline	584 mm	23"	584 mm	23"
Overall width (not shown)	737 mm	29"	737 mm	29"
Drum diameter (not shown)	203 mm	8"	203 mm	8"
Weight	771 kg	1700 lb	812 kg	1790 lb
Oil refill capacity	19 L	5 U.S. gal	19 L	5 U.S. gal
Wire rope diameter:				
Recommended	16 mm	0.63"	16 mm	0.63"
Optional	19 mm	0.75"	19 mm	0.75"
Drum capacity:				
Recommended rope	84 m	277'	84 m	277'
Optional rope	59 m	195'	59 m	195'
Wire rope ferrule size (OD)	38 mm	1.5"	38 mm	1.5"
Wire rope ferrule size (length)	51 mm	2"	51 mm	2"

*Specifications based on representative models marked *. Others similar.

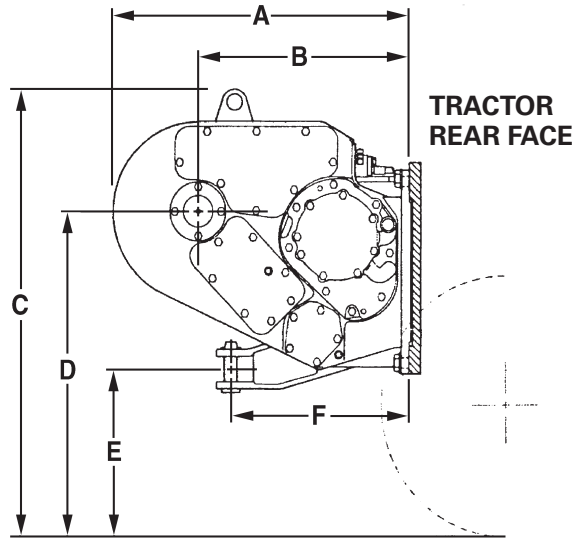

WINCH MODEL	H5CT		H5CH Hi-P	
TRACTOR MODEL	D6K2		D6K2	
Winch drive	Ripper Hydraulics		Allied Hi-Flow Pump	
Winch type	Standard		Hi-Performance	
A Tractor to rear of winch	864 mm	34"	864 mm	34"
B Tractor to drum centerline	635 mm	25"	635 mm	25"
C Ground to top of winch	1118 mm	44"	1118 mm	44"
D Ground to drum centerline	787 mm	31"	787 mm	31"
E Ground to center of hitch	381 mm	15"	381 mm	15"
F Tractor to pin centerline	559 mm	22"	559 mm	22"
Overall width (not shown)	813 mm	32"	813 mm	32"
Drum diameter (not shown)	229 mm	9"	229 mm	9"
Weight	898 kg	1980 lb	930 kg	2050 lb
Oil refill capacity	12.5 L	3.3 U.S. gal	12.5 L	3.3 U.S. gal
Wire rope diameter:				
Recommended	19 mm	0.75"	19 mm	0.75"
Optional	22 mm	0.88"	22 mm	0.88"
Drum capacity:				
Recommended rope	91 m	298'	91 m	298'
Optional rope	66 m	215'	66 m	215'
Wire rope ferrule size (OD)	51 mm	2"	51 mm	2"
Wire rope ferrule size (length)	57 mm	2.25"	57 mm	2.25"

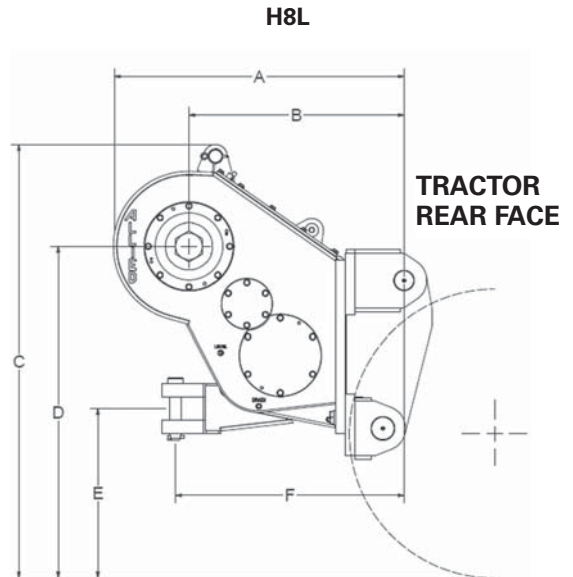
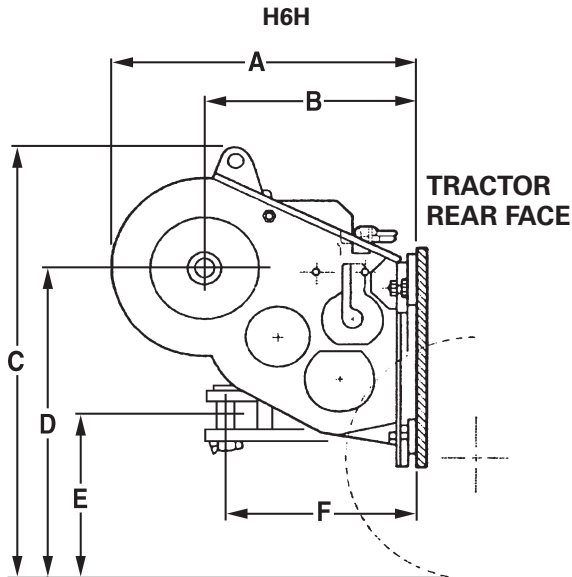

WINCH MODEL	H6H		H8L	
TRACTOR MODEL	D6N, D6R, D6R XL, D6T*		D7E*, D7R	
Winch drive	Ripper Hydraulics		Hydraulic	
Winch type	Standard		Standard	
A Tractor to rear of winch	1219 mm	48"	1143 mm	45"
B Tractor to drum centerline	940 mm	37"	813 mm	32"
C Ground to top of winch	1549 mm	61"	1651 mm	65"
D Ground to drum centerline	1194 mm	47"	1270 mm	50"
E Ground to center of hitch	711 mm	28"	660 mm	26"
F Tractor to pin centerline	940 mm	37"	864 mm	34"
Overall width (not shown)	1041 mm	41"	1067 mm	42"
Drum diameter (not shown)	254 mm	10"	305 mm	12"
Weight	1284 kg	2830 lb	1542 kg	3400 lb
Oil refill capacity	8 L	2.1 U.S. gal	15 L	4 U.S. gal
Wire rope diameter:				
Recommended	22 mm	0.88"	25 mm	1"
Optional	25 mm	1"	29 mm	1.12"
Drum capacity:				
Recommended rope	91 m	297'	102 m	334'
Optional rope	70 m	230'	81 m	267'
Wire rope ferrule size (OD)	51 mm	2"	57 mm	2.25"
Wire rope ferrule size (length)	57 mm	2.25"	60 mm	2.38"

*Specifications based on representative models marked *. Others similar.

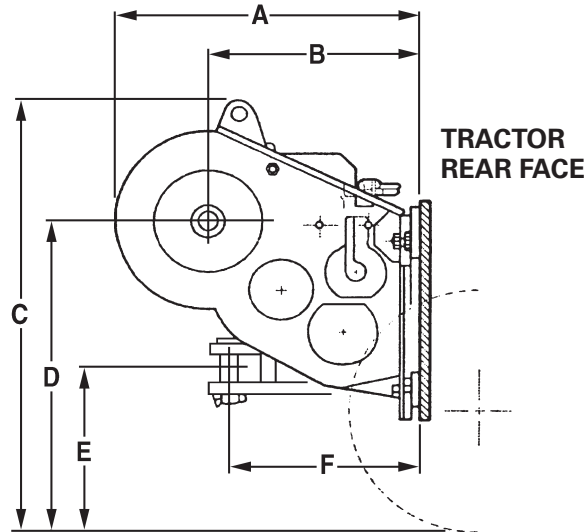

WINCH MODEL	H12E		
TRACTOR MODEL	D8T*, D9T, D10T2		
Winch drive	Hydraulic		
Winch type	Standard		
A Tractor to rear of winch	1499 mm		59"
B Tractor to drum centerline	1168 mm		46"
C Ground to top of winch	1778 mm		70"
D Ground to drum centerline	1372 mm		54"
E Ground to center of hitch	711 mm		28"
F Tractor to pin centerline	1295 mm		51"
Overall width (not shown)	1245 mm		49"
Drum diameter (not shown)	356 mm		14"
Weight	2087 kg		4600 lb
Oil refill capacity	26.5 L		7 U.S. gal
Wire rope diameter:			
Recommended	29 mm		1.13"
Optional	32 mm		1.25"
Drum capacity:			
Recommended rope	70 m		229'
Optional rope	55 m		182'
Wire rope ferrule size (OD)	57 mm		2.25"
Wire rope ferrule size (length)	60 mm		2.38"

*Specifications based on representative models marked *. Others similar.

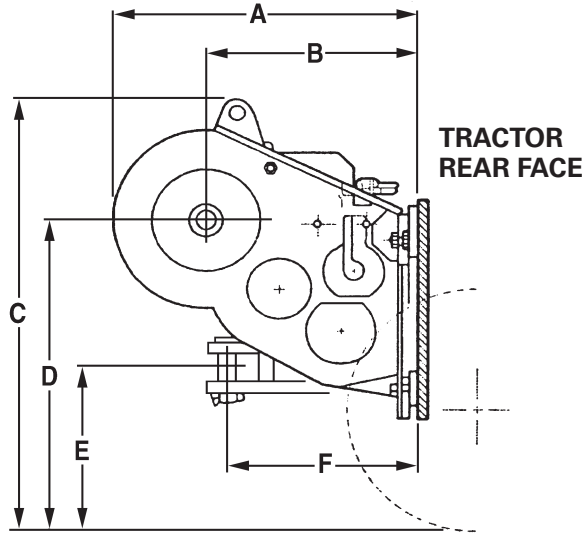

WINCH MODEL	W6G*		W6F*			
	D5R2		527		D6R2	
TRACTOR MODEL	PTO		PTO		PTO	
	Standard		Standard		Standard	
Winch drive						
Winch type						
A Tractor to rear of winch	1041 mm	3'5"	1041 mm	3'5"	1244 mm	4'1"
B Tractor to drum centerline	737 mm	2'5"	762 mm	2'6"	965 mm	3'2"
C Ground to top of winch	1549 mm	5'1"	1549 mm	5'1"	1549 mm	5'1"
D Ground to drum centerline	1193 mm	3'11"	1193 mm	3'11"	1193 mm	3'11"
E Ground to center of hitch	711 mm	2'4"	711 mm	2'4"	711 mm	2'4"
F Tractor to pin centerline	737 mm	2'5"	737 mm	2'5"	737 mm	2'5"
Overall width (not shown)	1000 mm	3'4"	965 mm	3'2"	965 mm	3'2"
Drum diameter (not shown)	254 mm	10"	254 mm	10"	254 mm	10"
Weight	1360 kg	3000 lb	1360 kg	3000 lb	1360 kg	3000 lb
Oil refill capacity	62.5 L	16.5 U.S. gal	72 L	19 U.S. gal	72 L	19 U.S. gal
Wire rope diameter:						
Recommended	22 mm	0.88"	22 mm	0.88"	22 mm	0.88"
Optional	25 mm	1"	25 mm	1"	25 mm	1"
Drum capacity:						
Recommended rope	82.6 m	271'	87 m	287'	87 m	287'
Optional rope	64 m	210'	68 m	223'	68 m	223'
Wire rope ferrule size (OD)	51 mm	2"	51 mm	2"	51 mm	2"
Wire rope ferrule size (length)	57 mm	2.25"	57 mm	2.25"	57 mm	2.25"

*W6F winch is configured for forestry applications, W6G for all other applications.

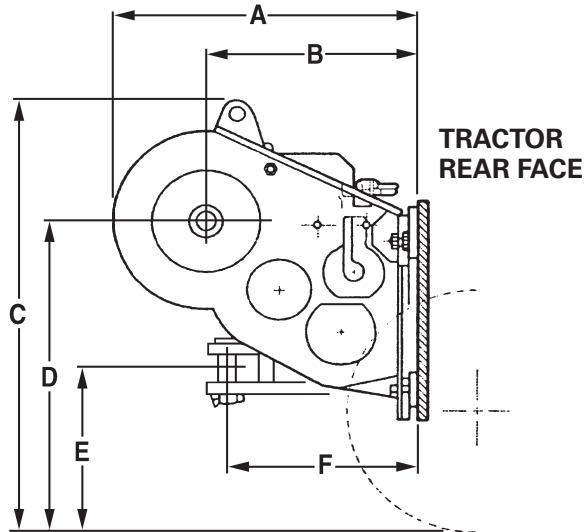

WINCH MODEL	W6G				W8L	
	D6R, D6RXL, D6T*		D6N		D7R	
Tractor Model	D6R, D6RXL, D6T*		D6N		D7R	
Winch drive	PTO		PTO		PTO	
Winch type	Standard		Standard		Standard	
A Tractor to rear of winch	1245 mm	49"	1245 mm	49"	1245 mm	49"
B Tractor to drum centerline	965 mm	38"	965 mm	38"	965 mm	38"
C Ground to top of winch	1549 mm	61"	1549 mm	61"	1600 mm	63"
D Ground to drum centerline	1194 mm	47"	1194 mm	47"	1219 mm	48"
E Ground to center of hitch	711 mm	28"	711 mm	28"	610 mm	24"
F Tractor to pin centerline	940 mm	37"	940 mm	37"	1067 mm	42"
Overall width (not shown)	965 mm	38"	965 mm	38"	1041 mm	41"
Drum diameter (not shown)	254 mm	10"	254 mm	10"	305 mm	12"
Weight	1542 kg	3400 lb	1542 kg	3400 lb	1724 kg	3800 lb
Oil refill capacity	72 L	19 U.S. gal	72 L	19 U.S. gal	72 L	19 U.S. gal
Wire rope diameter:						
Recommended	22 mm	0.88"	22 mm	0.88"	25 mm	1"
Optional	25 mm	1"	25 mm	1"	29 mm	1.13"
Drum capacity:						
Recommended rope	87 m	287'	87 m	287'	84 m	275'
Optional rope	58 m	189'	58 m	189'	54 m	176'
Wire rope ferrule size (OD)	51 mm	2"	51 mm	2"	57 mm	2.25"
Wire rope ferrule size (length)	57 mm	2.25"	57 mm	2.25"	60 mm	2.38"

*Specifications based on representative models marked *. Others similar.

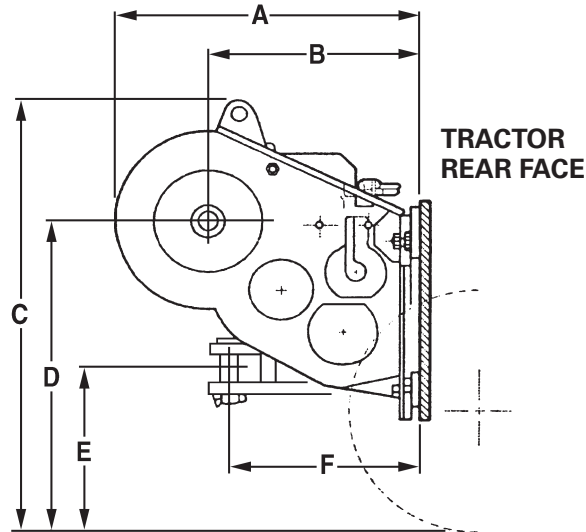

WINCH MODEL	W12E			
	D8T*, D9R, D9T, PL83, PL87		D10T2	
Tractor Model				
Winch drive	PTO		PTO	
Winch type	Standard		Standard	
A Tractor to rear of winch	1473 mm	58"	1346 mm	53"
B Tractor to drum centerline	1143 mm	45"	1041 mm	41"
C Ground to top of winch	1753 mm	69"	1753 mm	69"
D Ground to drum centerline	1346 mm	53"	1346 mm	53"
E Ground to center of hitch	686 mm	27"	686 mm	27"
F Tractor to pin centerline	1270 mm	50"	1168 mm	46"
Overall width (not shown)	1219 mm	48"	1219 mm	48"
Drum diameter (not shown)	356 mm	14"	356 mm	14"
Weight	2880 kg	6350 lb	4105 kg	9050 lb
Oil refill capacity	121 L	32 U.S. gal	121 L	32 U.S. gal
Wire rope diameter:				
Recommended	29 mm	1.125"	29 mm	1.125"
Optional	32 mm	1.25"	32 mm	1.25"
Drum capacity:				
Recommended rope	69 m	228'	69 m	228'
Optional rope	55 m	181'	55 m	181'
Wire rope ferrule size (OD)	57 mm	2.25"	57 mm	2.25"
Wire rope ferrule size (length)	60 mm	2.38"	60 mm	2.38"

*Specifications based on representative models marked *. Others similar.

WINCH MODEL		H4AT	H4AH
TRACTOR MODEL		D3K2, D4K2, D5K2*	D3K2, D4K2, D5K2*
Winch drive.....		Ripper Hydraulics	Allied Hi-Flow Pump
Winch type.....		Standard	Hi-Performance
British Units of Measure			
Bare Drum	Maximum line pull** lb	32,150	38,600
	Line speed at fpm	34	94
	Typical line pull of lb	20,000	20,000
	Maximum line speed fpm	46	100
Full Drum	Maximum line pull** lb	18,350	22,050
	Line speed at fpm	48	98
	Typical line pull of lb	17,400	20,000
	Maximum line speed fpm	81	176
Metric Units of Measure			
Bare Drum	Maximum line pull** kg	14 583	17 509
	Line speed at m/min	10.4	28.7
	Typical line pull of kg	9072	9072
	Maximum line speed m/min	14	31.5
Full Drum	Maximum line pull** kg	8323	10 002
	Line speed at m/min	14.6	29.9
	Typical line pull of kg	7893	9072
	Maximum line speed m/min	25	54

Performance based on standard gear ratio. Optional gear ratios available for different line speed and line pull requirements.

*Specifications based on representative models marked *. Others similar.

**Based on lower measurement of maximum line pull that the tractor can develop with the standard gear ratio, or the breaking strength of the maximum recommended wire.

WINCH MODEL		H5CT	H5CH
TRACTOR MODEL		D6K2	D6K2
Winch drive.....		Ripper Hydraulics	Allied Hi-Flow Pump
Winch type.....		Standard	Hi-Performance
British Units of Measure			
Bare Drum	Maximum line pull*	66,700	59,750
	Line speed at	25	97
	Typical line pull of	30,000	30,000
	Maximum line speed	52	128
Full Drum	Maximum line pull*	35,950	32,200
	Line speed at	47	70
	Typical line pull of	30,000	30,000
	Maximum line speed	97	237
Metric Units of Measure			
Bare Drum	Maximum line pull*	30 255	27 102
	Line speed at	7.6	29.6
	Typical line pull of	13 608	13 608
	Maximum line speed	16	39
Full Drum	Maximum line pull*	16 307	14 606
	Line speed at	14.3	21.3
	Typical line pull of	13 608	13 608
	Maximum line speed	30	72

Performance based on standard gear ratio. Optional gear ratios available for different line speed and line pull requirements.

*Based on lower measurement of maximum line pull that the tractor can develop with the standard gear ratio, or the breaking strength of the maximum recommended wire.

WINCH MODEL		H6H	H8L	H12E
TRACTOR MODEL		D6T*, D6R, D6N	D7E	D8T*, D9T, D10T2
Winch drive.....		Ripper Hydraulics	Hydraulic	Hydraulic
Winch type.....		Standard	Standard	Standard
British Units of Measure				
Bare Drum	Maximum line pull** lb	88,800	112,500	130,250
	Line speed at..... fpm	58	29	22
	Typical line pull of..... lb	40,000	50,000	80,000
	Maximum line speed fpm	69	65	76
Full Drum	Maximum line pull** lb	48,250	72,600	83,650
	Line speed at..... fpm	60	47	35
	Typical line pull of..... lb	40,000	50,000	80,000
	Maximum line speed fpm	129	106	119
Metric Units of Measure				
Bare Drum	Maximum line pull** kg	40 280	52 029	59 080
	Line speed at..... m/min	18.0	8.8	7.0
	Typical line pull of..... kg	18 144	22 700	36 287
	Maximum line speed m/min	21.0	19.8	23.2
Full Drum	Maximum line pull** kg	21 886	32 900	37 943
	Line speed at..... m/min	18.0	14.3	10.7
	Typical line pull of..... kg	18 144	22 700	36 287
	Maximum line speed m/min	39.0	32.3	36.3

Performance based on standard gear ratio. Optional gear ratios available for different line speed and line pull requirements.

*Specifications based on representative models marked *. Others similar.

**Based on lower measurement of maximum line pull that the tractor can develop with the standard gear ratio, or the breaking strength of the maximum recommended wire.

WINCH MODEL		W6F		W6G	
TRACTOR MODEL		527		D5R2	
Winch drive.....		PTO		PTO	
Winch type.....		Standard		Standard	
British Units of Measure					
Bare Drum	Maximum line pull** lb	88,800	88,800	88,800	88,800
	Line speed at..... fpm	93	59	93	93
	Typical line pull of..... lb	40,000	40,000	40,000	40,000
	Maximum line speed fpm	120	68	120	120
Full Drum	Maximum line pull** lb	71,200	88,800	71,200	71,200
	Line speed at..... fpm	99	90	99	99
	Typical line pull of..... lb	40,000	40,000	40,000	40,000
	Maximum line speed fpm	219	124	219	219
Metric Units of Measure					
Bare Drum	Maximum line pull** kg	40 280	40 280	40 280	40 280
	Line speed at..... m/min	28.3	18.0	28.3	28.3
	Typical line pull of..... kg	18 144	18 144	18 144	18 144
	Maximum line speed m/min	37	21	37	37
Full Drum	Maximum line pull** kg	32 296	40 280	32 296	32 296
	Line speed at..... m/min	30.2	27.4	30.2	30.2
	Typical line pull of..... kg	18 144	18 144	18 144	18 144
	Maximum line speed m/min	67	38	67	67

Performance based on standard gear ratio. Optional gear ratios available for different line speed and line pull requirements.

*Specifications based on representative models marked *. Others similar.

**Based on lower measurement of maximum line pull that the tractor can develop with the standard gear ratio, or the breaking strength of the maximum recommended wire.

WINCH MODEL		W8L	W12E		
TRACTOR MODEL		D7R*, 572R	D8T*, PL83, PL87	D9T	D10T
Winch drive		PTO	PTO	PTO	PTO
Winch type.		Standard	Standard	Standard	Standard
British Units of Measure					
Bare Drum	Maximum line pull** lb	112,500	138,800	138,800	138,800
	Line speed at fpm	122	52	55	53
	Typical line pull of lb	50,000	80,000	80,000	80,000
	Maximum line speed fpm	168	59	60	58
Full Drum	Maximum line pull** lb	81,700	138,800	138,800	138,800
	Line speed at fpm	115	78	82	81
	Typical line pull of lb	50,000	80,000	80,000	80,000
	Maximum line speed fpm	275	92	93	91
Metric Units of Measure					
Bare Drum	Maximum line pull** kg	51 030	62 960	62 960	62 960
	Line speed at m/min	37.2	15.8	16.8	16.2
	Typical line pull of kg	22 700	36 287	36 287	36 287
	Maximum line speed m/min	51.2	18.0	18.3	17.7
Full Drum	Maximum line pull** kg	37 058	62 959	62 959	62 959
	Line speed at m/min	35.1	23.8	25.0	24.7
	Typical line pull of kg	22 700	36 287	36 287	36 287
	Maximum line speed m/min	83.8	28.0	28.3	27.7

Performance based on standard gear ratio. Optional gear ratios available for different line speed and line pull requirements.

*Specifications based on representative models marked *. Others similar.

**Based on lower measurement of maximum line pull that the tractor can develop with the standard gear ratio, or the breaking strength of the maximum recommended wire.

UNDERGROUND MINING EQUIPMENT

Hard Rock Longwall Room & Pillar

20

CONTENTS

HARD ROCK

Features	20-3
Load-Haul-Dumps (LHDs):	
Specifications	20-4
Dimensions and Capacities	20-6
Bucket Selection	20-7
Turning Dimensions	20-7
Curves:	
R1300G Rimpull-Speed-Gradeability	20-8
R1600H Rimpull-Speed-Gradeability	20-9
R1700G Rimpull-Speed-Gradeability	20-10
R2900G Rimpull-Speed-Gradeability	20-11
R3000H Rimpull-Speed-Gradeability	20-12

HARD ROCK (continued)

Articulated Trucks:	
Specifications	20-13
Dimensions and Capacities	20-15
Curves:	
AD30 Rimpull-Speed-Gradeability	20-17
AD45B Rimpull-Speed-Gradeability	20-18
AD55 Rimpull-Speed-Gradeability	20-19
AD60 Rimpull-Speed-Gradeability	20-20
LHD and Truck Systems	20-21
Rock Flow System:	
Introduction	20-22
Features	20-22
Specifications:	
Rock Feeder	20-23
Rock Mover	20-23

LONGWALL

Introduction	20-26
Roof Supports:	
Features	20-26
Specifications	20-27
Special Applications	20-28
AFC Systems:	
Features	20-29
Specifications	20-30
Dimensions	20-34
Conveying Performance	20-39
Beam Stage Loaders (BSL):	
Features	20-42
Specifications	20-42
CST Drive Systems:	
Features	20-45
Specifications	20-46
Rated Power P/Gearbox Ratio $i [-]$	20-52
Variable Frequency Drives (VFD):	
Features	20-54
Specifications	20-55
Dimensions	20-56
Shearers:	
Features	20-57
Specifications	20-58
Dimensions	20-65
Optional Accessories	20-75
Automated Plow Systems:	
Features	20-76
Specifications	20-77
Dimensions	20-79
Programmable Mining Controls:	
PMC-R:	
Features	20-97
Specifications	20-97
PMC-D and PMC-V:	
Features	20-101
Specifications	20-101
MCU2:	
Features	20-105
Specifications	20-105
Roof Support Carriers:	
Features	20-107
Specifications	20-108
Dimensions	20-110
Tractive Effort vs. Speed — Loaded	20-112
% Grade vs. Speed — Loaded	20-113
Lift Capability	20-114
Shield Trailers:	
Features	20-115
Specifications	20-116
Dimensions	20-117
SH150 Load Setting Table	20-118

ROOM & PILLAR

Introduction	20-121
Continuous Miners:	
Features	20-122
Specifications	20-123
Face Haulers:	
Features	20-126
Specifications	20-127
Dimensions	20-128
Continuous Haulage System:	
Features	20-129
Specifications	20-130
Dimensions	20-131
Feeder Breakers:	
Features	20-132
Specifications	20-133
Roof Bolter:	
Features	20-134
Specifications	20-135
Scoops:	
Features	20-136
Specifications	20-137
LHD Vehicles (Load-Haul-Dumps):	
Features	20-138
Specifications	20-139
Tractive Effort vs. Speed — Loaded	20-141
% Grade vs. Speed — Loaded	20-143
Lift Capability	20-145
Bucket Load Capacities	20-147

HARD ROCK Load-Haul-Dumps (LHDs) Articulated Trucks Rock Flow System

20

CONTENTS

HARD ROCK

Features.....	20-3
Load-Haul-Dumps (LHDs):	
Specifications	20-4
Dimensions and Capacities	20-6
Bucket Selection	20-7
Turning Dimensions	20-7
Curves:	
R1300G Rimpull-Speed-Gradeability.....	20-8
R1600H Rimpull-Speed-Gradeability.....	20-9
R1700G Rimpull-Speed-Gradeability.....	20-10
R2900G Rimpull-Speed-Gradeability.....	20-11
R3000H Rimpull-Speed-Gradeability.....	20-12
Articulated Trucks:	
Specifications	20-13
Dimensions and Capacities	20-15
Curves:	
AD30 Rimpull-Speed-Gradeability	20-17
AD45B Rimpull-Speed-Gradeability	20-18
AD55 Rimpull-Speed-Gradeability.....	20-19
AD60 Rimpull-Speed-Gradeability	20-20
LHD and Truck Systems	20-21
Rock Flow System:	
Introduction	20-22
Features.....	20-22
Specifications:	
Rock Feeder	20-23
Rock Mover.....	20-23

Features, all models:

- Rugged design for underground application.
- Engineered for productivity, reliability, safety and machine rebuildability.
- Extensive use of steel castings and forgings.
- Cat® heavy duty diesel engines and power trains.
- Computerized machine function monitoring.
- Four wheel enclosed wet disc brakes.
- Remote Control Interface Group options on loaders.
- Payload control system option on loaders.
- Ride control system optional on loaders.
- Fully enclosed air conditioned operator stations available.
- Operator Stations are FOPS certified.

Product Line:

- Five models of Load-Haul-Dump (LHD) machines, with rated bucket payloads ranging from 6800 kg (14,991 lb) to 20 000 kg (44,100 lb).
- Four models of articulated dump trucks, with payload capacities of 30 000 kg (66,140 lb) to 60 000 kg (132,277 lb).

MODEL	R1300G		R1600H	
Engine Model	3306B		C11 ACERT™	
Gross Power — SAE J1995	123 kW	165 hp	—	—
Gross Power — VR Engine — SAE J1995	—	—	208 kW	279 hp
Gross Power — U.S. EPA Tier 3 equivalent Engine — SAE J1995	—	—	208 kW	279 hp
Tire Size	17.5 × R25		18 × R25	
Nominal Payload Capacity — Tramming	6800 kg	14,991 lb	10 200 kg	22,487 lb
Nominal Payload Capacity — Truck Loading	6800 kg	14,991 lb	10 200 kg	22,487 lb
Gross Machine Mass	27 750 kg	61,178 lb	44 204 kg	97,453 lb
Bucket Size — Minimum	2.4 m ³	3.1 yd³	4.2 m ³	5.5 yd³
Bucket Size — Maximum	3.4 m ³	4.4 yd³	5.9 m ³	7.7 yd³
Length — Overall Digging	9107 mm	358.5"	10 107 mm	397.9"
— Overall Tramming	8714 mm	343.1"	9711 mm	382.3"
— Wheel Base	3050 mm	120"	3536 mm	139.2"
Width — Overall with Bucket	2318 mm	91.3"	2723 mm	107.2"
— Overall without Bucket	2071 mm	81.5"	2567 mm	101.1"
— OverTires	1900 mm	74.8"	2404 mm	94.6"
Height — Overall Bucket Raised	4302 mm	169.4"	5204 mm	204.9"
— Maximum Bucket Pin	2918 mm	114.9"	3752 mm	147.7"
— Top of ROPS	2120 mm	83.5"	2400 mm	94.5"
— Dump Clearance	1560 mm	61.4"	2207 mm	86.9"
— Ground Clearance	328 mm	12.9"	344 mm	13.5"
Turning Radius — Outer Clearance	5741 mm	226"	6638 mm	261.3"
— Inner Clearance	2825 mm	111.2"	3291 mm	129.6"
Angle — Articulation	±42.5°		±42.5°	
— Rear Axle Oscillation	±10.0°		±10.0°	
— Maximum Bucket Dump	43°		45°	
Hydraulic Cycle Time:				
Raise	5.0 Sec.		7.6 Sec.	
Dump	2.0 Sec.		1.6 Sec.	
Lower	2.3 Sec.		2.0 Sec.	
Total	9.3 Sec.		11.2 Sec.	
Travel Speeds:	km/h	mph	km/h	mph
Forward — 1st	5.0	3.1	5.0	3.1
— 2nd	9.0	5.6	8.7	5.4
— 3rd	17.0	10.6	15.2	9.5
— 4th	24.0	14.9	22.1	13.7
Reverse — 1st	5.0	3.1	5.7	3.5
— 2nd	8.0	5.0	9.9	6.1
— 3rd	15.0	9.3	17.2	10.7
— 4th	23.0	14.3	23.8	14.8
Tilt Break Out Force SAE	12 020 kg	26,500 lb	17 928 kg	39,524 lb
Lift Break Out Force SAE	11 750 kg	25,909 lb	19 202 kg	42,333 lb
Static Tipping Load — Straight* (\$) — Full Turn* (\$) —	20 575 kg	45,360 lb	25 905 kg	57,110 lb
	17 870 kg	39,397 lb	20 896 kg	46,067 lb
Refill Capacity:				
Fuel	295 L	78 U.S. gal	415/749 L+	109/198 U.S. gal+
Engine Crankcase with Filter	25 L	6.6 U.S. gal	34 L	8.9 U.S. gal
Transmission	45 L	11.9 U.S. gal	47 L	12.4 U.S. gal
Hydraulic Tank	88 L	23.2 U.S. gal	125 L	33 U.S. gal
Cooling System	67 L	17.7 U.S. gal	53 L	14 U.S. gal

*Static tipping loads shown are for unoptioned standard machines with standard bucket and tires, full fuel tank and operator at 75 kg (165 lb), as per SAE J732 JUN92 5.2.

+Standard fuel tank/With secondary fuel tank.

MODEL	R1700G		R2900G		R3000H	
	C11 ACERT		C15 ACERT		C15 ACERT	
Engine Model						
Gross Power — VR Engine — SAE J1995	263 kW	253 hp	305 kW	409 hp	305 kW	409 hp
Gross Power — Tier 3 equivalent Engine — SAE J1995	242/263+ kW	324/353+ hp	305 kW	409 hp	305 kW	409 hp
Tire Size	26.5 × R25		29.5 × 29		35/65 R33	
Nominal Payload Capacity:						
— Trimming	14 000 kg	30,865 lb	17 200 kg	37,920 lb	20 000 kg	44,092 lb
— Truck Loading	12 500 kg	27,558 lb	17 200 kg	37,920 lb	20 000 kg	44,092 lb
Gross Machine Mass	55 000 kg	121,254 lb	70 350 kg	155,095 lb	80 410 kg	177,273 lb
Bucket Size — Minimum	4.6 m ³	6.0 yd³	6.3 m ³	8.2 yd³	8.3 m ³	10.9 yd³
Bucket Size — Maximum	8.8 m ³	11.5 yd³	8.9 m ³	11.6 yd³	11.6 m ³	15.2 yd³
Length — Overall Digging	10 973 mm	416.9"	11 302 mm	445.0"	11 493 mm	452.5"
— Overall Trimming	10 589 mm	416.9"	10 949 mm	431.1"	11 150 mm	439.0"
— Wheel Base	3680 mm	144.9"	3780 mm	148.8"	3780 mm	148.8"
Width — Overall with Bucket	2894 mm	113.9"	3176 mm	125.0"	3454 mm	136.0"
— Overall without Bucket	2689 mm	105.8"	3010 mm	118.5"	3200 mm	126.0"
— OverTires	2650 mm	104.3"	2898 mm	114.1"	3266 mm	128.6"
Height — Overall Bucket Raised	5606 mm	220.7"	6179 mm	243.3"	6283 mm	247.4"
— Maximum Bucket Pin	4014 mm	161.6"	4539 mm	178.7"	4553 mm	179.3"
— Top of ROPS	2557 mm	100.7"	2886 mm	113.6"	3002 mm	118.2"
— Dump Clearance	2443 mm	96.2"	2868 mm	112.9"	2744 mm	108.0"
— Ground Clearance	429 mm	16.9"	465 mm	18.3"	476 mm	18.7"
Turning Radius — Outer Clearance	6878 mm	270.8"	7323 mm	288.3"	7536 mm	296.7"
— Inner Clearance	3229 mm	127.1"	3383 mm	133.2"	3247 mm	127.8"
Angle — Articulation	±44.0°		±42.5°		±42.5°	
— Rear Axle Oscillation	±8.0°		±8.0°		±8.0°	
— Maximum Bucket Dump	46°		42°		42°	
Hydraulic Cycle Time:						
Raise	6.8 Sec.		9.2 Sec.		8.8 Sec.	
Dump	2.9 Sec.		3.4 Sec.		1.85 Sec.	
Lower	2.4 Sec.		3.1 Sec.		3.5 Sec.	
Total	12.1 Sec.		15.7 Sec.		14.2 Sec.	
Travel Speeds:	km/h	mph	km/h	mph	km/h	mph
Forward — 1st	4.7	2.9	5.4	3.4	5.5	3.4
— 2nd	8.3	5.2	9.7	6.0	9.7	6.0
— 3rd	14.3	8.9	17.3	10.7	17.3	10.7
— 4th	24.1	15.0	29.8	18.5	31.6	19.6
Reverse — 1st	5.4	3.3	6.6	4.1	6.7	4.1
— 2nd	9.4	5.8	11.8	7.3	12.3	7.6
— 3rd	16.4	10.2	21.0	13.0	21.6	13.4
— 4th	25.3	15.7	35.5	22.0	33.8	21.0
Tilt Break Out Force SAE	20 885 kg	46,051 lb	27 346 kg	60,298 lb	28 020 kg	61,784 lb
Lift Break Out Force SAE	10 633 kg	23,446 lb	22 704 kg	50,062 lb	26 817 kg	59,131 lb
Static Tipping Load — Straight*(§)	31 781 kg	70,065 lb	39 923 kg	88,015 lb	47 264 kg	104,199 lb
— Full Turn*(§)	26 306 kg	57,995 lb	34 069 kg	75,109 lb	40 003 kg	88,191 lb
Refill Capacity:						
Fuel	569/ 1015 L++	150.3/268.1 U.S. gal++	1425 L	376.4 U.S. gal	1539 L	406.9 U.S. gal
Engine Crankcase with Filter	34 L	8.98 U.S. gal	34 L	9.0 U.S. gal	34 L	9.0 U.S. gal
Transmission	47 L	12.4 U.S. gal	62 L	16.4 U.S. gal	62 L	16.4 U.S. gal
Hydraulic Tank	125 L	33 U.S. gal	140 L	37.0 U.S. gal	140 L	37.0 U.S. gal
Cooling System	63 L	16.6 U.S. gal	75 L	19.8 U.S. gal	75 L	19.8 U.S. gal

*Static tipping loads shown are for unoptioned standard machines with standard bucket and tires, full fuel tank and operator at 75 kg (165 lb), as per SAE J732 JUN92 5.2.

+Dual Horsepower — Higher horsepower for different gears (1st-3rd gear/4th gear).

++Standard fuel tank/With secondary fuel tank.

Model	R1300G		R1600H		R1700G	
Nominal Payload Capacity:						
– Trimming	6800 kg	14,991 lb	10 200 kg	22,487 lb	14 000 kg	30,865 lb
– Truck Loading	6800 kg	14,991 lb	10 200 kg	22,487 lb	12 500 kg	27,558 lb
Gross Machine Mass	27 750 kg	61,178 lb	44 204 kg	97,453 lb	55 000 kg	121,254 lb
Bucket Capacity — Standard	3.1 m ³	4.1 yd³	4.8 m ³	6.3 yd³	5.7 m ³	7.5 yd³
Overall Width with Bucket	2318 mm	91.3"	2723 mm	107.2"	2894 mm	113.9"
Overall Height — Top of ROPS	2120 mm	83.5"	2400 mm	94.5"	2557 mm	100.7"
Length — Overall Digging	9107 mm	358.5"	10 107 mm	397.9"	10 973 mm	432.0"
– Overall Trimming	8714 mm	343.1"	9711 mm	382.3"	10 589 mm	416.9"
Operating Weight	20 950 kg	46,187 lb	30 150 kg	66,469 lb	38 500 kg	84,878 lb
Ground Clearance	328 mm	12.9"	344 mm	13.5"	429 mm	16.9"
Axle Oscillation	± 10.0°		± 10.0°		± 8.0°	

Model	R2900G		R3000H	
Nominal Payload Capacity:				
– Trimming	17 200 kg	37,920 lb	20 000 kg	44,092 lb
– Truck Loading	17 200 kg	37,920 lb	20 000 kg	44,092 lb
Gross Machine Mass	70 350 kg	155,095 lb	80 410 kg	177,273 lb
Bucket Capacity — Standard	7.2 m ³	9.4 yd³	8.9 m ³	11.6 yd³
Overall Width with Bucket	3176 mm	125.0"	3454 mm	136.0"
Overall Height — Top of ROPS	2886 mm	113.6"	3002 mm	118.2"
Length — Overall Digging	11 302 mm	445.0"	11 493 mm	452.5"
– Overall Trimming	10 949 mm	431.1"	11 150 mm	439.0"
Operating Weight	50 209 kg	110,692 lb	56 055 kg	123,580 lb
Ground Clearance	465 mm	18.3"	476 mm	18.7"
Axle Oscillation	± 8.0°		± 8.0°	

Model	Bucket Type	SAE Capacity	
		m³	yd³
R1300G	Standard	2.4	3.1
	Standard	2.8	3.6
	Standard	3.1	4.1
	Standard	3.4	4.5
	Ejector	2.4	3.1
R1600H	Standard	4.2	5.5
	Standard	4.8	6.3
	Standard	5.6	7.3
	Standard	5.9	7.7
	Ejector	4.8	6.3
R1700G	Standard*	4.6	6.0
	Standard*	5.0	6.5
	Standard*	5.7	7.5
	Standard*	6.6	8.6
	Standard*	7.3	9.5
	Light Materials Ejector	8.8 5.7	11.5 7.5

Model	Bucket Type	SAE Capacity	
		m³	yd³
R2900G	Standard	6.3	8.2
	Standard*	7.2	9.4
	Standard*	8.3	10.9
	Standard*	8.9	11.6
R3000H	Standard*	8.3	10.9
	Standard*	8.9	11.6
	Standard*	10.5	13.7
	Light Materials	11.6	15.2

*High Penetration Bucket available.

- Bucket Selection
- Turning Dimensions

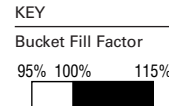
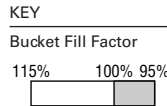
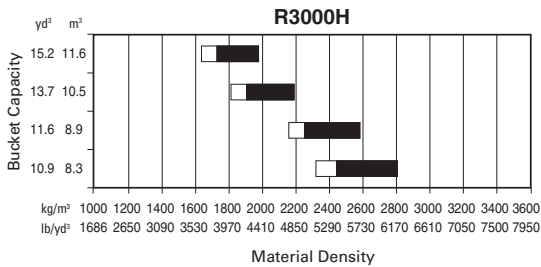
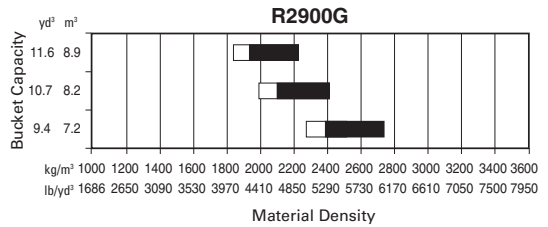
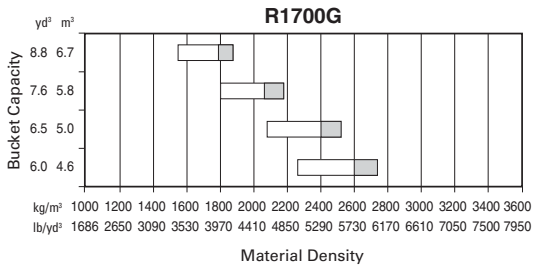
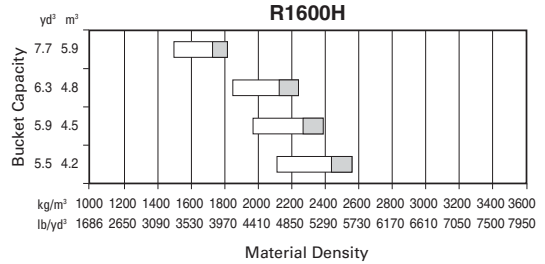
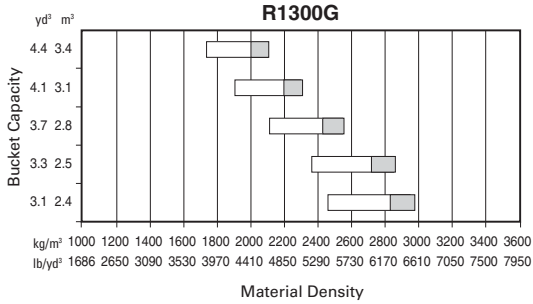

Turning Dimensions

Model	R1300G	R1600H	R1700G	R2900G	R3000H
Outer Turning Radius	5741 mm 226"	6638 mm 261.3"	6878 mm 270.8"	7323 mm 288.3"	7536 mm 296.7"
Inner Turning Radius	2825 mm 111.2"	3291 mm 129.6"	3229 mm 127.1"	3383 mm 133.2"	3247 mm 127.8"
Articulation Angle	±42.5°	±42.5°	±44.0°	±42.5°	±42.5°

Hard Rock

- Load-Haul-Dumps (LHDs)
- R1300G Rimpull-Speed-Gradeability
- 17.5x25 Tires

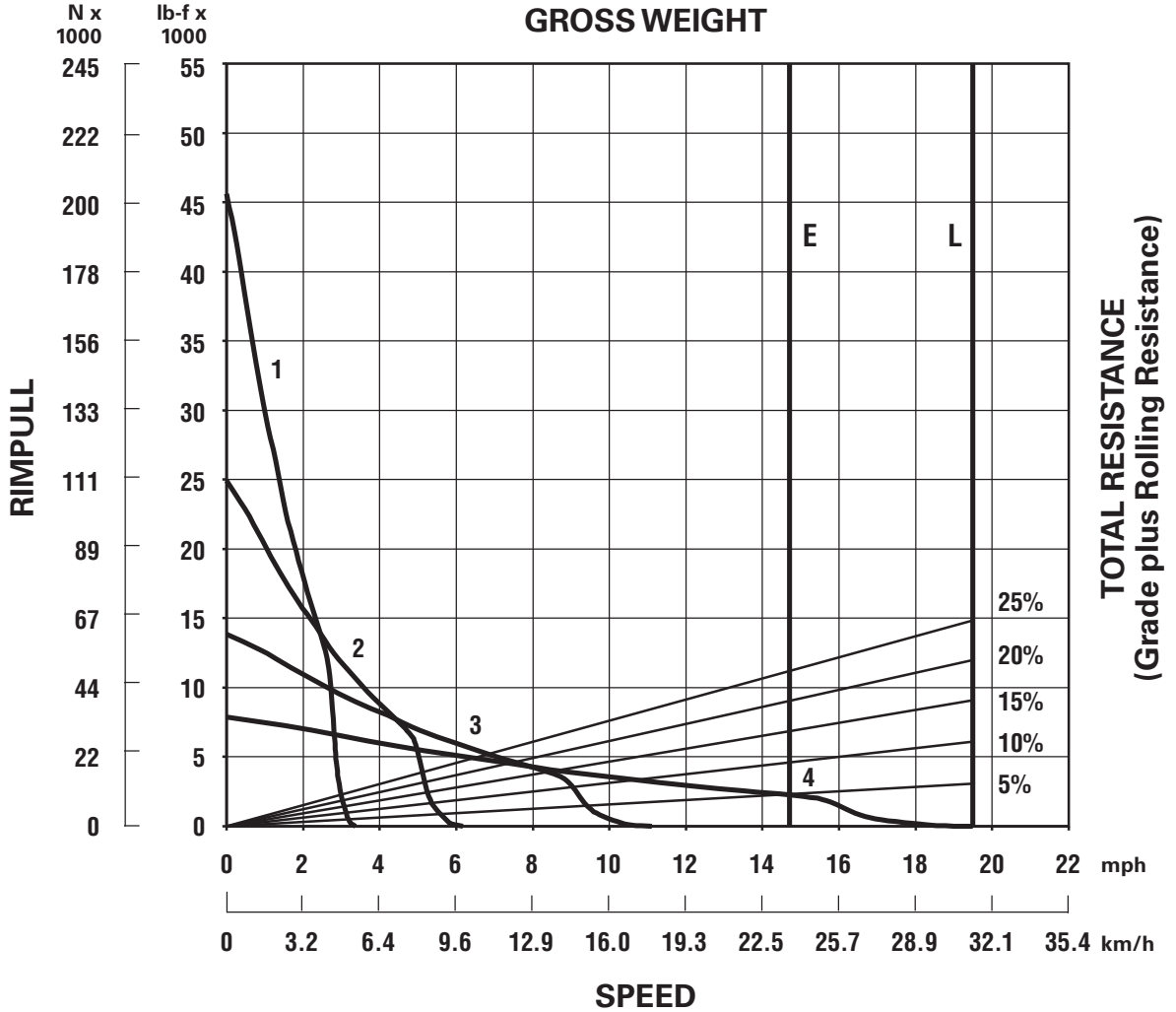

KEY

- 1 — 1st Gear
- 2 — 2nd Gear
- 3 — 3rd Gear
- 4 — 4th Gear

KEY

- E — Empty 20 950 kg (46,187 lb)
- L — Loaded 27 750 kg (61,178 lb)

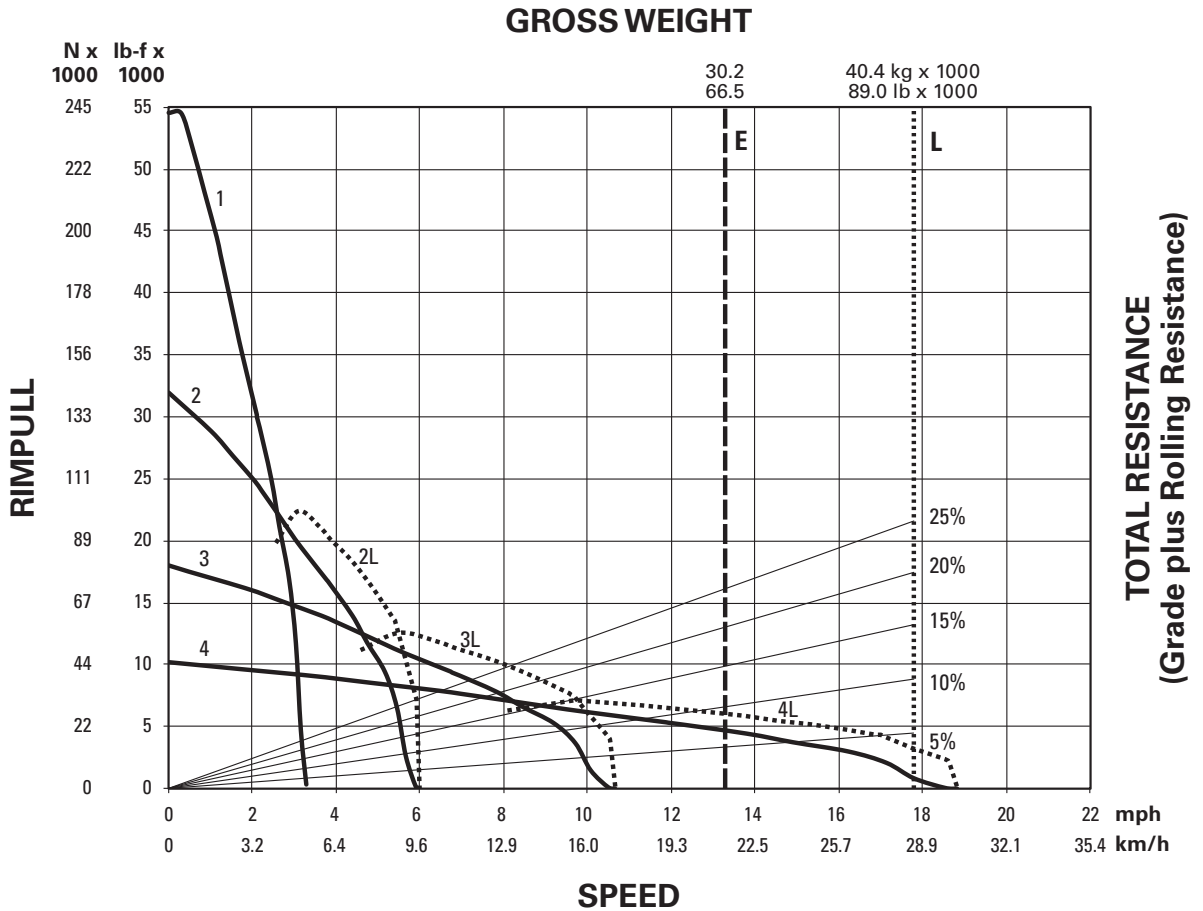

KEY

- 1 — 1st Gear
- 2 — 2nd Gear
- 2L — 2nd Gear (Lockup Clutch)
- 3 — 3rd Gear
- 3L — 3rd Gear (Lockup Clutch)
- 4 — 4th Gear
- 4L — 4th Gear (Lockup Clutch)

KEY

- E — Empty 30 150 kg (66,470 lb)
- L — Loaded 40 350 kg (88,956 lb)

Hard Rock

Load-Haul-Dumps (LHDs)

- R1700G Rimpull-Speed-Gradeability

- 26.5x25 Tires

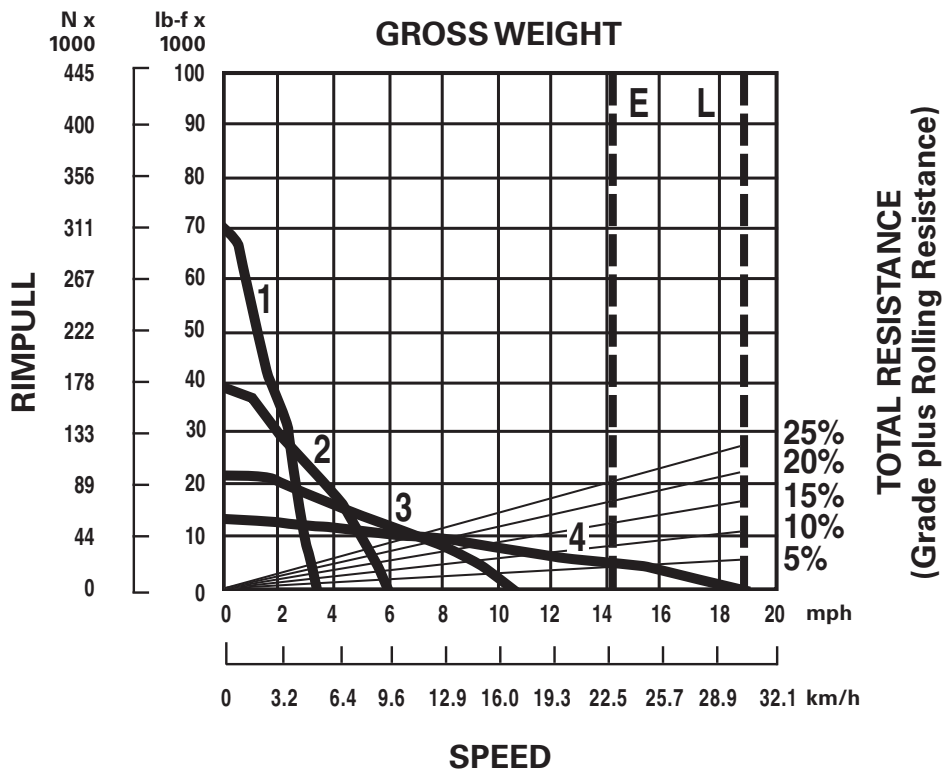

KEY

- 1 — 1st Gear
- 2 — 2nd Gear
- 3 — 3rd Gear
- 4 — 4th Gear

KEY

- E — Empty 38 500 kg (84,878 lb)
- L — Loaded 51 000 kg (112,436 lb)

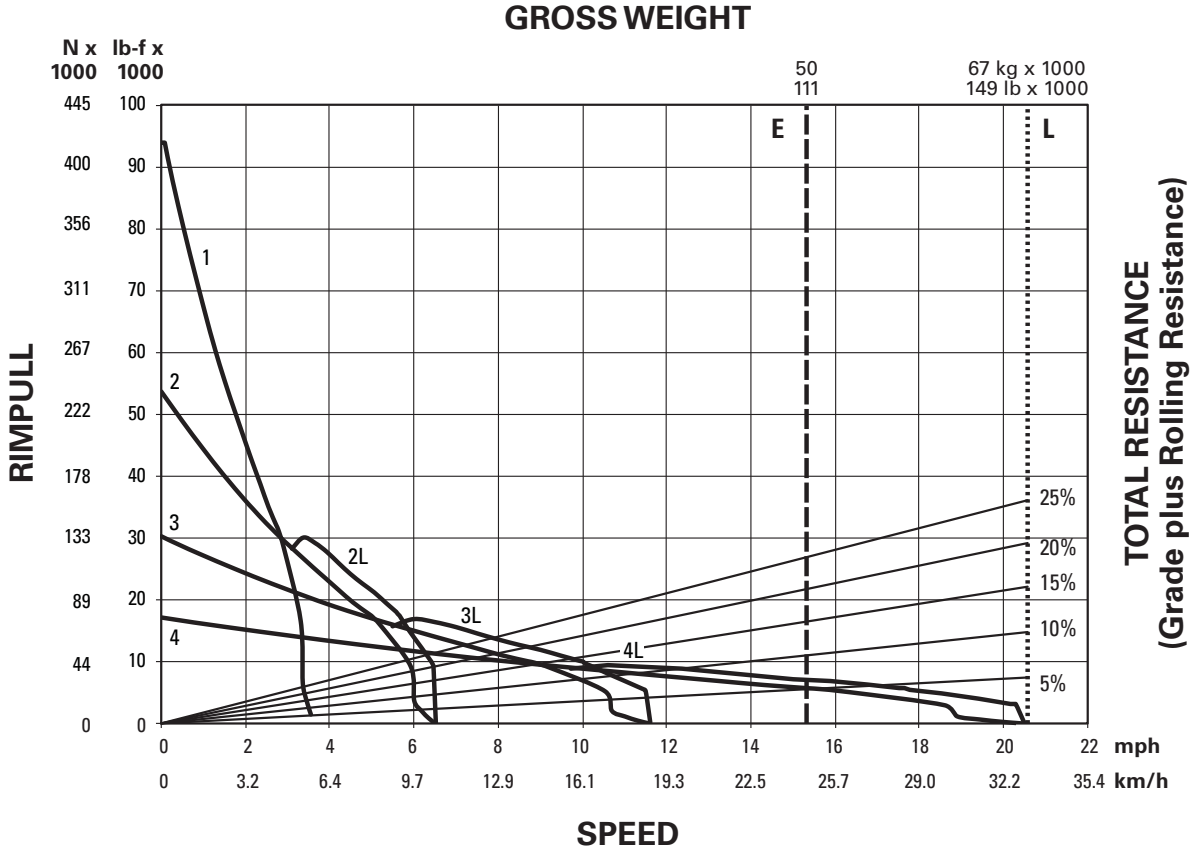

- KEY**
- 1 — 1st Gear
 - 2 — 2nd Gear
 - 2L — 2nd Gear (Lockup Clutch)
 - 3 — 3rd Gear
 - 3L — 3rd Gear (Lockup Clutch)
 - 4 — 4th Gear
 - 4L — 4th Gear (Lockup Clutch)

- KEY**
- E — Empty 50 209 kg (110,692 lb)
 - L — Loaded 67 409 kg (148,611 lb)

Hard Rock

Load-Haul-Dumps (LHDs)

- R3000H RCM00101 and Up Rimpull-Speed-Gradeability
- 35/65R33 Tires

GROSS WEIGHT

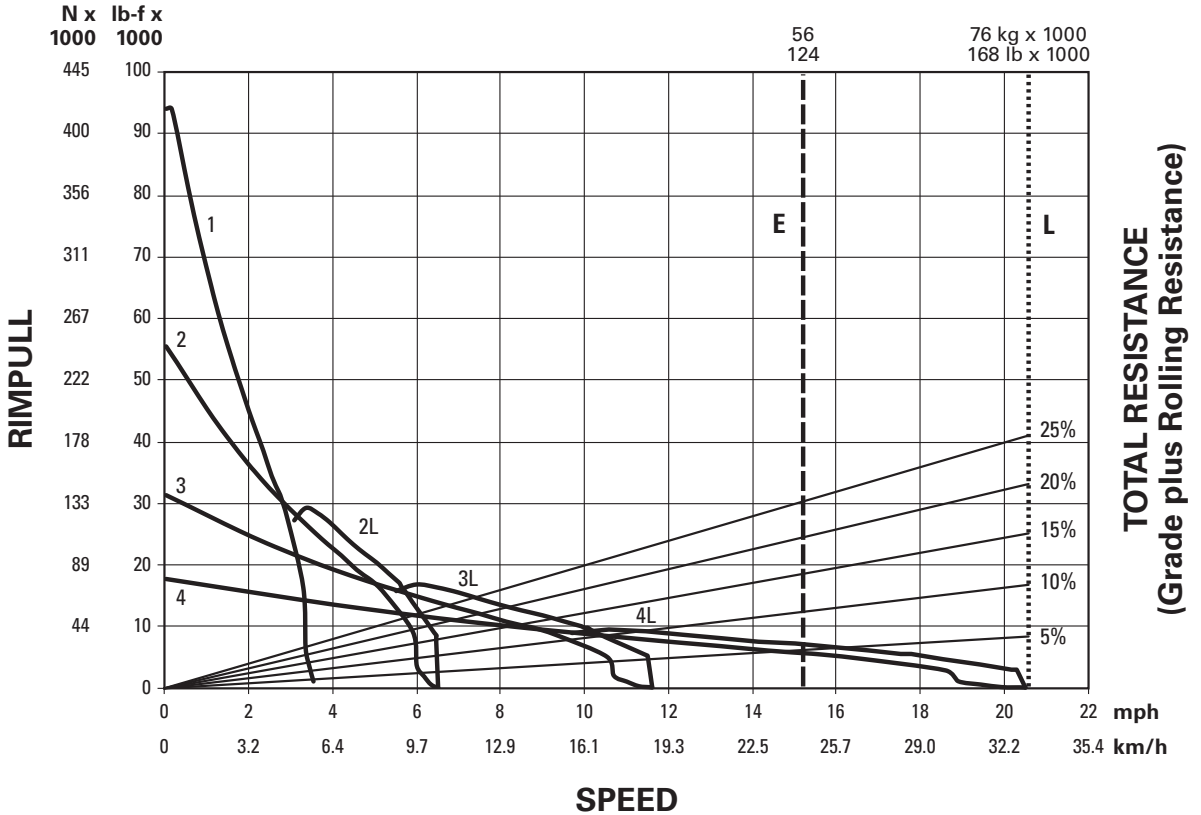

KEY

- 1 — 1st Gear
- 2 — 2nd Gear
- 2L — 2nd Gear (Lockup Clutch)
- 3 — 3rd Gear
- 3L — 3rd Gear (Lockup Clutch)
- 4 — 4th Gear
- 4L — 4th Gear (Lockup Clutch)

KEY

- E — Empty 56 055 kg (123,580 lb)
- L — Loaded 76 055 kg (167,672 lb)

MODEL	AD30		AD45B	
	C15 ACERT		C18 ACERT	
Engine Model				
Engine Power:				
– Gross Power – VR Engine – SAE J1995	305 kW	409 hp	439 kW	589 hp
– Gross Power – Tier 3 equivalent Engine – SAE J1995	305 kW	409 hp	439 kW	589 hp
Tire Size	26.5 × R25		29.5 × R29	
Nominal Payload Capacity	30 000 kg	66,138 lb	45 000 kg	86,772 lb
Gross Machine Operating Weight	60 000 kg	132,277 lb	85 000 kg	187,393 lb
Body Capacity* – Standard Dump Body	14.4 m ³	18.8 yd³	21.3 m ³	27.9 yd³
Weight Distribution:				
– Empty (Front/Rear)	67.5%/32.5%		69.0%/31.0%	
– Loaded (Front/Rear)	44.2%/55.8%		45.6%/54.4%	
Length – Overall	10 153 mm	399.7"	11 194 mm	440.7"
Width – Overall	2690 mm	105.9"	3000 mm	118.1"
Height:				
– Overall Body Raised	5602 mm	220.5"	6357 mm	250.3"
– Top of ROPS	2600 mm	102.4"	2817 mm	110.9"
– Loading Height	2385 mm	93.9"	2925 mm	115.2"
– Ground Clearance	400 mm	15.7"	441 mm	17"
Clearance Radius:				
– Outer Clearance	8571 mm	337.7"	9291 mm	365.8"
– Inner Clearance	5030 mm	198"	5310 mm	209"
Angle:				
– Articulation	±42.5°		±42.5°	
– Oscillation	±10.0°		±10.0°	
Body Hoist Cycle Time:				
Raise Time	10.5 Sec.		16.0 Sec.	
Dump Time	11.2 Sec.		21.0 Sec.	
Total Cycle Time	21.7 Sec.		37.0 Sec.	
Travel Speeds:	km/h	mph	km/h	mph
Forward – 1st	6.8	4.2	8.0	4.9
– 2nd	12.3	7.6	10.9	6.8
– 3rd	22.3	13.9	15.1	9.4
– 4th	40.8	25.4	20.6	12.8
– 5th	–	–	28.1	17.5
– 6th	–	–	38.1	23.7
– 7th	–	–	52.0	32.3
Reverse – 1st	7.8	4.8	7.5	4.6
– 2nd	–	–	10.1	6.3
Refill Capacity:				
Fuel	500 L	132 U.S. gal	764 L	202 U.S. gal
Engine Crankcase with Filter	38 L	10 U.S. gal	64 L	17 U.S. gal
Transmission	67 L	18 U.S. gal	60 L	16 U.S. gal
Hydraulic Tank	145 L	38 U.S. gal	266 L	70 U.S. gal
Cooling System	76 L	20 U.S. gal	85 L	23 U.S. gal

*Heaped SAE 2:1.

MODEL	AD55		AD60	
	C18 ACERT		C27 ACERT	
Engine Model				
Engine Power:				
– Gross Power – VR Engine – SAE J1995	439 kW	589 hp	600 kW	805 hp
– Gross Power – Tier 3 equivalent Engine – SAE J1995	439 kW	589 hp	540/560 kW+	725/751 hp+
Tire Size	35 × 65 R33		35 × 65 R33	
Nominal Payload Capacity	55 000 kg	121,254 lb	60 000 kg	132,277 lb
Gross Machine Operating Weight	102 000 kg	226,871 lb	112 000 kg	246,917 lb
Body Capacity* – Dump Body	26.9 m ³	35.2 yd³	26.9 m ³	35.2 yd³
Weight Distribution:				
– Empty (Front/Rear)	66.4%/34.2%		70.5%/29.5%	
– Loaded (Front/Rear)	47.6%/53.4%		50.0%/50.0%	
Length – Overall	11 523 mm	454"	12 040 mm	474"
Width – Overall	3250 mm	128"	3346 mm	131.7"
Height:				
– Overall Body Raised	6969 mm	274"	6969 mm	274.4"
– Top of ROPS	3000 mm	118"	3000 mm	118.1"
– Loading Height	3045 mm	120"	3045 mm	119.9"
– Ground Clearance	391 mm	15"	393 mm	15.5"
Clearance Radius:				
– Outer	9885 mm	389"	10 005 mm	393.9"
– Inner	5540 mm	218"	5540 mm	218.1"
Angle:				
– Articulation	±42.5°		±42.5°	
– Oscillation	±10.0°		±10.0°	
Body Hoist Cycle Time:				
Raise Time	12.0 Sec.		12.0 Sec.	
Dump Time	24.0 Sec.		24.0 Sec.	
Total Cycle Time	36.0 Sec.		36.0 Sec.	
Travel Speeds:	km/h	mph	km/h	mph
Forward – 1st	7.0	4.4	6.6	4.1
– 2nd	9.6	5.9	9.3	5.8
– 3rd	13.0	8.1	12.5	7.5
– 4th	17.5	10.8	16.8	10.4
– 5th	23.7	14.7	22.7	14.1
– 6th	31.9	19.8	30.7	19.1
– 7th	43.3	26.9	41.5	25.8
Reverse – 1st	6.8	4.2	8.7	5.4
– 2nd	9.2	5.7	–	–
Refill Capacity:				
Fuel	940 L	248.3 U.S. gal	940 L	248.3 U.S. gal
Engine Crankcase with Filter	64 L	17 U.S. gal	99 L	26 U.S. gal
Transmission	53 L	14 U.S. gal	53 L	14 U.S. gal
Hydraulic Tank	258 L	68 U.S. gal	258 L	68 U.S. gal
Cooling System	75 L	20 U.S. gal	138 L	37 U.S. gal

*Heaped SAE 2:1.

+Dual Horsepower – Higher horsepower for different gears.

Articulated Trucks

Model	AD30		AD45B	
Nominal Payload Capacity	30 000 kg	66,138 lb	45 000 kg	99,208 lb
Gross Machine Operating Weight	60 000 kg	132,277 lb	85 000 kg	187,393 lb
Body Capacity* — Standard Dump Body	14.4 m ³	18.8 yd³	21.3 m ³	27.9 yd³
Overall Length	10 153 mm	399.7"	11 194 mm	440.7"
Overall Width	2690 mm	105.9"	3000 mm	118.1"
Overall Height	2600 mm	102.4"	3036 mm	119.5"
Ground Clearance	400 mm	15.7"	441 mm	17"
Frame Oscillation	±10.0°		±10.0°	

Model	AD55		AD60	
Nominal Payload Capacity	55 000 kg	121,254 lb	60 000 kg	132,277 lb
Gross Machine Operating Weight	102 000 kg	226,871 lb	112 000 kg	246,917 lb
Body Capacity* — Dump Body	26.9 m ³	35.2 yd³	26.9 m ³	35.2 yd³
Overall Length	11 523 mm	454"	12 040 mm	474"
Overall Width	3250 mm	128"	3346 mm	131.7"
Overall Height	3000 mm	118"	3202 mm	126.1"
Ground Clearance	391 mm	15"	393 mm	15.5"
Frame Oscillation	±10.0°		±10.0°	

*2:1 per SAE.

Model	Body Type	SAE Body Capacity	
		m ³	yd ³
AD30	Dump	11.3	14.8
	Dump	14.4	18.8
	Dump	17.5	22.9
	Wide Body	16.8	21.9
	Ejector Body	15.2	19.9
	Ejector Body	16.8	21.9
AD45B	Dump	18.0	23.5
	Dump	21.3	27.9
	Dump	25.1	32.8
	Ejector Body	22.9	29.9

Model	Body Type	SAE Body Capacity	
		m ³	yd ³
AD55	Dump	26.9	35.2
	Dump	32.6	42.6
	Dump	33.8	44.2
	Dump	36.6	47.9
	Dump	36.6	47.9
AD60	Dump	26.9	35.2
	Dump	32.6	42.6
	Dump	33.8	44.2
	Dump	36.6	47.9
	Ejector Body	26.9	35.2
Ejector Body	29.4	38.5	

Turning Dimensions

Articulated Trucks

Model — Standard Body	AD30		AD45B	
Clearance Radius — Outer	8571 mm	337.4"	9291 mm	365.8"
Clearance Radius — Inner	5030 mm	198.0"	5310 mm	209.0"
Angle — Articulation	±42.5°		±42.5°	

Model — Standard Body	AD55		AD60	
Clearance Radius — Outer	9885 mm	389.0"	10 005 mm	393.9"
Clearance Radius — Inner	5540 mm	218.1"	5540 mm	218.1"
Angle — Articulation	±42.5°		±42.5°	

Model — Ejector Body	AD30		AD45B	
Clearance Radius — Outer	8571 mm	337.5"	9291 mm	365.8"
Clearance Radius — Inner	4935 mm	194.3"	5210 mm	205.0"
Angle — Articulation	±42.5°		±42.5°	

Model — Ejector Body	AD55		AD60	
Clearance Radius — Outer	N/A		10 005 mm	393.9"
Clearance Radius — Inner	N/A		5419 mm	213.4"
Angle — Articulation	N/A		±42.5°	

N/A = Not Available

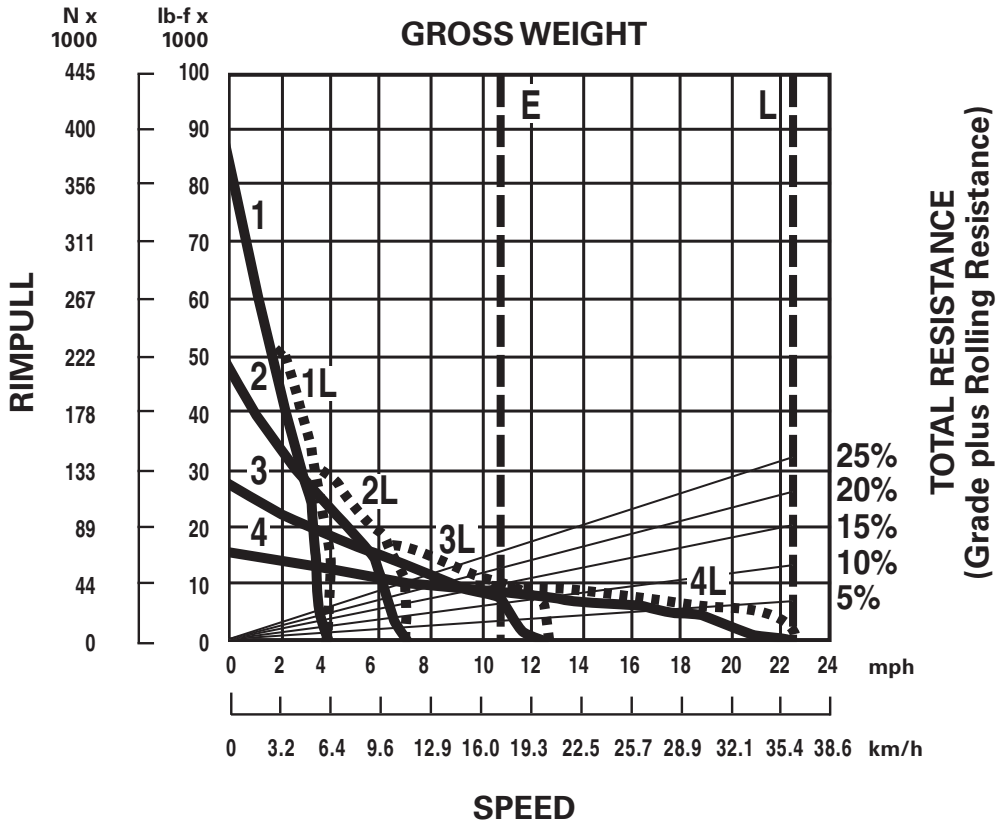

KEY

- 1 — 1st Gear
- 2 — 2nd Gear
- 3 — 3rd Gear
- 4 — 4th Gear

KEY

- E — Empty 28 870 kg (63,647 lb)
- L — Loaded 60 000 kg (132,277 lb)

Hard Rock

Articulated Trucks

- AD45B Rimpull-Speed-Gradeability
- 29.5R29 Tires

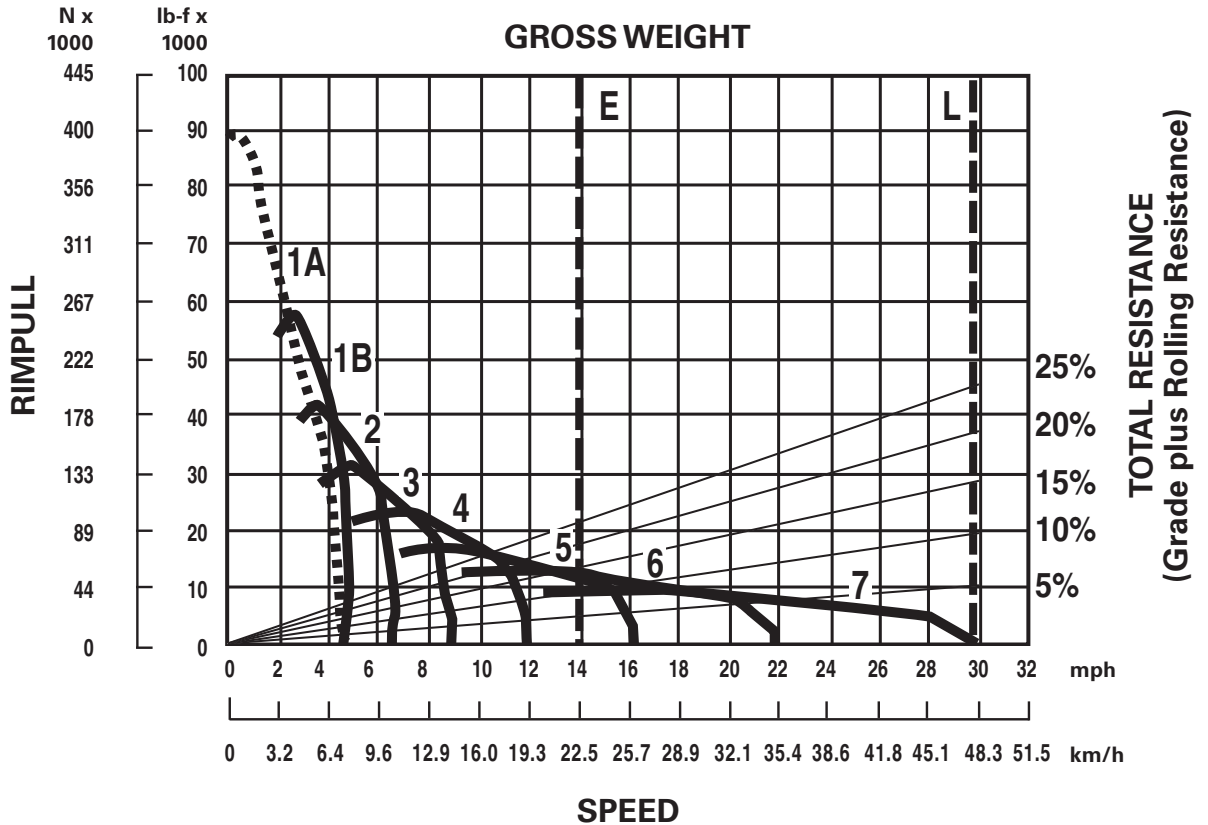

KEY

- 1A — 1st Gear Torque Converter Drive
- 1B — 1st Gear Direct Drive
- 2 — 2nd Gear Direct Drive
- 3 — 3rd Gear Direct Drive
- 4 — 4th Gear Direct Drive
- 5 — 5th Gear Direct Drive
- 6 — 6th Gear Direct Drive
- 7 — 7th Gear Direct Drive

KEY

- E — Empty 40 000 kg (88,185 lb)
- L — Loaded 85 000 kg (187,393 lb)

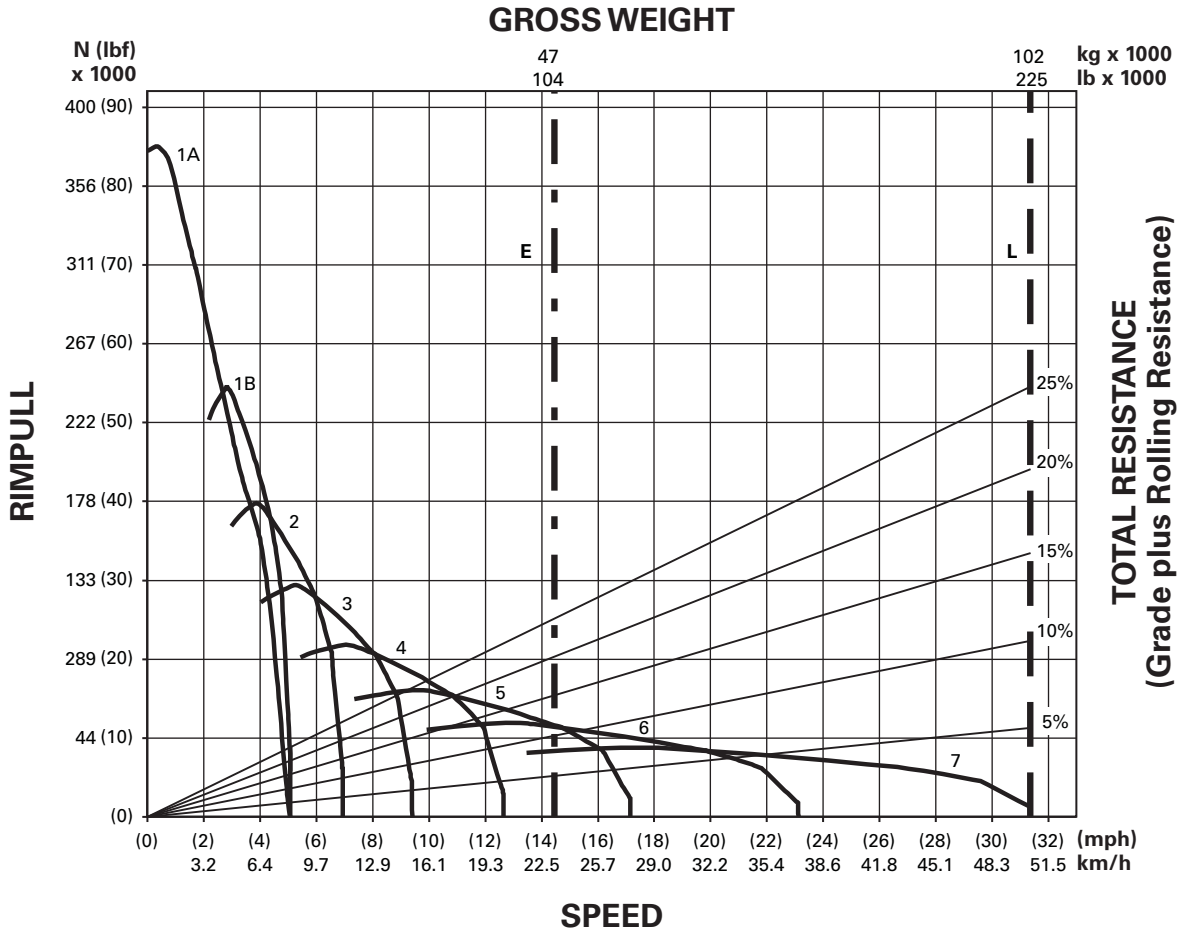

KEY

- 1A — 1st Gear Converter Drive
- 1B — 1st Gear
- 2 — 2nd Gear
- 3 — 3rd Gear
- 4 — 4th Gear
- 5 — 5th Gear
- 6 — 6th Gear
- 7 — 7th Gear

KEY

- E — Empty 47 000 kg (103,617 lb)
- L — Loaded 102 000 kg (224,871 lb)

Hard Rock

- Articulated Trucks
- AD60 Rimpull-Speed-Gradeability
- 35/65R33 Tires

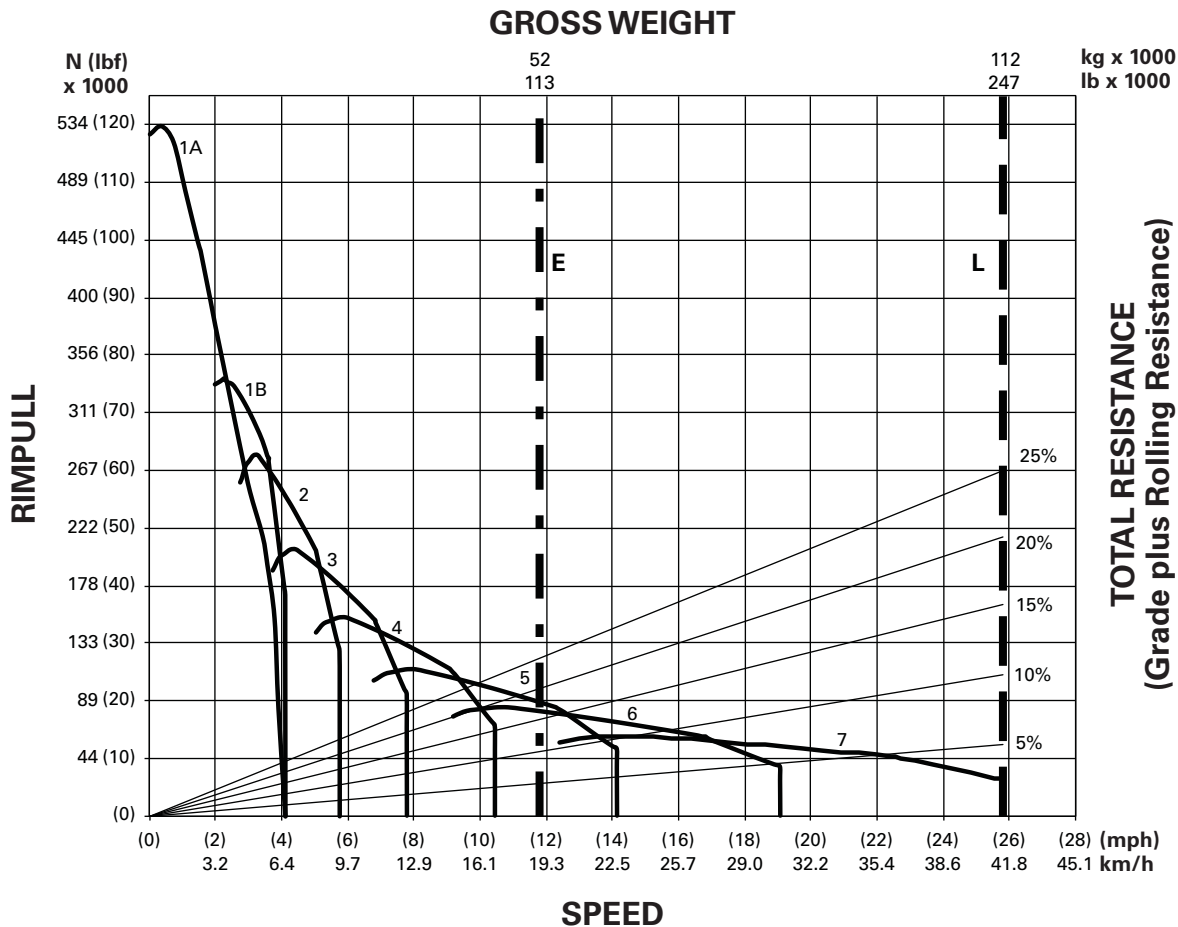

KEY

- 1A — 1st Gear (Converter Drive)
- 1B — 1st Gear
- 2 — 2nd Gear
- 3 — 3rd Gear
- 4 — 4th Gear
- 5 — 5th Gear
- 6 — 6th Gear
- 7 — 7th Gear

KEY

- E — Empty 51 200 kg (112,876 lb)
- L — Loaded 112 000 kg (246,917 lb)

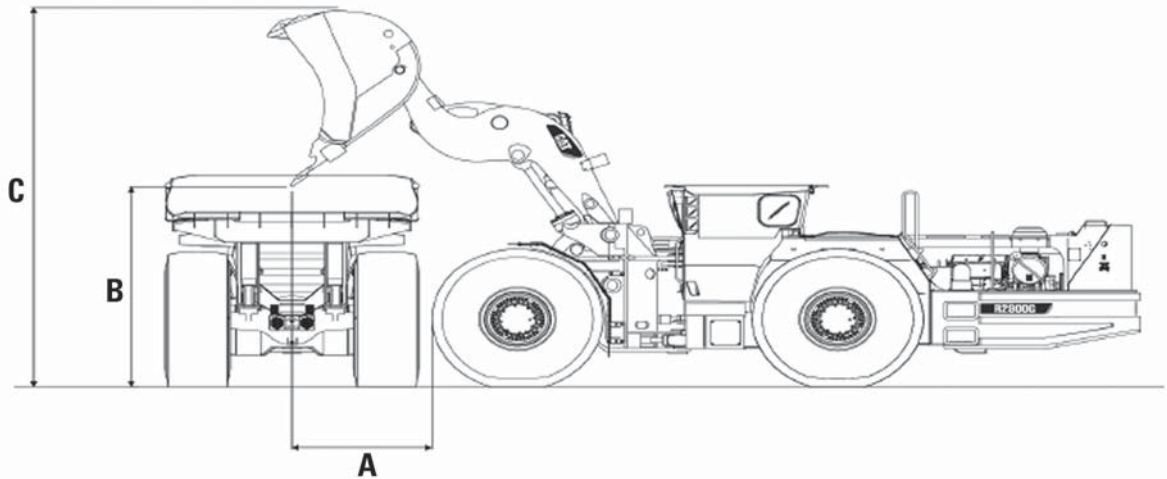

Loader	Target	A		B		C	
R1300G	AD30	1583 mm	62"	1560 mm	61"	3531 mm	139"
R1600H	AD30	1408 mm	55"	2207 mm	87"	4497 mm	177"
R1600H	AD45B	1408 mm	55"	2207 mm	87"	4497 mm	177"
R1700G	AD30	1738 mm	68"	2443 mm	96"	4884 mm	192"
R1700G	AD45B	1741 mm	68"	2443 mm	96"	4884 mm	192"
R1700G	AD55	1785 mm	70"	2443 mm	96"	4884 mm	192"
R2900G	AD45B	1656 mm	65"	2868 mm	113"	6179 mm	243"
R2900G	AD55	1656 mm	65"	2868 mm	113"	6179 mm	243"
R2900G	AD60	1656 mm	65"	2868 mm	113"	6179 mm	243"
R3000H	AD45B	1789 mm	70"	2868 mm	113"	5429 mm	213"
R3000H	AD55	1789 mm	70"	2744 mm	108"	5429 mm	213"
R3000H	AD60	1789 mm	70"	2744 mm	108"	5429 mm	213"

NOTE: R1700G rated payload 14 000 kg (30,870 lb) is for tramming only. Truck loading capacity is 12 500 kg (27,563 lb).

- Introduction
- Features

ROCK FLOW SYSTEM

Introduction

The innovative Cat Rock Flow System is a continuous production system for block caving operations. This special mining system combines the usage of a Rock Feeder, a Rock Mover and an automation system to deliver mass mining production with improved safety and sustainability.



The Rock Feeder RF300 extracts ore from the draw-point onto a Rock Mover [Hard Rock Chain Conveyor] by a hydraulically operated push plate.

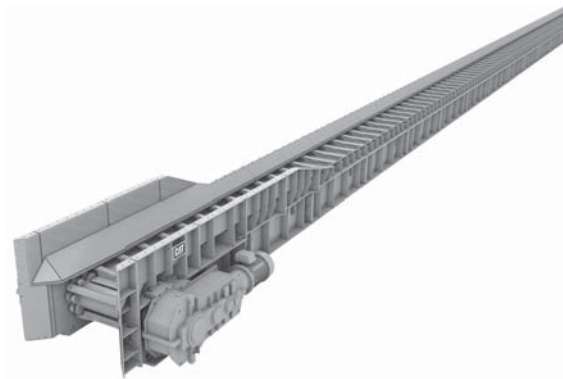

The Rock Mover RM900 is a dedicated hard rock production conveyor that collects ore from various draw-points. The Rock Flow Automation System (featuring remote operation from surface) allows draw and quality control and records operational data.

Features

- Continuous mass mining production system increases productivity.
- Highly automated system providing real time draw control.
- Easy maintenance and clearance work.
- Use of electric drives increases safety, reduces cost and improves underground climate and carbon footprint.

Rock Feeder	RF300	
Performance	300 tonnes/hr	331 tons/hr
Dimensions (L x W x H)	4300 mm x 2000 mm x 1050 mm	14.1' x 6.6' x 3.4'
Weight — Total RF300	22.0 tonnes	24.3 tons
Dozer Plate Cylinder:		
Quantity	4	
Stroke	1350 mm	4.4'
Cycle Time		120 Sec.
Pressure — Total	4021 kN	903,956 lbf
Pushing Cylinders:		
Quantity	2	
Stroke	600 mm	2'0"
Pressure — Total	5147 kN	1,157,092 lbf
Weight — Pushing Device	5.8 tonnes	6.4 tons

Rock Mover	RM900	
Performance	900 tonnes/hr	992 tons/hr
Chain Speed	0.15 m/sec	29.5 ft/min
Drive Power	2 x 75 kW	2 x 102 hp
Pan Width	1800 mm	5.9'
Pan Length	3000 mm	9.8'
Conveyor Length	77 m	252'0"
Chain Size	42 mm x 146 mm	1.65" x 5.75"
Hydraulic Return Unit:		
Option 1:	Manually adjustable unpowered	
Option 2:	Fully activated	

LONGWALL
Roof-Supports
AFC Systems
Beam Stage Loaders (BSL)
CST Drive Systems
Variable Frequency Drives
Shearers
Automated Plow Systems
Programmable Mining Controls
Roof Support Carriers
Shield Trailers

CONTENTS

LONGWALL

Introduction 20-26

Roof Supports:

 Features 20-26

 Specifications 20-27

 Special Applications 20-28

AFC Systems:

 Features 20-29

 Specifications 20-30

 Dimensions 20-34

 Conveying Performance 20-39

Beam Stage Loaders (BSL):

 Features 20-42

 Specifications 20-42

CST Drive Systems:

 Features 20-45

 Specifications 20-46

 Rated Power P/Gearbox Ratio i [-] 20-52

Variable Frequency Drives (VFD):

 Features 20-54

 Specifications 20-55

 Dimensions 20-56

Shearers:

 Features 20-57

 Specifications 20-58

 Dimensions 20-65

 Optional Accessories 20-75

Automated Plow Systems:

 Features 20-76

 Specifications 20-77

 Dimensions 20-79

Programmable Mining Controls:

 PMC-R:

 Features 20-97

 Specifications 20-97

 PMC-D and PMC-V:

 Features 20-101

 Specifications 20-101

 MCU2:

 Features 20-105

 Specifications 20-105

Roof Support Carriers:

 Features 20-107

 Specifications 20-108

 Dimensions 20-110

 Tractive Effort vs. Speed — Loaded 20-112

 % Grade vs. Speed — Loaded 20-113

 Lift Capability 20-114

Shield Trailers:

 Features 20-115

 Specifications 20-116

 Dimensions 20-117

 SH150 Load Setting Table 20-118

INTRODUCTION

Caterpillar is the global market leader and supplier of complete longwall systems. All over the world, our equipment and systems are meeting the demands of underground mining under the most stringent conditions. Adapted to the mining challenges faced by our customers today, Cat customized systems range from hydraulic roof supports, automated plow systems, shearers, face conveyors and drive systems to automation and roof support carriers. Caterpillar delivers your system of choice, from low to high seam heights, for the longest longwalls and highest production demands.

ROOF SUPPORTS

Features



Equipment You Can Rely On

- Availability typically 98% on average.
- Extensive tests on all structural, hydraulic and control components.
- Sophisticated PMC-R electro-hydraulic controls for full face automation.
- Down to 4-second advance cycles thanks to powerful hydraulics.
- Shield design in 3D, FEM integrated.

Customized Design

- Seamless range for mining heights from 0.55 to 7.5 m (1.8 to 24.6 ft) with support capacities of up to 1750 metric tonnes (1929 tons).
- Advanced design of critical parts prevents major failures, costly underground repairs and unscheduled downtime.
- Easy maintenance, long intervals between overhaul and very long service life.

Cat Roof Supports

Height Closed	500-2900 mm	19.7-114.2"
Height Extended	1100-6100 mm	43.3-240.2"
Shield Centers	1500-2050 mm	59-80.7"
Nominal Leg Forces	2 x 800-2 x 7156 kN	2 x 90-2 x 805 ton
Shield Density	Up to 111 tonne/m ²	Up to 12.5 ton/ft ²
Hydraulic Leg	Up to 500 mm	Up to 19.7"
Canopy	Rigid design (with telescopic flipper)	
Canopy Length	2997-8000 mm	118-315"
Forepole Length	1980-4520 mm	78-178"
Rear Projection	850-1448 mm	33.5-57"
Base	Split design OR rigid design with telescopic relay bar/pusher cylinder	
Relay Bar		
Direct Mounted OR Reverse Mounted	650-1067 mm effective web	25.6-39.4" effective web
Shifting Cylinder (with Reedrod)	700-1080 mm	27.6-42.5"
Shield Pull Force	185-565 kN/ 315/320/350 bar	20.7-63.3 ton/ 4568/4640/5076 psi
Conveyor Push Force	89-815 kN/ 315/320/350 bar	10.0-91.5 ton/ 4568/4640/5076 psi
Side Seals-on Canopy, Caving Shield (and rear lemniscates):		
Both Sides Fixed/One Side Fixed, One Side Movable, Rehandable/Not Rehandable	Up to 300 mm stroke	Up to 11.8" stroke
Materials	High strength steel	
Test	EN 1804, different test program with up to 90,000 cycles	
Weight	6.5-63.5 tonne	7.15-70 ton

Roof Support Specifications

Example High Seam Roof Support

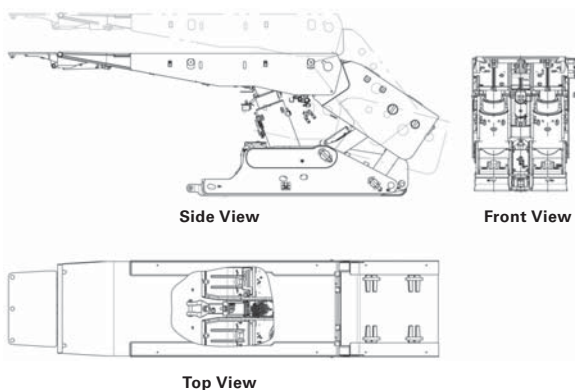

Example Low Seam Roof Support

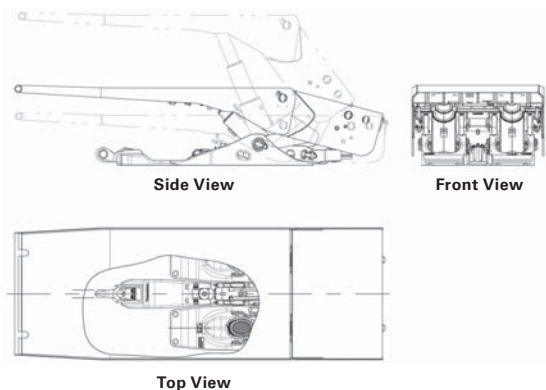

Special Applications

Specifically designed roof supports are available for the following mining applications:

- Steep-seam Mining

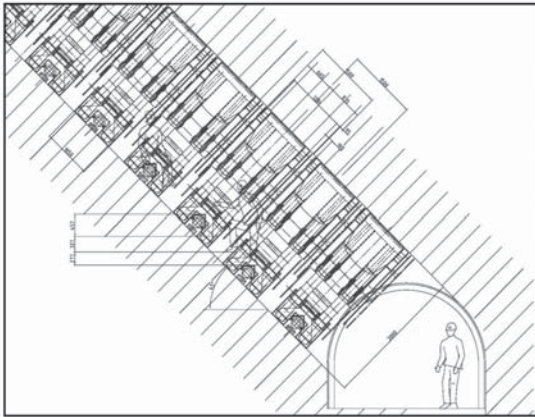

- Conventional Sublevel Caving

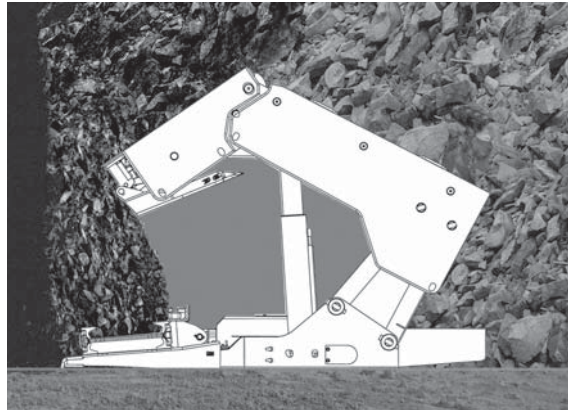

- Longwall Top Coal Caving (LTCC)

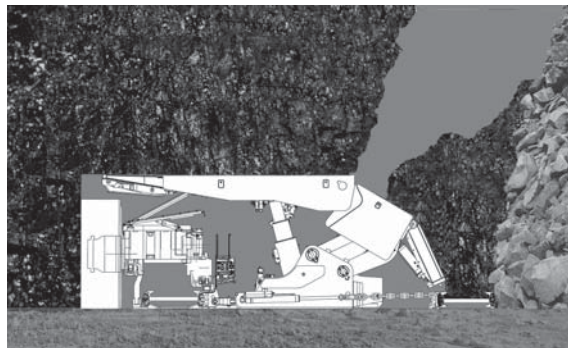

AFC SYSTEMS

Features



Moving Mountains

- For use in longwalls of up to 500 m (1640 ft) long.
- Up to 3×1800 kW (3×2413 hp) installed power.
- Capacities of up to 6200 tonnes/hr (6834 tons/hr).
- Intelligent CST drive system available.
- High system availability, long service life, low operating costs.
- Various shearer haulage systems with rack bar or chain.
- Main drive: Cross-frame, side discharge, overhead discharge.
- Rigid or automated tensionable tail drive.

AFC Line Pan Specifications – PF3

Model	PF3/722		PF3/822		PF3/922	
Line Pan Width	722 mm	28.42"	822 mm	32.36"	922 mm	36.30"
Flightbar Width	582 mm	22.91"	682 mm	26.85"	782 mm	30.78"
Deck Plate Thickness	30 mm	1.18"	30 mm	1.18"	30 mm	1.18"
Profile Height	244 mm	9.60"	244 mm	9.60"	244 mm	9.60"
Bottom Plate Thickness	20 mm	0.78"	20 mm	0.78"	20 mm	0.78"
Dogbone Breaking Strength	2000 kN	224.80 tonf	2000 kN	224.80 tonf	2000 kN	224.80 tonf
Dogbone Housing FoS	1.5 times		1.5 times		1.5 times	
Shear Strength	3000 kN	337.21 tonf	3000 kN	337.21 tonf	3000 kN	337.21 tonf
Vertical Articulation	Up to ± 6°		Up to ± 6°		Up to ± 6°	
Horizontal Articulation	0.8°-1.2°		0.8°-1.2°		0.8°-1.2°	
Chain Strands	DKB 26×29 DKB 30×108 DKB 34×126 DKB 38×137		DKB 26×29 DKB 30×108 DKB 34×126 DKB 38×137		DKB 26×29 DKB 30×108 DKB 34×126 DKB 38×137	
Conveying Capacity	0.18 m ²	1.93 ft²	0.26 m ²	2.80 ft²	0.36 m ²	3.87 ft²

AFC Line Pan Specifications – PF4

Model	PF4/832		PF4/932		PF4/1032	
Line Pan Width	832 mm	52.44"	932 mm	36.69"	1032 mm	40.62"
Flightbar Width	688 mm	46.77"	788 mm	31.02"	888 mm	34.96"
Deck Plate Thickness	40 mm	1.57"	40 mm	1.57"	40 mm	1.57"
Profile Height	284 mm	11.18"	284 mm	11.18"	284 mm	11.18"
Bottom Plate Thickness	25 mm	0.98"	25 mm	0.98"	25 mm	0.98"
Dogbone Breaking Strength	3000- 3600 kN	337.21- 404.65 tonf	3000- 3600 kN	337.21- 404.65 tonf	3000- 3600 kN	337.21- 404.65 tonf
Dogbone Housing FoS	1.5 times		1.5 times		1.5 times	
Shear Strength	4000 kN	449.61 tonf	4000 kN	449.61 tonf	4000 kN	449.61 tonf
Vertical Articulation	Up to ± 6°		Up to ± 6°		Up to ± 6°	
Horizontal Articulation	0.8°-1.2°		0.8°-1.2°		0.8°-1.2°	
Chain Strands	AKB FI30×108 DKB 34×126		AKB FI30×108 DKB 34×126		AKB FI30×108 DKB 34×126 DKB 42×146	
Conveying Capacity	0.26 m ²	2.80 ft²	0.36 m ²	3.87 ft²	0.46 m ²	4.95 ft²

AFC Line Pan Specifications – PF4 (continued)

Model	PF4/1132		PF4/1332	
Line Pan Width	1132 mm	44.65"	1332 mm	52.44"
Flightbar Width	988 mm	38.89"	1188 mm	46.77"
Deck Plate Thickness	40 mm	1.57"	40 mm	1.57"
Profile Height	284 mm	11.18"	284 mm	11.18"
Bottom Plate Thickness	25 mm	0.98"	25 mm	0.98"
Dogbone Breaking Strength	3000-3600 kN	337.21-404.65 tonf	3000-3600 kN	337.21-404.65 tonf
Dogbone Housing FoS	1.5 times		1.5 times	
Shear Strength	4000 kN	449.61 tonf	4000 kN	449.61 tonf
Vertical Articulation	Up to ± 6°		Up to ± 6°	
Horizontal Articulation	0.8°-1.2°		0.8°-1.2°	
Chain Strands	DKB 34×126 DKB 42×146 DKB 48×160/144		DKB 42×146 DKB 48×160/144	
Conveying Capacity	0.58 m ²	6.24 ft²	0.85 m ²	9.15 ft²

AFC Line Pan Specifications – PF5

Model	PF5/1142		PF5/1342	
Line Pan Width	1142 mm	44.96"	1342 mm	52.83"
Flightbar Width	988 mm	38.89"	1188 mm	46.77"
Deck Plate Thickness	50 mm	1.96"	50 mm	1.96"
Profile Height	318 mm	12.52"	318 mm	12.52"
Bottom Plate Thickness	30 mm	1.18"	30 mm	1.18"
Dogbone Breaking Strength	4500 kN	505.82 tonf	4500 kN	505.82 tonf
Dogbone Housing FoS	1.5 times		1.5 times	
Shear Strength	> 6000 kN	> 674.42 tonf	> 6000 kN	> 674.42 tonf
Vertical Articulation	Up to ± 6°		Up to ± 6°	
Horizontal Articulation	0.8°-1.2°		0.8°-1.2°	
Chain Strands	DKB 42×146 DKB 48×160/144		DKB 42×146 DKB 48×160/144	
Conveying Capacity	0.58 m ²	6.24 ft²	0.85 m ²	9.15 ft²

AFC Line Pan Specifications – PF6

Model	PF6/1042		PF6/1142	
Line Pan Width	1042 mm	41.02"	1142 mm	44.96"
Flightbar Width	888 mm	34.96"	988 mm	38.89"
Deck Plate Thickness	30 mm plus 25 mm	1.18" plus 0.98"	30 mm plus 25 mm	1.18" plus 0.98"
Profile Height	350 mm	13.77"	350 mm	13.77"
Bottom Plate Thickness	30 mm	1.18"	30 mm	1.18"
Dogbone Breaking Strength	4500 kN	505.82 tonf	4500 kN	505.82 tonf
Dogbone Housing FoS	1.5 times		1.5 times	
Shear Strength	> 6000 kN	> 674.42 tonf	> 6000 kN	> 674.42 tonf
Vertical Articulation	Up to ± 6°		Up to ± 6°	
Horizontal Articulation	0.8°-1.2°		0.8°-1.2°	
Chain Strands	DKB 42×146 DKB 48×160/144		DKB 42×146 DKB 48×160/144	
Conveying Capacity	approx. 0.58 m ²	approx. 6.24 ft²	approx. 0.58 m ²	approx. 6.24 ft²

Model	PF6/1242		PF6/1342	
Line Pan Width	1242 mm	48.90"	1342 mm	52.83"
Flightbar Width	1088 mm	42.83"	1188 mm	46.77"
Deck Plate Thickness	30 mm plus 25 mm	1.18" plus 0.98"	30 mm plus 25 mm	1.18" plus 0.98"
Profile Height	350 mm	13.77"	350 mm	13.77"
Bottom Plate Thickness	30 mm	1.18"	30 mm	1.18"
Dogbone Breaking Strength	4500 kN	505.82 tonf	4500 kN	505.82 tonf
Dogbone Housing FoS	1.5 times		1.5 times	
Shear Strength	> 6000 kN	> 674.42 tonf	> 6000 kN	> 674.42 tonf
Vertical Articulation	Up to ± 6°		Up to ± 6°	
Horizontal Articulation	0.8°-1.2°		0.8°-1.2°	
Chain Strands	DKB 42×146 DKB 48×160/144		DKB 42×146 DKB 48×160/144	
Conveying Capacity	approx. 0.72 m ²	approx. 7.75 ft²	approx. 0.85 m ²	approx. 9.15 ft²

AFC Line Pan Specifications – PF7

Model	PF7/1542		
Line Pan Width	1542 mm		60.71"
Flightbar Width	1388 mm		54.65"
Deck Plate Thickness	30 mm plus 25 mm		1.18" plus 0.98"
Profile Height	350 mm		13.77"
Bottom Plate Thickness	30 mm		1.18"
Dogbone Breaking Strength	4500 kN		505.82 tonf
Dogbone Housing FoS		1.5 times	
Shear Strength	> 6000 kN		> 674.42 tonf
Vertical Articulation		Up to ± 6°	
Horizontal Articulation		0.8°-1.2°	
Chain Strands		DKB 60x135/181	
Conveying Capacity	approx. 1.15 m ²		approx. 12.38 ft²

AFC Line Pan Dimensions – PF3
 (All dimensions are approximate.)

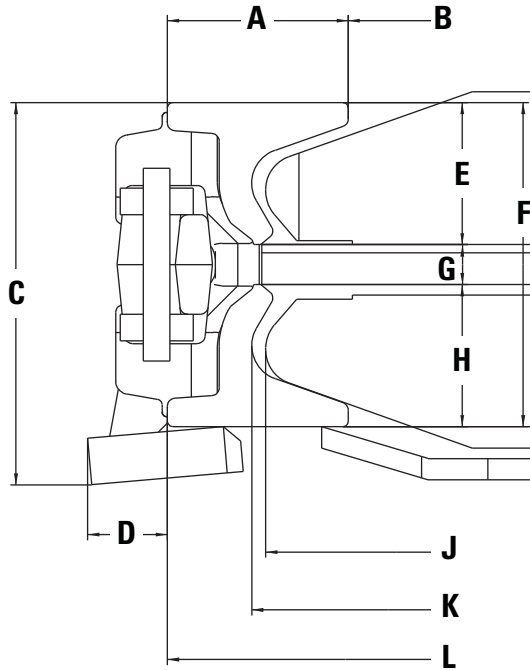

Model	PF3/722		PF3/822		PF3/922	
A	136 mm	5.35"	136 mm	5.35"	136 mm	5.35"
B	450 mm	17.72"	550 mm	21.65"	650 mm	25.59"
C	288 mm	11.33"	288 mm	11.33"	288 mm	11.33"
D	60 mm	2.36"	60 mm	2.36"	60 mm	2.36"
E	107 mm	4.21"	107 mm	4.21"	107 mm	4.21"
F	244 mm	9.6"	244 mm	9.6"	244 mm	9.6"
G	30 mm	1.18"	30 mm	1.18"	30 mm	1.18"
H	107 mm	4.21"	107 mm	4.21"	107 mm	4.21"
J	582 mm	22.91"	682 mm	26.85"	782 mm	30.78"
K	594 mm	23.38"	694 mm	27.32"	794 mm	31.26"
L	722 mm	28.42"	822 mm	32.36"	922 mm	36.30"

AFC Line Pan Dimensions — PF4
(All dimensions are approximate.)

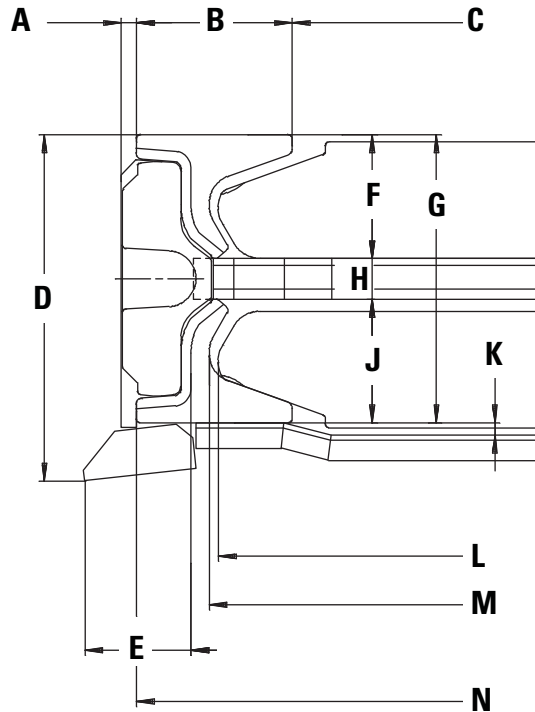

Model	PF4/832		PF4/932		PF4/1032		PF4/1132		PF4/1332	
A	15 mm	0.59"	15 mm	0.59"	15 mm	0.59"	15 mm	0.59"	15 mm	0.59"
B	154 mm	6.06"	154 mm	6.06"	154 mm	6.06"	154 mm	6.06"	154 mm	6.06"
C	524 mm	20.62"	624 mm	24.56"	724 mm	28.50"	824 mm	32.44"	1024 mm	40.31"
D	341 mm	13.42"	341 mm	13.42"	341 mm	13.42"	341 mm	13.42"	341 mm	13.42"
E	105 mm	4.13"	105 mm	4.13"	105 mm	4.13"	105 mm	4.13"	105 mm	4.13"
F	122 mm	4.80"	122 mm	4.80"	122 mm	4.80"	122 mm	4.80"	122 mm	4.80"
G	284 mm	11.18"	284 mm	11.18"	284 mm	11.18"	284 mm	11.18"	284 mm	11.18"
H	40 mm	1.57"	40 mm	1.57"	40 mm	1.57"	40 mm	1.57"	40 mm	1.57"
J	122 mm	4.80"	122 mm	4.80"	122 mm	4.80"	122 mm	4.80"	122 mm	4.80"
K	12 mm	0.47"	12 mm	0.47"	12 mm	0.47"	12 mm	0.47"	12 mm	0.47"
L	676 mm	26.61"	776 mm	30.55"	876 mm	34.48"	976 mm	38.42"	1176 mm	46.29"
M	688 mm	27.08"	788 mm	31.02"	888 mm	34.96"	988 mm	38.89"	1188 mm	46.77"
N	832 mm	32.75"	932 mm	36.69"	1032 mm	40.62"	1132 mm	44.56"	1332 mm	52.44"

AFC Line Pan Dimensions – PF5
 (All dimensions are approximate.)

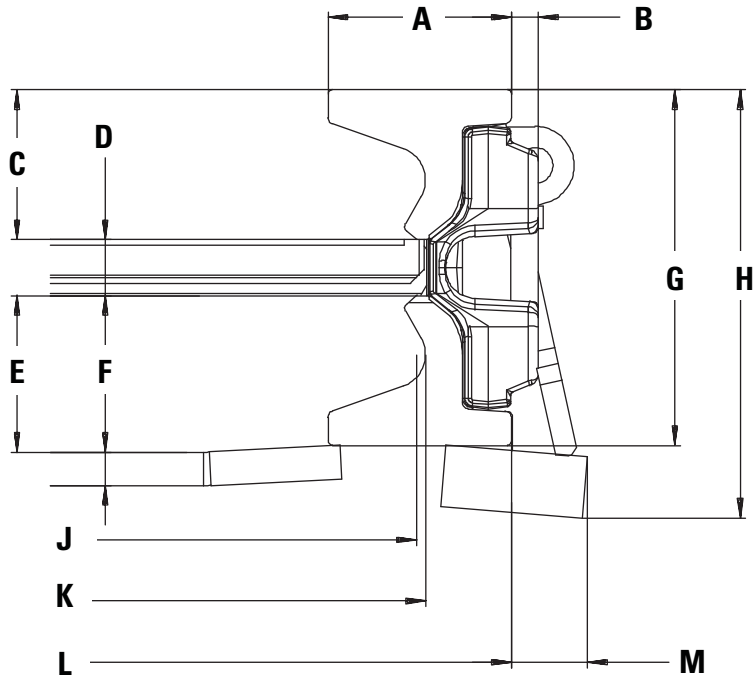

Model	PF5/1142		PF5/1342	
A	164 mm	6.45"	164 mm	6.45"
B	24 mm	0.94"	24 mm	0.94"
C	134 mm	5.27"	134 mm	5.27"
D	50 mm	1.96"	50 mm	1.96"
E	140 mm	5.51"	140 mm	5.51"
F	30 mm	1.18"	30 mm	1.18"
G	318 mm	12.52"	318 mm	12.52"
H	383 mm	15.07"	383 mm	15.07"
J	976 mm	38.42"	1176 mm	46.29"
K	988 mm	38.89"	1188 mm	46.77"
L	1142 mm	44.96"	1342 mm	52.83"
M	68 mm	2.67"	68 mm	2.67"

AFC Line Pan Dimensions – PF6
(All dimensions are approximate.)

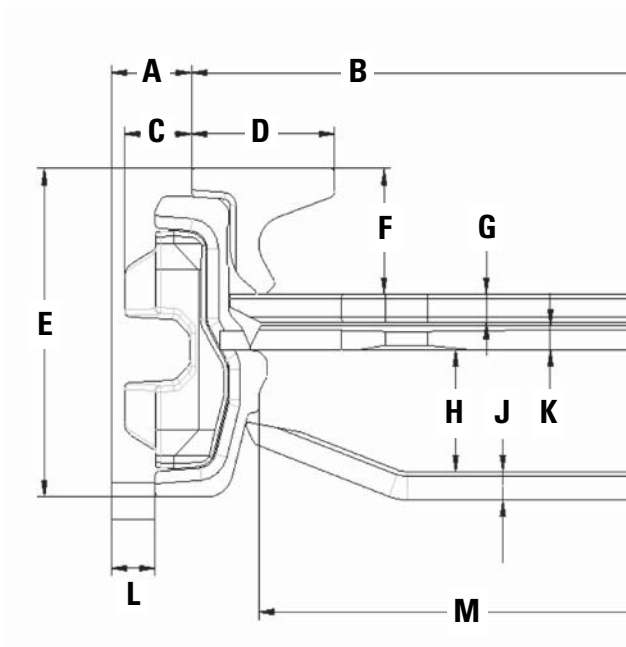

Model	PF6/1042		PF6/1142		PF6/1242		PF6/1342	
A	92 mm	3.62"	92 mm	3.62"	92 mm	3.62"	92 mm	3.62"
B	1042 mm	41.02"	1142 mm	44.96"	1242 mm	48.90"	1342 mm	52.83"
C	77 mm	3.03"	77 mm	3.03"	77 mm	3.03"	77 mm	3.03"
D	164 mm	6.45"	164 mm	6.45"	164 mm	6.45"	164 mm	6.45"
E	350 mm	13.77"	350 mm	13.77"	350 mm	13.77"	350 mm	13.77"
F	134 mm	5.27"	134 mm	5.27"	134 mm	5.27"	134 mm	5.27"
G	30 mm	1.18"	30 mm	1.18"	30 mm	1.18"	30 mm	1.18"
H	130 mm	5.11"	130 mm	5.11"	130 mm	5.11"	130 mm	5.11"
J	30 mm	1.18"	30 mm	1.18"	30 mm	1.18"	30 mm	1.18"
K	25 mm	0.98"	25 mm	0.98"	25 mm	0.98"	25 mm	0.98"
L	50 mm	1.96"	50 mm	1.96"	50 mm	1.96"	50 mm	1.96"
M	888 mm	34.96"	988 mm	38.89"	1088 mm	42.83"	1188 mm	46.77"

AFC Line Pan Dimensions – PF7
 (All dimensions are approximate.)

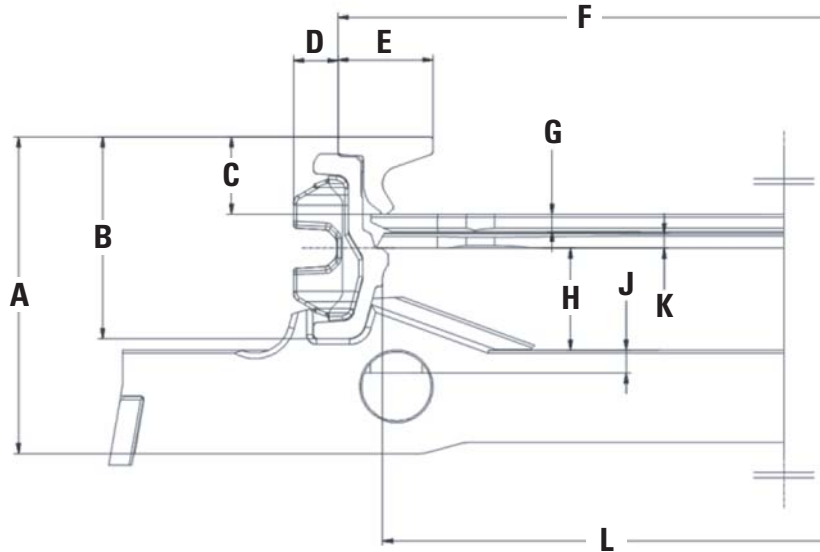

Model	PF7/1542	
A	550 mm	21.6"
B	350 mm	13.78"
C	134 mm	5.27"
D	77 mm	3.03"
E	164 mm	6.46"
F	1542 mm	60.71"
G	30 mm	1.18"
H	177 mm	6.97"
J	40 mm	1.57"
K	25 mm	0.98"
L	1388 mm	54.65"

AFC Line Pan Conveying Performance — PF3

PF3/722

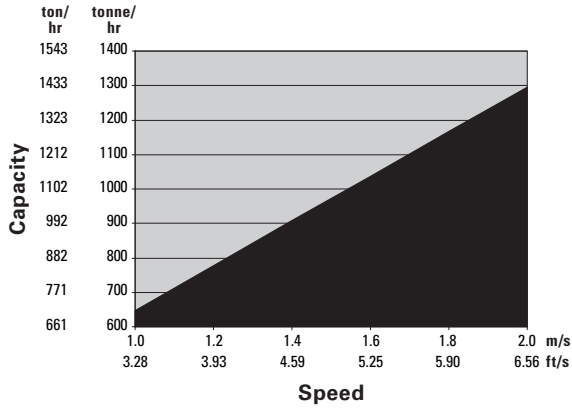

AFC Line Pan Conveying Performance — PF4

PF4/832

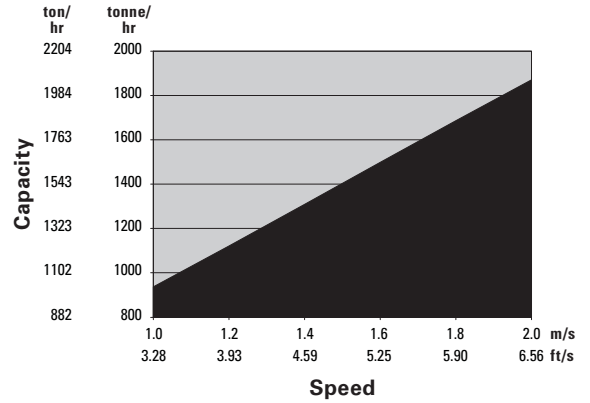

PF3/822

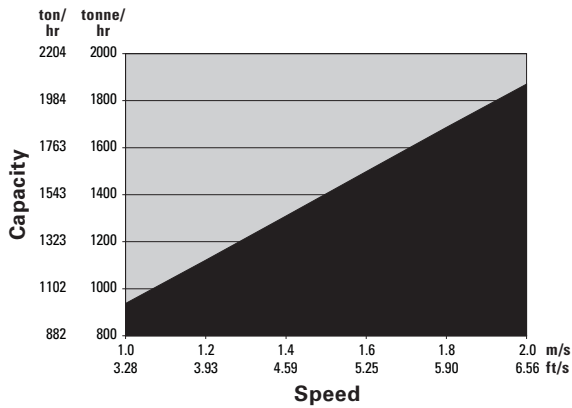

PF4/932

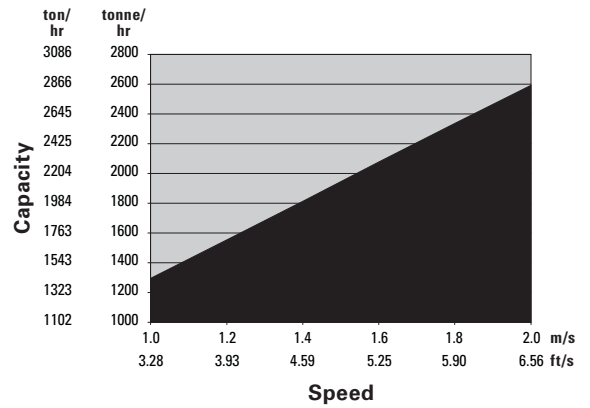

PF3/922

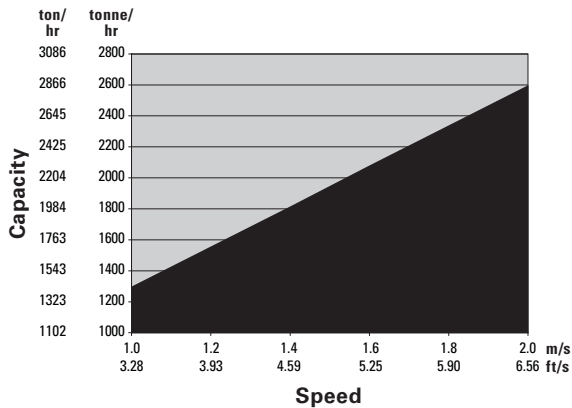

PF4/1032

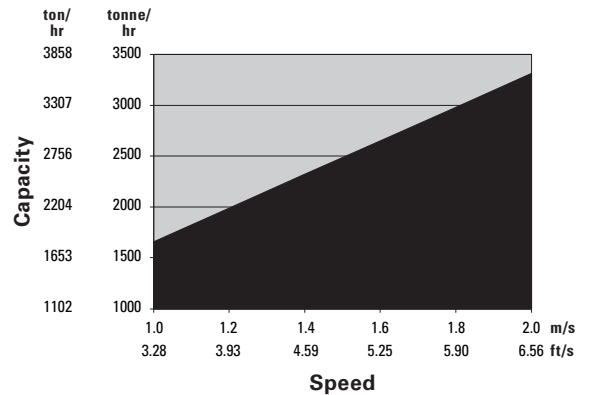

AFC Line Pan Conveying Performance — PF4

PF4/1132

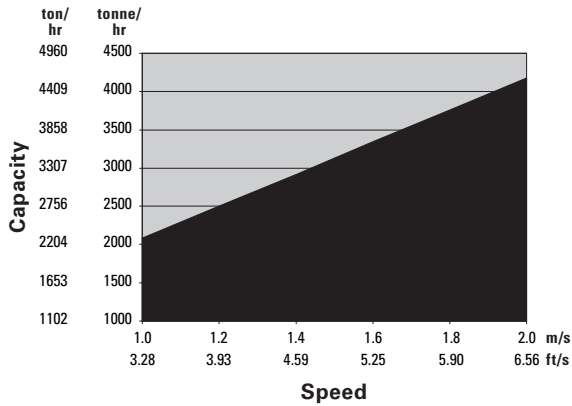

AFC Line Pan Conveying Performance — PF5

PF5/1142

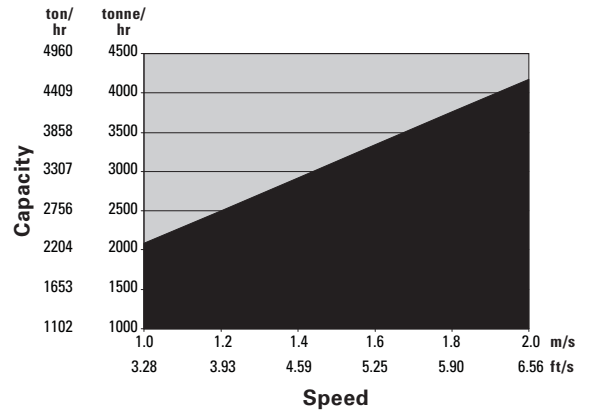

PF4/1332

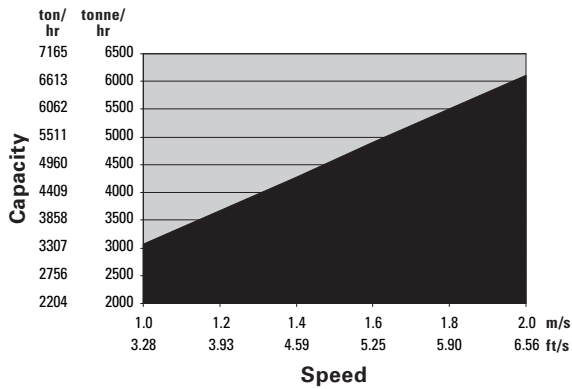

PF5/1342

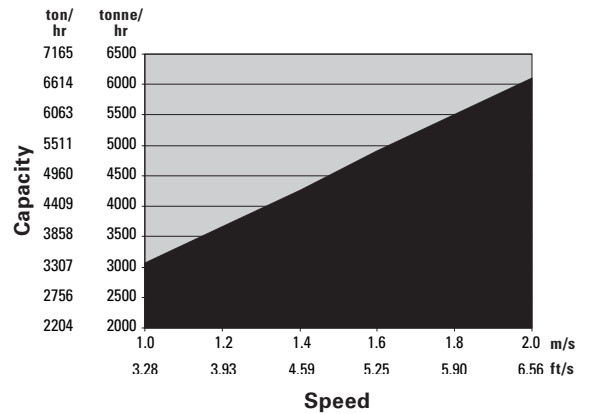

AFC Line Pan Conveying Performance — PF6

PF6/1042

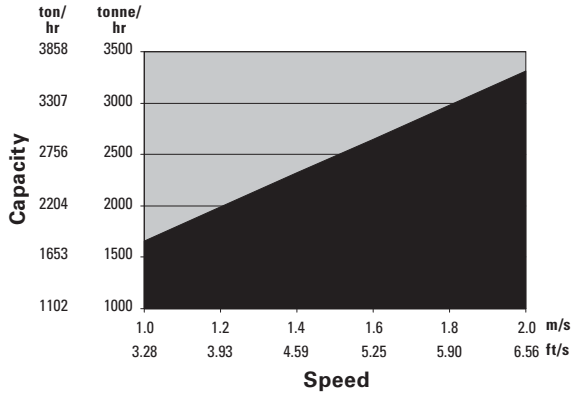

AFC Line Pan Conveying Performance — PF6

PF6/1342

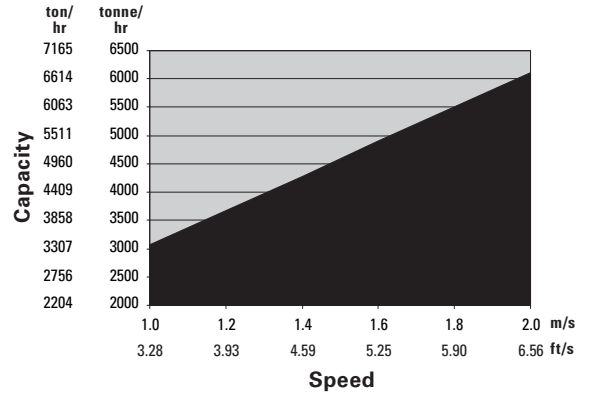

PF6/1142

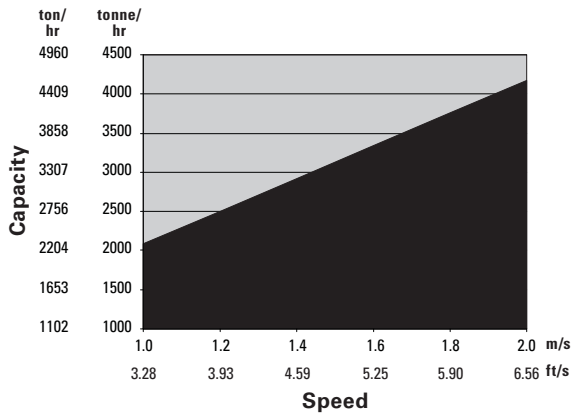

AFC Line Pan Conveying Performance — PF7

PF7/1542

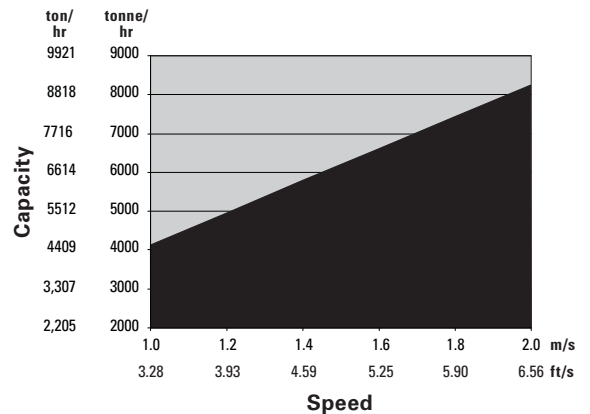

PF6/1242

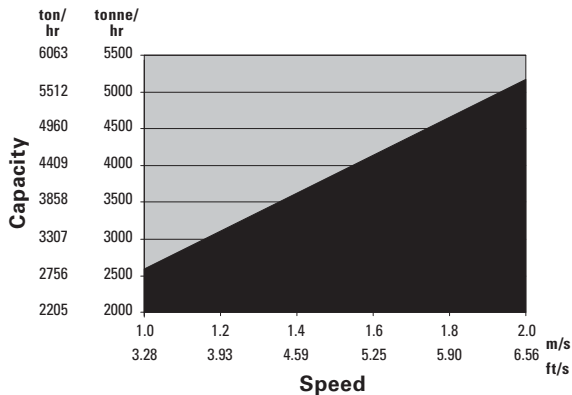

- Features
- Specifications

BEAM STAGE LOADERS (BSL)



The AFC is continuously running and conveys the coal mined by a shearer or plow to the head gate, where it is transferred onto the beam stage loader (BSL) with integrated crusher and then onto the main belt (eventually to the surface).

Main Functions of a BSL:

- Transportation of the coal from the AFC and hand-over to the belt conveyor.
- Crushing of coal blocks to smaller sizes to suit belt capability.

Features

- Stageloader and crusher completely matched to AFC, both with higher capacity to prevent bottlenecks.
- Tailor-made belt tailpiece for required capacity and belt dimensions, allowing BTP to handle longitudinal and lateral entry gradients.
- Horizontal crusher for high throughput and low operating costs due to double action impact elements.
- Automated chain tensioning system for enhanced chain and sprocket lifetime. As option SlackTronic available for superior chain tension management.
- Patented PowerChain technology available.

BSL Line Pan Specifications

Model	PF4		PF5		PF6	
Width Outside	932 mm	36.69"	1342 mm	52.83"	1342 mm	52.83"
	1132 mm	44.56"	1542 mm	60.71"	1542 mm	60.71"
	1332 mm	52.44"	1742 mm	68.58"	1742 mm	68.58"
Typical Top Plate Thickness	40 mm	1.57"	50 mm	1.97"	30 mm	1.18"
					(+ 25 mm)	(+ 0.98")
Bottom Plate Thickness	25 mm	0.98"	30 mm	1.18"	30 mm	1.18"
Dogbone Breaking Force	3600 kN	809,312 lbf	4500 kN	1,011,640 lbf	4500 kN	1,011,640 lbf
Production Average per Year	2000 tonnes	2204 tons	5500 tonnes	6063 tons	5500 tonnes	6063 tons
	3800 tonnes	4189 tons	6200 tonnes	6834 tons	6200 tonnes	6834 tons
	5500 tonnes	6063 tons	7000 tonnes	7716 tons	7000 tonnes	7716 tons

BSL Crusher — Impact Roll Crusher Specifications

Model	SK0909		SK1111		SK1118	
Feed Size	875 × 500 × X mm	34.4 × 19.7 × X"	1050 × 600 × X mm	41.3 × 23.6 × X"	1750 × 600 × X mm	68.9 × 23.6 × X"
Roll Diameter	910 mm	35.83"	1100 mm	43.31"	1100 mm	43.31"
Inlet Width	925 mm	36.42"	1100 mm	43.31"	1800 mm	70.87"
Maximum Passage Height	295 mm	11.61"	300 mm	11.81"	300 mm	11.81"
Type of Drive	Gearbox or V-Belt		Gearbox or V-Belt		Gearbox or V-Belt	
Maximum Installed Power V-Belt	132 kW	177 hp	315 kW	422 hp	500 kW	671 hp
Maximum Installed Power Gearbox	2 × 90 kW	2 × 121 hp	400 kW	536 hp	400 kW	536 hp
Throughput	1500 tonnes/hr	1653 tons/hr	3000 tonnes/hr	3307 tons/hr	5000 tonnes/hr	5511 tons/hr

Model	SK1218		SK1422	
Feed Size	1750 × 650 × X mm	68.9 × 25.6 × X"	2150 × 750 × X mm	84.6 × 29.5 × X"
Roll Diameter	1200 mm	47.24"	1400 mm	55.12"
Inlet Width	1800 mm	70.87"	2200 mm	86.61"
Maximum Passage Height	300 mm	11.81"	300 mm	11.81"
Type of Drive	Gearbox or V-Belt		Gearbox or V-Belt	
Maximum Installed Power V-Belt	750 kW	1006 hp	750 kW	1006 hp
Maximum Installed Power Gearbox	750 kW	1006 hp	750 kW	1006 hp
Throughput	6000 tonnes/hr	6614 tons/hr	8000 tonnes/hr	8818 tons/hr

Features

- Horizontal crushing.
- Exchangeable impact elements as standard.
- Hydraulic height adjustment of crusher roll to match output size to belt capability.
- PMC monitored overload protection causing BSL speed variation down to automatic stop.
- Spraying integrated into impact roll or spraying from the top cover for dust suppression available.
- Central lubrication system.

Tensionable Drive Frame Specifications

Model	SPR3		SPR5	
Available Widths	900 mm	35.43"	1100 mm	43.31"
	1100 mm	43.31"	1300 mm	51.18"
	1300 mm	51.18"	1500 mm	59.06"
	1500 mm	59.06"	1700 mm	66.93"
Sprocket	Universal Sprocket		Universal Sprocket	
Installed Power	Up to 400 kW	Up to 536 hp	Up to 500 kW	Up to 671 hp
Stroke	350 mm	13.78"	500 mm	19.68"
Capacity	Up to 6200 tonnes/hr	Up to 6834 tons/hr	Up to 7000 tonnes/hr	Up to 7716 tons/hr

BSL Gearbox Specifications

Model	K-10		KP-25/30	
Maximum Output Torque for Short Duration (3 sec.)	100 000 N·m	73,756 lb-ft	300 000 N·m	221,269 lb-ft
Maximum Input Speed (Motor Speed)	1800 RPM		1800 RPM	
Maximum Installed Power at:				
i = 39:1	160 kW*	262 hp**	435 kW*	709 hp**
i = 33:1	x	x	500 kW*	816 hp**
i = 28:1	200 kW*	326 hp**	500 kW*	816 hp**
i = 24,4:1	200 kW*	326 hp**	500 kW*	816 hp**
i = 21:1	200 kW*	326 hp**	500 kW*	816 hp**
i = 18:1	200 kW*	326 hp**	500 kW*	816 hp**
i = 16,94:1	200 kW*	326 hp**	—	—
i = 16:1	—	—	500 kW*	816 hp**
Input Shaft	D = 90		D=100 or W 100x4	
Output Shaft	W160/N190		N 220x10	
Required Cooling Water Flow	5 L/min	1.32 gal/min	15-20 L/min	3.96-5.28 gal/min
Cooling Water Inlet Temperature	25° C	77° C	25° C	77° C
Oil Filling Quantities	120 L	31 U.S. gal	137 L	36 U.S. gal
Weight (without oil)	1910 kg	4211 lb	3200 kg	7055 lb
Dimensions:				
Height	690 mm	27.16"	820 mm	32.28"
Length	1665 mm	65.55"	1419 mm	55.87"
Width	560 mm	22.05"	943 mm	37.13"

*Rated Power P [kW] (n = 1.485 RPM) (@ 50 Hz).

**Rated Power P [hp] (n = 1.782 RPM) (@ 60 Hz).

Boot End Specifications

Model	Skid-Mounted Boot End (SMB)		Crawler-Mounted Boot End (CMB)	
Belt Width	1000 mm	39.37"	1400 mm	55.12"
	1200 mm	47.24"		
	1400 mm	55.12"		
	1600 mm	62.99"		
Advancing Mechanism:				
Overlap	Up to 3500 mm	Up to 137.80"	Up to 3000 mm	Up to 118.11"
Recommendation	Normal Floor Conditions		Soft Floor	

CST DRIVE SYSTEMS

Features

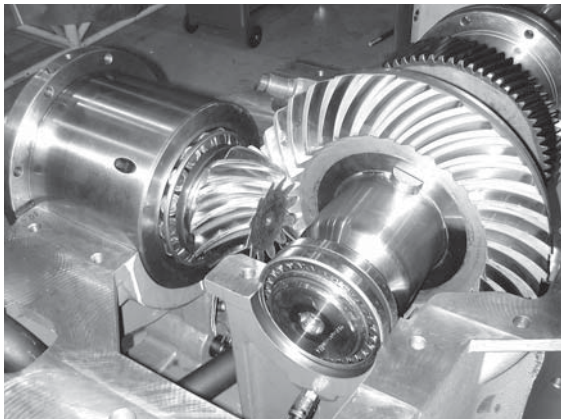
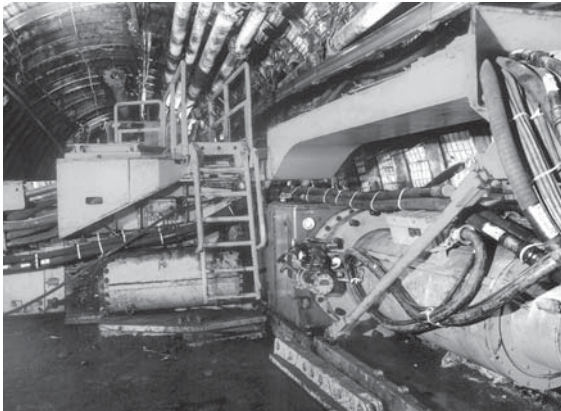

The Drive for Productivity

- No-load motor start-up with minimized energy demand on the electrical system.
- Soft start of the face conveyors which is gentle to all components, particularly the chain.
- Maximum total torque, available to facilitate heavy load start-up of the fully loaded conveyor.
- Accurate load sharing between the drives for full utilization of the installed power.
- Excellent overload protection in the event of sudden chain jams.
- Clutch delivers maximum efficiency with minimum operational slip of 0.2% with no wear.

Specifications

Model	CST30			
Typical Application	Chain Type Longwall Machinery like Armored Face Conveyors (AFC)			
	KP-30 CST		P-30 CST	
Maximum Output Torque (for 3 sec) T_{max} [N·m]	300 000 N·m	221,269 lb-ft	300 000 N·m	221,269 lb-ft
Ratio i [-]:	Rated Power P (n = 1485 RPM)	Rated Power P (n = 1782 RPM)	Rated Power P (n = 1485 RPM)	Rated Power P (n = 1782 RPM)
16	500 kW	816 hp	500 kW	816 hp
21	500 kW	816 hp	500 kW	816 hp
24.4	500 kW	816 hp	500 kW	816 hp
28	500 kW	816 hp	500 kW	816 hp
33	500 kW	816 hp	500 kW	816 hp
39	435 kW	710 hp	435 kW	710 hp
50	400 kW	653 hp	400 kW	653 hp
Dimensions:				
Length	2280 mm	89.8"	1400 mm	55.1"
Width	1180 mm	46.5"	960 mm	37.8"
Height	900 mm	35.4"	900 mm	35.4"
Capacity:				
Oil Quantity	500 L	132 U.S. gal	250 L	66 U.S. gal
Gearbox Weight (without oil)	5800 kg	12,783 lb	3900 kg	8596 lb
Requirements of Cooling Water:				
Required Cooling Water	20 L/min	5.28 gal/min	20 L/min	5.28 gal/min
Maximum Water Inlet Temperature	25° C/298,15 K	77° F/298.15 K	25° C/298,15 K	77° F/298.15 K
Shaft Design:				
Input Shaft (cylindrical)	DIN 5480-W 100×4×30×24		DIN 5480-W 100×4×30×24	
Output Shaft with Internal Toothing	DIN 5480-N 220×10×30×20		DIN 5480-N 220×10×30×20	

Specifications

Model	CST45			
Typical Application	Chain Type Longwall Machinery like Armored Face Conveyors (AFC)			
	KP-45 CST		P-45 CST	
Maximum Output Torque (for 3 sec) T_{max} [N·m]	450 000 N·m	331,858 lb-ft	450 000 N·m	331,858 lb-ft
Ratio i [-]:	Rated Power P (n = 1485 RPM)	Rated Power P (n = 1782 RPM)	Rated Power P (n = 1485 RPM)	Rated Power P (n = 1782 RPM)
24.5	800 kW	1305 hp	800 kW	1305 hp
28	800 kW	1305 hp	800 kW	1305 hp
33	800 kW	1305 hp	800 kW	1305 hp
39	700 kW	1142 hp	700 kW	1142 hp
45	540 kW	881 hp	540 kW	881 hp
50	500 kW	816 hp	500 kW	816 hp
Dimensions:				
Length	2875 mm	113.2"	1697 mm	66.8"
Width	1401 mm	55.2"	1120 mm	44.1"
Height	1060 mm	41.7"	1060 mm	41.7"
Capacity:				
Oil Quantity	730 L	193 U.S. gal	430 L	114 U.S. gal
Gearbox Weight (without oil)	9700 kg	21,385 lb	5900 kg	13,007 lb
Requirements of Cooling Water:				
Required Cooling Water	25 L/min	6.6 gal/min	25 L/min	6.6 gal/min
Maximum Water Inlet Temperature	25° C/298,15 K	77° F/298.15 K	25° C/298,15 K	77° F/298.15 K
Shaft Design:				
Input Shaft (cylindrical)	DIN 5480-W 120x4		DIN 5480-W 120x4	
Output Shaft with Internal Tothing	DIN 5480-N 260x10x30x24		DIN 5480-N 260x10x30x24	

Specifications

Model	CST45 M	
Typical Application	Chain Type Longwall Machinery like Armored Face Conveyors (AFC) and Plow Systems	
	P-45 M CST	
Maximum Output Torque (for 3 sec) T_{max} [N·m]	450 000 N·m	331,858 lb-ft
Ratio i [-]:	Rated Power P (n = 1485 RPM)	Rated Power P (n = 1782 RPM)
16	800 kW	1305 hp
21	800 kW	1305 hp
28	800 kW	1305 hp
33	800 kW	1305 hp
39	700 kW	1142 hp
45	540 kW	881 hp
50	500 kW	816 hp
Dimensions:		
Length	1697 mm	66.8"
Width	1120 mm	44.1"
Height	1060 mm	41.7"
Capacity:		
Oil Quantity	320 L	85 U.S. gal
Gearbox Weight (without oil)	7200 kg	15,873 lb
Requirements of Cooling Water:		
Required Cooling Water	30 L/min	7.9 gal/min
Maximum Water Inlet Temperature	25° C/298,15 K	77° F/298.15 K
Shaft Design:		
Input Shaft (cylindrical)	DIN 5480-W 120x4	
Output Shaft with Internal Toothing	DIN 5480-N 260x10x30x24	

Specifications

Model

CST45 V

Typical Application	Chain Type Longwall Machinery like Armored Face Conveyors (AFC)			
	KP-45 V CST		P-45 V CST	
	Rated Power P (n = 1485 RPM)	Rated Power P (n = 1782 RPM)	Rated Power P (n = 1485 RPM)	Rated Power P (n = 1782 RPM)
Maximum Output Torque (for 3 sec) T_{max} [N·m]	450 000 N·m	331,858 lb-ft	450 000 N·m	331,858 lb-ft
Ratio i [-]:				
16	1050 kW	1713 hp	1050 kW	1713 hp
21	1050 kW	1713 hp	1050 kW	1713 hp
28	1050 kW	1713 hp	1050 kW	1713 hp
33	1050 kW	1713 hp	1050 kW	1713 hp
39	820 kW	1338 hp	820 kW	1338 hp
45	710 kW	1158 hp	710 kW	1158 hp
50	650 kW	1061 hp	650 kW	1061 hp
Dimensions:				
Length	2875 mm	113.2"	1697 mm	66.8"
Width	1401 mm	55.2"	1120 mm	44.1"
Height	1060 mm	41.7"	1060 mm	41.7"
Capacity:				
Oil Quantity	730 L	193 U.S. gal	430 L	114 U.S. gal
Gearbox Weight (without oil)	9700 kg	21,380 lb	5900 kg	13,000 lb
Requirements of Cooling Water:				
Required Cooling Water	25 L/min	6.6 gal/min	25 L/min	6.6 gal/min
Maximum Water Inlet Temperature	25° C/298,15 K	77° F/298.15 K	25° C/298,15 K	77° F/298.15 K
Shaft Design:				
Input Shaft (cylindrical)	DIN 5480-W 120×4		DIN 5480-W 120×4	
Output Shaft with Internal Toothings	DIN 5480-N 260×10×30×24		DIN 5480-N 260×10×30×24	

Specifications

Model	CST65			
Typical Application	Chain Type Longwall Machinery like Armored Face Conveyors (AFC)			
	KP-65 CST		P-45 CST	
Maximum Output Torque (for 3 sec) T_{max} [N·m]	650 000 N·m	479,415 lb-ft	650 000 N·m	479,415 lb-ft
Ratio i [-]:	Rated Power P (n = 1480 RPM)	Rated Power P (n = 1800 RPM)	Rated Power P (n = 1480 RPM)	Rated Power P (n = 1800 RPM)
28	1200 kW	1958 hp	1200 kW	1958 hp
33	1200 kW	1958 hp	1200 kW	1958 hp
39	1000 kW	1632 hp	1000 kW	1632 hp
45	900 kW	1468 hp	900 kW	1468 hp
50	800 kW	1305 hp	800 kW	1305 hp
Dimensions:				
Length	2910 mm	114.6"	1887 mm	74.3"
Width	1530 mm	60.2"	1120 mm	44.1"
Height	1060 mm	41.7"	1060 mm	41.7"
Capacity:				
Oil Quantity	800 L	211 U.S. gal	500 L	132 U.S. gal
Gearbox Weight (without oil)	10 880 kg	23,980 lb	7300 kg	16,094 lb
Requirements of Cooling Water:				
Required Cooling Water	25 L/min	6.6 gal/min	25 L/min	6.6 gal/min
Maximum Water Inlet Temperature	25° C/298,15 K	77° F/298.15 K	25° C/298,15 K	77° F/298.15 K
Shaft Design:				
Input Shaft (cylindrical)	DIN 5480-W 120x4		DIN 5480-W 120x4	
Output Shaft with Internal Tothing	DIN 5480-N 320x10		DIN 5480-N 320x10	

Specifications

Model	CST115			
Typical Application	Chain Type Longwall Machinery like Armored Face Conveyors (AFC)			
	KP-115 CST		P-115 CST	
Maximum Output Torque (for 3 sec) T_{max} [N·m]	1 150 000 N·m	848,196 lb-ft	1 150 000 N·m	848,196 lb-ft
Ratio i [-]:	Rated Power P (n = 1485 RPM)	Rated Power P (n = 1782 RPM)	Rated Power P (n = 1485 RPM)	Rated Power P (n = 1782 RPM)
39	1800 kW	2937 hp	1800 kW	2937 hp
46	1800 kW	2480 hp	1800 kW	2480 hp
Dimensions:				
Length	3600 mm	141.6"	2811 mm	110.6"
Width	2029 mm	79.8"	1400 mm	55.1"
Height	1300 mm	51.1"	1300 mm	51.1"
Capacity:				
Oil Quantity	1300 L	212 U.S. gal	700 L	132 U.S. gal
Gearbox Weight (without oil)	23 980 kg	52,851 lb	16 400 kg	36,145 lb
Requirements of Cooling Water:				
Required Cooling Water	90 L/min	23.8 gal/min	90 L/min	23.8 gal/min
Maximum Water Inlet Temperature	25° C/298,15 K	77° F/298.15 K	25° C/298,15 K	77° F/298.15 K
Shaft Design:				
Input Shaft (cylindrical)	DIN 5480-W 140×4		DIN 5480-W 140×4	
Output Shaft with Internal Toothing	DIN 5480-N 360×10		DIN 5480-N 360×10	

Rated Power P/Gearbox Ratio i [-]

CST30

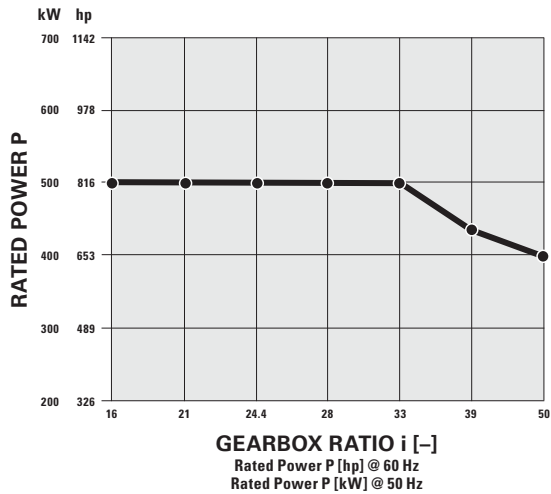

CST45 M

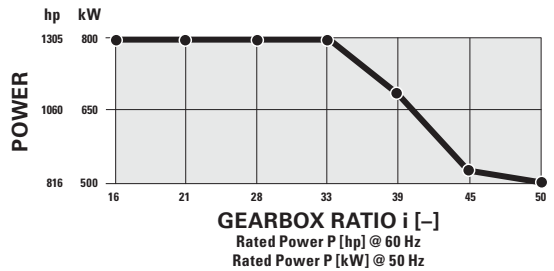

CST45

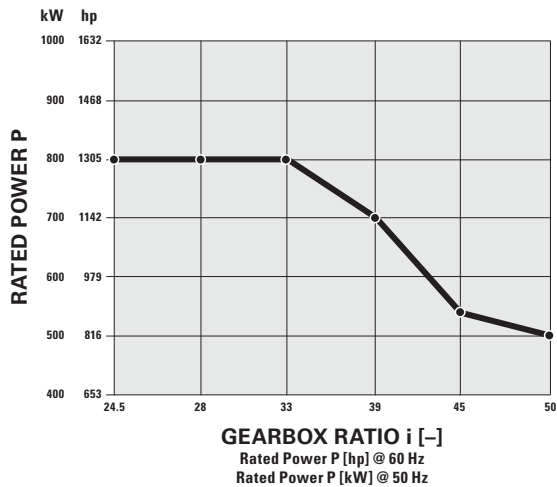

CST45 V

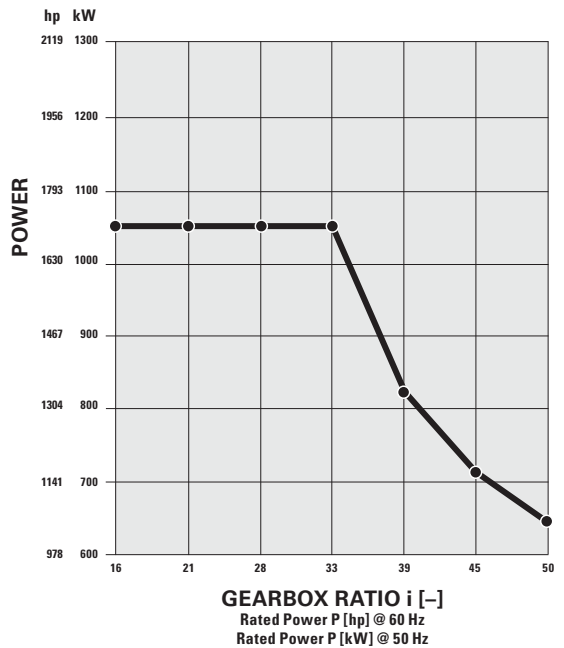

Rated Power P/Gearbox Ratio i [-]

CST65

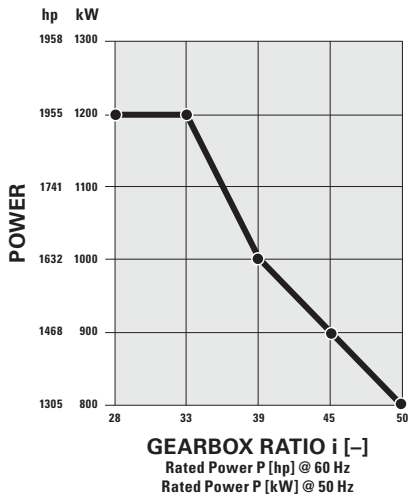

CST115

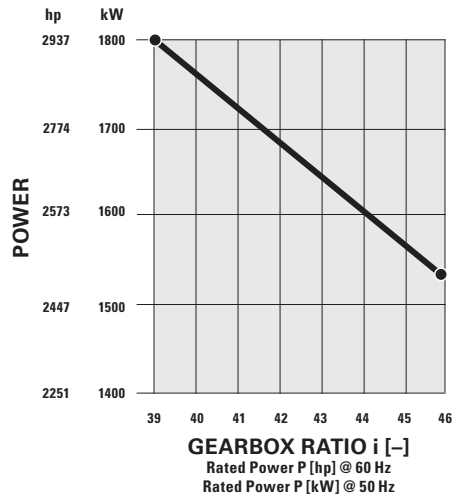

Variable Frequency Drives

Features

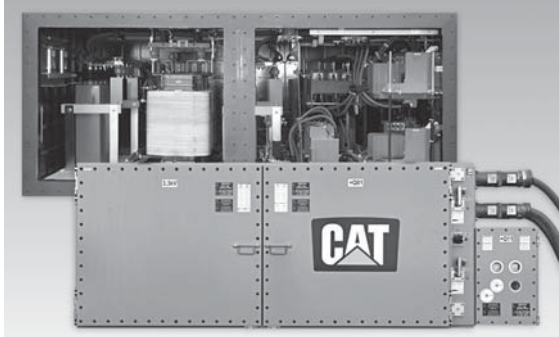

Air-Cooled VFD Container

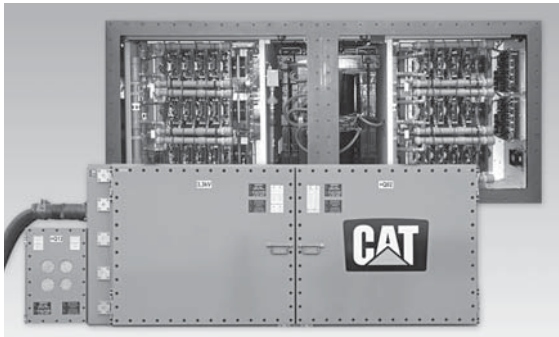

Liquid-Cooled VFD Container

The application of VFD brings a significant improvement for the plow and AFC operation. It implements among others the following advantages:

- **High Power System Stability/Quality**
 - Application of standard asynchronous motors.
 - Distance between motors and powering VFDs up to 4 kilometers (2.4 miles).
 - The usage of “weaker” networks is possible.
- **No EMC-Effects**
 - du/dt is small, no special requirements to motor’s insulate performance.
 - No overvoltages and reflection waves.
 - No high-frequency interference by pulsing circuit of IGBT.
 - No network perturbations by large harmonic wave components.
 - No parasitic ground currents.
- **Variability/Dynamic of the Drive System**
 - Variable speed for AFC and plow in a wide range (0 to 120% of nominal speed).
 - Greater dynamic of drive system.
 - Unlimited start-ups of the motors.
 - No significant voltage drop during start-ups.
 - Reduction of mechanical stress.
- **Synchronicity and Precision/Utilization of the Full Power**
 - High constant torque throughout the entire speed range from 0 to maximum speed.
 - Full utilization of installed power on both plow’s motors through load shearing.
 - Synchronized start-up of all drives at full load.
 - Controlled load distribution between all drives.
 - Torque control function makes motor work with constant torque.
 - External encoder interface for speed feedback.
 - Moment and speed parameterizable.
- **Low Life Cycle Costs**
 - Reduction of impact of drive system on chain, line pans and chain sprockets.
 - Quick torque and speed reduction in case of blockades or chain cracks.
 - Improvement of overload protection for motors and chains.
 - Detection of chain break through controlled shut down.
- **Energy Recovery**
 - Breaking possibilities and thus returning power back to the network.
- **Maximum Torque at Zero Speed**
 - Total torque control at zero speed.
 - Tension of the chain without a chain tensioning unit.
- **Monitoring System**
 - System parameter (voltage, power, torque, effective power, speed, etc.) are directly (online) available.
- **Optional Functions**
 - Evenly distributed load of conveyor by adjustment of speed depending on the direction of motion of the extraction machine (optional).
 - Adjustment of profit performance depending on capacity utilization of downstream systems (optional).

Specifications

Model	VFD — A800/W800		VFD — A1200/W1200	
Rated Power	800 kW	1072 hp	1200 kW	1609 hp
Input Voltage	3300 V ± 10%		3300 V ± 10%	
Output Voltage	0-3300 V		0-3300 V	
Input Frequency	50/60 Hz ± 5%		50/60 Hz ± 5%	
Output Frequency	0-60 Hz		0-60 Hz	
Power Factor (cos phi)	>97.5% (PWM)		>97.5% (PWM)	
Slew Rate	20%-80% <20 m/sec	20%-80% <65.62 ft/sec	20%-80% <20 m/sec	20%-80% <65.62 ft/sec
Maximum Operational Torque	210%		210%	
Operation	4Q		4Q	
Converter	Current Source Inverter (CSI)		Current Source Inverter (CSI)	
Motor Type	AC motor		AC motor	
Setup	VFD separate from motor		VFD separate from motor	

Current Source Converter

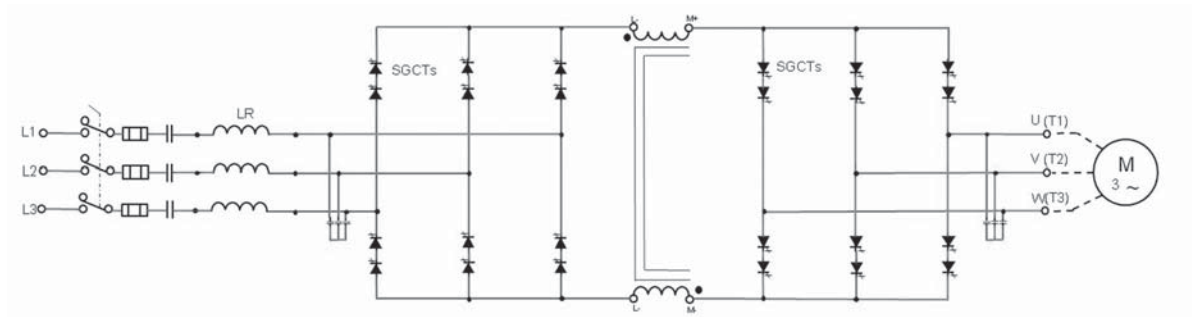

Dimensions (All dimensions and weights are approximate.)

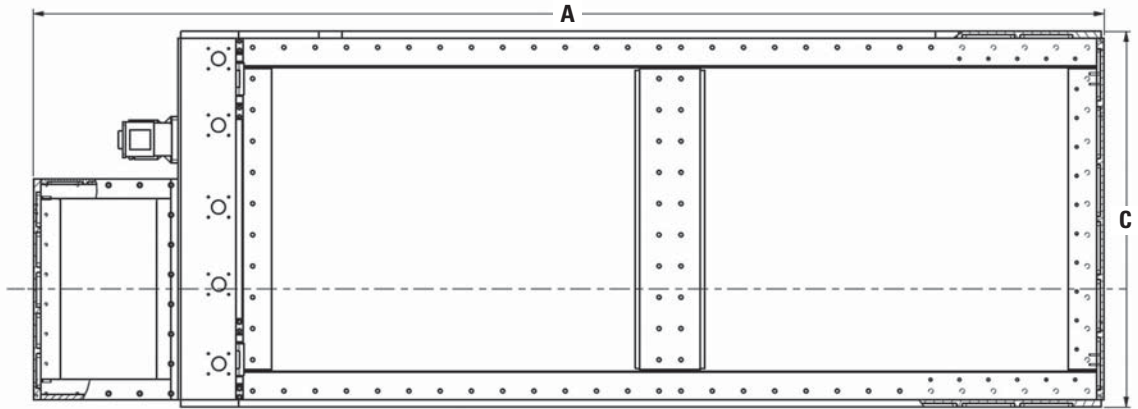

Side View

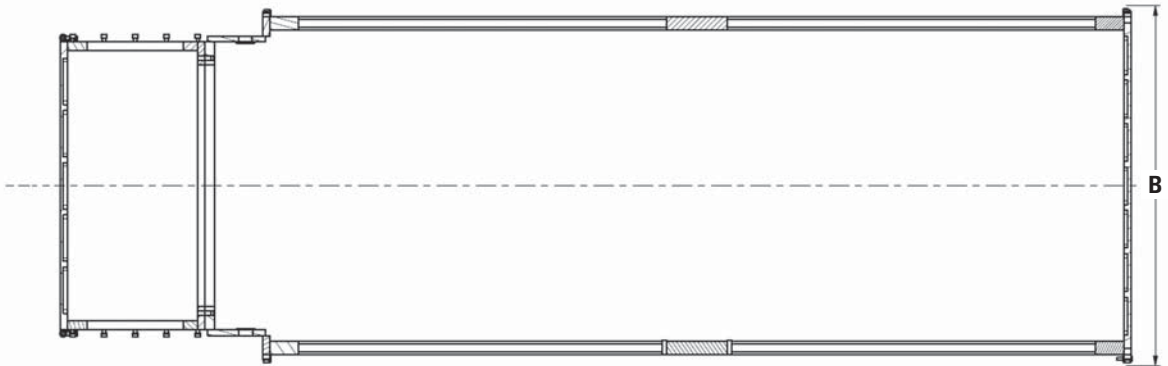

Top View

A Length	3700 mm	146"
B Width	1245 mm	49"
C Height	1300 mm	51"
Weight – VFD-A800 (air cooled)	6700 kg	14,771 lb
Weight – VFD-W800 (water cooled)	7800 kg	17,196 lb

Shearers

Features

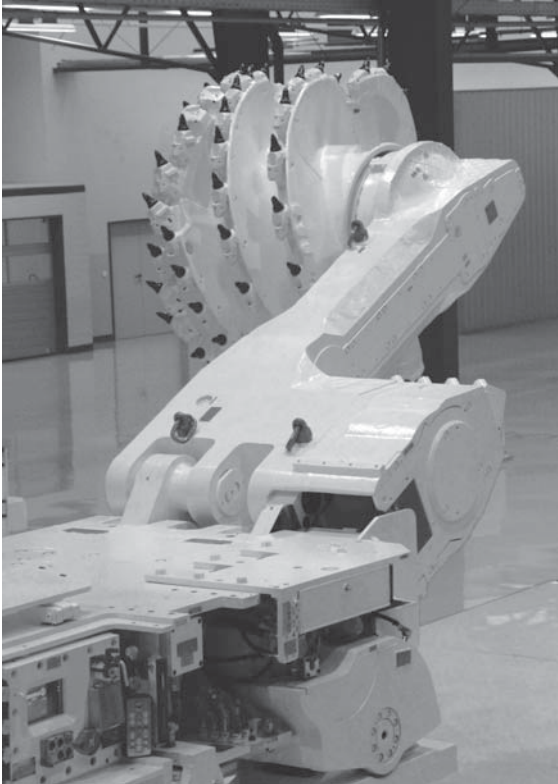

Taking the Shearer to the Next Level

- Cat shearers meet the demands of the world's leading longwall operators in medium to high seam mining.
- Highest reliability due to own test center.
- Power for the toughest mining conditions.
- Robust design and unique mainframe concept.
- Unparalleled control with world-leading automation capabilities.
- Seam range: 1.8–7.0 m (5.9–23.0 ft).
- Installed power of up to 2295 kW (3078 hp), cutting speed up to 45 m/min (150 ft/min).
- Maximum capacity: 5000 tonnes/hr (6063 tons/hr).

Specialized Shearers

Caterpillar also supplies shearers for specialized applications:

- Single- and double-drum low-seam shearer.
- Three-drum shearer for selective mining.

These shearers utilize the key feature of modular mainframe construction and are proven for coal and non-coal applications.

Specifications

Model	EL2000		EL3000		EL4000	
	Machine @ 50 Hz	Machine @ 60 Hz	Machine @ 50 Hz	Machine @ 60 Hz	Machine @ 50 Hz	Machine @ 60 Hz
Seam Range	1.8-4.5 m	71-177"	2.5-5.5 m	98-217"	4.0-7.0 m	158-276"
Typical Machine Length (drum centers)	14 155 mm	46.2'	15 200 mm	49.9'	17 008 mm	55.8'
Installed Power	Up to 1780 kW	Up to 2387 hp	Up to 2295 kW	Up to 3680 hp	Up to 2295 kW	Up to 3680 hp
Available Cutting Power:	2 x 500 kW 2 x 620 kW 2 x 750 kW	2 x 800 hp 2 x 1000 hp 2 x 1200 hp			2 x 860 kW 2 x 750 kW	2 x 1380 hp 2 x 1200 hp
RA860 Arms			2 x 860 kW	2 x 1380 hp		
RA860 Arms			2 x 750 kW	2 x 1200 hp		
RA750 Arms			2 x 620 kW	2 x 1000 hp		
RA750 Arms			2 x 750 kW	2 x 1200 hp		
Cutting Drum Diameter:	1600-2500 mm	63-98.5"			Up to 3500 mm	Up to 138"
RA860			Up to 2750 mm	Up to 108"		
RA750			Up to 2500 mm	Up to 98"		
Cutting Drum Speed:	32.8, 37.4 and 45.2 RPM	39.4, 44.9 and 54.3 RPM			30.8, 35 and 43 RPM	37, 42 and 51.6 RPM
RA860			30.8, 35 and 43 RPM	37.42 and 51.6 RPM		
RA750			32.8, 37.4 and 45.2 RPM	39.4, 44.9 and 54.3 RPM		
Haulage System	AC Inverter Drive		AC Inverter Drive		AC Inverter Drive	
Haulage Motor	2 x 125 kW	2 x 168 hp	2 x 150 kW	2 x 240 hp	2 x 150 kW	2 x 240 hp
Haulage Speed	Up to 30.1 m/min	Up to 98.5 ft/min	Up to 31.1 m/min	Up to 98.7 ft/min	Up to 31.1 m/min	Up to 98.7 ft/min
Haulage Pull	Up to 945 kN	Up to 107 tons	Up to 1075 kN	Up to 123 tons	Up to 1075 kN	Up to 120 tons
Pump Motor	30 kW	40 hp	75 kW	120 hp	75 kW	120 hp
Body Height	600 mm	23.6"	685 mm	27"	1070 mm	42"
Machine Weight (approximate)	70 tonnes	77 tons	105 tonnes	116 tons	130 tonnes	143 tons
Operating Voltage	3300V	4160V	3300V	4160V	3300V	4160 V
Minimum Pan Width	1032 mm	40.6"	1132 mm	44.6"	1342 mm	52.8"
Coal Sizer		—	200 kW	320 hp	200 kW	320 hp

Ranging Arms

Two types of ranging arm, both designed and robustly tested, for longer service life.

	RA750	RA860
EL2000	●	
EL3000	●	●
EL4000		●

RA750

- Transmission rating of 750 kW @ 37.4 RPM and above
- Maximum drum diameter of 2500 mm (98 in)
- Choice of drum speeds
- Complete with 32 mm (1.3 in) bore, through shaft PFF/PBF wet cutting
- Square drum hub (440 mm [17.3 in] across flats)
- Maximum oil capacity of 28 L (7 gal) in high speed compartment and 30 L (8 gal) in the epicyclic
- Integral monitoring transducers
- Quillshaft transmission protection
- A robust cowl drive mechanism is also available on both models (EL2000, EL3000)
- Online vibration monitoring with VibraGuard
- Available cutting motors:
 - EL2000 500 kW, 620 kW and 750 kW @ 50 Hz (800 hp, 1000 hp and 1200 hp @ 60 Hz)
 - EL3000 620 kW and 750 kW @ 50 Hz (1000 hp and 1200 hp @ 60 Hz)

RA860

- Transmission rating of 860 kW @ 30.8 RPM and above
- Maximum drum diameter:
 - EL3000 2750 mm (108 in)
 - EL4000 3500 mm (138 in)
- Choice of drum speeds
- Complete with 32 mm (1.3 in) bore, through shaft PFF/PBF wet cutting
- Square drum hub (630 mm [24.8 in] across flats)
- Maximum oil capacity of 45 L (12 gal) in high speed compartment and 60 L (15.85 gal) in the epicyclic
- Integral monitoring transducers
- Quillshaft transmission protection
- A robust cowl drive mechanism is also available
- Online vibration monitoring with VibraGuard
- Available cutting motors — 750 kW and 860 kW @ 50 Hz (1200 hp and 1380 hp @ 60 Hz)

Haulage Units

	HU125	HU150
EL2000	●	
EL3000		●
EL4000		●

Haulage Unit — HU125

Total Machine Pull	945.51 kN 96.80 tonnes	212,559 lbf 106.70 tons
Speed at Maximum Pull	14.28 m/min	46.83 ft/min
Maximum Machine Speed	28.56 m/min	93.66 ft/min
Pull at Maximum Speed	472.75 kN 48.40 tonnes	106,278 lbf 53.35 tons

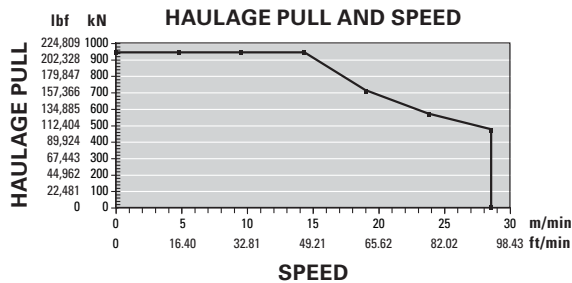

- Maximum power rating 125 kW (168 hp)
- Integral water cooling @ 9 L/min (2 gal/min)
- Transmission reduction of 137:1
- Maximum oil capacity of 25 L (7 gal)
- Integral monitoring transducers
- Quillshaft transmission protection
- This unit has a haulage motor rating of 125 kW (168 hp)
- Available with Machine Position Encoder
- Available with Machine Parking Brake

Haulage Unit — HU150

Total Machine Pull	1075.94 kN 110.15 tonnes	241,881 lbf 121.42 tons
Speed at Maximum Pull	15.06 m/min	49.39 ft/min
Maximum Machine Speed	30.11 m/min	98.77 ft/min
Pull at Maximum Speed	537.97 kN 55.07 tonnes	120,940 lbf 60.70 tons

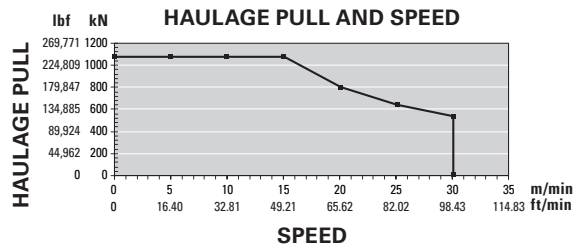

- Maximum power rating 150 kW (201 hp)
- Integral water cooling @ 9 L/min (2 gal/min)
- Transmission reduction of 137:1
- Maximum oil capacity of 25 L (7 gal)
- Integral monitoring transducers
- Quillshaft transmission protection
- This unit has a haulage motor rating of 150 kW (201 hp)
- Available with Machine Position Encoder
- Available with Machine Parking Brake
- Online vibration monitoring with VibraGuard

Down Drives

	DD125	DD150
EL2000	●	
EL3000		●
EL4000		●

Down Drive — DD125/DD150

- Innovative and unique downdrive design
- Transmission rating:
DD125 125 kW (168 hp)
DD150 150 kW (201 hp)
- Maximum haulage pull:
DD125 945 kN (107 tons)
DD150 1075 kN (123 tons)
- Fully removable, rehandable, modular gearbox
- Removable modular top drive wheel assembly (cartridge)
- Downdrive ratio:
DD125 17T-23T-10T (two wheel configuration)
EL3000:
DD150 22T-31T-11T (two wheel configuration);
available with three wheel configuration
(27T idler)
EL4000:
DD150 22T-27T-31T-11T (three wheel configuration)
- Trapping shoe with replaceable wear inserts, safe and easy replace (unique to Caterpillar)
- Suitable for all current track-type systems

Powerpack

	PP2	PP3
EL2000	●	
EL3000		●
EL4000		●

Powerpack — PP2/PP3

- Fixed displacement pump, with a capacity of:
PP2 50 L/min (13.21 gal/min)
PP3 200 L/min (53 gal/min)
- Operating system pressure:
PP2 260 bar (3770 psi)
PP3 210 bar (3046 psi)
- Robust hydraulic reservoir; capacity:
PP2 165 L (43.6 gal)
PP3 300 L (79 gal)
- Integral monitoring transducers
- For use with ISO 68 or ISO 100 hydraulic oils
- Available with 6 (PP2, PP3) or 8 (PP3) valve bank (dependent on function requirement)
- Available with two speed ranging arm facility (EL4000)
- This unit has a pump motor rating of:
PP2 30 kW @ 50 Hz (48 hp @ 60 Hz)
PP3 75 kW @ 50 Hz (120 hp @ 60 Hz)

Mainframe

	MF2	MF3	MF4
EL2000	●		
EL3000		●	
EL4000			●

Mainframe — MF2/MF3/MF4

- High structural integrity and absorption of all cutting and haulage forces, providing maximum protection of all major units
- Maximum protection of electrical boxes, providing the highest level of flameproof integrity
- Improved access for maintenance and ease of overhaul and repair
- Versatility of application due to fully modular construction
- A split mainframe is available in case of transportation limitations

Hydraulically Activated Top Guards

- EL3000 and EL4000 are equipped with hydraulically activated top guards

Electrical Control Box

	ECB2	ECB3
EL2000	●	
EL3000		●
EL4000		●

Electrical Control Box — MF2/MF3/MF4

- This flameproof module contains the majority of the shearer electrical control and power distribution components
- High current carrying capacity of 400 amps (ECB2) or 500 amps (ECB3) and can accommodate trailing cables up to 185 mm² [ECB2] (2.9 in²) or 240 mm² [ECB3] (9.4 in²)
- All internal chassis can be ‘bench built,’ tested and stored
- Box contains various low voltage (LV) circuit breakers which can be reset through the flameproof cover (FLP) cover, reducing downtime
- An extremely powerful PMC Evo-S control system with state-of-the-art Ethernet communication and backup functionality, this allows the shearer to be operated even if the overall control system is not functioning
- This unit also contains cutter motor contactors, circuit breakers, control transformers, current monitoring, high voltage (HV) fuses, earth leakage and both visible disconnects

Haulage Transformer Box

	HTB2	HTB3
EL2000	●	
EL3000		●
EL4000		●

Haulage Transformer Box — HTB2/HTB3

- This flameproof model contains the main 253 kVA (HTB2)/350 kVA (HTB3) haulage transformers, power supplies, auxiliary transformer, drive system circuit breaker and
HTB2 one 250 kW, 600 V AC inverter drive
HTB3 two 200 kW, 600V AC inverter drives with regenerative braking module

Electrical Material

- All three models are available with headlights, cameras, methane monitoring, end displays and audible alarms
- All electrical material is designed and certified to IEC standards and also complies with other regional and national standards, such as MSHA, EAC/Ex, MA, ATEX and DGMS, as well as Australia's New South Wales and Queensland regulations

Hydraulic Material

- All hose assemblies are to ISO 6805 and proof tested to EN ISO 1402
- The hoses are assembled to Hose Assembly Standard DIN20066:201-10
- All hose and hosing is in compliance with guideline MDG 41 and MSHA regulations

Water Material

- All hose assemblies are to ISO 6805 and proof tested to EN ISO 1402
- The hoses are assembled to Hose Assembly Standard DIN20066:201-10
- All hose and hosing is in compliance with guideline MDG 41 and MSHA regulations
- All three models are available with onboard filtration, dust suppression spray bars, shearers clearers and ranging arms spray rings

Health Monitoring

- A comprehensive health monitoring system is available, including oil levels and temperatures, flows, pressures and vibration analysis

Machine Automation and Communication

- Industry-leading Automation from the Pioneer of State-based Automation.
- The shearers have a state-of-the-art distributed automation system for the control, monitoring and protection of the shearers. Its modular design allows it to be configured to meet individual control needs, from basic monitoring and protection to advanced automation and data transmission.
- The PMC Evo-S control system with state-of-the-art Ethernet communication and backup functionality allows the shearer to be operated even if the overall control system is not functioning.
- The shearer is equipped with a state-of-the-art industry PC in a flameproof housing with plenty of computing power, allowing flexibility to upgrade to future features such as condition monitoring.
- A Programmable Logic Controller (PLC) takes care of basic machine control tasks, ensuring that coal is produced.
- Unlike competitor systems, the modularity of the longwall system to operate in “fault-tolerant” mode, even when there is a problem with the overall automation system.
- In other words, integrated automation does not prevent control via individual PLC’s in order to keep production up and running.
- Levels of automation:
 - Zone-based automation “Navigator 1”
 - State-based shearer automation “Navigator 2”
 - Integrated longwall automation with “Navigator 2+3”
 - “Longwall Navigator” for improved face alignment and horizon control

Optional Machine Mounted Coal Sizer — CS200 (EL3000 and EL4000)

- Transmission rating of 200 kW @ 50 Hz (320 hp @ 60 Hz)
- Quillshaft transmission protection
- Drum speed of 200 RPM (240 @ 60 Hz)
- Drum diameter 900 mm (35.5 in) over picks
- Integral water cooling for transmission and motor
- Square drum hub drive for drum
- Complete with anti-shock lift mechanism (unique to Caterpillar)
- Available motor rating 200 kW @ 50 Hz (320 hp @ 60 Hz)

EL2000 Longwall Shearer

Typical Machine Configurations (Machine Sketch)

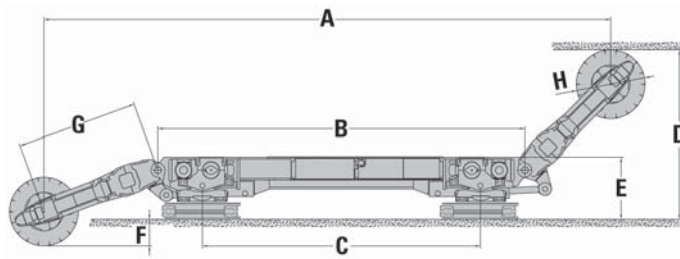

Low

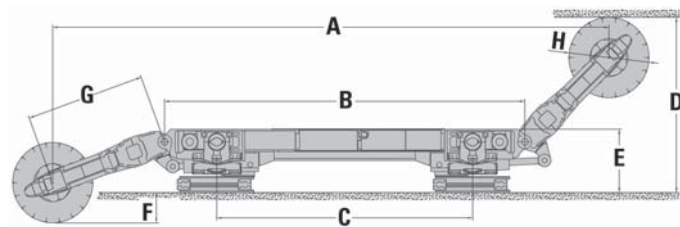

Mid-Low

Dimensions (All dimensions are approximate.)

	Low		Mid-Low	
A Distance between Drums with Arms Horizontal	14 155 mm	537"	14 155 mm	537"
B Distance between Ranging Arm Hinge Points	8525 mm	336"	8525 mm	336"
C Distance between Trapping Shoe Centers	6453 mm	254"	6056 mm	238"
D Cutting Heights:				
Maximum	3930 mm	155"	4135 mm	163"
Minimum	1800 mm	71"	1900 mm	75"
E Height to Top of Machine Main Body	1444 mm	56.8"	1495 mm	58.8"
F Shearer Drum Undercut of Floor	619 mm	24"	718 mm	28.3"
G Ranging Arm Length (Hinge to Drum)	2815 mm	111"	2815 mm	111"
H Diameter of Shearer Cutting Drum	1600 mm	63"	1900 mm	75"

EL2000 Longwall Shearer

Typical Machine Configurations (Machine Sketch)

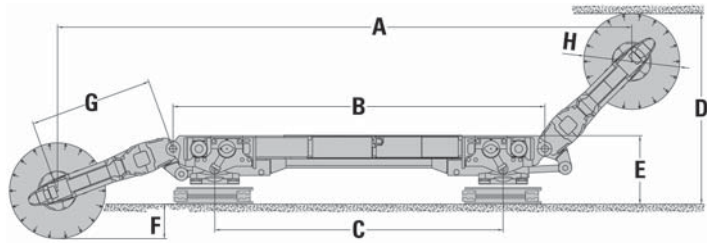

Mid-High

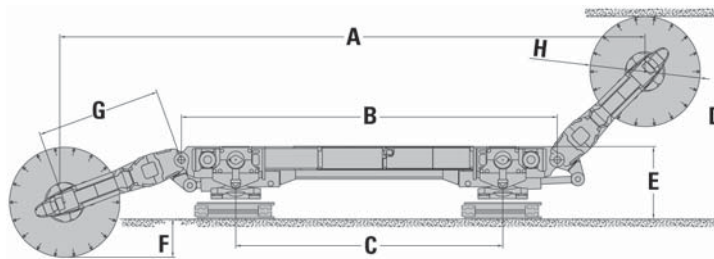

High

Dimensions (All dimensions are approximate.)

	Mid-High		High	
A Distance between Drums with Arms Horizontal	14 155 mm	537"	14 155 mm	537"
B Distance between Ranging Arm Hinge Points	8525 mm	336"	8525 mm	336"
C Distance between Trapping Shoe Centers	6612 mm	260"	6065 mm	238"
D Cutting Heights:				
Maximum	4360 mm	172"	4570 mm	180"
Minimum	2200 mm	87"	2500 mm	98"
E Height to Top of Machine Main Body	1571 mm	61.8"	1647 mm	64.8"
F Shearer Drum Undercut of Floor	793 mm	31.2"	866 mm	34"
G Ranging Arm Length (Hinge to Drum)	2815 mm	111"	2815 mm	111"
H Diameter of Shearer Cutting Drum	2200 mm	87"	2500 mm	98"

EL2000 Longwall Shearer

Typical Machine Configurations (Cross Section)

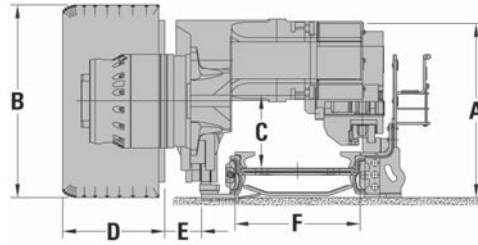

Low

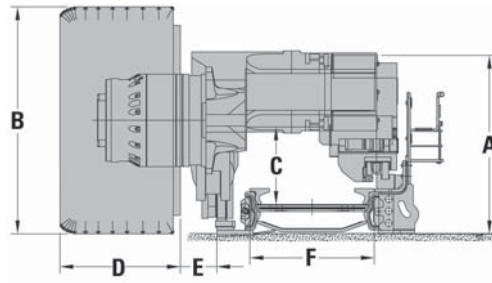

Mid-Low

Dimensions (All dimensions are approximate.)

	Low		Mid-Low	
A Machine Height over Main Body	1444 mm	56.8"	1495 mm	58.8"
B Ranging Arm Cutting Drum Diameter	1600 mm	63"	1900 mm	75"
C Vertical Tunnel Clearance	598 mm	23.5"	649 mm	25.5"
D Maximum Cutting Drum Overall Width	1150 mm	45.3"	1150 mm	45.3"
E Clearance from Drum to AFC Toeplate	300 mm	12"	300 mm	12"
F AFC Pan Width:				
Maximum	1342 mm	53"	1342 mm	53"
Minimum	1032 mm	41"	1032 mm	41"

EL2000 Longwall Shearer

Typical Machine Configurations (Cross Section)

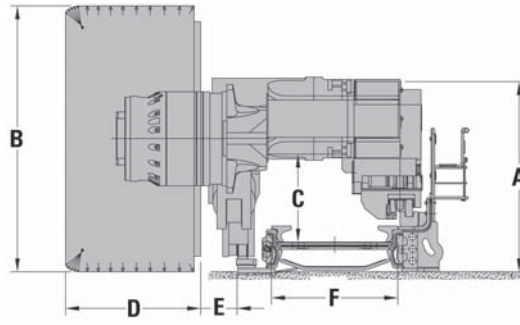

Mid-High

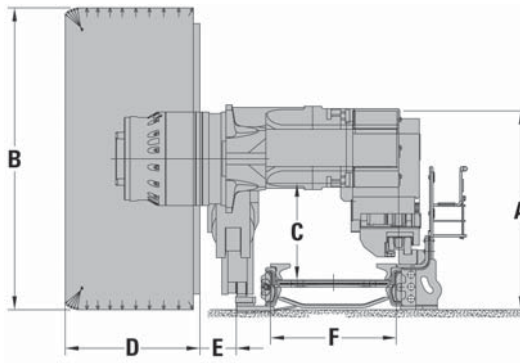

High

Dimensions (All dimensions are approximate.)

	Mid-High		High	
A Machine Height over Main Body	1571 mm	61.8"	1647 mm	64.8"
B Ranging Arm Cutting Drum Diameter	2200 mm	87"	2500 mm	98"
C Vertical Tunnel Clearance	725 mm	28.5"	801 mm	31.5"
D Maximum Cutting Drum Overall Width	1150 mm	45.3"	1150 mm	45.3"
E Clearance from Drum to AFC Toeplate	300 mm	12"	300 mm	12"
F AFC Pan Width:				
Maximum	1342 mm	53"	1342 mm	53"
Minimum	1032 mm	41"	1032 mm	41"

EL3000 Longwall Shearer

Typical Machine Configurations (Machine Sketch)

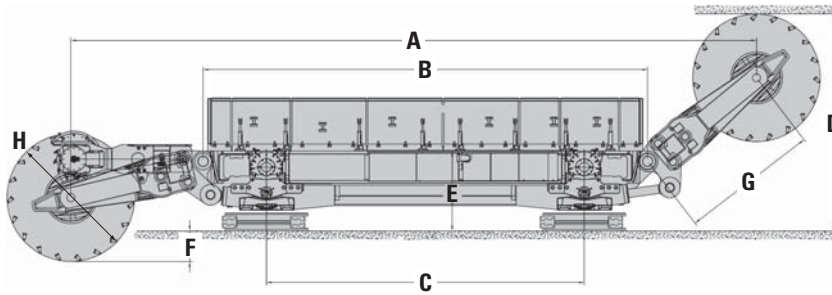

Low

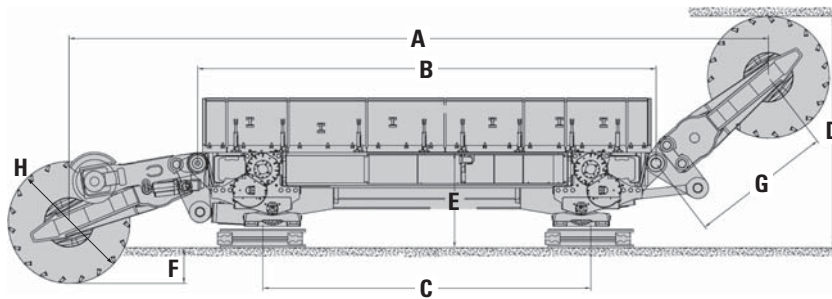

Medium

Dimensions (All dimensions are approximate.)

	Low		Medium	
A Distance between Drums with Arms Horizontal	15 200 mm	598"	15 200 mm	598"
B Distance between Ranging Arm Hinge Points	9400 mm	370"	9400 mm	370"
C Distance between Trapping Shoe Centers	6724 mm	265"	6332 mm	249"
D Maximum Cutting Height for Seam	4400 mm	173"	4500 mm	177"
E Height to Top of Machine Main Body	1690 mm	67"	1950 mm	77"
F Shearer Drum Undercut of Floor	550 mm	22"	519 mm	21"
G Ranging Arm Length (Hinge to Drum)	2900 mm	114"	2900 mm	114"
H Diameter of Shearer Cutting Drum	2600 mm	102"	2700 mm	106"

EL3000 Longwall Shearer

Typical Machine Configurations (Machine Sketch)

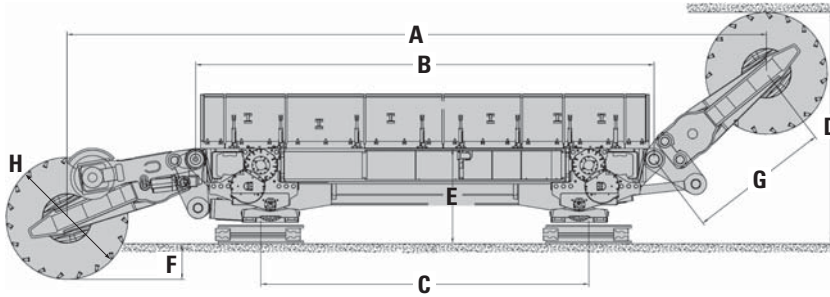

High

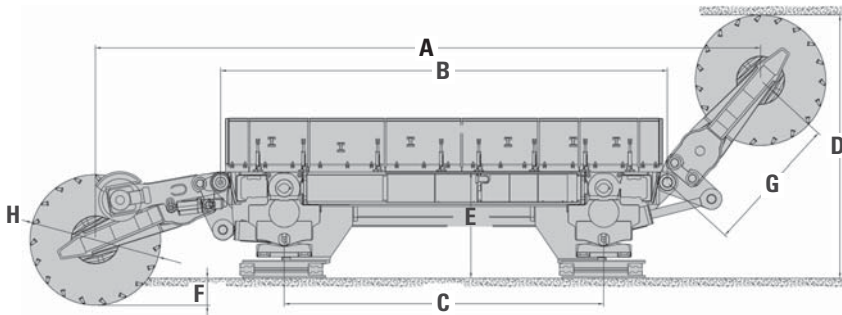

Super-High

Dimensions (All dimensions are approximate.)

	High		Super-High	
A Distance between Drums with Arms Horizontal	15 200 mm	598"	15 200 mm	598"
B Distance between Ranging Arm Hinge Points	9400 mm	370"	9400 mm	370"
C Distance between Trapping Shoe Centers	6724 mm	264"	6724 mm	265"
D Maximum Cutting Height for Seam	4500 mm	177"	5532 mm	218"
E Height to Top of Machine Main Body	2110 mm	83"	2240 mm	88"
F Shearer Drum Undercut of Floor	510 mm	20"	567 mm	22"
G Ranging Arm Length (Hinge to Drum)	2900 mm	114"	2900 mm	114"
H Diameter of Shearer Cutting Drum	2700 mm	106"	2750 mm	108"

EL3000 Longwall Shearer

Typical Machine Configurations (Cross Section)

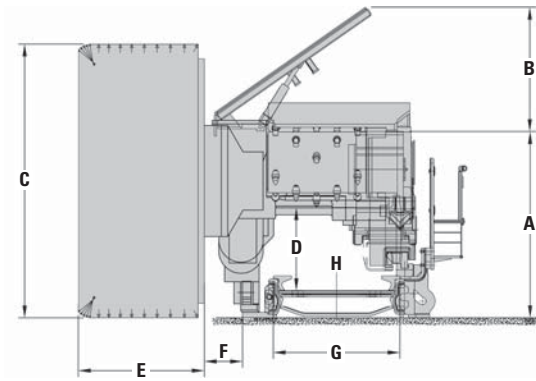

Low

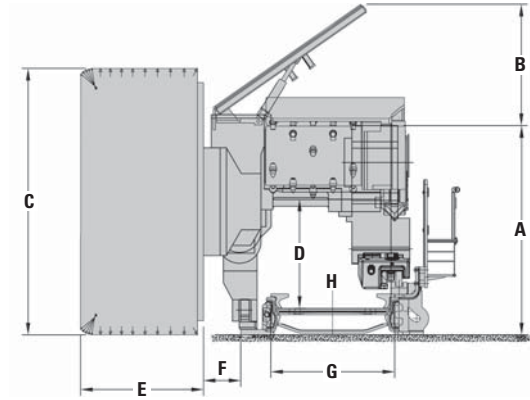

Medium

Dimensions (All dimensions are approximate.)

	Low		Medium	
A Machine Height over Main Body	1690 mm	67"	1950 mm	77"
B Top Guard Height over Main Body	1124 mm	44"	1124 mm	44"
C Ranging Arm Cutting Drum Diameter	2700 mm	106"	2700 mm	106"
D Vertical Tunnel Clearance	800 mm	32"	1000 mm	39"
E Cutting Drum Overall Width	1100 mm	43"	1100 mm	43"
F Clearance from Drum to AFC Toeplate	344 mm	14"	344 mm	14"
G AFC Pan Width	1142 mm	45"	1142 mm	45"
H CSA	0.57 m ²	6.1 ft²	0.80 m ²	8.6 ft²

EL3000 Longwall Shearer

Typical Machine Configurations (Cross Section)

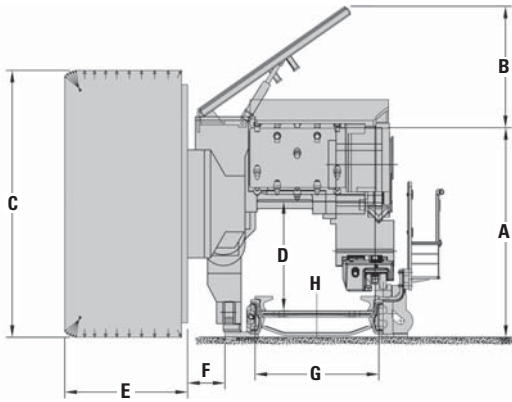

High

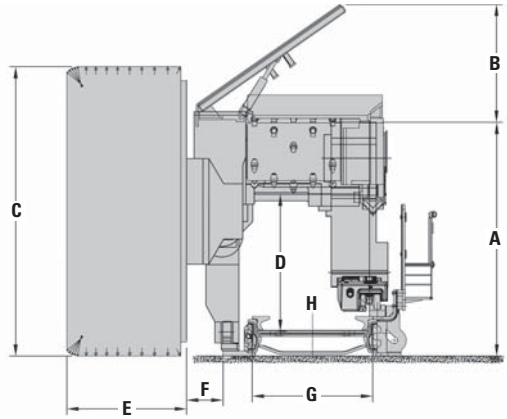

Super-High

Dimensions (All dimensions are approximate.)

	High		Super-High	
A Machine Height over Main Body	2110 mm	88"	2240 mm	88"
B Top Guard Height over Main Body	1124 mm	44"	1124 mm	44"
C Ranging Arm Cutting Drum Diameter	2700 mm	106"	2750 mm	108"
D Vertical Tunnel Clearance	1160 mm	45"	1300 mm	51"
E Cutting Drum Overall Width	1100 mm	43"	1100 mm	43"
F Clearance from Drum to AFC Toeplate	344 mm	14"	344 mm	14"
G AFC Pan Width	1142 mm	45"	1142 mm	45"
H CSA	0.95 m ²	10.2 ft²	1.06 m ²	11.4 ft²

EL4000 Longwall Shearer

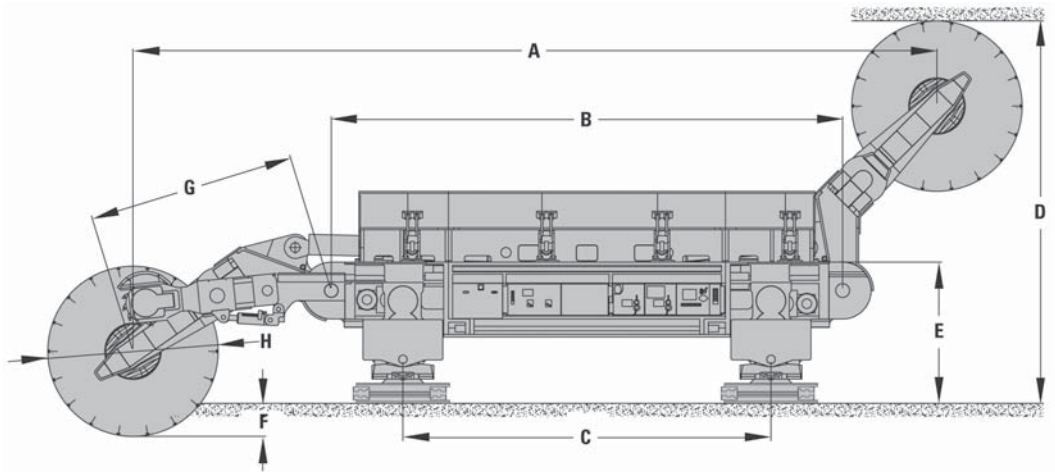

Dimensions (All dimensions are approximate.)

Model	EL3000	
A Distance between Drums with Arms Horizontal	17 008 mm	670"
B Distance between Ranging Arm Hinge Points	9600 mm	378"
C Distance between Trapping Shoe Centers	6910 mm	272"
D Maximum Cutting Height for Seam	7188 mm	283"
E Height to Top of Machine Main Body	2656 mm	105"
F Shearer Drum Undercut of Floor	621 mm	24"
G Ranging Arm Length (Hinge to Drum)	3893 mm	153"
H Diameter of Shearer Cutting Drum	3200 mm	126"

EL4000 Longwall Shearer

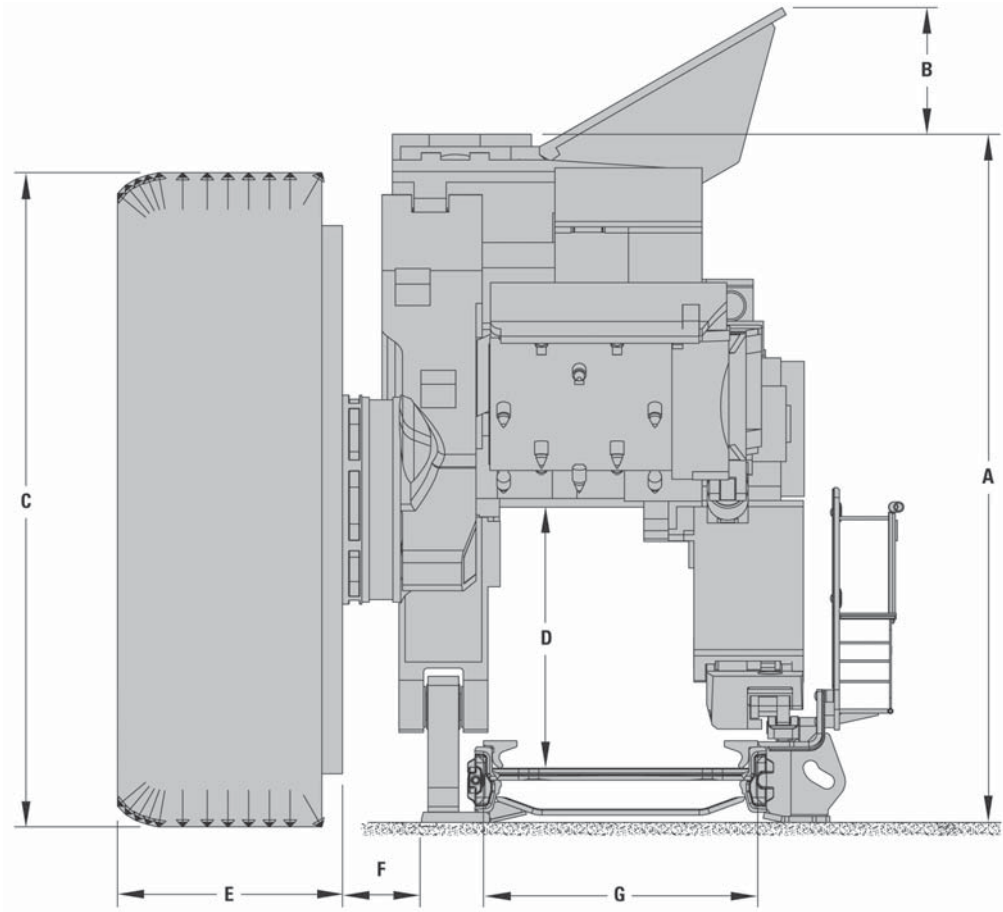

Dimensions (All dimensions are approximate.)

Model	EL3000	
A Machine Height over Main Body	3366 mm	133"
B Top Guard Height over Main Body	620 mm	24"
C Ranging Arm Cutting Drum Diameter	3200 mm	126"
D Vertical Tunnel Clearance	1277 mm	50"
E Cutting Drum Overall Width	1100 mm	43"
F Clearance from Drum to AFC Toeplate	380 mm	15"
G AFC Pan Width	1342 mm	53"

Optional Accessories

Model	EL2000	EL3000	EL4000
Multi-piece Mainframe	○	○	○
Cowl	○	○	○
Spall Guards	○	○	○
Coal Sizer:			
100 kW (134 hp)	○	○	○
200 kW (268 hp)	–	○	○
Trapping Shoe Ix (Insert Exchange)	● ○	● ○	● ○
Shearer Clearer	○	○	○
Spray Bars	○	○	○
Central Lubrication System	●	●	●
PMC Evo-S	●	●	●
Gate End Data Connection:			
Powerline	●	●	●
Fiber Optics	–	○	○
WLAN	●	●	●
IPC	○	○	○
Zone-based Automation “Navigator 1”	○	○	○
State-based Shearer Automation “Navigator 2”	○	○	○
Integrated Longwall Automation with “Navigator 2 + 3”	○*	○*	○*
“Longwall Navigator” for Improved Face Alignment and Horizon Control Incorporating LASC Technology	○*	○*	○*
VibraGuard	○	○	○
Cameras	○	○	○
Condition Monitoring	○	○	○

- = Standard equipment
- = Available equipment
- * = Only with Cat longwall equipment

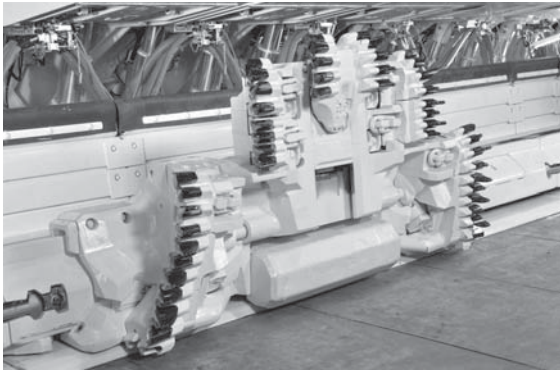
AUTOMATED PLOW SYSTEMS**Features****High-level Automation**

- Preferred longwall mining machine for seams under 1.8 m (5.9 ft).
- Fully automated longwall mining system for medium and thin seams from 0.8–2.3 m (1.8–7.5 ft).
- High traveling speed up to 3.6 m/sec (720 ft/min).
- Most powerful system available with up to 2×800 kW (2×1080 hp).
- Maximum capacity 3500 tonnes/hr (3858 tons/hr).
- Overload protection.
- Load sharing.
- Minimum dust generation.
- Low operating costs.
- Effective horizon control and incremental plowing for full automation without operators being required on the face.

**Gliding Plow
GH800**

Model	Base-Plate Plow RHH800		Gliding Plow GH800	
Plow Length — Single Plow	2384 mm	7.82 ft	2712 mm	8.89 ft
Plow Heights	600-855 mm 820-1120 mm 1085-1385 mm 1350-1650 mm	1.97-2.81 ft 2.70-3.67 ft 3.56-4.54 ft 4.43-5.41 ft	800-1060 mm 1020-1320 mm 1285-1585 mm	2.62-3.47 ft 3.34-4.33 ft 4.21-5.20 ft
Plow Heights (with gobside support)	—		1570-1735 mm 1700-2000 mm	5.15-5.69 ft 5.57-6.56 ft
Mechanical Height Adjustment	255-300 mm	0.83-0.98 ft	180-300 mm	0.59-0.98 ft
Cutting Depth	max. 190 mm	max 0.62 ft	195 mm	0.64 ft
Weights:	4400-6400 kg	9700-14,109 lb	—	
Single Plow	—		4080-6630 kg	8995-14,616 lb
Bottom Bit Positions:				
Position 1	+24 mm	+0.08 ft	+12 mm	+0.04 ft
Position 2	-5 mm	-0.02 ft	-10 mm	-0.03 ft
Position 3	-18 mm	-0.06 ft	-20 mm	-0.06 ft
Position 4	-37 mm	-0.12 ft	-34 mm	-0.11 ft
Maximum Drive Power	2 × 400 kW	2 × 536 hp	2 × 400 kW	2 × 536 hp
Coal Hardness	Soft-hard coal		Soft-hard coal	
Maximum Seam Inclination	Up to 60°		Up to 60°	
Maximum Plow Speed	2.5 m/sec	500 ft/min	3.0 m/sec	600 ft/min

Model	Gliding Plow GH800B		Gliding Plow GH1600	
Plow Length — Single Plow	2636 mm	8.65 ft	2969 mm	9.74 ft
Plow Heights	750-1030 mm 1000-1285 mm 1270-1550 mm	2.64-3.38 ft 3.28-4.22 ft 4.17-5.09 ft	980-1230 mm 1180-1480 mm 1445-1745 mm	3.22-4.04 ft 3.87-4.86 ft 4.73-5.73 ft
Plow Heights (with gobside support)	1535-1700 mm 1685-1965 mm	5.04-5.58 ft 5.53-6.45 ft	1860-2160 mm	6.10-7.08 ft
Mechanical Height Adjustment	180-280 mm	0.59-0.92 ft	180-300 mm	0.59-0.98 ft
Cutting Depth	205 mm	0.67 ft	210 mm	0.69 ft
Weights:	—		5600-8600 kg	12,345-18,960 lb
Single Plow	4385-5625 kg	10,660-12,401 lb	—	
Bottom Bit Positions:				
Position 1	+19 mm	+0.06 ft	+12 mm	+0.04 ft
Position 2	-9 mm	-0.03 ft	-10 mm	-0.03 ft
Position 3	-22 mm	-0.07 ft	-21 mm	-0.07 ft
Position 4	-39 mm	-0.13 ft	-35 mm	-0.11 ft
Maximum Drive Power	2 × 400 kW	2 × 536 hp	2 × 800 kW	2 × 1080 hp
Coal Hardness	Soft-hard coal		Medium-extremely hard coal	
Maximum Seam Inclination	60°		Up to 60°	
Maximum Plow Speed	3.0 m/sec	600 ft/min	3.6 m/sec	720 ft/min

Dimensions RHH800 — Plow Body Setup Option 1 (All dimensions are approximate.)

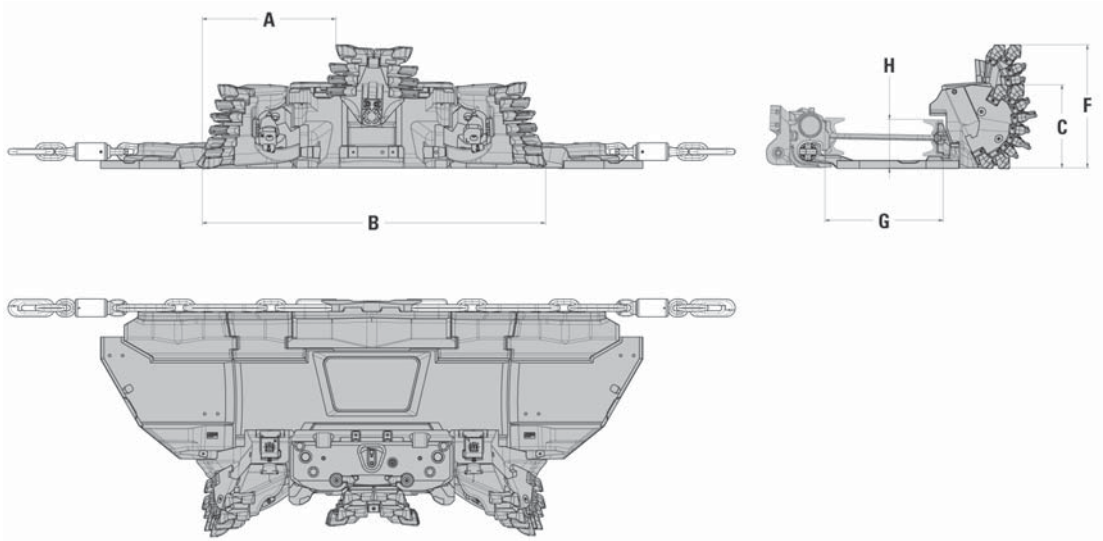

Model	RHH800 — Plow Body Setup Option 1		
A	930 mm		3.05 ft
B	2384 mm		7.82 ft
C	579 mm		1.90 ft
D		—	
E		—	
F	855 mm		2.81 ft
G	822 mm		2.70 ft
H	377 mm		1.11 ft

Dimensions RHH800 — Plow Body Setup Option 2 (All dimensions are approximate.)

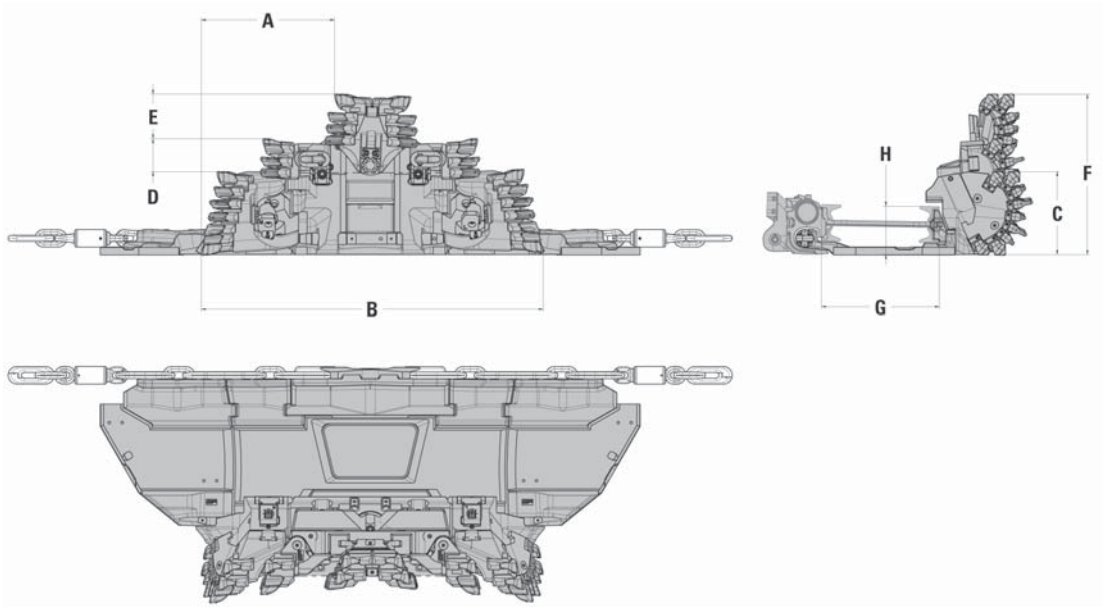

Model

RHH800 — Plow Body Setup Option 2

A	930 mm	3.05 ft
B	2384 mm	7.82 ft
C	579 mm	1.90 ft
D	229 mm	0.75 ft
E	312 mm	1.02 ft
F	1120 mm	3.67 ft
G	822 mm	2.70 ft
H	377 mm	1.11 ft

Dimensions RHH800 — Plow Body Setup Option 3 (All dimensions are approximate.)

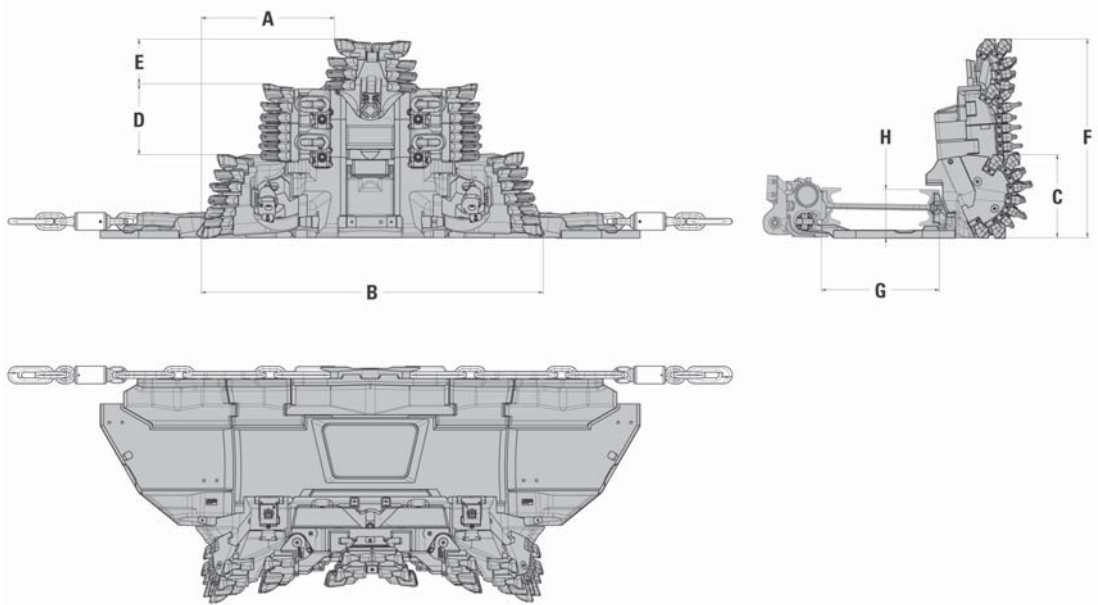

Model

RHH800 — Plow Body Setup Option 3

A	930 mm	3.05 ft
B	2384 mm	7.82 ft
C	579 mm	1.90 ft
D	494 mm	1.62 ft
E	312 mm	1.02 ft
F	1385 mm	4.54 ft
G	822 mm	2.70 ft
H	377 mm	1.11 ft

Dimensions RHH800 — Plow Body Setup Option 4 (All dimensions are approximate.)

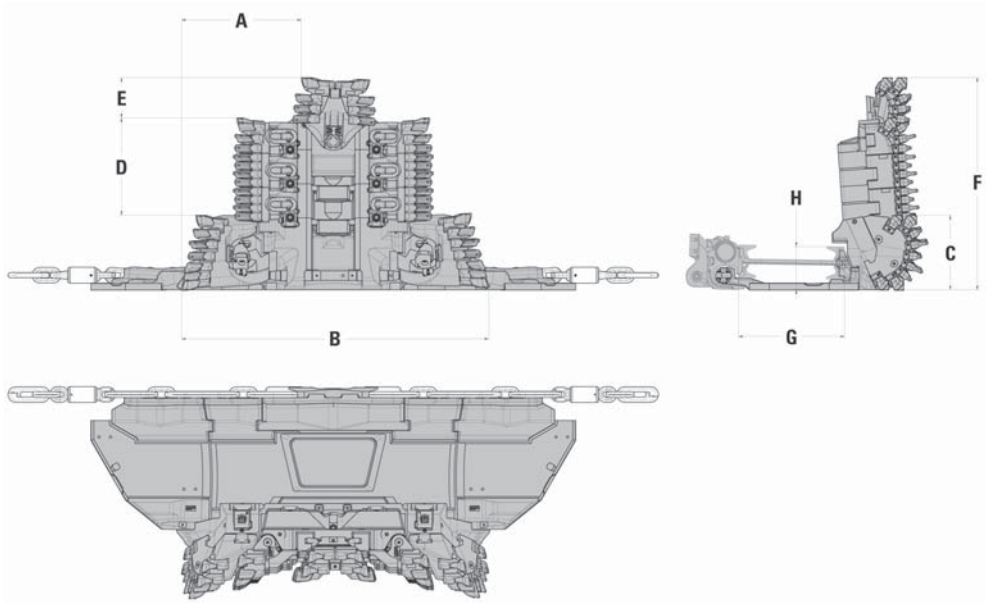

Model

RHH800 — Plow Body Setup Option 4

A	930 mm	3.05 ft
B	2384 mm	7.82 ft
C	579 mm	1.90 ft
D	759 mm	2.49 ft
E	312 mm	1.02 ft
F	1650 mm	5.41 ft
G	822 mm	2.70 ft
H	377 mm	1.11 ft

Dimensions GH800 — Plow Body Setup Option 1 (All dimensions are approximate.)

Stageless Height Adjustment
Adjustable Range 260 mm (0.89 ft)
10 Revolutions = 25 mm (0.08 ft) Pass

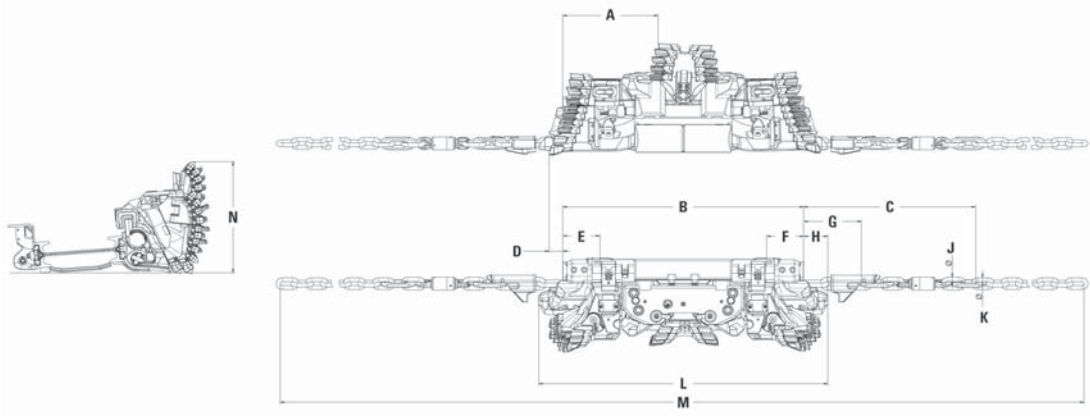

Model	GH800 — Plow Body Setup Option 1	
A	894 mm	2.93 ft
B	2261 mm	7.41 ft
C	1613 mm	5.29 ft
D	128 mm	0.41 ft
E	349 mm	1.14 ft
F	349 mm	1.14 ft
G	541 mm	1.77 ft
H	226 mm	0.74 ft
J	42 mm	0.14 ft
K	38 mm	0.24 ft
L	2712 mm	8.89 ft
M	14 529 mm	47.67 ft
N	1060 mm	3.47 ft

Dimensions GH800 — Plow Body Setup Option 2 (All dimensions are approximate.)

Stageless Height Adjustment
Adjustable Range 300 mm (0.98 ft)
10 Revolutions = 25 mm (0.08 ft) Pass

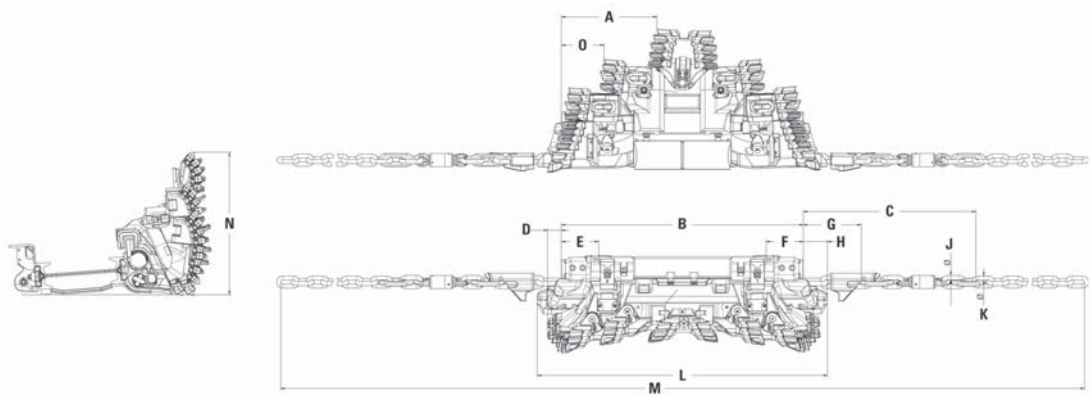

Model	GH800 — Plow Body Setup Option 2	
A	894 mm	2.93 ft
B	2261 mm	7.41 ft
C	1613 mm	5.29 ft
D	128 mm	0.41 ft
E	349 mm	1.14 ft
F	349 mm	1.14 ft
G	541 mm	1.77 ft
H	226 mm	0.74 ft
J	42 mm	0.14 ft
K	38 mm	0.24 ft
L	2712 mm	8.89 ft
M	14 529 mm	47.67 ft
N	1320 mm	4.33 ft
O	398 mm	1.31 ft

Dimensions GH800 — Plow Body Setup Option 3 (All dimensions are approximate.)

Stageless Height Adjustment
Adjustable Range 300 mm (0.98 ft)
10 Revolutions = 25 mm (0.08 ft) Pass

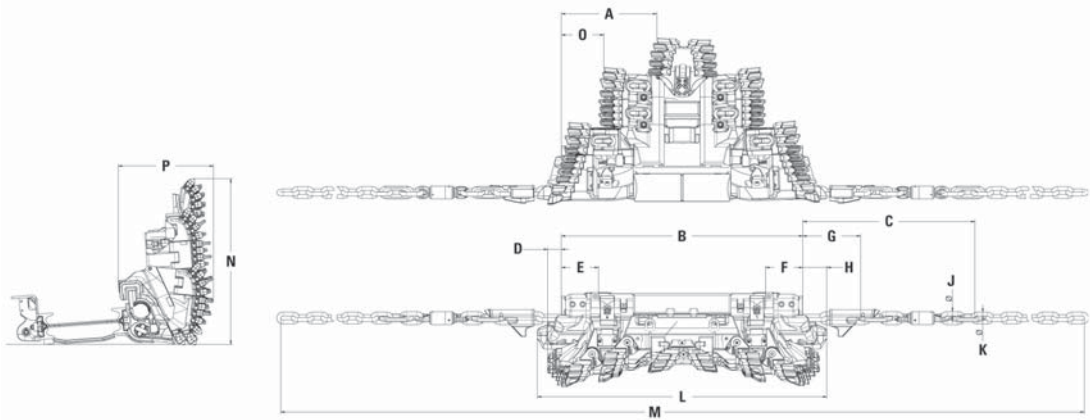

Model	GH800 — Plow Body Setup Option 3	
A	894 mm	2.93 ft
B	2261 mm	7.41 ft
C	1613 mm	5.29 ft
D	128 mm	0.41 ft
E	349 mm	1.14 ft
F	349 mm	1.14 ft
G	541 mm	1.77 ft
H	226 mm	0.74 ft
J	42 mm	0.14 ft
K	38 mm	0.24 ft
L	2712 mm	8.89 ft
M	14 529 mm	47.67 ft
N	1585 mm	5.20 ft
O	398 mm	1.31 ft
P	891 mm	2.92 ft

Dimensions GH800 — Plow Body Setup Option 4 (All dimensions are approximate.)

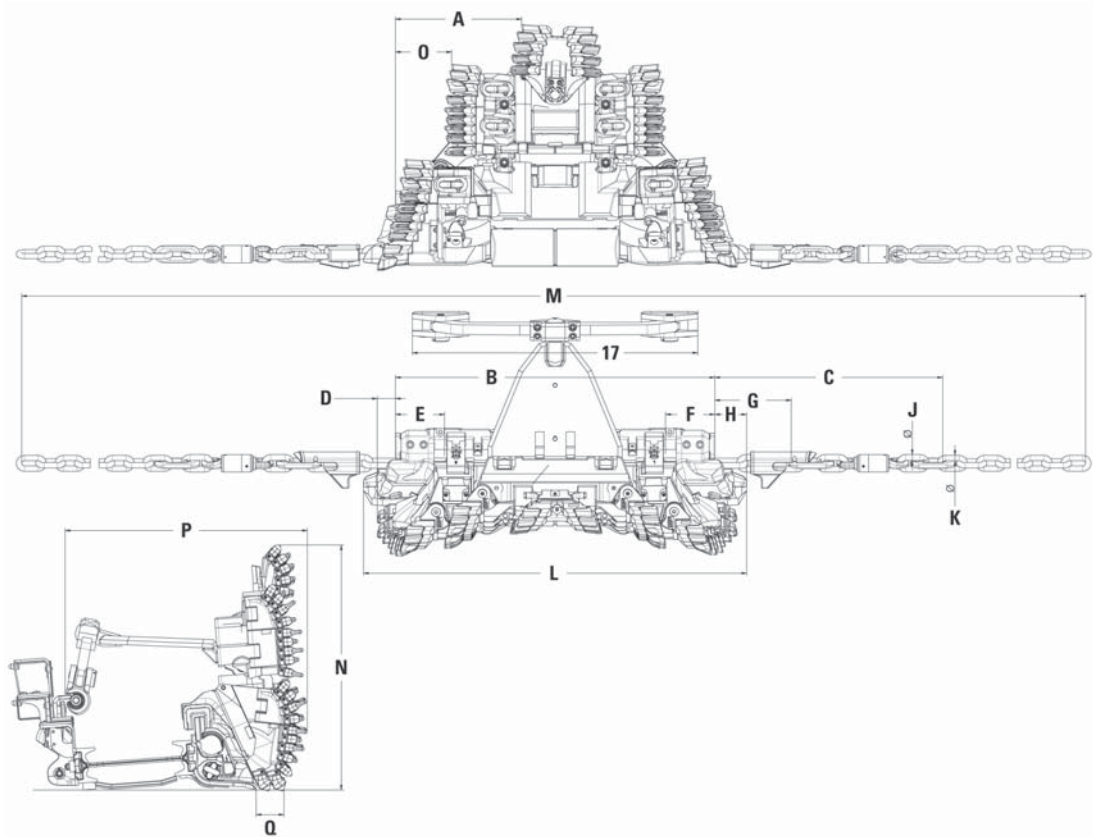

Model		GH800 — Plow Body Setup Option 4			
A	894 mm	2.93 ft	K	38 mm	0.24 ft
B	2261 mm	7.41 ft	L	2712 mm	8.89 ft
C	1613 mm	5.29 ft	M	14 529 mm	47.67 ft
D	128 mm	0.41 ft	N	1735 mm	5.69 ft
E	349 mm	1.14 ft	O	398 mm	1.31 ft
F	349 mm	1.14 ft	P	1714 mm	5.62 ft
G	541 mm	1.77 ft	Q	196 mm	0.64 ft
H	226 mm	0.74 ft	R	2020 mm	6.62 ft
J	42 mm	0.14 ft			

Dimensions GH800 — Plow Body Setup Option 5 (All dimensions are approximate.)

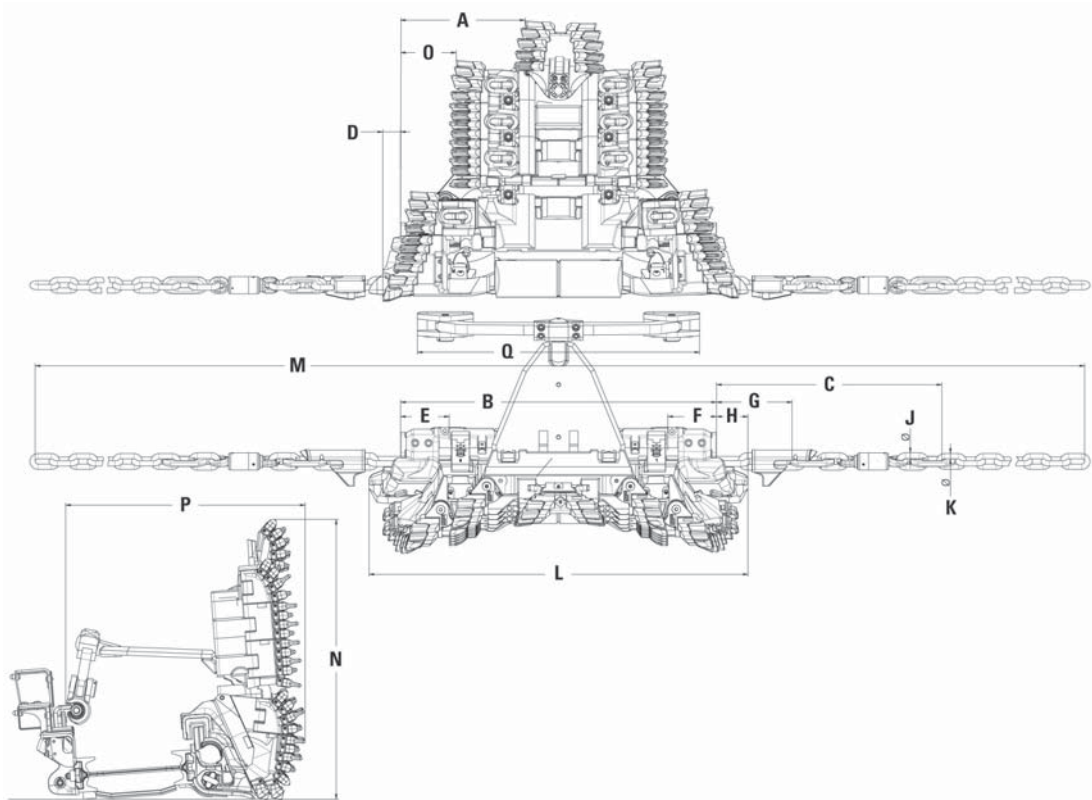

Model

GH800 — Plow Body Setup Option 5

A	894 mm	2.93 ft	J	42 mm	0.14 ft
B	2261 mm	7.41 ft	K	38 mm	0.24 ft
C	1613 mm	5.29 ft	L	2712 mm	8.89 ft
D	128 mm	0.41 ft	M	14 529 mm	47.67 ft
E	348.5 mm	1.14 ft	N	2000 mm	6.56 ft
F	348.5 mm	1.14 ft	O	398 mm	1.31 ft
G	541 mm	1.77 ft	P	1714 mm	5.62 ft
H	225.5 mm	0.73 ft	Q	2020 mm	6.62 ft

Dimensions GH800B — Plow Body Setup Option 1 (All dimensions are approximate.)

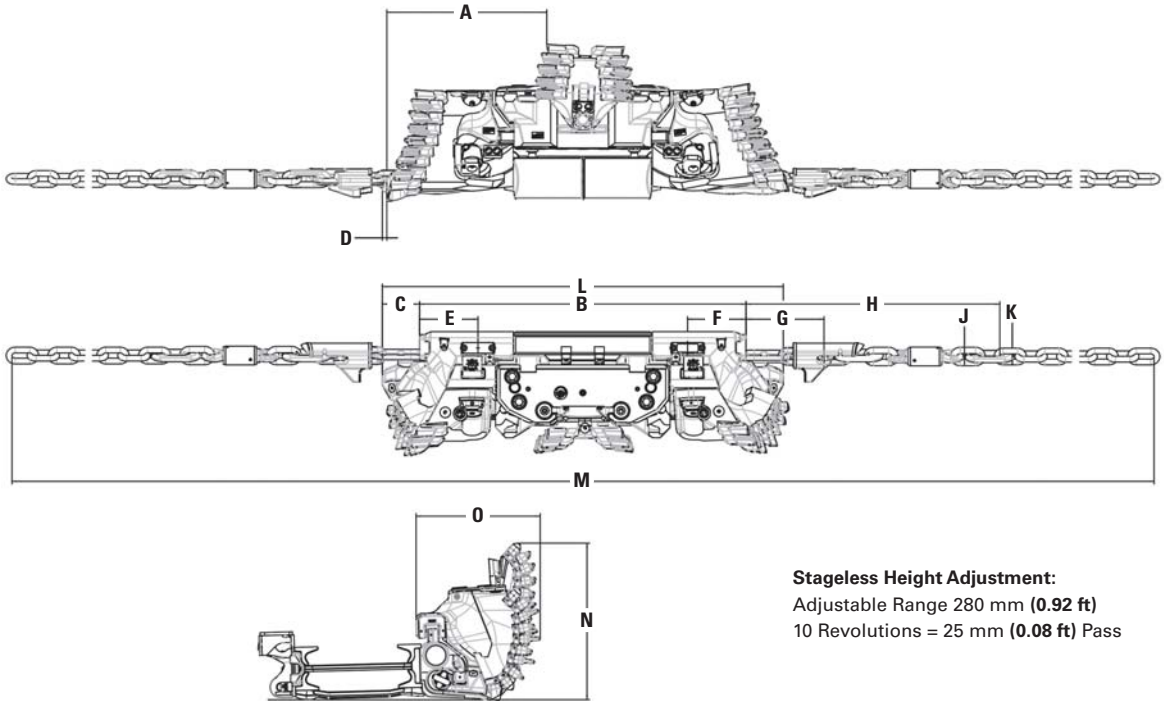

Stageless Height Adjustment:
 Adjustable Range 280 mm (0.92 ft)
 10 Revolutions = 25 mm (0.08 ft) Pass

Model

GH800B — Plow Body Setup Option 1

A	1051 mm	3.54 ft	H	1671 mm	5.48 ft
B	2146 mm	7.04 ft	J	42 mm	0.14 ft
C	245 mm	0.8 ft	K	38 mm	0.24 ft
D	30 mm	0.1 ft	L	2636 mm	8.65 ft
E	384 mm	1.26 ft	M	14 529 mm	47.67 ft
F	384 mm	1.26 ft	N	1030 mm	3.38 ft
G	515 mm	1.69 ft	O	816 mm	2.68 ft

Dimensions GH800B — Plow Body Setup Option 2 (All dimensions are approximate.)

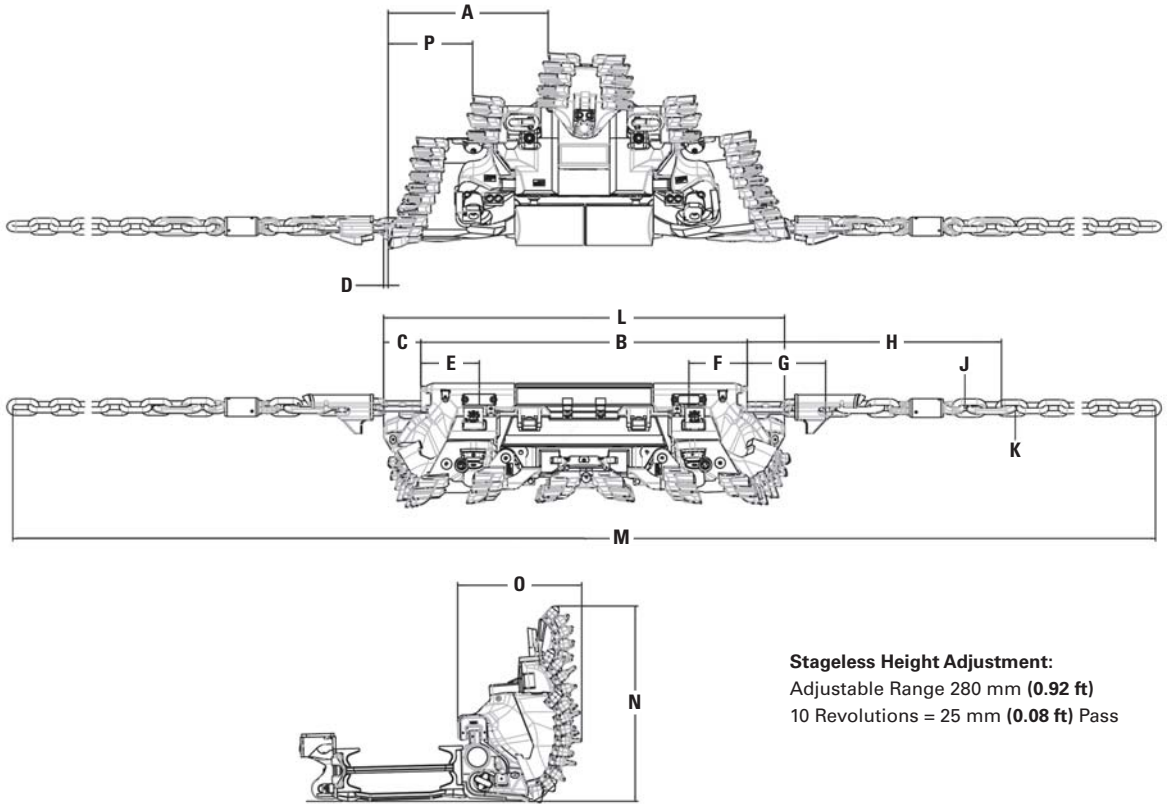

Stageless Height Adjustment:
Adjustable Range 280 mm (0.92 ft)
10 Revolutions = 25 mm (0.08 ft) Pass

Model

GH800B — Plow Body Setup Option 2

A	1051 mm	3.54 ft	J	42 mm	0.14 ft
B	2146 mm	7.04 ft	K	38 mm	0.24 ft
C	245 mm	0.8 ft	L	2636 mm	8.65 ft
D	30 mm	0.1 ft	M	14 529 mm	47.67 ft
E	384 mm	1.26 ft	N	1285 mm	4.22 ft
F	384 mm	1.26 ft	O	816 mm	2.68 ft
G	515 mm	1.69 ft	P	555 mm	1.82 ft
H	1671 mm	5.48 ft			

Dimensions GH800B — Plow Body Setup Option 3 (All dimensions are approximate.)

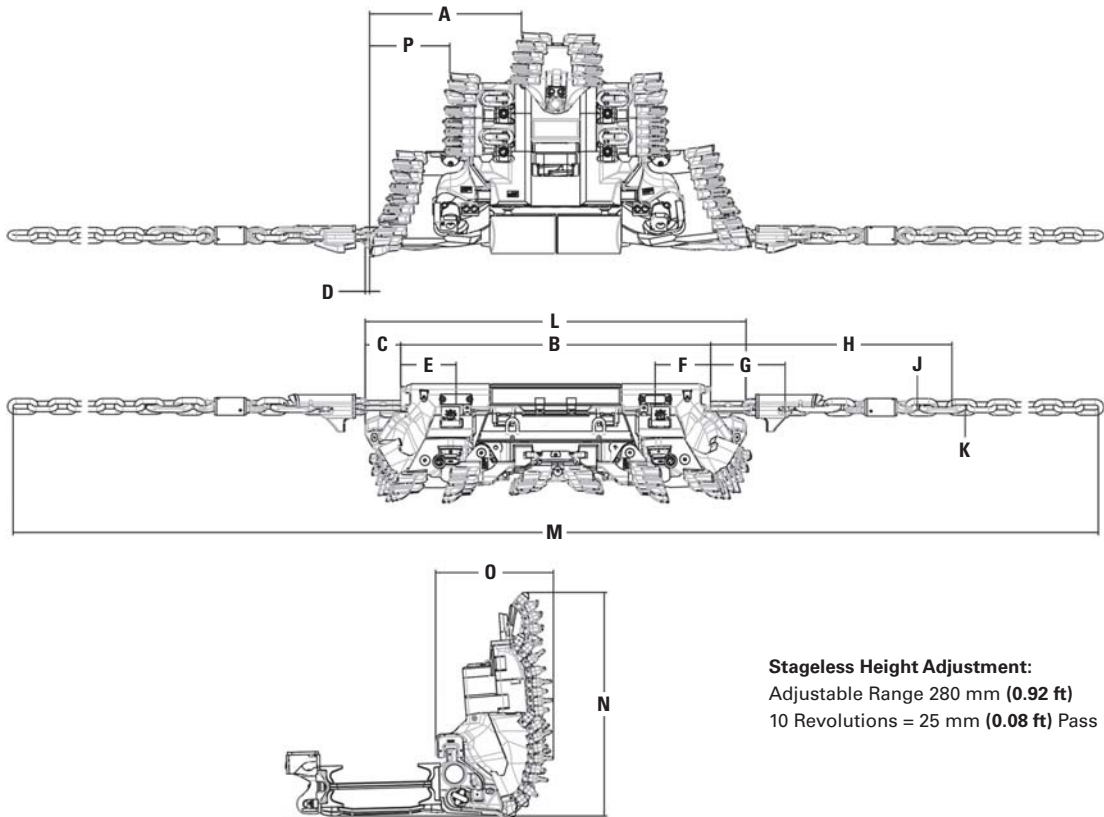

Stageless Height Adjustment:
 Adjustable Range 280 mm (0.92 ft)
 10 Revolutions = 25 mm (0.08 ft) Pass

Model

GH800B — Plow Body Setup Option 3

A	1051 mm	3.54 ft	J	42 mm	0.14 ft
B	2146 mm	7.04 ft	K	38 mm	0.24 ft
C	245 mm	0.8 ft	L	2636 mm	8.65 ft
D	30 mm	0.1 ft	M	14 529 mm	47.67 ft
E	384 mm	1.26 ft	N	1550 mm	5.09 ft
F	384 mm	1.26 ft	O	816 mm	2.68 ft
G	515 mm	1.69 ft	P	555 mm	1.82 ft
H	1671 mm	5.48 ft			

Dimensions GH800B — Plow Body Setup Option 4 (All dimensions are approximate.)

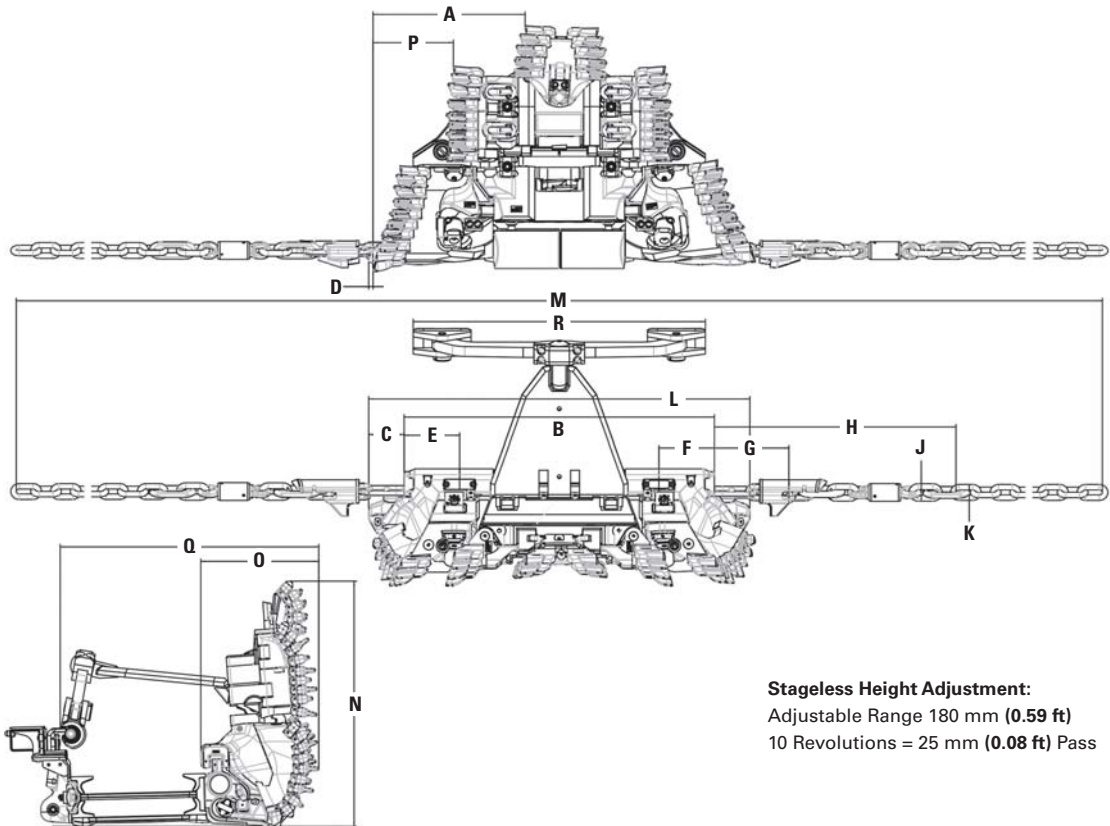

Stageless Height Adjustment:
Adjustable Range 180 mm (0.59 ft)
10 Revolutions = 25 mm (0.08 ft) Pass

Model GH800B — Plow Body Setup Option 4

A	1051 mm	3.54 ft	K	38 mm	0.24 ft
B	2146 mm	7.04 ft	L	2636 mm	8.65 ft
C	245 mm	0.8 ft	M	14 529 mm	47.67 ft
D	30 mm	0.1 ft	N	1700 mm	5.58 ft
E	384 mm	1.26 ft	O	816 mm	2.68 ft
F	384 mm	1.26 ft	P	555 mm	1.82 ft
G	515 mm	1.69 ft	Q	1788 mm	5.88 ft
H	1671 mm	5.48 ft	R	2020 mm	6.62 ft
J	42 mm	0.14 ft			

Dimensions GH800B — Plow Body Setup Option 5 (All dimensions are approximate.)

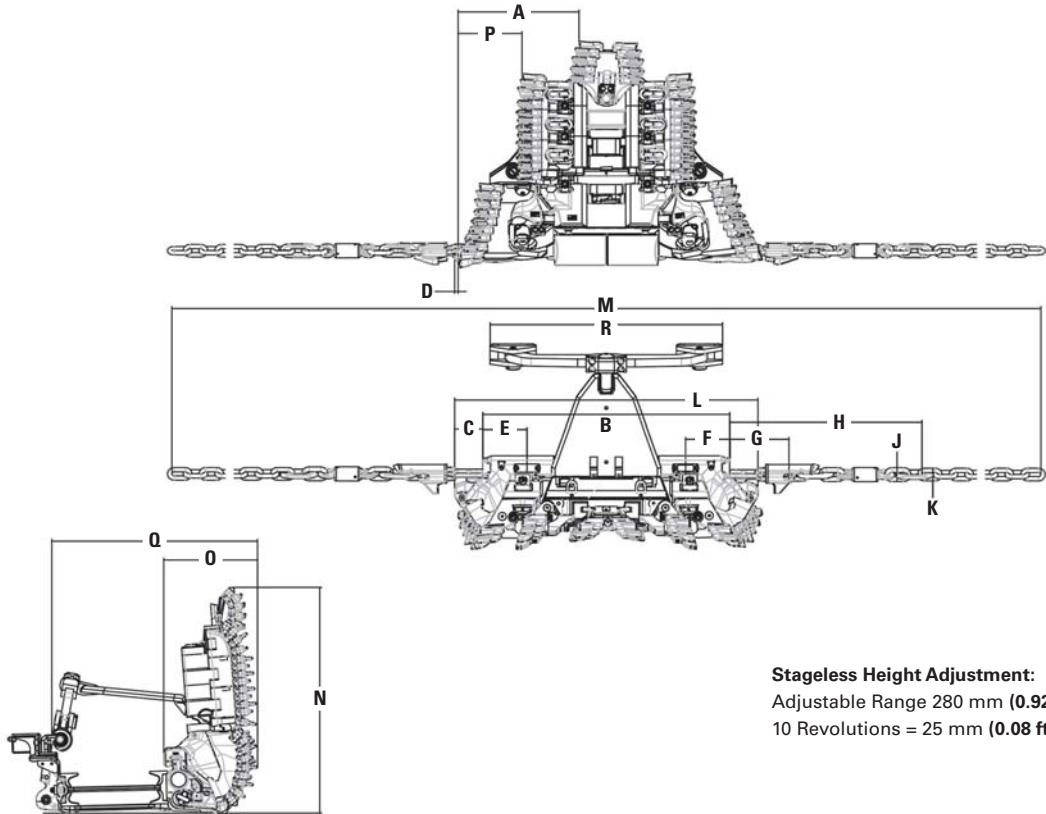

Stageless Height Adjustment:
 Adjustable Range 280 mm (0.92 ft)
 10 Revolutions = 25 mm (0.08 ft) Pass

Model GH800B — Plow Body Setup Option 5

A	1051 mm	3.54 ft	K	38 mm	0.24 ft
B	2146 mm	7.04 ft	L	2636 mm	8.65 ft
C	245 mm	0.8 ft	M	14 529 mm	47.67 ft
D	30 mm	0.1 ft	N	1965 mm	6.45 ft
E	384 mm	1.26 ft	O	816 mm	2.68 ft
F	384 mm	1.26 ft	P	555 mm	1.82 ft
G	515 mm	1.69 ft	Q	1788 mm	5.88 ft
H	1671 mm	5.48 ft	R	2020 mm	6.62 ft
J	42 mm	0.14 ft			

Dimensions GH1600 – Plow Body Setup Option 1 (All dimensions are approximate.)

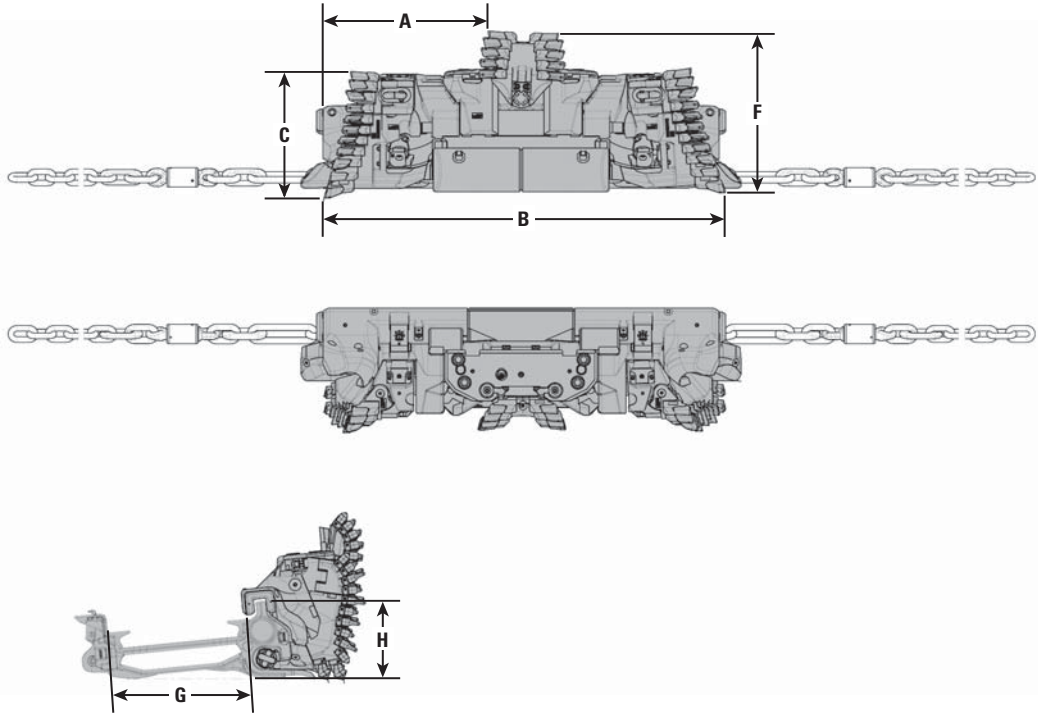

Model	GH1600 – Plow Body Setup Option 1	
A	1211 mm	3.97 ft
B	2969 mm	9.74 ft
C	931 mm	3.05 ft
D	—	—
E	—	—
F	1230 mm	4.04 ft
G	1032 mm	3.38 ft
H	578 mm	1.89 ft

Dimensions GH1600 – Plow Body Setup Option 2 (All dimensions are approximate.)

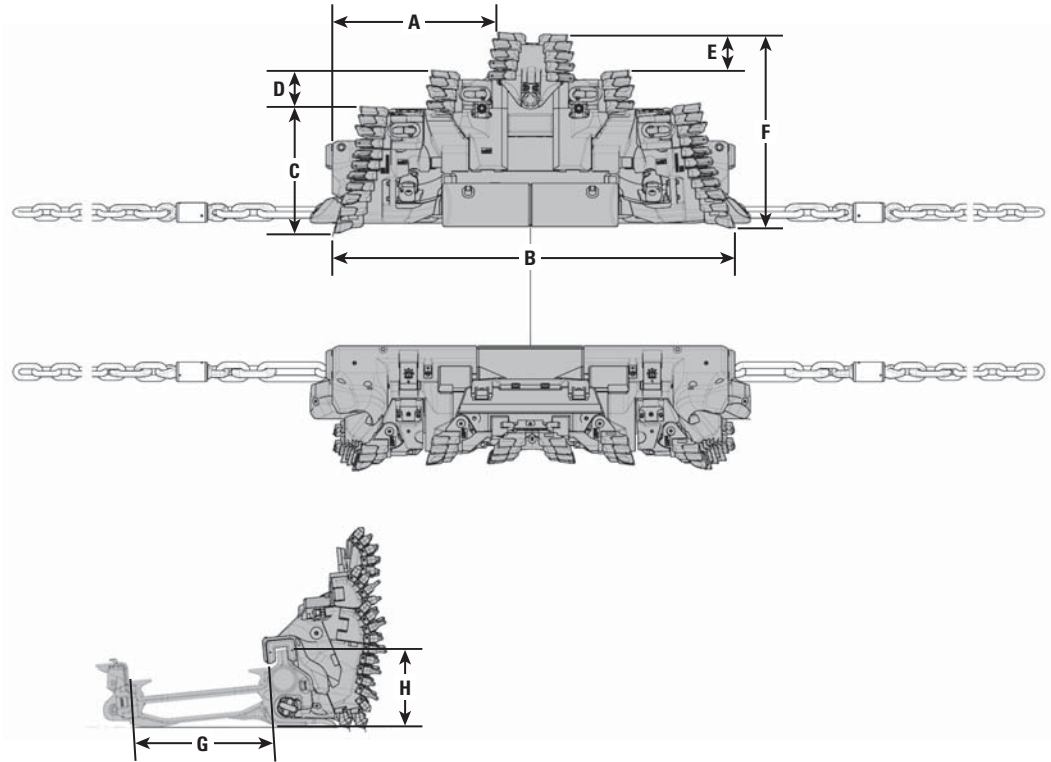

Model	GH1600 – Plow Body Setup Option 2	
A	1211 mm	3.97 ft
B	2969 mm	9.74 ft
C	931 mm	3.05 ft
D	264 mm	0.87 ft
E	285 mm	0.94 ft
F	1480 mm	4.86 ft
G	1032 mm	3.38 ft
H	578 mm	1.89 ft

Dimensions GH1600 – Plow Body Setup Option 3 (All dimensions are approximate.)

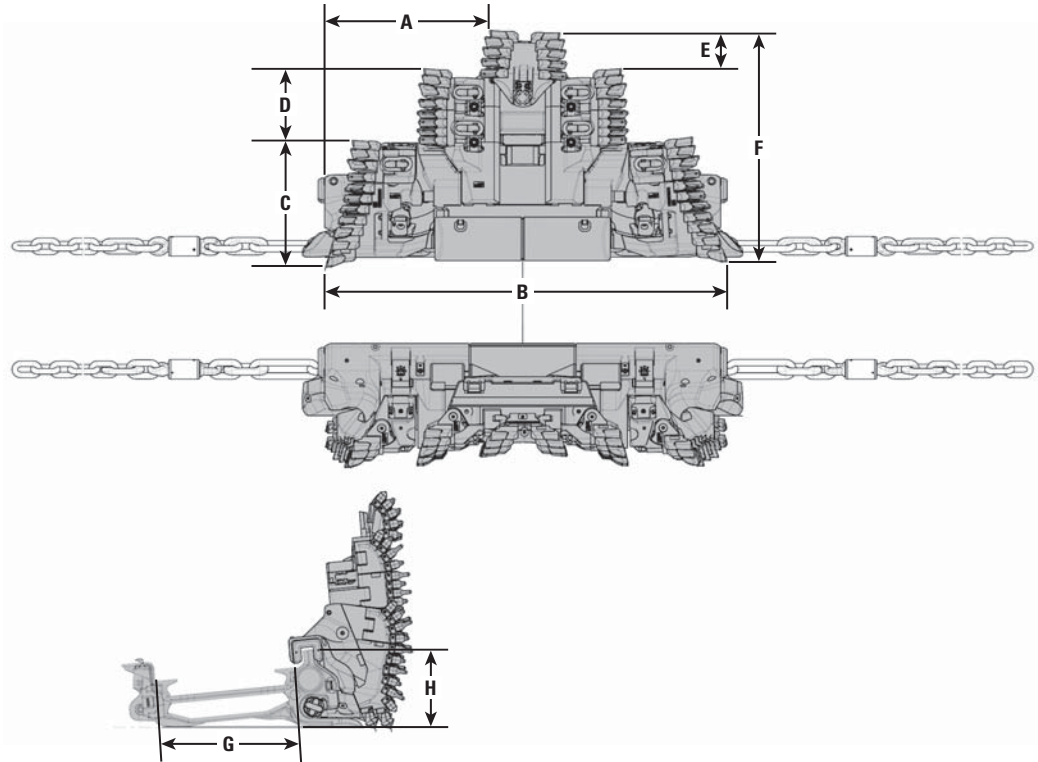

Model	GH1600 – Plow Body Setup Option 3	
A	1211 mm	3.97 ft
B	2969 mm	9.74 ft
C	931 mm	3.05 ft
D	529 mm	1.74 ft
E	285 mm	0.94 ft
F	1745 mm	5.73 ft
G	1132 mm	3.71 ft
H	578 mm	1.89 ft

Dimensions GH1600 – Plow Body Setup Option 4 (All dimensions are approximate.)

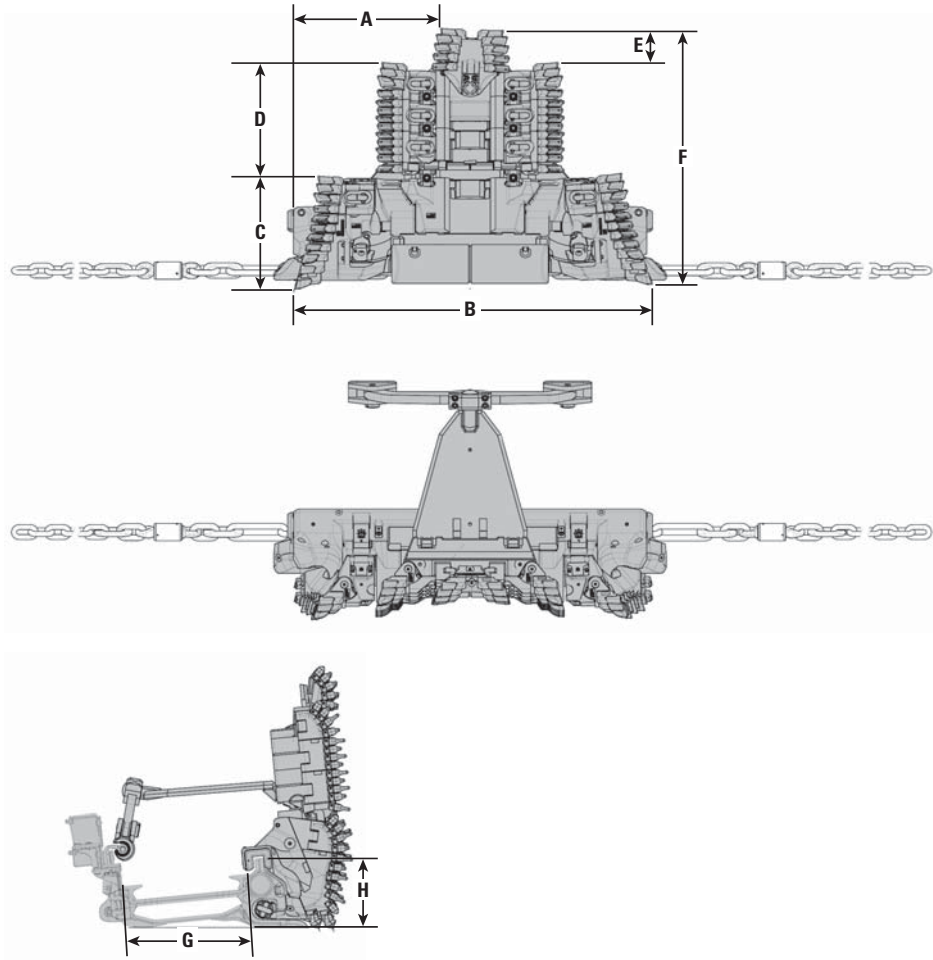

Model	GH1600 – Plow Body Setup Option 4	
A	1211 mm	3.97 ft
B	2969 mm	9.74 ft
C	931 mm	3.05 ft
D	944 mm	3.10 ft
E	285 mm	0.94 ft
F	2160 mm	7.09 ft
G	1132 mm	3.71 ft
H	578 mm	1.89 ft

PMC-R
Roof Support Control



The intrinsically-safe Cat PMC-R control units are used on shearer or plow faces to provide medium to high level of longwall automation. Each Roof Support needs to be equipped with one PMC-R control unit, a solenoid driver to operate the in-shield hydraulic functions and a set of peripheral components, like sensors for pressures and shield advance.

The PMC-R can control and display all functions of a shield and is simultaneously the interface between operator and machine (HMI).

The PMC-R system can control all individual shield functions based on a reliable network. As an interactive system, it allows the user to execute single shield functions as well as automatic functions. Important process values are continuously displayed as feedback for the operator.

Features PMC-R Control Unit

- Robust design (OS4/OS8 plugs, hose cables, stainless steel housing)
- IP 68 rating (48 h under @ 1 m [3.28 ft] under water)
- Separate Quick Stop and Local Lockout switches
- HMI with 30 multi feedback keys (sound, pressure point, led light)
- Two (2) line LCD graphical display
- Multi language support
- Maintainability (brass bar mounting, screws from the front)
- Integrated infrared
- Can control up to three (3) separate solenoid driver boards

Front View of the PMC-R

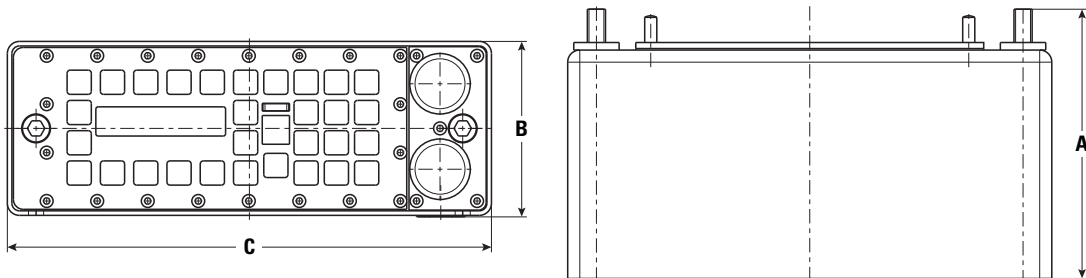

Dimensions (All dimensions are approximate.)

A Width	178 mm	7.01"
B Height	116 mm	4.57"
C Length	320 mm	12.60"

Rear Side View of the PMC-R

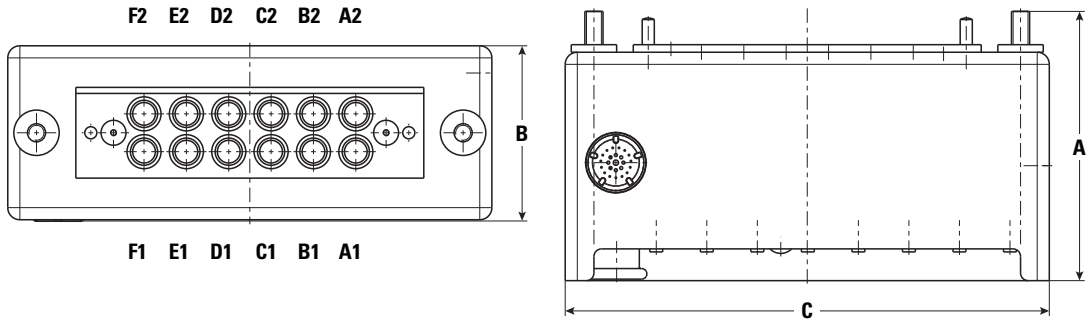

Dimensions (All dimensions are approximate.)

A Width	178 mm	7.01"
B Height	116 mm	4.57"
C Length	320 mm	12.60"

Exemplarily System Layout of a PMC-R System (Shearer Face)

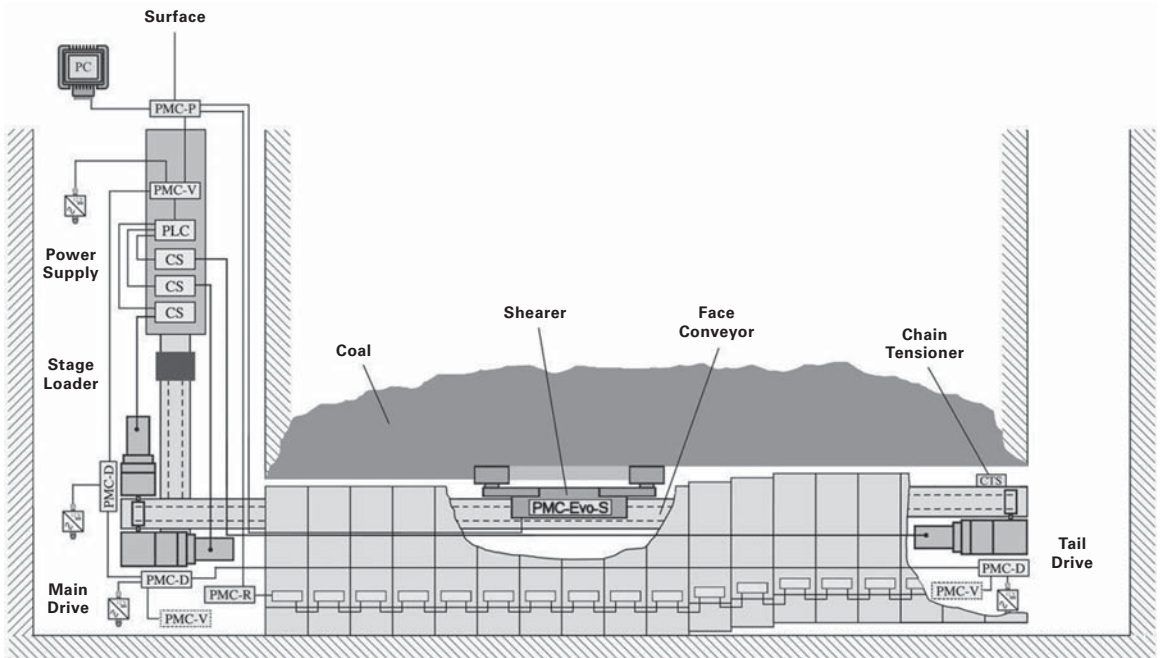

Together with the following peripheral equipment the PMC-R controller forms an individually per customer order designed control system for Longwall automation.

- Solenoid Driver Board (minimum one per Roof Support)
- Pressure Sensor
- Reed Rod
- Proximity Switch
- IR Transmitter and Sensor
- LED Warning Light
- IS Power Supply
- Diverse Data Coupler
- 3D-Tilt Sensor and 3D-Tilt Monitor
- Double Solenoid Valve

Such a PMC-R control system consists typically of more than a hundred similar subsystems set up by a PMC-R controller, solenoid driver, sensors, and valves per roof support and one time used hardware at the gate ends as server controllers, IPC, communication modules, chain tensioner, etc.

Main Features PMC-R Control System

- “Distributed Intelligence in each shield”
- Wide range of sensors and multiple solenoid drivers
- Easy diagnosis through communication between PMC-R controls
- Various auto sequences
- Automated conveyor push modes
- Conveyor pullback functions
- Automated water spray functions

- Outrigger steering for conveyor steering (mostly plow faces)
- Automation of:
 - Block anchorage
 - Flipper
 - Sliding canopy
 - Gap shield
 - Several steering cylinder automation modes dependent on roof conditions

Via a decentralized visualization and control unit at the face and/or the surface supports MineStar capabilities, especially HEALTH for Longwall.

The entire PMC-R system provides different global certifications:

- Europe: ATEX
- U.S.: MSHA
- Russia: EAC/Ex
- Australia: IECEx, ANZEx
- China: MA
- More certifications on demand

Solenoid Driver Module

The PMC-R solenoid driver module is placed at a distance from the PMC-R in accordance with the modular concept. The solenoid driver module can activate up to 22 valve functions, additional lights and sound modules or relays. As well, additional sensors could be read in by the solenoid driver module.

Solenoid Driver Module

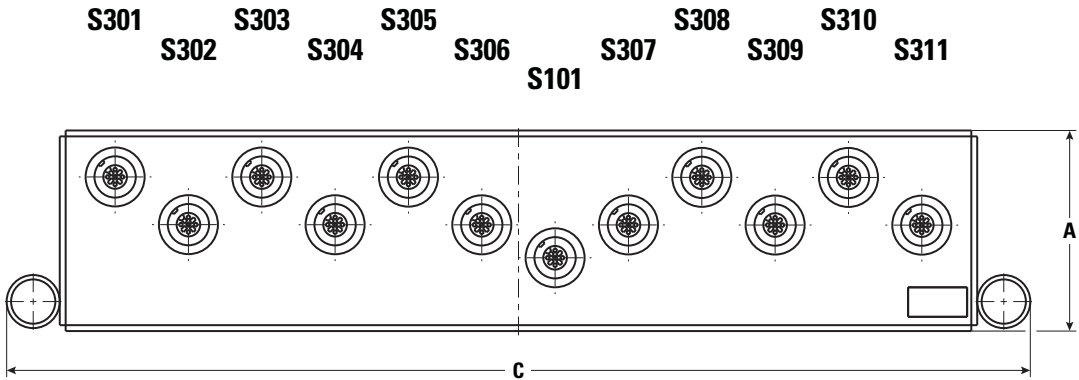
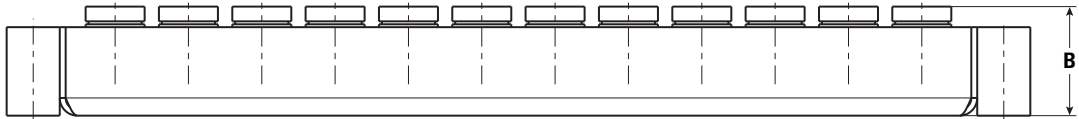

Dimensions (All dimensions are approximate.)

A	Width	68 mm	2.68"
B	Height	37 mm	1.46"
C	Length	347 mm	13.66"

PMC-D and PMC-V

Drive Control Unit and HMI (Human Machine Interface)

The intrinsically-safe PMC-D control is used on shearer or plow faces to provide high level AFC (armed face conveyor) and plow automation. Each Drive unit needs to be equipped with one PMC-D control unit and equivalent I/O to operate the CST drives or UEL gearbox functions.

The PMC-V provides in such a system the HMI to interact with the PMC-D controls to operate manual mode, visualize and change parameters and show actual process values. Within a PMC-D system minimum one and typically up to 3 PMC-Vs are in equal operation.

The PMC-D system can control extremely sensitive the speed and torque of highly powered AFC CST drive. Using Profibus network all PMC-Ds and PMC-Vs in a system could exchange process data over long distances with high frequency.

Attributes of PMC-D/PMC-D20 Control Unit

- Robust stainless steel design
- Highly reliable OS37 plug technology for complete gearbox control
- SKK24 hose cables for bus system and additional I/O connection
- IP 68 rating (48 h under @ 1 m [3.28 ft] under water)
- HMI with 24 multi feedback keys (pressure point, led light)
- 63.5 mm (2½") graphical monochrome display
- Multi language support
- Maintainability (brass bar mounting)
- Optional eight (8) additional ports for acceleration sensors (PMC-D20)

PMC-D

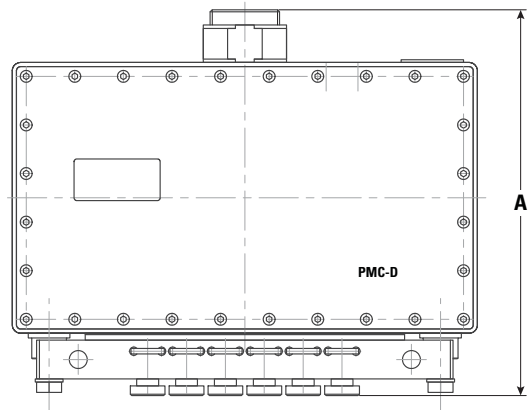
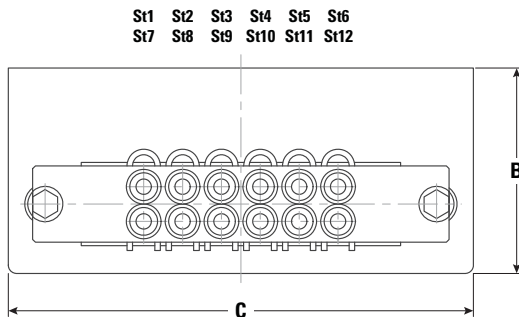

PMC-D Dimensions and Plug Assignments (All dimensions are approximate.)

A Width	278 mm	10.94"
B Height	148 mm	5.83"
C Length	335 mm	13.19"

PMC-D20

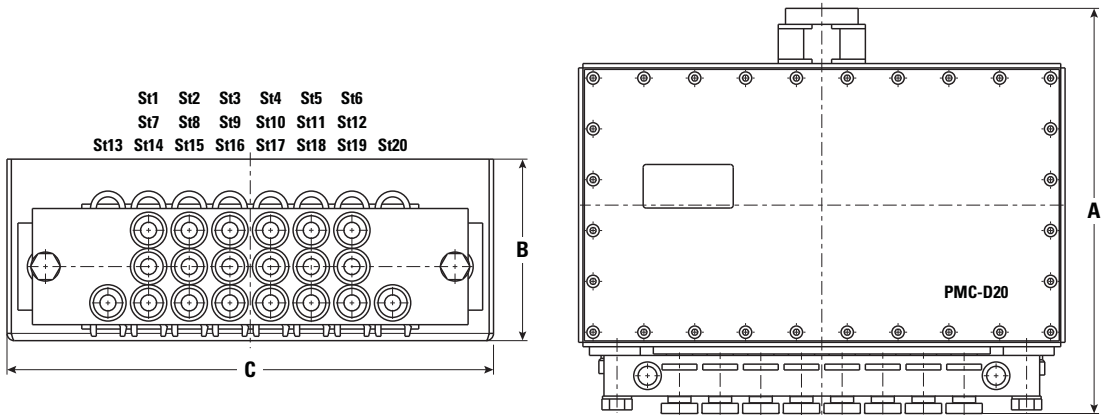

PMC-D20 Dimensions and Plug Assignments (All dimensions are approximate.)

A Width	279 mm	10.98"
B Height	125 mm	4.92"
C Length	335 mm	13.19"

PMC-V

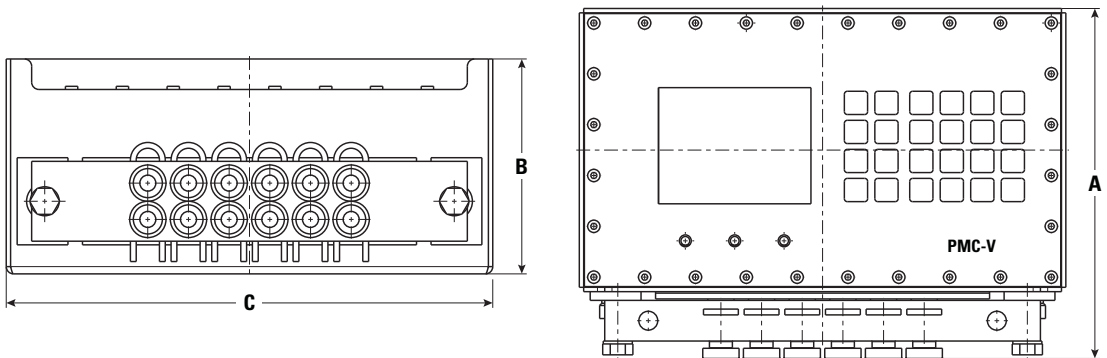

PMC-V Dimensions (All dimensions are approximate.)

A Width	241 mm	9.49"
B Height	148 mm	5.83"
C Length	335 mm	13.19"

Exemplarily System Layout of a PMC-D System (Plow Face)

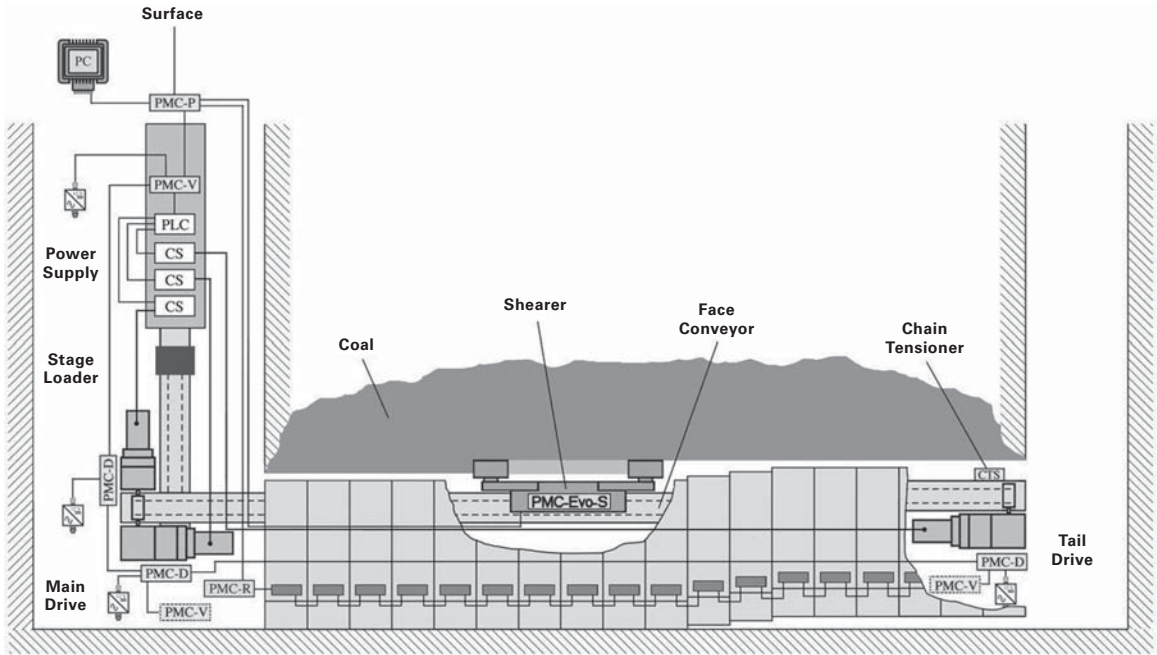

Main Features of the PMC-D Drive Control System

- “Distributed controller Intelligence per drive”
- Synchronized heavy load start up
- Soft startup
- Load sharing between conveyor drives
- Overload protection
- Motor braking feature
- Further used in plow operations:
 - Precise position detection
 - Overload protection

Additional Features

- Usage of PMC-D for chain tensioning of AFC (front and rear conveyor) and BSL
- In conjunction with Slacktronik® direct BLS chain slack control and relating chain tensioning
- Usage of PMC-D for high accurate plow position control and monitoring
- Support VFD controlled drive applications
- Optional integration of “HEALTH for Longwall Vibration Analysis” function with PMC-D20 control unit:
 - Acceleration sensor interface for eight (8) sensors
 - Integrated communication for vibration analysis

The entire PMC-D system provides different global certifications:

- Europe: ATEX
- U.S.: MSHA
- Russia: EAC/Ex
- Australia: IECEX, ANZEx
- China: MA
- More certifications on demand

Via a decentralized visualization and control unit at the face and/or the surface supports MineStar capabilities, especially HEALTH for Longwall.

HEALTH for Longwall Vibration Analysis

HEALTH for Longwall Vibration Analysis (former VibraGuard) provides vibration monitoring functionality for longterm health monitoring of the following longwall related equipment:

- CST gearbox and relating motor
- UEL gearbox and relating motor
- Stage loader gearbox and relating motor
- Crusher and relating motor
- Shearer haulage and ranging arm gearboxes
- Water/HFA pump station

MCU2

Main Control Unit

Application

- Visualization of all longwall data underground at gate end
- Change and control parameter from gate end
- Analysis of longwall system operation and situation
- Provide relevant process and HEALTH data to surface mine control room

Features

- Comprehensive software suite (HEALTH for Longwall) serving application software for Roof Support, AFC, Shearer and Plow
- Multi-language support:
 - English, German, Russian, Polish, Czech, Spanish, Chinese
- Robust IPC architecture for reliable operation in hazardous areas
- IS external keyboard with mouse function
- Robust design for sudden Methane face wide power off

Technical Data

Dimensions and Weight

Weight (approximate)	200 kg (441 lb)
Dimensions (approximate):	
Low support cabinet	630 × 945 × 450 mm (24.8 × 37.2 × 17.7 in)
High support cabinet	630 × 1145 × 450 mm (24.8 × 45.1 × 17.7 in)

Certifications and Identification

Certification	ATEX (within system: MA and GHOST)
Type of protection	I M2 EEx ib I
Temperature range	−20° C to +60° C (−4° F to +140° F)

Electrical Power Supply

- Power supply of the explosion-proof part, 110-240V AC
- Power supply of the intrinsically safe part, 12V DC, maximum 1.5A
- Non-intrinsically safe USB interface

Components

Processor	Intel i7 4 . 2.1 GHz
RAM memory	4 GB
Data memory	2 × 120 GB SSD
Hard drive	1 TB 6.4 cm (2.5 in)
Display	48.3 cm (19 in)
Resolution	1280:1024
Operating system	Windows 7
Input equipment keyboard with integrated mouse	

Intrinsically Safe Interfaces

- COM 1 BIDI SKK24
- COM 2 BIDI SKK24
- COM 3 BIDI SKK24
- COM 4 BIDI SKK24
- Ethernet via fiber-optic cable 9 μm

Drawings

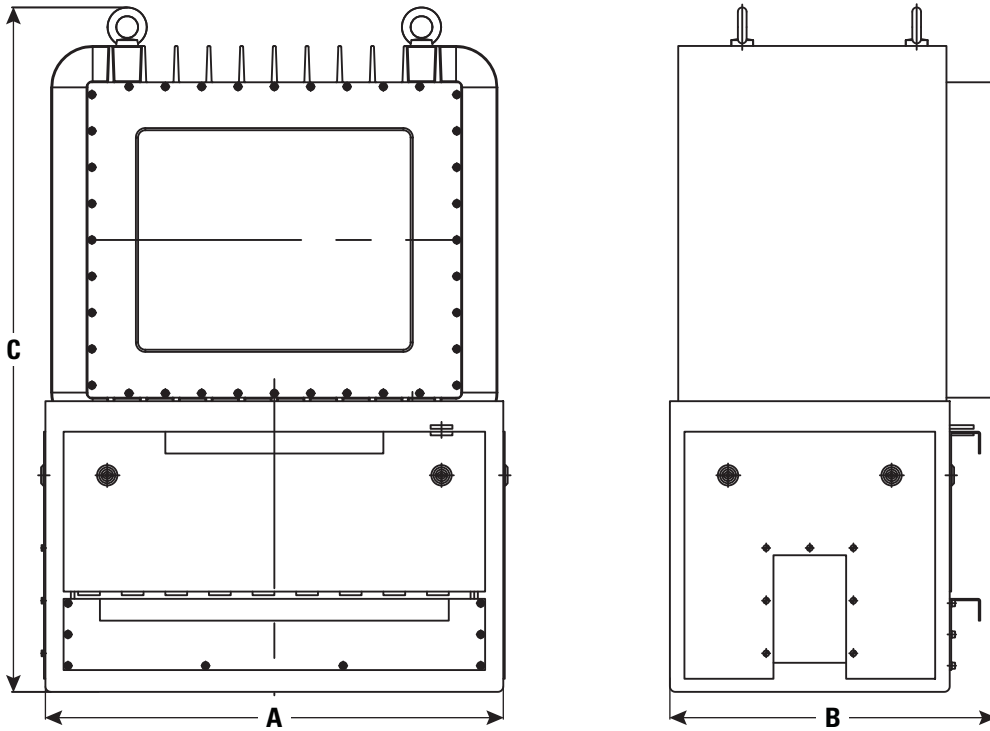

MCU2 Dimensions (All dimensions are approximate.)

A	Width	630 mm	24.80"
B	Height	450 mm	17.72"
C	Length	945 mm	37.20"

ROOF SUPPORT CARRIERS

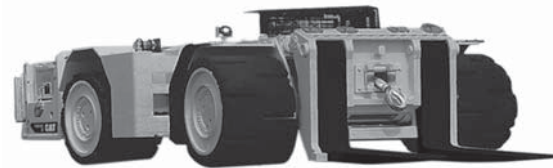
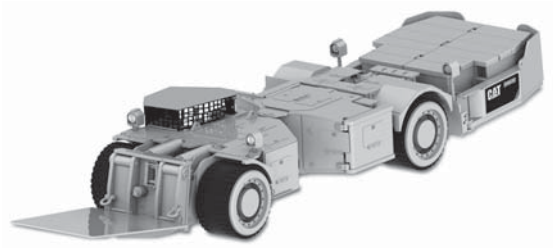

Features

Caterpillar leads the industry in offering customers the most comprehensive line of roof support carriers.

- Capacities from 20 tonnes to 80 tonnes (22 tons to 88 tons) — most often without the need to disassemble large components.
- Length and widths for a variety of entry constraints.
- Safety features that include operators canopy and cab protection, diesel control system, ground level battery access, emergency stops, spring-applied, hydraulic released brakes and optional canopy guarding.
- Diesel and battery powered options.
- Versatile fifth-wheel towing capability with the SH150 trailer.
- Front end work tool options.

MODEL	SH640		SH640B	
	3126		C7 ACERT*	
Engine Model				
Engine Power — Gross	171.5 kW	230 hp	171.5 kW	230 hp
Engine Power — Net	160 kW	216 hp	160 kW	216 hp
Tire Size	55 x 22 Solid		55 x 22 Solid	
Nominal Payload Capacity — Trimming	40 000 kg	88,160 lb	40 000 kg	88,160 lb
Machine Operating Weight, Forks Fitted	39 590 kg	87,281 lb	40 800 kg	89,950 lb
Length — Overall	9610 mm	378.3"	9610 mm	378.3"
— Wheelbase	3600 mm	141.7"	3600 mm	141.7"
Width — Overall	2600 mm	102.4"	2600 mm	102.4"
— Over Tires	2597 mm	102.2"	2597 mm	102.2"
Height — Lift Height to Top of Fork Tines	935 mm	36.8"	935 mm	36.8"
— Body	1610 mm	63.4"	1610 mm	63.4"
— Top of Canopy Adjustable High (loaded)	2030 mm	80"	2030 mm	80"
— Top of Canopy Adjustable Mid (loaded)	1970 mm	77.6"	1970 mm	77.6"
— Top of Canopy Adjustable Low (loaded)	1910 mm	75.2"	1910 mm	75.2"
— Ground Clearance (loaded)	360 mm	14.1"	360 mm	14.1"
Turning Radius — Outer with Forks	6510 mm	256.8"	6510 mm	256.8"
— Inner	3400 mm	133.9"	3400 mm	133.9"
Angle — Articulation		±42°		±42°
— Rear Axle Oscillation		±7°		±7°
— Maximum Fork Tilt Forward		23°		23°
— Maximum Fork Tilt Back		13°		13°
Hydraulic Cycle Time:				
Raise		9 Sec.		10 Sec.
Lower		8 Sec.		8 Sec.
Crowded Forward to Back		15 Sec.		16 Sec.
Travel Speeds:	km/h	mph	km/h	mph
Forward — 1st	3.3	2.1	2.9	1.8
— 2nd	6.3	3.9	6.1	3.8
— 3rd	10.6	6.6	10.5	6.5
— 4th	16.5	10.3	18.1	11.3
Reverse — 1st	3.3	2.1	2.9	1.8
— 2nd	6.3	3.9	6.1	3.8
— 3rd	10.6	6.6	10.5	6.5
— 4th	16.5	10.3	18.1	11.3
Tilt Force SAE	73 500 kg	161,994 lb	73 500 kg	161,994 lb
Lift Force SAE	42 700 kg	94,111 lb	42 700 kg	94,111 lb
Refill Capacity:				
Fuel	350 L	92.5 U.S. gal	350 L	92.5 U.S. gal
Hydraulic	450 L	118.9 U.S. gal	450 L	118.9 U.S. gal
Engine Crankcase with Filter	25 L	6.6 U.S. gal	25 L	6.6 U.S. gal
Transmission	40 L	10.6 U.S. gal	40 L	10.6 U.S. gal
Axle (each)	44.6 L	11.8 U.S. gal	44.6 L	11.8 U.S. gal
Drop Box		N/A	8 L	2.1 U.S. gal
Exhaust Conditioner/Water	450 L	118.9 U.S. gal	450 L	118.9 U.S. gal
Cooling System	72 L	19 U.S. gal	72 L	19 U.S. gal

*The 3126 meets U.S. EPA Tier 1, EU Stage I equivalent emission standards from the factory. The C7 ACERT engine meets U.S. EPA Tier 3, EU Stage IIIA, Japan 2006 (Tier 3) equivalent emission standards from the factory.
N/A = Not Available.

MODEL	SH660		SH660B	
	3126		C7 ACERT*	
Engine Model				
Engine Power — Gross	171.5 kW	230 hp	171.5 kW	230 hp
Engine Power — Net	160 kW	216 hp	160 kW	216 hp
Tire Size	54 x 28 Solid		54 x 28 Solid	
Nominal Payload Capacity — Trimming	60 000 kg	132,240 lb	60 000 kg	132,240 lb
Machine Operating Weight, Forks Fitted	59 200 kg	130,476 lb	59 200 kg	130,476 lb
Length — Overall	9940 mm	391.2"	9940 mm	391.2"
— Wheelbase	3620 mm	142.5"	3620 mm	142.5"
Width — Overall	3130 mm	129.1"	3130 mm	129.1"
— Over Tires	3100 mm	122"	3100 mm	122"
Height — Lift Height to Top of Fork Tines	670 mm	26.4"	670 mm	26.4"
— Body	1670 mm	65.7"	1670 mm	65.7"
— Top of Canopy Adjustable High (loaded)	2170 mm	85.4"	2170 mm	85.4"
— Top of Canopy Adjustable Mid (loaded)	2050 mm	80.7"	2050 mm	80.7"
— Top of Canopy Adjustable Low (loaded)	1980 mm	78"	1980 mm	78"
— Ground Clearance (loaded)	340 mm	13.4"	340 mm	13.4"
Turning Radius — Outer with Forks	6740 mm	265.4"	6740 mm	265.4"
— Inner	3120 mm	122.8"	3120 mm	122.8"
Angle — Articulation		±42°		±42°
— Rear Axle Oscillation		±7°		±7°
— Maximum Fork Tilt Forward		27°		27°
— Maximum Fork Tilt Back		16°		16°
Hydraulic Cycle Time:				
Raise		6 Sec.		8 Sec.
Lower		5 Sec.		7 Sec.
Crowded Forward to Back		10 Sec.		12 Sec.
Travel Speeds:	km/h	mph	km/h	mph
Forward — 1st	3.2	2.0	2.6	1.6
— 2nd	7.4	4.6	6.3	3.9
— 3rd	12.5	7.8	11.1	6.9
— 4th	20.5	12.7	19.5	12.1
Reverse — 1st	3.2	2.0	2.6	1.6
— 2nd	7.4	4.6	6.3	3.9
— 3rd	12.5	7.8	11.1	6.9
— 4th	20.5	12.7	19.5	12.1
Tilt Force SAE	102 700 kg	226,350 lb	102 700 kg	226,350 lb
Lift Force SAE	62 700 kg	138,190 lb	62 700 kg	138,190 lb
Refill Capacity:				
Fuel	370 L	97.7 U.S. gal	370 L	97.7 U.S. gal
Hydraulic	510 L	134.7 U.S. gal	510 L	134.7 U.S. gal
Engine Crankcase with Filter	25 L	6.6 U.S. gal	25 L	6.6 U.S. gal
Transmission	40 L	10.6 U.S. gal	40 L	10.6 U.S. gal
Axle (each)	69.5 L	18.4 U.S. gal	59.5 L	18.4 U.S. gal
Drop Box		N/A	8 L	2.1 U.S. gal
Exhaust Conditioner/Water	450 L	118.9 U.S. gal	450 L	118.9 U.S. gal
Cooling System	72 L	19 U.S. gal	72 L	19 U.S. gal

*The 3126 meets U.S. EPA Tier 1, EU Stage I equivalent emission standards from the factory. The C7 ACERT engine meets U.S. EPA Tier 3, EU Stage IIIA, Japan 2006 (Tier 3) equivalent emission standards from the factory.

N/A = Not Available.

Model	SH620		SH630	
Lift and Carry Capacity (Tire Dependent)	19.9 tonnes*	22 tons*	32.6 tonnes**	36 tons**
Machine Weight:				
less Battery	21 047 kg	46,400 lb	22 453 kg	49,500 lb
with 64SS125-21 Battery	28 123 kg	62,000 lb	—	—
with 64-125-25 Battery			33 566 kg	74,000 lb
with 64-125-25 Battery and Rear Ballast			36 287 kg	80,000 lb
Drive Train Tram Motors		2		2
Drive Train Tram Motor Power (each)	37.3 kW	50 hp	37.3 kW	50 hp
Tram Speed	8 km/h	5 mph		
Tram Speed Level and Empty — Zero Grade		—	5.79 km/h	3.6 mph
Tram Speed Level and Loaded — Zero Grade		—	5.14 km/h	3.2 mph
Hydraulic Pump Motor	11.9 kW	16 hp	11.9 kW	16 hp
Hydraulic Reservoir	189.3 L	50 U.S. gal	151.4 L	40 U.S. gal
Hydraulic PTO	8273 kPa	1200 psi	8273 kPa	1200 psi
Winch (2-Speed and Load Sensing)	15 900 kg/f	35,000 lbf	20 411.6 kg/f	45,000 lbf
Winch Cable Diameter	19 mm	$\frac{3}{4}$ "	25.4 mm	1"
Frame Oscillation — Total		20 degrees		40 degrees
Length:				
with 2083 mm (82") Lifting Forks	10 262 mm	33'8"	—	—
with 2134 mm (84") Lifting Forks		—	10 465 mm	34'4"
Width:				
with Attachments		—	2819 mm	9'3"
with Attachments and 965 mm (38") Tires	2845 mm	9'4"	—	—
with Attachments and 1118 mm (44") Tires	2897 mm	9'6"	—	—
Wheelbase	4953 mm	16'3"	4978 mm	16'4"
Cab Height:				
Standard Cab Adjustment with 965 mm (38") Tires	1321-1575 mm	52-62"	—	—
Standard Cab Adjustment with 1118 mm (44") Tires	1397-1651 mm	55-65"	—	—
508 mm (20") Cab with 1219 mm (48") Tires		—	1727 mm	68"
Turning Radius — Inside	4013 mm	13'2"	4139 mm	13'7"
Turning Radius — Outside	7061 mm	23'2"	7214 mm	23'8"

*With 1117.6 mm (**44"**) tires.

**With 48 x 22 solid tires.

Model	SH650		SH680	
Lift and Carry Capacity (Tire Dependent)	45.4 tonnes*	50 tons*	80 tonnes**	90 tons**
Machine Weight:				
less Battery	31 751 kg	70,000 lb	55 565 kg	122,500 lb
with 64-125-33, 200 Amp Hour Battery	46 039 kg	101,500 lb		
with 340 kW Hour Battery Pack	—		89 585 kg	197,500 lb
Drive Train Tram Motors		2		4
Drive Train Tram Motor Power (each)	37.3 kW	50 hp	74 kW	100 hp
Tram Speed Level and Empty — Zero Grade	5.1 km/h	3.2 mph	5.8 km/h	3.6 mph
Tram Speed Level and Loaded — Zero Grade	3.8 km/h	2.4 mph	5.8 km/h	3.6 mph
Hydraulic Pump Motor	11.9 kW	16 hp	75 kW	100 hp
Hydraulic Reservoir	189.3 L	50 U.S. gal	246 L	65 U.S. gal
Hydraulic PTO	17 581 kPa	2550 psi	17 581 kPa	2550 psi
Winch (2-Speed and Load Sensing)	31 751 kg/f	70,000 lbf	45 300 kgf***	100,000 lbf***
Winch Cable Diameter	22.2 mm	7/8"	35 mm	1 1/8"
Frame Oscillation — Total		40 degrees		20 degrees
Length:				
with 2134 mm (84") Lifting Forks	11 679 mm	38'4"	12 801 mm	42'0"
Width:				
with Attachments		—	3454 mm**	11'4"***
with Attachments and 1219 mm (48") Tires	2819 mm	9'3"		
with Attachments and 1371 mm (54") Tires	3021 mm	9'11"		
Wheelbase	5156 mm	16'11"	5486 mm	18'0"
Cab Height:				
Standard Cab Adjustments with 1219 mm (48") Tires	1448-1702 mm	57-67"		—
Standard Cabs with 1371 mm (54") Tires	1524-1778 mm	60-70"		—
Standard Cabs with 1397 mm (55") Tires		—	1778-2032 mm	70-80"
Turning Radius — Inside	4140 mm	13'7"	4140 mm	13'7"
Turning Radius — Outside	7214 mm	23'8"	7214 mm	23'8"

*With 54 x 26 solid tires.

**With 55 x 33 solid tires.

***Variable speed winch.

**SH640/SH640B
 TRACTIVE EFFORT vs. SPEED
 — LOADED**

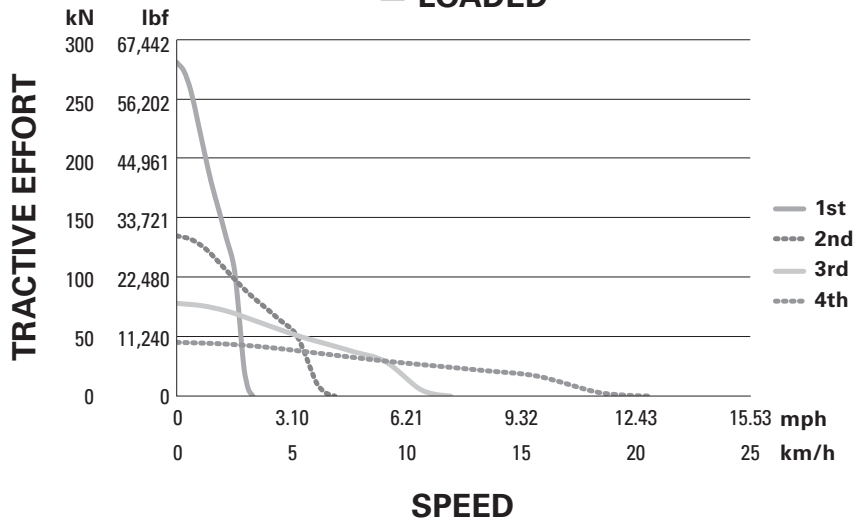

**SH660/SH660B
 TRACTIVE EFFORT vs. SPEED
 — LOADED**

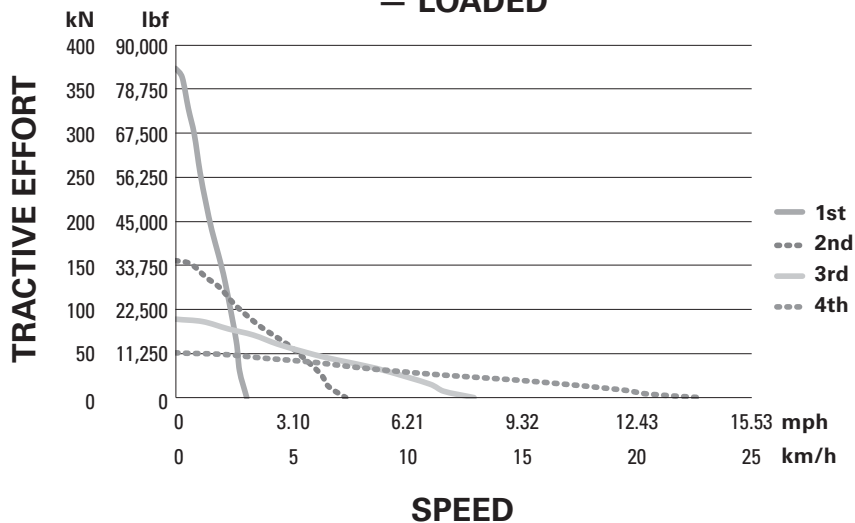

SH640/SH640B
% GRADE vs. SPEED — LOADED

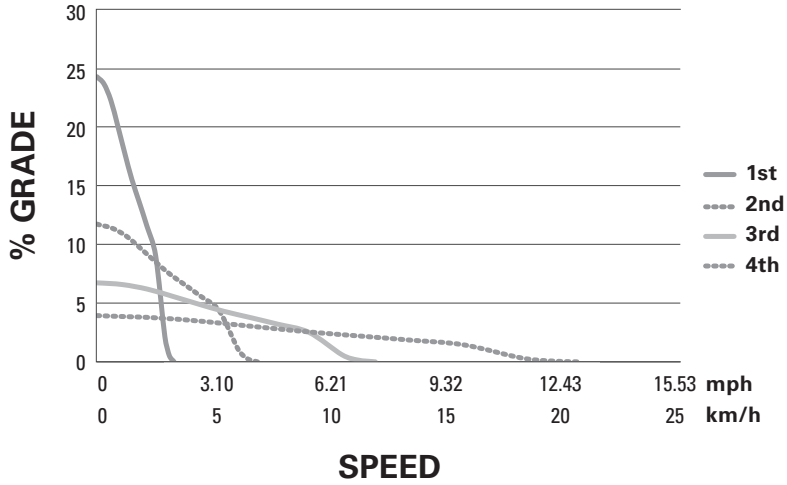

SH660/SH660B
% GRADE vs. SPEED — LOADED

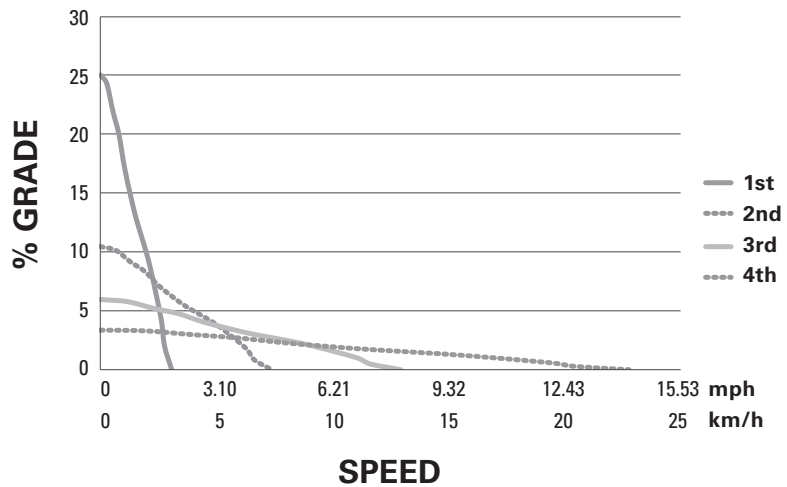

**SH640/SH640B
LIFT CAPABILITY**

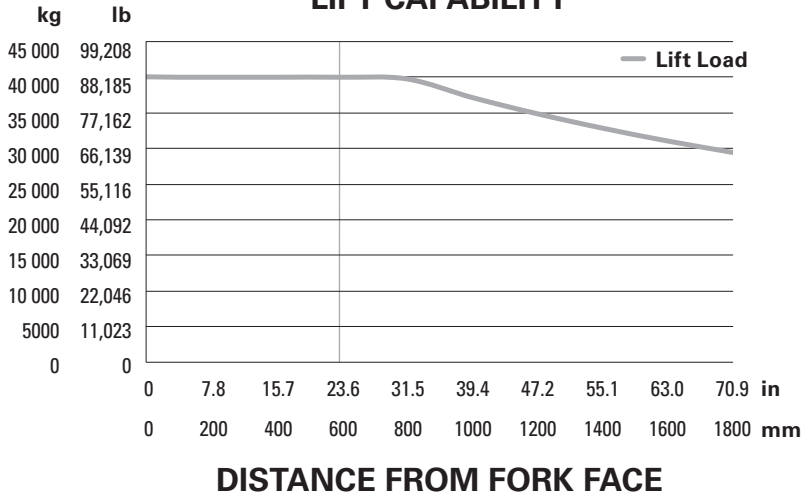

**SH660/SH660B
LIFT CAPABILITY**

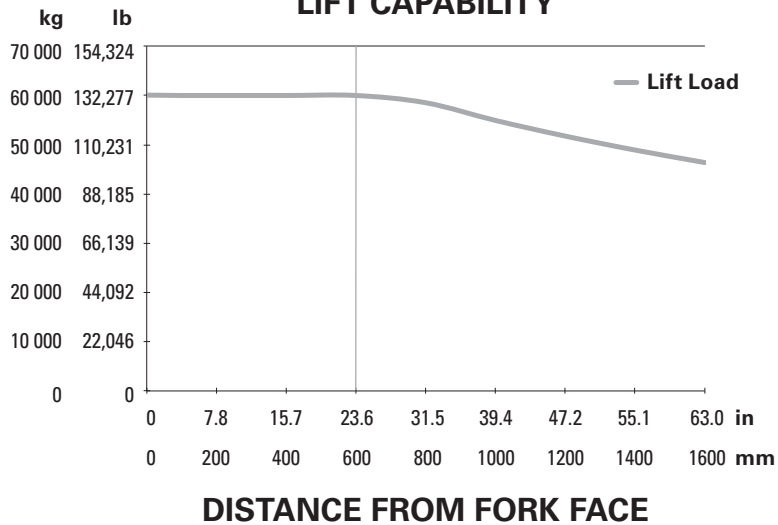

SHIELD TRAILERS



Features

When used in combination with the CL210 and CL215 LHD machines, the SH150 is the most cost-effective solution for mines that require versatile equipment able to perform multiple tasks. The SH150 shield trailer offers the following features:

- A fifth wheel connection attachment.
- Optional power assist for soft and inconsistent floor conditions.
- Hydraulic raise and lower to facilitate loading and unloading of the cargo.
- Ejection cylinders that facilitate unloading the trailer.
- Spring applied, hydraulic released brake.

MODEL	SH150		SH150 Power Assist	
Tractor Units	CL210 and CL215		CL210, CL215 and SH660	
Hydraulic Power Assist Option Traction Effort: Speed Unloaded	Reference machine spec 55 x 25 Soild		Up to 3 km/h (1.9 mph) in PA reference machine spec 55 x 25 Soild	
Tire Size				
Nominal Payload Capacity:				
CL210 Tractor	36 000 kg	79,366 lb	36 000 kg	79,366 lb
CL215 Tractor	50 000 kg	110,321 lb	55 000 kg	121,254 lb
SH660 Tractor	N/A		55 000 kg	121,254 lb
Winch Pull	30 000 kg	66,138 lb	30 000 kg	66,138 lb
Tare Machine Operating Weight	14 260 kg	31,437 lb	14 260 kg	31,437 lb
Length — Overall 1750 mm (68.9")	5760 mm	226.7"	5760 mm	226.7"
— Overall 2200 mm (86.6")	5600 mm	220.5"	5600 mm	220.5"
Width — Overall 1750 mm (68.9")	3430 mm	135"	3530 mm	139"
— Overall 2200 mm (86.6")	3880 mm	152.7"	3980 mm	153.1"
Height — Overall Raised	1835 mm	72.2"	1835 mm	72.2"
— Overall Lowered	1585 mm	62.4"	1585 mm	62.4"
— Ground Clearance Raised	250 mm	10"	250 mm	10"
Turning Radius — Outer	7480 mm	294.5"	7480 mm	294.5"
— Inner	3120 mm	122.8"	3120 mm	122.8"
Angle — Articulation	> 45°		> 45°	
Travel Speeds Loaded Power Assist:	km/h	mph	km/h	mph
Forward — 1st Gear				
CL210	N/A		3	1.9
CL215	N/A		4	2.5
SH660	N/A		3	1.9
Reverse — 1st Gear				
CL210	N/A		3	1.9
CL215	N/A		4	2.5
SH660	N/A		3	1.9
Refill Capacity:				
Axles	19.5 L	5.2 U.S. gal	19.5 L	5.2 U.S. gal

N/A = Not Available.

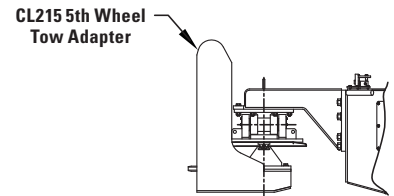
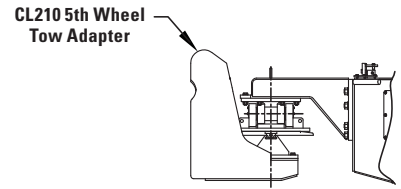
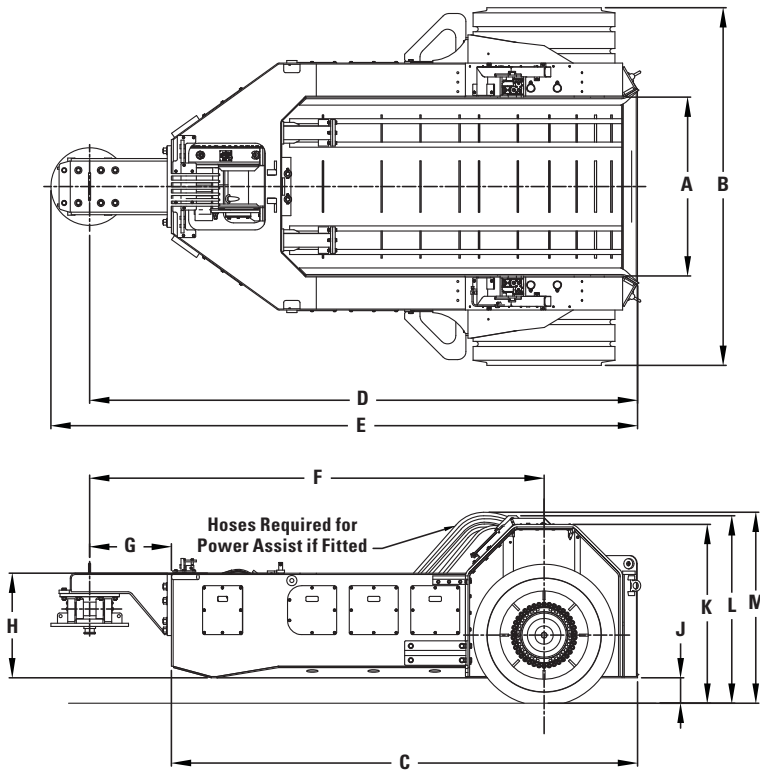

Dimensions (All dimensions are approximate.)

Trailer Model	Power Assist				Non-Power Assist			
	mm	in	mm	in	mm	in	mm	in
A Width – Inside	1750	68.9	2200	86.6	1750	68.9	2200	86.6
B Width – Overall Over Wheels	3530	139.0	3980	156.7	3430	135.0	3880	152.8
C Length – End to 5th Wheel Mount	4570	179.9	4420	174.0	4570	179.9	4420	174.0
D Length – End to 5th Wheel Pivot	5390	212.2	5220	205.5	5390	212.2	5220	205.5
E Length – Overall	5760	226.8	5600	220.5	5760	226.8	5600	220.5
F Length – Center of Wheel to 5th Wheel Pivot	4450	175.2	4300	169.3	4450	175.2	4300	169.3
G Length – 5th Wheel Stand Off	799	31.5	799	31.5	799	31.5	799	31.5
H Height – To Top of 5th Wheel Loaded	1024	40.3	1024	40.3	1024	40.3	1024	40.3
J Ground Clearance Lifted	250	9.8	250	9.8	250	9.8	250	9.8
K Height – To Top of Wheel Arch Lifted	1750	68.9	1750	68.9	1750	68.9	1750	68.9
L Height – To Top of Guard Lifted	1835	72.2	1835	72.2	1835	72.2	1835	72.2
M Height in Travel Position	1870	73.6	1870	73.6	1870	73.6	1870	73.6

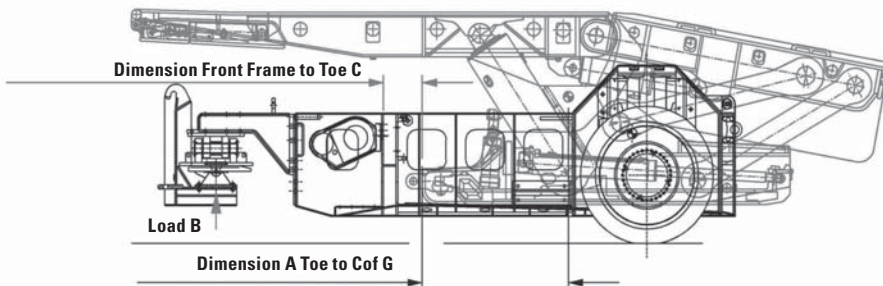

SH150 Load Setting Table

Distance inside frame to wheel centerline	2570 mm (101.2")
Standard distance 150 mm (5.9") offset to front frame.	2420 mm (95.3")
Distance wheel centerline to toe interference on frame	2340 mm (92.1")
Distance to the 560 mm (22") stop to wheel centerline.	2010 mm (79.1")
Distance 5th wheel centerline to wheel centerline	4451 mm (175.2")
Distance 5th wheel centerline trailer Cof G	3515 mm (138.5")
Standard weight of trailer and 5th wheel	15 tonnes (16.5 tons)
Load of standard trailer only on 5th wheel	3.2 tonnes (3.5 tons)
CL210 maximum rated load	10 tonnes (11 tons)
CL215 maximum rated load	15 tonnes (16.5 tons)

Distance Inside SH150 Frame Front to Toe "C"

Shield Weight	30 tonnes (33.1 tons)			
Distance Toe to CofG of Shield Dimension "A"	1300 mm (51.2")	1500 mm (59.1")	1700 mm (67")	1900 mm (74.8")
Load on "Fork" Rating "B" tonnes (tons)	7.94 tonnes (8.75 tons)	6.59 tonnes (7.26 tons)	5.24 tonnes (5.78 tons)	3.90 tonnes (4.30 tons)
Load at 5th with Toe on Standard Stops				
5 tonnes (5.5 tons)	996 mm (39.2")	796 mm (31.3")	596 mm (23.5")	396 mm (15.6")
8 tonnes (8.8 tons)	551 mm (21.7")	351 mm (13.8")	151 mm (5.9")	-49 mm (-1.9")
10 tonnes (11 tons)	254 mm (10")	54 mm (2.1")	-146 mm (-5.7")	-346 mm (-13.6")
12 tonnes (13.2 tons)	-42 mm (-1.7")	-242 mm (-9.5")	-442 mm (-17.1")	-642 mm (-25.3")
15 tonnes (16.5 tons)	-488 mm (-19.2")	-688 mm (-27.1")	-888 mm (-34.9")	-1088 mm (-42.8")
18 tonnes (19.8 tons)	-933 mm (-36.7")	-1133 mm (-44.6")	-1333 mm (-52.5")	-1533 mm (-60.4")

Shield Weight	35 tonnes (38.6 tons)			
Distance Toe to CofG of Shield Dimension "A"	1300 mm (51.2")	1500 mm (59.1")	1700 mm (67")	1900 mm (74.8")
Load on "Fork" Rating "B" tonnes (tons)	8.74 tonnes (9.63 tons)	7.16 tonnes (7.89 tons)	5.59 tonnes (6.16 tons)	4.02 tonnes (4.43 tons)
Load at 5th with Toe on Standard Stops				
5 tonnes (5.5 tons)	1035 mm (40.7")	835 mm (32.8")	635 mm (25")	435 mm (17.1")
8 tonnes (8.8 tons)	654 mm (25.7")	454 mm (17.8")	254 mm (10")	54 mm (2.1")
10 tonnes (11 tons)	399 mm (15.7")	199 mm (7.8")	-1 mm (-0.03")	-201 mm (-7.9")
12 tonnes (13.2 tons)	145 mm (5.7")	-55 mm (-2.2")	-255 mm (-10")	-455 mm (-17.9")
15 tonnes (16.5 tons)	-236 mm (-9.3")	-436 mm (-17.2")	-636 mm (-25")	-836 mm (-32.9")
18 tonnes (19.8 tons)	-618 mm (-24.3")	-818 mm (-32.2")	-1018 mm (-40.1")	-1218 mm (-47.9")

Shield will foul wall and or front	
Shield CofG too close to wheel	
Setting distance acceptable – please ensure maximum loads for the tractor are not exceeded	

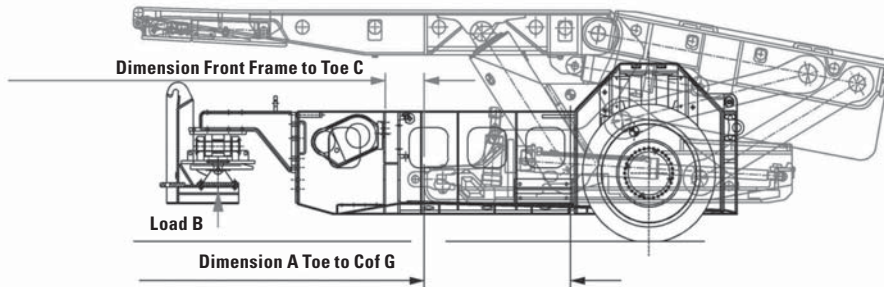

SH150 Load Setting Table

Distance inside frame to wheel centerline	2570 mm (101.2")
Standard distance 150 mm (5.9") offset to front frame.	2420 mm (95.3")
Distance wheel centerline to toe interference on frame	2340 mm (92.1")
Distance to the 560 mm (22") stop to wheel centerline.	2010 mm (79.1")
Distance 5th wheel centerline to wheel centerline	4451 mm (175.2")
Distance 5th wheel centerline trailer Cof G	3515 mm (138.5")
Standard weight of trailer and 5th wheel	15 tonnes (16.5 tons)
Load of standard trailer only on 5th wheel	3.2 tonnes (3.5 tons)
CL210 maximum rated load	10 tonnes (11 tons)
CL215 maximum rated load	15 tonnes (16.5 tons)

Distance Inside SH150 Frame Front to Toe "C"

Shield Weight	40 tonnes (44.1 tons)			
Distance Toe to CofG of Shield Dimension "A"	1300 mm (51.2")	1500 mm (59.1")	1700 mm (67")	1900 mm (74.8")
Load on "Fork" Rating "B" tonnes (tons)	9.53 tonnes (10.05 tons)	7.74 tonnes (8.53 tons)	5.94 tonnes (6.54 tons)	4.14 tonnes (4.56 tons)
Load at 5th with Toe on Standard Stops				
5 tonnes (5.5 tons)	1065 mm (41.9")	865 mm (34")	665 mm (26.2")	465 mm (18.3")
8 tonnes (8.8 tons)	731 mm (28.8")	531 mm (20.9")	331 mm (13")	131 mm (5.2")
10 tonnes (11 tons)	508 mm (20")	308 mm (12.1")	108 mm (4.3")	-92 mm (-3.6")
12 tonnes (13.2 tons)	286 mm (11.25")	86 mm (3.4")	-114 mm (-4.5")	-314 mm (-12.4")
15 tonnes (16.5 tons)	-48 mm (-1.9")	-248 mm (-9.8")	-448 mm (-17.6")	-648 mm (-25.5")
18 tonnes (19.8 tons)	-382 mm (-15")	-582 mm (-22.9")	-782 mm (-30.8")	-982 mm (-38.7")

Shield Weight	45 tonnes (49.6 tons)			
Distance Toe to CofG of Shield Dimension "A"	1300 mm (51.2")	1500 mm (59.1")	1700 mm (67")	1900 mm (74.8")
Load on "Fork" Rating "B" tonnes (tons)	10.33 tonnes (11.39 tons)	8.31 tonnes (9.16 tons)	6.29 tonnes (6.93 tons)	4.27 tonnes (4.71 tons)
Load at 5th with Toe on Standard Stops				
5 tonnes (5.5 tons)	1087 mm (42.8")	887 mm (34.9")	687 mm (27")	487 mm (19.2")
8 tonnes (8.8 tons)	791 mm (31.1")	591 mm (23.3")	391 mm (15.4")	191 mm (7.5")
10 tonnes (11 tons)	593 mm (23.3")	393 mm (15.5")	193 mm (7.6")	-7 mm (-0.3")
12 tonnes (13.2 tons)	395 mm (15.5")	195 mm (7.7")	-5 mm (-0.2")	-205 mm (-8.1")
15 tonnes (16.5 tons)	98 mm (3.9")	-102 mm (-4")	-302 mm (-11.9")	-502 mm (-19.8")
18 tonnes (19.8 tons)	-198 mm (-7.8")	-398 mm (-15.7")	-598 mm (-23.5")	-798 mm (-31.4")

Shield will foul wall and or front	
Shield CofG too close to wheel	
Setting distance acceptable – please ensure maximum loads for the tractor are not exceeded	

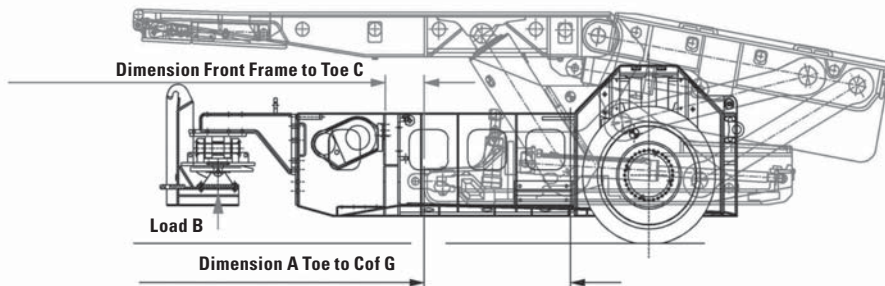

SH150 Load Setting Table

Distance inside frame to wheel centerline	2570 mm (101.2")
Standard distance 150 mm (5.9") offset to front frame.	2420 mm (95.3")
Distance wheel centerline to toe interference on frame	2340 mm (92.1")
Distance to the 560 mm (22") stop to wheel centerline.	2010 mm (79.1")
Distance 5th wheel centerline to wheel centerline	4451 mm (175.2")
Distance 5th wheel centerline trailer Cof G	3515 mm (138.5")
Standard weight of trailer and 5th wheel	15 tonnes (16.5 tons)
Load of standard trailer only on 5th wheel	3.2 tonnes (3.5 tons)
CL210 maximum rated load	10 tonnes (11 tons)
CL215 maximum rated load	15 tonnes (16.5 tons)

Distance Inside SH150 Frame Front to Toe "C"

Shield Weight	50 tonnes (55.1 tons)			
Distance Toe to CofG of Shield Dimension "A"	1300 mm (51.2")	1500 mm (59.1")	1700 mm (67")	1900 mm (74.8")
Load on "Fork" Rating "B" tonnes (tons)	11.13 tonnes (12.27 tons)	8.88 tonnes (9.79 tons)	6.64 tonnes (7.32 tons)	4.39 tonnes (4.84 tons)
Load at 5th with Toe on Standard Stops				
5 tonnes (5.5 tons)	1106 mm (43.5")	906 mm (35.7")	706 mm (27.8")	506 mm (19.9")
8 tonnes (8.8 tons)	839 mm (33")	639 mm (25.2")	439 mm (17.3")	239 mm (9.4")
10 tonnes (11 tons)	661 mm (26")	461 mm (18.1")	261 mm (10.3")	61 mm (2.4")
12 tonnes (13.2 tons)	483 mm (19")	283 mm (11.1")	83 mm (3.3")	-117 mm (-4.6")
15 tonnes (16.5 tons)	216 mm (8.5")	16 mm (0.6")	-185 mm (-7.3")	-385 mm (-15.2")
18 tonnes (19.8 tons)	-52 mm (-2")	-252 mm (-9.9")	-452 mm (-17.8")	-652 mm (-25.7")

Shield Weight	55 tonnes (60.6 tons)			
Distance Toe to CofG of Shield Dimension "A"	1300 mm (51.2")	1500 mm (59.1")	1700 mm (67")	1900 mm (74.8")
Load on "Fork" Rating "B" tonnes (tons)	11.93 tonnes (13.15 tons)	9.46 tonnes (10.43 tons)	6.98 tonnes (7.69 tons)	4.51 tonnes (4.97 tons)
Load at 5th with Toe on Standard Stops				
5 tonnes (5.5 tons)	1121 mm (44.1")	921 mm (36.3")	721 mm (28.4")	521 mm (20.5")
8 tonnes (8.8 tons)	878 mm (34.6")	678 mm (26.7")	478 mm (18.8")	278 mm (10.9")
10 tonnes (11 tons)	716 mm (28.2")	516 mm (20.3")	316 mm (12.4")	116 mm (4.6")
12 tonnes (13.2 tons)	554 mm (21.8")	354 mm (13.9")	154 mm (6.1")	-46 mm (-1.8")
15 tonnes (16.5 tons)	311 mm (12.2")	111 mm (4.4")	-89 mm (-3.5")	-289 mm (-11.8")
18 tonnes (19.8 tons)	69 mm (2.7")	-131 mm (-5.2")	-331 mm (-13")	-531 mm (-20.9")

Shield will foul wall and or front	
Shield CofG too close to wheel	
Setting distance acceptable – please ensure maximum loads for the tractor are not exceeded	

ROOM & PILLAR

Continuous Miners

Face Haulers

Continuous Haulage System

Feeder Breakers

Roof Bolter

Scoops

LHD Vehicles (Load-Haul-Dumps)

CONTENTS

ROOM & PILLAR

Introduction	20-121
Continuous Miners:	
Features	20-122
Specifications	20-123
Face Haulers:	
Features	20-126
Specifications	20-127
Dimensions	20-128
Continuous Haulage System:	
Features	20-129
Specifications	20-130
Dimensions	20-131
Feeder Breakers:	
Features	20-132
Specifications	20-133
Roof Bolter:	
Features	20-134
Specifications	20-135
Scoops:	
Features	20-136
Specifications	20-137
LHD Vehicles (Load-Haul-Dumps):	
Features	20-138
Specifications	20-139
Tractive Effort vs. Speed — Loaded	20-141
% Grade vs. Speed — Loaded	20-143
Lift Capability	20-145
Bucket Load Capacities	20-147

INTRODUCTION

Caterpillar is pleased to offer a comprehensive line up of underground room and pillar products that include continuous miners, haulage, roof bolters, and utility vehicles.

We manufacture these product lines in two locations; Houston, Pennsylvania and Beresfield, Australia. Both are Caterpillar facilities that adhere to the Cat Production System, dedicated to providing our customers with defect-free products of the highest quality.

We currently sell room and pillar products into applications that include coal extraction, gypsum, potash and salt production. In some cases, we purpose build the machine to work in these applications. For potash and very hard coal, we offer a tough cut version of our continuous miner, the CM445. For applications like potash that shy away from water use for dust control we offer oil cooled machines that limit water use. We can offer products that are suitable for both extremely low and tall seams.

For additional digital content for these products, including videos, virtual product tours and animations, please visit the product pages on www.cat.com.

CONTINUOUS MINERS



Features

Caterpillar offers a range of continuous miners that are capable of producing in seam heights as low as 762 mm (28") and as high as 4623 mm (182"). Industry leading power and performance are true across the product line, and in some cases, some products are available with tough cut options for extremely hard cutting. We sell this product line into coal, hard coal, phosphate, gypsum, salt, trona and potash applications.

- Minimum to maximum seam height options that range from 762 mm (28") to 4623 mm (182").
- Conveyor width and depth to max out the production capabilities of the cutter head with components that are designed for long life, reduced stretch and simple maintenance when needed.
- Crawlers that in some cases have new geometry to improve chain life and reduce stretch.
- Radio remote control with self diagnostic capabilities is standard.
- Motor ratings that support both U.S. (60 Hz) and international customers.
- AC tram option available on some models.
- Can be sold as part of a complete Cat system (including feeder breakers, roof bolters, haulage and scoops) supported by both local Cat Dealers and Cat Mining Finance.

MODEL	CM210		CM220	
Operating Dimensions:				
Mining Range (recommended)	914-1245 mm	36-49"	1067-2032 mm	42-80"
Minimum Height	762 mm	30"	914 mm	36"
Maximum Reach	1549 mm	61"	2337 mm	92"
Ground Clearance	152 mm	6"	229 mm	9"
Length Rear Bumper to Face	7849 mm	25'9"	7975 mm	26'2"
Transport Dimensions:				
Frame Width (over rub rails)	3175 mm	10'5"	3277 mm	10'9"
Overall Length	10 744 mm	35'3"	10 871 mm	35'8"
Height (over scrubber duct)	711 mm	28"	864 mm	34"
Weight (total)	45.4 tonnes	100,000 lb	56.7 tonnes	125,000 lb
Cutting Unit:				
Cutting Drum Diameter	762 mm	30"	813 mm	32"
Cutting Drum Width	3353 mm	11'0"	3505 mm	11'6"
Cutting Drum Power — Motors (one-hour rating)	2 × 149 kW	2 × 200 hp	2 × 149 kW	2 × 200 hp
Loading Unit:				
Loading Method	4 finger CLA*		6 finger CLA*	
Conveyor Width	762 mm	30"	914 mm	36"
Conveyor Depth	102 mm	4"	152 mm	6"
Loading Capacity	8-10 tonnes/min	9-11 tons/min	14-18 tonnes/min	15-20 tons/min
Conveyor Power — Motors (one-hour rating)	2 × 37 kW	2 × 50 hp	2 × 37 kW	2 × 50 hp
Traction Unit:				
Crawler Chain Width	508 mm	20"	508 mm	20"
Crawler Assembly Length	2921 mm	9'7"	2896 mm	9'6"
Ground Pressure	150 kPa	21.7 psi	189 kPa	27.4 psi
Crawler Speed	0-20 m/min	0-65 ft/min	0-26 m/min	0-85 ft/min
Traction Power — AC/VFD (one-hour rating)	2 × 82 kW	2 × 110 hp	2 × 82 kW	2 × 110 hp
Pump Unit:				
Pump Power — Motor (one-hour rating)	1 × 37 kW	1 × 50 hp	1 × 37 kW	1 × 50 hp
Dust Suppression:				
Scrubber Assembly	Top mounted		Top mounted	
Scrubber Type	Wet bed		Wet bed	
Scrubber Capacity	1.9 m³/sec	4000 ft³/min	2.8 m³/sec	6000 ft³/min
Fan Power — Motor	1 × 10 kW	1 × 13 hp	1 × 22 kW	1 × 30 hp
Electrical System:				
Machine Voltage (International voltages available)	950 VAC 60 Hz		950 VAC 60 Hz	
Control System	Processor based/radio remote control		Processor based/radio remote control	
Total Installed Power:				
One-hour Rating without Scrubber	575 kW	770 hp	575 kW	770 hp

*CLA denotes Continuous Loading Arms.

NOTE: These specifications are subject to change and may not reflect all options.

MODEL	CM230		CM240	
Operating Dimensions:				
Mining Range (recommended)	1270-2540 mm	50-100"	1676-3632 mm	66-143"
Minimum Height	1118 mm	44"	1530 mm	60"
Maximum Reach	2845 mm	112"	3931 mm	155"
Ground Clearance	229 mm	9"	305 mm	12"
Length Rear Bumper to Face	8153 mm	26'9"	8428 mm	27'8"
Transport Dimensions:				
Frame Width (over rub rails)	3277 mm	10'9"	3175 mm	10'5"
Overall Length	11 049 mm	36'3"	11 589 mm	38'0"
Height (over scrubber duct)	991 mm	39"	1137 mm	45"
Weight (total)	63.5 tonnes	140,000 lb	68 tonnes	150,000 lb
Cutting Unit:				
Cutting Drum Diameter	1118 mm	44"	1118 mm	44"
Cutting Drum Width	3531 mm	11'7"	3531 mm	11'7"
Cutting Drum Power — Motors (one-hour rating)	2 × 201 kW	2 × 270 hp	2 × 201 kW	2 × 270 hp
Loading Unit:				
Loading Method	6 finger CLA		3 finger CLA	
Conveyor Width	914 mm	36"	914 mm	36"
Conveyor Depth	152 mm	6"	305 mm	12"
Loading Capacity	18-23 tonnes/min	20-25 tons/min	18-23 tonnes/min	20-25 tons/min
Conveyor Power — Motors (one-hour rating)	2 × 37 kW	2 × 50 hp	2 × 45 kW	2 × 60 hp
Traction Unit:				
Crawler Chain Width	508 mm	20"	508 mm	20"
Crawler Assembly Length	2896 mm	9'6"	2896 mm	9'6"
Ground Pressure	212 kPa	30.7 psi	227 kPa	32.9 psi
Crawler Speed	0-26 m/min	0-85 ft/min	0-26 m/min	0-85 ft/min
Traction Power — AC/VFD (one-hour rating)	2 × 82 kW	2 × 110 hp	2 × 82 kW	2 × 110 hp
Pump Unit:				
Pump Power — Motor (one-hour rating)	1 × 37 kW	1 × 50 hp	1 × 37 kW	1 × 50 hp
Optional Dust Suppression:				
Scrubber Assembly	Top mounted		Top mounted	
Scrubber Type	Wet bed		Wet bed	
Scrubber Capacity	2.8 m³/sec	6000 ft³/min	3.8 m³/sec	8000 ft³/min
Fan Power — Motor	1 × 22 kW	1 × 30 hp	1 × 22 kW	1 × 30 hp
Electrical System:				
Machine Voltage (International voltages available)	950 VAC 60 Hz		950 VAC 60 Hz	
Control System	Processor based/radio remote control		Processor based/radio remote control	
Total Installed Power:				
One-hour Rating without Scrubber	680 kW	910 hp	694 kW	930 hp

MODEL	CM340		CM345N*		CM445	
Operating Dimensions:						
Mining Range (recommended)	1676-3810 mm	66-150"	2210-4318 mm	87-170"	1651-3480 mm	65-137"
Minimum Height	1524 mm	60"	2057 mm	81"	1499 mm	59"
Maximum Reach	4115 mm	162"	4623 mm	182"	3785 mm	149"
Ground Clearance	229 mm	9"	356 mm	14"	229 mm	9"
Length Rear Bumper to Face	8131 mm	26'8"	8204 mm	26'11"	8631 mm	28'4"
Transport Dimensions:						
Frame Width (over rub rails)	3483 mm	11'5"	3226 mm	10'7"	3424 mm	11'3"
Overall Length	11 009 mm	36'1"	11 252 mm	36'11"	11 530 mm	37'9"
Height (over scrubber duct)	1118 mm	44"	1651 mm	65"	—	—
Height (over cover line)	—	—	—	—	1394 mm	55"
Weight (total)	70.3 tonnes	155,000 lb	74.8 tonnes	165,000 lb	85.7 tonnes	189,000 lb
Cutting Unit:						
Cutting Drum Diameter	1118 mm	44"	1118 mm	44"	1118 mm	44"
Cutting Drum Width	3581 mm	11'9"	3581 mm	11'9"	3581 mm	11'9"
Cutting Drum Power — Motors (one-hour rating)	2 × 209 kW	2 × 280 hp	2 × 209 kW	2 × 280 hp	2 × 209 kW	2 × 280 hp
Loading Unit:						
Loading Method	3 finger CLA		3 finger CLA		3 finger CLA	
Conveyor Width	965 mm	38"	762 mm	30"	965 mm	38"
Conveyor Depth	305 mm	12"	305 mm	12"	305 mm	12"
Loading Capacity	14-35 tonnes/ min	15-39 tons/ min	14-35 tonnes/ min	15-39 tons/ min	14-35 tonnes/ min	15-39 tons/ min
Conveyor Power — Motors (one-hour rating)	2 × 48 kW	2 × 65 hp	2 × 48 kW	2 × 65 hp	2 × 48 kW	2 × 65 hp
Traction Unit:						
Crawler Chain Width	559 mm	22"	559 mm	22"	559 mm	22"
Crawler Assembly Length	2896 mm	9'6"	2896 mm	9'6"	3551 mm	11'8"
Ground Pressure	213 kPa	30.9 psi	227 kPa	32.9 psi	212 kPa	30.7 psi
Crawler Speed	0-26 m/min	0-85 ft/min	0-23 m/min	0-75 ft/min	0-23 m/min	0-75 ft/min
Traction Power — AC/VFD (one-hour rating)	—	—	2 × 82 kW	2 × 110 hp	2 × 82 kW	2 × 110 hp
Traction Power — DC Motors (one-hour rating)	2 × 56 kW	2 × 75 hp	—	—	—	—
Pump Unit:						
Pump Power — Motor (one-hour rating)	1 × 48 kW	1 × 65 hp	1 × 48 kW	1 × 65 hp	1 × 48 kW	1 × 65 hp
Optional Dust Suppression:						
Scrubber Assembly	Top mounted		Top mounted		Top mounted	
Scrubber Type	Wet bed		Wet bed		Wet bed	
Scrubber Capacity	3.8 m ³ / sec	8000 ft ³ / min	4.7 m ³ / sec	10,000 ft ³ / min	4.7 m ³ / sec	10,000 ft ³ / min
Fan Power — Motor	1 × 22 kW	1 × 30 hp	1 × 30 kW	1 × 40 hp	1 × 30 kW	1 × 40 hp
Electrical System:						
Machine Voltage (International voltages available)	995 VAC 60 Hz		995 VAC 60 Hz		995 VAC 60 Hz	
Control System	Processor based/ radio remote control		Processor based/ radio remote control		Processor based/ radio remote control	
Total Installed Power:						
One-hour Rating without Scrubber	675 kW	905 hp	727 kW	975 hp	727 kW	975 hp

*N denotes Narrow.

FACE HAULERS**Features**

Caterpillar offers and manufactures the FH120 face hauler from its Houston, Pennsylvania facility. The FH120 is a strong and proven product that is purpose built to withstand the hauling conditions and needs of underground mining. The FH120 Face Hauler offers:

- In by flexibility with battery power.
- A capacity of 17 tonnes (19 tons).
- Quick unloading cycles for fast turns.
- Maneuverability with “True Tracking” where the rear wheels follow in the same track left by the fronts.
- Ride quality improved by the use of accumulators to dampen shock loads.
- Modular design that makes service straight forward and provides greater accessibility.
- Efficient use of energy providing long battery discharge life.
- Safety features include tape-switch emergency stops, automatic emergency brakes, operator’s protective canopy, and dry-chemical fire suppression.

MODEL	FH120	
Empty Machine Weights:		
Empty Weight — less Battery	27 025 kg	59,580 lb
Empty Weight with 120-SSP110-19 Battery (237 kW hr/90 Amp hr)	37 566 kg	82,820 lb
Gross Vehicle Weights:	53 896 kg	118,820 lb
Gross Vehicle Weight with 120-SSP110-19 Battery 302 kW hr/1260 Amp hr	39 472 kg	87,020 lb
Design Gross Vehicle Weight	55 801 kg	123,020 lb
Maximum Load Capacity	16 329 kg	36,000 lb
Capacity (by Volume):		
Heaped with No Sideboards	18.5 m ³	653 ft³
Heaped with 5 cm (2") sideboards	19.2 m ³	678 ft³
Heaped with 10 cm (4") sideboards	19.8 m ³	702 ft³
Heaped with 15 cm (6") sideboards	20.5 m ³	726 ft³
Height:		
Minimum Canopy Height with 111 cm (44") Tires	129.5 cm	51"
Minimum Canopy Height with 127 cm (50") Tires	137 cm	54"
Length:		
Overall Length	1189 cm	39'0"
Overall Width (Widest Point)	365 cm	12'0"
Wheelbase	605 cm	19'0"
Ground Clearance:		
with 111 cm (44") Tires	25.4 cm	10"
with 127 cm (50") Tires	30.4 cm	12"
Turn Radius:		
Inside turn radius	348 cm	11'5"
Outside turn radius	757 cm	24'10"
Minimum Entry Width	510.5 cm	16'9"
Steering Articulation (Total)	120 degrees	
Tram Speed	0-9.6 km/h	0-6 mph
Discharge Time	24 seconds	
Terrain Compensation (Oscillation from Grade Changes)	15 degrees	
Machine Frame Articulation (Side to Side Movement)	10 degrees	
Power:		
Drive Assembly Motors	2 × 56 kW	2 × 75 hp
Hydraulic Pump Motor	1 × 36 kW	1 × 48 hp
Total Installed Power	148 kW	198 hp

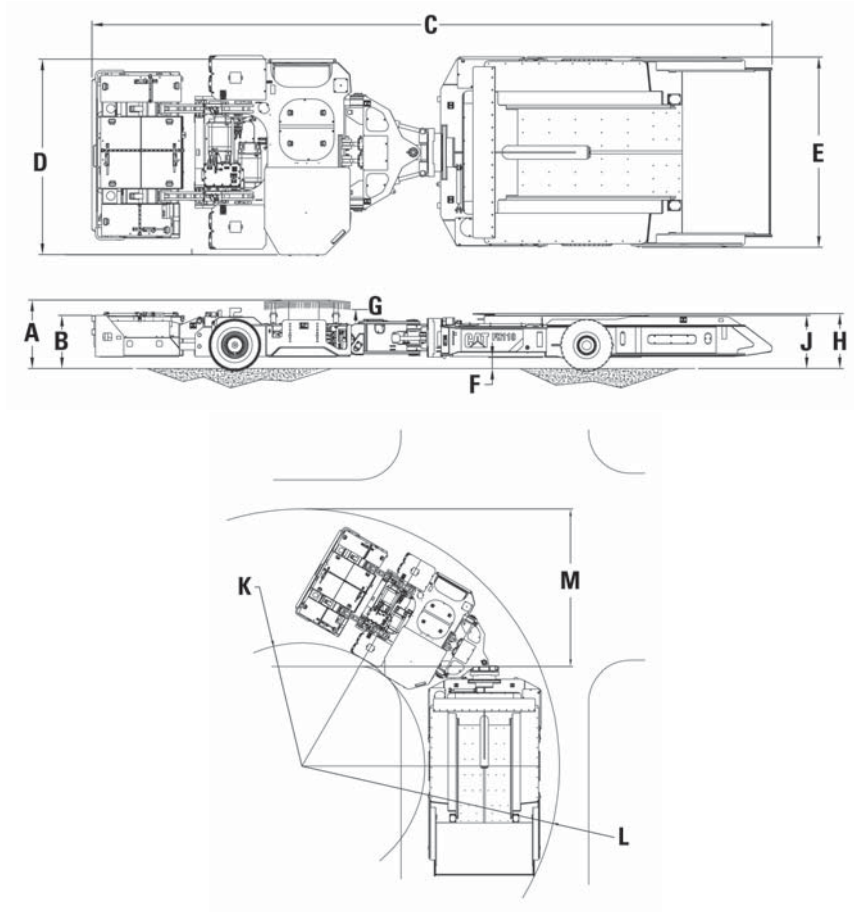

Dimensions (All dimensions are approximate.)

FH120

A Operating Height	1422-2133 mm	56-84"
B Frame Height	1168-1245 mm	46-49"
C Overall Length	11 880 mm	39'0"
D Width — Extended Deck	3610 mm	11'10"
E Trailer	3660 mm	12'0"
F Ground Clearance*	254 mm	10"
G Minimum Canopy Height*	1290 mm	51"
H Trailer Height at Top of False Bottom*	1245 mm	49"
J Trailer Frame Height*	1168 mm	46"
K Inside Turning Radius	3.48 m	11'5"
L Outside Turning Radius	7.57 m	24'10"
M Minimum Entry Width	4.75 m	15'7"

*FH120 with 44" tires.

CONTINUOUS HAULAGE SYSTEM

Continuous Haulage can be tailored for your specific projection, and can be easily installed in new or existing operations. They are as reliable and trouble-free as any piece of face equipment available today.



Features

- Up to 18 tonne-per minute (20 ton-per-minute) capacity.
- Attached or detached systems (with hopper).
- 0.8 m (30 in) conveyor width.
- Internal gear-driven crawler drive assemblies.
- Forged 0.4 m (14 in) crawlers are designed to provide a balance between tractive ability and yet maintain low ground pressures in soft conditions.
- Available with an optional feeder breaker to size material.
- On board electronics provide diagnosis capability on over 400 events — operators get both a code and words to describe the event.
- Optional spray manifolds can be added for dust control.
- Safety features include “man in position” sensors, operators protective canopy, and e-stops.
- Remote grease points are easily accessible.
- Lighting for excellent work area visibility.
- Chromium carbide overlay plate is used on the conveyor to control wear and provide long service life.
- Torque limiter couplings on conveyor drives protect against spikes and chain breakage.
- Simple hydraulic system with excellent filtration to maintain performance.

MODEL	FH330	
Optimal Seam Heights	914-1270 mm	36-50"
Weights:		
Mobil Bridge Carrier Empty	18 144 kg	40,000 lb
With Bridge Attached at Each End	27 216 kg	60,000 lb
Bridge Empty Weight	9072 kg	20,000 lb
Power:		
Total Installed — Standard	100 kW	135 hp
Conveyor Drive Motor — Standard	2 × 22 kW	2 × 30 hp
Conveyor Drive Motor — Low Profile Outby	1 × 30 kW	1 × 40 hp
Tram Motor	1 × 56 kW	1 × 75 hp
Capacity (Throughput)	18 tonnes/min 816 tonnes/hr	20 tons/min 900 tons/hr
Conveyor:		
Chain Speed	91 m/min	300 ft/min
Flight Spacing	406 mm	16"
Conveyor Chain Take Up	Grease with manual shim locks	
Width	762 mm	30"
Deck	Chromium carbide overlay	
Bridge Carrier Sideboards	76 mm	3"
Ground Pressure:		
Empty	124 kPa	18 psi
Loaded	179 kPa	26 psi
Crawler Take Up	Grease with manual shim locks	
Bridges (Pigs):		
Length Option 1	914 cm	30'0"
Length Option 2	1189 cm	39'0"
Sideboard Option	76 mm	3"

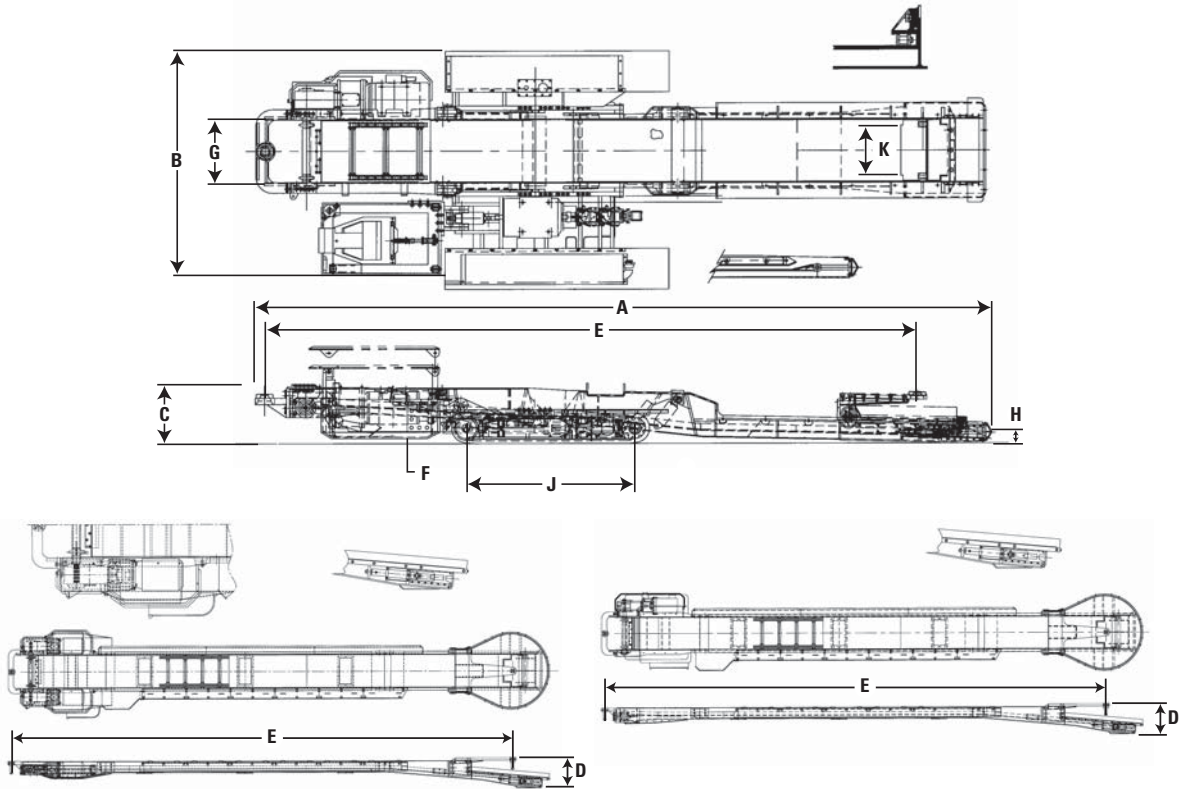

Dimensions — FH330 (All dimensions are approximate.)

	Bridge Carrier		Bridge		Bridge — Low Profile Outby	
	mm	ft-in	mm	ft-in	mm	ft-in
A Overall Length	8839	29'0"	11 887	39'0"	11 887	39'0"
	—	—	126 489	41'6"	12 649	41'6"
B Overall Width	2896	9'6"	9144	30'0"	9144	30'0"
	—	—	9906	32'6"	9906	32'6"
C Overall Height	711	28"	1905	6'3"	1829	6'0"
D Stack-up Height (over bridge without sideboards)			711	28"	711	28"
Discharge End	711	28"	—	—	—	—
Receiving End	711	28"	—	—	—	—
E Length, Mine Reach (pivot to pivot)	7925	26'0"	11 887	39'0"	11 887	39'0"
	—	—	9144	30'0"	9144	30'0"
F Ground Clearance	152	6"	—	—	—	—
G Conveyor Width	762	30"	762	30"	762	30"
H Conveyor Depth	152-254	6-10"	152	6"	152	6"
J Crawler Length (center to center)	2045	80.5"	—	—	—	—
K Crawler Width	356	14"	—	—	—	—
Swing	—	—	90 degrees		90 degrees	

FEEDER BREAKERS

More than 1000 Cat feeder breakers are enabling productivity and profitability on mine sites around the world. Heavy-duty frame construction, high tractive effort and the ability to have the tail piece integrated into the main frame make our feeder breakers the perfect fit for longwall development sections.

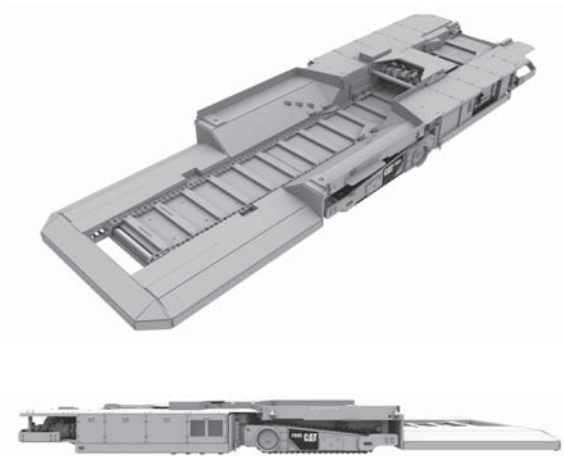

Features

- Mid and High Seam options available.
- High pick forces and processing rates make these very productive machines.
- Unique spiral-pick breaker bar for hard rock and pyrite balls.
- Heavy duty crawler design providing stability and tractive effort.
- Mechanical conveyor drive standard with optional hydraulic drive available.
- Chrome carbide overlay on conveyor pans for extra long life and wear resistance.
- Torque limiting on conveyor to safeguard against torque spikes and stoppages caused by debris.
- Multiple intake configurations to fit face haulage equipment.

MODEL	FB110		FB140	
Measurements:				
Overall Width	3.30 m	11'2"	3.38 m	11'1"
Receiving End Width	3.27 m	10'9"	3.35 m	11'0"
Conveyor Width	1.42 m	56"	1.42 m	56"
Overall Length	10.26 m	33'8"	10.67 m	35'0"
Breaker Tip to Tip Diameter	635 mm	25"	635 mm, 686 mm, 813 mm	25", 27", 32"
Ground Clearance — Receiving End	25-331 mm	1-13"	181-501 mm	7-19"
Ground Clearance — Discharge End	533-795 mm	21-31"	587-1034 mm	23-40¾"
Frame Height Fixed	1011 mm	40"	940-1448 mm	37-57"
Total Power	150 kW	200 hp	260 kW	350 hp
Tractive Effort	16 163 kg	35,634 lb	56 700 kg	125,000 lb
Tram Speed (Variable)	0-13.7 m/min	0-45 ft/min	0-13.7 m/min	0-45 ft/min
Ground Pressure	21 445 kg/m ²	30.5 psi	—	—
Maximum Grade Capability		15%		15%
Gross Vehicle Weight	31 752 kg	70,000 lb	29 483-49 895 kg	75,000-110,000 lb
Seam Height Capability	1219-1524 mm	48-60"	1371 mm and higher	54" and higher
Material Throughput	1146 tonnes/hr	1263 tons/hr	1385 tonnes/hr	1526 tons/hr
Breaker Pick Force (Variable)	46 720 kg	103,000 lb	60 000 kg	130,000 lb
Material Compressive Strength	161 Mpa	18,000 psi	200 Mpa	30,000 psi

ROOF BOLTER

Caterpillar offers a single roof bolter model, the RB220. This dual boom model is a proven, hard working and well designed product that's simple to operate, simple to maintain and will provide many years of service.

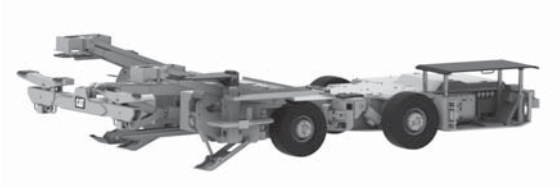
**Features**

- Articulated steering for maneuvering.
- Both horizontal and vertical articulation on this dual boom model.
- Floor and roof avoidance compensation.
- Individual planetary wheel drives — no sprockets or chains.
- User-friendly operator zones.
- Single AC primary drive motor.
- Single hydraulic oil pump.
- Easy access components.
- Quick free-steering towing conversion.
- Streamlined, practical space-planned tram station.
- Safety features include ATRS system, tape-switch emergency stops, automatic emergency brakes, operator's protective canopy, and dry-chemical fire suppression.

MODEL	RB220	
Overall Length with ATRS	7671 mm	25'2"
Chassis Overall Width	2756 mm	9'0.5"
Drill Boom Feed	2337 mm	4'4"
Minimum Trimming Height:		
with 28x12-15 Tires	813 mm	2'8"
with 32x12.5-15 Tires	965 mm	3'2"
with 35x15-15 Tires	1003 mm	3'3.5"
ATRS Reach:		
with 28x12-15 Tires	2438 mm	8'0"
with 32x12.5-15 Tires	2438 mm	8'0"
with 35x15-15 Tires	2438 mm	8'0"
Ground Clearance:		
with 28x12-15 Tires	150 mm	6"
with 32x12.5-15 Tires	203 mm	8"
with 35x15-15 Tires	241 mm	9.5"
Chassis Height:		
with 28x12-15 Tires	686 mm	2'3"
with 32x12.5-15 Tires	737 mm	2'5"
with 35x15-15 Tires	775 mm	2'6.5"
Wheelbase	2007 mm	6'7"
Tram Speed:		
Fast	2.38 m/sec	0-130 ft/min
Slow	1.19 m/sec	0-65 ft/min
Drilling Feed Thrust (maximum)	4536 kg	10,000 lb
Drilling Torque (variable)	420 N·m	310 lbf-ft
Bolt Tightening Torque (adjustable)	258 N·m	190 lbf-ft
Steering Articulation Total		80 degrees
Inside Turning Radius	2.9 m	9'6"
Outside Turning Radius	6.5 m	21'6"

SCOOPS

With over 40 years of experience and over 6500 battery-powered units produced, Cat scoops are leaders in the industry. These products set the bar for efficient and reliable underground utility vehicles. The SU488 is one of the strongest and most rugged low-profile scoops ever built.

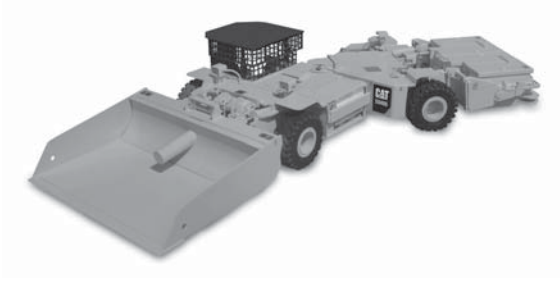

Features

- Oversize center sections for long life and reliability.
- Safety features include tape-switch emergency stops, automatic emergency brakes, operator's protective canopy, and dry-chemical fire suppression.
- Wet-disc service brakes.
- Proprietary IGBT electric controllers.
- Multi-purpose contoured bottom bucket.
- Planetary wheel drives.
- Ground-level battery change system.
- Optional AC traction.

MODEL	SU488		SU488 D		SU488 L	
Overall Length with Contoured Bucket	8940 mm	29'4"	9880 mm	32'5"	8760 mm	28'9"
Overall Width with Contoured Bucket	2900 mm	9'6"	2920 mm	9'7"	2920 mm	9'7"
Wheelbase	3660 mm	12'0"	3860 mm	12'8"	3710 mm	12'2"
Un-A-Trac Empty Weights — Less Battery	16 650 kg	36,700 lb	—	—	—	—
Scoop Utility Empty Weights Less Battery	—	—	22 680 kg	50,000 lb	—	—
Ground Clearance:					12 700 kg	28,000 lb
with 28x15-15 Tires	—	—	—	—	200 mm	8"
with 32x15-15 Tires	—	—	—	—	240 mm	9.5"
with 35x15-15 Tires	250 mm	10"	267 mm	10.5"	280 mm	11"
with 38x16-15 Tires	330 mm	13"	267 mm	10.5"	—	—
with 44x18-20 Tires	—	—	267 mm	10.5"	—	—
Adjustable Cab Height:						
with 28x15-15 Tires	—	—	—	—	1120 mm	44"
with 32x15-15 Tires	—	—	—	—	1155 mm	45.5"
with 35x15-15 Tires	1270- 1520 mm	4'2"-5'0"	1257 mm	4'1.5"	1190 mm	47"
with 38x16-15 Tires	1350- 1600 mm	4'5"-5'3"	1295 mm	4'3"	—	—
with 44x18-20 Tires	—	—	1372 mm	4'6"	—	—
Main Frame Height:						
with 28x15-15 Tires	—	—	—	—	710 mm	28"
with 32x15-15 Tires	—	—	—	—	760 mm	30"
with 35x15-15 Tires	860 mm	2'10"	978 mm	3'2.5"	800 mm	31.5"
with 38x16-15 Tires	940 mm	3'1"	1016 mm	3'4"	—	—
with 44x18-20 Tires	—	—	1092 mm	3'7"	—	—
Inside Turn Radius	3660 mm	12'0"	3660 mm	12'0"	3660 mm	12'0"
Outside Turn Radius	7315 mm	24'0"	8940 mm	29'4"	7315 mm	24'0"
Steering Articulation	80° total		80°		80° total	
Lift and Carry Capacity:						
at 914 mm (36") from the Face of Lift Plate	14.5 tonnes	16 tons	14.5 tonnes	16 tons	—	—
at 1220 mm (48") from Bucket Mounting Pin	—	—	—	—	9.1 tonnes	10 tons

LHD VEHICLES (LOAD-HAUL-DUMPS)**Features**

Cat Load Haul Dump machines are equipped to handle all types of utility work in close, underground applications. With work tool versatility and quick disconnect and rapid attachment features, work gets done quickly and efficiently.

With three diesel powered models to choose from, your utility needs can be met with options that include wet or dry type exhaust systems, heavy duty axles, and varying lift and power capabilities.

- Rapid Attachments System (RAS).
- Turbocharged, aftercooled, diesel engine with 4-speed transmission with manual or electronic push-button powershift with forward/reverse mode.
- Wet bath or dry type exhaust system with diesel particulate filtration.
- Optional OEM heavy-duty axles with spring applied, hydraulically released brakes.

MODEL	CL210		CL210B	
	3126*		C7 ACERT**	
Engine Model				
Engine Power — Gross	170 kW	230 hp	171.5 kW	230 hp
Engine Power — Net	154 kW	208 hp	160 kW	216 hp
Tire Size	17.5 R25 L3		17.5 R25 L3	
Nominal Payload Capacity — Trimming	10 000 kg	22,040 lb	10 000 kg	22,040 lb
Nominal Payload Capacity — Truck Loading	10 000 kg	22,040 lb	10 000 kg	22,040 lb
Machine Operating Weight without Tools	22 170 kg	48,862 lb	22 300 kg	49,150 lb
Bucket Size — Heaped Capacity (SAE)	3.5 m ³	4.6 yd³	3.5 m ³	4.6 yd³
Bucket Size — Struck Capacity	2.7 m ³	3.5 yd³	2.7 m ³	3.5 yd³
Length — Overall Spade Bucket	9605 mm	378.1"	9620 mm	378.7"
— Overall Forks	9635 mm	379.3"	9650 mm	379.9"
— Wheelbase	3360 mm	132.3"	3360 mm	132.3"
Width — Overall with Bucket	2500 mm	98.4"	2500 mm	98.4"
— Overall without Bucket	2300 mm	90.5"	2340 mm	92.1"
— Over Tires	2310 mm	91"	2310 mm	91"
Height — Overall Bucket Raised	3730 mm	147"	3730 mm	147"
— Overall to Top of Forks Tine	2490 mm	98"	2490 mm	98"
— Body	1590 mm	62.6"	1550 mm	61"
— Top of Canopy Adjustable High	1990 mm	78.3"	1990 mm	78.3"
— Top of Canopy Adjustable Mid	1927 mm	75.9"	1927 mm	75.9"
— Top of Canopy Adjustable Low	1864 mm	73.4"	1864 mm	73.4"
— Ground Clearance	370 mm	15.4"	370 mm	15.4"
Turning Radius — Outer with Bucket	6310 mm	248.4"	6300 mm	248"
— Inner	3110 mm	122.4"	3110 mm	122.4"
Angle — Articulation		±43°		±43°
— Rear Axle Oscillation		±7.5°		±7.5°
— Maximum Bucket Dump Parallel Lift		17°		17°
Hydraulic Cycle Time:				
Raise		8 Sec.		8 Sec.
Dump		5 Sec.		5 Sec.
Lower		6 Sec.		6 Sec.
Total		19 Sec.		19 Sec.
Travel Speeds:	km/h	mph	km/h	mph
Forward — 1st	3.8	2.3	2.9	1.8
— 2nd	7.8	4.8	6.1	3.8
— 3rd	13.6	8.5	10.5	6.5
— 4th	23.4	14.5	18.1	11.3
Reverse — 1st	3.8	2.3	2.9	1.8
— 2nd	7.8	4.8	6.1	3.8
— 3rd	13.6	8.5	10.5	6.5
— 4th	23.4	14.5	18.1	11.3
Tilt Breakout Force (SAE)	10 000 kg	22,040 lb	10 000 kg	22,040 lb
Lift Breakout Force (SAE)	10 000 kg	22,040 lb	10 000 kg	22,040 lb
Refill Capacity:				
Fuel	200 L	53 U.S. gal	200 L	53 U.S. gal
Hydraulic	250 L	66 U.S. gal	250 L	66 U.S. gal
Engine Crankcase with Filter	22 L	5.8 U.S. gal	25 L	6.6 U.S. gal
Transmission	40 L	10.6 U.S. gal	40 L	10.6 U.S. gal
Axles	60 L	15.9 U.S. gal	60 L	15.9 U.S. gal
Drop Box	8 L	2.1 U.S. gal	8 L	2.1 U.S. gal
Exhaust Conditioner/Water	450 L	118.9 U.S. gal	450 L	118.9 U.S. gal
Cooling System	72 L	19 U.S. gal	72 L	19 U.S. gal

*The 3126 meets U.S. EPA Tier 1, EU Stage I equivalent emission standards.

**The C7 ACERT engine meets U.S. EPA Tier 3, EU Stage IIIA, Japan 2006 (Tier 3) equivalent emission standards.

MODEL	CL215	
Engine Model		3126*
Engine Power — Gross	170 kW	230 hp
Engine Power — Net	154 kW	208 hp
Tire Size		20.5 R25 L3
Nominal Payload Capacity — Trimming	15 000 kg	33,060 lb
Nominal Payload Capacity — Truck Loading	15 000 kg	33,060 lb
Machine Operating Weight without Tools	26 500 kg	48,406 lb
Bucket Size — Heaped Capacity (SAE)	4.5 m ³	5.8 yd³
Bucket Size — Struck Capacity	3.5 m ³	4.6 yd³
Length — Overall Spade Bucket	10 600 mm	417.3"
— Overall Forks	10 300 mm	405.5"
— Wheelbase	3600 mm	141.7"
Width — Overall with Bucket	2750 mm	108.3"
— Overall without Bucket	2540 mm	100"
— Over Tires	2550 mm	100.4"
Height — Overall Bucket Raised	3300 mm	130"
— Overall to Top of Forks Tine	1900 mm	74.8"
— Body	1650 mm	65"
— Top of Canopy Adjustable High	2182 mm	85.9"
— Top of Canopy Adjustable Mid	2119 mm	83.4"
— Top of Canopy Adjustable Low	2056 mm	80.9"
— Ground Clearance	400 mm	15.7"
Turning Radius — Outer with Bucket	6900 mm	271.6"
— Inner	3300 mm	130"
Angle — Articulation		±43°
— Rear Axle Oscillation		±7.5°
— Maximum Bucket Dump Parallel Lift		45°
Hydraulic Cycle Time:		
Raise		5 Sec.
Dump		9 Sec.
Lower		4 Sec.
Total		18 Sec.
Travel Speeds:	km/h	mph
Forward — 1st	3.1	2
— 2nd	7.4	4.6
— 3rd	13	8.1
— 4th	22.9	14.2
Reverse — 1st	3.1	2
— 2nd	7.4	4.6
— 3rd	13	8.1
— 4th	22.9	14.2
Tilt Breakout Force (SAE)	19 000 kg	41,867 lb
Lift Breakout Force (SAE)	11 000 kg	24,244 lb
Refill Capacity:		
Fuel	300 L	78.3 U.S. gal
Hydraulic	300 L	78.3 U.S. gal
Engine Crankcase with Filter	22 L	5.8 U.S. gal
Transmission	40 L	10.6 U.S. gal
Axles	71 L	18.7 U.S. gal
Drop Box		
Exhaust Conditioner/Water	450 L	118.9 U.S. gal
Cooling System	72 L	19 U.S. gal

*The 3126 meets U.S. EPA Tier 1, EU Stage I equivalent emission standards.

CL210
TRACTIVE EFFORT vs. SPEED
— LOADED

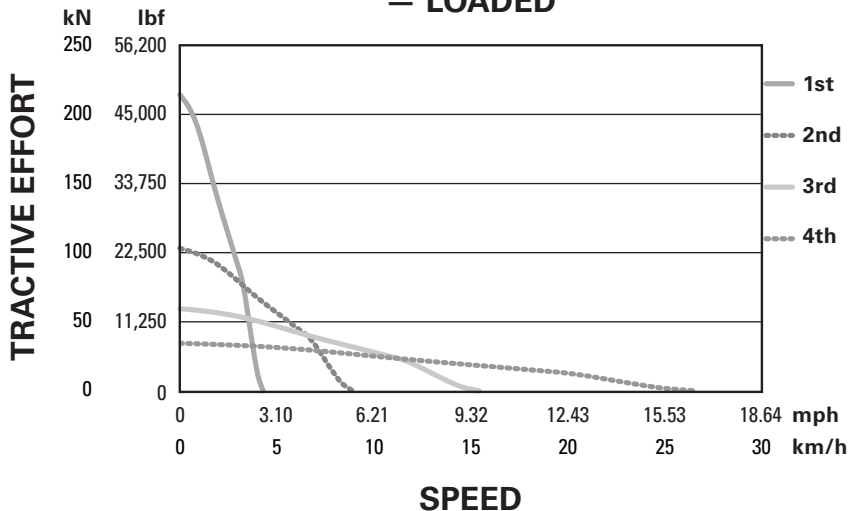

CL210B
TRACTIVE EFFORT vs. SPEED
— LOADED

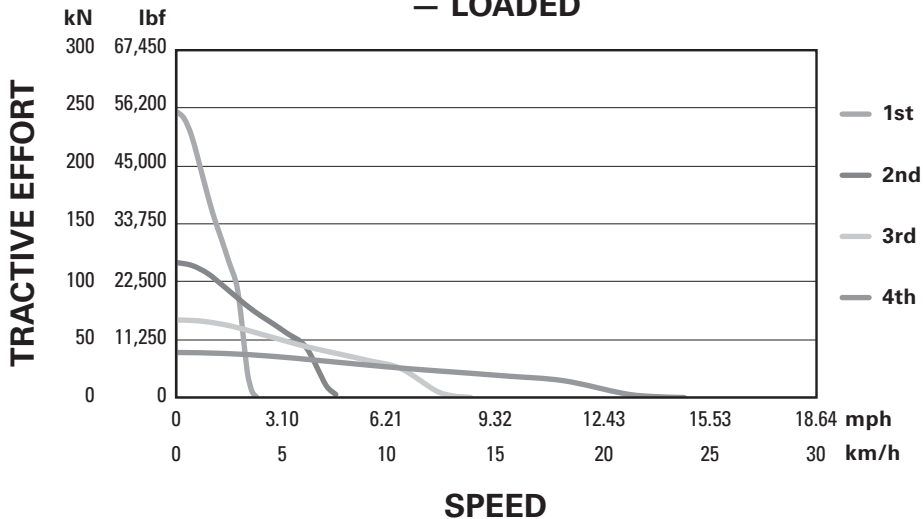

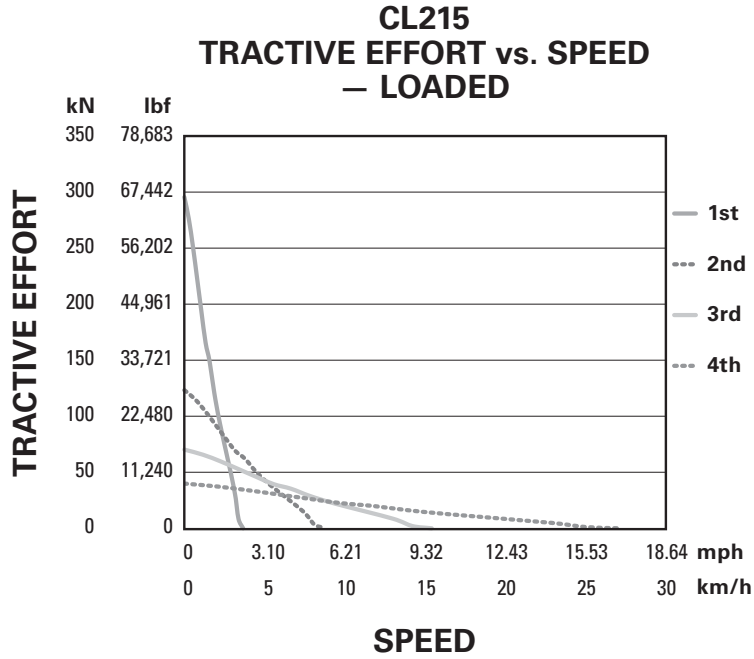

CL210
% GRADE vs. SPEED — LOADED

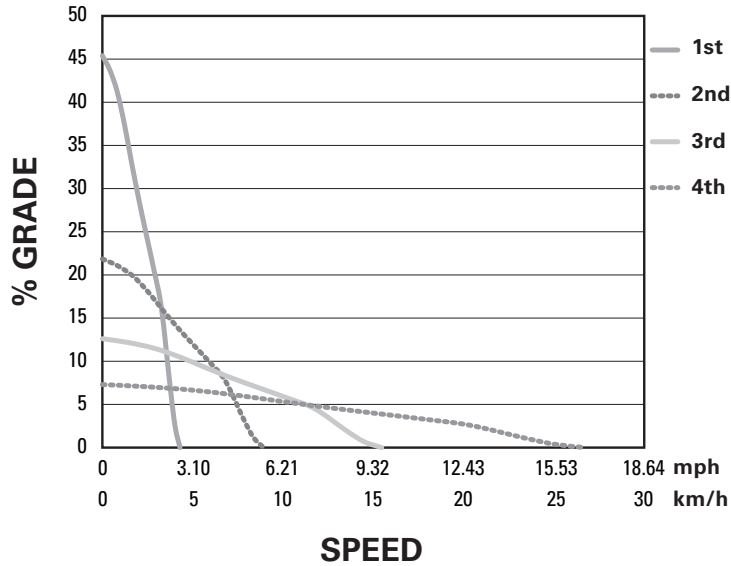

CL210B
% GRADE vs. SPEED — LOADED

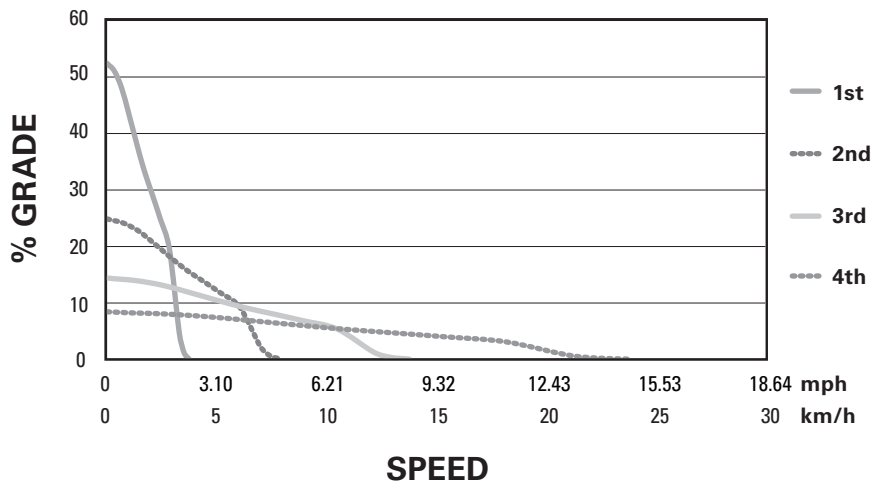

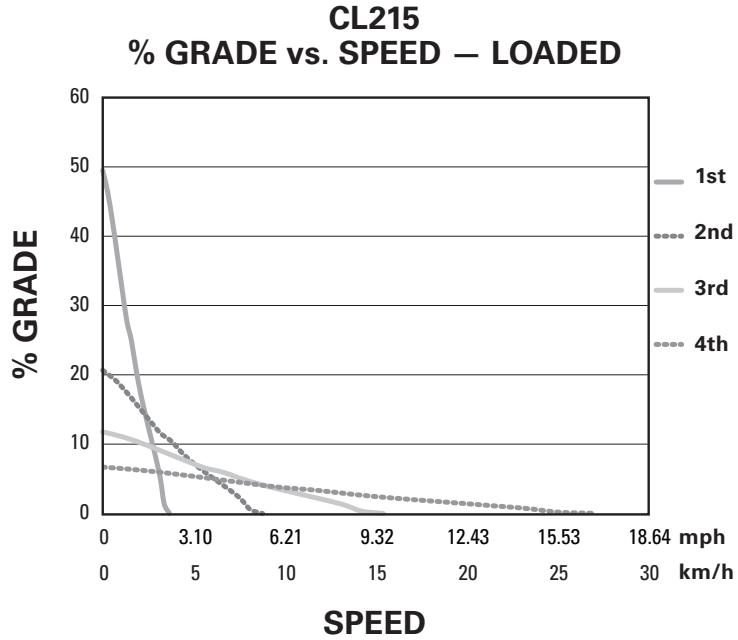

CL210 LIFT CAPABILITY

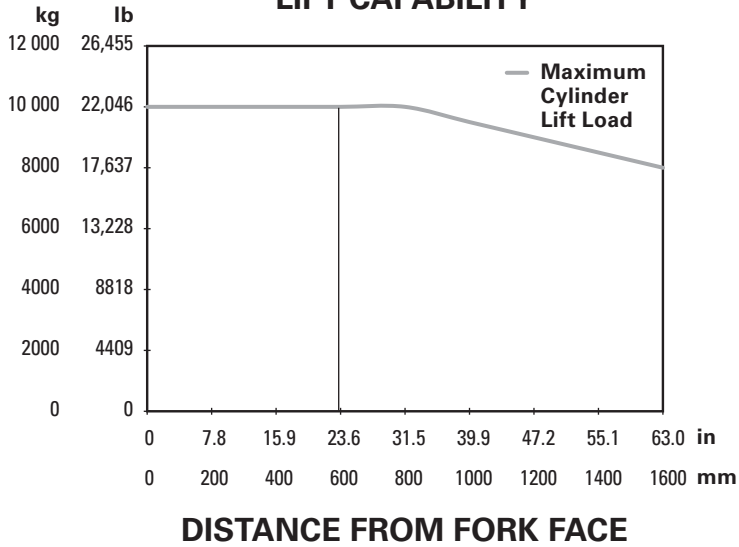

CL210B LIFT CAPABILITY

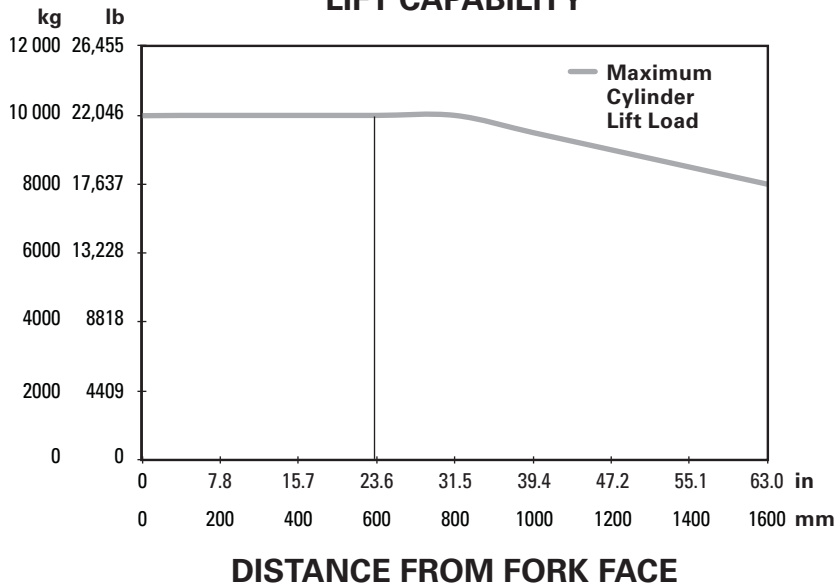

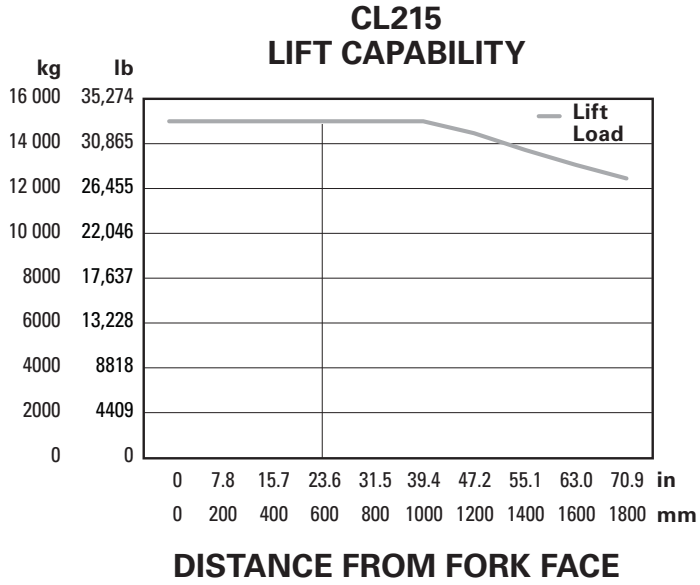

BUCKET LOAD CAPACITIES

MODEL	Bucket Type	SAE Capacity	
CL210	Standard		
	Standard Extra		
	Ejector	3.5 m ³	4.6 yd ³
CL215	Standard		
	Standard Extra		
	Ejector	4.5 m ³	5.8 yd ³

CONTENTS

Introduction	21-2
Safety	21-2
Overview	21-2

MATERIAL RECOVERY FACILITIES, SORTING AND TRANSFER STATIONS

Material Recovery Facilities, Sorting, and Transfer Stations	21-2
Safety	21-2
Technology	21-2
Overview: Changing Attitudes in Waste Applications	21-2
Primary Roles	21-3
MRF's (Material Recovery Facilities), Sorting Stations, Recycling Stations	21-3
MRF's, Sorting and Transfer Stations Applications	21-3
Types of Transfer Stations	21-4
Equipment Selection	21-4
Machine Selection Factors	21-5
Wheel Loaders	21-5
Hydraulic Excavators (Tracked and Wheeled)	21-7
Track-Type Tractors	21-7
Track Loaders	21-7
Landfill Compactors	21-7
Work Tools for Material Recovery Facilities, Sorting and Transfer Stations	21-7

LANDFILLS

Landfills	21-8
Safety	21-8
Technology	21-8
Landfill Overview: Landfilling Now and in the Future	21-8
Equipment Selection	21-9
Track-Type Tractors	21-9
Track Loaders	21-9
Landfill Compactors	21-10
Wheel Loaders	21-10
Hydraulic Excavators (Tracked and Wheeled)	21-10
Wheel Tractor-Scrapers	21-10
Articulated Trucks	21-10
Work Tools for Working in Waste Landfill Applications	21-10
Machine Selection Factors	21-11

Type of Waste and Refuse Densities	21-13
Wet Waste	21-14
Factors Governing Compaction	21-14
Compaction Comparison Estimate	21-15
Landfill Estimating	21-16
Example Problems	21-16

APPLICATIONS

Green Waste/Composting	21-18
Waste Related Energy Production	21-18
Landfills — Renewable Power with Landfill Gas	21-18

TRACK-TYPE TRACTORS

Features	21-19
Specifications	21-20
Blade Specifications	21-25

TRACK LOADERS

Features	21-27
Specifications	21-28
Attachments	21-29

LANDFILL COMPACTORS

Features	21-30
Specifications	21-31
Blade Specifications	21-34

WHEEL LOADERS

Features	21-35
Specifications	21-36

APPLICATIONS

Work Tools	21-44
----------------------	-------

INTRODUCTION

An increasing volume of refuse is generated by every person, household, commercial and industrial, entity day after day ... 365 days a year. Disposal of this waste is a major concern worldwide. Increased governmental regulations designed to protect the environment along with rising transportation and land acquisition costs dictate that customers need to be cost conscience. Waste applications are very demanding and are a significant user of earthmoving and specialty mobile equipment, parts, and service. Caterpillar has Waste Specialists in each of the below categories. If you have questions, please contact your local dealer, Waste representative, or go to *Cat.com*.

SAFETY

Waste industry operators work in some of the world's harshest conditions, so Caterpillar has developed a range of safety resources to help your organization build a culture that delivers everyone SAFELY HOME. EVERYONE. EVERYDAY.™ Caterpillar Safety Services offers training programs, safety checklists, Toolbox Talks, videos, virtual walk arounds and other resources specific to the waste industry at *safety.cat.com*. Click on the Industry Safety tab, and then select Waste.

OVERVIEW

Waste applications are some of the harshest environments that machines and operators will work in. By definition waste is any discarded, rejected, abandoned, unwanted or surplus material.

The Waste Stream — It is important to understand the type of material you are working with when trying to spec a work tool and machine. Through many site assessments and machine productivity/competitive testing, we have found one underlying theme, the type of waste stream and site conditions, will dictate the type of work, tool, and machine. Residential waste (MSW), construction and demolition (C&D), green waste, commercial waste, wet waste*, industrials and sludges, auto fluff/car shred, etc., are just some of the types of waste that are dealt with daily. Each type of waste has different characteristics and properties. Weights of these materials could be as low as 148 kg/m³ (250 lb/yd³) to over 1187 kg/m³ (2000 lb/yd³) (sludges and soils). For example, during a recovering/recycling application, your work tool **Fill Factor** could be as high as **150–200%** when dealing with some MSW and shredded C&D.

MATERIAL RECOVERY FACILITIES, SORTING, AND TRANSFER STATIONS

Safety

MRF's, Sorting and Transfer Stations are not only harsh but busy environments. Inbound loads, mobile equipment, tip floor personnel, and outbound loads, are only a part of the traffic and dynamics dealt with minute by minute in very close settings. Proper PPE (personal protective equipment) for people, guarding for machines, and safety equipment on machines, are essential to keep safe.

Technology

Due to the demanding type of applications within MRF's, Sorting and Transfer Stations, machine technology has to lead the way in offering the ability to: scale loads, manage fuel and machine utilization, keep tire wear to a minimum, and help the operator with visual safety front and rear. Eco Modes on machines allow the ability to switch to a fuel saving mode. Product Link™ helps with tracking fuel burn, machine idle time and utilization. Traction control enables the operator to keep tire wear to a minimum.

Overview: Changing Attitudes in Waste Applications

MRF's (material recovery facilities) sorting, and transfer stations are becoming an important part of the waste industry. Diversion of waste from landfills is a global trend. The European Union, (EU), Canada, Japan, are just a few of the countries who divert 50–75% of their waste stream away from landfills. Cardboard, plastics, paper, food and green wastes are recovered, recycled, or composted. Major changes in the waste stream dictate different methods to gain density. The old mantra of "4–5 passes is enough," now becomes 4–7 passes so that materials can be shredded and bound together for higher densities. The U.S.A. is following this trend as regulations become stricter and the costs of siting/building landfills become higher. Transfer stations become a necessity as disposal sites continue to decline and/or move further away from city centers. MRF's, Sorting/Recycling and Transfer Stations all help reduce primary road and landfill traffic which helps create a safer environment for all.

*Wet Waste — Several country's, regions, and areas globally have concerns with waste that has a high moisture content. If you or your customer are working with a 'higher moisture content' type of waste, please see the *Wet Waste* section under *Landfills — Types of Waste and Refuse Densities*.

Primary Roles

- MRF's (Material Recovery Facilities) Sorting and Recycling Stations are designed to divert recyclable materials from the waste stream. Depending on whether the material is single stream, co-mingled, or pre-sorted, the goal is to divert recyclable material for re-consumption thus lowering the amount of waste placed in a landfill. The natural life of the landfill will be extended by this action. Additional savings of hauling costs can be realized by recovering/recycling materials close to the source (at the MRF or Transfer Station).
- Transfer stations, are designed to consolidate the loads of several residential vehicles in to long-haul vehicles such as rail cars, transfer trailers, barges, and ISO containers. On an average 2–5 inbound loads or more (depending on method of haul) can be consolidated into one outbound load. As a result, transfer stations offer cost savings over direct haul to landfills.

**MRF's (Material Recovery Facilities),
Sorting Stations, Recycling Stations**

A well-coordinated recycling program will reduce volume going to the landfill by 50% or more. Trends are towards sorting and 1 of 2 types of MRF's.

- Dirty MRF — A dirty MRF accepts mixed waste, (normal household waste that has not been separated) that later may be sorted for recycling. Recoverable/recyclable materials are sorted either by hand or automation or a combination of the two. The materials are either baled and/or are hauled to a plant/industry that will utilize the recovered goods.
- Clean MRF — A clean MRF accepts source separated materials from residential or commercial sources. These are normally delivered in separate collection vehicles. As in the 'dirty' MRF, materials are either sorted by hand, automation, or a combination of both, baled and/or are taken to someplace that will recycle or utilize the recovered goods.
- Sorting Stations — Some transfer stations are designed for some waste diversion from mixed streams and are normally described as 'sorting stations.'

MRF's, Sorting and Transfer Stations Applications

There is a wide range of variability in MRF, Sorting and Transfer Station applications and operations. Depending on facility size, amount of material handled, type of station, etc. a wide variety of mobile equipment could be utilized.

In all the facilities mentioned above, materials are tipped by residential or commercial vehicles on to a tip platform or tip floor area. The materials are stockpiled then loaded into hoppers, conveyors, or a haul vehicle. Wheel loaders and excavators (tracked or wheeled) are the primary equipment for stockpiling, loading, sorting, topping off loads, and 'tamping' material into the haul vehicles.

"Volumetric consolidation of material" (normally in Transfer Station applications) is a method of compression and shredding that helps reduce the size of the waste loaded into a haul vehicle. It helps maximize the allowable weight carried by each haul unit. Common machines used for material consolidation are, track-type tractors, track loaders and compactors. These machines are equipped with track shoes or tips/teeth that help in shredding, compression, and reduction of the volume of waste. In most instances, machines performing the material consolidation/reduction are aided by a wheel loader or excavator.

For all applications within MRF's, Sorting, Recycling, and Transfer Stations, there is normally support equipment aiding the primary equipment. Small and compact loaders and excavators, backhoe loaders, skid steer loaders, and fork lifts, are just a few of these machines being utilized.

Types of Transfer Stations

Globally, top loading and compaction transfer stations are the two most popular designs. There are many different types of transfer stations, but, most conform to these two designs.

Top loading systems are the most common and simplest to operate. In top loading designs, there are normally five types of loading arrangements: direct, surge pit, full separation, half separation, and same level or floor loading. Depending on the type of transfer station, wheel loaders, excavators (tracked or wheeled), dozers, track loaders, and compactors can be utilized alone or in systems providing quick efficient waste handling.

Compaction transfer stations utilize hydraulic compaction equipment prior to or during the loading of the haul vehicle to compress the material into bales/logs or into the haul vehicle itself. The hydraulic compactor can be top loaded or side loaded by wheel loaders or excavators, depending on the type of design.

EQUIPMENT SELECTION

In waste applications, the largest single cost in daily operations is purchasing, operating, and maintaining the equipment that will handle the waste. Undersized, inadequate, or unreliable equipment results in inefficient operation and higher maintenance and fuel costs. As in many Cat® applications/industries, right sizing equipment should follow the familiar path of; Task, Tool, Machine. **TASK:** Understand the task or application the machine will work in. **TOOL:** What tool or tools will aid the machine in performing the task most efficiently? **MACHINE:** After finding the 'right tool(s)' to perform the job, then match it to the right sized machine.

Equipment in MRF, Sorting and Transfer Station applications perform the below operations.

1. **Stockpiling the Waste.** Once it is dumped onto the tip floor, wheel loaders, wheeled or tracked excavators, track-type tractors, track loaders, or compactors will push the material up into a stockpile. Stockpiling helps: recover storage and working space within the building, get the waste slightly denser, store the waste till it can be processed or loaded.

Factors for a machine in stockpiling are: type of tool, reach, lift, ceiling height, storage space, and maneuverability.

2. **Recovering and Sorting.** Waste streams are rich in recoverable/recyclable materials. Waste diversion or recovery not only helps reduce the amount of waste going to landfills, but adds to profitability when sold to commodity markets. Sorting and recovery prior to stockpiling or loading can be accomplished with specialized machines equipped with sorting grabs, grapple buckets, or grapples. Stockpiled materials are sorted prior to loading or when loaded with grapples or grapple buckets. All sizes of equipment could be used depending on type of material and material flow. Compact wheel loaders/excavators, skid steer loaders, backhoe loaders, medium wheel loaders and excavators, and telehandlers should be sized according to amount of waste and type of application and type of tool(s) needed. It should be noted that in this type of application couplers on primary and support equipment could be a necessity.
3. **Loading the Waste.** No matter what type of haul/load out, vehicle/conveyor or hopper, materials are either pushed, load and carried, grappled or bucket loaded into transport vehicles or containers. Wheel loaders, tracked or wheeled excavators, track-type tractors, track loaders, compactors or any combination of these (systems) can be utilized. Note that the type of loading application will dictate the type of tool and machine necessary for optimum efficiency in the loading process.
4. **Reducing Volume of Material.** Haul vehicles/transport vehicles need to leave with the maximum allowable weight for the type of transportation mode being used. Wheel loaders and tracked or wheeled excavators can keep stockpiling or turning the waste to get the waste more dense. However, best compression, shredding and volume reduction of the waste is seen by layering waste in thin layers, continuous running over (passes) the waste, turning the waste, and "working" the waste. Track-type tractors, track loaders, and compactors normally see an average of about 60–120 kg/m³ (100–200 lb/yd³) higher density than wheel loaders or excavators in this type of application. Type of track or wheel/tip design is very important for shredding and compression in this type of application.

5. **Support Equipment.** Primary equipment often are supported by machines performing; clean up and sorting with specialized work tools, sweeping with brooms, stacking and loading with pallet forks or bale clamps, etc. Compact wheel loaders and excavators, backhoe loaders, skid steer loaders, and telehandlers equipped specifically for the tasks they need to perform can increase production and efficiency in all areas. Most of the time one or two machines are equipped with couplers to increase their versatility and efficiency helping lower costs.

Machine Selection Factors

Parameters that could influence tool and machine size, quantity, and possible combinations of machines in MRF's, Sorting and Transfer Stations could include:

1. Amount and type of daily waste to be handled (daily tonnage). During daily inbound tonnage, some peak delivery times occur. It has been found that approximately 50%–60% of inbound tonnages occur on 2–3 “Peak” hours/times of the day. Depending on the inbound tonnage during these times, machines could be spec'd towards these peak times (type and size of facility). What loading platform (top loading/compaction facilities) are they using and how much overall space to work in.
2. Facility load out dynamics.
 - a. Maneuverability
 - b. Ceiling height
 - c. Floor size/storage space
 - d. Floor arrangements
 - e. Type of load out (below grade, ½ separation, same level, surge pit — loading)
 - f. Haul unit specifications
 - g. Inbound/outbound traffic patterns
3. Requirements for volume reduction for higher tonnages in load out.
4. Supplemental tasks performed in daily operations.
5. Budget.
6. Future growth.

NOTE: Waste applications place high demands on machinery requiring protection of the machine and its components. Special guarding is needed on all moving parts like axles and drive shafts. Windshields, fuel and hydraulic tanks, radiators, hoses, engine enclosures, are all vulnerable to debris and damage and require guarding. Specially designed debris screens and radiators will ensure clean out and better heat transfer for more efficiency.

Wheel Loaders

Wheel loaders are normally the primary machine used in MRF's, Sorting and Transfer Stations. Wheel loaders are designed, guarded and built in factory to withstand these harsh environments. Primary operations include: sorting and recovery of materials, push and stockpiling of waste, cleaning floors, support work, and loading conveyors/hoppers/and outbound haul vehicles. Depending on type of material, reach needed, amount of sorting required, ceiling height, floor wear, and type of load out, the machines can be equipped with a wide variety of buckets, attachments and tires. Keeping the thought process of Task, Tool, Machine in mind, a good knowledge of the facility, its waste stream, and type of support work, is needed to ‘right size’ the wheel loader(s) for these applications.

- Compact Wheel Loaders (906–908) — Normally used in small tonnage MRF's/Sorting Stations or as support in larger stations, maneuverability and versatility (coupler equipped) are its main strengths.
- Small Wheel Loaders (924–938) — Used in small–medium MRF's, Sorting and Transfer Stations and as support in larger stations, the small wheel loader brings maneuverability and versatility (coupler equipped) to these types of applications.
- Medium Wheel Loaders (950, 962, 966, 972, 980) — When larger tasks, better reach, higher stockpiling, larger tonnages, etc. are needed, a medium sized wheel loader is normally utilized. These machines have excellent weight to horsepower ratio for better traction and moving larger loads.

The following Wheel Loader Operating Recommendations Chart is an estimate of possible machine(s) for tonnages and type of facility. (Note: Keep in mind the task/application the machine will work in, what tool(s) might accomplish the tasks and then size the machine.)

Wheel Loader Operating Recommendations

Tons per Day Volume	Clean MRF Recovery/Recycling	Dirty MRF/Sorting Station	Waste Transfer Station	C&D MRF	C&D Transfer Station
0-100	906-930	924-930	924-930	930-950	930-950 ^b
100-350	908-930 ^a	924-930 ^a	924-938 ^a	950-966 ^{d*}	950-966 ^{d*}
350-500	930-950	930-950 [*]	938-966 [*]	966-980 ^{a*}	950-966 ^{d*}
500-1000	930-950 ^{e*}	938-950 ^{e*}	950-966 ^{e*}	966-980 [*]	950-980 ^{d*}
1000-1500	938-950 ^{e*}	938-966 ^{e*}	966-980 ^{d*}	950-980 ^{d,e*}	966-980 ^{d,e*}
1500-2000	950-966 ^{e*}	966-980 ^{e*}	966-980 ^{d,e*}	950-980 ^{e*}	966-980 ^{d,e*}
2000-2500	950-966 ^{e*}	966-980 ^{d,e*}	966-980 ^{d,e*}	950-980 ^{e*}	966-980 ^{d,e*}
2500-3000	950-966 ^{e*}	966-980 ^{e*}	966-980 ^{e*}	950-980 ^{e*}	966-980 ^{d*}
3000 Plus	966-980 ^{e*}	980 ^e	980 ^e	980 ^e	980 ^{d,e}

C&D = Construction and Demolition

*Depending on inbound/outbound tonnage, reach, production required, this machine could step up to either a 962 or 972.

- a = Multiple machines recommended (contact your local Cat dealership for recommendations)
- b = Depends on type and density of C&D material
- c = Waste stream mixture may require multiple machines
- d = Operating hours may require additional machines
- e = Multiple machines required

The above are rule of thumb estimates. Your application might vary enough to change the machine for the above recommendations. Other questions that might need answered are:

- What are you loading? Conveyors, haul vehicles, hoppers, etc.?
- If loading conveyors or drums — what are the feed capacities, FPS rate?
- How much storage capability in your building?
- What type of loading are you performing?
- How much reach is required for stockpiling and loading?
- "Other" required operations that the machine might perform?

Additional Considerations

All facilities are different and require special considerations when ordering and specifying tools and equipment. If tonnage and operating hours change, then tool and machine might change. Machine weight has to balance power to ground for best traction on slick floors. Keep in mind Task, Tool, Machine. (What type of work will the machine be asked to perform during the shift? What tool(s) will apply to that type of work cycle? What machine fits to that type of tool?)

It should be noted that most of the wheel loaders being sold into MRF, Sorting and Transfer Stations are high lift. This arrangement offers increased reach and lift height not only for loading and stockpiling, but in case the haul vehicle has to be brought to the same level as the machine to be loaded.



Hydraulic Excavators (Tracked and Wheeled)

Hydraulic excavators (tracked and wheeled) are often found in MRF, Sorting and Transfer stations either as a primary or secondary tool for loading haul vehicles/conveyors/hoppers, tamping and finishing off loads, and sorting materials. Fast cycle times are the primary advantage of an Excavator over a Wheel Loader. Wheeled excavators come with a maneuverability advantage especially in tight loading and stockpiling areas. Depending on the type of application, tracked and wheeled excavators would be equipped either for high production loading/compaction, or with sorting/separating tools for recovery of recyclable materials.

Again, keeping the Task, Tool, Machine concept in mind, you should take into account the following when sizing a tracked or wheeled excavator. Type of material and density, tonnage, work load for the machine, ceiling height, work area/swing area, floor size, along with maneuverability needed, ability to 'see' into haul vehicles or down into the floor load out area (cab risers), and reach. Special guarding packages, radiators, and reversing fans are options that may be needed to meet the most demanding needs.

Track-Type Tractors

Waste Handling Track-Type Tractors are designed, guarded, and built in factory so that they can accommodate all waste applications. Although its primary use is for pushing and layering the waste and cover materials in landfills they offer alternative waste movement and volume reduction in large transfer stations and C&D transfer stations. Ex: In surge pit operations where waste is tipped into a level below the tipping floor. Track-type tractors will push, layer, and compress/shred the material during operations and push into a haul vehicle. This method is used when maximum volume reduction is required or peak rate of waste exceeds available floor space.

Track Loaders

Waste Handling Track Loaders are designed, guarded, and built in factory so that they can accommodate all waste applications. Transfer stations are a strength for this machine due to its versatility in this application. Sorting, pushing, layering, and compaction are all part of typical operations within the transfer station application. Just like the track-type tractor, the track loader is used in higher tonnage transfer stations, C&D transfer stations, and when waste needs volume reduction. Equipped with a multi-purpose bucket, the track loader can sort, push, layer, compress and shred, and load material into outbound haul vehicles.

Landfill Compactors

Although landfill compactors are designed for spreading and compacting large volumes of material in a landfill environment, in some instances, transfer stations might have a large enough working area to allow the compactor to be utilized to reduce waste volume prior to loading into haul vehicles. They offer two advantages in this type of application.

1. They are configured and guarded to work in this type of environment.
2. They achieve higher compression, shredding, and compaction levels compared to other machines.

CAUTION! Operating a landfill compactor, track-type tractor, or track loader on a concrete floor could be counterproductive due to floor wear and maintenance costs. Always keep a layer of waste between the floor and machine until final movement of the day. Wheel loaders and/or excavators (wheeled/tracked) should be used to support these machines. (Please see #4 under previous Equipment Selection.) (It is not recommended to use a landfill compactor larger than the 826.)

Work Tools for Material Recovery Facilities, Sorting and Transfer Stations

As described in the opening statements of this section, the waste stream can consist of many different types of materials sometimes all blended together. For that reason, work tools become a very important part of moving, sorting, and dozing in waste applications.

At the end of this section, there will be a Work Tool section and chart discussing possible tools to use. Please contact your dealer/regional waste representative for more information.

LANDFILLS

Safety

Landfills are harsh and busy environments. A variety of vehicle traffic on haul roads, busy tipping areas, people on the tip floor, a large variety of different types of waste, mobile heavy equipment operations, special waste haulers, etc. are all part of the dynamics of a landfill working face. Proper PPE (personal protective equipment) for people, guarding for machines, proper training, and safety equipment on machines, are essential for a safe work environment.

Technology

Due to the demanding environment and its possible applications, machine technology has to lead the way in offering the ability to: manage fuel and machine utilization, keep undercarriage cost to a minimum, and help the operator with visual safety front and rear. Eco Modes on machines allow the ability to switch to a fuel saving mode. Product Link helps with tracking fuel burn, machine idle time and utilization. Computers, VIMS™ (Vital Information Management Systems,) and Traction Control (in some track-type tractors) helps operators control spin and keep track of mileage to help decrease undercarriage wear.

Landfill Overview: Landfilling Now and in the Future

Although recovering and recycling materials is becoming more prevalent, landfilling still provides a place to deposit waste materials or refuse not able to be recovered/recycled. A landfill protects the environment by disposing of the waste in an engineered cell. Siting, designing, building, and operating a landfill is costly. Depending on country, state, region, etc., landfills have to design and operate to very strict regulations. Proper equipment selection and daily operating techniques can maximize and extend the operational life of the landfill along with lowering costs.

Primary types of landfills are MSW (municipal solid waste/residential), C&D (construction and demolition), and Hazardous (hazardous industrial sludges, asbestos, etc.) with the majority of landfills being MSW or residential waste. Landfills can take in many different types of materials and will range from less than 90 metric tons/day (100 tons/day) to over 13 610 metric tons/day (15,000 tons/day). Depending on the country you live in and its regulations on recycling, the waste stream going to the landfill could be a mix of food wastes, packaging, plastics, cardboard/paper, metals, C&D, etc. In some highly regulated countries, food wastes, plastics, cardboard/paper, metals, and C&D, are diverted to C&D landfills, composting sites, and/or facilities that will recycle the recovered product.

In keeping with environmental concerns, most landfills have a highly engineered method of dealing with leachate, gas, and inbound waste. (See the *Caterpillar Equipment and Application Guide — Waste Landfills* or your countries Environmental Landfill sites.) Once cell, leachate, and gas methane extraction development are in place, the basics are to: push, layer, compact the waste in thin layers, adding daily cover or ADC (alternative daily cover) sparingly. The idea is to fill the landfill with as much waste as possible without robbing airspace by using too much cover soil.

Future. Diversion rates of recoverable materials within the EU Canada, some Asia Pacific countries, and starting in the U.S. will eventually reach 60%–80% diversion or more. This will all depend upon commodity markets and the demand for the recycled materials. It also drastically changes the waste stream going to the landfill. The type of waste going to a landfill from a good diversion plan is normally light plastics, packaging, hard to handle materials, metals and materials that can't be recycled. This waste stream might require different handling, processing, amount of passes, and compaction techniques to shred and compress it as much as possible and possibly different wheel tips and tip patterns. (See text in *Factors Governing Compaction —Developing a Pattern and Running Proper Passes.*)

EQUIPMENT SELECTION

A landfill's largest single cost for daily operations is purchasing, operating, and maintaining its mobile equipment fleet. Undersized, inadequate or unreliable equipment results in low machine utilization, higher fuel and maintenance costs and eventually improper landfill operations.

Landfill equipment performs three major distinct functions:

1. Waste disposal: Which includes, pushing, spreading, and compaction. Track-type tractors, track loaders, and landfill compactors are primary machines in this application.
2. Cover material mining and application: Machines will provide daily cover requirements whether cover soil or ADC (alternative daily cover). If supplying cover material is a machine's sole function, then it can be selected on the same criteria as normal earthmoving. Distance to borrow pit, material characteristics, volume to transport, production needs, underfoot conditions, etc. are all important in right sizing the equipment. Lowest cost is determined by best efficiency and lowest cost/m³ (yd³).
3. Support activities: What 'other' roles might the equipment be asked to accomplish or what support is needed for the primary equipment? Water trucks to keep dust down, motor graders to maintain haul roads, wheel loaders/excavators/backhoes/skid steer loaders, telehandlers, etc., with couplers that can utilize all types of work tools, generators, service vehicles, air compressors, etc. are all necessary equipment to keep the landfill running efficiently.
4. Peak periods: Most landfills have to deal with 2–4 periods during the day where more volume of waste is delivered by more inbound vehicles than normal. These are called peak periods. Depending on the size of the landfill and amount of peak waste coming in, it should be noted that some landfill equipment can or should be specified in order to handle these peak times of waste and vehicles.

There are many variables when choosing the "right" sized equipment for landfill use. Again, we point to the direction of thinking: Task, Tool, and Machine. What are the application, production, compaction, support requirements? What tool or tools can accomplish this task? And finally, what machine(s) will handle the tool(s) most efficiently? (To help with 'right sizing' a compactor and/or track-type tractor together, Waste Fleet Analysis/WFA (downloaded at *Dealer.Cat.com*) can be utilized as a rule of thumb to determine possible compactors/track-type tractors and combinations of the two.)

Track-Type Tractors

Waste Handling Track-Type Tractors are designed, guarded, and built in factory so that they can accommodate all waste applications. The track-type tractor is the most popular machine on the landfill. They prepare the site, build haul roads, push/spread/and sometimes compact the refuse, spread cover material, and perform a variety of support functions. Quantity of material to be moved/hr., type of inbound delivery vehicles, distance of push, support work needed, etc., all should be taken into consideration when sizing a track-type tractor for its application. Economic distances for dozing waste or cover soil efficiently is no more than 90 m (300 ft) or less. The track-type tractor, when used to compact, can achieve densities of approximately 475–590 kg/m³ (800–1000 lb/yd³) (MSW, 3:1 or less slope, multiple passes).

Track Loaders

Waste Handling Track Loaders are designed, guarded, and built in factory so that they can accommodate all waste applications. These machines are highly versatile and perform many primary and support activities. They can be used in any size landfill and are ideal for landfills under 135 metric tons (150 tons) since they can work solo to perform waste handling and cover material functions. Equipping the machine with a coupler or a multi-purpose bucket increases its versatility. The multi-purpose bucket can be used for pushing waste, sorting materials, and dozing cover soils. The machine can be equipped with different track options from double to single grouser allowing it to work in normal operations or be utilized to more aggressively shred materials (Heavy MSW or C&D). Utilizing correct methods of compaction, (spread thin and load the bucket with soils to increase weight) will achieve higher densities during compaction. Compaction densities can range from 475–590 kg/m³ (800–1000 lb/yd³).

Landfill Compactors

Landfill Compactors are specifically designed, built, and guarded in the factory to effectively shred and compress large volumes of waste. Depending on landfill size and amount of tons inbound daily, the compactor will work solo (pushing, spreading, compacting) handling all the inbound waste, or work in tandem with a track-type tractor (track-type tractor — push/spread, compactor — shred/compact). When working the track-type tractor and landfill compactor together as a “system,” productivity and compaction densities will increase. Depending on the type of waste stream to be compacted, initial waste density, depth of the layer spread, and size/weight of the landfill compactor, compaction densities can be 593–1100 kg/m³ (1000–1854 lb/yd³). Although the compactor can work on steeper slopes, best slopes for highest density for landfill compactors are 4:1 or less.

Wheel Loaders

Wheel loaders are designed, guarded and built in factory to withstand these harsh environments. Not recommended as a compaction machine, wheel loaders are mobile and versatile and sometimes are used by communities sharing a single machine which can travel and support community/landfill projects. Wheel loaders are normally equipped with a coupler and many different tools to make it more versatile. Loading cover soils, sorting, clean up, spreading road material, and handling leachate/gas pipes are just a few of the activities wheel loaders perform in landfill applications.

Hydraulic Excavators (Tracked/Wheeled)

Every landfill has a tracked or wheeled excavator supporting its operations. Whether equipped with a coupler, which accommodates multiple tools, or a pinned attachment, wheeled and tracked excavators offer superior versatility in: cell development, cover soil mining, ditch/pond clean out, and leachate and gas extraction support. Wheeled excavators give you mobility and maneuverability along with the ability to be able to respond quickly to support needs. When loading cover materials is the primary application, it is critical to know the size of the haul vehicle, type of material, and production required, so as to define the proper size bucket, stick, and finally machine to meet production needs.

Wheel Tractor-Scrapers

Wheel tractor-scrappers mainly perform cover soil operations. Wheel tractor-scrappers work in site preparation, cell construction and hauling/placing cover material. When underfoot conditions are good and the haul over 185 m (600 ft) the wheel tractor-scraper will be economical. The machine should be selected as if performing a typical earthmoving application. Average sized landfills prefer the work alone capability of either an elevating or twin engine scraper since they are self-loading machines. Larger landfills sometimes utilize larger push-pull scraper units to meet their daily cover soil production needs. Preferably, the scraper unloads the cover material close to the working face where track-type tractors or track loaders can push and spread the material in the required layer depth. This will reduce tire damage and extra maintenance costs to the machine.

Articulated Trucks

Articulated trucks are versatile, highly maneuverable, all weather haulers that can negotiate poor underfoot conditions. Like wheel tractor-scrappers, articulated trucks work in site preparation, cell construction, and hauling/placing cover material. Articulated trucks are normally loaded by a variety of loading tools and economically effective with hauls from 0.2 km–5 km (600 ft–3 miles). In dump configuration, cover material is dumped close to the work face and spread by a supporting track-type tractor or track loader. Ejector configured trucks are preferred and provide safer on-the-go dumping in normal to softer more sloped ground conditions where a “dump configuration” machine would not be suitable. Cat articulated trucks offer optional container handling and refuse body configurations for specialized landfill applications.

**Work Tools for Working in
Waste Landfill Applications**

As described in the opening statements of this section, the waste stream can consist of many different types of materials sometimes all blended together. For that reason, work tools become a very important part of moving, sorting, and dozing in waste applications.

At the end of this section, there will be a Work Tool section and chart discussing possible tools to use. Please contact your dealer/regional waste representative for more information.

Machine Selection Factors

Selecting the type, size, quantity, and combination of machines required to spread, compact, and cover varying daily refuse volumes is determined by the following parameters:

1. Amount and type of waste to be handled (daily tonnage) (peak periods should be charted and reviewed and taken into considerations)
 2. Amount and type of cover material to be handled
 3. Distance cover material to be transported
 4. Compaction/density requirements
 5. Weather conditions
 6. Supplemental tasks
 7. Budget
 8. Growth
- A. Daily tonnage and peak periods — Amount of waste produced by a community is the major variable in selecting the appropriate sized machine. The following chart serves as a “guideline” in sizing a landfill machine. For example, if a community generates approximately 180 metric tons (200 tons) of refuse per day, a D6, 953, and/or an 816F2 landfill compactor could be considered. Depending on the tonnage, type of waste, and peak periods, multiple machines or a ‘system’ of machines (ex: 836K and D8T) could be considered. As discussed earlier, peak periods during the day, (periods of time where a higher than normal average amount of waste comes in) could dictate what size machine is needed to keep up with the inbound waste. During these times, another machine could be added to the mix until the waste is layered and compacted correctly.
- B. Amount and type of cover material to be handled — Landfill, size, type, and methods of operation vary dramatically from site to site. The type and amount of cover material utilized is important. The use of Alternative Daily Cover (ADC) is highly recommended to reduce loss of valuable airspace. Landfill managers track cover material use as close as they track their airspace and maintenance. The use of cover material is broken down into three segments: daily, intermediate, and final. Landfill operators agree that daily cover should be no more than 10% or less of the entire lift. No matter how much daily or intermediate cover is used, the growing trend is to remove or ‘mine’ cover material prior to beginning the daily operation in that area. The total combination of daily and intermediate cover if not removed, could end up being more than 25%–35% of total landfill airspace loss. Removal of cover material increases airspace and helps facilitate leachate and gas migration.

Blade/bucket design is paramount if a machine is used specifically for working with cover soil. Straight blades, Semi U blades, and multi-purpose buckets are primarily used by track-type tractors and track loaders. With the need to carry and layer cover material to an exacting maximum, blades/buckets that can shed material easily are recommended. If the machine will be used in waste and cover soil operations, then a Semi Universal blade (for load and carry) and the multi-purpose bucket are good recommendations.

- C. Distance cover material is to be transported — Whether working with daily, intermediate, or final cover, the following guidelines are recommended for cover material movement. Quantity of material to be moved, required production, and maintenance results, must also be considered when using these guidelines.

Track-type tractor	0-61 m (0-200 ft)
Track loader	
Push/spread	0-61 m (0-200 ft)
Load & Carry/spread	0-150 m (0-500 ft)
	(Type of material/application needs to be considered for possible excessive track wear)
Wheel loader	0-185 m (0-600 ft)
Wheel tractor-scraper	over 185 m (over 600 ft)
Articulated truck	over 185 m (over 600 ft)
	(Haul distance, road and borrow pit conditions, weather, tip area dynamics — all need to be taken into consideration when making a decision to use a scraper or articulated truck)

- D. Compaction requirements — Best utilization of airspace is critical to extending landfill life. Quantity and type of material, work face variables, operator skill, operating hours, size and type of equipment, etc., all play a part in achieving high densities. Highest density is gained by utilizing a ‘system’ approach of machines (track-type tractor pushing and spreading — compactor leveling and compacting) or to a lesser extent, just using a compactor.

The following product segments of this section will contain features, specifications, and work tools for primary Cat Waste Handling machines. Additional drawbar/rim-pull vs. groundspeed charts, ground pressures, controls, production estimating tools, information, can be found in respective product sections within this *Performance Handbook*.

The below *Machine Tonnage and Usage Selection Factor Guide* should be considered a ‘rule of thumb.’

To use; find the amount of tonnage/day that the landfill takes in (left column) — to the right of that column find the possible machines that could be used for that amount of tonnage (marked by an ×). Please note that depending on the type of waste, amount of waste/day, and even amount of waste/hr., a single machine could be utilized or multiple machines might be necessary.

For example: Follow the left column down to 45.3 to 136 Metric Tons/day (50 to 150 tons per day) — For MSW Landfills — All the machines marked by ×’s could be utilized. Smaller machines for smaller tonnages, larger machines for larger tonnages. Depending on budget and required density, and required support activity, a single machine might be used or a combination of machines could be needed.

Machine Tonnage and Usage Selection Guide	D6N	D6T	D7E	D8T	D9T	953	963	973	816F2	826K	836K
0 to 45.3 Metric Tons per Day (0 to 50 Tons per Day)											
MSW Landfills	×	×				×	×				
Construction and Demolition Landfills/Other		×	×				×	×			
45.3 to 136 Metric Tons per Day (50 to 150 Tons per Day)											
MSW Landfills	×	×				×	×		×		
Construction and Demolition Landfills/Other		×	×				×	×	×	×	
136 to 227 Metric Tons per Day (150 to 250 Tons per Day)											
MSW Landfills	×	×				×	×	×	×	×	
Construction and Demolition Landfills/Other		×	×	×			×	×	×	×	
227 to 317.5 Metric Tons per Day (250 to 350 Tons per Day)											
MSW Landfills		×	×	×			×	×	×	×	
Construction and Demolition Landfills/Other			×	×				×		×	
317.5 to 453.6 Metric Tons per Day (350 to 500 Tons per Day)											
MSW Landfills		×	×	×			×	×		×	×
Construction and Demolition Landfills			×	×	×			×		×	×
453.6 to 680.4 Metric Tons per Day (500 to 750 Tons per Day)											
MSW Landfills			×	×			×	×		×	×
Construction and Demolition Landfills/Other			×	×	×			×		×	×
680.4 to 907.2 Metric Tons per Day (750 to 1000 Tons per Day)											
MSW Landfills			×	×	×			×			×
Construction and Demolition Landfills/Other			×	×	×			×			×
907.2 to 2721 Metric Tons per Day (1000 to 3000 Tons per Day)*											
MSW Landfills			×	×	×			×			×
Construction and Demolition Landfills/Other			×	×	×			×			×
2721 PLUS Metric Tons per Day (3000 PLUS Tons per Day)*											
MSW Landfills			×	×	×			×			×
Construction and Demolition Landfills/Other				×	×			×			×

*Might require multiple machines or ‘systems.’ Systems = dozer/compactor combination (S).

TYPE OF WASTE AND REFUSE DENSITIES

The type and density of the waste stream inbound to MRF’s, Sorting/Transfer Stations, and Landfills determine how it is handled, the type of work tool, and ultimately the type of machine to handle it. Type of waste to be handled will strongly influence machine selection. The major waste components for the community and landfill should be identified and machine selection based on the type of waste and compaction density required. For example, if the site receives a high proportion of material that is hard to compact like medium to heavy C&D waste, (rocks, bricks, concrete, tree stumps, telephone poles, etc.) a landfill compactor might have a hard time achieving normal densities without the help of a track-type tractor or track loader. Tracked machines have more difficulty pushing and compacting bulk waste such as trees, road materials, iron, etc. A combination or “system” of both tracked machine and landfill compactor might work best. Depending on the type of waste, different tip/cleat designs will help with shredding, traction, and density.

On average, Americans generate approximately 2 kg (4.4 lb) waste/day while the European Union (EU) generates about 1.4 kg (3.0 lb) waste/day. (Before recovery/recycling) Waste composition varies from location to location, the following charts are representative of the waste stream in the U.S. and EU. (Please note that the growing trend within the EU and to a lesser extent the U.S. is to use waste as a resource. Subsequently the numbers represented in these charts will have annual changes.) The EU-27 are avoiding waste to landfills through recovery, recycling, composting, and incineration, and are trying to use waste as a resource. For the EU-27, approximately 38% of waste is landfilled. The U.S. is currently approximately 33% recovered/recycled with a slow trend towards composting.

2011 EU-27 Total MSW Generation (by material)

Paper/Cardboard	40.0%
Food Scraps	25.0%
Plastics	19.0%
Metals	6.0%
Wood	15.0%
Glass	20.0%
Shares of packaging waste	<i>Courtesy of EEA</i>

Generally, loose residential and commercial refuse weighs 150–267 kg/m³ (250–450 lb/yd³). A refuse truck will increase this density to 237–593 kg/m³ (400–1000 lb/yd³). Once ejected from the refuse truck, some waste has a ‘rebound’ tendency and it will lose some density. Typically, loose on the landfill, we see loose refuse weights with an average of 207–475 kg/m³ (350–800 lb/yd³). This waste needs to be compacted and in-place densities can vary from between 356–889 kg/m³ (600–1500 lb/yd³) depending on the shredding and compression applied by the compacting machine. C&D landfill sites, depending on type of inbound material, sometimes see a wide range of densities from 593–1187 kg/m³ (1000–2000 lb/yd³) (depending on compacting machine). Cover material will raise fill densities 119–296 kg/m³ (200–500 lb/yd³) from the numbers above. When asked about the density of their landfill, most managers will give you the ‘in-place with cover’ estimates of density — Please see weights of refuse below:

Weight of Refuse

	kg/m ³	lb/yd ³
Loose Refuse:	148-237	250-400
Packer Truck:	237-474	400-800
Fill Density:	355-949	600-1600
Refuse and Cover:	474-1186	800-2000

**2011 U.S. Total MSW Generation (by material)
250 million tons (before recycling)**

Paper/Cardboard	28.1%
Food Scraps	14.5%
Yard Trimmings	13.5%
Plastics	12.7%
Metals	8.8%
Rubber, Leather and Textiles	8.2%
Wood	6.4%
Glass	4.6%
Other	3.3%
Before Recycling	<i>Courtesy U.S. EPA</i>

Wet Waste

There are a number of global landfills that deal with a heavier than normal amount of ‘wet waste,’ or waste with higher than normal moisture content. In previous discussions, ‘type of waste’ will determine how the waste is handled or worked. With higher than normal moisture contents, the idea of ‘multiple’ passes (3–5) will be changed. For example, the waste will already be heavier/denser than normal (ex: 1186 kg/m³ or 2000 lb/yd³) this type of waste might only require a track-type tractor or track loader to spread it. During the spread cycle, the shredding/tearing action of the track cleats provides an additional density. Or, the compactor could be equipped with a ‘wider’ flotation wheel (optional wheel from Caterpillar) that provides better flotation along with shredding and compression that will add to the density of the waste. Whichever system is used, less passes on the waste are needed to reduce the waste and add to density. (Too many passes could lead to the waste breaking down and causing traction/flotation problems on the landfill.)

FACTORS GOVERNING COMPACTION

There are four factors that will determine best compaction density (layer thickness, patterns/passes, slope, and moisture content). The three areas that can be affected most by proper machine applications are:

1. Refuse Layer Thickness — The single most important factor in gaining maximum density is the depth of the layer being spread to compact. Depending on the amount of tips/wheel, type of tips, type of waste, and weight of the machine, optimum layer depth will vary. Through field testing and computer analysis, optimum layer depths for highest density have been analyzed. Below are guidelines of optimum layer depth for each compactor.
 - a. 816 — 0.3–0.4 m (12–15 in)
 - b. 826 — 0.45–0.5 m (18–20 in)
 - c. 836 — 0.5–0.6 m (20–24 in)

Layers may be placed thicker however; density will be reduced no matter how many passes the compactor performs.

Below is a Layer Thickness chart based on MSW and 4 passes by an 836.

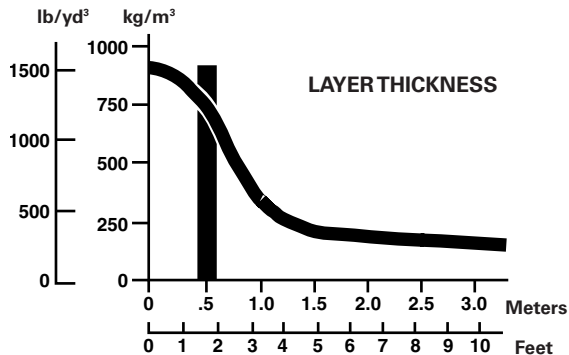

2. Developing a Pattern and Running Proper Passes — Maximum compaction density is obtained by putting the waste down in proper layer height, running a proper pattern and going over the waste with the proper number of passes. Those operators who develop a pattern, (starting from one side of the working face and running passes over entire area that waste has been layered in a logical sequence) and run proper amount of passes, normally obtain high density. In the past, it was said “that 3–5 passes is maximum to achieve highest density. Any more passes does not justify the added fuel and maintenance for the incremental gain in density.” Again, through testing and computer modeling, it has been noted that running an extra 1–2 passes diagonally (45 degrees) over the waste after the first 4 passes, can achieve higher density through ‘shredding and knitting’ the waste together (less cover soil/ADC could also be used due to the blending of the waste). In many countries, the ‘diversion’ of compost and biodegradable materials leaves some waste streams very dry. Drier waste streams demand more passes than normal, (sometimes 5–8 passes,) so that the material can be shredded or broken down properly for best compaction density.

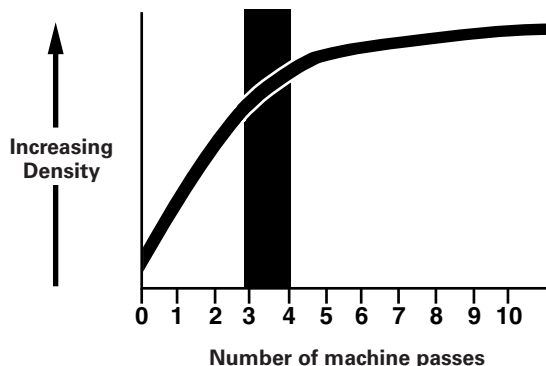

3. Slope — Maximum density is achieved by shredding and compression of material. Track-Type Tractors and Track Loaders achieve highest density on a 3:1 or less slope. The dynamics of track and gravity working together help shred material into smaller pieces. Although Landfill Compactors can work on steeper than 4:1 slopes, their best density is realized at 4:1 or less. The flatter the slope the better the density. The weight of the compactor is more efficiently utilized and concentrated on flatter slopes. Slight slopes sometimes add higher density due to the shearing stress that aids in shredding and blending of materials. Depending on degree of slope and whether working with another machine, (track-type tractor, dozer, or compactor) fuel use can sometimes be better uphill or downhill. Of course production is always better downhill. Again, depending on type of material and slope, tip selection for the compactor should be taken into consideration.

COMPACTION COMPARISON ESTIMATE

The following graph may be used as a rule of thumb for the compaction ranges of landfill machines assuming the proper operating technique is employed. (The mid ranges of each graph is assuming average waste stream and average operator.)

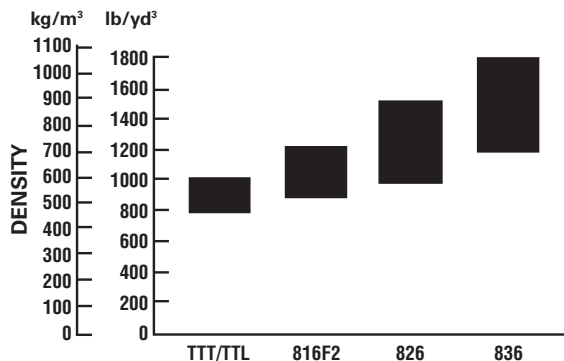

With correct operating procedures, tip/track/tool selection, and finally machine selection, density can be increased. An example of how increased density can increase landfill life is depicted in the next charts.

EXAMPLE OF INCREASED COMPACTION ON POTENTIAL LANDFILL LIFE

Landfill refuse capacity	1 530 000 m ³ (2,000,000 yd ³)	
Operating days	260	
Daily volume	365 metric tons (400 tons)	
Yearly volume	94 328 metric tons (104,000 tons)	
Compaction	Landfill Life	Gain
590 kg/m ³ 1000 lb/yd ³	9.6 years	0
710 kg/m ³ 1200 lb/yd ³	11.5 years	1.9 years
830 kg/m ³ 1400 lb/yd ³	13.4 years	3.8 years
950 kg/m ³ 1600 lb/yd ³	15.3 years	5.7 years
1070 kg/m ³ 1800 lb/yd ³	17.2 years	7.6 years

COMPACTOR PRODUCTION GUIDELINES

Model	Metric Tons/hr	U.S. Tons/hr
836K	140	135
826K	120	115
816F2	65	65

Parameters for the above: MSW, 4 passes, 18–30 m (60–100 ft) push distance, 4:1–5:1 slope, good operator.

All models are making 3 to 4 passes.

A pass is defined as: A machine traveling over the refuse one time in one direction on flat ground.

Adverse (uphill) or favorable (downhill) grades, deep layered waste, hard to handle waste, etc., will affect the above production figures.

(For tons/day — multiply by the amount of hours the machine will work in a days time.)

- Weather Conditions — Inclement weather affects production and density. Equipping machines with the proper track shoe or wheels and tips for the typical climate it works in will increase production and density while decreasing costs.
- Supplemental Tasks — There are a wide variety of tasks to be performed daily on a landfill. Understanding the ‘supplemental’ tasks that a machine might be asked to perform daily is paramount to adding the work tool(s) and right sizing the machine. For example, will the machine be required to perform site clearing, asked to build or maintain access roads, excavate cover soil, etc.? Logical choices of machines could change according to type of tasks and versatility required.
- Budget — Smaller landfill operations with limited budgets may have to consider single machine versatility ahead of specialized machines or multiple units.
- Growth — Population growth or added contracts can both increase and change inbound refuse. Future increases/decreases in refuse, type of material, density of material, etc., must be considered to properly pick tools and size machines.

LANDFILL ESTIMATING

Example Problem #1

A professional engineer has developed a small, rural landfill master plan. The local legislative regulatory agency has approved the plan and site.

Assume:

Waste generation: 2.04 kg/day (4.5 lb/day) per person

Waste collection: 6 days/week

Topography: flat

Land availability:

area has several suitable sites at nominal price

Population served: 30,000

Projected population in 3 years: 40,000

Current daily refuse volume: ?

Type of refuse: mostly household, some commercial

Operation: propose 8 hours/day, 5½ days/week

Present equipment: none — new site

What would your comments and recommendations be on the following:?

- Probable amount of refuse generated daily?
- Type of machine for the proposed Landfill?
- Size of machine for the proposed Landfill?

Solution

- The current incoming waste stream can be determined to be 2.04 kg/day (4.5 lb/day) per person × 30,000 people = 61.2 metric tons (67.5 tons) daily. You must now multiply that daily generation rate by 7 for the total weekly generation, and divide by the number of days that the waste is collected (6). Therefore, your waste collection per day will be (61.2 tons/day × 7 days)/6 days of collection = 71.4 metric tons (78.7 tons) collected daily.

The same equation can be used to determine the three year projected waste stream of 40,000 residents to be 81.6 metric tons (90 tons) generated daily, 95.2 metric tons (105 tons) collected each day.

- Track loader — excavating ability, single machine application based on tonnage requirements.
- 953C handle current refuse, and has extra capacity for future growth. Small compactor if additional compaction is required.

Example Problem #2

Existing landfill has been in operation for several years.

Assume:

Type of operation: area fill

Cover material: suitable material within 90 m (300 ft)

Current daily refuse volume: 500 metric tons (550 tons)

Anticipated daily refuse volume in 3 years:

680 metric tons (750 tons)

Type of refuse: household, commercial, large amount of brush and building demolition debris

Land availability: limited, very expensive

Available Refuse Volume: 3 249 125 m³ (4,250,000 yd³)

Operation: 8 hours/days, 5½ days/week

Present equipment: D8 (3 years old)

What would your comments and recommendations be on the following:

- What range of in-place densities could be expected using a track-type tractor; a Cat steel wheeled landfill compactor?
- What effect does machine selection have on site life?
- What are the advantages and limitations of steel wheeled landfill compactors?
- What are the advantages and limitations of track-type units?
- How many machines should be used on the site?
- What type should they be?
- What size should they be?

Solution

- a. The Track-Type Tractor will achieve 475 to 595 kg/m³ (800 to 1000 lb/yd³) in-place density. The Cat steel wheeled landfill compactor will achieve 595 to 830 kg/m³ (1000 to 1400 lb/yd³) in-place density.
- b. There are 3 249 125 m³ (4,250,000 yd³) available. 500 metric tons (550 tons) per day is how many m³ (yd³)? Assume a minimum density of 475 kg/m³ (800 lb/yd³).

$$500 \text{ metric tons/day} \times \frac{1000 \text{ kg/metric ton}}{475 \text{ kg/m}^3} = 1052 \text{ m}^3/\text{day}$$

$$550 \text{ tons/day} \times \frac{2000 \text{ lb/ton}}{800 \text{ lb/yd}^3} = 1375 \text{ yd}^3/\text{day}$$

$$5.5 \text{ days/week} \times 52 \text{ weeks/year} = 286 \text{ days/year}$$

$$\text{Yearly volume: } 1052 \times 286 = 300\,872 \text{ m}^3$$

$$1375 \times 286 = 393,250 \text{ yd}^3$$

Landfill life at this density:

$$\frac{3\,250\,000 \text{ m}^3}{300\,872 \text{ m}^3/\text{year}} = \frac{4,250,000 \text{ yd}^3}{393,250 \text{ yd}^3/\text{year}} = 10.8 \text{ years}$$

Similar calculations are performed to generate the following tables.

500 METRIC TONS/DAY (550 TONS/DAY)

Density		Landfill Life (years)
kg/m ³	lb/yd ³	
475	800	10.8
595	1000	13.5
715	1200	16.2
835	1400	18.9
950	1600	21.6

680 METRIC TONS/DAY (750 TONS/DAY)

Density		Landfill Life (years)
kg/m ³	lb/yd ³	
475	800	7.9
595	1000	9.9
715	1200	11.9
835	1400	13.9
950	1600	15.9

From the tables we determine that a track-type tractor, at 500 metric tons per day (550 tons/day), will provide 13.5 landfill life years at 595 kg/m³ (1000 lb/yd³). Compaction will extend that life 5.4 years to 18.9 years at 835 kg/m³ (1400 lb/yd³).

Proper compaction techniques are necessary to achieve the higher refuse densities and increase landfill life.

- c. Advantages: Provides highest compaction densities extending landfill life.

Limitations: Specialty unit designed to spread and compact — does not excavate virgin material economically, but can handle stockpile cover material.

- d. Advantages: most versatile unit, well suited to site preparation, finishing and access road construction and maintenance; all weather machines with excellent tractive ability.

Limitation: compaction — cannot achieve the in-place refuse densities of the specialized landfill compactors.

- e. Minimum of two. Additional equipment would depend on supplemental tasks.
- f. Track-type tractor — for earthmoving and refuse spreading work; steel wheeled compactor-quantity of refuse and land cost would justify.
- g. D8 — keeping existing unit; D9 — when new tractor is necessary; 826H — with large amount of demolition debris and brush and projected increase in tonnage would justify 826H over 816F2.

NOTE: Ballasting the wheels on Cat Landfill Compactors to increase machine weight and achieve higher compaction densities is not recommended. Landfills are high rimpull applications. Ballasting the wheels will significantly increase machine weight but decrease overall performance when traveling on the fill. The additional weight of ballasted wheels will also result in reduced final drive life.

GREEN WASTE/COMPOSTING

Green waste and compostable material are being eliminated from most landfills. Composting is normally regulated at the state level in the U.S., and on higher governmental levels within the EU. Green and compostable waste is realized as: soil amendments, bio fuels, and incinerated energy sources. With more and more green waste and compostable material being diverted from the waste stream, tools and machines that can handle this type of waste are needed. Most commonly used are wheel loaders and excavators (wheeled/tracked) of all sizes. Most are equipped with coupler for versatility of different tools. Work tools utilized range from grapple buckets, multi-purpose buckets, and light material buckets for wheel loaders, to waste grapples, orange peel grapples, and sorting grabs for excavators. It is normal, in some areas, for regulations to request added cab filtration and protection from composting airborne debris.

WASTE RELATED ENERGY PRODUCTION

There are a variety of ways to produce energy from waste. C&D landfills, green waste, biodigesters, and composting facilities, will process wood, organics and other products for: gasification, bio fuels, possible incineration, and energy from newer technologies.

LANDFILLS — RENEWABLE POWER WITH LANDFILL GAS

Landfill gas, composed mostly of methane and carbon dioxide, is produced naturally as organic waste decomposes in landfills. Driven by mandate of carbon reduction goals, modern sanitary landfills capture this gas for use as a renewable fuel in specially configured Cat landfill gas generator sets. These systems deliver reliable and environmentally sound electricity to the local community from 400 kW to 2 mW power nodes.

Please contact your local dealership, Waste representative, or *Cat.com* for more information.

Cat Waste Handling Track-Type Tractor modifications are purpose built and installed at the original manufacturing facility prior to shipment.

Features:

- **Hinged heavy duty radiator doors** are guarded to prevent excessive trash build-up. Quick release handles allow easy access for cleaning.
- **Final drive, pivot shaft, and idler seal guarding** helps prevent wire, cable and similar material from winding around components and damaging seals.
- **Striker bars for front, rear and ripper (all optional)** keep trash from damaging fenders, fuel and hydraulic tanks or other sheet metal.
- **Lighting protection.** Front lights are mounted on top of bulldozer lift cylinders. Rear lights are ROPS mounted.
- **Waste Handling Arrangement radiator** with 6 fins/inch.
- **Elevated sprocket** removes final drives from wear environment and eliminates impact loading for extended power train life. D7E includes D10-size bearings to ensure long life.
- **Sheet metal guarding** near track and on dozer tilt hoses.
- **Fuel tank guards** keep trash from damaging fuel and hydraulic tanks or other sheet metal.
- **Final drive guards** — guard installed over the final drives to help prevent wire wrap. Guards include inspection plates, not available for D6N.
- **Reversible hydraulic demand fan** required for D6T, D7E, D8T, D9T, not available for D6N.
- **Heavy duty steps and grab handles** resist damage from landfill debris.
- **Center hole track shoes (optional)** help minimize the effects of track packing during machine operation.
- **Blade trash racks (optional)** prevent blade spill-over and damage to cylinders or radiator guard. Increase productivity in waste handling.
- **Ducted alternator available on D6T, D8T, D9T** insures adequate current is available to maintain battery and operate accessories. Not required on D7E.
- **Elevated prescreener** to remove engine air inlet from debris environment. Larger surface area to resist plugging.
- **Precleaner** removes large particulates from incoming air before they reach the air filter, helps extend filter life. (Optional on D6T through D9T.)
- **ROPS mounted air conditioning** helps prevent condenser core plugging. Provides full utilization of jacket water cooling system by avoiding additional heat load from radiator mounted condenser.
- **Laminated thermal shields** cover the CEM inside the engine compartment, hot-side of the turbocharger, and the exhaust manifold. These shields reduce surface temperatures below the flash point of most common combustibles encountered.
- **Chassis Guards.**
- **Sealed belly guards.**
- **Perforated engine enclosures** standard on D6T, D7E, D8T, and D9T. This configuration is unavailable when Sound Suppression is ordered.
- **Carrier rollers** not recommended on elevated sprocket machines.

MODEL	D6N XL WH		D6N LGP WH	
Emission Standards	Tier 4 Final***		Tier 4 Final***	
Flywheel Power	111.8 kW	150 hp	111.8 kW	150 hp
Operating Weight (Power Shift Differential Steer)* SU Blade	—		—	
Engine Model	C6.6 ACERT™		C6.6 ACERT	
Rated Engine RPM	2200		2200	
No. of Cylinders	6		6	
Bore	105 mm	4.13"	105 mm	4.13"
Stroke	127 mm	5.0"	127 mm	5.0"
Displacement	6.6 L	403 in³	6.6 L	403 in³
Track Rollers (Each Side)	7		8	
Width of Standard Track Shoe	610 mm	2'0"	840 mm	2'9"
Length of Track on Ground	2581 mm	8'6"	3117 mm	10'3"
Ground Contact Area (with Std. Shoe)	3.15 m ²	4882 in²	5.24 m ²	8122 in²
Track Gauge	1.89 m	6'2"	2.16 m	7'1"
GENERAL DIMENSIONS:				
Height (Stripped Top)**	—		—	
Height (To Top of ROPS Canopy)	3.04 m	10'0"	3.14 m	10'4"
Height (To Top of ROPS Cab)	3.10 m	10'2"	3.20 m	10'6"
Overall Length (without Blade)	3.74 m	12'3"	4.17 m	13'8"
with S Blade	—		—	
with SU Blade	5.16 m	16'11"	—	
with VPAT Blade	4.90 m	16'1"	5.37 m	17'7"
Width (over Trunnion)	2.63 m	8'8"	—	
Width (without Trunnion — Std. Track)	2.50 m	8'2"	—	
Ground Clearance	394 mm	1'4"	507 mm	1'8"
Blade Types and Widths:				
Straight	—		—	
Semi-U	3.19 m	10'6"	—	
VPAT (Variable pitch, angle, and tilt) straight	3.27 m	10'9"	4.08 m	13'5"
Fuel Tank Refill Capacity	299 L	79 U.S. gal	299 L	79 U.S. gal

*Operating Weight includes ROPS canopy, operator, lubricants, coolant, full fuel tank, hydraulic controls and fluid, straight dozer with tilt, horn, back-up alarm, retrieval hitch and front pull hook.

**Height (stripped top) — without ROPS canopy, exhaust, precleaner, seat back or other easily removed encumbrances.

***Meets U.S. EPA Tier 4 Final, EU Stage IV and Japan 2014 (Tier 4 Final) emission standards.

MODEL	D6T WH		D6T XL WH	
	Tier 4 Final***		Tier 4 Final***	
Emission Standards				
Flywheel Power	149 kW	200 hp	149 kW	200 hp
Operating Weight (Power Shift Differential Steer)* SU Blade	20 580 kg	45,370 lb	21 600 kg	47,620 lb
Engine Model	C9 ACERT		C9 ACERT	
Rated Engine RPM: Power Shift	1850		1850	
No. of Cylinders	6		6	
Bore	112 mm	4.4"	112 mm	4.4"
Stroke	149 mm	5.9"	149 mm	5.9"
Displacement	8.8 L	537 in ³	8.8 L	537 in ³
Track Rollers (Each Side)	6		7	
Width of Standard Track Shoe	560 mm	22"	560 mm	22"
Length of Track on Ground	2.61 m	8'7"	2.81 m	9'3"
Ground Contact Area (with Std. Shoe)	2.92 m ²	4531 in ²	3.15 m ²	4878 in ²
Track Gauge	1.88 m	74"	1.88 m	74"
GENERAL DIMENSIONS:				
Height (Stripped Top)**	2.40 m	7'11"	2.40 m	7'11"
Height (To Top of ROPS Canopy)	3.11 m	10'2"	3.11 m	10'2"
Height (To Top of ROPS Cab)	3.11 m	10'2"	3.11 m	10'2"
Overall Length (without Blade)	3.85 m	12'7"	3.85 m	12'7"
with SU Blade	5.08 m	16'8"	5.33 m	17'6"
with Angle Blade	5.00 m	16'5"	5.21 m	17'1"
Width (over Trunnion)	2.64 m	8'8"	2.64 m	8'8"
Width (without Trunnion — Std. Track)	2.44 m	8'0"	2.44 m	8'0"
Ground Clearance	384 mm	1'3"	384 mm	1'3"
Blade Types and Widths:				
Angle Straight	4.16 m	13'8"	4.16 m	13'8"
Full 25° Angle	3.77 m	12'5"	3.77 m	12'5"
Semi-U	3.26 m	10'8"	3.26 m	10'8"
Fuel Tank Refill Capacity	425 L	112 U.S. gal	425 L	112 U.S. gal

*Operating Weight includes ROPS canopy, operator, lubricants, coolant, full fuel tank, hydraulic controls and fluid, straight dozer with tilt, horn, back-up alarm, retrieval hitch, front pull hook and standard WHA Attachments.

**Height (stripped top) — without ROPS canopy, exhaust, precleaner, seat back or other easily removed encumbrances.

***Meets Tier 4 Final, Stage IV and Japan 2014 (Tier 4 Final) emission standards.

MODEL	D6T XL WH		D6T XW WH		D6T LGP WH	
Emission Standards	Tier 4 Final****		Tier 4 Final****		Tier 4 Final****	
Flywheel Power	151 kW	202 hp	151 kW	202 hp	151 kW	202 hp
Operating Weight:*						
Power Shift Differential Steer	23 236 kg	51,226 lb	24 221 kg	53,286 lb	24 900 kg	50,895 lb
VPAT	25 420 kg	56,050 lb	26 535 kg	58,500 lb	27 015 kg	59,557 lb
Engine Model	C9.3 ACERT		C9.3 ACERT		C9.3 ACERT	
Rated Engine RPM	2000		2000		2000	
No. of Cylinders	6		6		6	
Bore	115 mm	4.5"	115 mm	4.5"	115 mm	4.5"
Stroke	149 mm	5.9"	149 mm	5.9"	149 mm	5.9"
Displacement	9.3 L	567 in³	9.3 L	567 in³	9.3 L	567 in³
Track Rollers (Each Side)	7		7		8	
Width of Standard Track Shoe	560 mm	22"	760 mm	30"	915 mm	36"
VPAT	560 mm	22"	710 mm	28"	785 mm	31"
Length of Track on Ground	2.86 m	9'5"	2.86 m	9'5"	3.27 m	10'9"
VPAT	2.86 m	9'5"	3.27 m	10'9"	3.27 m	10'9"
Ground Contact Area (with Std. Shoe)	3.20 m ²	4929 in²	4.35 m ²	6738 in²	5.98 m ²	9275 in²
VPAT	3.20 m ²	4929 in²	4.64 m ²	7197 in²	5.13 m ²	7956 in²
Track Gauge	1.88 m	74"	2.03 m	80"	2.29 m	90"
VPAT	2.13 m	84"	2.29 m	90"	2.29 m	90"
GENERAL DIMENSIONS:						
Height** (Stripped Top***)	2.46 m	8'1"	2.46 m	8'1"	2.51 m	8'3"
VPAT	2.46 m	8'1"	2.51 m	8'3"	2.51 m	8'3"
Height** (To Top of ROPS Canopy)	3.11 m	10'2"	3.11 m	10'2"	3.16 m	10'4"
VPAT	3.11 m	10'2"	3.16 m	10'4"	3.16 m	10'4"
Height** (To Top of ROPS Cab)	3.15 m	10'4"	3.15 m	10'4"	3.20 m	10'6"
VPAT	3.15 m	10'4"	3.20 m	10'6"	3.20 m	10'6"
Overall Length (without Blade)	3.89 m	12'9"	3.89 m	12'9"	4.25 m	13'11"
VPAT	3.89 m	12'9"	4.25 m	13'11"	4.25 m	13'11"
with S Blade	—	—	—	—	5.50 m	18'1"
with SU Blade	5.33 m	17'6"	5.33 m	17'6"	—	—
with VPAT Blade	5.39 m	17'8"	5.53 m	18'2"	5.53 m	18'2"
with Angle Blade	5.21 m	17'1"	5.29 m	17'4"	5.81 m	19'1"
Width (over Trunnion)	2.64 m	8'8"	2.95 m	9'8"	3.43 m	11'3"
Width (without Trunnion — Std. Track)	2.44 m	8'0"	2.79 m	9'2"	3.21 m	10'6"
VPAT	2.69 m	8'10"	3.00 m	9'10"	3.08 m	10'1"
Ground Clearance**	384 mm	1'3"	384 mm	1'3"	434 mm	1'5"
VPAT	384 mm	1'3"	434 mm	1'5"	434 mm	1'5"
Blade Types and Widths:						
Straight	—	—	—	—	4.06 m	13'4"
Angle Straight	4.16 m	13'8"	4.52 m	14'10"	5.07 m	16'8"
Full 25° Angle	3.77 m	12'5"	4.11 m	13'6"	4.63 m	15'2"
Semi-U	3.26 m	12'8"	3.56 m	11'8"	—	—
VPAT Straight	3.88 m	12'9"	4.16 m	13'8"	4.16 m	13'8"
VPAT Full 24° Angle	3.49 m	11'5"	3.72 m	12'2"	3.72 m	12'2"
Fuel Tank Refill Capacity	425 L	112 U.S. gal	425 L	112 U.S. gal	425 L	112 U.S. gal

*Operating Weight includes cab, operator, lubricants, coolant, full fuel tank, standard track, hydraulic controls and fluid, SU blade, drawbar, and standard WHA attachments.

**Dimensions measured from ground line. Add grouser height for total dimension on hard surfaces.

***Height (stripped top) — without ROPS canopy, exhaust, seat back or other easily removed encumbrances.

****Meets Tier 4 Final, Stage IV and Japan 2014 (Tier 4 Final) emission standards.

MODEL	D7E WH		D7E LGP WH		D8R WH		D8T WH	
Emission Standards	Tier 4 Final ¹		Tier 4 Final ¹		Tier 2 Equivalent ²		Tier 3 Equivalent ³	
Flywheel Power	—		—		228 kW 305 hp		231 kW 310 hp	
Advertised Flywheel Power	175 kW	235 hp	175 kW	235 hp	—		—	
Operating Weight:*								
Electric Drive Differential Steer	28 908 kg	63,730 lb	31 116 kg	68,600 lb	—		—	
Power Shift Differential Steer	—		—		37 630 kg	82,880 lb	38 660 kg	85,150 lb
Engine Model	C9.3 ACERT		C9.3 ACERT		3406ETA		C15 ACERT	
Rated Engine RPM	—		—		2100		1850	
Advertised Engine RPM	1700		1700		—		—	
No. of Cylinders	6		6		6		6	
Bore	115 mm	4.5"	115 mm	4.5"	137 mm	5.4"	137 mm	5.4"
Stroke	149 mm	5.9"	149 mm	5.9"	165 mm	6.5"	172 mm	6.75"
Displacement	9.3 L	567 in ³	9.3 L	567 in ³	14.6 L	893 in ³	15.2 L	928 in ³
Track Rollers (Each Side)	7		8		8		8	
Width of Standard Track Shoe	610 mm	24"	915 mm	36"	560 mm	1'10"	560 mm	1'10"
Length of Track on Ground	3.02 m	9'11"	3.45 m	11'4"	3.21 m	10'6"	3.21 m	10'6"
Ground Contact Area (with Std. Shoe)	3.68 m ²	5698 in ²	6.31 m ²	9792 in ²	3.57 m ²	5544 in ²	3.58 m ²	5544 in ²
Track Gauge	1.98 m	6'6"	2.29 m	7'6"	2.08 m	6'10"	2.08 m	6'10"
GENERAL DIMENSIONS:								
Height (Stripped Top)**	—		—		2.67 m	8'9"	2.67 m	8'9"
Height (To Top of ROPS Canopy)	—		—		3.51 m	11'6"	3.46 m	11'4"
Height*** (To Top of ROPS Cab)	3.32 m	10'11"	3.32 m	10'11"	3.45 m	11'3"	3.46 m	11'4"
Overall Length (without Blade)	4.88 m	16'0"	4.88 m	16'0"	4.93 m	16'2"	4.64 m	15'3"
with S Blade	5.86 m	19'3"	5.56 m	18'3"	—		6.09 m	20'0"
with SU Bladet	6.07 m	19'11"	—		6.91 m	22'8"	6.91 m	22'8"
Width (over Trunnion)	2.88 m	9'5"	3.42 m	11'3"	3.05 m	10'0"	3.05 m	10'0"
Width (without Trunnion — Std. Shoe)	2.59 m	8'6"	3.2 m	10'6"	2.70 m	8'8"	2.64 m	8'8"
Ground Clearance	472 mm	18.6"	472 mm	18.6"	606 mm	1'11"	618 mm	2'4"
Blade Types and Widths:								
Straight	3.9 m	12'10"	4.54 m	14'11"	—		—	
Angle Straight	—		—		4.99 m	16'4"	4.99 m	16'4"
Full 25° Angle	—		—		4.52 m	14'10"	4.52 m	14'10"
Universal	3.99 m	13'1"	—		4.26 m	14'0"	4.26 m	14'0"
Semi-U	3.71 m	12'2"	—		3.94 m	12'11"	3.94 m	12'11"
Fuel Tank Refill Capacity	409 L	108 U.S. gal	409 L	108 U.S. gal	625 L	165 U.S. gal	643 L	170 U.S. gal

*Operating Weight for D7E WH and D7E LGP WH includes cab, operator, lubricants, coolant, full fuel tank, standard track, hydraulic controls and fluid, SU blade and drawbar.

Operating Weight for D8R WH includes ROPS cab, operator, lubricants, coolant, full fuel tank, standard track, hydraulic controls and fluid, SU blade with trash rack, retrieval hitch, front pull hook, and track guides.

Operating Weight for D8T WH includes ROPS canopy, operator, lubricants, coolant, full fuel tank, hydraulic controls and fluids, SU blade with tilt, back-up alarm, seat belts, lights, rigid drawbar and front towing device.

— D8T WH equipped with track guides, ROPS/FOPS cab, and SU blade.

**Height (stripped top) — without ROPS canopy, exhaust, seat back or other easily removed encumbrances.

***Dimensions for D7E LGP WH measured from ground line. Add grouser height for total dimension on hard surfaces.

†D8R WH and D8T WH include drawbar.

¹Meets Tier 4 Final, Stage IV and Japan 2014 (Tier 4 Final) emission standards.

²Meets Tier 2, Stage II, Japan 2001 (Tier 2) equivalent emission standards.

³Meets Tier 3, Stage IIIA, Japan 2006 (Tier 3) equivalent emission standards.

MODEL	D8T WH		D9T WH		D9T WH	
Emission Standards	Tier 4 Final¹		Tier 2 Equivalent or Tier 3 Equivalent²		Tier 4 Final¹	
Flywheel Power	233 kW	312 hp	306 kW	410 hp	325 kW	436 hp
Operating Weight:*						
Power Shift Differential Steer	39 331 kg	86,710 lb	49 761 kg	109,705 lb	50 109 kg	110,471 lb
Engine Model	C15 ACERT		C18 ACERT		C18 ACERT	
Rated Engine RPM	1900		1833		1800	
No. of Cylinders	6		6		6	
Bore	137 mm	5.4"	145 mm	5.7"	145 mm	5.7"
Stroke	172 mm	6.75"	183 mm	7.2"	183 mm	7.2"
Displacement	15.2 L	928 in³	18.1 L	1106 in³	18.1 L	1106 in³
Track Rollers (Each Side)	8		8		8	
Width of Standard Track Shoe	610 mm	2'0"	610 mm	2'0"	610 mm	2'0"
Length of Track on Ground	3.21 m	10'6"	3.47 m	11'5"	3.47 m	11'5"
Ground Contact Area (with Std. Shoe)	3.91 m ²	6062 in²	4.24 m ²	6569 in²	4.24 m ²	6569 in²
Track Gauge	2.08 m	6'10"	2.25 m	7'5"	2.25 m	7'5"
GENERAL DIMENSIONS:						
Height (Stripped Top)**	2.67 m	8'9"	3.69 m	12'1"	3.69 m	12'1"
Height (To Top of ROPS Canopy)	3.46 m	11'4"	4.00 m	13'1"	4.00 m	13'1"
Height (To Top of ROPS Cab)	3.46 m	11'4"	3.82 m	12'6"	3.82 m	12'6"
Overall Length (without Blade and without Drawbar)	4.64 m	15'3"	4.91 m	16'1"	4.91 m	16'1"
with SU Landfill Blade***	6.09 m	20'0"	6.86 m	22'5"	6.86 m	22'5"
Width (over Trunnion)	3.06 m	10'0"	3.30 m	10'8"	3.30 m	10'8"
Width (without Trunnion — Std. Shoe)	2.64 m	8'8"	2.88 m	9'5"	2.88 m	9'5"
Ground Clearance	618 mm	2'4"	496 mm	1'7"■	496 mm	1'7"■
Blade Types and Widths:						
Angle Straight	4.99 m	16'4"	—	—	—	—
Full 25° Angle	4.52 m	14'10"	—	—	—	—
Universal	4.26 m	14'0"	4.65 m	15'3"	4.65 m	15'3"
Semi-U	3.94 m	12'11"	4.31 m	14'2"	4.31 m	14'2"
Fuel Tank Refill Capacity	643 L	170 U.S. gal	889 L	235 U.S. gal	821 L	217 U.S. gal
DEF Tank Capacity	—	—	—	—	36 L	9.5 U.S. gal

*Operating Weight includes ROPS canopy, operator, lubricants, coolant, full fuel tank, hydraulic controls and fluids, SU blade with tilt, back-up alarm, seat belts, lights, rigid drawbar and front towing device.

— D8T WH equipped with track guides, ROPS/FOPS cab, and SU blade.

— D9T WH equipped with track guides, ROPS/FOPS cab, single shank ripper and SU blade.

**Height (stripped top) — without ROPS canopy, exhaust, seat back or other easily removed encumbrances. Dimensions measured from ground line. Add grouser height for total dimension on hard surfaces.

***Includes drawbar.

■ ISO 6746 — Dimensions measured from ground line to lowest point under machine. Add grouser height for total dimension on hard surfaces.

¹ Meets Tier 4 Final, Stage IV and Japan 2014 (Tier 4 Final) emission standards.

² Meets Tier 2, Stage II, Japan 2001 (Tier 2) equivalent or Tier 3, Stage IIIA, Japan 2006 (Tier 3) equivalent emission standards.

MODEL	D6N XL		D6N LGP		D6T WH	
	6VPAT XL		6VPAT LGP		6SU	
Type	Variable Pitch Power Angle and Tilt		Variable Pitch Power Angle and Tilt		Semi Universal	
Blade Capacities with Trash Rack*	6.4 m ³	8.37 yd ³	4.6 m ³	6.02 yd ³	10.9 m ³	14.3 yd ³
Weight, Shipping** (Dozer)	1206 kg	2659 lb	1338 kg	2950 lb	3026 kg	6657 lb
Tractor and Dozer Dimensions:						
A Length (Blade Straight)	4903 mm	16'1"	5369 mm	17'7"	5.31 m	17'5"
Blade Dimensions:						
B Width (including std. end bits)	3272 mm	10'9"	4082 mm	13'5"	3.26 m	10'8"
C Height	1702 mm	5'7"	1447 mm	4'9"	2019 mm	6'7"
D Max. Digging Depth	374 mm	1'2.7"	387 mm	1'3.2"	453 mm	1'6"
E Ground Clearance @ Full Lift	994 mm	3'3.1"	1074 mm	3'6.3"	1204 mm	3'11"
F Manual Tilt	—		—		—	
G Max. Pitch	+2.8° to -4.7°		+2.8° to -4.7°		+5.6° to -5.2°	
H Max. Hydraulic Tilt	584 mm	1'11"	658.6 mm	2'1.9"	811 mm	2'8"
J Hydraulic Tilt (Manual Brace Centered)	—		—		455 mm	1'6"

*Blade capacities as determined by SAE J1265.

Notice that the capacity of the U-blade is the volume carried by a straight blade of the same dimensions plus the volume included in the "cup" of the U-blade. It is intended for **relative comparisons of dozer sizes**, and not for predicting capacities or productivities in actual field conditions.

**Shipping Weight — Total Bulldozer Arrangement includes: Blade, push arms or C-frame, braces, cylinders, lines, trunnions and lift cylinder mountings.

MODEL	D6T WH and D6T Tier 4 Interim/Stage IIIB WH					
	6SU XL		6S LGP		6SU XW	
Type	Semi Universal		Straight		Semi Universal	
Blade Capacities*	10.9 m ³	14.3 yd ³	9.4 m ³	12.3 yd ³	11.3 m ³	14.7 yd ³
Weight, Shipping** (Dozer)	3026 kg	6657 lb	2840 kg	6262 lb	3181 kg	7013 lb
Tractor and Dozer Dimensions:						
A Length (Blade Straight)	5.31 m	17'5"	5.5	18'1"	5.31 m	17'5"
Blade Dimensions:						
B Width (including std. end bits)	3.26 m	10'8"	4.08 m	13'4"	3.56 m	11'8"
C Height	2019 mm	6'7"	1764 mm	5'9"	2019 mm	6'7"
D Max. Digging Depth	453 mm	1'6"	658 mm	2'2"	453 mm	1'6"
E Ground Clearance @ Full Lift	1204 mm	3'11"	1088 mm	3'7"	1204 mm	3'11"
F Manual Tilt	—		—		—	
G Max. Pitch	+5.6° to -5.2°		+4.4° to -4.4°		+5.6° to -5.2°	
H Max. Hydraulic Tilt	811 mm	2'8"	747 mm	2'5"	811 mm	2'8"
J Hydraulic Tilt (Manual Brace Centered)	455 mm	1'6"	421 mm	1'5"	455 mm	1'6"

*Blade capacities as determined by SAE J1265. Model 6SU XL blade capacities with trash rack.

Notice that the capacity of the U-blade is the volume carried by a straight blade of the same dimensions plus the volume included in the "cup" of the U-blade. It is intended for **relative comparisons of dozer sizes**, and not for predicting capacities or productivities in actual field conditions.

**Shipping Weight — Total Bulldozer Arrangement includes: Blade, push arms or C-frame, braces, cylinders, lines, trunnions and lift cylinder mountings.

MODEL	D7E LGP WH				D8T WH			
	7S		8SU		8U		8SU LGP	
Type								
Blade Capacities*	19.1 m ³	25 yd³	20 m ³	26.1 yd³	24.8 m ³	32.4 yd³	21.1 m ³	27.6 yd³
Dozer Weight**	4026 kg	8875 lb	5466 kg	12,025 lb	6313 kg	13,888 lb	5624 kg	12,400 lb
Tractor and Dozer Dimensions:								
Length Blade Straight	6.28 m	20'7"	6.39 m	21'0"	6.79 m	22'3"	6.39 m	21'0"
Blade Dimensions:								
Width including std. end bits	4.58 m	15'0"	3.94 m	12'11"	4.26 m	14'0"	4.52 m	14'10"
Height	2418 mm	7'11"	2464 mm	8'1"	2515 mm	8'3"	2465 mm	8'1"
Maximum Dig Depth	640 mm	25 in	582 mm	1'10.9"	582 mm	1'10.9"	582 mm	1'10.9"
Ground Clearance at full raise	1285 mm	4'3"	1231 mm	4'0.5"	1231 mm	4'0.5"	1231 mm	4'1"
Maximum Hydraulic Tilt	470 mm	1'7"	951 mm	3'1.4"	1028 mm	3'4.5"	—	

*Blade capacities, weights and heights include 1075 mm (3'6") trash rack on D7E LGPWH blades and 762 mm (2'6") trash rack on D8TWH blades.

**Total bulldozer arrangement includes blade with trash rack, pusharms, braces, cylinders, lines, trunnions and lift cylinder mountings.

MODEL	D9T WH			
	9SU		9U	
Type				
Blade Capacities*	28.8 m ³	37.6 yd³	33.5 m ³	43.8 yd³
Dozer Weight**	8051 kg	17,749 lb	8704 kg	19,189 lb
Tractor and Dozer Dimensions:				
Length Blade Straight	6.84 m	22'5"	7.18 m	23'7"
Blade Dimensions:				
Width including std. end bits	4.31 m	14'2"	4.65 m	15'3"
Height	2845 mm	9'4"	2845 mm	9'4"
Maximum Dig Depth	606 mm	1'11.9"	606 mm	1'11.9"
Ground Clearance at full raise	1422 mm	4'8"	1422 mm	4'8"
Maximum Hydraulic Tilt	940 mm	3'1"	1014 mm	3'3.9"

*Blade capacities, weights and heights include 914 mm (3'0") trash rack on D9TWH blades.

**Total bulldozer arrangement includes blade with trash rack, pusharms, braces, cylinders, lines, trunnions and lift cylinder mountings.

Features:

- **Unmatched versatility** — excavates, loads, carries, covers, dozes, spreads, compacts, shreds, sorts, grapples — a true all purpose machine. Performs well as a one-machine fleet, a support machine or an all-around backup unit.
- **Demolition applications** — The Waste Handling Arrangement (963D and 973D Waste Extreme Service) can also be used in demolition or demolition transfer stations when properly equipped with the extra guarding required for this severe environment.
- **Special guard** protects the final drive seals, pivot shafts and idlers from debris that can wrap around and damage these components.
- **Cat Turbine Precleaner** with prescreener to prevent airborne debris from clogging engine air intake.
- **Additional heavy duty guarding** helps protect sheet metal and machine components from damage in waste handling applications.
- **Improved serviceability** — swing open doors, guards and air coolers give quick access for cleaning debris and servicing.
- **Hinged, heavy duty radiator guard** with quick release “T” handles allows for easy access to clean the radiator.
- **Debris Barrier Package** protects machine from material entering engine and other compartments.
- **Lamp guard group** protects front and rear lamps with bolt on grids.
- **Optional rear striker bars** keep trash from climbing the track and damaging fenders.
- **Optional final drive abrasion guards** are available in two-piece or four-piece sections to protect the final drive case from premature wear from abrasion or gouging.
- **Optional trapezoidal-shaped center hole track shoes** provide maximum traction. The center holes allow sprocket to punch out dirt and debris, best choice for landfill applications.
- **Hydraulic reversing fan (953D and 963D) or variable pitch cooling fan** (optional on 973D) manually or automatically changes direction to purge accumulated debris from the radiator.
- **Cab and Operator Comfort** — Standard air suspension seat, air conditioning, adjustable steering pedals, storage area, and excellent visibility enable the operator to be more comfortable in this application for better profitability.

MODEL	953D WH		963D WH		973D WH	
Emission Standards	Tier 3 Equivalent**		Tier 3 Equivalent**		Tier 3 Equivalent**	
Flywheel Power	110 kW	148 hp	141 kW	189 hp	196 kW	263 hp
Operating Weight*	15 595 kg	34,381 lb	21 000 kg	46,305 lb	29 555 kg	65,158 lb
Engine Model	C6.6 ACERT		C6.6 ACERT		C9 ACERT	
Rated Engine RPM	2000		2000		1900	
Bore	105 mm	4"	105 mm	4.13"	112 mm	4.41"
Stroke	127 mm	5"	127 mm	5"	149 mm	5.87"
No. Cylinders	6		6		6	
Displacement	6.6 L	402.7 in³	6.6 L	402.7 in³	8.8 L	537 in³
Speeds, Forward/Reverse:						
1st	0-10 km/h	0-6.2 mph	0-10 km/h	0-6.2 mph	0-11 km/h	0-6.8 mph
2nd	Infinitely		Infinitely		Infinitely	
3rd	Variable		Variable		Variable	
Hydraulic Cycle Time, Bucket Empty, in Seconds:						
Raise	6.1		5.9		6.5	
Dump	3.1		3.7		1.4	
Lower (Empty, Float Down)	3.2		2.2		2.7	
Total	—		—		10.6	
Track Rollers (Each Side)	6		6		7	
Width of Standard Track Shoes	480 mm	19"	550 mm	21.6"	550 mm	21.6"
Length of Track on Ground	2323 mm	91.4"	2543 mm	100.1"	2930 mm	115"
Ground Contact Area (with Standard Shoes)	2.3 m ²	3565 in²	2.8 m ²	4340 in²	3.22 m ²	4991 in²
Ground Pressure	65.5 kPa	9.5 psi	71.5 kPa	10.3 psi	90.0 kPa	13.0 psi
Ground Clearance	436 mm	17.2"	483 mm	19"	482 mm	18.9"
Track Gauge	1800 mm	71"	1850 mm	72.8"	2160 mm	85"
Width without Bucket	2280 mm	89.7"	2400 mm	94.5"	2710 mm	106.7"
Fuel Tank Refill Capacity	285 L	75.3 U.S. gal	336.5 L	88.8 U.S. gal	621 L	164 U.S. gal
Hydraulic System Refill Capacity	124 L	32.8 U.S. gal	166 L	43.8 U.S. gal	189 L	50 U.S. gal

*Includes GP landfill bucket with bolt-on adapters, long tips and segments.

See *Wheel Loader* section of this book for summary of S.A.E. Guidelines for Loader Specifications, to which Caterpillar adheres.

**Meets Tier 3, Stage IIIA, Japan 2006 (Tier 3) equivalent emission standards.

MULTI-PURPOSE LANDFILL BUCKETS

Machine Model	953D WH		963D WH		973D WH	
Capacity, rated (Refuse)	2.1 m ³	2.75 yd³	2.7 m ³	3.5 yd³	4.6 m ³	6 yd³
Capacity, rated (Earth)	1.5 m ³	2 yd³	1.8 m ³	2.4 yd³	2.7 m ³	3.53 yd³
Width	2536 mm	99.84"	2573 mm	101.30"	2946 mm	115.9"
Height	1677 mm	66.02"	1750 mm	68.90"	1944 mm	76.58"
Depth	1433 mm	56.41"	1537 mm	60.51"	1607 mm	63.3"
Teeth — Optional		8		8		8
Clearance @ 45° dump	2738 mm	9'0"	2870 mm	9'5"	3060 mm	120.5"
Reach @ 45° dump	961 mm	3'2"	1013 mm	3'4"	1261 mm	49.6"
Digging Depth	147 mm	5.7"	161 mm	6.3"		—
Weight (approx.)	1668 kg	3678 lb	2206 kg	4864 lb	3575 kg	7882 lb

GENERAL PURPOSE LANDFILL BUCKETS

Machine Model	953D WH		963D WH		973D WH	
Capacity, rated (Refuse)	2.3 m ³	3.0 yd³	3.1 m ³	4.1 yd³	4.9 m ³	6.41 yd³
Capacity, rated (Earth)	1.75 m ³	2.29 yd³	2.3 m ³	3.0 yd³	3.2 m ³	4.2 yd³
Width	2458 mm	96.77"	2612 mm	102.83"	2910 mm	114.6"
Height	1607 mm	63.2"	1778 mm	70"	1936 mm	76.2"
Depth	1450 mm	57.1"	1480 mm	58.3"	1491 mm	58.7"
Teeth — Optional		8		8		8
Clearance @ 45° dump	2855 mm	9'0"	3155 mm	10'4"	3261 mm	128.4"
Reach @ 45° dump	999 mm	3'3"	1147 mm	3'9"	1191 mm	46.9"
Digging Depth	85 mm	5.7"	161 mm	6.3"		—
Weight (approx.)	1266 kg	2792 lb	1888 kg	4163 lb	2320 kg	5115 lb

NOTE: 973D GP and MP landfill buckets are equipped with bolt-on segments and teeth general duty.

Features:

- **Caterpillar designed and manufactured power train** ... for optimum match, performance and efficiency. Responsive Cat diesel engine. Single-lever planetary power shift. All-wheel drive.
- **Center-point articulation** ... excellent maneuverability. Front and rear drums track, so material is chopped and compacted twice each pass.
- **Protective guarding** ... helps keep trash from damaging machine components.
- **Cat landfill blades** spread refuse and cover material ... built strong to handle the wide range of refuse encountered in landfills.
- **Operator comfort and convenience** ... sound suppressed cab with pressurized and filtered air circulation system. Adjustable suspension seat. Electronic Monitoring System and gauge package is standard.
- **Striker bars** ... standard on all Cat Landfill Compactors, prevents refuse from being carried over the rear wheels.
- **Caterpillar designed wheels** ... We test and build a Cat system. Engineers who work together with our power train, structures and manufacturing engineers design and manufacture our wheels in the same facility in which the machines are designed and built. This ensures the entire system is complemented by each component. If you alter components, you could compromise a system that was designed and tested for peak performance. If a wheel is produced that does not meet our design specifications and does not balance the load over our final drives, it could reduce the life of the bearing substantially and wear out other components creating unnecessary downtime. This also allows our standard axle guard system to work with the components for which it was designed.
- **Wheel and tip configurations** ... Three new wheel and tip configurations are available to meet your particular application:
 - 1) **Paddle tip** — High performance and less fuel burn with more traction and less weight.
 - 2) **Plus tip** — Traditional design for increased side slope stability and more mass for longer life.
 - 3) **Combination tip** — Both paddle and plus tips to give high performance with side slope stability.

MODEL	816F2		826K		836K	
Emission Standards	Tier 3 Equivalent ¹		Tier 4 Final ²		Tier 4 Final ²	
Gross Power	189 kW	253 hp	320 kW	430 hp	419 kW	562 hp
Operating Weight*	23 744 kg	52,364 lb	40 666 kg	89,653 lb	55 927 kg	123,319 lb
Engine Model	C9 ACERT		C15 ACERT		C18 ACERT	
Rated Engine RPM	2100		1800		1800	
No. Cylinders	6		6		6	
Displacement	8.8 L	537 in ³	15.2 L	928 in ³	18.1 L	1105 in ³
Speeds:						
Forward	2		2		2	
Reverse	2		2		2	
Turning Radius with Straight Blade						
Inside Wheels	3.5 m	11'6"	2.8 m	9'2"	3.6 m	11'11"
Outside Blade Corner	6.5 m	21'2"	7.23 m	23'9"	8.8 m	28'11"
Fuel Tank Refill Capacity	464 L	122.6 U.S. gal	782 L	206.6 U.S. gal	793 L	209 U.S. gal
DEF Tank Refill Capacity	—		32.8 L	9.0 U.S. gal	32.8 L	9.0 U.S. gal
WHEELS:	PLUS TIP		PLUS TIP		PLUS TIP	
Each Drum Width	1.02 m	3'4"	1.2 m	3'11"	1.4 m	4'7"
Diameters, over Tips	1.7 m	5'10"	1.97 m	6'6"	2125 mm	7'0"
Drum only	1.3 m	4'3"	1.61 m	5'3"	1.77 m	5'10"
Tips per Wheel	20		30		40	
Tip Height	158 mm	6.5"	178 mm	7"	178 mm	7"
Chopper Blades per Wheel	20		24		28	
Blade Height	152 mm	6"	158 mm	6"	158 mm	6"
Width of Two Pass Coverage	4.5 m	14'9"	4.78 m	15'8"	5.67 m	18'7"
GENERAL DIMENSIONS:						
Height (Overall)	3.8 m	12'8"	4.76 m	15'7"	4.85 m	15'11"
Height (Top of Cab)	3.4 m	11'3"	4.19 m	13'9"	4.3 m	14'1"
Wheel Base	3.35 m	11'0"	3.7 m	12'2"	4.55 m	14'11"
Overall Length with Dozer	7.85 m	25'7"	8.27 m	27'2"	10.18 m	33'5"
Width over Drums	3.33 m	10'11"	3.8 m	12'8"	4.18 m	14'1"
Ground Clearance	456 mm	1'5"	645 mm	2'1"	632 mm	2'1"
STRAIGHT BLADE:						
Width	3.65 m	12'0"	4.5 m	14'9"	5.19 m	17'0"
Height**	1.91 m	6'3"	1.91 m	6'3"	2.24 m	7'4"

*Operating Weight includes coolant, full hydraulics, full fuel tank, all heaviest options and 82 kg (180 lb) operator.

**Height (stripped top) — without ROPS cab, exhaust, seat back or other easily removed encumbrances.

¹ Meets Tier 3, Stage IIIA, Japan 2006 (Tier 3) equivalent emission standards.

² Meets Tier 4 Final, Stage IV and Japan 2014 (Tier 4 Final) emission standards.

816F2

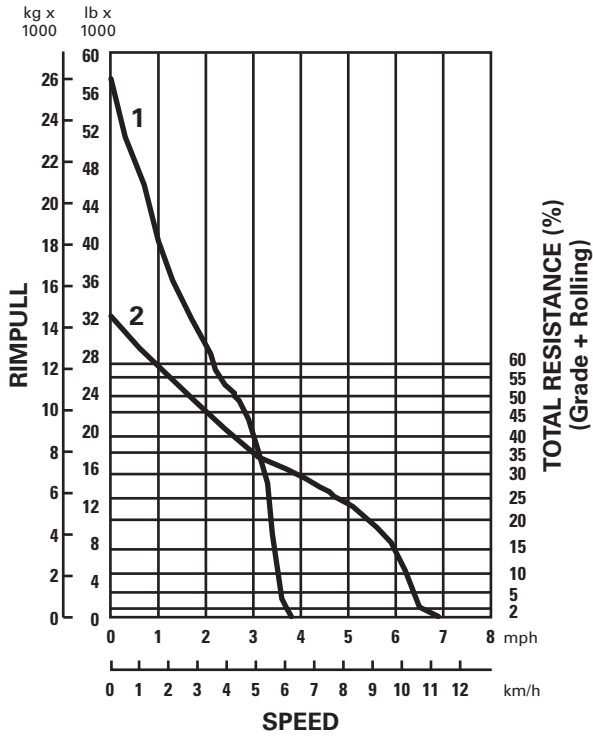

KEY
1 - 1st Gear
2 - 2nd Gear

826K

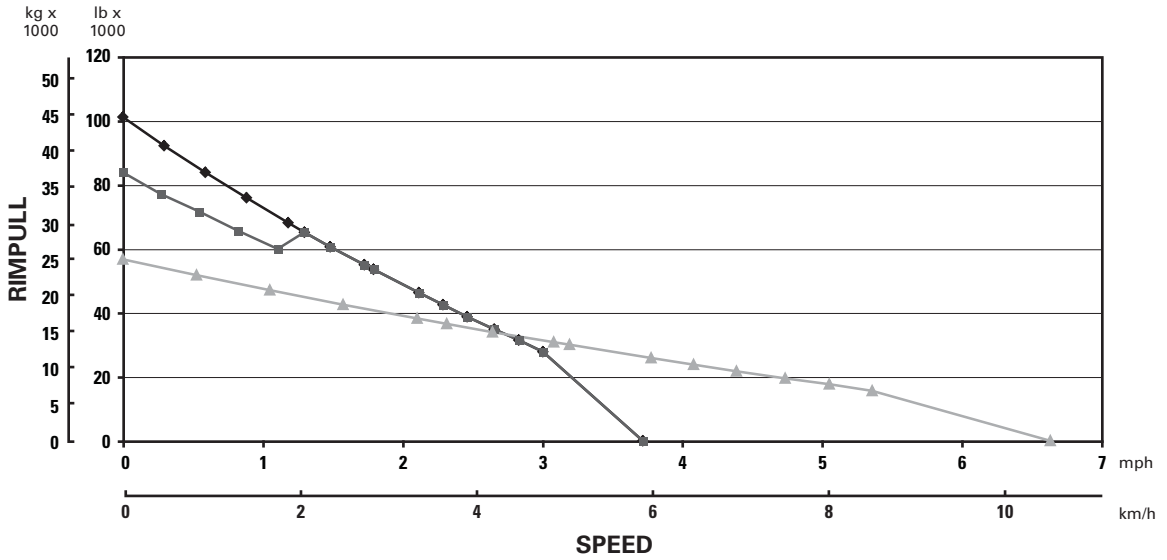

836K

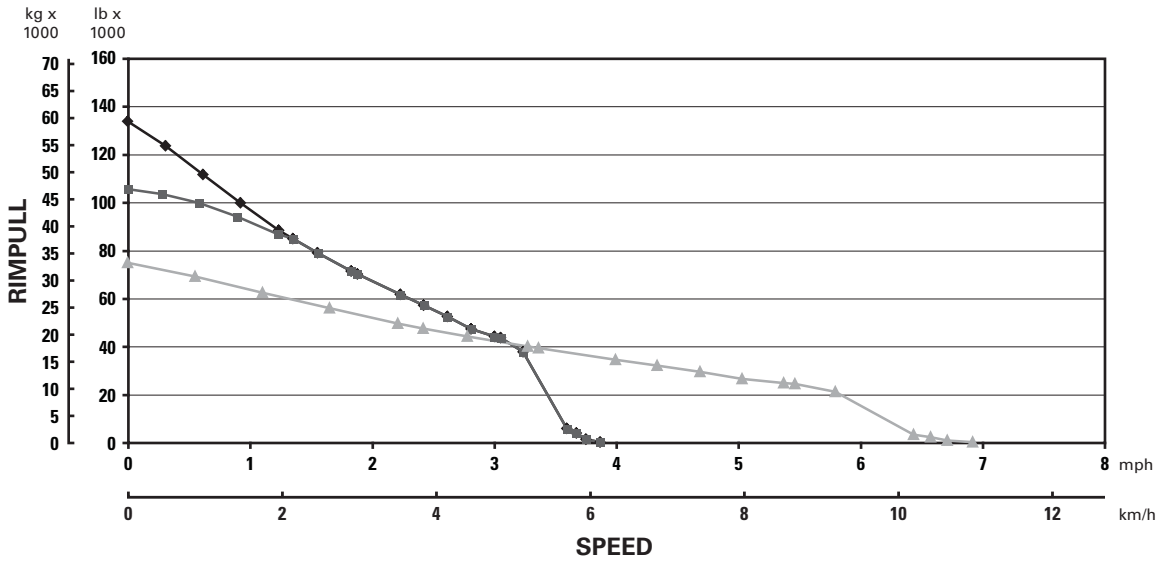

KEY
 ◆ 1F CD
 ■ 1F CD with PTS
 ▲ 2F CD

MODEL	816F2		826K		836K	
Type	Straight		Straight		Straight	
Capacity**						
Earth	2.9 m ³	3.79 yd³	3.68 m ³	4.81 yd³	5 m ³	6.66 yd³
Refuse	11 m ³	14.39 yd³	13 m ³	17 yd³	19.8 m ³	25.9 yd³
Weight, Dozer*	2107 kg	4645 lb	2517 kg	5549 lb	3400 kg	7650 lb
General Dimensions: (Tractor and Dozer)						
Width	3.65 m	12'0"	4.5 m	14'9"	5.19 m	17'0"
Blade Dimensions:						
Width, End Bits	3.65 m	12'0"	4.5 m	14'9"	5.19 m	17'0"
Height, Trash Rack	1914 mm	6'3"	1940 mm	6'4"	2222 mm	7'3"

*Total Bulldozer Arrangement.

**Blade capacities determined by SAE recommended practice J1265.

U-BLADE	816F2		826K		836K	
Blade:						
Capacity (Refuse)	9.74 m ³	12.74 yd³	17.5 m ³	22.9 yd³	9.74 m ³	13 yd³
Cutting Width	3.73 m	12'3"	4.39 m	14'5"	3.73 m	12'3"
Weight, Installed (without Hydraulics)	—	—	2574 kg	5675 lb	3839 kg	8465 lb

SEMI-U BLADE	816F2		826K		836K	
Blade:						
Capacity (Refuse)	8.95 m ³	11.71 yd³	16 m ³	20.9 yd³	22.4 m ³	29.3 yd³
Cutting Width	3.71 m	12'2"	4.52 m	14'10"	5.31 m	17'5"
Weight, Installed (without Hydraulics)	—	—	2731 kg	6021 lb	3744 kg	8256 lb

Features:

Cat Waste Handling Wheel Loaders are equipped with the features and protection required in a demanding waste handling environment. These Caterpillar designed and built machines feature the following advantages:

- **Exceptional productivity** with fast cycle times for maximum production day-in day-out whether dozing, loading, stacking, or load and carry.
- **Protected work environment** enhances operator comfort, convenience and productivity.
- **Modified front frames** — (Standard on the 980H WHA) provide large cutouts that allows debris to fall out rather than packing and also provide easy access if cleaning is necessary.
- **Standard front drive guard and axle seal guards** (except 980H) protect from wire, string, strapping and other debris from wrapping and causing damage.
- **Front light guards** protect the lights from debris falling over the bucket spill plate.
- **Hinged crankcase and power train guards** help protect the engine and power train. The hinged design provides easy access for cleaning. (Powered guards available on some models.)
- **Standard waste application cooling system.** The improved, trash-resistant, multi-row module (IMRM) radiator, hood and engine enclosures work as a system to keep the radiator and engine compartment free of debris.
- **Trash resistant IMRM radiator** has six fins per inch (25.4 mm) and in-line tubes that resist plugging by allowing debris to pass through the core.
- **Hinged radiator prescreener** (966H and 972H) eliminates debris larger than what the radiator core will pass.
- **Hinged grill** (966H and 972H) allows access to hydraulic oil cooler and air conditioning condenser, which swing out for easy cleaning.

Recommended Waste Handling Options

- **Powered crankcase and power train guards** raise and lower at the flip of a switch allowing fast, easy and frequent cleanings.
- **High lift arrangement** increases bucket hinge pin height offering increased stacking and stockpiling capability. A critical feature when incoming volumes exceed conveyor capacity or floor space.
- **Traction control system (TCS)** option for 938H/IT38H provides maximum traction in slippery conditions. TCS electronically senses and limits wheel slip at each wheel independently.
- **Limited-slip differential** limits tire slip on both front and rear axles. Increases traction and reduces tire wear and scuffing in wet or dry conditions. Provides an alternative to the No SPIN differential which is not recommended due to increased tire wear, turning interference and poor tracking on dry surfaces.
- **Tire options:**
 - L-5 bias hard rock lug
 - L-5 slick
 - RL-5K Goodyear radials
 - XMINE Michelin radials (varies by model)
 - Foam-filled
- **Hitch guards** help protect components in hitch area from damage.
- **Reversing radiator fan** is hydraulically driven and can be reversed by a switch in the operator station or automatically by timer. Reduces need for cooling system cleaning and improves cooling capability.
- **Other guarding and options** are available. Contact your Cat dealer for information.

Work Tools

- **Refuse bucket** has excellent dozing and stockpiling capability. Large spill plate helps protect the machine from debris falling over the top of the bucket. Available in pin-on or quick coupler configurations.
- **Pallet forks** are ideal for handling refuse destined for further recycling or stacking refuse in landfills for covering.

- **Multi-purpose bucket** has the capability to clamp and sort large objects, doze cover material or other light dozing chores.
- **Quick coupler** increases versatility by allowing a single machine to utilize a wide variety of work tools in a host of applications.

MODEL	926M WHA		930M WHA		938M WHA	
Emission Standards	Tier 4 Final***		Tier 4 Final***		Tier 4 Final***	
Flywheel Power	110 kW	148 hp	117 kW	157 hp	136 kW	182 hp
Rated Power	114 kW	153 hp	122 kW	166 hp	140 kW	190 hp
Engine Model	C7.1 ACERT		C7.1 ACERT		C7.1 ACERT	
Rated Engine RPM	1800		1800		1800	
Bore	105 mm	4.13"	105 mm	4.13"	105 mm	4.13"
Stroke	135 mm	5.31"	135 mm	5.31"	135 mm	5.31"
No. Cylinders	6		6		6	
Displacement	7.01 L	427 in³	7.01 L	427 in³	7.01 L	427 in³
Speeds Forward and Reverse	km/h	mph	km/h	mph	km/h	mph
1st	1.0-13.0	0.6-8.0	1.0-13.0	0.6-8.0	1.0-13.0	0.6-8.0
2nd	13.0	8.0	13.0	8.0	13.0	8.0
3rd	27.0	17.0	27.0	17.0	27.0	17.0
4th	40.0	25.0	40.0	25.0	40.0	25.0
Hydraulic Cycle Time*						
Rated Load in Bucket:	Seconds		Seconds		Seconds	
Raise	5.5		5.1		5.5	
Dump	1.5		1.5		1.5	
Lower (empty, float down)	2.6		2.7		2.7	
Total	9.6		9.3		9.7	
Tread Width**	1.93 m	6'3"	1.93 m	6'3"	2.08 m	6'10"
Width Over Tires**	2.54 m	8'4"	2.54 m	8'4"	2.69 m	8'10"
Ground Clearance**	397 mm	1'4"	397 mm	1'4"	386 mm	1'3"
Fuel Tank Capacity	195 L	51.5 U.S. gal	195 L	51.5 U.S. gal	195 L	51.5 U.S. gal
Hydraulic Tank Capacity	90 L	23.8 U.S. gal	90 L	23.8 U.S. gal	90 L	23.8 U.S. gal
Hinge Pin Height:						
Full Lift Std.	3907 mm	12'9"	3907 mm	12'9"	3969 mm	13'0"
High Lift	4400 mm	14'5"	4500 mm	14'9"	4550 mm	14'11"
Operating Weight up to:	18 800 kg	41,447 lb	19 000 kg	41,888 lb	20 200 kg	44,533 lb

*With standard lift arms.

**With standard tires.

***Meets Tier 4 Final, Stage IV and Japan 2014 (Tier 4 Final) emission standards.

NOTE: Dimensions listed are for a machine configured with Fusion work tool, counterweights, additional guarding, 80 kg (176 lb) operator, and Michelin 20.5 R25 (L-3) XHA2 tires.

MODEL	924K WHA		930K WHA		938K WHA	
Flywheel Power	105 kW	141 hp	119 kW	160 hp	140 kW	188 hp
Rated Power	101 kW	135 hp	115 kW	154 hp	136 kW	182 hp
Engine Model	C7.1 ACERT		C7.1 ACERT		C7.1 ACERT	
Rated Engine RPM	1800		1800		1800	
Bore	105 mm	4.13"	105 mm	4.13"	105 mm	4.13"
Stroke	135 mm	5.31"	135 mm	5.31"	135 mm	5.31"
No. Cylinders	6		6		6	
Displacement	7.0 L	428 in³	7.0 L	428 in³	7.0 L	428 in³
Speeds Forward and Reverse	km/h	mph	km/h	mph	km/h	mph
1st	1.0-13.0	0.6-8.0	1.0-13.0	0.6-8.0	1.0-13.0	0.6-8.0
2nd	13.0	8.0	13.0	8.0	13.0	8.0
3rd	27.0	17.0	27.0	17.0	27.0	17.0
4th	40.0	25.0	40.0	25.0	40.0	25.0
Hydraulic Cycle Time*	Seconds		Seconds		Seconds	
Rated Load in Bucket:						
Raise		5.4		5.1		5.5
Dump		1.5		1.5		1.5
Lower (empty, float down)		2.6		2.7		2.7
Total		9.5		9.3		9.7
Tread Width**	1930 mm	6'3"	1930 mm	6'3"	2065 mm	6'9"
Width Over Tires**	2540 mm	8'4"	2540 mm	8'4"	2675 mm	8'9"
Ground Clearance**	397 mm	1'3"	397 mm	1'3"	386 mm	1'3"
Fuel Tank Capacity	195 L	51.5 U.S. gal	195 L	51.5 U.S. gal	195 L	51.5 U.S. gal
Hydraulic Tank Capacity	90 L	23.8 U.S. gal	90 L	23.8 U.S. gal	90 L	23.8 U.S. gal
Hinge Pin Height:						
Full Lift Std.	3853 mm	12'7"	3907 mm	12'9"	3969 mm	13'0"
High Lift	—		4500 mm	14'9"	4550 mm	14'11"
Operating Weight up to:						
Standard Lift	18 800 kg	41,447 lb	19 000 kg	41,888 lb	20 200 kg	44,533 lb

*With standard lift arms.

**With standard tires.

NOTE: Dimensions listed are for a machine configured with general purpose pin on buckets, bolt-on cutting edges, optional counterweights, 80 kg (176 lb) operator, and Michelin 20.5 R25 (L-3) XHA2 tires.

MODEL	950M WHA		962M WHA		966M WHA	
Maximum Engine: Net	171 kW	230 hp	186 kW	250 hp	206 kW	276 hp
Gross	187 kW	250 hp	202 kW	271 hp	232 kW	311 hp
Engine Model	C7.1 ACERT		C7.1 ACERT		C9.3 ACERT	
Maximum Net Power Engine RPM	2100		2100		1700	
Bore	105 mm	4.1"	105 mm	4.1"	115 mm	4.53"
Stroke	135 mm	5.3"	135 mm	5.3"	149 mm	5.87"
No. Cylinders	6		6		6	
Displacement	7.01 L	427.8 in³	7.01 L	427.8 in³	9.3 L	568 in³
Speeds Forward:	km/h	mph	km/h	mph	km/h	mph
1st	6.9	4.3	6.9	4.3	6.5	4.0
2nd	12.0	7.5	12.0	7.5	13.0	8.1
3rd	19.3	12.0	19.3	12.0	23.5	14.6
4th	25.7	16.0	25.7	16.0	39.5	24.5
5th	39.5	24.5	39.5	24.5	—	—
Speeds Reverse:	km/h	mph	km/h	mph	km/h	mph
1st	6.9	4.3	6.9	4.3	7.1	4.4
2nd	12.0	7.5	12.0	7.5	14.4	8.9
3rd	25.7	16.0	25.7	16.0	25.9	16.1
4th	—	—	—	—	39.0	24.2
Hydraulic Cycle Time, Rated Load in Bucket:	Seconds		Seconds		Seconds	
Raise	5.1		5.2		6.1	
Dump	1.5		1.5		1.4	
Lower (Empty, Float Down)	2.3		2.7		2.8	
Total	8.9		9.4		10.3	
Tread Width	2140 mm	7'0"	2140 mm	7'0"	2230 mm	7'4"
Width Over Tires	2790 mm	9'2"	2790 mm	9'2"	2991 mm	9'10"
Ground Clearance	385 mm	1'3"	385 mm	1'3"	476 mm	1'7"
Fuel Tank Capacity	135 L	35.7 U.S. gal	135 L	35.7 U.S. gal	313 L	82.7 U.S. gal
DEF Tank Capacity	11 L	2.9 U.S. gal	11 L	2.9 U.S. gal	16.8 L	4.4 U.S. gal
Hydraulic Tank Capacity	125 L	33 U.S. gal	125 L	33 U.S. gal	125 L	33.0 U.S. gal

NOTE: Net Engine Power is provided according to SAE J1349 and ISO 9249. Gross Engine Power is provided according to SAE J1995. Machines may only be available in certain regions. Contact your local Cat dealer for product availability.

NOTE: These machines can be configured with engines to meet various emission standards. Contact your local Cat dealer for product availability.

MODEL	972M WHA		980M WHA	
Maximum Engine: Net	223 kW	299 hp	288 kW	386 hp
Gross	251 kW	337 hp	317 kW	425 hp
Engine Model	C9.3 ACERT		C13 ACERT	
Maximum Net Power Engine RPM	1700		1700	
Bore	115 mm	4.53"	130 mm	5.1"
Stroke	149 mm	5.87"	157 mm	6.2"
No. Cylinders	6		6	
Displacement	9.3 L	568 in³	12.5 L	762.8 in³
Speeds Forward:	km/h	mph	km/h	mph
1st	6.7	4.2	6.9	4.3
2nd	13.1	8.1	13.3	8.3
3rd	23.2	14.4	23.5	14.6
4th	39.5	24.5	39.5	24.5
5th	—		—	
Speeds Reverse:	km/h	mph	km/h	mph
1st	7.6	4.7	7.8	4.8
2nd	15.0	8.9	15.2	9.4
3rd	26.5	16.5	26.9	16.7
4th	39.5	24.5	39.5	24.5
Hydraulic Cycle Time, Rated Load in Bucket:	Seconds		Seconds	
Raise	6.1		5.3	
Dump	1.5		1.7	
Lower (Empty, Float Down)	3.1		3.1	
Total	10.7		10.1	
Tread Width	2230 mm	7'4"	2440 mm	8'0"
Width Over Tires	2991 mm	9'10"	3265 mm	10'9"
Ground Clearance	476 mm	1'7"	453 mm	1'6"
Fuel Tank Capacity	313 L	82.7 U.S. gal	441 L	116 U.S. gal
DEF Tank Capacity	16.8 L	4.4 U.S. gal	21 L	5.5 U.S. gal
Hydraulic Tank Capacity	125 L	33.0 U.S. gal	180 L	48 U.S. gal

NOTE: Net Engine Power is provided according to SAE J1349 and ISO 9249. Gross Engine Power is provided according to SAE J1995. Machines may only be available in certain regions. Contact your local Cat dealer for product availability.

NOTE: These machines can be configured with engines to meet various emission standards. Contact your local Cat dealer for product availability.

MODEL	950K WHA		962K WHA	
Peak Net Power	157 kW	210 hp	165 kW	222 hp
Peak Gross Power	173 kW	232 hp	181 kW	243 hp
Engine Model	C7.1 ACERT		C7.1 ACERT	
Peak Net Power Engine RPM	1900		1900	
Bore	105 mm	4.1"	105 mm	4.1"
Stroke	135 mm	5.3"	135 mm	5.3"
No. Cylinders	6		6	
Displacement	7.01 L	427.8 in³	7.01 L	427.8 in³
Speeds Forward	km/h	mph	km/h	mph
1st	6.9	4.3	6.9	4.3
2nd	12.9	8.0	12.9	8.0
3rd	22.7	14.1	22.7	14.1
4th	37.9	23.6	37.9	23.6
Speeds Reverse				
1st	7.5	4.7	7.5	4.7
2nd	14.1	8.8	14.1	8.8
3rd	24.8	15.4	24.8	15.4
4th	39.8	24.7	39.8	24.7
Hydraulic Cycle Time				
Rated Load in Bucket:	Seconds		Seconds	
Raise	5.9		5.9	
Dump	1.8		1.8	
Lower (empty, float down)	2.5		2.5	
Total	10.0		10.0	
Tread Width	2.14 m	7'0"	2.14 m	7'0"
Width Over Tires	2.79 m	9'2"	2.79 m	9'2"
Ground Clearance	397 mm	1'3"	397 mm	1'3"
Fuel Tank Capacity	314 L	83 U.S. gal	314 L	83 U.S. gal
Hydraulic Tank Capacity	137 L	36 U.S. gal	137 L	36 U.S. gal
Hydraulic System Capacity (includes tank)	189 L	50 U.S. gal	189 L	50 U.S. gal

NOTE: These machines meet Tier 4 Interim/Stage IIIB equivalent emission standards. Contact your local Cat dealer for product availability.
NOTE: Net Engine Power is provided according to SAE J1349 and ISO 9249. Gross Engine Power is provided according to SAE J1995.

MODEL	966K WHA		972K WHA		980K WHA	
Peak Net Power	199 kW	267 hp	215 kW	289 hp	274 kW	369 hp
Peak Gross Power	222 kW	296 hp	237 kW	318 hp	303 kW	407 hp
Engine Model	C9.3 ACERT		C9.3 ACERT		C13 ACERT	
Peak Net Power Engine RPM	1800		1800		1600	
Bore	115 mm	4.5"	115 mm	4.5"	130 mm	5.1"
Stroke	149 mm	5.9"	149 mm	5.9"	157 mm	6.2"
No. Cylinders	6		6		6	
Displacement	9.3 L	568 in³	9.3 L	568 in³	12.5 L	762.8 in³
Speeds Forward	km/h	mph	km/h	mph	km/h	mph
1st	6.7	4.2	7.0	4.4	6.9	4.3
2nd	12.6	7.8	12.5	7.8	12.2	7.6
3rd	22.4	13.9	21.4	13.3	21.3	13.2
4th	37.4	23.2	36.9	22.9	37.2	23.1
Speeds Reverse						
1st	7.8	4.9	8.0	5.0	7.8	4.8
2nd	13.7	8.5	14.3	8.9	13.8	8.6
3rd	23.5	14.6	24.5	15.2	24.2	15.1
4th	38.5	23.9	42.2	26.2	42.4	26.3
Hydraulic Cycle Time						
Rated Load in Bucket:	Seconds		Seconds		Seconds	
Raise	5.9		5.9		6.4	
Dump	1.5		2.0		1.7	
Lower (Empty, Float Down)	2.4		2.4		3.3	
Total	9.8		10.3		11.4	
Tread Width	2.23 m	7'4"	2.23 m	7'4"	2.44 m	8'0"
Width Over Tires	3.01 m	9'11"	3.02 m	9'11"	3307 mm	10'9"
Ground Clearance	475 mm	1'6"	475 mm	1'6"	460 mm	1'6"
Fuel Tank Capacity	381 L	101 U.S. gal	381 L	101 U.S. gal	447 L	118.1 U.S. gal
Hydraulic Tank Capacity	137 L	36 U.S. gal	137 L	36 U.S. gal	156 L	41 U.S. gal
Hydraulic System Capacity (includes tank)	200 L	52 U.S. gal	200 L	52 U.S. gal	271 L	72 U.S. gal

NOTE: These machines meet Tier 4 Interim/Stage IIIB equivalent emission standards. Contact your local Cat dealer for product availability.

NOTE: Net Engine Power is provided according to SAE J1349 and ISO 9249. Gross Engine Power is provided according to SAE J1995.

MODEL	950H WHA		962H WHA	
Emission Standards	Tier 3 Equivalent***		Tier 3 Equivalent***	
Peak Net Power	147 kW	197 hp	156 kW	209 hp
Peak Gross Power	162 kW	217 hp	172 kW	231 hp
Engine Model	C7 ACERT		C7 ACERT	
Peak Net Power Engine RPM	1800		1800	
Bore	110 mm	4.3"	110 mm	4.3"
Stroke	127 mm	5"	127 mm	5"
No. Cylinders	6		6	
Displacement	7.2 L	439 in³	7.2 L	439 in³
Speeds Forward	km/h	mph	km/h	mph
1st	6.9	4.3	7.0	4.4
2nd	12.7	7.9	13.0	8.1
3rd	22.3	13.9	22.6	14.0
4th	37.0	23.0	38.0	23.6
Speeds Reverse				
1st	7.6	4.7	7.6	4.7
2nd	13.9	8.6	13.9	8.6
3rd	24.5	15.2	24.5	15.2
4th	40.5	24.9	40.0	24.9
Hydraulic Cycle Time*				
Rated Load in Bucket:	Seconds		Seconds	
Raise	6.2		6.2	
Dump	2.0		2.0	
Lower (empty, float down)	2.5		2.5	
Total	10.7		10.7	
Tread Width**	2.14 m	7'0"	2.14 m	7'0"
Width Over Tires**	2.79 m	9'2"	2.79 m	9'2"
Ground Clearance**	412 mm	16"	412 mm	16"
Fuel Tank Capacity	264 L	70 U.S. gal	264 L	70 U.S. gal
Hydraulic Tank Capacity	110 L	29 U.S. gal	110 L	29 U.S. gal
Hinge Pin Height:				
Full Lift Std.	3.99 m	13'1"	3.99 m	13'1"
High Lift with L-5 tires	4.54 m	14'10"	—	
Operating weight up to:	19 213 kg	42,365 lb	20 269 kg	44,693 lb

*With standard lift arms.

**With standard tires.

***Meets Tier 3, Stage IIIA, Japan 2006 (Tier 3) equivalent emission standards.

NOTE: Not available in all regions. Contact your local Cat dealer for product availability.

NOTE: Net Engine Power is provided according to SAE J1349 and ISO 9249. Gross Engine Power is provided according to SAE J1995.

MODEL	966H WHA		972H WHA		980H WHA	
Emission Standards	Tier 3 Equivalent***		Tier 3 Equivalent***		Tier 3 Equivalent***	
Peak Net Power	195 kW	262 hp	214 kW	287 hp	237 kW	318 hp
Peak Gross Power	211 kW	283 hp	232 kW	311 hp	261 kW	351 hp
Engine Model	C11 ACERT		C13 ACERT		C15 ACERT	
Peak Net Power Engine RPM	1800		1800		1800	
Bore	130 mm	5.1"	130 mm	5.1"	137 mm	5.4"
Stroke	140 mm	5.5"	157 mm	6.2"	171 mm	6.75"
No. Cylinders	6		6		6	
Displacement	11.1 L	677 in ³	12.5 L	763 in ³	15.2 L	928 in ³
Speeds Forward	km/h	mph	km/h	mph	km/h	mph
1st	6.7	4.2	7.2	4.5	6.6	4.1
2nd	12.6	7.8	12.6	7.8	11.8	7.3
3rd	22.1	13.7	21.4	13.3	20.7	12.9
4th	37.4	23.2	36.9	22.9	36.3	22.6
Speeds Reverse						
1st	7.4	4.6	8.2	5.1	7.6	4.7
2nd	13.7	8.6	14.2	8.8	13.5	8.4
3rd	23.4	15.1	24.3	15.1	23.7	14.7
4th	37.4	23.2	38.8	24.0	41.5	25.8
Hydraulic Cycle Time*						
Rated Load in Bucket:	Seconds		Seconds		Seconds	
Raise	5.9		5.9		6.0	
Dump	1.6		2.1		2.0	
Lower (empty, float down)	2.4		2.4		3.4	
Total	9.9		10.4		11.4	
Tread Width**	2.23 m	7'4"	2.23 m	7'4"	2.44 m	8'0"
Width Over Tires**	3.00 m	9'10"	3.00 m	9'10"	3.18 m	10'5"
Ground Clearance**	434 mm	17"	434 mm	17"	430 mm	16.9"
Fuel Tank Capacity	380 L	100 U.S. gal	380 L	100 U.S. gal	453 L	120 U.S. gal
Hydraulic Tank Capacity	110 L	29 U.S. gal	110 L	29 U.S. gal	125 L	33 U.S. gal
Hinge Pin Height:						
Full Lift Std.	4.23 m	13'10"	4.87 m	14'8"	4.51 m	14'9"
High Lift with L-5 tires	4.79 m	15'8"	4.81 m	15'9"	4.75 m	15'7"
Operating weight up to:	24 237 kg	53,443 lb	26 051 kg	57,442 lb	31 599 kg	69,676 lb

*With standard lift arms.

**With standard tires.

***Meets Tier 3, Stage IIIA, Japan 2006 (Tier 3) equivalent emission standards.

NOTE: Not available in all regions. Contact your local Cat dealer for product availability.

NOTE: Net Engine Power is provided according to SAE J1349 and ISO 9249. Gross Engine Power is provided according to SAE J1995.

WORK TOOLS

As described in the opening statements of this section, the waste stream can consist of many different types of materials sometimes all blended together. For that reason, work tools become a very important part of moving,

sorting, and dozing in waste applications. (Continue to consider the thought process of; “what is the application and material(s) you will work with — then, what tool(s) will accomplish your objectives, and finally, what machine(s) will utilize that tool to perform in that application?”)

Wheel Loader Work Tools

MODEL	924K, 926M	930K, 930M	938K, 938M	950M, 962M, 950K, 962K, 950H, 962H	966M, 972M, 966K, 972K, 966H, 972H	980M, 980K, 980H
Bucket — Load & Carry	x	x	x	x	x	x
Bucket — Dozing	x	x	x	x	x	x
Bucket — Multi-Purpose	x	x	x	x	x	x
Bucket — Waste Handling*	x	x	x	x	x	x

*The “Waste Handling” bucket is a current bucket that is being phased out and replaced by the Load & Carry and Dozing buckets. All are in the current price lists.

NOTE: Other attachments available upon request. Contact your Cat dealer.

NOTE: Learn more about available work tools @ WorkTool Central: <https://dealer.cat.com/products/wtc>.

Excavator Work Tools

MODEL	308E CR	315D L, 316E L	318E	319D L, 319D LN	M313D, M315D	M316D, M318D, M322D	M318D MH, M322D MH	320E L, 320E LRR, 321D CR, 323D	320C MH	M322D MH	324D, 324E
Grapple — Contractors’	x	x	x	x	x	x	x	x			x
Grapple — Demolition and Sorting		x	x	x	x	x		x			x
Grapple — Orange Peel							x		x	x	
Grapple — Trash		x	x	x	x	x		x			x

NOTE: Normal Waste Applications utilize the Trash, Sorting, and Orange Peel Grapples. Depending on the application, these work tools might be advisable.

NOTE: Learn more about available work tools in the *Hydromechanical Work Tools* chapter of the *Performance Handbook*.

NOTE: Learn more about available work tools @ WorkTool Central: <https://dealer.cat.com/products/wtc>.

(Chart continued on next page)

Excavator Work Tools (cont'd)

MODEL	M325D MH, 320C MH	329D, 329E	336D, 336E	MH3049	345D, 349D, 349E	345C MH	MH3059	365C L	374D	385C	390D
Grapple — Contractors'		x	x		x			x	x	x	x
Grapple — Demolition and Sorting		x	x		x						
Grapple — Orange Peel	x			x		x	x				
Grapple — Trash		x	x		x						

NOTE: Normal Waste Applications utilize the Trash, Sorting, and Orange Peel Grapples. Depending on the application, these work tools might be advisable.

NOTE: Learn more about available work tools in the *Hydromechanical Work Tools* chapter of the *Performance Handbook*.

NOTE: Learn more about available work tools @ WorkTool Central: <https://dealer.cat.com/products/wtc>.

There are a variety of work tools for small-medium wheel loaders that have couplers. It is important to check the tasks that the wheel loader will perform and equip as needed. The 924-980 wheel loaders have three waste specific designed 'pin on' buckets to choose from.

- **Load & Carry Bucket** — An overall use bucket that is open and deep throated to gather and retain large loads. This bucket provides the ability to push, stockpile, load, and tamp no matter what type of loading is required.
- **Doze Bucket** — The height of this bucket provides more of a push platform to move heavy loads on the floor into waiting haul vehicles. Its main strengths are for pushing, stockpiling, and loading below grade vehicles.
- **Tamp and Clamp Bucket** — Designed with a longer snout and "optional" top clamps, this bucket is best for sorting, loading, and tamping haul vehicles with hard to handle materials. It has slightly less capacity than the load & carry and push buckets.

There are a variety of waste work tools for excavators and wheeled excavators. For Tracked and Wheeled Excavators you need to ask its primary use. Loading and Tamping, Sorting, Combination, Other Support?

- **Trash Grapple** — Designed to load and tamp large loads of material into haul vehicles. They can perform some material separation, but its main strength would be to load and tamp.

- **Sorting Grapple** — This grapple is designed to sort, separate, and load material. Equipped with a rotator, its main strength lies in the ability to separate material quickly, swing/rotate, and load haul vehicles, conveyors, and hoppers efficiently.
- **Orange Peel Grapple** — Also designed to sort, separate, and load material, its main strength is in a slightly larger load capability than the sorting grab. It also has the capability to rotate.
- **Contractor's Grapple** — Designed like the Waste Grapple, it is slightly smaller with a two over three tine configuration instead of four over five. It is heavier in construction and designed for materials heavier than MSW.

There is a wide variety of work tools for Excavators (wheeled and tracked) that can be used in waste applications; the above are "waste handling" tools designed for the application.

Support Work Tools

Brooms, pallet forks, bale clamps, blades, lifting arms, are just a few of the 'coupler attached' work tools that are used within the waste industry. A thorough assessment of primary and support roles of machine needs to be performed.

As stated in the chart, please contact your Dealer/Waste Representative or *Cat.com* websites for more information.

WHEEL DOZERS SOIL COMPACTORS

CONTENTS

WHEEL DOZERS

Features	22-1
Specifications	22-2
Travel Speeds	22-4
Rimpull	22-4
Machine Selection	22-6
Counterweights and Ballast	22-6
Tire Selection & Maintenance	22-7
Bulldozer Specifications	22-8
Work Tools Specifications	22-9

SOIL COMPACTORS

Features	22-11
Specifications	22-12
Rimpull	22-13
Compaction Fundamentals	22-14
Compactor Types and Zones of Application	22-15
Estimating Production (Example Problem)	22-16
Production Table	22-17
Bulldozer Specifications	22-17
Ground Contact Pressures	22-18

WHEEL DOZERS

Features:

- **Reliable Cat® power train:** four-stroke-cycle diesel with adjustment-free fuel system ... full power shift with single lever on-the-go shifting.
- **Articulated frame steering** with hinge point midway between front and rear axles ... short turning radius, long wheelbase ... rear and front wheels track at all times.
- **Machine balance** ... equal weight distribution on axles when blading.
- **All dozer functions**, including tip and tilt, hydraulically controlled from operator's seat.
- **STIC™ (Steering Transmission Integrated Control)** Steering is now offered on all Wheel Dozers, except the 814.

Throughout this document, references to Tier 4 Interim/Stage IIIB/Japan 2011 (Tier 4 Interim) include U.S. EPA Tier 4 Interim, EU Stage IIIB, and Japan 2011 (Tier 4 Interim) emission standards. References to Tier 4 Final/Stage IV/Japan 2014 (Tier 4 Final) include U.S. EPA Tier 4 Final, EU Stage IV, and Japan 2014 (Tier 4 Final) emission standards.

Throughout this document, references to Tier 1/Stage I include U.S. EPA Tier 1 and EU Stage I equivalent emission standards. References to Tier 2/Stage II/Japan 2001 (Tier 2) equivalent include U.S. EPA Tier 2, EU Stage II, and Japan 2001 (Tier 2) equivalent emission standards. References to Tier 3/Stage IIIA/Japan 2006 (Tier 3) equivalent include U.S. EPA Tier 3, EU Stage IIIA, and Japan 2006 (Tier 3) equivalent emission standards.

MODEL	814F2		824K	
Tier 4 Final/Stage IV/Japan 2014 (Tier 4 Final):			Prefix 234	
Flywheel Power	—			
Net	—		302 kW	405 hp
Max.	—		324 kW	435 hp
Tier 3/Stage IIIA/Japan 2006 (Tier 3) Equivalent:			Prefix RWB	
Flywheel Power	Prefix BXG			
Net	173 kW	232 hp	302 kW	405 hp
Max.	189 kW	253 hp	324 kW	435 hp
Operating Weight*	21 713 kg	47,877 lb	34 004 kg	74,966 lb
Emission Standards	Tier 3/Stage IIIA/ Japan 2006 (Tier 3) Equivalent		Tier 4 Final/Stage IV/ Japan 2014 (Tier 4 Final) Tier 3/Stage IIIA/ Japan 2006 (Tier 3) Equivalent	
Engine Model	C9 ACERT™		C15 ACERT	
Rated Engine RPM	2100		1800	
No. Cylinders	6		6	
Displacement	8.8 L	537 in³	15.2 L	928 in³
Speeds:				
Forward	4		4	
Reverse	4		4	
Top Speed Forward	30.9 km/h	19.2 mph	34.7 km/h	21.6 mph
Turning Circle with Blade	7.17 m	23'6"	6.0 m	19'8"
Standard Tire Size	23.5-25, 12 PR (L-2)		29.5R25 (VSDL)	
Fuel Tank Refill Capacity	446 L	118 U.S. gal	782 L	206.6 U.S. gal
Diesel Exhaust Fluid Tank Refill Capacity [required for Tier 4 Final/Stage IV/ Japan 2014 (Tier 4 Final) machines]	—		32 L	8.5 U.S. gal
GENERAL DIMENSIONS:				
Height (to top of ROPS)	3.3 m	10'8"	4.1 m	13'5"
Height (stripped top)**	2.4 m	7'9"	3.3 m	10'5"
Wheel Base	3.35 m	11'0"	3.7 m	12'2"
Overall Length with Dozer Blade	6.9 m	22'8"	8.4 m	27'8"
Width (over standard tires)	2.8 m	9'2"	3.37 m	11'0"
Ground Clearance	366 mm	14.4"	441.4 mm	17.4"
	Straight Bulldozer		Straight Bulldozer	
Width	3.6 m	11'8"	4.5 m	14'8"
Height	1.1 m	3'6"	1.23 m	4'0"
Capacity	2.73 LCM	3.6 LCY	5.0 LCM	6.5 LCY
Ground Clearance Below Skid Shoe	748 mm	2'6"	1.06 m	3'6"
Depth of Cut	528 mm	20.8"	448 mm	17.6"
Tilt Adjustment	795 mm	2'6"	1.17 m	3'8"
Tip Adjustment	15°		22.4°	
Lift Speed	0.4 m/sec	1.3 ft/sec	0.46 m/sec	1.46 ft/sec

*Operating Weight includes straight dozer, lubricants, coolant, ROPS cab, full fuel tank and operator. 75% CaCl₂ in all tires adds the following weight to each model: 814F2 — 2342 kg (5164 lb), 824K — 4296 kg (9472 lb).

**Height (stripped top) — without ROPS, exhaust, seat back or easily removed encumbrances.

MODEL	834K		844K		854K	
Tier 4 Final/Stage IV/ Japan 2014 (Tier 4 Final):						
Flywheel Power	Prefix TWY		Prefix MBE		Prefix H8M	
Net	370 kW	496 hp	521 kW	699 hp	607 kW	814 hp
Max.	419 kW	562 hp	571 kW	766 hp	671 kW	900 hp
Tier 3/Stage IIIA/Japan 2006 (Tier 3) Equivalent:						
Flywheel Power	Prefix LWY		—		—	
Net	370 kW	496 hp	—		—	
Max.	419 kW	562 hp	—		—	
Tier 2/Stage II/Japan 2001 (Tier 2) Equivalent:						
Flywheel Power	Prefix LWY		Prefix KLS		Prefix H9K	
Net	370 kW	496 hp	521 kW	699 hp	607 kW	814 hp
Max.	419 kW	562 hp	571 kW	766 hp	676 kW	907 hp
Operating Weight*	47 750 kg	105,271 lb	74 883 kg	165,089 lb	98 100 kg	216,273 lb
Emission Standards	Tier 4 Final/Stage IV/ Japan 2014 (Tier 4 Final)¹		Tier 4 Final/Stage IV/ Japan 2014 (Tier 4 Final)²		Tier 4 Final/Stage IV/ Japan 2014 (Tier 4 Final)²	
Engine Model	C18 ACERT		C27 ACERT		C32 ACERT	
Rated Engine RPM	1800		1800		1750	
No. Cylinders	6		12		12	
Displacement	18.1 L	1105 in³	27.0 L	1650 in³	32.1 L	1959 in³
Speeds:						
Forward	4		3		3	
Reverse	3		3		3	
Top Speed Forward	35.4 km/h	22 mph	21 km/h	13 mph	21.2 km/h	13.2 mph
Turning Circle with Blade	17.6 m	57'9"	21.73 m	71'4"	23.4 m	76'9"
Standard Tire Size	35/65-R33, 24 PR (L-4)		45/65-R39, PR (L-4)		45/65-R45 (L-4)	
Fuel Tank Refill Capacity	793 L	209 U.S. gal	1016 L	268 U.S. gal	1562 L	413 U.S. gal
Diesel Exhaust Fluid Tank Refill Capacity	32 L	8.5 U.S. gal	—		—	
GENERAL DIMENSIONS:						
Height (to top of ROPS)	4.18 m	13'7"	5.240 m	17'2"	5590 mm	18'3"
Height (stripped top)**	3.15 m	10'4"	3.8 m	12'6"	5234 mm	17'2"
Wheel Base	4.55 m	14'11"	4.6 m	15'1"	5890 mm	19'3"
Overall Length with Dozer Blade	10.42 m	34'2"	11.12 m	36'6"	13 405 mm	44'0"
Width (over standard tires)	3.47 m	11'5"	4.37 m	14'4"	3556 mm	11'8"
Ground Clearance	531 mm	21"	431 mm	1'5"	691 mm	27"
	Straight Bulldozer		Semi-U Dozer		Semi-U Dozer	
Width	5.07 m	16'8"	5.278 m	17'4"	6321 mm	20'8"
Height	1.54 m	5'0"	1.877 m	6'2"	5590 mm	18'3"
Capacity	7.87 LCM***	10.3 LCY***	16.1 m ³	21.1 yd³	25.4 m ³	33.1 yd³
Ground Clearance Below						
Skid Shoe	1324 mm	4'4"	1372 mm	4'6"	691 mm	27"
Depth of Cut	557 mm	21.9"	466 mm	18"	398 mm	1'3"
Tilt Adjustment	1.27 m	4'2"	830 mm	2'9"	1165 mm	3'8"
Tip Adjustment	21°		13°		15°	
Lift Speed	0.81 m/sec	2.66 ft/sec	0.353 m/sec	1.2 ft/sec	0.310 m/sec	1.05 ft/sec

*Operating Weight of 844K and 854K includes Semi-U, coolant, ROPS cab, full fuel tank and operator.

Operating Weight of 834K includes straight dozer, lubricants, coolant, ROPS cab, full fuel tank and operator.

**Height (stripped top) — without ROPS, exhaust, seat back or easily removed encumbrances.

***Capacity of 834K U-Blade is 11.1 LCM (**14.5 LCY**).

¹Products available to meet Tier 2/Stage II/Japan 2001 (Tier 2) equivalent, Tier 3/Stage IIIA/Japan 2006 (Tier 3) equivalent, or Tier 4 Final/Stage IV/Japan 2014 (Tier 4 Final) emission standards.

²Products available to meet Tier 2/Stage II/Japan 2001 (Tier 2) equivalent, or Tier 4 Final/Stage IV/Japan 2014 (Tier 4 Final) emission standards.

MODEL	814F2		824K		834K*		844K*		854K*	
FORWARD GEAR	km/h	mph	km/h	mph	km/h	mph	km/h	mph	km/h	mph
1	5.7	3.6	6.2	3.9	6.8	4.2	7.0	4.4	6.8	4.2
2	10.2	6.4	11.1	6.9	11.6	7.2	12.2	7.6	12.1	7.5
3	17.9	11.2	19.6	12.2	20.3	12.6	21.0	13.0	20.9	13.0
4	31.0	19.3	34.8	21.6	35.4	22.0	—	—	—	—
REVERSE GEAR										
1	6.5	4.1	7.1	4.4	6.8	4.2	7.7	4.6	7.5	4.7
2	11.6	7.3	12.6	7.8	12.2	7.6	13.4	8.4	13.3	8.3
3	20.4	12.7	22.4	13.9	21.4	13.3	23.0	14.3	23.0	14.3
4	34.9	21.8	39.7	24.7	—	—	—	—	—	—

*2% rolling resistance.

814F2

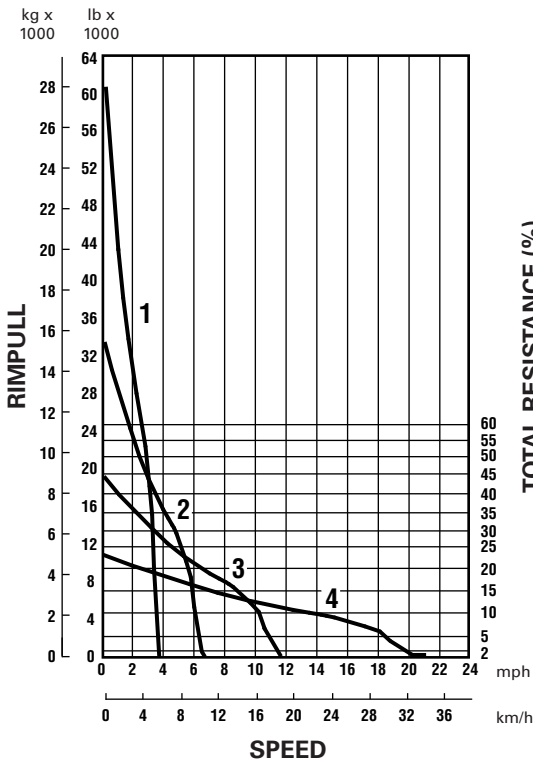

824K

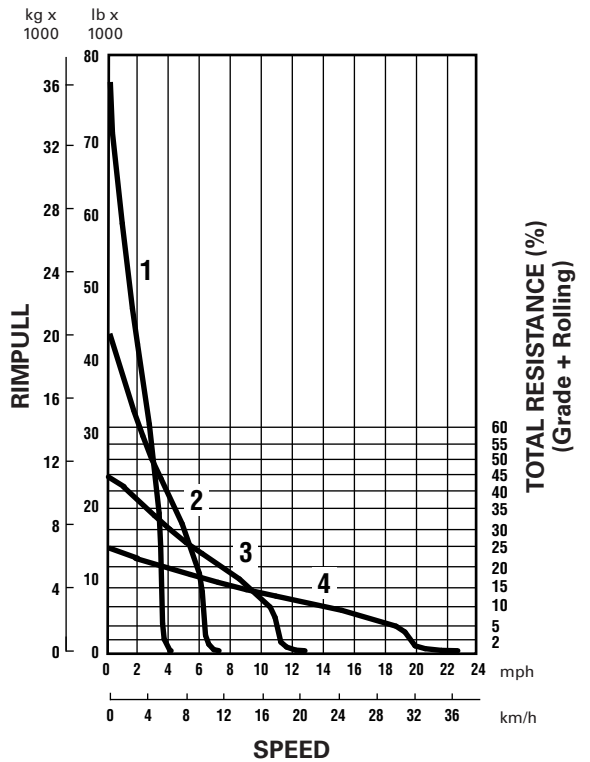

KEY
 1 - 1st Gear
 2 - 2nd Gear
 3 - 3rd Gear
 4 - 4th Gear

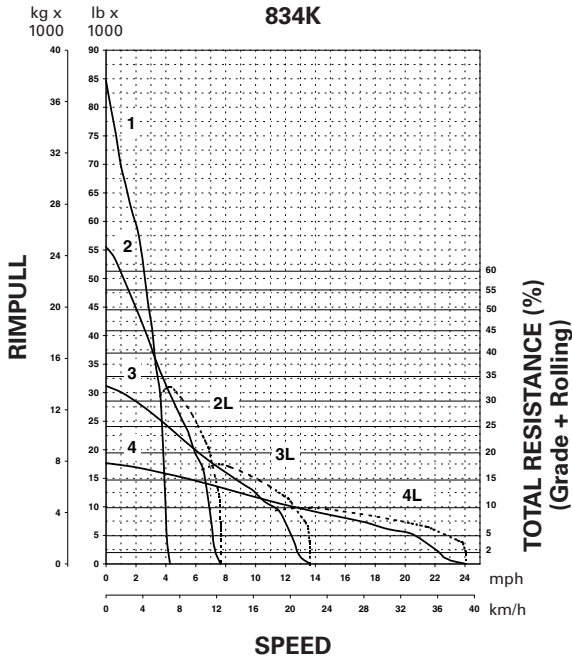

KEY

- 1 - 1st Gear
- 2 - 2nd Gear
- 3 - 3rd Gear
- 4 - 4th Gear

--- Direct Drive
 - - - Torque Converter

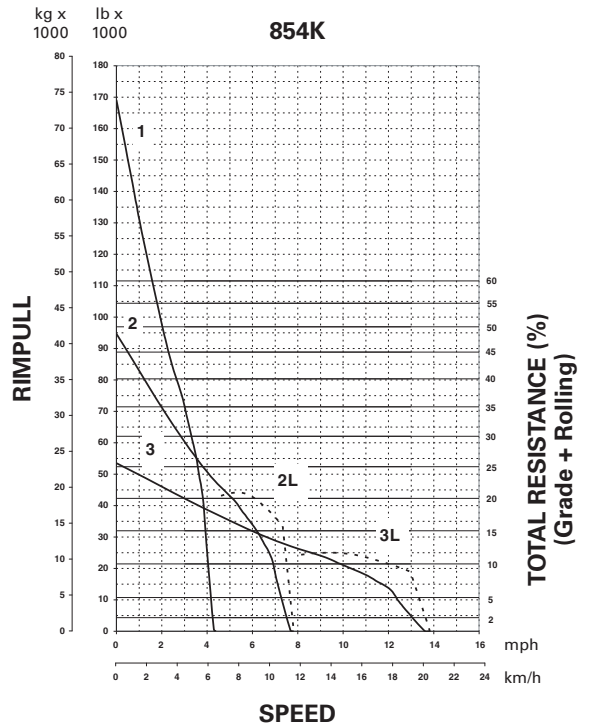
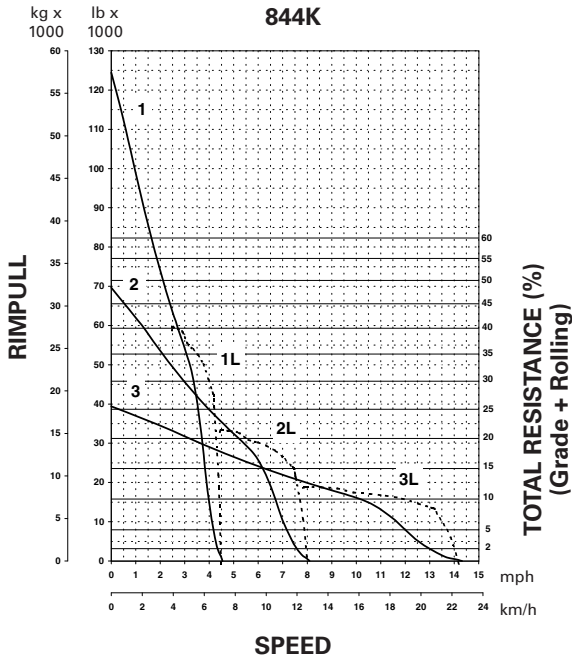

CONSIDERATIONS IN MACHINE SELECTION

The following factors should be considered when comparing wheels vs. tracks:

Traction

You can figure coefficient of traction, depending on underfoot conditions, from the Table Section in this book.

Wheels — up to 0.65 (in quarry pit with good floor)

Track — up to 0.90 (in soils permitting grouser penetration)

Usable Rimpull = Machine Weight × Coefficient of Traction

Speed

Wheels — travel speeds up to three times higher than track.

Maneuverability

Articulated steering and good visibility give wheel tractors high maneuverability.

Cost

See Owning and Operating Costs section. Tire vs. undercarriage costs can often be the deciding factor in selecting wheels or tracks.

Compaction

Ground Pressure:

Wheels — from 241 kPa (35 psi) to 310 kPa (45 psi)

Tracks — from 82 kPa (12 psi) to 97 kPa (14 psi)

Application

Utility ... mobility, maneuverability and good speed suit wheel tractors for yard and stockpile work and for clean-up around shovels. Lower maintenance costs may be realized in certain soils that can be highly abrasive to track-type undercarriages.

Coal pile ... recommend wheel tractors in this application when following conditions are present:

- Long push distances
- Need for good material spread
- High degree of compaction desired

Production Dozing ... a wheel tractor should be considered in the following conditions:

- Long push distances
- Loose soils, little or no rock
- Level or downhill work
- Good underfoot conditions

Pushloading Scrapers ... a wheel tractor should be considered in the following conditions:

- Thin scraper cut
- Good underfoot conditions — no rock
- Higher push speeds

Chip and Coal Scoops ... a wheel dozer scoop should be considered in the following conditions:

- Long push distances
- Light, well processed materials such as coal or wood chips
- High degree of compaction desired
- Low to modest grades

COUNTERWEIGHTS AND BALLAST

For each specific application, there is a correct machine weight for proper balancing of traction, flotation, mobility and response.

- Low machine weight may increase tire slipping and wear, but improves flotation, mobility and machine response.
- High machine weight increases traction, but decreases mobility and response.

The machine weight is optimum for the operating conditions when wheel slipping barely occurs in the gear being used. Weight distribution under operating conditions should then be approximately equal between the wheels to balance power to each axle.

Application

Lower machine weight is usually required for applications such as fill spreading, stockpiling, road maintenance, towing compactors, and shovel cleanup. These are generally performed in either first or second gear. However, usage of second gear may involve a tradeoff of increased GET wear on the blade.

Higher machine weight is usually required for applications such as heavy dozing and push-loading, which are generally performed in first gear.

TIRE SELECTION & MAINTENANCE

Requirements of traction, flotation and tire life are met by a choice of tire size, tread design and inflation pressure.

Tire Width

For good conditions with little rolling resistance on surfaces where flotation is no problem, a narrower tire may be most economical. It may also be considered in muddy conditions in which the mud can be penetrated to reach firm earth underneath.

Where flotation problems and increased rolling resistance are encountered, wider tires are recommended. The greater contact area and shallower penetration increases flotation.

Tire Size

Larger optional tires will also improve flotation in soft conditions. With larger diameter, rimpull will be reduced which may be desirable to help control wheel spin.

Rock — Deep Tread (L-4) provides 50% more tread depth, thicker undertread and sidewall with increased tire life when compared to the L-3 tire. Recommended in rock conditions where sharp fragments cause high tire wear or sudden failures.

Rock — Extra Deep Tread (L-5) provides 150% more tread depth when compared to the L-3 tire. Intended for severe rock conditions with extreme penetration hazards.

Inflation Pressure

In average operating conditions the recommended inflation pressure prevents excessive deflection and minimizes tire rollover on side slopes.

Over-inflation

Reduces amount of tread contact with ground and provides less flotation. Over-inflation causes center of tread to wear faster and increases the chance of cuts and impact breaks.

Under-inflation

Can cause permanent tire damage in the form of flex breaks, radial cracks, and tread or ply separation. On jobs where wrinkling and bead rollover *are not* apparent, inflation pressure may be reduced to a minimum of:

<i>Bias Ply</i>	—	170 kPa (25 psi) on 35/65-33
		170 kPa (25 psi) on 29.5-25
		170 kPa (25 psi) on 26.5-25
		170 kPa (25 psi) on 23.5-25
<i>Radial</i>	—	310 kPa (45 psi) on 35/65-R33
		310 kPa (45 psi) on 29.5-R25
		205 kPa (30 psi) on 26.5-R25
		240 kPa (35 psi) on 23.5-R25

Reduced pressure will:

- Increase flotation and traction in sand.
- Improve envelopment characteristics to reduce sudden death failure on rock jobs.
- Provide better tread wear by reducing contact pressure between tire and ground.

Consult your tire manufacturer before changing tire pressures.

MODEL	814F2		824K		824K	
Type	Straight		Straight		SU-Blade	
Capacity**	2.66 m ³	3.5 yd ³	5.0 m ³	6.6 yd ³	6.88 m ³	9.0 yd ³
Weight, Dozer*	3740 kg	8245 lb	5136 kg	11,323 lb	—	
General Dimensions (Tractor & Dozer)						
Length	6.9 m	22'6"	8.2 m	26'9"	—	
Width	3.6 m	11'8"	4.51 m	14'8"	4.44 m	14'7"
Blade:						
Width (including std. end bits)	3.6 m	11'8"	4.51 m	14'8"	4.44 m	14'7"
Height	1100 mm	3'6"	1230 mm	4'0"	1584 mm	5'2"
Max. Digging Depth	528 mm	20.8"	448 mm	17.6"	542 mm	21"
Ground Clearance @ Full Lift Under Skid Plate	718 mm	2'4"	1057 mm	3'5"	996 mm	3'3"
Tilt Adjust. from Horizontal	795 mm	2'6"	1167 mm	3'8"	1166 mm	3'10"
Total Tip Adjustment	15°		22.4°		—	

MODEL	824K		824K		834K	
Type	U-Blade		Extreme Service U-Blade		Straight	
Capacity**	7.7 m ³	10.0 yd ³	7.7 m ³	10.0 yd ³	7.9 m ³	10.33 yd ³
Weight, Dozer*	—		—		47 206 kg	104,069 lb
General Dimensions (Tractor & Dozer)						
Length	—		—		9.93 m	32'7"
Width	4.35 m	14'3"	4.35 m	14'3"	5.07 m	16'7"
Blade:						
Width (including std. end bits)	4.35 m	14'3"	4.35 m	14'3"	5.07 m	16'7"
Height	1350 mm	4'4"	1350 mm	4'4"	1537 mm	5'0"
Max. Digging Depth	461 mm	18.1"	461 mm	18.1"	557 mm	21.9"
Ground Clearance @ Full Lift Under Skid Plate	1051 mm	3'5"	1051 mm	3'5"	1324 mm	4'4"
Tilt Adjust. from Horizontal	1132 mm	3'7"	1132 mm	3'7"	1270 mm	4'2"
Total Tip Adjustment	—		—		20.5°	

MODEL	834K		834K		844K		854K	
Type	U-Blade		SU-Blade		Semi-U		Semi-U	
Capacity**	11.13 m ³	14.56 yd ³	10.13 m ³	13.25 yd ³	15.9 m ³	20.7 yd ³	25.4 m ³	33.1 yd ³
Weight, Dozer*	48 564 kg	107,064 lb	8052 kg	17,751 lb	15 670 kg	34,520 lb	21 910 kg	48,270 lb
General Dimensions (Tractor & Dozer)								
Length	10.47 m	34'4"	10.47 m	34'4"	10.94 m	35'9"	13.405 m	44'0"
Width	5.15 m	16'11"	4.69 m	15'5"	5.42 m	17'8"	6.321 m	20'7"
Blade:								
Width (including std. end bits)	5.15 m	16'11"	4.69 m	15'5"	5.42 m	17'8"	6.321 m	20'7"
Height	1537 mm	5'0"	1855 mm	6'1"	1834 mm	5'9"	2179 mm	7'1"
Max. Digging Depth	527 mm	20.7"	507 mm	20.0"	466 mm	18.3"	398 mm	15.7"
Ground Clearance @ Full Lift Under Skid Plate	1338 mm	4'4"	1352 mm	4'5"	1372 mm	4'6"	1540 mm	5'0.04"
Tilt Adjust. from Horizontal	1270 mm	4'2"	1270 mm	4'2"	830 mm	2'8.7"	1165 mm	3'8"
Total Tip Adjustment	22°		22°		13°		15°	

*Total Bulldozer Arrangement.

**Blade capacities determined by SAE J1265.

COAL U-BLADE	814F2		824K		834K	
Model: Replaces "S" Blade	Coal U-Blade		Coal U-Blade		Coal U-Blade	
Blade:						
Capacity	11 m ³	14 yd ³	16.2 m ³	21 yd ³	22.2 m ³	29 yd ³
Length (Cutting Width)	4318 mm	14'2"	4798 mm	15'8"	5680 mm	18'7"
Height, wing section (tapered down)	1473 mm	4'10"	1745 mm	5'7"	1960 mm	6'5"
Wing Angle	25°		30°		30°	
Weight, Installed (Without Hydraulics)	1950 kg	4300 lb	3193 kg	7040 lb	5020 kg	11,300 lb

	844K		854K	
Model: Replaces "S" Blade	Coal U-Blade		Coal U-Blade	
Blade:				
Capacity	30.7 m ³	40.2 yd ³	44.7 m ³	58.2 yd ³
Length (Cutting Width)	5846 mm	19'2"	7200 mm	23'7"
Height, wing section (tapered down)	2024 mm	6'8"	2500 mm	8'2"
Wing Angle	30°		30°	
Weight, Installed (Without Hydraulics)	6237 kg	13,830 lb	10 333 kg	22,780 lb

WOODCHIP U-BLADE	824K		834K	
Model: Replaces "S" Blade	Woodchip U-Blade		Woodchip U-Blade	
Blade:				
Capacity	24 m ³	31 yd ³	30.1 m ³	40 yd ³
Length (Cutting Width)	4775 mm	15'8"	5700 mm	18'8"
Height, wing section	2261 mm	7'5"	2350 mm	7'8"
Wing Angle	30°		30°	
Weight	3515 kg	7750 lb	5155 kg	11,600 lb

COAL SCOOP WITH TILT	814F2		824K		834K	
Model: Scoop:	Coal Scoop with Tilt		Coal Scoop with Tilt		Coal Scoop with Tilt	
Lift and Carrying Capacity	11.5 m ³	15 yd ³	13.4 m ³	17.5 yd ³	22.9 m ³	30 yd ³
Dozing Capacity	19.1 m ³	25 yd ³	26.8 m ³	35 yd ³	44.2 m ³	58 yd ³
Width	3734 mm	12'3"	4058 mm	13'4"	4851 mm	15'11"
Height	1626 mm	5'4"	1839 mm	6'1"	2339 mm	7'8"
Weight	5216 kg	11,500 lb	6763 kg	14,913 lb	9711 kg	21,409 lb

CHIP SCOOP WITH TILT	814F2		824K		834K	
Model: Scoop:	Chip Scoop with Tilt		Chip Scoop with Tilt		Chip Scoop with Tilt	
Lift and Carrying Capacity	15.3 m ³	20 yd ³	20.6 m ³	27 yd ³	26.7 m ³	35 yd ³
Dozing Capacity	30.6 m ³	40 yd ³	41.3 m ³	54 yd ³	53.5 m ³	70 yd ³
Width	3734 mm	12'3"	4039 mm	13'3"	4851 mm	15'11"
Height	2286 mm	7'6"	2489 mm	8'2"	2649 mm	8'8"
Weight	5390 kg	11,880 lb	11 420 kg	19,125 lb	9804 kg	21,614 lb

SOIL COMPACTORS

CONTENTS

Features	22-11
Specifications	22-12
Rimpull	22-13
Compaction Fundamentals	22-14
Compactor Types and Zones of Application	22-15
Estimating Production (Example Problem)	22-16
Production Table	22-17
Bulldozer Specifications	22-17
Ground Contact Pressures	22-18

Features:

- **Dozing, filling and compacting versatility.**
- **High speed operation** with responsive Cat diesel engine, single-lever planetary power shift transmission, and all-wheel drive.
- **Articulated frame** makes maneuvering quick and easy. Long wheel base for stability.
- **Wheels with tamping foot design and chevron pattern** give traction, penetration and compaction needed for high production. Foot pattern reversed on trailing drums to prevent overprinting lead drums.
- **Rear drums track front** for double compactive effort. Drum spacing covers mid-axle strip on return pass.
- **Rear axle oscillation** keeps all drums on ground for traction and stability.
- **Cleaner bars** keep drums free of carry over earth regardless of rolling direction. Adjustable, replaceable.
- **Optional fill spreading dozer** has single lever control for raise, lower, hold and float. (Blade tilt optional.)
- The 825K now offers **STIC (Steering Transmission Integrated Control) Steering** as a standard feature.

MODEL	815F2		825K	
Tier 4 Final/Stage IV/Japan 2014 (Tier 4 Final):				
Flywheel Power	—		Prefix 233	
Net	—		302 kW	405 hp
Max.	—		324 kW	435 hp
Tier 3/Stage IIIA/Japan 2006 (Tier 3) Equivalent:				
Flywheel Power	Prefix BYN		Prefix SEE	
Net	173 kW	232 hp	302 kW	405 hp
Max.	189 kW	253 hp	324 kW	435 hp
Operating Weight*	20 755 kg	45,765 lb	35 528 kg	78,326 lb
Emission Standards	Tier 3/Stage IIIA/ Japan 2006 (Tier 3) Equivalent		Tier 4 Final/Stage IV/ Japan 2014 (Tier 4 Final) Tier 3/Stage IIIA/ Japan 2006 (Tier 3) Equivalent	
Engine Model	C9 ACERT		C15 ACERT	
Rated Engine RPM	2100		1800	
No. Cylinders	6		6	
Displacement	8.8 L	537 in³	15.2 L	928 in³
Speeds:				
Forward	3		3	
Reverse	3		3	
Turning Radius — outside Corner of Blade	6.45 m	21'3"	7.3 m	23'9"
Fuel Tank Refill Capacity	446 L	118 U.S. gal	782 L	206.6 U.S. gal
Diesel Exhaust Fluid Tank Refill Capacity [required for Tier 4 Final/Stage IV/ Japan 2014 (Tier 4 Final) machines]	—		32 L	8.5 U.S. gal
TAMPING FOOT WHEELS:				
Each Drum Width	991 mm	3'3"	1125 mm	3'8"
Diameters, over Feet	1.42 m	4'8"	1.68 m	5'5"
over Drum	1.03 m	3'5"	1.29 m	4'3"
Feet per Wheel	60		65	
Feet per Row	12		13	
Rows of Feet	5		5	
Foot Length	191 mm	7.5"	188 mm	7.4"
End Area per Foot	134 cm ²	20.8 in²	192 cm ²	29.75 in²
Width of Two Pass Coverage	4.2 m	13'9"	5.3 m	17'4"
GENERAL DIMENSIONS:				
Height (to top of ROPS)	3.34 m	11'0"	4.05 m	13'4"
Height (stripped top)**	2.39 m	7'10"	3.2 m	10'5"
Wheel Base	3.35 m	11'0"	3.7 m	12'2"
Overall Length with Dozer Blade	6.80 m	23'6"	8.56 m	28'1"
Width over Drums	3.24 m	10'8"	3.65 m	12'0"
Ground Clearance	390 mm	15.4"	492 mm	19.4"
STRAIGHT BULLDOZER:				
Width over End Bits	3.76 m	12'4"	4.62 m	15'1"
Height with Cutting Edge	860 mm	2'10"	1030 mm	3'4"

*Operating Weight includes coolant, lubricants, bulldozer, hydraulics, ROPS canopy, full fuel tank and operator.

**Height (stripped top) — without ROPS, exhaust, seat back or other easily removed encumbrances.

815F2

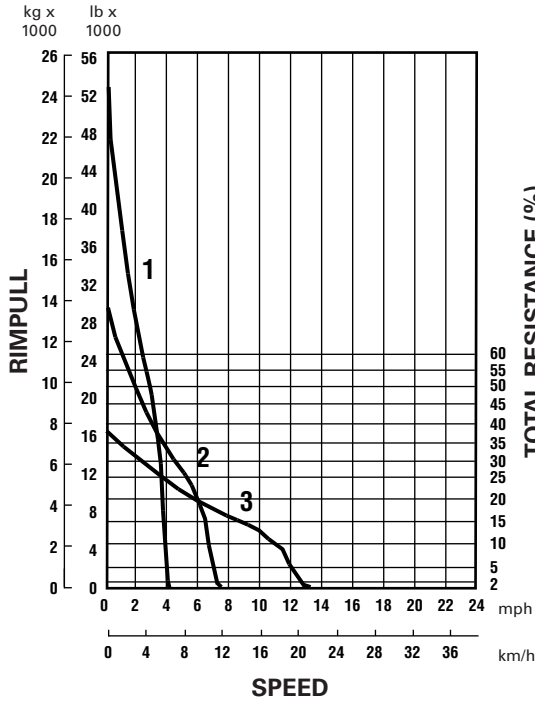

825K

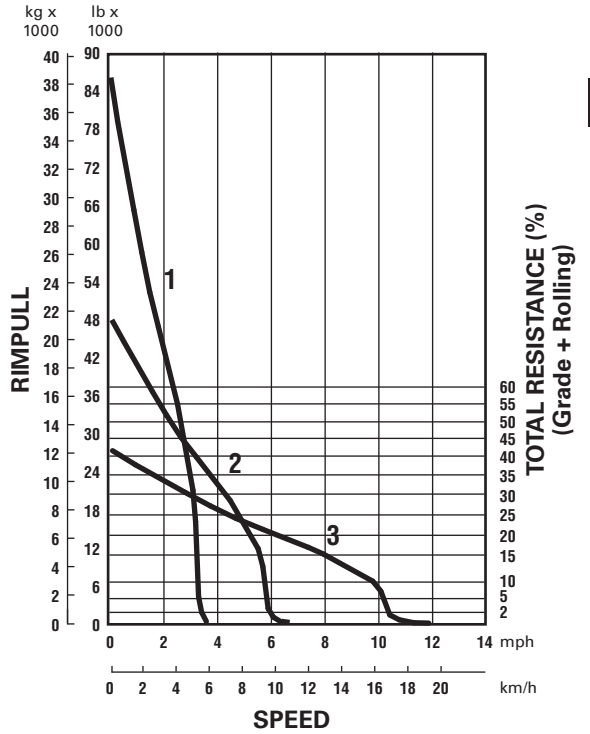

KEY
 1 - 1st Gear
 2 - 2nd Gear
 3 - 3rd Gear

COMPACTION FUNDAMENTALS

The following discussion applies to soil compaction only.

Definition

Compaction is the process of physically densifying or packing the soil ... resulting in increased weight per unit volume. It is generally accepted that the strength of a soil can be increased by densification. Three important factors affect compaction.

- Material gradation
- Moisture content
- Compactive effort

Material Gradation — refers to the distribution (% by weight) of the different particle sizes within a given soil sample. A sample is *well-graded* if it contains a good, even distribution of particle sizes. A sample composed of predominantly one size particle, is said to be *poorly-graded*. In terms of compaction, a well-graded soil will compact more easily than one that is poorly-graded. In well-graded material the smaller particles tend to fill the empty spaces between the larger particles, leaving fewer voids after compaction.

MATERIAL GRADATION

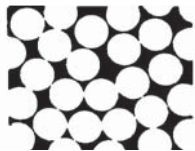

Poorly-graded

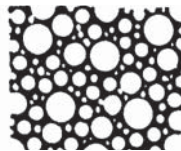

Well-graded

Moisture Content — or the amount of water present in a soil, is very important to compaction. Water lubricates soil particles thus helping them slide into the most dense position. Water also creates clay particle bonding, giving cohesive materials their sticky qualities.

OPTIMUM MOISTURE

Heavy clay	17.5%
Silty clay	15.0%
Sandy clay	13.0%
Sand	10.0%
Gravel, sand, clay mix (pit run)	7.0%

Experience has shown that it is very difficult, if not impossible, to achieve proper compaction in materials that are too dry or too wet. Soil experts have determined that in practically every soil there is an amount of water, called optimum moisture content, at which it is possible to obtain maximum density with a given amount of compactive effort. The curve below shows this relationship between dry density and moisture content. It is called a compaction curve, moisture-density curve or Proctor curve.

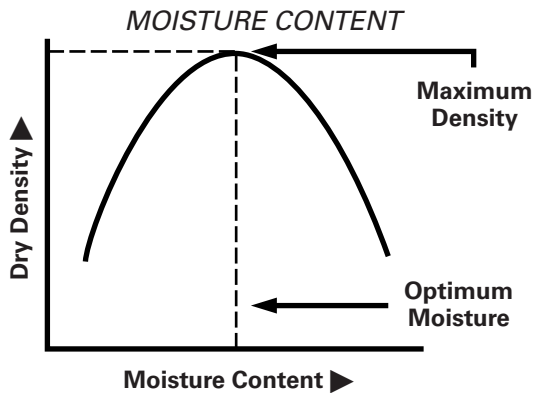

Compactive Effort — refers to the method employed by a compactor to impart energy into the soil to achieve compaction. Compactors are designed to use one or a combination of the following types of compactive effort.

- Static weight (or pressure)
- Kneading action (or manipulation)
- Impact (or sharp blow)
- Vibration (or shaking)

COMPACTOR TYPES

Compaction equipment can be grouped generally into the following classifications:

- sheepsfoot
- vibratory
- pneumatic
- high speed tamping foot
- chopper wheels (see Landfill Compactor section)

Combinations of these types are also available, such as a vibrating smooth steel drum.

For ease of comparison, the compactors have been placed on the Zones of Application Chart shown below. This chart contains a range of material moistures from 100% clay to 100% sand, plus a rock zone. Each type has been positioned in what is considered to be its most effective and economical zone of application. However, it is not uncommon to find them working out of their zones. Exact positioning of the zones can vary with differing material conditions.

RANGES OF SOIL TYPES FOR SOIL COMPACTION EQUIPMENT

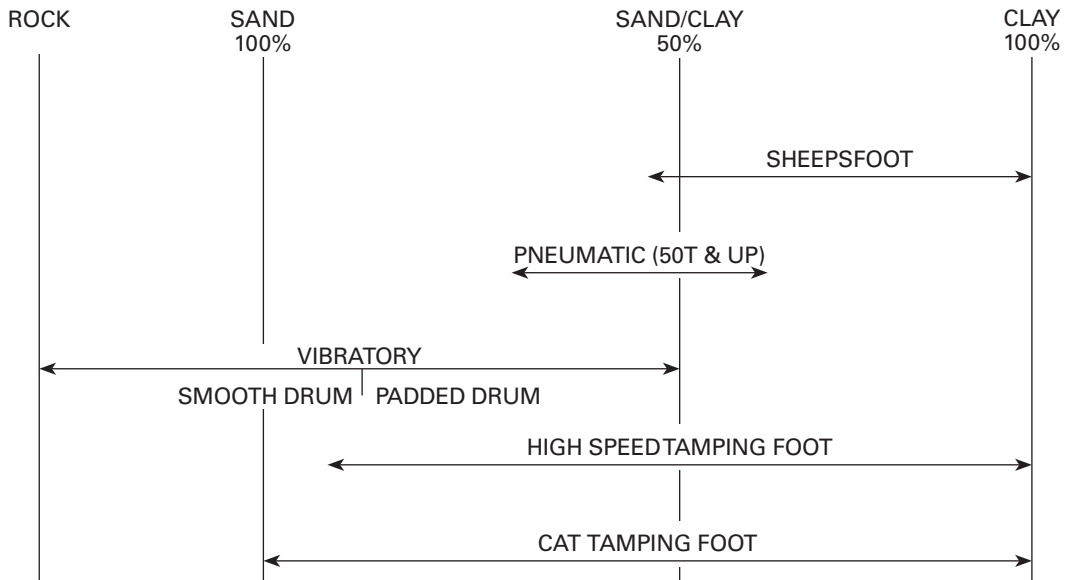

COMPACTOR PRODUCTION

Compactor production is expressed in compacted cubic meters (Cm³) or compacted cubic yards (CCY) per hour. Material in its natural or bank state is measured in bank cubic meters or yards (Bm³ or BCY). When it is removed or placed in a fill, it is measured in loose cubic meters or yards (Lm³ or LCY).

When the loose material is worked into a compacted state, the relationship of *compacted material to bank material* is shown as the shrinkage factor (SF).

$$SF = \frac{\text{Compacted cubic meters (Cm}^3\text{)}}{\text{Bank cubic meters (Bm}^3\text{)}}$$

$$SF = \frac{\text{Compacted cubic yards (CCY)}}{\text{Bank cubic yards (BCY)}}$$

The construction industry has developed the following formula for use in estimating compactor production. This formula gives the material volume a given machine can compact in a 60-minute hour.

Metric Method

$$\text{Cm}^3 = \frac{W \times S \times L}{P}$$

W = Compacted width per pass, in meters. (For Cat Compactors it is recommended that W = Twice the width of one wheel.)

S = Average speed, in kilometers per hour.

L = Compacted thickness of lift, in millimeters.

P = Number of machine passes to achieve compaction (**can only be determined by testing the compacted material density on-the-job**).

English Method

$$\text{CCY/hr} = \frac{W \times S \times L \times 16.3}{P}$$

W = Compacted width per pass, in feet. (For Cat Compactors it is recommended that W = Twice the width of one wheel.)

S = Average speed, in miles per hour.

L = Compacted thickness of lift, in inches.

16.3 = Conversion constant, equals 5280 feet ÷ 12 inches ÷ 27 cubic feet

P = Number of machine passes to achieve compaction (**can only be determined by testing the compacted material density on-the-job**).

Example problem (Metric)

Determine production for an 815F2 operating under the following conditions:

$$P = 5, S = 10 \text{ km/h}, L = 100 \text{ mm}$$

Refer to 815F2 in the production table on the next page. Read down the first column until reaching section for 5 passes. Within this section in the second column, find the speed closest to 10 km/h. Read across this line to the 100 mm compacted lift. Read the production figure given.

Answer: 377 Cm³/h. (Since the machine's speed of 10 km/h is slightly faster than the 9.5 of the table, production may be interpolated slightly higher — say 395 Cm³/h.)

Example problem (English)

Determine production for an 825K operating under the following conditions:

$$P = 4, S = 8 \text{ mph}, L = 6 \text{ inches}$$

Refer to the production estimating table on the next page. This table contains estimates for the 815F2 and 825K Compactors using various speeds, lift thicknesses and number of passes. These figures were calculated using the formula discussed on this page. The figures represent 100% efficiency. W = Twice the width of one wheel.

In the 825K portion of this table, read down the first column until reaching the section for four passes. Within this section in the second column, find the line for 8 mph. Read across this line to the lift thickness column for 6 inches. Read the production figure given.

Answer: 1444 CCY/hr.



PRODUCTION TABLE

MODEL AND MACHINE PASSES*	AVERAGE SPEED		COMPACTED LIFT THICKNESS								
			100 mm	4 in	150 mm	6 in	200 mm	8 in	250 mm	10 in	
	km/h	mph	m ³ /h	yd ³ /hr	m ³ /h	yd ³ /hr	m ³ /h	yd ³ /hr	m ³ /h	yd ³ /hr	
815F2	3	6.5	4	419	548	628	822	837	1095	—	
		9.5	6	628	822	942	1232	1256	1643	—	
		13.0	8	837	1095	1256	1643	1675	2191	—	
	4	6.5	4	314	411	471	616	628	822	—	
		9.5	6	471	616	706	924	942	1232	—	
		13.0	8	628	822	942	1232	1256	1643	—	
	5	6.5	4	251	329	377	493	502	657	—	
		9.5	6	377	493	565	739	754	986	—	
		13.0	8	502	657	754	986	1005	1314	—	
	6	6.5	4	286	274	314	411	419	548	—	
		9.5	6	314	411	471	616	628	822	—	
		13.0	8	419	548	628	822	837	1095	—	
825K	3	6.5	4	488	642	731	962	975	1283	1219	1604
		9.5	6	713	962	1069	1444	1425	1925	1781	2406
		13.0	8	975	1283	1463	1925	1950	2566	2438	3208
	4	6.5	4	366	481	534	722	731	962	914	1203
		9.5	6	534	722	802	1083	1069	1444	1336	1804
		13.0	8	731	962	1097	1444	1463	1925	1828	2406
	5	6.5	4	293	385	439	577	585	770	731	962
		9.5	6	428	577	641	866	855	1155	1069	1444
		13.0	8	585	770	878	1155	1170	1540	1463	1925
	6	6.5	4	244	321	366	481	488	642	609	802
		9.5	6	356	481	534	722	713	962	891	1203
		13.0	8	488	642	731	962	975	1283	1219	1604

*The number of machine passes required is dependent on soil type, moisture content, desired compaction and machine weight.

MODEL	815F2		825K	
Type	Fill Spreading		Fill Spreading	
Capacity**				
Earth	2.16 m ³	2.82 yd ³	3.79 m ³	4.95 yd ³
Refuse	—	—	—	—
Weight, Dozer*	1460 kg	3220 lb	2831 kg	6241 lb
General Dimensions: (Tractor & Dozer)				
Length	6.82 m	22'5"	8.24 m	27'5"
Width	3.76 m	12'4"	4.6 m	15'1"
Blade Dimensions:				
Width, End Bits	3.76 m	12'4"	4.6 m	15'1"
Height, Moldboard	860 mm	2'10"	1.03 m	3'4"
Height, Trash Rack	—	—	—	—
Max. Digging Depth	215 mm	8.5"	312 mm	12.3"
Ground Clearance @ Full Lift	814 mm	2'8"	932 mm	3'0.7"
Tilt Adjust. from Horizontal	328 mm	12.9"	797 mm	31.4"

*Total Bulldozer Arrangement.

**Blade capacities determined by SAE recommended practice J1265.

815F2 and 825K

Ground Contact Pressure/Soil Compactors

815F2 Tip	Weight Front Axle 9376 kg (20,674 lb) Ground Contact Pressure		Weight Rear Axle 11 460 kg (25,269 lb) Ground Contact Pressure		Contact Area Four Wheels	
	kPa	psi	kPa	psi	cm²	in²
Tip Penetration						
12.5 mm (0.5 in)	4727.05	685.6	6989.35	706.7	425.81	66
25 mm (1.0 in)	1347.92	195.5	1827.94	215.7	1445.16	224
38 mm (1.5 in)	902.52	130.9	1094.20	156.8	2077.42	322
50 mm (2.0 in)	658.45	95.5	872.95	97.7	3064.51	475

825K Standard Tip	Weight Front Axle 15 464 kg (34,093 lb) Ground Contact Pressure		Weight Rear Axle 17 439 kg (38,446 lb) Ground Contact Pressure		Contact Area Four Wheels	
	kPa	psi	kPa	psi	cm²	in²
Tip Penetration						
12.7 mm (0.5 in)	7178.41	1041.14	8092.55	1173.73	407.65	63.19
25 mm (1.0 in)	2609.39	378.46	2941.72	426.66	1121.55	173.84
38 mm (1.5 in)	1411.35	204.70	1591.10	230.77	2073.54	321.40
50 mm (2.0 in)	704.99	102.25	794.76	115.27	4150.96	643.40
75 mm (3.0 in)	610.19	88.50	687.89	99.77	4795.60	743.32
100 mm (4.0 in)	421.68	61.16	475.39	68.95	6939.86	1075.68
125 mm (5.0 in)	382.52	55.48	431.27	62.55	7650.04	1185.76
150 mm (6.0 in)	324.33	47.04	365.63	53.03	9022.18	1398.44
175 mm (7.0 in)	311.09	45.12	350.74	50.87	9405.66	1457.88
200 mm (8.0 in)	139.55	20.24	157.34	22.82	20 965.89	3249.72

825K Heavy Duty Tip	Weight Front Axle 15 464 kg (34,093 lb) Ground Contact Pressure		Weight Rear Axle 17 439 kg (38,446 lb) Ground Contact Pressure		Contact Area Four Wheels	
	kPa	psi	kPa	psi	cm²	in²
Tip Penetration						
12.7 mm (0.5 in)	7615.41	1104.52	8585.20	1245.18	96.07	14.89
25 mm (1.0 in)	6199.83	899.21	6989.35	1013.72	472.00	73.16
38 mm (1.5 in)	3614.20	524.19	1915.27	277.79	430.61	66.74
50 mm (2.0 in)	1621.44	235.17	1827.94	265.12	1804.64	279.72
75 mm (3.0 in)	970.64	140.78	1094.20	158.70	3014.96	467.32
100 mm (4.0 in)	774.28	112.30	872.95	126.61	3779.35	585.80
125 mm (5.0 in)	570.89	82.80	643.56	93.34	5126.18	794.56
150 mm (6.0 in)	443.13	64.27	499.59	72.46	6603.60	1023.56
175 mm (7.0 in)	417.06	60.49	470.22	68.20	7016.24	1087.52
200 mm (8.0 in)	389.07	56.43	438.64	63.62	7520.76	1165.72
225 mm (9.0 in)	381.07	55.27	429.61	62.31	7678.95	1190.24
250 mm (10.0 in)	128.59	18.65	145.00	21.03	22 753.76	3526.84

WHEEL LOADERS INTEGRATED TOOLCARRIERS

CONTENTS

Features	23-2
Specifications	23-3
Performance Data	23-16
Machine Dimensions	23-206
SAE Loader Ratings	23-252
Machine Selection:	
Cycle Time Factors	23-254
Truck Loading	23-255
Bucket Fill Factors	23-255
Example Problem	23-256
Alternative Method of Selection	23-257
Nomographs	23-258
Machine/Attachment Selection	23-260
Buckets	23-267
Bucket Selection	23-294
Travel Time Charts	23-324
988K Rimpull-Speed-Gradeability Charts	23-353
Travel Time Charts	23-354
990K Rimpull-Speed-Gradeability Charts	23-356
Travel Time Charts	23-357
992K Rimpull-Speed-Gradeability Charts	23-359
Travel Time Charts	23-361
993K Rimpull-Speed-Gradeability Charts	23-363
Travel Time Charts	23-365
994K Rimpull-Speed-Gradeability Charts	23-369
Travel Time Charts	23-370
Production Estimating Tables:	
Cubic Meters and Cubic Yards	23-372
Metric Tons and U.S. Tons in Shot Rock	23-373
Attachments:	
Wheel Loaders	23-375
Integrated Toolcarriers	23-377
Fusion™ Coupler System	23-378
Attachments	23-379

WHEEL LOADERS

Features:

- Cat® heavy duty diesel engine.
- Productive operator environment. Excellent visibility.
- Automatic lift and bucket controls.
- Adjustable suspension seat and steering column.
- Four wheel enclosed wet disc brakes.
- Automatic power shift transmissions. Allows operator to select automatic or manual mode.
- Hydrostatic drive on 903C, 906K/M, 907K/M, 908K/M, 910K, 914K, 924K, 926M, 930K/M and 938K/M.
- Transmission neutralizer switch (950H-980H, 950K-980K and 950M-982M).
- Advanced power train with continuously variable transmission available on the 966M XE and 972M XE.
- Computerized machine function monitoring (excluding 903C).
- Command control steering with integrated transmission controls and electro-hydraulic controls ... 950H-980H.
- Electro-Hydraulic (EH) Joystick Steering with Force Feedback (Speed Sensitive) on 966K, 966M, 972K, 972M, 980K, 980M and 982M (optional on 950M and 962M).
- Lock up clutch on 950M, 962M, 966M, 972M, 980M, 982M, 988K, 990K and 994K (optional on the 980K, 992K, and 993K).
- Impeller clutch on 988K, 990K, 992K, 993K and 994K.
- Tilting hood ... 950H-980H, 950K-980K and 950M-982M.
- Brake wear indicator.
- Limited slip differentials on 924K, 926M, 930K/M, 938K/M (optional on 950H-980H, 950K-980K, 980M, and 982M).
- Differential locks ... 903C, 906K/M, 907K/M, 908K/M, 910K, 914K, 924K, 926M, 930K/M, 938K/M, 950M, 962M, 966M and 972M.
- Automatic Ride Control suspension system. Operator select “on,” “off” or “automatic” (excluding 903C).
- Payload control system (excluding models below 924K).
- Optional Fusion coupler system for attachment interchangeability with pin-on performance. Attachments can interchange across the entire SWL/MWL/IT line (excluding models below 924K).
- Performance Series Buckets — Reduced dig times and better material retention lead to significant productivity and fuel efficiency improvements (910K, 914K, 924K, 926M, 930K/M, 938K/M, 950H-980H, 950K-980K and 950M-982M).

Listed features may be standard on some models, optional or unavailable on others. Contact your Cat dealer for specific information.

MODEL	903C		
Flywheel Power: Net	30 kW		40 hp
Gross	31 kW		42 hp
Engine Model		C2.4*	
Rated Engine RPM		2200	
Bore	87 mm		3.4"
Stroke	102 mm		4.0"
No. Cylinders		4	
Displacement	2.4 L		147 in ³
Forward Speed	16 km/h		10 mph
Reverse Speed	16 km/h		10 mph
Hydraulic Cycle Time, Rated Load in Bucket:		Seconds	
Raise		4.7	
Dump		0.8	
Lower		3.1	
Total		8.6	
Tread Width	1314 mm		4'4"
Width Over Tires	1708 mm		5'7"
Ground Clearance	395 mm		1'4"
Fuel Tank Capacity	43 L		11.4 U.S. gal
Hydraulic System Capacity (includes tank)	24 L		6.3 U.S. gal

*These machines meet U.S. EPA Tier 4 Interim/EU Stage IIIB equivalent emission standards and are only available in certain regions. Contact your local Cat dealer for product availability.

MODEL	906K/M		907K/M		908K/M	
Flywheel Power: Net	52 kW	70 hp	52 kW	70 hp	52 kW	70 hp
Gross	55 kW	74 hp	55 kW	74 hp	55 kW	74 hp
Engine Model	C3.3B*		C3.3B*		C3.3B*	
Rated Engine RPM	2500		2500		2500	
Bore	94 mm	3.7"	94 mm	3.7"	94 mm	3.7"
Stroke	120 mm	4.72"	120 mm	4.72"	120 mm	4.72"
No. Cylinders	4		4		4	
Displacement	3.331 L	203.3 in³	3.331 L	203.3 in³	3.331 L	203.3 in³
Speeds Forward:	km/h	mph	km/h	mph	km/h	mph
Speed 1	10	6	10	6	10	6
Speed 2	20	12	20	12	20	12
High Speed	35	22	35	22	35	22
Speeds Reverse:	km/h	mph	km/h	mph	km/h	mph
1st	10	6	10	6	10	6
2nd	20	12	20	12	20	12
High Speed	35	22	35	22	35	22
Hydraulic Cycle Time, Rated Load in Bucket:	Seconds		Seconds		Seconds	
Raise	5		5		5	
Dump	2		2		2	
Lower (Empty, Float Down)	4		4		4	
Total	11		11		11	
Tread Width	1420 mm	4'8"	1420 mm	4'8"	1590 mm	5'2"
Width Over Tires	1820 mm	5'11"	1820 mm	5'11"	1993 mm	6'6"
Ground Clearance	301 mm	12"	301 mm	12"	340 mm	14"
Fuel Tank Capacity	52 L	13.7 U.S. gal	78 L	20.6 U.S. gal	78 L	20.6 U.S. gal
Hydraulic Tank Capacity	59 L	15.5 U.S. gal	59 L	15.5 U.S. gal	59 L	15.5 U.S. gal
Hydraulic System Capacity (includes tank)	70 L	18.5 U.S. gal	70 L	18.5 U.S. gal	70 L	18.5 U.S. gal

*Depending on region, these models meet U.S. EPA Tier 4 Final/EU Stage IIIB, U.S. EPA Tier 4 Interim/EU Stage IIIA equivalent, or U.S. EPA Tier 2/EU Stage II equivalent emission standards. Contact your local Cat dealer for product availability.

MODEL	910K			914K		
Flywheel Power:						
Net	70 kW	93 hp		70 kW	93 hp	
Gross (SAE J1995)	73 kW	97 hp		73 kW	97 hp	
Maximum Gross Power:						
ISO 14396	73 kW	98 hp		73 kW	98 hp	
ISO 14396 (DIN)	73 kW	98 hp		73 kW	98 hp	
Rated Net Power:						
SAE J1349	69 kW	92 hp		69 kW	92 hp	
ISO 9249/EEC	70 kW	93 hp		70 kW	93 hp	
ISO 9249 (DIN)	72 kW	96 hp		72 kW	96 hp	
Engine Model	C3.8 Turbo*			C3.8 Turbo*		
Rated Engine RPM	2400			2400		
Bore	100 mm	3.94"		100 mm	3.94"	
Stroke	120 mm	4.72"		120 mm	4.72"	
No. Cylinders	4			4		
Displacement	3.8 L	231.8 in³		3.8 L	231.8 in³	
Speeds Forward:	km/h	mph		km/h	mph	
1st	10	Lo 6.3		10	Lo 6.3	
2nd	20	Lo 12.0		20	Lo 12.0	
High	40	Hi 25.0		40	Hi 25.0	
Speeds Reverse:	km/h	mph		km/h	mph	
1st	10	Lo 6.3		10	Lo 6.3	
2nd	20	Lo 12.0		20	Lo 12.0	
High	40	Hi 25.0		40	Hi 25.0	
Hydraulic Cycle Time, Rated Load in Bucket:	Seconds			Seconds		
Raise	5.9			5.3		
Dump	2.0			1.8		
Lower (Empty, Float Down)	4.4			4.0		
Total	12.3			11.1		
Tread Width	1.80 m	5'11"		1.80 m	5'11"	
Width Over Tires	2.26 m	7'5"		2.26 m	7'5"	
Ground Clearance	348 mm	13"		405 mm	15"	
Fuel Tank Capacity	150 L	39.6 gal		150 L	39.6 gal	
Hydraulic Tank Capacity	60 L	15.9 gal		60 L	15.9 gal	
Hydraulic System Capacity (includes tank)	85 L	22.5 gal		85 L	22.5 gal	

*These machines meet U.S. EPA Tier 4 Interim/EU Stage IIIB equivalent emission standards and are only available in certain regions. Contact your local Cat dealer for product availability.

MODEL	926M*** Standard and High Lift Pin On/Hook On		930M*** Standard and High Lift Pin On/Hook On		938M*** Standard and High Lift Pin On/Hook On	
Flywheel Power	110 kW	148 hp	117 kW	157 hp	136 kW	182 hp
Rated Power	114 kW	153 hp	122 kW	166 hp	140 kW	190 hp
Engine Model	C7.1 ACERT™		C7.1 ACERT		C7.1 ACERT	
Rated Engine RPM	1800		1800		1800	
Bore	105 mm	4.13"	105 mm	4.13"	105 mm	4.13"
Stroke	135 mm	5.31"	135 mm	5.31"	135 mm	5.31"
No. Cylinders	6		6		6	
Displacement	7.01 L	427 in³	7.01 L	427 in³	7.01 L	427 in³
Speeds Forward and Reverse:	km/h	mph	km/h	mph	km/h	mph
1st	1.0-13.0	0.6-8.0	1.0-13.0	0.6-8.0	1.0-13.0	0.6-8.0
2nd	13.0	8.0	13.0	8.0	13.0	8.0
3rd	27.0	17.0	27.0	17.0	27.0	17.0
4th	40.0	25.0	40.0	25.0	40.0	25.0
Hydraulic Cycle Time, Rated Load in Bucket:*	Seconds		Seconds		Seconds	
Raise	5.5		5.5		5.5	
Dump	1.5		1.5		1.5	
Lower (Empty, Float Down)	2.6		2.6		2.6	
Total	9.6		9.6		9.6	
Tread Width**	1.93 m	6'3"	1.93 m	6'3"	2.08 m	6'10"
Width Over Tires**	2.54 m	8'4"	2.54 m	8'4"	2.69 m	8'10"
Ground Clearance**	397 mm	1'4"	397 mm	1'4"	386 mm	1'3"
Fuel Tank Capacity	195 L	51.5 U.S. gal	195 L	51.5 U.S. gal	195 L	51.5 U.S. gal
Hydraulic Tank Capacity	90 L	23.8 U.S. gal	90 L	23.8 U.S. gal	90 L	23.8 U.S. gal
Hydraulic System Capacity (includes tank)	160 L	42.3 U.S. gal	160 L	42.3 U.S. gal	160 L	42.3 U.S. gal

*With standard lift arms.

**With standard tires.

***Meets Tier 4 Final/Stage IV/Japan 2014 (Tier 4 Final) emission standards.

NOTE: Dimensions listed are for a machine configured with Fusion work tool, counterweights, additional guarding, 80 kg (176 lb) operator, and Michelin 20.5 R25 (L-3) XHA2 tires.

MODEL	924K Standard and High Lift Pin On/Hook On		930K Standard and High Lift Pin On/Hook On		938K Standard and High Lift Pin On/Hook On	
Flywheel Power	105 kW	141 hp	119 kW	160 hp	140 kW	188 hp
Rated Power	101 kW	135 hp	115 kW	154 hp	136 kW	182 hp
Engine Model	C7.1 ACERT		C7.1 ACERT		C7.1 ACERT	
Rated Engine RPM	1800		1800		1800	
Bore	105 mm	4.13"	105 mm	4.13"	105 mm	4.13"
Stroke	135 mm	5.31"	135 mm	5.31"	135 mm	5.31"
No. Cylinders	6		6		6	
Displacement	7.01 L	427 in³	7.01 L	427 in³	7.01 L	427 in³
Speeds Forward and Reverse:	km/h	mph	km/h	mph	km/h	mph
1st	1.0-13.0	0.6-8.0	1.0-13.0	0.6-8.0	1.0-13.0	0.6-8.0
2nd	13.0	8.0	13.0	8.0	13.0	8.0
3rd	27.0	17.0	27.0	17.0	27.0	17.0
4th	40.0	25.0	40.0	25.0	40.0	25.0
Hydraulic Cycle Time, Rated Load in Bucket:*	Seconds		Seconds		Seconds	
Raise	5.4		5.1		5.5	
Dump	1.5		1.5		1.5	
Lower (Empty, Float Down)	2.6		2.7		2.7	
Total	9.5		9.3		9.7	
Tread Width**	1.93 m	6'3"	1.93 m	6'3"	2.08 m	6'10"
Width Over Tires**	2.54 m	8'4"	2.54 m	8'4"	2.69 m	8'10"
Ground Clearance**	397 mm	1'4"	397 mm	1'4"	386 mm	1'3"
Fuel Tank Capacity	195 L	51.5 U.S. gal	195 L	51.5 U.S. gal	195 L	51.5 U.S. gal
Hydraulic Tank Capacity	90 L	23.8 U.S. gal	90 L	23.8 U.S. gal	90 L	23.8 U.S. gal
Hydraulic System Capacity (includes tank)	160 L	42.3 U.S. gal	165 L	43.6 U.S. gal	170 L	44.9 U.S. gal

*With standard lift arms.

**With standard tires.

NOTE: Dimensions listed are for a machine configured with Fusion work tool, counterweights, additional guarding, 80 kg (176 lb) operator, and Michelin 20.5 R25 (L-3) XHA2 tires.

MODEL	950M		962M		966M	
Maximum Engine: Net	171 kW	230 hp	186 kW	250 hp	206 kW	276 hp
Gross	187 kW	250 hp	202 kW	271 hp	232 kW	311 hp
Engine Model	C7.1 ACERT		C7.1 ACERT		C9.3 ACERT	
Maximum Net Power Engine RPM	2100		2100		1700	
Bore	105 mm	4.1"	105 mm	4.1"	115 mm	4.53"
Stroke	135 mm	5.3"	135 mm	5.3"	149 mm	5.87"
No. Cylinders	6		6		6	
Displacement	7.01 L	427.8 in³	7.01 L	427.8 in³	9.3 L	568 in³
Speeds Forward:	km/h	mph	km/h	mph	km/h	mph
1st	6.9	4.3	6.9	4.3	6.5	4.0
2nd	12.0	7.5	12.0	7.5	13.0	8.1
3rd	19.3	12.0	19.3	12.0	23.5	14.6
4th	25.7	16.0	25.7	16.0	39.5	24.5
5th	39.5	24.5	39.5	24.5	—	—
Speeds Reverse:	km/h	mph	km/h	mph	km/h	mph
1st	6.9	4.3	6.9	4.3	7.1	4.4
2nd	12.0	7.5	12.0	7.5	14.4	8.9
3rd	25.7	16.0	25.7	16.0	25.9	16.1
4th	—	—	—	—	39.0	24.2
Hydraulic Cycle Time, Rated Load in Bucket:	Seconds		Seconds		Seconds	
Raise	5.1		5.2		6.1	
Dump	1.5		1.5		1.4	
Lower (Empty, Float Down)	2.3		2.7		2.8	
Total	8.9		9.4		10.3	
Tread Width	2140 mm	7'0"	2140 mm	7'0"	2230 mm	7'4"
Width Over Tires	2790 mm	9'2"	2790 mm	9'2"	2991 mm	9'10"
Ground Clearance	385 mm	1'3"	385 mm	1'3"	476 mm	1'7"
Fuel Tank Capacity	135 L	35.7 U.S. gal	135 L	35.7 U.S. gal	313 L	82.7 U.S. gal
DEF Tank Capacity	11 L	2.9 U.S. gal	11 L	2.9 U.S. gal	16.8 L	4.4 U.S. gal
Hydraulic Tank Capacity	125 L	33 U.S. gal	125 L	33 U.S. gal	125 L	33 U.S. gal

NOTE: Net Engine Power is provided according to SAE J1349 and ISO 9249. Gross Engine Power is provided according to SAE J1995. Machines may only be available in certain regions. Contact your local Cat dealer for product availability.

NOTE: These machines meet U.S. EPA Tier 4 Final/EU Stage IV emission standards and are only available in certain regions. Contact your local Cat dealer for product availability.

MODEL	966M XE		972M		972M XE	
Maximum Engine: Net	222 kW	298 hp	223 kW	299 hp	222 kW	298 hp
Gross	—		251 kW	337 hp	—	
Engine Model	C9.3 ACERT		C9.3 ACERT		C9.3 ACERT	
Maximum Net Power Engine RPM	1600		1700		1600	
Bore	115 mm	4.53"	115 mm	4.53"	115 mm	4.53"
Stroke	149 mm	5.87"	149 mm	5.87"	149 mm	5.87"
No. Cylinders	6		6		6	
Displacement	9.3 L	568 in³	9.3 L	568 in³	9.3 L	568 in³
Speeds Forward:	km/h	mph	km/h	mph	km/h	mph
1st	6.7	4.2	6.7	4.2	6.7	4.2
2nd	12.6	7.8	13.1	8.1	12.6	7.8
3rd	22.1	13.7	23.2	14.4	22.1	13.7
4th	39.5	24.5	39.5	24.5	39.5	24.5
5th	—		—		—	
Speeds Reverse:	km/h	mph	km/h	mph	km/h	mph
1st	6.7	4.2	7.6	4.7	6.7	4.2
2nd	12.6	7.8	15.0	8.9	12.6	7.8
3rd	28.0	17.4	26.5	16.5	28.0	17.4
4th	—		39.5	24.5	—	
Hydraulic Cycle Time, Rated Load in Bucket:	Seconds		Seconds		Seconds	
Raise	6.1		6.1		6.1	
Dump	1.4		1.5		1.5	
Lower (Empty, Float Down)	2.8		3.1		3.1	
Total	10.3		10.7		10.7	
Tread Width	2230 mm	7'4"	2230 mm	7'4"	2230 mm	7'4"
Width Over Tires	2991 mm	9'10"	2991 mm	9'10"	2991 mm	9'10"
Ground Clearance	476 mm	1'7"	476 mm	1'7"	476 mm	1'7"
Fuel Tank Capacity	313 L	82.7 U.S. gal	313 L	82.7 U.S. gal	313 L	82.7 U.S. gal
DEF Tank Capacity	16.8 L	4.4 U.S. gal	16.8 L	4.4 U.S. gal	16.8 L	4.4 U.S. gal
Hydraulic Tank Capacity	125 L	33 U.S. gal	125 L	33 U.S. gal	125 L	33 U.S. gal

NOTE: Net Engine Power is provided according to SAE J1349 and ISO 9249. Gross Engine Power is provided according to SAE J1995. Machines may only be available in certain regions. Contact your local Cat dealer for product availability.

NOTE: These machines meet U.S. EPA Tier 4 Final/EU Stage IV emission standards and are only available in certain regions. Contact your local Cat dealer for product availability.

MODEL	980M		982M	
Maximum Engine: Net	288 kW	386 hp	292 kW	392 hp
Gross	317 kW	425 hp	325 kW	436 hp
Engine Model	C13 ACERT		C13 ACERT	
Maximum Net Power Engine RPM	1700		1700	
Bore	130 mm	5.1"	130 mm	5.1"
Stroke	157 mm	6.2"	157 mm	6.2"
No. Cylinders	6		6	
Displacement	12.5 L	762.8 in³	12.5 L	762.8 in³
Speeds Forward:	km/h	mph	km/h	mph
1st	6.9	4.3	6.2	3.9
2nd	13.3	8.3	11.9	7.4
3rd	23.5	14.6	21.1	13.1
4th	39.5	24.5	37.5	23.3
5th	—		—	
Speeds Reverse:	km/h	mph	km/h	mph
1st	7.8	4.8	7.0	4.3
2nd	15.2	9.4	13.6	8.5
3rd	26.9	16.7	24.1	15.0
4th	39.5	24.5	39.5	24.5
Hydraulic Cycle Time, Rated Load in Bucket:	Seconds		Seconds	
Raise	5.3		5.3	
Dump	1.7		1.7	
Lower (Empty, Float Down)	3.1		3.1	
Total	10.1		10.1	
Tread Width	2440 mm	8'0"	2540 mm	8'4"
Width Over Tires	3265 mm	10'9"	3452 mm	11'4"
Ground Clearance	453 mm	1'6"	426 mm	1'5"
Fuel Tank Capacity	441 L	116 U.S. gal	441 L	116 U.S. gal
DEF Tank Capacity	21 L	5.5 U.S. gal	21 L	5.5 U.S. gal
Hydraulic Tank Capacity	180 L	48 U.S. gal	180 L	48 U.S. gal

NOTE: Net Engine Power is provided according to SAE J1349 and ISO 9249. Gross Engine Power is provided according to SAE J1995. Machines may only be available in certain regions. Contact your local Cat dealer for product availability.

NOTE: These machines meet U.S. EPA Tier 4 Final/EU Stage IV emission standards and are only available in certain regions. Contact your local Cat dealer for product availability.

MODEL	950K		962K		966K	
Maximum Engine: Net	157 kW	210 hp	165 kW	222 hp	199 kW	267 hp
Gross	173 kW	232 hp	181 kW	243 hp	222 kW	296 hp
Engine Model	C7.1 ACERT		C7.1 ACERT		C9.3 ACERT	
Maximum Net Power Engine RPM	1900		1900		1800	
Bore	105 mm	4.1"	105 mm	4.1"	115 mm	4.5"
Stroke	135 mm	5.3"	135 mm	5.3"	149 mm	5.9"
No. Cylinders	6		6		6	
Displacement	7.01 L	427.8 in³	7.01 L	427.8 in³	9.3 L	568 in³
Speeds Forward:	km/h	mph	km/h	mph	km/h	mph
1st	6.9	4.3	6.9	4.3	6.7	4.2
2nd	12.9	8.0	12.9	8.0	12.6	7.8
3rd	22.7	14.1	22.7	14.1	22.4	13.9
4th	37.9	23.6	37.9	23.6	37.4	23.2
Speeds Reverse:	km/h	mph	km/h	mph	km/h	mph
1st	7.5	4.7	7.5	4.7	7.8	4.9
2nd	14.1	8.8	14.1	8.8	13.7	8.5
3rd	24.8	15.4	24.8	15.4	23.5	14.6
4th	39.8	24.7	39.8	24.7	38.5	23.9
Hydraulic Cycle Time, Rated Load in Bucket:	Seconds		Seconds		Seconds	
Raise	5.9		5.9		5.9	
Dump	1.8		1.8		1.5	
Lower (Empty, Float Down)	2.5		2.5		2.4	
Total	10.0		10.0		9.8	
Tread Width	2.14 m	7'0"	2.14 m	7'0"	2.23 m	7'4"
Width Over Tires	2.79 m	9'2"	2.79 m	9'2"	3.01 m	9'11"
Ground Clearance	397 mm	1'3"	397 mm	1'3"	475 mm	1'6"
Fuel Tank Capacity	314 L	83 U.S. gal	314 L	83 U.S. gal	381 L	101 U.S. gal
Hydraulic Tank Capacity	137 L	36 U.S. gal	137 L	36 U.S. gal	137 L	36 U.S. gal
Hydraulic System Capacity (includes tank)	189 L	50 U.S. gal	189 L	50 U.S. gal	200 L	52 U.S. gal

NOTE: Net Engine Power is provided according to SAE J1349 and ISO 9249. Gross Engine Power is provided according to SAE J1995. Machines may only be available in certain regions. Contact your local Cat dealer for product availability.

NOTE: These machines meet U.S. EPA Tier 4 Interim/EU Stage IIIB equivalent emission standards and are only available in certain regions. Contact your local Cat dealer for product availability.

MODEL	972K		980K		988K	
Maximum Engine: Net	215 kW	289 hp	274 kW	369 hp	403 kW	541 hp
Gross	237 kW	318 hp	303 kW	407 hp	432 kW	580 hp
Rated Payload*	—		—		11.3 tonnes	12.5 tons
Gross Rated Bucket Payload*	—		—		17 070 kg	37,632 lb
Engine Model	C9.3 ACERT		C13 ACERT		C18 ACERT	
Maximum Net Power Engine RPM	1800		1600		1700	
Bore	115 mm	4.5"	130 mm	5.1"	145 mm	5.7"
Stroke	149 mm	5.9"	157 mm	6.2"	183 mm	7.2"
No. Cylinders	6		6		6	
Displacement	9.3 L	568 in³	12.5 L	762.8 in³	18.1 L	1104.5 in³
Speeds Forward:	km/h	mph	km/h	mph	km/h	mph
1st	7.0	4.4	6.9	4.3	6.5	4.0
2nd	12.5	7.8	12.2	7.6	11.6	7.2
3rd	21.4	13.3	21.3	13.2	20.4	12.7
4th	36.9	22.9	37.2	23.1	34.7	21.6
Speeds Reverse:	km/h	mph	km/h	mph	km/h	mph
1st	8.0	5.0	7.8	4.8	7.5	4.7
2nd	14.3	8.9	13.8	8.6	13.3	8.3
3rd	24.5	15.2	24.2	15.1	23.2	14.4
4th	42.2	26.2	42.4	26.3	—	
Hydraulic Cycle Time, Rated Load in Bucket:	Seconds		Seconds		Seconds	
Raise	5.9		6.4		8.0	
Dump	2.0		1.7		2.2	
Lower (Empty, Float Down)	2.4		3.3		3.5	
Total	10.3		11.4		13.7	
Tread Width	2.23 m	7'4"	2.44 m	8'0"	2.59 m	8'6"
Width Over Tires	3.02 m	9'11"	3307 mm	10'9"	3.62 m	11'11"
Ground Clearance	475 mm	1'6"	460 mm	1'6"	556 mm	22"
Fuel Tank Capacity	381 L	101 U.S. gal	447 L	118.1 U.S. gal	712 L	188 U.S. gal
Hydraulic Tank Capacity	137 L	36 U.S. gal	156 L	41 U.S. gal	240 L	63 U.S. gal
Hydraulic System Capacity (includes tank)	200 L	52 U.S. gal	271 L	72 U.S. gal	475 L	125 U.S. gal

*Changes in bucket weight, including field installed wear iron, can impact rated payload. Consult your Cat dealer for assistance in selecting and configuring the proper bucket for the application. The Cat Large Wheel Loader Payload Policy is a guideline intended to maximize wheel loader structural and component life. The Cat Payload Policy is that the "Gross Bucket plus Payload Capacity" is the MAXIMUM weight that should be carried on the end of the Lift Arm/Boom.

NOTE: For 972K and 980K, Net Engine Power is provided according to SAE J1349 and ISO 9249. Gross Engine Power is provided according to SAE J1995.

NOTE: The 972K and 980K meet U.S. EPA Tier 4 Interim/EU Stage IIIb equivalent emission standards and are only available in certain regions. Contact your local Cat dealer for product availability.

NOTE: The 988K meets U.S. EPA Tier 4 Final/EU Stage IV OR Tier 3/Stage IIIA equivalent OR Tier 2/Stage II equivalent emission standards.

MODEL	950 GC		950H		962H		966H	
Maximum Engine: Net	154 kW	207 hp	147 kW	197 hp	156 kW	209 hp	195 kW	262 hp
Gross	171 kW	229 hp	162 kW	217 hp	172 kW	231 hp	211 kW	283 hp
Engine Model	C7.1		C7 ACERT		C7 ACERT		C11 ACERT	
Maximum Net Power	2000		1800		1800		1800	
Engine RPM	2000		1800		1800		1800	
Bore	105 mm	4.1"	110 mm	4.3"	110 mm	4.3"	130 mm	5.1"
Stroke	135 mm	5.3"	127 mm	5"	127 mm	5"	140 mm	5.5"
No. Cylinders	6		6		6		6	
Displacement	7.01 L	427.8 in³	7.2 L	439 in³	7.2 L	439 in³	11.1 L	677 in³
Speeds Forward:	km/h	mph	km/h	mph	km/h	mph	km/h	mph
1st	7.0	4.3	6.9	4.3	7.0	4.4	6.7	4.2
2nd	12.5	7.8	12.7	7.9	13.0	8.1	12.6	7.8
3rd	22.0	13.7	22.3	13.9	22.6	14.0	22.1	13.7
4th	34.0	21.1	37.0	23.0	38.0	23.6	37.4	23.2
Speeds Reverse:	km/h	mph	km/h	mph	km/h	mph	km/h	mph
1st	7.0	4.3	7.6	4.7	7.6	4.7	7.4	4.6
2nd	12.5	7.8	13.9	8.6	13.9	8.6	13.9	8.6
3rd	22.0	13.7	24.5	15.2	24.5	15.2	24.3	15.1
4th	—		40.0	24.9	40.0	24.9	37.4	23.2
Hydraulic Cycle Time, Rated Load in Bucket:	Seconds		Seconds		Seconds		Seconds	
Raise	6.1		6.2		6.2		5.9	
Dump	1.2		2.0		2.0		1.6	
Lower (Empty, Float Down)	2.8		2.5		2.5		2.4	
Total	10.1		10.7		10.7		9.9	
Tread Width	2.15 m	7'0"	2.14 m	7'0"	2.14 m	7'0"	2.23 m	7'4"
Width Over Tires	2.75 m	9'0"	2.79 m	9'2"	2.79 m	9'2"	3.06 m	9'10"
Ground Clearance	460 mm	1'6"	412 mm	16"	412 mm	16"	434 mm	17"
Fuel Tank Capacity	290 L	77 U.S. gal	264 L	70 U.S. gal	264 L	70 U.S. gal	380 L	100 U.S. gal
Hydraulic Tank Capacity	120 L	32 U.S. gal	110 L	29 U.S. gal	110 L	29 U.S. gal	110 L	29 U.S. gal
Hydraulic System Capacity (includes tank)	190 L	50 U.S. gal	186 L	48.4 U.S. gal	186 L	48.4 U.S. gal	200 L	52 U.S. gal

NOTE: Net Engine Power is provided according to SAE J1349 and ISO 9249. Gross Engine Power is provided according to SAE J1995 for all models except for the 950 GC, which is ISO 14396. Machines may only be available in certain regions. Contact your local Cat dealer for product availability.

NOTE: These machines meet U.S. EPA Tier 3/EU Stage IIIA equivalent emission standards and are only available in certain regions. Contact your local Cat dealer for product availability.

MODEL	972H		980H		986H		990K	
Maximum Engine: Net	214 kW	287 hp	260 kW	349 hp	305 kW	409 hp	521 kW	699 hp
Gross	232 kW	311 hp	293 kW	392 hp	335 kW	449 hp	561 kW	752 hp
Rated Payload*	—	—	—	—	10 tonnes	11 tons	15.9 tonnes	17.5 tons
Gross Rated Bucket Payload*	—	—	—	—	—	—	24 249 kg	53,460 lb
Engine Model	C13 ACERT		C15 ACERT		C15 ACERT		C27 ACERT	
Maximum Net Power	1800		1800		1800		1800	
Engine RPM	1800		1800		1800		1800	
Bore	130 mm	5.1"	137 mm	5.4"	137 mm	5.4"	137 mm	5.4"
Stroke	157 mm	6.2"	171 mm	6.75"	171 mm	6.75"	152 mm	6"
No. Cylinders	6		6		6		12	
Displacement	12.5 L	763 in³	15.2 L	928 in³	15.2 L	928 in³	27.0 L	1650 in³
Speeds Forward:	km/h	mph	km/h	mph	km/h	mph	km/h	mph
1st	7.2	4.5	6.6	4.1	7.3	5	7.3	4.5
2nd	12.6	7.8	11.8	7.3	12.7	8	13.3	8.3
3rd	21.4	13.3	20.7	12.9	22	14	22.9	14.2
4th	36.9	22.9	36.3	22.6	39	24	—	—
Speeds Reverse:	km/h	mph	km/h	mph	km/h	mph	km/h	mph
1st	8.2	5.1	7.6	4.7	7.6	5	7.9	4.9
2nd	14.2	8.8	13.5	8.4	14.1	9	14.7	9.1
3rd	24.3	15.1	23.6	14.7	25	12	24.9	15.5
4th	38.8	24.0	41.5	25.8	—	—	—	—
Hydraulic Cycle Time, Rated Load in Bucket:	Seconds		Seconds		Seconds		Seconds	
Raise	5.9		6.0		8.5		8.2	
Dump	2.1		2.1		3		2.9	
Lower (Empty, Float Down)	2.4		3.4		4.3		3.6	
Total	10.4		11.5		15.8		13.8	
Tread Width	2.23 m	7'4"	2.43 m	8'0"	2.59 m	8'6"	3.1 m	10'2"
Width Over Tires	3.00 m	9'10"	3.18 m	10'5"	3.54 m	11'7"	4.1 m	13'5"
Ground Clearance	434 mm	17"	430 mm	16.9"	459 mm	18"	596 mm	23.5"
Fuel Tank Capacity	380 L	100 U.S. gal	453 L	120 U.S. gal	600 L	159 U.S. gal	1114 L	294 U.S. gal
Hydraulic Tank Capacity	110 L	29 U.S. gal	125 L	33 U.S. gal	130 L	34 U.S. gal	—	—
Implement and Fan	—	—	—	—	—	—	261 L	68.9 U.S. gal
Steering and Braking	—	—	—	—	—	—	132 L	34.9 U.S. gal
Hydraulic System Capacity (includes tank)	200 L	52 U.S. gal	250 L	66 U.S. gal	330 L	87 U.S. gal	795 L	210 U.S. gal

*Changes in bucket weight, including field installed wear iron, can impact rated payload. Consult your Cat dealer for assistance in selecting and configuring the proper bucket for the application. The Cat Large Wheel Loader Payload Policy is a guideline intended to maximize wheel loader structural and component life. The Cat Payload Policy is that the "Gross Bucket plus Payload Capacity" is the MAXIMUM weight that should be carried on the end of the Lift Arm/Boom.

NOTE: 972H and 980H Net Engine Power is provided according to SAE J1349 and ISO 9249. Gross Engine Power is provided according to SAE J1995. The 972H and 980H are not available in all regions. Contact your local Cat dealer for product availability.

NOTE: The 972H and 980H meet U.S. EPA Tier 3/EU Stage IIIA equivalent emission standards and are only available in certain regions. Contact your local Cat dealer for product availability.

NOTE: The 986H meets Tier 2/Stage II/Japan 2001 (Tier 2) equivalent OR Tier 3/Stage IIIA/Japan 2006 (Tier 3) equivalent emission standards.

NOTE: The 990K meets Tier 2/Stage II/Japan 2001 (Tier 2) equivalent OR Tier 4 Final/Stage IV/Japan 2014 (Tier 4 Final) emission standards.

MODEL	992K		993K		994K	
Maximum Engine: Net	607 kW	814 hp	764 kW	1024 hp	1297 kW	1739 hp
Gross	671 kW	900 hp	773 kW	1036 hp	1377 kW	1847 hp
Rated Payload:*						
STD	21.8 tonnes	24 tons	22.7 tonnes	30 tons	40.8 tonnes	45 tons
HL, EHL, SHL	19 tonnes	21 tons	24.9 tonnes	27.5 tons	38.1 tonnes	42 tons
Gross Rated Bucket Payload:*						
STD	33 687 kg	74,265 lb	42 912 kg	94,603 lb	64 791 kg	142,838 lb
HL	30 138 kg	66,441 lb	40 459 kg	89,195 lb	61 458 kg	135,489 lb
Engine Model	C32 ACERT**		C32 ACERT**		3516E	
Emission Level						
Rated Engine RPM	1750		1900		1600	
Bore	145 mm	5.7"	145 mm	5.7"	170 mm	6.7"
Stroke	162 mm	6.4"	162 mm	6.4"	215 mm	8.5"
No. Cylinders	12		12		16	
Displacement	32.1 L	1959 in³	32.1 L	1959 in³	78 L	4766 in³
Speeds Forward:	km/h	mph	km/h	mph	km/h	mph
1st	7.1	4.4	6.8	4.2	7.4	4.6
2nd	12.2	7.6	11.9	7.4	12.9	8.0
3rd	20.6	12.8	20.5	12.7	24.0	14.9
Speeds Reverse:	km/h	mph	km/h	mph	km/h	mph
1st	7.4	4.6	7.5	4.7	8.1	5.0
2nd	13.0	8.1	13.1	8.1	14.1	8.8
3rd	22.4	13.9	22.5	13.9	24.0	14.9
Hydraulic Cycle Time, Rated Load in Bucket:	Seconds		Seconds		Seconds	
Raise	9.4		9.2		12.6	
Dump	1.8		1.8		3.1	
Lower (Empty, Float Down)	3.7		3.1		4.2	
Total	14.9		14.1		19.9	
Tread Width	3.3 m	10'10"	3.54 m	11'6"	4.3 m	14'1"
Width Over Tires	4.5 m	14'9"	4.93 m	16'2"	5.49 m	18'10"
Ground Clearance	682 mm	26.8"	721 mm	2'5"	898 mm	33"
Fuel Tank Capacity	1610 L	425 U.S. gal	2170 L	573 U.S. gal	3445 L	910 U.S. gal
Hydraulic Systems:						
Lift, Tilt	646 L	171 U.S. gal	755 L	199 U.S. gal	1022 L	270 U.S. gal
Tank Only	326 L	86 U.S. gal	553 L	146 U.S. gal	756 L	200 U.S. gal
Steering and Brakes	231 L	61 U.S. gal	227 L	60 U.S. gal	379 L	100 U.S. gal
Tank Only	159 L	42 U.S. gal	185 L	48.9 U.S. gal	340 L	90 U.S. gal

*Changes in bucket weight, including field installed wear iron, can impact rated payload. Consult your Cat dealer for assistance in selecting and configuring the proper bucket for the application. The Cat Large Wheel Loader Payload Policy is a guideline intended to maximize wheel loader structural and component life. The Cat Payload Policy is that the "Gross Bucket plus Payload Capacity" is the MAXIMUM weight that should be carried on the end of the Lift Arm/Boom.

**Products available to meet Tier 2/Stage II/Japan 2001 (Tier 2) equivalent OR Tier 4 Final/Stage IV/Japan 2014 (Tier 4 Final).

NOTE: The 994K meets U.S. EPA Tier 1 equivalent emission standards.

Bucket Type	General Purpose	
Ground Engaging Type	Bolt-on Cutting Edges	
Rated capacity	m ³	0.6
	yd ³	0.8
Width: bucket	mm	1770
	in	70
Nominal material density, 100% fill factor	kg/m ³	1474
	lb/yd ³	2437
Clearance: full lift, 45° dump	mm	2430
	ft/in	8'0"
Reach: full lift, 45° dump	mm	885
	ft/in	2'11"
Reach: level arm, level bucket	mm	1635
	ft/in	5'4"
Dig depth	mm	200
	in	8
Length: overall	mm	4835
	ft/in	15'10"
Height: overall	mm	2510
	ft/in	8'3"
Turning radius, bucket at carry	mm	4020
	ft/in	13'2"
Tipping load — straight, ISO 14397-1*	kg	2268
	lb	5000
Tipping load — full turn, ISO 14397-1*	kg	1905
	lb	4200
Breakout force	kg	2345
	kN	23
	lbf	5171
Operating weight	kg	4300
	lb	9500

*Full compliance to ISO 14397-1 (2007) Sections 1 thru 6, which requires 2% verification between calculation and testing.

NOTE: Operating specifications and dimensions shown are based on 903C equipped with enclosed ROPS cab with air conditioning, quick coupler, additional counterweight, 75 kg (**165 lb**) operator and general purpose bucket (GP) unless otherwise noted.

Performance Data
 ● 906K/M
 ● Vertical Coupler

Wheel Loaders
 Integrated Toolcarriers

Bucket Type		General Purpose			Multi-Purpose			Light Material	
		Bare	Bolt-on Cutting Edges	Bolt-on Teeth	Bare	Bolt-on Cutting Edges	Bolt-on Teeth	Bolt-on Cutting Edges	
Ground Engaging Type									
	Rated bucket capacity (\$)	m ³	0.9	0.9	0.9	0.75	0.75	0.75	1.2
		yd ³	1.18	1.18	1.18	1.0	1.0	1.0	1.56
Struck capacity (\$)		m ³	0.75	0.75	0.75	0.6	0.6	0.6	1.0
		yd ³	1.0	1.0	1.0	0.8	0.8	0.8	1.31
Bucket width		mm	1880	1890	1880	1880	1890	1880	2080
		ft/in	6'2"	6'2"	6'2"	6'2"	6'2"	6'2"	6'10"
Dump clearance at full lift and 45° discharge (\$)		mm	2393	2359	2393	2468	2434	2468	2395
		ft/in	7'8"	7'8"	7'8"	8'1"	8'0"	8'1"	7'10"
Reach at full lift and 45° discharge (\$)		mm	809	820	809	758	770	758	803
		ft/in	2'8"	2'8"	2'8"	2'6"	2'6"	2'6"	2'8"
Reach at 45° discharge and 2130 mm (7'0") clearance (\$)		mm	1035	1050	1035	970	986	970	1030
		ft/in	2'8"	2'8"	2'8"	2'8"	2'8"	2'8"	3'5"
Reach with lift arms horizontal and bucket level		mm	2000	2033	2000	1919	1952	1919	2144
		ft/in	6'7"	6'8"	6'7"	6'4"	6'5"	6'4"	7'0"
Digging depth (\$)		mm	91	107	91	85	101	85	104
		in	3.6	4.2	3.6	3.3	4.0	3.3	4.0
Overall length		mm	5586	5620	5586	5497	5530	5497	5730
		ft/in	18'4"	18'4"	18'4"	18'0"	18'2"	18'0"	18'10"
Overall height with bucket at full raise (\$)		mm	4192	4192	4192	4176	4176	4176	4257
		ft/in	13'9"	13'9"	13'9"	13'8"	13'8"	13'8"	14'0"
Loader clearance circle with bucket in carry position		mm	8890	8928	8890	8832	8868	8832	9132
		ft/in	29'2"	29'3"	29'2"	29'0"	29'1"	29'0"	30'0"
Static tipping load, straight* (\$)		kg	4128	3932	4021	4184	4009	4086	3796
		lb	9098	8666	8862	9221	8835	9005	8366
Static tipping load, full turn* (\$)		kg	3363	3204	3276	3409	3266	3329	3092
		lb	7412	7061	7220	7513	7198	7337	6814
Breakout force (\$)		kN	43	41	38	47	45	42	38
		lbf	9666	9216	8541	10,564	10,115	9440	8541
Operating weight*		kg	5560	5595	5573	5701	5765	5742	5663
		lb	12,254	12,331	12,282	12,565	12,706	12,655	12,481

*Static tipping load and operating weights shown are with implements, ROPS cab, 12.5-20 tires, full fuel tank and 80 kg (176 lb) operator.
 NOTE: Specifications and ratings conform to all applicable standards recommended by the Society of Automotive Engineers (SAE). SAE Standards J732 JUN92 and J742 FEB85 govern loader rating, denoted in the text by (\$).

Wheel Loaders Integrated Toolcarriers

Performance Data

- 906K/M
- Horizontal Coupler

Bucket Type		General Purpose			Multi-Purpose			Light Material
		Bare	Bolt-on Cutting Edges	Bolt-on Teeth	Bare	Bolt-on Cutting Edges	Bolt-on Teeth	Bolt-on Cutting Edges
Ground Engaging Type								
Rated bucket capacity (\$)	m ³	0.9	0.9	0.9	0.75	0.75	0.75	1.2
	yd ³	1.18	1.18	1.18	0.98	0.98	0.98	1.56
Struck capacity (\$)	m ³	0.75	0.75	0.75	0.6	0.6	0.6	1.0
	yd ³	0.98	0.98	0.98	0.78	0.78	0.78	1.31
Bucket width	mm	1880	1890	1880	1880	1890	1880	2080
	ft/in	6'2"	6'2"	6'2"	6'2"	6'2"	6'2"	6'10"
Dump clearance at full lift and 45° discharge (\$)	mm	2513	2478	2437	2500	2465	2428	2429
	ft/in	8'3"	8'2"	8'0"	8'2"	8'1"	8'0"	8'0"
Reach at full lift and 45° discharge (\$)	mm	714	725	785	704	715	775	792
	ft/in	2'4"	2'5"	2'7"	2'4"	2'4"	2'7"	2'7"
Reach at 45° discharge and 2130 mm (7'0") clearance (\$)	mm	914	928	1005	901	915	992	1014
	ft/in	3'0"	3'1"	3'4"	2'11"	3'0"	3'3"	3'4"
Reach with lift arms horizontal and bucket level	mm	1851	1883	1953	1858	1891	1960	1994
	ft/in	6'1"	6'2"	6'5"	6'1"	6'2"	6'5"	6'7"
Digging depth (\$)	mm	79	95	79	90	106	90	83
	in	3.0	4.0	3.0	4.0	4.0	4.0	3.3
Overall length	mm	5436	5469	5538	5436	5436	5538	5580
	ft/in	17'10"	17'11"	18'2"	17'10"	17'10"	18'2"	18'4"
Overall height with bucket at full raise (\$)	mm	4077	4077	4077	4134	4134	4134	4141
	ft/in	13'5"	13'5"	13'5"	13'7"	13'7"	13'7"	13'7"
Loader clearance circle with bucket in carry position	mm	8802	8840	8784	8812	8848	8792	9042
	ft/in	28'11"	29'0"	28'10"	28'11"	29'0"	28'10"	29'8"
Static tipping load, straight* (\$)	kg	4380	4219	4317	4288	4110	4188	4068
	lb	9653	9298	9514	9450	9058	9230	8965
Static tipping load, full turn* (\$)	kg	3568	3437	3517	3493	3348	3412	3314
	lb	7863	7575	7751	7698	7378	7520	7304
Breakout force (\$)	kN	51	49	45	52	49	45	43
	lbf	11,463	11,014	10,115	11,688	11,014	10,115	9665
Operating weight*	kg	5545	5581	5559	5707	5772	5750	5649
	lb	12,221	12,300	12,252	12,578	12,721	12,673	12,450

*Static tipping load and operating weights shown are with implements, ROPS cab, 12.5-20 tires, full fuel tank and 80 kg (176 lb) operator.
NOTE: Specifications and ratings conform to all applicable standards recommended by the Society of Automotive Engineers (SAE). SAE Standards J732 JUN92 and J742 FEB85 govern loader rating, denoted in the text by (\$).

Performance Data
 ● 907K/M
 ● Vertical Coupler

Wheel Loaders
 Integrated Toolcarriers

Bucket Type	General Purpose			Multi-Purpose			Light Material	
		Bare	Bolt-on Cutting Edges	Bolt-on Teeth	Bare	Bolt-on Cutting Edges	Bolt-on Teeth	Bolt-on Cutting Edges
Ground Engaging Type								
Rated bucket capacity (\$)	m ³	1.0	1.0	1.0	0.75	0.75	0.75	1.2
	yd ³	1.31	1.31	1.31	1.0	1.0	1.0	1.56
Struck capacity (\$)	m ³	0.8	0.8	0.8	0.6	0.6	0.6	1.0
	yd ³	1.05	1.05	1.05	0.8	0.8	0.8	1.31
Bucket width	mm	2035	2045	2035	1880	1890	1880	2080
	ft/in	6'8"	6'9"	6'8"	6'2"	6'2"	6'2"	6'10"
Dump clearance at full lift and 45° discharge (\$)	mm	2393	2359	2321	2468	2434	2397	2395
	ft/in	7'10"	7'9"	7'7"	8'1"	8'0"	7'10"	7'10"
Reach at full lift and 45° discharge (\$)	mm	809	820	880	758	770	830	803
	ft/in	2'8"	2'8"	2'11"	2'6"	2'6"	2'9"	2'8"
Reach at 45° discharge and 2130 mm (7'0") clearance (\$)	mm	1035	1050	1100	970	986	1036	1027
	ft/in	3'5"	3'5"	3'7"	3'2"	3'3"	3'5"	3'4"
Reach with lift arms horizontal and bucket level	mm	2000	2033	2102	1919	1952	2021	2144
	ft/in	6'7"	6'8"	6'11"	6'4"	6'5"	6'8"	7'0"
Digging depth (\$)	mm	91	107	91	85	101	85	104
	in	3.6	4.2	3.6	3.4	4.0	3.4	4.1
Overall length	mm	5586	5620	5690	5497	5530	5599	5730
	ft/in	18'4"	18'5"	18'8"	18'0"	18'2"	18'4"	18'10"
Overall height with bucket at full raise (\$)	mm	4192	4192	4192	4176	4176	4176	4257
	ft/in	13'9"	13'9"	13'9"	13'8"	13'8"	13'8"	14'0"
Loader clearance circle with bucket in carry position	mm	9030	9068	9016	8832	8868	8812	9132
	ft/in	29'8"	29'9"	29'7"	29'0"	29'1"	28'11"	30'0"
Static tipping load, straight* (\$)	kg	4268	4110	4195	4391	4211	4290	3984
	lb	9409	9058	9245	9677	9281	9455	8780
Static tipping load, full turn* (\$)	kg	3477	3349	3418	3577	3430	3495	3245
	lb	7665	7381	7533	7883	7559	7702	7151
Breakout force (\$)	kN	43	41	38	47	45	42	38
	lbf	9666	9216	8541	10,564	10,115	9440	8541
Operating weight*	kg	5745	5783	5762	5871	5934	5912	5833
	lb	12,661	12,745	12,699	12,939	13,078	13,030	12,855

*Static tipping load and operating weights shown are with implements, ROPS cab, 12.5-20 tires, full fuel tank and 80 kg (176 lb) operator.
NOTE: Specifications and ratings conform to all applicable standards recommended by the Society of Automotive Engineers (SAE). SAE Standards J732 JUN92 and J742 FEB85 govern loader rating, denoted in the text by (\$).

Wheel Loaders Integrated Toolcarriers

Performance Data

- 907K/M
- Horizontal Coupler

Bucket Type		General Purpose			Multi-Purpose			Light Material
		Bare	Bolt-on Cutting Edges	Bolt-on Teeth	Bare	Bolt-on Cutting Edges	Bolt-on Teeth	Bolt-on Cutting Edges
Ground Engaging Type								
Rated bucket capacity (\$)	m ³	1.0	1.0	1.0	0.75	0.75	0.75	1.2
	yd ³	1.31	1.31	1.31	0.98	0.98	0.98	1.56
Struck capacity (\$)	m ³	0.75	0.75	0.75	0.6	0.6	0.6	1.0
	yd ³	0.98	0.98	0.98	0.78	0.78	0.78	1.31
Bucket width	mm	2035	2045	2035	1880	1890	1880	2080
	ft/in	6'8"	6'9"	6'8"	6'2"	6'2"	6'2"	6'10"
Dump clearance at full lift and 45° discharge (\$)	mm	2513	2478	2437	2500	2465	2428	2429
	ft/in	8'3"	8'2"	8'0"	8'2"	8'1"	8'0"	8'0"
Reach at full lift and 45° discharge (\$)	mm	714	725	785	704	715	775	792
	ft/in	2'4"	2'5"	2'7"	2'4"	2'4"	2'7"	2'7"
Reach at 45° discharge and 2130 mm (7'0") clearance (\$)	mm	914	928	1005	900	915	992	1014
	ft/in	3'0"	3'1"	3'4"	2'11"	3'0"	3'3"	3'4"
Reach with lift arms horizontal and bucket level	mm	1851	1883	1953	1858	1891	1960	1994
	ft/in	6'1"	6'2"	6'5"	6'1"	6'2"	6'5"	6'7"
Digging depth (\$)	mm	79	95	79	90	106	90	83
	in	3.1	3.7	3.1	3.5	4.2	3.5	3.0
Overall length	mm	5436	5469	5538	5436	5469	5538	5580
	ft/in	17'10"	17'11"	18'2"	17'10"	17'11"	18'2"	18'4"
Overall height with bucket at full raise (\$)	mm	4077	4077	4077	4134	4134	4134	4141
	ft/in	13'5"	13'5"	13'5"	13'7"	13'7"	13'7"	13'7"
Loader clearance circle with bucket in carry position	mm	8946	8978	8784	8812	8848	8792	9042
	ft/in	29'4"	29'5"	28'10"	28'11"	29'0"	28'10"	29'8"
Static tipping load, straight* (\$)	kg	4584	4408	4503	4499	4316	4397	4267
	lb	10,103	9715	9924	9915	9512	9690	9404
Static tipping load, full turn* (\$)	kg	3734	3591	3668	3665	3516	3582	3476
	lb	8229	7914	8084	8077	7749	7894	7661
Breakout force (\$)	kN	52	49	45	52	49	45	43
	lbf	11,689	11,014	10,115	11,688	11,014	10,115	9665
Operating weight*	kg	5730	5769	5748	5877	5942	5920	5818
	lb	12,628	12,714	12,668	12,952	13,096	13,047	12,822

*Static tipping load and operating weights shown are with implements, ROPS cab, 12.5-20 tires, full fuel tank and 80 kg (176 lb) operator.

NOTE: Specifications and ratings conform to all applicable standards recommended by the Society of Automotive Engineers (SAE). SAE Standards J732 JUN92 and J742 FEB85 govern loader rating, denoted in the text by (\$).

Performance Data
 ● 908K/M
 ● Vertical Coupler

Wheel Loaders
 Integrated Toolcarriers

Bucket Type		General Purpose			Multi-Purpose			Light Material
		Bare	Bolt-on Cutting Edges	Bolt-on Teeth	Bare	Bolt-on Cutting Edges	Bolt-on Teeth	Bolt-on Cutting Edges
Ground Engaging Type								
Rated bucket capacity (\$)	m ³	1.1	1.1	1.1	0.9	0.9	0.9	1.5
	yd ³	1.44	1.44	1.44	1.18	1.18	1.18	1.96
Struck capacity (\$)	m ³	0.9	0.9	0.9	0.75	0.75	0.75	1.25
	yd ³	1.18	1.18	1.18	1.0	1.0	1.0	1.64
Bucket width	mm	2060	2080	2060	2060	2080	2060	2080
	ft/in	6'9"	6'10"	6'9"	6'9"	6'10"	6'9"	6'10"
Dump clearance at full lift and 45° discharge (\$)	mm	2539	2505	2467	2627	2593	2556	2346
	ft/in	8'4"	8'3"	8'1"	8'7"	8'6"	8'5"	7'8"
Reach at full lift and 45° discharge (\$)	mm	854	866	926	788	800	861	1025
	ft/in	2'10"	2'10"	3'0"	2'7"	2'7"	2'10"	3'4"
Reach at 45° discharge and 2130 mm (7'0") clearance (\$)	mm	1093	1109	1169	1010	1024	1085	1312
	ft/in	3'7"	3'8"	3'10"	3'4"	3'4"	3'7"	4'4"
Reach with lift arms horizontal and bucket level	mm	2149	2181	2251	2039	2072	2141	2405
	ft/in	7'1"	7'2"	7'5"	6'8"	6'10"	7'0"	7'11"
Digging depth (\$)	mm	93	109	93	101	117	101	109
	in	3.7	4.3	3.7	4.0	4.6	4.0	4.3
Overall length	mm	5747	5780	5849	5643	5670	5740	6004
	ft/in	18'10"	19'0"	19'2"	18'6"	18'7"	18'10"	19'8"
Overall height with bucket at full raise (\$)	mm	4415	4415	4415	4392	4392	4392	4547
	ft/in	14'6"	14'6"	14'6"	14'5"	14'5"	14'5"	14'11"
Loader clearance circle with bucket in carry position	mm	9118	9158	9110	9042	9080	9030	9298
	ft/in	29'11"	30'1"	29'11"	29'8"	29'9"	29'8"	30'6"
Static tipping load, straight* (\$)	kg	4580	4427	4526	4721	4530	4618	4256
	lb	10,094	9757	9975	10,405	9984	10,178	9380
Static tipping load, full turn* (\$)	kg	3731	3606	3687	3846	3690	3762	3467
	lb	8223	7947	8126	8476	8132	8291	7641
Breakout force (\$)	kN	51	46	43	54	52	48	38
	lbf	11,464	10,339	9665	12,138	11,688	10,789	8541
Operating weight*	kg	6325	6364	6338	6469	6534	6508	6435
	lb	13,940	14,026	13,968	14,262	14,400	14,343	14,182

*Static tipping load and operating weights shown are with implements, ROPS cab, 12.5-20 tires, full fuel tank and 80 kg (176 lb) operator.
 NOTE: Specifications and ratings conform to all applicable standards recommended by the Society of Automotive Engineers (SAE). SAE Standards J732 JUN92 and J742 FEB85 govern loader rating, denoted in the text by (\$).

Wheel Loaders Integrated Toolcarriers

Performance Data

- 908K/M
- Horizontal Coupler

Bucket Type		General Purpose			Multi-Purpose			Light Material
		Bare	Bolt-on Cutting Edges	Bolt-on Teeth	Bare	Bolt-on Cutting Edges	Bolt-on Teeth	Bolt-on Cutting Edges
Ground Engaging Type								
	Rated bucket capacity (\$)	m ³ yd ³	1.1 1.44	1.1 1.44	1.1 1.44	0.9 1.18	0.95 1.24	0.9 1.18
Struck capacity (\$)	m ³ yd ³	0.9 1.18	0.9 1.18	0.9 1.18	0.75 0.98	0.75 0.98	0.75 0.98	1.25 1.64
	Bucket width	mm ft/in	2060 6'9"	2080 6'10"	2060 6'9"	2060 6'10"	2080 6'9"	2080 6'10"
Dump clearance at full lift and 45° discharge (\$)	mm ft/in	2653 8'8"	2620 8'7"	2583 8'6"	2665 8'9"	2624 8'7"	2586 8'6"	2463 8'1"
	Reach at full lift and 45° discharge (\$)	mm ft/in	757 2'6"	770 2'6"	830 2'9"	737 2'5"	748 2'5"	811 2'8"
Reach at 45° discharge and 2130 mm (7'0") clearance (\$)	mm ft/in	969 3'2"	986 3'3"	1062 3'6"	944 3'1"	957 3'2"	1038 3'5"	1191 3'11"
	Reach with lift arms horizontal and bucket level	mm ft/in	1999 6'7"	2031 6'8"	2101 6'11"	1978 6'6"	2010 6'7"	2080 6'10"
Digging depth (\$)	mm in	85 3.3	101 4.0	85 3.3	94 3.7	110 4.3	94 3.7	101 4.0
	Overall length	mm ft/in	5598 18'4"	5630 18'6"	5699 18'8"	5576 18'4"	5609 18'5"	5678 18'8"
Overall height with bucket at full raise (\$)	mm ft/in	4304 14'1"	4304 14'1"	4304 14'1"	4345 14'3"	4345 14'3"	4345 14'3"	4437 14'7"
	Loader clearance circle with bucket in carry position	mm ft/in	9022 29'7"	9060 29'9"	9008 29'7"	9018 29'7"	9056 29'9"	9004 29'6"
Static tipping load, straight* (\$)	kg lb	4888 10,773	4719 10,400	4828 10,640	4825 10,634	4865 10,725	4959 10,933	4527 9977
	Static tipping load, full turn* (\$)	kg lb	3982 8776	3844 8472	3933 8668	3931 8663	3423 7546	3499 7714
Breakout force (\$)	kN lbf	61 13,712	55 12,362	50 11,239	58 13,037	56 12,587	52 11,688	43 9665
	Operating weight*	kg lb	6311 13,909	6350 13,995	6324 13,938	6455 14,231	6520 14,374	6494 14,317

*Static tipping load and operating weights shown are with implements, ROPS cab, 12.5-20 tires, full fuel tank and 80 kg (176 lb) operator.
NOTE: Specifications and ratings conform to all applicable standards recommended by the Society of Automotive Engineers (SAE). SAE Standards J732 JUN92 and J742 FEB85 govern loader rating, denoted in the text by (\$).

Bucket Type	General Purpose									
	Ground Engaging Type	Pin On			IT Quick Coupler				ISO 23727 Quick Coupler	
		Bolt-on Cutting Edges	Bolt-on Cutting Edges			Bolt-on Cutting Edges				Bolt-on Cutting Edges
Rated capacity	m ³ yd ³	1.3 1.7	1.3 1.7	1.5 2.0	1.2 1.6	1.3 1.7	1.4 1.8	1.5 2.0	1.2 1.6	1.4 1.8
Width: bucket	mm ft/in	2401 7'10"	2320 7'7"	2401 7'10"	2401 7'10"	2320 7'7"	2401 7'10"	2401 7'10"	2401 7'10"	2401 7'10"
Nominal material density, 100% fill factor	kg/m ³ lb/yd ³	1738 2929	1739 2930	1484 2453	1857 3070	1710 2883	1568 2688	1454 2403	1811 2993	1529 2621
Clearance: full lift, 45° dump	mm ft/in	2846 9'4"	2849 9'4"	2792 9'1"	2809 9'2"	2778 9'1"	2747 9'0"	2721 8'11"	2772 9'1"	2709 8'10"
Reach: full lift, 45° dump	mm ft/in	759 2'5"	765 2'6"	811 2'7"	820 2'8"	843 2'9"	867 2'10"	888 2'10"	863 2'9"	909 2'11"
Reach: 2130 mm (7'0") clearance, 45° dump	mm ft/in	1338 4'4"	1346 4'5"	1361 4'5"	1380 4'6"	1385 4'6"	1392 4'6"	1397 4'7"	1403 4'7"	1411 4'7"
Reach: level arm, level bucket	mm ft/in	2026 6'7"	2027 6'7"	2101 6'10"	2092 6'10"	2132 6'11"	2172 7'1"	2207 7'2"	2149 7'0"	2228 7'3"
Dig depth	mm in	116 4.5	116 4.5	116 4.5	117 4.6	117 4.6	116 4.6	116 4.6	117 4.6	117 4.6
Length: overall	mm ft/in	6226 20'5"	6227 20'5"	6301 20'8"	6293 20'7"	6333 20'9"	6373 20'10"	6407 21'0"	6350 20'10"	6429 21'1"
Height: overall	mm ft/in	4534 14'10"	4522 14'10"	4593 15'0"	4563 14'11"	4580 15'0"	4646 15'2"	4653 15'3"	4599 15'1"	4667 15'3"
Turning radius, bucket at carry	mm ft/in	5180 16'11"	5143 16'10"	5202 17'0"	5199 17'0"	5174 16'11"	5223 17'1"	5234 17'2"	5216 17'1"	5239 17'2"
Tipping load — straight, ISO 14397-1*	kg lb	5339 11,767	5339 11,766	5267 11,607	5297 11,674	5284 11,645	5224 11,513	5193 11,444	5170 11,394	5099 11,238
Tipping load — straight, rigid tire**	kg lb	5562 12,257	5561 12,256	5486 12,091	5518 12,160	5504 12,130	5441 11,992	5409 11,921	5385 11,869	5311 11,706
Tipping load — full turn, ISO 14397-1*	kg lb	4518 9958	4520 9963	4451 9810	4458 9825	4447 9801	4390 9676	4362 9613	4346 9578	4281 9434
Tipping load — full turn, rigid tire**	kg lb	4807 10,593	4809 10,598	4735 10,436	4742 10,452	4731 10,427	4671 10,294	4640 10,226	4623 10,189	4554 10,036
Breakout force	kg kN lbf	7327 71.9 16,148	7329 71.9 16,153	6691 65.6 14,747	6741 66.1 14,857	6458 63.3 14,233	6158 60.4 13,572	5936 58.2 13,081	6298 61.8 13,881	5787 56.8 12,754
Operating weight	kg lb	7130 15,718	7110 15,671	7169 15,800	7470 16,463	7466 16,454	7509 16,550	7525 16,585	7492 16,512	7531 16,597

*Full compliance to ISO 14397-1 (2007) Sections 1 thru 6, which requires 2% verification between calculation and testing.

**Compliance to ISO 14397-1 (2007) Sections 1 thru 5.

NOTE: Dimensions listed are for a 910K configured with buckets, bolt-on cutting edges, optional counterweights, additional guarding, 80 kg (176 lb) operator, and Michelin 15.5 R25 (L2) XTLA tires at a pressure of 4.14 bar (60 psi) in the front tires and 2.76 bar (40 psi) in the rear tires.

Bucket Type	General Purpose									
	Ground Engaging Type	Pin On			IT Quick Coupler				ISO 23727	
		Bolt-on Cutting Edges	Bolt-on Cutting Edges			Bolt-on Cutting Edges				Bolt-on Cutting Edges
Rated capacity	m ³ yd ³	1.3 1.7	1.3 1.7	1.5 2.0	1.2 1.6	1.3 1.7	1.4 1.8	1.5 2.0	1.2 1.6	1.4 1.8
Width: bucket	mm ft/in	2401 7'10"	2320 7'7"	2401 7'10"	2401 7'10"	2320 7'7"	2401 7'10"	2401 7'10"	2401 7'10"	2401 7'10"
Nominal material density, 100% fill factor	kg/m ³ lb/yd ³	1614 2719	1616 2723	1380 2281	1719 2841	1584 2670	1453 2491	1348 2229	1682 2780	1422 2438
Clearance: full lift, 45° dump	mm ft/in	3202 10'6"	3205 10'6"	3149 10'3"	3166 10'4"	3135 10'3"	3103 10'2"	3077 10'1"	3128 10'3"	3066 10'0"
Reach: full lift, 45° dump	mm ft/in	978 3'2"	984 3'2"	1030 3'4"	1039 3'4"	1062 3'5"	1086 3'6"	1107 3'7"	1083 3'6"	1128 3'8"
Reach: 2130 mm (7'0") clearance, 45° dump	mm ft/in	1798 5'10"	1806 5'11"	1826 5'11"	1843 6'0"	1852 6'0"	1861 6'1"	1870 6'1"	1869 6'1"	1884 6'2"
Reach: level arm, level bucket	mm ft/in	2441 8'0"	2442 8'0"	2516 8'3"	2507 8'2"	2546 8'4"	2587 8'5"	2621 8'7"	2564 8'4"	2643 8'8"
Dig depth	mm in	294 11.6	294 11.6	294 11.6	295 11.6	295 11.6	295 11.6	295 11.6	295 11.6	295 11.6
Length: overall	mm ft/in	6758 22'2"	6759 22'2"	6834 22'5"	6825 22'4"	6865 22'6"	6905 22'7"	6939 22'9"	6882 22'6"	6961 22'10"
Height: overall	mm ft/in	4891 16'0"	4879 16'0"	4949 16'2"	4920 16'1"	4937 16'2"	5002 16'4"	5009 16'5"	4955 16'3"	5023 16'5"
Turning radius, bucket at carry	mm ft/in	5419 17'9"	5384 17'7"	5443 17'10"	5440 17'10"	5417 17'9"	5465 17'11"	5476 17'11"	5452 17'10"	5478 17'11"
Tipping load — straight, ISO 14397-1*	kg lb	5005 11,031	5008 11,037	4945 10,899	4949 10,907	4942 10,892	4889 10,774	4863 10,718	4849 10,688	4790 10,558
Tipping load — straight, rigid tire**	kg lb	5214 11,490	5217 11,497	5151 11,353	5155 11,362	5148 11,346	5092 11,223	5066 11,165	5051 11,133	4990 10,998
Tipping load — full turn, ISO 14397-1*	kg lb	4195 9246	4201 9258	4139 9123	4125 9091	4120 9079	4069 8967	4045 8914	4037 8897	3982 8776
Tipping load — full turn, rigid tire**	kg lb	4463 9836	4469 9849	4404 9705	4388 9671	4383 9659	4328 9539	4303 9483	4295 9465	4236 9336
Breakout force	kg kN lbf	7392 72.5 16,291	7394 72.5 16,296	6751 66.2 14,879	6800 66.7 14,987	6514 63.9 14,357	6212 60.9 13,692	5988 58.7 13,198	6351 62.3 13,998	5836 57.2 12,862
Operating weight	kg lb	7639 16,837	7620 16,793	7678 16,922	7979 17,586	7975 17,576	8019 17,673	8035 17,708	8002 17,635	8040 17,720

*Full compliance to ISO 14397-1 (2007) Sections 1 thru 6, which requires 2% verification between calculation and testing.

**Compliance to ISO 14397-1 (2007) Sections 1 thru 5.

NOTE: Dimensions listed are for a 910K configured with buckets, bolt-on cutting edges, optional counterweights, additional guarding, 80 kg (176 lb) operator, and Michelin 15.5 R25 (L2) XTLA tires at a pressure of 4.14 bar (60 psi) in the front tires and 2.76 bar (40 psi) in the rear tires.

Performance Data
 ● 910K
 ● Pallet Forks
 ● Material Handling Arm

Wheel Loaders
 Integrated Toolcarriers

		Pallet Forks — Standard Lift IT	Pallet Forks — High Lift IT
Fork tine length	mm	1200	1200
	ft/in	3'11"	3'11"
Load center	mm	600	600
	ft/in	1'11"	1'11"
Overall length	mm	6719	7259
	ft/in	22'0"	23'9"
Ground reach	mm	693	1233
	ft/in	2'3"	4'0"
Digging depth	mm	78	256
	in	3.1	10.1
Level arm reach	mm	1354	1769
	ft/in	4'5"	5'9"
Full lift reach	mm	502	722
	ft/in	1'7"	2'4"
Level arm clearance	mm	1640	1640
	ft/in	5'4"	5'4"
Full lift clearance	mm	3457	3813
	ft/in	11'4"	12'6"
Overall height	mm	4443	4800
	ft/in	14'6"	15'8"
Tipping load — straight (ISO 14397-1)*	kg	4097	3943
	lb	9028	8690
Tipping load — full turn (ISO 14397-1)*	kg	3456	3295
	lb	7615	7261
Operating weight	kg	7368	7877
	lb	16,238	17,361
Rated load (% of full turn tip): 50% of tip (SAE J1197)**	kg	1728	1647
	lb	3807	3630
Rated load (% of full turn tip): 60% of tip — rough terrain (EN474-3)**	kg	2073	1977
	lb	4569	4356
Rated load (% of full turn tip): 80% of tip — firm and level (EN474-3)**	kg	2764	2636
	lb	6092	5809
Minimum fork spacing	mm	300	300
	in	11	11
Carriage width	mm	1550	1550
	ft/in	5'1"	5'1"
Maximum fork spacing	mm	1526	1526
	ft/in	5'0"	5'0"

*Full compliance to ISO 14397-1 (2007) Sections 1 thru 6, which requires 2% verification between calculation and testing.

**Full compliance to EN474-3 and SAE J1197.

NOTE: Dimensions listed are for a machine configured with IT work tools, 80 kg (176 lb) operator, and standard tires.

Handling Arm Position		Material Handling Arm — Standard Lift			Material Handling Arm — High Lift		
		Retracted	Mid-position	Extended	Retracted	Mid-position	Extended
Rated load (50% of full turn tip* SAE J1197)	kg	1153	901	741	1153	922	769
	lb	2540	1986	1634	2541	2031	1695
Operating weight	kg	7336	7336	7336	7846	7846	7846
	lb	16,169	16,169	16,169	17,292	17,292	17,292

*Full compliance to EN474-3 and SAE J1197.

Bucket Type	General Purpose									
	Ground Engaging Type	Pin On			IT Quick Coupler				ISO 23727 Quick Coupler	
			Bolt-on Cutting Edges			Bolt-on Cutting Edges				Bolt-on Cutting Edges
Rated capacity	m ³ yd ³	1.3 1.7	1.3 1.7	1.5 2.0	1.2 1.6	1.3 1.7	1.4 1.8	1.5 2.0	1.2 1.6	1.4 1.8
Width: bucket	mm ft/in	2401 7'10"	2320 7'7"	2401 7'10"	2401 7'10"	2320 7'7"	2401 7'10"	2401 7'10"	2401 7'10"	2401 7'10"
Nominal material density, 100% fill factor	kg/m ³ lb/yd ³	2145 3616	2145 3615	1835 3033	2282 3772	2101 3541	1930 3308	1790 2959	2228 3683	1884 3229
Clearance: full lift, 45° dump	mm ft/in	2874 9'5"	2877 9'5"	2820 9'3"	2838 9'3"	2806 9'2"	2775 9'1"	2749 9'0"	2800 9'2"	2738 8'11"
Reach: full lift, 45° dump	mm ft/in	737 2'5"	744 2'5"	790 2'7"	799 2'7"	822 2'8"	847 2'9"	868 2'10"	843 2'9"	889 2'10"
Reach: 2130 mm (7'0") clearance, 45° dump	mm ft/in	1327 4'4"	1335 4'4"	1352 4'5"	1370 4'5"	1377 4'6"	1384 4'6"	1390 4'6"	1394 4'6"	1404 4'7"
Reach: level arm, level bucket	mm ft/in	1996 6'6"	1998 6'6"	2072 6'9"	2063 6'9"	2102 6'10"	2143 7'0"	2177 7'1"	2120 6'11"	2199 7'2"
Dig depth	mm in	89 3.5	89 3.5	89 3.5	90 3.5	90 3.5	89 3.5	89 3.5	90 3.5	90 3.5
Length: overall	mm ft/in	6215 20'4"	6216 20'4"	6291 20'7"	6282 20'7"	6322 20'8"	6362 20'10"	6397 20'11"	6340 20'9"	6419 21'0"
Height: overall	mm ft/in	4562 14'11"	4551 14'11"	4621 15'1"	4591 15'0"	4608 15'1"	4674 15'4"	4681 15'4"	4627 15'2"	4695 15'4"
Turning radius, bucket at carry	mm ft/in	5178 16'11"	5141 16'10"	5200 17'0"	5198 17'0"	5172 16'11"	5222 17'1"	5232 17'2"	5216 17'1"	5240 17'2"
Tipping load — straight, ISO 14397-1*	kg lb	6599 14,544	6594 14,533	6518 14,364	6508 14,343	6491 14,305	6426 14,163	6391 14,086	6360 14,016	6281 13,842
Tipping load — straight, rigid tire**	kg lb	6874 15,150	6869 15,139	6789 14,963	6779 14,940	6761 14,901	6694 14,753	6658 14,673	6625 14,600	6542 14,419
Tipping load — full turn, ISO 14397-1*	kg lb	5578 12,294	5577 12,291	5504 12,130	5477 12,071	5463 12,040	5403 11,907	5371 11,837	5348 11,786	5275 11,626
Tipping load — full turn, rigid tire**	kg lb	5934 13,079	5933 13,075	5855 12,904	5827 12,842	5812 12,809	5748 12,667	5714 12,593	5689 12,538	5612 12,369
Breakout force	kg kN lbf	8730 85.6 19,241	8731 85.6 19,242	7981 78.3 17,589	8045 78.9 17,730	7708 75.6 16,987	7357 72.1 16,214	7095 69.6 15,636	7527 73.8 16,589	6924 67.9 15,259
Operating weight	kg lb	8088 17,825	8068 17,781	8126 17,910	8427 18,573	8423 18,564	8467 18,663	8483 18,695	8450 18,623	8488 18,708

*Full compliance to ISO 14397-1 (2007) Sections 1 thru 6, which requires 2% verification between calculation and testing.

**Compliance to ISO 14397-1 (2007) Sections 1 thru 5.

NOTE: Dimensions listed are for a 914K configured with buckets, bolt-on cutting edges, optional counterweights, additional guarding, 80 kg (176 lb) operator, and Michelin 17.5 R25 (L2) XTLA tires at a pressure of 4.14 bar (60 psi) in the front tires and 2.76 bar (40 psi) in the rear tires.

Bucket Type	General Purpose									
	Ground Engaging Type	Pin On			IT Quick Coupler				ISO 23727 Quick Coupler	
		Bolt-on Cutting Edges	Bolt-on Cutting Edges			Bolt-on Cutting Edges				Bolt-on Cutting Edges
Rated capacity	m ³ yd ³	1.3 1.7	1.3 1.7	1.5 2.0	1.2 1.6	1.3 1.7	1.4 1.8	1.5 2.0	1.2 1.6	1.4 1.8
Width: bucket	mm ft/in	2401 7'10"	2320 7'7"	2401 7'10"	2401 7'10"	2320 7'7"	2401 7'10"	2401 7'10"	2401 7'10"	2401 7'10"
Nominal material density, 100% fill factor	kg/m ³ lb/yd ³	1719 2897	1721 2900	1471 2431	1829 3023	1686 2841	1547 2652	1436 2373	1791 2960	1515 2596
Clearance: full lift, 45° dump	mm ft/in	3227 10'7"	3230 10'7"	3174 10'4"	3191 10'5"	3160 10'4"	3129 10'3"	3103 10'2"	3153 10'4"	3091 10'1"
Reach: full lift, 45° dump	mm ft/in	956 3'1"	963 3'1"	1009 3'3"	1018 3'4"	1041 3'4"	1066 3'5"	1088 3'6"	1062 3'5"	1108 3'7"
Reach: 2130 mm (7'0") clearance, 45° dump	mm ft/in	1782 5'10"	1790 5'10"	1812 5'11"	1829 5'11"	1838 6'0"	1848 6'0"	1857 6'1"	1856 6'1"	1872 6'1"
Reach: level arm, level bucket	mm ft/in	2411 7'10"	2412 7'10"	2487 8'1"	2477 8'1"	2517 8'3"	2558 8'4"	2592 8'6"	2535 8'3"	2614 8'6"
Dig depth	mm in	272 10.7	272 10.7	272 10.7	274 10.8	274 10.8	273 10.8	273 10.8	273 10.8	273 10.8
Length: overall	mm ft/in	6758 22'2"	6760 22'2"	6834 22'5"	6825 22'4"	6865 22'6"	6905 22'7"	6940 22'9"	6883 22'6"	6962 22'10"
Height: overall	mm ft/in	4916 16'1"	4904 16'1"	4974 16'3"	4945 16'2"	4962 16'3"	5027 16'5"	5034 16'6"	4980 16'4"	5048 16'6"
Turning radius, bucket at carry	mm ft/in	5424 17'9"	5389 17'8"	5448 17'10"	5445 17'10"	5422 17'9"	5471 17'11"	5482 17'11"	5458 17'10"	5484 17'11"
Tipping load — straight, ISO 14397-1*	kg lb	5317 11,717	5319 11,722	5254 11,580	5250 11,571	5242 11,553	5187 11,433	5161 11,374	5146 11,341	5085 11,206
Tipping load — straight, rigid tire**	kg lb	5538 12,205	5540 12,211	5473 12,063	5469 12,053	5461 12,035	5404 11,909	5376 11,848	5360 11,813	5297 11,673
Tipping load — full turn, ISO 14397-1*	kg lb	4469 9850	4474 9860	4412 9722	4390 9675	4384 9661	4332 9546	4307 9492	4298 9472	4241 9347
Tipping load — full turn, rigid tire**	kg lb	4755 10,479	4760 10,490	4693 10,343	4670 10,293	4663 10,278	4608 10,156	4582 10,098	4572 10,077	4512 9943
Breakout force	kg kN lbf	8861 86.9 19,528	8861 86.9 19,528	8100 79.4 17,853	8164 80.1 17,993	7822 76.7 17,239	7466 73.2 16,456	7201 70.6 15,870	7635 74.9 16,827	7024 68.9 15,481
Operating weight	kg lb	8142 17,944	8122 17,901	8181 18,030	8482 18,693	8477 18,684	8521 18,785	8537 18,815	8504 18,742	8542 18,827

*Full compliance to ISO 14397-1 (2007) Sections 1 thru 6, which requires 2% verification between calculation and testing.

**Compliance to ISO 14397-1 (2007) Sections 1 thru 5.

NOTE: Dimensions listed are for a 914K configured with buckets, bolt-on cutting edges, optional counterweights, additional guarding, 80 kg (176 lb) operator, and Michelin 17.5 R25 (L2) XTLA tires at a pressure of 4.14 bar (60 psi) in the front tires and 2.76 bar (40 psi) in the rear tires.

Wheel Loaders Integrated Toolcarriers

Performance Data

- 914K
- Pallet Forks
- Material Handling Arm

		Pallet Forks — Standard Lift IT		Pallet Forks — High Lift IT	
Fork tine length	mm	1200		1200	
	ft/in	3'11"		3'11"	
Load center	mm	600		600	
	ft/in	1'11"		1'11"	
Overall length	mm	6706		7259	
	ft/in	22'0"		23'9"	
Ground reach	mm	637		1189	
	ft/in	2'1"		3'10"	
Digging depth	mm	51		235	
	in	2		9.2	
Level arm reach	mm	1324		1739	
	ft/in	4'4"		5'8"	
Full lift reach	mm	472		691	
	ft/in	1'6"		2'3"	
Level arm clearance	mm	1689		1689	
	ft/in	5'6"		5'6"	
Full lift clearance	mm	3485		3838	
	ft/in	11'5"		12'7"	
Overall height	mm	4472		4825	
	ft/in	14'8"		15'9"	
Tipping load — straight (ISO 14397-1)*	kg	5051		4200	
	lb	11,131		9257	
Tipping load — full turn (ISO 14397-1)*	kg	4259		3521	
	lb	9386		7759	
Operating weight	kg	8326		8380	
	lb	18,349		18,468	
Rated load (% of full turn tip): 50% of tip (SAE J1197)**	kg	2129		1760	
	lb	4693		3879	
Rated load (% of full turn tip): 60% of tip — rough terrain (EN474-3)**	kg	2555		2112	
	lb	5632		4655	
Rated load (% of full turn tip): 80% of tip — firm and level (EN474-3)**	kg	3407		2817	
	lb	7509		6207	
Minimum fork spacing	mm	300		300	
	in	11		11	
Carriage width	mm	1550		1550	
	ft/in	5'1"		5'1"	
Maximum fork spacing	mm	1526		1526	
	ft/in	5'0"		5'0"	

*Full compliance to ISO 14397-1 (2007) Sections 1 thru 6, which requires 2% verification between calculation and testing.

**Full compliance to EN474-3 and SAE J1197.

NOTE: Dimensions listed are for a machine configured with IT work tools, 80 kg (176 lb) operator, and standard tires.

Handling Arm Position		Material Handling Arm — Standard Lift			Material Handling Arm — High Lift		
		Retracted	Mid-position	Extended	Retracted	Mid-position	Extended
Rated load (50% of full turn tip* SAE J1197)	kg	1430	1122	925	1236	989	827
	lb	3151	2472	2037	2724	2180	1821
Operating weight	kg	8294	8294	8294	8348	8348	8348
	lb	18,280	18,280	18,280	18,399	18,399	18,399

*Full compliance to EN474-3 and SAE J1197.

Bucket Type	General Purpose									
		Bolt-on Cutting Edges			Bolt-on Teeth & Segments			Bolt-on Teeth		
Ground Engaging Type										
Rated bucket capacity	m ³	1.90	2.10	2.30	1.90	2.10	2.30	1.80	2.00	2.20
	yd ³	2.49	2.75	3.01	2.49	2.75	3.01	2.35	2.62	2.88
Struck capacity	m ³	1.70	1.90	2.10	1.70	1.90	2.10	1.60	1.80	2.00
	yd ³	2.22	2.49	2.75	2.22	2.49	2.75	2.09	2.35	2.62
Bucket width	mm	2550	2550	2550	2550	2550	2550	2550	2550	2550
	ft/in	8'4"	8'4"	8'4"	8'4"	8'4"	8'4"	8'4"	8'4"	8'4"
Dump clearance at full lift and 45° discharge	mm	2912	2855	2807	2809	2751	2702	2809	2751	2702
	ft/in	9'7"	9'4"	9'3"	9'3"	9'0"	8'10"	9'3"	9'0"	8'10"
Reach at full lift and 45° discharge	mm	992	1033	1070	1097	1135	1172	1097	1135	1172
	ft/in	3'3"	3'5"	3'6"	3'7"	3'9"	3'10"	3'7"	3'9"	3'10"
Reach at 45° discharge and 2130 mm (7'0") clearance	mm	1547	1560	1573	1600	1608	1617	1600	1608	1617
	ft/in	5'1"	5'1"	5'2"	5'3"	5'3"	5'4"	5'3"	5'3"	5'4"
Reach with lift arms horizontal and bucket level	mm	2278	2350	2413	2424	2496	2559	2424	2496	2559
	ft/in	7'6"	7'9"	7'11"	7'11"	8'2"	8'5"	7'11"	8'2"	8'5"
Digging depth	mm	100	100	100	111	111	111	111	111	111
	in	3.9	3.9	3.9	4.4	4.4	4.4	4.4	4.4	4.4
Overall length	mm	7409	7481	7544	7555	7627	7690	7535	7607	7670
	ft/in	24'4"	24'7"	24'9"	24'9"	25'0"	25'3"	24'9"	24'11"	25'2"
Overall height with bucket at full raise	mm	5052	5122	5180	5052	5122	5180	5052	5122	5180
	ft/in	16'7"	16'10"	17'0"	16'7"	16'10"	17'0"	16'7"	16'10"	17'0"
Loader clearance radius with bucket in carry position	mm	5912	5933	5951	5958	5980	5999	5958	5980	5999
	ft/in	19'5"	19'6"	19'6"	19'7"	19'7"	19'8"	19'7"	19'7"	19'8"
Static tipping load straight	kg	9179	9115	9008	9031	8965	8857	9132	9067	8961
	lb	20,236	20,095	19,859	19,910	19,764	19,526	20,133	19,989	19,756
Static tipping load with 40° turn	kg	7894	7836	7737	7750	7690	7589	7848	7790	7690
	lb	17,403	17,275	17,057	17,086	16,954	16,731	17,302	17,174	16,954
Breakout force	kg	10 685	9956	9388	10 565	9835	9268	11 400	10 569	9928
	lb	23,557	21,949	20,697	23,292	21,683	20,433	25,133	23,301	21,888
Operating weight	kg	12 696	12 715	12 778	12 816	12 835	12 899	12 734	12 753	12 817
	lb	27,990	28,032	28,171	28,254	28,296	28,437	28,074	28,116	28,257

*Meets Tier 4 Final/Stage IV/Japan 2014 (Tier 4 Final) emission standards.

NOTE: Specifications and ratings conform to all applicable standards recommended by the Society of Automotive Engineers (SAE), including SAE Standards J732 (APR07) which governs loader ratings.

Wheel Loaders Integrated Toolcarriers

Performance Data ● 926M* Standard Lift Pin On Bucket

Bucket Type		Light Material								
		Bolt-on Cutting Edges			Bolt-on Teeth & Segments			Bolt-on Teeth		
Ground Engaging Type										
Rated bucket capacity	m ³	3.50	4.20	5.00	3.50	4.20	5.00	3.40	4.10	4.90
	yd ³	4.58	5.49	6.54	4.58	5.49	6.54	4.45	5.36	6.41
Struck capacity	m ³	3.30	4.00	4.80	3.30	4.00	4.80	3.20	3.90	4.70
	yd ³	4.32	5.23	6.28	4.32	5.23	6.28	4.19	5.10	6.15
Bucket width	mm	2750	2750	2750	2750	2750	2750	2750	2750	2750
	ft/in	9'0"	9'0"	9'0"	9'0"	9'0"	9'0"	9'0"	9'0"	9'0"
Dump clearance at full lift and 45° discharge	mm	2629	2509	2509	2518	2398	2398	2518	2398	2398
	ft/in	8'8"	8'3"	8'3"	8'3"	7'10"	7'10"	8'3"	7'10"	7'10"
Reach at full lift and 45° discharge	mm	1137	1257	1257	1232	1352	1352	1232	1352	1352
	ft/in	3'9"	4'1"	4'1"	4'1"	4'5"	4'5"	4'1"	4'5"	4'5"
Reach at 45° discharge and 2130 mm (7'0") clearance	mm	1538	1579	1579	1560	1592	1592	1560	1592	1592
	ft/in	5'1"	5'2"	5'2"	5'1"	5'3"	5'3"	5'1"	5'3"	5'3"
Reach with lift arms horizontal and bucket level	mm	2603	2773	2773	2749	2919	2919	2749	2919	2919
	ft/in	8'6"	9'1"	9'1"	9'0"	9'7"	9'7"	9'0"	9'7"	9'7"
Digging depth	mm	100	100	100	111	111	111	111	111	111
	in	3.9	3.9	3.9	4.4	4.4	4.4	4.4	4.4	4.4
Overall length	mm	7734	7904	7904	7880	8050	8050	7860	8030	8030
	ft/in	25'4"	25'11"	25'11"	25'10"	26'5"	26'5"	25'9"	26'4"	26'4"
Overall height with bucket at full raise	mm	5284	5445	5725	5284	5445	5725	5284	5445	5725
	ft/in	17'4"	17'10"	18'9"	17'4"	17'10"	18'9"	17'4"	17'10"	18'9"
Loader clearance radius with bucket in carry position	mm	6099	6152	6152	6148	6202	6202	6148	6202	6202
	ft/in	20'0"	20'2"	20'2"	20'2"	20'4"	20'4"	20'2"	20'4"	20'4"
Static tipping load straight	kg	8566	8300	8260	8423	8154	8114	8529	8262	8222
	lb	18,885	18,298	18,210	18,570	17,976	17,888	18,803	18,215	18,126
Static tipping load with 40° turn	kg	7321	7076	7035	7181	6933	6892	7285	7039	6998
	lb	16,140	15,600	15,510	15,831	15,285	15,194	16,061	15,518	15,428
Breakout force	kg	7888	6893	6842	7777	6782	6731	8271	7181	7127
	lb	17,390	15,197	15,084	17,145	14,952	14,839	18,235	15,831	15,712
Operating weight	kg	13 092	13 222	13 302	13 203	13 333	13 413	13 121	13 250	13 330
	lb	28,863	29,149	29,326	29,108	29,394	29,571	28,927	29,211	29,388

*Meets Tier 4 Final/Stage IV/Japan 2014 (Tier 4 Final) emission standards.

NOTE: Specifications and ratings conform to all applicable standards recommended by the Society of Automotive Engineers (SAE), including SAE Standards J732 (APR07) which governs loader ratings.

	Change in Operating Weight		Change in Articulated Static Tipping Load	
	kg	lb	kg	lb
Without Ride Control System	- 31	- 68	- 14	- 31
Without Guard, driveshaft	- 43	- 95	- 16	- 36
With Guard, windshield	41	90	24	53
Without Rooding Fenders	- 41	- 90	- 31	- 69
Without Secondary Steering	- 53	- 117	- 54	- 119
Without Guard, crankcase	- 11	- 24	- 15	- 34
Without Guard, power train	- 67	- 148	- 65	- 144
With Guard, power train side	11	24	10	22
With Counterweight, Logger	298	656	417	919
With Cold Start 120V	54	119	93	206
With Product Link™	8	18	8	18
Tires, 1-piece rims				
17.5-25, 12PR (L-2)	- 680	- 1499	- 832	- 1834
17.5-25, 12PR (L-3)	- 663	- 1462	- 812	- 1790
17.5-25, Radial (L-2) VUT	- 437	- 963	- 536	- 1182
17.5-25, Radial (L-3) VMT	- 377	- 831	- 462	- 1019
Tires, 3-piece rims				
17.5-25, 12PR (L-2)	- 629	- 1387	- 770	- 1698
17.5-25, 12PR (L-3)	- 612	- 1349	- 750	- 1653
17.5-25, Radial (L-2) VUT	- 386	- 851	- 473	- 1043
17.5-25, Radial (L-3) VMT	- 326	- 719	- 400	- 882
550/65 R25, Radial (L-3)	- 108	- 238	- 132	- 291
600/65 R25, Radial (L-3)	24	53	29	64
20.5-25, 12PR (L-2)	- 334	- 736	- 409	- 902
20.5-25, 12PR (L-3)	- 263	- 580	- 322	- 710
20.5 R25, Radial (L-5) XMINE D2	616	1358	755	1664
20.5 R25, Radial (L-2) VUT	- 232	- 511	- 284	- 626
20.5 R25, Radial (L-3) VMT	56	123	69	152

*Meets Tier 4 Final/Stage IV/Japan 2014 (Tier 4 Final) emission standards.

Wheel Loaders Integrated Toolcarriers

Performance Data ● 926M* High Lift Pin On Bucket

Bucket Type		General Purpose								
		Bolt-on Cutting Edges			Bolt-on Teeth & Segments			Bolt-on Teeth		
Ground Engaging Type										
Rated bucket capacity	m ³	1.90	2.10	2.30	1.90	2.10	2.30	1.80	2.00	2.20
	yd ³	2.49	2.75	3.01	2.49	2.75	3.01	2.35	2.62	2.88
Struck capacity	m ³	1.70	1.90	2.10	1.70	1.90	2.10	1.60	1.80	2.00
	yd ³	2.22	2.49	2.75	2.22	2.49	2.75	2.09	2.35	2.62
Bucket width	mm	2550	2550	2550	2550	2550	2550	2550	2550	2550
	ft/in	8'4"	8'4"	8'4"	8'4"	8'4"	8'4"	8'4"	8'4"	8'4"
Dump clearance at full lift and 45° discharge	mm	3405	3348	3300	3302	3244	3195	3302	3244	3195
	ft/in	11'2"	11'0"	10'10"	10'10"	10'8"	10'6"	10'10"	10'8"	10'6"
Reach at full lift and 45° discharge	mm	1229	1269	1307	1333	1372	1409	1333	1372	1409
	ft/in	4'0"	4'2"	4'3"	4'4"	4'6"	4'7"	4'4"	4'6"	4'7"
Reach at 45° discharge and 2130 mm (7'0") clearance	mm	2113	2132	2150	2177	2191	2206	2177	2191	2206
	ft/in	6'11"	7'0"	7'1"	7'2"	7'2"	7'3"	7'2"	7'2"	7'3"
Reach with lift arms horizontal and bucket level	mm	2801	2873	2936	2947	3019	3082	2947	3019	3082
	ft/in	9'2"	9'5"	9'8"	9'8"	9'11"	10'1"	9'8"	9'11"	10'1"
Digging depth	mm	135	135	135	146	146	146	146	146	146
	in	5.3	5.3	5.3	5.7	5.7	5.7	5.7	5.7	5.7
Overall length	mm	8051	8123	8186	8197	8269	8332	8181	8253	8316
	ft/in	26'5"	26'8"	26'10"	26'11"	27'2"	27'4"	26'10"	27'1"	27'3"
Overall height with bucket at full raise	mm	5545	5615	5673	5545	5615	5673	5545	5615	5673
	ft/in	18'2"	18'5"	18'7"	18'2"	18'5"	18'7"	18'2"	18'5"	18'7"
Loader clearance radius with bucket in carry position	mm	6220	6244	6265	6273	6297	6319	6273	6297	6319
	ft/in	20'5"	20'6"	20'7"	20'7"	20'8"	20'9"	20'7"	20'8"	20'9"
Static tipping load straight	kg	6993	6944	6852	6851	6801	6708	6948	6898	6807
	lb	15,417	15,309	15,106	15,104	14,994	14,789	15,318	15,207	15,007
Static tipping load with 40° turn	kg	5970	5925	5839	5831	5785	5698	5926	5881	5794
	lb	13,162	13,062	12,873	12,855	12,754	12,562	13,065	12,965	12,774
Breakout force	kg	10 157	9462	8920	10 037	9341	8799	10 827	10 036	9425
	lb	22,392	20,860	19,665	22,128	20,593	19,399	23,870	22,126	20,779
Operating weight	kg	12 974	12 993	13 057	13 095	13 114	13 177	13 012	13 031	13 095
	lb	28,603	28,645	28,786	28,869	28,911	29,050	28,687	28,728	28,869

*Meets Tier 4 Final/Stage IV/Japan 2014 (Tier 4 Final) emission standards.

NOTE: Specifications and ratings conform to all applicable standards recommended by the Society of Automotive Engineers (SAE), including SAE Standards J732 (APR07) which governs loader ratings.

Bucket Type		Light Material								
		Bolt-on Cutting Edges			Bolt-on Teeth & Segments			Bolt-on Teeth		
Ground Engaging Type										
Rated bucket capacity	m ³	3.50	4.20	5.00	3.50	4.20	5.00	3.40	4.10	4.90
	yd ³	4.58	5.49	6.54	4.58	5.49	6.54	4.45	5.36	6.41
Struck capacity	m ³	3.30	4.00	4.80	3.30	4.00	4.80	3.20	3.90	4.70
	yd ³	4.32	5.23	6.28	4.32	5.23	6.28	4.19	5.10	6.15
Bucket width	mm	2750	2750	2750	2750	2750	2750	2750	2750	2750
	ft/in	9'0"	9'0"	9'0"	9'0"	9'0"	9'0"	9'0"	9'0"	9'0"
Dump clearance at full lift and 45° discharge	mm	3122	3002	3002	3011	2891	2891	3011	2891	2891
	ft/in	10'3"	9'10"	9'10"	9'11"	9'6"	9'6"	9'11"	9'6"	9'6"
Reach at full lift and 45° discharge	mm	1373	1493	1493	1468	1589	1589	1468	1589	1589
	ft/in	4'6"	4'11"	4'11"	4'10"	5'3"	5'3"	4'10"	5'3"	5'3"
Reach at 45° discharge and 2130 mm (7'0") clearance	mm	2135	2193	2193	2173	2225	2225	2173	2225	2225
	ft/in	7'0"	7'2"	7'2"	7'2"	7'4"	7'4"	7'2"	7'4"	7'4"
Reach with lift arms horizontal and bucket level	mm	3126	3296	3296	3272	3442	3442	3272	3442	3442
	ft/in	10'3"	10'10"	10'10"	10'9"	11'4"	11'4"	10'9"	11'4"	11'4"
Digging depth	mm	135	135	135	146	146	146	146	146	146
	in	5.3	5.3	5.3	5.7	5.7	5.7	5.7	5.7	5.7
Overall length	mm	8376	8546	8546	8522	8692	8692	8506	8676	8676
	ft/in	27'6"	28'0"	28'0"	28'0"	28'6"	28'6"	27'11"	28'6"	28'6"
Overall height with bucket at full raise	mm	5777	5938	6218	5777	5938	6218	5777	5938	6218
	ft/in	18'11"	19'6"	20'5"	18'11"	19'6"	20'5"	18'11"	19'6"	20'5"
Loader clearance radius with bucket in carry position	mm	6415	6474	6474	6470	6530	6530	6470	6530	6530
	ft/in	21'1"	21'3"	21'3"	21'3"	21'5"	21'5"	21'3"	21'5"	21'5"
Static tipping load straight	kg	6459	6241	6187	6323	6103	6049	6424	6205	6152
	lb	14,240	13,759	13,640	13,940	13,455	13,336	14,162	13,680	13,563
Static tipping load with 40° turn	kg	5465	5263	5209	5332	5127	5074	5431	5228	5174
	lb	12,048	11,603	11,484	11,755	11,303	11,186	11,973	11,526	11,407
Breakout force	kg	7484	6534	6483	7373	6422	6372	7841	6800	6746
	lb	16,499	14,405	14,293	16,255	14,158	14,048	17,287	14,992	14,872
Operating weight	kg	13 370	13 500	13 580	13 481	13 611	13 691	13 399	13 529	13 609
	lb	29,476	29,762	29,939	29,720	30,007	30,183	29,540	29,826	30,003

*Meets Tier 4 Final/Stage IV/Japan 2014 (Tier 4 Final) emission standards.

NOTE: Specifications and ratings conform to all applicable standards recommended by the Society of Automotive Engineers (SAE), including SAE Standards J732 (APR07) which governs loader ratings.

	Change in Operating Weight		Change in Articulated Static Tipping Load	
	kg	lb	kg	lb
Without Ride Control System	- 31	- 68	- 11	- 25
Without Guard, driveshaft	- 43	- 95	- 13	- 29
With Guard, windshield	41	90	19	42
Without Rooding Fenders	- 41	- 90	- 25	- 55
Without Secondary Steering	- 53	- 117	- 43	- 95
Without Guard, crankcase	- 11	- 24	- 12	- 27
Without Guard, power train	- 67	- 148	- 52	- 115
With Guard, power train side	11	24	8	18
With Toolbox Gp	34	75	23	51
With Cold Start 120V	54	119	75	165
With Product Link	8	18	6	14
Tires, 1-piece rims				
17.5-25, 12PR (L-2)	- 680	- 1499	- 668	- 1473
17.5-25, 12PR (L-3)	- 663	- 1462	- 652	- 1437
17.5-25, Radial (L-2) VUT	- 437	- 963	- 430	- 948
17.5-25, Radial (L-3) VMT	- 377	- 831	- 371	- 818
Tires, 3-piece rims				
17.5-25, 12PR (L-2)	- 629	- 1387	- 618	- 1362
17.5-25, 12PR (L-3)	- 612	- 1349	- 602	- 1327
17.5-25, Radial (L-2) VUT	- 386	- 851	- 380	- 838
17.5-25, Radial (L-3) VMT	- 326	- 719	- 321	- 708
550/65 R25, Radial (L-3)	- 108	- 238	- 106	- 234
600/65 R25, Radial (L-3)	24	53	24	53
20.5-25, 12PR (L-2)	- 334	- 736	- 328	- 723
20.5-25, 12PR (L-3)	- 263	- 580	- 258	- 569
20.5 R25, Radial (L-5) XMINE D2	616	1358	605	1334
20.5 R25, Radial (L-2) VUT	- 232	- 511	- 228	- 503
20.5 R25, Radial (L-3) VMT	56	123	55	121

*Meets Tier 4 Final/Stage IV/Japan 2014 (Tier 4 Final) emission standards.

Bucket Type	General Purpose									
	Ground Engaging Type	Bolt-on Cutting Edges			Bolt-on Teeth & Segments			Bolt-on Teeth		
Rated bucket capacity		m ³	1.90	2.10	2.30	1.90	2.10	2.30	1.80	2.00
	yd ³	2.49	2.75	3.01	2.49	2.75	3.01	2.35	2.62	2.88
Struck capacity	m ³	1.70	1.90	2.10	1.70	1.90	2.10	1.60	1.80	2.00
	yd ³	2.22	2.49	2.75	2.22	2.49	2.75	2.09	2.35	2.62
Bucket width	mm	2550	2550	2550	2550	2550	2550	2550	2550	2550
	ft/in	8'4"	8'4"	8'4"	8'4"	8'4"	8'4"	8'4"	8'4"	8'4"
Dump clearance at full lift and 45° discharge	mm	2885	2828	2779	2782	2723	2674	2782	2723	2674
	ft/in	9'6"	9'3"	9'1"	9'2"	8'11"	8'9"	9'2"	8'11"	8'9"
Reach at full lift and 45° discharge	mm	1024	1064	1102	1129	1167	1204	1129	1167	1204
	ft/in	3'4"	3'6"	3'7"	3'8"	3'10"	3'11"	3'8"	3'10"	3'11"
Reach at 45° discharge and 2130 mm (7'0") clearance	mm	1566	1578	1590	1618	1624	1632	1618	1624	1632
	ft/in	5'2"	5'2"	5'3"	5'4"	5'4"	5'4"	5'4"	5'4"	5'4"
Reach with lift arms horizontal and bucket level	mm	2320	2392	2455	2466	2538	2601	2466	2538	2601
	ft/in	7'7"	7'10"	8'1"	8'1"	8'4"	8'6"	8'1"	8'4"	8'6"
Digging depth	mm	100	100	100	111	111	111	111	111	111
	in	3.9	3.9	3.9	4.4	4.4	4.4	4.4	4.4	4.4
Overall length	mm	7451	7523	7586	7597	7669	7732	7576	7648	7711
	ft/in	24'5"	24'8"	24'11"	24'11"	25'2"	25'4"	24'10"	25'1"	25'4"
Overall height with bucket at full raise	mm	5076	5147	5205	5076	5147	5205	5076	5147	5205
	ft/in	16'8"	16'11"	17'1"	16'8"	16'11"	17'1"	16'8"	16'11"	17'1"
Loader clearance radius with bucket in carry position	mm	5924	5945	5964	5971	5993	6012	5971	5993	6012
	ft/in	19'5"	19'6"	19'7"	19'7"	19'8"	19'9"	19'7"	19'8"	19'9"
Static tipping load straight	kg	8786	8701	8621	8639	8552	8470	8740	8654	8573
	lb	19,370	19,182	19,006	19,046	18,854	18,673	19,268	19,079	18,900
Static tipping load with 40° turn	kg	7524	7445	7371	7380	7299	7224	7478	7399	7325
	lb	16,588	16,413	16,250	16,270	16,092	15,926	16,486	16,312	16,149
Breakout force	kg	10 223	9547	9019	10 102	9426	8898	10 874	10 108	9514
	lb	22,538	21,048	19,884	22,271	20,781	19,617	23,973	22,284	20,975
Operating weight	kg	13 050	13 094	13 132	13 171	13 215	13 252	13 088	13 132	13 170
	lb	28,770	28,867	28,951	29,037	29,134	29,216	28,854	28,951	29,035

*Meets Tier 4 Final/Stage IV/Japan 2014 (Tier 4 Final) emission standards.

NOTE: Specifications and ratings conform to all applicable standards recommended by the Society of Automotive Engineers (SAE), including SAE Standards J732 (APR07) which governs loader ratings.

Wheel Loaders Integrated Toolcarriers

Performance Data ● 926M* Standard Lift Fusion Bucket

Bucket Type	Light Material									
		Bolt-on Cutting Edges			Bolt-on Teeth & Segments			Bolt-on Teeth		
Ground Engaging Type										
Rated bucket capacity	m ³	3.50	4.20	5.00	3.50	4.20	5.00	3.40	4.10	4.90
	yd ³	4.58	5.49	6.54	4.58	5.49	6.54	4.45	5.36	6.41
Struck capacity	m ³	3.30	4.00	4.80	3.30	4.00	4.80	3.20	3.90	4.70
	yd ³	4.32	5.23	6.28	4.32	5.23	6.28	4.19	5.10	6.15
Bucket width	mm	2750	2750	2750	2750	2750	2750	2750	2750	2750
	ft/in	9'0"	9'0"	9'0"	9'0"	9'0"	9'0"	9'0"	9'0"	9'0"
Dump clearance at full lift and 45° discharge	mm	2600	2479	2479	2488	2368	2368	2488	2368	2368
	ft/in	8'6"	8'2"	8'2"	8'2"	7'9"	7'9"	8'2"	7'9"	7'9"
Reach at full lift and 45° discharge	mm	1166	1286	1286	1261	1382	1382	1261	1382	1382
	ft/in	3'10"	4'3"	4'3"	4'2"	4'6"	4'6"	4'2"	4'6"	4'6"
Reach at 45° discharge and 2130 mm (7'0") clearance	mm	1549	1588	1588	1569	1598	1598	1569	1598	1598
	ft/in	5'1"	5'3"	5'3"	5'2"	5'3"	5'3"	5'2"	5'3"	5'3"
Reach with lift arms horizontal and bucket level	mm	2645	2815	2815	2791	2961	2961	2791	2961	2961
	ft/in	8'8"	9'3"	9'3"	9'2"	9'9"	9'9"	9'2"	9'9"	9'9"
Digging depth	mm	100	100	100	111	111	111	111	111	111
	in	3.9	3.9	3.9	4.4	4.4	4.4	4.4	4.4	4.4
Overall length	mm	7776	7946	7946	7922	8092	8092	7902	8072	8072
	ft/in	25'6"	26'1"	26'1"	26'0"	26'7"	26'7"	25'11"	26'6"	26'6"
Overall height with bucket at full raise	mm	5309	5471	5752	5309	5471	5752	5309	5471	5752
	ft/in	17'5"	17'11"	18'10"	17'5"	17'11"	18'10"	17'5"	17'11"	18'10"
Loader clearance radius with bucket in carry position	mm	6112	6166	6166	6162	6217	6217	6162	6217	6217
	ft/in	20'1"	20'3"	20'3"	20'3"	20'5"	20'5"	20'3"	20'5"	20'5"
Static tipping load straight	kg	8181	7921	7882	8038	7776	7736	8144	7884	7844
	lb	18,036	17,463	17,377	17,721	17,143	17,055	17,954	17,381	17,293
Static tipping load with 40° turn	kg	6957	6718	6678	6818	6576	6535	6921	6682	6641
	lb	15,338	14,811	14,722	15,031	14,498	14,407	15,258	14,731	14,641
Breakout force	kg	7603	6660	6611	7492	6549	6500	7958	6927	6877
	lb	16,762	14,683	14,575	16,517	14,438	14,330	17,544	15,272	15,161
Operating weight	kg	13 455	13 585	13 662	13 566	13 696	13 773	13 484	13 613	13 691
	lb	29,663	29,950	30,120	29,908	30,194	30,364	29,727	30,011	30,183

*Meets Tier 4 Final/Stage IV/Japan 2014 (Tier 4 Final) emission standards.

NOTE: Specifications and ratings conform to all applicable standards recommended by the Society of Automotive Engineers (SAE), including SAE Standards J732 (APR07) which governs loader ratings.

	Change in Operating Weight		Change in Articulated Static Tipping Load	
	kg	lb	kg	lb
Without Ride Control System	- 31	- 68	- 14	- 30
Without Guard, driveshaft	- 43	- 95	- 16	- 36
With Guard, windshield	41	90	24	52
Without Rooding Fenders	- 41	- 90	- 31	- 68
Without Secondary Steering	- 53	- 117	- 53	- 117
Without Guard, crankcase	- 11	- 24	- 15	- 34
Without Guard, power train	- 67	- 148	- 64	- 142
With Guard, power train side	11	24	10	22
With Counterweight, Logger	298	656	417	919
With Cold Start 120V	54	119	92	203
With Product Link	8	18	8	18
Tires, 1-piece rims				
17.5-25, 12PR (L-2)	- 680	- 1499	- 822	- 1811
17.5-25, 12PR (L-3)	- 663	- 1462	- 802	- 1768
17.5-25, Radial (L-2) VUT	- 437	- 963	- 529	- 1166
17.5-25, Radial (L-3) VMT	- 377	- 831	- 456	- 1006
Tires, 3-piece rims				
17.5-25, 12PR (L-2)	- 629	- 1387	- 760	- 1675
17.5-25, 12PR (L-3)	- 612	- 1349	- 740	- 1631
17.5-25, Radial (L-2) VUT	- 386	- 851	- 467	- 1030
17.5-25, Radial (L-3) VMT	- 326	- 719	- 395	- 871
550/65 R25, Radial (L-3)	- 108	- 238	- 131	- 289
600/65 R25, Radial (L-3)	24	53	29	64
20.5-25, 12PR (L-2)	- 334	- 736	- 404	- 891
20.5-25, 12PR (L-3)	- 263	- 580	- 318	- 701
20.5 R25, Radial (L-5) XMINE D2	616	1358	745	1642
20.5 R25, Radial (L-2) VUT	- 232	- 511	- 281	- 619
20.5 R25, Radial (L-3) VMT	56	123	68	150

*Meets Tier 4 Final/Stage IV/Japan 2014 (Tier 4 Final) emission standards.

Wheel Loaders Integrated Toolcarriers

Performance Data ● 926M* High Lift Fusion Bucket

Bucket Type		General Purpose								
		Bolt-on Cutting Edges			Bolt-on Teeth & Segments			Bolt-on Teeth		
Ground Engaging Type										
Rated bucket capacity	m ³	1.90	2.10	2.30	1.90	2.10	2.30	1.80	2.00	2.20
	yd ³	2.49	2.75	3.01	2.49	2.75	3.01	2.35	2.62	2.88
Struck capacity	m ³	1.70	1.90	2.10	1.70	1.90	2.10	1.60	1.80	2.00
	yd ³	2.22	2.49	2.75	2.22	2.49	2.75	2.09	2.35	2.62
Bucket width	mm	2550	2550	2550	2550	2550	2550	2550	2550	2550
	ft/in	8'4"	8'4"	8'4"	8'4"	8'4"	8'4"	8'4"	8'4"	8'4"
Dump clearance at full lift and 45° discharge	mm	3378	3321	3272	3275	3216	3167	3275	3216	3167
	ft/in	11'1"	10'11"	10'9"	10'9"	10'7"	10'5"	10'9"	10'7"	10'5"
Reach at full lift and 45° discharge	mm	1261	1301	1339	1365	1404	1440	1365	1404	1440
	ft/in	4'2"	4'3"	4'5"	4'6"	4'7"	4'9"	4'6"	4'7"	4'9"
Reach at 45° discharge and 2130 mm (7'0") clearance	mm	2135	2153	2170	2197	2210	2224	2197	2210	2224
	ft/in	7'0"	7'1"	7'1"	7'2"	7'3"	7'4"	7'2"	7'3"	7'4"
Reach with lift arms horizontal and bucket level	mm	2843	2915	2978	2989	3061	3124	2989	3061	3124
	ft/in	9'4"	9'7"	9'9"	9'10"	10'1"	10'3"	9'10"	10'1"	10'3"
Digging depth	mm	135	135	135	146	146	146	146	146	146
	in	5.3	5.3	5.3	5.7	5.7	5.7	5.7	5.7	5.7
Overall length	mm	8093	8165	8228	8239	8311	8374	8223	8295	8358
	ft/in	26'7"	26'9"	27'0"	27'0"	27'3"	27'6"	27'0"	27'3"	27'5"
Overall height with bucket at full raise	mm	5569	5640	5698	5569	5640	5698	5569	5640	5698
	ft/in	18'3"	18'6"	18'8"	18'3"	18'6"	18'8"	18'3"	18'6"	18'8"
Loader clearance radius with bucket in carry position	mm	6234	6258	6279	6288	6312	6334	6288	6312	6334
	ft/in	20'5"	20'6"	20'7"	20'8"	20'9"	20'9"	20'8"	20'9"	20'9"
Static tipping load straight	kg	6632	6562	6496	6491	6419	6352	6588	6516	6451
	lb	14,621	14,467	14,321	14,310	14,151	14,004	14,524	14,365	14,222
Static tipping load with 40° turn	kg	5626	5560	5499	5488	5421	5358	5583	5516	5455
	lb	12,403	12,258	12,123	12,099	11,951	11,812	12,308	12,161	12,026
Breakout force	kg	9714	9069	8565	9593	8949	8445	10 324	9594	9028
	lb	21,416	19,994	18,883	21,149	19,729	18,618	22,761	21,151	19,903
Operating weight	kg	13 328	13 373	13 410	13 449	13 493	13 531	13 367	13 411	13 448
	lb	29,383	29,482	29,564	29,650	29,747	29,831	29,469	29,566	29,648

*Meets Tier 4 Final/Stage IV/Japan 2014 (Tier 4 Final) emission standards.

NOTE: Specifications and ratings conform to all applicable standards recommended by the Society of Automotive Engineers (SAE), including SAE Standards J732 (APR07) which governs loader ratings.

Bucket Type		Light Material								
		Bolt-on Cutting Edges			Bolt-on Teeth & Segments			Bolt-on Teeth		
Ground Engaging Type										
Rated bucket capacity	m ³	3.50	4.20	5.00	3.50	4.20	5.00	3.40	4.10	4.90
	yd ³	4.58	5.49	6.54	4.58	5.49	6.54	4.45	5.36	6.41
Struck capacity	m ³	3.30	4.00	4.80	3.30	4.00	4.80	3.20	3.90	4.70
	yd ³	4.32	5.23	6.28	4.32	5.23	6.28	4.19	5.10	6.15
Bucket width	mm	2750	2750	2750	2750	2750	2750	2750	2750	2750
	ft/in	9'0"	9'0"	9'0"	9'0"	9'0"	9'0"	9'0"	9'0"	9'0"
Dump clearance at full lift and 45° discharge	mm	3093	2972	2972	2981	2861	2861	2981	2861	2861
	ft/in	10'2"	9'9"	9'9"	9'9"	9'5"	9'5"	9'9"	9'5"	9'5"
Reach at full lift and 45° discharge	mm	1403	1523	1523	1498	1618	1618	1498	1618	1618
	ft/in	4'7"	5'0"	5'0"	4'11"	5'4"	5'4"	4'11"	5'4"	5'4"
Reach at 45° discharge and 2130 mm (7'0") clearance	mm	2150	2207	2207	2186	2236	2236	2186	2236	2236
	ft/in	7'1"	7'3"	7'3"	7'2"	7'4"	7'4"	7'2"	7'4"	7'4"
Reach with lift arms horizontal and bucket level	mm	3168	3338	3338	3314	3484	3484	3314	3484	3484
	ft/in	10'5"	10'11"	10'11"	10'10"	11'5"	11'5"	10'10"	11'5"	11'5"
Digging depth	mm	135	135	135	146	146	146	146	146	146
	in	5.3	5.3	5.3	5.7	5.7	5.7	5.7	5.7	5.7
Overall length	mm	8418	8588	8588	8564	8734	8734	8548	8718	8718
	ft/in	27'7"	28'2"	28'2"	28'1"	28'8"	28'8"	28'1"	28'7"	28'7"
Overall height with bucket at full raise	mm	5802	5964	6245	5802	5964	6245	5802	5964	6245
	ft/in	19'0"	19'7"	20'6"	19'0"	19'7"	20'6"	19'0"	19'7"	20'6"
Loader clearance radius with bucket in carry position	mm	6430	6489	6489	6485	6545	6545	6485	6545	6545
	ft/in	21'1"	21'3"	21'3"	21'3"	21'6"	21'6"	21'3"	21'6"	21'6"
Static tipping load straight	kg	6102	5890	5837	5967	5751	5699	6067	5854	5801
	lb	13,453	12,985	12,868	13,155	12,679	12,564	13,375	12,906	12,789
Static tipping load with 40° turn	kg	5125	4927	4875	4992	4792	4739	5091	4892	4840
	lb	11,299	10,862	10,748	11,005	10,565	10,448	11,224	10,785	10,670
Breakout force	kg	7210	6309	6261	7099	6198	6149	7540	6556	6506
	lb	15,895	13,909	13,803	15,651	13,664	13,556	16,623	14,454	14,343
Operating weight	kg	13 733	13 683	13 940	13 844	13 974	14 051	13 762	13 982	13 969
	lb	30,276	30,166	30,732	30,521	30,807	30,977	30,340	30,825	30,796

*Meets Tier 4 Final/Stage IV/Japan 2014 (Tier 4 Final) emission standards.

NOTE: Specifications and ratings conform to all applicable standards recommended by the Society of Automotive Engineers (SAE), including SAE Standards J732 (APR07) which governs loader ratings.

	Change in Operating Weight		Change in Articulated Static Tipping Load	
	kg	lb	kg	lb
Without Ride Control System	- 31	- 68	- 11	- 24
Without Guard, driveshaft	- 43	- 95	- 13	- 29
With Guard, windshield	41	90	19	42
Without Roading Fenders	- 41	- 90	- 25	- 55
Without Secondary Steering	- 53	- 117	- 43	- 94
Without Guard, crankcase	- 11	- 24	- 12	- 27
Without Guard, power train	- 67	- 148	- 52	- 114
With Guard, power train side	11	24	8	17
With Cold Start 120V	54	119	74	163
With Product Link	8	18	6	14
Tires, 1-piece rims				
17.5-25, 12PR (L-2)	- 680	- 1499	- 661	- 1457
17.5-25, 12PR (L-3)	- 663	- 1462	- 645	- 1422
17.5-25, Radial (L-2) VUT	- 437	- 963	- 425	- 937
17.5-25, Radial (L-3) VMT	- 377	- 831	- 367	- 809
Tires, 3-piece rims				
17.5-25, 12PR (L-2)	- 629	- 1387	- 611	- 1348
17.5-25, 12PR (L-3)	- 612	- 1349	- 595	- 1313
17.5-25, Radial (L-2) VUT	- 386	- 851	- 376	- 828
17.5-25, Radial (L-3) VMT	- 326	- 719	- 317	- 700
550/65 R25, Radial (L-3)	- 108	- 238	- 105	- 231
600/65 R25, Radial (L-3)	24	53	23	51
20.5-25, 12PR (L-2)	- 334	- 736	- 325	- 716
20.5-25, 12PR (L-3)	- 263	- 580	- 256	- 564
20.5 R25, Radial (L-5) XMINE D2	616	1358	599	1321
20.5 R25, Radial (L-2) VUT	- 232	- 511	- 226	- 498
20.5 R25, Radial (L-3) VMT	56	123	54	119

*Meets Tier 4 Final/Stage IV/Japan 2014 (Tier 4 Final) emission standards.

Bucket Type		General Purpose								
		Bolt-on Cutting Edges			Bolt-on Teeth & Segments			Bolt-on Teeth		
Ground Engaging Type										
Rated bucket capacity	m ³	2.10	2.30	2.70	2.10	2.30	2.70	2.00	2.20	2.60
	yd ³	2.75	3.01	3.53	2.75	3.01	3.53	2.62	2.88	3.40
Struck capacity	m ³	2.00	2.20	2.60	2.00	2.20	2.60	1.90	2.10	2.50
	yd ³	2.62	2.88	3.40	2.62	2.88	3.40	2.49	2.75	3.27
Bucket width	mm	2550	2550	2750	2550	2550	2750	2550	2550	2750
	ft/in	8'4"	8'4"	9'0"	8'4"	8'4"	9'0"	8'4"	8'4"	9'0"
Dump clearance at full lift and 45° discharge	mm	2747	2698	2650	2643	2593	2544	2643	2593	2544
	ft/in	9'0"	8'10"	8'8"	8'8"	8'6"	8'4"	8'8"	8'6"	8'4"
Reach at full lift and 45° discharge	mm	1168	1205	1243	1271	1307	1344	1271	1307	1344
	ft/in	3'10"	3'11"	4'1"	4'2"	4'3"	4'5"	4'2"	4'3"	4'5"
Reach at 45° discharge and 2130 mm (7'0") clearance	mm	1639	1648	1657	1681	1685	1690	1681	1685	1690
	ft/in	5'5"	5'5"	5'5"	5'6"	5'6"	5'7"	5'6"	5'6"	5'7"
Reach with lift arms horizontal and bucket level	mm	2523	2586	2648	2669	2732	2794	2669	2732	2794
	ft/in	8'3"	8'6"	8'8"	8'9"	9'0"	9'2"	8'9"	9'0"	9'2"
Digging depth	mm	93	93	93	104	104	104	104	104	104
	in	3.7	3.7	3.7	4.1	4.1	4.1	4.1	4.1	4.1
Overall length	mm	7648	7711	7773	7794	7857	7919	7774	7837	7899
	ft/in	25'1"	25'4"	25'6"	25'7"	25'9"	26'0"	25'6"	25'9"	25'11"
Overall height with bucket at full raise	mm	5236	5294	5353	5236	5294	5353	5236	5294	5353
	ft/in	17'2"	17'4"	17'7"	17'2"	17'4"	17'7"	17'2"	17'4"	17'7"
Loader clearance radius with bucket in carry position	mm	5964	5984	6095	6015	6036	6146	6015	6036	6146
	ft/in	19'7"	19'8"	20'0"	19'9"	19'10"	20'2"	19'9"	19'10"	20'2"
Static tipping load straight	kg	8268	8190	8002	8120	8041	7864	8221	8143	7966
	lb	18,228	18,056	17,641	17,902	17,727	17,337	18,124	17,952	17,562
Static tipping load with 40° turn	kg	7070	6999	6819	6926	6953	6684	7025	6953	6784
	lb	15,587	15,430	15,033	15,269	15,329	14,736	15,487	15,329	14,956
Breakout force	kg	8451	8020	7566	8330	7899	7455	8881	8404	7916
	lb	18,631	17,681	16,680	18,365	17,414	16,436	19,579	18,528	17,452
Operating weight	kg	13 060	13 098	13 253	13 181	13 219	13 364	13 098	13 137	13 281
	lb	28,792	28,876	29,218	29,059	29,143	29,463	28,876	28,962	29,280

*Meets Tier 4 Final/Stage IV/Japan 2014 (Tier 4 Final) emission standards.

NOTE: Specifications and ratings conform to all applicable standards recommended by the Society of Automotive Engineers (SAE), including SAE Standards J732 (APR07) which governs loader ratings.

	Change in Operating Weight		Change in Articulated Static Tipping Load	
	kg	lb	kg	lb
Without Ride Control System	- 31	- 68	- 13	- 29
Without Guard, driveshaft	- 43	- 95	- 16	- 34
With Guard, windshield	41	90	23	50
Without Rooding Fenders	- 41	- 90	- 30	- 65
Without Secondary Steering	- 53	- 117	- 51	- 112
Without Guard, crankcase	- 11	- 24	- 15	- 32
Without Guard, power train	- 67	- 148	- 62	- 136
With Guard, power train side	11	24	9	21
With Counterweight, Logger	298	656	417	919
With Cold Start 120V	54	119	88	195
With Product Link	8	18	8	17
Tires, 1-piece rims				
17.5-25, 12PR (L-2)	- 680	- 1499	- 788	- 1736
17.5-25, 12PR (L-3)	- 663	- 1462	- 769	- 1695
17.5-25, Radial (L-2) VUT	- 437	- 963	- 507	- 1117
17.5-25, Radial (L-3) VMT	- 377	- 831	- 437	- 964
Tires, 3-piece rims				
17.5-25, 12PR (L-2)	- 629	- 1387	- 729	- 1606
17.5-25, 12PR (L-3)	- 612	- 1349	- 710	- 1565
17.5-25, Radial (L-2) VUT	- 386	- 851	- 448	- 987
17.5-25, Radial (L-3) VMT	- 326	- 719	- 378	- 834
550/65 R25, Radial (L-3)	- 108	- 238	- 125	- 276
600/65 R25, Radial (L-3)	24	53	28	62
20.5-25, 12PR (L-2)	- 334	- 736	- 387	- 853
20.5-25, 12PR (L-3)	- 263	- 580	- 305	- 672
20.5 R25, Radial (L-5) XMINE D2	616	1358	714	1574
20.5 R25, Radial (L-2) VUT	- 232	- 511	- 269	- 593
20.5 R25, Radial (L-3) VMT	56	123	65	143

*Meets Tier 4 Final/Stage IV/Japan 2014 (Tier 4 Final) emission standards.

Bucket Type		General Purpose								
		Bolt-on Cutting Edges			Bolt-on Teeth & Segments			Bolt-on Teeth		
Ground Engaging Type										
Rated bucket capacity	m ³	2.10	2.30	2.70	2.10	2.30	2.70	2.00	2.20	2.60
	yd ³	2.75	3.01	3.53	2.75	3.01	3.53	2.62	2.88	3.40
Struck capacity	m ³	2.00	2.20	2.60	2.00	2.20	2.60	1.90	2.10	2.50
	yd ³	2.62	2.88	3.40	2.62	2.88	3.40	2.49	2.75	3.27
Bucket width	mm	2550	2550	2750	2550	2550	2750	2550	2550	2750
	ft/in	8'4"	8'4"	9'0"	8'4"	8'4"	9'0"	8'4"	8'4"	9'0"
Dump clearance at full lift and 45° discharge	mm	3240	3191	3143	3136	3085	3037	3136	3085	3037
	ft/in	10'8"	10'6"	10'4"	10'3"	10'1"	10'0"	10'3"	10'1"	10'0"
Reach at full lift and 45° discharge	mm	1405	1442	1479	1508	1543	1580	1508	1543	1580
	ft/in	4'7"	4'9"	4'10"	4'11"	5'1"	5'2"	4'11"	5'1"	5'2"
Reach at 45° discharge and 2130 mm (7'0") clearance	mm	2222	2236	2252	2276	2287	2299	2276	2287	2299
	ft/in	7'3"	7'4"	7'5"	7'6"	7'6"	7'7"	7'6"	7'6"	7'7"
Reach with lift arms horizontal and bucket level	mm	3046	3109	3171	3192	3255	3317	3192	3255	3317
	ft/in	10'0"	10'2"	10'5"	10'6"	10'8"	10'11"	10'6"	10'8"	10'11"
Digging depth	mm	128	128	128	139	139	139	139	139	139
	in	5.0	5.0	5.0	5.5	5.5	5.5	5.5	5.5	5.5
Overall length	mm	8291	8354	8416	8437	8500	8562	8422	8485	8547
	ft/in	27'2"	27'5"	27'7"	27'8"	27'11"	28'1"	27'8"	27'10"	28'0"
Overall height with bucket at full raise	mm	5729	5787	5846	5729	5787	5846	5729	5787	5846
	ft/in	18'10"	19'0"	19'2"	18'10"	19'0"	19'2"	18'10"	19'0"	19'2"
Loader clearance radius with bucket in carry position	mm	6288	6311	6419	6346	6369	6477	6346	6369	6477
	ft/in	20'8"	20'8"	21'1"	20'10"	20'11"	21'3"	20'10"	20'11"	21'3"
Static tipping load straight	kg	6291	6226	6052	6149	6083	5919	6246	6181	6017
	lb	13,869	13,726	13,342	13,556	13,411	13,049	13,770	13,627	13,265
Static tipping load with 40° turn	kg	5328	5268	5100	5189	5128	4970	5284	5223	5067
	lb	11,746	11,614	11,244	11,440	11,305	10,957	11,649	11,515	11,171
Breakout force	kg	8015	7604	7169	7895	7484	7057	8417	7962	7494
	lb	17,670	16,764	15,805	17,406	16,499	15,558	18,556	17,553	16,522
Operating weight	kg	13 339	13 377	13 531	13 459	13 497	13 642	13 377	13 415	13 560
	lb	29,407	29,491	29,831	29,672	29,756	30,075	29,491	29,575	29,895

*Meets Tier 4 Final/Stage IV/Japan 2014 (Tier 4 Final) emission standards.

NOTE: Specifications and ratings conform to all applicable standards recommended by the Society of Automotive Engineers (SAE), including SAE Standards J732 (APR07) which governs loader ratings.

	Change in Operating Weight		Change in Articulated Static Tipping Load	
	kg	lb	kg	lb
Without Ride Control System	- 31	- 68	- 10	- 23
Without Guard, driveshaft	- 43	- 95	- 12	- 27
With Guard, windshield	41	90	18	39
Without Roading Fenders	- 41	- 90	- 23	- 51
Without Secondary Steering	- 53	- 117	- 40	- 88
Without Guard, Crankcase	- 11	- 24	- 11	- 25
Without Guard, power train	- 67	- 148	- 48	- 106
With Guard, power train side	11	24	7	16
With Cold Start 120V	54	119	69	152
With Product Link	8	18	6	13
Tires, 1-piece rims				
17.5-25, 12PR (L-2)	- 680	- 1499	- 613	- 1352
17.5-25, 12PR (L-3)	- 663	- 1462	- 599	- 1320
17.5-25, Radial (L-2) VUT	- 437	- 963	- 395	- 870
17.5-25, Radial (L-3) VMT	- 377	- 831	- 341	- 751
Tires, 3-piece rims				
17.5-25, 12PR (L-2)	- 629	- 1387	- 567	- 1251
17.5-25, 12PR (L-3)	- 612	- 1349	- 553	- 1219
17.5-25, Radial (L-2) VUT	- 386	- 851	- 349	- 769
17.5-25, Radial (L-3) VMT	- 326	- 719	- 295	- 650
550/65 R25, Radial (L-3)	- 108	- 238	- 97	- 214
600/65 R25, Radial (L-3)	24	53	22	49
20.5-25, 12PR (L-2)	- 334	- 736	- 301	- 664
20.5-25, 12PR (L-3)	- 263	- 580	- 237	- 522
20.5 R25, Radial (L-5) XMINE D2	616	1358	556	1226
20.5 R25, Radial (L-2) VUT	- 232	- 511	- 209	- 461
20.5 R25, Radial (L-3) VMT	56	123	51	112

*Meets Tier 4 Final/Stage IV/Japan 2014 (Tier 4 Final) emission standards.

- Performance Data
- 926M* Standard Lift
 - Pallet Forks
 - Construction Forks

Wheel Loaders Integrated Toolcarriers

		Pallet Forks – Fusion		
Fork tine length	mm	1220	1370	1524
	ft/in	4'0"	4'6"	5'0"
Ground to top of tine clearance	mm	3693	3693	3693
	ft/in	12'1"	12'1"	12'1"
Reach with lift arms horizontal and forks level	mm	1569	1569	1569
	ft/in	5'2"	5'2"	5'2"
Overall length	mm	7875	8025	8179
	ft/in	25'10"	26'4"	26'10"
Static tipping load with level arms and forks, straight	kg	6756	6564	6375
	lb	14,894	14,471	14,054
Static tipping load with level arms and forks, full 40° turn	kg	5807	5638	5473
	lb	12,802	12,430	12,066
Operating weight	kg	12 759	12 780	12 802
	lb	28,129	28,175	28,224

		Pallet Forks – ISO		
Fork tine length	mm	1220	1370	1524
	ft/in	4'0"	4'6"	5'0"
Ground to top of tine clearance	mm	3693	3693	3693
	ft/in	12'1"	12'1"	12'1"
Reach with lift arms horizontal and forks level	mm	1595	1595	1595
	ft/in	5'3"	5'3"	5'3"
Overall length	mm	7906	8056	8210
	ft/in	25'11"	26'5"	26'11"
Static tipping load with level arms and forks, straight	kg	6681	6493	6309
	lb	14,729	14,315	13,909
Static tipping load with level arms and forks, full 40° turn	kg	5748	5584	5422
	lb	12,672	12,311	11,953
Operating weight	kg	12 629	12 650	12 672
	lb	27,842	27,888	27,937

		Construction Forks – Fusion	
Fork tine length	mm	1524	1829
	ft/in	5'0"	6'0"
Ground to top of tine clearance	mm	3630	3630
	ft/in	11'11"	11'11"
Reach with lift arms horizontal and forks level	mm	1627	1627
	ft/in	5'4"	5'4"
Overall length	mm	8298	8603
	ft/in	27'3"	28'3"
Static tipping load with level arms and forks, straight	kg	6049	5720
	lb	13,336	12,610
Static tipping load with level arms and forks, full 40° turn	kg	5168	4881
	lb	11,393	10,761
Operating weight	kg	13 094	13 138
	lb	28,867	28,964

*Meets Tier 4 Final/Stage IV/Japan 2014 (Tier 4 Final) emission standards.

NOTE: Dimensions listed are for a machine configured with attachment, counterweights, additional guarding, 80 kg (176 lb) operator, and Michelin 20.5 R25 (L-3) XHA2 tires.

Wheel Loaders Integrated Toolcarriers

- ## Performance Data
- 926M* Standard Lift
 - Material Handling Arm

Handling Arm Position		Material Handling Arm – Fusion		
		Retracted	Mid-position	Extended
Operating load	kg	1928	1636	1420
	lb	4251	3606	3129
Static tipping load, straight	kg	4390	3724	3233
	lb	9678	8210	7128
Static tipping load, full 40° turn	kg	3856	3271	2839
	lb	8501	7211	6259
Operating weight	kg	12 626	12 626	12 626
	lb	27,836	27,836	27,836

*Meets Tier 4 Final/Stage IV/Japan 2014 (Tier 4 Final) emission standards.

NOTE: Dimensions listed are for a machine configured with attachment, counterweights, additional guarding, 80 kg (**176 lb**) operator, and Michelin 20.5 R25 (L-3) XHA2 tires.

- Performance Data
 ● 926M* High Lift
 ● Pallet Forks ● Construction Forks

Wheel Loaders
 Integrated Toolcarriers

		Pallet Forks – Fusion		
Fork tine length	mm	1220	1372	1524
	ft/in	4'0"	4'6"	5'0"
Ground to top of tine clearance	mm	4186	4186	4186
	ft/in	13'9"	13'9"	13'9"
Reach with lift arms horizontal and forks level	mm	2092	2092	2092
	ft/in	6'10"	6'10"	6'10"
Overall length	mm	8528	8678	8832
	ft/in	28'0"	28'6"	29'0"
Static tipping load with level arms and forks, straight	kg	2317	2256	2196
	lb	5108	4974	4841
Static tipping load with level arms and forks, full 40° turn	kg	2780	2707	2635
	lb	6129	5968	5809
Operating weight	kg	3706	3610	3514
	lb	8170	7959	7747

		Pallet Forks – ISO		
Fork tine length	mm	1220	1370	1524
	ft/in	4'0"	4'6"	5'0"
Ground to top of tine clearance	mm	4186	4186	4186
	ft/in	13'9"	13'9"	13'9"
Reach with lift arms horizontal and forks level	mm	2118	2118	2118
	ft/in	6'11"	6'11"	6'11"
Overall length	mm	8557	8707	8861
	ft/in	28'1"	28'7"	29'1"
Static tipping load with level arms and forks, straight	kg	5408	5272	5136
	lb	11,923	11,623	11,323
Static tipping load with level arms and forks, full 40° turn	kg	4620	4501	4382
	lb	10,185	9923	9661
Operating weight	kg	12 907	12 928	12 950
	lb	28,455	28,501	28,550

		Construction Forks – Fusion	
Fork tine length	mm	1524	1829
	ft/in	5'0"	6'0"
Ground to top of tine clearance	mm	4123	4123
	ft/in	13'6"	13'6"
Reach with lift arms horizontal and forks level	mm	2150	2150
	ft/in	7'1"	7'1"
Overall length	mm	8936	9241
	ft/in	29'4"	30'4"
Static tipping load with level arms and forks, straight	kg	4856	4614
	lb	10,706	10,172
Static tipping load with level arms and forks, full 40° turn	kg	4108	3897
	lb	9057	8591
Operating weight	kg	13 372	13 416
	lb	29,480	29,577

*Meets Tier 4 Final/Stage IV/Japan 2014 (Tier 4 Final) emission standards.

NOTE: Dimensions listed are for a machine configured with attachment, counterweights, additional guarding, 80 kg (176 lb) operator, and Michelin 20.5 R25 (L-3) XHA2 tires.

Wheel Loaders Integrated Toolcarriers

- Performance Data
- 926M* High Lift
 - Material Handling Arm

Handling Arm Position		Material Handling Arm – Fusion		
		Retracted	Mid-position	Extended
Operating load	kg	1631	1406	1235
	lb	3596	3099	2723
Static tipping load, straight	kg	3740	3224	2832
	lb	8245	7108	6243
Static tipping load, full 40° turn	kg	3262	2811	2470
	lb	7191	6197	5445
Operating weight	kg	12 904	12 904	12 904
	lb	28,448	28,448	28,448

*Meets Tier 4 Final/Stage IV/Japan 2014 (Tier 4 Final) emission standards.

NOTE: Dimensions listed are for a machine configured with attachment, counterweights, additional guarding, 80 kg (**176 lb**) operator, and Michelin 20.5 R25 (L3) XHA2 tires.

Bucket Type	General Purpose										
		Bolt-on Cutting Edges			Bolt-on Teeth & Segments			Bolt-on Teeth			
Ground Engaging Type											
	Rated bucket capacity	m ³	2.10	2.30	2.50	2.10	2.30	2.50	2.00	2.20	2.40
		yd ³	2.75	3.01	3.27	2.75	3.01	3.27	2.62	2.88	3.14
Struck capacity		m ³	1.90	2.10	2.30	1.90	2.10	2.30	1.80	2.00	2.20
		yd ³	2.49	2.75	3.01	2.49	2.75	3.01	2.35	2.62	2.88
Bucket width		mm	2550	2550	2550	2550	2550	2550	2550	2550	2550
		ft/in	8'4"	8'4"	8'4"	8'4"	8'4"	8'4"	8'4"	8'4"	8'4"
Dump clearance at full lift and 45° discharge		mm	2855	2807	2761	2751	2702	2655	2751	2702	2655
		ft/in	9'4"	9'3"	9'1"	9'0"	8'10"	8'9"	9'0"	8'10"	8'9"
Reach at full lift and 45° discharge		mm	1033	1070	1109	1135	1172	1210	1135	1172	1210
		ft/in	3'5"	3'6"	3'8"	3'9"	3'10"	4'0"	3'9"	3'10"	4'0"
Reach at 45° discharge and 2130 mm (7'0") clearance		mm	1560	1573	1587	1608	1617	1627	1608	1617	1627
		ft/in	5'1"	5'2"	5'2"	5'3"	5'4"	5'4"	5'3"	5'4"	5'4"
Reach with lift arms horizontal and bucket level		mm	2350	2413	2475	2496	2559	2621	2496	2559	2621
		ft/in	7'9"	7'11"	8'1"	8'2"	8'5"	8'7"	8'2"	8'5"	8'7"
Digging depth		mm	100	100	100	111	111	111	111	111	111
		in	3.9	3.9	3.9	4.4	4.4	4.4	4.4	4.4	4.4
Overall length		mm	7488	7551	7613	7634	7697	7759	7614	7677	7739
		ft/in	24'7"	24'9"	25'0"	25'1"	25'3"	25'5"	25'0"	25'2"	25'5"
Overall height with bucket at full raise		mm	5122	5180	5239	5122	5180	5239	5122	5180	5239
		ft/in	16'10"	17'0"	17'2"	16'10"	17'0"	17'2"	16'10"	17'0"	17'2"
Loader clearance radius with bucket in carry position		mm	5933	5951	5970	5980	5999	6018	5980	5999	6018
		ft/in	19'6"	19'6"	19'7"	19'7"	19'8"	19'9"	19'7"	19'8"	19'9"
Static tipping load straight		kg	10 370	10 258	10 119	10 221	10 107	9967	10 323	10 210	10 071
		lb	22,862	22,615	22,309	22,533	22,282	21,973	22,758	22,509	22,203
Static tipping load with 40° turn		kg	8873	8769	8639	8727	8621	8489	8827	8722	8591
		lb	19,562	19,332	19,046	19,240	19,006	18,715	19,460	19,229	18,940
Breakout force		kg	12 881	12 158	11 488	12 760	12 037	11 367	13 687	12 871	12 120
		lb	28,398	26,804	25,327	28,131	26,537	25,060	30,175	28,376	26,720
Operating weight		kg	13 627	13 691	13 789	13 748	13 811	13 910	13 665	13 729	13 828
		lb	30,042	30,183	30,400	30,309	30,448	30,666	30,126	30,267	30,485

*Meets Tier 4 Final/Stage IV/Japan 2014 (Tier 4 Final) emission standards.

NOTE: Specifications and ratings conform to all applicable standards recommended by the Society of Automotive Engineers (SAE), including SAE Standards J732 (APR07) which governs loader ratings.

Wheel Loaders Integrated Toolcarriers

Performance Data ● 930M* Standard Lift Pin On Bucket

Bucket Type		Light Material								
		Bolt-on Cutting Edges			Bolt-on Teeth & Segments			Bolt-on Teeth		
Ground Engaging Type										
Rated bucket capacity	m ³	3.50	4.20	5.00	3.50	4.20	5.00	3.40	4.10	4.90
	yd ³	4.58	5.49	6.54	4.58	5.49	6.54	4.45	5.36	6.41
Struck capacity	m ³	3.30	4.00	4.80	3.30	4.00	4.80	3.20	3.90	4.70
	yd ³	4.32	5.23	6.28	4.32	5.23	6.28	4.19	5.10	6.15
Bucket width	mm	2750	2750	2750	2750	2750	2750	2750	2750	2750
	ft/in	9'0"	9'0"	9'0"	9'0"	9'0"	9'0"	9'0"	9'0"	9'0"
Dump clearance at full lift and 45° discharge	mm	2629	2509	2509	2518	2398	2398	2518	2398	2398
	ft/in	8'8"	8'3"	8'3"	8'3"	7'10"	7'10"	8'3"	7'10"	7'10"
Reach at full lift and 45° discharge	mm	1137	1257	1257	1232	1352	1352	1232	1352	1352
	ft/in	3'9"	4'1"	4'1"	4'1"	4'5"	4'5"	4'1"	4'5"	4'5"
Reach at 45° discharge and 2130 mm (7'0") clearance	mm	1538	1579	1579	1560	1592	1592	1560	1592	1592
	ft/in	5'1"	5'2"	5'2"	5'1"	5'3"	5'3"	5'1"	5'3"	5'3"
Reach with lift arms horizontal and bucket level	mm	2603	2773	2773	2749	2919	2919	2749	2919	2919
	ft/in	8'6"	9'1"	9'1"	9'0"	9'7"	9'7"	9'0"	9'7"	9'7"
Digging depth	mm	100	100	100	111	111	111	111	111	111
	in	3.9	3.9	3.9	4.4	4.4	4.4	4.4	4.4	4.4
Overall length	mm	7741	7911	7911	7887	8057	8057	7867	8037	8037
	ft/in	25'5"	25'11"	25'11"	25'11"	26'5"	26'5"	25'10"	26'4"	26'4"
Overall height with bucket at full raise	mm	5284	5445	5725	5284	5445	5725	5284	5445	5725
	ft/in	17'4"	17'10"	18'9"	17'4"	17'10"	18'9"	17'4"	17'10"	18'9"
Loader clearance radius with bucket in carry position	mm	6099	6152	6152	6148	6202	6202	6148	6202	6202
	ft/in	20'0"	20'2"	20'2"	20'2"	20'4"	20'4"	20'2"	20'4"	20'4"
Static tipping load straight	kg	9796	9512	9474	9653	9366	9328	9759	9474	9437
	lb	21,596	20,970	20,887	21,281	20,648	20,565	21,515	20,887	20,805
Static tipping load with 40° turn	kg	8337	8077	8038	8197	7934	7895	8301	8040	8001
	lb	18,380	17,807	17,721	18,071	17,491	17,405	18,301	17,725	17,639
Breakout force	kg	10 277	9020	8969	10 165	8908	8857	10 786	9406	9353
	lb	22,657	19,886	19,773	22,410	19,639	19,526	23,779	20,737	20,620
Operating weight	kg	14 004	14 134	14 214	14 115	14 245	14 325	14 033	14 163	14 243
	lb	30,873	31,160	31,336	31,118	31,405	31,581	30,937	31,224	31,400

*Meets Tier 4 Final/Stage IV/Japan 2014 (Tier 4 Final) emission standards.

NOTE: Specifications and ratings conform to all applicable standards recommended by the Society of Automotive Engineers (SAE), including SAE Standards J732 (APR07) which governs loader ratings.

	Change in Operating Weight		Change in Articulated Static Tipping Load	
	kg	lb	kg	lb
Without Ride Control System	- 31	- 68	- 14	- 31
Without Guard, driveshaft	- 43	- 95	- 16	- 36
With Guard, windshield	41	90	24	53
Without Rooding Fenders	- 41	- 90	- 31	- 69
Without Secondary Steering	- 53	- 117	- 54	- 118
Without Guard, crankcase	- 11	- 24	- 15	- 34
Without Guard, power train	- 67	- 148	- 65	- 143
With Guard, power train side	11	24	10	22
Without Counterweight, Heavy	- 343	- 756	- 577	- 1273
With Counterweight, Logger	298	656	415	914
With Cold Start 120V	54	119	93	205
With Product Link	8	18	8	18
With Guard, rear wastegate	263	580	472	1041
Tires, 1-piece rims				
17.5-25, Radial (L-2) VUT	- 437	- 963	- 533	- 1175
17.5-25, Radial (L-3) VMT	- 377	- 831	- 460	- 1014
17.5-25, Radial (L-2) XTLA	- 569	- 1254	- 694	- 1530
17.5-25, Radial (L-3) XHA	- 481	- 1060	- 587	- 1294
Tires, 3-piece rims				
17.5-25, 16PR (L-2)	- 494	- 1089	- 603	- 1329
17.5-25, 16PR (L-3)	- 487	- 1074	- 594	- 1310
17.5-25, Radial (L-2) VUT	- 386	- 851	- 471	- 1038
17.5-25, Radial (L-3) VMT	- 326	- 719	- 398	- 877
550/65 R25, Radial (L-3)	- 108	- 238	- 132	- 291
600/65 R25, Radial (L-3)	24	53	29	64
20.5-25, 16PR (L-3)	- 104	- 229	- 127	- 280
20.5 R25, Radial (L-5) XMINE D2	616	1358	751	1656
20.5 R25, Radial (L-2) VUT	- 232	- 511	- 283	- 624
20.5 R25, Radial (L-3) VJT	32	71	39	86
20.5 R25, Radial (L-3) VMT	56	123	68	150

*Meets Tier 4 Final/Stage IV/Japan 2014 (Tier 4 Final) emission standards.

Wheel Loaders Integrated Toolcarriers

Performance Data ● 930M* High Lift Pin On Bucket

Bucket Type		General Purpose								
		Bolt-on Cutting Edges			Bolt-on Teeth & Segments			Bolt-on Teeth		
Ground Engaging Type										
Rated bucket capacity	m ³	2.10	2.30	2.50	2.10	2.30	2.50	2.00	2.20	2.40
	yd ³	2.75	3.01	3.27	2.75	3.01	3.27	2.62	2.88	3.14
Struck capacity	m ³	1.90	2.10	2.30	1.90	2.10	2.30	1.80	2.00	2.20
	yd ³	2.49	2.75	3.01	2.49	2.75	3.01	2.35	2.62	2.88
Bucket width	mm	2550	2550	2550	2550	2550	2550	2550	2550	2550
	ft/in	8'4"	8'4"	8'4"	8'4"	8'4"	8'4"	8'4"	8'4"	8'4"
Dump clearance at full lift and 45° discharge	mm	3448	3400	3353	3344	3295	3247	3344	3295	3247
	ft/in	11'4"	11'2"	11'0"	11'0"	10'10"	10'8"	11'0"	10'10"	10'8"
Reach at full lift and 45° discharge	mm	1353	1391	1429	1456	1492	1530	1456	1492	1530
	ft/in	4'5"	4'7"	4'8"	4'9"	4'11"	5'0"	4'9"	4'11"	5'0"
Reach at 45° discharge and 2130 mm (7'0") clearance	mm	2271	2290	2310	2332	2348	2365	2332	2348	2365
	ft/in	7'5"	7'6"	7'7"	7'8"	7'8"	7'9"	7'8"	7'8"	7'9"
Reach with lift arms horizontal and bucket level	mm	3003	3066	3128	3149	3212	3274	3149	3212	3274
	ft/in	9'10"	10'1"	10'3"	10'4"	10'6"	10'9"	10'4"	10'6"	10'9"
Digging depth	mm	135	135	135	146	146	146	146	146	146
	in	5.3	5.3	5.3	5.7	5.7	5.7	5.7	5.7	5.7
Overall length	mm	8282	8345	8407	8428	8491	8553	8413	8476	8538
	ft/in	27'2"	27'5"	27'7"	27'8"	27'10"	28'1"	27'7"	27'10"	28'0"
Overall height with bucket at full raise	mm	5715	5773	5832	5715	5773	5832	5715	5773	5832
	ft/in	18'9"	18'11"	19'2"	18'9"	18'11"	19'2"	18'9"	18'11"	19'2"
Loader clearance radius with bucket in carry position	mm	6315	6335	6356	6368	6389	6411	6368	6389	6411
	ft/in	20'9"	20'9"	20'10"	20'11"	21'0"	21'0"	20'11"	21'0"	21'0"
Static tipping load straight	kg	7525	7435	7316	7384	7293	7172	7481	7390	7271
	lb	16,590	16,391	16,129	16,279	16,078	15,812	16,493	16,292	16,030
Static tipping load with 40° turn	kg	6383	6298	6184	6244	6158	6043	6339	6254	6140
	lb	14,072	13,885	13,633	13,766	13,576	13,323	13,975	13,788	13,536
Breakout force	kg	12 565	11 859	11 204	12 445	11 739	11 083	13 351	12 553	11 819
	lb	27,701	26,145	24,701	27,437	25,880	24,434	29,434	27,675	26,057
Operating weight	kg	13 859	13 923	14 022	13 980	14 043	14 142	13 897	13 961	14 060
	lb	30,554	30,695	30,913	30,821	30,959	31,178	30,638	30,779	30,997

*Meets Tier 4 Final/Stage IV/Japan 2014 (Tier 4 Final) emission standards.

NOTE: Specifications and ratings conform to all applicable standards recommended by the Society of Automotive Engineers (SAE), including SAE Standards J732 (APR07) which governs loader ratings.

Bucket Type	Light Material									
	Ground Engaging Type	Bolt-on Cutting Edges			Bolt-on Teeth & Segments			Bolt-on Teeth		
Rated bucket capacity		m ³	3.50	4.20	5.00	3.50	4.20	5.00	3.40	4.10
	yd ³	4.58	5.49	6.54	4.58	5.49	6.54	4.45	5.36	6.41
Struck capacity	m ³	3.30	4.00	4.80	3.30	4.00	4.80	3.20	3.90	4.70
	yd ³	4.32	5.23	6.28	4.32	5.23	6.28	4.19	5.10	6.15
Bucket width	mm	2750	2750	2750	2750	2750	2750	2750	2750	2750
	ft/in	9'0"	9'0"	9'0"	9'0"	9'0"	9'0"	9'0"	9'0"	9'0"
Dump clearance at full lift and 45° discharge	mm	3222	3102	3102	3111	2991	2991	3111	2991	2991
	ft/in	10'7"	10'2"	10'2"	10'2"	9'10"	9'10"	10'2"	9'10"	9'10"
Reach at full lift and 45° discharge	mm	1457	1577	1577	1552	1672	1672	1552	1672	1672
	ft/in	4'9"	5'2"	5'2"	5'1"	5'6"	5'6"	5'1"	5'6"	5'6"
Reach at 45° discharge and 2130 mm (7'0") clearance	mm	2280	2340	2340	2320	2375	2375	2320	2375	2375
	ft/in	7'6"	7'8"	7'8"	7'7"	7'10"	7'10"	7'7"	7'10"	7'10"
Reach with lift arms horizontal and bucket level	mm	3256	3426	3426	3402	3572	3572	3402	3572	3572
	ft/in	10'8"	11'3"	11'3"	11'2"	11'9"	11'9"	11'2"	11'9"	11'9"
Digging depth	mm	135	135	135	146	146	146	146	146	146
	in	5.3	5.3	5.3	5.7	5.7	5.7	5.7	5.7	5.7
Overall length	mm	8535	8705	8705	8681	8851	8851	8666	8836	8836
	ft/in	28'0"	28'7"	28'7"	28'6"	29'0"	29'0"	28'5"	29'0"	29'0"
Overall height with bucket at full raise	mm	5877	6038	6317	5877	6038	6317	5877	6038	6317
	ft/in	19'3"	19'10"	20'9"	19'3"	19'10"	20'9"	19'3"	19'10"	20'9"
Loader clearance radius with bucket in carry position	mm	6484	6542	6542	6539	6598	6598	6539	6598	6598
	ft/in	21'3"	21'6"	21'6"	21'5"	21'8"	21'8"	21'5"	21'8"	21'8"
Static tipping load straight	kg	7046	6830	6781	6911	6693	6643	7011	6794	6745
	lb	15,534	15,058	14,950	15,236	14,756	14,645	15,457	14,978	14,870
Static tipping load with 40° turn	kg	5928	5727	5678	5796	5593	5543	5894	5693	5643
	lb	13,069	12,626	12,518	12,778	12,330	12,220	12,994	12,551	12,441
Breakout force	kg	10 019	8791	8740	9908	8679	8628	10 515	9166	9113
	lb	22,088	19,381	19,269	21,844	19,134	19,022	23,182	20,208	20,091
Operating weight	kg	14 236	14 366	14 446	14 347	14 477	14 557	14 265	14 395	14 475
	lb	31,385	31,672	31,848	31,630	31,916	32,093	31,449	31,736	31,912

*Meets Tier 4 Final/Stage IV/Japan 2014 (Tier 4 Final) emission standards.

NOTE: Specifications and ratings conform to all applicable standards recommended by the Society of Automotive Engineers (SAE), including SAE Standards J732 (APR07) which governs loader ratings.

	Change in Operating Weight		Change in Articulated Static Tipping Load	
	kg	lb	kg	lb
Without Ride Control System	- 31	- 68	- 11	- 23
Without Guard, driveshaft	- 43	- 95	- 13	- 28
With Guard, windshield	41	90	18	41
Without Rooding Fenders	- 41	- 90	- 24	- 53
Without Secondary Steering	- 53	- 117	- 41	- 91
Without Guard, crankcase	- 11	- 24	- 12	- 26
Without Guard, power train	- 67	- 148	- 50	- 110
With Guard, power train side	11	24	8	17
Without Counterweight, Heavy	- 343	- 756	- 444	- 980
With Cold Start 120V	54	119	72	158
With Product Link	8	18	6	14
With Guard, rear wastegate	263	580	363	800
Tires, 1-piece rims				
17.5-25, Radial (L-2) VUT	- 437	- 963	- 411	- 906
17.5-25, Radial (L-3) VMT	- 377	- 831	- 354	- 780
17.5-25, Radial (L-2) XTLA	- 569	- 1254	- 534	- 1177
17.5-25, Radial (L-3) XHA	- 481	- 1060	- 452	- 996
Tires, 3-piece rims				
17.5-25, 16PR (L-2)	- 494	- 1089	- 464	- 1023
17.5-25, 16PR (L-3)	- 487	- 1074	- 457	- 1008
17.5-25, Radial (L-2) VUT	- 386	- 851	- 363	- 800
17.5-25, Radial (L-3) VMT	- 326	- 719	- 306	- 675
550/65 R25, Radial (L-3)	- 108	- 238	- 101	- 223
600/65 R25, Radial (L-3)	24	53	23	51
20.5-25, 16PR (L-3)	- 104	- 229	- 98	- 216
20.5 R25, Radial (L-5) XMINE D2	616	1358	578	1274
20.5 R25, Radial (L-2) VUT	- 232	- 511	- 218	- 481
20.5 R25, Radial (L-3) VJT	32	71	30	66
20.5 R25, Radial (L-3) VMT	56	123	53	117

*Meets Tier 4 Final/Stage IV/Japan 2014 (Tier 4 Final) emission standards.

Bucket Type	General Purpose										
		Bolt-on Cutting Edges			Bolt-on Teeth & Segments			Bolt-on Teeth			
Ground Engaging Type											
	Rated bucket capacity	m ³	2.10	2.30	2.50	2.10	2.30	2.50	2.00	2.20	2.40
		yd ³	2.75	3.01	3.27	2.75	3.01	3.27	2.62	2.88	3.14
Struck capacity		m ³	1.90	2.10	2.30	1.90	2.10	2.30	1.80	2.00	2.20
		yd ³	2.49	2.75	3.01	2.49	2.75	3.01	2.35	2.62	2.88
Bucket width		mm	2550	2550	2550	2550	2550	2550	2550	2550	
		ft/in	8'4"	8'4"	8'4"	8'4"	8'4"	8'4"	8'4"	8'4"	
Dump clearance at full lift and 45° discharge		mm	2828	2779	2733	2723	2674	2627	2723	2674	2627
		ft/in	9'3"	9'1"	9'0"	8'11"	8'9"	8'7"	8'11"	8'9"	8'7"
Reach at full lift and 45° discharge		mm	1064	1102	1140	1167	1204	1241	1167	1204	1241
		ft/in	3'6"	3'7"	3'9"	3'10"	3'11"	4'1"	3'10"	3'11"	4'1"
Reach at 45° discharge and 2130 mm (7'0") clearance		mm	1578	1590	1603	1624	1632	1641	1624	1632	1641
		ft/in	5'2"	5'3"	5'3"	5'4"	5'4"	5'5"	5'4"	5'4"	5'5"
Reach with lift arms horizontal and bucket level		mm	2392	2455	2517	2538	2601	2663	2538	2601	2663
		ft/in	7'10"	8'1"	8'3"	8'4"	8'6"	8'9"	8'4"	8'6"	8'9"
Digging depth		mm	100	100	100	111	111	111	111	111	
		in	3.9	3.9	3.9	4.4	4.4	4.4	4.4	4.4	
Overall length		mm	7530	7593	7655	7676	7739	7801	7655	7718	7780
		ft/in	24'8"	24'11"	25'1"	25'2"	25'5"	25'7"	25'1"	25'4"	25'6"
Overall height with bucket at full raise		mm	5147	5205	5264	5147	5205	5264	5147	5205	5264
		ft/in	16'11"	17'1"	17'3"	16'11"	17'1"	17'3"	16'11"	17'1"	17'3"
Loader clearance radius with bucket in carry position		mm	5945	5964	5983	5993	6012	6032	5993	6012	6032
		ft/in	19'6"	19'7"	19'8"	19'8"	19'9"	19'9"	19'8"	19'9"	19'9"
Static tipping load straight		kg	9941	9855	9734	9792	9704	9582	9893	9807	9686
		lb	21,916	21,727	21,460	21,588	21,394	21,125	21,810	21,621	21,354
Static tipping load with 40° turn		kg	8469	8390	8278	8323	8243	8129	8423	8344	8231
		lb	18,671	18,497	18,250	18,349	18,173	17,921	18,570	18,395	18,146
Breakout force		kg	12 366	11 693	11 063	12 245	11 573	10 942	13 106	12 350	11 647
		lb	27,263	25,779	24,390	26,996	25,514	24,123	28,894	27,227	25,677
Operating weight		kg	14 007	14 044	14 127	14 127	14 165	14 247	14 045	14 082	14 165
		lb	30,880	30,962	31,145	31,145	31,228	31,409	30,964	31,045	31,228

*Meets Tier 4 Final/Stage IV/Japan 2014 (Tier 4 Final) emission standards.

NOTE: Specifications and ratings conform to all applicable standards recommended by the Society of Automotive Engineers (SAE), including SAE Standards J732 (APR07) which governs loader ratings.

Wheel Loaders Integrated Toolcarriers

Performance Data ● 930M* Standard Lift Fusion Bucket

Bucket Type	Light Material									
		Bolt-on Cutting Edges			Bolt-on Teeth & Segments			Bolt-on Teeth		
Ground Engaging Type										
Rated bucket capacity	m ³	3.50	4.20	5.00	3.50	4.20	5.00	3.40	4.10	4.90
	yd ³	4.58	5.49	6.54	4.58	5.49	6.54	4.45	5.36	6.41
Struck capacity	m ³	3.30	4.00	4.80	3.30	4.00	4.80	3.20	3.90	4.70
	yd ³	4.32	5.23	6.28	4.32	5.23	6.28	4.19	5.10	6.15
Bucket width	mm	2750	2750	2750	2750	2750	2750	2750	2750	2750
	ft/in	9'0"	9'0"	9'0"	9'0"	9'0"	9'0"	9'0"	9'0"	9'0"
Dump clearance at full lift and 45° discharge	mm	2600	2479	2479	2488	2368	2368	2488	2368	2368
	ft/in	8'6"	8'2"	8'2"	8'2"	7'9"	7'9"	8'2"	7'9"	7'9"
Reach at full lift and 45° discharge	mm	1166	1286	1286	1261	1382	1382	1261	1382	1382
	ft/in	3'10"	4'3"	4'3"	4'2"	4'6"	4'6"	4'2"	4'6"	4'6"
Reach at 45° discharge and 2130 mm (7'0") clearance	mm	1549	1588	1588	1569	1598	1598	1569	1598	1598
	ft/in	5'1"	5'3"	5'3"	5'2"	5'3"	5'3"	5'2"	5'3"	5'3"
Reach with lift arms horizontal and bucket level	mm	2645	2815	2815	2791	2961	2961	2791	2961	2961
	ft/in	8'8"	9'3"	9'3"	9'2"	9'9"	9'9"	9'2"	9'9"	9'9"
Digging depth	mm	100	100	100	111	111	111	111	111	111
	in	3.9	3.9	3.9	4.4	4.4	4.4	4.4	4.4	4.4
Overall length	mm	7783	7953	7953	7929	8099	8099	7909	8079	8079
	ft/in	25'6"	26'1"	26'1"	26'0"	26'7"	26'7"	25'11"	26'6"	26'6"
Overall height with bucket at full raise	mm	5309	5471	5752	5309	5471	5752	5309	5471	5752
	ft/in	17'5"	17'11"	18'10"	17'5"	17'11"	18'10"	17'5"	17'11"	18'10"
Loader clearance radius with bucket in carry position	mm	6112	6166	6166	6162	6217	6217	6162	6217	6217
	ft/in	20'1"	20'3"	20'3"	20'3"	20'5"	20'5"	20'3"	20'5"	20'5"
Static tipping load straight	kg	9395	9118	9081	9253	8973	8936	9359	9081	9044
	lb	20,712	20,102	20,020	20,399	19,782	19,700	20,633	20,020	19,939
Static tipping load with 40° turn	kg	7960	7707	7668	7821	7564	7526	7924	7670	7632
	lb	17,549	16,991	16,905	17,242	16,676	16,592	17,469	16,909	16,826
Breakout force	kg	9921	8730	8682	9809	8619	8570	10 394	9091	9040
	lb	21,872	19,246	19,141	21,625	19,002	18,894	22,915	20,042	19,930
Operating weight	kg	14 367	14 497	14 574	14 478	14 608	14 685	14 396	14 526	14 603
	lb	31,674	31,960	32,130	31,918	32,205	32,375	31,738	32,024	32,194

*Meets Tier 4 Final/Stage IV/Japan 2014 (Tier 4 Final) emission standards.

NOTE: Specifications and ratings conform to all applicable standards recommended by the Society of Automotive Engineers (SAE), including SAE Standards J732 (APR07) which governs loader ratings.

	Change in Operating Weight		Change in Articulated Static Tipping Load	
	kg	lb	kg	lb
Without Ride Control System	- 31	- 68	- 14	- 30
Without Guard, driveshaft	- 43	- 95	- 16	- 36
With Guard, windshield	41	90	24	52
Without Rooding Fenders	- 41	- 90	- 31	- 68
Without Secondary Steering	- 53	- 117	- 53	- 117
Without Guard, crankcase	- 11	- 24	- 15	- 33
Without Guard, power train	- 67	- 148	- 64	- 141
With Guard, power train side	11	24	10	22
Without Counterweight, Heavy	- 343	- 756	- 570	- 1256
With Counterweight, Logger	298	656	415	914
With Cold Start 120V	54	119	92	202
With Product Link	8	18	8	17
With Guard, rear wastegate	263	580	466	1027
Tires, 1-piece rims				
17.5-25, Radial (L-2) VUT	- 437	- 963	- 527	- 1162
17.5-25, Radial (L-3) VMT	- 377	- 831	- 454	- 1001
17.5-25, Radial (L-2) XTLA	- 569	- 1254	- 685	- 1510
17.5-25, Radial (L-3) XHA	- 481	- 1060	- 580	- 1279
Tires, 3-piece rims				
17.5-25, 16PR (L-2)	- 494	- 1089	- 595	- 1312
17.5-25, 16PR (L-3)	- 487	- 1074	- 587	- 1294
17.5-25, Radial (L-2) VUT	- 386	- 851	- 465	- 1025
17.5-25, Radial (L-3) VMT	- 326	- 719	- 393	- 866
550/65 R25, Radial (L-3)	- 108	- 238	- 130	- 287
600/65 R25, Radial (L-3)	24	53	29	64
20.5-25, 16PR (L-3)	- 104	- 229	- 125	- 276
20.5 R25, Radial (L-5) XMINE D2	616	1358	- 742	1636
20.5 R25, Radial (L-2) VUT	- 232	- 511	- 279	- 615
20.5 R25, Radial (L-3) VJT	32	71	39	86
20.5 R25, Radial (L-3) VMT	56	123	67	148

*Meets Tier 4 Final/Stage IV/Japan 2014 (Tier 4 Final) emission standards.

Wheel Loaders Integrated Toolcarriers

Performance Data ● 930M* High Lift Fusion Bucket

Bucket Type		General Purpose								
		Bolt-on Cutting Edges			Bolt-on Teeth & Segments			Bolt-on Teeth		
Ground Engaging Type										
Rated bucket capacity	m ³	2.10	2.30	2.50	2.10	2.30	2.50	2.00	2.20	2.40
	yd ³	2.75	3.01	3.27	2.75	3.01	3.27	2.62	2.88	3.14
Struck capacity	m ³	1.90	2.10	2.30	1.90	2.10	2.30	1.80	2.00	2.20
	yd ³	2.49	2.75	3.01	2.49	2.75	3.01	2.35	2.62	2.88
Bucket width	mm	2550	2550	2550	2550	2550	2550	2550	2550	2550
	ft/in	8'4"	8'4"	8'4"	8'4"	8'4"	8'4"	8'4"	8'4"	8'4"
Dump clearance at full lift and 45° discharge	mm	3421	3372	3325	3316	3267	3219	3316	3267	3219
	ft/in	11'3"	11'1"	10'11"	10'11"	10'9"	10'7"	10'11"	10'9"	10'7"
Reach at full lift and 45° discharge	mm	1385	1422	1460	1487	1524	1561	1487	1524	1561
	ft/in	4'7"	4'8"	4'9"	4'11"	5'0"	5'1"	4'11"	5'0"	5'1"
Reach at 45° discharge and 2130 mm (7'0") clearance	mm	2293	2311	2329	2352	2367	2383	2352	2367	2383
	ft/in	7'6"	7'7"	7'8"	7'9"	7'9"	7'10"	7'9"	7'9"	7'10"
Reach with lift arms horizontal and bucket level	mm	3045	3108	3170	3191	3254	3316	3191	3254	3316
	ft/in	10'0"	10'2"	10'5"	10'6"	10'8"	10'11"	10'6"	10'8"	10'11"
Digging depth	mm	135	135	135	146	146	146	146	146	146
	in	5.3	5.3	5.3	5.7	5.7	5.7	5.7	5.7	5.7
Overall length	mm	8324	8387	8449	8470	8533	8595	8455	8518	8580
	ft/in	27'4"	27'6"	27'9"	27'9"	28'0"	28'2"	27'9"	27'11"	28'2"
Overall height with bucket at full raise	mm	5740	5798	5857	5740	5798	5857	5740	5798	5857
	ft/in	18'10"	19'0"	19'3"	18'10"	19'0"	19'3"	18'10"	19'0"	19'3"
Loader clearance radius with bucket in carry position	mm	6329	6350	6371	6383	6404	6426	6383	6404	6426
	ft/in	20'9"	20'10"	20'11"	20'11"	21'0"	21'1"	20'11"	21'0"	21'1"
Static tipping load straight	kg	7139	7074	6973	6998	6932	6829	7094	7029	6928
	lb	15,739	15,595	15,373	15,428	15,282	15,055	15,640	15,496	15,274
Static tipping load with 40° turn	kg	6014	5954	5858	5875	5814	5717	5970	5910	5814
	lb	13,259	13,126	12,915	12,952	12,818	12,604	13,162	13,029	12,818
Breakout force	kg	12 062	11 405	10 788	11 941	11 284	10 667	12 783	12 044	11 356
	lb	26,592	25,144	23,784	26,326	24,877	23,517	28,182	26,553	25,036
Operating weight	kg	14 239	14 276	14 359	14 359	14 397	14 479	14 277	14 314	14 397
	lb	31,392	31,473	31,656	31,656	31,740	31,921	31,475	31,557	31,740

*Meets Tier 4 Final/Stage IV/Japan 2014 (Tier 4 Final) emission standards.

NOTE: Specifications and ratings conform to all applicable standards recommended by the Society of Automotive Engineers (SAE), including SAE Standards J732 (APR07) which governs loader ratings.

Bucket Type	Light Material									
	Ground Engaging Type	Bolt-on Cutting Edges			Bolt-on Teeth & Segments			Bolt-on Teeth		
Rated bucket capacity		m ³	3.50	4.20	5.00	3.50	4.20	5.00	3.40	4.10
	yd ³	4.58	5.49	6.54	4.58	5.49	6.54	4.45	5.36	6.41
Struck capacity	m ³	3.30	4.00	4.80	3.30	4.00	4.80	3.20	3.90	4.70
	yd ³	4.32	5.23	6.28	4.32	5.23	6.28	4.19	5.10	6.15
Bucket width	mm	2750	2750	2750	2750	2750	2750	2750	2750	2750
	ft/in	9'0"	9'0"	9'0"	9'0"	9'0"	9'0"	9'0"	9'0"	9'0"
Dump clearance at full lift and 45° discharge	mm	3192	3072	3072	3081	2961	2961	3081	2961	2961
	ft/in	10'6"	10'1"	10'1"	10'1"	9'9"	9'9"	10'1"	9'9"	9'9"
Reach at full lift and 45° discharge	mm	1486	1607	1607	1581	1702	1702	1581	1702	1702
	ft/in	4'11"	5'3"	5'3"	5'2"	5'7"	5'7"	5'2"	5'7"	5'7"
Reach at 45° discharge and 2130 mm (7'0") clearance	mm	2295	2355	2355	2334	2388	2388	2334	2388	2388
	ft/in	7'6"	7'9"	7'9"	7'8"	7'10"	7'10"	7'8"	7'10"	7'10"
Reach with lift arms horizontal and bucket level	mm	3298	3468	3468	3444	3614	3614	3444	3614	3614
	ft/in	10'10"	11'5"	11'5"	11'4"	11'10"	11'10"	11'4"	11'10"	11'10"
Digging depth	mm	135	135	135	146	146	146	146	146	146
	in	5.3	5.3	5.3	5.7	5.7	5.7	5.7	5.7	5.7
Overall length	mm	8577	8747	8747	8723	8893	8893	8708	8878	8878
	ft/in	28'2"	28'8"	28'8"	28'7"	29'2"	29'2"	28'7"	29'2"	29'2"
Overall height with bucket at full raise	mm	5902	6064	6345	5902	6064	6345	5902	6064	6345
	ft/in	19'4"	19'11"	20'10"	19'4"	19'11"	20'10"	19'4"	19'11"	20'10"
Loader clearance radius with bucket in carry position	mm	6499	6557	6557	6554	6613	6613	6554	6613	6613
	ft/in	21'4"	21'6"	21'6"	21'6"	21'8"	21'8"	21'6"	21'8"	21'8"
Static tipping load straight	kg	6684	6472	6424	6549	6335	6287	6649	6437	6389
	lb	14,736	14,268	14,162	14,438	13,966	13,860	14,659	14,191	14,085
Static tipping load with 40° turn	kg	5583	5387	5338	5451	5253	5204	5549	5352	5303
	lb	12,308	11,876	11,768	12,017	11,581	11,473	12,233	11,799	11,691
Breakout force	kg	9670	8506	8458	9559	8395	8347	10 131	8858	8807
	lb	21,319	18,753	18,647	21,074	18,508	18,402	22,335	19,529	19,416
Operating weight	kg	14 599	14 729	14 807	14 710	14 840	14 917	14 628	14 758	14 835
	lb	32,185	32,472	32,644	32,430	32,717	32,886	32,249	32,536	32,706

*Meets Tier 4 Final/Stage IV/Japan 2014 (Tier 4 Final) emission standards.

NOTE: Specifications and ratings conform to all applicable standards recommended by the Society of Automotive Engineers (SAE), including SAE Standards J732 (APR07) which governs loader ratings.

	Change in Operating Weight		Change in Articulated Static Tipping Load	
	kg	lb	kg	lb
Without Ride Control System	- 31	- 68	- 11	- 23
Without Guard, driveshaft	- 43	- 95	- 13	- 28
With Guard, windshield	41	90	18	40
Without Rooding Fenders	- 41	- 90	- 24	- 52
Without Secondary Steering	- 53	- 117	- 41	- 90
Without Guard, crankcase	- 11	- 24	- 12	- 26
Without Guard, power train	- 67	- 148	- 49	- 109
With Guard, power train side	11	24	8	17
Without Counterweight, Heavy	- 343	- 756	- 440	- 970
With Cold Start 120V	54	119	71	156
With Product Link	8	18	6	13
With Guard, rear wastegate	263	580	359	791
Tires, 1-piece rims				
17.5-25, Radial (L-2) VUT	- 437	- 963	- 406	- 895
17.5-25, Radial (L-3) VMT	- 377	- 831	- 351	- 774
17.5-25, Radial (L-2) XTLA	- 569	- 1254	- 529	- 1166
17.5-25, Radial (L-3) XHA	- 481	- 1060	- 447	- 985
Tires, 3-piece rims				
17.5-25, 16PR (L-2)	- 494	- 1089	- 460	- 1014
17.5-25, 16PR (L-3)	- 487	- 1074	- 453	- 999
17.5-25, Radial (L-2) VUT	- 386	- 851	- 359	- 791
17.5-25, Radial (L-3) VMT	- 326	- 719	- 303	- 668
550/65 R25, Radial (L-3)	- 108	- 238	- 100	- 220
600/65 R25, Radial (L-3)	24	53	22	49
20.5-25, 16PR (L-3)	- 104	- 229	- 97	- 214
20.5 R25, Radial (L-5) XMINE D2	616	1358	573	1263
20.5 R25, Radial (L-2) VUT	- 232	- 511	- 216	- 476
20.5 R25, Radial (L-3) VJT	32	71	30	66
20.5 R25, Radial (L-3) VMT	56	123	52	115

*Meets Tier 4 Final/Stage IV/Japan 2014 (Tier 4 Final) emission standards.

Bucket Type		General Purpose							
		Bolt-on Cutting Edges				Bolt-on Teeth & Segments			
Ground Engaging Type									
Rated bucket capacity	m ³	2.10	2.30	2.50	2.70	2.10	2.30	2.50	2.70
	yd ³	2.75	3.01	3.27	3.53	2.75	3.01	3.27	3.53
Struck capacity	m ³	2.00	2.20	2.40	2.60	2.00	2.20	2.40	2.60
	yd ³	2.62	2.88	3.14	3.40	2.62	2.88	3.14	3.40
Bucket width	mm	2550	2550	2750	2750	2550	2550	2750	2750
	ft/in	8'4"	8'4"	9'0"	9'0"	8'4"	8'4"	9'0"	9'0"
Dump clearance at full lift and 45° discharge	mm	2747	2698	2698	2650	2643	2593	2593	2544
	ft/in	9'0"	8'10"	8'10"	8'8"	8'8"	8'6"	8'6"	8'4"
Reach at full lift and 45° discharge	mm	1168	1205	1205	1243	1271	1307	1307	1344
	ft/in	3'10"	3'11"	3'11"	4'1"	4'2"	4'3"	4'3"	4'5"
Reach at 45° discharge and 2130 mm (7'0") clearance	mm	1639	1648	1648	1657	1681	1685	1685	1690
	ft/in	5'5"	5'5"	5'5"	5'5"	5'6"	5'6"	5'6"	5'7"
Reach with lift arms horizontal and bucket level	mm	2523	2586	2586	2648	2669	2732	2732	2794
	ft/in	8'3"	8'6"	8'6"	8'8"	8'9"	9'0"	9'0"	9'2"
Digging depth	mm	93	93	93	93	104	104	104	104
	in	3.7	3.7	3.7	3.7	4.1	4.1	4.1	4.1
Overall length	mm	7655	7718	7718	7780	7801	7864	7864	7926
	ft/in	25'1"	25'4"	25'4"	25'6"	25'7"	25'10"	25'10"	26'0"
Overall height with bucket at full raise	mm	5236	5294	5294	5353	5236	5294	5294	5353
	ft/in	17'2"	17'4"	17'4"	17'7"	17'2"	17'4"	17'4"	17'7"
Loader clearance radius with bucket in carry position	mm	5964	5984	6075	6095	6015	6036	6125	6146
	ft/in	19'7"	19'8"	19'11"	20'0"	19'9"	19'10"	20'1"	20'2"
Static tipping load straight	kg	9450	9367	9270	9174	9303	9218	9133	9035
	lb	20,834	20,651	20,437	20,225	20,510	20,322	20,135	19,919
Static tipping load with 40° turn	kg	8047	7971	7876	7787	7902	7825	7742	7651
	lb	17,741	17,573	17,364	17,167	17,421	17,251	17,068	16,868
Breakout force	kg	10 980	10 432	10 375	9873	10 859	10 311	10 264	9762
	lb	24,207	22,999	22,873	21,766	23,940	22,732	22,628	21,522
Operating weight	kg	13 973	14 011	14 114	14 165	14 093	14 131	14 225	14 276
	lb	30,805	30,889	31,116	31,228	31,070	31,153	31,361	31,473

*Meets Tier 4 Final/Stage IV/Japan 2014 (Tier 4 Final) emission standards.

NOTE: Specifications and ratings conform to all applicable standards recommended by the Society of Automotive Engineers (SAE), including SAE Standards J732 (APR07) which governs loader ratings.

Wheel Loaders Integrated Toolcarriers

Performance Data ● 930M* Standard Lift ISO Bucket

Bucket Type		General Purpose			
Ground Engaging Type		Bolt-on Teeth			
Rated bucket capacity	m ³	2.00	2.20	2.40	2.60
	yd ³	2.62	2.88	3.14	3.40
Struck capacity	m ³	1.90	2.10	2.30	2.50
	yd ³	2.49	2.75	3.01	3.27
Bucket width	mm	2550	2550	2750	2750
	ft/in	8'4"	8'4"	9'0"	9'0"
Dump clearance at full lift and 45° discharge	mm	2643	2593	2593	2544
	ft/in	8'8"	8'6"	8'6"	8'4"
Reach at full lift and 45° discharge	mm	1271	1307	1307	1344
	ft/in	4'2"	4'3"	4'3"	4'5"
Reach at 45° discharge and 2130 mm (7'0") clearance	mm	1681	1685	1685	1690
	ft/in	5'6"	5'6"	5'6"	5'7"
Reach with lift arms horizontal and bucket level	mm	2669	2732	2732	2794
	ft/in	8'9"	9'0"	9'0"	9'2"
Digging depth	mm	104	104	104	104
	in	4.1	4.1	4.1	4.1
Overall length	mm	7781	7844	7844	7906
	ft/in	25'6"	25'9"	25'9"	25'11"
Overall height with bucket at full raise	mm	5236	5294	5294	5353
	ft/in	17'2"	17'4"	17'4"	17'7"
Loader clearance radius with bucket in carry position	mm	6015	6036	6125	6146
	ft/in	19'9"	19'10"	20'1"	20'2"
Static tipping load straight	kg	9404	9320	9235	9138
	lb	20,732	20,547	20,360	20,146
Static tipping load with 40° turn	kg	8001	7925	7842	7752
	lb	17,639	17,472	17,289	17,090
Breakout force	kg	11 553	10 944	10 894	10 340
	lb	25,470	24,128	24,017	22,796
Operating weight	kg	14 011	14 049	14 142	14 194
	lb	30,889	30,973	31,178	31,292

*Meets Tier 4 Final/Stage IV/Japan 2014 (Tier 4 Final) emission standards.

NOTE: Specifications and ratings conform to all applicable standards recommended by the Society of Automotive Engineers (SAE), including SAE Standards J732 (APR07) which governs loader ratings.

	Change in Operating Weight		Change in Articulated Static Tipping Load	
	kg	lb	kg	lb
Without Ride Control System	- 31	- 68	- 13	- 29
Without Guard, driveshaft	- 43	- 95	- 16	- 34
With Guard, windshield	41	90	23	50
Without Rooding Fenders	- 41	- 90	- 30	- 65
Without Secondary Steering	- 53	- 117	- 51	- 112
Without Guard, crankcase	- 11	- 24	- 15	- 32
Without Guard, power train	- 67	- 148	- 62	- 136
With Guard, power train side	11	24	9	21
Without Counterweight, Heavy	- 343	- 756	- 549	- 1209
With Counterweight, Logger	298	656	415	914
With Cold Start 120V	54	119	88	195
With Product Link	8	18	8	17
With Guard, rear wastegate	263	580	448	988
Tires, 1-piece rims				
17.5-25, Radial (L-2) VUT	- 437	- 963	- 507	- 1118
17.5-25, Radial (L-3) VMT	- 377	- 831	- 437	- 963
17.5-25, Radial (L-2) XTLA	- 569	- 1254	- 660	- 1455
17.5-25, Radial (L-3) XHA	- 481	- 1060	- 558	- 1230
Tires, 3-piece rims				
17.5-25, 16PR (L-2)	- 494	- 1089	- 573	- 1263
17.5-25, 16PR (L-3)	- 487	- 1074	- 565	- 1246
17.5-25, Radial (L-2) VUT	- 386	- 851	- 448	- 988
17.5-25, Radial (L-3) VMT	- 326	- 719	- 378	- 833
550/65 R25, Radial (L-3)	- 108	- 238	- 125	- 276
600/65 R25, Radial (L-3)	24	53	28	62
20.5-25, 16PR (L-3)	- 104	- 229	- 121	- 267
20.5 R25, Radial (L-5) XMINE D2	616	1358	714	1574
20.5 R25, Radial (L-2) VUT	- 232	- 511	- 269	- 593
20.5 R25, Radial (L-3) VJT	32	71	37	82
20.5 R25, Radial (L-3) VMT	56	123	65	143

*Meets Tier 4 Final/Stage IV/Japan 2014 (Tier 4 Final) emission standards.

Wheel Loaders Integrated Toolcarriers

Performance Data ● 930M* High Lift ISO Bucket

Bucket Type	Ground Engaging Type	General Purpose							
		Bolt-on Cutting Edges				Bolt-on Teeth & Segments			
Rated bucket capacity	m ³	2.10	2.30	2.50	2.70	2.10	2.30	2.50	2.70
	yd ³	2.75	3.01	3.27	3.53	2.75	3.01	3.27	3.53
Struck capacity	m ³	2.00	2.20	2.40	2.60	2.00	2.20	2.40	2.60
	yd ³	2.62	2.88	3.14	3.40	2.62	2.88	3.14	3.40
Bucket width	mm	2550	2550	2750	2750	2550	2550	2750	2750
	ft/in	8'4"	8'4"	9'0"	9'0"	8'4"	8'4"	9'0"	9'0"
Dump clearance at full lift and 45° discharge	mm	3340	3291	3291	3243	3235	3185	3185	3137
	ft/in	10'11"	10'10"	10'10"	10'8"	10'7"	10'5"	10'5"	10'4"
Reach at full lift and 45° discharge	mm	1488	1525	1525	1563	1591	1627	1627	1664
	ft/in	4'11"	5'0"	5'0"	5'2"	5'3"	5'4"	5'4"	5'6"
Reach at 45° discharge and 2130 mm (7'0") clearance	mm	2364	2379	2379	2395	2420	2432	2432	2445
	ft/in	7'9"	7'10"	7'10"	7'10"	7'11"	8'0"	8'0"	8'0"
Reach with lift arms horizontal and bucket level	mm	3176	3239	3239	3301	3322	3385	3385	3447
	ft/in	10'5"	10'8"	10'8"	10'10"	10'11"	11'1"	11'1"	11'4"
Digging depth	mm	128	128	128	128	139	139	139	139
	in	5.0	5.0	5.0	5.0	5.5	5.5	5.5	5.5
Overall length	mm	8451	8514	8514	8576	8597	8660	8660	8722
	ft/in	27'9"	27'11"	27'11"	28'2"	28'2"	28'5"	28'5"	28'7"
Overall height with bucket at full raise	mm	5829	5887	5887	5946	5829	5887	5887	5946
	ft/in	19'1"	19'4"	19'4"	19'6"	19'1"	19'4"	19'4"	19'6"
Loader clearance radius with bucket in carry position	mm	6360	6383	6468	6490	6417	6441	6525	6547
	ft/in	20'10"	20'11"	21'3"	21'3"	21'1"	21'2"	21'5"	21'6"
Static tipping load straight	kg	6866	6802	6706	6628	6725	6661	6575	6497
	lb	15,137	14,996	14,784	14,612	14,826	14,685	14,495	14,323
Static tipping load with 40° turn	kg	5781	5722	5628	5555	5644	5583	5500	5426
	lb	12,745	12,615	12,408	12,247	12,443	12,308	12,125	11,962
Breakout force	kg	10 704	10 169	10 112	9622	10 583	10 048	10 001	9510
	lb	23,598	22,419	22,293	21,213	23,332	22,152	22,049	20,966
Operating weight	kg	14 205	14 243	14 346	14 397	14 325	14 363	14 457	14 508
	lb	31,317	31,400	31,627	31,740	31,581	31,665	31,872	31,985

*Meets Tier 4 Final/Stage IV/Japan 2014 (Tier 4 Final) emission standards.

NOTE: Specifications and ratings conform to all applicable standards recommended by the Society of Automotive Engineers (SAE), including SAE Standards J732 (APR07) which governs loader ratings.

Bucket Type		General Purpose			
Ground Engaging Type		Bolt-on Teeth			
Rated bucket capacity	m ³	2.00	2.20	2.40	2.60
	yd ³	2.62	2.88	3.14	3.40
Struck capacity	m ³	1.90	2.10	2.30	2.50
	yd ³	2.49	2.75	3.01	3.27
Bucket width	mm	2550	2550	2750	2750
	ft/in	8'4"	8'4"	9'0"	9'0"
Dump clearance at full lift and 45° discharge	mm	3235	3185	3185	3137
	ft/in	10'7"	10'5"	10'5"	10'4"
Reach at full lift and 45° discharge	mm	1591	1627	1627	1664
	ft/in	5'3"	5'4"	5'4"	5'6"
Reach at 45° discharge and 2130 mm (7'0") clearance	mm	2420	2432	2432	2445
	ft/in	7'11"	8'0"	8'0"	8'0"
Reach with lift arms horizontal and bucket level	mm	3322	3385	3385	3447
	ft/in	10'11"	11'1"	11'1"	11'4"
Digging depth	mm	139	139	139	139
	in	5.5	5.5	5.5	5.5
Overall length	mm	8582	8645	8645	8707
	ft/in	28'2"	28'4"	28'4"	28'7"
Overall height with bucket at full raise	mm	5829	5887	5887	5946
	ft/in	19'1"	19'4"	19'4"	19'6"
Loader clearance radius with bucket in carry position	mm	6417	6441	6525	6547
	ft/in	21'1"	21'2"	21'5"	21'6"
Static tipping load straight	kg	6821	6757	6672	6594
	lb	15,038	14,897	14,709	14,537
Static tipping load with 40° turn	kg	5738	5678	5595	5522
	lb	12,650	12,518	12,335	12,174
Breakout force	kg	11 263	10 669	10 619	10 077
	lb	24,831	23,521	23,411	22,216
Operating weight	kg	14 243	14 281	14 374	14 426
	lb	31,400	31,484	31,689	31,804

*Meets Tier 4 Final/Stage IV/Japan 2014 (Tier 4 Final) emission standards.

NOTE: Specifications and ratings conform to all applicable standards recommended by the Society of Automotive Engineers (SAE), including SAE Standards J732 (APR07) which governs loader ratings.

	Change in Operating Weight		Change in Articulated Static Tipping Load	
	kg	lb	kg	lb
Without Ride Control System	- 31	- 68	- 10	- 23
Without Guard, driveshaft	- 43	- 95	- 12	- 27
With Guard, windshield	41	90	18	39
Without Rooding Fenders	- 41	- 90	- 23	- 51
Without Secondary Steering	- 53	- 117	- 40	- 88
Without Guard, crankcase	- 11	- 24	- 11	- 25
Without Guard, power train	- 67	- 148	- 48	- 106
With Guard, power train side	11	24	7	16
Without Counterweight, Heavy	- 343	- 756	- 427	- 942
With Cold Start 120V	54	119	69	152
With Product Link	8	18	6	13
With Guard, rear wastegate	263	580	349	769
Tires, 1-piece rims				
17.5-25, Radial (L-2) VUT	- 437	- 963	- 395	- 871
17.5-25, Radial (L-3) VMT	- 377	- 831	- 341	- 752
17.5-25, Radial (L-2) XTLA	- 569	- 1254	- 514	- 1133
17.5-25, Radial (L-3) XHA	- 481	- 1060	- 434	- 957
Tires, 3-piece rims				
17.5-25, 16PR (L-2)	- 494	- 1089	- 446	- 983
17.5-25, 16PR (L-3)	- 487	- 1074	- 440	- 970
17.5-25, Radial (L-2) VUT	- 386	- 851	- 349	- 769
17.5-25, Radial (L-3) VMT	- 326	- 719	- 295	- 650
550/65 R25, Radial (L-3)	- 108	- 238	- 97	- 214
600/65 R25, Radial (L-3)	24	53	22	49
20.5-25, 16PR (L-3)	- 104	- 229	- 94	- 207
20.5 R25, Radial (L-5) XMINE D2	616	1358	556	1226
20.5 R25, Radial (L-2) VUT	- 232	- 511	- 209	- 461
20.5 R25, Radial (L-3) VJT	32	71	29	64
20.5 R25, Radial (L-3) VMT	56	123	51	112

*Meets Tier 4 Final/Stage IV/Japan 2014 (Tier 4 Final) emission standards.

- Performance Data
- 930M* Standard Lift
 - Pallet Forks ● Construction Forks

Wheel Loaders Integrated Toolcarriers

		Pallet Forks – Fusion		
Fork tine length	mm	1220	1370	1524
	ft/in	4'0"	4'6"	5'0"
Ground to top of tine clearance	mm	3693	3693	3693
	ft/in	12'1"	12'1"	12'1"
Reach with lift arms horizontal and forks level	mm	1569	1569	1569
	ft/in	5'2"	5'2"	5'2"
Overall length	mm	7882	8032	8186
	ft/in	25'10"	26'4"	26'10"
Static tipping load with level arms and forks, straight	kg	7689	7473	7262
	lb	16,951	16,475	16,010
Static tipping load with level arms and forks, full 40° turn	kg	6577	6389	6205
	lb	14,500	14,085	13,680
Operating weight	kg	13 671	13 693	13 714
	lb	30,139	30,188	30,234

		Pallet Forks – ISO		
Fork tine length	mm	1220	1370	1524
	ft/in	4'0"	4'6"	5'0"
Ground to top of tine clearance	mm	3693	3693	3693
	ft/in	12'1"	12'1"	12'1"
Reach with lift arms horizontal and forks level	mm	1595	1595	1595
	ft/in	5'3"	5'3"	5'3"
Overall length	mm	7913	8063	8217
	ft/in	26'0"	26'5"	27'0"
Static tipping load with level arms and forks, straight	kg	7596	7386	7180
	lb	16,746	16,283	15,829
Static tipping load with level arms and forks, full 40° turn	kg	6503	6321	6141
	lb	14,337	13,935	13,539
Operating weight	kg	13 541	13 562	13 584
	lb	29,853	29,899	29,948

		Construction Forks – Fusion	
Fork tine length	mm	1524	1829
	ft/in	5'0"	6'0"
Ground to top of tine clearance	mm	3630	3630
	ft/in	11'11"	11'11"
Reach with lift arms horizontal and forks level	mm	1627	1627
	ft/in	5'4"	5'4"
Overall length	mm	8305	8610
	ft/in	27'3"	28'3"
Static tipping load with level arms and forks, straight	kg	6919	6550
	lb	15,254	14,440
Static tipping load with level arms and forks, full 40° turn	kg	5887	5566
	lb	12,979	12,271
Operating weight	kg	14 006	14 050
	lb	30,878	30,975

*Meets Tier 4 Final/Stage IV/Japan 2014 (Tier 4 Final) emission standards.

NOTE: Dimensions listed are for a machine configured with attachment, counterweights, additional guarding, 80 kg (176 lb) operator, and Michelin 20.5 R25 (L-3) XHA2 tires.

Wheel Loaders Integrated Toolcarriers

- ## Performance Data
- 930M* Standard Lift
 - Material Handling Arm

Handling Arm Position		Material Handling Arm – Fusion		
		Retracted	Mid-position	Extended
Operating load	kg	2183	1851	1607
	lb	4812	4081	3543
Static tipping load, straight	kg	4994	4236	3677
	lb	11,010	9339	8106
Static tipping load, full 40° turn	kg	4365	3702	3214
	lb	9623	8162	7086
Operating weight	kg	13 538	13 538	13 538
	lb	29,846	29,846	29,846

*Meets Tier 4 Final/Stage IV/Japan 2014 (Tier 4 Final) emission standards.

NOTE: Dimensions listed are for a machine configured with attachment, counterweights, additional guarding, 80 kg (**176 lb**) operator, and Michelin 20.5 R25 (L-3) XHA2 tires.

Performance Data
 ● 930M* High Lift
 ● Pallet Forks ● Construction Forks

Wheel Loaders
 Integrated Toolcarriers

		Pallet Forks – Fusion		
Fork tine length	mm	1220	1370	1524
	ft/in	4'0"	4'6"	5'0"
Ground to top of tine clearance	mm	4286	4286	4286
	ft/in	14'1"	14'1"	14'1"
Reach with lift arms horizontal and forks level	mm	2222	2222	2222
	ft/in	7'3"	7'3"	7'3"
Overall length	mm	8689	8839	8993
	ft/in	28'6"	29'0"	29'6"
Static tipping load with level arms and forks, straight	kg	5916	5772	5629
	lb	13,043	12,725	12,410
Static tipping load with level arms and forks, full 40° turn	kg	5015	4889	4765
	lb	11,056	10,778	10,505
Operating weight	kg	13 904	13 925	13 946
	lb	30,653	30,699	30,746

		Pallet Forks – ISO		
Fork tine length	mm	1220	1370	1524
	ft/in	4'0"	4'6"	5'0"
Ground to top of tine clearance	mm	4286	4286	4286
	ft/in	14'1"	14'1"	14'1"
Reach with lift arms horizontal and forks level	mm	2248	2248	2248
	ft/in	7'5"	7'5"	7'5"
Overall length	mm	8718	8868	9022
	ft/in	28'7"	29'1"	29'7"
Static tipping load with level arms and forks, straight	kg	5890	5748	5607
	lb	12,985	12,672	12,361
Static tipping load with level arms and forks, full 40° turn	kg	5001	4877	4755
	lb	11,025	10,752	10,483
Operating weight	kg	13 773	13 794	13 816
	lb	30,364	30,411	30,459

		Construction Forks – Fusion	
Fork tine length	mm	1524	1829
	ft/in	5'0"	6'0"
Ground to top of tine clearance	mm	4223	4223
	ft/in	13'10"	13'10"
Reach with lift arms horizontal and forks level	mm	2280	2280
	ft/in	7'6"	7'6"
Overall length	mm	9094	9399
	ft/in	29'10"	30'10"
Static tipping load with level arms and forks, straight	kg	5322	5069
	lb	11,733	11,175
Static tipping load with level arms and forks, full 40° turn	kg	4476	4256
	lb	9868	9383
Operating weight	kg	14 238	14 283
	lb	31,389	31,489

*Meets Tier 4 Final/Stage IV/Japan 2014 (Tier 4 Final) emission standards.

NOTE: Dimensions listed are for a machine configured with attachment, counterweights, additional guarding, 80 kg (176 lb) operator, and Michelin 20.5 R25 (L-3) XHA2 tires.

Wheel Loaders Integrated Toolcarriers

- Performance Data
- 930M* High Lift
 - Material Handling Arm

Handling Arm Position		Material Handling Arm – Fusion		
		Retracted	Mid-position	Extended
Operating load	kg	1785	1544	1360
	lb	3935	3404	2998
Static tipping load, straight	kg	4119	3563	3139
	lb	9081	7855	6920
Static tipping load, full 40° turn	kg	3570	3088	2720
	lb	7870	6808	5997
Operating weight	kg	13 771	13 771	13 771
	lb	30,360	30,360	30,360

*Meets Tier 4 Final/Stage IV/Japan 2014 (Tier 4 Final) emission standards.

NOTE: Dimensions listed are for a machine configured with attachment, counterweights, additional guarding, 80 kg (**176 lb**) operator, and Michelin 20.5 R25 (L-3) XHA2 tires.

Bucket Type	General Purpose									
		Bolt-on Cutting Edges			Bolt-on Teeth & Segments			Bolt-on Teeth		
Ground Engaging Type										
Rated bucket capacity	m ³	2.50	2.70	2.90	2.50	2.70	2.90	2.40	2.60	2.80
	yd ³	3.27	3.53	3.79	3.27	3.53	3.79	3.14	3.40	3.66
Struck capacity	m ³	2.30	2.50	2.70	2.30	2.50	2.70	2.20	2.40	2.60
	yd ³	3.01	3.27	3.53	3.01	3.27	3.53	2.88	3.14	3.40
Bucket width	mm	2750	2750	2750	2750	2750	2750	2750	2750	2750
	ft/in	9'0"	9'0"	9'0"	9'0"	9'0"	9'0"	9'0"	9'0"	9'0"
Dump clearance at full lift and 45° discharge	mm	2869	2822	2786	2764	2716	2680	2764	2716	2680
	ft/in	9'5"	9'3"	9'2"	9'1"	8'11"	8'10"	9'1"	8'11"	8'10"
Reach at full lift and 45° discharge	mm	1108	1146	1178	1210	1247	1278	1210	1247	1278
	ft/in	3'8"	3'9"	3'10"	4'0"	4'1"	4'2"	4'0"	4'1"	4'2"
Reach at 45° discharge and 2130 mm (7'0") clearance	mm	1637	1652	1664	1684	1696	1705	1684	1696	1705
	ft/in	5'4"	5'5"	5'6"	5'6"	5'7"	5'7"	5'6"	5'7"	5'7"
Reach with lift arms horizontal and bucket level	mm	2452	2514	2563	2598	2660	2709	2598	2660	2709
	ft/in	8'1"	8'3"	8'5"	8'6"	8'9"	8'11"	8'6"	8'9"	8'11"
Digging depth	mm	100	100	100	112	112	112	112	112	112
	in	3.9	3.9	3.9	4.4	4.4	4.4	4.4	4.4	4.4
Overall length	mm	7604	7666	7715	7750	7812	7861	7729	7791	7840
	ft/in	24'11"	25'2"	25'4"	25'5"	25'8"	25'9"	25'4"	25'7"	25'9"
Overall height with bucket at full raise	mm	5242	5301	5348	5242	5301	5348	5242	5301	5348
	ft/in	17'2"	17'5"	17'7"	17'2"	17'5"	17'7"	17'2"	17'5"	17'7"
Loader clearance radius with bucket in carry position	mm	6117	6136	6150	6164	6183	6198	6164	6183	6198
	ft/in	20'1"	20'2"	20'2"	20'3"	20'3"	20'4"	20'3"	20'3"	20'4"
Static tipping load straight	kg	12 344	12 245	12 161	12 206	12 105	12 020	12 309	12 209	12 125
	lb	27,214	26,996	26,810	26,910	26,687	26,500	27,137	26,916	26,731
Static tipping load with 40° turn	kg	10 517	10 426	10 350	10 382	10 289	10 212	10 482	10 391	10 314
	lb	23,186	22,985	22,818	22,888	22,683	22,514	23,109	22,908	22,738
Breakout force	kg	13 813	13 082	12 552	13 701	12 971	12 441	14 640	13 821	13 229
	lb	30,453	28,841	27,673	30,206	28,596	27,428	32,276	30,470	29,165
Operating weight	kg	16 001	16 046	16 082	16 112	16 157	16 193	16 030	16 074	16 111
	lb	35,276	35,375	35,455	35,521	35,620	35,699	35,340	35,437	35,519

*Meets Tier 4 Final/Stage IV/Japan 2014 (Tier 4 Final) emission standards.

NOTE: Specifications and ratings conform to all applicable standards recommended by the Society of Automotive Engineers (SAE), including SAE Standards J732 (APR07) which governs loader ratings.

Wheel Loaders Integrated Toolcarriers

Performance Data ● 938M* Standard Lift Pin On Bucket

Bucket Type	Light Material									
	Ground Engaging Type	Bolt-on Cutting Edges			Bolt-on Teeth & Segments			Bolt-on Teeth		
Rated bucket capacity		m ³	3.50	4.20	5.00	3.50	4.20	5.00	3.40	4.10
	yd ³	4.58	5.49	6.54	4.58	5.49	6.54	4.45	5.36	6.41
Struck capacity	m ³	3.30	4.00	4.80	3.30	4.00	4.80	3.20	3.90	4.70
	yd ³	4.32	5.23	6.28	4.32	5.23	6.28	4.19	5.10	6.15
Bucket width	mm	2750	2750	2750	2750	2750	2750	2750	2750	2750
	ft/in	9'0"	9'0"	9'0"	9'0"	9'0"	9'0"	9'0"	9'0"	9'0"
Dump clearance at full lift and 45° discharge	mm	2691	2571	2571	2580	2460	2460	2580	2460	2460
	ft/in	8'10"	8'5"	8'5"	8'6"	8'1"	8'1"	8'6"	8'1"	8'1"
Reach at full lift and 45° discharge	mm	1174	1294	1294	1269	1389	1389	1269	1389	1389
	ft/in	3'10"	4'3"	4'3"	4'2"	4'7"	4'7"	4'2"	4'7"	4'7"
Reach at 45° discharge and 2130 mm (7'0") clearance	mm	1608	1654	1654	1634	1672	1672	1634	1672	1672
	ft/in	5'3"	5'5"	5'5"	5'4"	5'6"	5'6"	5'4"	5'6"	5'6"
Reach with lift arms horizontal and bucket level	mm	2642	2812	2812	2788	2958	2958	2788	2958	2958
	ft/in	8'8"	9'3"	9'3"	9'2"	9'8"	9'8"	9'2"	9'8"	9'8"
Digging depth	mm	100	100	100	112	112	112	112	112	112
	in	3.9	3.9	3.9	4.4	4.4	4.4	4.4	4.4	4.4
Overall length	mm	7794	7964	7964	7940	8110	8110	7919	8089	8089
	ft/in	25'7"	26'2"	26'2"	26'1"	26'7"	26'7"	26'0"	26'6"	26'6"
Overall height with bucket at full raise	mm	5346	5507	5786	5346	5507	5786	5346	5507	5786
	ft/in	17'6"	18'1"	19'0"	17'6"	18'1"	19'0"	17'6"	18'1"	19'0"
Loader clearance radius with bucket in carry position	mm	6174	6227	6227	6223	6277	6277	6223	6277	6277
	ft/in	20'3"	20'5"	20'5"	20'5"	20'7"	20'7"	20'5"	20'7"	20'7"
Static tipping load straight	kg	11 960	11 637	11 636	11 818	11 491	11 491	11 923	11 599	11 599
	lb	26,367	25,655	25,653	26,054	25,333	25,333	26,286	25,571	25,571
Static tipping load with 40° turn	kg	10 164	9870	9866	10 025	9727	9723	10 128	9833	9829
	lb	22,408	21,760	21,751	22,101	21,444	21,436	22,328	21,678	21,669
Breakout force	kg	11 750	10 331	10 281	11 639	10 219	10 170	12 340	10 780	10 728
	lb	25,904	22,776	22,666	25,660	22,529	22,421	27,205	23,766	23,651
Operating weight	kg	16 028	16 347	16 394	16 319	16 458	16 505	16 236	16 376	16 423
	lb	35,336	36,039	36,143	35,977	36,284	36,387	35,794	36,103	36,206

*Meets Tier 4 Final/Stage IV/Japan 2014 (Tier 4 Final) emission standards.

NOTE: Specifications and ratings conform to all applicable standards recommended by the Society of Automotive Engineers (SAE), including SAE Standards J732 (APR07) which governs loader ratings.

	Change in Operating Weight		Change in Articulated Static Tipping Load	
	kg	lb	kg	lb
Without Ride Control System	- 31	- 68	- 14	- 31
Without Guard, driveshaft	- 44	- 97	- 13	- 29
With Guard, windshield	34	75	20	44
Without Rounding Fenders	- 41	- 90	- 31	- 68
Without Secondary Steering	- 53	- 117	- 53	- 117
Without Guard, crankcase	- 11	- 24	- 15	- 34
Without Guard, power train	- 67	- 148	- 64	- 142
With Guard, power train side	11	24	10	22
Without Counterweight, Heavy	- 343	- 756	- 570	- 1256
With Counterweight, Logger	299	658	402	886
With Cold Start 120V	54	119	92	202
With Product Link	8	18	8	18
With Guard, rear wastegate	276	608	516	1137
Tires, 3-piece rims				
20.5-25, 16PR (L-3)	- 104	- 229	- 126	- 278
20.5-25, 16PR (L-5)	224	494	272	600
550/65 R25, Radial (L-3)	- 108	- 238	- 131	- 289
600/65 R25, Radial (L-3)	24	53	29	64
20.5 R25, Radial (L-5) XMINE D2	616	1358	749	1651
20.5 R25, Radial (L-2) VUT	- 188	- 414	- 228	- 503
20.5 R25, Radial (L-3) VJT	32	71	39	86
20.5 R25, Radial (L-3) VMT	44	97	53	117
20.5 R25, Radial (L-5) VSDL	792	1746	962	2121

Bucket Type		General Purpose								
		Bolt-on Cutting Edges			Bolt-on Teeth & Segments			Bolt-on Teeth		
Ground Engaging Type										
Rated bucket capacity	m ³	2.50	2.70	2.90	2.50	2.70	2.90	2.40	2.60	2.80
	yd ³	3.27	3.53	3.79	3.27	3.53	3.79	3.14	3.40	3.66
Struck capacity	m ³	2.30	2.50	2.70	2.30	2.50	2.70	2.20	2.40	2.60
	yd ³	3.01	3.27	3.53	3.01	3.27	3.53	2.88	3.14	3.40
Bucket width	mm	2750	2750	2750	2750	2750	2750	2750	2750	2750
	ft/in	9'0"	9'0"	9'0"	9'0"	9'0"	9'0"	9'0"	9'0"	9'0"
Dump clearance at full lift and 45° discharge	mm	3450	3403	3367	3344	3297	3260	3344	3297	3260
	ft/in	11'4"	11'2"	11'1"	11'0"	10'10"	10'8"	11'0"	10'10"	10'8"
Reach at full lift and 45° discharge	mm	1374	1413	1444	1476	1514	1545	1476	1514	1545
	ft/in	4'6"	4'8"	4'9"	4'10"	5'0"	5'1"	4'10"	5'0"	5'1"
Reach at 45° discharge and 2130 mm (7'0") clearance	mm	2298	2319	2335	2357	2375	2389	2357	2375	2389
	ft/in	7'6"	7'7"	7'8"	7'9"	7'10"	7'10"	7'9"	7'10"	7'10"
Reach with lift arms horizontal and bucket level	mm	3059	3121	3170	3205	3267	3316	3205	3267	3316
	ft/in	10'0"	10'3"	10'5"	10'6"	10'9"	10'11"	10'6"	10'9"	10'11"
Digging depth	mm	135	135	135	146	146	146	146	146	146
	in	5.3	5.3	5.3	5.7	5.7	5.7	5.7	5.7	5.7
Overall length	mm	8344	8406	8455	8490	8552	8601	8475	8537	8586
	ft/in	27'5"	27'7"	27'9"	27'10"	28'1"	28'3"	27'10"	28'0"	28'2"
Overall height with bucket at full raise	mm	5823	5881	5929	5823	5881	5929	5823	5881	5929
	ft/in	19'1"	19'4"	19'5"	19'1"	19'4"	19'5"	19'1"	19'4"	19'5"
Loader clearance radius with bucket in carry position	mm	6472	6493	6509	6525	6546	6563	6525	6546	6563
	ft/in	21'3"	21'4"	21'4"	21'5"	21'6"	21'6"	21'5"	21'6"	21'6"
Static tipping load straight	kg	8714	8637	8574	8582	8505	8440	8680	8603	8540
	lb	19,211	19,041	18,902	18,920	18,750	18,607	19,136	18,966	18,827
Static tipping load with 40° turn	kg	7372	7301	7242	7243	7171	7111	7338	7267	7208
	lb	16,252	16,096	15,966	15,968	15,809	15,677	16,178	16,021	15,891
Breakout force	kg	13 284	12 580	12 069	13 173	12 468	11 957	14 075	13 285	12 714
	lb	29,286	27,734	26,608	29,042	27,487	26,361	31,030	29,289	28,030
Operating weight	kg	15 899	15 944	15 981	16 010	16 055	16 091	15 928	15 973	16 009
	lb	35,051	35,150	35,232	35,296	35,395	35,475	35,115	35,214	35,294

*Meets Tier 4 Final/Stage IV/Japan 2014 (Tier 4 Final) emission standards.

NOTE: Specifications and ratings conform to all applicable standards recommended by the Society of Automotive Engineers (SAE), including SAE Standards J732 (APR07) which governs loader ratings.

Wheel Loaders Integrated Toolcarriers

Performance Data ● 938M* High Lift Pin On Bucket

Bucket Type	Light Material									
	Ground Engaging Type	Bolt-on Cutting Edges			Bolt-on Teeth & Segments			Bolt-on Teeth		
Rated bucket capacity		m ³	3.50	4.20	5.00	3.50	4.20	5.00	3.40	4.10
	yd ³	4.58	5.49	6.54	4.58	5.49	6.54	4.45	5.36	6.41
Struck capacity	m ³	3.30	4.00	4.80	3.30	4.00	4.80	3.20	3.90	4.70
	yd ³	4.32	5.23	6.28	4.32	5.23	6.28	4.19	5.10	6.15
Bucket width	mm	2750	2750	2750	2750	2750	2750	2750	2750	2750
	ft/in	9'0"	9'0"	9'0"	9'0"	9'0"	9'0"	9'0"	9'0"	9'0"
Dump clearance at full lift and 45° discharge	mm	3272	3152	3152	3161	3040	3040	3161	3040	3040
	ft/in	10'9"	10'4"	10'4"	10'4"	10'0"	10'0"	10'4"	10'0"	10'0"
Reach at full lift and 45° discharge	mm	1440	1561	1561	1536	1656	1656	1536	1656	1656
	ft/in	4'9"	5'1"	5'1"	5'0"	5'5"	5'5"	5'0"	5'5"	5'5"
Reach at 45° discharge and 2130 mm (7'0") clearance	mm	2290	2353	2353	2332	2390	2390	2332	2390	2390
	ft/in	7'6"	7'9"	7'9"	7'8"	7'10"	7'10"	7'8"	7'10"	7'10"
Reach with lift arms horizontal and bucket level	mm	3249	3419	3419	3395	3565	3565	3395	3565	3565
	ft/in	10'8"	11'3"	11'3"	11'2"	11'8"	11'8"	11'2"	11'8"	11'8"
Digging depth	mm	135	135	135	146	146	146	146	146	146
	in	5.3	5.3	5.3	5.7	5.7	5.7	5.7	5.7	5.7
Overall length	mm	8534	8704	8704	8680	8850	8850	8665	8835	8835
	ft/in	28'0"	28'7"	28'7"	28'6"	29'0"	29'0"	28'5"	29'0"	29'0"
Overall height with bucket at full raise	mm	5926	6087	6367	5926	6087	6367	5926	6087	6367
	ft/in	19'5"	20'0"	20'11"	19'5"	20'0"	20'11"	19'5"	20'0"	20'11"
Loader clearance radius with bucket in carry position	mm	6536	6594	6594	6590	6649	6649	6590	6649	6649
	ft/in	21'5"	21'8"	21'8"	21'7"	21'10"	21'10"	21'7"	21'10"	21'10"
Static tipping load straight	kg	8409	8165	8148	8275	8028	8010	8375	8129	8118
	lb	18,539	18,001	17,963	18,243	17,699	17,659	18,464	17,921	17,897
Static tipping load with 40° turn	kg	7087	6861	6842	6955	6726	6708	7053	6826	6808
	lb	15,624	15,126	15,084	15,333	14,828	14,789	15,549	15,049	15,009
Breakout force	kg	11 295	9925	9875	11 183	9814	9764	11 857	10 352	10 300
	lb	24,901	21,881	21,771	24,654	21,636	21,526	26,140	22,822	22,708
Operating weight	kg	16 106	16 245	16 292	16 217	16 356	16 043	16 134	16 274	16 321
	lb	35,508	35,814	35,918	35,752	36,059	35,369	35,569	35,878	35,982

*Meets Tier 4 Final/Stage IV/Japan 2014 (Tier 4 Final) emission standards.

NOTE: Specifications and ratings conform to all applicable standards recommended by the Society of Automotive Engineers (SAE), including SAE Standards J732 (APR07) which governs loader ratings.

	Change in Operating Weight		Change in Articulated Static Tipping Load	
	kg	lb	kg	lb
Without Ride Control System	- 31	- 68	- 11	- 24
Without Guard, driveshaft	- 44	- 97	- 10	- 23
With Guard, windshield	34	75	16	34
Without Roading Fenders	- 41	- 90	- 24	- 54
Without Secondary Steering	- 53	- 117	- 42	- 92
Without Guard, crankcase	- 11	- 24	- 12	- 26
Without Guard, power train	- 67	- 148	- 50	- 111
With Guard, power train side	11	24	8	17
Without Counterweight, Heavy	- 343	- 756	- 447	- 985
With Counterweight, Logger	N/A	N/A	N/A	N/A
With Cold Start 120V	54	119	72	159
With Product Link	8	18	6	14
With Guard, rear wastegate	276	608	404	891
Tires, 3-piece rims				
20.5-25, 16PR (L-3)	- 104	- 229	- 99	- 218
20.5-25, 16PR (L-5)	224	494	213	470
550/65 R25, Radial (L-3)	- 108	- 238	- 103	- 227
600/65 R25, Radial (L-3)	24	53	23	51
20.5 R25, Radial (L-5) XMINE D2	616	1358	587	1294
20.5 R25, Radial (L-2) VUT	- 188	- 414	- 179	- 395
20.5 R25, Radial (L-3) VJT	32	71	30	66
20.5 R25, Radial (L-3) VMT	44	97	42	93
20.5 R25, Radial (L-5) VSDL	792	1746	755	1664

Bucket Type		General Purpose								
		Bolt-on Cutting Edges			Bolt-on Teeth & Segments			Bolt-on Teeth		
Ground Engaging Type										
Rated bucket capacity	m ³	2.50	2.70	2.90	2.50	2.70	2.90	2.40	2.60	2.80
	yd ³	3.27	3.53	3.79	3.27	3.53	3.79	3.14	3.40	3.66
Struck capacity	m ³	2.30	2.50	2.70	2.30	2.50	2.70	2.20	2.40	2.60
	yd ³	3.01	3.27	3.53	3.01	3.27	3.53	2.88	3.14	3.40
Bucket width	mm	2750	2750	2750	2750	2750	2750	2750	2750	2750
	ft/in	9'0"	9'0"	9'0"	9'0"	9'0"	9'0"	9'0"	9'0"	9'0"
Dump clearance at full lift and 45° discharge	mm	2834	2787	2751	2729	2681	2644	2729	2681	2644
	ft/in	9'4"	9'2"	9'0"	8'11"	8'10"	8'8"	8'11"	8'10"	8'8"
Reach at full lift and 45° discharge	mm	1146	1185	1216	1248	1286	1316	1248	1286	1316
	ft/in	3'9"	3'11"	4'0"	4'1"	4'3"	4'4"	4'1"	4'3"	4'4"
Reach at 45° discharge and 2130 mm (7'0") clearance	mm	1658	1672	1684	1704	1714	1723	1704	1714	1723
	ft/in	5'5"	5'6"	5'6"	5'7"	5'7"	5'8"	5'7"	5'7"	5'8"
Reach with lift arms horizontal and bucket level	mm	2504	2566	2615	2650	2712	2761	2650	2712	2761
	ft/in	8'3"	8'5"	8'7"	8'8"	8'11"	9'1"	8'8"	8'11"	9'1"
Digging depth	mm	101	101	101	112	112	112	112	112	112
	in	4.0	4.0	4.0	4.4	4.4	4.4	4.4	4.4	4.4
Overall length	mm	7656	7718	7767	7802	7864	7913	7782	7844	7893
	ft/in	25'1"	25'4"	25'6"	25'7"	25'10"	26'0"	25'6"	25'9"	25'11"
Overall height with bucket at full raise	mm	5273	5332	5379	5273	5332	5379	5273	5332	5379
	ft/in	17'4"	17'6"	17'8"	17'4"	17'6"	17'8"	17'4"	17'6"	17'8"
Loader clearance radius with bucket in carry position	mm	6133	6152	6166	6181	6200	6215	6181	6200	6215
	ft/in	20'1"	20'2"	20'3"	20'3"	20'4"	20'5"	20'3"	20'4"	20'5"
Static tipping load straight	kg	11 820	11 721	11 641	11 682	11 582	11 500	11 784	11 685	11 604
	lb	26,059	25,840	25,664	25,754	25,534	25,353	25,979	25,761	25,582
Static tipping load with 40° turn	kg	10 028	9938	9864	9893	9802	9727	9993	9903	9829
	lb	22,108	21,910	21,746	21,810	21,610	21,444	22,031	21,832	21,669
Breakout force	kg	13 170	12 498	12 009	13 059	12 387	11 897	13 920	13 170	12 626
	lb	29,035	27,554	26,475	28,790	27,309	26,229	30,689	29,035	27,836
Operating weight	kg	16 427	16 472	16 508	16 538	16 583	16 619	16 456	16 500	16 536
	lb	36,215	36,315	36,394	36,460	36,559	36,639	36,279	36,376	36,456

*Meets Tier 4 Final/Stage IV/Japan 2014 (Tier 4 Final) emission standards.

NOTE: Specifications and ratings conform to all applicable standards recommended by the Society of Automotive Engineers (SAE), including SAE Standards J732 (APR07) which governs loader ratings.

Wheel Loaders Integrated Toolcarriers

Performance Data ● 938M* Standard Lift Fusion Bucket

Bucket Type	Light Material									
	Ground Engaging Type	Bolt-on Cutting Edges			Bolt-on Teeth & Segments			Bolt-on Teeth		
Rated bucket capacity		m ³	3.50	4.20	5.00	3.50	4.20	5.00	3.40	4.10
	yd ³	4.58	5.49	6.54	4.58	5.49	6.54	4.45	5.36	6.41
Struck capacity	m ³	3.30	4.00	4.80	3.30	4.00	4.80	3.20	3.90	4.70
	yd ³	4.32	5.23	6.28	4.32	5.23	6.28	4.19	5.10	6.15
Bucket width	mm	2750	2750	2750	2750	2750	2750	2750	2750	2750
	ft/in	9'0"	9'0"	9'0"	9'0"	9'0"	9'0"	9'0"	9'0"	9'0"
Dump clearance at full lift and 45° discharge	mm	2654	2534	2534	2543	2422	2422	2543	2422	2422
	ft/in	8'8"	8'4"	8'4"	8'4"	7'11"	7'11"	8'4"	7'11"	7'11"
Reach at full lift and 45° discharge	mm	1210	1331	1331	1305	1426	1426	1305	1426	1426
	ft/in	4'0"	4'4"	4'4"	4'3"	4'8"	4'8"	4'3"	4'8"	4'8"
Reach at 45° discharge and 2130 mm (7'0") clearance	mm	1622	1666	1666	1646	1681	1681	1646	1681	1681
	ft/in	5'4"	5'6"	5'6"	5'5"	5'6"	5'6"	5'5"	5'6"	5'6"
Reach with lift arms horizontal and bucket level	mm	2694	2864	2864	2840	3010	3010	2840	3010	3010
	ft/in	8'10"	9'5"	9'5"	9'4"	9'11"	9'11"	9'11"	9'11"	9'11"
Digging depth	mm	101	101	101	112	112	112	112	112	112
	in	4.0	4.0	4.0	4.4	4.4	4.4	4.4	4.4	4.4
Overall length	mm	7846	8016	8016	7992	8162	8162	7972	8142	8142
	ft/in	25'9"	26'4"	26'4"	26'3"	26'9"	26'9"	26'2"	26'9"	26'9"
Overall height with bucket at full raise	mm	5376	5539	5820	5376	5539	5820	5376	5539	5820
	ft/in	17'8"	18'2"	19'1"	17'8"	18'2"	19'1"	17'8"	18'2"	19'1"
Loader clearance radius with bucket in carry position	mm	6190	6244	6244	6240	6295	6295	6240	6295	6295
	ft/in	20'4"	20'6"	20'6"	20'6"	20'8"	20'8"	20'6"	20'8"	20'8"
Static tipping load straight	kg	11 451	11 151	11 120	11 309	11 006	10 975	11 414	11 113	11 083
	lb	25,245	24,584	24,515	24,932	24,264	24,196	25,164	24,500	24,434
Static tipping load with 40° turn	kg	9689	9416	9383	9550	9275	9241	9653	9380	9347
	lb	21,361	20,759	20,686	21,054	20,448	20,373	21,281	20,679	20,607
Breakout force	kg	11 263	9936	9888	11 151	9825	9776	11 803	10 351	10 300
	lb	24,831	21,905	21,799	24,584	21,661	21,553	26,021	22,820	22,708
Operating weight	kg	16 628	16 757	16 835	16 379	16 868	16 946	16 656	16 786	16 864
	lb	36,658	36,943	37,115	36,109	37,188	37,359	36,720	37,007	37,179

*Meets Tier 4 Final/Stage IV/Japan 2014 (Tier 4 Final) emission standards.

NOTE: Specifications and ratings conform to all applicable standards recommended by the Society of Automotive Engineers (SAE), including SAE Standards J732 (APR07) which governs loader ratings.

	Change in Operating Weight		Change in Articulated Static Tipping Load	
	kg	lb	kg	lb
Without Ride Control System	- 31	- 68	- 14	- 30
Without Guard, driveshaft	- 44	- 97	- 13	- 29
With Guard, windshield	34	75	20	43
Without Roading Fenders	- 41	- 90	- 30	- 67
Without Secondary Steering	- 53	- 117	- 52	- 115
Without Guard, crankcase	- 11	- 24	- 15	- 33
Without Guard, power train	- 67	- 148	- 63	- 140
With Guard, power train side	11	24	10	21
Without Counterweight, Heavy	- 343	- 756	- 561	- 1236
With Counterweight, Logger	299	658	402	886
With Cold Start 120V	54	119	90	199
With Product Link	8	18	8	17
With Guard, rear wastegate	276	608	508	1119
Tires, 3-piece rims				
20.5-25, 16PR (L-3)	- 104	- 229	- 124	- 273
20.5-25, 16PR (L-5)	224	494	268	591
550/65 R25, Radial (L-3)	- 108	- 238	- 129	- 284
600/65 R25, Radial (L-3)	24	53	29	64
20.5 R25, Radial (L-5) XMINE D2	616	1358	737	1625
20.5 R25, Radial (L-2) VUT	- 188	- 414	- 225	- 496
20.5 R25, Radial (L-3) VJT	32	71	38	84
20.5 R25, Radial (L-3) VMT	44	97	53	117
20.5 R25, Radial (L-5) VSDL	792	1746	948	2090

Bucket Type		General Purpose								
		Bolt-on Cutting Edges			Bolt-on Teeth & Segments			Bolt-on Teeth		
Ground Engaging Type										
Rated bucket capacity	m ³	2.50	2.70	2.90	2.50	2.70	2.90	2.40	2.60	2.80
	yd ³	3.27	3.53	3.79	3.27	3.53	3.79	3.14	3.40	3.66
Struck capacity	m ³	2.30	2.50	2.70	2.30	2.50	2.70	2.20	2.40	2.60
	yd ³	3.01	3.27	3.53	3.01	3.27	3.53	2.88	3.14	3.40
Bucket width	mm	2750	2750	2750	2750	2750	2750	2750	2750	2750
	ft/in	9'0"	9'0"	9'0"	9'0"	9'0"	9'0"	9'0"	9'0"	9'0"
Dump clearance at full lift and 45° discharge	mm	3415	3368	3332	3310	3262	3225	3310	3262	3225
	ft/in	11'2"	11'1"	10'11"	10'10"	10'8"	10'7"	10'10"	10'8"	10'7"
Reach at full lift and 45° discharge	mm	1413	1451	1482	1515	1552	1583	1515	1552	1583
	ft/in	4'8"	4'9"	4'10"	5'0"	5'1"	5'2"	5'0"	5'1"	5'2"
Reach at 45° discharge and 2130 mm (7'0") clearance	mm	2323	2343	2358	2381	2398	2411	2381	2398	2411
	ft/in	7'7"	7'8"	7'9"	7'10"	7'10"	7'11"	7'10"	7'10"	7'11"
Reach with lift arms horizontal and bucket level	mm	3111	3173	3222	3257	3319	3368	3257	3319	3368
	ft/in	10'2"	10'5"	10'7"	10'8"	10'11"	11'1"	10'8"	10'11"	11'1"
Digging depth	mm	135	135	135	147	147	147	147	147	147
	in	5.3	5.3	5.3	5.8	5.8	5.8	5.8	5.8	5.8
Overall length	mm	8397	8459	8508	8543	8605	8654	8527	8589	8638
	ft/in	27'7"	27'9"	27'11"	28'0"	28'3"	28'5"	28'0"	28'2"	28'4"
Overall height with bucket at full raise	mm	5853	5912	5960	5853	5912	5960	5853	5912	5960
	ft/in	19'2"	19'5"	19'7"	19'2"	19'5"	19'7"	19'2"	19'5"	19'7"
Loader clearance radius with bucket in carry position	mm	6490	6511	6527	6544	6565	6582	6544	6565	6582
	ft/in	21'4"	21'4"	21'5"	21'6"	21'6"	21'7"	21'6"	21'6"	21'7"
Static tipping load straight	kg	8257	8182	8121	8126	8050	7988	8223	8148	8086
	lb	18,204	18,038	17,904	17,915	17,747	17,611	18,129	17,963	17,827
Static tipping load with 40° turn	kg	6939	6869	6812	6810	6740	6682	6906	6836	6779
	lb	15,298	15,144	15,018	15,013	14,859	14,731	15,225	15,071	14,945
Breakout force	kg	12 663	12 015	11 543	12 552	11 904	11 432	13 379	12 656	12 132
	lb	27,917	26,489	25,448	27,673	26,244	25,203	29,496	27,902	26,747
Operating weight	kg	16 326	16 370	16 406	16 436	16 481	16 517	16 354	16 398	16 435
	lb	35,993	36,090	36,169	36,235	36,334	36,414	36,054	36,151	36,233

*Meets Tier 4 Final/Stage IV/Japan 2014 (Tier 4 Final) emission standards.

NOTE: Specifications and ratings conform to all applicable standards recommended by the Society of Automotive Engineers (SAE), including SAE Standards J732 (APR07) which governs loader ratings.

Wheel Loaders Integrated Toolcarriers

Performance Data ● 938M* High Lift Fusion Bucket

Bucket Type	Ground Engaging Type	Light Material								
		Bolt-on Cutting Edges			Bolt-on Teeth & Segments			Bolt-on Teeth		
Rated bucket capacity	m ³	3.50	4.20	5.00	3.50	4.20	5.00	3.40	4.10	4.90
	yd ³	4.58	5.49	6.54	4.58	5.49	6.54	4.45	5.36	6.41
Struck capacity	m ³	3.30	4.00	4.80	3.30	4.00	4.80	3.20	3.90	4.70
	yd ³	4.32	5.23	6.28	4.32	5.23	6.28	4.19	5.10	6.15
Bucket width	mm	2750	2750	2750	2750	2750	2750	2750	2750	2750
	ft/in	9'0"	9'0"	9'0"	9'0"	9'0"	9'0"	9'0"	9'0"	9'0"
Dump clearance at full lift and 45° discharge	mm	3235	3115	3115	3124	3003	3003	3124	3003	3003
	ft/in	10'7"	10'3"	10'3"	10'3"	9'10"	9'10"	10'3"	9'10"	9'10"
Reach at full lift and 45° discharge	mm	1477	1597	1597	1572	1692	1692	1572	1692	1692
	ft/in	4'10"	5'3"	5'3"	5'2"	5'7"	5'7"	5'2"	5'7"	5'7"
Reach at 45° discharge and 2130 mm (7'0") clearance	mm	2310	2371	2371	2350	2406	2406	2350	2406	2406
	ft/in	7'7"	7'9"	7'9"	7'9"	7'11"	7'11"	7'9"	7'11"	7'11"
Reach with lift arms horizontal and bucket level	mm	3301	3471	3471	3447	3617	3617	3447	3617	3617
	ft/in	10'10"	11'5"	11'5"	11'4"	11'10"	11'10"	11'4"	11'10"	11'10"
Digging depth	mm	135	135	135	147	147	147	147	147	147
	in	5.3	5.3	5.3	5.8	5.8	5.8	5.8	5.8	5.8
Overall length	mm	8587	8757	8757	8733	8903	8903	8717	8887	8887
	ft/in	28'2"	28'9"	28'9"	28'8"	29'2"	29'2"	28'7"	29'2"	29'2"
Overall height with bucket at full raise	mm	5957	6120	6401	5957	6120	6401	5957	6120	6401
	ft/in	19'7"	20'1"	21'0"	19'7"	20'1"	21'0"	19'7"	20'1"	21'0"
Loader clearance radius with bucket in carry position	mm	6554	6613	6613	6609	6669	6669	6609	6669	6669
	ft/in	21'6"	21'8"	21'8"	21'8"	21'11"	21'11"	21'8"	21'11"	21'11"
Static tipping load straight	kg	7965	7739	7693	7831	7602	7556	7930	7704	7657
	lb	17,560	17,062	16,960	17,264	16,760	16,658	17,483	16,984	16,881
Static tipping load with 40° turn	kg	6666	6457	6410	6534	6323	6276	6632	6423	6376
	lb	14,696	14,235	14,132	14,405	13,940	13,836	14,621	14,160	14,057
Breakout force	kg	10 823	9543	9495	10 711	9432	9383	11 337	9937	9886
	lb	23,861	21,039	20,933	23,614	20,794	20,686	24,994	21,907	21,795
Operating weight	kg	16 526	16 656	16 733	16 637	16 766	16 844	16 554	16 684	16 762
	lb	36,434	36,720	36,890	36,678	36,963	37,135	36,495	36,782	36,954

*Meets Tier 4 Final/Stage IV/Japan 2014 (Tier 4 Final) emission standards.

NOTE: Specifications and ratings conform to all applicable standards recommended by the Society of Automotive Engineers (SAE), including SAE Standards J732 (APR07) which governs loader ratings.

	Change in Operating Weight		Change in Articulated Static Tipping Load	
	kg	lb	kg	lb
Without Ride Control System	- 31	- 68	- 11	- 24
Without Guard, driveshaft	- 44	- 97	- 10	- 23
With Guard, windshield	34	75	15	34
Without Roading Fenders	- 41	- 90	- 24	- 53
Without Secondary Steering	- 53	- 117	- 41	- 91
Without Guard, crankcase	- 11	- 24	- 12	- 26
Without Guard, power train	- 67	- 148	- 50	- 110
With Guard, power train side	11	24	8	17
Without Counterweight, Heavy	- 343	- 756	- 441	- 973
With Counterweight, Logger	N/A	N/A	N/A	N/A
With Cold Start 120V	54	119	71	157
With Product Link	8	18	6	14
With Guard, rear wastegate	276	608	399	881
Tires, 3-piece rims				
20.5-25, 16PR (L-3)	- 104	- 229	- 98	- 216
20.5-25, 16PR (L-5)	224	494	211	465
550/65 R25, Radial (L-3)	- 108	- 238	- 102	- 225
600/65 R25, Radial (L-3)	24	53	23	51
20.5 R25, Radial (L-5) XMINE D2	616	1358	580	1279
20.5 R25, Radial (L-2) VUT	- 188	- 414	- 177	- 390
20.5 R25, Radial (L-3) VJT	32	71	30	66
20.5 R25, Radial (L-3) VMT	44	97	41	90
20.5 R25, Radial (L-5) VSDL	792	1746	746	1645

Bucket Type Ground Engaging Type		General Purpose							
		Bolt-on Cutting Edges				Bolt-on Teeth & Segments			
Rated bucket capacity	m ³	2.10	2.30	2.70	2.90	2.10	2.30	2.70	2.90
	yd ³	2.75	3.01	3.53	3.79	2.75	3.01	3.53	3.79
Struck capacity	m ³	2.00	2.20	2.60	2.70	2.00	2.20	2.60	2.70
	yd ³	2.62	2.88	3.40	3.53	2.62	2.88	3.40	3.53
Bucket width	mm	2550	2550	2750	2750	2550	2550	2750	2750
	ft/in	8'4"	8'4"	9'0"	9'0"	8'4"	8'4"	9'0"	9'0"
Dump clearance at full lift and 45° discharge	mm	2809	2760	2712	2675	2704	2654	2606	2569
	ft/in	9'3"	9'1"	8'11"	8'9"	8'10"	8'8"	8'7"	8'5"
Reach at full lift and 45° discharge	mm	1206	1242	1280	1311	1308	1344	1381	1411
	ft/in	3'11"	4'1"	4'2"	4'4"	4'3"	4'5"	4'6"	4'8"
Reach at 45° discharge and 2130 mm (7'0") clearance	mm	1704	1715	1726	1735	1750	1756	1763	1770
	ft/in	5'7"	5'8"	5'8"	5'8"	5'9"	5'9"	5'9"	5'10"
Reach with lift arms horizontal and bucket level	mm	2562	2625	2687	2736	2708	2771	2833	2882
	ft/in	8'5"	8'7"	8'10"	9'0"	8'11"	9'1"	9'4"	9'5"
Digging depth	mm	93	93	93	93	105	105	105	105
	in	3.7	3.7	3.7	3.7	4.1	4.1	4.1	4.1
Overall length	mm	7708	7771	7833	7882	7854	7917	7979	8028
	ft/in	25'3"	25'6"	25'8"	25'10"	25'9"	26'0"	26'2"	26'4"
Overall height with bucket at full raise	mm	5298	5356	5415	5462	5298	5356	5415	5462
	ft/in	17'5"	17'7"	17'9"	17'11"	17'5"	17'7"	17'9"	17'11"
Loader clearance radius with bucket in carry position	mm	6039	6059	6169	6185	6090	6110	6221	6237
	ft/in	19'10"	19'11"	20'3"	20'4"	20'0"	20'1"	20'5"	20'6"
Static tipping load straight	kg	11 536	11 446	11 245	11 171	11 389	11 298	11 107	11 032
	lb	25,432	25,234	24,791	24,628	25,108	24,908	24,487	24,321
Static tipping load with 40° turn	kg	9809	9727	9536	9469	9665	9581	9401	9332
	lb	21,625	21,444	21,023	20,876	21,308	21,122	20,726	20,574
Breakout force	kg	12 542	11 922	11 299	10 887	12 422	11 802	11 187	10 775
	lb	27,651	26,284	24,910	24,002	27,386	26,019	24,663	23,755
Operating weight	kg	16 175	16 213	16 367	16 401	16 295	16 333	16 478	16 512
	lb	35,660	35,744	36,083	36,158	35,924	36,008	36,328	36,403

*Meets Tier 4 Final/Stage IV/Japan 2014 (Tier 4 Final) emission standards.

NOTE: Specifications and ratings conform to all applicable standards recommended by the Society of Automotive Engineers (SAE), including SAE Standards J732 (APR07) which governs loader ratings.

Wheel Loaders Integrated Toolcarriers

Performance Data ● 938M* Standard Lift ISO Bucket

Bucket Type		General Purpose			
Ground Engaging Type		Bolt-on Teeth			
Rated bucket capacity	m ³	2.00	2.20	2.60	2.80
	yd ³	2.62	2.88	3.40	3.66
Struck capacity	m ³	1.90	2.10	2.50	2.60
	yd ³	2.49	2.75	3.27	3.40
Bucket width	mm	2550	2550	2750	2750
	ft/in	8'4"	8'4"	9'0"	9'0"
Dump clearance at full lift and 45° discharge	mm	2704	2654	2606	2569
	ft/in	8'10"	8'8"	8'7"	8'5"
Reach at full lift and 45° discharge	mm	1308	1344	1381	1411
	ft/in	4'3"	4'5"	4'6"	4'8"
Reach at 45° discharge and 2130 mm (7'0") clearance	mm	1750	1756	1763	1770
	ft/in	5'9"	5'9"	5'9"	5'10"
Reach with lift arms horizontal and bucket level	mm	2708	2771	2833	2882
	ft/in	8'11"	9'1"	9'4"	9'5"
Digging depth	mm	105	105	105	105
	in	4.1	4.1	4.1	4.1
Overall length	mm	7833	7896	7958	8007
	ft/in	25'8"	25'11"	26'1"	26'3"
Overall height with bucket at full raise	mm	5298	5356	5415	5462
	ft/in	17'5"	17'7"	17'9"	17'11"
Loader clearance radius with bucket in carry position	mm	6090	6110	6221	6237
	ft/in	20'0"	20'1"	20'5"	20'6"
Static tipping load straight	kg	11 490	11 399	11 210	11 135
	lb	25,331	25,130	24,714	24,548
Static tipping load with 40° turn	kg	9763	9681	9502	9433
	lb	21,524	21,343	20,948	20,796
Breakout force	kg	13 206	12 517	11 841	11 387
	lb	29,114	27,595	26,105	25,104
Operating weight	kg	16 213	16 251	16 396	16 430
	lb	35,744	35,827	36,147	36,222

*Meets Tier 4 Final/Stage IV/Japan 2014 (Tier 4 Final) emission standards.

NOTE: Specifications and ratings conform to all applicable standards recommended by the Society of Automotive Engineers (SAE), including SAE Standards J732 (APR07) which governs loader ratings.

	Change in Operating Weight		Change in Articulated Static Tipping Load	
	kg	lb	kg	lb
Without Ride Control System	- 31	- 68	- 13	- 29
Without Guard, driveshaft	- 44	- 97	- 13	- 28
With Guard, windshield	34	75	19	42
Without Rooding Fenders	- 41	- 90	- 29	- 65
Without Secondary Steering	- 53	- 117	- 51	- 112
Without Guard, crankcase	- 11	- 24	- 14	- 32
Without Guard, power train	- 67	- 148	- 61	- 135
With Guard, power train side	11	24	9	21
Without Counterweight, Heavy	- 343	- 756	- 542	- 1195
With Counterweight, Logger	299	658	402	886
With Cold Start 120V	54	119	87	192
With Product Link	8	18	8	17
With Guard, rear wastegate	276	608	491	1082
Tires, 3-piece rims				
20.5-25, 16PR (L-3)	- 104	- 229	- 120	- 265
20.5-25, 16PR (L-5)	224	494	259	571
550/65 R25, Radial (L-3)	- 108	- 238	- 125	- 276
600/65 R25, Radial (L-3)	24	53	28	62
20.5 R25, Radial (L-5) XMINE D2	616	1358	712	1570
20.5 R25, Radial (L-2) VUT	- 188	- 414	- 217	- 478
20.5 R25, Radial (L-3) VJT	32	71	37	82
20.5 R25, Radial (L-3) VMT	44	97	51	112
20.5 R25, Radial (L-5) VSDL	792	1746	916	2019

Bucket Type	Ground Engaging Type	General Purpose							
		Bolt-on Cutting Edges				Bolt-on Teeth & Segments			
Rated bucket capacity	m ³	2.10	2.30	2.70	2.90	2.10	2.30	2.70	2.90
	yd ³	2.75	3.01	3.53	3.79	2.75	3.01	3.53	3.79
Struck capacity	m ³	2.00	2.20	2.60	2.70	2.00	2.20	2.60	2.70
	yd ³	2.62	2.88	3.40	3.53	2.62	2.88	3.40	3.53
Bucket width	mm	2550	2550	2750	2750	2550	2550	2750	2750
	ft/in	8'4"	8'4"	9'0"	9'0"	8'4"	8'4"	9'0"	9'0"
Dump clearance at full lift and 45° discharge	mm	3390	3340	3293	3256	3285	3235	3187	3150
	ft/in	11'1"	10'11"	10'10"	10'8"	10'9"	10'7"	10'5"	10'4"
Reach at full lift and 45° discharge	mm	1472	1509	1547	1577	1575	1611	1648	1678
	ft/in	4'10"	4'11"	5'1"	5'2"	5'2"	5'3"	5'5"	5'6"
Reach at 45° discharge and 2130 mm (7'0") clearance	mm	2372	2389	2406	2420	2430	2443	2458	2469
	ft/in	7'9"	7'10"	7'11"	7'11"	8'0"	8'0"	8'1"	8'1"
Reach with lift arms horizontal and bucket level	mm	3169	3232	3294	3343	3315	3378	3440	3489
	ft/in	10'5"	10'7"	10'10"	11'0"	10'11"	11'1"	11'3"	11'5"
Digging depth	mm	128	128	128	128	139	139	139	139
	in	5.0	5.0	5.0	5.0	5.5	5.5	5.5	5.5
Overall length	mm	8450	8513	8575	8624	8596	8659	8721	8770
	ft/in	27'9"	27'11"	28'2"	28'4"	28'2"	28'5"	28'7"	28'9"
Overall height with bucket at full raise	mm	5879	5937	5996	6043	5879	5937	5996	6043
	ft/in	19'3"	19'6"	19'8"	19'10"	19'3"	19'6"	19'8"	19'10"
Loader clearance radius with bucket in carry position	mm	6410	6433	6540	6558	6468	6491	6598	6616
	ft/in	21'0"	21'1"	21'5"	21'6"	21'3"	21'4"	21'8"	21'8"
Static tipping load straight	kg	8188	8120	8144	8075	8144	8075	7907	7850
	lb	18,051	17,902	17,954	17,802	17,954	17,802	17,432	17,306
Static tipping load with 40° turn	kg	6906	6843	6862	6799	6862	6799	6638	6585
	lb	15,225	15,086	15,128	14,989	15,128	14,989	14,634	14,517
Breakout force	kg	12 052	11 455	10 852	10 454	11 932	11 334	10 740	10 343
	lb	26,570	25,254	23,925	23,047	26,306	24,987	23,678	22,803
Operating weight	kg	16 073	16 111	16 117	16 149	16 111	16 149	16 294	16 328
	lb	35,435	35,519	35,532	35,602	35,519	35,602	35,922	35,997

*Meets Tier 4 Final/Stage IV/Japan 2014 (Tier 4 Final) emission standards.

NOTE: Specifications and ratings conform to all applicable standards recommended by the Society of Automotive Engineers (SAE), including SAE Standards J732 (APR07) which governs loader ratings.

Wheel Loaders Integrated Toolcarriers

Performance Data ● 938M* High Lift ISO Bucket

Bucket Type		General Purpose			
Ground Engaging Type		Bolt-on Teeth			
Rated bucket capacity	m ³	2.00	2.20	2.60	2.80
	yd ³	2.62	2.88	3.40	3.66
Struck capacity	m ³	1.90	2.10	2.50	2.60
	yd ³	2.49	2.75	3.27	3.40
Bucket width	mm	2550	2550	2750	2750
	ft/in	8'4"	8'4"	9'0"	9'0"
Dump clearance at full lift and 45° discharge	mm	3285	3235	3187	3150
	ft/in	10'9"	10'7"	10'5"	10'4"
Reach at full lift and 45° discharge	mm	1575	1611	1648	1678
	ft/in	5'2"	5'3"	5'5"	5'6"
Reach at 45° discharge and 2130 mm (7'0") clearance	mm	2430	2443	2458	2469
	ft/in	8'0"	8'0"	8'1"	8'1"
Reach with lift arms horizontal and bucket level	mm	3315	3378	3440	3489
	ft/in	10'11"	11'1"	11'3"	11'5"
Digging depth	mm	139	139	139	139
	in	5.5	5.5	5.5	5.5
Overall length	mm	8581	8644	8706	8755
	ft/in	28'2"	28'4"	28'7"	28'9"
Overall height with bucket at full raise	mm	5879	5937	5996	6043
	ft/in	19'3"	19'6"	19'8"	19'10"
Loader clearance radius with bucket in carry position	mm	6468	6491	6598	6616
	ft/in	21'3"	21'4"	21'8"	21'8"
Static tipping load straight	kg	8144	8075	7907	7850
	lb	17,954	17,802	17,432	17,306
Static tipping load with 40° turn	kg	6862	6799	6638	6585
	lb	15,128	14,989	14,634	14,517
Breakout force	kg	12 686	12 022	11 369	10 932
	lb	27,968	26,504	25,064	24,101
Operating weight	kg	16 111	16 149	16 294	16 328
	lb	35,519	35,602	35,922	35,997

*Meets Tier 4 Final/Stage IV/Japan 2014 (Tier 4 Final) emission standards.

NOTE: Specifications and ratings conform to all applicable standards recommended by the Society of Automotive Engineers (SAE), including SAE Standards J732 (APR07) which governs loader ratings.

	Change in Operating Weight		Change in Articulated Static Tipping Load	
	kg	lb	kg	lb
Without Ride Control System	- 31	- 68	- 10	- 23
Without Guard, driveshaft	- 44	- 97	- 10	- 22
With Guard, windshield	34	75	15	33
Without Rooding Fenders	- 41	- 90	- 23	- 51
Without Secondary Steering	- 53	- 117	- 40	- 88
Without Guard, crankcase	- 11	- 24	- 11	- 25
Without Guard, power train	- 67	- 148	- 49	- 107
With Guard, power train side	11	24	7	16
Without Counterweight, Heavy	- 343	- 756	- 430	- 947
With Counterweight, Logger	N/A	N/A	N/A	N/A
With Cold Start 120V	54	119	69	153
With Product Link	8	18	6	13
With Guard, rear wastegate	276	608	389	857
Tires, 3-piece rims				
20.5-25, 16PR (L-3)	- 104	- 229	- 95	- 209
20.5-25, 16PR (L-5)	224	494	205	452
550/65 R25, Radial (L-3)	- 108	- 238	- 99	- 218
600/65 R25, Radial (L-3)	24	53	22	49
20.5 R25, Radial (L-5) XMINE D2	616	1358	564	1243
20.5 R25, Radial (L-2) VUT	- 188	- 414	- 172	- 379
20.5 R25, Radial (L-3) VJT	32	71	29	64
20.5 R25, Radial (L-3) VMT	44	97	40	88
20.5 R25, Radial (L-5) VSDL	792	1746	726	1601

- Performance Data
 ● 938M* Standard Lift
 ● Pallet Forks ● Construction Forks

Wheel Loaders Integrated Toolcarriers

		Pallet Forks – Fusion		
Fork tine length	mm	1220	1370	1524
	ft/in	4'0"	4'6"	5'0"
Ground to top of tine clearance	mm	3758	3758	3758
	ft/in	12'4"	12'4"	12'4"
Reach with lift arms horizontal and forks level	mm	1617	1617	1617
	ft/in	5'4"	5'4"	5'4"
Overall length	mm	7942	8092	8246
	ft/in	26'1"	26'7"	27'1"
Static tipping load with level arms and forks, straight	kg	9274	9022	8775
	lb	20,446	19,890	19,346
Static tipping load with level arms and forks, full 40° turn	kg	7909	7692	7478
	lb	17,436	16,958	16,486
Operating weight	kg	15 932	15 953	15 975
	lb	35,124	35,170	35,219

		Pallet Forks – ISO		
Fork tine length	mm	1220	1370	1524
	ft/in	4'0"	4'6"	5'0"
Ground to top of tine clearance	mm	3755	3755	3755
	ft/in	12'4"	12'4"	12'4"
Reach with lift arms horizontal and forks level	mm	1634	1634	1634
	ft/in	5'4"	5'4"	5'4"
Overall length	mm	7966	8116	8270
	ft/in	26'2"	26'8"	27'2"
Static tipping load with level arms and forks, straight	kg	9221	8974	8731
	lb	20,329	19,784	19,249
Static tipping load with level arms and forks, full 40° turn	kg	7875	7661	7451
	lb	17,361	16,890	16,427
Operating weight	kg	15 743	15 764	15 786
	lb	34,707	34,754	34,802

		Construction Forks – Fusion	
Fork tine length	mm	1524	1829
	ft/in	5'0"	6'0"
Ground to top of tine clearance	mm	3693	3693
	ft/in	12'1"	12'1"
Reach with lift arms horizontal and forks level	mm	1675	1675
	ft/in	5'6"	5'6"
Overall length	mm	8366	8671
	ft/in	27'5"	28'5"
Static tipping load with level arms and forks, straight	kg	8405	7922
	lb	18,530	17,465
Static tipping load with level arms and forks, full 40° turn	kg	7136	6762
	lb	15,732	14,908
Operating weight	kg	16 266	16 311
	lb	35,860	35,960

*Meets Tier 4 Final/Stage IV/Japan 2014 (Tier 4 Final) emission standards.

NOTE: Dimensions listed are for a machine configured with attachment, counterweights, additional guarding, 80 kg (176 lb) operator, and Michelin 20.5 R25 (L-3) XHA2 tires.

Wheel Loaders Integrated Toolcarriers

- ## Performance Data
- 938M* Standard Lift
 - Material Handling Arm

Handling Arm Position		Material Handling Arm – Fusion		
		Retracted	Mid-position	Extended
Operating load	kg	2638	2241	1948
	lb	5815	4939	4293
Static tipping load, straight	kg	6053	5142	4470
	lb	13,345	11,336	9855
Static tipping load, full 40° turn	kg	5275	4481	3895
	lb	11,629	9879	8587
Operating weight	kg	15 799	15 799	15 799
	lb	34,831	34,831	34,831

*Meets Tier 4 Final/Stage IV/Japan 2014 (Tier 4 Final) emission standards.

NOTE: Dimensions listed are for a machine configured with attachment, counterweights, additional guarding, 80 kg (**176 lb**) operator, and Michelin 20.5 R25 (L-3) XHA2 tires.

Performance Data
 ● 938M* High Lift
 ● Pallet Forks ● Construction Forks

Wheel Loaders
 Integrated Toolcarriers

		Pallet Forks – Fusion		
Fork tine length	mm	1220	1370	1524
	ft/in	4'0"	4'6"	5'0"
Ground to top of tine clearance	mm	4339	4339	4339
	ft/in	14'3"	14'3"	14'3"
Reach with lift arms horizontal and forks level	mm	1714	1714	1714
	ft/in	5'7"	5'7"	5'7"
Overall length	mm	8695	8845	8999
	ft/in	28'6"	29'0"	29'6"
Static tipping load with level arms and forks, straight	kg	6947	6872	6618
	lb	15,315	15,150	14,590
Static tipping load with level arms and forks, full 40° turn	kg	5886	5742	5600
	lb	12,976	12,659	12,346
Operating weight	kg	15 830	15 851	15 873
	lb	34,899	34,945	34,994

		Pallet Forks – ISO		
Fork tine length	mm	1220	1370	1524
	ft/in	4'0"	4'6"	5'0"
Ground to top of tine clearance	mm	4336	4336	4336
	ft/in	14'3"	14'3"	14'3"
Reach with lift arms horizontal and forks level	mm	2241	2241	2241
	ft/in	7'4"	7'4"	7'4"
Overall length	mm	8717	8867	9021
	ft/in	28'7"	29'1"	29'7"
Static tipping load with level arms and forks, straight	kg	6963	6799	6636
	lb	15,351	14,989	14,630
Static tipping load with level arms and forks, full 40° turn	kg	5913	5771	5630
	lb	13,036	12,723	12,412
Operating weight	kg	15 641	15 663	15 684
	lb	34,482	34,531	34,577

		Construction Forks – Fusion	
Fork tine length	mm	1524	1829
	ft/in	5'0"	6'0"
Ground to top of tine clearance	mm	4274	4274
	ft/in	14'0"	14'0"
Reach with lift arms horizontal and forks level	mm	2282	2282
	ft/in	7'6"	7'6"
Overall length	mm	9103	9408
	ft/in	29'10"	30'10"
Static tipping load with level arms and forks, straight	kg	6295	6004
	lb	13,878	13,237
Static tipping load with level arms and forks, full 40° turn	kg	5298	5046
	lb	11,680	11,125
Operating weight	kg	16 164	16 209
	lb	35,635	35,735

*Meets Tier 4 Final/Stage IV/Japan 2014 (Tier 4 Final) emission standards.

NOTE: Dimensions listed are for a machine configured with attachment, counterweights, additional guarding, 80 kg (176 lb) operator, and Michelin 20.5 R25 (L-3) XHA2 tires.

Wheel Loaders Integrated Toolcarriers

- ## Performance Data
- 938M* High Lift
 - Material Handling Arm

Handling Arm Position		Material Handling Arm – Fusion		
		Retracted	Mid-position	Extended
Operating load	kg	2092	1810	1595
	lb	4612	3989	3515
Static tipping load, straight	kg	4831	4179	3682
	lb	10,651	9213	8117
Static tipping load, full 40° turn	kg	4184	3619	3189
	lb	9224	7979	7031
Operating weight	kg	15 697	15 697	15 697
	lb	34,606	34,606	34,606

*Meets Tier 4 Final/Stage IV/Japan 2014 (Tier 4 Final) emission standards.

NOTE: Dimensions listed are for a machine configured with Fusion attachment, counterweights, additional guarding, 80 kg (176 lb) operator, and Michelin 20.5 R25 (L3) XHA2 tires.

Bucket Type		General Purpose			Light Material	
		Pin On			Pin On	
Rated bucket capacity	m ³	1.7	1.9	2.1	3.5	4.2
	yd ³	2.2	2.5	2.7	4.6	5.5
Struck capacity	m ³	1.3	1.7	1.9	3.3	4.0
	yd ³	1.7	2.2	2.5	4.3	5.2
Bucket width	mm	2550	2550	2550	2750	2750
	ft/in	8'4"	8'4"	8'4"	9'0"	9'0"
Nominal material density 100 percent fill factor	kg/m ³	2305	2043	1835	1028	827
	lb/yd ³	3937	3424	3147	1724	1392
Dump clearance at full lift and 45° discharge	mm	2915	2857	2801	2575	2455
	ft/in	9'6"	9'4"	9'2"	8'5"	8'0"
Reach at full lift and 45° discharge	mm	882	950	990	1094	1214
	ft/in	2'10"	3'1"	3'2"	3'7"	3'11"
Reach at 45° discharge and 2130 mm (7'0") clearance	mm	1440	1480	1492	1463	1499
	ft/in	4'8"	4'10"	4'10"	4'9"	4'11"
Reach with lift arms horizontal and bucket level	mm	2142	2231	2303	2556	2726
	ft/in	7'0"	7'3"	7'6"	8'4"	8'11"
Digging depth	mm	100	100	100	100	100
	in	3.9	3.9	3.9	3.9	3.9
Overall length	mm	7284	7374	7446	7699	7869
	ft/in	23'10"	24'2"	24'5"	25'3"	25'9"
Overall height with bucket at full raise	mm	5002	4997	5068	5229	5390
	ft/in	16'4"	16'4"	16'7"	17'1"	17'8"
Loader clearance radius with bucket in carry position	mm	5297	5903	5925	6094	6148
	ft/in	17'4"	19'4"	19'5"	19'11"	20'2"
Tipping load — straight (ISO 14397-1)*	kg	9153	9053	8990	8442	8172
	lb	20,179	19,958	19,818	18,612	18,016
Tipping load — straight (Rigid Tire)**	kg	9535	9430	9364	8794	8513
	lb	21,020	20,789	20,644	19,387	18,767
Tipping load — full turn (ISO 14397-1)*	kg	7858	7765	7708	7194	6945
	lb	17,324	17,118	16,992	15,858	15,310
Tipping load — full turn (Rigid Tire)**	kg	8360	8260	8199	7653	7388
	lb	18,430	18,211	18,076	16,871	16,288
Breakout force	kg	12 273	10 342	9645	7626	6660
	lb	27,056	22,801	21,264	16,812	14,682
Operating weight	kg	11 966	12 019	12 038	12 418	12 555
	lb	26,380	26,498	26,539	27,376	27,679

*Full compliance to ISO 14397-1 (2007) Sections 1 thru 6, which requires 2% verification between calculation and testing.

**Compliance to ISO 14397-1 (2007) Sections 1 thru 5.

NOTE: Dimensions listed are for a 924K configured with general purpose buckets, bolt-on cutting edges, optional counterweights, 80 kg (176 lb) operator, and Michelin 20.5 R25 (L-3) XHA2 tires at a pressure of 4.14 bar (60 psi) in the front tires and 2.76 bar (40 psi) in the rear tires.

Bucket Type		General Purpose			Light Material		ISO 23727	
		Fusion			Fusion			
Rated bucket capacity	m ³	1.9	2.1	2.3	3.5	4.2	2.1	2.3
	yd ³	2.5	2.7	3.0	4.6	5.5	2.7	3.0
Struck capacity	m ³	1.7	1.9	2.1	3.3	4.0	2.0	2.2
	yd ³	2.2	2.5	2.7	4.3	5.2	2.6	2.9
Bucket width	mm	2550	2550	2550	2750	2750	2550	2550
	ft/in	8'4"	8'4"	8'4"	9'0"	9'0"	8'4"	8'4"
Nominal material density 100 percent fill factor	kg/m ³	1948	1744	1576	977	785	1676	1515
	lb/yd ³	3263	2990	2664	1638	1321	2874	2560
Dump clearance at full lift and 45° discharge	mm	2830	2773	2725	2545	2425	2693	2643
	ft/in	9'3"	9'1"	8'11"	8'4"	7'11"	8'10"	8'8"
Reach at full lift and 45° discharge	mm	982	1022	1059	1124	1244	1126	1162
	ft/in	3'2"	3'4"	3'5"	3'8"	4'0"	3'8"	3'9"
Reach at 45° discharge and 2130 mm (7'0") clearance	mm	1499	1509	1520	1473	1506	1568	1575
	ft/in	4'11"	4'11"	4'11"	4'9"	4'11"	5'1"	5'1"
Reach with lift arms horizontal and bucket level	mm	2273	2345	2408	2598	2768	2476	2539
	ft/in	7'5"	7'8"	7'10"	8'6"	9'0"	8'1"	8'3"
Digging depth	mm	100	100	100	100	100	93	93
	in	3.9	3.9	3.9	3.9	3.9	3.7	3.7
Overall length	mm	7416	7488	7551	7741	7911	7613	7676
	ft/in	24'3"	24'6"	24'9"	25'4"	25'11"	24'11"	25'2"
Overall height with bucket at full raise	mm	5022	5093	5151	5254	5417	5182	5240
	ft/in	16'5"	16'8"	16'10"	17'2"	17'9"	17'0"	17'2"
Loader clearance radius with bucket in carry position	mm	5916	5938	5957	6107	6163	5959	5980
	ft/in	19'4"	19'5"	19'6"	20'0"	20'2"	19'6"	19'7"
Tipping load — straight (ISO 14397-1)*	kg	8667	8583	8503	8064	7799	8252	8174
	lb	19,107	18,921	18,745	17,777	17,193	18,192	18,019
Tipping load — straight (Rigid Tire)**	kg	9028	8940	8857	8400	8124	8596	8514
	lb	19,903	19,709	19,526	18,518	17,909	18,950	18,770
Tipping load — full turn (ISO 14397-1)*	kg	7401	7323	7250	6836	6593	7040	6968
	lb	16,317	16,145	15,983	15,071	14,534	15,521	15,362
Tipping load — full turn (Rigid Tire)**	kg	7874	7791	7713	7273	7013	7490	7413
	lb	17,358	17,175	17,003	16,033	15,461	16,512	16,343
Breakout force	kg	9893	9238	8725	7349	6433	8174	7756
	lb	21,811	20,365	19,235	16,200	14,181	18,020	17,098
Operating weight	kg	12 361	12 405	12 443	12 768	12 908	12 352	12 390
	lb	27,250	27,348	27,431	28,148	28,456	27,231	27,315

*Full compliance to ISO 14397-1 (2007) Sections 1 thru 6, which requires 2% verification between calculation and testing.

**Compliance to ISO 14397-1 (2007) Sections 1 thru 5.

NOTE: Dimensions listed are for a 924K configured with general purpose buckets, bolt-on cutting edges, optional counterweights, 80 kg (176 lb) operator, and Michelin 20.5 R25 (L-3) XHA2 tires at a pressure of 4.14 bar (60 psi) in the front tires and 2.76 bar (40 psi) in the rear tires.

● 924K Standard Lift Pin On or Hook On Bucket

Performance Data

Wheel Loaders
Integrated Toolcarriers

	Change in Operating Weight		Change in Tipping Load – Full Turn with 1.9 m ³ (2.5 yd ³) Fusion Bucket	
	kg	lb	kg	lb
Without optional counterweight	- 320	- 705	- 521	- 1148
Without cab (semi-cab option)	- 100	- 220	- 116	- 255
With guard, driveshaft	+ 44	+ 97	+ 12	+ 26
With ride control	+ 49	+ 108	+ 27	+ 59
With roading fenders	+ 18	+ 39	+ 25	+ 55
With guards, front lights	+ 11	+ 24	+ 2	+ 4
With guard, hitch	+ 54	+ 119	+ 37	+ 81
With guard, front window	+ 34	+ 74	+ 19	+ 41
With guards, steering cylinders	+ 14	+ 30	+ 10	+ 22
With guard, power train lower	+ 77	+ 169	+ 72	+ 158
With secondary steering	+ 69	+ 152	+ 76	+ 167
With guard, crankcase	+ 19	+ 41	+ 25	+ 55
With guards, power train side	+ 11	+ 24	+ 9	+ 19
With tool box	+ 44	+ 97	+ 26	+ 57
With cold start package	+ 54	+ 119	+ 77	+ 169
With counterweight, logger	+ 299	+ 658	+ 417	+ 919
20.5-25 12PR	- 282	- 621	- 164	- 361
17.5 R25 (L-2)	- 40	- 88	- 187	- 412

Wheel Loaders Integrated Toolcarriers

Performance Data

- 924K Standard Lift Fusion
- Pallet Forks ● Construction Forks
- Material Handling Arm

		Pallet Forks	Construction Forks
Fork tine length	mm	1220	1524
	ft/in	4'0"	5'0"
Load center	mm	610	762
	ft/in	2'0"	2'6"
Overall length	mm	7840	8263
	ft/in	25'8"	27'1"
Ground reach	mm	891	1009
	ft/in	2'11"	3'3"
Digging depth	mm	47	120
	in	1.9	4.7
Level arm reach	mm	1522	1580
	ft/in	4'11"	5'2"
Full lift reach	mm	724	782
	ft/in	2'4"	2'6"
Level arm clearance	mm	1761	1698
	ft/in	5'9"	5'6"
Full lift clearance	mm	3639	3575
	ft/in	11'11"	11'8"
Overall height	mm	4621	4880
	ft/in	15'1"	16'0"
Tipping load — straight (ISO 14397-1)*	kg	6615	5911
	lb	14,578	13,028
Tipping load — full turn (ISO 14397-1)*	kg	5670	5036
	lb	12,495	11,099
Operating weight	kg	12 070	12 404
	lb	26,601	27,338
Rated load (% of full turn tip): 50% of tip (SAE J1197)**	kg	2835	2518
	lb	6247	5549
Rated load (% of full turn tip): 60% of tip — rough terrain (EN474-3)**	kg	3402	3022
	lb	7497	6659
Rated load (% of full turn tip): 80% of tip — firm and level (EN474-3)**	kg	4536	4029
	lb	9996	8879

*Full compliance to ISO 14397-1 (2007) Sections 1 thru 6, which requires 2% verification between calculation and testing.

**Full compliance to EN474-3 and SAE J1197.

NOTE: Dimensions listed are for a machine configured with Fusion forks, optional counterweights, 80 kg (176 lb) operator, and Michelin 20.5 R25 (L-3) XHA2 tires.

Handling Arm Position		Material Handling Arm		
		Retracted	Mid-position	Extended
Rated load (50% of full turn tip* SAE J1197)	kg	1853	1569	1361
	lb	4085	3459	2999
Operating weight	kg	11 926	11 926	11 926
	lb	26,292	26,292	26,292

*Full compliance to EN474-3 and SAE J1197.

Bucket Type		General Purpose			Light Material		High Lift Delta
		Pin On			Pin On		
Rated bucket capacity	m ³	2.1	2.3	2.5	4.2	5.0	—
	yd ³	2.7	3.0	3.3	5.5	6.5	—
Struck capacity	m ³	1.9	2.1	2.3	4.0	4.8	—
	yd ³	2.5	2.7	3.0	5.2	6.3	—
Bucket width	mm	2550	2550	2550	2750	2750	—
	ft/in	8'4"	8'4"	8'4"	9'0"	9'0"	—
Nominal material density 100 percent fill factor	kg/m ³	2018	1821	1649	915	765	—
	lb/yd ³	3461	3077	2754	1541	1298	—
Dump clearance at full lift and 45° discharge	mm	2855	2807	2761	2509	2509	+593
	ft/in	9'4"	9'2"	9'0"	8'2"	8'2"	+1'11"
Reach at full lift and 45° discharge	mm	1033	1070	1109	1257	1257	+320
	ft/in	3'4"	3'6"	3'7"	4'1"	4'1"	+1'0"
Reach at 45° discharge and 2130 mm (7'0") clearance	mm	1560	1573	1587	1579	1579	+717
	ft/in	5'1"	5'1"	5'2"	5'2"	5'2"	+2'4"
Reach with lift arms horizontal and bucket level	mm	2350	2413	2475	2773	2773	+653
	ft/in	7'8"	7'11"	8'1"	9'1"	9'1"	+2'1"
Digging depth	mm	100	100	100	100	100	+35
	in	3.9	3.9	3.9	3.9	3.9	+1.4
Overall length	mm	7488	7651	7613	7911	7911	+794
	ft/in	24'6"	24'9"	24'11"	25'11"	25'11"	+2'7"
Overall height with bucket at full raise	mm	5122	5180	5239	5445	5725	+593
	ft/in	16'9"	16'11"	17'2"	17'10"	18'9"	+1'11"
Loader clearance radius with bucket in carry position	mm	5933	5951	5970	6152	6152	+384
	ft/in	19'5"	19'6"	19'7"	20'2"	20'2"	+1'3"
Tipping load — straight (ISO 14397-1)*	kg	9908	9798	9661	9059	9028	-2723
	lb	21,843	21,601	21,299	19,971	19,902	-6001
Tipping load — straight (Rigid Tire)**	kg	10 321	10 206	10 064	9436	9404	-2836
	lb	22,753	22,501	22,187	20,803	20,731	-6251
Tipping load — full turn (ISO 14397-1)*	kg	8477	8375	8246	7688	7655	-2386
	lb	18,688	18,463	18,179	16,948	16,875	-5259
Tipping load — full turn (Rigid Tire)**	kg	9018	8909	8772	8178	8143	-2539
	lb	19,881	19,641	19,339	18,029	17,952	-5595
Breakout force	kg	12 891	12 158	11 488	9020	8969	-299
	lb	28,419	26,803	25,326	19,885	19,772	-658
Operating weight	kg	13 135	13 198	13 297	13 651	13 721	+247
	lb	28,956	29,096	29,314	30,096	30,250	+544

*Full compliance to ISO 14397-1 (2007) Sections 1 thru 6, which requires 2% verification between calculation and testing.
 **Compliance to ISO 14397-1 (2007) Sections 1 thru 5.

NOTE: Dimensions listed are for a 930K configured with general purpose buckets, bolt-on cutting edges, optional counterweights, 80 kg (176 lb) operator, and Michelin 20.5 R25 (L-3) XHA2 tires at a pressure of 4.14 bar (60 psi) in the front tires and 2.76 bar (40 psi) in the rear tires.

Bucket Type		General Purpose					Light Material		High Lift Delta
		Fusion		ISO 23727			Fusion		
Rated bucket capacity	m ³	2.1	2.3	2.5	2.3	2.5	4.2	5.0	—
	yd ³	2.7	3.0	3.3	3.0	3.3	5.5	6.5	—
Struck capacity	m ³	1.9	2.1	2.3	2.2	2.4	4.0	4.8	—
	yd ³	2.5	2.7	3.0	2.9	3.1	5.2	6.3	—
Bucket width	mm	2550	2550	2550	2550	2750	2750	2750	—
	ft/in	8'4"	8'4"	8'4"	8'4"	9'0"	9'0"	9'0"	—
Nominal material density 100 percent fill factor	kg/m ³	1925	1741	1579	1674	1521	872	730	—
	lb/yd ³	3300	2942	2637	2830	2541	1468	1237	—
Dump clearance at full lift and 45° discharge	mm	2828	2779	2733	2698	2698	2479	2479	+593
	ft/in	9'3"	9'1"	8'11"	8'10"	8'10"	8'1"	8'1"	+1'11"
Reach at full lift and 45° discharge	mm	1064	1102	1140	1205	1205	1286	1286	+320
	ft/in	3'5"	3'7"	3'8"	3'11"	3'11"	4'2"	4'2"	+1'0"
Reach at 45° discharge and 2130 mm (7'0") clearance	mm	1578	1590	1603	1648	1648	1588	1588	+717
	ft/in	5'2"	5'2"	5'3"	5'4"	5'4"	5'2"	5'2"	+2'4"
Reach with lift arms horizontal and bucket level	mm	2392	2455	2517	2586	2586	2815	2815	+653
	ft/in	7'10"	8'0"	8'3"	8'5"	8'5"	9'2"	9'2"	+2'1"
Digging depth	mm	100	100	100	93	93	100	100	+35
	in	3.9	3.9	3.9	3.7	3.7	3.9	3.9	+1.4
Overall length	mm	7530	7593	7655	7718	7718	7953	7953	+794
	ft/in	24'8"	24'10"	25'1"	25'3"	25'3"	26'1"	26'1"	+2'7"
Overall height with bucket at full raise	mm	5147	5205	5264	5294	5294	5471	5752	+593
	ft/in	16'10"	17'0"	17'3"	17'4"	17'4"	17'11"	18'10"	+1'11"
Loader clearance radius with bucket in carry position	mm	5945	5964	5983	5984	6075	6166	6166	+384
	ft/in	19'6"	19'6"	19'7"	19'7"	19'11"	20'2"	20'2"	+1'3"
Tipping load — straight (ISO 14397-1)*	kg	9490	9406	9288	9049	8952	8675	8646	-2723
	lb	20,922	20,737	20,476	19,949	19,736	19,124	19,060	-6001
Tipping load — straight (RigidTire)**	kg	9886	9798	9675	9426	9325	9036	9006	-2836
	lb	21,794	21,601	21,329	20,780	20,558	19,921	19,854	-6251
Tipping load — full turn (ISO 14397-1)*	kg	8083	8007	7896	7702	7607	7326	7295	-2386
	lb	17,820	17,651	17,407	16,979	16,771	16,151	16,083	-5259
Tipping load — full turn (RigidTire)**	kg	8599	8518	8400	8193	8093	7794	7761	-2539
	lb	18,958	18,778	18,518	18,063	17,841	17,182	17,110	-5595
Breakout force	kg	12 366	11 693	11 076	10 432	10 375	8730	8682	-299
	lb	27,262	25,779	24,417	22,998	22,873	19,246	19,139	-658
Operating weight	kg	13 501	13 539	13 621	13 487	13 590	14 004	14 069	+247
	lb	29,765	29,848	30,030	29,732	29,959	30,873	31,017	+544

*Full compliance to ISO 14397-1 (2007) Sections 1 thru 6, which requires 2% verification between calculation and testing.

**Compliance to ISO 14397-1 (2007) Sections 1 thru 5.

NOTE: Dimensions listed are for a 930K configured with general purpose buckets, bolt-on cutting edges, optional counterweights, 80 kg (176 lb) operator, and Michelin 20.5 R25 (L-3) XHA2 tires at a pressure of 4.14 bar (60 psi) in the front tires and 2.76 bar (40 psi) in the rear tires.

● 930K Standard Lift Pin On or Hook On Bucket

Performance Data

Wheel Loaders
Integrated Toolcarriers

	Change in Operating Weight		Change in Tipping Load – Full Turn with 2.1 m ³ (2.75 yd ³) Fusion Bucket	
	kg	lb	kg	lb
Without optional counterweight	- 320	- 705	- 509	- 1121
Without cab (semi-cab option)	- 100	- 220	- 112	- 246
With guard, driveshaft	+ 44	+ 97	+ 12	+ 26
With ride control	+ 49	+ 108	+ 27	+ 59
With roading fenders	+ 18	+ 39	+ 24	+ 52
With guards, front lights	+ 11	+ 24	+ 2	+ 4
With guard, hitch	+ 54	+ 119	+ 36	+ 79
With guard, front window	+ 34	+ 74	+ 19	+ 41
With guards, steering cylinders	+ 14	+ 30	+ 10	+ 22
With guard, power train lower	+ 77	+ 169	+ 70	+ 154
With secondary steering	+ 69	+ 152	+ 74	+ 163
With guard, crankcase	+ 19	+ 41	+ 25	+ 55
With guards, power train side	+ 11	+ 24	+ 9	+ 19
With tool box	+ 44	+ 97	+ 25	+ 55
With guard, rear waste gate	+ 263	+ 580	+ 466	+ 1027
With cold start package	+ 54	+ 119	+ 75	+ 165
With counterweight, logger	+ 299	+ 658	+ 415	+ 914
20.5-25 16PR	- 254	- 559	- 144	- 316
20.5R25 (L-5)	+ 678	+ 1494	+ 384	+ 846

Wheel Loaders Integrated Toolcarriers

Performance Data

- 930K Standard Lift Fusion
- Pallet Forks ● Construction Forks
- Material Handling Arm

		Pallet Forks	Construction Forks
Fork tine length	mm	1220	1524
	ft/in	4'0"	5'0"
Load center	mm	610	762
	ft/in	2'0"	2'6"
Overall length	mm	7882	8305
	ft/in	25'10"	27'2"
Ground reach	mm	926	1045
	ft/in	3'0"	3'5"
Digging depth	mm	47	120
	in	1.9	4.7
Level arm reach	mm	1569	1627
	ft/in	5'1"	5'4"
Full lift reach	mm	767	825
	ft/in	2'6"	2'8"
Level arm clearance	mm	1792	1729
	ft/in	5'10"	5'8"
Full lift clearance	mm	3693	3630
	ft/in	12'1"	11'10"
Overall height	mm	4676	4935
	ft/in	15'4"	16'2"
Tipping load — straight (ISO 14397-1)*	kg	7351	6604
	lb	16,201	14,555
Tipping load — full turn (ISO 14397-1)*	kg	6287	5617
	lb	13,856	12,379
Operating weight	kg	13 166	13 501
	lb	29,017	29,756
Rated load (% of full turn tip): 50% of tip (SAE J1197)**	kg	3144	2808
	lb	6929	6188
Rated load (% of full turn tip): 60% of tip — rough terrain (EN474-3)**	kg	3772	3370
	lb	8313	7427
Rated load (% of full turn tip): 80% of tip — firm and level (EN474-3)**	kg	5030	4494
	lb	11,086	9904

*Full compliance to ISO 14397-1 (2007) Sections 1 thru 6, which requires 2% verification between calculation and testing.

**Full compliance to EN474-3 and SAE J1197.

NOTE: Dimensions listed are for a machine configured with Fusion forks, optional counterweights, 80 kg (176 lb) operator, and Michelin 20.5 R25 (L-3) XHA2 tires.

Handling Arm Position		Material Handling Arm		
		Retracted	Mid-position	Extended
Rated load (50% of full turn tip* SAE J1197)	kg	2135	1811	1572
	lb	4706	3992	3466
Operating weight	kg	13 361	13 361	13 361
	lb	29,456	29,456	29,456

*Full compliance to EN474-3 and SAE J1197.

Bucket Type		General Purpose			Light Material		High Lift Delta
		Pin On			Pin On		
Rated bucket capacity	m ³	2.5	2.7	2.9	4.2	5.0	-
	yd ³	3.3	3.5	3.8	5.5	6.5	-
Struck capacity	m ³	2.3	2.5	2.7	4.0	4.8	-
	yd ³	3.0	3.3	3.5	5.2	6.3	-
Bucket width	mm	2750	2750	2750	2750	2750	-
	ft/in	9'0"	9'0"	9'0"	9'0"	9'0"	-
Nominal material density 100 percent fill factor	kg/m ³	1940	1780	1644	1080	905	-
	lb/yd ³	3239	3027	2766	1818	1535	-
Dump clearance at full lift and 45° discharge	mm	2869	2822	2786	2571	2571	+581
	ft/in	9'4"	9'3"	9'1"	8'5"	8'5"	+1'10"
Reach at full lift and 45° discharge	mm	1108	1146	1178	1294	1294	+267
	ft/in	3'7"	3'9"	3'10"	4'2"	4'2"	+11"
Reach at 45° discharge and 2130 mm (7'0") clearance	mm	1637	1652	1664	1654	1654	+666
	ft/in	5'4"	5'5"	5'5"	5'5"	5'5"	+2'2"
Reach with lift arms horizontal and bucket level	mm	2452	2514	2563	2812	2812	+607
	ft/in	8'0"	8'2"	8'4"	9'2"	9'2"	+1'11"
Digging depth	mm	100	100	100	100	100	+35
	in	3.9	3.9	3.9	3.9	3.9	+1.4
Overall length	mm	7604	7666	7715	7964	7964	+740
	ft/in	24'11"	25'1"	25'3"	26'1"	26'1"	+2'5"
Overall height with bucket at full raise	mm	5242	5301	5348	5507	5786	+581
	ft/in	17'2"	17'4"	17'6"	18'0"	18'11"	+1'10"
Loader clearance radius with bucket in carry position	mm	6117	6136	6150	6227	6227	+357
	ft/in	20'0"	20'1"	20'2"	20'5"	20'5"	+1'2"
Tipping load — straight (ISO 14397-1)*	kg	11 735	11 638	11 557	11 049	11 047	-2934
	lb	25,871	25,658	25,480	24,358	24,355	-6466
Tipping load — straight (Rigid Tire)**	kg	12 353	12 251	12 166	11 630	11 629	-3056
	lb	27,233	27,009	26,821	25,640	25,636	-6735
Tipping load — full turn (ISO 14397-1)*	kg	10 099	10 010	9935	9463	9458	-2562
	lb	22,265	22,068	21,903	20,863	20,852	-5646
Tipping load — full turn (Rigid Tire)**	kg	10 744	10 649	10 569	10 067	10 062	-2726
	lb	23,686	23,476	23,301	22,194	22,183	-6007
Breakout force	kg	13 813	13 082	12 552	10 331	10 281	-502
	lb	30,451	28,841	27,673	22,775	22,665	-1106
Operating weight	kg	15 430	15 474	15 511	15 776	15 823	+249
	lb	34,017	34,114	34,196	34,780	34,884	+549

*Full compliance to ISO 14397-1 (2007) Sections 1 thru 6, which requires 2% verification between calculation and testing.

**Compliance to ISO 14397-1 (2007) Sections 1 thru 5.

NOTE: Dimensions listed are for a 938K configured with general purpose buckets, bolt-on cutting edges, optional counterweights, 80 kg (176 lb) operator, and Michelin 20.5 R25 (L-3) XHA2 tires at a pressure of 4.48 bar (65 psi) in the front tires and 2.76 bar (40 psi) in the rear tires.

Bucket Type		General Purpose					Light Material		High Lift Delta
		Fusion		ISO 23727			Fusion		
Rated bucket capacity	m ³	2.5	2.7	2.9	2.7	2.9	4.2	5.0	–
	yd ³	3.3	3.5	3.8	3.5	3.8	5.5	6.5	–
Struck capacity	m ³	2.3	2.5	2.7	2.6	2.7	4.0	4.8	–
	yd ³	3.0	3.3	3.5	3.4	3.5	5.2	6.3	–
Bucket width	mm	2750	2750	2750	2750	2750	2750	2750	–
	ft/in	9'0"	9'0"	9'0"	9'0"	9'0"	9'0"	9'0"	–
Nominal material density 100 percent fill factor	kg/m ³	1848	1695	1566	1644	1519	1029	861	–
	lb/yd ³	3086	2882	2634	2796	2556	1732	1461	–
Dump clearance at full lift and 45° discharge	mm	2834	2787	2751	2712	2675	2534	2534	+581
	ft/in	9'3"	9'1"	9'0"	8'10"	8'9"	8'3"	8'3"	+1'10"
Reach at full lift and 45° discharge	mm	1146	1185	1216	1280	1311	1331	1331	+267
	ft/in	3'9"	3'10"	3'11"	4'2"	4'3"	4'4"	4'4"	+11"
Reach at 45° discharge and 2130 mm (7'0") clearance	mm	1658	1672	1684	1726	1735	1666	1666	+666
	ft/in	5'5"	5'5"	5'6"	5'7"	5'8"	5'5"	5'5"	+2'2"
Reach with lift arms horizontal and bucket level	mm	2504	2566	2615	2687	2736	2864	2864	+607
	ft/in	8'2"	8'5"	8'6"	8'9"	8'11"	9'4"	9'4"	+1'11"
Digging depth	mm	101	101	101	93	93	101	101	+35
	in	4.0	4.0	4.0	3.7	3.7	4.0	4	+1.4
Overall length	mm	7656	7718	7767	7833	7882	8016	8016	+740
	ft/in	25'1"	25'3"	25'5"	25'8"	25'10"	26'3"	26'3"	+2'5"
Overall height with bucket at full raise	mm	5273	5332	5379	5415	5462	5539	5820	+581
	ft/in	17'3"	17'5"	17'7"	17'9"	17'11"	18'2"	19'1"	+1'10"
Loader clearance radius with bucket in carry position	mm	6133	6152	6166	6169	6185	6244	6244	+357
	ft/in	20'1"	20'2"	20'2"	20'2"	20'3"	20'5"	20'5"	+1'2"
Tipping load — straight (ISO 14397-1)*	kg	11 223	11 128	11 050	10 676	10 605	10 574	10 543	–2934
	lb	24,743	24,532	24,360	23,538	23,379	23,313	23,244	–6466
Tipping load — straight (RigidTire)**	kg	11 814	11 713	11 631	11 238	11 163	11 131	11 098	–3056
	lb	26,045	25,824	25,642	24,776	24,610	24,540	24,467	–6735
Tipping load — full turn (ISO 14397-1)*	kg	9616	9528	9456	9143	9077	9016	8982	–2562
	lb	21,200	21,005	20,846	20,158	20,011	19,877	19,803	–5646
Tipping load — full turn (RigidTire)**	kg	10 230	10 136	10 059	9727	9656	9592	9556	–2726
	lb	22,553	22,346	22,177	21,445	21,288	21,146	21,067	–6007
Breakout force	kg	13 170	12 498	12 009	11 299	10 887	9936	9888	–502
	lb	29,035	27,554	26,475	24,909	24,000	21,905	21,798	–1106
Operating weight	kg	15 856	15 900	15 936	15 796	15 830	16 186	16 264	+249
	lb	34,956	35,053	35,133	34,824	34,899	35,684	35,856	+549

*Full compliance to ISO 14397-1 (2007) Sections 1 thru 6, which requires 2% verification between calculation and testing.

**Compliance to ISO 14397-1 (2007) Sections 1 thru 5.

NOTE: Dimensions listed are for a 938K configured with general purpose buckets, bolt-on cutting edges, optional counterweights, 80 kg (176 lb) operator, and Michelin 20.5 R25 (L-3) XHA2 tires at a pressure of 4.48 bar (65 psi) in the front tires and 2.76 bar (40 psi) in the rear tires.

● 938K Standard Lift Pin On or Hook On Bucket

Performance Data

Wheel Loaders
Integrated Toolcarriers

	Change in Operating Weight		Change in Tipping Load – Full Turn with 2.5 m ³ (3.25 yd ³) Fusion Bucket	
	kg	lb	kg	lb
Without optional counterweight	- 320	- 705	- 502	- 1106
Without cab (semi-cab option)	- 100	- 220	- 113	- 249
With guard, driveshaft	+ 45	+ 99	+ 12	+ 26
With ride control	+ 49	+ 108	+ 27	+ 59
With roading fenders	+ 18	+ 39	+ 24	+ 52
With guards, front lights	+ 11	+ 24	+ 2	+ 4
With guard, hitch	+ 54	+ 119	+ 36	+ 79
With guard, front window	+ 34	+ 74	+ 19	+ 41
With guards, steering cylinders	+ 14	+ 30	+ 10	+ 22
With guard, power train lower	+ 70	+ 154	+ 63	+ 138
With secondary steering	+ 69	+ 152	+ 74	+ 163
With guard, crankcase	+ 11	+ 24	+ 14	+ 30
With guards, power train side	+ 11	+ 24	+ 9	+ 19
With tool box	+ 44	+ 97	+ 25	+ 55
With guard, rear waste gate	+ 276	+ 608	+ 488	+ 1075
With cold start package	+ 54	+ 119	+ 75	+ 165
With counterweight, logger	+ 299	+ 658	+ 402	+ 886
20.5R25 (L5)	+ 678	+ 1494	+ 381	+ 839
650/65 R25	+ 506	+ 115	+ 285	+ 628

Wheel Loaders Integrated Toolcarriers

Performance Data

- 938K Standard Lift Fusion
- Pallet Forks ● Construction Forks

		Pallet Forks	Construction Forks
Fork tine length	mm	1220	1524
	ft/in	4'0"	5'0"
Load center	mm	610	762
	ft/in	2'0"	2'6"
Overall length	mm	7942	8366
	ft/in	26'0"	27'5"
Ground reach	mm	961	1081
	ft/in	3'1"	3'6"
Digging depth	mm	44	119
	in	1.7	4.7
Level arm reach	mm	1617	1675
	ft/in	5'3"	5'5"
Full lift reach	mm	814	872
	ft/in	2'8"	2'10"
Level arm clearance	mm	1830	1766
	ft/in	6'0"	5'9"
Full lift clearance	mm	3758	3693
	ft/in	12'3"	12'1"
Overall height	mm	4740	4998
	ft/in	15'6"	16'4"
Tipping load — straight (ISO 14397-1)*	kg	8818	7982
	lb	19,440	17,597
Tipping load — full turn (ISO 14397-1)*	kg	7597	6844
	lb	16,748	15,088
Operating weight	kg	15 361	15 695
	lb	33,865	34,602
Rated load (% of full turn tip): 50% of tip (SAE J1197)**	kg	3799	3422
	lb	8374	7544
Rated load (% of full turn tip): 60% of tip — rough terrain (EN474-3)**	kg	4558	4106
	lb	10,049	9053
Rated load (% of full turn tip): 80% of tip — firm and level (EN474-3)**	kg	6078	5475
	lb	13,399	12,071

*Full compliance to ISO 14397-1 (2007) Sections 1 thru 6, which requires 2% verification between calculation and testing.

**Full compliance to EN474-3 and SAE J1197.

NOTE: Dimensions listed are for a machine configured with Fusion forks, optional counterweights, 80 kg (176 lb) operator, and Michelin 20.5 R25 (L-3) XHA2 tires.

Performance Data
 ● 938K Standard Lift Fusion
 ● Material Handling Arm

Wheel Loaders
 Integrated Toolcarriers

Handling Arm Position		Material Handling Arm – Fusion		
		Retracted	Mid-position	Extended
Operating load	kg	2534	2153	1871
	lb	5586	4746	4125
Static tipping load, straight	kg	5817	4942	4296
	lb	12,824	10,895	9471
Static tipping load, full 40° turn	kg	5067	4305	3742
	lb	11,172	9491	8250
Operating weight	kg	15 228	15 228	15 228
	lb	33,571	33,571	33,571

*Full compliance to EN474-3 and SAE J1197.

Bucket Type	General Purpose — Pin On							High Lift Delta
Bucket Part Number	354-4849	354-4849	354-4849	354-4851	354-4851	354-4851		
Edge Type	Bolt-on Cutting Edges	Teeth & Segments	Tips	Bolt-on Cutting Edges	Teeth & Segments	Tips		
Capacity — rated	m ³ yd ³	2.70 3.53	2.70 3.53	2.50 3.27	2.90 3.79	2.90 3.79	2.70 3.53	— —
Capacity — 110%	m ³ yd ³	2.97 3.88	2.97 3.88	2.75 3.60	3.19 4.17	3.19 4.17	2.97 3.88	— —
Width	mm ft/in	2927 9'7"	2994 9'9"	2994 9'9"	2927 9'7"	2994 9'9"	2994 9'9"	— —
Dump clearance at maximum lift and 45° discharge	mm ft/in	2975 9'9"	2859 9'4"	2859 9'4"	2919 9'6"	2802 9'2"	2802 9'2"	505 1'7"
Reach at maximum lift and 45° discharge	mm ft/in	1356 4'5"	1469 4'9"	1469 4'9"	1395 4'6"	1506 4'11"	1506 4'11"	36 1"
Reach at level lift arm and bucket level	mm ft/in	2562 8'4"	2723 8'11"	2723 8'11"	2631 8'7"	2792 9'1"	2792 9'1"	375 1'2"
Digging depth	mm in	90 3.5	90 3.5	60 2.3	90 3.5	90 3.5	60 2.3	4 0
Overall length	mm ft/in	8073 26'6"	8246 27'1"	8246 27'1"	8142 26'9"	8315 27'4"	8315 27'4"	583 1'10"
Overall height with bucket at maximum lift	mm ft/in	5392 17'9"	5392 17'9"	5392 17'9"	5464 18'0"	5464 18'0"	5464 18'0"	505 1'7"
Loader clearance circle with bucket at carry position	mm ft/in	13 689 44'11"	13 856 45'6"	13 856 45'6"	13 729 45'1"	13 897 45'8"	13 897 45'8"	393 1'3"
Static tipping load, straight (With Tire Deflection)*	kg lb	13 003 28,660	12 865 28,355	13 164 29,014	12 862 28,349	12 723 28,041	13 014 28,684	-1277 -2815
Static tipping load, straight (No Tire Deflection)*	kg lb	13 737 30,276	13 597 29,969	13 905 30,646	13 599 29,973	13 458 29,662	13 757 30,322	-1436 -3166
Static tipping load, articulated (With Tire Deflection)*	kg lb	11 227 24,745	11 089 24,441	11 369 25,057	11 091 24,446	10 952 24,138	11 225 24,740	-1184 -2610
Static tipping load, articulated (No Tire Deflection)*	kg lb	11 975 26,393	11 835 26,085	12 123 26,719	11 842 26,101	11 701 25,790	11 982 26,408	-1334 -2941
Breakout force	kN lbf	202 45,434	200 45,144	221 49,798	190 42,709	188 42,422	207 46,570	-9 -20
Operating weight*	kg lb	19 092 42,079	19 200 42,317	19 043 41,971	19 177 42,265	19 285 42,503	19 128 42,157	602 1327

*Static tipping loads and operating weights shown are based on a machine configuration with Michelin 23.5R25 XHA2 L3 radial tires, full fluids, operator, cold start, roading fenders, Product Link, Manual Diff Lock/Open axles (front/rear), power train guard, secondary steering and sound suppression. (With Tire Deflection) Full compliance to ISO 14397-1 (2007) Sections 1 thru 6, which requires 2% verification between calculations and testing. (No Tire Deflection) Compliance to ISO 14397-1 (2007) Sections 1 thru 5.

NOTE: Machine and bucket availability varies by region. Consult your local dealer for availability.

Bucket Type	General Purpose — Pin On							High Lift Delta
	Bucket Part Number	352-5537	352-5537	352-5537	352-5538	352-5538	352-5538	
Edge Type		Bolt-on Cutting Edges	Teeth & Segments	Tips	Bolt-on Cutting Edges	Teeth & Segments	Tips	
Capacity — rated	m ³	3.10	3.10	2.90	3.30	3.30	3.10	—
	yd ³	4.05	4.05	3.79	4.32	4.32	4.05	—
Capacity — 110%	m ³	3.41	3.41	3.19	3.63	3.63	3.41	—
	yd ³	4.46	4.46	4.17	4.75	4.75	4.46	—
Width	mm	2927	2994	2994	2927	2994	2994	—
	ft/in	9'7"	9'9"	9'9"	9'7"	9'9"	9'9"	—
Dump clearance at maximum lift and 45° discharge	mm	2876	2758	2758	2838	2719	2719	505
	ft/in	9'5"	9'0"	9'0"	9'3"	8'11"	8'11"	1'7"
Reach at maximum lift and 45° discharge	mm	1429	1540	1540	1458	1568	1568	36
	ft/in	4'8"	5'0"	5'0"	4'9"	5'1"	5'1"	1"
Reach at level lift arm and bucket level	mm	2688	2849	2849	2737	2898	2898	375
	ft/in	8'9"	9'4"	9'4"	8'11"	9'6"	9'6"	1'2"
Digging depth	mm	90	90	60	90	90	60	4
	in	3.5	3.5	2.3	3.5	3.5	2.3	0
Overall length	mm	8199	8372	8372	8248	8421	8421	583
	ft/in	26'11"	27'6"	27'6"	27'1"	27'8"	27'8"	1'10"
Overall height with bucket at maximum lift	mm	5525	5525	5525	5571	5571	5571	505
	ft/in	18'2"	18'2"	18'2"	18'4"	18'4"	18'4"	1'7"
Loader clearance circle with bucket at carry position	mm	13 762	13 931	13 931	13 791	13 961	13 961	393
	ft/in	45'2"	45'9"	45'9"	45'3"	45'10"	45'10"	1'3"
Static tipping load, straight (With Tire Deflection)*	kg	12 769	12 629	12 912	12 649	12 507	12 789	-1277
	lb	28,144	27,834	28,458	27,878	27,566	28,187	-2815
Static tipping load, straight (No Tire Deflection)*	kg	13 510	13 368	13 658	13 391	13 248	13 537	-1436
	lb	29,776	29,463	30,103	29,514	29,199	29,835	-3166
Static tipping load, articulated (With Tire Deflection)*	kg	11 004	10 864	11 129	10 889	10 747	11 011	-1184
	lb	24,254	23,944	24,529	23,999	23,687	24,268	-2610
Static tipping load, articulated (No Tire Deflection)*	kg	11 759	11 617	11 889	11 645	11 502	11 772	-1334
	lb	25,917	25,604	26,203	25,666	25,351	25,947	-2941
Breakout force	kN	181	179	196	173	172	188	-9
	lbf	40,706	40,421	44,216	39,080	38,797	42,322	-20
Operating weight*	kg	19 214	19 322	19 165	19 283	19 391	19 234	602
	lb	42,346	42,584	42,238	42,499	42,737	42,391	1327

*Static tipping loads and operating weights shown are based on a machine configuration with Michelin 23.5R25 XHA2 L3 radial tires, full fluids, operator, cold start, roading fenders, Product Link, Manual Diff Lock/Open axles (front/rear), power train guard, secondary steering and sound suppression. (With Tire Deflection) Full compliance to ISO 14397-1 (2007) Sections 1 thru 6, which requires 2% verification between calculations and testing. (No Tire Deflection) Compliance to ISO 14397-1 (2007) Sections 1 thru 5.

NOTE: Machine and bucket availability varies by region. Consult your local dealer for availability.

Bucket Type Bucket Part Number	General Purpose — Pin On						High Lift Delta	
	354-4853	354-4853	354-4853	354-4855	354-4855	354-4855		
Edge Type	Bolt-on Cutting Edges	Teeth & Segments	Tips	Bolt-on Cutting Edges	Teeth & Segments	Tips		
Capacity — rated	m ³ yd ³	3.40 4.45	3.40 4.45	3.20 4.19	3.60 4.71	3.60 4.71	3.40 4.45	— —
Capacity — 110%	m ³ yd ³	3.74 4.89	3.74 4.89	3.52 4.60	3.96 5.18	3.96 5.18	3.74 4.89	— —
Width	mm ft/in	2927 9'7"	2994 9'9"	2994 9'9"	2927 9'7"	2994 9'9"	2994 9'9"	— —
Dump clearance at maximum lift and 45° discharge	mm ft/in	2819 9'3"	2700 8'10"	2700 8'10"	2793 9'1"	2673 8'9"	2673 8'9"	505 1'7"
Reach at maximum lift and 45° discharge	mm ft/in	1473 4'10"	1582 5'2"	1582 5'2"	1495 4'10"	1604 5'3"	1604 5'3"	36 1"
Reach at level lift arm and bucket level	mm ft/in	2761 9'0"	2922 9'7"	2922 9'7"	2796 9'2"	2957 9'8"	2957 9'8"	375 1'2"
Digging depth	mm in	90 3.5	90 3.5	60 2.3	90 3.5	90 3.5	60 2.3	4 0
Overall length	mm ft/in	8272 27'2"	8445 27'9"	8445 27'9"	8307 27'4"	8480 27'10"	8480 27'10"	583 1'10"
Overall height with bucket at maximum lift	mm ft/in	5597 18'5"	5597 18'5"	5597 18'5"	5630 18'6"	5630 18'6"	5630 18'6"	505 1'7"
Loader clearance circle with bucket at carry position	mm ft/in	13 805 45'4"	13 975 45'11"	13 975 45'11"	13 826 45'5"	13 997 46'0"	13 997 46'0"	393 1'3"
Static tipping load, straight (With Tire Deflection)*	kg lb	12 605 27,783	12 463 27,469	12 742 28,083	12 535 27,627	12 392 27,313	12 667 27,918	-1277 -2815
Static tipping load, straight (No Tire Deflection)*	kg lb	13 349 29,421	13 205 29,105	13 491 29,734	13 280 29,270	13 135 28,951	13 417 29,572	-1436 -3166
Static tipping load, articulated (With Tire Deflection)*	kg lb	10 847 23,908	10 705 23,594	10 966 24,169	10 780 23,760	10 637 23,445	10 895 24,013	-1184 -2610
Static tipping load, articulated (No Tire Deflection)*	kg lb	11 605 25,577	11 461 25,260	11 728 25,849	11 539 25,433	11 395 25,115	11 658 25,696	-1334 -2941
Breakout force	kN lbf	170 38,333	169 38,050	184 41,455	165 37,288	164 37,006	179 40,247	-9 -20
Operating weight*	kg lb	19 307 42,552	19 415 42,790	19 258 42,444	19 343 42,632	19 451 42,870	19 294 42,524	602 1327

*Static tipping loads and operating weights shown are based on a machine configuration with Michelin 23.5R25 XHA2 L3 radial tires, full fluids, operator, cold start, roading fenders, Product Link, Manual Diff Lock/Open axles (front/rear), power train guard, secondary steering and sound suppression. (With Tire Deflection) Full compliance to ISO 14397-1 (2007) Sections 1 thru 6, which requires 2% verification between calculations and testing. (No Tire Deflection) Compliance to ISO 14397-1 (2007) Sections 1 thru 5.

NOTE: Machine and bucket availability varies by region. Consult your local dealer for availability.

Bucket Type Bucket Part Number	General Purpose — Pin On			Material Handling — Pin On			High Lift Delta	
	376-7800	376-7800	376-7800	354-4857	354-4857	354-4857		
Edge Type	Bolt-on Cutting Edges	Teeth & Segments	Tips	Bolt-on Cutting Edges	Teeth & Segments	Tips		
Capacity — rated	m ³ yd ³	3.80 4.97	3.80 4.97	3.60 4.71	2.70 3.53	2.70 3.53	2.50 3.27	— —
Capacity — 110%	m ³ yd ³	4.18 5.47	4.18 5.47	3.96 5.18	2.97 3.88	2.97 3.88	2.75 3.60	— —
Width	mm ft/in	2927 9'7"	2994 9'9"	2994 9'9"	2927 9'7"	2994 9'9"	2994 9'9"	— —
Dump clearance at maximum lift and 45° discharge	mm ft/in	2758 9'0"	2638 8'7"	2638 8'7"	2896 9'6"	2770 9'1"	2770 9'1"	505 1'7"
Reach at maximum lift and 45° discharge	mm ft/in	1524 5'0"	1632 5'4"	1632 5'4"	1272 4'2"	1374 4'6"	1374 4'6"	36 1"
Reach at level lift arm and bucket level	mm ft/in	2842 9'3"	3003 9'10"	3003 9'10"	2581 8'5"	2742 8'11"	2742 8'11"	375 1'2"
Digging depth	mm in	90 3.5	90 3.5	60 2.3	90 3.5	90 3.5	60 2.3	4 0
Overall length	mm ft/in	8353 27'5"	8526 28'0"	8526 28'0"	8092 26'7"	8265 27'2"	8265 27'2"	583 1'10"
Overall height with bucket at maximum lift	mm ft/in	5678 18'8"	5678 18'8"	5678 18'8"	5618 18'6"	5618 18'6"	5618 18'6"	505 1'7"
Loader clearance circle with bucket at carry position	mm ft/in	13 854 45'6"	14 025 46'1"	14 025 46'1"	13 700 45'0"	13 868 45'6"	13 868 45'6"	393 1'3"
Static tipping load, straight (With Tire Deflection)*	kg lb	12 435 27,408	12 292 27,091	12 562 27,687	12 832 28,282	12 695 27,980	13 023 28,703	-1277 -2815
Static tipping load, straight (No Tire Deflection)*	kg lb	13 182 29,054	13 037 28,734	13 314 29,344	13 548 29,861	13 409 29,555	13 748 30,301	-1436 -3166
Static tipping load, articulated (With Tire Deflection)*	kg lb	10 685 23,551	10 542 23,234	10 795 23,792	11 075 24,410	10 938 24,108	11 248 24,792	-1184 -2610
Static tipping load, articulated (No Tire Deflection)*	kg lb	11 446 25,228	11 301 24,908	11 560 25,478	11 806 26,021	11 667 25,716	11 988 26,422	-1334 -2941
Breakout force	kN lbf	160 35,985	158 35,705	172 38,748	198 44,633	197 44,343	217 48,847	-9 -20
Operating weight*	kg lb	19 398 42,753	19 506 42,991	19 349 42,645	19 115 42,128	19 223 42,366	19 066 42,020	602 1327

*Static tipping loads and operating weights shown are based on a machine configuration with Michelin 23.5R25 XHA2 L3 radial tires, full fluids, operator, cold start, roading fenders, Product Link, Manual Diff Lock/Open axles (front/rear), power train guard, secondary steering and sound suppression. (With Tire Deflection) Full compliance to ISO 14397-1 (2007) Sections 1 thru 6, which requires 2% verification between calculations and testing. (No Tire Deflection) Compliance to ISO 14397-1 (2007) Sections 1 thru 5.

NOTE: Machine and bucket availability varies by region. Consult your local dealer for availability.

Bucket Type	Material Handling — Pin On							High Lift Delta
	Bucket Part Number	354-4859	354-4859	354-4859	354-4861	354-4861	354-4861	
Edge Type		Bolt-on Cutting Edges	Teeth & Segments	Tips	Bolt-on Cutting Edges	Teeth & Segments	Tips	
Capacity — rated	m ³	2.90	2.90	2.70	3.10	3.10	2.90	—
	yd ³	3.79	3.79	3.53	4.05	4.05	3.79	—
Capacity — 110%	m ³	3.19	3.19	2.97	3.41	3.41	3.19	—
	yd ³	4.17	4.17	3.88	4.46	4.46	4.17	—
Width	mm	2927	2994	2994	2927	2994	2994	—
	ft/in	9'7"	9'9"	9'9"	9'7"	9'9"	9'9"	—
Dump clearance at maximum lift and 45° discharge	mm	2853	2728	2728	2821	2696	2696	505
	ft/in	9'4"	8'11"	8'11"	9'3"	8'10"	8'10"	1'7"
Reach at maximum lift and 45° discharge	mm	1314	1416	1416	1346	1448	1448	36
	ft/in	4'3"	4'7"	4'7"	4'5"	4'9"	4'9"	1"
Reach at level lift arm and bucket level	mm	2641	2802	2802	2686	2847	2847	375
	ft/in	8'8"	9'2"	9'2"	8'9"	9'4"	9'4"	1'2"
Digging depth	mm	90	90	60	90	90	60	4
	in	3.5	3.5	2.3	3.5	3.5	2.3	0
Overall length	mm	8152	8325	8325	8197	8370	8370	583
	ft/in	26'9"	27'4"	27'4"	26'11"	27'6"	27'6"	1'10"
Overall height with bucket at maximum lift	mm	4975	4975	4975	5483	5483	5483	505
	ft/in	16'4"	16'4"	16'4"	18'0"	18'0"	18'0"	1'7"
Loader clearance circle with bucket at carry position	mm	13 734	13 903	13 903	13 761	13 930	13 930	393
	ft/in	45'1"	45'8"	45'8"	45'2"	45'9"	45'9"	1'3"
Static tipping load, straight (With Tire Deflection)*	kg	12 717	12 578	12 862	12 624	12 484	12 763	-1277
	lb	28,028	27,723	28,349	27,823	27,516	28,129	-2815
Static tipping load, straight (No Tire Deflection)*	kg	13 436	13 296	13 586	13 345	13 204	13 488	-1436
	lb	29,613	29,304	29,944	29,412	29,102	29,729	-3166
Static tipping load, articulated (With Tire Deflection)*	kg	10 966	10 828	11 094	10 878	10 738	11 000	-1184
	lb	24,170	23,864	24,453	23,975	23,668	24,244	-2610
Static tipping load, articulated (No Tire Deflection)*	kg	11 700	11 560	11 833	11 613	11 472	11 739	-1334
	lb	25,786	25,478	26,080	25,596	25,286	25,874	-2941
Breakout force	kN	188	187	205	181	180	197	-9
	lbf	42,340	42,054	46,135	40,745	40,460	44,264	-20
Operating weight*	kg	19 171	19 279	19 122	19 221	19 329	19 172	602
	lb	42,252	42,490	42,144	42,362	42,600	42,254	1327

*Static tipping loads and operating weights shown are based on a machine configuration with Michelin 23.5R25 XHA2 L3 radial tires, full fluids, operator, cold start, roading fenders, Product Link, Manual Diff Lock/Open axles (front/rear), power train guard, secondary steering and sound suppression. (With Tire Deflection) Full compliance to ISO 14397-1 (2007) Sections 1 thru 6, which requires 2% verification between calculations and testing. (No Tire Deflection) Compliance to ISO 14397-1 (2007) Sections 1 thru 5.

NOTE: Machine and bucket availability varies by region. Consult your local dealer for availability.

Bucket Type Bucket Part Number	Material Handling — Pin On						High Lift Delta	
	354-4863	354-4863	354-4863	354-4865	354-4865	354-4865		
Edge Type	Bolt-on Cutting Edges	Teeth & Segments	Tips	Bolt-on Cutting Edges	Teeth & Segments	Tips		
Capacity — rated	m ³ yd ³	3.30 4.32	3.30 4.32	3.10 4.05	3.40 4.45	3.40 4.45	3.20 4.19	— —
Capacity — 110%	m ³ yd ³	3.63 4.75	3.63 4.75	3.41 4.46	3.74 4.89	3.74 4.89	3.52 4.60	— —
Width	mm ft/in	2927 9'7"	2994 9'9"	2994 9'9"	2927 9'7"	2994 9'9"	2994 9'9"	— —
Dump clearance at maximum lift and 45° discharge	mm ft/in	2789 9'1"	2664 8'8"	2664 8'8"	2761 9'0"	2636 8'7"	2636 8'7"	505 1'7"
Reach at maximum lift and 45° discharge	mm ft/in	1378 4'6"	1480 4'10"	1480 4'10"	1406 4'7"	1508 4'11"	1508 4'11"	36 1"
Reach at level lift arm and bucket level	mm ft/in	2731 9'11"	2892 9'5"	2892 9'5"	2771 9'1"	2932 9'7"	2932 9'7"	375 1'2"
Digging depth	mm in	90 3.5	90 3.5	60 2.3	90 3.5	90 3.5	60 2.3	4 0
Overall length	mm ft/in	8242 27'1"	8415 27'8"	8415 27'8"	8282 27'3"	8455 27'9"	8455 27'9"	583 1'10"
Overall height with bucket at maximum lift	mm ft/in	5527 18'2"	5527 18'2"	5527 18'2"	5566 18'4"	5566 18'4"	5566 18'4"	505 1'7"
Loader clearance circle with bucket at carry position	mm ft/in	13 787 45'3"	13 957 45'10"	13 957 45'10"	13 811 45'4"	13 981 45'11"	13 981 45'11"	393 1'3"
Static tipping load, straight (With Tire Deflection)*	kg lb	12 533 27,623	12 393 27,314	12 667 27,919	12 454 27,449	12 313 27,139	12 584 27,736	-1277 -2815
Static tipping load, straight (No Tire Deflection)*	kg lb	13 256 29,216	13 114 28,904	13 395 29,522	13 179 29,046	13 036 28,733	13 313 29,343	-1436 -3166
Static tipping load, articulated (With Tire Deflection)*	kg lb	10 791 23,784	10 651 23,475	10 909 24,044	10 716 23,619	10 575 23,309	10 830 23,870	-1184 -2610
Static tipping load, articulated (No Tire Deflection)*	kg lb	11 528 25,409	11 387 25,097	11 650 25,678	11 456 25,249	11 313 24,935	11 573 25,508	-1334 -2941
Breakout force	kN lbf	174 39,259	173 38,975	189 42,530	169 38,019	167 37,737	182 41,092	-9 -20
Operating weight*	kg lb	19 269 42,468	19 377 42,706	19 220 42,360	19 309 42,556	19 417 42,794	19 260 42,448	602 1327

*Static tipping loads and operating weights shown are based on a machine configuration with Michelin 23.5R25 XHA2 L3 radial tires, full fluids, operator, cold start, roading fenders, Product Link, Manual Diff Lock/Open axles (front/rear), power train guard, secondary steering and sound suppression. (With Tire Deflection) Full compliance to ISO 14397-1 (2007) Sections 1 thru 6, which requires 2% verification between calculations and testing. (No Tire Deflection) Compliance to ISO 14397-1 (2007) Sections 1 thru 5.

NOTE: Machine and bucket availability varies by region. Consult your local dealer for availability.

Bucket Type	Material Handling — Pin On							High Lift Delta
	Bucket Part Number	367-5733	367-5733	367-5733	354-4867	354-4867	354-4867	
Edge Type		Bolt-on Cutting Edges	Teeth & Segments	Tips	Bolt-on Cutting Edges	Teeth & Segments	Tips	
Capacity — rated	m ³	3.60	3.60	3.40	3.80	3.80	3.60	—
	yd ³	4.71	4.71	4.45	4.97	4.97	4.71	—
Capacity — 110%	m ³	3.96	3.96	3.74	4.18	4.18	3.96	—
	yd ³	5.18	5.18	4.89	5.47	5.47	5.18	—
Width	mm	2927	2994	2994	2927	2994	2994	—
	ft/in	9'7"	9'9"	9'9"	9'7"	9'9"	9'9"	—
Dump clearance at maximum lift and 45° discharge	mm	2729	2604	2604	2693	2568	2568	505
	ft/in	8'11"	8'6"	8'6"	8'10"	8'5"	8'5"	1'7"
Reach at maximum lift and 45° discharge	mm	1438	1540	1540	1474	1576	1576	36
	ft/in	4'8"	5'0"	5'0"	4'10"	5'2"	5'2"	1"
Reach at level lift arm and bucket level	mm	2816	2977	2977	2867	3028	3028	375
	ft/in	9'2"	9'9"	9'9"	9'4"	9'11"	9'11"	1'2"
Digging depth	mm	90	90	60	90	90	60	4
	in	3.5	3.5	2.3	3.5	3.5	2.3	0
Overall length	mm	8327	8500	8500	8378	8551	8551	583
	ft/in	27'4"	27'11"	27'11"	27'6"	28'1"	28'1"	1'10"
Overall height with bucket at maximum lift	mm	5614	5614	5614	5662	5662	5662	505
	ft/in	18'6"	18'6"	18'6"	18'7"	18'7"	18'7"	1'7"
Loader clearance circle with bucket at carry position	mm	13 838	14 009	14 009	13 869	14 041	14 041	393
	ft/in	45'5"	46'0"	46'0"	45'6"	46'1"	46'1"	1'3"
Static tipping load, straight (With Tire Deflection)*	kg	12 366	12 225	12 492	12 264	12 122	12 385	-1277
	lb	27,256	26,944	27,533	27,031	26,717	27,296	-2815
Static tipping load, straight (No Tire Deflection)*	kg	13 093	12 950	13 222	12 993	12 848	13 117	-1436
	lb	28,857	28,542	29,143	28,636	28,318	28,911	-3166
Static tipping load, articulated (With Tire Deflection)*	kg	10 633	10 491	10 742	10 536	10 393	10 640	-1184
	lb	23,436	23,124	23,677	23,222	22,907	23,452	-2610
Static tipping load, articulated (No Tire Deflection)*	kg	11 374	11 231	11 487	11 279	11 135	11 387	-1334
	lb	25,069	24,754	25,318	24,859	24,541	25,097	-2941
Breakout force	kN	163	162	176	157	155	169	-9
	lbf	36,707	36,426	39,578	35,309	35,029	37,973	-20
Operating weight*	kg	19 353	19 461	19 304	19 407	19 515	19 358	602
	lb	42,653	42,891	42,545	42,772	43,010	42,664	1327

*Static tipping loads and operating weights shown are based on a machine configuration with Michelin 23.5R25 XHA2 L3 radial tires, full fluids, operator, cold start, roading fenders, Product Link, Manual Diff Lock/Open axles (front/rear), power train guard, secondary steering and sound suppression. (With Tire Deflection) Full compliance to ISO 14397-1 (2007) Sections 1 thru 6, which requires 2% verification between calculations and testing. (No Tire Deflection) Compliance to ISO 14397-1 (2007) Sections 1 thru 5.

NOTE: Machine and bucket availability varies by region. Consult your local dealer for availability.

Bucket Type Bucket Part Number	General Purpose — Hook On							High Lift Delta
	354-4850	354-4850	354-4850	354-4852	354-4852	354-4852		
Edge Type	Bolt-on Cutting Edges	Teeth & Segments	Tips	Bolt-on Cutting Edges	Teeth & Segments	Tips		
Capacity — rated	m ³ yd ³	2.70 3.53	2.70 3.53	2.50 3.27	2.90 3.79	2.90 3.79	2.70 3.53	— —
Capacity — 110%	m ³ yd ³	2.97 3.88	2.97 3.88	2.75 3.60	3.19 4.17	3.19 4.17	2.97 3.88	— —
Width	mm ft/in	2927 9'7"	2994 9'9"	2994 9'9"	2927 9'7"	2994 9'9"	2994 9'9"	— —
Dump clearance at maximum lift and 45° discharge	mm ft/in	2936 9'7"	2820 9'3"	2820 9'3"	2880 9'5"	2763 9'0"	2763 9'0"	505 1'7"
Reach at maximum lift and 45° discharge	mm ft/in	1402 4'7"	1516 4'11"	1516 4'11"	1440 4'8"	1552 5'1"	1552 5'1"	36 1"
Reach at level lift arm and bucket level	mm ft/in	2622 8'7"	2783 9'1"	2783 9'1"	2691 8'9"	2852 9'4"	2852 9'4"	375 1'2"
Digging depth	mm in	90 3.5	90 3.5	60 2.3	90 3.5	90 3.5	60 2.3	4 0
Overall length	mm ft/in	8133 26'9"	8306 27'4"	8306 27'4"	8202 26'11"	8375 27'6"	8375 27'6"	583 1'10"
Overall height with bucket at maximum lift	mm ft/in	5424 17'10"	5424 17'10"	5424 17'10"	5497 18'1"	5497 18'1"	5497 18'1"	505 1'7"
Loader clearance circle with bucket at carry position	mm ft/in	13 714 45'0"	13 884 45'7"	13 884 45'7"	13 755 45'2"	13 926 45'9"	13 926 45'9"	393 1'3"
Static tipping load, straight (With Tire Deflection)*	kg lb	12 407 27,346	12 269 27,042	12 604 27,779	12 293 27,095	12 154 26,788	12 485 27,518	-1277 -2815
Static tipping load, straight (No Tire Deflection)*	kg lb	13 130 28,940	12 991 28,633	13 338 29,398	13 020 28,696	12 879 28,386	13 222 29,143	-1436 -3166
Static tipping load, articulated (With Tire Deflection)*	kg lb	10 658 23,490	10 520 23,187	10 835 23,882	10 549 23,250	10 410 22,943	10 722 23,633	-1184 -2610
Static tipping load, articulated (No Tire Deflection)*	kg lb	11 396 25,116	11 256 24,810	11 584 25,532	11 290 24,883	11 149 24,573	11 474 25,290	-1334 -2941
Breakout force	kN lbf	191 43,055	190 42,767	209 46,976	180 40,598	179 40,313	196 44,090	-9 -20
Operating weight*	kg lb	19 567 43,124	19 675 43,362	19 518 43,016	19 629 43,263	19 737 43,501	19 580 43,155	602 1327

*Static tipping loads and operating weights shown are based on a machine configuration with Michelin 23.5R25 XHA2 L3 radial tires, full fluids, operator, cold start, roading fenders, Product Link, Manual Diff Lock/Open axles (front/rear), power train guard, secondary steering and sound suppression. (With Tire Deflection) Full compliance to ISO 14397-1 (2007) Sections 1 thru 6, which requires 2% verification between calculations and testing. (No Tire Deflection) Compliance to ISO 14397-1 (2007) Sections 1 thru 5.

NOTE: Machine and bucket availability varies by region. Consult your local dealer for availability.

Bucket Type Bucket Part Number		General Purpose — Hook On						High Lift Delta
		348-0242	348-0242	348-0242	348-0243	348-0243	348-0243	
Edge Type		Bolt-on Cutting Edges	Teeth & Segments	Tips	Bolt-on Cutting Edges	Teeth & Segments	Tips	
Capacity — rated	m ³	3.10	3.10	2.90	3.30	3.30	3.10	—
	yd ³	4.05	4.05	3.79	4.32	4.32	4.05	—
Capacity — 110%	m ³	3.41	3.41	3.19	3.63	3.63	3.41	—
	yd ³	4.46	4.46	4.17	4.75	4.75	4.46	—
Width	mm	2927	2994	2994	2927	2994	2994	—
	ft/in	9'7"	9'9"	9'9"	9'7"	9'9"	9'9"	—
Dump clearance at maximum lift and 45° discharge	mm	2837	2718	2718	2798	2679	2679	505
	ft/in	9'3"	8'11"	8'11"	9'2"	8'9"	8'9"	1'7"
Reach at maximum lift and 45° discharge	mm	1475	1585	1585	1503	1613	1613	36
	ft/in	4'10"	5'2"	5'2"	4'11"	5'3"	5'3"	1"
Reach at level lift arm and bucket level	mm	2748	2909	2909	2797	2958	2958	375
	ft/in	9'0"	9'6"	9'6"	9'2"	9'8"	9'8"	1'2"
Digging depth	mm	90	90	60	90	90	60	4
	in	3.5	3.5	2.3	3.5	3.5	2.3	0
Overall length	mm	8259	8432	8432	8308	8481	8481	583
	ft/in	27'2"	27'8"	27'8"	27'4"	27'10"	27'10"	1'10"
Overall height with bucket at maximum lift	mm	5558	5558	5558	5604	5604	5604	505
	ft/in	18'3"	18'3"	18'3"	18'5"	18'5"	18'5"	1'7"
Loader clearance circle with bucket at carry position	mm	13 789	13 961	13 961	13 818	13 991	13 991	393
	ft/in	45'3"	45'10"	45'10"	45'5"	45'11"	45'11"	1'3"
Static tipping load, straight (With Tire Deflection)*	kg	12 183	12 043	12 373	12 093	11 952	12 281	-1277
	lb	26,853	26,544	27,271	26,654	26,343	27,067	-2815
Static tipping load, straight (No Tire Deflection)*	kg	12 913	12 771	13 113	12 825	12 682	13 023	-1436
	lb	28,461	28,148	28,902	28,267	27,952	28,703	-3166
Static tipping load, articulated (With Tire Deflection)*	kg	10 445	10 305	10 617	10 359	10 218	10 529	-1184
	lb	23,022	22,713	23,400	22,833	22,522	23,207	-2610
Static tipping load, articulated (No Tire Deflection)*	kg	11 189	11 047	11 371	11 106	10 963	11 286	-1334
	lb	24,661	24,349	25,063	24,477	24,163	24,874	-2941
Breakout force	kN	172	171	186	165	164	179	-9
	lbf	38,754	38,471	41,942	37,284	37,003	40,241	-20
Operating weight*	kg	19 683	19 791	19 634	19 730	19 838	19 681	602
	lb	43,382	43,620	43,274	43,484	43,722	43,376	1327

*Static tipping loads and operating weights shown are based on a machine configuration with Michelin 23.5R25 XHA2 L3 radial tires, full fluids, operator, cold start, roading fenders, Product Link, Manual Diff Lock/Open axles (front/rear), power train guard, secondary steering and sound suppression. (With Tire Deflection) Full compliance to ISO 14397-1 (2007) Sections 1 thru 6, which requires 2% verification between calculations and testing. (No Tire Deflection) Compliance to ISO 14397-1 (2007) Sections 1 thru 5.

NOTE: Machine and bucket availability varies by region. Consult your local dealer for availability.

Bucket Type Bucket Part Number	General Purpose — Hook On						High Lift Delta	
	354-4854	354-4854	354-4854	354-4856	354-4856	354-4856		
Edge Type	Bolt-on Cutting Edges	Teeth & Segments	Tips	Bolt-on Cutting Edges	Teeth & Segments	Tips		
Capacity — rated	m ³ yd ³	3.40 4.45	3.40 4.45	3.20 4.19	3.60 4.71	3.60 4.71	3.40 4.45	— —
Capacity — 110%	m ³ yd ³	3.74 4.89	3.74 4.89	3.52 4.60	3.96 5.18	3.96 5.18	3.74 4.89	— —
Width	mm ft/in	2927 9'7"	2994 9'9"	2994 9'9"	2927 9'7"	2994 9'9"	2994 9'9"	— —
Dump clearance at maximum lift and 45° discharge	mm ft/in	2779 9'1"	2660 8'8"	2660 8'8"	2753 9'0"	2633 8'7"	2633 8'7"	505 1'7"
Reach at maximum lift and 45° discharge	mm ft/in	1518 4'11"	1627 5'4"	1627 5'4"	1539 5'0"	1648 5'4"	1648 5'4"	36 1"
Reach at level lift arm and bucket level	mm ft/in	2821 9'3"	2982 9'9"	2982 9'9"	2856 9'4"	3017 9'10"	3017 9'10"	375 1'2"
Digging depth	mm in	90 3.5	90 3.5	60 2.3	90 3.5	90 3.5	60 2.3	4 0
Overall length	mm ft/in	8332 27'5"	8505 27'11"	8505 27'11"	8367 27'6"	8540 28'1"	8540 28'1"	583 1'10"
Overall height with bucket at maximum lift	mm ft/in	5630 18'6"	5630 18'6"	5630 18'6"	5664 18'7"	5664 18'7"	5664 18'7"	505 1'7"
Loader clearance circle with bucket at carry position	mm ft/in	13 833 45'5"	14 006 46'0"	14 006 46'0"	13 854 45'6"	14 028 46'1"	14 028 46'1"	393 1'3"
Static tipping load, straight (With Tire Deflection)*	kg lb	12 051 26,561	11 909 26,249	12 237 26,971	11 986 26,417	11 843 26,103	12 170 26,824	-1277 -2815
Static tipping load, straight (No Tire Deflection)*	kg lb	12 784 28,176	12 641 27,860	12 981 28,610	12 720 28,035	12 576 27,718	12 915 28,466	-1436 -3166
Static tipping load, articulated (With Tire Deflection)*	kg lb	10 319 22,744	10 178 22,432	10 488 23,116	10 257 22,607	10 115 22,294	10 425 22,976	-1184 -2610
Static tipping load, articulated (No Tire Deflection)*	kg lb	11 066 24,391	10 923 24,075	11 245 24,785	11 006 24,257	10 862 23,940	11 183 24,649	-1334 -2941
Breakout force	kN lbf	162 36,598	161 36,318	175 39,451	158 35,639	157 35,359	170 38,348	-9 -20
Operating weight*	kg lb	19 753 43,536	19 861 43,774	19 704 43,428	19 787 43,611	19 895 43,849	19 738 43,503	602 1327

*Static tipping loads and operating weights shown are based on a machine configuration with Michelin 23.5R25 XHA2 L3 radial tires, full fluids, operator, cold start, roading fenders, Product Link, Manual Diff Lock/Open axles (front/rear), power train guard, secondary steering and sound suppression. (With Tire Deflection) Full compliance to ISO 14397-1 (2007) Sections 1 thru 6, which requires 2% verification between calculations and testing. (No Tire Deflection) Compliance to ISO 14397-1 (2007) Sections 1 thru 5.

NOTE: Machine and bucket availability varies by region. Consult your local dealer for availability.

Bucket Type Bucket Part Number	General Purpose — Hook On			Material Handling — Hook On			High Lift Delta	
	376-7801	376-7801	376-7801	354-4858	354-4858	354-4858		
Edge Type	Bolt-on Cutting Edges	Teeth & Segments	Tips	Bolt-on Cutting Edges	Teeth & Segments	Tips		
Capacity — rated	m ³ yd ³	3.80 4.97	3.80 4.97	3.60 4.71	2.70 3.53	2.70 3.53	2.50 3.27	— —
Capacity — 110%	m ³ yd ³	4.18 5.47	4.18 5.47	3.96 5.18	2.97 3.88	2.97 3.88	2.75 3.60	— —
Width	mm ft/in	2927 9'7"	2994 9'9"	2994 9'9"	2927 9'7"	2994 9'9"	2994 9'9"	— —
Dump clearance at maximum lift and 45° discharge	mm ft/in	2718 8'11"	2598 8'6"	2598 8'6"	2853 9'4"	2728 8'11"	2728 8'11"	505 1'7"
Reach at maximum lift and 45° discharge	mm ft/in	1568 5'1"	1677 5'6"	1677 5'6"	1314 4'3"	1416 4'7"	1416 4'7"	36 1"
Reach at level lift arm and bucket level	mm ft/in	2902 9'6"	3063 10'0"	3063 10'0"	2641 8'8"	2802 9'2"	2802 9'2"	375 1'2"
Digging depth	mm in	90 3.5	90 3.5	60 2.3	90 3.5	90 3.5	60 2.3	4 0
Overall length	mm ft/in	8413 27'8"	8586 28'3"	8586 28'3"	8152 26'9"	8325 27'4"	8325 27'4"	583 1'10"
Overall height with bucket at maximum lift	mm ft/in	5711 18'9"	5711 18'9"	5711 18'9"	5418 17'10"	5418 17'10"	5418 17'10"	505 1'7"
Loader clearance circle with bucket at carry position	mm ft/in	13 883 45'7"	14 057 46'2"	14 057 46'2"	13 725 45'1"	13 895 45'8"	13 895 45'8"	393 1'3"
Static tipping load, straight (With Tire Deflection)*	kg lb	11 899 26,227	11 756 25,912	12 082 26,630	12 263 27,027	12 126 26,726	12 445 27,430	-1277 -2815
Static tipping load, straight (No Tire Deflection)*	kg lb	12 636 27,850	12 491 27,531	12 829 28,276	12 970 28,586	12 831 28,281	13 161 29,008	-1436 -3166
Static tipping load, articulated (With Tire Deflection)*	kg lb	10 175 22,427	10 032 22,111	10 341 22,792	10 532 23,213	10 395 22,911	10 698 23,579	-1184 -2610
Static tipping load, articulated (No Tire Deflection)*	kg lb	10 926 24,081	10 781 23,762	11 102 24,469	11 254 24,804	11 116 24,500	11 428 25,189	-1334 -2941
Breakout force	kN lbf	153 34,442	152 34,164	164 36,981	188 42,345	187 42,059	205 46,141	-9 -20
Operating weight*	kg lb	19 832 43,710	19 940 43,948	19 783 43,602	19 573 43,137	19 681 43,375	19 524 43,029	602 1327

*Static tipping loads and operating weights shown are based on a machine configuration with Michelin 23.5R25 XHA2 L3 radial tires, full fluids, operator, cold start, roading fenders, Product Link, Manual Diff Lock/Open axles (front/rear), power train guard, secondary steering and sound suppression. (With Tire Deflection) Full compliance to ISO 14397-1 (2007) Sections 1 thru 6, which requires 2% verification between calculations and testing. (No Tire Deflection) Compliance to ISO 14397-1 (2007) Sections 1 thru 5.

NOTE: Machine and bucket availability varies by region. Consult your local dealer for availability.

Bucket Type	Material Handling — Hook On							High Lift Delta
	Bucket Part Number	354-4860	354-4860	354-4860	354-4862	354-4862	354-4862	
Edge Type		Bolt-on Cutting Edges	Teeth & Segments	Tips	Bolt-on Cutting Edges	Teeth & Segments	Tips	
Capacity — rated	m ³	2.90	2.90	2.70	3.10	3.10	2.90	—
	yd ³	3.79	3.79	3.53	4.05	4.05	3.79	—
Capacity — 110%	m ³	3.19	3.19	2.97	3.41	3.41	3.19	—
	yd ³	4.17	4.17	3.88	4.46	4.46	4.17	—
Width	mm	2927	2994	2994	2927	2994	2994	—
	ft/in	9'7"	9'9"	9'9"	9'7"	9'9"	9'9"	—
Dump clearance at maximum lift and 45° discharge	mm	2811	2685	2685	2779	2653	2653	505
	ft/in	9'2"	8'9"	8'9"	9'1"	8'8"	8'8"	1'7"
Reach at maximum lift and 45° discharge	mm	1357	1459	1459	1389	1491	1491	36
	ft/in	4'5"	4'9"	4'9"	4'6"	4'10"	4'10"	1"
Reach at level lift arm and bucket level	mm	2701	2862	2862	2746	2907	2907	375
	ft/in	8'10"	9'4"	9'4"	9'0"	9'6"	9'6"	1'2"
Digging depth	mm	90	90	60	90	90	60	4
	in	3.5	3.5	2.3	3.5	3.5	2.3	0
Overall length	mm	8212	8385	8385	8257	8430	8430	583
	ft/in	27'0"	27'7"	27'7"	27'2"	27'8"	27'8"	1'10"
Overall height with bucket at maximum lift	mm	5480	5480	5480	5517	5517	5517	505
	ft/in	18'0"	18'0"	18'0"	18'2"	18'2"	18'2"	1'7"
Loader clearance circle with bucket at carry position	mm	13 761	13 932	13 932	13 788	13 959	13 959	393
	ft/in	45'2"	45'9"	45'9"	45'3"	45'10"	45'10"	1'3"
Static tipping load, straight (With Tire Deflection)*	kg	12 158	12 020	12 336	12 066	11 927	12 244	-1277
	lb	26,796	26,492	27,190	26,595	26,289	26,986	-2815
Static tipping load, straight (No Tire Deflection)*	kg	12 867	12 728	13 055	12 777	12 637	12 964	-1436
	lb	28,360	28,053	28,773	28,162	27,853	28,573	-3166
Static tipping load, articulated (With Tire Deflection)*	kg	10 433	10 295	10 595	10 346	10 207	10 507	-1184
	lb	22,994	22,690	23,352	22,803	22,497	23,159	-2610
Static tipping load, articulated (No Tire Deflection)*	kg	11 157	11 018	11 328	11 072	10 932	11 242	-1334
	lb	24,591	24,284	24,968	24,403	24,094	24,778	-2941
Breakout force	kN	179	177	194	172	171	186	-9
	lbf	40,263	39,978	43,698	38,805	38,522	42,002	-20
Operating weight*	kg	19 625	19 733	19 576	19 674	19 782	19 625	602
	lb	43,252	43,490	43,144	43,360	43,598	43,252	1327

*Static tipping loads and operating weights shown are based on a machine configuration with Michelin 23.5R25 XHA2 L3 radial tires, full fluids, operator, cold start, roading fenders, Product Link, Manual Diff Lock/Open axles (front/rear), power train guard, secondary steering and sound suppression. (With Tire Deflection) Full compliance to ISO 14397-1 (2007) Sections 1 thru 6, which requires 2% verification between calculations and testing. (No Tire Deflection) Compliance to ISO 14397-1 (2007) Sections 1 thru 5.

NOTE: Machine and bucket availability varies by region. Consult your local dealer for availability.

Bucket Type	Material Handling — Hook On							High Lift Delta
	Bucket Part Number	354-4864	354-4864	354-4864	354-4866	354-4866	354-4866	
Edge Type		Bolt-on Cutting Edges	Teeth & Segments	Tips	Bolt-on Cutting Edges	Teeth & Segments	Tips	
Capacity — rated	m ³	3.30	3.30	3.10	3.40	3.40	3.20	—
	yd ³	4.32	4.32	4.05	4.45	4.45	4.19	—
Capacity — 110%	m ³	3.63	3.63	3.41	3.74	3.74	3.52	—
	yd ³	4.75	4.75	4.46	4.89	4.89	4.60	—
Width	mm	2927	2994	2994	2927	2994	2994	—
	ft/in	9'7"	9'9"	9'9"	9'7"	9'9"	9'9"	—
Dump clearance at maximum lift and 45° discharge	mm	2747	2622	2622	2719	2593	2593	505
	ft/in	9'0"	8'7"	8'7"	8'11"	8'6"	8'6"	1'7"
Reach at maximum lift and 45° discharge	mm	1420	1523	1523	1449	1551	1551	36
	ft/in	4'7"	4'11"	4'11"	4'9"	5'1"	5'1"	1"
Reach at level lift arm and bucket level	mm	2791	2952	2952	2831	2992	2992	375
	ft/in	9'1"	9'8"	9'8"	9'3"	9'9"	9'9"	1'2"
Digging depth	mm	90	90	60	90	90	60	4
	in	3.5	3.5	2.3	3.5	3.5	2.3	0
Overall length	mm	8302	8475	8475	8342	8515	8515	583
	ft/in	27'3"	27'10"	27'10"	27'5"	28'0"	28'0"	1'10"
Overall height with bucket at maximum lift	mm	5561	5561	5561	5600	5600	5600	505
	ft/in	18'3"	18'3"	18'3"	18'5"	18'5"	18'5"	1'7"
Loader clearance circle with bucket at carry position	mm	13 815	13 987	13 987	13 839	14 012	14 012	393
	ft/in	45'4"	45'11"	45'11"	45'5"	46'0"	46'0"	1'3"
Static tipping load, straight (With Tire Deflection)*	kg	11 980	11 840	12 160	11 909	11 768	12 085	-1277
	lb	26,404	26,096	26,802	26,247	25,938	26,636	-2815
Static tipping load, straight (No Tire Deflection)*	kg	12 693	12 551	12 883	12 624	12 482	12 809	-1436
	lb	27,975	27,664	28,394	27,823	27,510	28,231	-3166
Static tipping load, articulated (With Tire Deflection)*	kg	10 264	10 124	10 428	10 196	10 056	10 357	-1184
	lb	22,622	22,315	22,983	22,473	22,164	22,826	-2610
Static tipping load, articulated (No Tire Deflection)*	kg	10 992	10 851	11 165	10 926	10 784	11 095	-1334
	lb	24,226	23,915	24,608	24,082	23,769	24,454	-2941
Breakout force	kN	166	165	179	161	160	174	-9
	lbf	37,446	37,165	40,429	36,309	36,029	39,119	-20
Operating weight*	kg	19 718	19 826	19 669	19 756	19 864	19 707	602
	lb	43,457	43,695	43,349	43,541	43,779	43,433	1327

*Static tipping loads and operating weights shown are based on a machine configuration with Michelin 23.5R25 XHA2 L3 radial tires, full fluids, operator, cold start, roading fenders, Product Link, Manual Diff Lock/Open axles (front/rear), power train guard, secondary steering and sound suppression. (With Tire Deflection) Full compliance to ISO 14397-1 (2007) Sections 1 thru 6, which requires 2% verification between calculations and testing. (No Tire Deflection) Compliance to ISO 14397-1 (2007) Sections 1 thru 5.

NOTE: Machine and bucket availability varies by region. Consult your local dealer for availability.

Bucket Type	Material Handling — Hook On							High Lift Delta
	Bucket Part Number	367-5735	367-5735	367-5735	354-4868	354-4868	354-4868	
Edge Type		Bolt-on Cutting Edges	Teeth & Segments	Tips	Bolt-on Cutting Edges	Teeth & Segments	Tips	
Capacity — rated	m ³	3.60	3.60	3.40	3.80	3.80	3.60	—
	yd ³	4.71	4.71	4.45	4.97	4.97	4.71	—
Capacity — 110%	m ³	3.96	3.96	3.74	4.18	4.18	3.96	—
	yd ³	5.18	5.18	4.89	5.47	5.47	5.18	—
Width	mm	2927	2994	2994	2927	2994	2994	—
	ft/in	9'7"	9'9"	9'9"	9'7"	9'9"	9'9"	—
Dump clearance at maximum lift and 45° discharge	mm	2687	2561	2561	2651	2525	2525	505
	ft/in	8'9"	8'4"	8'4"	8'8"	8'3"	8'3"	1'7"
Reach at maximum lift and 45° discharge	mm	1480	1583	1583	1517	1619	1619	36
	ft/in	4'10"	5'2"	5'2"	4'11"	5'3"	5'3"	1"
Reach at level lift arm and bucket level	mm	2876	3037	3037	2927	3088	3088	375
	ft/in	9'5"	9'11"	9'11"	9'7"	10'1"	10'1"	1'2"
Digging depth	mm	90	90	60	90	90	60	4
	in	3.5	3.5	2.3	3.5	3.5	2.3	0
Overall length	mm	8387	8560	8560	8438	8611	8611	583
	ft/in	27'7"	28'2"	28'2"	27'9"	28'4"	28'4"	1'10"
Overall height with bucket at maximum lift	mm	5643	5643	5643	5697	5697	5697	505
	ft/in	18'7"	18'7"	18'7"	18'9"	18'9"	18'9"	1'7"
Loader clearance circle with bucket at carry position	mm	13 867	14 040	14 040	13 898	14 073	14 073	393
	ft/in	45'6"	46'1"	46'1"	45'8"	46'3"	46'3"	1'3"
Static tipping load, straight (With Tire Deflection)*	kg	11 826	11 685	12 002	11 727	11 585	11 903	-1277
	lb	26,066	25,755	26,454	25,848	25,535	26,234	-2815
Static tipping load, straight (No Tire Deflection)*	kg	12 543	12 400	12 728	12 446	12 302	12 630	-1436
	lb	27,644	27,330	28,053	27,431	27,114	27,838	-3166
Static tipping load, articulated (With Tire Deflection)*	kg	10 119	9977	10 279	10 024	9882	10 184	-1184
	lb	22,302	21,991	22,655	22,094	21,781	22,445	-2610
Static tipping load, articulated (No Tire Deflection)*	kg	10 850	10 707	11 019	10 758	10 614	10 926	-1334
	lb	23,913	23,599	24,286	23,710	23,394	24,081	-2941
Breakout force	kN	156	155	167	150	149	161	-9
	lbf	35,106	34,827	37,739	33,811	33,533	36,262	-20
Operating weight*	kg	19 796	19 904	19 747	19 850	19 958	19 801	602
	lb	43,629	43,867	43,521	43,748	43,986	43,640	1327

*Static tipping loads and operating weights shown are based on a machine configuration with Michelin 23.5R25 XHA2 L3 radial tires, full fluids, operator, cold start, roading fenders, Product Link, Manual Diff Lock/Open axles (front/rear), power train guard, secondary steering and sound suppression. (With Tire Deflection) Full compliance to ISO 14397-1 (2007) Sections 1 thru 6, which requires 2% verification between calculations and testing. (No Tire Deflection) Compliance to ISO 14397-1 (2007) Sections 1 thru 5.

NOTE: Machine and bucket availability varies by region. Consult your local dealer for availability.

Bucket Type	General Purpose — Pin On						High Lift Delta	
	Bucket Part Number	354-4849	354-4849	354-4849	354-4851	354-4851		354-4851
Edge Type		Bolt-on Cutting Edges	Teeth & Segments	Tips	Bolt-on Cutting Edges	Teeth & Segments	Tips	
Capacity — rated	m ³	2.70	2.70	2.50	2.90	2.90	2.70	—
	yd ³	3.53	3.53	3.27	3.79	3.79	3.53	—
Capacity — 110%	m ³	2.97	2.97	2.75	3.19	3.19	2.97	—
	yd ³	3.88	3.88	3.60	4.17	4.17	3.88	—
Width	mm	2927	2994	2994	2927	2994	2994	—
	ft/in	9'7"	9'9"	9'9"	9'7"	9'9"	9'9"	—
Dump clearance at maximum lift and 45° discharge	mm	3191	3076	3076	3136	3019	3019	289
	ft/in	10'5"	10'1"	10'1"	10'3"	9'10"	9'10"	11"
Reach at maximum lift and 45° discharge	mm	1290	1403	1403	1328	1440	1440	101
	ft/in	4'2"	4'7"	4'7"	4'4"	4'8"	4'8"	3"
Reach at level lift arm and bucket level	mm	2660	2821	2821	2729	2890	2890	277
	ft/in	8'8"	9'3"	9'3"	8'11"	9'5"	9'5"	10"
Digging depth	mm	88	88	58	88	88	58	6
	in	3.5	3.5	2.3	3.5	3.5	2.3	0
Overall length	mm	8399	8571	8571	8468	8640	8640	372
	ft/in	27'7"	28'2"	28'2"	27'10"	28'5"	28'5"	1'2"
Overall height with bucket at maximum lift	mm	5609	5609	5609	5681	5681	5681	288
	ft/in	18'5"	18'5"	18'5"	18'8"	18'8"	18'8"	11"
Loader clearance circle with bucket at carry position	mm	13 785	13 953	13 953	13 825	13 995	13 995	308
	ft/in	45'3"	45'10"	45'10"	45'5"	45'11"	45'11"	1'0"
Static tipping load, straight (With Tire Deflection)*	kg	14 054	13 917	14 225	13 905	13 766	14 068	-631
	lb	30,975	30,673	31,353	30,647	30,342	31,006	-1391
Static tipping load, straight (No Tire Deflection)*	kg	14 787	14 649	14 966	14 641	14 502	14 811	-722
	lb	32,591	32,286	32,986	32,270	31,962	32,644	-1592
Static tipping load, articulated (With Tire Deflection)*	kg	12 066	11 929	12 217	11 923	11 785	12 066	-612
	lb	26,594	26,292	26,926	26,280	25,975	26,595	-1349
Static tipping load, articulated (No Tire Deflection)*	kg	12 820	12 682	12 978	12 681	12 541	12 830	-695
	lb	28,256	27,952	28,604	27,950	27,642	28,278	-1532
Breakout force	kN	219	218	241	206	205	225	-2
	lbf	49,349	49,114	54,147	46,405	46,170	50,653	-4
Operating weight*	kg	20 036	20 144	19 987	20 120	20 228	20 071	592
	lb	44,158	44,396	44,050	44,345	44,583	44,237	1305

*Static tipping loads and operating weights shown are based on a machine configuration with Michelin 23.5R25 XHA2 L3 radial tires, full fluids, operator, cold start, roading fenders, Product Link, Manual Diff Lock/Open axles (front/rear), power train guard, secondary steering and sound suppression. (With Tire Deflection) Full compliance to ISO 14397-1 (2007) Sections 1 thru 6, which requires 2% verification between calculations and testing. (No Tire Deflection) Compliance to ISO 14397-1 (2007) Sections 1 thru 5.

NOTE: Machine and bucket availability varies by region. Consult your local dealer for availability.

Bucket Type	General Purpose — Pin On							High Lift Delta
	Bucket Part Number	352-5537	352-5537	352-5537	352-5538	352-5538	352-5538	
Edge Type		Bolt-on Cutting Edges	Teeth & Segments	Tips	Bolt-on Cutting Edges	Teeth & Segments	Tips	
Capacity — rated	m ³	3.10	3.10	2.90	3.30	3.30	3.10	—
	yd ³	4.05	4.05	3.79	4.32	4.32	4.05	—
Capacity — 110%	m ³	3.41	3.41	3.19	3.63	3.63	3.41	—
	yd ³	4.46	4.46	4.17	4.75	4.75	4.46	—
Width	mm	2927	2994	2994	2927	2994	2994	—
	ft/in	9'7"	9'9"	9'9"	9'7"	9'9"	9'9"	—
Dump clearance at maximum lift and 45° discharge	mm	3093	2975	2975	3054	2936	2936	289
	ft/in	10'1"	9'9"	9'9"	10'0"	9'7"	9'7"	11"
Reach at maximum lift and 45° discharge	mm	1363	1474	1474	1392	1502	1502	101
	ft/in	4'5"	4'10"	4'10"	4'6"	4'11"	4'11"	3"
Reach at level lift arm and bucket level	mm	2786	2947	2947	2835	2996	2996	277
	ft/in	9'1"	9'8"	9'8"	9'3"	9'9"	9'9"	10"
Digging depth	mm	88	88	58	88	88	58	6
	in	3.5	3.5	2.3	3.5	3.5	2.3	0
Overall length	mm	8525	8697	8697	8574	8746	8746	372
	ft/in	28'0"	28'7"	28'7"	28'2"	28'9"	28'9"	1'2"
Overall height with bucket at maximum lift	mm	5742	5742	5742	5788	5788	5788	288
	ft/in	18'11"	18'11"	18'11"	19'0"	19'0"	19'0"	11"
Loader clearance circle with bucket at carry position	mm	13 859	14 029	14 029	13 888	14 059	14 059	308
	ft/in	45'6"	46'1"	46'1"	45'7"	46'2"	46'2"	1'0"
Static tipping load, straight (With Tire Deflection)*	kg	13 803	13 664	13 957	13 677	13 536	13 828	-631
	lb	30,423	30,116	30,763	30,144	29,834	30,477	-1391
Static tipping load, straight (No Tire Deflection)*	kg	14 543	14 402	14 703	14 418	14 276	14 575	-722
	lb	32,053	31,743	32,406	31,777	31,465	32,124	-1592
Static tipping load, articulated (With Tire Deflection)*	kg	11 829	11 690	11 964	11 709	11 568	11 840	-612
	lb	26,072	25,765	26,369	25,806	25,497	26,097	-1349
Static tipping load, articulated (No Tire Deflection)*	kg	12 590	12 449	12 730	12 471	12 329	12 608	-695
	lb	27,749	27,439	28,057	27,486	27,174	27,789	-1532
Breakout force	kN	196	195	214	189	188	204	-2
	lbf	44,238	44,003	48,103	42,483	42,248	46,055	-4
Operating weight*	kg	20 157	20 265	20 108	20 227	20 335	20 178	592
	lb	44,426	44,664	44,318	44,579	44,817	44,471	1305

*Static tipping loads and operating weights shown are based on a machine configuration with Michelin 23.5R25 XHA2 L3 radial tires, full fluids, operator, cold start, roading fenders, Product Link, Manual Diff Lock/Open axles (front/rear), power train guard, secondary steering and sound suppression. (With Tire Deflection) Full compliance to ISO 14397-1 (2007) Sections 1 thru 6, which requires 2% verification between calculations and testing. (No Tire Deflection) Compliance to ISO 14397-1 (2007) Sections 1 thru 5.

NOTE: Machine and bucket availability varies by region. Consult your local dealer for availability.

Bucket Type	General Purpose — Pin On							High Lift Delta
	Bucket Part Number	354-4853	354-4853	354-4853	354-4855	354-4855	354-4855	
Edge Type		Bolt-on Cutting Edges	Teeth & Segments	Tips	Bolt-on Cutting Edges	Teeth & Segments	Tips	
Capacity — rated	m ³	3.40	3.40	3.20	3.60	3.60	3.40	—
	yd ³	4.45	4.45	4.19	4.71	4.71	4.45	—
Capacity — 110%	m ³	3.74	3.74	3.52	3.96	3.96	3.74	—
	yd ³	4.89	4.89	4.60	5.18	5.18	4.89	—
Width	mm	2927	2994	2994	2927	2994	2994	—
	ft/in	9'7"	9'9"	9'9"	9'7"	9'9"	9'9"	—
Dump clearance at maximum lift and 45° discharge	mm	3036	2917	2917	3010	2890	2890	289
	ft/in	9'11"	9'6"	9'6"	9'10"	9'5"	9'5"	11"
Reach at maximum lift and 45° discharge	mm	1406	1516	1516	1428	1537	1537	101
	ft/in	4'7"	4'11"	4'11"	4'8"	5'0"	5'0"	3"
Reach at level lift arm and bucket level	mm	2859	3020	3020	2894	3055	3055	277
	ft/in	9'4"	9'10"	9'10"	9'5"	10'0"	10'0"	10"
Digging depth	mm	88	88	58	88	88	58	6
	in	3.5	3.5	2.3	3.5	3.5	2.3	0
Overall length	mm	8598	8770	8770	8633	8805	8805	372
	ft/in	28'3"	28'10"	28'10"	28'4"	28'11"	28'11"	1'2"
Overall height with bucket at maximum lift	mm	5813	5813	5813	5847	5847	5847	288
	ft/in	19'1"	19'1"	19'1"	19'3"	19'3"	19'3"	11"
Loader clearance circle with bucket at carry position	mm	13 903	14 074	14 074	13 924	14 095	14 095	308
	ft/in	45'8"	46'3"	46'3"	45'9"	46'3"	46'3"	1'0"
Static tipping load, straight (With Tire Deflection)*	kg	13 630	13 490	13 778	13 555	13 414	13 699	-631
	lb	30,042	29,732	30,368	29,877	29,565	30,193	-1391
Static tipping load, straight (No Tire Deflection)*	kg	14 373	14 231	14 526	14 299	14 156	14 448	-722
	lb	31,678	31,365	32,016	31,516	31,201	31,845	-1592
Static tipping load, articulated (With Tire Deflection)*	kg	11 665	11 524	11 793	11 594	11 452	11 718	-612
	lb	25,709	25,399	25,993	25,553	25,241	25,828	-1349
Static tipping load, articulated (No Tire Deflection)*	kg	12 428	12 286	12 562	12 359	12 216	12 488	-695
	lb	27,392	27,079	27,687	27,239	26,924	27,524	-1532
Breakout force	kN	185	184	200	180	179	195	-2
	lbf	41,675	41,440	45,117	40,547	40,311	43,810	-4
Operating weight*	kg	20 251	20 359	20 202	20 287	20 395	20 238	592
	lb	44,632	44,870	44,524	44,712	44,950	44,604	1305

*Static tipping loads and operating weights shown are based on a machine configuration with Michelin 23.5R25 XHA2 L3 radial tires, full fluids, operator, cold start, roading fenders, Product Link, Manual Diff Lock/Open axles (front/rear), power train guard, secondary steering and sound suppression. (With Tire Deflection) Full compliance to ISO 14397-1 (2007) Sections 1 thru 6, which requires 2% verification between calculations and testing. (No Tire Deflection) Compliance to ISO 14397-1 (2007) Sections 1 thru 5.

NOTE: Machine and bucket availability varies by region. Consult your local dealer for availability.

Bucket Type Bucket Part Number	General Purpose — Pin On			Material Handling — Pin On			High Lift Delta	
	376-7800	376-7800	376-7800	354-4857	354-4857	354-4857		
Edge Type	Bolt-on Cutting Edges	Teeth & Segments	Tips	Bolt-on Cutting Edges	Teeth & Segments	Tips		
Capacity — rated	m ³ yd ³	3.80 4.97	3.80 4.97	3.60 4.71	2.70 3.53	2.70 3.53	2.50 3.27	— —
Capacity — 110%	m ³ yd ³	4.18 5.47	4.18 5.47	3.96 5.18	2.97 3.88	2.97 3.88	2.75 3.60	— —
Width	mm ft/in	2927 9'7"	2994 9'9"	2994 9'9"	2927 9'7"	2994 9'9"	2994 9'9"	— —
Dump clearance at maximum lift and 45° discharge	mm ft/in	2975 9'9"	2855 9'4"	2855 9'4"	3112 10'2"	2987 9'9"	2987 9'9"	289 11"
Reach at maximum lift and 45° discharge	mm ft/in	1457 4'9"	1566 5'1"	1566 5'1"	1206 3'11"	1308 4'3"	1308 4'3"	101 3"
Reach at level lift arm and bucket level	mm ft/in	2940 9'7"	3101 10'2"	3101 10'2"	2679 8'9"	2840 9'3"	2840 9'3"	277 10"
Digging depth	mm in	88 3.5	88 3.5	58 2.3	88 3.5	88 3.5	58 2.3	6 0
Overall length	mm ft/in	8679 28'6"	8851 29'1"	8851 29'1"	8418 27'8"	8590 28'3"	8590 28'3"	372 1'2"
Overall height with bucket at maximum lift	mm ft/in	5894 19'5"	5894 19'5"	5894 19'5"	5835 19'2"	5835 19'2"	5835 19'2"	288 11"
Loader clearance circle with bucket at carry position	mm ft/in	13 952 45'10"	14 124 46'5"	14 124 46'5"	13 796 45'4"	13 965 45'10"	13 965 45'10"	308 1'0"
Static tipping load, straight (With Tire Deflection)*	kg lb	13 450 29,644	13 308 29,330	13 588 29,949	13 879 30,591	13 743 30,291	14 078 31,029	-631 -1391
Static tipping load, straight (No Tire Deflection)*	kg lb	14 195 31,287	14 052 30,970	14 339 31,604	14 596 32,170	14 459 31,868	14 804 32,628	-722 -1592
Static tipping load, articulated (With Tire Deflection)*	kg lb	11 494 25,333	11 352 25,019	11 613 25,597	11 912 26,255	11 776 25,955	12 092 26,651	-612 -1349
Static tipping load, articulated (No Tire Deflection)*	kg lb	12 260 27,023	12 117 26,706	12 385 27,296	12 650 27,882	12 513 27,579	12 838 28,297	-695 -1532
Breakout force	kN lbf	174 39,140	173 38,905	187 42,189	215 48,485	214 48,250	236 53,119	-2 -4
Operating weight*	kg lb	20 342 44,832	20 450 45,070	20 293 44,724	20 058 44,208	20 166 44,446	20 009 44,100	592 1305

*Static tipping loads and operating weights shown are based on a machine configuration with Michelin 23.5R25 XHA2 L3 radial tires, full fluids, operator, cold start, roading fenders, Product Link, Manual Diff Lock/Open axles (front/rear), power train guard, secondary steering and sound suppression. (With Tire Deflection) Full compliance to ISO 14397-1 (2007) Sections 1 thru 6, which requires 2% verification between calculations and testing. (No Tire Deflection) Compliance to ISO 14397-1 (2007) Sections 1 thru 5.

NOTE: Machine and bucket availability varies by region. Consult your local dealer for availability.

Bucket Type Bucket Part Number	Material Handling — Pin On						High Lift Delta	
	354-4859	354-4859	354-4859	354-4861	354-4861	354-4861		
Edge Type	Bolt-on Cutting Edges	Teeth & Segments	Tips	Bolt-on Cutting Edges	Teeth & Segments	Tips		
Capacity — rated	m ³ yd ³	2.90 3.79	2.90 3.79	2.70 3.53	3.10 4.05	3.10 4.05	2.90 3.79	— —
Capacity — 110%	m ³ yd ³	3.19 4.17	3.19 4.17	2.97 3.88	3.41 4.46	3.41 4.46	3.19 4.17	— —
Width	mm ft/in	2927 9'7"	2994 9'9"	2994 9'9"	2927 9'7"	2994 9'9"	2994 9'9"	— —
Dump clearance at maximum lift and 45° discharge	mm ft/in	3070 10'0"	2944 9'7"	2944 9'7"	3038 9'11"	2913 9'6"	2913 9'6"	289 11"
Reach at maximum lift and 45° discharge	mm ft/in	1248 4'1"	1350 4'5"	1350 4'5"	1280 4'2"	1382 4'6"	1382 4'6"	101 3"
Reach at level lift arm and bucket level	mm ft/in	2739 9'11"	2900 9'6"	2900 9'6"	2784 9'1"	2945 9'7"	2945 9'7"	277 10"
Digging depth	mm in	88 3.5	88 3.5	58 2.3	88 3.5	88 3.5	58 2.3	6 0
Overall length	mm ft/in	8478 27'10"	8650 28'5"	8650 28'5"	8523 28'0"	8695 28'7"	8695 28'7"	372 1'2"
Overall height with bucket at maximum lift	mm ft/in	5192 17'1"	5192 17'1"	5192 17'1"	5700 18'9"	5700 18'9"	5700 18'9"	288 11"
Loader clearance circle with bucket at carry position	mm ft/in	13 831 45'5"	14 001 46'0"	14 001 46'0"	13 858 45'6"	14 028 46'1"	14 028 46'1"	308 1'0"
Static tipping load, straight (With Tire Deflection)*	kg lb	13 756 30,319	13 619 30,016	13 913 30,664	13 658 30,102	13 519 29,797	13 807 30,432	-631 -1391
Static tipping load, straight (No Tire Deflection)*	kg lb	14 475 31,904	14 337 31,599	14 637 32,261	14 378 31,690	14 239 31,383	14 533 32,032	-722 -1592
Static tipping load, articulated (With Tire Deflection)*	kg lb	11 796 26,000	11 659 25,697	11 934 26,304	11 703 25,794	11 565 25,490	11 835 26,084	-612 -1349
Static tipping load, articulated (No Tire Deflection)*	kg lb	12 537 27,632	12 398 27,327	12 680 27,946	12 445 27,430	12 306 27,123	12 582 27,730	-695 -1532
Breakout force	kN lbf	204 46,006	203 45,771	223 50,183	197 44,283	196 44,048	214 48,158	-2 -4
Operating weight*	kg lb	20 114 44,331	20 222 44,569	20 065 44,223	20 164 44,442	20 272 44,680	20 115 44,334	592 1305

*Static tipping loads and operating weights shown are based on a machine configuration with Michelin 23.5R25 XHA2 L3 radial tires, full fluids, operator, cold start, roading fenders, Product Link, Manual Diff Lock/Open axles (front/rear), power train guard, secondary steering and sound suppression. (With Tire Deflection) Full compliance to ISO 14397-1 (2007) Sections 1 thru 6, which requires 2% verification between calculations and testing. (No Tire Deflection) Compliance to ISO 14397-1 (2007) Sections 1 thru 5.

NOTE: Machine and bucket availability varies by region. Consult your local dealer for availability.

Bucket Type Bucket Part Number	Material Handling — Pin On						High Lift Delta	
	354-4863	354-4863	354-4863	354-4865	354-4865	354-4865		
Edge Type	Bolt-on Cutting Edges	Teeth & Segments	Tips	Bolt-on Cutting Edges	Teeth & Segments	Tips		
Capacity — rated	m ³ yd ³	3.30 4.32	3.30 4.32	3.10 4.05	3.40 4.45	3.40 4.45	3.20 4.19	— —
Capacity — 110%	m ³ yd ³	3.63 4.75	3.63 4.75	3.41 4.46	3.74 4.89	3.74 4.89	3.52 4.60	— —
Width	mm ft/in	2927 9'7"	2994 9'9"	2994 9'9"	2927 9'7"	2994 9'9"	2994 9'9"	— —
Dump clearance at maximum lift and 45° discharge	mm ft/in	3006 9'10"	2881 9'5"	2881 9'5"	2978 9'9"	2852 9'4"	2852 9'4"	289 11"
Reach at maximum lift and 45° discharge	mm ft/in	1312 4'3"	1414 4'7"	1414 4'7"	1340 4'4"	1442 4'8"	1442 4'8"	101 3"
Reach at level lift arm and bucket level	mm ft/in	2829 9'3"	2990 9'9"	2990 9'9"	2869 9'4"	3030 9'11"	3030 9'11"	277 10"
Digging depth	mm in	88 3.5	88 3.5	58 2.3	88 3.5	88 3.5	58 2.3	6 0
Overall length	mm ft/in	8568 28'2"	8740 28'9"	8740 28'9"	8608 28'3"	8780 28'10"	8780 28'10"	372 1'2"
Overall height with bucket at maximum lift	mm ft/in	5744 18'11"	5744 18'11"	5744 18'11"	5783 19'0"	5783 19'0"	5783 19'0"	288 11"
Loader clearance circle with bucket at carry position	mm ft/in	13 885 45'7"	14 055 46'2"	14 055 46'2"	13 909 45'8"	14 080 46'3"	14 080 46'3"	308 1'0"
Static tipping load, straight (With Tire Deflection)*	kg lb	13 560 29,888	13 422 29,582	13 706 30,209	13 477 29,704	13 337 29,396	13 618 30,016	-631 -1391
Static tipping load, straight (No Tire Deflection)*	kg lb	14 283 31,480	14 143 31,171	14 434 31,812	14 201 31,299	14 060 30,989	14 347 31,622	-722 -1592
Static tipping load, articulated (With Tire Deflection)*	kg lb	11 611 25,592	11 472 25,286	11 739 25,873	11 533 25,418	11 393 25,111	11 656 25,691	-612 -1349
Static tipping load, articulated (No Tire Deflection)*	kg lb	12 356 27,232	12 215 26,924	12 487 27,523	12 278 27,062	12 137 26,751	12 406 27,343	-695 -1532
Breakout force	kN lbf	189 42,676	188 42,441	206 46,282	183 41,337	182 41,102	199 44,726	-2 -4
Operating weight*	kg lb	20 212 44,547	20 320 44,785	20 163 44,439	20 252 44,636	20 360 44,874	20 203 44,528	592 1305

*Static tipping loads and operating weights shown are based on a machine configuration with Michelin 23.5R25 XHA2 L3 radial tires, full fluids, operator, cold start, roading fenders, Product Link, Manual Diff Lock/Open axles (front/rear), power train guard, secondary steering and sound suppression. (With Tire Deflection) Full compliance to ISO 14397-1 (2007) Sections 1 thru 6, which requires 2% verification between calculations and testing. (No Tire Deflection) Compliance to ISO 14397-1 (2007) Sections 1 thru 5.

NOTE: Machine and bucket availability varies by region. Consult your local dealer for availability.

Bucket Type Bucket Part Number	Material Handling — Pin On						High Lift Delta	
	367-5733	367-5733	367-5733	354-4867	354-4867	354-4867		
Edge Type	Bolt-on Cutting Edges	Teeth & Segments	Tips	Bolt-on Cutting Edges	Teeth & Segments	Tips		
Capacity — rated	m ³ yd ³	3.60 4.71	3.60 4.71	3.40 4.45	3.80 4.97	3.80 4.97	3.60 4.71	— —
Capacity — 110%	m ³ yd ³	3.96 5.18	3.96 5.18	3.74 4.89	4.18 5.47	4.18 5.47	3.96 5.18	— —
Width	mm ft/in	2927 9'7"	2994 9'9"	2994 9'9"	2927 9'7"	2994 9'9"	2994 9'9"	— —
Dump clearance at maximum lift and 45° discharge	mm ft/in	2946 9'8"	2821 9'3"	2821 9'3"	2910 9'6"	2785 9'1"	2785 9'1"	289 11"
Reach at maximum lift and 45° discharge	mm ft/in	1372 4'6"	1474 4'10"	1474 4'10"	1408 4'7"	1510 4'11"	1510 4'11"	101 3"
Reach at level lift arm and bucket level	mm ft/in	2914 9'6"	3075 10'1"	3075 10'1"	2965 9'8"	3126 10'3"	3126 10'3"	277 10"
Digging depth	mm in	88 3.5	88 3.5	58 2.3	88 3.5	88 3.5	58 2.3	6 0
Overall length	mm ft/in	8653 28'5"	8825 29'0"	8825 29'0"	8704 28'7"	8876 29'2"	8876 29'2"	372 1'2"
Overall height with bucket at maximum lift	mm ft/in	5831 19'2"	5831 19'2"	5831 19'2"	5879 19'4"	5879 19'4"	5879 19'4"	288 11"
Loader clearance circle with bucket at carry position	mm ft/in	13 936 45'9"	14 108 46'4"	14 108 46'4"	13 967 45'10"	14 139 46'5"	14 139 46'5"	308 1'0"
Static tipping load, straight (With Tire Deflection)*	kg lb	13 383 29,498	13 243 29,188	13 520 29,799	13 275 29,258	13 134 28,947	13 407 29,550	-631 -1391
Static tipping load, straight (No Tire Deflection)*	kg lb	14 109 31,097	13 967 30,785	14 250 31,408	14 002 30,861	13 860 30,547	14 139 31,162	-722 -1592
Static tipping load, articulated (With Tire Deflection)*	kg lb	11 445 25,225	11 304 24,915	11 564 25,487	11 342 24,998	11 201 24,687	11 456 25,250	-612 -1349
Static tipping load, articulated (No Tire Deflection)*	kg lb	12 192 26,871	12 050 26,559	12 315 27,142	12 091 26,649	11 948 26,335	12 209 26,909	-695 -1532
Breakout force	kN lbf	177 39,919	176 39,684	191 43,087	170 38,410	169 38,174	184 41,351	-2 -4
Operating weight*	kg lb	20 296 44,732	20 404 44,970	20 247 44,624	20 350 44,851	20 458 45,089	20 301 44,743	592 1305

*Static tipping loads and operating weights shown are based on a machine configuration with Michelin 23.5R25 XHA2 L3 radial tires, full fluids, operator, cold start, roading fenders, Product Link, Manual Diff Lock/Open axles (front/rear), power train guard, secondary steering and sound suppression. (With Tire Deflection) Full compliance to ISO 14397-1 (2007) Sections 1 thru 6, which requires 2% verification between calculations and testing. (No Tire Deflection) Compliance to ISO 14397-1 (2007) Sections 1 thru 5.

NOTE: Machine and bucket availability varies by region. Consult your local dealer for availability.

Bucket Type	General Purpose — Hook On							High Lift Delta
	Bucket Part Number	354-4850	354-4850	354-4850	354-4852	354-4852	354-4852	
Edge Type		Bolt-on Cutting Edges	Teeth & Segments	Tips	Bolt-on Cutting Edges	Teeth & Segments	Tips	
Capacity — rated	m ³	2.70	2.70	2.50	2.90	2.90	2.70	—
	yd ³	3.53	3.53	3.27	3.79	3.79	3.53	—
Capacity — 110%	m ³	2.97	2.97	2.75	3.19	3.19	2.97	—
	yd ³	3.88	3.88	3.60	4.17	4.17	3.88	—
Width	mm	2927	2994	2994	2927	2994	2994	—
	ft/in	9'7"	9'9"	9'9"	9'7"	9'9"	9'9"	—
Dump clearance at maximum lift and 45° discharge	mm	3153	3037	3037	3097	2980	2980	289
	ft/in	10'4"	9'11"	9'11"	10'1"	9'9"	9'9"	11"
Reach at maximum lift and 45° discharge	mm	1336	1449	1449	1374	1485	1485	101
	ft/in	4'4"	4'9"	4'9"	4'6"	4'10"	4'10"	3"
Reach at level lift arm and bucket level	mm	2720	2881	2881	2789	2950	2950	277
	ft/in	8'11"	9'5"	9'5"	9'1"	9'8"	9'8"	10"
Digging depth	mm	88	88	58	88	88	58	6
	in	3.5	3.5	2.3	3.5	3.5	2.3	0
Overall length	mm	8459	8631	8631	8528	8700	8700	372
	ft/in	27'10"	28'4"	28'4"	28'0"	28'7"	28'7"	1'2"
Overall height with bucket at maximum lift	mm	5641	5641	5641	5714	5714	5714	288
	ft/in	18'7"	18'7"	18'7"	18'9"	18'9"	18'9"	11"
Loader clearance circle with bucket at carry position	mm	13 811	13 982	13 982	13 852	14 024	14 024	308
	ft/in	45'4"	45'11"	45'11"	45'6"	46'1"	46'1"	1'0"
Static tipping load, straight (With Tire Deflection)*	kg	13 441	13 305	13 645	13 320	13 182	13 519	-631
	lb	29,625	29,324	30,075	29,357	29,053	29,796	-1391
Static tipping load, straight (No Tire Deflection)*	kg	14 165	14 027	14 380	14 046	13 907	14 256	-722
	lb	31,219	30,916	31,693	30,958	30,651	31,421	-1592
Static tipping load, articulated (With Tire Deflection)*	kg	11 483	11 346	11 666	11 368	11 230	11 547	-612
	lb	25,309	25,008	25,713	25,055	24,751	25,450	-1349
Static tipping load, articulated (No Tire Deflection)*	kg	12 228	12 090	12 422	12 116	11 976	12 305	-695
	lb	26,951	26,648	27,379	26,704	26,397	27,122	-1532
Breakout force	kN	208	207	227	196	195	213	-2
	lbf	46,777	46,543	51,093	44,122	43,887	47,968	-4
Operating weight*	kg	20 510	20 618	20 461	20 573	20 681	20 524	592
	lb	45,204	45,442	45,096	45,342	45,580	45,234	1305

*Static tipping loads and operating weights shown are based on a machine configuration with Michelin 23.5R25 XHA2 L3 radial tires, full fluids, operator, cold start, roading fenders, Product Link, Manual Diff Lock/Open axles (front/rear), power train guard, secondary steering and sound suppression. (With Tire Deflection) Full compliance to ISO 14397-1 (2007) Sections 1 thru 6, which requires 2% verification between calculations and testing. (No Tire Deflection) Compliance to ISO 14397-1 (2007) Sections 1 thru 5.

NOTE: Machine and bucket availability varies by region. Consult your local dealer for availability.

Bucket Type		General Purpose — Hook On						High Lift Delta
Bucket Part Number		348-0242	348-0242	348-0242	348-0243	348-0243	348-0243	
Edge Type		Bolt-on Cutting Edges	Teeth & Segments	Tips	Bolt-on Cutting Edges	Teeth & Segments	Tips	
Capacity — rated	m ³	3.10	3.10	2.90	3.30	3.30	3.10	—
	yd ³	4.05	4.05	3.79	4.32	4.32	4.05	—
Capacity — 110%	m ³	3.41	3.41	3.19	3.63	3.63	3.41	—
	yd ³	4.46	4.46	4.17	4.75	4.75	4.46	—
Width	mm	2927	2994	2994	2927	2994	2994	—
	ft/in	9'7"	9'9"	9'9"	9'7"	9'9"	9'9"	—
Dump clearance at maximum lift and 45° discharge	mm	3053	2935	2935	3015	2896	2896	289
	ft/in	10'0"	9'7"	9'7"	9'10"	9'6"	9'6"	11"
Reach at maximum lift and 45° discharge	mm	1408	1519	1519	1437	1547	1547	101
	ft/in	4'7"	4'11"	4'11"	4'8"	5'0"	5'0"	3"
Reach at level lift arm and bucket level	mm	2846	3007	3007	2895	3056	3056	277
	ft/in	9'4"	9'10"	9'10"	9'5"	10'0"	10'0"	10"
Digging depth	mm	88	88	58	88	88	58	6
	in	3.5	3.5	2.3	3.5	3.5	2.3	0
Overall length	mm	8585	8757	8757	8634	8806	8806	372
	ft/in	28'2"	28'9"	28'9"	28'4"	28'11"	28'11"	1'2"
Overall height with bucket at maximum lift	mm	5775	5775	5775	5821	5821	5821	288
	ft/in	19'0"	19'0"	19'0"	19'2"	19'2"	19'2"	11"
Loader clearance circle with bucket at carry position	mm	13 887	14 060	14 060	13 917	14 090	14 090	308
	ft/in	45'7"	46'2"	46'2"	45'8"	46'3"	46'3"	1'0"
Static tipping load, straight (With Tire Deflection)*	kg	13 202	13 063	13 399	13 105	12 965	13 300	-631
	lb	29,097	28,791	29,531	28,885	28,576	29,313	-1391
Static tipping load, straight (No Tire Deflection)*	kg	13 931	13 791	14 138	13 836	13 695	14 041	-722
	lb	30,704	30,395	31,161	30,496	30,185	30,948	-1592
Static tipping load, articulated (With Tire Deflection)*	kg	11 257	11 118	11 434	11 166	11 026	11 341	-612
	lb	24,812	24,505	25,202	24,611	24,303	24,997	-1349
Static tipping load, articulated (No Tire Deflection)*	kg	12 008	11 868	12 195	11 919	11 778	12 104	-695
	lb	26,466	26,157	26,879	26,270	25,959	26,678	-1532
Breakout force	kN	187	186	203	180	179	194	-2
	lbf	42,129	41,894	45,642	40,541	40,305	43,801	-4
Operating weight*	kg	20 627	20 735	20 578	20 673	20 781	20 624	592
	lb	45,461	45,699	45,353	45,563	45,801	45,455	1305

*Static tipping loads and operating weights shown are based on a machine configuration with Michelin 23.5R25 XHA2 L3 radial tires, full fluids, operator, cold start, roading fenders, Product Link, Manual Diff Lock/Open axles (front/rear), power train guard, secondary steering and sound suppression. (With Tire Deflection) Full compliance to ISO 14397-1 (2007) Sections 1 thru 6, which requires 2% verification between calculations and testing. (No Tire Deflection) Compliance to ISO 14397-1 (2007) Sections 1 thru 5.

NOTE: Machine and bucket availability varies by region. Consult your local dealer for availability.

Bucket Type Bucket Part Number	General Purpose — Hook On						High Lift Delta	
	354-4854	354-4854	354-4854	354-4856	354-4856	354-4856		
Edge Type	Bolt-on Cutting Edges	Teeth & Segments	Tips	Bolt-on Cutting Edges	Teeth & Segments	Tips		
Capacity — rated	m ³ yd ³	3.40 4.45	3.40 4.45	3.20 4.19	3.60 4.71	3.60 4.71	3.40 4.45	— —
Capacity — 110%	m ³ yd ³	3.74 4.89	3.74 4.89	3.52 4.60	3.96 5.18	3.96 5.18	3.74 4.89	— —
Width	mm ft/in	2927 9'7"	2994 9'9"	2994 9'9"	2927 9'7"	2994 9'9"	2994 9'9"	— —
Dump clearance at maximum lift and 45° discharge	mm ft/in	2996 9'9"	2877 9'5"	2877 9'5"	2970 9'8"	2850 9'4"	2850 9'4"	289 11"
Reach at maximum lift and 45° discharge	mm ft/in	1451 4'9"	1561 5'1"	1561 5'1"	1473 4'10"	1582 5'2"	1582 5'2"	101 3"
Reach at level lift arm and bucket level	mm ft/in	2919 9'6"	3080 10'1"	3080 10'1"	2954 9'8"	3115 10'2"	3115 10'2"	277 10"
Digging depth	mm in	88 3.5	88 3.5	58 2.3	88 3.5	88 3.5	58 2.3	6 0
Overall length	mm ft/in	8658 28'5"	8830 29'0"	8830 29'0"	8693 28'7"	8865 29'2"	8865 29'2"	372 1'2"
Overall height with bucket at maximum lift	mm ft/in	5847 19'3"	5847 19'3"	5847 19'3"	5881 19'4"	5881 19'4"	5881 19'4"	288 11"
Loader clearance circle with bucket at carry position	mm ft/in	13 932 45'9"	14 105 46'4"	14 105 46'4"	13 953 45'10"	14 127 46'5"	14 127 46'5"	308 1'0"
Static tipping load, straight (With Tire Deflection)*	kg lb	13 061 28,786	12 920 28,477	13 254 29,212	12 991 28,632	12 850 28,321	13 182 29,054	-631 -1391
Static tipping load, straight (No Tire Deflection)*	kg lb	13 793 30,399	13 651 30,087	13 996 30,848	13 724 30,248	13 582 29,935	13 926 30,693	-722 -1592
Static tipping load, articulated (With Tire Deflection)*	kg lb	11 124 24,518	10 984 24,208	11 298 24,901	11 058 24,373	10 917 24,062	11 231 24,753	-612 -1349
Static tipping load, articulated (No Tire Deflection)*	kg lb	11 877 26,178	11 736 25,866	12 061 26,584	11 813 26,036	11 671 25,722	11 996 26,439	-695 -1532
Breakout force	kN lbf	177 39,800	176 39,565	191 42,946	172 38,763	171 38,528	185 41,754	-2 -4
Operating weight*	kg lb	20 697 45,615	20 805 45,853	20 648 45,507	20 731 45,690	20 839 45,928	20 682 45,582	592 1305

*Static tipping loads and operating weights shown are based on a machine configuration with Michelin 23.5R25 XHA2 L3 radial tires, full fluids, operator, cold start, roading fenders, Product Link, Manual Diff Lock/Open axles (front/rear), power train guard, secondary steering and sound suppression. (With Tire Deflection) Full compliance to ISO 14397-1 (2007) Sections 1 thru 6, which requires 2% verification between calculations and testing. (No Tire Deflection) Compliance to ISO 14397-1 (2007) Sections 1 thru 5.

NOTE: Machine and bucket availability varies by region. Consult your local dealer for availability.

Bucket Type Bucket Part Number	General Purpose — Hook On			Material Handling — Hook On			High Lift Delta	
	376-7801	376-7801	376-7801	354-4858	354-4858	354-4858		
Edge Type	Bolt-on Cutting Edges	Teeth & Segments	Tips	Bolt-on Cutting Edges	Teeth & Segments	Tips		
Capacity — rated	m ³ yd ³	3.80 4.97	3.80 4.97	3.60 4.71	2.70 3.53	2.70 3.53	2.50 3.27	— —
Capacity — 110%	m ³ yd ³	4.18 5.47	4.18 5.47	3.96 5.18	2.97 3.88	2.97 3.88	2.75 3.60	— —
Width	mm ft/in	2927 9'7"	2994 9'9"	2994 9'9"	2927 9'7"	2994 9'9"	2994 9'9"	— —
Dump clearance at maximum lift and 45° discharge	mm ft/in	2935 9'7"	2815 9'2"	2815 9'2"	3070 10'0"	2944 9'7"	2944 9'7"	289 11"
Reach at maximum lift and 45° discharge	mm ft/in	1502 4'11"	1611 5'3"	1611 5'3"	1248 4'1"	1350 4'5"	1350 4'5"	101 3"
Reach at level lift arm and bucket level	mm ft/in	3000 9'10"	3161 10'4"	3161 10'4"	2739 8'11"	2900 9'6"	2900 9'6"	277 10"
Digging depth	mm in	88 3.5	88 3.5	58 2.3	88 3.5	88 3.5	58 2.3	6 0
Overall length	mm ft/in	8739 28'9"	8911 29'3"	8911 29'3"	8478 27'10"	8650 28'5"	8650 28'5"	372 1'2"
Overall height with bucket at maximum lift	mm ft/in	5928 19'6"	5928 19'6"	5928 19'6"	5634 18'6"	5634 18'6"	5634 18'6"	288 11"
Loader clearance circle with bucket at carry position	mm ft/in	13 982 45'11"	14 157 46'6"	14 157 46'6"	13 822 45'5"	13 994 45'11"	13 994 45'11"	308 1'0"
Static tipping load, straight (With Tire Deflection)*	kg lb	12 899 28,429	12 757 28,117	13 088 28,847	13 293 29,299	13 158 29,000	13 484 29,719	-631 -1391
Static tipping load, straight (No Tire Deflection)*	kg lb	13 634 30,049	13 490 29,734	13 834 30,490	14 001 30,859	13 864 30,557	14 200 31,298	-722 -1592
Static tipping load, articulated (With Tire Deflection)*	kg lb	10 971 24,181	10 829 23,869	11 142 24,558	11 355 25,028	11 219 24,728	11 527 25,407	-612 -1349
Static tipping load, articulated (No Tire Deflection)*	kg lb	11 728 25,849	11 585 25,533	11 909 26,248	12 085 26,636	11 948 26,334	12 265 27,033	-695 -1532
Breakout force	kN lbf	166 37,471	165 37,236	179 40,274	204 46,011	203 45,776	223 50,188	-2 -4
Operating weight*	kg lb	20 776 45,789	20 884 46,027	20 727 45,681	20 516 45,217	20 624 45,455	20 467 45,109	592 1305

*Static tipping loads and operating weights shown are based on a machine configuration with Michelin 23.5R25 XHA2 L3 radial tires, full fluids, operator, cold start, roading fenders, Product Link, Manual Diff Lock/Open axles (front/rear), power train guard, secondary steering and sound suppression. (With Tire Deflection) Full compliance to ISO 14397-1 (2007) Sections 1 thru 6, which requires 2% verification between calculations and testing. (No Tire Deflection) Compliance to ISO 14397-1 (2007) Sections 1 thru 5.

NOTE: Machine and bucket availability varies by region. Consult your local dealer for availability.

Bucket Type	Material Handling — Hook On							High Lift Delta
	Bucket Part Number	354-4860	354-4860	354-4860	354-4862	354-4862	354-4862	
Edge Type		Bolt-on Cutting Edges	Teeth & Segments	Tips	Bolt-on Cutting Edges	Teeth & Segments	Tips	
Capacity — rated	m ³	2.90	2.90	2.70	3.10	3.10	2.90	—
	yd ³	3.79	3.79	3.53	4.05	4.05	3.79	—
Capacity — 110%	m ³	3.19	3.19	2.97	3.41	3.41	3.19	—
	yd ³	4.17	4.17	3.88	4.46	4.46	4.17	—
Width	mm	2927	2994	2994	2927	2994	2994	—
	ft/in	9'7"	9'9"	9'9"	9'7"	9'9"	9'9"	—
Dump clearance at maximum lift and 45° discharge	mm	3027	2902	2902	2996	2870	2870	289
	ft/in	9'11"	9'6"	9'6"	9'9"	9'5"	9'5"	11"
Reach at maximum lift and 45° discharge	mm	1290	1393	1393	1322	1424	1424	101
	ft/in	4'2"	4'6"	4'6"	4'4"	4'8"	4'8"	3"
Reach at level lift arm and bucket level	mm	2799	2960	2960	2844	3005	3005	277
	ft/in	9'2"	9'8"	9'8"	9'3"	9'10"	9'10"	10"
Digging depth	mm	88	88	58	88	88	58	6
	in	3.5	3.5	2.3	3.5	3.5	2.3	0
Overall length	mm	8538	8710	8710	8583	8755	8755	372
	ft/in	28'11"	28'7"	28'7"	28'2"	28'9"	28'9"	1'2"
Overall height with bucket at maximum lift	mm	5697	5697	5697	5734	5734	5734	288
	ft/in	18'9"	18'9"	18'9"	18'10"	18'10"	18'10"	11"
Loader clearance circle with bucket at carry position	mm	13 858	14 030	14 030	13 886	14 058	14 058	308
	ft/in	45'6"	46'1"	46'1"	45'7"	46'2"	46'2"	1'0"
Static tipping load, straight (With Tire Deflection)*	kg	13 181	13 044	13 367	13 084	12 946	13 269	-631
	lb	29,052	28,750	29,462	28,837	28,534	29,245	-1391
Static tipping load, straight (No Tire Deflection)*	kg	13 891	13 753	14 086	13 795	13 656	13 989	-722
	lb	30,617	30,313	31,046	30,405	30,100	30,833	-1592
Static tipping load, articulated (With Tire Deflection)*	kg	11 250	11 113	11 418	11 158	11 020	11 325	-612
	lb	24,795	24,493	25,165	24,593	24,289	24,961	-1349
Static tipping load, articulated (No Tire Deflection)*	kg	11 982	11 844	12 158	11 891	11 753	12 067	-695
	lb	26,408	26,104	26,797	26,209	25,903	26,596	-1532
Breakout force	kN	194	193	211	187	186	203	-2
	lbf	43,760	43,525	47,543	42,185	41,950	45,708	-4
Operating weight*	kg	20 568	20 676	20 519	20 617	20 725	20 568	592
	lb	45,331	45,569	45,223	45,439	45,677	45,331	1305

*Static tipping loads and operating weights shown are based on a machine configuration with Michelin 23.5R25 XHA2 L3 radial tires, full fluids, operator, cold start, roading fenders, Product Link, Manual Diff Lock/Open axles (front/rear), power train guard, secondary steering and sound suppression. (With Tire Deflection) Full compliance to ISO 14397-1 (2007) Sections 1 thru 6, which requires 2% verification between calculations and testing. (No Tire Deflection) Compliance to ISO 14397-1 (2007) Sections 1 thru 5.

NOTE: Machine and bucket availability varies by region. Consult your local dealer for availability.

Bucket Type	Material Handling — Hook On							High Lift Delta
	Bucket Part Number	354-4864	354-4864	354-4864	354-4866	354-4866	354-4866	
Edge Type		Bolt-on Cutting Edges	Teeth & Segments	Tips	Bolt-on Cutting Edges	Teeth & Segments	Tips	
Capacity — rated	m ³	3.30	3.30	3.10	3.40	3.40	3.20	—
	yd ³	4.32	4.32	4.05	4.45	4.45	4.19	—
Capacity — 110%	m ³	3.63	3.63	3.41	3.74	3.74	3.52	—
	yd ³	4.75	4.75	4.46	4.89	4.89	4.60	—
Width	mm	2927	2994	2994	2927	2994	2994	—
	ft/in	9'7"	9'9"	9'9"	9'7"	9'9"	9'9"	—
Dump clearance at maximum lift and 45° discharge	mm	2964	2838	2838	2936	2810	2810	289
	ft/in	9'8"	9'3"	9'3"	9'7"	9'2"	9'2"	11"
Reach at maximum lift and 45° discharge	mm	1354	1456	1456	1382	1485	1485	101
	ft/in	4'5"	4'9"	4'9"	4'6"	4'10"	4'10"	3"
Reach at level lift arm and bucket level	mm	2889	3050	3050	2929	3090	3090	277
	ft/in	9'5"	10'0"	10'0"	9'7"	10'1"	10'1"	10"
Digging depth	mm	88	88	58	88	88	58	6
	in	3.5	3.5	2.3	3.5	3.5	2.3	0
Overall length	mm	8628	8800	8800	8668	8840	8840	372
	ft/in	28'4"	28'11"	28'11"	28'6"	29'1"	29'1"	1'2"
Overall height with bucket at maximum lift	mm	5778	5778	5778	5817	5817	5817	288
	ft/in	19'0"	19'0"	19'0"	19'1"	19'1"	19'1"	11"
Loader clearance circle with bucket at carry position	mm	13 913	14 086	14 086	13 938	14 112	14 112	308
	ft/in	45'8"	46'3"	46'3"	45'9"	46'4"	46'4"	1'0"
Static tipping load, straight (With Tire Deflection)*	kg	12 992	12 853	13 179	12 916	12 777	13 099	-631
	lb	28,634	28,329	29,048	28,467	28,160	28,871	-1391
Static tipping load, straight (No Tire Deflection)*	kg	13 704	13 565	13 902	13 630	13 490	13 823	-722
	lb	30,205	29,897	30,640	30,042	29,732	30,466	-1592
Static tipping load, articulated (With Tire Deflection)*	kg	11 071	10 933	11 241	11 000	10 860	11 165	-612
	lb	24,402	24,097	24,775	24,244	23,937	24,609	-1349
Static tipping load, articulated (No Tire Deflection)*	kg	11 806	11 667	11 985	11 736	11 596	11 911	-695
	lb	26,021	25,714	26,415	25,867	25,558	26,251	-1532
Breakout force	kN	181	180	195	175	174	189	-2
	lbf	40,717	40,482	44,006	39,488	39,253	42,588	-4
Operating weight*	kg	20 661	20 769	20 612	20 699	20 807	20 650	592
	lb	45,536	45,774	45,428	45,620	45,858	45,512	1305

*Static tipping loads and operating weights shown are based on a machine configuration with Michelin 23.5R25 XHA2 L3 radial tires, full fluids, operator, cold start, roading fenders, Product Link, Manual Diff Lock/Open axles (front/rear), power train guard, secondary steering and sound suppression. (With Tire Deflection) Full compliance to ISO 14397-1 (2007) Sections 1 thru 6, which requires 2% verification between calculations and testing. (No Tire Deflection) Compliance to ISO 14397-1 (2007) Sections 1 thru 5.

NOTE: Machine and bucket availability varies by region. Consult your local dealer for availability.

Bucket Type	Material Handling — Hook On							High Lift Delta
	Bucket Part Number	367-5735	367-5735	367-5735	354-4868	354-4868	354-4868	
Edge Type		Bolt-on Cutting Edges	Teeth & Segments	Tips	Bolt-on Cutting Edges	Teeth & Segments	Tips	
Capacity — rated	m ³	3.60	3.60	3.40	3.80	3.80	3.60	—
	yd ³	4.71	4.71	4.45	4.97	4.97	4.71	—
Capacity — 110%	m ³	3.96	3.96	3.74	4.18	4.18	3.96	—
	yd ³	5.18	5.18	4.89	5.47	5.47	5.18	—
Width	mm	2927	2994	2994	2927	2994	2994	—
	ft/in	9'7"	9'9"	9'9"	9'7"	9'9"	9'9"	—
Dump clearance at maximum lift and 45° discharge	mm	2904	2778	2778	2868	2742	2742	289
	ft/in	9'6"	9'1"	9'1"	9'4"	8'11"	8'11"	11"
Reach at maximum lift and 45° discharge	mm	1414	1516	1516	1450	1552	1552	101
	ft/in	4'7"	4'11"	4'11"	4'9"	5'1"	5'1"	3"
Reach at level lift arm and bucket level	mm	2974	3135	3135	3025	3186	3186	277
	ft/in	9'9"	10'3"	10'3"	9'11"	10'5"	10'5"	10"
Digging depth	mm	88	88	58	88	88	58	6
	in	3.5	3.5	2.3	3.5	3.5	2.3	0
Overall length	mm	8713	8885	8885	8764	8936	8936	372
	ft/in	28'8"	29'2"	29'2"	28'10"	29'4"	29'4"	1'2"
Overall height with bucket at maximum lift	mm	5860	5860	5860	5913	5913	5913	288
	ft/in	19'3"	19'3"	19'3"	19'5"	19'5"	19'5"	11"
Loader clearance circle with bucket at carry position	mm	13 966	14 140	14 140	13 998	14 173	14 173	308
	ft/in	45'10"	46'5"	46'5"	46'0"	46'6"	46'6"	1'0"
Static tipping load, straight (With Tire Deflection)*	kg	12 828	12 688	13 011	12 723	12 582	12 905	-631
	lb	28,273	27,965	28,676	28,042	27,731	28,443	-1391
Static tipping load, straight (No Tire Deflection)*	kg	13 544	13 402	13 736	13 440	13 298	13 632	-722
	lb	29,851	29,540	30,274	29,623	29,310	30,044	-1592
Static tipping load, articulated (With Tire Deflection)*	kg	10 917	10 777	11 082	10 818	10 677	10 982	-612
	lb	24,062	23,754	24,426	23,843	23,533	24,206	-1349
Static tipping load, articulated (No Tire Deflection)*	kg	11 655	11 514	11 829	11 557	11 415	11 731	-695
	lb	25,688	25,377	26,072	25,473	25,160	25,855	-1532
Breakout force	kN	169	168	182	163	162	175	-2
	lbf	38,188	37,953	41,095	36,790	36,555	39,498	-4
Operating weight*	kg	20 739	20 847	20 690	20 793	20 901	20 744	592
	lb	45,708	45,946	45,600	45,827	46,065	45,719	1305

*Static tipping loads and operating weights shown are based on a machine configuration with Michelin 23.5R25 XHA2 L3 radial tires, full fluids, operator, cold start, roading fenders, Product Link, Manual Diff Lock/Open axles (front/rear), power train guard, secondary steering and sound suppression. (With Tire Deflection) Full compliance to ISO 14397-1 (2007) Sections 1 thru 6, which requires 2% verification between calculations and testing. (No Tire Deflection) Compliance to ISO 14397-1 (2007) Sections 1 thru 5.

NOTE: Machine and bucket availability varies by region. Consult your local dealer for availability.

Bucket Type Bucket Part Number		General Purpose — Pin On		
		395-2119	416-6342	416-6343
Edge Type		Bolt-on Cutting Edges	Bolt-on Cutting Edges	Bolt-on Cutting Edges
Capacity — rated	m ³	3.80	4.00	4.20
	yd ³	4.97	5.23	5.49
Capacity — 110%	m ³	4.18	4.40	4.62
	yd ³	5.47	5.75	6.04
Width	mm	2994	2994	2994
	ft/in	9'9"	9'9"	9'9"
Dump clearance at maximum lift and 45° discharge	mm	2992	2962	2929
	ft/in	9'9"	9'8"	9'7"
Reach at maximum lift and 45° discharge	mm	1440	1466	1496
	ft/in	4'8"	4'9"	4'10"
Reach at level lift arm and bucket level	mm	2916	2956	3001
	ft/in	9'6"	9'8"	9'10"
Digging depth	mm	88	88	88
	in	3.5	3.5	3.5
Overall length	mm	8694	8734	8779
	ft/in	28'7"	28'8"	28'10"
Overall height with bucket at maximum lift	mm	5897	5937	5984
	ft/in	19'5"	19'6"	19'8"
Loader clearance circle with bucket at carry position	mm	13 997	14 021	14 049
	ft/in	46'0"	46'0"	46'2"
Static tipping load, straight (With Tire Deflection)*	kg	14 514	14 412	14 314
	lb	31,989	31,764	31,548
Static tipping load, straight (No Tire Deflection)*	kg	15 338	15 237	15 141
	lb	33,805	33,584	33,372
Static tipping load, articulated (With Tire Deflection)*	kg	12 359	12 262	12 170
	lb	27,239	27,027	26,823
Static tipping load, articulated (No Tire Deflection)*	kg	13 211	13 116	13 026
	lb	29,117	28,908	28,709
Breakout force	kN	176	171	165
	lbf	39,704	38,496	37,233
Operating weight*	kg	20 984	21 038	21 084
	lb	46,249	46,368	46,469

*Static tipping loads and operating weights shown are based on a machine configuration with Michelin 23.5R25 XHA2 L3 radial tires, full fluids, operator, cold start, roading fenders, Product Link, Manual Diff Lock/Open axles (front/rear), power train guard, secondary steering and sound suppression. (With Tire Deflection) Full compliance to ISO 14397-1 (2007) Sections 1 thru 6, which requires 2% verification between calculations and testing. (No Tire Deflection) Compliance to ISO 14397-1 (2007) Sections 1 thru 5.

NOTE: Machine and bucket availability varies by region. Consult your local dealer for availability.

Linkage Bucket Type	Standard Linkage			Standard Linkage			High Lift Linkage Change**	
	General Purpose – Pin On							
Edge Type	Bolt-on Cutting Edges	Teeth & Segments	Tips	Bolt-on Cutting Edges	Teeth & Segments	Tips		
Capacity – rated	m ³ yd ³	3.80 5.00	3.80 5.00	3.60 4.75	4.00 5.25	4.00 5.25	3.80 5.00	– –
Capacity – rated at 110% fill factor	m ³ yd ³	4.18 5.47	4.18 5.47	3.96 5.18	4.40 5.75	4.40 5.75	4.18 5.47	– –
Width	mm ft/in	3220 10'6"	3271 10'8"	3271 10'8"	3220 10'6"	3271 10'8"	3271 10'8"	– –
Dump clearance at maximum lift and 45° discharge	mm ft/in	3067 10'0"	2915 9'6"	2915 9'6"	3058 10'0"	2905 9'6"	2905 9'6"	558 1'10"
Reach at maximum lift and 45° discharge	mm ft/in	1292 4'2"	1432 4'8"	1432 4'8"	1299 4'3"	1438 4'8"	1438 4'8"	–24 –0.9"
Reach at level lift arm and bucket level	mm ft/in	2704 8'10"	2908 9'6"	2908 9'6"	2715 8'10"	2920 9'6"	2920 9'6"	405 1'4"
Digging depth	mm in	124 4.9	124 4.9	94 3.7	124 4.9	124 4.9	94 3.7	–25 –1
Shipping length (With Bucket)	mm ft/in	8651 28'5"	8876 29'2"	8876 29'2"	8663 28'6"	8888 29'2"	8888 29'2"	820 2'8"
Overall height with bucket at maximum lift	mm ft/in	5788 19'0"	5788 19'0"	5788 19'0"	5902 19'5"	5902 19'5"	5902 19'5"	558 1'10"
Loader clearance circle with bucket at carry position	mm ft/in	14 973 49'2"	15 142 49'9"	15 142 49'9"	14 979 49'2"	15 148 49'9"	15 148 49'9"	479 1'7"
Static tipping load, straight (With Tire Deflection)*	kg lb	16 874 37,192	16 693 36,791	16 891 37,229	16 856 37,152	16 674 36,750	16 908 37,266	22 48
Static tipping load, straight (No Tire Deflection)*	kg lb	18 045 39,772	17 860 39,364	18 048 39,777	18 037 39,754	17 851 39,344	18 088 39,867	–75 –165
Static tipping load, articulated (With Tire Deflection)*	kg lb	14 876 32,788	14 693 32,384	14 883 32,804	14 855 32,741	14 671 32,335	14 890 32,818	–163 –359
Static tipping load, articulated (No Tire Deflection)*	kg lb	16 029 35,329	15 844 34,921	16 023 35,315	16 017 35,303	15 831 34,893	16 052 35,379	–225 –496
Breakout force	kN lbf	187 42,151	185 41,781	199 44,901	185 41,695	183 41,326	197 44,390	–17 –37
Operating weight*	kg lb	23 112 50,938	23 250 51,242	23 087 50,883	23 164 51,053	23 302 51,357	23 139 50,997	1612 3553

*Static tipping loads and operating weights shown are based on a machine configuration with Michelin 26.5R25 XHA2 L3 radial tires, full fluids, operator, standard counterweight, cold start, roading fenders, Product Link, Manual Diff Lock/Open axles (front/rear), power train guard, secondary steering and sound suppression.

**Maximum values.

(With Tire Deflection) Full compliance to ISO 14397-1 (2007) Sections 1 thru 6, which requires 2% verification between calculations and testing.
(No Tire Deflection) Compliance to ISO 14397-1 (2007) Sections 1 thru 5.

NOTE: Machine and bucket availability varies by region. Consult your local dealer for availability.

Linkage Bucket Type	Standard Linkage			Standard Linkage			High Lift Linkage Change**	
	General Purpose – Pin On			General Purpose – Fusion QC				
Edge Type	Bolt-on Cutting Edges	Teeth & Segments	Tips	Bolt-on Cutting Edges	Teeth & Segments	Tips		
Capacity – rated	m ³	4.20	4.20	4.00	3.80	3.80	3.60	–
	yd ³	5.50	5.50	5.25	5.00	5.00	4.75	–
Capacity – rated at 110% fill factor	m ³	4.62	4.62	4.40	4.18	4.18	3.96	–
	yd ³	6.04	6.04	5.75	5.47	5.47	5.18	–
Width	mm	3220	3271	3271	3220	3271	3271	–
	ft/in	10'6"	10'8"	10'8"	10'6"	10'8"	10'8"	–
Dump clearance at maximum lift and 45° discharge	mm	2991	2837	2837	3038	2886	2886	558
	ft/in	9'9"	9'3"	9'3"	9'11"	9'5"	9'5"	1'10"
Reach at maximum lift and 45° discharge	mm	1353	1490	1490	1327	1466	1466	–25
	ft/in	4'5"	4'10"	4'10"	4'4"	4'9"	4'9"	–1"
Reach at level lift arm and bucket level	mm	2803	3008	3008	2748	2953	2953	404
	ft/in	9'2"	9'10"	9'10"	9'0"	9'8"	9'8"	1'4"
Digging depth	mm	124	124	94	124	124	94	–25
	in	4.9	4.9	3.7	4.9	4.9	3.7	–1
Shipping length (With Bucket)	mm	8750	8975	8975	8696	8921	8921	820
	ft/in	28'9"	29'6"	29'6"	28'7"	29'4"	29'4"	2'8"
Overall height with bucket at maximum lift	mm	5902	5902	5902	5803	5803	5803	558
	ft/in	19'5"	19'5"	19'5"	19'1"	19'1"	19'1"	1'10"
Loader clearance circle with bucket at carry position	mm	15 022	15 193	15 193	14 988	15 160	15 160	487
	ft/in	49'4"	49'11"	49'11"	49'3"	49'9"	49'9"	1'7"
Static tipping load, straight (With Tire Deflection)*	kg	16 656	16 473	16 714	16 299	16 118	16 461	51
	lb	36,711	36,307	36,839	35,923	35,524	36,281	112
Static tipping load, straight (No Tire Deflection)*	kg	17 828	17 641	17 886	17 442	17 258	17 617	–44
	lb	39,293	38,881	39,421	38,444	38,038	38,828	–97
Static tipping load, articulated (With Tire Deflection)*	kg	14 668	14 483	14 709	14 323	14 140	14 470	–137
	lb	32,329	31,921	32,420	31,568	31,166	31,892	–302
Static tipping load, articulated (No Tire Deflection)*	kg	15 822	15 636	15 864	15 453	15 269	15 611	–196
	lb	34,873	34,461	34,964	34,059	33,653	34,408	–432
Breakout force	kN	173	171	184	180	179	192	–16
	lbf	38,984	38,618	41,343	40,632	40,264	43,192	–35
Operating weight*	kg	23 220	23 358	23 195	23 529	23 667	23 504	1612
	lb	51,176	51,480	51,121	51,857	52,161	51,802	3553

*Static tipping loads and operating weights shown are based on a machine configuration with Michelin 26.5R25 XHA2 L3 radial tires, full fluids, operator, standard counterweight, cold start, roading fenders, Product Link, Manual Diff Lock/Open axles (front/rear), power train guard, secondary steering and sound suppression.

**Maximum values.

(With Tire Deflection) Full compliance to ISO 14397-1 (2007) Sections 1 thru 6, which requires 2% verification between calculations and testing.
(No Tire Deflection) Compliance to ISO 14397-1 (2007) Sections 1 thru 5.

NOTE: Machine and bucket availability varies by region. Consult your local dealer for availability.

Linkage Bucket Type	Standard Linkage			Standard Linkage			High Lift Linkage Change**	
	General Purpose – Fusion QC			Material Handling – Pin On				
Edge Type	Bolt-on Cutting Edges	Teeth & Segments	Tips	Bolt-on Cutting Edges	Teeth & Segments	Tips		
Capacity – rated	m ³ yd ³	4.20 5.50	4.20 5.50	4.00 5.25	4.20 5.50	4.20 5.50	4.04 5.30	– –
Capacity – rated at 110% fill factor	m ³ yd ³	4.62 6.04	4.62 6.04	4.40 5.75	4.62 6.04	4.62 6.04	4.44 5.81	– –
Width	mm ft/in	3220 10'6"	3271 10'8"	3271 10'8"	3220 10'6"	3271 10'8"	3271 10'8"	– –
Dump clearance at maximum lift and 45° discharge	mm ft/in	2960 9'8"	2806 9'2"	2806 9'2"	2949 9'8"	2787 9'1"	2787 9'1"	559 1'10"
Reach at maximum lift and 45° discharge	mm ft/in	1398 4'7"	1536 5'0"	1536 5'0"	1245 4'1"	1372 4'6"	1372 4'6"	–24 –0.9"
Reach at level lift arm and bucket level	mm ft/in	2858 9'4"	3062 10'0"	3062 10'0"	2774 9'1"	2978 9'9"	2978 9'9"	405 1'4"
Digging depth	mm in	116 4.5	116 4.5	86 3.4	124 4.9	124 4.9	94 3.7	–25 –1
Shipping length (With Bucket)	mm ft/in	8798 28'11"	9024 29'8"	9024 29'8"	8721 28'8"	8946 29'5"	8946 29'5"	822 2'8"
Overall height with bucket at maximum lift	mm ft/in	5960 19'7"	5960 19'7"	5960 19'7"	5901 19'5"	5901 19'5"	5901 19'5"	558 1'10"
Loader clearance circle with bucket at carry position	mm ft/in	15 038 49'5"	15 212 49'11"	15 212 49'11"	15 008 49'3"	15 178 49'10"	15 178 49'10"	493 1'7"
Static tipping load, straight (With Tire Deflection)*	kg lb	16 031 35,334	15 850 34,933	16 186 35,675	16 580 36,544	16 398 36,143	16 729 36,871	95 209
Static tipping load, straight (No Tire Deflection)*	kg lb	17 173 37,850	16 988 37,442	17 339 38,216	17 731 39,080	17 546 38,672	17 890 39,430	34 75
Static tipping load, articulated (With Tire Deflection)*	kg lb	14 075 31,022	13 892 30,618	14 216 31,332	14 605 32,190	14 421 31,786	14 738 32,483	–106 –234
Static tipping load, articulated (No Tire Deflection)*	kg lb	15 204 33,510	15 019 33,102	15 355 33,843	15 740 34,691	15 555 34,283	15 883 35,006	–158 –348
Breakout force	kN lbf	166 37,382	164 37,023	176 39,561	177 39,834	175 39,468	188 42,297	–15 –33
Operating weight*	kg lb	23 592 51,997	23 730 52,301	23 567 51,941	23 217 51,170	23 355 51,474	23 192 51,114	1612 3553

*Static tipping loads and operating weights shown are based on a machine configuration with Michelin 26.5R25 XHA2 L3 radial tires, full fluids, operator, standard counterweight, cold start, roading fenders, Product Link, Manual Diff Lock/Open axles (front/rear), power train guard, secondary steering and sound suppression.

**Maximum values.

(With Tire Deflection) Full compliance to ISO 14397-1 (2007) Sections 1 thru 6, which requires 2% verification between calculations and testing. (No Tire Deflection) Compliance to ISO 14397-1 (2007) Sections 1 thru 5.

NOTE: Machine and bucket availability varies by region. Consult your local dealer for availability.

Wheel Loaders Integrated Toolcarriers

Performance Data ● 966M Aggregate Package

Package	Aggregate Handler			Aggregate Handler		Aggregate Handler	
Bucket Type	General Purpose – Pin On			General Purpose – Fusion QC		Material Handling – Pin On	
Edge Type	Bolt-on Cutting Edges	Bolt-on Cutting Edges	Bolt-on Cutting Edges	Bolt-on Cutting Edges	Bolt-on Cutting Edges	Bolt-on Cutting Edges	
Capacity – rated	m ³ yd ³	3.80 5.00	4.00 5.25	4.20 5.50	3.80 5.00	4.20 5.50	4.20 5.50
Capacity – rated at 110% fill factor	m ³ yd ³	4.18 5.47	4.40 5.75	4.62 6.04	4.18 5.47	4.62 6.04	4.62 6.04
Width	mm ft/in	3220 10'6"	3220 10'6"	3220 10'6"	3220 10'6"	3220 10'6"	3220 10'6"
Dump clearance at maximum lift and 45° discharge	mm ft/in	3067 10'0"	3058 10'0"	2991 9'9"	3038 9'11"	2960 9'8"	2967 9'8"
Reach at maximum lift and 45° discharge	mm ft/in	1292 4'2"	1299 4'3"	1353 4'5"	1327 4'4"	1398 4'7"	1228 4'0"
Reach at level lift arm and bucket level	mm ft/in	2704 8'10"	2715 8'10"	2803 9'2"	2748 9'0"	2858 9'4"	2749 9'0"
Digging depth	mm in	124 4.9	124 4.9	124 4.9	124 4.9	116 4.5	124 4.9
Shipping length (With Bucket)	mm ft/in	8657 28'5"	8669 28'6"	8756 28'9"	8702 28'7"	8804 28'11"	8702 28'7"
Overall height with bucket at maximum lift	mm ft/in	5788 19'0"	5902 19'5"	5902 19'5"	5803 19'1"	5960 19'7"	5874 19'4"
Loader clearance circle with bucket at carry position	mm ft/in	14 973 49'2"	14 979 49'2"	15 022 49'4"	14 988 49'3"	15 038 49'5"	14 995 49'3"
Static tipping load, straight (With Tire Deflection)*	kg lb	18 475 40,719	18 459 40,684	18 247 40,217	17 880 39,408	17 595 38,780	18 199 40,111
Static tipping load, straight (No Tire Deflection)*	kg lb	19 797 43,634	19 792 43,623	19 570 43,134	19 171 42,254	18 884 41,622	19 496 42,969
Static tipping load, articulated (With Tire Deflection)*	kg lb	16 232 35,777	16 212 35,732	16 015 35,299	15 662 34,519	15 399 33,940	15 982 35,225
Static tipping load, articulated (No Tire Deflection)*	kg lb	17 540 38,658	17 531 38,638	17 325 38,185	16 944 37,345	16 680 36,762	17 266 38,056
Breakout force	kN lbf	187 42,151	185 41,695	173 38,984	180 40,632	166 37,382	180 40,629
Operating weight*	kg lb	23 807 52,470	23 859 52,584	23 915 52,708	24 224 53,389	24 287 53,528	23 869 52,606

*Static tipping loads and operating weights shown are based on a machine configuration with Michelin 26.5R25 XHA2 L3 radial tires, full fluids, operator, aggregate counterweight, cold start, roading fenders, Product Link, Manual Diff Lock/Open axles (front/rear), power train guard, secondary steering and sound suppression. If a rock bucket is added, those values are with Michelin 26.5R25 XLDD2 L5 tires.

(With Tire Deflection) Full compliance to ISO 14397-1 (2007) Sections 1 thru 6, which requires 2% verification between calculations and testing.
(No Tire Deflection) Compliance to ISO 14397-1 (2007) Sections 1 thru 5.

NOTE: Machine and bucket availability varies by region. Consult your local dealer for availability.

Linkage Bucket Type	Standard Linkage			Standard Linkage			High Lift Linkage Change**	
	General Purpose – Pin On							
Edge Type	Bolt-on Cutting Edges	Teeth & Segments	Tips	Bolt-on Cutting Edges	Teeth & Segments	Tips		
Capacity – rated	m ³ yd ³	4.60 6.00	4.60 6.00	4.40 5.75	4.80 6.25	4.80 6.25	4.60 6.00	– –
Capacity – rated at 110% fill factor	m ³ yd ³	5.06 6.62	5.06 6.62	4.84 6.33	5.28 6.91	5.28 6.91	5.06 6.62	– –
Width	mm ft/in	3220 10'6"	3271 10'8"	3271 10'8"	3220 10'6"	3271 10'8"	3271 10'8"	– –
Dump clearance at maximum lift and 45° discharge	mm ft/in	3187 10'5"	3033 9'11"	3033 9'11"	3154 10'4"	2999 9'10"	2999 9'10"	336 1'1"
Reach at maximum lift and 45° discharge	mm ft/in	1328 4'4"	1465 4'9"	1465 4'9"	1357 4'5"	1493 4'10"	1493 4'10"	23 0.9"
Reach at level lift arm and bucket level	mm ft/in	2969 9'8"	3174 10'4"	3174 10'4"	3014 9'10"	3219 10'6"	3219 10'6"	274 11"
Digging depth	mm in	103 4	103 4	73 2.8	103 4	103 4	73 2.8	–5 –0.2
Shipping length (With Bucket)	mm ft/in	9270 30'5"	9494 31'2"	9494 31'2"	9315 30'7"	9539 31'4"	9539 31'4"	335 1'1"
Overall height with bucket at maximum lift	mm ft/in	6195 20'4"	6195 20'4"	6195 20'4"	6031 19'10"	6031 19'10"	6031 19'10"	336 1'1"
Loader clearance circle with bucket at carry position	mm ft/in	15 192 49'11"	15 369 50'6"	15 369 50'6"	15 216 50'0"	15 394 50'7"	15 394 50'7"	323 1'0.7"
Static tipping load, straight (With Tire Deflection)*	kg lb	18 477 40,723	18 293 40,319	18 550 40,884	18 502 40,779	18 318 40,372	20 545 45,281	–1592 –3508
Static tipping load, straight (No Tire Deflection)*	kg lb	19 724 43,473	19 537 43,061	19 796 43,631	19 755 43,542	19 567 43,127	22 192 48,912	–1752 –3863
Static tipping load, articulated (With Tire Deflection)*	kg lb	16 135 35,563	15 950 35,155	16 188 35,680	16 164 35,626	15 978 35,215	17 927 39,512	–1423 –3137
Static tipping load, articulated (No Tire Deflection)*	kg lb	17 387 38,322	17 200 37,910	17 439 38,437	17 421 38,396	17 233 37,982	19 558 43,107	–1598 –3521
Breakout force	kN lbf	202 45,482	201 45,173	214 48,227	196 44,075	194 43,766	207 46,655	–6 –1368
Operating weight*	kg lb	24 969 55,030	25 106 55,334	24 943 54,974	24 897 54,871	25 034 55,175	24 871 54,816	84 186

*Static tipping loads and operating weights shown are based on a machine configuration with Michelin 26.5R25 XHA2 L3 radial tires, full fluids, operator, standard counterweight, cold start, roading fenders, Product Link, Manual Diff Lock/Open axles (front/rear), power train guard, secondary steering and sound suppression.

**Maximum values.

(With Tire Deflection) Full compliance to ISO 14397-1 (2007) Sections 1 thru 6, which requires 2% verification between calculations and testing.
(No Tire Deflection) Compliance to ISO 14397-1 (2007) Sections 1 thru 5.

NOTE: Machine and bucket availability varies by region. Consult your local dealer for availability.

Linkage Bucket Type	Standard Linkage			Standard Linkage			High Lift Linkage Change**	
	General Purpose – Pin On			General Purpose – Fusion QC				
Edge Type	Bolt-on Cutting Edges	Teeth & Segments	Tips	Bolt-on Cutting Edges	Teeth & Segments	Tips		
Capacity – rated	m ³ yd ³	5.00 6.50	5.00 6.50	4.80 6.25	4.40 5.75	4.40 5.75	4.20 5.50	– –
Capacity – rated at 110% fill factor	m ³ yd ³	5.50 7.19	5.50 7.19	5.28 6.91	4.84 6.33	4.84 6.33	4.62 6.04	– –
Width	mm ft/in	3220 10'6"	3271 10'8"	3271 10'8"	3220 10'6"	3271 10'8"	3271 10'8"	– –
Dump clearance at maximum lift and 45° discharge	mm ft/in	3137 10'3"	2982 9'9"	2982 9'9"	3200 10'6"	3047 9'11"	3047 9'11"	336 1'1"
Reach at maximum lift and 45° discharge	mm ft/in	1372 4'6"	1508 4'11"	1508 4'11"	1327 4'4"	1465 4'9"	1465 4'9"	23 0.9"
Reach at level lift arm and bucket level	mm ft/in	3037 9'11"	3242 10'7"	3242 10'7"	2958 9'8"	3163 10'4"	3163 10'4"	274 11"
Digging depth	mm in	103 4	103 4	73 2.8	103 4	103 4	73 2.8	–5 –0.2
Shipping length (With Bucket)	mm ft/in	9338 30'8"	9562 31'5"	9562 31'5"	9259 30'5"	9483 31'2"	9483 31'2"	335 1'1"
Overall height with bucket at maximum lift	mm ft/in	6284 20'8"	6284 20'8"	6284 20'8"	6205 20'5"	6205 20'5"	6205 20'5"	336 1'1"
Loader clearance circle with bucket at carry position	mm ft/in	15 229 50'0"	15 407 50'7"	15 407 50'7"	15 180 49'10"	15 359 50'5"	15 359 50'5"	324 1'0.8"
Static tipping load, straight (With Tire Deflection)*	kg lb	18 600 40,996	18 415 40,588	18 651 41,108	18 081 39,851	17 899 39,450	18 257 40,240	–1608 –3545
Static tipping load, straight (No Tire Deflection)*	kg lb	19 856 43,764	19 668 43,348	19 906 43,873	19 317 42,576	19 131 42,166	19 507 42,993	–1771 –3903
Static tipping load, articulated (With Tire Deflection)*	kg lb	16 264 35,845	16 076 35,433	16 297 35,919	15 749 34,712	15 565 34,307	15 907 35,060	–1444 –3181
Static tipping load, articulated (No Tire Deflection)*	kg lb	17 521 38,617	17 332 38,200	17 553 38,687	16 992 37,452	16 807 37,043	17 163 37,828	–1620 –3570
Breakout force	kN lbf	198 44,634	197 44,325	210 47,205	203 45,788	202 45,479	216 48,572	–6 –1378
Operating weight*	kg lb	25 010 55,120	25 147 55,424	24 984 55,065	25 327 55,819	25 464 56,123	25 301 55,763	84 186

*Static tipping loads and operating weights shown are based on a machine configuration with Michelin 26.5R25 XHA2 L3 radial tires, full fluids, operator, standard counterweight, cold start, roading fenders, Product Link, Manual Diff Lock/Open axles (front/rear), power train guard, secondary steering and sound suppression.

**Maximum values.

(With Tire Deflection) Full compliance to ISO 14397-1 (2007) Sections 1 thru 6, which requires 2% verification between calculations and testing.
(No Tire Deflection) Compliance to ISO 14397-1 (2007) Sections 1 thru 5.

NOTE: Machine and bucket availability varies by region. Consult your local dealer for availability.

Linkage Bucket Type	Standard Linkage				High Lift Linkage Change**	Extended Linkage		
	Material Handling — Pin On			General Purpose — Fusion QC				
Edge Type	Bolt-on Cutting Edges	Teeth & Segments	Tips		Bolt-on Cutting Edges	Teeth & Segments	Tips	
Capacity — rated	m ³ yd ³	4.60 6.00	4.60 6.00	4.40 5.75	— —	4.90 6.41	4.90 6.41	4.70 6.15
Capacity — rated at 110% fill factor	m ³ yd ³	5.06 6.62	5.06 6.62	4.84 6.33	— —	5.39 7.05	5.39 7.05	5.17 6.76
Width	mm ft/in	3220 10'6"	3271 10'8"	3271 10'8"	— —	3220 10'6"	3271 10'8"	3271 10'8"
Dump clearance at maximum lift and 45° discharge	mm ft/in	3120 10'2"	2957 9'8"	2957 9'8"	336 1'1"	2899 9'6"	2744 9'0"	2744 9'0"
Reach at maximum lift and 45° discharge	mm ft/in	1251 4'1"	1378 4'6"	1378 4'6"	23 0.9"	1449 4'9"	1586 5'2"	1586 5'2"
Reach at level lift arm and bucket level	mm ft/in	2979 9'9"	3184 10'5"	3184 10'5"	274 11"	2940 9'7"	3145 10'3"	3145 10'3"
Digging depth	mm in	103 4	103 4	73 2.8	-5 -0.2	115 4.5	115 4.5	85 3.3
Shipping length (With Bucket)	mm ft/in	9280 30'6"	9504 31'3"	9504 31'3"	335 1'1"	9200 30'3"	9425 31'0"	9425 31'0"
Overall height with bucket at maximum lift	mm ft/in	6162 20'3"	6162 20'3"	6162 20'3"	336 1'1"	6126 20'2"	6126 20'2"	6126 20'2"
Loader clearance circle with bucket at carry position	mm ft/in	15 197 49'11"	15 375 50'6"	15 375 50' 6"	334 1'1"	15 081 49'6"	15 255 50'1"	15 255 50'1"
Static tipping load, straight (With Tire Deflection)*	kg lb	18 412 40,580	18 229 40,177	18 468 40,704	-1598 -3521	19 411 42,781	19 225 42,372	19 590 43,177
Static tipping load, straight (No Tire Deflection)*	kg lb	19 640 43,286	19 453 42,875	19 695 43,409	-1757 -3871	20 885 46,032	20 695 45,612	21 079 46,460
Static tipping load, articulated (With Tire Deflection)*	kg lb	16 081 35,442	15 896 35,035	16 119 35,526	-1429 -3149	16 920 37,293	16 732 36,878	17 082 37,649
Static tipping load, articulated (No Tire Deflection)*	kg lb	17 313 38,159	17 127 37,749	17 351 38,242	-1601 -3528	18 387 40,526	18 197 40,106	18 562 40,912
Breakout force	kN lbf	201 45,174	199 44,865	213 47,882	-7 -1647	198 44,570	196 44,204	209 47,022
Operating weight*	kg lb	24 964 55,019	25 101 55,323	24 938 54,963	85 186	25 283 55,724	25 421 56,028	25 258 55,668

*Static tipping loads and operating weights shown are based on a machine configuration with Michelin 26.5R25 XHA2 L3 radial tires, full fluids, operator, standard counterweight, cold start, roading fenders, Product Link, Manual Diff Lock/Open axles (front/rear), power train guard, secondary steering and sound suppression.

**Maximum values.

(With Tire Deflection) Full compliance to ISO 14397-1 (2007) Sections 1 thru 6, which requires 2% verification between calculations and testing. (No Tire Deflection) Compliance to ISO 14397-1 (2007) Sections 1 thru 5.

NOTE: Machine and bucket availability varies by region. Consult your local dealer for availability.

Package Bucket Type		Aggregate Handler		
		General Purpose — Fusion QC		
Edge Type		Bolt-on Cutting Edges	Bolt-on Cutting Edges	Bolt-on Cutting Edges
Capacity — rated	m ³	5.10	5.30	5.50
	yd ³	6.67	6.93	7.19
Capacity — rated at 110% fill factor	m ³	5.61	5.83	6.05
	yd ³	7.34	7.63	7.91
Width	mm	3357	3357	3357
	ft/in	11'0"	11'0"	11'0"
Dump clearance at maximum lift and 45° discharge	mm	3127	3100	3072
	ft/in	10'3"	10'2"	10'0"
Reach at maximum lift and 45° discharge	mm	1375	1399	1424
	ft/in	4'6"	4'7"	4'8"
Reach at level lift arm and bucket level	mm	3046	3083	3121
	ft/in	9'11"	10'1"	10'2"
Digging depth	mm	108	108	108
	in	4.2	4.2	4.2
Shipping length (With Bucket)	mm	9037	9074	9112
	ft/in	29'8"	29'10"	29'11"
Overall height with bucket at maximum lift	mm	6235	6272	6293
	ft/in	20'6"	20'7"	20'8"
Loader clearance circle with bucket at carry position	mm	15 362	15 382	15 403
	ft/in	50'5"	50'6"	50'7"
Static tipping load, straight (With Tire Deflection)*	kg	19 316	19 242	19 172
	lb	42,574	42,409	42,255
Static tipping load, straight (No Tire Deflection)*	kg	20 669	20 600	20 537
	lb	45,556	45,403	45,263
Static tipping load, articulated (With Tire Deflection)*	kg	16 799	16 726	16 658
	lb	37,026	36,865	36,716
Static tipping load, articulated (No Tire Deflection)*	kg	18 165	18 098	18 036
	lb	40,036	39,888	39,753
Breakout force	kN	190	185	180
	lbf	42,755	41,650	40,573
Operating weight*	kg	25 790	25 832	25 870
	lb	56,840	56,933	57,016

*Static tipping loads and operating weights shown are based on a machine configuration with Michelin 26.5R25 XHA2 L3 radial tires, full fluids, operator, standard counterweight, cold start, roading fenders, Product Link, Manual Diff Lock/Open axles (front/rear), power train guard, secondary steering and sound suppression.

(With Tire Deflection) Full compliance to ISO 14397-1 (2007) Sections 1 thru 6, which requires 2% verification between calculations and testing.

(No Tire Deflection) Compliance to ISO 14397-1 (2007) Sections 1 thru 5.

NOTE: Machine and bucket availability varies by region. Consult your local dealer for availability.

Bucket Type		General Purpose – Pin On			Rock – Pin On**			Coal – Pin On	High Lift Delta	
		Bolt-on Cutting Edges	Teeth & Segments	Tips	Bolt-on Cutting Edges	Teeth & Segments	Tips	Bolt-on Cutting Edges		
Edge Type	Capacity – rated	m ³	5.40	5.40	5.00	4.40	4.40	4.30	8.20	–
		yd ³	7.06	7.06	6.54	5.75	5.75	5.62	10.73	–
Capacity – 110%		m ³	5.94	5.94	5.50	4.84	4.84	4.73	9.02	–
		yd ³	7.77	7.77	7.19	6.33	6.33	6.19	11.80	–
Width		mm	3447	3535	3535	3504	3504	3504	3638	–
		ft/in	11'3"	11'7"	11'7"	11'5"	11'5"	11'5"	11'11"	–
Dump clearance at maximum lift and 45° discharge		mm	3273	3107	3107	3101	3101	3101	2917	221
		ft/in	10'8"	10'2"	10'2"	10'2"	10'2"	10'2"	9'6"	8"
Reach at maximum lift and 45° discharge		mm	1481	1618	1618	1769	1769	1769	1625	–
		ft/in	4'10"	5'3"	5'3"	5'9"	5'9"	5'9"	5'3"	–
Reach at level lift arm and bucket level		mm	2965	3177	3177	3285	3285	3285	3336	160
		ft/in	9'8"	10'5"	10'5"	10'9"	10'9"	10'9"	10'11"	6"
Digging depth		mm	103	103	68	106	106	71	108	–
		in	4.0	4.0	2.6	4.1	4.1	2.8	4.2	–
Overall length		mm	9493	9734	9734	9828	9828	9828	9876	201
		ft/in	31'2"	32'0"	32'0"	32'3"	32'3"	32'3"	32'5"	7"
Overall height with bucket at maximum lift		mm	6421	6421	6421	6184	6184	6184	6536	221
		ft/in	21'1"	21'1"	21'1"	20'4"	20'4"	20'4"	21'6"	8"
Loader clearance circle with bucket at carry position		mm	15 223	15 451	15 451	15 469	15 469	15 469	15 609	1009
		ft/in	50'0"	50'9"	50'9"	50'10"	50'9"	50'9"	51'3"	3'3"
Static tipping load, straight (ISO)*		kg	22 639	22 453	22 897	22 987	23 033	23 504	21 615	–2002
		lb	49,897	49,488	50,466	50,664	50,766	51,803	47,639	–4413
Static tipping load, straight (Rigid Tire)*		kg	24 023	23 835	24 297	24 375	24 431	24 912	23 054	–2212
		lb	52,946	52,533	53,551	53,722	53,848	54,907	50,811	–4875
Static tipping load, articulated (ISO)*		kg	19 565	19 379	19 795	19 851	19 875	20 337	18 575	–1365
		lb	43,121	42,712	43,629	43,752	43,806	44,822	40,941	–3008
Static tipping load, articulated (Rigid Tire)*		kg	20 796	20 608	21 040	21 083	21 117	21 587	19 864	–1547
		lb	45,834	45,421	46,373	46,467	46,542	47,578	43,781	–3410
Breakout force (§)		kN	224	222	239	210	210	227	175	19
		lbf	50,466	49,926	53,816	47,384	47,195	51,049	39,467	4190
Operating weight*		kg	30 090	30 228	30 053	30 612	30 687	30 392	30 677	115
		lb	66,318	66,623	66,236	67,469	67,634	66,984	67,612	253

*Static tipping loads and operating weights shown are based on a machine configuration with Michelin 29.5R25 XLDD1 L4 radial tires, full fluids, operator, standard counterweight, cold start, roading fenders, Product Link, limited slip differentials, power train guard, secondary steering and sound suppression.

**Rock bucket specifications are given on Michelin 29.5R25 XLDD2 L5 Radial tires.

(§) Measured 102 mm (4") behind tip of cutting edge with bucket hinge pin as pivot point in accordance with SAE J732C.

(§) Specifications and ratings conform to all applicable standards recommended by the Society of Automotive Engineers, including SAE Standard J732C governing loader ratings.

(ISO) Full compliance to ISO 14397-1 (2007) Sections 1 thru 6, which requires 2% verification between calculations and testing.

(Rigid Tire) Compliance to ISO 14397-1 (2007) Sections 1 thru 5.

NOTE: Machine and bucket availability varies by region. Consult your local dealer for availability.

Bucket Type	General Purpose – Pin On		Material Handling – Pin On	Coal – Pin On
	Bolt-on Cutting Edges	Bolt-on Cutting Edges	Bolt-on Cutting Edges	Bolt-on Cutting Edges
Capacity – rated	m ³	5.70	6.00	5.70
	yd ³	7.46	7.85	7.46
Capacity – 110%	m ³	6.27	6.60	6.27
	yd ³	8.20	8.63	8.20
Width	mm	3447	3447	3447
	ft/in	11'3"	11'3"	11'3"
Dump clearance at maximum lift and 45° discharge	mm	3204	3187	3105
	ft/in	10'6"	10'5"	10'2"
Reach at maximum lift and 45° discharge	mm	1529	1550	1444
	ft/in	5'0"	5'1"	4'8"
Reach at level lift arm and bucket level	mm	3049	3077	3074
	ft/in	10'0"	10'1"	10'1"
Digging depth	mm	103	103	103
	in	4	4	4
Overall length	mm	9638	9666	9663
	ft/in	31'8"	31'9"	31'9"
Overall height with bucket at maximum lift	mm	6243	6269	6242
	ft/in	20'6"	20'7"	20'6"
Loader clearance circle with bucket at carry position	mm	15 270	15 285	15 284
	ft/in	50'2"	50'2"	50'2"
Static tipping load, straight (ISO)*	kg	23 972	23 827	23 447
	lb	52,835	52,515	51,677
Static tipping load, straight (Rigid Tire)*	kg	25 481	25 339	24 909
	lb	56,161	55,847	54,901
Static tipping load, articulated (ISO)*	kg	20 630	20 491	20 163
	lb	45,470	45,162	44,440
Static tipping load, articulated (Rigid Tire)*	kg	21 997	21 860	21 488
	lb	48,482	48,180	47,360
Breakout force (§)	kN	211	207	208
	lbf	47,618	46,676	46,782
Operating weight*	kg	30 822	30 918	30 947
	lb	67,931	68,143	68,207

*Static tipping loads and operating weights shown are based on a machine configuration with Michelin 29.5R25 XLDD1 L4 radial tires, full fluids, operator, aggregate counterweight, cold start, roading fenders, Product Link, limited slip differentials, power train guard, secondary steering and sound suppression. If a rock bucket is added, those values are with Michelin 26.5R25 XLDD2 L5 tires.

**Aggregate Handler configuration is not compatible with teeth and segments, tips, rock buckets, high lift, L5 tires.

(§) Measured 102 mm (4") behind tip of cutting edge with bucket hinge pin as pivot point in accordance with SAE J732C.

(§) Specifications and ratings conform to all applicable standards recommended by the Society of Automotive Engineers, including SAE Standard J732C governing loader ratings.

(ISO) Full compliance to ISO 14397-1 (2007) Sections 1 thru 6, which requires 2% verification between calculations and testing.

(Rigid Tire) Compliance to ISO 14397-1 (2007) Sections 1 thru 5.

NOTE: Machine and bucket availability varies by region. Consult your local dealer for availability.

Bucket Type	General Purpose						
		Bolt-on Cutting Edges	Teeth & Segments	Tips	Bolt-on Cutting Edges	Teeth & Segments	Tips
Edge Type							
Capacity — rated	m ³ yd ³	6.10 7.98	6.10 7.98	5.70 7.46	6.40 8.37	6.40 8.37	6.10 7.98
Capacity — 110%	m ³ yd ³	6.71 8.78	6.71 8.78	6.27 8.20	7.04 9.21	7.04 9.21	6.71 8.78
Width	mm ft/in	3602 11'9"	3665 12'0"	3665 12'0"	3602 11'9"	3665 12'0"	3665 12'0"
Dump clearance at maximum lift and 45° discharge	mm ft/in	3365 11'0"	3197 10'5"	3197 10'5"	3327 10'11"	3159 10'4"	3159 10'4"
Reach at maximum lift and 45° discharge	mm ft/in	1569 5'1"	1703 5'7"	1703 5'7"	1602 5'3"	1735 5'8"	1735 5'8"
Reach at level lift arm and bucket level	mm ft/in	3257 10'8"	3468 11'4"	3468 11'4"	3307 10'10"	3518 11'6"	3518 11'6"
Digging depth	mm in	116 4.5	116 4.5	81 3.2	116 4.5	116 4.5	81 3.2
Overall length	mm ft/in	10 178 33'5"	10 412 34'2"	10 412 34'2"	10 228 33'7"	10 462 34'4"	10 462 34'4"
Overall height with bucket at maximum lift	mm ft/in	6592 21'8"	6592 21'8"	6592 21'8"	6642 21'10"	6642 21'10"	6642 21'10"
Loader clearance circle with bucket at carry position	mm ft/in	15 770 51'9"	15 986 52'6"	15 986 52'6"	15 801 51'11"	16 018 52'7"	16 018 52'7"
Static tipping load, straight (ISO)*	kg lb	24 791 54,640	24 692 54,422	25 112 55,347	24 620 54,264	24 521 54,045	24 952 54,994
Static tipping load, straight (Rigid Tire)*	kg lb	26 101 57,527	26 001 57,308	26 439 58,272	25 938 57,169	25 838 56,948	26 285 57,933
Static tipping load, articulated (ISO)*	kg lb	21 080 46,462	20 981 46,243	21 370 47,100	20 918 46,105	20 819 45,885	21 217 46,763
Static tipping load, articulated (Rigid Tire)*	kg lb	22 393 49,354	22 293 49,135	22 699 50,029	22 239 49,015	22 138 48,794	22 552 49,706
Breakout force (§)	kN lbf	260 58,531	259 58,375	278 62,671	251 56,572	251 56,417	269 60,459
Operating weight*	kg lb	35 563 78,382	35 636 78,542	35 476 78,189	35 655 78,583	35 727 78,742	35 567 78,389

*Static tipping loads and operating weights shown are based on a machine configuration with Bridgestone 875/65R29 VLTS L4 radial tires, full fluids, operator, standard counterweight, cold start, roading fenders, Product Link, limited slip differentials, power train guard, secondary steering and sound suppression.

(§) Measured 102 mm (4") behind tip of cutting edge with bucket hinge pin as pivot point in accordance with SAE J732C.

(§) Specifications and ratings conform to all applicable standards recommended by the Society of Automotive Engineers, including SAE Standard J732C governing loader ratings.

(ISO) Full compliance to ISO 14397-1 (2007) Sections 1 thru 6, which requires 2% verification between calculations and testing.

(Rigid Tire) Compliance to ISO 14397-1 (2007) Sections 1 thru 5.

NOTE: Machine and bucket availability varies by region. Consult your local dealer for availability.

Bucket Type		Heavy Duty Rock			Woodchip	Coal
		Bolt-on Cutting Edges	Teeth & Segments	Tips	Bolt-on Cutting Edges	Bolt-on Cutting Edges
Edge Type						
Capacity — rated	m ³	5.40	5.40	5.10	12.00	8.80
	yd ³	7.06	7.06	6.67	15.70	11.51
Capacity — 110%	m ³	5.94	5.94	5.61	13.20	9.68
	yd ³	7.77	7.77	7.34	17.26	12.66
Width	mm	3648	3648	3648	4174	3639
	ft/in	11'11"	11'11"	11'11"	13'8"	11'11"
Dump clearance at maximum lift and 45° discharge	mm	3253	3136	3136	3022	3017
	ft/in	10'8"	10'3"	10'3"	9'10"	9'10"
Reach at maximum lift and 45° discharge	mm	1794	1915	1915	1738	1743
	ft/in	5'10"	6'3"	6'3"	5'8"	5'8"
Reach at level lift arm and bucket level	mm	3489	3657	3657	3638	3645
	ft/in	11'5"	11'11"	11'11"	11'11"	11'11"
Digging depth	mm	107	107	72	119	119
	in	4.2	4.2	2.8	4.7	4.7
Overall length	mm	10 410	10 586	10 586	10 561	10 568
	ft/in	34'2"	34'9"	34'9"	34'8"	34'9"
Overall height with bucket at maximum lift	mm	6540	6540	6540	7059	6962
	ft/in	21'6"	21'6"	21'6"	23'2"	22'11"
Loader clearance circle with bucket at carry position	mm	15 955	16 073	16 073	16 516	16 049
	ft/in	52'5"	52'9"	52'9"	54'3"	52'8"
Static tipping load, straight (ISO)*	kg	23 940	23 809	24 303	23 472	23 229
	lb	52,764	52,475	53,565	51,734	51,198
Static tipping load, straight (Rigid Tire)*	kg	25 241	25 108	25 614	24 881	24 545
	lb	55,631	55,339	56,454	54,838	54,098
Static tipping load, articulated (ISO)*	kg	20 193	20 062	20 537	19 784	19 630
	lb	44,505	44,217	45,264	43,605	43,264
Static tipping load, articulated (Rigid Tire)*	kg	21 497	21 364	21 851	21 191	20 949
	lb	47,380	47,088	48,160	46,706	46,172
Breakout force (§)	kN	233	232	249	203	203
	lbf	52,456	52,261	56,145	45,653	45,761
Operating weight*	kg	36 601	36 694	36 420	36 512	36 233
	lb	80,669	80,874	80,270	80,473	79,858

*Static tipping loads and operating weights shown are based on a machine configuration with Bridgestone 875/65R29 VLTS L4 radial tires, full fluids, operator, standard counterweight, cold start, roading fenders, Product Link, limited slip differentials, power train guard, secondary steering and sound suppression.

(§) Measured 102 mm (4") behind tip of cutting edge with bucket hinge pin as pivot point in accordance with SAE J732C.

(§) Specifications and ratings conform to all applicable standards recommended by the Society of Automotive Engineers, including SAE Standard J732C governing loader ratings.

(ISO) Full compliance to ISO 14397-1 (2007) Sections 1 thru 6, which requires 2% verification between calculations and testing.

(Rigid Tire) Compliance to ISO 14397-1 (2007) Sections 1 thru 5.

NOTE: Machine and bucket availability varies by region. Consult your local dealer for availability.

Bucket Type		General Purpose				General Purpose – Heavy Duty
		Bolt-on Cutting Edges	Bolt-on Cutting Edges	Bolt-on Cutting Edges	Bolt-on Cutting Edges	Bolt-on Cutting Edges
Edge Type						
Capacity — rated	m ³ yd ³	6.40 8.37	7.00 9.16	7.50 9.81	8.20 10.73	7.50 9.81
Capacity — 110%	m ³ yd ³	7.04 9.21	7.70 10.07	8.25 10.79	9.02 11.80	8.25 10.79
Width	mm ft/in	3602 11'9"	3602 11'9"	3602 11'9"	3602 11'9"	3602 11'9"
Dump clearance at maximum lift and 45° discharge	mm ft/in	3327 10'11"	3277 10'9"	3227 10'7"	3154 10'4"	3236 10'7"
Reach at maximum lift and 45° discharge	mm ft/in	1602 5'3"	1644 5'4"	1689 5'6"	1755 5'9"	1697 5'6"
Reach at level lift arm and bucket level	mm ft/in	3307 10'10"	3374 11'0"	3442 11'3"	3542 11'7"	3442 11'3"
Digging depth	mm in	116 4.5	116 4.5	116 4.5	116 4.5	104 4.1
Overall length	mm ft/in	10 335 33'11"	10 402 34'2"	10 470 34'5"	10 570 34'9"	10 462 34'4"
Overall height with bucket at maximum lift	mm ft/in	6642 21'10"	6709 22'1"	6776 22'3"	6870 22'7"	6779 22'3"
Loader clearance circle with bucket at carry position	mm ft/in	15 801 51'11"	15 842 52'0"	15 885 52'2"	15 948 52'4"	15 876 52'2"
Static tipping load, straight (ISO)*	kg lb	26 038 57,389	25 761 56,779	25 552 56,316	25 217 55,578	24 863 54,799
Static tipping load, straight (Rigid Tire)*	kg lb	27 454 60,510	27 186 59,918	26 985 59,475	26 661 58,762	26 293 57,949
Static tipping load, articulated (ISO)*	kg lb	22 083 48,672	21 816 48,084	21 618 47,647	21 299 46,944	20 924 46,116
Static tipping load, articulated (Rigid Tire)*	kg lb	23 507 51,809	23 249 51,240	23 058 50,821	22 751 50,144	22 361 49,283
Breakout force (§)	kN lbf	251 56,572	240 54,068	230 51,768	216 48,643	227 51,178
Operating weight*	kg lb	36 302 80,009	36 483 80,408	36 589 80,641	36 774 81,049	37 265 82,131

*Static tipping loads and operating weights shown are based on a machine configuration with Bridgestone 875/65R29 VLTS L4 radial tires, full fluids, operator, aggregate counterweight, cold start, roading fenders, Product Link, limited slip differentials, power train guard, secondary steering and sound suppression.

**Aggregate Handler configuration is not compatible with teeth and segments, tips, rock buckets, high lift, L5 tires.

(§) Measured 102 mm (4") behind tip of cutting edge with bucket hinge pin as pivot point in accordance with SAE J732C.

(§) Specifications and ratings conform to all applicable standards recommended by the Society of Automotive Engineers, including SAE Standard J732C governing loader ratings.

(ISO) Full compliance to ISO 14397-1 (2007) Sections 1 thru 6, which requires 2% verification between calculations and testing.

(Rigid Tire) Compliance to ISO 14397-1 (2007) Sections 1 thru 5.

NOTE: Machine and bucket availability varies by region. Consult your local dealer for availability.

Bucket Type	Material Handling — Heavy Duty		Woodchip	Coal
	Bolt-on Cutting Edges	Bolt-on Cutting Edges	Bolt-on Cutting Edges	Bolt-on Cutting Edges
Edge Type				
Capacity — rated	m ³ yd ³	6.40 8.37	7.00 9.16	12.00 15.70
Capacity — 110%	m ³ yd ³	7.04 9.21	7.70 10.07	13.20 17.26
Width	mm ft/in	3602 11'9"	3602 11'9"	4174 13'8"
Dump clearance at maximum lift and 45° discharge	mm ft/in	3264 10'8"	3200 10'6"	3022 9'10"
Reach at maximum lift and 45° discharge	mm ft/in	1518 4'11"	1581 5'2"	1738 5'8"
Reach at level lift arm and bucket level	mm ft/in	3311 10'10"	3401 11'1"	3638 11'11"
Digging depth	mm in	104 4.1	104 4.1	119 4.7
Overall length	mm ft/in	10 331 33'11"	10 421 34'3"	10 668 35'0"
Overall height with bucket at maximum lift	mm ft/in	6622 21'9"	6709 22'1"	7059 23'2"
Loader clearance circle with bucket at carry position	mm ft/in	15 794 51'10"	15 850 52'0"	16 516 54'3"
Static tipping load, straight (ISO)*	kg lb	24 813 54,689	24 471 53,935	24 878 54,831
Static tipping load, straight (RigidTire)*	kg lb	26 181 57,704	25 850 56,973	26 392 58,170
Static tipping load, articulated (ISO)*	kg lb	20 907 46,079	20 578 45,354	20 937 46,145
Static tipping load, articulated (RigidTire)*	kg lb	22 285 49,116	21 966 48,414	22 456 49,493
Breakout force (§)	kN lbf	247 55,612	232 52,320	203 45,653
Operating weight*	kg lb	37 148 81,873	37 355 82,330	37 159 81,899

*Static tipping loads and operating weights shown are based on a machine configuration with Bridgestone 875/65R29 VLTS L4 radial tires, full fluids, operator, aggregate counterweight, cold start, roading fenders, Product Link, limited slip differentials, power train guard, secondary steering and sound suppression.

**Aggregate Handler configuration is not compatible with teeth and segments, tips, rock buckets, high lift, L5 tires.

(§) Measured 102 mm (4") behind tip of cutting edge with bucket hinge pin as pivot point in accordance with SAE J732C.

(§) Specifications and ratings conform to all applicable standards recommended by the Society of Automotive Engineers, including SAE Standard J732C governing loader ratings.

(ISO) Full compliance to ISO 14397-1 (2007) Sections 1 thru 6, which requires 2% verification between calculations and testing.

(RigidTire) Compliance to ISO 14397-1 (2007) Sections 1 thru 5.

NOTE: Machine and bucket availability varies by region. Consult your local dealer for availability.

Bucket Type	General Purpose — Pin On									
		Bolt-on Cutting Edges	Teeth & Segments	Teeth	Bolt-on Cutting Edges	Teeth & Segments	Teeth	Bolt-on Cutting Edges	Teeth & Segments	Teeth
Edge Type										
Capacity — rated (§)	m ³	2.70	2.70	2.50	2.90	2.90	2.70	3.10	3.10	2.90
	yd ³	3.53	3.53	3.27	3.79	3.79	3.53	4.05	4.05	3.79
Capacity — struck (§)	m ³	2.30	2.30	2.11	2.55	2.55	2.33	2.76	2.76	2.54
	yd ³	3.01	3.01	2.76	3.34	3.34	3.05	3.61	3.61	3.32
Width (§)	mm	2927	2994	2994	2927	2994	2994	2927	2994	2994
	ft/in	9'7"	9'9"	9'9"	9'7"	9'9"	9'9"	9'7"	9'9"	9'9"
Dump clearance at maximum lift and 45° discharge (§)	mm	2975	2859	2859	2919	2802	2802	2876	2758	2758
	ft/in	9'9"	9'4"	9'4"	9'6"	9'2"	9'2"	9'5"	9'0"	9'0"
Reach at maximum lift and 45° discharge (§)	mm	1356	1469	1469	1395	1506	1506	1429	1540	1540
	ft/in	4'5"	4'9"	4'9"	4'6"	4'11"	4'11"	4'8"	5'0"	5'0"
Reach at level lift arm and bucket level (§)	mm	2562	2723	2723	2631	2792	2792	2688	2849	2849
	ft/in	8'4"	8'11"	8'11"	8'7"	9'1"	9'1"	8'9"	9'4"	9'4"
Digging depth (§)	mm	90	90	60	90	90	60	90	90	60
	in	3.5	3.5	2.3	3.5	3.5	2.3	3.5	3.5	2.3
Overall length	mm	8036	8209	8209	8105	8278	8278	8162	8335	8335
	ft/in	26'5"	27'0"	27'0"	26'8"	27'2"	27'2"	26'10"	27'5"	27'5"
Overall height with bucket at maximum lift	mm	5392	5392	5392	5464	5464	5464	5525	5525	5525
	ft/in	17'9"	17'9"	17'9"	18'0"	18'0"	18'0"	18'2"	18'2"	18'2"
Loader clearance circle with bucket at carry position (§)	mm	13 689	13 856	13 856	13 729	13 897	13 897	13 762	13 931	13 931
	ft/in	44'11"	45'6"	45'6"	45'1"	45'8"	45'8"	45'2"	45'9"	45'9"
Static tipping load, straight (ISO)*	kg	12 974	12 836	13 135	12 833	12 694	12 985	12 740	12 600	12 883
	lb	28,596	28,291	28,949	28,285	27,977	28,619	28,081	27,770	28,394
Static tipping load, straight (Rigid Tire)*	kg	13 719	13 580	13 887	13 582	13 441	13 740	13 493	13 350	13 641
	lb	30,238	29,930	30,608	29,935	29,624	30,284	29,739	29,425	30,065
Static tipping load, articulated (ISO)*	kg	11 230	11 092	11 372	11 094	10 955	11 228	11 008	10 867	11 132
	lb	24,752	24,447	25,064	24,453	24,145	24,747	24,261	23,951	24,536
Static tipping load, articulated (Rigid Tire)*	kg	11 990	11 850	12 138	11 857	11 716	11 997	11 774	11 632	11 904
	lb	26,427	26,119	26,754	26,134	25,823	26,442	25,951	25,637	26,237
Breakout force** (§)	kN	180	178	197	169	167	184	161	159	175
	lbf	40,442	40,157	44,336	37,997	37,715	41,441	36,203	35,922	39,334
Operating weight*	kg	19 303	19 411	19 254	19 388	19 496	19 339	19 425	19 533	19 376
	lb	42,544	42,782	42,436	42,730	42,968	42,622	42,811	43,049	42,703

*Static tipping loads and operating weights shown are based on a global machine configuration with Michelin 23.5R25 XHA2 L3 Radial tires, full fluids, operator, standard counterweight, standard linkage, cold start, roading fenders, Product Link, open differential axles (front/rear), power train guard, secondary steering, and sound suppression.

**Measured 102 mm (4") behind tip of cutting edge with bucket hinge pin as pivot point in accordance with SAE J732C.

(§) Specifications and ratings conform to all applicable standards recommended by the Society of Automotive Engineers, including SAE Standard J732C governing loader ratings.

(ISO) Full compliance to ISO 14397-1 (2007) Sections 1 thru 6, which requires 2% verification between calculations and testing.

(Rigid Tire) Compliance to ISO 14397-1 (2007) Sections 1 thru 5.

NOTE: Bucket availability varies by region. Consult your local dealer for availability.

Bucket Type		General Purpose — Pin On									
		Bolt-on Cutting Edges	Teeth & Segments	Teeth	Bolt-on Cutting Edges	Teeth & Segments	Teeth	Bolt-on Cutting Edges	Teeth & Segments	Teeth	
Edge Type											
	Capacity — rated (§)	m ³	3.30	3.30	3.10	3.40	3.40	3.20	3.60	3.60	3.40
		yd ³	4.32	4.32	4.05	4.45	4.45	4.19	4.71	4.71	4.45
Capacity — struck (§)		m ³	2.94	2.94	2.72	3.04	3.04	2.81	3.18	3.18	2.94
		yd ³	3.85	3.85	3.56	3.98	3.98	3.68	4.16	4.16	3.85
Width (§)		mm	2927	2994	2994	2927	2994	2994	2927	2994	2994
		ft/in	9'7"	9'9"	9'9"	9'7"	9'9"	9'9"	9'7"	9'9"	9'9"
Dump clearance at maximum lift and 45° discharge (§)		mm	2838	2719	2719	2819	2700	2700	2793	2673	2673
		ft/in	9'3"	8'11"	8'11"	9'3"	8'10"	8'10"	9'1"	8'9"	8'9"
Reach at maximum lift and 45° discharge (§)		mm	1458	1568	1568	1473	1582	1582	1495	1604	1604
		ft/in	4'9"	5'1"	5'1"	4'10"	5'2"	5'2"	4'10"	5'3"	5'3"
Reach at level lift arm and bucket level (§)		mm	2737	2898	2898	2761	2922	2922	2796	2957	2957
		ft/in	8'11"	9'6"	9'6"	9'0"	9'7"	9'7"	9'2"	9'8"	9'8"
Digging depth (§)		mm	90	90	60	90	90	60	90	90	60
		in	3.5	3.5	2.3	3.5	3.5	2.3	3.5	3.5	2.3
Overall length		mm	8211	8384	8384	8235	8408	8408	8270	8443	8443
		ft/in	27'0"	27'7"	27'7"	27'1"	27'8"	27'8"	27'2"	27'9"	27'9"
Overall height with bucket at maximum lift		mm	5571	5571	5571	5597	5597	5597	5630	5630	5630
		ft/in	18'4"	18'4"	18'4"	18'5"	18'5"	18'5"	18'6"	18'6"	18'6"
Loader clearance circle with bucket at carry position (§)		mm	13 791	13 961	13 961	13 805	13 975	13 975	13 826	13 997	13 997
		ft/in	45'3"	45'10"	45'10"	45'4"	45'11"	45'11"	45'5"	46'0"	46'0"
Static tipping load, straight (ISO)*		kg	12 620	12 478	12 759	12 577	12 434	12 712	12 506	12 363	12 638
		lb	27,815	27,503	28,122	27,719	27,406	28,019	27,564	27,249	27,854
Static tipping load, straight (Rigid Tire)*		kg	13 374	13 231	13 519	13 332	13 188	13 473	13 263	13 118	13 400
		lb	29,477	29,161	29,797	29,384	29,067	29,696	29,232	28,914	29,534
Static tipping load, articulated (ISO)*		kg	10 892	10 750	11 014	10 850	10 708	10 969	10 783	10 640	10 898
		lb	24,006	23,694	24,275	23,915	23,601	24,176	23,767	23,452	24,020
Static tipping load, articulated (Rigid Tire)*		kg	11 660	11 517	11 788	11 620	11 476	11 743	11 554	11 410	11 674
		lb	25,700	25,384	25,980	25,611	25,294	25,883	25,467	25,148	25,729
Breakout force** (§)		kN	154	153	167	151	150	164	147	146	159
		lbf	34,742	34,463	37,633	34,071	33,792	36,855	33,133	32,855	35,772
Operating weight*		kg	19 494	19 602	19 445	19 518	19 626	19 469	19 554	19 662	19 505
		lb	42,964	43,202	42,856	43,017	43,255	42,909	43,097	43,335	42,989

*Static tipping loads and operating weights shown are based on a global machine configuration with Michelin 23.5R25 XHA2 L3 Radial tires, full fluids, operator, standard counterweight, standard linkage, cold start, roading fenders, Product Link, open differential axles (front/rear), power train guard, secondary steering, and sound suppression.

**Measured 102 mm (4") behind tip of cutting edge with bucket hinge pin as pivot point in accordance with SAE J732C.

(§) Specifications and ratings conform to all applicable standards recommended by the Society of Automotive Engineers, including SAE Standard J732C governing loader ratings.

(ISO) Full compliance to ISO 14397-1 (2007) Sections 1 thru 6, which requires 2% verification between calculations and testing.

(Rigid Tire) Compliance to ISO 14397-1 (2007) Sections 1 thru 5.

NOTE: Bucket availability varies by region. Consult your local dealer for availability.

Bucket Type	General Purpose — Pin On			Material Handling — Pin On					
	Bolt-on Cutting Edges	Teeth & Segments	Teeth	Bolt-on Cutting Edges	Teeth & Segments	Teeth	Bolt-on Cutting Edges	Teeth & Segments	Teeth
Edge Type									
Capacity — rated (§)	m ³	3.80	3.60	2.70	2.70	2.50	2.90	2.90	2.70
	yd ³	4.97	4.71	3.53	3.53	3.27	3.79	3.79	3.53
Capacity — struck (§)	m ³	3.36	3.12	2.32	2.32	2.11	2.52	2.52	2.31
	yd ³	4.39	4.08	3.03	3.03	2.76	3.30	3.30	3.02
Width (§)	mm	2927	2994	2994	2927	2994	2994	2927	2994
	ft/in	9'7"	9'9"	9'9"	9'7"	9'9"	9'9"	9'7"	9'9"
Dump clearance at maximum lift and 45° discharge (§)	mm	2758	2638	2638	2896	2770	2770	2853	2728
	ft/in	9'0"	8'7"	8'7"	9'6"	9'1"	9'1"	9'4"	8'11"
Reach at maximum lift and 45° discharge (§)	mm	1524	1632	1632	1272	1374	1374	1314	1416
	ft/in	5'0"	5'4"	5'4"	4'2"	4'6"	4'6"	4'3"	4'7"
Reach at level lift arm and bucket level (§)	mm	2842	3003	3003	2581	2742	2742	2641	2802
	ft/in	9'3"	9'10"	9'10"	8'5"	8'11"	8'11"	8'8"	9'2"
Digging depth (§)	mm	90	90	60	90	90	60	90	60
	in	3.5	3.5	2.3	3.5	3.5	2.3	3.5	2.3
Overall length	mm	8316	8489	8489	8055	8228	8228	8115	8288
	ft/in	27'4"	27'11"	27'11"	26'6"	27'0"	27'0"	26'8"	27'3"
Overall height with bucket at maximum lift	mm	5678	5678	5678	5618	5618	5618	4975	4975
	ft/in	18'8"	18'8"	18'8"	18'6"	18'6"	18'6"	16'4"	16'4"
Loader clearance circle with bucket at carry position (§)	mm	13 854	14 025	14 025	13 700	13 868	13 868	13 734	13 903
	ft/in	45'6"	46'1"	46'1"	45'0"	45'6"	45'6"	45'1"	45'8"
Static tipping load, straight (ISO)*	kg	12 407	12 263	12 533	12 803	12 666	12 994	12 688	12 833
	lb	27,345	27,028	27,623	28,219	27,916	28,639	27,965	28,285
Static tipping load, straight (Rigid Tire)*	kg	13 165	13 020	13 297	13 531	13 392	13 730	13 419	13 569
	lb	29,017	28,697	29,307	29,823	29,517	30,263	29,575	29,906
Static tipping load, articulated (ISO)*	kg	10 688	10 545	10 798	11 078	10 941	11 252	10 969	11 098
	lb	23,558	23,241	23,799	24,417	24,115	24,799	24,177	24,460
Static tipping load, articulated (Rigid Tire)*	kg	11 461	11 316	11 575	11 821	11 683	12 003	11 715	11 848
	lb	25,261	24,941	25,512	26,054	25,749	26,456	25,820	26,113
Breakout force** (§)	kN	142	141	153	176	175	193	167	182
	lbf	31,963	31,687	34,427	39,722	39,437	43,481	37,667	41,052
Operating weight*	kg	19 609	19 717	19 560	19 326	19 434	19 277	19 382	19 333
	lb	43,218	43,456	43,110	42,593	42,831	42,485	42,717	42,955

*Static tipping loads and operating weights shown are based on a global machine configuration with Michelin 23.5R25 XHA2 L3 Radial tires, full fluids, operator, standard counterweight, standard linkage, cold start, roading fenders, Product Link, open differential axles (front/rear), power train guard, secondary steering, and sound suppression.

**Measured 102 mm (4") behind tip of cutting edge with bucket hinge pin as pivot point in accordance with SAE J732C.

(§) Specifications and ratings conform to all applicable standards recommended by the Society of Automotive Engineers, including SAE Standard J732C governing loader ratings.

(ISO) Full compliance to ISO 14397-1 (2007) Sections 1 thru 6, which requires 2% verification between calculations and testing.

(Rigid Tire) Compliance to ISO 14397-1 (2007) Sections 1 thru 5.

NOTE: Bucket availability varies by region. Consult your local dealer for availability.

Bucket Type	Material Handling – Pin On									
		Bolt-on Cutting Edges	Teeth & Segments	Teeth	Bolt-on Cutting Edges	Teeth & Segments	Teeth	Bolt-on Cutting Edges	Teeth & Segments	Teeth
Edge Type										
Capacity – rated (§)	m ³	3.10	3.10	2.90	3.30	3.30	3.10	3.40	3.40	3.20
	yd ³	4.05	4.05	3.79	4.32	4.32	4.05	4.45	4.45	4.19
Capacity – struck (§)	m ³	2.61	2.61	2.44	2.78	2.78	2.61	2.92	2.92	2.74
	yd ³	3.41	3.41	3.19	3.64	3.64	3.41	3.82	3.82	3.58
Width (§)	mm	2927	2994	2994	2927	2994	2994	2927	2994	2994
	ft/in	9'7"	9'9"	9'9"	9'7"	9'9"	9'9"	9'7"	9'9"	9'9"
Dump clearance at maximum lift and 45° discharge (§)	mm	2821	2696	2696	2789	2664	2664	2761	2636	2636
	ft/in	9'3"	8'10"	8'10"	9'1"	8'8"	8'8"	9'0"	8'7"	8'7"
Reach at maximum lift and 45° discharge (§)	mm	1346	1448	1448	1378	1480	1480	1406	1508	1508
	ft/in	4'5"	4'9"	4'9"	4'6"	4'10"	4'10"	4'7"	4'11"	4'11"
Reach at level lift arm and bucket level (§)	mm	2686	2847	2847	2731	2892	2892	2771	2932	2932
	ft/in	8'9"	9'4"	9'4"	8'11"	9'5"	9'5"	9'1"	9'7"	9'7"
Digging depth (§)	mm	90	90	60	90	90	60	90	90	60
	in	3.5	3.5	2.3	3.5	3.5	2.3	3.5	3.5	2.3
Overall length	mm	8160	8333	8333	8205	8378	8378	8245	8418	8418
	ft/in	26'10"	27'5"	27'5"	27'0"	27'6"	27'6"	27'1"	27'8"	27'8"
Overall height with bucket at maximum lift	mm	5483	5483	5483	5527	5527	5527	5566	5566	5566
	ft/in	18'0"	18'0"	18'0"	18'2"	18'2"	18'2"	18'4"	18'4"	18'4"
Loader clearance circle with bucket at carry position (§)	mm	13 761	13 930	13 930	13 787	13 957	13 957	13 811	13 981	13 981
	ft/in	45'2"	45'9"	45'9"	45'3"	45'10"	45'10"	45'4"	45'11"	45'11"
Static tipping load, straight (ISO)*	kg	12 595	12 456	12 734	12 504	12 364	12 638	12 426	12 285	12 556
	lb	27,760	27,453	28,066	27,560	27,251	27,855	27,387	27,076	27,673
Static tipping load, straight (Rigid Tire)*	kg	13 328	13 187	13 471	13 239	13 097	13 377	13 162	13 019	13 296
	lb	29,375	29,065	29,691	29,178	28,866	29,484	29,009	28,695	29,305
Static tipping load, articulated (ISO)*	kg	10 881	10 741	11 003	10 794	10 654	10 912	10 719	10 579	10 833
	lb	23,982	23,675	24,251	23,791	23,482	24,050	23,626	23,316	23,877
Static tipping load, articulated (Rigid Tire)*	kg	11 628	11 487	11 755	11 543	11 402	11 665	11 470	11 328	11 588
	lb	25,629	25,319	25,908	25,442	25,130	25,711	25,282	24,968	25,541
Breakout force** (§)	kN	161	160	175	155	154	168	150	149	162
	lbf	36,235	35,954	39,374	34,901	34,621	37,819	33,788	33,510	36,529
Operating weight*	kg	19 432	19 540	19 383	19 480	19 588	19 431	19 520	19 628	19 471
	lb	42,827	43,065	42,719	42,933	43,171	42,825	43,021	43,259	42,913

*Static tipping loads and operating weights shown are based on a global machine configuration with Michelin 23.5R25 XHA2 L3 Radial tires, full fluids, operator, standard counterweight, standard linkage, cold start, roading fenders, Product Link, open differential axles (front/rear), power train guard, secondary steering, and sound suppression.

**Measured 102 mm (4") behind tip of cutting edge with bucket hinge pin as pivot point in accordance with SAE J732C.

(§) Specifications and ratings conform to all applicable standards recommended by the Society of Automotive Engineers, including SAE Standard J732C governing loader ratings.

(ISO) Full compliance to ISO 14397-1 (2007) Sections 1 thru 6, which requires 2% verification between calculations and testing.

(Rigid Tire) Compliance to ISO 14397-1 (2007) Sections 1 thru 5.

NOTE: Bucket availability varies by region. Consult your local dealer for availability.

Bucket Type	Material Handling — Pin On						General Purpose — Fusion QC		
	Bolt-on Cutting Edges	Teeth & Segments	Teeth	Bolt-on Cutting Edges	Teeth & Segments	Teeth	Bolt-on Cutting Edges	Teeth & Segments	Teeth
Edge Type									
Capacity — rated (§)	m ³	3.60	3.40	3.80	3.80	3.60	2.70	2.70	2.50
	yd ³	4.71	4.71	4.45	4.97	4.97	4.71	3.53	3.27
Capacity — struck (§)	m ³	3.15	2.95	3.28	3.28	3.11	2.30	2.30	2.11
	yd ³	4.12	4.12	3.86	4.29	4.29	4.07	3.01	2.76
Width (§)	mm	2927	2994	2994	2927	2994	2927	2994	2994
	ft/in	9'7"	9'9"	9'9"	9'7"	9'9"	9'9"	9'9"	9'9"
Dump clearance at maximum lift and 45° discharge (§)	mm	2729	2604	2604	2693	2568	2936	2820	2820
	ft/in	8'11"	8'6"	8'6"	8'10"	8'5"	9'7"	9'3"	9'3"
Reach at maximum lift and 45° discharge (§)	mm	1438	1540	1540	1474	1576	1402	1516	1516
	ft/in	4'8"	5'0"	5'0"	4'10"	5'2"	4'7"	4'11"	4'11"
Reach at level lift arm and bucket level (§)	mm	2816	2977	2977	2867	3028	2622	2783	2783
	ft/in	9'2"	9'9"	9'9"	9'4"	9'11"	8'7"	9'1"	9'1"
Digging depth (§)	mm	90	90	60	90	90	90	90	60
	in	3.5	3.5	2.3	3.5	3.5	3.5	3.5	2.3
Overall length	mm	8290	8463	8463	8341	8514	8096	8269	8269
	ft/in	27'3"	27'10"	27'10"	27'5"	28'0"	26'7"	27'2"	27'2"
Overall height with bucket at maximum lift	mm	5614	5614	5614	5662	5662	5424	5424	5424
	ft/in	18'6"	18'6"	18'6"	18'7"	18'7"	17'10"	17'10"	17'10"
Loader clearance circle with bucket at carry position (§)	mm	13 838	14 009	14 009	13 869	14 041	13 714	13 884	13 884
	ft/in	45'5"	46'0"	46'0"	45'6"	46'1"	45'0"	45'7"	45'7"
Static tipping load, straight (ISO)*	kg	12 338	12 196	12 463	12 236	12 093	12 356	12 379	12 241
	lb	27,194	26,882	27,470	26,969	26,654	27,234	27,283	26,979
Static tipping load, straight (Rigid Tire)*	kg	13 076	12 933	13 205	12 976	12 832	13 100	13 113	12 974
	lb	28,820	28,504	29,105	28,599	28,281	28,873	28,903	28,596
Static tipping load, articulated (ISO)*	kg	10 636	10 495	10 746	10 539	10 396	10 643	10 661	10 523
	lb	23,443	23,131	23,684	23,228	22,914	23,459	23,497	23,194
Static tipping load, articulated (Rigid Tire)*	kg	11 389	11 246	11 502	11 294	11 150	11 402	11 411	11 271
	lb	25,102	24,787	25,351	24,892	24,574	25,130	25,150	24,843
Breakout force** (§)	kN	145	143	156	139	138	150	170	169
	lbf	32,610	32,333	35,171	31,355	31,079	33,731	38,308	38,025
Operating weight*	kg	19 564	19 672	19 515	19 618	19 726	19 569	19 778	19 729
	lb	43,118	43,356	43,010	43,237	43,475	43,129	43,589	43,481

*Static tipping loads and operating weights shown are based on a global machine configuration with Michelin 23.5R25 XHA2 L3 Radial tires, full fluids, operator, standard counterweight, standard linkage, cold start, roading fenders, Product Link, open differential axles (front/rear), power train guard, secondary steering, and sound suppression.

**Measured 102 mm (4") behind tip of cutting edge with bucket hinge pin as pivot point in accordance with SAE J732C.

(§) Specifications and ratings conform to all applicable standards recommended by the Society of Automotive Engineers, including SAE Standard J732C governing loader ratings.

(ISO) Full compliance to ISO 14397-1 (2007) Sections 1 thru 6, which requires 2% verification between calculations and testing.

(Rigid Tire) Compliance to ISO 14397-1 (2007) Sections 1 thru 5.

NOTE: Bucket availability varies by region. Consult your local dealer for availability.

Bucket Type		General Purpose — Fusion QC									
		Bolt-on Cutting Edges	Teeth & Segments	Teeth	Bolt-on Cutting Edges	Teeth & Segments	Teeth	Bolt-on Cutting Edges	Teeth & Segments	Teeth	
Edge Type											
	Capacity — rated (§)	m ³	2.90	2.90	2.70	3.10	3.10	2.90	3.30	3.30	3.10
		yd ³	3.79	3.79	3.53	4.05	4.05	3.79	4.32	4.32	4.05
Capacity — struck (§)		m ³	2.55	2.55	2.33	2.76	2.76	2.54	2.94	2.94	2.72
		yd ³	3.34	3.34	3.05	3.61	3.61	3.32	3.85	3.85	3.56
Width (§)		mm	2927	2994	2994	2927	2994	2994	2927	2994	2994
		ft/in	9'7"	9'9"	9'9"	9'7"	9'9"	9'9"	9'7"	9'9"	9'9"
Dump clearance at maximum lift and 45° discharge (§)		mm	2880	2763	2763	2837	2718	2718	2798	2679	2679
		ft/in	9'5"	9'0"	9'0"	9'3"	8'11"	8'11"	9'2"	8'9"	8'9"
Reach at maximum lift and 45° discharge (§)		mm	1440	1552	1552	1475	1585	1585	1503	1613	1613
		ft/in	4'8"	5'1"	5'1"	4'10"	5'2"	5'2"	4'11"	5'3"	5'3"
Reach at level lift arm and bucket level (§)		mm	2691	2852	2852	2748	2909	2909	2797	2958	2958
		ft/in	8'9"	9'4"	9'4"	9'0"	9'6"	9'6"	9'2"	9'8"	9'8"
Digging depth (§)		mm	90	90	60	90	90	60	90	90	60
		in	3.5	3.5	2.3	3.5	3.5	2.3	3.5	3.5	2.3
Overall length		mm	8165	8338	8338	8222	8395	8395	8271	8444	8444
		ft/in	26'10"	27'5"	27'5"	27'0"	27'7"	27'7"	27'2"	27'9"	27'9"
Overall height with bucket at maximum lift		mm	5497	5497	5497	5558	5558	5558	5604	5604	5604
		ft/in	18'1"	18'1"	18'1"	18'3"	18'3"	18'3"	18'5"	18'5"	18'5"
Loader clearance circle with bucket at carry position (§)		mm	13 755	13 926	13 926	13 789	13 961	13 961	13 818	13 991	13 991
		ft/in	45'2"	45'9"	45'9"	45'3"	45'10"	45'10"	45'5"	45'11"	45'11"
Static tipping load, straight (ISO)*		kg	12 265	12 125	12 456	12 155	12 015	12 344	12 065	11 924	12 252
		lb	27,032	26,725	27,454	26,790	26,481	27,208	26,591	26,280	27,004
Static tipping load, straight (Rigid Tire)*		kg	13 003	12 862	13 205	12 896	12 754	13 096	12 808	12 665	13 006
		lb	28,659	28,349	29,105	28,423	28,111	28,865	28,230	27,915	28,666
Static tipping load, articulated (ISO)*		kg	10 552	10 413	10 726	10 448	10 308	10 620	10 363	10 221	10 532
		lb	23,257	22,950	23,640	23,029	22,720	23,407	22,840	22,529	23,214
Static tipping load, articulated (Rigid Tire)*		kg	11 305	11 164	11 489	11 204	11 062	11 386	11 120	10 978	11 301
		lb	24,917	24,606	25,323	24,694	24,382	25,096	24,510	24,196	24,908
Breakout force** (§)		kN	160	159	174	153	152	166	147	146	159
		lbf	36,105	35,825	39,220	34,451	34,172	37,295	33,132	32,855	35,769
Operating weight*		kg	19 840	19 948	19 791	19 894	20 002	19 845	19 941	20 049	19 892
		lb	43,727	43,965	43,619	43,847	44,085	43,739	43,949	44,187	43,841

*Static tipping loads and operating weights shown are based on a global machine configuration with Michelin 23.5R25 XHA2 L3 Radial tires, full fluids, operator, standard counterweight, standard linkage, cold start, roading fenders, Product Link, open differential axles (front/rear), power train guard, secondary steering, and sound suppression.

**Measured 102 mm (4") behind tip of cutting edge with bucket hinge pin as pivot point in accordance with SAE J732C.

(§) Specifications and ratings conform to all applicable standards recommended by the Society of Automotive Engineers, including SAE Standard J732C governing loader ratings.

(ISO) Full compliance to ISO 14397-1 (2007) Sections 1 thru 6, which requires 2% verification between calculations and testing.

(Rigid Tire) Compliance to ISO 14397-1 (2007) Sections 1 thru 5.

NOTE: Bucket availability varies by region. Consult your local dealer for availability.

Bucket Type		General Purpose — Fusion QC									
		Bolt-on Cutting Edges	Teeth & Segments	Teeth	Bolt-on Cutting Edges	Teeth & Segments	Teeth	Bolt-on Cutting Edges	Teeth & Segments	Teeth	
Edge Type											
	Capacity — rated (§)	m ³	3.40	3.40	3.20	3.60	3.60	3.40	3.80	3.80	3.60
		yd ³	4.45	4.45	4.19	4.71	4.71	4.45	4.97	4.97	4.71
Capacity — struck (§)		m ³	3.04	3.04	2.81	3.18	3.18	2.94	3.36	3.36	3.12
		yd ³	3.98	3.98	3.68	4.16	4.16	3.85	4.39	4.39	4.08
Width (§)		mm	2927	2994	2994	2927	2994	2994	2927	2994	2994
		ft/in	9'7"	9'9"	9'9"	9'7"	9'9"	9'9"	9'7"	9'9"	9'9"
Dump clearance at maximum lift and 45° discharge (§)		mm	2779	2660	2660	2753	2633	2633	2718	2598	2598
		ft/in	9'1"	8'8"	8'8"	9'0"	8'7"	8'7"	8'11"	8'6"	8'6"
Reach at maximum lift and 45° discharge (§)		mm	1518	1627	1627	1539	1648	1648	1568	1677	1677
		ft/in	4'11"	5'4"	5'4"	5'0"	5'4"	5'4"	5'1"	5'6"	5'6"
Reach at level lift arm and bucket level (§)		mm	2821	2982	2982	2856	3017	3017	2902	3063	3063
		ft/in	9'3"	9'9"	9'9"	9'4"	9'10"	9'10"	9'6"	10'0"	10'0"
Digging depth (§)		mm	90	90	60	90	90	60	90	90	60
		in	3.5	3.5	2.3	3.5	3.5	2.3	3.5	3.5	2.3
Overall length		mm	8295	8468	8468	8330	8503	8503	8376	8549	8549
		ft/in	27'3"	27'10"	27'10"	27'4"	27'11"	27'11"	27'6"	28'1"	28'1"
Overall height with bucket at maximum lift		mm	5630	5630	5630	5664	5664	5664	5711	5711	5711
		ft/in	18'6"	18'6"	18'6"	18'7"	18'7"	18'7"	18'9"	18'9"	18'9"
Loader clearance circle with bucket at carry position (§)		mm	13 833	14 006	14 006	13 854	14 028	14 028	13 883	14 057	14 057
		ft/in	45'5"	46'0"	46'0"	45'6"	46'1"	46'1"	45'7"	46'2"	46'2"
Static tipping load, straight (ISO)*		kg	12 023	11 881	12 209	11 957	11 815	12 142	11 871	11 728	12 054
		lb	26,499	26,187	26,908	26,355	26,041	26,761	26,165	25,849	26,567
Static tipping load, straight (Rigid Tire)*		kg	12 767	12 624	12 964	12 703	12 559	12 898	12 619	12 474	12 812
		lb	28,139	27,823	28,572	27,998	27,681	28,428	27,813	27,494	28,239
Static tipping load, articulated (ISO)*		kg	10 322	10 181	10 491	10 260	10 118	10 428	10 178	10 035	10 344
		lb	22,751	22,439	23,123	22,614	22,301	22,983	22,434	22,118	22,799
Static tipping load, articulated (Rigid Tire)*		kg	11 081	10 938	11 260	11 021	10 877	11 199	10 941	10 796	11 117
		lb	24,424	24,108	24,818	24,290	23,973	24,682	24,114	23,795	24,502
Breakout force** (§)		kN	144	143	156	140	139	151	136	134	146
		lbf	32,517	32,240	35,060	31,655	31,379	34,072	30,581	30,306	32,844
Operating weight*		kg	19 964	20 072	19 915	19 998	20 106	19 949	20 043	20 151	19 994
		lb	44,001	44,239	43,893	44,076	44,314	43,968	44,175	44,413	44,067

*Static tipping loads and operating weights shown are based on a global machine configuration with Michelin 23.5R25 XHA2 L3 Radial tires, full fluids, operator, standard counterweight, standard linkage, cold start, roading fenders, Product Link, open differential axles (front/rear), power train guard, secondary steering, and sound suppression.

**Measured 102 mm (4") behind tip of cutting edge with bucket hinge pin as pivot point in accordance with SAE J732C.

(§) Specifications and ratings conform to all applicable standards recommended by the Society of Automotive Engineers, including SAE Standard J732C governing loader ratings.

(ISO) Full compliance to ISO 14397-1 (2007) Sections 1 thru 6, which requires 2% verification between calculations and testing.

(Rigid Tire) Compliance to ISO 14397-1 (2007) Sections 1 thru 5.

NOTE: Bucket availability varies by region. Consult your local dealer for availability.

Bucket Type		Material Handling — Fusion QC									
		Bolt-on Cutting Edges	Teeth & Segments	Teeth	Bolt-on Cutting Edges	Teeth & Segments	Teeth	Bolt-on Cutting Edges	Teeth & Segments	Teeth	
Edge Type											
	Capacity — rated (§)	m ³	2.70	2.70	2.50	2.90	2.90	2.70	3.10	3.10	2.90
		yd ³	3.53	3.53	3.27	3.79	3.79	3.53	4.05	4.05	3.79
Capacity — struck (§)		m ³	2.20	2.20	2.00	2.40	2.40	2.20	2.61	2.61	2.44
		yd ³	2.88	2.88	2.62	3.14	3.14	2.88	3.41	3.41	3.19
Width (§)		mm	2927	2994	2994	2927	2994	2994	2927	2994	2994
		ft/in	9'7"	9'9"	9'9"	9'7"	9'9"	9'9"	9'7"	9'9"	9'9"
Dump clearance at maximum lift and 45° discharge (§)		mm	2853	2728	2728	2811	2685	2685	2779	2653	2653
		ft/in	9'4"	8'11"	8'11"	9'2"	8'9"	8'9"	9'1"	8'8"	8'8"
Reach at maximum lift and 45° discharge (§)		mm	1314	1416	1416	1357	1459	1459	1389	1491	1491
		ft/in	4'3"	4'7"	4'7"	4'5"	4'9"	4'9"	4'6"	4'10"	4'10"
Reach at level lift arm and bucket level (§)		mm	2641	2802	2802	2701	2862	2862	2746	2907	2907
		ft/in	8'8"	9'2"	9'2"	8'10"	9'4"	9'4"	9'0"	9'6"	9'6"
Digging depth (§)		mm	90	90	60	90	90	60	90	90	60
		in	3.5	3.5	2.3	3.5	3.5	2.3	3.5	3.5	2.3
Overall length		mm	8115	8288	8288	8175	8348	8348	8220	8393	8393
		ft/in	26'8"	27'3"	27'3"	26'10"	27'5"	27'5"	27'0"	27'7"	27'7"
Overall height with bucket at maximum lift		mm	5418	5418	5418	5480	5480	5480	5517	5517	5517
		ft/in	17'10"	17'10"	17'10"	18'0"	18'0"	18'0"	18'2"	18'2"	18'2"
Loader clearance circle with bucket at carry position (§)		mm	13 725	13 895	13 895	13 761	13 932	13 932	13 788	13 959	13 959
		ft/in	45'1"	45'8"	45'8"	45'2"	45'9"	45'9"	45'3"	45'10"	45'10"
Static tipping load, straight (ISO)*		kg	12 234	12 097	12 417	12 130	11 992	12 308	12 038	11 899	12 216
		lb	26,965	26,663	27,367	26,734	26,430	27,127	26,533	26,227	26,924
Static tipping load, straight (Rigid Tire)*		kg	12 953	12 815	13 144	12 851	12 711	13 038	12 761	12 621	12 947
		lb	28,548	28,244	28,970	28,323	28,016	28,736	28,125	27,816	28,536
Static tipping load, articulated (ISO)*		kg	10 535	10 398	10 701	10 436	10 298	10 598	10 349	10 210	10 510
		lb	23,220	22,918	23,586	23,001	22,697	23,359	22,809	22,504	23,165
Static tipping load, articulated (Rigid Tire)*		kg	11 269	11 131	11 444	11 172	11 033	11 343	11 087	10 947	11 257
		lb	24,837	24,533	25,222	24,624	24,317	25,001	24,436	24,127	24,811
Breakout force** (§)		kN	167	166	182	159	158	173	153	152	166
		lbf	37,672	37,389	41,057	35,805	35,524	38,869	34,496	34,217	37,348
Operating weight*		kg	19 784	19 892	19 735	19 836	19 944	19 787	19 885	19 993	19 836
		lb	43,602	43,840	43,494	43,717	43,955	43,609	43,825	44,063	43,717

*Static tipping loads and operating weights shown are based on a global machine configuration with Michelin 23.5R25 XHA2 L3 Radial tires, full fluids, operator, standard counterweight, standard linkage, cold start, roading fenders, Product Link, open differential axles (front/rear), power train guard, secondary steering, and sound suppression.

**Measured 102 mm (4") behind tip of cutting edge with bucket hinge pin as pivot point in accordance with SAE J732C.

(§) Specifications and ratings conform to all applicable standards recommended by the Society of Automotive Engineers, including SAE Standard J732C governing loader ratings.

(ISO) Full compliance to ISO 14397-1 (2007) Sections 1 thru 6, which requires 2% verification between calculations and testing.

(Rigid Tire) Compliance to ISO 14397-1 (2007) Sections 1 thru 5.

NOTE: Bucket availability varies by region. Consult your local dealer for availability.

Bucket Type	Material Handling — Fusion QC						
	Bolt-on Cutting Edges	Teeth & Segments	Teeth	Bolt-on Cutting Edges	Teeth & Segments	Teeth	
Edge Type							
Capacity — rated (§)	m ³	3.30	3.30	3.10	3.40	3.40	3.20
	yd ³	4.32	4.32	4.05	4.45	4.45	4.19
Capacity — struck (§)	m ³	2.78	2.78	2.61	2.92	2.92	2.74
	yd ³	3.64	3.64	3.41	3.82	3.82	3.58
Width (§)	mm	2927	2994	2994	2927	2994	2994
	ft/in	9'7"	9'9"	9'9"	9'7"	9'9"	9'9"
Dump clearance at maximum lift and 45° discharge (§)	mm	2747	2622	2622	2719	2593	2593
	ft/in	9'0"	8'7"	8'7"	8'11"	8'6"	8'6"
Reach at maximum lift and 45° discharge (§)	mm	1420	1523	1523	1449	1551	1551
	ft/in	4'7"	4'11"	4'11"	4'9"	5'1"	5'1"
Reach at level lift arm and bucket level (§)	mm	2791	2952	2952	2831	2992	2992
	ft/in	9'1"	9'8"	9'8"	9'3"	9'9"	9'9"
Digging depth (§)	mm	90	90	60	90	90	60
	in	3.5	3.5	2.3	3.5	3.5	2.3
Overall length	mm	8265	8438	8438	8305	8478	8478
	ft/in	27'2"	27'9"	27'9"	27'3"	27'10"	27'10"
Overall height with bucket at maximum lift	mm	5561	5561	5561	5600	5600	5600
	ft/in	18'3"	18'3"	18'3"	18'5"	18'5"	18'5"
Loader clearance circle with bucket at carry position (§)	mm	13 815	13 987	13 987	13 839	14 012	14 012
	ft/in	45'4"	45'11"	45'11"	45'5"	46'0"	46'0"
Static tipping load, straight (ISO)*	kg	11 952	11 812	12 132	11 881	11 740	12 057
	lb	26,342	26,034	26,739	26,186	25,876	26,574
Static tipping load, straight (Rigid Tire)*	kg	12 676	12 535	12 866	12 607	12 465	12 792
	lb	27,938	27,627	28,357	27,786	27,474	28,194
Static tipping load, articulated (ISO)*	kg	10 267	10 127	10 431	10 199	10 059	10 360
	lb	22,629	22,321	22,990	22,480	22,171	22,833
Static tipping load, articulated (Rigid Tire)*	kg	11 006	10 865	11 180	10 941	10 799	11 110
	lb	24,259	23,948	24,641	24,114	23,802	24,487
Breakout force** (§)	kN	148	146	159	143	142	154
	lbf	33,277	32,999	35,937	32,256	31,979	34,761
Operating weight*	kg	19 929	20 037	19 880	19 967	20 075	19 918
	lb	43,922	44,160	43,814	44,006	44,244	43,898

*Static tipping loads and operating weights shown are based on a global machine configuration with Michelin 23.5R25 XHA2 L3 Radial tires, full fluids, operator, standard counterweight, standard linkage, cold start, roading fenders, Product Link, open differential axles (front/rear), power train guard, secondary steering, and sound suppression.

**Measured 102 mm (4") behind tip of cutting edge with bucket hinge pin as pivot point in accordance with SAE J732C.

(§) Specifications and ratings conform to all applicable standards recommended by the Society of Automotive Engineers, including SAE Standard J732C governing loader ratings.

(ISO) Full compliance to ISO 14397-1 (2007) Sections 1 thru 6, which requires 2% verification between calculations and testing.

(Rigid Tire) Compliance to ISO 14397-1 (2007) Sections 1 thru 5.

NOTE: Bucket availability varies by region. Consult your local dealer for availability.

Bucket Type	Material Handling — Fusion QC						High Lift Change in Specs
	Bolt-on Cutting Edges	Teeth & Segments	Teeth	Bolt-on Cutting Edges	Teeth & Segments	Teeth	
Edge Type							
Capacity — rated (§)	m ³	3.60	3.60	3.40	3.80	3.80	3.60
	yd ³	4.71	4.71	4.45	4.97	4.97	4.71
Capacity — struck (§)	m ³	3.10	3.10	2.90	3.28	3.28	3.11
	yd ³	4.05	4.05	3.79	4.29	4.29	4.07
Width (§)	mm	2927	2994	2994	2927	2994	2994
	ft/in	9'7"	9'9"	9'9"	9'7"	9'9"	9'9"
Dump clearance at maximum lift and 45° discharge (§)	mm	2687	2561	2561	2651	2525	2525
	ft/in	8'9"	8'4"	8'4"	8'8"	8'3"	8'3"
Reach at maximum lift and 45° discharge (§)	mm	1480	1583	1583	1517	1619	1619
	ft/in	4'10"	5'2"	5'2"	4'11"	5'3"	5'3"
Reach at level lift arm and bucket level (§)	mm	2876	3037	3037	2927	3088	3088
	ft/in	9'5"	9'11"	9'11"	9'7"	10'1"	10'1"
Digging depth (§)	mm	90	90	60	90	90	60
	in	3.5	3.5	2.3	3.5	3.5	2.3
Overall length	mm	8350	8523	8523	8401	8574	8574
	ft/in	27'5"	28'0"	28'0"	27'7"	28'2"	28'2"
Overall height with bucket at maximum lift	mm	5643	5643	5643	5697	5697	5697
	ft/in	18'7"	18'7"	18'7"	18'9"	18'9"	18'9"
Loader clearance circle with bucket at carry position (§)	mm	13 867	14 040	14 040	13 898	14 073	14 073
	ft/in	45'6"	46'1"	46'1"	45'8"	46'3"	46'3"
Static tipping load, straight (ISO)*	kg	11 798	11 657	11 974	11 700	11 558	11 875
	lb	26,004	25,693	26,392	25,787	25,474	26,172
Static tipping load, straight (Rigid Tire)*	kg	12 526	12 383	12 711	12 429	12 286	12 614
	lb	27,608	27,293	28,016	27,394	27,078	27,801
Static tipping load, articulated (ISO)*	kg	10 122	9980	10 282	10 028	9886	10 187
	lb	22,309	21,998	22,661	22,101	21,788	22,452
Static tipping load, articulated (Rigid Tire)*	kg	10 864	10 722	11 034	10 772	10 629	10 941
	lb	23,946	23,631	24,319	23,743	23,426	24,114
Breakout force** (§)	kN	138	137	149	133	132	143
	lbf	31,176	30,901	33,524	30,013	29,739	32,198
Operating weight*	kg	20 007	20 115	19 958	20 061	20 169	20 012
	lb	44,094	44,332	43,986	44,213	44,451	44,105

*Static tipping loads and operating weights shown are based on a global machine configuration with Michelin 23.5R25 XHA2 L3 Radial tires, full fluids, operator, standard counterweight, standard linkage, cold start, roading fenders, Product Link, open differential axles (front/rear), power train guard, secondary steering, and sound suppression.

**Measured 102 mm (4") behind tip of cutting edge with bucket hinge pin as pivot point in accordance with SAE J732C.

(§) Specifications and ratings conform to all applicable standards recommended by the Society of Automotive Engineers, including SAE Standard J732C governing loader ratings.

(ISO) Full compliance to ISO 14397-1 (2007) Sections 1 thru 6, which requires 2% verification between calculations and testing.

(Rigid Tire) Compliance to ISO 14397-1 (2007) Sections 1 thru 5.

NOTE: Bucket availability varies by region. Consult your local dealer for availability.

Bucket Type	General Purpose — Pin On									
		Bolt-on Cutting Edges	Teeth & Segments	Teeth	Bolt-on Cutting Edges	Teeth & Segments	Teeth	Bolt-on Cutting Edges	Teeth & Segments	Teeth
Edge Type										
Capacity — rated (§)	m ³	2.70	2.70	2.50	2.90	2.90	2.70	3.10	3.10	2.90
	yd ³	3.53	3.53	3.27	3.79	3.79	3.53	4.05	4.05	3.79
Capacity — struck (§)	m ³	2.30	2.30	2.11	2.55	2.55	2.33	2.76	2.76	2.54
	yd ³	3.01	3.01	2.76	3.34	3.34	3.05	3.61	3.61	3.32
Width (§)	mm	2927	2994	2994	2927	2994	2994	2927	2994	2994
	ft/in	9'7"	9'9"	9'9"	9'7"	9'9"	9'9"	9'7"	9'9"	9'9"
Dump clearance at maximum lift and 45° discharge (§)	mm	3191	3076	3076	3136	3019	3019	3093	2975	2975
	ft/in	10'5"	10'1"	10'1"	10'3"	9'10"	9'10"	10'1"	9'9"	9'9"
Reach at maximum lift and 45° discharge (§)	mm	1290	1403	1403	1328	1440	1440	1363	1474	1474
	ft/in	4'2"	4'7"	4'7"	4'4"	4'8"	4'8"	4'5"	4'10"	4'10"
Reach at level lift arm and bucket level (§)	mm	2660	2821	2821	2729	2890	2890	2786	2947	2947
	ft/in	8'8"	9'3"	9'3"	8'11"	9'5"	9'5"	9'1"	9'8"	9'8"
Digging depth (§)	mm	88	88	58	88	88	58	88	88	58
	in	3.5	3.5	2.3	3.5	3.5	2.3	3.5	3.5	2.3
Overall length	mm	8307	8479	8479	8376	8548	8548	8433	8605	8605
	ft/in	27'4"	27'10"	27'10"	27'6"	28'1"	28'1"	27'8"	28'3"	28'3"
Overall height with bucket at maximum lift	mm	5609	5609	5609	5681	5681	5681	5742	5742	5742
	ft/in	18'5"	18'5"	18'5"	18'8"	18'8"	18'8"	18'11"	18'11"	18'11"
Loader clearance circle with bucket at carry position (§)	mm	13 785	13 953	13 953	13 825	13 995	13 995	13 859	14 029	14 029
	ft/in	45'3"	45'10"	45'10"	45'5"	45'11"	45'11"	45'6"	46'1"	46'1"
Static tipping load, straight (ISO)*	kg	14 003	13 866	14 174	13 854	13 716	14 017	13 753	13 613	13 906
	lb	30,863	30,561	31,240	30,536	30,230	30,893	30,312	30,005	30,651
Static tipping load, straight (Rigid Tire)*	kg	14 746	14 608	14 925	14 601	14 461	14 770	14 502	14 362	14 662
	lb	32,501	32,196	32,895	32,180	31,872	32,553	31,964	31,654	32,316
Static tipping load, articulated (ISO)*	kg	12 053	11 916	12 203	11 910	11 772	12 053	11 816	11 677	11 950
	lb	26,565	26,262	26,897	26,251	25,946	26,565	26,043	25,736	26,339
Static tipping load, articulated (Rigid Tire)*	kg	12 817	12 679	12 974	12 678	12 538	12 827	12 587	12 446	12 726
	lb	28,249	27,944	28,596	27,942	27,634	28,270	27,742	27,431	28,050
Breakout force** (§)	kN	195	194	214	183	182	200	175	174	190
	lbf	43,943	43,707	48,225	41,302	41,066	45,092	39,361	39,125	42,810
Operating weight*	kg	20 252	20 360	20 203	20 336	20 444	20 287	20 373	20 481	20 324
	lb	44,634	44,872	44,526	44,821	45,059	44,713	44,902	45,140	44,794

*Static tipping loads and operating weights shown are based on a global machine configuration with Michelin 23.5R25 XHA2 L3 Radial tires, full fluids, operator, standard counterweight, standard linkage, cold start, roading fenders, Product Link, open differential axles (front/rear), power train guard, secondary steering, and sound suppression.

**Measured 102 mm (4") behind tip of cutting edge with bucket hinge pin as pivot point in accordance with SAE J732C.

(§) Specifications and ratings conform to all applicable standards recommended by the Society of Automotive Engineers, including SAE Standard J732C governing loader ratings.

(ISO) Full compliance to ISO 14397-1 (2007) Sections 1 thru 6, which requires 2% verification between calculations and testing.

(Rigid Tire) Compliance to ISO 14397-1 (2007) Sections 1 thru 5.

NOTE: Bucket availability varies by region. Consult your local dealer for availability.

Bucket Type		General Purpose — Pin On									
		Bolt-on Cutting Edges	Teeth & Segments	Teeth	Bolt-on Cutting Edges	Teeth & Segments	Teeth	Bolt-on Cutting Edges	Teeth & Segments	Teeth	
Edge Type											
	Capacity — rated (§)	m ³	3.30	3.30	3.10	3.40	3.40	3.20	3.60	3.60	3.40
		yd ³	4.32	4.32	4.05	4.45	4.45	4.19	4.71	4.71	4.45
Capacity — struck (§)		m ³	2.94	2.94	2.72	3.04	3.04	2.81	3.18	3.18	2.94
		yd ³	3.85	3.85	3.56	3.98	3.98	3.68	4.16	4.16	3.85
Width (§)		mm	2927	2994	2994	2927	2994	2994	2927	2994	2994
		ft/in	9'7"	9'9"	9'9"	9'7"	9'9"	9'9"	9'7"	9'9"	9'9"
Dump clearance at maximum lift and 45° discharge (§)		mm	3054	2936	2936	3036	2917	2917	3010	2890	2890
		ft/in	10'0"	9'7"	9'7"	9'11"	9'6"	9'6"	9'10"	9'5"	9'5"
Reach at maximum lift and 45° discharge (§)		mm	1392	1502	1502	1406	1516	1516	1428	1537	1537
		ft/in	4'6"	4'11"	4'11"	4'7"	4'11"	4'11"	4'8"	5'0"	5'0"
Reach at level lift arm and bucket level (§)		mm	2835	2996	2996	2859	3020	3020	2894	3055	3055
		ft/in	9'3"	9'9"	9'9"	9'4"	9'10"	9'10"	9'5"	10'0"	10'0"
Digging depth (§)		mm	88	88	58	88	88	58	88	88	58
		in	3.5	3.5	2.3	3.5	3.5	2.3	3.5	3.5	2.3
Overall length		mm	8482	8654	8654	8506	8678	8678	8541	8713	8713
		ft/in	27'10"	28'5"	28'5"	27'11"	28'6"	28'6"	28'1"	28'8"	28'8"
Overall height with bucket at maximum lift		mm	5788	5788	5788	5813	5813	5813	5847	5847	5847
		ft/in	19'0"	19'0"	19'0"	19'1"	19'1"	19'1"	19'3"	19'3"	19'3"
Loader clearance circle with bucket at carry position (§)		mm	13 888	14 059	14 059	13 903	14 074	14 074	13 924	14 095	14 095
		ft/in	45'7"	46'2"	46'2"	45'8"	46'3"	46'3"	45'9"	46'3"	46'3"
Static tipping load, straight (ISO)*		kg	13 626	13 486	13 777	13 580	13 439	13 728	13 505	13 364	13 649
		lb	30,033	29,724	30,365	29,932	29,621	30,256	29,766	29,454	30,082
Static tipping load, straight (Rigid Tire)*		kg	14 377	14 236	14 534	14 332	14 190	14 485	14 259	14 116	14 408
		lb	31,688	31,376	32,034	31,589	31,276	31,926	31,427	31,112	31,755
Static tipping load, articulated (ISO)*		kg	11 695	11 555	11 827	11 652	11 511	11 780	11 581	11 439	11 705
		lb	25,777	25,468	26,068	25,681	25,370	25,964	25,525	25,213	25,799
Static tipping load, articulated (Rigid Tire)*		kg	12 467	12 326	12 605	12 425	12 283	12 558	12 355	12 212	12 485
		lb	27,479	27,167	27,781	27,385	27,071	27,679	27,232	26,917	27,517
Breakout force** (§)		kN	168	167	182	164	163	178	160	159	173
		lbf	37,784	37,548	40,971	37,060	36,824	40,130	36,047	35,811	38,958
Operating weight*		kg	20 443	20 551	20 394	20 466	20 574	20 417	20 503	20 611	20 454
		lb	45,055	45,293	44,947	45,108	45,346	45,000	45,188	45,426	45,080

*Static tipping loads and operating weights shown are based on a global machine configuration with Michelin 23.5R25 XHA2 L3 Radial tires, full fluids, operator, standard counterweight, standard linkage, cold start, roading fenders, Product Link, open differential axles (front/rear), power train guard, secondary steering, and sound suppression.

**Measured 102 mm (4") behind tip of cutting edge with bucket hinge pin as pivot point in accordance with SAE J732C.

(§) Specifications and ratings conform to all applicable standards recommended by the Society of Automotive Engineers, including SAE Standard J732C governing loader ratings.

(ISO) Full compliance to ISO 14397-1 (2007) Sections 1 thru 6, which requires 2% verification between calculations and testing.

(Rigid Tire) Compliance to ISO 14397-1 (2007) Sections 1 thru 5.

NOTE: Bucket availability varies by region. Consult your local dealer for availability.

Bucket Type	General Purpose — Pin On			Material Handling — Pin On						
	Bolt-on Cutting Edges	Teeth & Segments	Teeth	Bolt-on Cutting Edges	Teeth & Segments	Teeth	Bolt-on Cutting Edges	Teeth & Segments	Teeth	
Edge Type										
Capacity — rated (§)	m ³	3.80	3.80	3.60	2.70	2.70	2.50	2.90	2.90	2.70
	yd ³	4.97	4.97	4.71	3.53	3.53	3.27	3.79	3.79	3.53
Capacity — struck (§)	m ³	3.36	3.36	3.12	2.32	2.32	2.11	2.52	2.52	2.31
	yd ³	4.39	4.39	4.08	3.03	3.03	2.76	3.30	3.30	3.02
Width (§)	mm	2927	2994	2994	2927	2994	2994	2927	2994	2994
	ft/in	9'7"	9'9"	9'9"	9'7"	9'9"	9'9"	9'7"	9'9"	9'9"
Dump clearance at maximum lift and 45° discharge (§)	mm	2975	2855	2855	3112	2987	2987	3070	2944	2944
	ft/in	9'9"	9'4"	9'4"	10'2"	9'9"	9'9"	10'0"	9'7"	9'7"
Reach at maximum lift and 45° discharge (§)	mm	1457	1566	1566	1206	1308	1308	1248	1350	1350
	ft/in	4'9"	5'1"	5'1"	3'11"	4'3"	4'3"	4'1"	4'5"	4'5"
Reach at level lift arm and bucket level (§)	mm	2940	3101	3101	2679	2840	2840	2739	2900	2900
	ft/in	9'7"	10'2"	10'2"	8'9"	9'3"	9'3"	8'11"	9'6"	9'6"
Digging depth (§)	mm	88	88	58	88	88	58	88	88	58
	in	3.5	3.5	2.3	3.5	3.5	2.3	3.5	3.5	2.3
Overall length	mm	8587	8759	8759	8326	8498	8498	8386	8558	8558
	ft/in	28'3"	28'9"	28'9"	27'4"	27'11"	27'11"	27'7"	28'1"	28'1"
Overall height with bucket at maximum lift	mm	5894	5894	5894	5835	5835	5835	5192	5192	5192
	ft/in	19'5"	19'5"	19'5"	19'2"	19'2"	19'2"	17'1"	17'1"	17'1"
Loader clearance circle with bucket at carry position (§)	mm	13 952	14 124	14 124	13 796	13 965	13 965	13 831	14 001	14 001
	ft/in	45'10"	46'5"	46'5"	45'4"	45'10"	45'10"	45'5"	46'0"	46'0"
Static tipping load, straight (ISO)*	kg	13 400	13 258	13 538	13 829	13 693	14 027	13 706	13 569	13 862
	lb	29,534	29,220	29,838	30,480	30,180	30,917	30,209	29,906	30,553
Static tipping load, straight (Rigid Tire)*	kg	14 155	14 011	14 298	14 556	14 418	14 763	14 435	14 296	14 596
	lb	31,198	30,881	31,514	32,081	31,778	32,538	31,815	31,510	32,171
Static tipping load, articulated (ISO)*	kg	11 481	11 339	11 600	11 899	11 763	12 078	11 783	11 646	11 921
	lb	25,304	24,991	25,568	26,226	25,926	26,622	25,971	25,668	26,275
Static tipping load, articulated (Rigid Tire)*	kg	12 257	12 113	12 381	12 647	12 510	12 835	12 534	12 395	12 676
	lb	27,015	26,698	27,289	27,874	27,572	28,289	27,624	27,319	27,939
Breakout force** (§)	kN	154	153	166	192	191	210	182	181	198
	lbf	34,784	34,548	37,504	43,166	42,930	47,301	40,945	40,709	44,671
Operating weight*	kg	20 558	20 666	20 509	20 274	20 382	20 225	20 330	20 438	20 281
	lb	45,308	45,546	45,200	44,684	44,922	44,576	44,807	45,045	44,699

*Static tipping loads and operating weights shown are based on a global machine configuration with Michelin 23.5R25 XHA2 L3 Radial tires, full fluids, operator, standard counterweight, standard linkage, cold start, roading fenders, Product Link, open differential axles (front/rear), power train guard, secondary steering, and sound suppression.

**Measured 102 mm (4") behind tip of cutting edge with bucket hinge pin as pivot point in accordance with SAE J732C.

(§) Specifications and ratings conform to all applicable standards recommended by the Society of Automotive Engineers, including SAE Standard J732C governing loader ratings.

(ISO) Full compliance to ISO 14397-1 (2007) Sections 1 thru 6, which requires 2% verification between calculations and testing.

(Rigid Tire) Compliance to ISO 14397-1 (2007) Sections 1 thru 5.

NOTE: Bucket availability varies by region. Consult your local dealer for availability.

Bucket Type	Material Handling – Pin On									
		Bolt-on Cutting Edges	Teeth & Segments	Teeth	Bolt-on Cutting Edges	Teeth & Segments	Teeth	Bolt-on Cutting Edges	Teeth & Segments	Teeth
Edge Type										
Capacity — rated (§)	m ³	3.10	3.10	2.90	3.30	3.30	3.10	3.40	3.40	3.20
	yd ³	4.05	4.05	3.79	4.32	4.32	4.05	4.45	4.45	4.19
Capacity — struck (§)	m ³	2.61	2.61	2.44	2.78	2.78	2.61	2.92	2.92	2.74
	yd ³	3.41	3.41	3.19	3.64	3.64	3.41	3.82	3.82	3.58
Width (§)	mm	2927	2994	2994	2927	2994	2994	2927	2994	2994
	ft/in	9'7"	9'9"	9'9"	9'7"	9'9"	9'9"	9'7"	9'9"	9'9"
Dump clearance at maximum lift and 45° discharge (§)	mm	3038	2913	2913	3006	2881	2881	2978	2852	2852
	ft/in	9'11"	9'6"	9'6"	9'10"	9'5"	9'5"	9'9"	9'4"	9'4"
Reach at maximum lift and 45° discharge (§)	mm	1280	1382	1382	1312	1414	1414	1340	1442	1442
	ft/in	4'2"	4'6"	4'6"	4'3"	4'7"	4'7"	4'4"	4'8"	4'8"
Reach at level lift arm and bucket level (§)	mm	2784	2945	2945	2829	2990	2990	2869	3030	3030
	ft/in	9'1"	9'7"	9'7"	9'3"	9'9"	9'9"	9'4"	9'11"	9'11"
Digging depth (§)	mm	88	88	58	88	88	58	88	88	58
	in	3.5	3.5	2.3	3.5	3.5	2.3	3.5	3.5	2.3
Overall length	mm	8431	8603	8603	8476	8648	8648	8516	8688	8688
	ft/in	27'8"	28'3"	28'3"	27'10"	28'5"	28'5"	28'0"	28'7"	28'7"
Overall height with bucket at maximum lift	mm	5700	5700	5700	5744	5744	5744	5783	5783	5783
	ft/in	18'9"	18'9"	18'9"	18'11"	18'11"	18'11"	19'0"	19'0"	19'0"
Loader clearance circle with bucket at carry position (§)	mm	13 858	14 028	14 028	13 885	14 055	14 055	13 909	14 080	14 080
	ft/in	45'6"	46'1"	46'1"	45'7"	46'2"	46'2"	45'8"	46'3"	46'3"
Static tipping load, straight (ISO)*	kg	13 608	13 469	13 757	13 511	13 372	13 656	13 427	13 288	13 568
	lb	29,992	29,687	30,321	29,778	29,472	30,099	29,594	29,287	29,905
Static tipping load, straight (Rigid Tire)*	kg	14 338	14 199	14 493	14 243	14 103	14 393	14 161	14 020	14 307
	lb	31,602	31,295	31,942	31,392	31,083	31,723	31,211	30,901	31,533
Static tipping load, articulated (ISO)*	kg	11 690	11 552	11 822	11 599	11 460	11 726	11 520	11 380	11 643
	lb	25,766	25,461	26,055	25,564	25,258	25,845	25,390	25,082	25,662
Static tipping load, articulated (Rigid Tire)*	kg	12 442	12 303	12 578	12 352	12 212	12 484	12 275	12 134	12 402
	lb	27,423	27,116	27,723	27,225	26,916	27,515	27,054	26,744	27,336
Breakout force** (§)	kN	175	174	190	168	167	183	163	162	177
	lbf	39,398	39,162	42,855	37,957	37,721	41,173	36,755	36,519	39,778
Operating weight*	kg	20 380	20 488	20 331	20 428	20 536	20 379	20 468	20 576	20 419
	lb	44,918	45,156	44,810	45,023	45,261	44,915	45,112	45,350	45,004

*Static tipping loads and operating weights shown are based on a global machine configuration with Michelin 23.5R25 XHA2 L3 Radial tires, full fluids, operator, standard counterweight, standard linkage, cold start, roading fenders, Product Link, open differential axles (front/rear), power train guard, secondary steering, and sound suppression.

**Measured 102 mm (4") behind tip of cutting edge with bucket hinge pin as pivot point in accordance with SAE J732C.

(§) Specifications and ratings conform to all applicable standards recommended by the Society of Automotive Engineers, including SAE Standard J732C governing loader ratings.

(ISO) Full compliance to ISO 14397-1 (2007) Sections 1 thru 6, which requires 2% verification between calculations and testing.

(Rigid Tire) Compliance to ISO 14397-1 (2007) Sections 1 thru 5.

NOTE: Bucket availability varies by region. Consult your local dealer for availability.

Bucket Type	Material Handling — Pin On						General Purpose — Fusion QC			
	Bolt-on Cutting Edges	Teeth & Segments	Teeth	Bolt-on Cutting Edges	Teeth & Segments	Teeth	Bolt-on Cutting Edges	Teeth & Segments	Teeth	
Edge Type										
Capacity — rated (§)	m ³ yd ³	3.60 4.71	3.60 4.71	3.40 4.45	3.80 4.97	3.80 4.97	3.60 4.71	2.70 3.53	2.70 3.53	2.50 3.27
Capacity — struck (§)	m ³ yd ³	3.15 4.12	3.15 4.12	2.95 3.86	3.28 4.29	3.28 4.29	3.11 4.07	2.30 3.01	2.30 3.01	2.11 2.76
Width (§)	mm ft/in	2927 9'7"	2994 9'9"	2994 9'9"	2927 9'7"	2994 9'9"	2994 9'9"	2927 9'7"	2994 9'9"	2994 9'9"
Dump clearance at maximum lift and 45° discharge (§)	mm ft/in	2946 9'8"	2821 9'3"	2821 9'3"	2910 9'6"	2785 9'1"	2785 9'1"	3153 10'4"	3037 9'11"	3037 9'11"
Reach at maximum lift and 45° discharge (§)	mm ft/in	1372 4'6"	1474 4'10"	1474 4'10"	1408 4'7"	1510 4'11"	1510 4'11"	1336 4'4"	1449 4'9"	1449 4'9"
Reach at level lift arm and bucket level (§)	mm ft/in	2914 9'6"	3075 10'1"	3075 10'1"	2965 9'8"	3126 10'3"	3126 10'3"	2720 8'11"	2881 9'5"	2881 9'5"
Digging depth (§)	mm in	88 3.5	88 3.5	58 2.3	88 3.5	88 3.5	58 2.3	88 3.5	88 3.5	58 2.3
Overall length	mm ft/in	8561 28'2"	8733 28'8"	8733 28'8"	8612 28'4"	8784 28'10"	8784 28'10"	8367 27'6"	8539 28'1"	8539 28'1"
Overall height with bucket at maximum lift	mm ft/in	5831 19'2"	5831 19'2"	5831 19'2"	5879 19'4"	5879 19'4"	5879 19'4"	5641 18'7"	5641 18'7"	5641 18'7"
Loader clearance circle with bucket at carry position (§)	mm ft/in	13 936 45'9"	14 108 46'4"	14 108 46'4"	13 967 45'10"	14 139 46'5"	14 139 46'5"	13 811 45'4"	13 982 45'11"	13 982 45'11"
Static tipping load, straight (ISO)*	kg lb	13 334 29,389	13 194 29,079	13 470 29,689	13 226 29,150	13 084 28,838	13 357 29,440	13 391 29,515	13 255 29,214	13 595 29,963
Static tipping load, straight (Rigid Tire)*	kg lb	14 069 31,009	13 927 30,697	14 210 31,320	13 962 30,774	13 820 30,459	14 098 31,074	14 124 31,131	13 987 30,827	14 339 31,604
Static tipping load, articulated (ISO)*	kg lb	11 432 25,196	11 291 24,887	11 551 25,458	11 329 24,970	11 188 24,659	11 443 25,222	11 470 25,281	11 333 24,979	11 653 25,684
Static tipping load, articulated (Rigid Tire)*	kg lb	12 188 26,864	12 047 26,552	12 311 27,135	12 088 26,642	11 945 26,327	12 206 26,902	12 225 26,944	12 087 26,640	12 419 27,371
Breakout force** (§)	kN lbf	157 35,483	156 35,247	170 38,308	151 34,128	150 33,891	163 36,751	185 41,637	184 41,401	202 45,487
Operating weight*	kg lb	20 512 45,208	20 620 45,446	20 463 45,100	20 566 45,327	20 674 45,565	20 517 45,219	20 726 45,680	20 834 45,918	20 677 45,572

*Static tipping loads and operating weights shown are based on a global machine configuration with Michelin 23.5R25 XHA2 L3 Radial tires, full fluids, operator, standard counterweight, standard linkage, cold start, roading fenders, Product Link, open differential axles (front/rear), power train guard, secondary steering, and sound suppression.

**Measured 102 mm (4") behind tip of cutting edge with bucket hinge pin as pivot point in accordance with SAE J732C.

(§) Specifications and ratings conform to all applicable standards recommended by the Society of Automotive Engineers, including SAE Standard J732C governing loader ratings.

(ISO) Full compliance to ISO 14397-1 (2007) Sections 1 thru 6, which requires 2% verification between calculations and testing.

(Rigid Tire) Compliance to ISO 14397-1 (2007) Sections 1 thru 5.

NOTE: Bucket availability varies by region. Consult your local dealer for availability.

Bucket Type		General Purpose — Fusion QC									
		Bolt-on Cutting Edges	Teeth & Segments	Teeth	Bolt-on Cutting Edges	Teeth & Segments	Teeth	Bolt-on Cutting Edges	Teeth & Segments	Teeth	
Edge Type											
	Capacity — rated (§)	m ³	2.90	2.90	2.70	3.10	3.10	2.90	3.30	3.30	3.10
		yd ³	3.79	3.79	3.53	4.05	4.05	3.79	4.32	4.32	4.05
Capacity — struck (§)		m ³	2.55	2.55	2.33	2.76	2.76	2.54	2.94	2.94	2.72
		yd ³	3.34	3.34	3.05	3.61	3.61	3.32	3.85	3.85	3.56
Width (§)		mm	2927	2994	2994	2927	2994	2994	2927	2994	2994
		ft/in	9'7"	9'9"	9'9"	9'7"	9'9"	9'9"	9'7"	9'9"	9'9"
Dump clearance at maximum lift and 45° discharge (§)		mm	3097	2980	2980	3053	2935	2935	3015	2896	2896
		ft/in	10'1"	9'9"	9'9"	10'0"	9'7"	9'7"	9'10"	9'6"	9'6"
Reach at maximum lift and 45° discharge (§)		mm	1374	1485	1485	1408	1519	1519	1437	1547	1547
		ft/in	4'6"	4'10"	4'10"	4'7"	4'11"	4'11"	4'8"	5'0"	5'0"
Reach at level lift arm and bucket level (§)		mm	2789	2950	2950	2846	3007	3007	2895	3056	3056
		ft/in	9'1"	9'8"	9'8"	9'4"	9'10"	9'10"	9'5"	10'0"	10'0"
Digging depth (§)		mm	88	88	58	88	88	58	88	88	58
		in	3.5	3.5	2.3	3.5	3.5	2.3	3.5	3.5	2.3
Overall length		mm	8436	8608	8608	8493	8665	8665	8542	8714	8714
		ft/in	27'9"	28'3"	28'3"	27'11"	28'6"	28'6"	28'1"	28'8"	28'8"
Overall height with bucket at maximum lift		mm	5714	5714	5714	5775	5775	5775	5821	5821	5821
		ft/in	18'9"	18'9"	18'9"	19'0"	19'0"	19'0"	19'2"	19'2"	19'2"
Loader clearance circle with bucket at carry position (§)		mm	13 852	14 024	14 024	13 887	14 060	14 060	13 917	14 090	14 090
		ft/in	45'6"	46'1"	46'1"	45'7"	46'2"	46'2"	45'8"	46'3"	46'3"
Static tipping load, straight (ISO)*		kg	13 270	13 132	13 468	13 152	13 013	13 348	13 056	12 916	13 250
		lb	29,247	28,943	29,685	28,988	28,682	29,421	28,776	28,467	29,203
Static tipping load, straight (Rigid Tire)*		kg	14 006	13 867	14 215	13 891	13 751	14 098	13 796	13 655	14 001
		lb	30,870	30,563	31,331	30,616	30,307	31,072	30,408	30,097	30,859
Static tipping load, articulated (ISO)*		kg	11 355	11 217	11 534	11 244	11 105	11 421	11 154	11 014	11 328
		lb	25,027	24,722	25,421	24,783	24,477	25,173	24,583	24,275	24,969
Static tipping load, articulated (Rigid Tire)*		kg	12 112	11 973	12 302	12 004	11 864	12 192	11 915	11 774	12 101
		lb	26,696	26,389	27,114	26,458	26,149	26,872	26,262	25,951	26,671
Breakout force** (§)		kN	174	173	190	166	165	180	160	159	173
		lbf	39,256	39,020	42,687	37,469	37,233	40,603	36,044	35,808	38,953
Operating weight*		kg	20 789	20 897	20 740	20 843	20 951	20 794	20 889	20 997	20 840
		lb	45,818	46,056	45,710	45,937	46,175	45,829	46,039	46,277	45,931

*Static tipping loads and operating weights shown are based on a global machine configuration with Michelin 23.5R25 XHA2 L3 Radial tires, full fluids, operator, standard counterweight, standard linkage, cold start, roading fenders, Product Link, open differential axles (front/rear), power train guard, secondary steering, and sound suppression.

**Measured 102 mm (4") behind tip of cutting edge with bucket hinge pin as pivot point in accordance with SAE J732C.

(§) Specifications and ratings conform to all applicable standards recommended by the Society of Automotive Engineers, including SAE Standard J732C governing loader ratings.

(ISO) Full compliance to ISO 14397-1 (2007) Sections 1 thru 6, which requires 2% verification between calculations and testing.

(Rigid Tire) Compliance to ISO 14397-1 (2007) Sections 1 thru 5.

NOTE: Bucket availability varies by region. Consult your local dealer for availability.

Bucket Type		General Purpose — Fusion QC									
		Bolt-on Cutting Edges	Teeth & Segments	Teeth	Bolt-on Cutting Edges	Teeth & Segments	Teeth	Bolt-on Cutting Edges	Teeth & Segments	Teeth	
Edge Type	Capacity — rated (§)	m ³	3.40	3.40	3.20	3.60	3.60	3.40	3.80	3.80	3.60
		yd ³	4.45	4.45	4.19	4.71	4.71	4.45	4.97	4.97	4.71
Capacity — struck (§)		m ³	3.04	3.04	2.81	3.18	3.18	2.94	3.36	3.36	3.12
		yd ³	3.98	3.98	3.68	4.16	4.16	3.85	4.39	4.39	4.08
Width (§)		mm	2927	2994	2994	2927	2994	2994	2927	2994	2994
		ft/in	9'7"	9'9"	9'9"	9'7"	9'9"	9'9"	9'7"	9'9"	9'9"
Dump clearance at maximum lift and 45° discharge (§)		mm	2996	2877	2877	2970	2850	2850	2935	2815	2815
		ft/in	9'9"	9'5"	9'5"	9'8"	9'4"	9'4"	9'7"	9'2"	9'2"
Reach at maximum lift and 45° discharge (§)		mm	1451	1561	1561	1473	1582	1582	1502	1611	1611
		ft/in	4'9"	5'1"	5'1"	4'10"	5'2"	5'2"	4'11"	5'3"	5'3"
Reach at level lift arm and bucket level (§)		mm	2919	3080	3080	2954	3115	3115	3000	3161	3161
		ft/in	9'6"	10'1"	10'1"	9'8"	10'2"	10'2"	9'10"	10'4"	10'4"
Digging depth (§)		mm	88	88	58	88	88	58	88	88	58
		in	3.5	3.5	2.3	3.5	3.5	2.3	3.5	3.5	2.3
Overall length		mm	8566	8738	8738	8601	8773	8773	8647	8819	8819
		ft/in	28'2"	28'9"	28'9"	28'3"	28'10"	28'10"	28'5"	29'0"	29'0"
Overall height with bucket at maximum lift		mm	5847	5847	5847	5881	5881	5928	5928	5928	5928
		ft/in	19'3"	19'3"	19'3"	19'4"	19'4"	19'4"	19'6"	19'6"	19'6"
Loader clearance circle with bucket at carry position (§)		mm	13 932	14 105	14 105	13 953	14 127	14 127	13 982	14 157	14 157
		ft/in	45'9"	46'4"	46'4"	45'10"	46'5"	46'5"	45'11"	46'6"	46'6"
Static tipping load, straight (ISO)*		kg	13 011	12 871	13 204	12 941	12 800	13 132	12 849	12 708	13 039
		lb	28,677	28,368	29,102	28,524	28,213	28,945	28,321	28,008	28,738
Static tipping load, straight (Rigid Tire)*		kg	13 753	13 611	13 956	13 684	13 542	13 886	13 594	13 451	13 794
		lb	30,312	29,999	30,759	30,161	29,847	30,605	29,962	29,646	30,402
Static tipping load, articulated (ISO)*		kg	11 111	10 971	11 285	11 045	10 904	11 218	10 959	10 817	11 129
		lb	24,490	24,180	24,872	24,344	24,034	24,724	24,153	23,841	24,530
Static tipping load, articulated (Rigid Tire)*		kg	11 874	11 732	12 058	11 810	11 667	11 992	11 724	11 581	11 905
		lb	26,171	25,859	26,577	26,029	25,715	26,431	25,841	25,526	26,240
Breakout force** (§)		kN	157	156	169	153	152	165	148	147	159
		lbf	35,379	35,143	38,186	34,449	34,213	37,117	33,289	33,053	35,789
Operating weight*		kg	20 913	21 021	20 864	20 947	21 055	20 898	20 992	21 100	20 943
		lb	46,091	46,329	45,983	46,166	46,404	46,058	46,265	46,503	46,157

*Static tipping loads and operating weights shown are based on a global machine configuration with Michelin 23.5R25 XHA2 L3 Radial tires, full fluids, operator, standard counterweight, standard linkage, cold start, roading fenders, Product Link, open differential axles (front/rear), power train guard, secondary steering, and sound suppression.

**Measured 102 mm (4") behind tip of cutting edge with bucket hinge pin as pivot point in accordance with SAE J732C.

(§) Specifications and ratings conform to all applicable standards recommended by the Society of Automotive Engineers, including SAE Standard J732C governing loader ratings.

(ISO) Full compliance to ISO 14397-1 (2007) Sections 1 thru 6, which requires 2% verification between calculations and testing.

(Rigid Tire) Compliance to ISO 14397-1 (2007) Sections 1 thru 5.

NOTE: Bucket availability varies by region. Consult your local dealer for availability.

Bucket Type		Material Handling — Fusion QC								
		Bolt-on Cutting Edges	Teeth & Segments	Teeth	Bolt-on Cutting Edges	Teeth & Segments	Teeth	Bolt-on Cutting Edges	Teeth & Segments	Teeth
Edge Type										
	Capacity — rated (§)	m³ yd³	2.70 3.53	2.70 3.53	2.50 3.27	2.90 3.79	2.90 3.79	2.70 3.53	3.10 4.05	3.10 4.05
Capacity — struck (§)	m³	2.20	2.20	2.00	2.40	2.40	2.20	2.61	2.61	2.44
	yd³	2.88	2.88	2.62	3.14	3.14	2.88	3.41	3.41	3.19
Width (§)	mm	2927	2994	2994	2927	2994	2994	2927	2994	2994
	ft/in	9'7"	9'9"	9'9"	9'7"	9'9"	9'9"	9'7"	9'9"	9'9"
Dump clearance at maximum lift and 45° discharge (§)	mm	3070	2944	2944	3027	2902	2902	2996	2870	2870
	ft/in	10'0"	9'7"	9'7"	9'11"	9'6"	9'6"	9'9"	9'5"	9'5"
Reach at maximum lift and 45° discharge (§)	mm	1248	1350	1350	1290	1393	1393	1322	1424	1424
	ft/in	4'1"	4'5"	4'5"	4'2"	4'6"	4'6"	4'4"	4'8"	4'8"
Reach at level lift arm and bucket level (§)	mm	2739	2900	2900	2799	2960	2960	2844	3005	3005
	ft/in	8'11"	9'6"	9'6"	9'2"	9'8"	9'8"	9'3"	9'10"	9'10"
Digging depth (§)	mm	88	88	58	88	88	58	88	88	58
	in	3.5	3.5	2.3	3.5	3.5	2.3	3.5	3.5	2.3
Overall length	mm	8386	8558	8558	8446	8618	8618	8491	8663	8663
	ft/in	27'7"	28'1"	28'1"	27'9"	28'4"	28'4"	27'11"	28'6"	28'6"
Overall height with bucket at maximum lift	mm	5634	5634	5634	5697	5697	5697	5734	5734	5734
	ft/in	18'6"	18'6"	18'6"	18'9"	18'9"	18'9"	18'10"	18'10"	18'10"
Loader clearance circle with bucket at carry position (§)	mm	13 822	13 994	13 994	13 858	14 030	14 030	13 886	14 058	14 058
	ft/in	45'5"	45'11"	45'11"	45'6"	46'1"	46'1"	45'7"	46'2"	46'2"
Static tipping load, straight (ISO)*	kg	13 244	13 108	13 434	13 132	12 995	13 317	13 035	12 897	13 219
	lb	29,190	28,891	29,609	28,943	28,641	29,352	28,729	28,426	29,136
Static tipping load, straight (Rigid Tire)*	kg	13 961	13 824	14 160	13 851	13 713	14 046	13 756	13 617	13 949
	lb	30,771	30,470	31,210	30,529	30,225	30,957	30,318	30,012	30,744
Static tipping load, articulated (ISO)*	kg	11 342	11 207	11 514	11 237	11 100	11 405	11 145	11 008	11 312
	lb	24,999	24,700	25,378	24,767	24,465	25,137	24,565	24,261	24,933
Static tipping load, articulated (Rigid Tire)*	kg	12 082	11 945	12 262	11 978	11 840	12 155	11 888	11 749	12 064
	lb	26,628	26,327	27,026	26,401	26,097	26,790	26,202	25,896	26,589
Breakout force** (§)	kN	182	181	198	173	172	188	166	165	180
	lbf	40,950	40,714	44,677	38,931	38,695	42,307	37,518	37,282	40,662
Operating weight*	kg	20 732	20 840	20 683	20 784	20 892	20 735	20 833	20 941	20 784
	lb	45,693	45,931	45,585	45,807	46,045	45,699	45,915	46,153	45,807

*Static tipping loads and operating weights shown are based on a global machine configuration with Michelin 23.5R25 XHA2 L3 Radial tires, full fluids, operator, standard counterweight, standard linkage, cold start, roading fenders, Product Link, open differential axles (front/rear), power train guard, secondary steering, and sound suppression.

**Measured 102 mm (4") behind tip of cutting edge with bucket hinge pin as pivot point in accordance with SAE J732C.

(§) Specifications and ratings conform to all applicable standards recommended by the Society of Automotive Engineers, including SAE Standard J732C governing loader ratings.

(ISO) Full compliance to ISO 14397-1 (2007) Sections 1 thru 6, which requires 2% verification between calculations and testing.

(Rigid Tire) Compliance to ISO 14397-1 (2007) Sections 1 thru 5.

NOTE: Bucket availability varies by region. Consult your local dealer for availability.

Bucket Type	Material Handling — Fusion QC						
	Edge Type	Bolt-on Cutting Edges	Teeth & Segments	Teeth	Bolt-on Cutting Edges	Teeth & Segments	Teeth
Capacity — rated (§)	m ³	3.30	3.30	3.10	3.40	3.40	3.20
	yd ³	4.32	4.32	4.05	4.45	4.45	4.19
Capacity — struck (§)	m ³	2.78	2.78	2.61	2.92	2.92	2.74
	yd ³	3.64	3.64	3.41	3.82	3.82	3.58
Width (§)	mm	2927	2994	2994	2927	2994	2994
	ft/in	9'7"	9'9"	9'9"	9'7"	9'9"	9'9"
Dump clearance at maximum lift and 45° discharge (§)	mm	2964	2838	2838	2936	2810	2810
	ft/in	9'8"	9'3"	9'3"	9'7"	9'2"	9'2"
Reach at maximum lift and 45° discharge (§)	mm	1354	1456	1456	1382	1485	1485
	ft/in	4'5"	4'9"	4'9"	4'6"	4'10"	4'10"
Reach at level lift arm and bucket level (§)	mm	2889	3050	3050	2929	3090	3090
	ft/in	9'5"	10'0"	10'0"	9'7"	10'1"	10'1"
Digging depth (§)	mm	88	88	58	88	88	58
	in	3.5	3.5	2.3	3.5	3.5	2.3
Overall length	mm	8536	8708	8708	8576	8748	8748
	ft/in	28'1"	28'7"	28'7"	28'2"	28'9"	28'9"
Overall height with bucket at maximum lift	mm	5778	5778	5778	5817	5817	5817
	ft/in	19'0"	19'0"	19'0"	19'1"	19'1"	19'1"
Loader clearance circle with bucket at carry position (§)	mm	13 913	14 086	14 086	13 938	14 112	14 112
	ft/in	45'8"	46'3"	46'3"	45'9"	46'4"	46'4"
Static tipping load, straight (ISO)*	kg	12 943	12 804	13 130	12 867	12 728	13 050
	lb	28,526	28,221	28,939	28,359	28,053	28,763
Static tipping load, straight (Rigid Tire)*	kg	13 665	13 525	13 862	13 591	13 451	13 783
	lb	30,118	29,810	30,552	29,955	29,646	30,378
Static tipping load, articulated (ISO)*	kg	11 059	10 920	11 228	10 987	10 848	11 153
	lb	24,374	24,069	24,747	24,216	23,909	24,581
Static tipping load, articulated (Rigid Tire)*	kg	11 803	11 663	11 981	11 733	11 593	11 907
	lb	26,014	25,706	26,407	25,860	25,551	26,244
Breakout force** (§)	kN	161	160	174	156	155	168
	lbf	36,201	35,965	39,135	35,098	34,862	37,864
Operating weight*	kg	20 877	20 985	20 828	20 915	21 023	20 866
	lb	46,012	46,250	45,904	46,096	46,334	45,988

*Static tipping loads and operating weights shown are based on a global machine configuration with Michelin 23.5R25 XHA2 L3 Radial tires, full fluids, operator, standard counterweight, standard linkage, cold start, roading fenders, Product Link, open differential axles (front/rear), power train guard, secondary steering, and sound suppression.

**Measured 102 mm (4") behind tip of cutting edge with bucket hinge pin as pivot point in accordance with SAE J732C.

(§) Specifications and ratings conform to all applicable standards recommended by the Society of Automotive Engineers, including SAE Standard J732C governing loader ratings.

(ISO) Full compliance to ISO 14397-1 (2007) Sections 1 thru 6, which requires 2% verification between calculations and testing.

(Rigid Tire) Compliance to ISO 14397-1 (2007) Sections 1 thru 5.

NOTE: Bucket availability varies by region. Consult your local dealer for availability.

Bucket Type	Material Handling — Fusion QC						High Lift Change in Specs
	Bolt-on Cutting Edges	Teeth & Segments	Teeth	Bolt-on Cutting Edges	Teeth & Segments	Teeth	
Edge Type							
Capacity — rated (§)	m ³	3.60	3.60	3.40	3.80	3.80	3.60
	yd ³	4.71	4.71	4.45	4.97	4.97	4.71
Capacity — struck (§)	m ³	3.10	3.10	2.90	3.28	3.28	3.11
	yd ³	4.05	4.05	3.79	4.29	4.29	4.07
Width (§)	mm	2927	2994	2994	2927	2994	2994
	ft/in	9'7"	9'9"	9'9"	9'7"	9'9"	9'9"
Dump clearance at maximum lift and 45° discharge (§)	mm	2904	2778	2778	2868	2742	2742
	ft/in	9'6"	9'1"	9'1"	9'4"	8'11"	8'11"
Reach at maximum lift and 45° discharge (§)	mm	1414	1516	1516	1450	1552	1552
	ft/in	4'7"	4'11"	4'11"	4'9"	5'1"	5'1"
Reach at level lift arm and bucket level (§)	mm	2974	3135	3135	3025	3186	3186
	ft/in	9'9"	10'3"	10'3"	9'11"	10'5"	10'5"
Digging depth (§)	mm	88	88	58	88	88	58
	in	3.5	3.5	2.3	3.5	3.5	2.3
Overall length	mm	8621	8793	8793	8672	8844	8844
	ft/in	28'4"	28'11"	28'11"	28'6"	29'1"	29'1"
Overall height with bucket at maximum lift	mm	5860	5860	5860	5913	5913	5913
	ft/in	19'3"	19'3"	19'3"	19'5"	19'5"	19'5"
Loader clearance circle with bucket at carry position (§)	mm	13 966	14 140	14 140	13 998	14 173	14 173
	ft/in	45'10"	46'5"	46'5"	46'0"	46'6"	46'6"
Static tipping load, straight (ISO)*	kg	12 779	12 639	12 962	12 674	12 533	12 856
	lb	28,166	27,857	28,568	27,935	27,624	28,335
Static tipping load, straight (Rigid Tire)*	kg	13 504	13 363	13 696	13 401	13 259	13 592
	lb	29,764	29,453	30,187	29,537	29,223	29,957
Static tipping load, articulated (ISO)*	kg	10 905	10 765	11 070	10 805	10 665	10 970
	lb	24,034	23,726	24,398	23,816	23,505	24,178
Static tipping load, articulated (Rigid Tire)*	kg	11 652	11 511	11 826	11 554	11 412	11 728
	lb	25,681	25,370	26,065	25,466	25,153	25,848
Breakout force** (§)	kN	151	149	162	145	144	156
	lbf	33,932	33,696	36,525	32,677	32,440	35,091
Operating weight*	kg	20 955	21 063	20 906	21 009	21 117	20 960
	lb	46,184	46,422	46,076	46,303	46,541	46,195

*Static tipping loads and operating weights shown are based on a global machine configuration with Michelin 23.5R25 XHA2 L3 Radial tires, full fluids, operator, standard counterweight, standard linkage, cold start, roading fenders, Product Link, open differential axles (front/rear), power train guard, secondary steering, and sound suppression.

**Measured 102 mm (4") behind tip of cutting edge with bucket hinge pin as pivot point in accordance with SAE J732C.

(§) Specifications and ratings conform to all applicable standards recommended by the Society of Automotive Engineers, including SAE Standard J732C governing loader ratings.

(ISO) Full compliance to ISO 14397-1 (2007) Sections 1 thru 6, which requires 2% verification between calculations and testing.

(Rigid Tire) Compliance to ISO 14397-1 (2007) Sections 1 thru 5.

NOTE: Bucket availability varies by region. Consult your local dealer for availability.

Bucket Type		General Purpose — Pin On									
		Bolt-on Cutting Edges	Teeth & Segments	Teeth	Bolt-on Cutting Edges	Teeth & Segments	Teeth	Bolt-on Cutting Edges	Teeth & Segments	Teeth	
Edge Type											
	Capacity — rated (§)	m ³	3.80	3.80	3.60	4.00	4.00	3.80	4.20	4.20	4.00
		yd ³	4.97	4.97	4.71	5.23	5.23	4.97	5.49	5.49	5.23
Capacity — struck (§)		m ³	3.24	3.24	3.09	3.50	3.50	3.34	3.80	3.80	3.60
		yd ³	4.24	4.24	4.04	4.58	4.58	4.37	4.97	4.97	4.71
Width (§)		mm	3220	3271	3271	3220	3271	3271	3220	3271	3271
		ft/in	10'6"	10'8"	10'8"	10'6"	10'8"	10'8"	10'6"	10'8"	10'8"
Dump clearance at maximum lift and 45° discharge (§)		mm	3067	2915	2915	3058	2905	2905	2991	2837	2837
		ft/in	10'0"	9'6"	9'6"	10'0"	9'6"	9'6"	9'9"	9'3"	9'3"
Reach at maximum lift and 45° discharge (§)		mm	1327	1467	1467	1334	1473	1473	1388	1525	1525
		ft/in	4'4"	4'9"	4'9"	4'4"	4'10"	4'10"	4'6"	5'0"	5'0"
Reach at level lift arm and bucket level (§)		mm	2739	2943	2943	2750	2955	2955	2838	3043	3043
		ft/in	8'11"	9'7"	9'7"	9'0"	9'8"	9'8"	9'3"	9'11"	9'11"
Digging depth (§)		mm	124	124	94	124	124	94	124	124	94
		in	4.9	4.9	3.7	4.9	4.9	3.7	4.9	4.9	3.7
Overall length		mm	8592	8817	8817	8604	8829	8829	8691	8916	8916
		ft/in	28'3"	29'0"	29'0"	28'3"	29'0"	29'0"	28'7"	29'4"	29'4"
Overall height with bucket at maximum lift		mm	5788	5788	5788	5902	5902	5902	5902	5902	5902
		ft/in	19'0"	19'0"	19'0"	19'5"	19'5"	19'5"	19'5"	19'5"	19'5"
Loader clearance circle with bucket at carry position (§)		mm	14 727	14 899	14 899	14 733	14 905	14 905	14 778	14 951	14 951
		ft/in	48'4"	48'11"	48'11"	48'5"	48'11"	48'11"	48'6"	49'1"	49'1"
Static tipping load, straight (ISO)*		kg	16 852	16 671	16 870	16 833	16 652	16 885	16 635	16 453	16 693
		lb	37,142	36,743	37,182	37,101	36,701	37,215	36,664	36,262	36,792
Static tipping load, straight (Rigid Tire)*		kg	18 071	17 886	18 074	18 062	17 877	18 113	17 855	17 669	17 913
		lb	39,829	39,422	39,835	39,809	39,401	39,922	39,353	38,943	39,480
Static tipping load, articulated (ISO)*		kg	14 843	14 661	14 851	14 821	14 638	14 856	14 636	14 452	14 677
		lb	32,715	32,312	32,733	32,666	32,262	32,743	32,259	31,853	32,349
Static tipping load, articulated (Rigid Tire)*		kg	16 034	15 849	16 028	16 021	15 836	16 056	15 828	15 642	15 869
		lb	35,339	34,932	35,326	35,311	34,903	35,388	34,886	34,476	34,977
Breakout force** (§)		kN	187	185	199	185	183	197	173	171	184
		lbf	42,151	41,781	44,901	41,695	41,326	44,390	38,984	38,618	41,343
Operating weight*		kg	24 081	24 218	24 055	24 133	24 270	24 107	24 189	24 326	24 163
		lb	53,073	53,377	53,017	53,188	53,492	53,132	53,311	53,615	53,255

*Static tipping loads and operating weights shown are based on a machine configuration with Michelin 26.5R25 XHA2 L3 Radial tires, full fluids, operator, standard counterweight, cold start, roading fenders, Product Link, open differential axles (front/rear), power train guard, secondary steering, and sound suppression.

**Measured 102 mm (4") behind tip of cutting edge with bucket hinge pin as pivot point in accordance with SAE J732C.

(§) Specifications and ratings conform to all applicable standards recommended by the Society of Automotive Engineers, including SAE Standard J732C governing loader ratings.

(ISO) Full compliance to ISO 14397-1 (2007) Sections 1 thru 6, which requires 2% verification between calculations and testing.

(Rigid Tire) Compliance to ISO 14397-1 (2007) Sections 1 thru 5.

NOTE: Bucket availability varies by region. Consult your local dealer for availability.

Bucket Type	General Purpose — Pin On			General Purpose — Fusion QC						
	Edge Type	Bolt-on Cutting Edges	Teeth & Segments	Teeth	Bolt-on Cutting Edges	Teeth & Segments	Teeth	Bolt-on Cutting Edges	Teeth & Segments	Teeth
Capacity — rated (§)	m ³	4.60	4.60	4.40	3.80	3.80	3.60	4.20	4.20	4.00
	yd ³	6.02	6.02	5.75	4.97	4.97	4.71	5.49	5.49	5.23
Capacity — struck (§)	m ³	4.05	4.05	3.90	3.24	3.24	3.09	3.80	3.80	3.60
	yd ³	5.30	5.30	5.10	4.24	4.24	4.04	4.97	4.97	4.71
Width (§)	mm	3220	3271	3271	3220	3271	3271	3220	3271	3271
	ft/in	10'6"	10'8"	10'8"	10'6"	10'8"	10'8"	10'6"	10'8"	10'8"
Dump clearance at maximum lift and 45° discharge (§)	mm	2977	2823	2823	3038	2886	2886	2960	2806	2806
	ft/in	9'9"	9'3"	9'3"	9'11"	9'5"	9'5"	9'8"	9'2"	9'2"
Reach at maximum lift and 45° discharge (§)	mm	1400	1537	1537	1362	1501	1501	1433	1571	1571
	ft/in	4'7"	5'0"	5'0"	4'5"	4'11"	4'11"	4'8"	5'1"	5'1"
Reach at level lift arm and bucket level (§)	mm	2857	3062	3062	2783	2988	2988	2893	3097	3097
	ft/in	9'4"	10'0"	10'0"	9'1"	9'9"	9'9"	9'5"	10'1"	10'1"
Digging depth (§)	mm	124	124	94	124	124	94	116	116	86
	in	4.9	4.9	3.7	4.9	4.9	3.7	4.5	4.5	3.4
Overall length	mm	8710	8935	8935	8637	8862	8862	8739	8965	8965
	ft/in	28'7"	29'4"	29'4"	28'5"	29'1"	29'1"	28'9"	29'5"	29'5"
Overall height with bucket at maximum lift	mm	5874	5874	5874	5803	5803	5803	5960	5960	5960
	ft/in	19'4"	19'4"	19'4"	19'1"	19'1"	19'1"	19'7"	19'7"	19'7"
Loader clearance circle with bucket at carry position (§)	mm	14 787	14 961	14 961	14 743	14 917	14 917	14 794	14 970	14 970
	ft/in	48'7"	49'1"	49'1"	48'5"	49'0"	49'0"	48'7"	49'2"	49'2"
Static tipping load, straight (ISO)*	kg	16 631	16 447	16 792	16 279	16 099	16 440	16 015	15 834	16 167
	lb	36,655	36,249	37,010	35,880	35,483	36,233	35,297	34,898	35,634
Static tipping load, straight (Rigid Tire)*	kg	17 875	17 687	18 047	17 471	17 287	17 643	17 204	17 020	17 368
	lb	39,397	38,983	39,777	38,506	38,101	38,885	37,918	37,512	38,280
Static tipping load, articulated (ISO)*	kg	14 622	14 436	14 771	14 292	14 111	14 438	14 047	13 865	14 186
	lb	32,227	31,817	32,556	31,501	31,100	31,821	30,961	30,558	31,266
Static tipping load, articulated (Rigid Tire)*	kg	15 837	15 649	15 997	15 460	15 276	15 616	15 214	15 029	15 363
	lb	34,906	34,492	35,257	34,074	33,670	34,418	33,531	33,125	33,860
Breakout force** (§)	kN	170	168	180	180	179	192	166	164	176
	lbf	38,277	37,912	40,561	40,632	40,264	43,192	37,382	37,023	39,561
Operating weight*	kg	24 229	24 366	24 203	24 498	24 636	24 472	24 561	24 699	24 536
	lb	53,399	53,703	53,343	53,992	54,296	53,936	54,132	54,436	54,076

*Static tipping loads and operating weights shown are based on a machine configuration with Michelin 26.5R25 XHA2 L3 Radial tires, full fluids, operator, standard counterweight, cold start, roading fenders, Product Link, open differential axles (front/rear), power train guard, secondary steering, and sound suppression.

**Measured 102 mm (4") behind tip of cutting edge with bucket hinge pin as pivot point in accordance with SAE J732C.

(§) Specifications and ratings conform to all applicable standards recommended by the Society of Automotive Engineers, including SAE Standard J732C governing loader ratings.

(ISO) Full compliance to ISO 14397-1 (2007) Sections 1 thru 6, which requires 2% verification between calculations and testing.

(Rigid Tire) Compliance to ISO 14397-1 (2007) Sections 1 thru 5.

NOTE: Bucket availability varies by region. Consult your local dealer for availability.

Bucket Type	General Purpose — Fusion QC			Material Handling — Pin On		
	Bolt-on Cutting Edges	Teeth & Segments	Teeth	Bolt-on Cutting Edges	Teeth & Segments	Teeth
Edge Type						
Capacity — rated (§)	m ³	4.60	4.60	4.40	4.20	4.00
	yd ³	6.02	6.02	5.75	5.49	5.23
Capacity — struck (§)	m ³	4.05	4.05	3.90	3.60	3.45
	yd ³	5.30	5.30	5.10	4.71	4.51
Width (§)	mm	3220	3271	3271	3220	3271
	ft/in	10'6"	10'8"	10'8"	10'6"	10'8"
Dump clearance at maximum lift and 45° discharge (§)	mm	2947	2793	2793	2967	2804
	ft/in	9'8"	9'1"	9'1"	9'8"	9'2"
Reach at maximum lift and 45° discharge (§)	mm	1436	1573	1573	1263	1390
	ft/in	4'8"	5'1"	5'1"	4'1"	4'6"
Reach at level lift arm and bucket level (§)	mm	2903	3108	3108	2784	2988
	ft/in	9'6"	10'2"	10'2"	9'1"	9'9"
Digging depth (§)	mm	123	123	93	124	124
	in	4.8	4.8	3.6	4.9	4.9
Overall length	mm	8755	8980	8980	8637	8862
	ft/in	28'9"	29'6"	29'6"	28'5"	29'1"
Overall height with bucket at maximum lift	mm	6038	6038	6038	5874	5874
	ft/in	19'10"	19'10"	19'10"	19'4"	19'4"
Loader clearance circle with bucket at carry position (§)	mm	14 804	14 981	14 981	14 750	14 922
	ft/in	48'7"	49'2"	49'2"	48'5"	49'0"
Static tipping load, straight (ISO)*	kg	16 131	15 947	16 277	16 598	16 417
	lb	35,553	35,148	35,875	36,582	36,185
Static tipping load, straight (Rigid Tire)*	kg	17 364	17 176	17 523	17 794	17 610
	lb	38,271	37,857	38,622	39,219	38,814
Static tipping load, articulated (ISO)*	kg	14 136	13 950	14 268	14 612	14 430
	lb	31,156	30,747	31,448	32,205	31,804
Static tipping load, articulated (Rigid Tire)*	kg	15 344	15 156	15 489	15 782	15 598
	lb	33,819	33,405	34,138	34,784	34,379
Breakout force** (§)	kN	164	163	174	180	179
	lbf	37,007	36,644	39,144	40,629	40,261
Operating weight*	kg	24 675	24 813	24 650	24 143	24 280
	lb	54,383	54,687	54,328	53,210	53,514

*Static tipping loads and operating weights shown are based on a machine configuration with Michelin 26.5R25 XHA2 L3 Radial tires, full fluids, operator, standard counterweight, cold start, roading fenders, Product Link, open differential axles (front/rear), power train guard, secondary steering, and sound suppression.

**Measured 102 mm (4") behind tip of cutting edge with bucket hinge pin as pivot point in accordance with SAE J732C.

(§) Specifications and ratings conform to all applicable standards recommended by the Society of Automotive Engineers, including SAE Standard J732C governing loader ratings.

(ISO) Full compliance to ISO 14397-1 (2007) Sections 1 thru 6, which requires 2% verification between calculations and testing.

(Rigid Tire) Compliance to ISO 14397-1 (2007) Sections 1 thru 5.

NOTE: Bucket availability varies by region. Consult your local dealer for availability.

Bucket Type	Rock – Pin On***			Coal – Pin On	Coal – Fusion QC	High Lift Change in Specs	
	Edge Type	Bolt-on Cutting Edges	Teeth & Segments	Teeth	Bolt-on Cutting Edges		Bolt-on Cutting Edges
Capacity – rated (\$)	m ³	3.40	3.40	3.20	7.10	7.10	–
	yd ³	4.45	4.45	4.19	9.29	9.29	–
Capacity – struck (\$)	m ³	2.90	2.90	2.70	6.20	6.20	–
	yd ³	3.79	3.79	3.53	8.11	8.11	–
Width (\$)	mm	3252	3252	3252	3447	3447	–
	ft/in	10'8"	10'8"	10'8"	11'3"	11'3"	–
Dump clearance at maximum lift and 45° discharge (\$)	mm	3124	3026	3026	2625	2597	558
	ft/in	10'2"	9'11"	9'11"	8'7"	8'6"	1'9"
Reach at maximum lift and 45° discharge (\$)	mm	1454	1576	1576	1583	1630	0
	ft/in	4'9"	5'2"	5'2"	5'2"	5'4"	0"
Reach at level lift arm and bucket level (\$)	mm	2818	2974	2974	3252	3305	404
	ft/in	9'2"	9'9"	9'9"	10'8"	10'10"	1'3"
Digging depth (\$)	mm	68	68	25	140	126	–25
	in	2.7	2.7	0.9	5.5	4.9	–1.0
Overall length	mm	8656	8817	8817	9117	9160	788
	ft/in	28'5"	29'0"	29'0"	29'11"	30'1"	2'7"
Overall height with bucket at maximum lift	mm	5845	5845	5845	6071	6311	559
	ft/in	19'3"	19'3"	19'3"	19'11"	20'9"	1'10"
Loader clearance circle with bucket at carry position (\$)	mm	14 813	14 901	14 901	15 214	15 232	481
	ft/in	48'8"	48'11"	48'11"	49'11"	50'0"	1'7"
Static tipping load, straight (ISO)*	kg	17 057	16 988	17 358	15 930	15 134	170
	lb	37,594	37,441	38,257	35,111	33,357	376
Static tipping load, straight (Rigid Tire)*	kg	18 293	18 222	18 604	17 192	16 375	115
	lb	40,318	40,162	41,003	37,891	36,091	254
Static tipping load, articulated (ISO)*	kg	15 004	14 934	15 298	13 955	13 180	–11
	lb	33,068	32,914	33,717	30,757	29,048	–26
Static tipping load, articulated (Rigid Tire)*	kg	16 213	16 142	16 515	15 189	14 399	–54
	lb	35,734	35,578	36,400	33,478	31,736	–120
Breakout force** (\$)	kN	186	185	193	129	124	–14
	lbf	41,828	41,704	43,564	29,095	27,969	–3167
Operating weight*	kg	25 011	25 063	24 832	24 496	25 130	1726
	lb	55,125	55,239	54,730	53,989	55,387	3803

*Static tipping loads and operating weights shown are based on a machine configuration with Michelin 26.5R25 XHA2 L3 Radial tires, full fluids, operator, standard counterweight, cold start, roading fenders, Product Link, open differential axles (front/rear), power train guard, secondary steering, and sound suppression.

**Measured 102 mm (4") behind tip of cutting edge with bucket hinge pin as pivot point in accordance with SAE J732C.

***Rock bucket specifications are given on Michelin 26.5R25 XLDD2 L5 Radial tires.

(\$)

Specifications and ratings conform to all applicable standards recommended by the Society of Automotive Engineers, including SAE Standard J732C governing loader ratings.

(ISO) Full compliance to ISO 14397-1 (2007) Sections 1 thru 6, which requires 2% verification between calculations and testing.

(Rigid Tire) Compliance to ISO 14397-1 (2007) Sections 1 thru 5.

NOTE: Bucket availability varies by region. Consult your local dealer for availability.

Bucket Type	General Purpose — Pin On									
		Bolt-on Cutting Edges	Teeth & Segments	Teeth	Bolt-on Cutting Edges	Teeth & Segments	Teeth	Bolt-on Cutting Edges	Teeth & Segments	Teeth
Edge Type										
Capacity — rated (§)	m ³	4.20	4.20	4.00	4.40	4.40	4.20	4.60	4.60	4.40
	yd ³	5.49	5.49	5.23	5.75	5.75	5.49	6.02	6.02	5.75
Capacity — struck (§)	m ³	3.70	3.70	3.50	3.80	3.80	3.60	4.00	4.00	3.80
	yd ³	4.84	4.84	4.58	4.97	4.97	4.71	5.23	5.23	4.97
Width (§)	mm	3220	3271	3271	3220	3271	3271	3220	3271	3271
	ft/in	10'6"	10'8"	10'8"	10'6"	10'8"	10'8"	10'6"	10'8"	10'8"
Dump clearance at maximum lift and 45° discharge (§)	mm	3225	3071	3071	3229	3076	3076	3187	3033	3033
	ft/in	10'6"	10'0"	10'0"	10'7"	10'1"	10'1"	10'5"	9'11"	9'11"
Reach at maximum lift and 45° discharge (§)	mm	1332	1470	1470	1327	1465	1465	1363	1500	1500
	ft/in	4'4"	4'9"	4'9"	4'4"	4'9"	4'9"	4'5"	4'11"	4'11"
Reach at level lift arm and bucket level (§)	mm	2955	3160	3160	2948	3153	3153	3004	3209	3209
	ft/in	9'8"	10'4"	10'4"	9'8"	10'4"	10'4"	9'10"	10'6"	10'6"
Digging depth (§)	mm	103	103	73	103	103	73	103	103	73
	in	4.0	4.0	2.8	4.0	4.0	2.8	4.0	4.0	2.8
Overall length	mm	9129	9353	9353	9122	9346	9346	9178	9402	9402
	ft/in	30'0"	30'9"	30'9"	30'0"	30'8"	30'8"	30'2"	30'11"	30'11"
Overall height with bucket at maximum lift	mm	5937	5937	5937	6230	6230	6230	6195	6195	6195
	ft/in	19'6"	19'6"	19'6"	20'6"	20'6"	20'6"	20'4"	20'4"	20'4"
Loader clearance circle with bucket at carry position (§)	mm	14 925	15 104	15 104	14 921	15 100	15 100	14 951	15 132	15 132
	ft/in	49'0"	49'7"	49'7"	49'0"	49'7"	49'7"	49'1"	49'8"	49'8"
Static tipping load, straight (ISO)*	kg	18 770	18 589	18 840	18 817	18 636	18 885	18 658	18 476	18 733
	lb	41,371	40,971	41,523	41,474	41,074	41,622	41,124	40,722	41,288
Static tipping load, straight (Rigid Tire)*	kg	20 088	19 903	20 157	20 147	19 962	20 215	19 985	19 799	20 059
	lb	44,274	43,866	44,427	44,405	43,996	44,554	44,048	43,638	44,210
Static tipping load, articulated (ISO)*	kg	16 396	16 213	16 447	16 437	16 253	16 485	16 289	16 104	16 343
	lb	36,138	35,734	36,251	36,227	35,822	36,334	35,901	35,494	36,021
Static tipping load, articulated (Rigid Tire)*	kg	17 706	17 521	17 757	17 758	17 573	17 807	17 608	17 422	17 662
	lb	39,024	38,616	39,138	39,140	38,731	39,248	38,808	38,398	38,927
Breakout force** (§)	kN	210	208	223	211	209	224	202	201	214
	lbf	47,189	46,880	50,138	47,419	47,109	50,397	45,482	45,173	48,227
Operating weight*	kg	26 223	26 361	26 198	26 229	26 367	26 203	26 284	26 422	26 258
	lb	57,795	58,099	57,740	57,807	58,111	57,752	57,929	58,233	57,873

*Static tipping loads and operating weights shown are based on a machine configuration with Michelin 26.5R25 XHA2 L3 Radial tires, full fluids, operator, standard counterweight, cold start, roading fenders, Product Link, open differential axles (front/rear), power train guard, secondary steering, and sound suppression.

**Measured 102 mm (4") behind tip of cutting edge with bucket hinge pin as pivot point in accordance with SAE J732C.

(§) Specifications and ratings conform to all applicable standards recommended by the Society of Automotive Engineers, including SAE Standard J732C governing loader ratings.

(ISO) Full compliance to ISO 14397-1 (2007) Sections 1 thru 6, which requires 2% verification between calculations and testing.

(Rigid Tire) Compliance to ISO 14397-1 (2007) Sections 1 thru 5.

NOTE: Bucket availability varies by region. Consult your local dealer for availability.

Bucket Type	General Purpose — Pin On						General Purpose — Fusion QC		
	Bolt-on Cutting Edges	Teeth & Segments	Teeth	Bolt-on Cutting Edges	Teeth & Segments	Teeth	Bolt-on Cutting Edges	Teeth & Segments	Teeth
Capacity — rated (§)	m ³	4.80	4.60	5.00	5.00	4.80	4.20	4.20	4.00
	yd ³	6.28	6.02	6.54	6.54	6.28	5.49	5.49	5.23
Capacity — struck (§)	m ³	4.10	3.90	4.30	4.30	4.10	3.70	3.70	3.50
	yd ³	5.36	5.10	5.62	5.62	5.36	4.84	4.84	4.58
Width (§)	mm	3220	3271	3271	3220	3271	3220	3271	3271
	ft/in	10'6"	10'8"	10'8"	10'6"	10'8"	10'6"	10'8"	10'8"
Dump clearance at maximum lift and 45° discharge (§)	mm	3154	2999	2999	3137	2982	2982	3195	3041
	ft/in	10'4"	9'10"	9'10"	10'3"	9'9"	9'9"	10'5"	9'11"
Reach at maximum lift and 45° discharge (§)	mm	1392	1528	1528	1407	1543	1543	1367	1504
	ft/in	4'6"	5'0"	5'0"	4'7"	5'0"	5'0"	4'5"	4'11"
Reach at level lift arm and bucket level (§)	mm	3049	3254	3254	3072	3277	3277	3000	3205
	ft/in	10'0"	10'8"	10'8"	10'0"	10'9"	10'9"	9'10"	10'6"
Digging depth (§)	mm	103	103	73	103	103	73	103	73
	in	4.0	4.0	2.8	4.0	4.0	2.8	4.0	2.8
Overall length	mm	9223	9447	9447	9246	9470	9470	9175	9398
	ft/in	30'4"	31'0"	31'0"	30'4"	31'1"	31'1"	30'2"	30'10"
Overall height with bucket at maximum lift	mm	6031	6031	6031	6284	6284	6284	6036	6036
	ft/in	19'10"	19'10"	19'10"	20'8"	20'8"	20'8"	19'10"	19'10"
Loader clearance circle with bucket at carry position (§)	mm	14 976	15 157	15 157	14 989	15 170	15 170	14 944	15 126
	ft/in	49'2"	49'9"	49'9"	49'3"	49'10"	49'10"	49'1"	49'8"
Static tipping load, straight (ISO)*	kg	18 683	18 500	20 705	18 779	18 595	18 832	18 260	18 430
	lb	41,179	40,775	45,634	41,390	40,984	41,507	40,246	39,848
Static tipping load, straight (Rigid Tire)*	kg	20 017	19 830	22 448	20 115	19 927	20 166	19 563	19 379
	lb	44,118	43,705	49,475	44,334	43,919	44,447	43,118	42,711
Static tipping load, articulated (ISO)*	kg	16 317	16 132	18 062	16 414	16 228	16 449	15 906	15 723
	lb	35,963	35,554	39,810	36,177	35,767	36,254	35,057	34,653
Static tipping load, articulated (Rigid Tire)*	kg	17 642	17 455	19 773	17 739	17 551	17 772	17 205	17 369
	lb	38,884	38,471	43,580	39,097	38,683	39,171	37,920	37,513
Breakout force** (§)	kN	196	194	207	198	197	210	203	201
	lbf	44,075	43,766	46,655	44,634	44,325	47,205	45,615	45,306
Operating weight*	kg	26 212	26 350	26 186	26 325	26 463	26 299	26 600	26 574
	lb	57,770	58,074	57,714	58,019	58,323	57,963	58,625	58,569

*Static tipping loads and operating weights shown are based on a machine configuration with Michelin 26.5R25 XHA2 L3 Radial tires, full fluids, operator, standard counterweight, cold start, roading fenders, Product Link, open differential axles (front/rear), power train guard, secondary steering, and sound suppression.

**Measured 102 mm (4") behind tip of cutting edge with bucket hinge pin as pivot point in accordance with SAE J732C.

(§) Specifications and ratings conform to all applicable standards recommended by the Society of Automotive Engineers, including SAE Standard J732C governing loader ratings.

(ISO) Full compliance to ISO 14397-1 (2007) Sections 1 thru 6, which requires 2% verification between calculations and testing.

(Rigid Tire) Compliance to ISO 14397-1 (2007) Sections 1 thru 5.

NOTE: Bucket availability varies by region. Consult your local dealer for availability.

Bucket Type		General Purpose — Fusion QC									
		Bolt-on Cutting Edges	Teeth & Segments	Teeth	Bolt-on Cutting Edges	Teeth & Segments	Teeth	Bolt-on Cutting Edges	Teeth & Segments	Teeth	
Edge Type											
	Capacity — rated (§)	m ³	4.40	4.40	4.20	4.60	4.60	4.40	4.80	4.80	4.60
		yd ³	5.75	5.75	5.49	6.02	6.02	5.75	6.28	6.28	6.02
Capacity — struck (§)		m ³	3.80	3.80	3.60	4.00	4.00	3.80	4.10	4.10	3.90
		yd ³	4.97	4.97	4.71	5.23	5.23	4.97	5.36	5.36	5.10
Width (§)		mm	3220	3271	3271	3220	3271	3271	3220	3271	3271
		ft/in	10'6"	10'8"	10'8"	10'6"	10'8"	10'8"	10'6"	10'8"	10'8"
Dump clearance at maximum lift and 45° discharge (§)		mm	3200	3047	3047	3157	3003	3003	3130	2975	2975
		ft/in	10'6"	9'11"	9'11"	10'4"	9'10"	9'10"	10'3"	9'9"	9'9"
Reach at maximum lift and 45° discharge (§)		mm	1362	1500	1500	1397	1535	1535	1419	1555	1555
		ft/in	4'5"	4'11"	4'11"	4'7"	5'0"	5'0"	4'7"	5'1"	5'1"
Reach at level lift arm and bucket level (§)		mm	2993	3198	3198	3050	3255	3255	3085	3290	3290
		ft/in	9'9"	10'5"	10'5"	10'0"	10'8"	10'8"	10'1"	10'9"	10'9"
Digging depth (§)		mm	103	103	73	103	103	73	103	103	73
		in	4.0	4.0	2.8	4.0	4.0	2.8	4.0	4.0	2.8
Overall length		mm	9167	9391	9391	9224	9448	9448	9259	9483	9483
		ft/in	30'1"	30'10"	30'10"	30'4"	31'0"	31'0"	30'5"	31'2"	31'2"
Overall height with bucket at maximum lift		mm	6205	6205	6205	6211	6211	6211	6270	6270	6270
		ft/in	20'5"	20'5"	20'5"	20'5"	20'5"	20'5"	20'7"	20'7"	20'7"
Loader clearance circle with bucket at carry position (§)		mm	14 940	15 122	15 122	14 971	15 154	15 154	14 991	15 174	15 174
		ft/in	49'1"	49'8"	49'8"	49'2"	49'9"	49'9"	49'3"	49'10"	49'10"
Static tipping load, straight (ISO)*		kg	18 263	18 082	18 439	18 113	17 931	18 282	18 105	17 922	18 271
		lb	40,252	39,853	40,639	39,921	39,520	40,293	39,903	39,500	40,270
Static tipping load, straight (Rigid Tire)*		kg	19 578	19 393	19 767	19 425	19 239	19 606	19 423	19 236	19 602
		lb	43,150	42,742	43,566	42,812	42,403	43,212	42,808	42,396	43,203
Static tipping load, articulated (ISO)*		kg	15 902	15 719	16 060	15 761	15 577	15 912	15 754	15 569	15 903
		lb	35,049	34,645	35,396	34,738	34,332	35,072	34,722	34,314	35,051
Static tipping load, articulated (Rigid Tire)*		kg	17 213	17 028	17 383	17 070	16 884	17 233	17 068	16 881	17 230
		lb	37,937	37,530	38,312	37,622	37,212	37,982	37,619	37,207	37,975
Breakout force** (§)		kN	203	202	216	195	194	207	190	189	201
		lbf	45,788	45,479	48,572	43,941	43,632	46,510	42,897	42,588	45,348
Operating weight*		kg	26 642	26 780	26 616	26 700	26 838	26 675	26 695	26 833	26 670
		lb	58,718	59,022	58,662	58,847	59,151	58,791	58,836	59,140	58,780

*Static tipping loads and operating weights shown are based on a machine configuration with Michelin 26.5R25 XHA2 L3 Radial tires, full fluids, operator, standard counterweight, cold start, roading fenders, Product Link, open differential axles (front/rear), power train guard, secondary steering, and sound suppression.

**Measured 102 mm (4") behind tip of cutting edge with bucket hinge pin as pivot point in accordance with SAE J732C.

(§) Specifications and ratings conform to all applicable standards recommended by the Society of Automotive Engineers, including SAE Standard J732C governing loader ratings.

(ISO) Full compliance to ISO 14397-1 (2007) Sections 1 thru 6, which requires 2% verification between calculations and testing.

(Rigid Tire) Compliance to ISO 14397-1 (2007) Sections 1 thru 5.

NOTE: Bucket availability varies by region. Consult your local dealer for availability.

Bucket Type		General Purpose — Fusion QC			Material Handling — Pin On			Rock — Pin On***		
		Bolt-on Cutting Edges	Teeth & Segments	Teeth	Bolt-on Cutting Edges	Teeth & Segments	Teeth	Bolt-on Cutting Edges	Teeth & Segments	Teeth
Capacity — rated (§)	m ³	5.00	5.00	4.80	4.60	4.60	4.40	3.60	3.60	3.40
	yd ³	6.54	6.54	6.28	6.02	6.02	5.75	4.71	4.71	4.45
Capacity — struck (§)	m ³	4.30	4.30	4.10	3.90	3.90	3.70	3.10	3.10	2.90
	yd ³	5.62	5.62	5.36	5.10	5.10	4.84	4.05	4.05	3.79
Width (§)	mm	3220	3271	3271	3220	3271	3271	3252	3252	3252
	ft/in	10'6"	10'8"	10'8"	10'6"	10'8"	10'8"	10'8"	10'8"	10'8"
Dump clearance at maximum lift and 45° discharge (§)	mm	3106	2951	2951	3120	2957	2957	3336	3248	3248
	ft/in	10'2"	9'8"	9'8"	10'2"	9'8"	9'8"	10'11"	10'7"	10'7"
Reach at maximum lift and 45° discharge (§)	mm	1440	1576	1576	1286	1413	1413	1420	1528	1528
	ft/in	4'8"	5'2"	5'2"	4'2"	4'7"	4'7"	4'7"	5'0"	5'0"
Reach at level lift arm and bucket level (§)	mm	3117	3322	3322	3014	3219	3219	2964	3104	3104
	ft/in	10'2"	10'10"	10'10"	9'10"	10'6"	10'6"	9'8"	10'2"	10'2"
Digging depth (§)	mm	103	103	73	103	103	73	44	44	4
	in	4.0	4.0	2.8	4.0	4.0	2.8	1.7	1.7	0.1
Overall length	mm	9291	9515	9515	9188	9412	9412	9127	9272	9272
	ft/in	30'6"	31'3"	31'3"	30'2"	30'11"	30'11"	30'0"	30'6"	30'6"
Overall height with bucket at maximum lift	mm	6296	6296	6296	6162	6162	6162	6042	6042	6042
	ft/in	20'8"	20'8"	20'8"	20'3"	20'3"	20'3"	19'10"	19'10"	19'10"
Loader clearance circle with bucket at carry position (§)	mm	15 009	15 193	15 193	14 957	15 137	15 137	14 978	15 061	15 061
	ft/in	49'3"	49'11"	49'11"	49'1"	49'8"	49'8"	49'2"	49'5"	49'5"
Static tipping load, straight (ISO)*	kg	17 986	17 802	18 150	18 595	18 413	18 653	19 302	19 235	19 616
	lb	39,642	39,237	40,003	40,983	40,582	41,111	42,543	42,394	43,234
Static tipping load, straight (Rigid Tire)*	kg	19 306	19 119	19 483	19 901	19 715	19 958	20 641	20 572	20 963
	lb	42,552	42,138	42,941	43,862	43,453	43,988	45,494	45,342	46,202
Static tipping load, articulated (ISO)*	kg	15 636	15 450	15 783	16 235	16 051	16 274	16 872	16 804	17 167
	lb	34,462	34,052	34,786	35,782	35,376	35,869	37,187	37,036	37,837
Static tipping load, articulated (Rigid Tire)*	kg	16 953	16 766	17 112	17 534	17 349	17 573	18 203	18 134	18 504
	lb	37,366	36,952	37,716	38,646	38,237	38,732	40,120	39,968	40,783
Breakout force** (§)	kN	186	185	196	201	199	213	222	222	231
	lbf	41,881	41,572	44,224	45,174	44,865	47,882	50,090	49,982	52,114
Operating weight*	kg	26 786	26 924	26 761	26 279	26 417	26 253	26 934	26 985	26 760
	lb	59,036	59,340	58,980	57,918	58,222	57,862	59,361	59,473	58,977

*Static tipping loads and operating weights shown are based on a machine configuration with Michelin 26.5R25 XHA2 L3 Radial tires, full fluids, operator, standard counterweight, cold start, roading fenders, Product Link, open differential axles (front/rear), power train guard, secondary steering, and sound suppression.

**Measured 102 mm (4") behind tip of cutting edge with bucket hinge pin as pivot point in accordance with SAE J732C.

***Rock bucket specifications are given on Michelin 26.5R25 XLDD2 L5 Radial tires.

(§) Specifications and ratings conform to all applicable standards recommended by the Society of Automotive Engineers, including SAE Standard J732C governing loader ratings.

(ISO) Full compliance to ISO 14397-1 (2007) Sections 1 thru 6, which requires 2% verification between calculations and testing.

(Rigid Tire) Compliance to ISO 14397-1 (2007) Sections 1 thru 5.

NOTE: Bucket availability varies by region. Consult your local dealer for availability.

Bucket Type		Rock – Pin On***			Rock – Fusion QC***			Coal – Pin On	Coal – Fusion QC	High Lift Change in Specs
		Bolt-on Cutting Edges	Teeth & Segments	Teeth	Bolt-on Cutting Edges	Teeth & Segments	Teeth	Bolt-on Cutting Edges	Bolt-on Cutting Edges	
Capacity – rated (§)	m ³	4.00	4.00	3.80	3.60	3.60	3.40	7.10	7.10	–
	yd ³	5.23	5.23	4.97	4.71	4.71	4.45	9.29	9.29	–
Capacity – struck (§)	m ³	3.50	3.50	3.30	3.10	3.10	2.90	6.20	6.20	–
	yd ³	4.58	4.58	4.32	4.05	4.05	3.79	8.11	8.11	–
Width (§)	mm	3252	3252	3252	3252	3252	3252	3447	3447	–
	ft/in	10'8"	10'8"	10'8"	10'8"	10'8"	10'8"	11'3"	11'3"	–
Dump clearance at maximum lift and 45° discharge (§)	mm	3233	3142	3142	3310	3222	3222	2842	2819	335
	ft/in	10'7"	10'3"	10'3"	10'10"	10'6"	10'6"	9'3"	9'2"	1'1"
Reach at maximum lift and 45° discharge (§)	mm	1463	1571	1571	1455	1563	1563	1544	1584	23
	ft/in	4'9"	5'1"	5'1"	4'9"	5'1"	5'1"	5'0"	5'2"	1"
Reach at level lift arm and bucket level (§)	mm	3073	3214	3214	3008	3147	3147	3393	3438	273
	ft/in	10'1"	10'6"	10'6"	9'10"	10'3"	10'3"	11'1"	11'3"	10"
Digging depth (§)	mm	44	44	44	44	44	4	117	105	–4
	in	1.7	1.7	1.7	1.7	1.7	0.1	4.6	4.1	–0.1
Overall length	mm	9236	9380	9380	9171	9315	9315	9578	9614	336
	ft/in	30'4"	30'10"	30'10"	30'2"	30'7"	30'7"	31'6"	31'7"	1'2"
Overall height with bucket at maximum lift	mm	6159	6159	6159	6060	6060	6060	6546	6581	336
	ft/in	20'3"	20'3"	20'3"	19'11"	19'11"	19'11"	21'6"	21'8"	1'2"
Loader clearance circle with bucket at carry position (§)	mm	15 039	15 123	15 123	14 996	15 081	15 081	15 385	15 401	332
	ft/in	49'5"	49'8"	49'8"	49'3"	49'6"	49'6"	50'6"	50'7"	1'2"
Static tipping load, straight (ISO)*	kg	19 183	19 114	19 459	18 779	18 710	19 158	17 394	16 779	–1558
	lb	42,281	42,128	42,887	41,390	41,238	42,225	38,337	36,983	–3434
Static tipping load, straight (Rigid Tire)*	kg	20 544	20 474	20 829	20 105	20 035	20 500	18 728	18 106	–1721
	lb	45,281	45,125	45,907	44,312	44,157	45,184	41,277	39,906	–3794
Static tipping load, articulated (ISO)*	kg	16 744	16 674	17 016	16 368	16 299	16 730	15 072	14 465	–1391
	lb	36,905	36,750	37,503	36,076	35,923	36,873	33,220	31,882	–3066
Static tipping load, articulated (Rigid Tire)*	kg	18 098	18 027	18 376	17 690	17 620	18 065	16 407	15 797	–1568
	lb	39,889	39,733	40,501	38,990	38,835	39,816	36,161	34,817	–3457
Breakout force** (§)	kN	204	204	212	215	214	223	154	149	–5
	lbf	45,999	45,886	47,764	48,357	48,247	50,268	34,604	33,479	–1327
Operating weight*	kg	27 081	27 132	26 907	27 326	27 378	27 153	26 946	27 506	85
	lb	59,685	59,797	59,301	60,225	60,339	59,844	59,387	60,622	186

*Static tipping loads and operating weights shown are based on a machine configuration with Michelin 26.5R25 XHA2 L3 Radial tires, full fluids, operator, standard counterweight, cold start, roading fenders, Product Link, open differential axles (front/rear), power train guard, secondary steering, and sound suppression.

**Measured 102 mm (4") behind tip of cutting edge with bucket hinge pin as pivot point in accordance with SAE J732C.

***Rock bucket specifications are given on Michelin 26.5R25 XLDD2 L5 Radial tires.

(§) Specifications and ratings conform to all applicable standards recommended by the Society of Automotive Engineers, including SAE Standard J732C governing loader ratings.

(ISO) Full compliance to ISO 14397-1 (2007) Sections 1 thru 6, which requires 2% verification between calculations and testing.

(Rigid Tire) Compliance to ISO 14397-1 (2007) Sections 1 thru 5.

NOTE: Bucket availability varies by region. Consult your local dealer for availability.

Wheel Loaders Integrated Toolcarriers

Performance Data ● 972K Extended Capacity

Bucket Type	General Purpose — Pin On						
	Edge Type	Bolt-on Cutting Edges	Teeth & Segments	Teeth	Bolt-on Cutting Edges	Teeth & Segments	Teeth
Capacity — rated (§)	m ³	4.60	4.60	4.40	4.90	4.90	4.70
	yd ³	6.02	6.02	5.75	6.41	6.41	6.15
Capacity — struck (§)	m ³	4.05	4.05	3.90	4.20	4.20	4.00
	yd ³	5.30	5.30	5.10	5.49	5.49	5.23
Width (§)	mm	3220	3271	3271	3220	3271	3271
	ft/in	10'6"	10'8"	10'8"	10'6"	10'8"	10'8"
Dump clearance at maximum lift and 45° discharge (§)	mm	2978	2824	2824	2920	2765	2765
	ft/in	9'9"	9'3"	9'3"	9'6"	9'0"	9'0"
Reach at maximum lift and 45° discharge (§)	mm	1400	1537	1537	1448	1584	1584
	ft/in	4'7"	5'0"	5'0"	4'9"	5'2"	5'2"
Reach at level lift arm and bucket level (§)	mm	2857	3062	3062	2933	3138	3138
	ft/in	9'4"	10'0"	10'0"	9'7"	10'3"	10'3"
Digging depth (§)	mm	123	123	93	123	123	93
	in	4.8	4.8	3.6	4.8	4.8	3.6
Overall length	mm	8996	9221	9221	9072	9297	9297
	ft/in	29'7"	30'4"	30'4"	29'10"	30'7"	30'7"
Overall height with bucket at maximum lift	mm	5875	5875	5875	6095	6095	6095
	ft/in	19'4"	19'4"	19'4"	20'0"	20'0"	20'0"
Loader clearance circle with bucket at carry position (§)	mm	14 787	14 961	14 961	14 827	15 001	15 001
	ft/in	48'7"	49'1"	49'1"	48'8"	49'3"	49'3"
Static tipping load, straight (ISO)*	kg	20 204	20 021	20 388	20 052	19 867	20 098
	lb	44,531	44,127	44,936	44,194	43,787	44,296
Static tipping load, straight (Rigid Tire)*	kg	21 762	21 574	21 959	21 624	21 434	21 667
	lb	47,964	47,549	48,397	47,660	47,241	47,755
Static tipping load, articulated (ISO)*	kg	17 668	17 482	17 836	17 520	17 333	17 546
	lb	38,940	38,531	39,312	38,615	38,202	38,672
Static tipping load, articulated (Rigid Tire)*	kg	19 203	19 015	19 384	19 071	18 881	19 094
	lb	42,325	41,910	42,722	42,032	41,614	42,085
Breakout force** (§)	kN	215	214	228	204	202	215
	lbf	48,470	48,095	51,358	45,923	45,550	48,516
Operating weight*	kg	26 062	26 200	26 037	26 185	26 323	26 160
	lb	57,440	57,744	57,384	57,712	58,016	57,656

*Static tipping loads and operating weights shown are based on a machine configuration with Michelin 26.5R25 XHA2 L3 Radial tires, full fluids, operator, standard counterweight, cold start, roading fenders, Product Link, open differential axles (front/rear), power train guard, secondary steering, and sound suppression.

**Measured 102 mm (4") behind tip of cutting edge with bucket hinge pin as pivot point in accordance with SAE J732C.

(§) Specifications and ratings conform to all applicable standards recommended by the Society of Automotive Engineers, including SAE Standard J732C governing loader ratings.

(ISO) Full compliance to ISO 14397-1 (2007) Sections 1 thru 6, which requires 2% verification between calculations and testing.

(Rigid Tire) Compliance to ISO 14397-1 (2007) Sections 1 thru 5.

NOTE: Bucket availability varies by region. Consult your local dealer for availability.

Bucket Type	General Purpose — Fusion QC						
	Edge Type	Bolt-on Cutting Edges	Teeth & Segments	Teeth	Bolt-on Cutting Edges	Teeth & Segments	Teeth
Capacity — rated (§)	m ³	4.60	4.60	4.40	4.90	4.90	4.70
	yd ³	6.02	6.02	5.75	6.41	6.41	6.15
Capacity — struck (§)	m ³	4.05	4.05	3.90	4.20	4.20	4.00
	yd ³	5.30	5.30	5.10	5.49	5.49	5.23
Width (§)	mm	3220	3271	3271	3220	3271	3271
	ft/in	10'6"	10'8"	10'8"	10'6"	10'8"	10'8"
Dump clearance at maximum lift and 45° discharge (§)	mm	2948	2794	2794	2899	2744	2744
	ft/in	9'8"	9'2"	9'2"	9'6"	9'0"	9'0"
Reach at maximum lift and 45° discharge (§)	mm	1436	1573	1573	1484	1621	1621
	ft/in	4'8"	5'1"	5'1"	4'10"	5'3"	5'3"
Reach at level lift arm and bucket level (§)	mm	2903	3108	3108	2975	3180	3180
	ft/in	9'6"	10'2"	10'2"	9'9"	10'5"	10'5"
Digging depth (§)	mm	122	122	92	115	115	85
	in	4.8	4.8	3.6	4.5	4.5	3.3
Overall length	mm	9041	9267	9267	9108	9333	9333
	ft/in	29'8"	30'5"	30'5"	29'11"	30'8"	30'8"
Overall height with bucket at maximum lift	mm	6039	6039	6039	6126	6126	6126
	ft/in	19'10"	19'10"	19'10"	20'2"	20'2"	20'2"
Loader clearance circle with bucket at carry position (§)	mm	14 804	14 981	14 981	14 837	15 015	15 015
	ft/in	48'7"	49'2"	49'2"	48'9"	49'4"	49'4"
Static tipping load, straight (ISO)*	kg	19 674	19 491	19 844	19 574	19 389	19 752
	lb	43,362	42,959	43,738	43,141	42,734	43,534
Static tipping load, straight (Rigid Tire)*	kg	21 217	21 029	21 404	21 141	20 952	21 335
	lb	46,763	46,350	47,176	46,596	46,178	47,023
Static tipping load, articulated (ISO)*	kg	17 155	16 969	17 308	17 052	16 865	17 213
	lb	37,809	37,400	38,147	37,584	37,171	37,937
Static tipping load, articulated (Rigid Tire)*	kg	18 681	18 493	18 850	18 603	18 413	18 777
	lb	41,173	40,759	41,545	41,001	40,583	41,385
Breakout force** (§)	kN	208	207	220	198	196	209
	lbf	46,886	46,513	49,589	44,570	44,204	47,022
Operating weight*	kg	26 508	26 646	26 483	26 598	26 736	26 573
	lb	58,424	58,728	58,368	58,622	58,926	58,567

*Static tipping loads and operating weights shown are based on a machine configuration with Michelin 26.5R25 XHA2 L3 Radial tires, full fluids, operator, standard counterweight, cold start, roading fenders, Product Link, open differential axles (front/rear), power train guard, secondary steering, and sound suppression.

**Measured 102 mm (4") behind tip of cutting edge with bucket hinge pin as pivot point in accordance with SAE J732C.

(§) Specifications and ratings conform to all applicable standards recommended by the Society of Automotive Engineers, including SAE Standard J732C governing loader ratings.

(ISO) Full compliance to ISO 14397-1 (2007) Sections 1 thru 6, which requires 2% verification between calculations and testing.

(Rigid Tire) Compliance to ISO 14397-1 (2007) Sections 1 thru 5.

NOTE: Bucket availability varies by region. Consult your local dealer for availability.

Wheel Loaders Integrated Toolcarriers

Performance Data ● 980K

Bucket Type	General Purpose – Pin On			Rock – Pin On***			Coal – Pin On	High Lift Change in Specs	
	Edge Type	Bolt-on Cutting Edges	Teeth & Segments	Teeth	Bolt-on Cutting Edges	Teeth & Segments	Teeth		Bolt-on Cutting Edges
Capacity – rated (\$)	m ³	5.40	5.40	5.00	4.40	4.40	4.30	8.20	—
	yd ³	7.06	7.06	6.54	5.75	5.75	5.62	10.73	—
Capacity – struck (\$)	m ³	5.00	5.00	4.60	3.21	3.20	3.10	6.47	—
	yd ³	6.54	6.54	6.02	4.20	4.19	4.05	8.46	—
Width (\$)	mm	3447	3535	3535	3504	3504	3504	3638	—
	ft/in	11'3"	11'7"	11'7"	11'5"	11'5"	11'5"	11'11"	—
Dump clearance at maximum lift and 45° discharge (\$)	mm	3273	3107	3107	3101	3101	3101	2917	220
	ft/in	10'8"	10'2"	10'2"	10'2"	10'2"	10'2"	9'6"	8"
Reach at maximum lift and 45° discharge (\$)	mm	1556	1693	1693	1844	1844	1844	1700	0
	ft/in	5'1"	5'6"	5'6"	6'0"	6'0"	6'0"	5'6"	0"
Reach at level lift arm and bucket level (\$)	mm	3040	3252	3252	3360	3360	3360	3411	160
	ft/in	9'11"	10'8"	10'8"	11'0"	11'0"	11'0"	11'2"	6"
Digging depth (\$)	mm	103	103	68	106	106	71	108	0
	in	4.0	4.0	2.6	4.1	4.1	2.8	4.2	0
Overall length	mm	9509	9750	9750	9844	9844	9844	9883	201
	ft/in	31'3"	32'0"	32'0"	32'4"	32'4"	32'4"	32'6"	8"
Overall height with bucket at maximum lift	mm	6421	6421	6421	6184	6184	6184	6536	221
	ft/in	21'1"	21'1"	21'1"	20'4"	20'4"	20'4"	21'6"	9"
Loader clearance circle with bucket at carry position (\$)	mm	15 853	16 076	16 076	16 094	16 093	16 093	16 234	175
	ft/in	52'1"	52'9"	52'9"	52'10"	52'10"	52'10"	53'4"	7"
Static tipping load, straight (ISO)*	kg	21 822	21 637	22 066	22 141	22 178	22 640	20 819	-1831
	lb	48,096	47,689	48,635	48,799	48,880	49,900	45,887	-4036
Static tipping load, straight (Rigid Tire)*	kg	23 185	22 999	23 445	23 508	23 554	24 027	22 238	-2026
	lb	51,101	50,691	51,673	51,812	51,915	52,955	49,012	-4467
Static tipping load, articulated (ISO)*	kg	19 267	19 082	19 489	19 536	19 555	20 010	18 293	-1656
	lb	42,464	42,058	42,953	43,057	43,100	44,103	40,318	-3651
Static tipping load, articulated (Rigid Tire)*	kg	20 484	20 298	20 719	20 754	20 782	21 246	19 567	-1836
	lb	45,148	44,738	45,666	45,742	45,804	46,826	43,125	-4048
Breakout force** (\$)	kN	238	235	254	223	222	241	186	3
	lbf	53,548	52,996	57,101	50,282	50,093	54,147	41,956	813
Operating weight*	kg	31 244	31 383	31 207	31 767	31 842	31 547	31 831	115
	lb	68,862	69,167	68,780	70,013	70,178	69,528	70,156	253

*Static tipping loads and operating weights shown are based on a machine configuration with Michelin 29.5R25 XLDD1 L4 Radial tires, full fluids, operator, standard counterweight, standard transmission, cold start, roading fenders, Product Link, open differential axles (front/rear), power train guard, secondary steering, and sound suppression.

**Measured 102 mm (4") behind tip of cutting edge with bucket hinge pin as pivot point in accordance with SAE J732C.

***Rock bucket specifications are given on Michelin 29.5R25 XLDD2 L5 Radial tires.

(§) Specifications and ratings conform to all applicable standards recommended by the Society of Automotive Engineers, including SAE Standard J732C governing loader ratings.

(ISO) Full compliance to ISO 14397-1 (2007) Sections 1 thru 6, which requires 2% verification between calculations and testing.

(Rigid Tire) Compliance to ISO 14397-1 (2007) Sections 1 thru 5.

NOTE: Bucket availability varies by region. Consult your local dealer for availability.

Bucket Type	General Purpose – Pin On						Material Handling – Pin On			
		Bolt-on Cutting Edges	Teeth & Segments	Teeth	Bolt-on Cutting Edges	Teeth & Segments	Teeth	Bolt-on Cutting Edges	Teeth & Segments	Teeth
Edge Type										
Capacity – rated (§)	m ³	5.70	5.70	5.30	6.00	6.00	5.80	5.70	5.70	5.50
	yd ³	7.46	7.46	6.93	7.85	7.85	7.59	7.46	7.46	7.19
Capacity – struck (§)	m ³	4.50	4.50	4.30	5.30	5.30	5.10	5.06	5.06	4.86
	yd ³	5.89	5.89	5.62	6.93	6.93	6.67	6.62	6.62	6.36
Width (§)	mm	3447	3535	3535	3447	3535	3535	3447	3535	3535
	ft/in	11'3"	11'7"	11'7"	11'3"	11'7"	11'7"	11'3"	11'7"	11'7"
Dump clearance at maximum lift and 45° discharge (§)	mm	3204	3037	3037	3187	3019	3019	3105	2928	2928
	ft/in	10'6"	9'11"	9'11"	10'5"	9'10"	9'10"	10'2"	9'7"	9'7"
Reach at maximum lift and 45° discharge (§)	mm	1604	1738	1738	1625	1760	1760	1519	1641	1641
	ft/in	5'3"	5'8"	5'8"	5'4"	5'9"	5'9"	4'11"	5'4"	5'4"
Reach at level lift arm and bucket level (§)	mm	3124	3336	3336	3152	3364	3364	3149	3361	3361
	ft/in	10'3"	10'11"	10'11"	10'4"	11'0"	11'0"	10'4"	11'0"	11'0"
Digging depth (§)	mm	103	103	68	103	103	68	103	103	68
	in	4.0	4.0	2.6	4.0	4.0	2.6	4.0	4.0	2.6
Overall length	mm	9593	9834	9834	9621	9862	9862	9618	9859	9859
	ft/in	31'6"	32'4"	32'4"	31'7"	32'5"	32'5"	31'7"	32'5"	32'5"
Overall height with bucket at maximum lift	mm	6243	6243	6243	6269	6269	6269	6242	6242	6242
	ft/in	20'6"	20'6"	20'6"	20'7"	20'7"	20'7"	20'6"	20'6"	20'6"
Loader clearance circle with bucket at carry position (§)	mm	15 898	16 123	16 123	15 913	16 138	16 138	15 911	16 137	16 137
	ft/in	52'2"	52'11"	52'11"	52'3"	53'0"	53'0"	52'3"	53'0"	53'0"
Static tipping load, straight (ISO)*	kg	23 011	22 826	23 262	22 869	22 683	23 116	22 514	22 331	22 749
	lb	50,717	50,308	51,271	50,404	49,994	50,949	49,621	49,217	50,139
Static tipping load, straight (Rigid Tire)*	kg	24 485	24 298	24 753	24 346	24 158	24 609	23 945	23 760	24 194
	lb	53,967	53,554	54,557	53,659	53,245	54,239	52,774	52,367	53,325
Static tipping load, articulated (ISO)*	kg	20 261	20 075	20 489	20 123	19 937	20 347	19 810	19 627	20 024
	lb	44,656	44,247	45,158	44,353	43,943	44,846	43,662	43,258	44,132
Static tipping load, articulated (Rigid Tire)*	kg	21 597	21 409	21 839	21 462	21 274	21 700	21 106	20 921	21 332
	lb	47,600	47,186	48,133	47,302	46,888	47,827	46,519	46,111	47,017
Breakout force** (§)	kN	224	222	239	220	218	234	221	218	234
	lbf	50,542	50,003	53,707	49,551	49,016	52,596	49,662	49,126	52,720
Operating weight*	kg	32 020	32 159	31 983	32 116	32 255	32 079	32 145	32 284	32 108
	lb	70,572	70,877	70,490	70,784	71,089	70,702	70,848	71,153	70,766

*Static tipping loads and operating weights shown are based on a machine configuration with Michelin 29.5R25 XLDD1 L4 Radial tires, full fluids, operator, standard counterweight, standard transmission, cold start, roading fenders, Product Link, open differential axles (front/rear), power train guard, secondary steering, and sound suppression.

**Measured 102 mm (4") behind tip of cutting edge with bucket hinge pin as pivot point in accordance with SAE J732C.

(§) Specifications and ratings conform to all applicable standards recommended by the Society of Automotive Engineers, including SAE Standard J732C governing loader ratings.

(ISO) Full compliance to ISO 14397-1 (2007) Sections 1 thru 6, which requires 2% verification between calculations and testing.

(Rigid Tire) Compliance to ISO 14397-1 (2007) Sections 1 thru 5.

NOTE: Bucket availability varies by region. Consult your local dealer for availability.

Bucket Type	General Purpose — Pin On									
	Edge Type	Bolt-on Cutting Edges	Teeth & Segments	Teeth	Bolt-on Cutting Edges	Teeth & Segments	Teeth	Bolt-on Cutting Edges	Teeth & Segments	Teeth
Capacity — rated	m ³	2.70	2.70	2.50	3.10	3.10	2.90	3.30	3.30	3.10
Capacity — 110% rated	m ³	2.97	2.97	2.75	3.41	3.41	3.19	3.63	3.63	3.41
Width	mm	2927	2994	2994	2927	2994	2994	2927	2994	2994
Dump clearance at maximum lift and 45° discharge	mm	3130	3015	3015	3050	2933	2933	3012	2893	2893
Reach at maximum lift and 45° discharge	mm	1212	1326	1326	1262	1374	1374	1292	1403	1403
Reach at level lift arm and bucket level	mm	2626	2787	2787	2720	2881	2881	2770	2931	2931
Digging depth	mm	86	86	56	86	86	56	86	86	56
Overall length	mm	8138	8312	8312	8238	8412	8412	8288	8462	8462
Overall height with bucket at maximum lift	mm	5557	5557	5557	5519	5519	5519	5693	5693	5693
Loader clearance circle with bucket at carry position	mm	13 764	13 928	13 928	13 819	13 984	13 984	13 847	14 013	14 013
Static tipping load, straight with tire squash*	kg	11 924	11 787	12 106	12 178	12 040	12 365	12 082	11 943	12 266
Static tipping load, straight without tire squash*	kg	12 582	12 444	12 773	12 854	12 714	13 050	12 759	12 619	12 952
Static tipping load, articulated with tire squash*	kg	10 408	10 271	10 576	10 594	10 455	10 764	10 503	10 363	10 671
Static tipping load, articulated without tire squash*	kg	11 053	10 915	11 228	11 286	11 147	11 466	11 197	11 057	11 374
Breakout force	kN	168	166	184	154	152	167	147	146	160
Operating weight*	kg	17 903	18 011	17 854	18 631	18 739	18 582	18 676	18 784	18 627
Reach @ 2134 mm height, 45° dumped	mm	1908	1970	1970	1923	1978	1978	1935	1986	1986
Clearance at full raise and dump (on stops)	mm	3028	2897	2897	2954	2823	2823	2917	2786	2786
Dump angle at full raise and dump (on stops)	degrees	53	53	53	52	52	52	52	52	52

*Static tipping loads and operating weights shown are based on standard machine configuration with 26.5R25 L3 Triangle TB516 radial tires, full fuel tank, coolants, lubricants, air conditioner and operator.

(ISO) Full compliance to ISO 14397-1 (2007) Sections 1 thru 6, which requires 2% verification between calculations and testing.

(Rigid Tire) Compliance to ISO 14397-1 (2007) Sections 1 thru 5.

NOTE: Machine and bucket availability varies by region. Consult your local dealer for availability.

Bucket Type	General Purpose — Pin On						
	Edge Type	Bolt-on Cutting Edges	Teeth & Segments	Teeth	Bolt-on Cutting Edges	Teeth & Segments	Teeth
Capacity — rated	m ³	3.40	3.40	3.20	3.60	3.60	3.40
Capacity — 110% rated	m ³	3.74	3.74	3.52	3.96	3.96	3.74
Width	mm	2927	2994	2994	2927	2994	2994
Dump clearance at maximum lift and 45° discharge	mm	2985	2867	2867	2939	2820	2820
Reach at maximum lift and 45° discharge	mm	1314	1425	1425	1351	1460	1460
Reach at level lift arm and bucket level	mm	2805	2966	2966	2865	3026	3026
Digging depth	mm	86	86	56	86	86	56
Overall length	mm	8323	8497	8497	8383	8557	8557
Overall height with bucket at maximum lift	mm	5723	5723	5723	5781	5781	5781
Loader clearance circle with bucket at carry position	mm	13 867	14 034	14 034	13 902	14 069	14 069
Static tipping load, straight with tire squash*	kg	12 020	11 880	12 198	11 904	11 763	12 084
Static tipping load, straight without tire squash*	kg	12 699	12 558	12 885	12 584	12 442	12 774
Static tipping load, articulated with tire squash*	kg	10 444	10 304	10 607	10 333	10 193	10 499
Static tipping load, articulated without tire squash*	kg	11 140	10 998	11 311	11 031	10 889	11 205
Breakout force	kN	143	142	155	137	135	147
Operating weight*	kg	18 706	18 814	18 657	18 764	18 872	18 715
Reach @ 2134 mm height, 45° dumped	mm	1945	1994	1994	1958	2003	2003
Clearance at full raise and dump (on stops)	mm	2891	2760	2760	2846	2716	2716
Dump angle at full raise and dump (on stops)	degrees	52	52	52	51	51	51

*Static tipping loads and operating weights shown are based on standard machine configuration with 26.5R25 L3 Triangle TB516 radial tires, full fuel tank, coolants, lubricants, air conditioner and operator.
(ISO) Full compliance to ISO 14397-1 (2007) Sections 1 thru 6, which requires 2% verification between calculations and testing.
(Rigid Tire) Compliance to ISO 14397-1 (2007) Sections 1 thru 5.

NOTE: Machine and bucket availability varies by region. Consult your local dealer for availability.

Bucket Type	General Purpose – Hook On			Material Handling – Pin On	
	Bolt-on Cutting Edges	Teeth & Segments	Teeth	Bolt-on Cutting Edges	
Edge Type					
Capacity – rated	m³	3.10	3.10	2.90	4.4
Capacity – 110% rated	m³	3.41	3.41	3.19	4.84
Width	mm	2927	2994	2994	3059
Dump clearance at maximum lift and 45° discharge	mm	3008	2891	2891	2782
Reach at maximum lift and 45° discharge	mm	1299	1410	1410	1362
Reach at level lift arm and bucket level	mm	2775	2936	2936	3002
Digging depth	mm	94	94	64	102
Overall length	mm	8299	8473	8473	8527
Overall height with bucket at maximum lift	mm	5662	5662	5662	5910
Loader clearance circle with bucket at carry position	mm	13 850	14 017	14 017	14 110
Static tipping load, straight with tire squash*	kg	11 577	11 439	11 755	11 184
Static tipping load, straight without tire squash*	kg	12 240	12 101	12 427	11 664
Static tipping load, articulated with tire squash*	kg	10 016	9878	10 179	9641
Static tipping load, articulated without tire squash*	kg	10 697	10 557	10 868	10 186
Breakout force	kN	146	145	159	123
Operating weight*	kg	19 109	19 217	19 060	18 330
Reach @ 2134 mm height, 45° dumped	mm	1940	1993	1993	1883
Clearance at full raise and dump (on stops)	mm	2907	2777	2777	2739
Dump angle at full raise and dump (on stops)	degrees	52	52	52	47.7

*Static tipping loads and operating weights shown are based on standard machine configuration with 26.5R25 L3 Triangle TB516 radial tires, full fuel tank, coolants, lubricants, air conditioner and operator. Hook On Bucket includes Quick Coupler.
(ISO) Full compliance to ISO 14397-1 (2007) Sections 1 thru 6, which requires 2% verification between calculations and testing.
(Rigid Tire) Compliance to ISO 14397-1 (2007) Sections 1 thru 5.

NOTE: Machine and bucket availability varies by region. Consult your local dealer for availability.

Bucket Type	General Purpose – Pin On						High Lift Change in Specs	
	Edge Type	Bolt-on Cutting Edges	Teeth & Segments	Bolt-on Cutting Edges	Teeth & Segments	Bolt-on Cutting Edges		Teeth & Segments
Capacity – rated (§)	m ³	2.70	2.70	3.10	3.10	3.40	3.40	—
	yd ³	3.53	3.53	4.05	4.05	4.45	4.45	—
Capacity – rated @ 110% fill factor	m ³	3.00	3.00	3.40	3.40	3.70	3.70	—
	yd ³	3.90	3.90	4.50	4.50	4.90	4.90	—
Width (§)	mm	2927	2994	2927	2994	2927	2994	—
	ft/in	9'7"	9'9"	9'7"	9'9"	9'7"	9'9"	—
Dump clearance at maximum lift and 45° discharge (§)	mm	2936	2821	2856	2738	2791	2672	495
	ft/in	9'7"	9'3"	9'4"	8'11"	9'1"	8'9"	1'7"
Reach at maximum lift and 45° discharge (§)	mm	1263	1377	1319	1430	1371	1481	67
	ft/in	4'1"	4'6"	4'3"	4'8"	4'5"	4'10"	2"
Reach at level lift arm and bucket level (§)	mm	2527	2688	2627	2788	2712	2873	405
	ft/in	8'3"	8'9"	8'7"	9'1"	8'10"	9'5"	1'3"
Digging depth (§)	mm	89	89	89	89	89	89	21
	in	3.5	3.5	3.5	3.5	3.5	3.5	0.8
Overall length	mm	7961	8135	8061	8235	8146	8320	605
	ft/in	26'2"	26'9"	26'6"	27'1"	26'9"	27'4"	2'0"
Overall height with bucket at maximum lift	mm	5363	5363	5325	5325	5529	5529	496
	ft/in	17'8"	17'8"	17'6"	17'6"	18'2"	18'2"	1'8"
Loader clearance circle with bucket at carry position (§)	mm	13 301	13 464	13 356	13 519	13 403	13 567	391
	ft/in	43'8"	44'3"	43'10"	44'5"	44'0"	44'7"	1'4"
Static tipping load, straight (ISO)*	kg	12 701	12 562	12 515	12 375	12 355	12 214	-341
	lb	27,993	27,688	27,584	27,275	27,230	26,919	-751
Static tipping load, straight (no tire deflection)*	kg	13 424	13 284	13 242	13 101	13 085	12 943	-398
	lb	29,586	29,279	29,186	28,875	28,841	28,526	-878
Static tipping load, articulated (ISO)*	kg	10 986	10 848	10 811	10 671	10 659	10 518	-416
	lb	24,214	23,909	23,827	23,519	23,494	23,182	-917
Static tipping load, articulated (no tire deflection)*	kg	11 711	11 571	11 540	11 398	11 392	11 249	-458
	lb	25,812	25,504	25,434	25,122	25,108	24,793	-1011
Breakout force** (§)	kN	163	162	150	149	140	138	-8
	lbf	36,840	36,573	33,756	33,491	31,477	31,214	-1892
Operating weight*	kg	18 231	18 339	18 320	18 428	18 395	18 503	1271
	lb	40,180	40,418	40,376	40,614	40,541	40,779	2800

*Static tipping loads and operating weights shown are based on a global machine configuration with Michelin 23.5R25 XHA2 L3 Radial tires, full fluids, operator, standard counterweight, standard linkage, cold start, roading fenders, Product Link, open differential axles (front/rear), power train guard, secondary steering, and sound suppression.

**Measured 102 mm (4") behind tip of cutting edge with bucket hinge pin as pivot point in accordance with SAE J732C.

(§) Specifications and ratings conform to all applicable standards recommended by the Society of Automotive Engineers, including SAE Standard J732C governing loader ratings.

(ISO) Full compliance to ISO 14397-1 (2007) Sections 1 thru 6, which requires 2% verification between calculations and testing.

(No Tire Deflection) Compliance to ISO 14397-1 (2007) Sections 1 thru 5.

Bucket Type		Material Handling – Pin On						High Lift Change in Specs
		Bolt-on Cutting Edges	Teeth & Segments	Bolt-on Cutting Edges	Teeth & Segments	Bolt-on Cutting Edges	Teeth & Segments	
Edge Type								
Capacity — rated (§)	m ³	3.20	3.20	3.40	3.40	3.60	3.60	—
	yd ³	4.19	4.19	4.45	4.45	4.71	4.71	—
Capacity — rated @ 110% fill factor	m ³	3.50	3.50	3.70	3.70	4.00	4.00	—
	yd ³	4.60	4.60	4.90	4.90	5.20	5.20	—
Width (§)	mm	2927	2994	2927	2994	2927	2994	—
	ft/in	9'7"	9'9"	9'7"	9'9"	9'7"	9'9"	—
Dump clearance at maximum lift and 45° discharge (§)	mm	2756	2631	2721	2596	2686	2560	495
	ft/in	9'0"	8'7"	8'11"	8'6"	8'9"	8'4"	1'7"
Reach at maximum lift and 45° discharge (§)	mm	1255	1358	1291	1393	1326	1428	67
	ft/in	4'1"	4'5"	4'2"	4'6"	4'4"	4'8"	2"
Reach at level lift arm and bucket level (§)	mm	2672	2833	2722	2883	2772	2933	405
	ft/in	8'9"	9'3"	8'11"	9'5"	9'1"	9'7"	1'3"
Digging depth (§)	mm	97	97	97	97	97	97	21
	in	3.8	3.8	3.8	3.8	3.8	3.8	0.8
Overall length	mm	8112	8286	8162	8336	8212	8386	605
	ft/in	26'8"	27'3"	26'10"	27'5"	27'0"	27'7"	2'0"
Overall height with bucket at maximum lift	mm	5490	5490	5539	5539	5589	5589	496
	ft/in	18'1"	18'1"	18'3"	18'3"	18'5"	18'5"	1'8"
Loader clearance circle with bucket at carry position (§)	mm	13 387	13 551	13 415	13 580	13 443	13 608	391
	ft/in	44'0"	44'6"	44'1"	44'7"	44'2"	44'8"	1'4"
Static tipping load, straight (ISO)*	kg	12 307	12 168	12 214	12 074	12 127	11 986	-341
	lb	27,125	26,818	26,921	26,612	26,729	26,418	-751
Static tipping load, straight (no tire deflection)*	kg	13 020	12 879	12 929	12 787	12 845	12 702	-398
	lb	28,696	28,386	28,497	28,184	28,311	27,997	-878
Static tipping load, articulated (ISO)*	kg	10 624	10 485	10 536	10 396	10 454	10 312	-416
	lb	23,417	23,109	23,223	22,914	23,040	22,729	-917
Static tipping load, articulated (no tire deflection)*	kg	11 340	11 199	11 254	11 112	11 174	11 031	-458
	lb	24,993	24,683	24,804	24,492	24,628	24,313	-1011
Breakout force** (§)	kN	144	143	138	137	133	132	-8
	lbf	32,489	32,223	31,199	30,934	29,997	29,733	-1892
Operating weight*	kg	18 352	18 460	18 400	18 508	18 446	18 554	1271
	lb	40,446	40,684	40,552	40,790	40,653	40,892	2800

*Static tipping loads and operating weights shown are based on a global machine configuration with Michelin 23.5R25 XHA2 L3 Radial tires, full fluids, operator, standard counterweight, standard linkage, cold start, roading fenders, Product Link, open differential axles (front/rear), power train guard, secondary steering, and sound suppression.

**Measured 102 mm (4") behind tip of cutting edge with bucket hinge pin as pivot point in accordance with SAE J732C.

(§) Specifications and ratings conform to all applicable standards recommended by the Society of Automotive Engineers, including SAE Standard J732C governing loader ratings.

(ISO) Full compliance to ISO 14397-1 (2007) Sections 1 thru 6, which requires 2% verification between calculations and testing.

(No Tire Deflection) Compliance to ISO 14397-1 (2007) Sections 1 thru 5.

Bucket Type		General Purpose – Pin On					High Lift Change in Specs	
		Bolt-on Cutting Edges	Teeth & Segments	Bolt-on Cutting Edges	Teeth & Segments	Bolt-on Cutting Edges		Teeth & Segments
Edge Type								
Capacity – rated (§)	m ³	3.10	3.10	3.40	3.40	3.60	3.60	—
	yd ³	4.05	4.05	4.45	4.45	4.71	4.71	—
Capacity – rated @ 110% fill factor	m ³	3.40	3.40	3.70	3.70	4.00	4.00	—
	yd ³	4.50	4.50	4.90	4.90	5.20	5.20	—
Width (§)	mm	2927	2994	2927	2994	2927	2994	—
	ft/in	9'7"	9'9"	9'7"	9'9"	9'7"	9'9"	—
Dump clearance at maximum lift and 45° discharge (§)	mm	3046	2928	2981	2862	2935	2816	305
	ft/in	9'11"	9'7"	9'9"	9'4"	9'7"	9'2"	1'0"
Reach at maximum lift and 45° discharge (§)	mm	1269	1380	1321	1431	1357	1467	117
	ft/in	4'1"	4'6"	4'4"	4'8"	4'5"	4'9"	4"
Reach at level lift arm and bucket level (§)	mm	2727	2888	2812	2973	2872	3033	305
	ft/in	8'11"	9'5"	9'2"	9'9"	9'5"	9'11"	1'0"
Digging depth (§)	mm	90	90	90	90	90	90	-35
	in	3.5	3.5	3.5	3.5	3.5	3.5	-1.3
Overall length	mm	8291	8464	8376	8549	8436	8609	375
	ft/in	27'3"	27'10"	27'6"	28'1"	27'9"	28'3"	1'3"
Overall height with bucket at maximum lift	mm	5515	5515	5719	5719	5777	5777	306
	ft/in	18'2"	18'2"	18'10"	18'10"	19'0"	19'0"	1'1"
Loader clearance circle with bucket at carry position (§)	mm	13 478	13 645	13 527	13 696	13 562	13 732	-5
	ft/in	44'3"	44'10"	44'5"	45'0"	44'6"	45'1"	-1"
Static tipping load, straight (ISO)*	kg	13 346	13 208	13 181	13 041	13 060	12 919	-1172
	lb	29,416	29,110	29,052	28,744	28,784	28,474	-2583
Static tipping load, straight (no tire deflection)*	kg	14 065	13 925	13 903	13 762	13 784	13 642	-1221
	lb	30,999	30,691	30,643	30,332	30,380	30,067	-2691
Static tipping load, articulated (ISO)*	kg	11 459	11 320	11 303	11 163	11 189	11 048	-1064
	lb	25,255	24,950	24,913	24,605	24,661	24,351	-2345
Static tipping load, articulated (no tire deflection)*	kg	12 190	12 050	12 038	11 897	11 926	11 784	-1109
	lb	26,867	26,559	26,533	26,221	26,285	25,972	-2444
Breakout force** (§)	kN	151	150	141	139	134	133	-9
	lbf	33,973	33,715	31,680	31,423	30,214	29,958	-2109
Operating weight*	kg	19 046	19 154	19 121	19 229	19 179	19 287	545
	lb	41,976	42,214	42,141	42,379	42,269	42,507	1200

*Static tipping loads and operating weights shown are based on a global machine configuration with Michelin 23.5R25 XHA2 L3 Radial tires, full fluids, operator, standard counterweight, standard linkage, cold start, roading fenders, Product Link, open differential axles (front/rear), power train guard, secondary steering, and sound suppression.

**Measured 102 mm (4") behind tip of cutting edge with bucket hinge pin as pivot point in accordance with SAE J732C.

(§) Specifications and ratings conform to all applicable standards recommended by the Society of Automotive Engineers, including SAE Standard J732C governing loader ratings.

(ISO) Full compliance to ISO 14397-1 (2007) Sections 1 thru 6, which requires 2% verification between calculations and testing.

(No Tire Deflection) Compliance to ISO 14397-1 (2007) Sections 1 thru 5.

Bucket Type		Material Handling – Pin On						High Lift Change in Specs
		Bolt-on Cutting Edges	Teeth & Segments	Bolt-on Cutting Edges	Teeth & Segments	Bolt-on Cutting Edges	Teeth & Segments	
Edge Type								
Capacity – rated (§)	m ³	3.40	3.40	3.60	3.60	3.80	3.80	–
	yd ³	4.45	4.45	4.71	4.71	4.97	4.97	–
Capacity – rated @ 110% fill factor	m ³	3.70	3.70	4.00	4.00	4.20	4.20	–
	yd ³	4.90	4.90	5.20	5.20	5.50	5.50	–
Width (§)	mm	2927	2994	2927	2994	2927	2994	–
	ft/in	9'7"	9'9"	9'7"	9'9"	9'7"	9'9"	–
Dump clearance at maximum lift and 45° discharge (§)	mm	2911	2786	2876	2750	2833	2707	305
	ft/in	9'6"	9'1"	9'5"	9'0"	9'3"	8'10"	1'0"
Reach at maximum lift and 45° discharge (§)	mm	1241	1343	1276	1378	1319	1421	117
	ft/in	4'0"	4'4"	4'2"	4'6"	4'3"	4'7"	4"
Reach at level lift arm and bucket level (§)	mm	2822	2983	2872	3033	2933	3094	305
	ft/in	9'3"	9'9"	9'5"	9'11"	9'7"	10'1"	1'0"
Digging depth (§)	mm	98	98	98	98	98	98	–35
	in	3.8	3.8	3.8	3.8	3.8	3.8	–1.3
Overall length	mm	8392	8565	8442	8615	8503	8676	375
	ft/in	27'7"	28'2"	27'9"	28'4"	27'11"	28'6"	1'3"
Overall height with bucket at maximum lift	mm	5729	5729	5779	5779	5828	5828	306
	ft/in	18'10"	18'10"	19'0"	19'0"	19'2"	19'2"	1'1"
Loader clearance circle with bucket at carry position (§)	mm	13 540	13 709	13 569	13 739	13 605	13 776	–5
	ft/in	44'6"	45'0"	44'7"	45'1"	44'8"	45'3"	–1"
Static tipping load, straight (ISO)*	kg	13 039	12 900	12 949	12 809	12 835	12 694	–1172
	lb	28,738	28,431	28,540	28,232	28,288	27,978	–2583
Static tipping load, straight (no tire deflection)*	kg	13 746	13 605	13 659	13 518	13 547	13 405	–1221
	lb	30,296	29,987	30,105	29,794	29,859	29,546	–2691
Static tipping load, articulated (ISO)*	kg	11 180	11 040	11 094	10 955	10 987	10 846	–1064
	lb	24,640	24,334	24,453	24,144	24,215	23,905	–2345
Static tipping load, articulated (no tire deflection)*	kg	11 900	11 760	11 818	11 677	11 712	11 570	–1109
	lb	26,228	25,919	26,047	25,736	25,815	25,502	–2444
Breakout force** (§)	kN	139	138	134	133	128	127	–9
	lbf	31,403	31,144	30,195	29,936	28,825	28,568	–2109
Operating weight*	kg	19 126	19 234	19 172	19 280	19 228	19 336	545
	lb	42,152	42,390	42,254	42,492	42,377	42,615	1200

*Static tipping loads and operating weights shown are based on a global machine configuration with Michelin 23.5R25 XHA2 L3 Radial tires, full fluids, operator, standard counterweight, standard linkage, cold start, roading fenders, Product Link, open differential axles (front/rear), power train guard, secondary steering, and sound suppression.

**Measured 102 mm (4") behind tip of cutting edge with bucket hinge pin as pivot point in accordance with SAE J732C.

(§) Specifications and ratings conform to all applicable standards recommended by the Society of Automotive Engineers, including SAE Standard J732C governing loader ratings.

(ISO) Full compliance to ISO 14397-1 (2007) Sections 1 thru 6, which requires 2% verification between calculations and testing.

(No Tire Deflection) Compliance to ISO 14397-1 (2007) Sections 1 thru 5.

Bucket Type		General Purpose — Pin On								High Lift Delta	
		Bolt-on Cutting Edges	Teeth & Segments	Bolt-on Cutting Edges	Teeth & Segments	Bolt-on Cutting Edges	Teeth & Segments	Bolt-on Cutting Edges	Teeth & Segments		
Edge Type	Capacity — rated	m ³	3.80	3.80	4.00	4.00	4.20	4.20	4.60	4.60	—
		yd ³	4.97	4.97	5.23	5.23	5.49	5.49	6.02	6.02	—
Capacity — 110%		m ³	4.18	4.18	4.40	4.40	4.62	4.62	5.06	5.06	—
		yd ³	5.47	5.47	5.75	5.75	6.04	6.04	6.62	6.62	—
Width		mm	3220	3271	3220	3271	3220	3271	3220	3271	—
		ft/in	10'6"	10'8"	10'6"	10'8"	10'6"	10'8"	10'6"	10'8"	—
Dump clearance at maximum lift and 45° discharge		mm	3067	2915	3058	2905	2991	2837	2977	2823	558
		ft/in	10'0"	9'6"	10'0"	9'6"	9'9"	9'3"	9'9"	9'3"	1'9"
Reach at maximum lift and 45° discharge		mm	1327	1467	1334	1473	1388	1525	1400	1537	-25
		ft/in	4'4"	4'9"	4'4"	4'10"	4'6"	5'0"	4'7"	5'0"	-1"
Reach at level lift arm and bucket level		mm	2739	2943	2750	2955	2838	3043	2857	3062	404
		ft/in	8'11"	9'7"	9'0"	9'8"	9'3"	9'11"	9'4"	10'0"	1'3"
Digging depth		mm	124	124	124	124	124	124	124	124	-25
		in	4.9	4.9	4.9	4.9	4.9	4.9	4.9	4.9	-1"
Overall length		mm	8681	8906	8693	8918	8780	9005	8799	9024	697
		ft/in	28'6"	29'3"	28'7"	29'4"	28'10"	29'7"	28'11"	29'8"	2'3"
Overall height with bucket at maximum lift		mm	5788	5788	5902	5902	5902	5902	5874	5874	558
		ft/in	19'0"	19'0"	19'5"	19'5"	19'5"	19'5"	19'4"	19'4"	1'9"
Loader clearance circle with bucket at carry position		mm	14 727	14 899	14 733	14 905	14 778	14 951	14 787	14 961	481
		ft/in	48'4"	48'11"	48'5"	48'11"	48'6"	49'1"	48'7"	49'1"	1'6"
Static tipping load, straight (ISO)*		kg	16 045	15 863	16 024	15 842	15 831	15 648	15 822	15 636	372
		lb	35,364	34,963	35,319	34,915	34,893	34,488	34,872	34,463	821
Static tipping load, straight (Rigid Tire)*		kg	17 316	17 131	17 305	17 120	17 104	16 917	17 120	16 931	299
		lb	38,164	37,757	38,141	37,733	37,697	37,287	37,732	37,318	658
Static tipping load, articulated (ISO)*		kg	14 052	13 869	14 028	13 845	13 848	13 664	13 829	13 643	166
		lb	30,971	30,569	30,918	30,514	30,522	30,117	30,479	30,070	366
Static tipping load, articulated (Rigid Tire)*		kg	15 312	15 128	15 298	15 113	15 111	14 925	15 116	14 928	112
		lb	33,749	33,342	33,718	33,309	33,304	32,894	33,316	32,901	248
Breakout force**		kN	187	185	185	183	173	171	170	168	-14
		lbf	42,151	41,781	41,695	41,326	38,984	38,618	38,277	37,912	-3170
Operating weight*		kg	23 073	23 211	23 125	23 263	23 181	23 319	23 221	23 359	1763
		lb	50,853	51,157	50,968	51,272	51,091	51,395	51,179	51,483	3888

*Static tipping loads and operating weights shown are based on standard machine configuration with 26.5R25 L3 Michelin XHA2 radial tires, power train guard, full fuel tank, coolants, lubricants, air conditioner and operator.

Static tipping loads conform to the international standard as defined in ISO 14397-1 (SEPT2007).

**Measured 100 mm (4") behind tip of cutting edge with bucket hinge pin as pivot point in accordance with SAE J732 (APR2007).

NOTE: Specifications and ratings conform to all applicable standards recommended by the Society of Automotive Engineers, including SAE Standard J732 (APR2007) which governs loader ratings.

NOTE: Bucket availability varies by region. Consult your local dealer for availability.

Bucket Type		Rock – Pin On		Material Handling/Standard – Pin On				High Lift Delta
		Bolt-on Cutting Edges	Teeth & Segments	Bolt-on Cutting Edges	Teeth & Segments	Bolt-on Cutting Edges	Teeth & Segments	
Capacity – rated	m ³	3.40	3.40	4.00	4.00	4.60	4.60	—
	yd ³	4.45	4.45	5.23	5.23	6.02	6.02	—
Capacity – 110%	m ³	3.74	3.74	4.40	4.40	5.06	5.06	—
	yd ³	4.89	4.89	5.75	5.75	6.62	6.62	—
Width	mm	3252	3252	3220	3271	3220	3271	—
	ft/in	10'8"	10'8"	10'6"	10'8"	10'6"	10'8"	—
Dump clearance at maximum lift and 45° discharge	mm	3124	3026	2978	2815	2893	2730	558
	ft/in	10'2"	9'11"	9'9"	9'2"	9'5"	8'11"	1'9"
Reach at maximum lift and 45° discharge	mm	1454	1576	1252	1379	1337	1464	-25
	ft/in	4'9"	5'2"	4'1"	4'6"	4'4"	4'9"	-1"
Reach at level lift arm and bucket level	mm	2818	2974	2769	2973	2889	3093	404
	ft/in	9'2"	9'9"	9'1"	9'9"	9'5"	10'1"	1'3"
Digging depth	mm	68	68	124	124	124	124	-25
	in	2.7	2.7	4.9	4.9	4.9	4.9	-1"
Overall length	mm	8745	8906	8711	8936	8831	9056	697
	ft/in	28'9"	29'3"	28'7"	29'4"	29'0"	29'9"	2'3"
Overall height with bucket at maximum lift	mm	5845	5845	5858	5858	5982	5982	558
	ft/in	19'3"	19'3"	19'3"	19'3"	19'8"	19'8"	1'9"
Loader clearance circle with bucket at carry position	mm	14 813	14 901	14 742	14 914	14 804	14 978	481
	ft/in	48'8"	48'11"	48'5"	49'0"	48'7"	49'2"	1'6"
Static tipping load, straight (ISO)*	kg	16 255	16 185	15 834	15 653	15 622	15 438	372
	lb	35,826	35,672	34,899	34,499	34,431	34,026	821
Static tipping load, straight (Rigid Tire)*	kg	17 542	17 471	17 078	16 894	16 885	16 699	299
	lb	38,663	38,507	37,640	37,235	37,216	36,805	658
Static tipping load, articulated (ISO)*	kg	14 217	14 147	13 861	13 680	13 655	13 471	166
	lb	31,334	31,180	30,551	30,151	30,096	29,690	366
Static tipping load, articulated (Rigid Tire)*	kg	15 496	15 425	15 097	14 913	14 909	14 723	112
	lb	34,153	33,998	33,274	32,870	32,861	32,450	248
Breakout force**	kN	186	185	182	181	166	165	-14
	lbf	41,828	41,704	41,111	40,742	37,481	37,117	-3170
Operating weight*	kg	24 004	24 056	23 134	23 272	23 267	23 404	1763
	lb	52,905	53,019	50,987	51,291	51,279	51,583	3888

*Static tipping loads and operating weights shown are based on standard machine configuration with 26.5R25 L3 Michelin XHA2 radial tires, power train guard, full fuel tank, coolants, lubricants, air conditioner and operator.

Static tipping loads conform to the international standard as defined in ISO 14397-1 (SEPT2007).

**Measured 100 mm (4") behind tip of cutting edge with bucket hinge pin as pivot point in accordance with SAE J732 (APR2007).

NOTE: Specifications and ratings conform to all applicable standards recommended by the Society of Automotive Engineers, including SAE Standard J732 (APR2007) which governs loader ratings.

NOTE: Bucket availability varies by region. Consult your local dealer for availability.

Bucket Type		General Purpose – Pin On				Material Handling – Pin On		High Lift Delta
		Bolt-on Cutting Edges	Teeth & Segments	Bolt-on Cutting Edges	Teeth & Segments	Bolt-on Cutting Edges	Teeth & Segments	
Edge Type								
Capacity – rated	m ³	4.20	4.20	4.60	4.60	4.60	4.60	–
	yd ³	5.49	5.49	6.02	6.02	6.02	6.02	–
Capacity – 110%	m ³	4.62	4.62	5.06	5.06	5.06	5.06	–
	yd ³	6.04	6.04	6.62	6.62	6.62	6.62	–
Width	mm	3220	3271	3220	3271	3220	3271	–
	ft/in	10'6"	10'8"	10'6"	10'8"	10'6"	10'8"	–
Dump clearance at maximum lift and 45° discharge	mm	3225	3071	3187	3033	3120	2957	335
	ft/in	10'6"	10'0"	10'5"	9'11"	10'2"	9'8"	1'1"
Reach at maximum lift and 45° discharge	mm	1332	1470	1363	1500	1286	1413	23
	ft/in	4'4"	4'9"	4'5"	4'11"	4'2"	4'7"	0"
Reach at level lift arm and bucket level	mm	2955	3160	3004	3209	3014	3219	273
	ft/in	9'8"	10'4"	9'10"	10'6"	9'10"	10'6"	10"
Digging depth	mm	103	103	103	103	103	103	–4
	in	4.0	4.0	4.0	4.0	4.0	4.0	–0.1
Overall length	mm	9128	9352	9177	9401	9187	9411	336
	ft/in	30'0"	30'9"	30'2"	30'11"	30'2"	30'11"	1'2"
Overall height with bucket at maximum lift	mm	5937	5937	6195	6195	6162	6162	336
	ft/in	19'6"	19'6"	20'4"	20'4"	20'3"	20'3"	1'2"
Loader clearance circle with bucket at carry position	mm	14 925	15 105	14 951	15 133	14 957	15 139	332
	ft/in	49'0"	49'7"	49'1"	49'8"	49'1"	49'8"	1'2"
Static tipping load, straight (ISO)*	kg	18 040	17 857	17 926	17 742	17 868	17 684	–1591
	lb	39,761	39,358	39,510	39,104	39,381	38,976	–3507
Static tipping load, straight (Rigid Tire)*	kg	19 358	19 173	19 254	19 068	19 175	18 989	–1671
	lb	42,666	42,258	42,436	42,026	42,262	41,853	–3683
Static tipping load, articulated (ISO)*	kg	15 675	15 492	15 566	15 382	15 517	15 333	–1438
	lb	34,548	34,144	34,308	33,902	34,200	33,795	–3170
Static tipping load, articulated (Rigid Tire)*	kg	17 013	16 828	16 914	16 728	16 845	16 660	–1530
	lb	37,498	37,090	37,279	36,868	37,128	36,719	–3372
Breakout force**	kN	226	224	218	216	216	215	–6
	lbf	50,833	50,524	49,005	48,696	48,673	48,365	–1424
Operating weight*	kg	25 112	25 250	25 173	25 311	25 168	25 306	85
	lb	55,346	55,650	55,480	55,784	55,469	55,773	186

*Static tipping loads and operating weights shown are based on standard machine configuration with 26.5R25 L3 Michelin XHA2 radial tires, power train guard, full fuel tank, coolants, lubricants, air conditioner and operator.

Static tipping loads conform to the international standard as defined in ISO 14397-1 (SEPT2007).

**Measured 100 mm (4") behind tip of cutting edge with bucket hinge pin as pivot point in accordance with SAE J732 (APR2007).

NOTE: Specifications and ratings conform to all applicable standards recommended by the Society of Automotive Engineers, including SAE Standard J732 (APR2007) which governs loader ratings.

NOTE: Bucket availability varies by region. Consult your local dealer for availability.

Bucket Type		Rock – Pin On		Material Handling/Standard – Pin On				High Lift Delta
		Bolt-on Cutting Edges	Teeth & Segments	Bolt-on Cutting Edges	Teeth & Segments	Bolt-on Cutting Edges	Teeth & Segments	
Capacity – rated	m ³	4.00	4.00	4.60	4.60	5.00	5.00	—
	yd ³	5.23	5.23	6.02	6.02	6.54	6.54	—
Capacity – 110%	m ³	4.40	4.40	5.06	5.06	5.50	5.50	—
	yd ³	5.75	5.75	6.62	6.62	7.19	7.19	—
Width	mm	3252	3252	3220	3271	3220	3271	—
	ft/in	10'8"	10'8"	10'6"	10'8"	10'6"	10'8"	—
Dump clearance at maximum lift and 45° discharge	mm	3233	3142	3120	2957	3070	2908	335
	ft/in	10'7"	10'3"	10'2"	9'8"	10'0"	9'6"	1'1"
Reach at maximum lift and 45° discharge	mm	1463	1571	1286	1413	1335	1462	23
	ft/in	4'9"	5'1"	4'2"	4'7"	4'4"	4'9"	0"
Reach at level lift arm and bucket level	mm	3073	3214	3014	3219	3084	3289	273
	ft/in	10'1"	10'6"	9'10"	10'6"	10'1"	10'9"	10"
Digging depth	mm	44	44	103	103	103	103	-4
	in	1.7	1.7	4.0	4.0	4.0	4.0	-0.1
Overall length	mm	9235	9379	9187	9411	9257	9481	336
	ft/in	30'4"	30'10"	30'2"	30'11"	30'5"	31'2"	1'2"
Overall height with bucket at maximum lift	mm	6159	6159	6162	6162	6223	6223	336
	ft/in	20'3"	20'3"	20'3"	20'3"	20'5"	20'5"	1'2"
Loader clearance circle with bucket at carry position	mm	15 039	15 123	14 957	15 139	14 996	15 178	332
	ft/in	49'5"	49'8"	49'1"	49'8"	49'3"	49'10"	1'2"
Static tipping load, straight (ISO)*	kg	18 511	18 441	17 888	17 703	17 758	17 573	-1591
	lb	40,798	40,644	39,425	39,019	39,139	38,731	-3507
Static tipping load, straight (Rigid Tire)*	kg	19 876	19 806	19 195	19 009	19 078	18 891	-1671
	lb	43,808	43,652	42,306	41,895	42,049	41,636	-3683
Static tipping load, articulated (ISO)*	kg	16 080	16 009	15 537	15 353	15 410	15 225	-1438
	lb	35,440	35,285	34,244	33,838	33,965	33,556	-3170
Static tipping load, articulated (Rigid Tire)*	kg	17 467	17 396	16 865	16 679	16 752	16 564	-1530
	lb	38,498	38,342	37,172	36,761	36,921	36,508	-3372
Breakout force**	kN	220	220	216	215	206	204	-6
	lbf	49,563	49,451	48,687	48,377	46,309	46,001	-1424
Operating weight*	kg	25 969	26 020	25 146	25 284	25 230	25 368	85
	lb	57,236	57,348	55,422	55,726	55,607	55,911	186

*Static tipping loads and operating weights shown are based on standard machine configuration with 26.5R25 L3 Michelin XHA2 radial tires, power train guard, full fuel tank, coolants, lubricants, air conditioner and operator.

Static tipping loads conform to the international standard as defined in ISO 14397-1 (SEPT2007).

**Measured 100 mm (4") behind tip of cutting edge with bucket hinge pin as pivot point in accordance with SAE J732 (APR2007).

NOTE: Specifications and ratings conform to all applicable standards recommended by the Society of Automotive Engineers, including SAE Standard J732 (APR2007) which governs loader ratings.

NOTE: Bucket availability varies by region. Consult your local dealer for availability.

Bucket Type	General Purpose – Pin On						High Lift Delta	
	Bolt-on Cutting Edges	Teeth & Segments	Bolt-on Cutting Edges	Teeth & Segments	Bolt-on Cutting Edges	Teeth & Segments		
Edge Type								
Capacity – rated	m ³	5.40	5.40	5.70	5.70	6.00	6.00	—
	yd ³	7.06	7.06	7.46	7.46	7.85	7.85	—
Capacity – 110%	m ³	5.94	5.94	6.27	6.27	6.60	6.60	—
	yd ³	7.77	7.77	8.20	8.20	8.63	8.63	—
Width	mm	3447	3535	3447	3535	3447	3535	—
	ft/in	11'3"	11'7"	11'3"	11'7"	11'3"	11'7"	—
Dump clearance at maximum lift and 45° discharge	mm	3242	3077	3174	3007	3156	2989	220
	ft/in	10'7"	10'1"	10'4"	9'10"	10'4"	9'9"	8"
Reach at maximum lift and 45° discharge	mm	1580	1717	1628	1762	1649	1784	2
	ft/in	5'2"	5'7"	5'4"	5'9"	5'4"	5'10"	0"
Reach at level lift arm and bucket level	mm	3064	3276	3148	3360	3176	3388	160
	ft/in	10'0"	10'8"	10'3"	11'0"	10'5"	11'1"	6"
Digging depth	mm	133	133	133	133	133	133	-1
	in	5.2	5.2	5.2	5.2	5.2	5.2	-0
Overall length	mm	9637	9878	9721	9962	9749	9990	200
	ft/in	31'8"	32'5"	31'11"	32'9"	32'0"	32'10"	8"
Overall height with bucket at maximum lift	mm	6391	6391	6213	6213	6239	6239	221
	ft/in	21'0"	21'0"	20'5"	20'5"	20'6"	20'6"	9"
Loader clearance circle with bucket at carry position	mm	15 857	16 080	15 902	16 125	15 917	16 141	175
	ft/in	52'1"	52'10"	52'3"	52'11"	52'3"	53'0"	7"
Static tipping load, straight (ISO)*	kg	20 504	20 322	20 272	20 089	20 136	19 952	-1720
	lb	45,192	44,790	44,681	44,277	44,379	43,974	-3792
Static tipping load, straight (Rigid Tire)*	kg	22 086	21 900	21 855	21 667	21 719	21 531	-1950
	lb	48,678	48,268	48,168	47,755	47,870	47,456	-4299
Static tipping load, articulated (ISO)*	kg	17 895	17 710	17 677	17 492	17 544	17 358	-1550
	lb	39,441	39,035	38,961	38,552	38,667	38,257	-3416
Static tipping load, articulated (Rigid Tire)*	kg	19 764	19 578	19 546	19 358	19 414	19 226	-1787
	lb	43,561	43,150	43,079	42,666	42,789	42,375	-3939
Breakout force**	kN	201	199	190	188	186	184	3
	lbf	45,379	44,838	42,792	42,264	41,931	41,407	719
Operating weight*	kg	29 945	30 084	30 028	30 167	30 124	30 263	115
	lb	65,999	66,304	66,182	66,487	66,393	66,698	253

*Static tipping loads and operating weights shown are based on standard machine configuration with 29.5R25, L3 Michelin XHA2 radial tires, power train guard, full fuel tank, coolant, lubricants, air conditioner and operator.

Static tipping loads conform to the international standard as defined in ISO 14397-1 (SEPT2007).

**Measured 100 mm (4") behind tip of cutting edge with bucket hinge pin as pivot point in accordance with SAE J732 (APR2007).

NOTE: Specifications and ratings conform to all applicable standards recommended by the Society of Automotive Engineers, including SAE Standard J732 (APR2007) which governs loader ratings.

NOTE: Bucket availability varies by region. Consult your local dealer for availability.

Wheel Loaders Integrated Toolcarriers

Performance Data ● 980H

Bucket Type		Material Handling – Pin On		Rock – Pin On		Coal – Pin On	General Purpose/ Heavy Duty – Pin On		High Lift Delta
		Bolt-on Cutting Edges	Teeth & Segments	Bolt-on Cutting Edges	Teeth & Segments	Bolt-on Cutting Edges	Bolt-on Cutting Edges	Teeth & Segments	
Capacity – rated	m ³	5.70	5.70	4.40	4.40	8.20	5.70	5.70	–
	yd ³	7.46	7.46	5.75	5.75	10.73	7.46	7.46	–
Capacity – 110%	m ³	6.27	6.27	4.84	4.84	9.02	6.27	6.27	–
	yd ³	8.20	8.20	6.33	6.33	11.80	8.20	8.20	–
Width	mm	3447	3535	3504	3504	3638	3447	3535	–
	ft/in	11'3"	11'7"	11'5"	11'5"	11'11"	11'3"	11'7"	–
Dump clearance at maximum lift and 45° discharge	mm	3075	2898	3101	3101	2887	3174	3007	220
	ft/in	10'1"	9'6"	10'2"	10'2"	9'5"	10'4"	9'10"	8"
Reach at maximum lift and 45° discharge	mm	1543	1665	1844	1844	1724	1628	1762	2
	ft/in	5'0"	5'5"	6'0"	6'0"	5'7"	5'4"	5'9"	0"
Reach at level lift arm and bucket level	mm	3173	3385	3360	3360	3435	3148	3360	160
	ft/in	10'4"	11'1"	11'0"	11'0"	11'3"	10'3"	11'0"	6"
Digging depth	mm	133	133	106	106	138	133	133	–1
	in	5.2	5.2	4.1	4.1	5.4	5.2	5.2	–0
Overall length	mm	9746	9987	9949	9949	10 011	9721	9962	200
	ft/in	32'0"	32'10"	32'8"	32'8"	32'11"	31'11"	32'9"	8"
Overall height with bucket at maximum lift	mm	6212	6212	6184	6184	6506	6213	6213	221
	ft/in	20'5"	20'5"	20'4"	20'4"	21'5"	20'5"	20'5"	9"
Loader clearance circle with bucket at carry position	mm	15 916	16 139	16 094	16 093	16 236	15 902	16 125	175
	ft/in	52'3"	53'0"	52'10"	52'10"	53'4"	52'3"	52'11"	7"
Static tipping load, straight (ISO)*	kg	19 825	19 643	21 253	21 285	19 512	20 116	19 932	–1720
	lb	43,694	43,295	46,843	46,913	43,006	44,336	43,932	–3792
Static tipping load, straight (Rigid Tire)*	kg	21 360	21 175	22 897	22 940	21 151	21 694	21 507	–1950
	lb	47,078	46,670	50,466	50,560	46,616	47,815	47,402	–4299
Static tipping load, articulated (ISO)*	kg	17 271	17 088	18 537	18 550	16 932	17 519	17 334	–1550
	lb	38,067	37,663	40,857	40,884	37,318	38,613	38,204	–3416
Static tipping load, articulated (Rigid Tire)*	kg	19 091	18 906	20 482	20 509	18 854	19 385	19 198	–1787
	lb	42,078	41,670	45,144	45,202	41,556	42,726	42,313	–3939
Breakout force**	kN	187	184	190	189	157	189	187	3
	lbf	42,029	41,504	42,739	42,551	35,358	42,665	42,136	719
Operating weight*	kg	30 153	30 292	31 109	31 184	30 532	30 175	30 313	115
	lb	66,457	66,762	68,564	68,730	67,293	66,504	66,809	253

*Static tipping loads and operating weights shown are based on standard machine configuration with 29.5R25, L3 Michelin XHA2 radial tires, power train guard, full fuel tank, coolant, lubricants, air conditioner and operator.

Static tipping loads conform to the international standard as defined in ISO 14397-1 (SEPT2007).

**Measured 100 mm (4") behind tip of cutting edge with bucket hinge pin as pivot point in accordance with SAE J732 (APR2007).

NOTE: Specifications and ratings conform to all applicable standards recommended by the Society of Automotive Engineers, including SAE Standard J732 (APR2007) which governs loader ratings.

NOTE: Bucket availability varies by region. Consult your local dealer for availability.

Bucket Type		Rock — Pin On					Rock/ Heavy Duty/Extra Wide Bucket — Pin On	High Lift Delta
		Teeth & Segments + Side Protector	Teeth + Side Protector	Teeth & Segments + Side Protector	Teeth + Side Protector	Teeth + Side Protector	Teeth & Segments + Side Protector	
Edge Type								
Capacity — rated	m ³ yd ³	4.48 5.86	4.31 5.64	5.66 7.40	5.38 7.03	5.38 7.03	5.41 7.07	— —
Capacity — 110%	m ³ yd ³	4.93 6.45	4.75 6.21	6.22 8.14	5.91 7.74	5.91 7.74	5.95 7.78	— —
Width	mm ft/in	3504 11'5"	3504 11'5"	3504 11'5"	3504 11'5"	3510 11'6"	3645 11'11"	— —
Dump clearance at maximum lift and 45° discharge	mm ft/in	3051 10'0"	3051 10'0"	2890 9'5"	2890 9'5"	2983 9'9"	2941 9'7"	220 8"
Reach at maximum lift and 45° discharge	mm ft/in	1788 5'10"	1788 5'10"	1979 6'5"	1979 6'5"	1930 6'4"	1965 6'5"	2 0"
Reach at level lift arm and bucket level	mm ft/in	3359 11'0"	3359 11'0"	3608 11'10"	3608 11'10"	3512 11'6"	3561 11'8"	160 6"
Digging depth	mm in	106 4.1	71 2.8	106 4.1	71 2.8	77 3.0	77 3.0	-1 -0
Overall length	mm ft/in	9948 32'8"	9948 32'8"	10 197 33'6"	10 197 33'6"	10 069 33'1"	10 156 33'4"	200 8"
Overall height with bucket at maximum lift	mm ft/in	6204 20'5"	6204 20'5"	6378 21'0"	6378 21'0"	6378 21'0"	6378 21'0"	221 9"
Loader clearance circle with bucket at carry position	mm ft/in	16 093 52'10"	16 093 52'10"	16 235 53'4"	16 235 53'4"	16 156 53'1"	16 340 53'8"	175 7"
Static tipping load, straight (ISO)*	kg lb	20 998 46,279	21 519 47,428	20 119 44,343	20 693 45,607	20 705 45,635	19 813 43,669	-1720 -3792
Static tipping load, straight (Rigid Tire)*	kg lb	22 649 49,918	23 190 51,112	21 764 47,968	22 361 49,285	22 374 49,313	21 461 47,301	-1950 -4299
Static tipping load, articulated (ISO)*	kg lb	18 265 40,257	18 775 41,381	17 439 38,436	17 995 39,663	18 008 39,690	17 091 37,669	-1550 -3416
Static tipping load, articulated (Rigid Tire)*	kg lb	20 223 44,572	20 750 45,733	19 387 42,730	19 965 44,003	19 977 44,031	19 053 41,993	-1787 -3939
Breakout force**	kN lbf	188 42,289	204 45,879	159 35,932	172 38,725	184 41,402	173 38,896	3 719
Operating weight*	kg lb	31 475 69,370	31 175 68,709	31 821 70,132	31 521 69,471	31 517 69,463	32 239 71,055	115 253

*Static tipping loads and operating weights shown are based on standard machine configuration with 29.5R25, L3 Michelin XHA2 radial tires, power train guard, full fuel tank, coolant, lubricants, air conditioner and operator.

Static tipping loads conform to the international standard as defined in ISO 14397-1 (SEPT2007).

**Measured 100 mm (4") behind tip of cutting edge with bucket hinge pin as pivot point in accordance with SAE J732 (APR2007).

NOTE: Specifications and ratings conform to all applicable standards recommended by the Society of Automotive Engineers, including SAE Standard J732 (APR2007) which governs loader ratings.

NOTE: Bucket availability varies by region. Consult your local dealer for availability.

Bucket Type	Standard Lift			High Lift				
	Rock Teeth & Segments	Rock Teeth & Segments	Rock Teeth & Segments	Rock Teeth & Segments	Rock Teeth & Segments	Rock Teeth & Segments		
Cutting Edge Type	Spade	Spade	Spade	Spade	Spade	Spade		
Bucket Part Number	369-2020	369-2030	369-2040	369-2020	369-2030	369-2040		
Capacity — struck	m ³	4.4	4.8	5.1	4.4	4.8	5.1	
	yd ³	5.8	6.2	6.7	5.8	6.2	6.7	
Heaped capacity — rated	m ³	5.4	5.7	6.1	5.4	5.7	6.1	
	yd ³	7.0	7.5	8.0	7.0	7.5	8.0	
Width	mm	3772	3772	3772	3772	3772	3772	
	ft	12.4	12.4	12.4	12.4	12.4	12.4	
Dump clearance at full lift and 45° discharge	Edge	mm	3420	3374	3328	3879	3833	3787
		ft	11.2	11.1	10.9	12.7	12.6	12.4
	With Teeth	mm	3280	3234	3188	3739	3693	3647
		ft	10.8	10.6	10.5	12.3	12.1	12.0
Reach at lift and 45° discharge	Edge	mm	1858	1904	1950	1798	1840	1882
		ft	6.1	6.2	6.4	5.9	6.0	6.2
	With Teeth	mm	1976	2022	2068	1904	1946	1988
		ft	6.5	6.6	6.8	6.2	6.4	6.5
Reach with lift arms horizontal and bucket level	mm	3657	3722	3787	4021	4086	4151	
	ft	12.0	12.2	12.4	13.2	13.4	13.6	
Digging depth	mm	160	160	160	208	208	208	
	in	6.3	6.3	6.3	8.2	8.2	8.2	
Overall length	mm	10 842	10 907	10 972	11 290	11 355	11 420	
	ft	35.6	35.8	36.0	37.0	37.3	37.5	
Overall height with bucket at full raise	mm	6609	6671	6734	7067	7130	7193	
	ft	21.7	21.9	22.1	23.2	23.4	23.6	
Loader clearance turning circle — SAE carry with teeth	mm	17 215	17 248	17 281	17 612	17 648	17 684	
	ft	56.5	56.6	56.7	57.8	57.9	58.0	
Full dump angle	degrees	-50	-50	-50	-50	-50	-50	
Static tipping load — straight**	kg	29 147	28 969	28 791	24 759	24 595	24 431	
	lb	64,259	63,867	63,472	54,584	54,224	53,862	
Static tipping load — straight*	kg	27 698	27 509	27 319	23 632	23 458	23 284	
	lb	61,064	60,647	60,228	52,100	51,716	51,332	
Static tipping load — full turn (articulated 35°)**	kg	25 845	25 673	25 501	21 845	21 686	21 527	
	lb	56,979	56,600	56,220	48,159	47,809	47,458	
Static tipping load — full turn (articulated 35°)*	kg	23 846	23 661	23 476	20 251	20 081	19 911	
	lb	52,571	52,164	51,756	44,646	44,271	43,896	
Breakout force	kN	356	341	328	355	341	328	
	lbf	79,945	76,722	73,722	79,869	76,650	73,652	
Operating weight	kg	42 011	42 118	42 225	42 836	42 943	43 050	
	lb	92,618	92,855	93,090	94,437	94,673	94,909	
Weight distribution at SAE carry — unloaded	Front	kg	20 493	20 689	20 885	22 262	22 472	22 680
		lb	45,178	45,612	46,044	49,079	49,541	50,002
	Rear	kg	21 518	21 429	21 340	20 574	20 472	20 370
		lb	47,439	47,242	47,046	45,358	45,132	44,907
Weight distribution at SAE carry — loaded	Front	kg	37 109	37 340	37 571	38 451	38 691	38 931
		lb	81,811	82,320	82,830	84,769	85,299	85,828
	Rear	kg	14 902	14 778	14 654	13 457	13 324	13 191
		lb	32,853	32,580	32,307	29,668	29,375	29,081

*Tipping Load is calculated with tire squash.

**Tipping Load is calculated without tire squash.

Bucket Type		Standard Lift Aggregate Package					
		General Purpose	General Purpose	General Purpose	General Purpose	Coal	
Ground Engaging Tools		Segments	Segments	Segments	Segments	Segments	
Cutting Edge Type		Straight	Straight	Straight	Straight	Straight	
Bucket Part Number		436-8310	436-8320	436-8330	477-1900	436-8340	
Capacity — struck	m ³	5.2	5.9	6.6	7.3	9.0	
	yd ³	6.8	7.7	8.6	9.6	11.8	
Heaped capacity — rated	m ³	6.1	6.9	7.7	8.4	10.3	
	yd ³	8.0	9.0	10.0	11.0	13.5	
Width	mm	3687	3687	3687	3729	3729	
	ft	12.1	12.1	12.1	12.2	12.2	
Dump clearance at full lift and 45° discharge (edge)	mm	3560	3471	3386	3222	3266	
	ft	11.7	11.4	11.1	10.6	10.7	
Reach at lift and 45° discharge (edge)	mm	1743	1831	1917	2081	2012	
	ft	5.7	6.0	6.3	6.8	6.6	
Reach with lift arms horizontal and bucket level	mm	3294	3419	3540	3772	3692	
	ft	10.8	11.2	11.6	12.4	12.1	
Digging depth	mm	143	143	143	143	160	
	in	0.5	0.5	0.5	0.5	0.5	
Overall length	mm	10 487	10 612	10 733	10 965	10 899	
	ft	34.4	34.8	35.2	36.0	35.8	
Overall height with bucket at full raise	mm	6844	6965	7063	7000	7394	
	ft	22.5	22.9	23.2	23.0	24.3	
Loader clearance turning circle — SAE carry with teeth	mm	17 273	17 336	17 398	17 521	17 542	
	ft	56.7	56.9	57.1	57.5	57.6	
Full dump angle	degrees	-50	-50	-50	-50	-50	
Static tipping load — straight**	kg	34 164	33 787	33 420	32 625	33 128	
	lb	75,318	74,488	73,677	71,926	73,036	
Static tipping load — straight*	kg	32 318	31 919	31 531	30 751	31 068	
	lb	71,249	70,369	69,514	67,794	68,493	
Static tipping load — full turn (articulated 35°)**	kg	30 271	29 910	29 558	28 808	29 245	
	lb	66,737	65,940	65,164	63,510	64,473	
Static tipping load — full turn (articulated 35°)*	kg	27 633	27 244	26 866	26 134	26 341	
	lb	60,920	60,063	59,229	57,616	58,072	
Breakout force	kN	400	367	340	297	307	
	lbf	89,924	82,515	76,334	66,675	69,100	
Operating weight	kg	45 665	45 877	46 084	46 376	46 606	
	lb	100,675	101,142	101,597	102,242	102,749	
Weight distribution at SAE carry — unloaded	Front	kg	20 525	20 909	21 283	21 875	22 219
		lb	45,249	46,096	46,921	48,226	48,984
	Rear	kg	25 141	24 969	24 801	24 501	24 388
		lb	55,425	55,046	54,676	54,015	53,765
Weight distribution at SAE carry — loaded	Front	kg	41 648	42 118	42 577	43 323	37 678
		lb	91,817	92,853	93,865	95,510	83,065
	Rear	kg	16 719	16 461	16 208	15 755	18 000
		lb	36,858	36,290	35,733	34,733	39,684

*Tipping Load is calculated with tire squash.
**Tipping Load is calculated without tire squash.

Bucket Type		988K HL Tires: 35/65 R33 XLDD1 PN: 339-8790 SLR: 978 mm						
		Standard Lift						
		General Purpose		Rock			Heavy Duty Rock	
Ground Engaging Tools		Adapters or BOCE	Adapters or BOCE	K130	K131	K132	K133	
Cutting Edge Type		Straight	Straight	Spade	Spade	Spade	Spade	
Bucket Part Number		347-4990	347-4980	347-4960	347-4950	347-4970	339-1370	
Struck capacity	m ³	6.0	5.5	6.5	5.5	5.0	5.0	
	yd ³	7.8	7.2	8.5	7.2	6.5	6.5	
Heaped capacity — rated	m ³	7.6	6.9	7.6	6.9	6.4	6.4	
	yd ³	10.0	9.0	10.0	9.0	8.3	8.3	
Bucket width	mm	3897	3897	4020	4020	4020	4080	
	ft	12.8	12.8	13.2	13.2	13.2	13.4	
Dump clearance at full lift and 45° discharge	Bare	mm	3810	3894	3595	3807	3728	3714
		ft	12.5	12.8	11.8	12.5	12.2	12.2
	With teeth	mm	3810	3894	3402	3445	3535	3509
		ft	12.5	12.8	11.2	11.3	11.6	11.5
Reach at lift and 45° discharge	Bare	mm	1730	1653	1944	1778	1811	1824
		ft	5.7	5.4	6.4	5.8	5.9	6.0
	With teeth	mm	1730	1653	2127	2074	1994	1998
		ft	5.7	5.4	7.0	6.8	6.5	6.6
Reach with lift arms horizontal and bucket level — teeth	mm	3668	3554	4237	4144	4049	4071	
	ft	12.0	11.7	13.9	13.6	13.3	13.4	
Digging depth — segment	mm	203	198	204	204	204	204	
	in	8.0	8.0	8.0	8.0	8.0	8.0	
Overall length bucket level ground	mm	11 716	11 598	12 286	12 204	12 098	12 119	
	ft	38.4	38.1	40.3	40.0	39.7	39.8	
Overall height with bucket at full raise	mm	7583	7479	7549	7447	7373	7376	
	ft	24.9	24.5	24.8	24.4	24.2	24.2	
Loader clearance turning circle — SAE carry with teeth	mm	17 240	17 173	17 400	17 338	17 295	17 317	
	ft	56.6	56.3	57.1	56.9	56.7	56.8	
Full dump angle	degrees	51	51	51	51	51	51	
Static tipping load — straight*	kg	34 768	35 148	33 811	34 249	34 390	33 331	
	lb	76,650	77,488	74,541	75,506	75,817	73,483	
Static tipping load — full turn (articulated 35°)*	kg	31 139	31 508	30 196	30 625	30 760	29 703	
	lb	68,649	69,462	66,571	67,517	67,815	65,484	
Static tipping load — full turn (articulated 43°)*	kg	29 377	29 740	28 441	28 866	28 998	27 941	
	lb	64,765	65,566	62,701	63,638	63,930	61,600	
Breakout force	kN	437	468	371	392	410	402	
	lbf	98,316	105,297	83,330	88,207	92,170	90,383	
Operating weight	kg	50 306	50 065	50 873	50 530	50 502	51 481	
	lb	110,905	110,375	112,155	111,399	111,337	113,496	
Weight distribution at SAE carry — unloaded	Front	kg	27 450	27 034	28 538	27 979	27 880	29 476
		lb	60,516	59,600	62,916	61,683	61,465	64,982
	Rear	kg	22 856	23 031	22 335	22 551	22 622	22 005
		lb	50,388	50,775	49,239	49,716	49,873	48,514
Weight distribution at SAE carry — loaded	Front	kg	45 653	45 177	46 776	46 164	46 028	47 629
		lb	100,649	99,599	103,123	101,773	101,474	105,003
	Rear	kg	15 992	16 228	15 437	15 706	15 814	15 192
		lb	35,257	35,777	34,032	34,627	34,864	33,493

Tire spec used for Tipping Load specifications includes 35-65R33 (L-4) Michelin XLDD1 tires.

*Tipping Load is calculated without tire squash.

988K HL Tires: 35/65 R33 XLDD1 PN: 339-8790 SLR: 978 mm								
High Lift								
Bucket Type	General Purpose		Rock			Heavy Duty Rock		
	Adapters or BOCE	Adapters or BOCE	K130	K131	K132	K133		
Ground Engaging Tools	Straight		Spade	Spade	Spade	Spade		
Cutting Edge Type	Straight		Spade	Spade	Spade	Spade		
Bucket Part Number	347-4990	347-4980	347-4960	347-4950	347-4970	339-1370		
Struck capacity	m ³	6.0	5.5	6.5	5.5	5.0	5.0	
	yd ³	7.8	7.2	8.5	7.2	6.5	6.5	
Heaped capacity — rated	m ³	7.6	6.9	7.6	6.9	6.4	6.4	
	yd ³	10.0	9.0	10.0	9.0	8.3	8.3	
Bucket width	mm	3897	3897	4020	4020	4020	4080	
	ft	12.8	12.8	13.2	13.2	13.2	13.4	
Dump clearance at full lift and 45° discharge	Bare	mm	4211	4296	3997	4074	4130	4116
		ft	13.8	14.1	13.1	13.4	13.5	13.5
	With teeth	mm	4211	4296	3804	3882	3937	3911
		ft	13.8	14.1	12.5	12.7	12.9	12.8
Reach at lift and 45° discharge	Bare	mm	1811	1734	2024	1947	1892	1905
		ft	5.9	5.7	6.6	6.4	6.2	6.2
	With teeth	mm	1811	1734	2208	2130	2075	2079
		ft	5.9	5.7	7.2	7.0	6.8	6.8
Reach with lift arms horizontal and bucket level — teeth	mm	4007	3893	4576	4466	4388	4410	
	ft	13.1	12.8	15.0	14.7	14.4	14.5	
Digging depth — segment	mm	219	214	220	220	220	220	
	in	9.0	8.0	9.0	9.0	9.0	9.0	
Overall length bucket level ground	mm	12 122	12 005	12 692	12 582	12 504	12 525	
	ft	39.8	39.4	41.6	41.3	41.0	41.1	
Overall height with bucket at full raise	mm	7985	7881	7951	7849	7775	7778	
	ft	26.2	25.9	26.1	25.7	25.5	25.5	
Loader clearance turning circle — SAE carry with teeth	mm	17 595	17 525	17 755	17 691	17 647	17 671	
	ft	57.7	57.5	58.3	58.0	57.9	58.0	
Full dump angle	degrees	-50	-50	-50	-50	-50	-50	
Static tipping load — straight*	kg	32 742	33 084	31 833	32 240	32 352	31 299	
	lb	72,183	72,937	70,179	71,077	71,325	69,003	
Static tipping load — full turn (articulated 35°)*	kg	29 193	29 527	28 296	28 698	28 806	27 754	
	lb	64,360	65,096	62,383	63,268	63,507	61,188	
Static tipping load — full turn (articulated 43°)*	kg	27 470	27 801	26 580	26 978	27 085	26 033	
	lb	60,562	61,290	58,598	59,477	59,712	57,394	
Breakout force	kN	403	431	341	361	377	370	
	lbf	90,535	97,001	76,634	81,154	84,841	83,123	
Operating weight	kg	51 648	51 408	52 216	51 873	51 845	52 824	
	lb	113,865	113,335	115,116	114,359	114,298	116,456	
Weight distribution at SAE carry — unloaded	Front	kg	27 950	27 515	29 086	28 497	28 398	30 082
		lb	61,619	60,660	64,124	62,826	62,608	66,320
	Rear	kg	23 698	23 893	23 129	23 375	23 446	22 742
		lb	52,246	52,675	50,991	51,534	51,690	50,137
Weight distribution at SAE carry — loaded	Front	kg	47 141	46 651	48 312	47 674	47 542	49 232
		lb	103,928	102,848	106,509	105,104	104,813	108,538
	Rear	kg	15 847	16 097	15 244	15 538	15 642	14 931
		lb	34,937	35,487	33,607	34,256	34,485	32,918

Tire spec used for Tipping Load specifications includes 35-65R33 (L-4) Michelin XLDD1 tires.

*Tipping Load is calculated without tire squash.

Wheel Loaders Integrated Toolcarriers

Performance Data ● 988K Aggregate Package

			988K Standard Lift Tires: 35/65 R33 XLDD1, PN: 339-8790, SLR: 978 mm			
			Standard Lift Aggregate Package			
			General Purpose			
Bucket Type			Adapters or BOCE	Adapters or BOCE	Adapters or BOCE	Adapters or BOCE
Ground Engaging Tools			Straight	Straight	Straight	Straight
Cutting Edge Type			472-0120	435-4029	347-4990	347-4980
Bucket Part Number						
Struck capacity	m ³		8.0	7.0	6.0	5.5
		yd ³	10.5	9.2	7.8	7.2
Heaped capacity — rated	m ³		9.6	8.4	7.6	6.9
		yd ³	12.5	11.0	10.0	9.0
Bucket width	mm		3897	3897	3897	3897
		ft	12.8	12.8	12.8	12.8
Dump clearance at full lift and 45° discharge (bare)	mm		3642	3741	3818	3902
		ft	11.9	12.3	12.5	12.8
Reach at lift and 45° discharge (bare)	mm		1898	1787	1722	1645
		ft	6.2	5.9	5.7	5.4
Digging depth — segment	mm		200	208	200	195
		in	7.9	8.2	7.9	7.7
Overall length bucket level ground	mm		11 965	11 822	11 716	11 598
		ft	39.3	38.8	38.4	38.1
Overall height with bucket at full raise	mm		7830	7688	7591	7487
		ft	25.7	25.2	24.9	24.6
Loader clearance turning circle — SAE carry bare	mm		17 382	17 303	17 240	17 173
		ft	57.0	56.8	56.6	56.3
Full dump angle	degrees		-49.8	-49.8	-49.8	-49.8
Static tipping load — straight (rigid tire)	kg		39 436	39 922	40 321	40 726
		lb	86,941	88,013	88,892	89,785
Static tipping load — straight (tire squash)	kg		37 085	37 603	38 008	38 428
		lb	81,758	82,900	83,793	84,719
Static tipping load — full turn (articulated 35°) (rigid tire)	kg		35 173	35 641	36 031	36 423
		lb	77,543	78,575	79,435	80,299
Static tipping load — full turn (articulated 35°) (tire squash)	kg		31 461	31 981	32 383	32 799
		lb	69,360	70,506	71,392	72,309
Static tipping load — full turn (articulated 43°) (rigid tire)	kg		33 104	33 563	33 949	34 334
		lb	72,982	73,994	74,845	75,693
Static tipping load — full turn (articulated 43°) (tire squash)	kg		29 003	29 519	29 918	30 327
		lb	63,941	65,078	65,958	66,860
Breakout force	kN		381	413	437	468
		lbf	85,652	92,846	98,241	105,211
Operating weight	kg		53 379	53 104	52 816	52 576
		lb	117,681	117,074	116,439	115,909
Weight distribution at SAE carry — unloaded	Front	kg	27 257	26 781	26 290	25 875
		lb	60,090	59,042	57,960	57,044
	Rear	kg	26 123	26 323	26 526	26 701
		lb	57,591	58,033	58,479	58,865
Weight distribution at SAE carry — loaded	Front	kg	50 724	50 137	49 596	49 103
		lb	111,828	110,533	109,341	108,253
	Rear	kg	17 170	17 482	17 735	17 988
		lb	37,853	38,542	39,098	39,656

Tire spec used for Tipping Load specifications includes 35-65R33 (L-4) Michelin XLDD1 tires.

			990K STD Tires: 45/65R39 VSDL SLR: 1203 mm			
			Standard Lift			
Bucket Type			Rock			Heavy Duty
Ground Engaging Tools			Teeth & Segments	Teeth & Segments	Teeth & Segments	Teeth & Segments
Cutting Edge Type			Spade	Spade	Spade	Spade
Bucket Part Number			361-6110	361-6120	361-6140	361-6150
Struck capacity		m ³	7.0	7.5	8.0	7.0
		yd ³	9.1	9.9	10.5	9.1
Heaped capacity — rated		m ³	8.6	9.2	10.0	8.6
		yd ³	11.25	12.0	13.0	11.25
Bucket width		mm	4610	4610	4610	4610
		ft	15.1	15.1	15.1	15.1
Dump clearance at full lift and 45° discharge	Bare	mm	4234	4186	4106	4217
		ft	13.9	13.7	13.5	13.8
	With teeth	mm	4060	4012	3932	4014
		ft	13.3	13.2	12.9	13.2
Reach at lift and 45° discharge	Bare	mm	2027	2074	2138	2027
		ft	6.6	6.8	7.0	6.6
	With teeth	mm	2194	2241	2305	2188
		ft	7.2	7.4	7.6	7.2
Reach with lift arms horizontal and bucket level — teeth		mm	4331	4398	4488	4347
		ft	14.2	14.4	14.7	14.3
Digging depth — segment		mm	113	113	113	113
		in	4.5	4.5	4.5	4.5
Overall length — bucket level ground		mm	13 072	13 139	13 229	13 088
		ft	42.9	43.1	43.4	42.9
Overall height with bucket at full raise		mm	8293	8359	8359	8293
		ft	27.2	27.4	27.4	27.2
Loader clearance turning circle — SAE carry with teeth		mm	20 863	20 898	20 946	20 969
		ft	68.4	68.6	68.7	68.8
Full dump angle		degrees	-45	-45	-45	-45
Static tipping load — straight*		kg	49 513	49 233	49 280	47 872
		lb	109,158	108,540	108,644	105,540
Static tipping load — full turn (articulated 35°)*		kg	44 180	43 908	43 934	42 537
		lb	94,401	96,801	96,858	93,778
Breakout force		kN	590	570	546	584
		lbf	132,617	128,103	122,733	131,034
Operating weight		kg	80 974	81 147	81 299	82 511
		lb	178,517	178,899	179,233	181,906
Weight distribution at SAE carry — unloaded	Front	kg	44 827	45 142	45 396	47 414
		lb	98,827	99,522	100,080	104,529
	Rear	kg	36 147	36 005	35 903	35 097
		lb	79,690	79,377	79,153	77,377
Weight distribution at SAE carry — loaded	Front	kg	70 939	71 103	71 536	73 510
		lb	156,395	157,197	157,710	162,062
	Rear	kg	25 909	25 719	25 638	24 876
		lb	57,120	56,700	56,521	54,842

*Tipping Load is calculated without tire squash.

			990K STD Tires: 45/65R39 VSDL SLR: 1203 mm			
			High Lift			
Bucket Type			Rock		Heavy Duty	
Ground Engaging Tools			Teeth & Segments	Teeth & Segments	Teeth & Segments	Teeth & Segments
Cutting Edge Type			Spade	Spade	Spade	Spade
Bucket Part Number			361-6110	361-6120	361-6140	361-6150
Struck capacity		m ³	7.0	7.5	8.0	7.0
		yd ³	9.1	9.9	10.5	9.1
Heaped capacity — rated		m ³	8.6	9.2	10	8.6
		yd ³	11.25	12	13	11.25
Bucket width		mm	4610	4610	4610	4610
		ft	15.1	15.1	15.1	15.1
Dump clearance at full lift and 45° discharge	Bare	mm	4895	4647	4585	4695
		ft	15.4	15.2	15.0	15.4
	With teeth	mm	4521	4473	4410	4492
		ft	14.8	14.7	14.5	14.7
Reach at lift and 45° discharge	Bare	mm	2416	2463	2527	2416
		ft	7.9	8.1	8.3	7.9
	With teeth	mm	2583	2630	2694	2578
		ft	8.5	8.6	8.8	8.5
Reach with lift arms horizontal and bucket level — teeth		mm	4931	4998	5088	4947
		ft	16.2	16.4	16.7	16.2
Digging depth		mm	155	155	155	155
		in	6.1	6.1	6.1	6.1
Overall length		mm	13 811	13 878	13 968	13 827
		ft	45.3	45.5	45.8	45.4
Overall height with bucket at full raise		mm	8754	8820	8820	8754
		ft	28.7	28.9	28.9	28.7
Loader clearance turning circle — SAE carry with teeth		mm	21 848	21 890	21 947	21 622
		ft	71.1	71.8	72.0	70.9
Full dump angle		degrees	-51	-51	-51	-51
Static tipping load — straight*		kg	45 117	44 834	44 814	43 510
		lb	99,465	98,842	98,798	95,924
Static tipping load — full turn (articulated 35°)*		kg	39 904	39 631	39 596	38 295
		lb	87,974	87,372	87,294	84,426
Breakout force		kN	556	537	514	550
		lbf	124,982	120,704	115,628	123,669
Operating weight		kg	85 599	85 772	85 924	87 136
		lb	188,713	189,094	189,429	192,102
Weight distribution at SAE carry — unloaded	Front	kg	46 516	46 860	47 139	49 363
		lb	102,551	103,309	103,923	108,826
	Rear	kg	39 082	38 912	38 785	37 773
		lb	86,162	85,786	85,506	83,275
Weight distribution at SAE carry — loaded	Front	kg	75 305	75 696	75 953	78 137
		lb	166,019	166,882	167,449	172,263
	Rear	kg	26 169	25 950	25 845	24 874
		lb	57,692	57,211	56,979	54,837

*Tipping Load is calculated without tire squash.

Bucket Type	Standard Lift						
	Rock			Heavy Duty Rock		High Abrasion Rock	
	Teeth & Segments	Teeth & Segments	Teeth & Segments	Teeth & Segments	Teeth & Segments	Teeth & Segments	Teeth & Segments
Ground Engaging Tools							
Cutting Edge Type		Spade	Spade	Spade	Spade	Spade	Spade
Rated bucket capacity (\$)	m ³	10.7	11.5	12.3	10.7	11.5	10.7
	yd ³	14.0	15.0	16.0	14.0	15.0	14.0
Operating load at rated capacity	kg	21 773	21 773	21 773	21 773	21 773	21 773
	lb	48,000	48,000	48,000	48,000	48,000	48,000
Struck capacity (\$)	m ³	8.9	9.5	10.2	8.9	9.5	8.9
	yd ³	11.6	12.4	13.3	11.6	12.4	11.6
Bucket width (\$)	mm	4824	4884	4824	5068	4824	5165
	ft/in	15'10"	16'0"	15'10"	16'7"	15'10"	16'11"
Dump clearance at full lift	mm	4849	4785	4741	4849	4788	4935
SAE 45° discharge (\$)	ft/in	15'11"	15'8"	15'7"	15'11"	15'8"	16'2"
	Teeth tip	mm	4607	4548	4495	4612	4545
		ft/in	15'1"	14'11"	14'8"	15'1"	14'11"
Reach at full lift SAE	mm	2092	2149	2194	2092	2151	2036
45° discharge (\$)	ft/in	6'11"	7'0"	7'2"	6'11"	7'11"	6'10"
	Teeth tip	mm	2326	2378	2427	2322	2385
		ft/in	7'7"	7'10"	8'0"	7'7"	7'10"
Reach with boom horizontal and bucket level	mm	5114	5193	5265	5108	5200	5025
	ft/in	16'10"	17'0"	17'4"	16'10"	17'1"	16'6"
Digging depth (segment) (\$)	mm	196	201	201	196	198	175
	in	7.7	7.9	7.9	7.7	7.8	6.9
Overall length — bucket level ground (\$)	mm	15 736	15 818	15 890	15 729	15 823	15 632
	ft/in	51'7"	51'11"	51'1"	51'7"	51'11"	51'4"
Overall height with bucket at full raise (\$)	mm	9313	9313	9492	9313	9313	9392
	ft/in	30'7"	30'7"	31'1"	30'7"	30'7"	30'10"
Loader clearance radius with bucket in carry position (\$)	mm	11 097	11 121	11 131	11 096	11 122	11 085
	ft/in	36'5"	36'6"	36'6"	36'5"	36'6"	36'5"
Tipping load straight* (\$)	kg	55 216	54 526	54 184	53 745	54 784	51 692
	lb	121,730	120,209	119,455	118,487	120,778	113,961
Static tipping load full 35° turn* (\$)	kg	48 361	47 695	47 341	46 893	47 953	44 839
	lb	106,618	105,149	104,369	103,381	105,718	98,853
Static tipping load full 40° turn* (\$)	kg	46 440	45 780	45 422	44 972	46 037	42 919
	lb	102,383	100,928	100,138	99,146	101,494	94,620
Static tipping load full 43° turn* (\$)	kg	45 201	44 546	44 185	43 735	44 803	41 681
	lb	99,651	98,207	97,411	96,419	98,774	91,891
Tipping load straight** (\$)	kg	57 096	56 402	56 093	55 615	56 662	53 564
	lb	125,874	124,344	123,663	122,610	124,918	118,088
Static tipping load full 35° turn** (\$)	kg	51 328	50 653	50 338	49 847	50 913	47 796
	lb	113,158	111,671	110,976	109,893	112,244	105,372
Static tipping load full 40° turn** (\$)	kg	49 634	48 965	48 648	48 153	49 225	46 102
	lb	109,424	107,950	107,250	106,159	108,523	101,638
Static tipping load full 43° turn** (\$)	kg	48 527	47 863	47 544	47 047	48 123	44 996
	lb	106,984	105,519	104,817	103,720	106,092	99,198
Breakout force*** (\$)	kg	58 466	55 998	54 249	57 842	56 147	59 381
	lb	128,894	123,454	119,599	127,519	123,782	130,913
Operating weight*** (\$)	kg	98 610	99 012	99 391	100 786	97 469	102 956
	lb	217,398	218,284	219,119	222,195	214,882	226,979

*Tipping loads were calculated within guidelines of ISO 14397-1:2007 to include tire squash (Tire pressure at 683 kPa [99 psi]).

**Tipping load is calculated without tire squash.

***Static tipping load and operating weight shown are based on standard machine configurations with a fuel tank, coolant, lubricants, and operator.

NOTE: Specifications and ratings conform to all applicable standards recommended by the Society for Automotive Engineers. SAE Standards J732C govern loader ratings and are denoted in the text by (\$).

Bucket Type		High Lift					
		Rock			Heavy Duty Rock		High Abrasion Rock
Ground Engaging Tools		Teeth & Segments	Teeth & Segments	Teeth & Segments	Teeth & Segments	Teeth & Segments	Teeth & Segments
Cutting Edge Type		Spade	Spade	Spade	Spade	Spade	Spade
Rated bucket capacity (§)	m ³	10.7	11.5	12.3	10.7	11.5	10.7
	yd ³	14.0	15.0	16.0	14.0	15.0	14.0
Operating load at rated capacity	kg	19 051	19 051	19 051	19 051	19 051	19 051
	lb	42,000	42,000	42,000	42,000	42,000	42,000
Struck capacity (§)	m ³	8.9	9.5	10.2	8.9	9.5	8.9
	yd ³	11.6	12.4	13.3	11.6	12.4	11.6
Bucket width (§)	mm	4824	4884	4824	4884	4824	4900
	ft/in	15'10"	16'0"	15'10"	16'7"	15'10"	16'11"
Dump clearance at full lift SAE 45° discharge (§)	Teeth tip mm	5224	5166	5112	5229	5162	5316
	ft/in	17'2"	16'11"	16'9"	17'2"	16'11"	17'5"
Reach at full lift SAE 45° discharge (§)	Teeth tip mm	2193	2246	2294	2189	2252	2159
	ft/in	7'2"	7'4"	7'6"	7'2"	7'5"	7'1"
Reach with boom horizontal and bucket level	mm	5504	5583	5655	5498	5590	5415
	ft/in	18'1"	18'4"	18'7"	18'0"	18'4"	17'9"
Digging depth (segment) (§)	mm	176	181	181	176	178	155
	in	7.0	7.0	7.0	7.0	7.0	6.0
Overall length — bucket level ground (§)	mm	16 197	16 279	16 351	16 191	16 284	16 095
	ft/in	53'2"	53'5"	53'8"	53'1"	53'5"	52'10"
Overall height with bucket at full raise (§)	mm	9930	9930	9930	9930	9930	9930
	ft/in	32'7"	32'7"	32'7"	32'7"	32'7"	32'7"
Loader clearance radius with bucket in carry position (§)	mm	11 326	11 352	11 349	11 324	11 352	11 313
	ft/in	37'2"	37'3"	37'3"	37'2"	37'3"	37'1"
Tipping load straight* (§)	kg	51 408	50 761	50 436	49 938	51 017	47 875
	lb	113,335	111,909	111,192	110,094	112,473	105,546
Static tipping load full 35° turn* (§)	kg	44 798	44 172	43 833	43 332	44 427	41 268
	lb	98,763	97,382	96,635	95,531	97,945	90,980
Static tipping load full 40° turn* (§)	kg	42 946	42 325	41 981	41 481	42 580	39 417
	lb	94,680	93,311	92,552	91,450	93,873	86,900
Static tipping load full 43° turn* (§)	kg	41 753	41 135	40 789	40 288	41 390	38 224
	lb	92,049	90,687	89,924	88,820	91,249	84,269
Tipping load straight** (§)	kg	53 044	52 396	52 099	51 567	52 653	49 505
	lb	116,942	115,513	114,858	113,686	116,080	109,140
Static tipping load full 35° turn** (§)	kg	47 472	46 840	46 535	45 994	47 097	43 932
	lb	104,658	103,264	102,592	101,399	103,831	96,853
Static tipping load full 40° turn** (§)	kg	45 835	45 209	44 901	44 358	45 466	42 296
	lb	101,049	99,669	98,990	97,793	100,235	93,247
Static tipping load full 43° turn** (§)	kg	44 766	44 143	43 834	43 289	44 400	41 227
	lb	98,692	97,319	96,637	95,436	97,885	90,890
Breakout force*** (§)	kg	57 948	55 495	53 760	57 324	55 656	58 856
	lb	127,753	122,345	118,520	126,378	122,700	129,755
Operating weight*** (§)	kg	99 788	100 182	100 561	101 956	99 963	104 126
	lb	219,995	220,863	221,699	224,774	220,380	229,558

*Tipping loads were calculated within guidelines of ISO 14397-1:2007 to include tire squash (Tire pressure at 683 kPa [99 psi]).

**Tipping load is calculated without tire squash.

***Static tipping load and operating weight shown are based on standard machine configurations with a fuel tank, coolant, lubricants, and operator.

NOTE: Specifications and ratings conform to all applicable standards recommended by the Society for Automotive Engineers. SAE Standards J732C govern loader ratings and are denoted in the text by (§).

Bucket Type		993K STD Tires: 50/65-51 Part No. 311-1938 SLR: 1461 mm							
		Rock						Coal	
Ground Engaging Tools		Teeth & Segments	Teeth & Segments	Teeth & Segments	Teeth & Segments	Teeth & Segments	Teeth & Segments	Teeth & Segments	
Cutting Edge Type		Spade	Spade	Spade	Spade	Spade	Spade	Straight	
Bucket Part Number — group level		303-3270	303-3310	303-3260	303-3330	303-3280	303-3290	310-8990	
Bucket load at rated capacity	kg	27 216	27 216	27 216	27 216	27 216	27 216	27 216	
	lb	60,000	60,000	60,000	60,000	60,000	60,000	60,000	
Rated capacity (\$)	m ³	10.0	10.0	10.0	10.0	11.0	12.0	20.0	
	yd ³	13.1	13.1	13.1	13.1	14.4	15.7	26.2	
Heaped capacity (\$)	m ³	13.0	13.0	12.0	12.0	14.0	14.0	24.0	
	yd ³	17.0	17.0	15.7	15.7	18.3	18.3	31.4	
Bucket width (\$)	mm	5080	5160	5080	5160	5080	5080	6300	
	ft	16.7	16.9	16.7	16.9	16.7	16.7	20.7	
Dump clearance at full lift and 45° discharge* (\$)	mm	4768	4835	4858	4883	4669	4669	4614	
	ft	15.6	15.9	15.9	16.0	15.3	15.3	15.1	
Reach at lift and 45° discharge*** (\$)	mm	2503	2507	2413	2459	2602	2602	2605	
	ft	8.2	8.2	7.9	8.1	8.5	8.5	8.5	
Reach with lift arms horizontal and bucket level* (\$)	mm	4922	4878	4794	4810	5062	5062	5103	
	ft	16.1	16.0	15.7	15.8	16.6	16.6	16.7	
Digging depth — segment (\$)	mm	132	117	132	117	132	132	154	
	in	5.2	4.6	5.2	4.6	5.2	5.2	6.1	
Overall length — bucket level ground	mm	15 124	15 068	14 996	15 000	15 264	15 264	15 323	
	ft	49.6	49.4	49.2	49.2	50.1	50.1	50.3	
Overall height with bucket at full raise	mm	9903	9876	9794	9794	9903	10 032	10 030	
	ft	32.5	32.4	32.1	32.1	32.5	32.9	32.9	
Loader clearance turning radius — SAE carry (\$)	mm	11 012	11 016	11 013	10 998	11 049	11 049	11 746	
	ft	36.1	36.1	36.1	36.1	36.2	36.2	38.5	
Full dump angle	degrees	-50	-50	-50	-50	-50	-50	-50	
Static tipping load straight # ** (\$)	kg	83 096	81 703	83 263	82 300	81 931	82 147	78 089	
	lb	183,194	180,124	183,563	181,440	180,626	181,102	172,157	
Static tipping load straight** (\$)	kg	79 105	77 736	79 312	78 354	77 962	78 114	73 991	
	lb	174,396	171,378	174,853	172,741	171,877	172,212	163,122	
Static tipping load — full turn (articulated 40 degrees) # ** (\$)	kg	71 976	70 608	72 159	71 193	70 886	71 056	67 100	
	lb	158,680	155,664	159,084	156,953	156,276	156,651	147,930	
Static tipping load — full turn (articulated 40 degrees)** (\$)	kg	64 192	62 859	64 431	63 471	63 141	63 220	59 190	
	lb	141,519	138,580	142,046	139,929	139,202	139,376	130,491	
Static tipping load — full turn (articulated 43 degrees) # ** (\$)	kg	70 327	68 963	70 513	69 546	69 248	69 411	65 470	
	lb	155,045	152,037	155,454	153,322	152,665	153,025	144,337	
Static tipping load — full turn (articulated 43 degrees)** (\$)	kg	61 906	62 065	63 762	63 342	59 853	59 704	56 337	
	lb	136,479	136,830	140,571	139,645	131,953	131,625	124,202	
Breakout force (\$)	kN	718	734	762	761	674	673	638	
	lbf	161,390	165,010	171,372	171,035	151,499	151,252	143,361	
Operating weight** (\$)	kg	132 251	133 234	131 988	132 788	132 702	132 877	135 859	
	lb	291,564	293,731	290,984	292,748	292,558	292,944	299,518	
Weight distribution at SAE carry — unloaded**	Front	kg	76 930	78 615	76 482	77 858	77 770	78 022	83 099
		lb	169,601	173,315	168,614	171,647	171,453	172,008	183,203
	Rear	kg	55 322	54 620	55 506	54 930	54 933	54 856	52 760
		lb	121,963	120,416	122,370	121,101	121,105	120,936	116,316
Weight distribution at SAE carry — loaded**	Front	kg	120 265	121 981	119 797	121 151	121 280	121 508	127 036
		lb	265,139	268,922	264,106	267,091	267,377	267,880	280,065
	Rear	kg	39 202	38 469	39 408	38 854	38 638	38 585	36 040
		lb	86,426	84,810	86,879	85,658	85,182	85,065	79,454

*Dimensions are measured to the tip of the bucket teeth to provide accurate clearance data. SAE Standards specifies the cutting edge.

**Static tipping load and operating weight shown are based on standard machine configuration with 50/65-51 tires, full fuel tank, coolant and lubricants.

***Measured 102 mm (4") behind tip of cutting edge with bucket hinge pin as pivot point in accordance with SAE J732 JUN92.

#Tipping load is calculated without tire squash.

NOTE: Specifications and ratings conform to all applicable standards recommended by the Society of Automotive Engineers (SAE). SAE Standards J732 JUN92 and J742 FEB85 govern loader ratings denoted in text by (\$).

Wheel Loaders Integrated Toolcarriers

Performance Data ● 993K

Bucket Type		993K HL Tires: 50/65-51 Part No. 311-1938 SLR: 1461 mm							
		Rock						Coal	
Ground Engaging Tools		Teeth & Segments	Teeth & Segments	Teeth & Segments	Teeth & Segments	Teeth & Segments	Teeth & Segments	Teeth & Segments	
Cutting Edge Type		Spade	Spade	Spade	Spade	Spade	Spade	Straight	
Bucket Part Number — group level		303-3270	303-3310	303-3260	303-3330	303-3280	303-3290	310-8990	
Bucket load at rated capacity	kg	24 948	24 948	24 948	24 948	24 948	24 948	24 948	
	lb	55,000	55,000	55,000	55,000	55,000	55,000	55,000	
Rated capacity (\$)	m ³	12.8	12.8	12.0	12.0	13.8	14.5	23.7	
	yd ³	16.7	16.7	15.7	15.7	18.0	19.0	31.0	
Struck capacity (\$)	m ³	10.0	10.0	10.0	10.0	11.0	12.0	20.0	
	yd ³	13.1	13.1	13.1	13.1	14.4	15.7	26.2	
Heaped capacity (\$)	m ³	13.0	13.0	12.0	12.0	14.0	14.0	24.0	
	yd ³	17.0	17.0	15.7	15.7	18.3	18.3	31.4	
Bucket width (\$)	mm	5080	5160	5080	5160	5080	5080	6300	
	ft	16.7	16.9	16.7	16.9	16.7	16.7	20.7	
Dump clearance at full lift and 45° discharge* (\$)	mm	5413	5480	5503	5528	5314	5314	5259	
	ft	17.8	18.0	18.1	18.1	17.4	17.4	17.3	
Reach at lift and 45° discharge*** (\$)	mm	2612	2616	2522	2568	2711	2711	2714	
	ft	8.6	8.6	8.3	8.4	8.9	8.9	8.9	
Reach with lift arms horizontal and bucket level* (\$)	mm	5438	5394	5310	5326	5578	5578	5619	
	ft	17.8	17.7	17.4	17.5	18.3	18.3	18.4	
Digging depth (segment) (\$)	mm	199	184	199	184	199	199	221	
	in	7.8	7.2	7.8	7.2	7.8	7.8	8.7	
Overall length — bucket level ground	mm	5953.9	5898.8	5825.9	5830.8	6093.9	6093.9	6150.1	
	ft	19.5	19.4	19.1	19.1	20.0	20.0	20.2	
Overall height with bucket at full raise	mm	10 547	10 521	10 439	10 439	10 547	10 677	10 675	
	ft	34.6	34.5	34.2	34.2	34.6	35.0	35.0	
Loader clearance turning radius (SAE carry) (\$)	mm	11 308	11 311	11 309	11 292	11 348	11 348	12 043	
	ft	37.1	37.1	37.1	37.0	37.2	37.2	39.5	
Full dump angle	degrees	-50	-50	-50	-50	-50	-50	-50	
Static tipping load straight # ** (\$)	kg	69 659	68 341	69 856	68 908	68 656	68 775	64 946	
	lb	153,571	150,665	154,006	151,916	151,360	151,624	143,182	
Static tipping load straight** (\$)	kg	66 576	65 274	66 804	65 860	65 583	65 656	61 751	
	lb	146,775	143,904	147,277	145,196	144,586	144,747	136,137	
Static tipping load — full turn (articulated 40 degrees) # ** (\$)	kg	59 871	58 572	60 081	59 130	58 927	59 011	55 261	
	lb	131,994	129,130	132,455	130,359	129,911	130,096	121,830	
Static tipping load — full turn (articulated 40 degrees)** (\$)	kg	53 578	52 304	53 828	53 252	52 657	52 674	48 854	
	lb	118,119	115,310	118,670	117,400	116,089	116,126	107,705	
Static tipping load — full turn (articulated 43 degrees) # ** (\$)	kg	58 420	57 124	58 631	57 680	57 484	57 563	53 825	
	lb	128,794	125,936	129,259	127,163	126,730	126,904	118,664	
Static tipping load — full turn (articulated 43 degrees)** (\$)	kg	52 300	52 185	53 770	52 882	50 628	50 476	47 250	
	lb	115,302	115,048	118,542	116,585	111,616	111,280	104,168	
Breakout force (\$)	kN	717	733	761	760	673	672	637	
	lbf	161,143	164,740	171,125	170,765	151,274	151,004	143,158	
Operating weight** (\$)	kg	133 217	134 200	132 954	133 754	133 668	133 843	136 825	
	lb	293,694	295,861	293,114	294,878	294,688	295,074	301,648	
Weight distribution at SAE carry — unloaded**	Front	kg	81 114	82 919	80 637	82 111	82 005	82 276	87 684
		lb	178,825	182,804	177,774	181,024	180,790	181,388	193,311
	Rear	kg	52 104	51 282	52 317	51 643	51 663	51 567	49 141
		lb	114,869	113,057	115,340	113,854	113,898	113,686	108,337
Weight distribution at SAE carry — loaded**	Front	kg	123 719	125 558	123 225	124 686	124 768	125 014	130 818
		lb	272,753	276,808	271,665	274,884	275,066	275,609	288,404
	Rear	kg	34 446	33 590	34 677	34 017	33 848	33 777	30 956
		lb	75,941	74,054	76,450	74,994	74,623	74,465	68,245

*Dimensions are measured to the tip of the bucket teeth to provide accurate clearance data. SAE Standards specifies the cutting edge.

**Static tipping load and operating weight shown are based on standard machine configuration with 50/65-51 tires, full fuel tank, coolant and lubricants.

***Measured 102 mm (4") behind tip of cutting edge with bucket hinge pin as pivot point in accordance with SAE J732 JUN92.

#Tipping load is calculated without tire squash.

NOTE: Specifications and ratings conform to all applicable standards recommended by the Society of Automotive Engineers (SAE). SAE Standards J732 JUN92 and J742 FEB85 govern loader ratings denoted in text by (\$).

993K Performance Conversion Table Based on Tire Selection

		50/65-51 (311-1938)	50/65R51 (311-2443)	50/65-51 (322-9665)	50/65R51 (311-2445)
Dump clearance at full lift and 45° discharge	mm	0	-51	0	-20
	ft	0	0	0	0
Reach at full lift and 45° discharge	mm	0	0	0	-2
	ft	0	0	0	0
Reach with lift arms horizontal and bucket level	mm	0	0	0	-2
	ft	0	0	0	0
Digging depth	mm	0	51	0	20
	ft	0	0	0	0
Overall length	mm	0	41	0	16
	ft	0	0	0	0
Overall height with bucket at full raise	mm	0	-51	0	-20
	ft	0	0	0	0
Total width (width over tires)	mm	0	18	0	13
	ft	0	0	0	0
Static tipping load straight (no tire squash)	kg	0	0	0	-583
	lb	0	0	0	-1285
Static tipping load straight (with tire squash)	kg	0	-850	0	-2319
	lb	0	-1874	0	-5113
Static tipping load — full turn (articulated 40°) (no tire squash)	kg	0	0	0	-515
	lb	0	0	0	-1135
Static tipping load — full turn (articulated 40°) (with tire squash)	kg	0	-1000	0	3398
	lb	0	-2205	0	-7491
Static tipping load — full turn (articulated 43°) (no tire squash)	kg	0	0	0	-505
	lb	0	0	0	-1113
Static tipping load — full turn (articulated 43°) (with tire squash)	kg	0	-730	0	-1774
	lb	0	-1609	0	-3911
Operating weight	kg	0	0	0	-760
	lb	0	0	0	-1676

NOTE: 50/65-51 used as baseline tire; 303-3280 bucket.

		994K Standard Lift			
Bucket Type		Rock			
Ground Engaging Tools		Teeth & Segments	Teeth & Segments	Teeth & Segments	Teeth & Segments
Cutting Edge Type		Spade	Spade	Spade	Spade
Bucket Part Number – group level		389-4420	389-4430	389-4440	389-4450
Bucket load at rated capacity	kg	40 823	40 823	40 823	40 823
	lb	90,000	90,000	90,000	90,000
Rated capacity	m³	19.1	21.4	22.9	24.5
	yd³	25.0	28.0	30.0	32.0
Struck capacity – ISO	m³	15.0	18.0	19.0	20.0
	yd³	19.6	23.5	24.9	26.2
Heaped capacity – ISO	m³	19.0	21.0	23.0	24.0
	yd³	24.9	27.5	30.0	31.4
Bucket width – overall	mm	6240	6240	6240	6240
	ft	20.5	20.5	20.5	20.5
Clearance at 45° dump (tooth tip)	mm	6347	6238	6167	6100
	ft	20.8	20.5	20.2	20.0
Reach at 45° dump (tooth tip)	mm	2641	2750	2821	2888
	ft	8.7	9.0	9.3	9.5
Bucket pin at maximum lift	mm	8790	8790	8790	8790
	ft	28.8	28.8	28.8	28.8
Horizontal arm and level bucket reach	mm	5583	5737	5837	5932
	ft	18.3	18.8	19.1	19.5
Digging depth (segment)	mm	232	232	232	232
	in	0.8	0.8	0.8	0.8
Overall length – bucket level ground	mm	17 606	17 760	17 860	17 955
	ft	57.8	58.3	58.6	58.9
Front axle to bucket tip ground	mm	6249	6403	6503	6598
	ft	20.5	21.0	21.3	21.6
Overall height	mm	11 541	11 688	11 771	11 874
	ft	37.9	38.3	38.6	39.0
Turning radius – corner SAE carry	mm	13 727	13 771	13 800	13 828
	ft	45.0	45.2	45.3	45.4
Reach at 45° dump and 2.13 m (7 ft) height (with teeth)	mm	4349	4454	4522	4585
	ft	14.3	14.6	14.8	15.0
Rack back angle at SAE carry	degrees	47.7	47.7	47.7	47.7
Full dump at maximum lift	degrees	-50.0	-50.0	-50.0	-50.0

		994K Standard Lift			
Bucket Type		Rock			
Ground Engaging Tools		Teeth & Segments	Teeth & Segments	Teeth & Segments	Teeth & Segments
Cutting Edge Type		Spade	Spade	Spade	Spade
Bucket Part Number – group level		389-4420	389-4430	389-4440	389-4450
Bucket load at rated capacity	kg	40 823	40 823	40 823	40 823
	lb	90,000	90,000	90,000	90,000
Rated capacity	m ³	19.1	21.4	22.9	24.5
	yd ³	25.0	28.0	30.0	32.0
Struck capacity – ISO	m ³	15.0	18.0	19.0	20.0
	yd ³	19.6	23.5	24.9	26.2
Heaped capacity – ISO	m ³	19.0	21.0	23.0	24.0
	yd ³	24.9	27.5	30.0	31.4
Tipping load at operating weight – straight	kg	159 823	158 190	157 062	156 085
	lb	352,348	348,749	346,263	344,107
Tipping load at operating weight – straight*	kg	150 697	149 006	147 840	146 825
	lb	332,230	328,502	325,931	323,693
Tipping load at operating weight – articulated 40°	kg	137 845	136 286	135 207	134 275
	lb	303,896	300,459	298,081	296,025
Tipping load at operating weight – articulated 40°*	kg	123 391	121 745	120 610	119 624
	lb	272,030	268,401	265,899	263,725
Tipping load at operating weight – bucket level ground	kg	135 113	130 634	127 808	125 353
	lb	297,872	287,997	281,768	276,356
Tipping load at operating weight – bucket level ground*	kg	126 010	121 984	119 430	117 209
	lb	277,804	268,928	263,298	258,401
Breakout force – SAE rated	kN	1401.1	1307.7	1252.7	1206.2
	lbf	314,980	293,992	281,617	271,160
Operating weight	kg	238 466	239 371	240 018	240 554
	lb	525,727	527,723	529,149	530,329
Weight distribution at SAE carry – front	kg	124 673	126 336	127 518	128 511
	lb	274,858	278,522	281,129	283,319
Weight distribution at SAE carry – rear	kg	113 792	113 036	112 500	112 042
	lb	250,869	249,200	248,020	247,010
Loaded machine weight	kg	279 289	280 194	280 841	281 377
	lb	615,726	617,722	619,148	620,329
Weight distribution at SAE carry – front	kg	192 099	193 989	195 324	196 461
	lb	423,505	427,672	430,615	433,121
Weight distribution at SAE carry – rear	kg	87 190	86 205	85 518	84 916
	lb	192,220	190,050	188,534	187,208

*With tire squash.

		994K High Lift			
Bucket Type		Rock			
Ground Engaging Tools		Teeth & Segments	Teeth & Segments	Teeth & Segments	Teeth & Segments
Cutting Edge Type		Spade	Spade	Spade	Spade
Bucket Part Number – group level		389-4420	389-4430	389-4440	389-4450
Bucket load at rated capacity	kg	38 102	38 102	38 102	38 102
	lb	84,000	84,000	84,000	84,000
Rated capacity	m³	19.1	21.4	22.9	24.5
	yd³	25.0	28.0	30.0	32.0
Struck capacity – ISO	m³	15.0	18.0	19.0	20.0
	yd³	19.6	23.5	24.9	26.2
Heaped capacity – ISO	m³	19.0	21.0	23.0	24.0
	yd³	24.9	27.5	30.0	31.4
Bucket width – overall	mm	6240	6240	6240	6240
	ft	20.5	20.5	20.5	20.5
Clearance at 45° dump (tooth tip)	mm	7204	7095	7024	6957
	ft	23.6	23.3	23.0	22.8
Reach at 45° dump (tooth tip)	mm	2579	2688	2758	2826
	ft	8.5	8.8	9.0	9.3
Bucket pin at maximum lift	mm	9647	9647	9647	9647
	ft	31.6	31.6	31.6	31.6
Horizontal arm and level bucket reach	mm	6149	6303	6403	6498
	ft	20.2	20.7	21.0	21.3
Digging depth (segment)	mm	239	239	239	239
	in	0.8	0.8	0.8	0.8
Overall length – bucket level ground	mm	18 300	18 454	18 554	18 649
	ft	60.0	60.5	60.9	61.2
Front axle to bucket tip ground	mm	6943	7097	7197	7292
	ft	22.8	23.3	23.6	23.9
Overall height	mm	12 398	12 545	12 628	12 731
	ft	40.7	41.2	41.4	41.8
Turning radius – corner SAE carry	mm	13 976	14 017	14 045	14 071
	ft	45.9	46.0	46.1	46.2
Reach at 45° dump and 2.13 m (7 ft) height (with teeth)	mm	4916	5021	5088	5152
	ft	16.1	16.5	16.7	16.9
Rack back angle at SAE carry	degrees	53.5	53.5	53.5	53.5
Full dump at maximum lift	degrees	-50.0	-50.0	-50.0	-50.0

		994K High Lift			
Bucket Type		Rock			
Ground Engaging Tools		Teeth & Segments	Teeth & Segments	Teeth & Segments	Teeth & Segments
Cutting Edge Type		Spade	Spade	Spade	Spade
Bucket Part Number – group level		389-4420	389-4430	389-4440	389-4450
Bucket load at rated capacity	kg	40 823	40 823	40 823	40 823
	lb	90,000	90,000	90,000	90,000
Rated capacity	m ³	19.1	21.4	22.9	24.5
	yd ³	25.0	28.0	30.0	32.0
Struck capacity – ISO	m ³	15.0	18.0	19.0	20.0
	yd ³	19.6	23.5	24.9	26.2
Heaped capacity – ISO	m ³	19.0	21.0	23.0	24.0
	yd ³	24.9	27.5	30.0	31.4
Tipping load at operating weight – straight	kg	140 091	138 667	137 676	136 827
	lb	308,847	305,708	303,524	301,651
Tipping load at operating weight – straight*	kg	132 782	131 300	130 272	129 385
	lb	292,734	289,467	287,200	285,245
Tipping load at operating weight – articulated 40°	kg	120 292	118 917	117 960	117 141
	lb	265,198	262,168	260,057	258,251
Tipping load at operating weight – articulated 40°*	kg	108 277	106 814	105 800	104 925
	lb	238,710	235,484	233,249	231,320
Tipping load at operating weight – bucket level ground	kg	117 056	113 375	111 031	108 994
	lb	258,063	249,948	244,782	240,291
Tipping load at operating weight – bucket level ground*	kg	110 225	106 841	104 676	102 794
	lb	243,004	235,544	230,771	226,622
Breakout force – SAE rated	kN	1335.0	1245.6	1192.9	1148.3
	lbf	300,129	280,028	268,171	258,148
Operating weight	kg	239 693	240 598	241 245	241 781
	lb	528,432	530,428	531,854	533,034
Weight distribution at SAE carry – front	kg	129 194	130 922	132 151	133 180
	lb	284,823	288,633	291,343	293,611
Weight distribution at SAE carry – rear	kg	110 499	109 677	109 094	108 601
	lb	243,609	241,795	240,511	239,423
Loaded machine weight	kg	277 795	278 700	279 347	279 883
	lb	612,432	614,428	615,855	617,035
Weight distribution at SAE carry – front	kg	195 479	197 370	198 709	199 840
	lb	430,958	435,126	438,077	440,571
Weight distribution at SAE carry – rear	kg	82 315	81 330	80 639	80 043
	lb	181,474	179,302	177,777	176,464

*With tire squash.

Wheel Loaders Integrated Toolcarriers

Machine Dimensions ● 903C

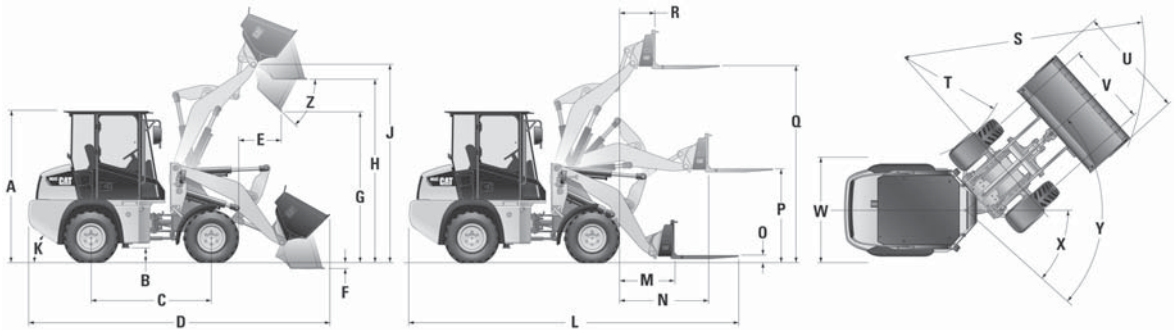

Dimensions shown are based on the machine equipped with quick coupler, general purpose bucket or 1067 mm (42 in) forks and 33 × 15.5-16.5, 12PR tires.

All dimensions are approximate.

MODEL	903C	
A Cab height	2510 mm	8'3"
B Ground clearance	395 mm	1'4"
C Wheelbase	1800 mm	5'11"
* D Overall length with bucket	4835 mm	15'10"
* E Reach at maximum dump height	885 mm	2'11"
F Dig depth	200 mm	8"
* G Maximum dump height	2430 mm	8'0"
H Load over height	2940 mm	9'8"
J Hinge pin at maximum height	3225 mm	10'7"
K Departure angle		30°
L Overall length with forks	5306 mm	17'5"
M Reach at level ground	1131 mm	3'9"
N Maximum reach	1635 mm	5'4"
O Fork depth above ground	40 mm	2"
P Fork height at maximum reach	1418 mm	4'8"
Q Maximum fork height	3143 mm	10'4"
R Fork reach at maximum height	758 mm	2'6"
* S Turning radius over bucket	4020 mm	13'2"
** T Turning radius inside tire	1655 mm	5'5"
* U Width over bucket	1770 mm	5'10"
V Tire gauge	1314 mm	4'4"
** W Machine width		
12-16.5 10PR tires	1638 mm	5'4"
Flotation 33-15.5 × 16.5 tires	1708 mm	5'7"
Flexport™ 33 × 6 × 11 tires	1593 mm	5'3"
X Articulation angle		40°
Y Steering angle – left/right		80°
Z Dump angle at maximum height		40°

*Vary with bucket size.

**Vary with tire size.

Machine Dimensions
 ● 906K/M, 907K/M, 908K/M
 ● Horizontal Pin Coupler

Wheel Loaders
 Integrated Toolcarriers

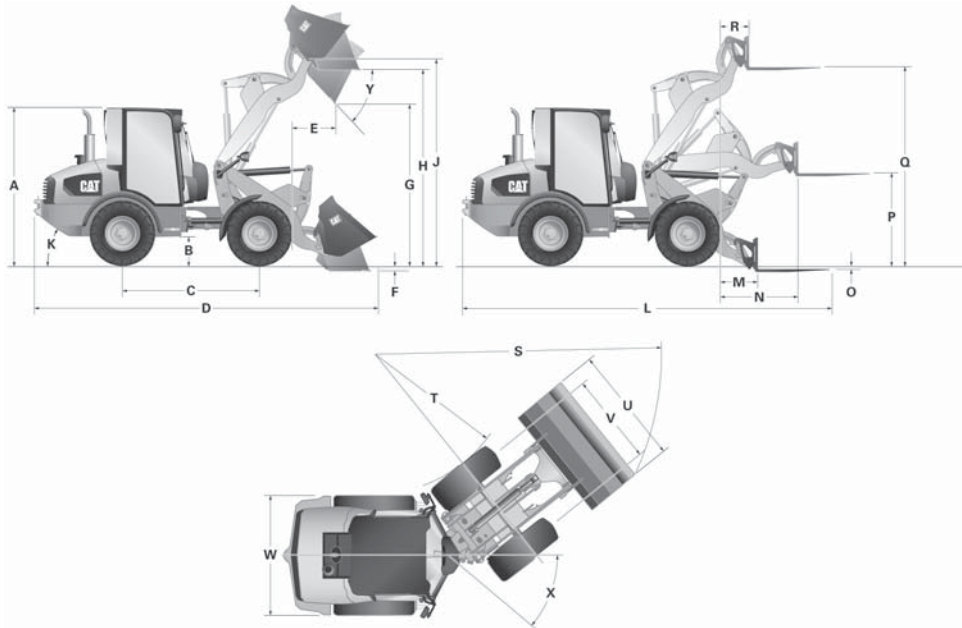

Dimensions shown are based on the machine equipped with general purpose bucket and standard 405/70 SPT9 tires.

All dimensions are approximate.

MODEL	906K/M		907K/M		908K/M	
A Cab height	2465 mm	8'1"	2585 mm	8'5"	2650 mm	8'8"
B Ground clearance	300 mm	12"	300 mm	12"	340 mm	1'1"
C Wheelbase	2170 mm	7'1"	2170 mm	7'1"	2170 mm	7'1"
D Overall length with bucket	5649 mm	17'11"	5649 mm	17'11"	5630 mm	18'5"
E Reach at maximum dump height	725 mm	2'4"	725 mm	2'4"	770 mm	2'6"
F Dig depth	95 mm	3.7"	95 mm	3.7"	101 mm	3.9"
G Maximum dump height	2478 mm	8'1"	2478 mm	8'1"	2620 mm	8'7"
H Load over height	3027 mm	9'11"	3027 mm	9'11"	3215 mm	10'7"
J Hinge pin at maximum height	3227 mm	10'7"	3227 mm	10'7"	3410 mm	11'2"
K Departure angle (degrees)	33°		33°		33°	
L Overall length with forks	5915 mm	19'4"	5915 mm	19'4"	6015 mm	19'8"
M Reach at ground level	720 mm	2'4"	720 mm	2'4"	790 mm	2'7"
N Maximum reach	1215 mm	3'11"	1215 mm	3'11"	1310 mm	4'3"
O Fork depth below ground (above ground)	25 mm	1"	25 mm	1"	70 mm	2.75"
P Fork height at maximum reach	1425 mm	4'8"	1425 mm	4'8"	1450 mm	4'9"
Q Maximum fork height	3090 mm	10'1"	3090 mm	10'1"	3225 mm	10'6"
R Fork reach at maximum height	445 mm	1'5"	445 mm	1'5"	460 mm	1'6"
S Turning radius over bucket	4400 mm	14'5"	4475 mm	14'8"	4530 mm	14'10"
T Turning radius inside tire	2240 mm	7'4"	2240 mm	7'4"	2080 mm	6'10"
U Width over bucket	1880 mm	6'2"	2035 mm	6'8"	2080 mm	6'10"
V Tire gauge	1420 mm	4'7"	1420 mm	4'7"	1570 mm	5'2"
W Machine width	1840 mm	6'0"	1840 mm	6'0"	1985 mm	6'6"
X Articulation angle (degrees)	39°		39°		39°	
Y Dump angle at maximum height (degrees)	45°		45°		45°	

Wheel Loaders Integrated Toolcarriers

Machine Dimensions

- 906K/M, 907K/M, 908K/M
- SSL Coupler

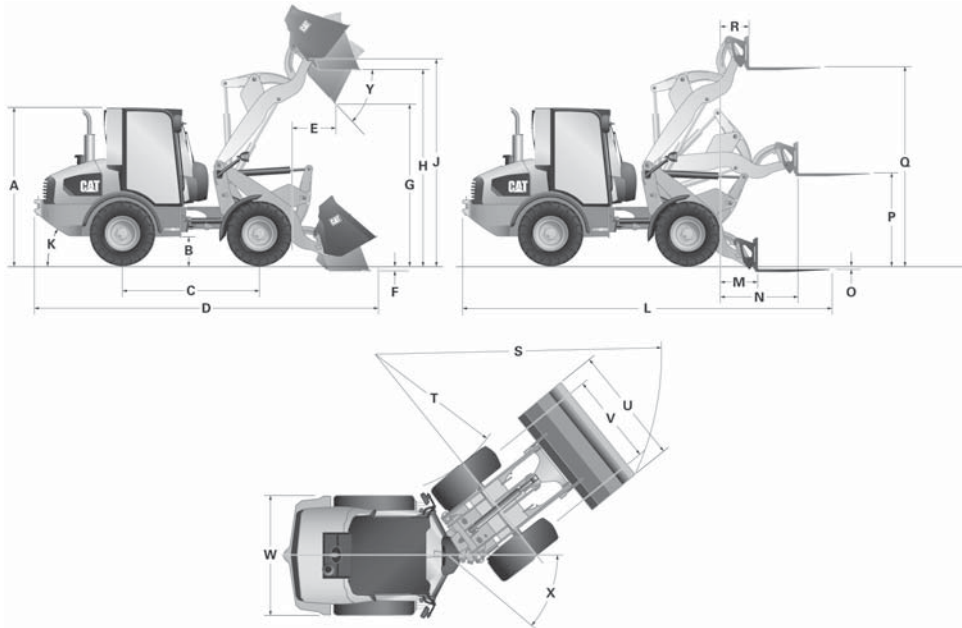

Dimensions shown are based on the machine equipped with general purpose bucket and standard 405/70 SPT9 tires.

All dimensions are approximate.

MODEL	906K/M		907K/M		908K/M	
A Cab height	2465 mm	8'1"	2585 mm	8'5"	2650 mm	8'8"
B Ground clearance	300 mm	11"	300 mm	11"	340 mm	1'1"
C Wheelbase	2170 mm	7'1"	2170 mm	7'1"	2170 mm	7'1"
D Overall length with bucket	5585 mm	18'3"	5585 mm	18'3"	5760 mm	18'10"
E Reach at maximum dump height	810 mm	2'7"	810 mm	2'7"	855 mm	2'9"
F Dig depth	90 mm	3.5"	90 mm	3.5"	95 mm	3.75"
G Maximum dump height	2395 mm	7'10"	2395 mm	7'10"	2540 mm	8'4"
H Load over height	3025 mm	9'11"	3025 mm	9'11"	3215 mm	10'7"
J Hinge pin at maximum height	3230 mm	10'7"	3230 mm	10'7"	3410 mm	11'2"
K Departure angle (degrees)	33°		33°		33°	
L Overall length with forks	5945 mm	19'6"	5945 mm	19'6"	6150 mm	20'2"
M Reach at ground level	750 mm	2'5"	750 mm	2'5"	925 mm	3'0"
N Maximum reach	1265 mm	4'1"	1265 mm	4'1"	1445 mm	4'8"
O Fork depth below ground (above ground)	(45 mm)	(1.75")	(45 mm)	(1.75")	(30 mm)	(1.15")
P Fork height at maximum reach	1490 mm	4'10"	1490 mm	4'10"	1525 mm	5'0"
Q Maximum fork height	3160 mm	10'4"	3160 mm	10'4"	3300 mm	10'9"
R Fork reach at maximum height	505 mm	1'7"	505 mm	1'7"	595 mm	1'11"
S Turning radius over bucket	4445 mm	14'7"	4515 mm	14'9"	4560 mm	15'0"
T Turning radius inside tire	2240 mm	7'4"	2240 mm	7'4"	2080 mm	6'10"
U Width over bucket	1880 mm	6'2"	2035 mm	6'8"	2060 mm	6'9"
V Tire gauge	1420 mm	4'7"	1420 mm	4'7"	1570 mm	5'2"
W Machine width	1840 mm	6'0"	1840 mm	6'0"	1985 mm	6'6"
X Articulation angle (degrees)	39°		39°		39°	
Y Dump angle at maximum height (degrees)	45°		45°		45°	

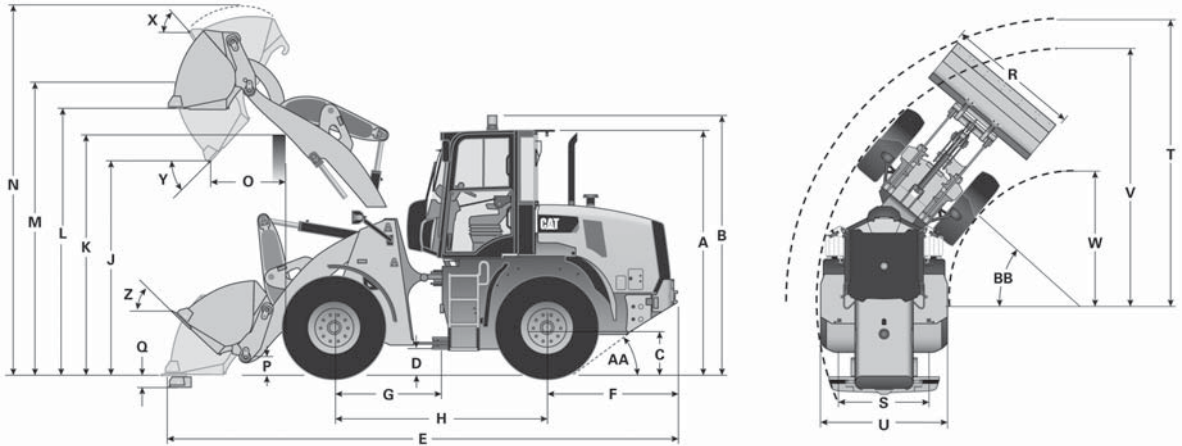

Dimensions listed are for a machine configured with general purpose pin on buckets, bolt-on cutting edges, full fuel tank, 80 kg (176 lb) operator, and standard tires.

All dimensions are approximate. Dimensions vary with bucket, couplers, and tire choice.

MODEL	910K Standard Lift and Pin On Bucket		910K High Lift and Pin On Bucket	
	** A Height: ground to cab	3020 mm	9'10"	3020 mm
** B Height: ground to beacon	3210 mm	10'6"	3210 mm	10'6"
** C Height: ground axle center	600 mm	1'11"	600 mm	1'11"
** D Height: ground clearance	348 mm	1'1"	348 mm	1'1"
* E Length: overall	6226 mm	20'5"	6758 mm	22'2"
F Length: rear axle to bumper	1590 mm	5'2"	1590 mm	5'2"
G Length: hitch to front axle	1300 mm	4'3"	1300 mm	4'3"
H Length: wheel base	2600 mm	8'6"	2600 mm	8'6"
* J Clearance: bucket at 45°	2846 mm	9'4"	3202 mm	10'6"
** K Clearance: load over height	3284 mm	10'9"	3397 mm	11'1"
** L Clearance: level bucket	3419 mm	11'2"	3775 mm	12'4"
** M Height: bucket pin	3673 mm	12'0"	4030 mm	13'2"
** N Height: overall	4534 mm	14'10"	4891 mm	16'0"
* O Reach: bucket at 45°	759 mm	2'5"	978 mm	3'2"
P Carry height: bucket pin	319 mm	1'0"	480 mm	1'6"
** Q Dig depth	116 mm	4.5"	294 mm	11.5"
R Width: bucket	2401 mm	7'10"	2401 mm	7'10"
S Width: tread center	1800 mm	5'10"	1800 mm	5'10"
T Turning radius: over bucket	5180 mm	16'11"	5419 mm	17'9"
U Width: over tires	2259 mm	7'4"	2259 mm	7'4"
V Turning radius: outside of tires	4783 mm	15'8"	4783 mm	15'8"
W Turning radius: inside of tires	2442 mm	8'0"	2442 mm	8'0"
X Rack angle at full lift		57°		59°
Y Dump angle at full lift		47°		43°
Z Rack angle at carry		42°		50°
AA Departure angle		33°		33°
BB Articulation angle		40°		40°
Operating weight	7130 kg	15,718 lb	7639 kg	16,837 lb

*Varies with bucket.

**Varies with tires.

Wheel Loaders Integrated Toolcarriers

Machine Dimensions ● 910K

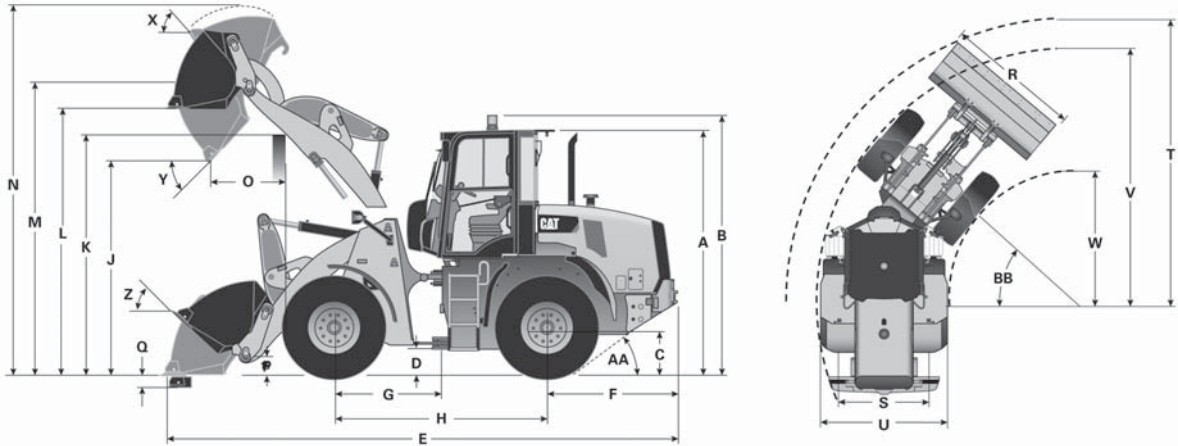

Dimensions listed are for a machine configured with general purpose pin on buckets, bolt-on cutting edges, full fuel tank, 80 kg (176 lb) operator, and standard tires.

All dimensions are approximate. Dimensions vary with bucket, couplers, and tire choice.

MODEL	910K		910K	
	Standard Lift and IT Bucket		High Lift and IT Bucket	
**A Height: ground to cab	3020 mm	9'10"	3020 mm	9'10"
**B Height: ground to beacon	3210 mm	10'6"	3210 mm	10'6"
**C Height: ground axle center	600 mm	1'11"	600 mm	1'11"
**D Height: ground clearance	348 mm	1'1"	348 mm	1'1"
*E Length: overall	6293 mm	20'7"	6825 mm	22'4"
F Length: rear axle to bumper	1590 mm	5'2"	1590 mm	5'2"
G Length: hitch to front axle	1300 mm	4'3"	1300 mm	4'3"
H Length: wheel base	2600 mm	8'6"	2600 mm	8'6"
*J Clearance: bucket at 45°	2809 mm	9'2"	3166 mm	10'4"
**K Clearance: load over height	3284 mm	10'9"	3397 mm	11'1"
**L Clearance: level bucket	3418 mm	11'2"	3774 mm	12'4"
**M Height: bucket pin	3673 mm	12'0"	4030 mm	13'2"
**N Height: overall	4563 mm	14'11"	4920 mm	16'1"
*O Reach: bucket at 45°	820 mm	2'8"	1039 mm	3'4"
P Carry height: bucket pin	319 mm	1'0"	480 mm	1'6"
**Q Dig depth	117 mm	4.5"	295 mm	11.6"
R Width: bucket	2401 mm	7'10"	2401 mm	7'10"
S Width: tread center	1800 mm	5'10"	1800 mm	5'10"
T Turning radius: over bucket	5200 mm	17'0"	5440 mm	17'10"
U Width: over tires	2259 mm	7'4"	2259 mm	7'4"
V Turning radius: outside of tires	4783 mm	15'8"	4783 mm	15'8"
W Turning radius: inside of tires	2442 mm	8'0"	2442 mm	8'0"
X Rack angle at full lift	57°		59°	
Y Dump angle at full lift	48°		44°	
Z Rack angle at carry	42°		50°	
AA Departure angle	33°		33°	
BB Articulation angle	40°		40°	
Operating weight	7470 kg	16,463 lb	7979 kg	17,586 lb

*Varies with bucket.

**Varies with tires.

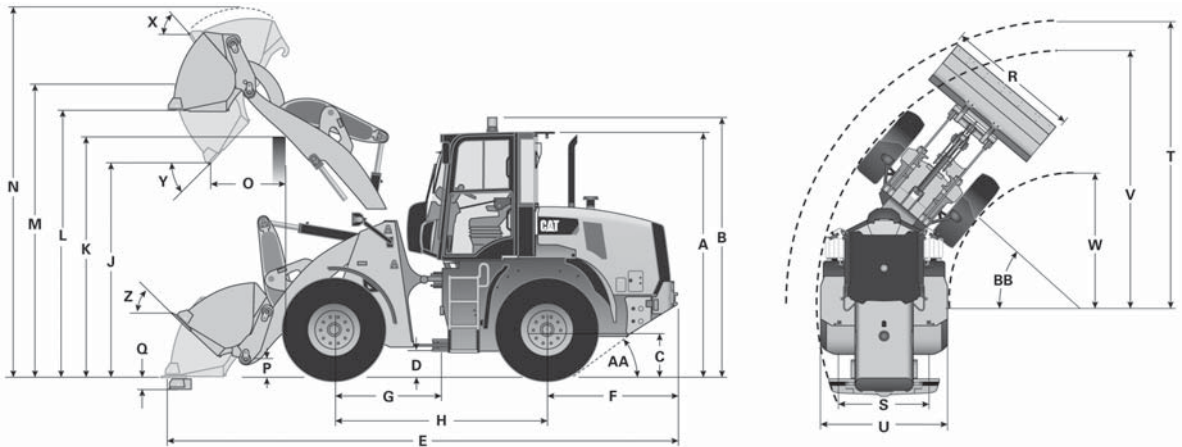

Dimensions listed are for a machine configured with general purpose pin on buckets, bolt-on cutting edges, full fuel tank, 80 kg (176 lb) operator, and standard tires.

All dimensions are approximate. Dimensions vary with bucket, couplers, and tire choice.

MODEL	914K		914K	
	Standard Lift and Pin On Bucket		High Lift and Pin On Bucket	
** A Height: ground to cab	3093 mm	10'1"	3093 mm	10'1"
** B Height: ground to beacon	3283 mm	10'9"	3283 mm	10'9"
** C Height: ground axle center	640 mm	2'1"	640 mm	2'1"
** D Height: ground clearance	405 mm	1'3"	405 mm	1'3"
* E Length: overall	6291 mm	20'7"	6834 mm	22'5"
F Length: rear axle to bumper	1600 mm	5'2"	1600 mm	5'2"
G Length: hitch to front axle	1300 mm	4'3"	1300 mm	4'3"
H Length: wheel base	2600 mm	8'6"	2600 mm	8'6"
* J Clearance: bucket at 45°	2820 mm	9'3"	3174 mm	10'4"
** K Clearance: load over height	3315 mm	10'10"	3429 mm	11'2"
** L Clearance: level bucket	3447 mm	11'3"	3800 mm	12'5"
** M Height: bucket pin	3701 mm	12'1"	4055 mm	13'3"
** N Height: overall	4621 mm	15'1"	4974 mm	16'3"
* O Reach: bucket at 45°	790 mm	2'7"	1009 mm	3'3"
P Carry height: bucket pin	317 mm	1'0"	483 mm	1'6"
** Q Dig depth	89 mm	3.4"	272 mm	10.7"
R Width: bucket	2401 mm	7'10"	2401 mm	7'10"
S Width: tread center	1800 mm	5'10"	1800 mm	5'10"
T Turning radius: over bucket	5200 mm	17'0"	5448 mm	17'10"
U Width: over tires	2259 mm	7'4"	2259 mm	7'4"
V Turning radius: outside of tires	4783 mm	15'8"	4783 mm	15'8"
W Turning radius: inside of tires	2442 mm	8'0"	2442 mm	8'0"
X Rack angle at full lift		57°		59°
Y Dump angle at full lift		48°		44°
Z Rack angle at carry		41°		49°
AA Departure angle		33°		33°
BB Articulation angle		40°		40°
Operating weight	8126 kg	17,910 lb	8181 kg	18,030 lb

*Varies with bucket.

**Varies with tires.

Wheel Loaders Integrated Toolcarriers

Machine Dimensions ● 914K

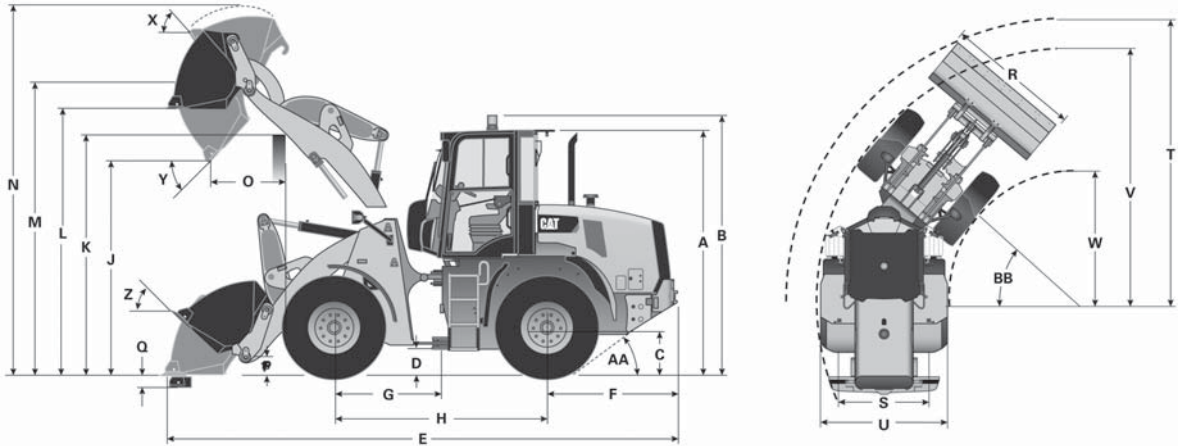

Dimensions listed are for a machine configured with general purpose pin on buckets, bolt-on cutting edges, full fuel tank, 80 kg (176 lb) operator, and standard tires.

All dimensions are approximate. Dimensions vary with bucket, couplers, and tire choice.

MODEL	914K		914K	
	Standard Lift and IT Bucket		High Lift and IT Bucket	
**A Height: ground to cab	3093 mm	10'1"	3093 mm	10'1"
**B Height: ground to beacon	3283 mm	10'9"	3283 mm	10'9"
**C Height: ground axle center	640 mm	2'1"	640 mm	2'1"
**D Height: ground clearance	405 mm	1'3"	405 mm	1'3"
*E Length: overall	6362 mm	20'10"	6905 mm	22'7"
F Length: rear axle to bumper	1600 mm	5'2"	1600 mm	5'2"
G Length: hitch to front axle	1300 mm	4'3"	1300 mm	4'3"
H Length: wheel base	2600 mm	8'6"	2600 mm	8'6"
*J Clearance: bucket at 45°	2775 mm	9'1"	3129 mm	10'3"
**K Clearance: load over height	3315 mm	10'10"	3429 mm	11'2"
**L Clearance: level bucket	3446 mm	11'3"	3800 mm	12'5"
**M Height: bucket pin	3701 mm	12'1"	4055 mm	13'3"
**N Height: overall	4674 mm	15'4"	5027 mm	16'5"
*O Reach: bucket at 45°	847 mm	2'9"	1066 mm	3'5"
P Carry height: bucket pin	317 mm	1'0"	483 mm	1'6"
**Q Dig depth	89 mm	3.5"	273 mm	10.7"
R Width: bucket	2401 mm	7'10"	2401 mm	7'10"
S Width: tread center	1800 mm	5'10"	1800 mm	5'10"
T Turning radius: over bucket	5222 mm	17'1"	5471 mm	17'11"
U Width: over tires	2259 mm	7'4"	2259 mm	7'4"
V Turning radius: outside of tires	4783 mm	15'8"	4783 mm	15'8"
W Turning radius: inside of tires	2442 mm	8'0"	2442 mm	8'0"
X Rack angle at full lift		57°		59°
Y Dump angle at full lift		48°		44°
Z Rack angle at carry		41°		49°
AA Departure angle		33°		33°
BB Articulation angle		40°		40°
Operating weight	8467 kg	18,666 lb	8521 kg	18,785 lb

*Varies with bucket.

**Varies with tires.

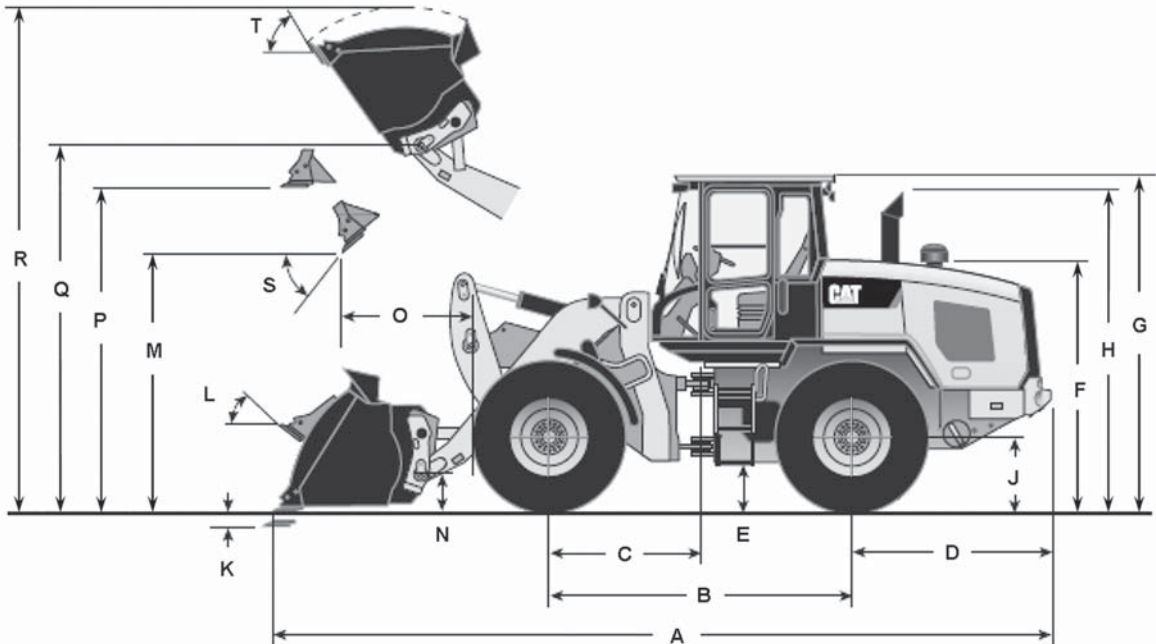

Dimensions listed are for a machine configured with Fusion general purpose bucket, bolt-on cutting edge, standard counterweight (924K), heavy counterweight (930K), additional guarding, 80 kg (176 lb) operator, and Michelin 20.5 R25 (L-3) XHA2 tires.

MODEL	926M*		926M*		930M*	
	Standard	High Lift	Standard	High Lift	Standard	High Lift
Bucket	1.9 m ³	2.5 yd ³	1.9 m ³	2.5 yd ³	2.1 m ³	2.8 yd ³
A Maximum overall length**	7451 mm	24'5"	8093 mm	26'7"	7530 mm	24'8"
B Wheel base	3000 mm	9'10"	3000 mm	9'10"	3000 mm	9'10"
C Machine center point to front axle	1500 mm	4'11"	1500 mm	4'11"	1500 mm	4'11"
D Rear axle to counterweight	1986 mm	6'6"	1986 mm	6'6"	1993 mm	6'6"
E Ground clearance***	397 mm	1'3"	397 mm	1'3"	397 mm	1'3"
F Height to top of engine compartment	2235 mm	7'4"	2235 mm	7'4"	2235 mm	7'4"
G Height to top of ROPS***	3340 mm	10'11"	3340 mm	10'11"	3340 mm	10'11"
H Height to top of stack	3223 mm	10'7"	3223 mm	10'7"	3223 mm	10'7"
J Tire Radius (empty machine)***	685 mm	2'3"	685 mm	2'3"	685 mm	2'3"
K Maximum digging depth (bucket level)***	100 mm	4"	135 mm	5"	100 mm	4"
L Maximum rollback at carry height	45°		49°		45°	
M Dump clearance at full lift and 45° discharge angle**	2885 mm	9'5"	3378 mm	11'0"	2828 mm	9'3"
N Hinge pin height at carry position	458 mm	1'6"	649 mm	2'2"	458 mm	1'6"
O Reach at full lift and 45° dump**	1024 mm	3'4"	1261 mm	4'1"	1064 mm	3'5"
P Clearance level bucket at full height***	3580 mm	11'9"	4073 mm	13'4"	3580 mm	11'9"
Q Maximum hinge pin height***	3907 mm	12'10"	4400 mm	14'5"	3907 mm	12'10"
R Maximum overall height***	5076 mm	16'7"	5569 mm	18'3"	5147 mm	16'10"
S Full dump at maximum lift	50°		49°		49°	
T Maximum roll back at maximum lift	54°		51°		54°	
Tires	20.5 R25 (L-3) XHA2		20.5 R25 (L-3) XHA2		20.5 R25 (L-3) XHA2	

*Meets Tier 4 Final/Stage IV/Japan 2014 (Tier 4 Final) emission standards.

**Varies with bucket.

***Varies with tire.

Wheel Loaders Integrated Toolcarriers

Machine Dimensions

● 930M*, 938M*

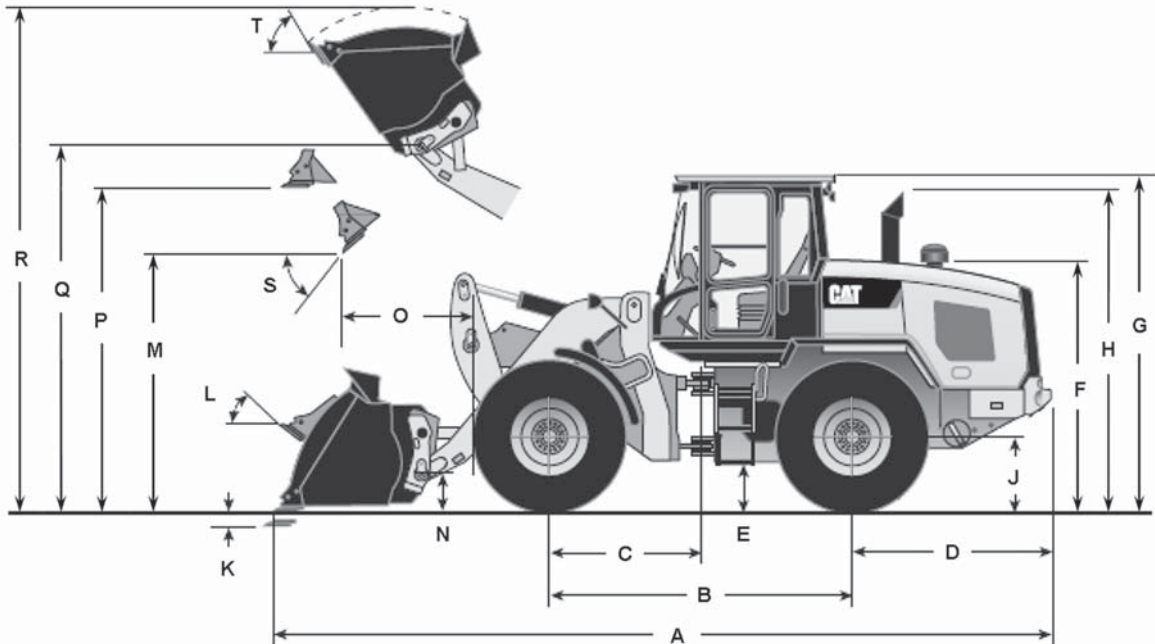

Dimensions listed are for a machine configured with Fusion general purpose bucket, bolt-on cutting edge, heavy counterweight, additional guarding, 80 kg (176 lb) operator, and Michelin 20.5 R25 (L-3) XHA2 tires.

MODEL	930M* High Lift		930M* Standard		938M* High Lift	
	Bucket	2.1 m ³	2.8 yd ³	2.5 m ³	3.3 yd ³	2.5 m ³
A Maximum overall length**	8324 mm	27'4"	7656 mm	25'1"	8397 mm	27'7"
B Wheel base	3000 mm	9'10"	3050 mm	10'0"	3050 mm	10'0"
C Machine center point to front axle	1500 mm	4'11"	1525 mm	5'0"	1525 mm	5'0"
D Rear axle to counterweight	1993 mm	6'6"	1968 mm	6'5"	1968 mm	6'5"
E Ground clearance***	397 mm	1'3"	386 mm	1'3"	386 mm	1'3"
F Height to top of engine compartment	2235 mm	7'4"	2235 mm	7'4"	2235 mm	7'4"
G Height to top of ROPS***	3340 mm	10'11"	3340 mm	10'11"	3340 mm	10'11"
H Height to top of stack	3223 mm	10'7"	3223 mm	10'7"	3223 mm	10'7"
J Tire Radius (empty machine)***	685 mm	2'3"	685 mm	2'3"	685 mm	2'3"
K Maximum digging depth (bucket level)***	135 mm	5"	100 mm	4"	135 mm	5"
L Maximum rollback at carry height		50°		45°		50°
M Dump clearance at full lift and 45° discharge angle**	3421 mm	11'2"	2834 mm	9'3"	3415 mm	11'2"
N Hinge pin height at carry position	692 mm	2'3"	467 mm	1'6"	686 mm	2'3"
O Reach at full lift and 45° dump**	1385 mm	4'6"	1146 mm	3'9"	1413 mm	4'7"
P Clearance level bucket at full height***	4073 mm	13'4"	3462 mm	11'4"	4223 mm	13'10"
Q Maximum hinge pin height***	4500 mm	14'9"	3969 mm	13'0"	4550 mm	14'11"
R Maximum overall height***	5740 mm	18'9"	5273 mm	17'3"	5853 mm	19'2"
S Full dump at maximum lift		48°		49°		47°
T Maximum roll back at maximum lift		53°		54°		53°
Tires	20.5 R25 (L-3) XHA2		20.5 R25 (L-3) XHA2		20.5 R25 (L-3) XHA2	

*Meets Tier 4 Final/Stage IV/Japan 2014 (Tier 4 Final) emission standards.

**Varies with bucket.

***Varies with tire.

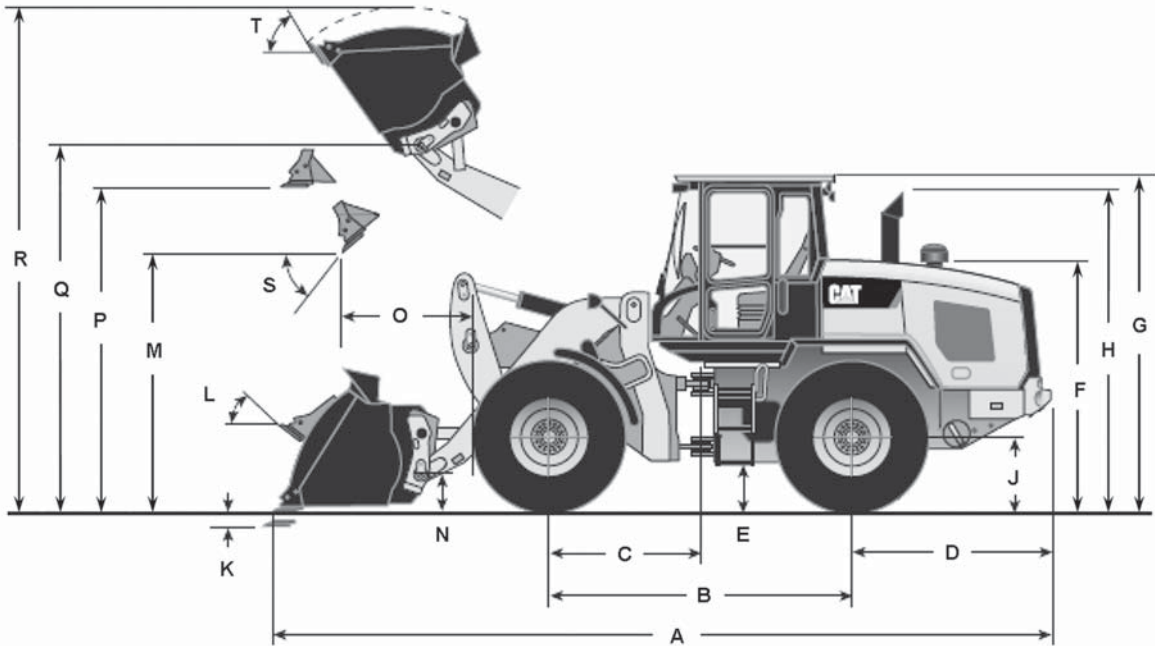

Dimensions listed are for a machine configured with general purpose pin on buckets, bolt-on cutting edges, optional counterweights, 80 kg (176 lb) operator, and Michelin 20.5 R25 (L-3) XHA2 tires.

MODEL	924K		930K		930K	
	Standard	Standard	Standard	Standard	High Lift	High Lift
Bucket	1.9 m ³	2.5 yd ³	2.1 m ³	2.7 yd ³	2.1 m ³	2.7 yd ³
A Maximum overall length*	7374 mm	24'2"	7488 mm	24'6"	8282 mm	27'2"
B Wheel base	3000 mm	9'10"	3000 mm	9'10"	3000 mm	9'10"
C Machine center point to front axle	1500 mm	4'11"	1500 mm	4'11"	1500 mm	4'11"
D Rear axle to counterweight	1986 mm	6'6"	1993 mm	6'6"	1993 mm	6'6"
E Ground clearance**	397 mm	1'3"	397 mm	1'3"	397 mm	1'3"
F Height to top of engine compartment	2235 mm	7'4"	2235 mm	7'4"	2235 mm	7'4"
G Height to top of ROPS**	3340 mm	10'11"	3340 mm	10'11"	3340 mm	10'11"
H Height to top of stack	3223 mm	10'7"	3223 mm	10'7"	3223 mm	10'7"
J Tire Radius (empty machine)**	685 mm	2'2"	685 mm	2'2"	685 mm	2'2"
K Maximum digging depth (bucket level)**	100 mm	3.9"	100 mm	3.9"	135 mm	5.3"
L Maximum rollback at carry height		43°		45°		51°
M Dump clearance at full lift and 45° discharge angle*	2857 mm	9'4"	2855 mm	9'4"	3448 mm	11'3"
N Hinge pin height at carry position	447 mm	1'5"	458 mm	1'6"	692 mm	2'3"
O Reach at full lift and 45° dump*	950 mm	3'1"	1033 mm	3'4"	1353 mm	4'5"
P Clearance level bucket at full height**	3526 mm	11'6"	3580 mm	11'8"	4173 mm	13'8"
Q Maximum hinge pin height**	3853 mm	12'7"	3907 mm	12'9"	4500 mm	14'9"
R Maximum overall height**	4997 mm	16'4"	5122 mm	16'9"	5715 mm	18'8"
S Full dump at maximum lift		50°		49°		48°
T Maximum roll back at maximum lift		53°		54°		53°
Tires	20.5 R25 (L-3) XHA2		20.5 R25 (L-3) XHA2		20.5 R25 (L-3) XHA2	

*Varies with bucket.

**Varies with tires.

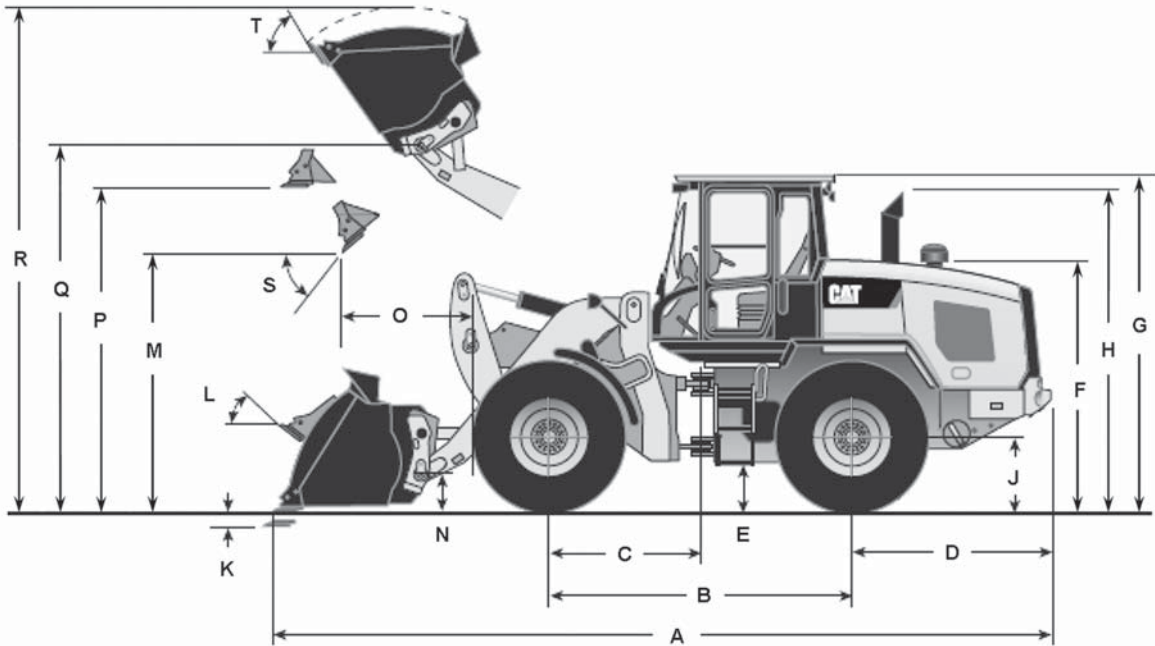

Dimensions listed are for a machine configured with general purpose pin on buckets, bolt-on cutting edges, optional counterweights, 80 kg (176 lb) operator, and Michelin 20.5 R25 (L-3) XHA2 tires.

MODEL	938K Standard		938K High Lift	
	Bucket	2.5 m ³	3.3 yd ³	2.5 m ³
A Maximum overall length*	7604 mm	24'11"	8344 mm	27'4"
B Wheel base	3050 mm	10'0"	3050 mm	10'0"
C Machine center point to front axle	1525 mm	5'0"	1525 mm	5'0"
D Rear axle to counterweight	1968 mm	6'5"	1968 mm	6'5"
E Ground clearance**	386 mm	1'3"	386 mm	1'3"
F Height to top of engine compartment	2235 mm	7'4"	2235 mm	7'4"
G Height to top of ROPS**	3340 mm	10'11"	3340 mm	10'11"
H Height to top of stack	3223 mm	10'7"	3223 mm	10'7"
J Tire Radius (empty machine)**	685 mm	2'2"	685 mm	2'2"
K Maximum digging depth (bucket level)**	100 mm	3.9"	135 mm	5.3"
L Maximum rollback at carry height		45°		50°
M Dump clearance at full lift and 45° discharge angle*	2869 mm	9'4"	3450 mm	11'3"
N Hinge pin height at carry position	467 mm	1'6"	686 mm	2'2"
O Reach at full lift and 45° dump*	1108 mm	3'7"	1374 mm	4'6"
P Clearance level bucket at full height**	3642 mm	11'11"	4223 mm	13'10"
Q Maximum hinge pin height**	3969 mm	13'0"	4550 mm	14'11"
R Maximum overall height**	5242 mm	17'2"	5823 mm	19'1"
S Full dump at maximum lift		49°		47°
T Maximum roll back at maximum lift		54°		53°
Tires	20.5 R25 (L-3) XHA2		20.5 R25 (L-3) XHA2	

*Varies with bucket.

**Varies with tires.

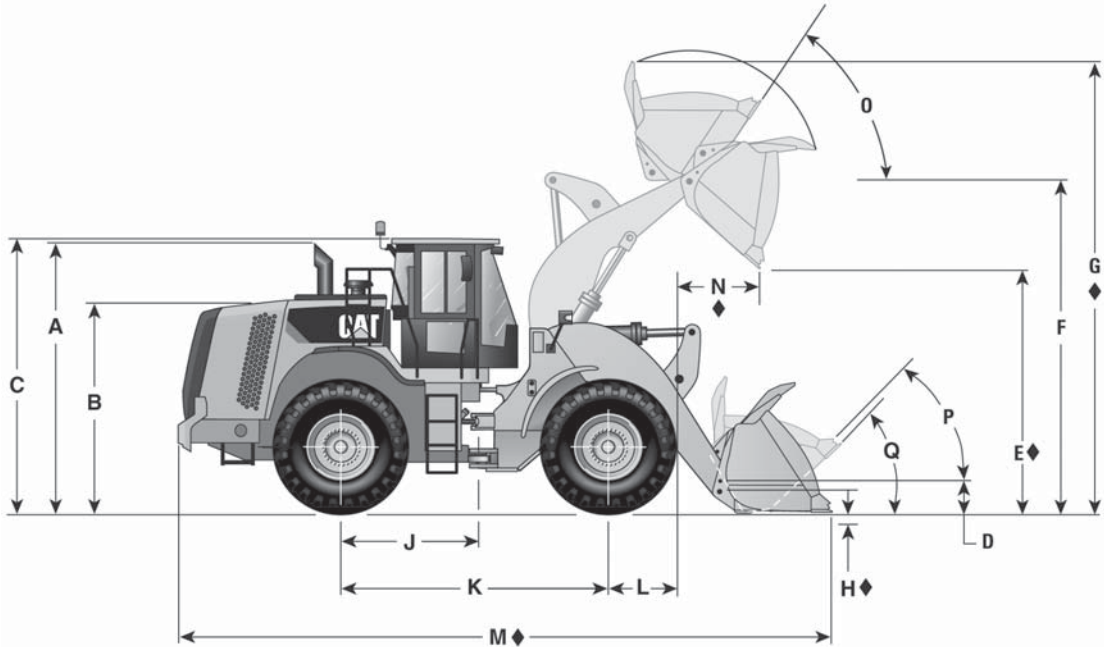

Dimensions shown represent standard machine with bucket, bolt-on cutting edge, and standard tires.

◆ Varies with Bucket Size and/or Bucket Configuration — Refer to Performance Data.

MODEL	950M General Purpose Bolt-on Edges		962M General Purpose Bolt-on Edges	
	3.1 m ³	4.0 yd ³	3.3 m ³	4.3 yd ³
A Height to top of exhaust pipe	3427 mm	11'3"	3424 mm	11'3"
B Height to top of engine compartment	2697 mm	8'10"	2694 mm	8'10"
C Height to top of ROPS	3446 mm	11'4"	3443 mm	11'4"
D Hinge pin height at carry position	659 mm	26"	690 mm	27"
◆ E Dump clearance at full lift and 45° discharge angle	2876 mm	9'5"	3055 mm	10'0"
F Hinge pin height at full lift	4021 mm	13'2"	4237 mm	13'10"
◆ G Maximum overall height	5524 mm	18'2"	5787 mm	19'0"
◆ H Maximum digging depth	90 mm	3.5"	88 mm	3.5"
J Machine center point to axle	1675 mm	5'6"	1675 mm	5'6"
K Wheel base	3350 mm	11'0"	3350 mm	11'0"
L Radius of tire	746 mm	29"	746 mm	29"
◆ M Maximum overall length	8199 mm	26'11"	8574 mm	28'2"
◆ N Reach at full lift	1429 mm	4'8"	1392 mm	4'6"
O Maximum rollback at maximum lift		59°		55°
P Maximum rollback at carry height		46°		51°
Q Maximum rollback at ground		45°		46°
Ground clearance (std. tires)	385 mm	1'3"	385 mm	1'3"
Tread width (std. tires)	2140 mm	7'0"	2140 mm	7'0"
Width over tires (std. tires)	2790 mm	9'2"	2790 mm	9'2"
Tires used for measurements	L3 Michelin XHA2		L3 Michelin XHA2	

These machines are only available in certain regions. Contact your local Cat dealer for product availability.

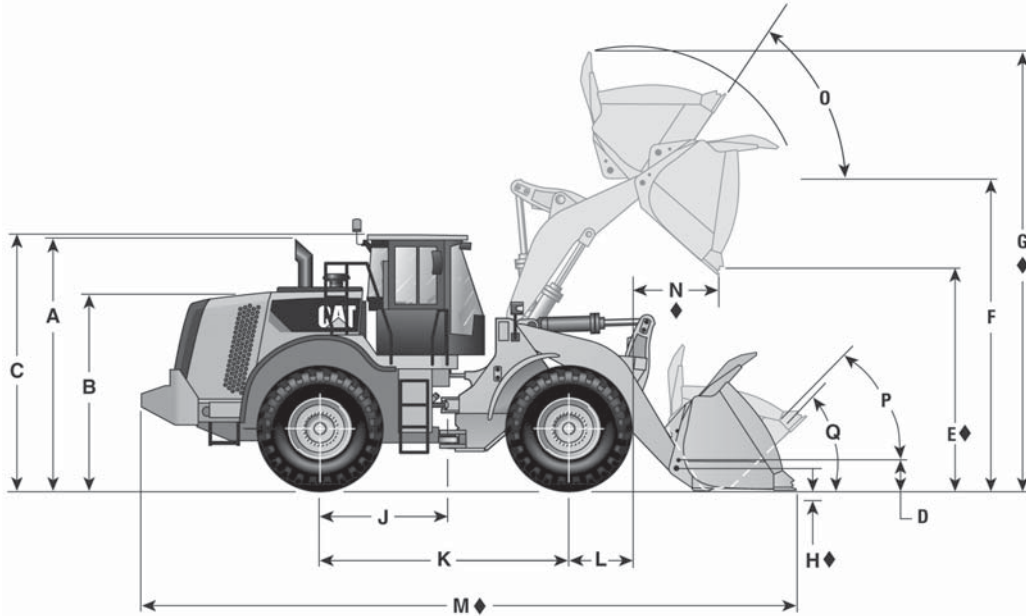

Dimensions shown represent standard machine with bucket, bolt-on cutting edge, and standard tires.

◆ Varies with Bucket Size and/or Bucket Configuration — Refer to Performance Data.

MODEL	966M/966M XE General Purpose Bolt-on Edges		972M/972M XE General Purpose Bolt-on Edges	
	4.2 m ³	5.49 yd ³	4.8 m ³	6.3 yd ³
A Height to top of exhaust pipe	3522 mm	11'7"	3522 mm	11'7"
B Height to top of engine compartment	2818 mm	9'3"	2818 mm	9'3"
C Height to top of ROPS	3559 mm	11'8"	3559 mm	11'8"
D Hinge pin height at carry position	630 mm	2'1"	680 mm	2'3"
◆ E Dump clearance at full lift and 45° discharge angle	2991 mm	9'9"	3154 mm	10'4"
F Hinge pin height at full lift	4235 mm	13'11"	4458 mm	14'8"
◆ G Maximum overall height	5902 mm	19'5"	6031 mm	19'10"
◆ H Maximum digging depth	124 mm	5"	103 mm	4"
J Machine center point to axle	1775 mm	5'10"	1775 mm	5'10"
K Wheel base	3550 mm	11'8"	3550 mm	11'8"
L Radius of tire	799 mm	2'7"	799 mm	2'7"
◆ M Maximum overall length	8750 mm	28'9"	9315 mm	30'7"
◆ N Reach at full lift	1353 mm	4'5"	1357 mm	4'5"
O Maximum rollback at maximum lift		62°		56°
P Maximum rollback at carry height		50°		50°
Q Maximum rollback at ground		42°		41°
Ground clearance (std. tires)	476 mm	1'7"	476 mm	1'7"
Tread width (std. tires)	2230 mm	7'4"	2230 mm	7'4"
Width over tires (std. tires)	2991 mm	9'10"	2991 mm	9'10"
Tires used for measurements	L3 Michelin XHA2		L3 Michelin XHA3	

These machines are only available in certain regions. Contact your local Cat dealer for product availability.

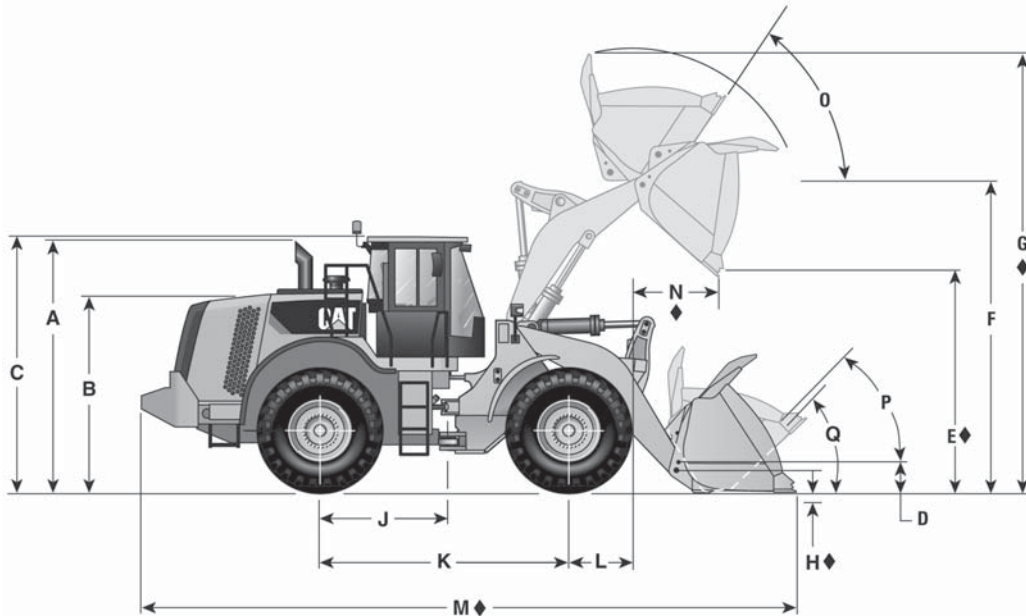

Dimensions shown represent standard machine with bucket, bolt-on cutting edge, and standard tires.

◆ Varies with Bucket Size and/or Bucket Configuration — Refer to Performance Data.

MODEL	980M General Purpose Bolt-on Edges		982M General Purpose Bolt-on Edges	
	5.4 m ³	7.1 yd ³	6.1 m ³	8.0 yd ³
A Height to top of exhaust pipe	3746 mm	12'4"	3719 mm	12'3"
B Height to top of engine compartment	3110 mm	10'3"	3083 mm	10'2"
C Height to top of ROPS	3813 mm	12'7"	3786 mm	12'6"
D Hinge pin height at carry position	621 mm	2'1"	790 mm	2'8"
◆ E Dump clearance at full lift and 45° discharge angle	3273 mm	10'9"	3365 mm	11'1"
F Hinge pin height at full lift	4539 mm	14'11"	4743 mm	15'7"
◆ G Maximum overall height	6421 mm	21'1"	6592 mm	21'8"
◆ H Maximum digging depth	103 mm	5"	116 mm	5"
J Machine center point to axle	1900 mm	6'3"	1900 mm	6'3"
K Wheel base	3800 mm	12'6"	3800 mm	12'6"
L Radius of tire	885 mm	2'11"	857 mm	2'10"
◆ M Maximum overall length	9493 mm	31'2"	10 177 mm	33'5"
◆ N Reach at full lift	1481 mm	4'11"	1569 mm	5'2"
O Maximum rollback at maximum lift		61°		57°
P Maximum rollback at carry height		48°		48°
Q Maximum rollback at ground		40°		42°
Ground clearance (std. tires)	453 mm	1'6"	426 mm	1'5"
Tread width (std. tires)	2440 mm	8'0"	2540 mm	8'4"
Width over tires (std. tires)	3265 mm	10'9"	3452 mm	11'4"
Tires used for measurements	L4 Michelin XLDD1		L4 Bridgestone VLTS	

These machines are only available in certain regions. Contact your local Cat dealer for product availability.

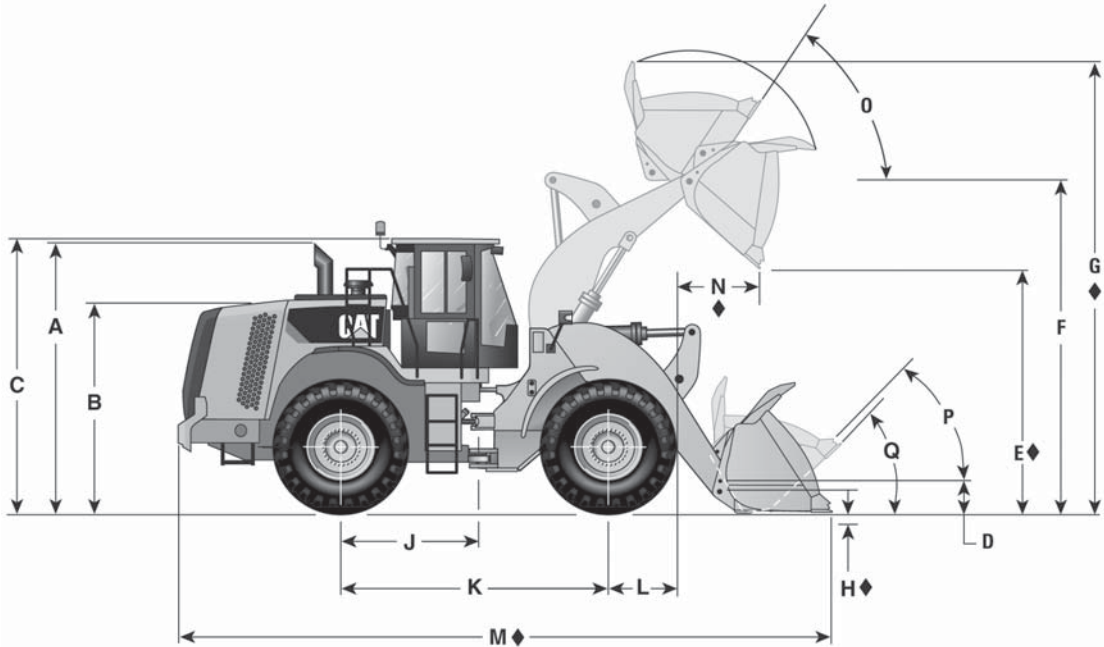

Dimensions shown represent standard machine with bucket, bolt-on cutting edge, and standard tires.

◆ Varies with Bucket Size and/or Bucket Configuration — Refer to Performance Data.

MODEL	950K General Purpose Bolt-on Edges		962K General Purpose Bolt-on Edges	
	3.1 m ³	4 yd ³	3.3 m ³	4.3 yd ³
A Height to top of exhaust pipe	3099 mm	10'2"	3099 mm	10'2"
B Height to top of engine compartment	2415 mm	7'11"	2415 mm	7'11"
C Height to top of ROPS	3356 mm	11'0"	3356 mm	11'0"
D Hinge pin height at carry position	659 mm	26"	677 mm	27"
◆ E Dump clearance at full lift and 45° discharge angle	2876 mm	9'5"	3054 mm	10'0"
F Hinge pin height at full lift	4021 mm	13'2"	4237 mm	13'10"
◆ G Maximum overall height	5525 mm	18'2"	5788 mm	19'0"
◆ H Maximum digging depth	90 mm	3.5"	88 mm	3.5"
J Machine center point to axle	1675 mm	5'6"	1675 mm	5'6"
K Wheel base	3350 mm	10'11"	3350 mm	10'11"
L Radius of tire	746 mm	29"	746 mm	29"
◆ M Maximum overall length	8162 mm	26'10"	8482 mm	27'10"
◆ N Reach at full lift	1429 mm	4'8"	1392 mm	4'6"
O Maximum rollback at maximum lift		59°		55°
P Maximum rollback at carry height		46°		51°
Q Maximum rollback at ground		45°		46°
Ground clearance (std. tires)	397 mm	1'3"	397 mm	1'3"
Tread width (std. tires)	2.14 m	7'0"	2.14 m	7'0"
Width over tires (std. tires)	2.78 m	9'1"	2.78 m	9'1"
Tires used for measurements	L3 Michelin XHA2		L3 Michelin XHA2	

These machines are only available in certain regions. Contact your local Cat dealer for product availability.

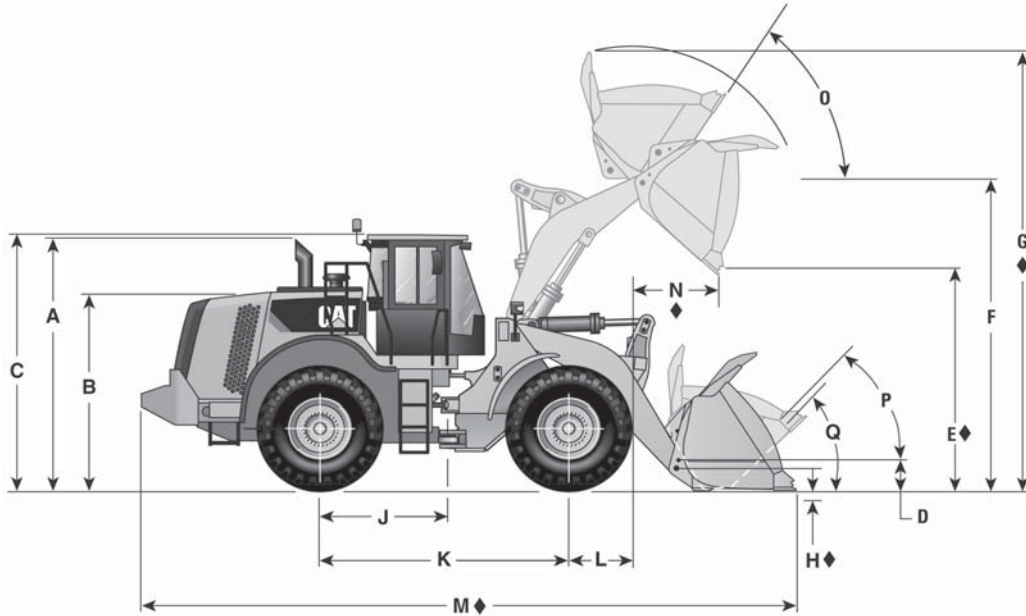

Dimensions shown represent standard machine with bucket, bolt-on cutting edge, and standard tires.

◆ Varies with Bucket Size and/or Bucket Configuration — Refer to Performance Data.

MODEL	966K General Purpose Bolt-on Edges		972K General Purpose Bolt-on Edges		980K General Purpose Bolt-on Edges	
	4.2 m ³	5.49 yd ³	4.8 m ³	6.3 yd ³	5.4 m ³	7.1 yd ³
A Height to top of exhaust pipe	3518 mm	11'6"	3518 mm	11'6"	3737 mm	12'4"
B Height to top of engine compartment	2828 mm	9'3"	2828 mm	9'3"	3109 mm	10'2"
C Height to top of ROPS	3547 mm	11'7"	3547 mm	11'7"	3809 mm	12'6"
D Hinge pin height at carry position	640 mm	2'1"	689 mm	2'3"	673 mm	2'0"
◆ E Dump clearance at full lift and 45° discharge angle	2991 mm	9'9"	3154 mm	10'4"	3273 mm	10'8"
F Hinge pin height at full lift	4234 mm	13'10"	4456 mm	14'7"	4539 mm	14'11"
◆ G Maximum overall height	5902 mm	19'5"	6031 mm	19'10"	6421 mm	21'1"
◆ H Maximum digging depth	124 mm	4.9"	103 mm	4"	103 mm	4"
J Machine center point to axle	2187 mm	7'2"	2473 mm	8'1"	1850 mm	6'1"
K Wheel base	3450 mm	11'3"	3450 mm	11'3"	3700 mm	12'1"
L Radius of tire	799 mm	31"	800 mm	31"	885 mm	35"
◆ M Maximum overall length	8691 mm	28'7"	9223 mm	30'4"	9509 mm	31'3"
◆ N Reach at full lift	1388 mm	4'6"	1392 mm	4'6"	1556 mm	5'1"
O Maximum rollback at maximum lift		62°		56°		61°
P Maximum rollback at carry height		50°		50°		49°
Q Maximum rollback at ground		42°		41°		41°
Ground clearance (std. tires)	475 mm	1'6"	475 mm	1'6"	460 mm	1'6"
Tread width (std. tires)	2.23 m	7'4"	2.23 m	7'4"	2.44 m	8'0"
Width over tires (std. tires)	3.00 m	9'10"	3.00 m	9'10"	3.25 m	10'8"
Tires used for measurements	L3 Michelin XHA2		L3 Michelin XHA3		L4 Michelin XLDD1	

These machines are only available in certain regions. Contact your local Cat dealer for product availability.

Wheel Loaders Integrated Toolcarriers

Machine Dimensions

● 950 GC, 950H, 962H

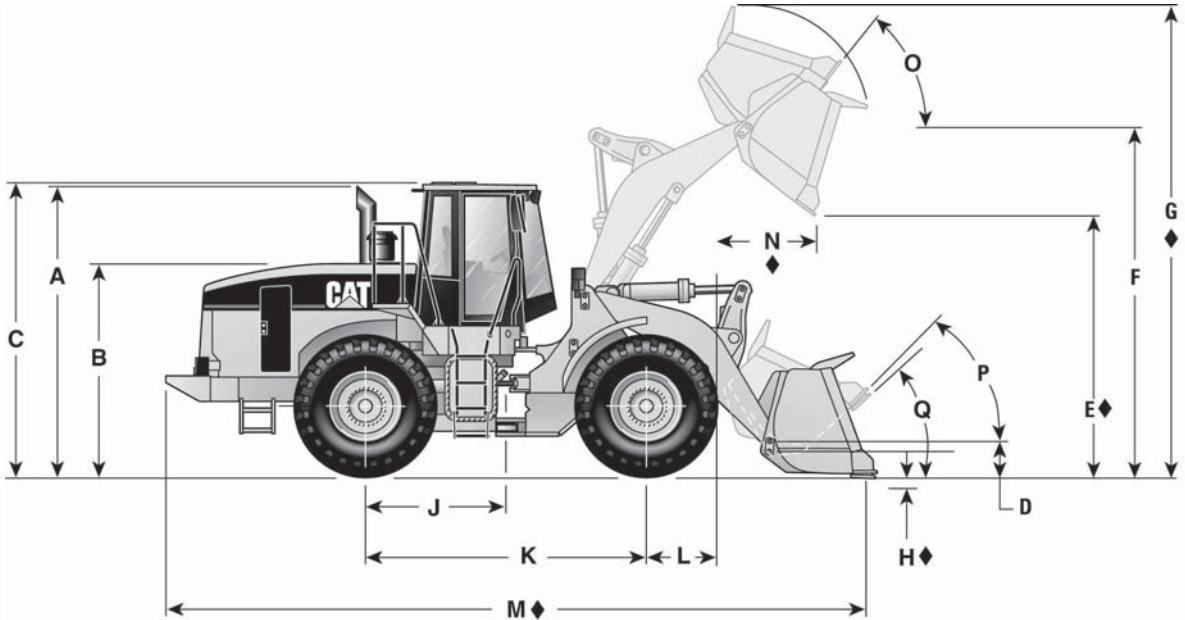

Dimensions shown represent standard machine with bucket, bolt-on cutting edge, and standard tires.

◆ Varies with Bucket Size and/or Bucket Configuration — Refer to Performance Data.

MODEL	950 GC General Purpose Bolt-on Edges		950H General Purpose Bolt-on Edges		962H General Purpose Bolt-on Edges	
	3.3 m ³	4.3 yd ³	3.1 m ³	4 yd ³	3.5 m ³	4.5 yd ³
A Height to top of exhaust pipe	3596 mm	11'9"	3278 mm	10'8"	3278 mm	10'8"
B Height to top of engine compartment	2568 mm	8'5"	2448 mm	8'0"	2448 mm	8'0"
C Height to top of ROPS	3458 mm	11'4"	3461 mm	11'4"	3461 mm	11'4"
D Hinge pin height at carry position	655 mm	2'1"	624 mm	2'0"	664 mm	2'2"
◆ E Dump clearance at full lift and 45° discharge angle	3012 mm	9'10"	2936 mm	9'7"	3046 mm	9'11"
F Hinge pin height at full lift	4188 mm	13'8"	3992 mm	13'1"	4182 mm	13'7"
◆ G Maximum overall height	5693 mm	18'8"	5363 mm	17'8"	5515 mm	18'2"
◆ H Maximum digging depth	86 mm	3"	89 mm	3.5"	90 mm	3.5"
J Machine center point to axle	1650 mm	5'4"	1675 mm	5'5"	1675 mm	5'5"
K Wheel base	3300 mm	10'9"	3350 mm	11'0"	3350 mm	11'0"
L Radius of tire	750 mm	2'5"	746 mm	2'5"	746 mm	2'5"
◆ M Maximum overall length	8288 mm	27'2"	7961 mm	26'2"	8291 mm	27'3"
◆ N Reach at full lift	1292 mm	4'2"	1263 mm	4'1"	1269 mm	4'1"
O Maximum rollback at maximum lift		60°		59.5°		59.5°
P Maximum rollback at carry height		45°		49.4°		48.5°
Q Maximum rollback at ground		40°		41°		40°
Ground clearance (std. tires)	460 mm	1'6"	397 mm	1'3"	397 mm	1'3"
Tread width (std. tires)	2150 mm	7'0"	2140 mm	7'0"	2140 mm	7'0"
Width over tires (std. tires)	2751 mm	9'0"	2784 mm	11'0"	2784 mm	11'0"
Tires used for measurements	L3 Triangle TB516		23.5R25 L3 Michelin XHA2		23.5R25 L3 Michelin XHA2	

These machines are only available in certain regions. Contact your local Cat dealer for product availability.

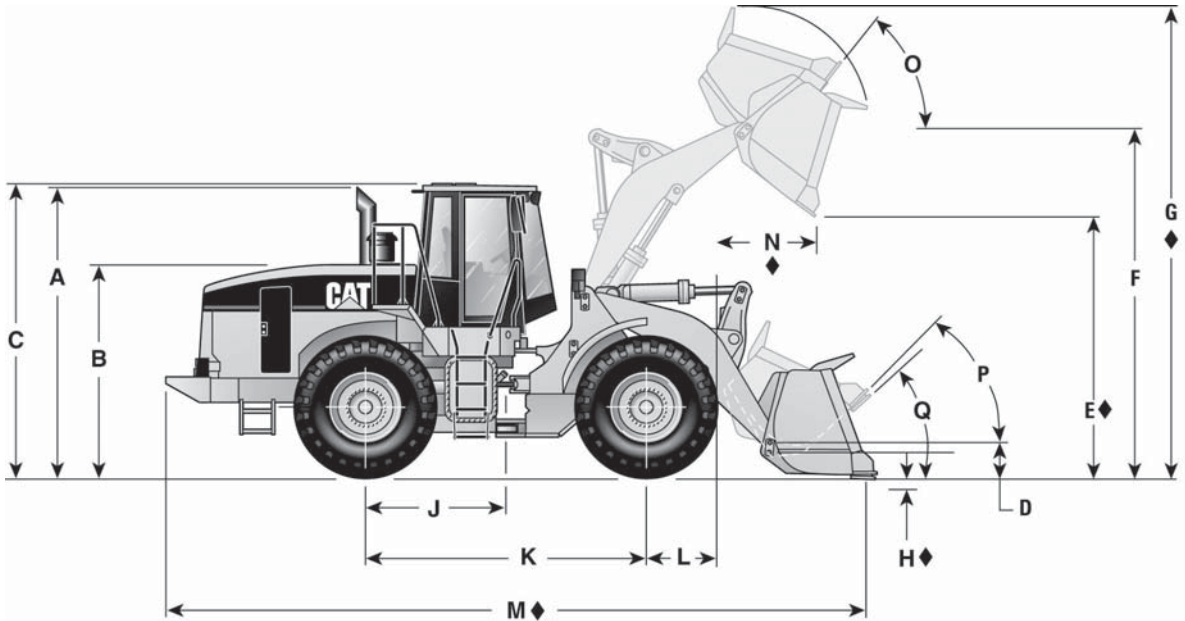

Dimensions shown represent standard machine with general purpose bucket and standard tires.

◆ Varies with Bucket Size and/or Bucket Configuration — Refer to Performance Data.

MODEL	966H General Purpose Bolt-on Edges		972H General Purpose Bolt-on Edges		980H General Purpose Bolt-on Edges	
	4.0 m ³	5.2 yd ³	4.6 m ³	6.0 yd ³	5.4 m ³	7.1 yd ³
A Height to top of stack	3524 mm	11'6"	3524 mm	11'6"	3714 mm	12'2"
B Height to top of engine compartment	2655 mm	8'8"	2655 mm	8'8"	2721 mm	8'11"
C Height to top of ROPS	3575 mm	11'8"	3575 mm	11'8"	3776 mm	12'4"
D Hinge pin height at carry position	641 mm	25"	691 mm	27"	644 mm	25"
◆ E Dump clearance at full lift and 45° discharge angle	3058 mm	10'0"	3187 mm	10'5"	3242 mm	10'7"
F Hinge pin height at full lift	4235 mm	13'10"	4458 mm	14'7"	4509 mm	14'9"
◆ G Maximum overall height	5902 mm	19'5"	6195 mm	20'4"	6391 mm	21'0"
◆ H Maximum digging depth	124 mm	5"	103 mm	4"	133 mm	5"
J Machine center point to axle	1725 mm	5'7"	1725 mm	5'7"	1850 mm	6'1"
K Wheel base	3450 mm	11'3"	3450 mm	11'3"	3700 mm	12'2"
L Radius of tire	799 mm	2'8"	799 mm	2'8"	855 mm	2'9"
◆ M Maximum overall length	8693 mm	28'7"	9177 mm	30'2"	9637 mm	31'8"
◆ N Reach at full lift	1334 mm	4'4"	1363 mm	4'5"	1580 mm	5'2"
O Maximum rollback at maximum lift		61°		55°		61°
P Maximum rollback at carry height		50°		50°		49°
Q Maximum rollback at ground		42°		41°		41°
Ground clearance (std. tires)	434 mm	1'5"	434 mm	1'5"	430 mm	1'4"
Tread width (std. tires)	2233 mm	7'3"	2233 mm	7'3"	2428 mm	8'0"
Width over tires (std. tires)	2914 mm	9'6"	2914 mm	9'6"	3175 mm	10'5"
Tires used for measurements	26.5R25 L3 Michelin XHA2		26.5R25 L3 Michelin XHA2		29.5R25 L3 Michelin XHA2	

These machines are only available in certain regions. Contact your local Cat dealer for product availability.

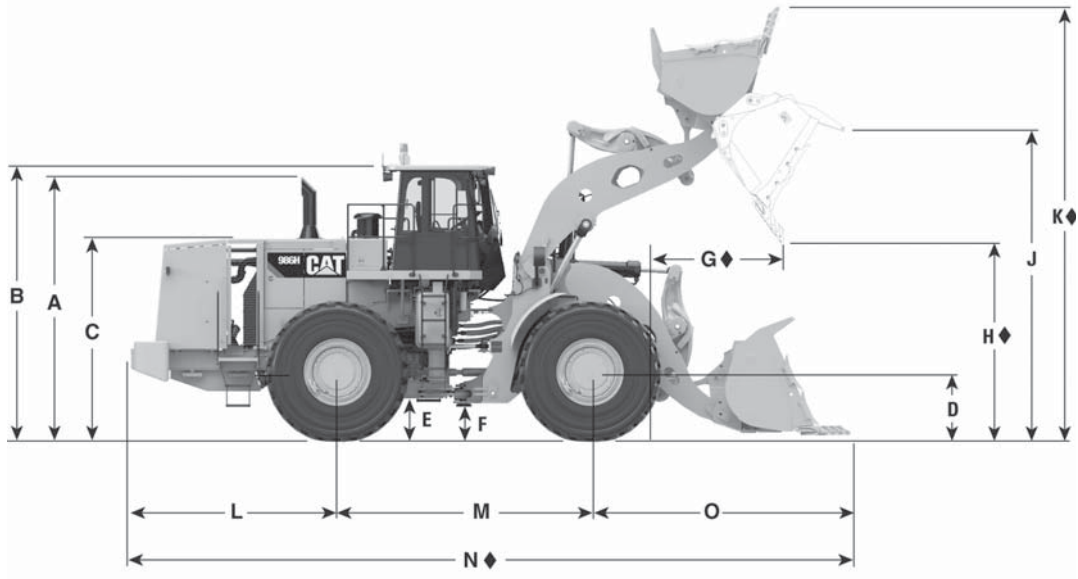

◆ Varies with Bucket Size and/or Bucket Configuration — Refer to Performance Data.

MODEL	986H Standard Lift		986H High Lift	
	A	3940 mm	12.9'	3940 mm
B	4110 mm	13.5'	4110 mm	13.5'
C	2991 mm	9.8'	2991 mm	9.8'
D	978 mm	3.2'	978 mm	3.2'
E	691 mm	2.3'	691 mm	2.3'
F	459 mm	1.5'	459 mm	1.5'
◆ G	2022 mm	6.6'	1904 mm	6.2'
◆ H	3234 mm	10.6'	3738 mm	12.3'
J	4912 mm	16.1'	5371 mm	17.6'
◆ K	6671 mm	21.9'	7067 mm	23.2'
L	3132 mm	10.3'	3132 mm	10.3'
M	3810 mm	12.5'	3810 mm	12.5'
◆ N	10 907 mm	35.8'	11 290 mm	37.0'
O	3987 mm	13.1'	4370 mm	14.3'

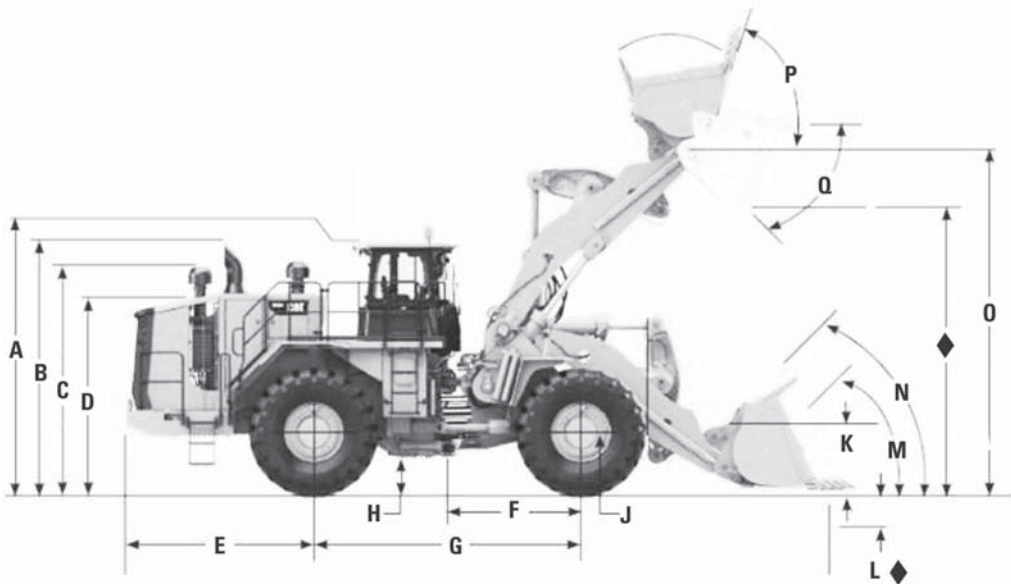

◆ Dimensions vary with bucket. Refer to Operation/Bucket Specifications.

MODEL	988K High Lift	
A Height to top of cab	4221 mm	13.8'
B Height to top of exhaust stack	4214 mm	13.8'
C Height to top of air cleaner	3881 mm	12.7'
D Height to top of hood	3329 mm	10.9'
E Center line of rear axle to edge of rear bumper	3187 mm	10.5'
F Center line of front axle to hitch	2275 mm	7.46'
G Wheel base length	4550 mm	14.93'
H Ground clearance	568 mm	1.9'
J Height to center of wheel	973 mm	3.2'
K C-pin height**	944 mm	3.1'
L Dig depth	220 mm	9"
	204 mm*	8"
M Rack back angle at ground	44.7°	
	43.6°*	
N Rack back angle at carry	52.9°	
	51°*	
O B-pin height	5881 mm	19.3'
	5479 mm*	18.0'
P Rack back angle at maximum lift	64.3°	
Q Dump angle at maximum lift	-50.1°	

*Standard Lift.

Wheel Loaders Integrated Toolcarriers

Machine Dimensions

- 988K
- Tire Dimensions/Specifications

Tire Dimensions/Specifications	Width over Tires		Ground Clearance		Change in Vertical Dimensions		Change in Full Turn Static Tipping Load	
	mm	in	mm	in	mm	in	kg	lb
35/65R33 (L-4) Michelin XLDD1	3598	140.1	526	20.7	0	0	0	0
35/65-33 42 PR (L-5) Bridgestone D-Lug	3541	139.4	565	22.2	39	1.5	1855	4090
35/65R33 (L-4) Bridgestone V-Steel N Traction VSNT	3569	140.5	541	21.3	15	0.6	287	633
35/65R33 (L-5) Bridgestone V-Steel D-Lug VSDL	3540	139.4	541	21.3	15	0.6	911	2008
35/65-33 42PR (L-5) Goodyear NRL D/L 5A	3487	137.3	553	21.8	27	1.1	2144	4727
875/65R33 (L-5) RL-5K	3536	139.2	543	21.4	17	0.7	1036	2284
35/65R33 (L-5) Michelin XLDD2	3549	139.7	536	21.1	10	0.4	242	534

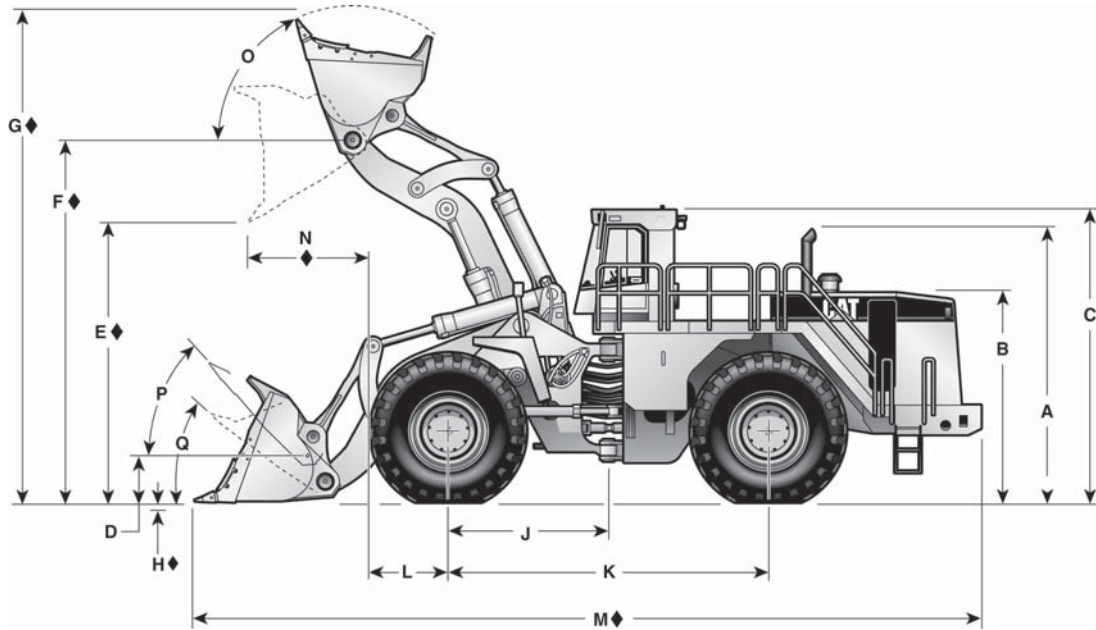

Dimensions shown represent standard machine with spade edge rock bucket and standard tires.

◆ Varies with Bucket Size and/or Bucket Configuration – Refer to Performance Data

MODEL	990K Spade Edge Rock with Teeth		990K High Lift Spade Edge Rock with Teeth		992K Spade Edge Rock with Teeth		992K High Lift Spade Edge Rock with Teeth	
	8.5 m ³	11.1 yd ³	8.5 m ³	11.1 yd ³	12.3 m ³	16.0 yd ³	10.7 m ³	14 yd ³
A Height to top of stack	5.05 m	16.6'	5.05 m	16.6'	5.24 m	17'2"	5.24 m	17'2"
B Height to top of engine compartment	3.86 m	12.7'	3.86 m	12.7'	4.0 m	13'1"	4.0 m	13'1"
C Height to top of ROPS	5.24 m	17.2'	5.24 m	17.2'	5.67 m	18'7"	5.67 m	18'7"
D Hinge pin height at carry position	853 mm	2.8'	1060 mm	3.5'	1209 mm	4'0"	1339 mm	4'5"
◆ E Dump clearance at full lift and 45° discharge angle	4.06 m	13.3'	4.52 m	14.8'	4.49 m	14'9"	5.22 m	17'2"
◆ F Hinge pin height at full lift	6.01 m	19.7'	6.47 m	21.2'	6.92 m	22'8"	7.54 m	24'9"
◆ G Maximum overall height	8.29 m	27.2'	8.75 m	28.7'	9.49 m	31'2"	9.93 m	32'7"
◆ H Maximum digging depth	130 mm	5"	172 mm	7"	201 mm	8"	176 mm	7"
K Machine center point to axle	2.3 m	7.5'	2.3 m	7.5'	2.94 m	9'8"	2.94 m	9'8"
J Wheel base	4.6 m	15.1'	4.6 m	15.1'	5.89 m	19'4"	5.89 m	19'4"
L Radius of tire	1.29 m	4.2'	1.29 m	4.2'	1.37 m	4'6"	1.37 m	4'6"
◆ M Maximum overall length	13.07 m	42.9'	13.81 m	45.3'	15.9 m	52'2"	16.2 m	53'2"
◆ N Reach at full lift	2.19 m	7.2'	2.59 m	8.5'	2.43 m	8'0"	2.19 m	7'2"
O Maximum rollback at maximum lift	63.7°		60.6°		65°		65°	
P Maximum rollback at carry height	48.8°		49.3°		52.7°		52.5°	
Q Maximum rollback at ground	40.4°		39.9°		43.4°		42.8°	
Ground clearance (std. tires)	596 mm	2.0'	596 mm	2.0'	682 mm	26.8"	682 mm	26.8"
Tread width (std. tires)	3.05 m	10'	3.05 m	10'	3.30 m	10'10"	3.30 m	10'10"
Width over tires (std. tires)	4.24 m	13.9'	4.24 m	13.9'	4.50 m	14'9"	4.50 m	14'9"
Tires used for measurements	45/65R39 VSDL SLR: 1203 mm		45/65R39 VSDL SLR: 1203 mm		—		—	

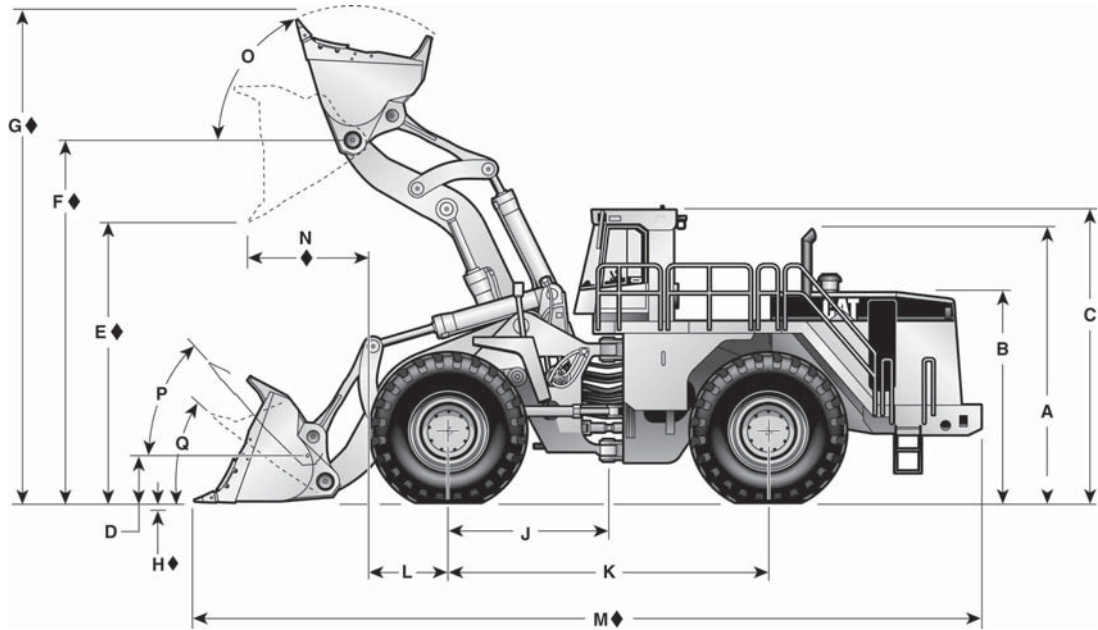

Dimensions shown represent standard machine with spade edge rock bucket and standard tires.

◆ Varies with Bucket Size and/or Bucket Configuration — Refer to Performance Data

MODEL	993K Standard Lift Spade Edge Rock with Teeth & Segments		993K High Lift Spade Edge Rock with Teeth & Segments	
	13 m ³	17 yd ³	13 m ³	17 yd ³
A Height to top of stack	5.45 m	17'9"	5.45 m	17'9"
B Height to top of engine compartment	4.25 m	14'0"	4.25 m	14'0"
C Height to top of ROPS	6.00 m	19'7"	6.00 m	19'7"
D Hinge pin height at carry position	1009 mm	39.7"	1185 mm	46.7"
◆ E Dump clearance at full lift and 45° discharge angle	4.65 m	15'3"	5.29 m	17'4"
F Hinge pin height at full lift	7.00 m	23'0"	7.64 m	25'1"
◆ G Maximum overall height	9.79 m	32'1"	10.43 m	34'0"
◆ H Maximum digging depth	181 mm	7"	246 mm	10"
J Machine center point to axle	2.94 m	9'8"	2.94 m	9'8"
K Wheel base	5.89 m	19'4"	5.89 m	19'4"
L Radius of tire	1.34 m	4'4"	1.34 m	4'4"
◆ M Maximum overall length	15.21 m	50'0"	15.84 m	52'0"
◆ N Reach at full lift	2.50 m	8'2"	2.61 m	8'6"
O Maximum rollback at maximum lift		63.9°		65.7°
P Maximum rollback at carry height		52.5°		53.5°
Q Maximum rollback at ground		46.3°		46.1°
Ground clearance (std. tires)	590 mm	2'0"	590 mm	2'0"
Tread width (std. tires)	3.54 m	11'6"	3.54 m	11'6"
Width over tires (std. tires)	4.93 m	16'2"	4.93 m	16'2"
Tires used for measurements	50/65-51 (L-5)		50/65-51 (L-5)	

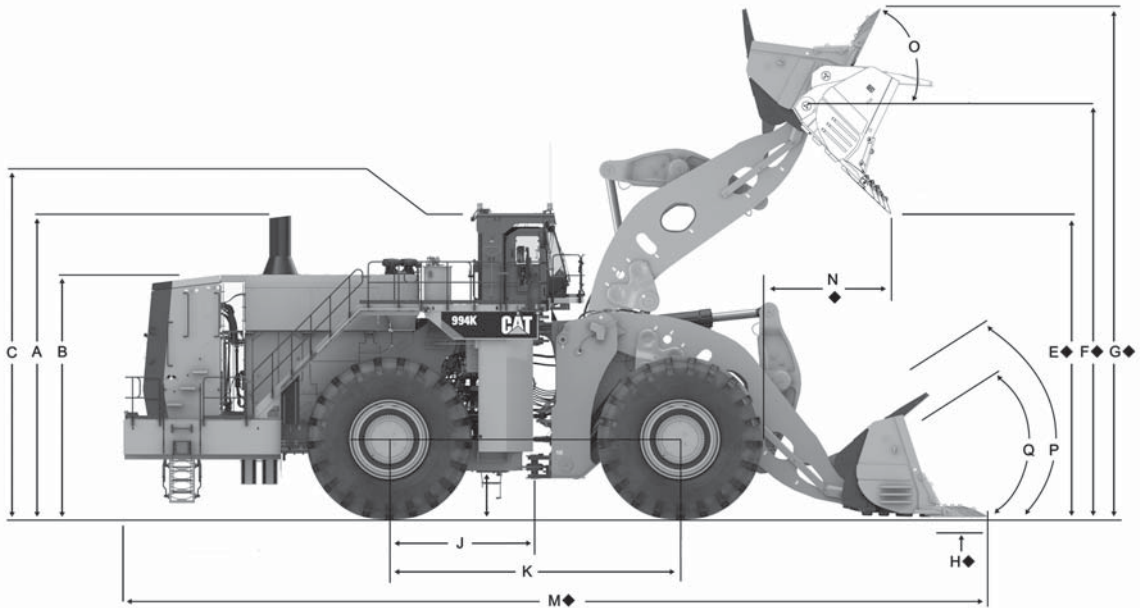

Dimensions shown represent standard machine with spade edge rock bucket and standard tires.

◆ Varies with Bucket Size and/or Bucket Configuration — Refer to Performance Data

MODEL	994K Standard Lift 6420 mm (21.1') Spade Edge Bucket with Teeth & Segments		994K Standard Lift 6420 mm (21.1') Spade Edge Bucket with Teeth & Segments		994K Standard Lift 6420 mm (21.1') Spade Edge Bucket with Teeth & Segments	
	21.4 m ³	28 yd ³	22.9 m ³	30 yd ³	24.5 m ³	32 yd ³
A Height to top of stack	7.1 m	23.2'	7.1 m	23.2'	7.1 m	23.2'
B Height to top of engine compartment	5.7 m	18.6'	5.7 m	18.6'	5.7 m	18.6'
C Height to top of ROPS	7.1 m	23.4'	7.1 m	23.4'	7.1 m	23.4'
D Hinge pin height at carry position	1262 mm	49.7"	1262 mm	49.7"	1262 mm	49.7"
◆ E Dump clearance at full lift and 45° discharge angle	6.24 m	20.5'	6.17 m	20.2'	6.10 m	20.0'
◆ F Hinge pin height at full lift	8.8 m	28.8'	8.8 m	28.8'	8.8 m	28.8'
◆ G Maximum overall height	11.69 m	38.3'	11.77 m	38.6'	11.87 m	39.0'
◆ H Maximum digging depth	232 mm	9.1"	232 mm	9.1"	232 mm	9.1"
J Machine center point to axle	3.4 m	11.2'	3.4 m	11.2'	3.4 m	11.2'
K Wheel base	6.8 m	22.3'	6.8 m	22.3'	6.8 m	22.3'
L Radius of tire	2.0 m	6.5'	2.0 m	6.5'	2.0 m	6.5'
◆ M Maximum overall length	17.76 m	58.3'	17.86 m	58.6'	17.96 m	58.9'
◆ N Reach at full lift	2.75 m	9.0'	2.82 m	9.3'	2.89 m	9.5'
O Maximum rollback at maximum lift	60°		60°		60°	
P Maximum rollback at carry height	48°		48°		48°	
Q Maximum rollback at ground	40°		40°		40°	
Ground clearance (std. tires)	898 mm	35.3"	898 mm	35.3"	898 mm	35.3"
Tread width (std. tires)	4.3 m	14.1'	4.3 m	14.1'	4.3 m	14.1'
Width over tires (std. tires)	5.8 m	18.0'	5.8 m	18.0'	5.8 m	18.0'
Tires used for measurements	BS 58/85-57 L-4		BS 58/85-57 L-4		BS 58/85-57 L-4	

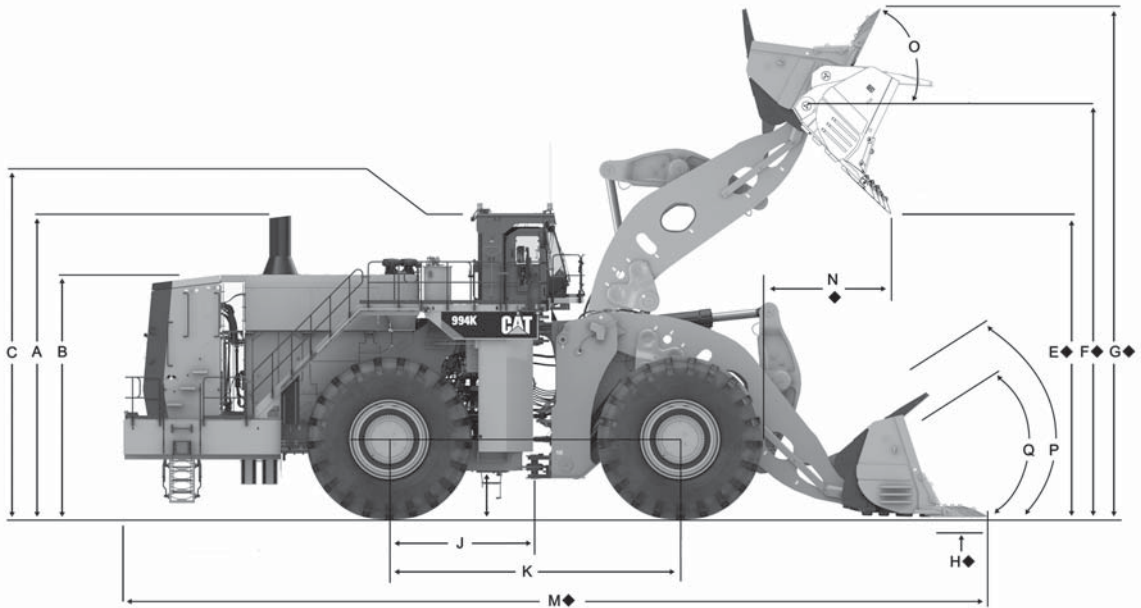

Dimensions shown represent standard machine with spade edge rock bucket and standard tires.

◆ Varies with Bucket Size and/or Bucket Configuration — Refer to Performance Data

MODEL	994K High Lift 6420 mm (21.1') Spade Edge Bucket with Teeth & Segments		994K High Lift 6420 mm (21.1') Spade Edge Bucket with Teeth & Segments		994K High Lift 6420 mm (21.1') Spade Edge Bucket with Teeth & Segments	
	19.1 m ³	25 yd ³	21.4 m ³	28 yd ³	22.9 m ³	30 yd ³
A Height to top of stack	7.1 m	23.2'	7.1 m	23.2'	7.1 m	23.2'
B Height to top of engine compartment	5.7 m	18.6'	5.7 m	18.6'	5.7 m	18.6'
C Height to top of ROPS	7.1 m	23.4'	7.1 m	23.4'	7.1 m	23.4'
D Hinge pin height at carry position	1424 mm	56.1"	1424 mm	56.1"	1424 mm	56.1"
◆ E Dump clearance at full lift and 45° discharge angle	7.20 m	23.6'	7.10 m	23.3'	7.02 m	23.0'
◆ F Hinge pin height at full lift	8.8 m	28.8'	8.8 m	28.8'	8.8 m	28.8'
◆ G Maximum overall height	12.40 m	40.7'	12.55 m	41.2'	12.63 m	41.4'
◆ H Maximum digging depth	239 mm	9.4"	239 mm	9.4"	239 mm	9.4"
J Machine center point to axle	3.4 m	11.2'	3.4 m	11.2'	3.4 m	11.2'
K Wheel base	6.8 m	22.3'	6.8 m	22.3'	6.8 m	22.3'
L Radius of tire	2.0 m	6.5'	2.0 m	6.5'	2.0 m	6.5'
◆ M Maximum overall length	18.30 m	60.0'	18.45 m	60.5'	18.55 m	60.9'
◆ N Reach at full lift	2.58 m	8.5'	2.69 m	8.8'	2.76 m	9.0'
O Maximum rollback at maximum lift		60°		60°		60°
P Maximum rollback at carry height		54°		54°		54°
Q Maximum rollback at ground		45°		45°		45°
Ground clearance (std. tires)	898 mm	35.3"	898 mm	35.3"	898 mm	35.3"
Tread width (std. tires)	4.3 m	14.1'	4.3 m	14.1'	4.3 m	14.1'
Width over tires (std. tires)	5.8 m	18.0'	5.8 m	18.0'	5.8 m	18.0'
Tires used for measurements	BS 58/85-57 L-4		BS 58/85-57 L-4		BS 58/85-57 L-4	

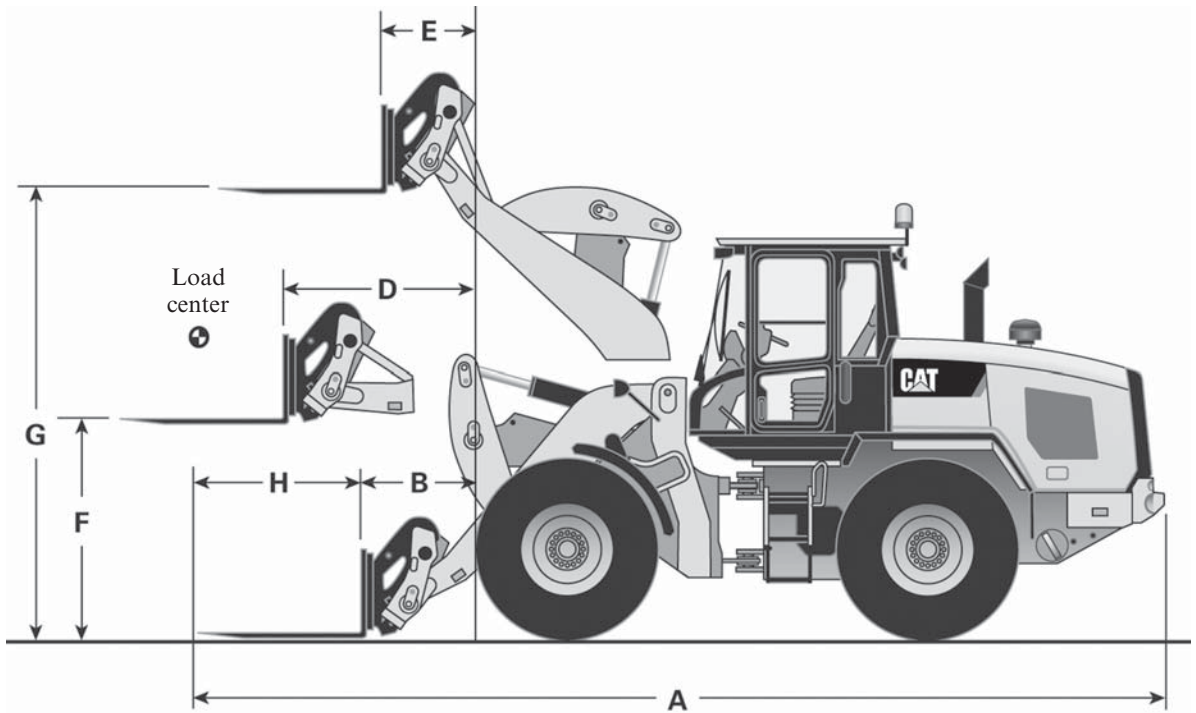

Dimensions listed are for a machine configured with Fusion coupler, standard counterweight, additional guarding, 80 kg (176 lb) operator, and Michelin 20.5 R25 (L-3) XHA2 tires.

MODEL	926M* Standard					
Rated operating load						
Per SAE J1197	2904 kg	6402 lb	2819 kg	6214 lb	2737 kg	6034 lb
Per CEN 474-3 rough terrain	3484 kg	7680 lb	3383 kg	7458 lb	3283 kg	7239 lb
Per CEN 474-3 firm level ground	4646 kg	10,242 lb	4510 kg	9942 lb	4378 kg	9651 lb
A Maximum overall length	7875 mm	25'10"	8025 mm	26'4"	8179 mm	26'10"
B Reach with forks at ground level	926 mm	3'0"	926 mm	3'0"	926 mm	3'0"
C Load center	610 mm	2'0"	685 mm	2'3"	762 mm	2'6"
D Reach with arms horizontal and forks level	1569 mm	5'2"	1569 mm	5'2"	1569 mm	5'2"
E Reach with forks at maximum height	767 mm	2'6"	767 mm	2'6"	767 mm	2'6"
F Arms horizontal and forks level	1792 mm	5'11"	1792 mm	5'11"	1792 mm	5'11"
G Ground to top of tine at maximum height	3693 mm	12'1"	3693 mm	12'1"	3693 mm	12'1"
H Fork tine length	1220 mm	4'0"	1370 mm	4'6"	1524 mm	5'0"
Tires	20.5 R25 (L-3) XHA2		20.5 R25 (L-3) XHA2		20.5 R25 (L-3) XHA2	

*Meets Tier 4 Final/Stage IV/Japan 2014 (Tier 4 Final) emission standards.

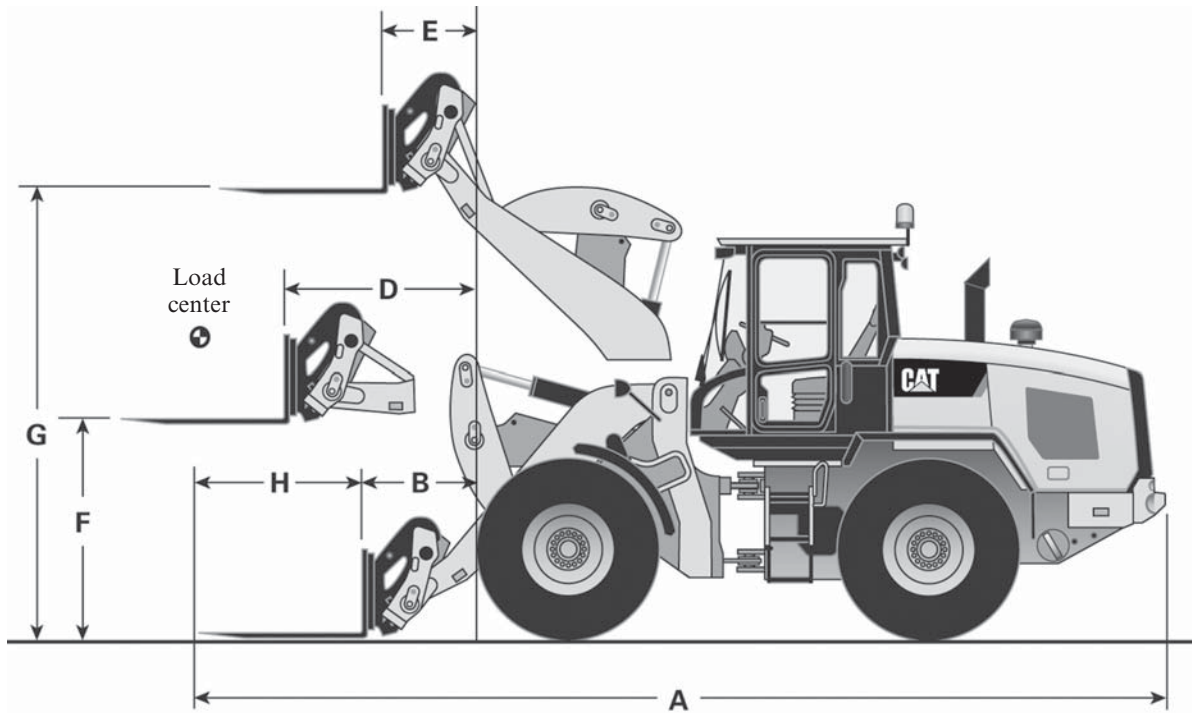

Dimensions listed are for a machine configured with Fusion coupler, standard counterweight, additional guarding, 80 kg (176 lb) operator, and Michelin 20.5 R25 (L-3) XHA2 tires.

MODEL	926M* High Lift					
Rated operating load						
Per SAE J1197	2317 kg	5108 lb	2256 kg	4973 lb	2196 kg	4841 lb
Per CEN 474-3 rough terrain	2780 kg	6128 lb	2707 kg	5967 lb	2635 kg	5809 lb
Per CEN 474-3 firm level ground	3706 kg	8170 lb	3610 kg	7958 lb	3514 kg	7747 lb
A Maximum overall length	8528 mm	28'0"	8678 mm	28'6"	8832 mm	29'0"
B Reach with forks at ground level	1578 mm	5'2"	1578 mm	5'2"	1578 mm	5'2"
C Load center	610 mm	2'0"	685 mm	2'3"	762 mm	2'6"
D Reach with arms horizontal and forks level	2092 mm	6'10"	2092 mm	6'10"	2092 mm	6'10"
E Reach with forks at maximum height	1004 mm	3'4"	1004 mm	3'4"	1004 mm	3'4"
F Arms horizontal and forks level	1792 mm	5'11"	1792 mm	5'11"	1792 mm	5'11"
G Ground to top of tine at maximum height	4186 mm	13'9"	4186 mm	13'9"	4186 mm	13'9"
H Fork tine length	1220 mm	4'0"	1370 mm	4'6"	1524 mm	5'0"
Tires	20.5 R25 (L-3) XHA2		20.5 R25 (L-3) XHA2		20.5 R25 (L-3) XHA2	

*Meets Tier 4 Final/Stage IV/Japan 2014 (Tier 4 Final) emission standards.

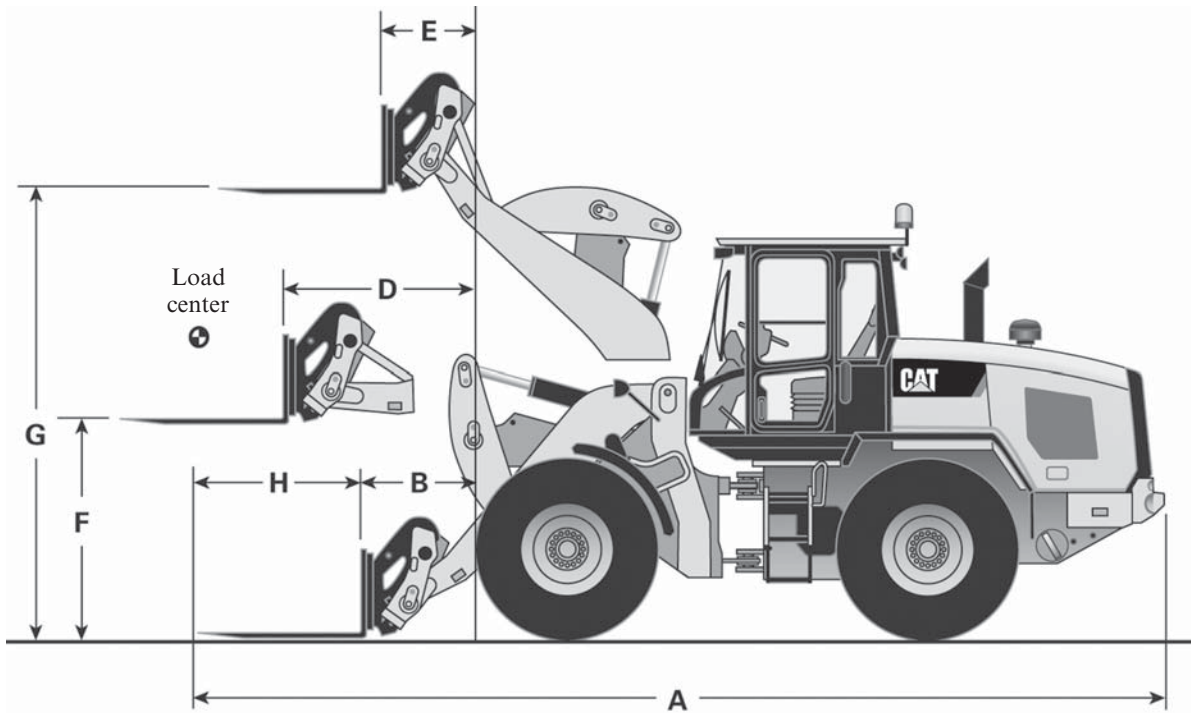

Dimensions listed are for a machine configured with Fusion coupler, heavy counterweight, additional guarding, 80 kg (176 lb) operator, and Michelin 20.5 R25 (L-3) XHA2 tires.

MODEL	930M* Standard					
Rated operating load						
Per SAE J1197	3289 kg	7250 lb	3195 kg	7043 lb	3103 kg	6840 lb
Per CEN 474-3 rough terrain	3946 kg	8699 lb	3833 kg	8450 lb	3723 kg	8207 lb
Per CEN 474-3 firm level ground	5262 kg	11,600 lb	5111 kg	11,267 lb	4964 kg	10,943 lb
A Maximum overall length	7882 mm	25'10"	8032 mm	26'4"	8186 mm	26'10"
B Reach with forks at ground level	926 mm	3'0"	926 mm	3'0"	926 mm	3'0"
C Load center	610 mm	2'0"	685 mm	2'3"	762 mm	2'6"
D Reach with arms horizontal and forks level	1569 mm	5'2"	1569 mm	5'2"	1569 mm	5'2"
E Reach with forks at maximum height	767 mm	2'6"	767 mm	2'6"	767 mm	2'6"
F Arms horizontal and forks level	1792 mm	5'11"	1792 mm	5'11"	1792 mm	5'11"
G Ground to top of tine at maximum height	3693 mm	12'1"	3693 mm	12'1"	3693 mm	12'1"
H Fork tine length	1220 mm	4'0"	1370 mm	4'6"	1524 mm	5'0"
Tires	20.5 R25 (L-3) XHA2		20.5 R25 (L-3) XHA2		20.5 R25 (L-3) XHA2	

*Meets Tier 4 Final/Stage IV/Japan 2014 (Tier 4 Final) emission standards.

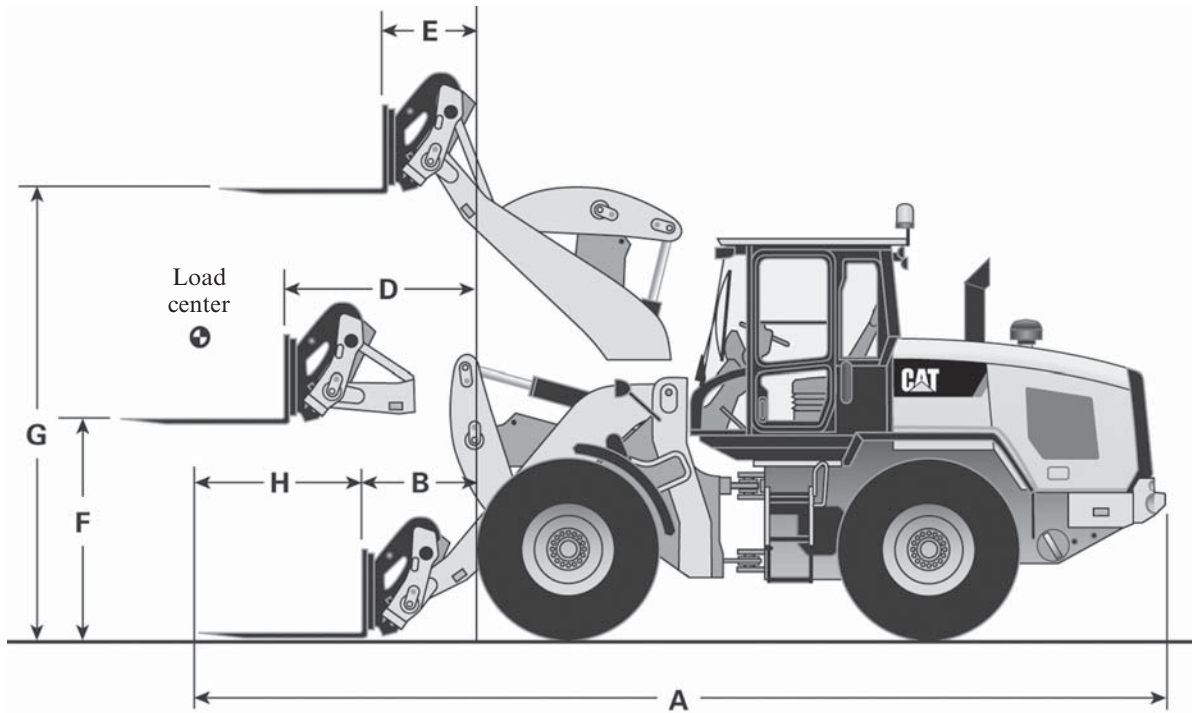

Dimensions listed are for a machine configured with Fusion coupler, heavy counterweight, additional guarding, 80 kg (176 lb) operator, and Michelin 20.5 R25 (L-3) XHA2 tires.

MODEL	930M* High Lift					
Rated operating load						
Per SAE J1197	2508 kg	5529 lb	2445 kg	5390 lb	2383 kg	5254 lb
Per CEN 474-3 rough terrain	3009 kg	6634 lb	2933 kg	6466 lb	2859 kg	6303 lb
Per CEN 474-3 firm level ground	4012 kg	8845 lb	3911 kg	8622 lb	3812 kg	8404 lb
A Maximum overall length	8689 mm	28'6"	8839 mm	29'0"	8993 mm	29'6"
B Reach with forks at ground level	1732 mm	5'8"	1732 mm	5'8"	1732 mm	5'8"
C Load center	610 mm	2'0"	685 mm	2'3"	762 mm	2'6"
D Reach with arms horizontal and forks level	2222 mm	7'3"	2222 mm	7'3"	2222 mm	7'3"
E Reach with forks at maximum height	1087 mm	3'7"	1087 mm	3'7"	1087 mm	3'7"
F Arms horizontal and forks level	1792 mm	5'11"	1792 mm	5'11"	1792 mm	5'11"
G Ground to top of tine at maximum height	4286 mm	14'1"	4286 mm	14'1"	4286 mm	14'1"
H Fork tine length	1220 mm	4'0"	1370 mm	4'6"	1554 mm	5'1"
Tires	20.5 R25 (L-3) XHA2		20.5 R25 (L-3) XHA2		20.5 R25 (L-3) XHA2	

*Meets Tier 4 Final/Stage IV/Japan 2014 (Tier 4 Final) emission standards.

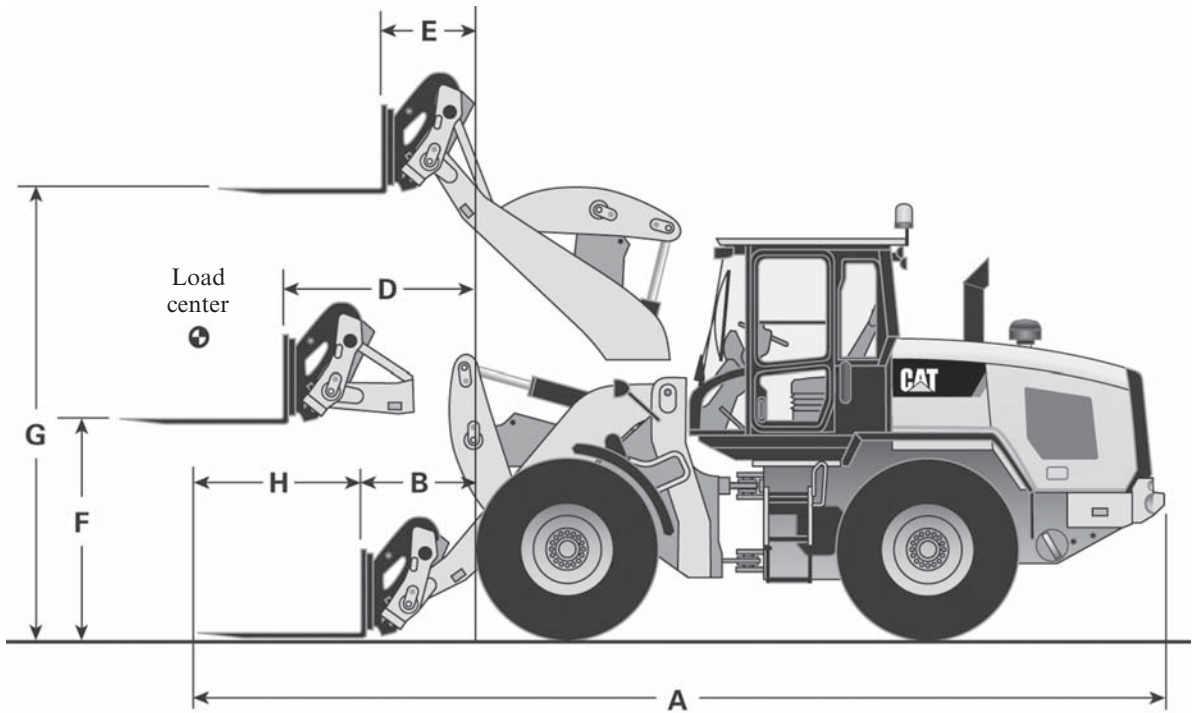

Dimensions listed are for a machine configured with Fusion coupler, heavy counterweight, additional guarding, 80 kg (176 lb) operator, and Michelin 20.5 R25 (L-3) XHA2 tires.

MODEL	938M*					
	Standard					
Rated operating load						
Per SAE J1197	3955 kg	8719 lb	3846 kg	8479 lb	3739 kg	8243 lb
Per CEN 474-3 rough terrain	4745 kg	10,461 lb	4615 kg	10,174 lb	4487 kg	9892 lb
Per CEN 474-3 firm level ground	6327 kg	13,949 lb	6154 kg	13,567 lb	5982 kg	13,188 lb
A Maximum overall length	7942 mm	26'1"	8092 mm	26'7"	8246 mm	27'1"
B Reach with forks at ground level	961 mm	3'2"	961 mm	3'2"	961 mm	3'2"
C Load center	610 mm	2'0"	685 mm	2'3"	762 mm	2'6"
D Reach with arms horizontal and forks level	1617 mm	5'4"	1617 mm	5'4"	1617 mm	5'4"
E Reach with forks at maximum height	814 mm	2'8"	814 mm	2'8"	814 mm	2'8"
F Arms horizontal and forks level	1830 mm	6'0"	1830 mm	6'0"	1830 mm	6'0"
G Ground to top of tine at maximum height	3758 mm	12'4"	3758 mm	12'4"	3758 mm	12'4"
H Fork tine length	1220 mm	4'0"	1370 mm	4'6"	1554 mm	5'1"
Tires	20.5 R25 (L-3) XHA2		20.5 R25 (L-3) XHA2		20.5 R25 (L-3) XHA2	

*Meets Tier 4 Final/Stage IV/Japan 2014 (Tier 4 Final) emission standards.

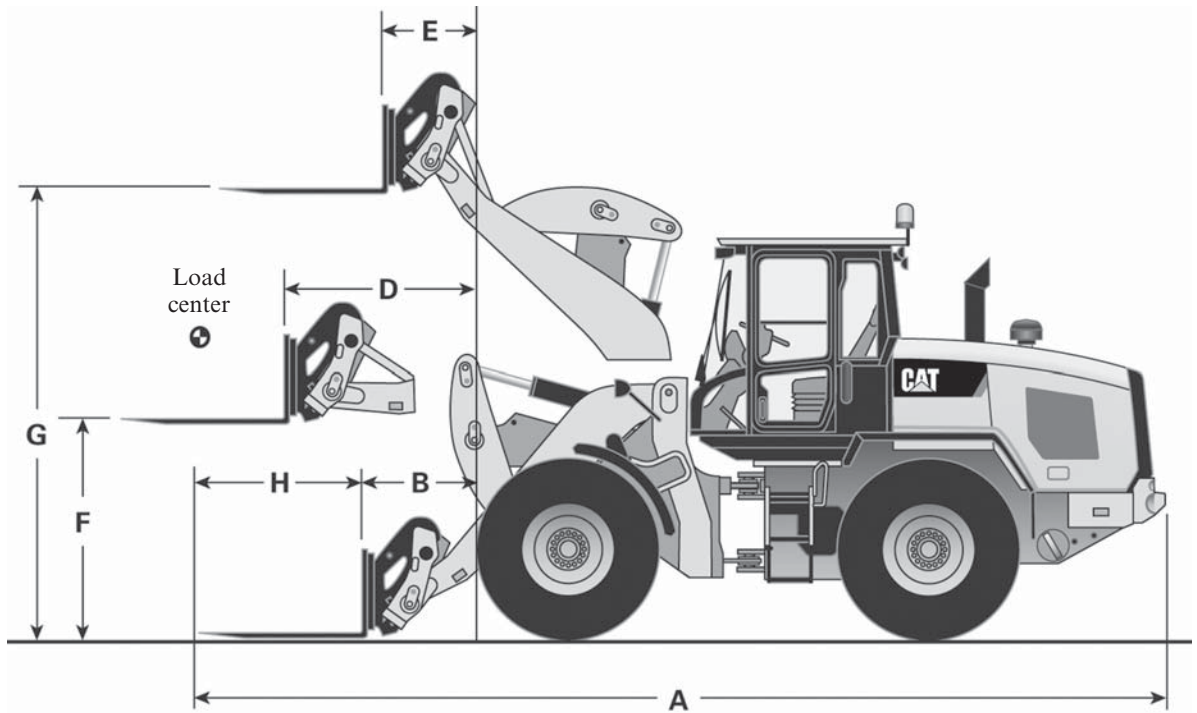

Dimensions listed are for a machine configured with Fusion coupler, heavy counterweight, additional guarding, 80 kg (176 lb) operator, and Michelin 20.5 R25 (L-3) XHA2 tires.

MODEL	938M* High Lift					
Rated operating load						
Per SAE J1197	2943 kg	6488 lb	2871 kg	6329 lb	2800 kg	6173 lb
Per CEN 474-3 rough terrain	3531 kg	7785 lb	3445 kg	7595 lb	3360 kg	7408 lb
Per CEN 474-3 firm level ground	4708 kg	10,379 lb	4594 kg	10,128 lb	4480 kg	9877 lb
A Maximum overall length	8695 mm	28'6"	8845 mm	29'0"	8999 mm	29'6"
B Reach with forks at ground level	1714 mm	5'7"	1714 mm	5'7"	1714 mm	5'7"
C Load center	610 mm	2'0"	685 mm	2'3"	762 mm	2'6"
D Reach with arms horizontal and forks level	2224 mm	7'4"	2224 mm	7'4"	2224 mm	7'4"
E Reach with forks at maximum height	1081 mm	3'7"	1081 mm	3'7"	1081 mm	3'7"
F Arms horizontal and forks level	1830 mm	6'0"	1830 mm	6'0"	1830 mm	6'0"
G Ground to top of tine at maximum height	4339 mm	14'3"	4339 mm	14'3"	4339 mm	14'3"
H Fork tine length	1220 mm	4'0"	1370 mm	4'6"	1554 mm	5'1"
Tires	20.5 R25 (L-3) XHA2		20.5 R25 (L-3) XHA2		20.5 R25 (L-3) XHA2	

*Meets Tier 4 Final/Stage IV/Japan 2014 (Tier 4 Final) emission standards.

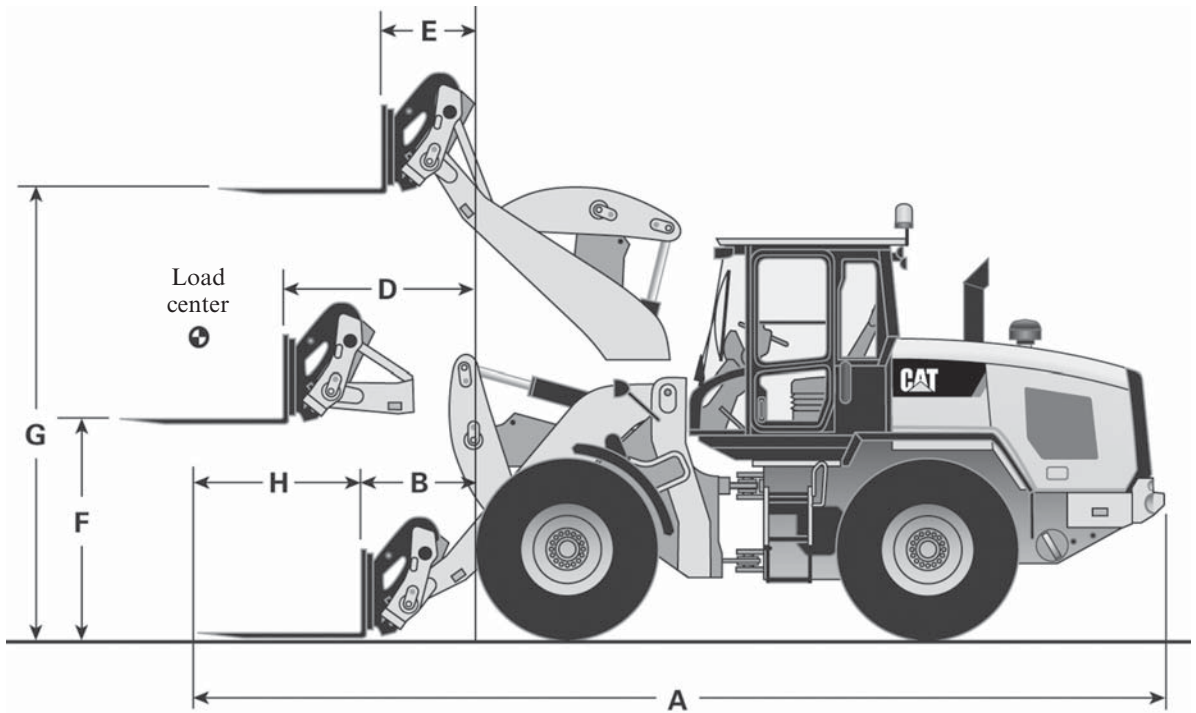

MODEL	924K Standard		930K Standard		938K Standard	
Rated operating load						
Per SAE J1197	2835 kg	6247 lb	3144 kg	6929 lb	3798 kg	8373 lb
Per CEN 474-3 rough terrain	3402 kg	7497 lb	3772 kg	8313 lb	4558 kg	10,049 lb
Per CEN 474-3 firm level ground	4536 kg	9996 lb	5030 kg	11,086 lb	6077 kg	13,397 lb
A Maximum overall length	7840 mm	25'8"	7882 mm	25'10"	7942 mm	26'0"
B Reach with forks at ground level	891 mm	2'11"	926 mm	3'0"	961 mm	3'1"
C Load center	610 mm	2'0"	610 mm	2'0"	610 mm	2'0"
D Reach with arms horizontal and forks level	1522 mm	4'11"	1569 mm	5'1"	1617 mm	5'3"
E Reach with fork at maximum height	724 mm	2'4"	767 mm	2'6"	814 mm	2'8"
F Arms horizontal and forks level	1761 mm	5'9"	1792 mm	5'10"	1830 mm	6'0"
G Ground to top of tine at maximum height	3639 mm	11'11"	3693 mm	12'1"	3758 mm	12'3"
H Fork tine length	1220 mm	4'0"	1220 mm	4'0"	1220 mm	4'0"
Tires	Michelin 20.5 R25 (L-3) XHA2		Michelin 20.5 R25 (L-3) XHA2		Michelin 20.5 R25 (L-3) XHA2	

NOTE: Fusion Pallet Forks

Wheel Loaders Integrated Toolcarriers

Machine Dimensions ● with Fusion Pallet Forks

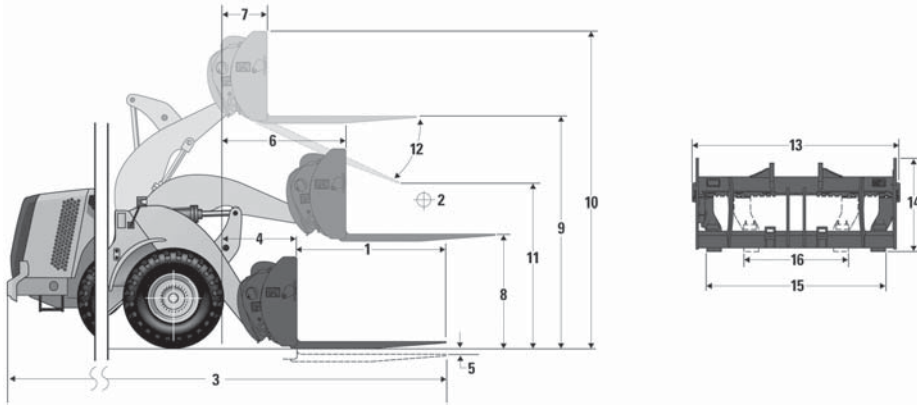

MODEL

950M

1 Fork tine length	1524 mm	60"	1829 mm	72"	2134 mm	84"	2438 mm	96"
2 Load center	762 mm	30"	915 mm	36"	1067 mm	42"	1219 mm	48"
Tipping load — forks level straight	9190 kg	20,255 lb	8724 kg	19,228 lb	8291 kg	18,273 lb	7890 kg	17,389 lb
Tipping load — forks level articulated	7924 kg	17,465 lb	7513 kg	16,560 lb	7131 kg	15,716 lb	6776 kg	14,934 lb
Rated load (SAE J1197)†	3962 kg	8733 lb	3757 kg	8280 lb	3565 kg	7858 lb	3388 kg	7467 lb
Rated load (CEN EN 474-3 rough terrain)‡	4755 kg	10,479 lb	4508 kg	9936 lb	4278 kg	9430 lb	4066 kg	8961 lb
Rated load (CEN EN 474-3 firm and level ground)‡	6340 kg	13,972 lb	6011 kg	13,248 lb	5705 kg	12,573 lb	5378 kg	11,854 lb
3 Maximum overall length	8820 mm	347.3"	9125 mm	359.3"	9430 mm	371.3"	9734 mm	383.2"
4 Reach with forks at ground level	1198 mm	47.2"	1198 mm	47.2"	1198 mm	47.2"	1198 mm	47.2"
5 Ground to top of tine at minimum height and fork level	23 mm	0.9"	23 mm	0.9"	23 mm	0.9"	23 mm	0.9"
6 Reach with arms horizontal and forks level	1738 mm	68.4"	1738 mm	68.4"	1738 mm	68.4"	1738 mm	68.4"
7 Reach with fork at maximum height	1023 mm	40.3"	1023 mm	40.3"	1023 mm	40.3"	1023 mm	40.3"
8 Ground to top of tine with arms horizontal and fork level	1889 mm	74.4"	1889 mm	74.4"	1889 mm	74.4"	1889 mm	74.4"
9 Ground to top of tine at maximum height and fork level	3824 mm	150.6"	3824 mm	150.6"	3824 mm	150.6"	3824 mm	150.6"
10 Overall height of fork at full lift (top of carriage to ground)	4865 mm	191.5"	4865 mm	191.5"	4865 mm	191.5"	4865 mm	191.5"
11 Clearance at full lift and maximum dump	2284 mm	89.9"	2041 mm	80.4"	1798 mm	70.8"	1556 mm	61.3"
12 Maximum discharge angle from horizontal		53°		53°		53°		53°
13 Carriage width	2528 mm	99.5"	2528 mm	99.5"	2528 mm	99.5"	2528 mm	99.5"
14 Carriage height	1130 mm	44.5"	1130 mm	44.5"	1130 mm	44.5"	1130 mm	44.5"
15 Outside tine width (maximum spread)	2178 mm	85.7"	2178 mm	85.7"	2178 mm	85.7"	2178 mm	85.7"
16 Outside tine width (minimum spread)	576 mm	22.7"	576 mm	22.7"	576 mm	22.7"	576 mm	22.7"
Tine width (single tine)	180 mm	7.1"	180 mm	7.1"	180 mm	7.1"	180 mm	7.1"
Tine thickness	90 mm	3.5"	90 mm	3.5"	90 mm	3.5"	90 mm	3.5"
Tine capacity	17 800 kg	39,231 lb	14 800 kg	32,619 lb	12 700 kg	27,991 lb	11 300 kg	24,905 lb
Operating weight	19 277 kg	42,487 lb	19 339 kg	42,624 lb	19 402 kg	42,763 lb	19 464 kg	42,899 lb

Based on 2438 mm (96") carriage, Fusion coupler and Fusion pallet fork.

Static tipping loads and operating weight are based on the following loader configuration: L3 Michelin XHA tires, air conditioning, ride control, power train guard, full fluids, fuel tank, coolant, lubricants, and operator.

Specifications and ratings conform to the following standards: SAE* J1197, SAE J732, CEN** EN 474-3.

The rated operating load for a loader equipped with a pallet fork is determined by:

- SAE J1197: 50% of full turn static tipping load or hydraulic limit.
- CEN EN 474-3: 60% of full turn static tipping load on rough terrain or hydraulic limit.
- CEN EN 474-3: 80% of full turn static tipping load on firm and level ground or hydraulic limit.

*SAE — Society of Automotive Engineers

**CEN — European Committee for Standardization

†Rated load is determined by considering % of machine stability, hydraulic lift capacity, and hydraulic tilt capacity. Please contact your dealer to properly select the machine configuration for handling target payloads in your specific machine application.

Machine and work tool availability varies by region. Contact your local Cat dealer for product availability.

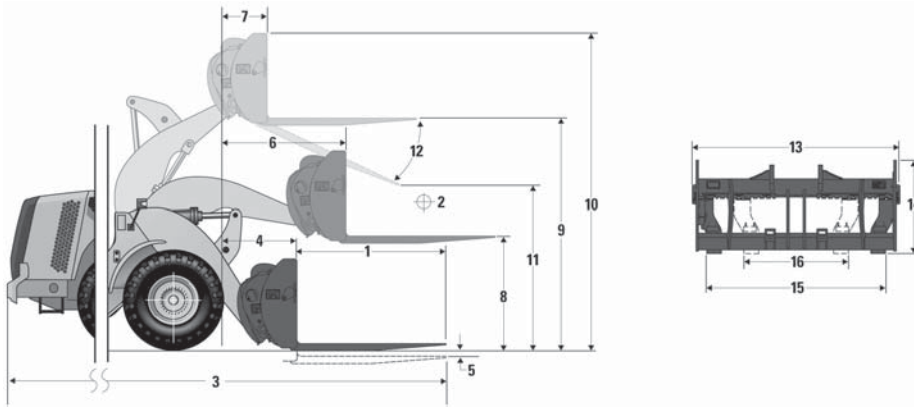

MODEL

962M

1 Fork tine length	1524 mm	60"	1829 mm	72"	2134 mm	84"	2438 mm	96"
2 Load center	762 mm	30"	915 mm	36"	1067 mm	42"	1219 mm	48"
Tipping load — forks level straight	10 165 kg	22,403 lb	9669 kg	21,310 lb	9207 kg	20,293 lb	8780 kg	19,350 lb
Tipping load — forks level articulated	8716 kg	19,211 lb	8282 kg	18,253 lb	7877 kg	17,361 lb	7501 kg	16,532 lb
Rated load (SAE J1197)†	4358 kg	9605 lb	4141 kg	9127 lb	3938 kg	8680 lb	3751 kg	8266 lb
Rated load (CEN EN 474-3 rough terrain)‡	5230 kg	11,527 lb	4969 kg	10,952 lb	4726 kg	10,416 lb	4501 kg	9919 lb
Rated load (CEN EN 474-3 firm and level ground)‡	6973 kg	15,369 lb	6626 kg	14,603 lb	6302 kg	13,889 lb	6001 kg	13,226 lb
3 Maximum overall length	9144 mm	360.0"	9449 mm	372.0"	9754 mm	384.0"	10 058 mm	396.0"
4 Reach with forks at ground level	1317 mm	51.8"	1317 mm	51.8"	1317 mm	51.8"	1317 mm	51.8"
5 Ground to top of tine at minimum height and fork level	24 mm	1.0"	24 mm	1.0"	24 mm	1.0"	24 mm	1.0"
6 Reach with arms horizontal and forks level	1836 mm	72.3"	1836 mm	72.3"	1836 mm	72.3"	1836 mm	72.3"
7 Reach with fork at maximum height	957 mm	37.7"	957 mm	37.7"	957 mm	37.7"	957 mm	37.7"
8 Ground to top of tine with arms horizontal and fork level	1889 mm	74.4"	1889 mm	74.4"	1889 mm	74.4"	1889 mm	74.4"
9 Ground to top of tine at maximum height and fork level	4041 mm	159.1"	4041 mm	159.1"	4041 mm	159.1"	4041 mm	159.1"
10 Overall height of fork at full lift (top of carriage to ground)	5081 mm	200.0"	5081 mm	200.0"	5081 mm	200.0"	5081 mm	200.0"
11 Clearance at full lift and maximum dump	2515 mm	99.0"	2274 mm	89.5"	2034 mm	80.1"	1794 mm	70.6"
12 Maximum discharge angle from horizontal		52°		52°		52°		52°
13 Carriage width	2528 mm	99.5"	2528 mm	99.5"	2528 mm	99.5"	2528 mm	99.5"
14 Carriage height	1130 mm	44.5"	1130 mm	44.5"	1130 mm	44.5"	1130 mm	44.5"
15 Outside tine width (maximum spread)	2178 mm	85.7"	2178 mm	85.7"	2178 mm	85.7"	2178 mm	85.7"
16 Outside tine width (minimum spread)	576 mm	22.7"	576 mm	22.7"	576 mm	22.7"	576 mm	22.7"
Tine width (single tine)	180 mm	7.1"	180 mm	7.1"	180 mm	7.1"	180 mm	7.1"
Tine thickness	90 mm	3.5"	90 mm	3.5"	90 mm	3.5"	90 mm	3.5"
Tine capacity	17 800 kg	39,231 lb	14 800 kg	32,619 lb	12 700 kg	27,991 lb	11 300 kg	24,905 lb
Operating weight	20 221 kg	44,566 lb	20 283 kg	44,703 lb	20 346 kg	44,842 lb	20 408 kg	44,979 lb

Based on 2438 mm (96") carriage, Fusion coupler and Fusion pallet fork.

Static tipping loads and operating weight are based on the following loader configuration: L3 Michelin XHA tires, air conditioning, ride control, power train guard, full fluids, fuel tank, coolant, lubricants, and operator.

Specifications and ratings conform to the following standards: SAE* J1197, SAE J732, CEN** EN 474-3.

The rated operating load for a loader equipped with a pallet fork is determined by:

- SAE J1197: 50% of full turn static tipping load or hydraulic limit.
- CEN EN 474-3: 60% of full turn static tipping load on rough terrain or hydraulic limit.
- CEN EN 474-3: 80% of full turn static tipping load on firm and level ground or hydraulic limit.

*SAE — Society of Automotive Engineers

**CEN — European Committee for Standardization

†Rated load is determined by considering % of machine stability, hydraulic lift capacity, and hydraulic tilt capacity. Please contact your dealer to properly select the machine configuration for handling target payloads in your specific machine application.

Machine and work tool availability varies by region. Contact your local Cat dealer for product availability.

Wheel Loaders Integrated Toolcarriers

Machine Dimensions ● with Fusion Pallet Forks

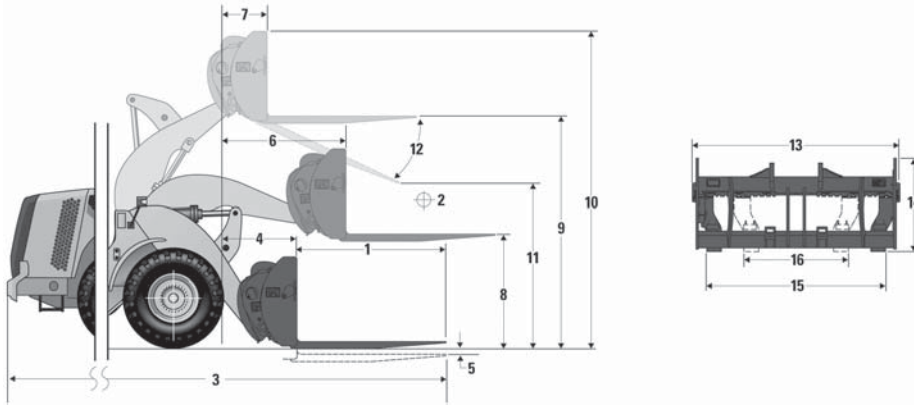

MODEL

966M

1 Fork tine length	1524 mm	60"	1829 mm	72"	2134 mm	84"	2438 mm	96"
2 Load center	762 mm	30"	915 mm	36"	1067 mm	42"	1219 mm	48"
Tipping load — forks level straight	11 924 kg	26,280 lb	11 345 kg	25,003 lb	10 807 kg	23,819 lb	10 310 kg	22,723 lb
Tipping load — forks level articulated	10 532 kg	23,214 lb	10 013 kg	22,069 lb	9531 kg	21,006 lb	9085 kg	20,023 lb
Rated load (SAE J1197)†	5266 kg	11,607 lb	5007 kg	11,035 lb	4766 kg	10,503 lb	4542 kg	10,011 lb
Rated load (CEN EN 474-3 rough terrain)†	6319 kg	13,928 lb	6008 kg	13,242 lb	5719 kg	12,604 lb	5451 kg	12,014 lb
Rated load (CEN EN 474-3 firm and level ground)†	8426 kg	18,571 lb	7807 kg	17,207 lb	6937 kg	15,290 lb	6222 kg	13,712 lb
3 Maximum overall length	9226 mm	363.2"	9531 mm	375.2"	9836 mm	387.2"	10 140 mm	399.2"
4 Reach with forks at ground level	1106 mm	43.5"	1106 mm	43.5"	1106 mm	43.5"	1106 mm	43.5"
5 Ground to top of tine at minimum height and fork level	-11 mm	-0.5"	-11 mm	-0.5"	-11 mm	-0.5"	-11 mm	-0.5"
6 Reach with arms horizontal and forks level	1704 mm	67.1"	1704 mm	67.1"	1704 mm	67.1"	1704 mm	67.1"
7 Reach with fork at maximum height	836 mm	32.9"	836 mm	32.9"	836 mm	32.9"	836 mm	32.9"
8 Ground to top of tine with arms horizontal and fork level	1955 mm	77.0"	1955 mm	77.0"	1955 mm	77.0"	1955 mm	77.0"
9 Ground to top of tine at maximum height and fork level	4039 mm	159.0"	4039 mm	159.0"	4039 mm	159.0"	4039 mm	159.0"
10 Overall height of fork at full lift (top of carriage to ground)	5079 mm	200.0"	5079 mm	200.0"	5079 mm	200.0"	5079 mm	200.0"
11 Clearance at full lift and maximum dump	2529 mm	99.6"	2292 mm	90.2"	2054 mm	80.9"	1818 mm	71.6"
12 Maximum discharge angle from horizontal		51°		51°		51°		51°
13 Carriage width	2528 mm	99.5"	2528 mm	99.5"	2528 mm	99.5"	2528 mm	99.5"
14 Carriage height	1130 mm	44.5"	1130 mm	44.5"	1130 mm	44.5"	1130 mm	44.5"
15 Outside tine width (maximum spread)	2178 mm	85.7"	2178 mm	85.7"	2178 mm	85.7"	2178 mm	85.7"
16 Outside tine width (minimum spread)	576 mm	22.7"	576 mm	22.7"	576 mm	22.7"	576 mm	22.7"
Tine width (single tine)	180 mm	7.1"	180 mm	7.1"	180 mm	7.1"	180 mm	7.1"
Tine thickness	90 mm	3.5"	90 mm	3.5"	90 mm	3.5"	90 mm	3.5"
Tine capacity	17 800 kg	39,231 lb	14 800 kg	32,619 lb	12 700 kg	27,991 lb	11 300 kg	24,905 lb
Operating weight	22 621 kg	49,857 lb	22 683 kg	49,994 lb	22 746 kg	50,133 lb	22 808 kg	50,270 lb

Based on 2438 mm (96") carriage, Fusion coupler and Fusion pallet fork.

Static tipping loads and operating weight are based on the following loader configuration: L3 Michelin XHA tires, air conditioning, ride control, power train guard, full fluids, fuel tank, coolant, lubricants, and operator.

Specifications and ratings conform to the following standards: SAE* J1197, SAE J732, CEN** EN 474-3.

The rated operating load for a loader equipped with a pallet fork is determined by:

- SAE J1197: 50% of full turn static tipping load or hydraulic limit.
- CEN EN 474-3: 60% of full turn static tipping load on rough terrain or hydraulic limit.
- CEN EN 474-3: 80% of full turn static tipping load on firm and level ground or hydraulic limit.

*SAE — Society of Automotive Engineers

**CEN — European Committee for Standardization

†Rated load is determined by considering % of machine stability, hydraulic lift capacity, and hydraulic tilt capacity. Please contact your dealer to properly select the machine configuration for handling target payloads in your specific machine application.

Machine and work tool availability varies by region. Contact your local Cat dealer for product availability.

Machine Dimensions ● with Fusion Pallet Forks

Wheel Loaders Integrated Toolcarriers

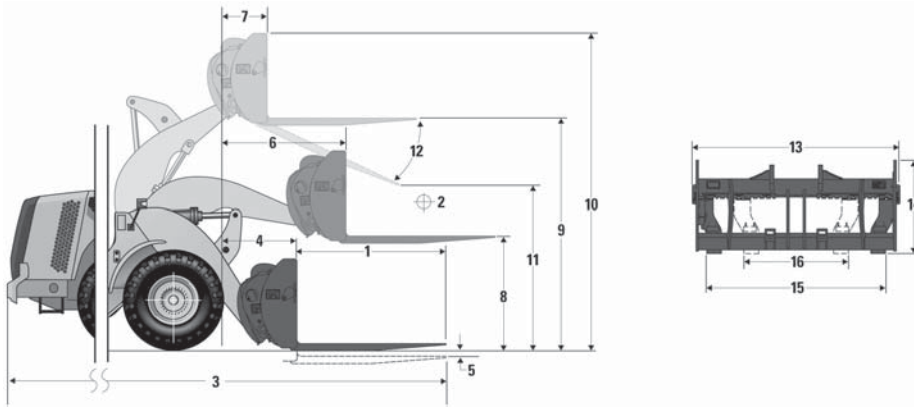

MODEL

972M

1 Fork tine length	1524 mm	60"	1829 mm	72"	2134 mm	84"	2438 mm	96"
2 Load center	762 mm	30"	915 mm	36"	1067 mm	42"	1219 mm	48"
Tipping load — forks level straight	13 644 kg	30,071 lb	13 012 kg	28,679 lb	12 425 kg	27,385 lb	11 881 kg	26,185 lb
Tipping load — forks level articulated	11 963 kg	26,366 lb	11 401 kg	25,129 lb	10 879 kg	23,977 lb	10 394 kg	22,909 lb
Rated load (SAE J1197)†	5981 kg	13,183 lb	5701 kg	12,564 lb	5439 kg	11,988 lb	5197 kg	11,454 lb
Rated load (CEN EN 474-3 rough terrain)‡	7178 kg	15,820 lb	6841 kg	15,077 lb	6527 kg	14,386 lb	6237 kg	13,745 lb
Rated load (CEN EN 474-3 firm and level ground)‡	9570 kg	21,093 lb	9121 kg	20,103 lb	8703 kg	19,182 lb	8315 kg	18,327 lb
3 Maximum overall length	9707 mm	382.2"	10 012 mm	394.2"	10 317 mm	406.2"	10 621 mm	418.1"
4 Reach with forks at ground level	1267 mm	49.9"	1267 mm	49.9"	1267 mm	49.9"	1267 mm	49.9"
5 Ground to top of tine at minimum height and fork level	10 mm	0.4"	10 mm	0.4"	10 mm	0.4"	10 mm	0.4"
6 Reach with arms horizontal and forks level	1834 mm	72.2"	1834 mm	72.2"	1834 mm	72.2"	1834 mm	72.2"
7 Reach with fork at maximum height	788 mm	31.0"	788 mm	31.0"	788 mm	31.0"	788 mm	31.0"
8 Ground to top of tine with arms horizontal and fork level	1956 mm	77.0"	1956 mm	77.0"	1956 mm	77.0"	1956 mm	77.0"
9 Ground to top of tine at maximum height and fork level	4262 mm	167.8"	4262 mm	167.8"	4262 mm	167.8"	4262 mm	167.8"
10 Overall height of fork at full lift (top of carriage to ground)	5302 mm	208.8"	5302 mm	208.8"	5302 mm	208.8"	5302 mm	208.8"
11 Clearance at full lift and maximum dump	2753 mm	108.4"	2516 mm	99.0"	2278 mm	89.7"	2042 mm	80.4"
12 Maximum discharge angle from horizontal		51°		51°		51°		51°
13 Carriage width	2528 mm	99.5"	2528 mm	99.5"	2528 mm	99.5"	2528 mm	99.5"
14 Carriage height	1130 mm	44.5"	1130 mm	44.5"	1130 mm	44.5"	1130 mm	44.5"
15 Outside tine width (maximum spread)	2178 mm	85.7"	2178 mm	85.7"	2178 mm	85.7"	2178 mm	85.7"
16 Outside tine width (minimum spread)	576 mm	22.7"	576 mm	22.7"	576 mm	22.7"	576 mm	22.7"
Tine width (single tine)	180 mm	7.1"	180 mm	7.1"	180 mm	7.1"	180 mm	7.1"
Tine thickness	90 mm	3.5"	90 mm	3.5"	90 mm	3.5"	90 mm	3.5"
Tine capacity	17 800 kg	39,231 lb	14 800 kg	32,619 lb	12 700 kg	27,991 lb	11 300 kg	24,905 lb
Operating weight	24 316 kg	53,592 lb	24 378 kg	53,729 lb	24 441 kg	53,868 lb	24 503 kg	54,004 lb

Based on 2438 mm (96") carriage, Fusion coupler and Fusion pallet fork.

Static tipping loads and operating weight are based on the following loader configuration: L3 Michelin XHA tires, air conditioning, ride control, power train guard, full fluids, fuel tank, coolant, lubricants, and operator.

Specifications and ratings conform to the following standards: SAE* J1197, SAE J732, CEN** EN 474-3.

The rated operating load for a loader equipped with a pallet fork is determined by:

- SAE J1197: 50% of full turn static tipping load or hydraulic limit.
- CEN EN 474-3: 60% of full turn static tipping load on rough terrain or hydraulic limit.
- CEN EN 474-3: 80% of full turn static tipping load on firm and level ground or hydraulic limit.

*SAE — Society of Automotive Engineers

**CEN — European Committee for Standardization

†Rated load is determined by considering % of machine stability, hydraulic lift capacity, and hydraulic tilt capacity. Please contact your dealer to properly select the machine configuration for handling target payloads in your specific machine application.

Machine and work tool availability varies by region. Contact your local Cat dealer for product availability.

Wheel Loaders Integrated Toolcarriers

Machine Dimensions ● with HPL Pallet Forks

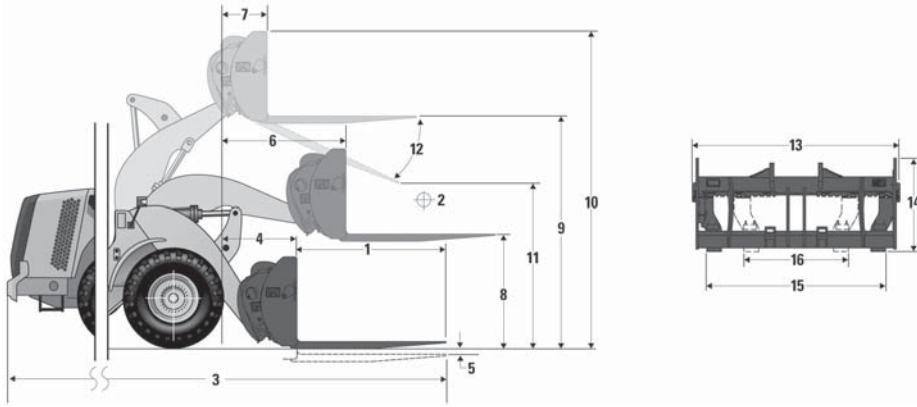

MODEL

980M

1 Fork tine length	1829 mm	72"	2134 mm	84"	2438 mm	96"
2 Load center	914 mm	36"	1067 mm	42"	1219 mm	48"
Tipping load — forks level straight	13 515 kg	29,788 lb	12 913 kg	28,460 lb	12 315 kg	27,142 lb
Tipping load — forks level articulated	11 655 kg	25,687 lb	11 123 kg	24,515 lb	10 591 kg	23,343 lb
Rated load (SAE J1197)†	5827 kg	12,844 lb	5562 kg	12,258 lb	5296 kg	11,671 lb
Rated load (CEN EN 474-3 rough terrain)†	6993 kg	15,412 lb	6674 kg	14,709 lb	6033 kg	13,296 lb
Rated load (CEN EN 474-3 firm and level ground)†	7479 kg	16,483 lb	6718 kg	14,807 lb	6033 kg	13,296 lb
3 Maximum overall length	10 412 mm	409.9"	10 717 mm	421.9"	11 022 mm	433.9"
4 Reach with forks at ground level	1385 mm	54.5"	1385 mm	54.5"	1385 mm	54.5"
5 Ground to top of tine at minimum height and fork level	-42 mm	-1.7"	-42 mm	-1.7"	-42 mm	-1.7"
6 Reach with arms horizontal and forks level	1991 mm	78.4"	1991 mm	78.4"	1991 mm	78.4"
7 Reach with fork at maximum height	1065 mm	41.9"	1065 mm	41.9"	1065 mm	41.9"
8 Ground to top of tine with arms horizontal and fork level	2067 mm	81.4"	2067 mm	81.4"	2067 mm	81.4"
9 Ground to top of tine at maximum height and fork level	4335 mm	170.7"	4335 mm	170.7"	4335 mm	170.7"
10 Overall height of fork at full lift (top of carriage to ground)	5827 mm	229.4"	5827 mm	229.4"	5827 mm	229.4"
11 Clearance at full lift and maximum dump	2324 mm	91.5"	2074 mm	81.7"	1825 mm	71.8"
12 Maximum discharge angle from horizontal		55°		55°		55°
13 Carriage width	2852 mm	112.3"	2852 mm	112.3"	2852 mm	112.3"
14 Carriage height	1581 mm	62.3"	1581 mm	62.3"	1581 mm	62.3"
15 Outside tine width (maximum spread)	2670 mm	105.1"	2670 mm	105.1"	2670 mm	105.1"
16 Outside tine width (minimum spread)	850 mm	33.5"	850 mm	33.5"	850 mm	33.5"
Tine width (single tine)	200 mm	7.9"	200 mm	7.9"	200 mm	7.9"
Tine thickness	90 mm	3.5"	90 mm	3.5"	90 mm	3.5"
Tine capacity	14 764 kg	32,540 lb	12 656 kg	27,894 lb	11 068 kg	24,394 lb
Operating weight	29 610 kg	65,260 lb	29 696 kg	65,450 lb	29 807 kg	65,694 lb

Static tipping loads and operating weight are based on the following loader configuration: L3 Michelin XHA tires, air conditioning, ride control, power train guard, full fluids, fuel tank, coolant, lubricants, and operator.

Specifications and ratings conform to the following standards: SAE* J1197, SAE J732, CEN** EN 474-3.

The rated operating load for a loader equipped with a pallet fork is determined by:

- SAE J1197: 50% of full turn static tipping load or hydraulic limit.
- CEN EN 474-3: 60% of full turn static tipping load on rough terrain or hydraulic limit.
- CEN EN 474-3: 80% of full turn static tipping load on firm and level ground or hydraulic limit.

*SAE — Society of Automotive Engineers

**CEN — European Committee for Standardization

†Rated load is determined by considering % of machine stability, hydraulic lift capacity, and hydraulic tilt capacity. Please contact your dealer to properly select the machine configuration for handling target payloads in your specific machine application.

Machine and work tool availability varies by region. Contact your local Cat dealer for product availability.

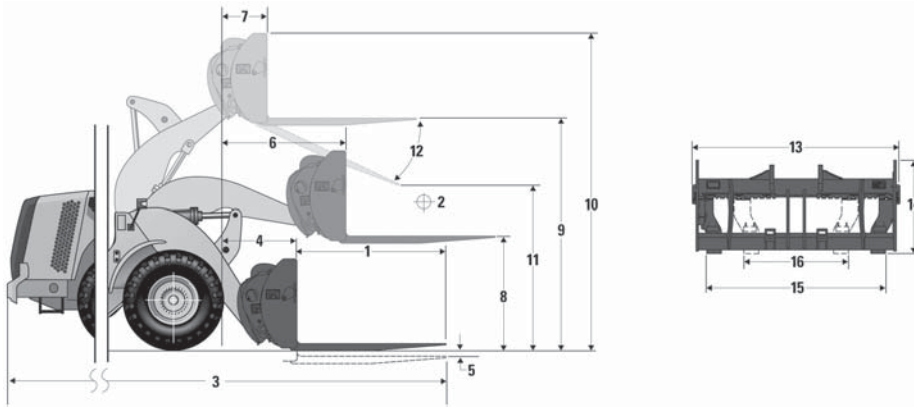

MODEL

950K

1 Fork tine length	1524 mm	60"	1829 mm	72"	2134 mm	84"	2438 mm	96"
2 Load center	762 mm	30"	915 mm	36"	1067 mm	42"	1219 mm	48"
Tipping load — forks level straight	9232 kg	20,347 lb	8763 kg	19,313 lb	8327 kg	18,353 lb	7924 kg	17,464 lb
Tipping load — forks level articulated	7985 kg	17,599 lb	7570 kg	16,685 lb	7185 kg	15,835 lb	6827 kg	15,047 lb
Rated load (SAE J1197)†	3993 kg	8800 lb	3785 kg	8343 lb	3592 kg	7917 lb	3414 kg	7523 lb
Rated load (CEN EN 474-3 rough terrain)†	4791 kg	10,559 lb	4542 kg	10,011 lb	4311 kg	9501 lb	4096 kg	9028 lb
Rated load (CEN EN 474-3 firm and level ground)†	6388 kg	14,079 lb	6056 kg	13,348 lb	5748 kg	12,668 lb	5424 kg	11,954 lb
3 Maximum overall length	8774 mm	345.4"	9079 mm	357.4"	9384 mm	369.4"	9688 mm	381.4"
4 Reach with forks at ground level	1189 mm	46.8"	1189 mm	46.8"	1189 mm	46.8"	1189 mm	46.8"
5 Ground to top of tine at minimum height and fork level	68 mm	2.7"	68 mm	2.7"	68 mm	2.7"	68 mm	2.7"
6 Reach with arms horizontal and forks level	1728 mm	68.0"	1728 mm	68.0"	1728 mm	68.0"	1728 mm	68.0"
7 Reach with fork at maximum height	1013 mm	39.9"	1013 mm	39.9"	1013 mm	39.9"	1013 mm	39.9"
8 Ground to top of tine with arms horizontal and fork level	1798 mm	70.8"	1798 mm	70.8"	1798 mm	70.8"	1798 mm	70.8"
9 Ground to top of tine at maximum height and fork level	3733 mm	147.0"	3733 mm	147.0"	3733 mm	147.0"	3733 mm	147.0"
10 Overall height of fork at full lift (top of carriage to ground)	4863 mm	191.5"	4863 mm	191.5"	4863 mm	191.5"	4863 mm	191.5"
11 Clearance at full lift and maximum dump	2438 mm	96.0"	2222 mm	87.5"	2006 mm	79.0"	1792 mm	70.5"
12 Maximum discharge angle from horizontal		45°		45°		45°		45°
13 Carriage width	2528 mm	99.5"	2528 mm	99.5"	2528 mm	99.5"	2528 mm	99.5"
14 Carriage height	1220 mm	48.0"	1220 mm	48.0"	1220 mm	48.0"	1220 mm	48.0"
15 Outside tine width (maximum spread)	2178 mm	85.7"	2178 mm	85.7"	2178 mm	85.7"	2178 mm	85.7"
16 Outside tine width (minimum spread)	576 mm	22.7"	576 mm	22.7"	576 mm	22.7"	576 mm	22.7"
Tine width (single tine)	180 mm	7.1"	180 mm	7.1"	180 mm	7.1"	180 mm	7.1"
Tine thickness	90 mm	3.5"	90 mm	3.5"	90 mm	3.5"	90 mm	3.5"
Operating weight	19 445 kg	42,857 lb	19 507 kg	42,994 lb	19 570 kg	43,133 lb	19 632 kg	43,269 lb

Based on 2438 mm (96") carriage, Fusion coupler and Fusion pallet fork.

Static tipping loads and operating weight are based on the following loader configuration: L3 Michelin XHA tires, air conditioning, ride control, power train guard, full fluids, fuel tank, coolant, lubricants, and operator. Static tipping loads conform to the international standard as defined in ISO* 14397-1 (Sept2007).

Specifications and ratings conform to the following standards: ISO 14397-1, SAE** J1197, SAE J732, CEN*** EN 474-3.

The rated operating load for a loader equipped with a pallet fork is determined by:

- SAE J1197: 50% of full turn static tipping load or hydraulic limit.
- CEN EN 474-3: 60% of full turn static tipping load on rough terrain or hydraulic limit.
- CEN EN 474-3: 80% of full turn static tipping load on firm and level ground or hydraulic limit.

*ISO — International Organization for Standardization

**SAE — Society of Automotive Engineers

***CEN — European Committee for Standardization

†Rated load is determined by considering % of machine stability, hydraulic lift capacity, and hydraulic tilt capacity. Please contact your dealer to properly select the machine configuration for handling target payloads in your specific machine application.

Machine and work tool availability varies by region. Contact your local Cat dealer for product availability.

Wheel Loaders Integrated Toolcarriers

Machine Dimensions ● with Fusion Pallet Forks

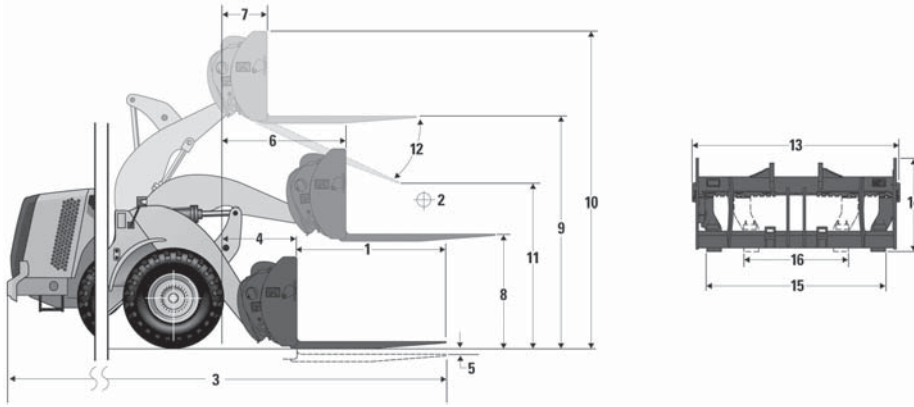

MODEL

962K

1 Fork tine length	1524 mm	60"	1829 mm	72"	2134 mm	84"	2438 mm	96"
2 Load center	762 mm	30"	915 mm	36"	1067 mm	42"	1219 mm	48"
Tipping load — forks level straight	10 192 kg	22,463 lb	9694 kg	21,366 lb	9231 kg	20,344 lb	8801 kg	19,398 lb
Tipping load — forks level articulated	8767 kg	19,322 lb	8329 kg	18,357 lb	7921 kg	17,458 lb	7543 kg	16,625 lb
Rated load (SAE J1197)†	4383 kg	9661 lb	4165 kg	9179 lb	3961 kg	8729 lb	3771 kg	8312 lb
Rated load (CEN EN 474-3 rough terrain)†	5260 kg	11,593 lb	4997 kg	11,014 lb	4753 kg	10,475 lb	4526 kg	9975 lb
Rated load (CEN EN 474-3 firm and level ground)†	7013 kg	15,457 lb	6663 kg	14,686 lb	6337 kg	13,967 lb	6034 kg	13,300 lb
3 Maximum overall length	9042 mm	356.0"	9347 mm	368.0"	9652 mm	380.0"	9956 mm	392.0"
4 Reach with forks at ground level	1307 mm	51.5"	1307 mm	51.5"	1307 mm	51.5"	1307 mm	51.5"
5 Ground to top of tine at minimum height and fork level	67 mm	2.6"	67 mm	2.6"	67 mm	2.6"	67 mm	2.6"
6 Reach with arms horizontal and forks level	1826 mm	71.9"	1826 mm	71.9"	1826 mm	71.9"	1826 mm	71.9"
7 Reach with fork at maximum height	947 mm	37.3"	947 mm	37.3"	947 mm	37.3"	947 mm	37.3"
8 Ground to top of tine with arms horizontal and fork level	1798 mm	70.8"	1798 mm	70.8"	1798 mm	70.8"	1798 mm	70.8"
9 Ground to top of tine at maximum height and fork level	3950 mm	155.5"	3950 mm	155.5"	3950 mm	155.5"	3950 mm	155.5"
10 Overall height of fork at full lift (top of carriage to ground)	5080 mm	200.0"	5080 mm	200.0"	5080 mm	200.0"	5080 mm	200.0"
11 Clearance at full lift and maximum dump	2655 mm	104.5"	2439 mm	96.0"	2223 mm	87.5"	2008 mm	79.1"
12 Maximum discharge angle from horizontal		45°		45°		45°		45°
13 Carriage width	2528 mm	99.5"	2528 mm	99.5"	2528 mm	99.5"	2528 mm	99.5"
14 Carriage height	1220 mm	48.0"	1220 mm	48.0"	1220 mm	48.0"	1220 mm	48.0"
15 Outside tine width (maximum spread)	2178 mm	85.7"	2178 mm	85.7"	2178 mm	85.7"	2178 mm	85.7"
16 Outside tine width (minimum spread)	576 mm	22.7"	576 mm	22.7"	576 mm	22.7"	576 mm	22.7"
Tine width (single tine)	180 mm	7.1"	180 mm	7.1"	180 mm	7.1"	180 mm	7.1"
Tine thickness	90 mm	3.5"	90 mm	3.5"	90 mm	3.5"	90 mm	3.5"
Operating weight	20 394 kg	44,948 lb	20 456 kg	45,084 lb	20 519 kg	45,223 lb	20 581 kg	45,360 lb

Based on 2438 mm (96") carriage, Fusion coupler and Fusion pallet fork.

Static tipping loads and operating weight are based on the following loader configuration: L3 Michelin XHA tires, air conditioning, ride control, power train guard, full fluids, fuel tank, coolant, lubricants, and operator. Static tipping loads conform to the international standard as defined in ISO* 14397-1 (Sept2007).

Specifications and ratings conform to the following standards: ISO 14397-1, SAE** J1197, SAE J732, CEN*** EN 474-3.

†Rated load is determined by considering % of machine stability, hydraulic lift capacity, and hydraulic tilt capacity. Please contact your dealer to properly select the machine configuration for handling target payloads in your specific machine application.

Machine and work tool availability varies by region. Contact your local Cat dealer for product availability.

The rated operating load for a loader equipped with a pallet fork is determined by:

- SAE J1197: 50% of full turn static tipping load or hydraulic limit.
- CEN EN 474-3: 60% of full turn static tipping load on rough terrain or hydraulic limit.
- CEN EN 474-3: 80% of full turn static tipping load on firm and level ground or hydraulic limit.

*ISO — International Organization for Standardization

**SAE — Society of Automotive Engineers

***CEN — European Committee for Standardization

Machine Dimensions ● with Fusion Pallet Forks

Wheel Loaders Integrated Toolcarriers

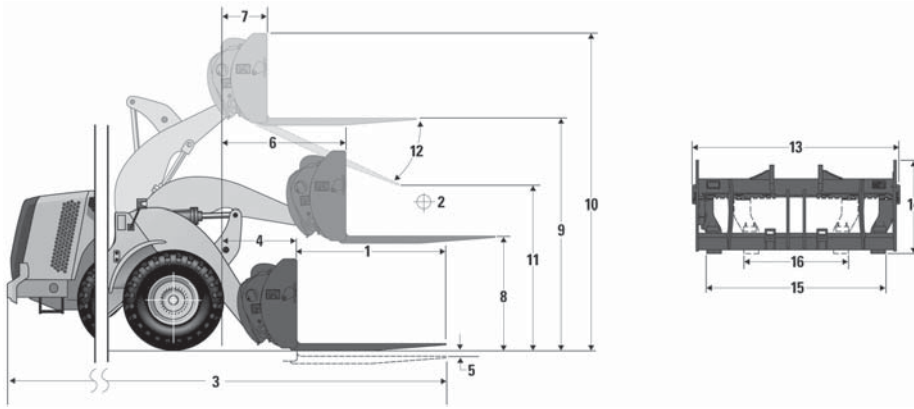

MODEL

966K

1 Fork tine length	1524 mm	60"	1829 mm	72"	2134 mm	84"	2438 mm	96"
2 Load center	762 mm	30"	915 mm	36"	1067 mm	42"	1219 mm	48"
Tipping load — forks level straight	12 045 kg	26,548 lb	11 464 kg	25,267 lb	10 925 kg	24,079 lb	10 426 kg	22,979 lb
Tipping load — forks level articulated	10 629 kg	23,427 lb	10 109 kg	22,280 lb	9625 kg	21,214 lb	9178 kg	20,228 lb
Rated load (SAE J1197)†	5315 kg	11,713 lb	5054 kg	11,140 lb	4813 kg	10,607 lb	4589 kg	10,114 lb
Rated load (CEN EN 474-3 rough terrain)†	6378 kg	14,506 lb	6065 kg	13,368 lb	5775 kg	12,729 lb	5507 kg	12,137 lb
Rated load (CEN EN 474-3 firm and level ground)†	8503 kg	18,741 lb	7806 kg	17,205 lb	6928 kg	15,269 lb	6207 kg	13,681 lb
3 Maximum overall length	9148 mm	360.2"	9453 mm	372.2"	9758 mm	384.2"	10 062 mm	396.2"
4 Reach with forks at ground level	1122 mm	44.2"	1122 mm	44.2"	1122 mm	44.2"	1122 mm	44.2"
5 Ground to top of tine at minimum height and fork level	97 mm	3.8"	97 mm	3.8"	97 mm	3.8"	97 mm	3.8"
6 Reach with arms horizontal and forks level	1723 mm	67.9"	1723 mm	67.9"	1723 mm	67.9"	1723 mm	67.9"
7 Reach with fork at maximum height	856 mm	33.7"	856 mm	33.7"	856 mm	33.7"	856 mm	33.7"
8 Ground to top of tine with arms horizontal and fork level	1870 mm	73.6"	1870 mm	73.6"	1870 mm	73.6"	1870 mm	73.6"
9 Ground to top of tine at maximum height and fork level	3953 mm	155.6"	3953 mm	155.6"	3953 mm	155.6"	3953 mm	155.6"
10 Overall height of fork at full lift (top of carriage to ground)	5083 mm	200.1"	5083 mm	200.1"	5083 mm	200.1"	5083 mm	200.1"
11 Clearance at full lift and maximum dump	2580 mm	101.6"	2349 mm	92.5"	2119 mm	83.4"	1889 mm	74.4"
12 Maximum discharge angle from horizontal		49°		49°		49°		49°
13 Carriage width	2528 mm	99.5"	2528 mm	99.5"	2528 mm	99.5"	2528 mm	99.5"
14 Carriage height	1220 mm	48.0"	1220 mm	48.0"	1220 mm	48.0"	1220 mm	48.0"
15 Outside tine width (maximum spread)	2178 mm	85.7"	2178 mm	85.7"	2178 mm	85.7"	2178 mm	85.7"
16 Outside tine width (minimum spread)	576 mm	22.7"	576 mm	22.7"	576 mm	22.7"	576 mm	22.7"
Tine width (single tine)	180 mm	7.1"	180 mm	7.1"	180 mm	7.1"	180 mm	7.1"
Tine thickness	90 mm	3.5"	90 mm	3.5"	90 mm	3.5"	90 mm	3.5"
Operating weight	23 588 kg	51,988 lb	23 650 kg	52,124 lb	23 713 kg	52,263 lb	23 775 kg	52,400 lb

Based on 2438 mm (96") carriage, Fusion coupler and Fusion pallet fork.

Static tipping loads and operating weight are based on the following loader configuration: L3 Michelin XHA tires, air conditioning, ride control, power train guard, full fluids, fuel tank, coolant, lubricants, and operator. Static tipping loads conform to the international standard as defined in ISO* 14397-1 (Sept2007).

Specifications and ratings conform to the following standards: ISO 14397-1, SAE** J1197, SAE J732, CEN*** EN 474-3.

The rated operating load for a loader equipped with a pallet fork is determined by:

- SAE J1197: 50% of full turn static tipping load or hydraulic limit.
- CEN EN 474-3: 60% of full turn static tipping load on rough terrain or hydraulic limit.
- CEN EN 474-3: 80% of full turn static tipping load on firm and level ground or hydraulic limit.

*ISO — International Organization for Standardization

**SAE — Society of Automotive Engineers

***CEN — European Committee for Standardization

†Rated load is determined by considering % of machine stability, hydraulic lift capacity, and hydraulic tilt capacity. Please contact your dealer to properly select the machine configuration for handling target payloads in your specific machine application.

Machine and work tool availability varies by region. Contact your local Cat dealer for product availability.

Wheel Loaders Integrated Toolcarriers

Machine Dimensions ● with Fusion Pallet Forks

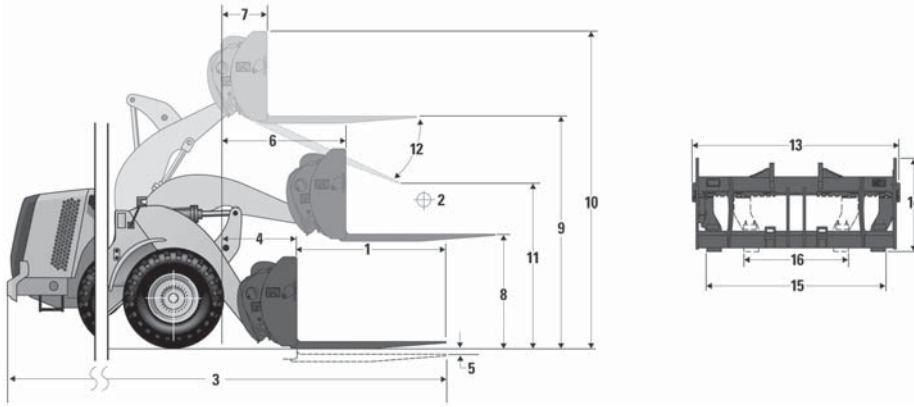

MODEL

972K

1 Fork tine length	1524 mm	60"	1829 mm	72"	2134 mm	84"	2438 mm	96"
2 Load center	762 mm	30"	915 mm	36"	1067 mm	42"	1219 mm	48"
Tipping load — forks level straight	13 924 kg	30,688 lb	13 285 kg	29,279 lb	12 690 kg	27,969 lb	12 139 kg	26,754 lb
Tipping load — forks level articulated	12 202 kg	26,894 lb	11 634 kg	25,642 lb	11 105 kg	24,476 lb	10 615 kg	23,395 lb
Rated load (SAE J1197)†	6101 kg	13,447 lb	5817 kg	12,821 lb	5553 kg	12,238 lb	5307 kg	11,697 lb
Rated load (CEN EN 474-3 rough terrain)†	7321 kg	16,136 lb	6981 kg	15,385 lb	6663 kg	14,686 lb	6369 kg	14,037 lb
Rated load (CEN EN 474-3 firm and level ground)†	9762 kg	21,515 lb	9307 kg	20,514 lb	8884 kg	19,581 lb	8492 kg	18,716 lb
3 Maximum overall length	9597 mm	377.8"	9902 mm	389.8"	10 207 mm	401.8"	10 511 mm	413.8"
4 Reach with forks at ground level	1284 mm	50.5"	1284 mm	50.5"	1284 mm	50.5"	1284 mm	50.5"
5 Ground to top of tine at minimum height and fork level	75 mm	3.0"	75 mm	3.0"	75 mm	3.0"	75 mm	3.0"
6 Reach with arms horizontal and forks level	1854 mm	73.0"	1854 mm	73.0"	1854 mm	73.0"	1854 mm	73.0"
7 Reach with fork at maximum height	808 mm	31.8"	808 mm	31.8"	808 mm	31.8"	808 mm	31.8"
8 Ground to top of tine with arms horizontal and fork level	1871 mm	73.6"	1871 mm	73.6"	1871 mm	73.6"	1871 mm	73.6"
9 Ground to top of tine at maximum height and fork level	4177 mm	164.4"	4177 mm	164.4"	4177 mm	164.4"	4177 mm	164.4"
10 Overall height of fork at full lift (top of carriage to ground)	5307 mm	208.9"	5307 mm	208.9"	5307 mm	208.9"	5307 mm	208.9"
11 Clearance at full lift and maximum dump	2803 mm	110.4"	2573 mm	101.3"	2343 mm	92.2"	2113 mm	83.2"
12 Maximum discharge angle from horizontal		49°		49°		49°		49°
13 Carriage width	2528 mm	99.5"	2528 mm	99.5"	2528 mm	99.5"	2528 mm	99.5"
14 Carriage height	1220 mm	48.0"	1220 mm	48.0"	1220 mm	48.0"	1220 mm	48.0"
15 Outside tine width (maximum spread)	2178 mm	85.7"	2178 mm	85.7"	2178 mm	85.7"	2178 mm	85.7"
16 Outside tine width (minimum spread)	576 mm	22.7"	576 mm	22.7"	576 mm	22.7"	576 mm	22.7"
Tine width (single tine)	180 mm	7.1"	180 mm	7.1"	180 mm	7.1"	180 mm	7.1"
Tine thickness	90 mm	3.5"	90 mm	3.5"	90 mm	3.5"	90 mm	3.5"
Operating weight	25 629 kg	56,486 lb	25 691 kg	56,623 lb	25 754 kg	56,762 lb	25 816 kg	56,898 lb

Based on 2438 mm (96") carriage, Fusion coupler and Fusion pallet fork.

Static tipping loads and operating weight are based on the following loader configuration: L3 Michelin XHA tires, air conditioning, ride control, power train guard, full fluids, fuel tank, coolant, lubricants, and operator. Static tipping loads conform to the international standard as defined in ISO* 14397-1 (Sept2007).

Specifications and ratings conform to the following standards: ISO 14397-1, SAE** J1197, SAE J732, CEN*** EN 474-3.

†Rated load is determined by considering % of machine stability, hydraulic lift capacity, and hydraulic tilt capacity. Please contact your dealer to properly select the machine configuration for handling target payloads in your specific machine application.

Machine and work tool availability varies by region. Contact your local Cat dealer for product availability.

The rated operating load for a loader equipped with a pallet fork is determined by:

- SAE J1197: 50% of full turn static tipping load or hydraulic limit.
- CEN EN 474-3: 60% of full turn static tipping load on rough terrain or hydraulic limit.
- CEN EN 474-3: 80% of full turn static tipping load on firm and level ground or hydraulic limit.

*ISO — International Organization for Standardization

**SAE — Society of Automotive Engineers

***CEN — European Committee for Standardization

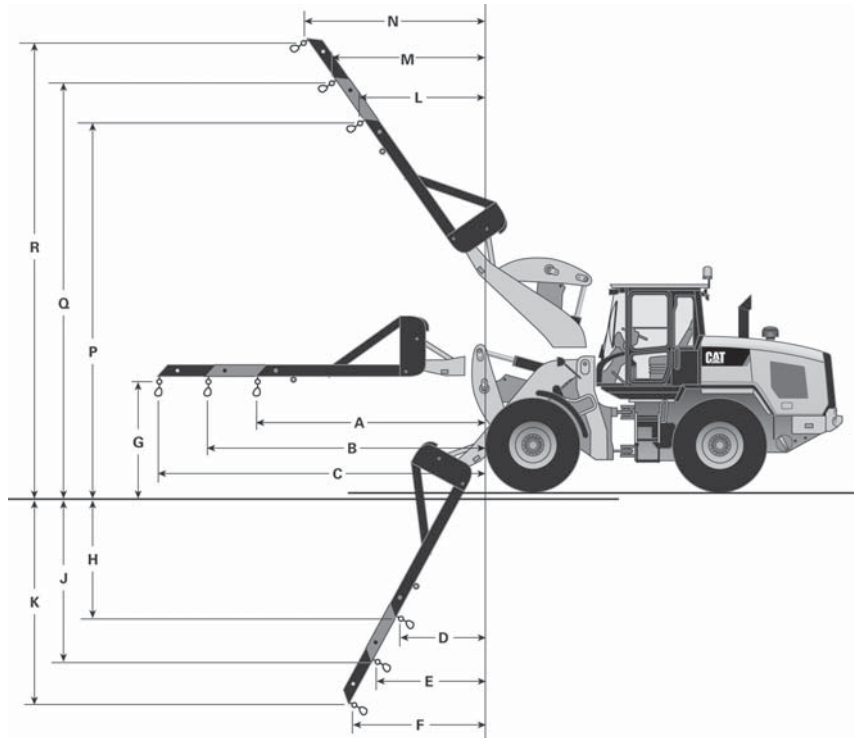

Dimensions listed are for a machine configured with Fusion work tool, standard counterweight, additional guarding, 80 kg (176 lb) operator, and Michelin 20.5 R25 (L-3) XHA2 tires.

MODEL	926M*		926M*	
	Standard		High Lift	
Operating load (retracted) @ full articulation	1928 kg	4250 lb	1631 kg	3595 lb
A Reach horizontal (retracted)	3727 mm	12'3"	4250 mm	13'11"
Operating load (mid-position) @ full articulation	1635 kg	3605 lb	1406 kg	3099 lb
B Reach horizontal (mid-position)	4527 mm	14'10"	5050 mm	16'7"
Operating load (extended) @ full articulation	1420 kg	3130 lb	1235 kg	2723 lb
C Reach horizontal (extended)	5327 mm	17'6"	5850 mm	19'2"
D Reach full down (retracted)	1045 mm	3'5"	1689 mm	5'6"
E Reach full down (mid-position)	1276 mm	4'2"	1922 mm	6'4"
F Reach full down (extended)	1507 mm	4'11"	2154 mm	7'1"
G Clearance horizontal	1854 mm	6'1"	1854 mm	6'1"
H Clearance full down (retracted)	2310 mm	7'7"	2343 mm	7'8"
J Clearance full down (mid-position)	3076 mm	10'1"	3109 mm	10'2"
K Clearance full down (extended)	3842 mm	12'7"	3874 mm	12'9"
L Reach at maximum height (retracted)	2333 mm	7'8"	2646 mm	8'8"
M Reach at maximum height (mid-position)	2919 mm	9'7"	3258 mm	10'8"
N Reach at maximum height (extended)	3505 mm	11'6"	3869 mm	12'8"
P Clearance at maximum height (retracted)	5568 mm	18'3"	5963 mm	19'7"
Q Clearance at maximum height (mid-position)	6112 mm	20'1"	6479 mm	21'3"
R Clearance at maximum height (extended)	6657 mm	21'10"	6995 mm	22'11"
Tires	20.5 R25 (L-3) XHA2		20.5 R25 (L-3) XHA2	

*Meets Tier 4 Final/Stage IV/Japan 2014 (Tier 4 Final) emission standards.

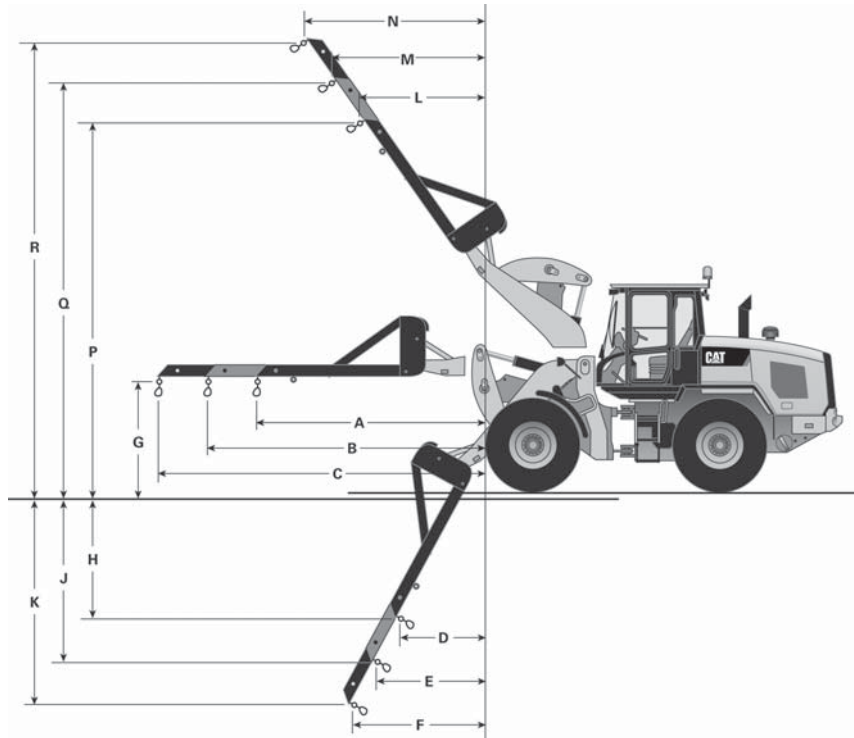

Dimensions listed are for a machine configured with Fusion work tool, heavy counterweight, additional guarding, 80 kg (176 lb) operator, and Michelin 20.5 R25 (L-3) XHA2 tires.

MODEL	930M*		930M*	
	Standard		High Lift	
Operating load (retracted) @ full articulation	2182 kg	4811 lb	1785 kg	3935 lb
A Reach horizontal (retracted)	3727 mm	12'3"	4380 mm	14'4"
Operating load (mid-position) @ full articulation	1851 kg	4081 lb	1544 kg	3404 lb
B Reach horizontal (mid-position)	4527 mm	14'10"	5180 mm	17'0"
Operating load (extended) @ full articulation	1607 kg	3543 lb	1360 kg	2999 lb
C Reach horizontal (extended)	5327 mm	17'6"	5980 mm	19'7"
D Reach full down (retracted)	1045 mm	3'5"	1908 mm	6'3"
E Reach full down (mid-position)	1276 mm	4'2"	2160 mm	7'1"
F Reach full down (extended)	1507 mm	4'11"	2412 mm	7'11"
G Clearance horizontal	1854 mm	6'1"	1854 mm	6'1"
H Clearance full down (retracted)	2310 mm	7'7"	2327 mm	7'8"
J Clearance full down (mid-position)	3076 mm	10'1"	3087 mm	10'2"
K Clearance full down (extended)	3842 mm	12'7"	3846 mm	12'7"
L Reach at maximum height (retracted)	2333 mm	7'8"	2689 mm	8'10"
M Reach at maximum height (mid-position)	2919 mm	9'7"	3287 mm	10'9"
N Reach at maximum height (extended)	3505 mm	11'6"	3885 mm	12'9"
P Clearance at maximum height (retracted)	5568 mm	18'3"	6116 mm	20'1"
Q Clearance at maximum height (mid-position)	6112 mm	20'1"	6647 mm	21'10"
R Clearance at maximum height (extended)	6657 mm	21'10"	7178 mm	23'7"
Tires	20.5 R25 (L-3) XHA2		20.5 R25 (L-3) XHA2	

*Meets Tier 4 Final/Stage IV/Japan 2014 (Tier 4 Final) emission standards.

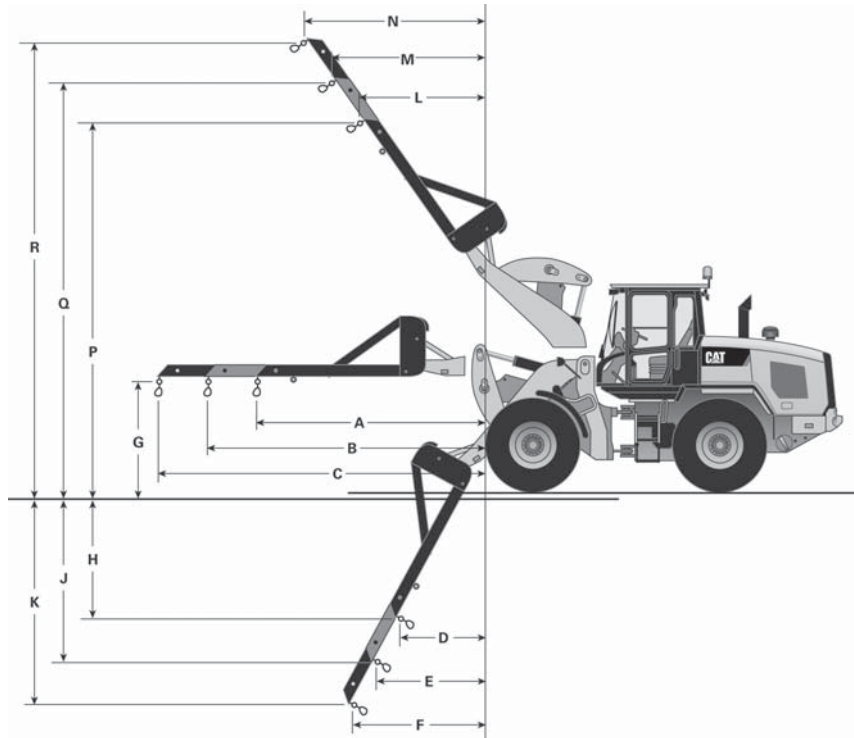

Dimensions listed are for a machine configured with Fusion work tool, heavy counterweight, additional guarding, 80 kg (176 lb) operator, and Michelin 20.5 R25 (L-3) XHA2 tires.

MODEL	938M*		938M*	
	Standard		High Lift	
Operating load (retracted) @ full articulation	2637 kg	5814 lb	2092 kg	4612 lb
A Reach horizontal (retracted)	3775 mm	12'5"	4383 mm	14'5"
Operating load (mid-position) @ full articulation	2241 kg	4940 lb	1810 kg	3990 lb
B Reach horizontal (mid-position)	4575 mm	15'0"	5183 mm	17'0"
Operating load (extended) @ full articulation	1948 kg	4294 lb	1594 kg	3515 lb
C Reach horizontal (extended)	2512 mm	8'3"	5983 mm	19'8"
D Reach full down (retracted)	1089 mm	3'6"	1873 mm	6'2"
E Reach full down (mid-position)	1324 mm	4'4"	2121 mm	7'0"
F Reach full down (extended)	1559 mm	5'1"	2369 mm	7'9"
G Clearance horizontal	1890 mm	6'2"	1890 mm	6'2"
H Clearance full down (retracted)	2316 mm	7'7"	2340 mm	7'8"
J Clearance full down (mid-position)	3081 mm	10'1"	3100 mm	10'2"
K Clearance full down (extended)	3846 mm	12'7"	3861 mm	12'8"
L Reach at maximum height (retracted)	2361 mm	7'9"	2679 mm	8'9"
M Reach at maximum height (mid-position)	2943 mm	9'8"	3277 mm	10'9"
N Reach at maximum height (extended)	3525 mm	11'7"	3874 mm	12'9"
P Clearance at maximum height (retracted)	5655 mm	18'7"	6174 mm	20'3"
Q Clearance at maximum height (mid-position)	6204 mm	20'4"	6706 mm	22'0"
R Clearance at maximum height (extended)	6754 mm	22'2"	7238 mm	23'9"
Tires	20.5 R25 (L-3) XHA2		20.5 R25 (L-3) XHA2	

*Meets Tier 4 Final/Stage IV/Japan 2014 (Tier 4 Final) emission standards.

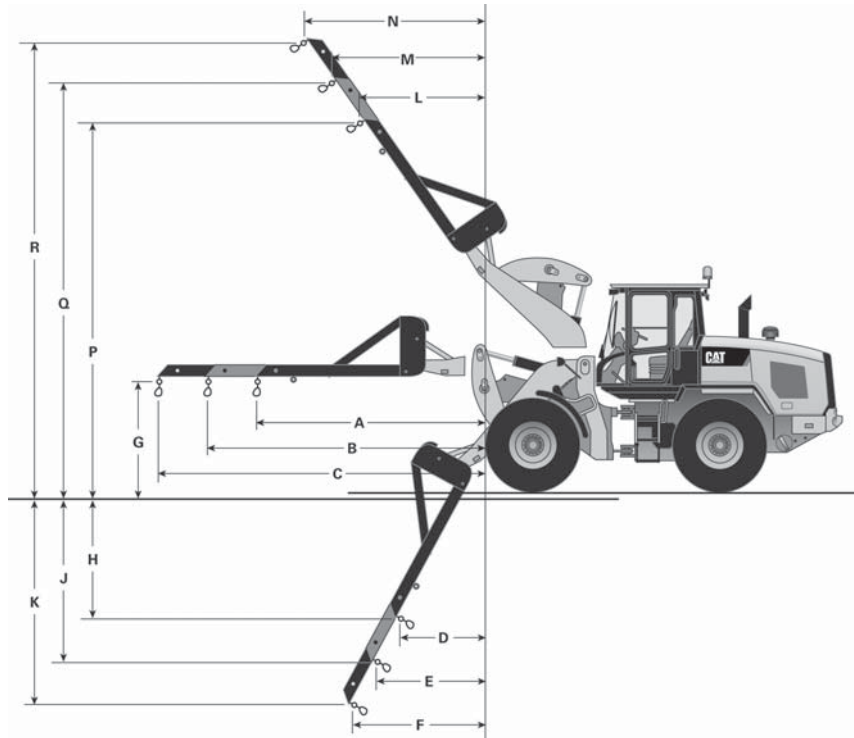

MODEL	924K Standard	
A Operating load (retracted) @ full articulation	1853 kg	4085 lb
B Reach horizontal (retracted)	3680 mm	12'0"
C Operating load (mid-position) @ full articulation	1569 kg	3459 lb
D Reach horizontal (mid-position)	4480 mm	14'8"
E Operating load (extended) @ full articulation	1361 kg	2999 lb
F Reach horizontal (extended)	5280 mm	17'3"
G Clearance horizontal	1823 mm	5'11"
H Reach full down (retracted)	373 mm	1'2"
J Reach full down (mid-position)	411 mm	1'4"
K Reach full down (extended)	448 mm	1'5"
L Clearance full down (retracted)	2381 mm	7'9"
M Clearance full down (mid-position)	3180 mm	10'5"
N Clearance full down (extended)	3979 mm	13'0"
P Reach at maximum height (retracted)	2551 mm	8'4"
Q Reach at maximum height (mid-position)	3223 mm	10'6"
R Reach at maximum height (extended)	3896 mm	12'9"
S Clearance at maximum height (retracted)	5134 mm	16'10"
T Clearance at maximum height (mid-position)	5567 mm	18'3"
U Clearance at maximum height (extended)	6000 mm	19'8"
Tires	Michelin 20.5 R25 (L-3) XHA2	

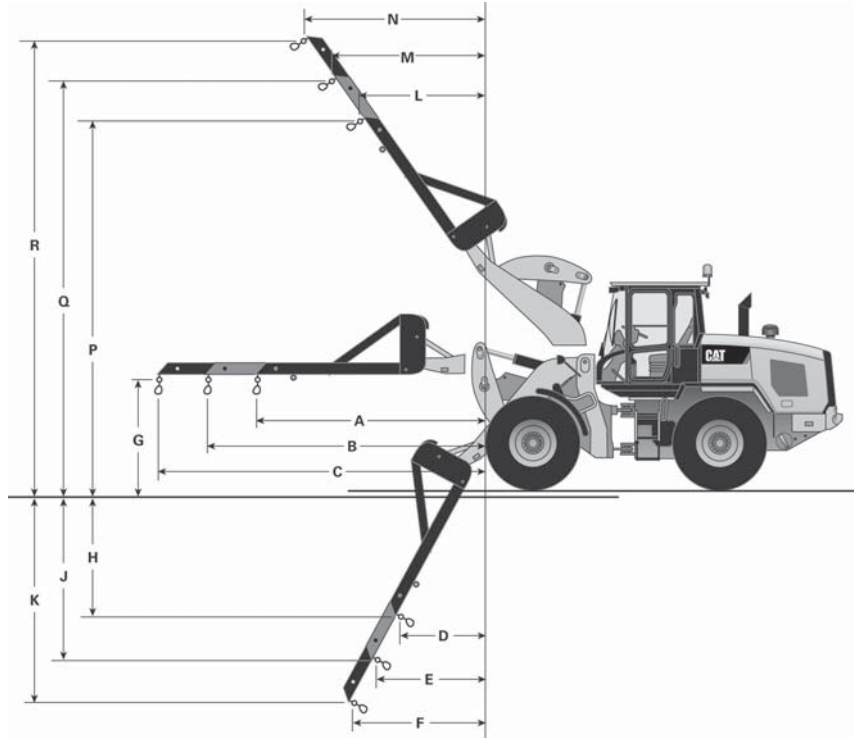

MODEL	930K		938K	
	Standard		Standard	
A Rated operating load (retracted) @ full articulation	2135 kg	4706 lb	2534 kg	5586 lb
B Reach horizontal (retracted)	3727 mm	12'2"	3775 mm	12'4"
C Rated operating load (mid-position) @ full articulation	1811 kg	3992 lb	2153 kg	4746 lb
D Reach horizontal (mid-position)	4527 mm	14'10"	4575 mm	15'0"
E Rated operating load (extended) @ full articulation	1572 kg	3466 lb	1871 kg	4125 lb
F Reach horizontal (extended)	5327 mm	17'5"	5376 mm	17'7"
G Clearance horizontal	1854 mm	6'0"	1890 mm	6'2"
H Reach full down (retracted)	1045 mm	3'5"	1089 mm	3'6"
J Reach full down (mid-position)	1276 mm	4'2"	1324 mm	4'4"
K Reach full down (extended)	1507 mm	4'11"	1559 mm	5'1"
L Clearance full down (retracted)	2310 mm	7'6"	2316 mm	7'7"
M Clearance full down (mid-position)	3076 mm	10'1"	3081 mm	10'1"
N Clearance full down (extended)	3842 mm	12'7"	3846 mm	12'7"
P Reach at maximum height (retracted)	2333 mm	7'7"	2362 mm	7'8"
Q Reach at maximum height (mid-position)	2919 mm	9'6"	2943 mm	9'7"
R Reach at maximum height (extended)	3505 mm	11'6"	3525 mm	11'6"
S Clearance at maximum height (retracted)	5568 mm	18'3"	5655 mm	18'6"
T Clearance at maximum height (mid-position)	6112 mm	20'0"	6204 mm	20'4"
U Clearance at maximum height (extended)	6657 mm	21'10"	6754 mm	22'1"
Tires	Michelin 20.5 R25 (L-3) XHA2		Michelin 20.5 R25 (L-3) XHA2	

SPECIFICATION DEFINITIONS FOR FRONT END LOADERS

Cat wheel and track loader specifications conform to Society of Automotive Engineers (SAE) definitions as expressed in standards J732 (JUN92), as follows:

Description of Specification Machine

On wheel loaders the tire inflation pressure at which specifications are taken must be described in addition to the current written basic machine description. On track loaders the type of grouser must be specified.

Hydraulic Cycle Times

- a. "Raise Time" — Time in seconds required to raise the bucket from level position on the ground.
- b. "Lower Time" — Time in seconds required to lower the empty bucket from the full height to a level position on the ground.
- c. "Dump Time" — Time in seconds required to move the bucket at maximum height from the maximum rollback position to full dump position while dumping the SAE loose material operating load.

Breakout Force

"Breakout force," pounds (and kilonewtons or kilograms) — the maximum sustained vertical upward force exerted 100 mm (4") behind the tip of the bucket cutting edge and achieved through the ability to lift and/or rollback about the specified pivot point under the following conditions:

- a. Loader on a hard level surface with transmission in neutral.
- b. All brakes released.
- c. Unit at standard operating weight — rear of loader not tied down.
- d. Bottom of cutting edge parallel to and not more than 20 mm (0.75") above or below the ground line.

- e. When bucket circuit is used the pivot point must be specified as the bucket hinge pin, and the unit blocked under the bucket hinge pin pivot point in order to minimize linkage movement.
- f. When the lift circuit is used, the pivot point must be specified as the lift arm hinge pin. Wheel loaders shall have front axle blocked to eliminate change in position of pivot pins due to tire deflection.
- g. If both circuits are used simultaneously, the dominating pivot point listed in (e) or (f) must be specified.
- h. If the circuit used causes the rear of the vehicle to leave the ground, then the vertical force value required to raise the rear of the vehicle is the breakout force.
- i. For irregular shaped buckets, the tip of the bucket cutting edge referred to above shall mean the farther forward point of the cutting edge.

The following are illustrations used (according to provisions of SAE J732 JUN92) to measure Cat Loader breakout forces.

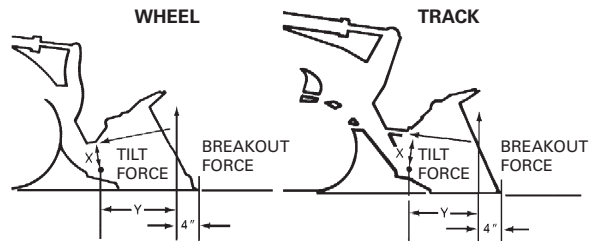

- a. Breakout force resulting from rack back:
 $(\text{Tilt Force}) \times (\text{Dist. "X"}) = (\text{"Y" Dist.}) \times (\text{Breakout Force})$

$$\frac{(\text{Tilt Force}) \times (\text{Dist. "X"})}{\text{"Y" Dist.}} = \text{Breakout Force}$$

b. Breakout force resulting from bucket lift:

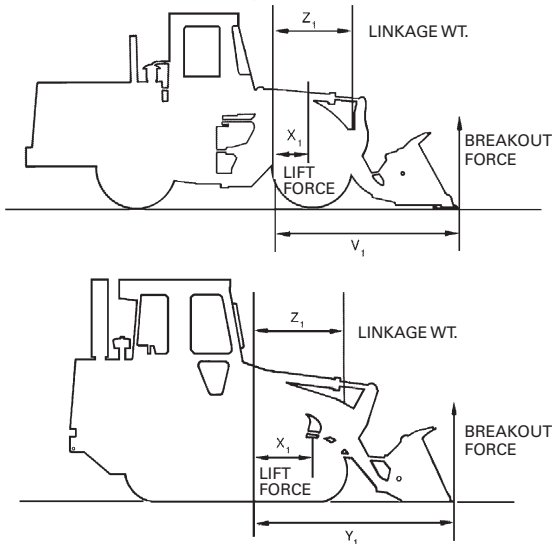

$$\begin{aligned}
 (\text{Lift Force}) \times (\text{Dist. "X}_1\text{")} &= (\text{"Y}_1\text{ Dist.}) \times (\text{Breakout Force}) \\
 &+ (\text{Linkage Wt.}) \times (\text{Dist. "Z}_1\text{")} \\
 &+ (\text{Breakout Force}) \times (\text{Linkage Mechanical Advantage "V}_1\text{") \\
 &\quad \text{or} \\
 (\text{Lift Force}) \times (\text{Dist. "X}_1\text{")} - &(\text{Linkage Wt.}) \times (\text{Dist. "Z}_1\text{")} \\
 \text{Breakout Force} = &\frac{(\text{Dist. "Y}_1\text{") + (\text{Dist. "V}_1\text{") \times}}{(\text{Linkage Mech. Advantage})}
 \end{aligned}$$

Static Tipping Load

The minimum weight at center of gravity of "SAE Rated" load in bucket which will rotate rear of machine to a point where, on track loaders, front rollers are clear of the track and on wheel loaders, rear wheels are clear of the ground under the following conditions:

- Loader on hard level surface and stationary.
- Unit at standard operating weight.
- Bucket at maximum rollback position.
- Load at maximum forward position during raising cycle.
- For articulated wheel loaders, the test will be run both with frame straight (straight static tipping load) and fully turned to a specific angle (full turn static tipping load).
- Unit with standard equipment as described in specifications unless otherwise noted under the heading.

Operating Load

In order to comply with SAE standard J818 MAY87, the operating load of Wheel Loaders should not exceed 50% of the full turn Static Tipping load of the machine when equipped with attachments needed for the job. (For track loaders, operating load should not exceed 35% of the Static Tipping load rating.) See "Performance Data" of each machine in this handbook for increases to static tipping load by adding cab, counterweights, ripper-scarifier, etc.

The SAE operating load is not an indication of a wheel loader's rated payload. It takes into consideration only hydraulic lift and tipping capacity. There is no regard to structural and/or component lives, and for wheel loaders is measured on hard, moderately smooth and level operating surfaces.

Carry Position

SAE defines carry positions as: "The vertical distance from the ground to the center line of the bucket hinge pin, with the angle of approach at 15°." The sketch below illustrates this definition:

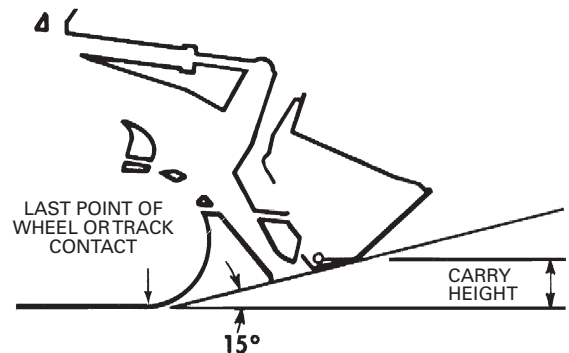
**Loader Clearance Circle**

SAE J732 JUN92 states that "minimum turning radius (over tire)" and "loader clearance circle" should be given for wheel loaders. Both are given on Cat specification sheets, including loader clearance circles for all available buckets for each machine.

Digging Depth

J732 JUN92 specifies digging depth as "the vertical distance in mm (inches) from the ground line to the bottom of the bucket cutting edge at the lowest position with the bucket cutting edge horizontal."

SAE BUCKET RATING

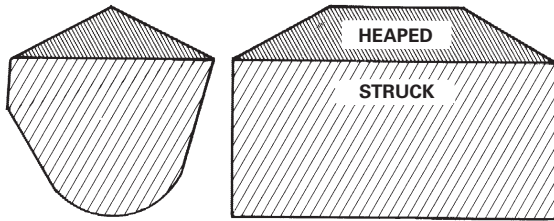

SAE Bucket Capacities

Struck capacity is that volume contained in a bucket after a load is leveled by drawing a straight edge resting on the cutting edge and the back of the bucket.

Heaped capacity is a struck capacity plus that additional material that would heap on the struck load at a 2:1 angle of repose with the struck line parallel to the ground.

SAE J742 (FEB85) specifies that the addition of any auxiliary spill guard to protect against spillage which might injure the operator will not be included in bucket capacity ratings. Buckets with irregular shaped cutting edges (vee edge) the strike plane should be drawn at one-third the distance of the protruding portion of the cutting edge. Cat rock buckets are built with integral see-through rock guards. Cat light material buckets come standard with bolt-on edges. These features which add to actual bucket capacity are included in published ratings.

Dump Height

SAE J732 JUN92 specifies that dump height is the vertical distance from the ground to the lowest point of the cutting edge with the bucket hinge pin at maximum height and the bucket at a 45° dump angle. Dump angle is the angle in degrees that the longest flat section of the inside bottom of the bucket will rotate below horizontal.

SELECTING A MACHINE

Steps in selecting the proper size loader:

1. Determine production required or desired.
2. Determine loader cycle time and cycles per hour. A machine size must be assumed to select a basic cycle time.

3. Determine required payload per cycle in loose cubic yards and pounds (meters and kilograms).
4. Determine bucket size needed.
5. Make machine selection using bucket size and payload as criteria to meet production requirements.
6. Compare the loader cycle time used in calculations to the cycle time of the machine selected. If there is a difference, rework the process beginning at step 2.

1. Production Required

The production required of a wheel or track loader should be slightly greater than the production capability of the other critical units in the earth or material moving system. For example, if a hopper can handle 300 tons per hour, a loader capable of slightly more than 300 tons should be used. Required production should be carefully calculated so the proper machine and bucket selections are made.

2. Loader Cycle Times

When hauling loose granular material on a hard smooth operating surface, a .45-.55 minute basic cycle time is considered reasonable for Cat articulated loaders with a competent operator. This includes load, dump, four reversals of direction, full cycle of hydraulics and minimum travel.

Material type, pile height, and other factors may improve or reduce production, and should be added to or subtracted from the basic cycle time when applicable.

When hauls are involved, obtain the haul and return portion of the cycle from the estimated travel chart (this section). Add the haul and return times to the estimated basic cycle time to obtain total cycle time.

CYCLE TIME FACTORS

A basic cycle time (Load, Dump, Maneuver) of .45-.55 minutes is average for an articulated loader [the basic cycle for large loaders, 3 m³ (4 yd³) and up, can be slightly longer], but variations can be anticipated in the field. The following values for many variable elements are based on normal operations. Adding or subtracting any of the variable times will give the total basic cycle time.

Minutes added (+)
 or Subtracted (-)
 From Basic Cycle

<i>Machine</i>	
— Material handler	-.05
<i>Materials</i>	
— Mixed	+.02
— Up to 3 mm (1/8 in)	+.02
— 3 mm (1/8 in) to 20 mm (3/4 in)	-.02
— 20 mm (3/4 in) to 150 mm (6 in)00
— 150 mm (6 in) and over	+.03 and Up
— Bank or broken	+.04 and Up
<i>Pile</i>	
— Conveyor or Dozer piled 3 m (10 ft) and up00
— Conveyor or Dozer piled 3 m (10 ft) or less	+.01
— Dumped by truck	+.02
<i>Miscellaneous</i>	
— Common ownership of trucks and loaders	Up to -.04
— Independently owned trucks	Up to +.04
— Constant operation	Up to -.04
— Inconsistent operation	Up to +.04
— Small target	Up to +.04
— Fragile target	Up to +.05

Using actual job conditions and the above factors, total cycle time can be estimated. Convert total cycle time to cycles per hour.

$$\text{Cycles per hour at 100\% Efficiency} = \frac{60 \text{ min}}{\text{Total Cycle Time in Minutes}}$$

Job efficiency is an important factor in machine selection. Efficiency is the actual number of minutes worked during an hour. Job efficiency accounts for bathroom breaks and other work interruptions.

$$\begin{array}{l} \text{Cycles per hour at 50 minutes per hour (83\% efficiency)} \\ \text{Cycles per hour at 100\% efficiency} \end{array} = \frac{50 \text{ min} \times \text{actual work time}}{60 \text{ min hour}}$$

TRUCK LOADING

Average loader cycle times

910K-962H	0.45-0.50 min
966H-980H	0.50-0.55 min
986H-990K	0.55-0.60 min
992K-994K	0.60-0.70 min

3. Required Payload Per Cycle

Required payload per cycle is determined by dividing required hourly production by the number of cycles per hour.

4. Bucket Selection

After required payload per cycle has been calculated, the payload should be divided by the loose cubic yard (meter) material weight to determine number of loose cubic yards (meters) required per cycle.

The bulk of material handled does not weigh 1800 kg/m³ (3000 lb/yd³), so a reasonable knowledge of material weight is necessary for accurate production estimates. The Tables Section has average weight for certain materials when actual weights are not known.

The percentage of rated capacity a bucket carries in various materials is estimated below. The bucket size required to handle the required volume per cycle is found with the aid of the percentage of rated bucket capacity called "Bucket Fill Factor."

The bucket size needed is determined by dividing loose cubic meters (or yards) required per cycle by the bucket fill factor.

$$\text{Bucket size} = \frac{\text{Volume Required/Cycle}}{\text{Bucket Fill Factor}}$$

BUCKET FILL FACTORS

The following indicates the approximate amounts of material as a percent of rated bucket capacity which will actually be delivered per bucket per cycle. This is known as "Bucket Fill Factor."

Loose Material	Fill factor
Mixed moist aggregates	95-100%
Uniform aggregates up to 3 mm (1/8 in)	95-100
3 mm (1/8 in) to 9 mm (3/8 in)	90-95
12 mm (1/2 in) to 20 mm (3/4 in)	85-90
24 mm (1.0 in) and over	85-90

Wheel Loaders Integrated Toolcarriers

Machine Selection

- Bucket Fill Factors
- Example Problem

Blasted Rock

Well blasted	80-95%
Average	75-90
Poor	60-75

Other

Rock dirt mixtures	100-120%
Moist loam	100-110
Soil, boulders, roots	80-100
Cemented materials	85-95

NOTE: Fill factors on wheel loaders are affected by bucket penetration, breakout force, rack back angle, bucket profile and ground engaging tools such as bucket teeth or bolt-on replaceable cutting edges.

Example:

12 mm (1/2 in) material and 3 m³ (4 yd³) bucket.
 0.90 × 3 m³ = 2.75 Loose m³ delivered per cycle.
 0.90 × 4 yd³ = 3.6 Loose yd³ delivered per cycle.

NOTE: Check the static tipping load on the specific machine to determine if bucket load is in fact a safe operating load.

Bucket Selection

$$\text{Tons Required/Cycle} = \frac{\text{Tons Required/Hour}}{\text{Cycles/Hour}}$$

$$\text{Kg (Pounds) Required/Cycle} = \frac{\text{Tons Required/Cycle} \times 907 \text{ kg (2000 lb)}}{\text{Cycles/Hour}}$$

$$\text{Volume Required/Cycle} = \frac{\text{kg (Pounds) Cycle}}{\text{Material Weight kg/m}^3 \text{ (lb/yd}^3\text{)}}$$

Always select a machine with a greater capacity than the calculated required operating capacity. For most applications, payload above recommended and excessive counterweight can hinder machine performance and reduce dynamic stability and machine life.

For optimum performance in fast cycling situations such as truck loading, operating loads should not exceed the recommended capacity. To provide extra stability, calcium chloride (CaCl₂) ballast may be desired when operating at recommended operating load, see SAE Loader rating pages in this section. For specific stability data and optional tire sizes, see the "Performance Data" pages in this section.

When selecting special application buckets, such as multi-purpose and side dump the additional bucket weight must be deducted from recommended capacity.

Specific circumstances may involve other conditions which would also affect loader capacity. Because of the greatly varied applications and conditions, your Cat dealer should be contacted for guidance.

Example problem:

JOB CONDITIONS

Application	Truck loading
Production Required	450 metric ton (496 Tons) per hour
Material	9 mm (3/8") gravel in 6 m (20 ft) high stockpile
Density	1660 kg/m ³ (2800 lb/yd ³)

Trucks are 6-9 m³ (8-12 yd³) capacity and are owned by three contractors. Loading is constant. Hard level surface for loader maneuvering.

1. **PRODUCTION REQUIRED:** Given
2. **CYCLE TIME:** Assume loader size between 910K and 962H for initial choice of basic cycle.

(Refer to Cycle Time Factors in this section)

Independent trucks	.04 min
Basic Cycle	.50 min
Material	-.02 min
Independent trucks	+.04 min
Constant operation	-.02 min
Total Cycle	.50 min

NOTE: Load and carry times not required in total cycle.

$$\begin{aligned} \text{Cycles/hr at 83\% efficiency} &= \frac{120 \text{ cycles/hr} \times \frac{50 \text{ min actual work time}}{60 \text{ min per hr}}}{100} \\ &= 100 \text{ cycles/hr} \end{aligned}$$

3. **VOLUME REQUIRED PER CYCLE**

(Density in tons)

Density in this example was given. When not given, refer to Tables Section to obtain an estimated density for the material being handled.

$$\text{Metric: } \frac{1660 \text{ kg/m}^3}{1000 \text{ kg/ton}} = 1.66 \text{ ton/m}^3$$

$$\text{English: } \frac{2800 \text{ lb/yd}^3}{2000 \text{ lb/ton}} = 1.4 \text{ tons/yd}^3$$

Production Rate Required

$$\text{Metric: } \frac{450 \text{ tons/hr}}{1.66 \text{ tons/m}^3} = 271 \text{ m}^3/\text{hr}$$

$$\text{English: } \frac{496 \text{ tons/hr}}{1.4 \text{ tons/yd}^3} = 354 \text{ yd}^3/\text{hr}$$

Volume Required per Cycle

$$\text{Metric: } \frac{271 \text{ m}^3/\text{hr}}{100 \text{ cycles/hr}} = 2.71 \text{ m}^3/\text{cycle}$$

$$\text{English: } \frac{354 \text{ yd}^3/\text{hr}}{100 \text{ cycles/hr}} = 3.54 \text{ yd}^3/\text{cycle}$$

4. DETERMINE BUCKET SIZE

BUCKET FILL FACTOR

The volume of material required per cycle has been determined. Because of varying material fill factors, buckets do not always carry their rated load, a larger capacity bucket may be needed to carry the volume required. For fill factors, refer to Bucket Fill Factor Chart in this section.

Rated Bucket Capacity Required (Heaped)

$$\frac{2.71 \text{ m}^3/\text{cycle}}{0.95 \text{ fill factor}} = 2.85 \text{ m}^3$$

$$\frac{3.54 \text{ yd}^3/\text{cycle}}{0.95 \text{ fill factor}} = 3.73 \text{ yd}^3$$

A 2.9 m³ (3.75 yd³) bucket would provide the required capacity.

5. MACHINE SELECTION

The bucket size required and material density lead to the choice of a 950H with a 2.9 m³ (3.75 yd³) General Purpose Bucket (see bucket selection guide pages which follow.)

Finally, SAE payload criteria must be satisfied as follows:

The required operating capacity must not exceed one-half of the full turn static tipping load of the loader as equipped with a specific bucket.

The required operating capacity of the machine is determined by the volume the machine will carry per load times the density.

$$2.9 \text{ m}^3 \times 1660 \text{ kg/m}^3 = 4814 \text{ kg}$$

$$(3.75 \text{ yd}^3 \times 2800 \text{ lb/yd}^3 = 10,500 \text{ lb})$$

One half of full turn static tipping load for the 950H with a 2.9 m³ (3.75 yd³) General Purpose Bucket is 5410 kg (11,925 lb). SAE criteria is satisfied.



An Alternative Method of Machine Selection

Another method of selecting the right Wheel Loader and bucket to meet production requirements is by use of the nomographs on the following pages. The method is quicker and easier than the preceding example because it does not require as many calculations, yet the accuracy is about the same within the normal limits of input data.

Be careful when entering and reading data from the nomographs because some scales increase from bottom to top, while others are the reverse. Do not be overly concerned with the precision as affected by pencil line width or reading to the hundredth of a m³ (yd³). Remember that bucket fill factor, material density and cycle time are at best close estimates.

Example problem:

A Wheel Loader must produce 230 m³ (300 yd³) per hour in a truck loading application. Estimated cycle time is .6 minutes, working 45 minutes per hour. Bucket fill factor is 95% and material density is 1780 kg/m³ (3000 lb/yd³).

Determine bucket size and machine model.

Solution:

At full efficiency, the Wheel Loader will cycle 100 times per hour. Since only an average of 45 minutes are available, only 75 cycles will be completed.

Starting on Scale A at 75 cycles per hour draw a straight line intersecting 230 m³/hr (300 yd³/hr) on Scale B and extending it on to Scale C giving 3 m³/cycle (4 yd³/cycle) required payload. Follow solution steps 1-10.

Wheel Loaders Integrated Toolcarriers

Production and Machine Selection Nomograph

- To find required bucket payload and bucket size

1. Enter required hourly production on Scale B 230 m³/hr (300 yd³/hr).
2. Enter cycles per hour on Scale A (60 ÷ .6 = 100 × .75 = 75 cycles/hr).
3. Connect A through B to C. This shows a required payload of 3 m³ (4 yd³) per cycle.
4. Enter estimated bucket fill factor on Scale D (0.95).
5. Connect C through Scale D to E for required bucket size 3 m³ (4 yd³).
6. Transfer cycles per hour Scale A and required payload Scale C to the following page.

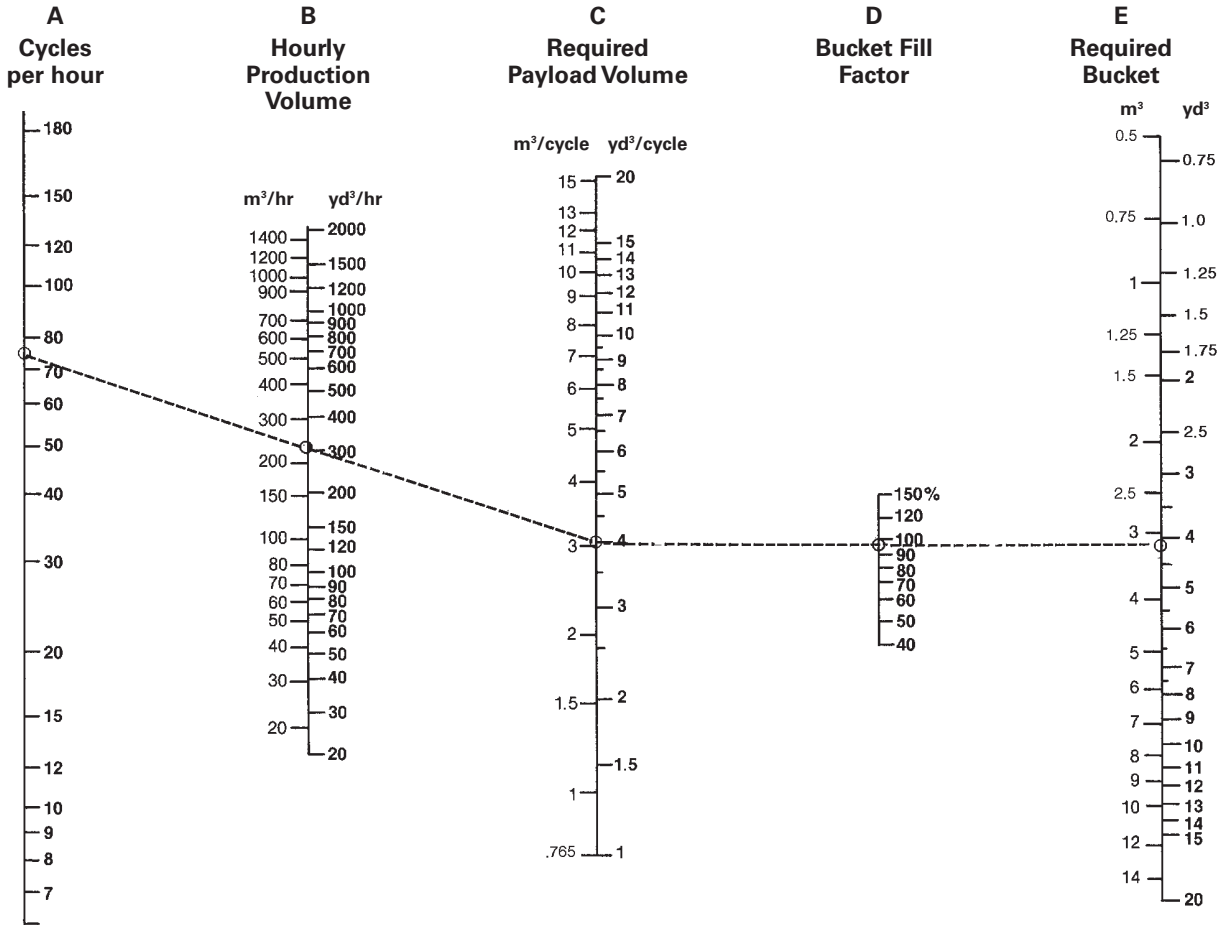

Production and Machine Selection Nomograph

- To find payload weight and tons per hour

Wheel Loaders Integrated Toolcarriers

- Enter material density on Scale F 1780 kg/m³ (3000 lb/yd³).
- Connect C through Scale F to Scale G to give payload weight per cycle 5300 kg (11,500 lb).
- Compare Scale G quantity 5300 kg (11,500 lb) with recommended machine working range listed on the following bucket selection pages.

Operating capacity for the 950H with 3.1 m³ (4 yd³) bucket is dependent on material density and bucket capacity (see bucket selection pages that follow).

- For hourly tonnage, draw a straight line from Scale G through Scale A to Scale I metric tons (450 U.S. tons).

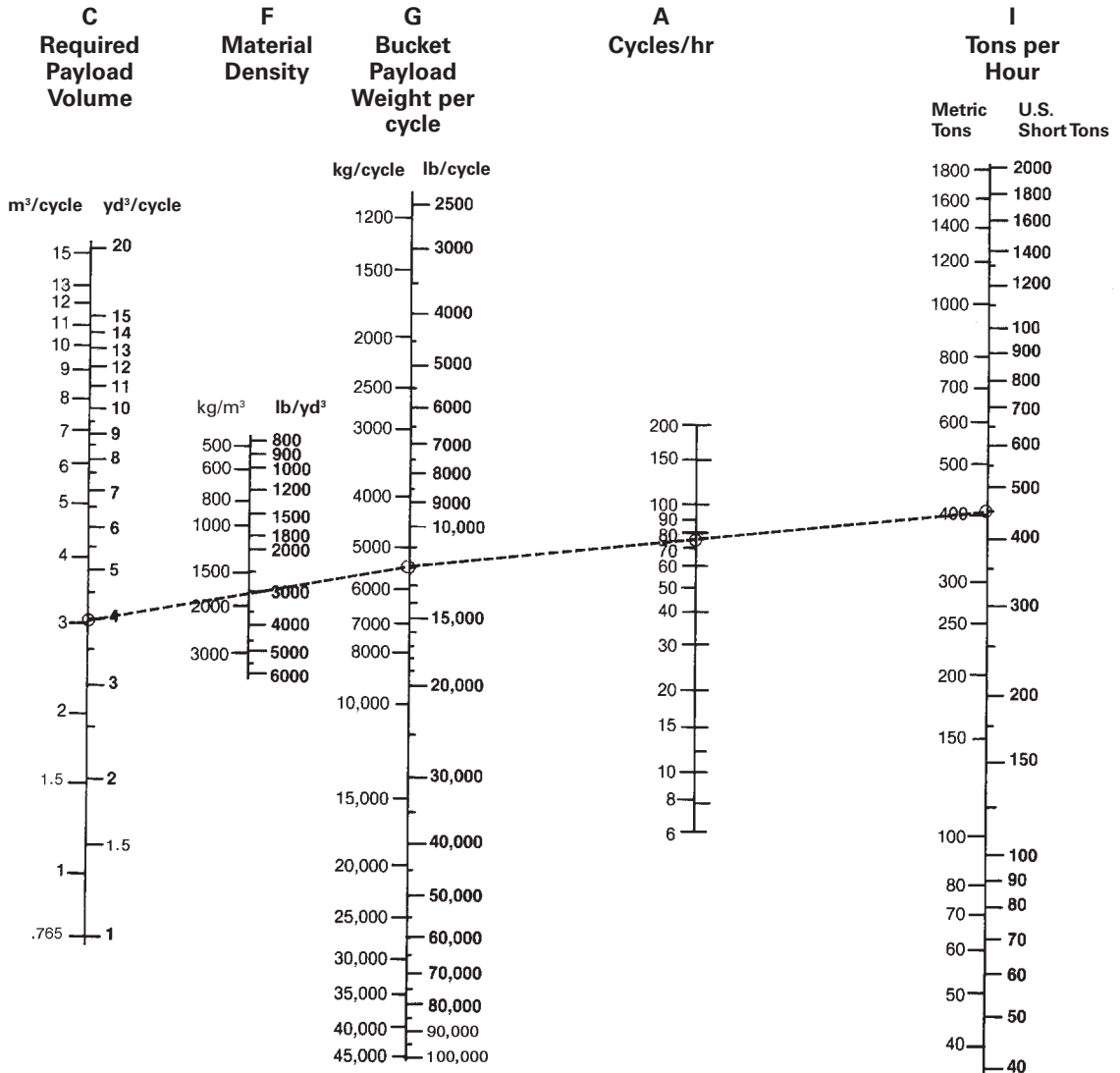

MACHINE/ATTACHMENT SELECTION

The Integrated Toolcarrier’s versatility and the wide range of attachments makes the “single machine fleet” concept highly attractive to an increasing number of users.

A Job Analysis helps identify applications, work requirements, material handling parameters and the current working method. Thoroughly research each element in the following chart, the gathered information will help select the proper Integrated Toolcarrier System.

JOB ANALYSIS METHOD

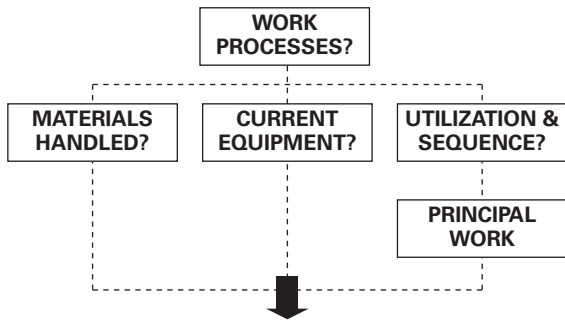

● **APPROPRIATE INTEGRATED TOOLCARRIER MODEL SIZE**

● **NECESSARY ATTACHMENTS**

Work Processes:

The first step in the job analysis is to identify all work processes from start to finish. Key questions outlined below will begin to indicate the required attachments and potential Integrated Toolcarrier applications.

- What kinds of work are performed: (e.g., dozing, loading, stacking, digging, sweeping, handling special materials, etc.)
 - ... in site preparation?
 - ... below ground level?
 - ... at ground level?
 - ... above ground level?
 - ... in landscaping?
 - ... in maintenance equipment yard?
 - etc.
- What work is done manually that could be done with an Integrated Toolcarrier?
- What are the work conditions?:
 - ... underfoot?
 - ... grades?
 - ... tight quarters?
 - ... time restraints?
 - ... climate?
 - etc.

Materials Handled:

Examining the materials handled will assist in determining necessary attachments. Sizes and weights of material(s) handled will indicate the appropriate Integrated Toolcarrier model by defining lift and reach requirements. Concentrate on the material flow at the job site — the point of origin as well as the final destination for the various materials will undoubtedly have material handling requirements.

- What kinds of materials are handled (e.g. snow, earth, bricks, chemicals, pipe, logs, etc.)
- What form are the materials handled in: bulk? palletized?
- How much does each weigh?
- What are the dimensions of each?
- What are the... movement parameters:
 - ... dozed what distance?
 - ... load and carried what distance?
 - ... lifted how high?
 - ... placed below ground level?
 - ... placed what distance from machine?

Current Equipment:

If determining material weight is not possible, much information can be determined from looking at the current equipment fleet. This will suggest required performance capabilities such as lifting capacity.

- Machines currently doing the work (e.g. wheel loaders, lift trucks, sweepers, light capacity cranes, snow plows, etc.)?
- What special (maximum) capabilities does each machine have (production, lift height, load capacity, width/height dimensions, reach, turning radius, travel speed, etc.)?
- To what extent are each machine's maximum capabilities used?
- What are owning/operating costs of each?

Utilization & Sequence:

Utilization implies how often the current machines are used and what will be the utilization factors for the Integrated Toolcarrier with each individual attachment. Sequence implies what order these tasks are accomplished in and if two or more machines operate at the same time. This portion of the job analysis should assist in comparing economies of various systems. Other important considerations may be the number of operators needed, storage space, reduced maintenance requirements, etc.

- How often (what percent) is each machine used?
- How often and when does it sit idle?
- How often and when do two or more machines work at the same time?
- Can the operation be changed to permit single machine operation?

Principal Work:

Utilization and sequence will indicate the principal work the Integrated Toolcarrier will do, further assisting in attachment and model sizing and selection. The basic machine/tool package should be able to handle the toughest, most frequently performed jobs for the primary application. Secondary tools can have a little more "give and take" in their performance capabilities than the primary tool.

- What work can be accomplished by an Integrated Toolcarrier?
- What work will take up the majority of Integrated Toolcarrier time?
- What work will use the maximum static tipping capabilities of the Integrated Toolcarrier?
- What high cost (owning and operating) and/or low utilization machines can be replaced by an Integrated Toolcarrier?

Additional Tips for Tool Sizing and Selection

Tool selection will principally concern hydraulic power requirements and static tipping load considerations. The standard tools offered by Caterpillar can be used on any Integrated Toolcarrier machine with little difficulty. However, tools such as the hydraulic broom, claws, blades and asphalt cutter will require additional consideration before proposing a system to the customer.

Fork Rating

ISO 14397-1 states that articulated wheel loaders require the following method for calculating rated load on forks. 50% of the fully articulated tipping load when the lift arms and fork are level, and the load is applied at a point on the longitudinal center line of the machine at half the distance from the most rearward point of the load opening to the tip of the fork, this will be the rated load for that machine in its present configuration. As the machine configuration changes, so does the rated load. EN474-3 states a load center dependent on the value of the load itself. Please refer to that standard for the load center location table. Always refer to the manufacturer of the fork to determine the load rating for the fork tine.

Bucket Rating

Bucket capacity, SAE J742 FEB85 (nominally heaped)

ISO 14397-1 states that articulated wheel loaders require the following method for calculating rated load, also known as the maximum payload, with buckets. 50% of the fully articulated tipping load when the lift arms are level and bucket fully racked back, and the load is applied at a point on the longitudinal center line of the machine and acting through the bucket volume centroid, this will be the rated load for that machine in its present configuration. As the machine configuration changes, so does the rated load.

The maximum material density would be determined by dividing the payload by the bucket capacity. If the actual material density exceeds the recommended material density, the process should be repeated to select the properly sized bucket.

A similar procedure would be used with the forks and material handling arm to determine maximum recommended lifting capacity and/or required IT model size.

Pallet Fork

The pallet fork will fulfill many material handling needs. A modified Class 3 fork carriage provides visibility to the tines for precision pallet work. This carriage with non-standard spacing accepts many Class 3 lift truck attachments.

Pallet fork rated operating loads are based on the following:

SAE J1197 FEB91: 50% of the full turn static tipping load or the hydraulic/structural limitations.

CEN 474-3 (European standard): 60% of the full static tipping load on rough terrain or the hydraulic/structural limitations. 80% of the full turn static tipping load on firm, level ground or the structural/hydraulic limitation. Other local, regional or international guidelines may also apply.

If operation is on rough ground these criteria may need modification. In this instance, the size and rating of existing equipment should be considered.

Sizing for pallet work generally consists of answering the following questions.

1. What are the average loaded pallet dimensions?
2. Lift Capacity — what capacity is required to lift and move the average pallet load? The maximum pallet load?
3. Lift Height — can the machine reach the top level of the standard pallet stack? What are the maximum reach, lift and height requirements?
4. Maneuverability — can the machine work around the current aisle configuration? In the stacking aisles? Main aisles? Intersecting aisles? Are 90° turns required in any aisle for material placement?
5. Length — what tine length is required to fit the commonly used pallets? (1219 mm [4'0"] tines are standard length for most palletized material.)
6. Any machine height restrictions?
7. Any special fork configurations required?

Lift capacity, lift height, aisle configuration and tine length are the most important considerations in recommending a pallet handling machine.

Example problem:

The following example applies the job analysis method to a work situation.

Sewer & Water Contractor

Sets water lines (152 mm-610 mm [6 in-24 in] iron pipe), sanitary sewer lines (152 mm-457 mm [6 in-18 in] PVC) and storm sewer lines (610 mm-1067 mm [24 in-42 in] concrete pipe) primarily in urban areas ... often-times across or down existing streets.

Materials

- Loam/Clay: 1600 kg/m³ (2700 lb/yd³) loose density
- Bedding (Gravel): 1900 kg/m³ (3200 lb/yd³) loose density
- Water Pipe: 610 mm (24 in) push-on joint ductile iron, 6.1 m (20 ft) sections, 1309 kg (2885 lb) 215 kg/m (144.3 lb/ft) × 6.1 m (20 ft).
- Storm Sewer: 1067 mm (42 in), Wall B, concrete pipe, 1.5 m (5 ft) sections, 1556 kg (3430 lb) 1021 kg/m (686 lb/ft × 5 ft).
- Manhole Boxes: 1361 kg (3000 lb)

WHAT INTEGRATED TOOLCARRIER MODEL SHOULD BE RECOMMENDED?

WHICH ATTACHMENTS?

Work Processes	Integrated Toolcarrier Attachment Possibilities
Bundled PVC and individual concrete/iron pipe-loaded/unloaded (yardsite) and strung along trench	Forks/Material Handling Arm
Unload, handle, set manhole boxes	Material Handling Arm
Excess excavated material truck loaded	Bucket
Bedding material handled/ placed	Bucket
Trench backfilled	Bucket/Blade
Trench compaction	Compactor Wheel
Rough and finish grading	Bucket/Blade
Street cleanup	Bucket/Broom
Pavement removal	Rebar Snips/Asphalt Cutter

Current Equipment

Utilization

- Cat 225. 90%
- Champ CB607 lift truck, 3175 kg (7000 lb) capacity. 15%
- Deere 444 with 1.1 m³ (1.5 yd³) G.P. bucket. 60%
- Rosco D-50 sweeper. one half hour/day
- Rammax 1361 kg (3000 lb) self-propelled trench compactor. 25%

Machine Sizing

1372 mm (54 in) Forks

Operating Load at Full Turn*

Model	kg	lb
926M Standard	2819	6214
930M Standard	3195	7043
938M Standard	3846	8478

- Water pipes: 1309 kg (2885 lb)
 - 926M Standard ... 1 pipe — no problem
 - 930M ... 1 pipe — no problem
 - 938M ... 1 pipe — no problem
- Storm sewer pipes: 1556 kg (3430 lb)
 - 926M Standard ... 1 pipe — no problem
 - 930M ... 1 pipe — no problem
 - 938M ... 1 pipe — no problem

Performance Series Buckets

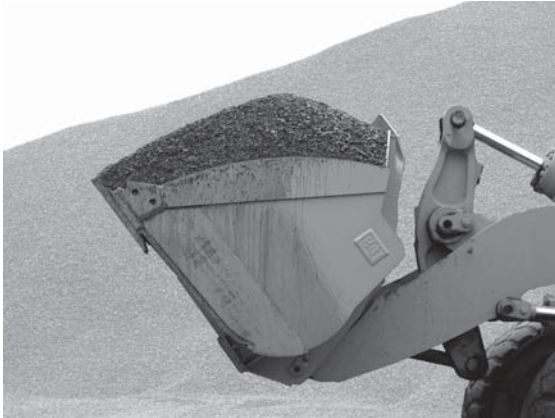

Performance Series Buckets utilize a system-based approach to balance bucket shape against the machine's linkage, weight, lift and tilt capacities. The result is a bucket optimized for performance and productivity, and intended for use in production applications. Performance Series Buckets for Wheel Loaders are designed for use in truck loading, stockpiling and load-and-carry applications. Performance is improved over current buckets in these production applications with materials such as sand, gravel and aggregates.

Loads Easy

Proven design characteristics improve material flow into the bucket and improve material retention during transport. In some situations, the number of passes required to fill a truck is reduced. Performance Series Buckets are designed for optimum performance on the machine. Profile changes (over current buckets) improve loadability and make Performance Series Buckets machine-specific.

Fuel Efficient

Performance Series Buckets have a longer floor — easily digging through the pile. Less time in the pile equals less fuel consumed.

Higher Fill Factors

When comparing buckets of the same rated capacity, Performance Series Buckets have higher fill factors — up to 115%.

Move More Material with the Same Rated Capacity

More material can be moved with a Performance Series Bucket compared to a same-size rated capacity current bucket. Likewise, a smaller Performance Series Bucket can be utilized to move the same amount of material as a larger rated capacity current bucket.

Carries More

Productive

Bucket shape and strike plane angle are designed for material retention and consistent load sizes. More material loads into the bucket and is carried all the way to the truck, hopper or stockpile.

A spill guard diverts overflow away from hinge pins, lift arms, hydraulic cylinders and tilt sensors helping to protect these areas of the machine.

Bucket Specifications

Performance Series Buckets are designed to bring optimum performance to a specific machine. Profile changes over current buckets allow higher fill factors and increased production.

Incompatibility on the 950H and 962H

The recent linkage change on the 950K and 962K has created some incompatibility issues with the Fusion Performance Series Buckets. Because the bucket shape has been optimized for the machine linkage, Fusion Performance Series Buckets designed for use on the 950K and 962K will experience interference with the linkage on the 950H and 962H. For this reason 950K and 962K Performance Series Buckets should NOT be used on the 950H and 962H machines.

Incompatibility on the 966H/K/M

Because 972H/K/M Performance Series Buckets are designed specifically for performance on the 972H/K/M — their shape brings some incompatibilities with the 966H/K/M machine. These buckets can be pinned on to the 966H, but will experience interference with machine linkage in the rack back position. For this reason, 972H/K/M Performance Series Buckets should **not** be used on 966H/K/M machines. This is different than current General Purpose Buckets.

Certain Bucket Sizes Require Additional Counterweight

Compared to a current bucket of the same rated capacity, Performance Series Buckets will move more material. To maintain appropriate machine stability, 980H machines utilizing the two larger Performance Series Buckets must be equipped with the aggregate loader counterweight. This is required for machine stability based on the bucket size/fill factor combination.

Compatible with G and G II Machines

Performance Series Buckets for 988-size machines are compatible with standard and high lift linkages on G and G II Series machines.

Medium Wheel Loader Aggregate Handler

Aggregate packages are specialized offerings for specific loose aggregate rehandling applications, such as truck loading, hopper charging, stockpiling, and load and carry. Rehandling loose aggregate is less stressful on the machine, therefore payloads can be increased above other applications by installing larger buckets, counterweights and a scale system such as the Cat Production Measurement system. To do so, the Cat aggregate packages require some prerequisites in terms of correct application, machine configuration and conformance to Caterpillar payload policy. Misapplication of Aggregate Handlers may result in significant reliability and durability risk.

Material Handling Arm (MHA)

The rated load for the MHA is 50% of the full turn static tipping load in each position or hydraulic or structural limitations. Manually extendable telescopic sections enable maximum lifting capacity at the full retracted position, and maximum lift height and reach in the fully extended position.

Operating Load at Full Turn

Model	Retracted	Mid	Extended
910K	1153 kg 2540 lb	901 kg 1986 lb	741 kg 1634 lb
914K	1430 kg 3151 lb	1122 kg 2472 lb	925 kg 2037 lb
926M Standard	1928 kg 4250 lb	1635 kg 3605 lb	1420 kg 3130 lb
930M Standard	2182 kg 4811 lb	1851 kg 4081 lb	1607 kg 3543 lb
938M Standard	2637 kg 5814 lb	2241 kg 4940 lb	1948 kg 4294 lb

Storm sewer pipes:

1556 kg (3430 lb)

910K ... no

914K ... no

926M ... yes in retracted and mid

930M ... yes in retracted, mid, and extended

938M ... yes in retracted, mid, and extended

Manhole boxes:

1361 kg (3000 lb)

910K ... no

914K ... yes in retracted

926M ... yes in retracted and mid

930M ... yes in retracted, mid, and extended

938M ... yes in retracted, mid, and extended

Buckets

All general purpose buckets are interchangeable on 926M-938M due to common attachment points on the quick couplers. Bucket selection will depend on the material density in your application. Offering multiple sized buckets allows the user the flexibility to closely match material density and bucket size with machine capability. Equipping a machine with too large a bucket will result in unacceptable stability — too small a bucket may provide inadequate tire coverage.

Bucket 1780 kg/m³ (3000 lb/yd³) ... 100% fill factor

Model	Interface	Bucket Type	Width Range		Capacity Range		Weight Range		GET
			mm	in	m ³	yd ³	kg	lb	
926M	Fusion	General Purpose Performance Series	2550-2750	100-108	1.9-2.9	2.5-3.8	775-1042	1705-2292	J250/BOCE
		Light Material	2750	108	3.5-4.2	4.5-5.5	1161-1297	2554-2853	J250/BOCE
		Side Dump	3105	122	1.9	2.5	1653	3644	BOCE Included
		High Dump	2550-3060	100-120	3.0-4.1	3.9-5.4	1710-2041	3770-4500	BOCE Included
		Grapple	2697	106	2.7-2.9	3.5-3.8	1632-1673	3598-3688	J250/BOCE
		Waste	3059	120	3.6-3.8	4.7-5.0	1416-1474	3122-3250	BOCE Included
		Woodchip	3330	131	4.9-5.3	6.4-6.9	1717-1775	3785-3913	BOCE Included
		Grading	2700	106	1.9	2.5	1233	2716	BOCE Included
	Sand & Gravel	2750	108	2.5-3.2	3.2-4.1	1011-1127	2228-2485	J250/BOCE	
	ISO	High Dump	2528-3032	100-120	3.0-4.1	3.9-5.4	1669-2088	3680-4594	BOCE
	Pin On	General Purpose Performance Series	2550	100	1.9-2.5	2.5-3.2	812-979	1786-2154	J250/BOCE
		Light Material	2750	108	3.1-4.2	4.0-5.5	1096-1315	2416-2893	J250/BOCE
		High Dump	2550-3060	100-120	3.0-4.1	4.0-5.4	1742-2067	3840-4557	BOCE Included
		Doze	2743	108	4.2	5.5	1506	3321	BOCE
		Load & Carry	2743	108	4.6	6.0	1528	3369	BOCE
Sand & Gravel		2750	108	2.5-3.2	3.2-4.2	1026-1279	2262-2820	J250/BOCE	
930M	Fusion	General Purpose Performance Series	2550-2750	100-108	1.9-2.9	2.5-3.8	775-1042	1705-2292	J250/BOCE
		Light Material	2750	108	3.1-4.2	4.0-5.5	1075-1297	2370-2853	J250/BOCE
		Side Dump	3105	122	1.9	2.5	1653	3644	BOCE Included
		High Dump	2550-3060	100-120	3.0-5.0	3.9-6.5	1710-2123	3770-4680	BOCE Included
		Grapple	2697	106	2.7-2.9	3.5-3.8	1632-1673	3598-3688	J250/BOCE
		Waste	3059	120	3.6-3.8	4.7-5.0	1416-1474	3122-3250	BOCE Included
		Woodchip	3330	131	4.9-5.3	6.4-6.9	1717-1775	3785-3913	BOCE Included
		Grading	2700	106	1.9	2.5	1233	2716	BOCE Included
	Sand & Gravel	2750	108	2.5-3.2	3.2-4.1	1011-1127	2228-2485	J250/BOCE	
	ISO	High Dump	2528-3032	100-120	3.0-5.0	3.9-6.5	1669-2187	3680-4833	BOCE
	Pin On	General Purpose Performance Series	2550	100	1.9-2.5	2.5-3.2	812-979	1786-2154	J250/BOCE
		Light Material	2750	108	3.1-5.0	4.0-6.5	1096-1383	2416-3043	J250/BOCE
		High Dump	2550-3060	100-120	3.0-5.0	4.0-6.5	1742-2149	3840-4738	BOCE Included
		Doze	2743	108	4.2	5.5	1506	3321	BOCE
		Load & Carry	2743	108	4.6	6.0	1528	3369	BOCE
Sand & Gravel		2750	108	2.5-3.2	3.2-4.2	1026-1279	2262-2820	J250/BOCE	

Model	Interface	Bucket Type	Width Range		Capacity Range		Weight Range		GET
			mm	in	m ³	yd ³	kg	lb	
938M	Fusion	General Purpose Performance Series	2550-2750	100-108	1.9-2.9	2.5-3.8	775-1042	1705-2292	J250/BOCE
		Light Material Side Dump	2750	108	3.1-5.0	4.0-6.5	1075-1360	2370-2992	J250/BOCE
		High Dump	3105	122	1.9	2.5	1653	3644	BOCE Included
			2550-3060	100-120	3.0-5.0	3.9-6.5	1710-2123	3770-4680	BOCE Included
		Grapple	2697	106	2.7-2.9	3.5-3.8	1632-1673	3598-3688	J250/BOCE
		Waste	3059	120	4.0	5.2	1547	3410	BOCE Included
		Woodchip	3330	131	5.5	7.2	1795	3957	BOCE Included
		Grading	2700	106	1.9	2.5	1233	2716	BOCE Included
	Sand & Gravel	2750	108	2.5-3.2	3.2-4.1	1011-1127	2228-2485	J250/BOCE	
	ISO	High Dump	2528-3032	100-120	3.0-5.0	3.9-6.5	1669-2187	3680-4833	BOCE
	Pin On	General Purpose Performance Series	2550-2750	100-108	2.5-2.9	3.2-3.8	979-1059	2154-2330	J250/BOCE
		Light Material High Dump	2750	108	3.5-5.0	4.5-6.5	1178-1378	2596-3038	BOCE Included
		Doze	3060	120	4.1-5.0	5.4-6.5	2065-2147	4553-4733	BOCE Included
Load & Carry		2927	115	4.6	6.0	1854	4088	BOCE	
Sand & Gravel		2927	115	5.2	6.75	1927	4249	BOCE	
950M 962M 950K 962K	Fusion	General Purpose Performance Series	2894	114	2.7-3.8	3.5-5.0	1367-1633	3014-3600	K80/BOCE
		Material Handling Performance Series	2894	114	2.7-3.8	3.5-5.0	1373-1650	3027-3638	K80/BOCE
		Multi-Purpose Side Dump	2943	116	2.9	3.75	2087	4601	BOCE Included
		High Dump	3220	127	2.9	3.75	2348	5177	BOCE Included
		Grapple	2910	115	4.6-6.1	6.0-8.0	2672-2784	5891-6139	BOCE Included
		Waste	3059	120	4.6	6.0	2824	6226	BOCE Included
		Woodchip	3059	120	5.2-6.1	6.75-8.0	2115-2285	4663-5038	BOCE Included
	Pin On	General Purpose Performance Series	3330	131	9.2-9.9	12.0-13.0	2371-2466	5227-5437	BOCE Included
		Material Handling Performance Series	2894	114	2.7-3.8	3.5-5.0	1472-1778	3245-3920	K80/BOCE
		Rock Performance Series	2894	114	2.7-3.8	3.5-5.0	1495-1787	3296-3940	K80/BOCE
		Multi-Purpose Side Dump	2969	117	2.9-3.2	3.75-4.25	1992-2070	4711-4893	K90
		High Dump	2943	116	2.9	3.75	2099	4628	BOCE Included
		Grapple	3226	127	2.9	3.75	2455	5413	BOCE Included
	High Dump	2910	115	4.6-6.1	6.0-8.0	2697-2812	5947-6201	BOCE Included	
	Waste	3059	120	4.6	6.0	2925	6449	BOCE Included	
	Woodchip	3059	120	5.2-6.1	6.75-8.0	2250-2425	4960-5346	BOCE Included	
	Doze	3330	131	9.2-9.9	12.0-13.0	2418-2516	5331-5547	BOCE Included	
	Load & Carry	3059	121	5.2	6.75	2273	5012	BOCE	
		3059	121	6.1	8.0	2604	5742	BOCE	

Model	Interface	Bucket Type	Width Range		Capacity Range		Weight Range		GET
			mm	in	m ³	yd ³	kg	lb	
966M 966K	Fusion	General Purpose Performance Series	3201	126	3.8-4.6	5.0-6.0	1965-2143	4332-4721	K90/BOCE
		Material Handling Performance Series	3201	126	4.0-4.8	5.2-6.3	2068-2254	4559-4969	K90/BOCE
		Coal Performance Series	3447	136	7.1	9.25	2865	6316	BOCE Included
		Rock Performance Series	3255	128	3.4	4.5	2084	4595	K90
		Multi-Purpose	3220	127	3.1	4.0	2785	6140	BOCE Included
		Side Dump	3677	145	3.6	4.75	2832	6243	BOCE Included
		High Dump	3059	120	5.4	7.0	2862	6310	BOCE Included
		Grapple	3048	120	3.8	5.0	4380	9656	K90
		Waste	3323	131	6.5	8.5	2569	5664	BOCE Included
	Woodchip	3943	155	9.9	13.0	2543	5606	BOCE Included	
	Pin On	General Purpose Performance Series	3201	126	3.8-4.6	5.0-6.0	2112-2260	4656-4982	K90/BOCE
		Material Handling Performance Series	3201	126	4.0-4.8	5.25-6.25	2173-2350	4791-5181	K90/BOCE
		Coal Performance Series	3447	136	7.1	9.25	2795	6162	BOCE Included
		Rock Performance Series	3255	128	3.4	4.5	2362	5207	K90
		Heavy Duty Rock	3251	128	3.6-4.0	4.75-5.25	2371-2751	5227-6065	J350/K90
		Multi-Purpose	3226	127	3.1	4.0	2721	5999	K90
		Side Dump	3677	145	3.6	4.75	2858	6301	BOCE Included
		Waste	3357	132	6.5	8.5	2925	6449	BOCE Included
		Woodchip	3327-3937	131-155	8.0-9.9	10.5-13.0	2474-2543	5455-5542	BOCE Included
Doze Load & Carry		3357	132	6.5	8.5	3104	6844	BOCE Included	
								BOCE Included	

Model	Interface	Bucket Type	Width Range		Capacity Range		Weight Range		GET		
			mm	in	m ³	yd ³	kg	lb			
972M 972K	Fusion	General Purpose Performance Series	3201	126	4.2-5.0	5.5-6.5	2026-2233	4467-4923	K90/BOCE		
		Material Handling Performance Series	3201	126	5.2	6.75	2274	5013	K90/BOCE		
		Coal Performance Series	3447	136	7.1	9.25	3199	7053	BOCE Included		
		Rock Performance Series	3255	128	3.6	4.75	2079	4583	K90		
		Multi-Purpose	3220	127	3.1	4.0	2785	6140	BOCE Included		
		Side Dump	3677	145	3.6	4.75	2832	6243	BOCE Included		
		High Dump	3059	120	5.4	7.0	2862	6310	BOCE Included		
		Grapple	3048	120	3.8	5.0	4380	9656	K90		
		Waste	3323	131	6.5	8.5	2569	5664	BOCE Included		
		Woodchip	3943	155	9.9	13.0	2543	5606	BOCE Included		
		Doze	3357	132	6.5	8.5	3086	6805	BOCE Included		
		Load & Carry	3357	132	7.5	9.75	3311	7301	BOCE Included		
		Pin On		General Purpose Performance Series	3193	126	4.2-5.0	5.5-6.5	2214-2383	4881-5254	K90/BOCE
				Material Handling Performance Series	3193	126	4.6-5.2	6.0-6.75	2269-2389	5002-5276	K90/BOCE
Coal Performance Series	3447			136	7.1	9.25	3203	7061	BOCE Included		
Rock Performance Series	3255			128	3.6-4.0	4.75-5.25	2250-2397	4960-5284	K90		
Heavy Duty Rock	3251			128	3.6-4.0	4.75-5.25	2371-2751	5227-6065	J350/K90		
Multi-Purpose	3226			127	3.1	4.0	2721	5999	K90		
Side Dump	3677			145	3.6	4.75	2858	6301	BOCE Included		
Waste	3357			132	6.5	8.5	2925	6449	BOCE Included		
Woodchip	3327-3937			131-155	8.0-9.9	10.5-13.0	2474-2514	5455-5542	BOCE Included		
Slag	3250			128	3.4	4.5	4145	9138	K100		
Doze	3357			132	6.5	8.5	3104	6844	BOCE Included		
Load & Carry	3357	132	7.5	9.75	3311	7301	BOCE Included				

Model	Interface	Bucket Type	Width Range		Capacity Range		Weight Range		GET
			mm	in	m ³	yd ³	kg	lb	
980M 980K	Pin On	General Purpose Performance Series	3405	134	5.4-6.0	7.0-7.85	2674-2853	5895-6290	K90/BOCE
		Material Handling Performance Series	3405	134	5.7	7.5	2882	6354	K90/BOCE
		Coal Performance Series	3638	143	8.2	10.75	3663	8075	BOCE Included
		Rock Performance Series	3495	138	4.4	5.75	2925	6448	K90
		Heavy Duty Quarry Rock	3505-3568	138-140	4.4-4.6	5.75-6.0	3306-3686	7288-8125	BOCE Included
		Waste	3886	153	9.8	12.75	3908	8615	BOCE Included
		Woodchip	4166	164	11.5	15.0	3887	8570	BOCE Included
		Doze	3882	153	13.0	9.9	4210	9283	BOCE Included
		Load & Carry	3882	153	14.0	10.7	4438	9786	BOCE Included
		Slag	3394	134	3.8	5.0	5302	11,689	K130
982M	Pin On	General Purpose Performance Series	3568	141	5.8-6.4	7.5-8.25	3254-3451	7174-7608	K100
		General Purpose Abrasion Performance Series	3568	141	6.4-8.2	8.25-10.75	3406-3829	7509-8442	K100
		Heavy Duty General Purpose Performance Series	3608	142	6.1-7.5	8.0-9.75	3862-4239	8514-9345	K100
		Material Handling Performance Series	3568	141	6.40	8.25	3515	7749	K100
		Heavy Duty Material Handling Performance Series	3608	142	6.4-7.0	8.25-9.25	4204-4407	9270-9717	K100
		Coal Performance Series	3638	143	8.80	11.50	4016	8854	BOCE Included
		Rock Performance Series	3674	144	4.9-5.4	6.5-7.0	3759-3845	8286-8477	K100
		Heavy Duty Quarry Rock Performance Series	3674	144	4.9-5.8	6.5-7.5	4158-4510	9167-9943	K100
		Waste Handling	3882	153	10.20	13.25	4895	10,792	BOCE Included
		Woodchip	4174	164	12.00	15.75	4680	10,318	BOCE Included

Model	Interface	Bucket Type	Width Range		Capacity Range		Weight Range		GET
			mm	in	m ³	yd ³	kg	lb	
986H	Pin On	General Purpose Performance Series	3695	145	6.1-7.7	8.0-10.0	3648-4065	8042-8962	K110
		Rock Performance Series	3772	149	5.4-6.1	7.0-8.0	3726-3941	8214-8688	K110
		Heavy Duty Rock Performance Series	4014	158	5.4	7.0	5061	11,158	K130
		Extreme Duty Rock	4146	163	5.0	6.5	5195	12,050	K130
		Serrated Edge Rock	3812	150	6.1	8.0	4232	9330	N/A
		Coal	3692	145	10.0	13.5	5195	11,453	BOCE Included
988K	Pin On	General Purpose Performance Series	3855	152	6.9-8.4	9.0-11.0	4539-4994	10,007-11,010	K110
		Rock Performance Series	4020	158	6.4-7.7	8.3-10.0	4880-5263	10,759-11,603	K130
		Heavy Duty Rock Performance Series	4080	161	6.4	8.3	6360	14,021	K130
		Heavy Duty Granite Performance Series	3986	157	6.4	8.3	7433	16,385	K130
		Serrated Edge Rock	3968	156	6.4-6.9	8.3-9.0	5455-5634	12,026-12,421	N/A
		Iron Ore	3922	154	4.7	6.2	5771	12,723	K130
		Coal	4120	162	11.5-13.0	15.0-17.0	6023-6435	13,278-14,186	BOCE Included
		Slag	3900-4032	154-159	5.4-6.4	7.0-8.3	7633-8454	16,828-18,638	J600/Serrated Edge

N/A = Not Applicable

Model	Interface	Bucket Type	Width Range		Capacity Range		Weight Range		GET
			mm	in	m ³	yd ³	kg	lb	
990K	Pin On	Rock Performance Series	4610	182	8.6-10.0	11.25-13.0	7247-7497	15,977-16,528	K130
		Heavy Duty Rock Performance Series	4670	184	8.6	11.25	8980	19,798	K130
		Heavy Duty Granite Performance Series	4634	182	8.6	11.25	12 055	26,520	K150
		Slag	4450-4500	175-177	8.5-9.2	11.2-12.0	9149-9613	20,127-21,149	Weld-on edge included
		Coal	4370	172	13.4	17.5	7460	16,410	BOCE Included
		Iron Ore	4450	175	7.0	9.2	8525	18,750	K150
		Serrated Edge Rock	4610	182	9.5	12.4	8140	17,910	N/A
992K	Pin On	Rock	4824-4884	190-192	10.7-12.2	14.0-16.0	9382-10 574	20,684-23,262	K150/K170
		Heavy Duty Rock	5068	200	10.7	14.0	11 560	25,485	K170
		High Abrasion Rock	5068	200	10.7	14.0	11 927	26,295	K150
		Heavy Duty Granite	5165	203	10.7	14.0	13 720	30,247	K150
		Coal	6170	243	19.0	25.0	12 504	27,506	BOCE Included
		Iron Ore	4900	193	9.0	11.8	11 172	24,577	K150
		Serrated Edge Rock	4824	190	12.3	16.0	10 282	22,620	N/A
993K	Pin On	Rock	5068	200	12.2-14.5	16.0-19.0	12 864-14 209	28,301-31,260	K170
		High Abrasion Rock	5160	203	12.2-13.0	16.0-17.0	15 205-15 456	33,451-34,004	K170
		Heavy Duty Granite	5160	203	13.0	17.0	17 418	38,320	K170
		Coal	6300	248	23.0	31.0	17 673	38,880	K170
		Iron Ore	5160	203	10.0	13.0	14 063	30,940	K170
		Serrated Edge Rock	5080	200	15.0	19.5	13 915	30,615	N/A
994K	Pin On	Rock	6223	245	19.1-24.5	25-32	19 205-21 293	42,340-46,942	Spade edge*
		Heavy Duty Rock	6240	246	19.1-21.4	25-28	20 699-21 303	45,633-46,966	Spade edge*
		Coal	6964	274	32.1-39.8	42-52	20 862-22 773	45,992-50,206	Straight edge*
		Iron Ore	6240	246	17.2	22.5	19 518	43,029	Spade edge*

*With teeth and segments.
N/A = Not Applicable

Model	Interface	Bucket Type	Width Range		Capacity Range		Weight Range		GET
			mm	in	m ³	yd ³	kg	lb	
926M 924K	Fusion	General Purpose	2550-2750	100-108	1.9-2.9	2.5-3.8	775-1042	1705-2292	J250/BOCE
		Light Material	2750	108	3.5-4.2	4.5-5.5	1161-1297	2554-2853	BOCE
		High Dump	2550-3060	100-120	3.0-4.1	3.9-5.4	1710-2041	3770-4500	BOCE
		Sand & Gravel	2750	108	2.5-3.2	3.2-4.1	1011-1127	2228-2485	J250/BOCE
	Pin On	General Purpose	2550	100	1.9-2.5	2.5-3.2	812-979	1786-2154	J250/BOCE
		Light Material	2750	108	3.1-4.2	4.0-5.5	1096-1315	2416-2893	BOCE
		High Dump	2550-3060	100-120	3.0-4.1	4.0-5.4	1742-2067	3840-4557	BOCE
		Sand & Gravel	2750	108	2.5-3.2	3.2-4.2	1026-1279	2262-2820	J250/BOCE
930M 930K	Fusion	General Purpose	2550-2750	100-108	1.9-2.9	2.5-3.8	775-1042	1705-2292	J250/BOCE
		Light Material	2750	108	3.1-4.2	4.0-5.5	1075-1297	2370-2853	BOCE
		High Dump	2550-3060	100-120	3.0-5.0	3.9-6.5	1710-2123	3770-4680	BOCE
		Sand & Gravel	2750	108	2.5-3.2	3.2-4.1	1011-1127	2228-2485	J250/BOCE
	Pin On	General Purpose	2550	100	1.9-2.5	2.5-3.2	812-979	1786-2154	J250/BOCE
		Light Material	2750	108	3.1-5.0	4.0-6.5	1096-1383	2416-3043	BOCE
		High Dump	2550-3060	100-120	3.0-5.0	4.0-6.5	1742-2149	3840-4738	BOCE
		Sand & Gravel	2750	108	2.5-3.2	3.2-4.2	1026-1279	2262-2820	J250/BOCE
938M 938K	Fusion	General Purpose	2550-2750	100-108	1.9-2.9	2.5-3.8	775-1042	1705-2292	J250/BOCE
		Light Material	2750	108	3.1-5.0	4.0-6.5	1075-1360	2370-2992	BOCE
		High Dump	2550-3060	100-120	3.0-5.0	3.9-6.5	1710-2123	3770-4680	BOCE
		Sand & Gravel	2750	108	2.5-3.2	3.2-4.1	1011-1127	2228-2485	J250/BOCE
	Pin On	General Purpose	2550-2750	100-108	2.5-2.9	3.2-3.8	968-1059	2134-2330	J250/BOCE
		Light Material	2750	108	3.5-5.0	4.5-6.5	1178-1378	2596-3038	BOCE
		High Dump	3060	120	4.1-5.0	5.3-6.5	2065-2147	4553-4733	BOCE
		Sand & Gravel	2750	108	2.7-3.2	3.5-4.2	1108-1279	2443-2820	J250/BOCE

Model	Interface	Bucket Type	Width Range		Capacity Range		Weight Range		GET
			mm	in	m ³	yd ³	kg	lb	
950H 962H	Fusion	General Purpose Performance Series	2894	114	2.9-3.4	3.75-4.5	1534-1610	3382-3549	K80/BOCE
		Material Handling	2894	114	3.6-3.8	4.75-5.0	1701	3750	K80/BOCE
		Coal	3302	130	5.7-5.9	7.5-7.75	1928	4251	BOCE
		Rock	2969	117	2.7-3.25	3.75-4.25	1588-1638	3500-3611	K90
		Multi-Purpose	2943	116	2.9	3.75	2087	4601	BOCE Included
		Side Dump	3220	127	2.9	3.75	2348	5177	BOCE Included
		High Dump	2910	115	4.6-6.1	6.0-8.0	2672-2784	5891	BOCE Included
		Grapple	3059	120	4.6	6.0	2824	6139	K80
	Waste Handling	3059	120	5.2	6.75	2197	4844	BOCE Included	
	Woodchip	3330	131	9.2	12.0	2238	4934	BOCE Included	
	Pin On	General Purpose Performance Series	2894	114	2.5-3.4	3.5-4.75	1419-1636	3128-3607	K80/BOCE
		Material Handling Performance Series	2894	114	3.0-3.8	4.0-5.0	1538-1684	3391-3713	K80/BOCE
		Coal Performance Series	3040-3059	120	4.2-5.2	5.5-6.75	1889-2069	4165-4559	BOCE Included
		Rock Performance Series	2972	117	2.9-3.3	3.75-4.25	1796-1838	3560-4052	K90
		Multi-Purpose	2929	115	2.9	3.75	2014	4440	BOCE Included
Side Dump		3219	127	2.9	3.75	2425	5346	BOCE Included	
Waste Handling		3059	120	5.2	6.75	2541	5602	BOCE Included	
966H	Fusion	General Purpose Performance Series	3201	126	3.6-4.6	4.75-6.0	1965-2143	4332-4724	K90/BOCE
		Material Handling Performance Series	3201	126	3.8-4.8	5.0-6.3	2068-2254	4559-4969	K90/BOCE
		Coal Performance Series	3447	136	6.9-7.1	9.0-9.25	2865	6316	BOCE Included
		Rock Performance Series	3255	128	3.2-3.4	4.25-4.5	2084	4595	K90
	Pin On	General Purpose Performance Series	3201	126	3.6-4.6	4.75-6.0	2112-2260	4656-4982	K90/BOCE
		Material Handling Performance Series	3201	126	3.8-4.8	5.0-6.3	2173-2350	4791-5181	K90/BOCE
		Coal Performance Series	3447	136	6.9-7.1	9.0-9.25	2795	6162	BOCE Included
		Rock Performance Series	3255	128	3.2-3.4	4.25-4.5	2362	5207	K90

Model	Interface	Bucket Type	Width Range		Capacity Range		Weight Range		GET
			mm	in	m ³	yd ³	kg	lb	
972H	Fusion	General Purpose Performance Series	3201	126	4.0-5.0	5.25-6.5	2026-2212	4467-4877	K90/BOCE
		Material Handling Performance Series	3201	126	5.0-5.2	6.5-6.75	2274	5013	K90/BOCE
		Coal Performance Series	3447	136	6.9-7.1	9.0-9.25	3199	7053	BOCE Included
		Rock Performance Series	3225	128	3.4-3.6	4.5-4.75	2079	4583	K90
	Pin On	General Purpose Performance Series	3201	126	4.0-5.0	5.25-6.5	2214-2315	4881-5104	K90/BOCE
		Material Handling Performance Series	3201	126	4.4-5.2	5.75-6.75	2269-2389	5002-5267	K90/BOCE
		Coal Performance Series	3447	136	6.9-7.1	9.0-9.25	3203	7061	BOCE Included
		Rock Performance Series	3255	128	3.4-4.0	4.5-5.25	2250-2397	4960-5284	K90
966H 972H	Fusion	Multi-Purpose	3220	127	2.9-3.1	3.75-4.0	2892	6375	BOCE Included
		Side Dump	3677	145	3.4-3.6	4.5-4.75	2832	6243	BOCE Included
		High Dump	3059	120	5.0-5.4	6.5-7.0	2904	6402	BOCE Included
		Grapple	3048	120	3.2-3.6	4.25-4.75	4380	9656	K90/BOCE
		Waste	3357	132	6.2-6.5	8.1-8.5	2569	5664	BOCE Included
		Woodchip	3937	155	9.6-9.9	12.5-13.0	2543	5606	BOCE Included
	Pin On	Heavy Duty Rock	3251	125	3.4-4.0	4.5-5.25	2425-2949	5346-6501	K90/J350
		Multi-Purpose	3220	127	2.9-3.1	3.75-4.0	2806	6185	BOCE Included
		Side Dump	3677	145	3.4-3.6	4.5-4.75	2836	6252	BOCE Included
		Waste	3357	132	5.7-6.0	7.5-7.85	2837	6255	BOCE Included
		Woodchip	3327-3937	131-155	7.6-9.9	10.0-13.0	2474-2514	5455-5542	BOCE Included
980H	Pin On	General Purpose Performance Series	3405	134	5.0-6.1	6.5-8.0	2572-2726	5670-6010	K100/BOCE
		Material Handling Performance Series	3405	134	5.5-5.7	7.25-7.5	2780	6129	K100/BOCE
		Coal Performance Series	3638	143	7.8-8.2	10.25-10.75	3213	7083	BOCE Included
		Rock Performance Series	3492	137	4.0-4.4	5.25-5.75	2801	6175	K100
		Heavy Duty General Purpose	3450	136	5.4-5.7	7.0-7.5	3439	7582	BOCE
		Heavy Duty Quarry Rock	3505-3568	138-140	4.0-4.6	5.75-6.0	3306-3686	7288-8125	K110
		Slag	3394	134	3.8	5.0	5302	11,689	K130
		Waste — Load & Carry	3882	153	10.7	14.0	4438	9786	BOCE Included
		Waste — Dozing	3882	153	9.9	13.0	4210	9283	BOCE Included
		Woodchip	4166	164	11.5	15.0	3887	8570	BOCE Included

Model	Interface	Bucket Type	Width Range		Capacity Range		Weight Range		GET
			mm	in	m ³	yd ³	kg	lb	
986H	Pin On	General Purpose Performance Series	3695	145	6.1-7.7	8.0-10.0	3648-4065	8042-8962	K110
		Rock Performance Series	3772	149	5.4-6.1	7.0-8.0	3726-3941	8214-8688	K110
		Heavy Duty Rock Performance Series	4014	158	5.4	7.0	5061	11,158	K130
		Extreme Duty Rock	4146	163	5.0	6.5	5195	12,050	K130
		Serrated Edge Rock	3812	150	6.1	8.0	4232	9330	N/A
		Coal	3692	145	10.0	13.5	5195	11,453	BOCE Included
988K	Pin On	General Purpose Performance Series	3855	152	6.9-8.4	9.0-11.0	4539-4994	10,007-11,010	K110
		Rock Performance Series	4020	158	6.4-7.7	8.3-10.0	4880-5263	10,759-11,603	K130
		Heavy Duty Rock Performance Series	4080	161	6.4	8.3	6360	14,021	K130
		Heavy Duty Granite Performance Series	3986	157	6.4	8.3	7433	16,385	K130
		Serrated Edge Rock	3968	156	6.4-6.9	8.3-9.0	5455-5634	12,026-12,421	N/A
		Iron Ore	3922	154	4.7	6.2	5771	12,723	K130
		Coal	4120	162	11.5-13.0	15.0-17.0	6023-6435	13,278-14,186	BOCE Included
		Slag	3900-4032	154-159	5.4-6.4	7.0-8.3	7633-8454	16,828-18,638	J600/Serrated Edge

N/A = Not Applicable

Wheel Loaders Integrated Toolcarriers

Buckets ● Americas South

Model	Interface	Bucket Type	Width Range		Capacity Range		Weight Range		GET
			mm	in	m ³	yd ³	kg	lb	
990K	Pin On	Rock Performance Series	4610	182	8.60-10.0	11.25-13.0	7247-7497	15,977-16,528	K130
		Heavy Duty Rock Performance Series	4670	184	8.60	11.25	8980	19,798	K130
		Heavy Duty Granite Performance Series	4634	182	8.60	11.25	12 055	26,520	K150
		Iron Ore	4670	184	7.5	9.7	8476	18,686	K150
		Coal	4500	177	15.0	19.5	7986	17,606	BOCE Included
		Slag	4500-4708	177-185	8.6-9.2	11.2-12.0	9664-11 276	21,305-24,859	K130 — Weld-on Edge Included
		Serrated Edge Rock	4610	182	9.5	12.5	8179	18,031	N/A
992K	Pin On	Rock	4824-4884	190-192	10.7-12.2	14.0-16.0	9382-10 574	20,684-23,262	K150/K170
		Heavy Duty Rock	5068	200	10.7	14.0	11 560	25,485	K170
		High Abrasion Rock	5068	200	10.7	14.0	11 927	26,295	K150
		Heavy Duty Granite	5165	203	10.7	14.0	13 720	30,247	K150
		Coal	6170	243	19.0	25.0	12 504	27,506	BOCE Included
		Iron Ore	4900	193	9.0	11.8	11 172	24,577	K150
		Serrated Edge Rock	4824	190	12.3	16.0	10 282	22,620	N/A
993K	Pin On	Rock	5068	200	12.2-14.5	16.0-19.0	12 864-14 209	28,301-31,260	K170
		High Abrasion Rock	5160	203	12.2-13.0	16.0-17.0	15 205-15 456	33,451-34,004	K170
		Heavy Duty Granite	5160	203	13.0	17.0	17 418	38,320	K170
		Coal	6300	248	23.0	31.0	17 673	38,880	K170
		Iron Ore	5160	203	10.0	13.0	14 063	30,940	K170
		Serrated Edge Rock	5080	200	15.0	19.5	13 915	30,615	N/A
994K	Pin On	Rock	6223	245	19.1-24.5	25-32	19 205-21 293	42,340-46,942	Spade edge*
		Heavy Duty Rock	6240	246	19.1-21.4	25-28	20 699-21 303	45,633-46,966	Spade edge*
		Coal	6964	274	32.1-39.8	42-52	20 862-22 773	45,992-50,206	Straight edge*
		Iron Ore	6240	246	17.2	22.5	19 518	43,029	Spade edge*

*With teeth and segments.
N/A = Not Applicable

Model	Interface	Bucket Type	Width Range		Capacity Range		Weight Range		GET
			mm	in	m ³	yd ³	kg	lb	
926M 924K	Fusion	General Purpose	2550-2750	100-108	1.9-2.9	2.5-3.8	775-1042	1705-2292	J250/BOCE
		Light Material	2750	108	3.5-4.2	4.5-5.5	1161-1297	2554-2853	J250/BOCE
		High Dump	2550-3060	100-120	3.0-4.1	3.9-5.4	1710-2041	3770-4500	BOCE
		Sand & Gravel	2750	108	2.5-3.2	3.2-4.1	1011-1127	2228-2485	J250/BOCE
	ISO	General Purpose	2550-2750	100-108	2.1-2.9	2.7-3.8	792-995	1746-2194	J250/BOCE
		Grading	2600-2900	102-114	1.78-2.01	2.3-2.6	847-922	1867-2033	BOCE
		Light Material	2750	108	3.5-5.0	4.5-6.5	1297-2454	2859-6023	J250/BOCE
		High Dump	2550-3060	100-120	3.0-4.1	3.9-5.4	1669-2088	3680-4594	BOCE
	Pin On	General Purpose	2550	100	1.9-2.5	2.5-3.2	812-979	1786-2154	J250/BOCE
		Light Material	2750	108	3.1-4.2	4.0-5.5	1096-1315	1786-2893	J250/BOCE
		High Dump	2550-3060	100-120	3.0-4.1	4.0-5.4	1742-2067	3840-4557	BOCE
		Sand & Gravel	2750	108	2.5-3.2	3.2-4.2	1026-1279	2262-2820	J250/BOCE
930M 930K	Fusion	General Purpose	2550-2750	100-108	1.9-2.9	2.5-3.8	775-1042	1705-2292	J250/BOCE
		Light Material	2750	108	3.1-4.2	4.0-5.5	1075-1297	2370-2853	J250/BOCE
		High Dump	2550-3060	100-120	3.0-5.0	3.9-6.5	1710-2123	3770-4680	BOCE
		Sand & Gravel	2750	108	2.5-3.2	3.2-4.1	1011-1127	2228-2485	J250/BOCE
	ISO	General Purpose	2550-2750	100-108	2.1-2.9	2.7-3.8	792-995	1746-2194	J250/BOCE
		Grading	2600-2900	102-114	1.78-2.01	2.3-2.6	847-922	1867-2033	BOCE
		Light Material	2750	108	3.5-5.0	4.5-6.5	1297-2454	2859-6023	J250/BOCE
		High Dump	2550-3060	100-120	3.0-5.0	3.9-6.5	1669-2187	3680-4833	BOCE
	Pin On	General Purpose	2550	100	1.9-2.5	2.5-3.2	812-979	1786-2154	J250/BOCE
		Light Material	2750	108	3.1-5.0	4.0-6.5	1096-1383	2416-3043	J250/BOCE
		High Dump	2550-3060	100-120	3.0-5.0	4.0-6.5	1695-2149	3737-4738	BOCE
		Sand & Gravel	2750	108	2.5-3.2	3.2-4.2	1026-1279	2262-2820	J250/BOCE
938M 938K	Fusion	General Purpose	2550-2750	100-108	1.9-2.9	2.5-3.8	775-1042	1705-2292	J250/BOCE
		Light Material	2750	108	3.1-5.0	4.0-6.5	1075-1360	2370-2992	J250/BOCE
		High Dump	2550-3060	100-120	3.0-5.0	3.9-6.5	1710-2123	3770-4680	BOCE
		Sand & Gravel	2750	108	2.5-3.2	3.2-4.1	1011-1127	2228-2485	J250/BOCE
	ISO	General Purpose	2550-2750	100-108	2.1-2.9	2.7-3.8	792-995	1746-2194	J250/BOCE
		Grading	2600-2900	102-114	1.78-2.01	2.3-2.6	847-922	1867-2033	BOCE
		Light Material	2750	108	3.5-5.0	4.5-6.5	1297-2454	2859-6023	J250/BOCE
		High Dump	2550-3060	100-120	3.0-5.0	3.9-6.5	1669-2187	3680-4833	BOCE
		GD Skeleton	2850	112	2.5	3.3	1423	3137	N/A
	Pin On	General Purpose	2550-2750	100-108	2.5-2.8	3.2-3.8	968-1059	2134-2330	J250/BOCE
		Light Material	2750	108	3.5-5.0	4.5-6.5	1178-1378	2596-3038	BOCE
		High Dump	3060	120	4.1-5.0	5.3-6.5	2065-2147	4553-4733	BOCE
Sand & Gravel		2750	108	2.7-3.2	3.5-4.2	1108-1279	2443-2820	J250/BOCE	

N/A = Not Applicable

Wheel Loaders Integrated Toolcarriers

Buckets ● Europe, Africa, Middle East

Model	Interface	Bucket Type	Width Range		Capacity Range		Weight Range		GET
			mm	in	m ³	yd ³	kg	lb	
950K	Fusion	General Purpose Performance Series	2894	114	2.9-3.6	3.79-4.7	1449-1550	3195-3417	K80/BOCE
		Material Handling Performance Series	2904-2994	114-117	3.1-3.4	4.05-4.45	1535-2070	3384-4564	K80/BOCE
	Pin On	General Purpose Performance Series	2894	114	2.9-3.6	3.79-4.7	1556-1683	3430-3710	K80/BOCE
		Material Handling Performance Series	2904-2994	114-117	3.1-3.4	4.05-4.45	1543-2060	3402-4541	K80/BOCE
		Rock Performance Series	2969	117	2.9	3.8	1992	4382	K90
		GD Skeleton	3100	122	3.0	3.9	1713	3777	N/A
HD Skeleton	3150	124	3.3	4.3	1897	4182	N/A		
962K	Fusion	General Purpose Performance Series	2894	114	3.2-3.6	4.18-4.7	1517-1550	3344-3417	K80/BOCE
		Material Handling Performance Series	2904-2994	114-117	3.3-3.8	4.32-4.79	1574-2183	3470-4812	K80/BOCE
	Pin On	General Purpose Performance Series	2894	114	3.2-3.6	4.18-4.7	1647-1683	3631-3710	K80/BOCE
		Material Handling Performance Series	2904-2994	114-117	3.3-3.8	4.32-4.79	1582-2173	3488-4790	K80/BOCE
		Rock Performance Series	2969	117	3.2	4.19	2070	4554	K90
		GD Skeleton	3100	122	3.0	3.9	1713	3777	N/A
HD Skeleton	3150	124	3.3	4.3	1897	4182	N/A		
966K	Fusion	General Purpose Performance Series	3201	126	3.6-4.6	4.75-6.0	1943-2082	4283-4590	K90/BOCE
		Material Handling Performance Series	3201	126	3.8-4.8	5.0-6.3	2068-2254	4559-4969	K90/BOCE
		Rock Performance Series	3252	128	3.2-3.4	4.25-4.5	2084	4595	K90
	Pin On	General Purpose Performance Series	3201	126	3.6-4.6	4.75-6.0	1985-2194	4367-4827	K90/BOCE
		Material Handling Performance Series	3000-3289	118-129	3.8-4.8	5.0-6.3	2100-3084	4620-6785	K90/BOCE
		Rock Performance Series	3252	128	3.2-3.4	4.25-4.5	2175	4785	K90
HD Skeleton	3300	130	3.9	5.1	2421	5337	N/A		

N/A = Not Applicable

Model	Interface	Bucket Type	Width Range		Capacity Range		Weight Range		GET
			mm	in	m ³	yd ³	kg	lb	
972K	Fusion	General Purpose Performance Series	3201	126	4.0-5.0	5.25-6.5	1966-2147	4325-4723	K90/BOCE
		Material Handling Performance Series	3201	126	4.4-5.2	5.72-6.76	1907-2274	4195-5003	K90/BOCE
		Rock Performance Series	3225	128	3.4-3.6	4.5-4.75	2099	4618	K90
	Pin On	General Purpose Performance Series	3201	126	4.0-5.0	5.25-6.5	2089-2281	4596-5018	K90/BOCE
		Material Handling Performance Series	3201-3294	126-130	4.4-5.2	5.75-6.75	2248-3122	4946-6868	K90/BOCE
		Rock Performance Series	3252-3350	128-132	3.4-4.0	4.5-5.25	2209-3039	4860-6686	K90/K100
986H	Pin On	General Purpose Performance Series	3695	145	6.1-7.6	8.0-10.0	3648-4121	8042-9085	K110
		Rock Performance Series	3812	150	5.4-6.1	7.0-8.0	3726-3941	8214-8688	K110
		Heavy Duty Rock Performance Series	4014	158	5.4	7.0	5061	11,158	K130
		Extreme Duty Rock	4146	163	5.0	6.5	5466	12,050	K130
		Serrated Edge Rock	3812	150	6.1	8.0	4232	9330	N/A
		Coal	3692	145	10.3	13.5	5088	11,217	BOCE Included
980K	Pin On	General Purpose Performance Series	3413	134	5.0-6.0	6.5-7.8	2572-2831	5670-6228	K100/BOCE
		Material Handling Performance Series	3413-3580	134-141	5.5-5.7	7.25-7.5	2786-4095	6149-9009	K100/BOCE
		Rock Performance Series	3510-3645	138-144	4.5-5.4	5.85-7.02	3058-4335	6728-9537	K100/K110

N/A = Not Applicable

Model	Interface	Bucket Type	Width		Capacity		GET
			mm	in	m ³	yd ³	
990K	Pin On	Rock	4610	181.5	9.2	12.0	Spade
		Rock	4450	175.2	8.6	11.2	Spade
		Heavy Duty Rock	5409	213.0	8.55	11.2	Spade
		Heavy Duty Granite	4636	182.5	8.6	11.2	Spade
		Iron Ore	4450	175.2	7.03	9.2	Spade
		Serrated Edge	4450	175.2	8.6	11.2	V-Edge
		Serrated Edge	4610	181.5	9.1	11.9	V-Edge
		Serrated Edge	4610	181.5	9.5	12.4	Serrated Spade
		Coal	4500	177.2	8.6	11.2	Straight
		Slag	4450	175.2	9.2	12.0	Serrated Spade
		Slag	4500	177.2	8.6	11.2	Serrated Spade
992G	Pin On	Serrated Edge	4826	190.0	11.5	15.0	V-Serrated
		Serrated Edge	4826	190.0	12.3	16.1	V-Serrated
992K	Pin On	Rock	4824	189.9	10.7	14.0	Spade
		Rock	4824	189.9	11.5	15.0	Spade
		Rock	4824	189.9	12.2	16.0	Spade
		Heavy Duty Rock	5080	200.0	10.7	14.0	Spade
		Heavy Duty Granite	5156	203.0	10.7	14.0	Spade
		Iron Ore	4900	192.9	9	11.8	Spade
		Serrated Edge	4824	189.9	12.3	16.1	V-Serrated
Coal	6170	242.9	18.9	24.7	Straight		
993K	Pin On	Rock	5080	200.0	12.2	16.0	Spade
		Rock	5080	200.0	13	17.0	Spade
		Rock	5080	200.0	13.8	18.0	Spade
		Rock	5080	200.0	14.5	19.0	Spade
		High Abrasion	5160	203.1	12.2	16.0	Spade
		High Abrasion	5160	203.1	13	17.0	Spade
		Heavy Duty Granite	5160	203.1	13	17.0	Spade
		Iron Ore	5160	203.1	10	13.1	Spade
		Serrated Edge	5080	200.0	14.9	19.5	V-Serrated
		Coal	6300	248.0	23.7	31.0	Straight
994K	Pin On	Rock	6223	245	19.1-24.5	25-32	Spade edge*
		Heavy Duty Rock	6240	246	19.1-21.4	25-28	Spade edge*
		Coal	6964	274	32.1-39.8	42-52	Straight edge*
		Iron Ore	6240	246	17.2	22.5	Spade edge*

*With teeth and segments.

- Europe, Africa, Middle East
- High Dump Buckets

Wheel Loaders Integrated Toolcarriers

Model	Capacity		Width		Weight		Dump Clearance				Maximum Material Density			
							Standard Lift		High Lift		Standard Lift		High Lift	
	m ³	yd ³	mm	in	kg	lb	mm	in	mm	in	kg/m ³	lb/yd ³	kg/m ³	lb/yd ³
950H	5.1	6.7	3000	118.1	2662	5869	4543	178.9	5147	202.6	873	1471	867	1461
	7.2	9.4	3200	126.0	3444	7593	4625	182.1	5247	206.6	550	927	552	930
	9.0	11.8	3400	133.9	3847	8481	4496	177.0	5126	201.8	404	681	410	691
950K	5.1	6.7	3000	118.1	2620	5776	4567	179.8	5022	197.7	934	1574	829	1397
	7.2	9.4	3200	126.0	3500	7716	4600	181.1	5100	200.8	550	927	470	792
	9.0	11.8	3400	133.9	3900	8598	4650	183.1	5150	202.8	410	691	350	590
962H	5.1	6.7	3000	118.1	2662	5869	4543	178.9	5147	202.6	995	1677	715	1205
	7.2	9.4	3200	126.0	3444	7593	4625	182.1	5247	206.6	635	1070	434	732
	9.0	11.8	3400	133.9	3847	8481	4496	177.0	5126	201.8	472	796	313	528
962K	5.1	6.7	3000	118.1	2620	5776	4567	179.8	5022	197.7	934	1574	829	1397
	7.2	9.4	3200	126.0	3500	7716	4800	189.0	5100	200.8	600	1011	643	1084
	9.0	11.8	3400	133.9	3900	8598	4850	190.9	5150	202.8	450	758	480	809
966H	6.7	8.8	3200	126.0	3598	7932	4909	193.3	5677	223.5	940	1584	975	1643
	11.5	15.0	3600	141.7	5021	11,069	4950	194.9	5500	216.5	444	748	450	758
966K	6.7	8.8	3200	126.0	3598	7932	4909	193.3	5677	223.5	964	1625	988	1665
	11.5	15.0	3600	141.7	5021	11,069	4950	194.9	5500	216.5	429	723	427	720
972H	6.7	8.8	3200	126.0	3598	7932	5003	197.0	5677	223.5	1076	1814	984	1659
	11.5	15.0	3600	141.7	5021	11,069	5170	203.5	5500	216.5	496	836	435	733
972K	6.7	8.8	3200	126.0	3598	7932	4909	193.3	5677	223.5	964	1625	988	1665
	11.5	15.0	3600	141.7	5021	11,069	5170	203.5	5500	216.5	503	848	446	752

Model	Interface	Bucket Type	Width Range		Capacity Range		Weight Range		GET
			mm	in	m ³	yd ³	kg	lb	
926M 924K	Fusion	General Purpose	2550-2750	100-108	1.9-2.9	2.5-3.8	775-1042	1705-2292	J250/BOCE
		Light Material	2750	108	3.5-4.2	4.5-5.5	1161-1297	2554-2853	BOCE
		Side Dump	3105	122	1.9	2.5	1653	3644	BOCE
		High Dump	2550-3060	100-120	3.0-4.1	3.9-5.4	1710-2041	3770-4500	BOCE
		Grapple	2697	106	2.7-2.9	3.5-3.8	1632-1673	3598-3688	J250/BOCE
		Waste	3059	120	3.6-4.0	4.7-5.2	1416-1547	3122-3410	BOCE
		Woodchip	3330	131	4.9-5.5	6.4-7.2	1717-1795	3785-3957	BOCE
		Grading	2700	106	1.9	2.5	1233	2716	BOCE
		Sand & Gravel	2750	108	2.5-3.2	3.2-4.1	1011-1127	2228-2485	J250/BOCE
	ISO	General Purpose	2550-2750	100-108	2.1-2.9	2.7-3.8	775-997	1705-2193	J250/BOCE
		High Dump	2528-3032	100-120	3.0-4.1	3.9-5.4	1669-2088	3680-4594	BOCE
	Pin On	General Purpose	2550	100	1.9-2.5	2.5-3.2	812-979	1768-2154	J250/BOCE
		Light Material	2750	108	3.1-4.2	4.0-5.5	1096-1315	2416-2893	BOCE
		High Dump	2550-3060	100-120	3.0-4.1	4.0-5.4	1742-2067	3840-4557	BOCE
		Sand & Gravel	2750	108	2.5-3.2	3.2-4.2	1026-1279	2262-2820	J250/BOCE
930M 930K	Fusion	General Purpose	2550-2750	100-108	1.9-2.9	2.5-3.8	775-1042	1705-2292	J250/BOCE
		Light Material	2750	108	3.1-4.2	4.0-5.5	1075-1297	2370-2853	BOCE
		Side Dump	3105	122	1.9	2.5	1653	3644	BOCE
		High Dump	2550-3060	100-120	3.0-5.0	3.9-6.5	1710-2123	3770-4680	BOCE
		Grapple	2697	106	2.7-2.9	3.5-3.8	1632-1673	3598-3688	J250/BOCE
		Waste	3059	120	3.6-4.0	4.7-5.2	1416-1547	3122-3410	BOCE
		Woodchip	3330	131	4.9-5.5	6.4-7.2	1717-1795	3785-3957	BOCE
		Grading	2700	106	1.9	2.5	1233	2716	BOCE
		Sand & Gravel	2750	108	2.5-3.2	3.2-4.1	1011-1127	2228-2485	J250/BOCE
	ISO	General Purpose	2550-2750	100-108	2.1-2.9	2.7-3.8	775-997	1705-2193	J250/BOCE
		High Dump	2528-3032	100-120	3.0-5.0	3.9-6.5	1669-2187	3680-4833	BOCE
	Pin On	General Purpose	2550	100	1.9-2.5	2.5-3.2	812-979	1786-2154	J250/BOCE
		Light Material	2750	108	3.1-5.0	4.0-6.5	1096-1383	2416-3043	BOCE
		High Dump	2550-3060	100-120	3.0-5.0	4.0-6.5	1695-2149	3737-4738	BOCE
		Sand & Gravel	2750	108	2.5-3.2	3.2-4.2	1026-1279	2262-2820	J250/BOCE
938K 938M	Fusion	General Purpose	2550-2750	100-108	1.9-2.5	2.5-3.8	775-1042	1705-2292	J250/BOCE
		Light Material	2750	108	3.1-5.0	4.0-6.5	1075-1360	2370-2992	BOCE
		Side Dump	3105	122	1.9	2.5	1653	3644	BOCE
		High Dump	2550-3060	100-120	3.0-5.0	3.9-6.5	1710-2123	3770-4680	BOCE
		Grapple	2697	106	2.7-2.9	3.5-3.8	1632-1673	3598-3688	J250/BOCE
		Waste	3059	120	3.6-4.0	4.7-5.2	1416-1547	3122-3410	BOCE
		Woodchip	3330	131	4.9-5.5	6.4-7.2	1717-1795	3785-3957	BOCE
		Grading	2700	106	1.9	2.5	1233	2716	BOCE
		Sand & Gravel	2750	108	2.5-3.2	3.2-4.1	1011-1127	2228-2485	J250/BOCE
	ISO	General Purpose	2550-2750	100-108	2.1-2.9	2.7-3.8	775-997	1705-2193	J250/BOCE
		High Dump	2528-3032	100-120	3.0-5.0	3.9-6.5	1669-2187	3680-4833	BOCE
	Pin On	General Purpose	2550-2750	100-108	2.5-2.9	3.2-3.8	968-1059	2134-2330	J250/BOCE
		Light Material	2750	108	3.5-5.0	4.5-6.5	1178-1378	2596-3038	BOCE
		High Dump	3060	120	4.1-5.0	5.4-6.5	2065-2147	4553-4733	BOCE
		Sand & Gravel	2750	108	2.7-3.2	3.5-4.2	1108-1279	2443-2820	J250/BOCE

Model	Interface	Bucket Type	Width		Capacity		Weight		GET
			mm	in	m ³	yd ³	kg	lb	
IT62G	HPL	Material Handling	2921	115	3.1	4.1	1242	2738	K80X8
		Material Handling	2921	115	3.2	4.2	1259	2776	K80X8
		Woodchip	3277	129	5.5	7.2	1493	3291	N/A
950H, 950G, 962H, 926G	Pin On	General Purpose Performance Series	2894	114	3.1	4.1	1507	3322	K80X8
		General Purpose Performance Series	2894	114	3.3	4.3	1550	3417	K80X8
		Material Handling Performance Series	2894	114	3.2	4.2	1538	3391	K80X8
		Material Handling Performance Series	2894	114	3.4	4.4	719	1585	K80X8
		Material Handling Performance Series	2894	114	3.8	5.0	1684	3713	K80X8
		General Purpose	2921	115	3.1	4.0	1483	3269	K80X8
		General Purpose	2921	115	3.4	4.5	1583	3490	K80X8
		Material Handling	2921	115	3.4	4.5	1424	3139	K80X8
		Material Handling	2946	116	4.2	5.5	1725	3803	K80X8
		Material Handling	N/A	N/A	3.3	4.3	1326	2923	K80X8
		Rock	2972	117	2.9	3.8	1550	3417	N/A
		Rock	2972	117	2.9	3.8	1618	3567	N/A
	Woodchip	3327	131	9.2	12.0	2279	5024	N/A	
	HPL	General Purpose	2921	115	3.1	4.1	1479	3261	K80X8
		General Purpose	2921	115	3.2	4.2	1280	2822	K80X8
		General Purpose	2921	115	3.4	4.4	1385	3053	K80X8
		Woodchip	3327	131	9.2	12.0	2349	5179	N/A
	Fusion	General Purpose	2896	114	3.1	4.1	1322	2915	K80X8
		General Purpose	2896	114	3.4	4.4	1408	3104	K80X8
		General Purpose	2896	114	3.8	5.0	1483	3269	K80X8
		Rock	2969	117	3.1	4.1	1588	3501	K90X8
Rock		2969	117	3.3	4.3	1638	3611	K90X8	
Material Handling		2896	114	3.4	4.4	1370	3020	K80X8	
Material Handling		2896	114	3.8	5.0	1447	3190	K80X8	
Coal		3302	130	5.9	7.7	1928	4251	N/A	
Multi-purpose		2946	116	2.87	3.75	2087	4601	N/A	
Side Dump		3226	127	2.87	3.75	2340	5159	N/A	
High Dump		2921	115	4.6	6.0	2657	5858	N/A	
Grapple		2921	115	3.25	4.25	2139	4716	N/A	
Waste		3048	120	5.2	6.8	2163	4769	N/A	
Woodchip		3327	131	9.2	12.0	2121	4676	N/A	

N/A = Not Applicable

Model	Interface	Bucket Type	Width		Capacity		Weight		GET	
			mm	in	m ³	yd ³	kg	lb		
966, 972	Pin On	General Purpose Performance Series	3193	126	4.0	5.2	2164	4771	K90X8	
		General Purpose Performance Series	3193	126	4.2	5.5	2220	4894	K90X8	
		General Purpose Performance Series	3193	126	4.6	6.0	2220	4894	K90X8	
		General Purpose Performance Series	3193	126	4.6	6.0	2303	5077	K90X8	
		General Purpose Performance Series	3201	126	5.0	6.5	2332	5141	K90X8	
		Material Handling Performance Series	3302	130	4.0	5.2	2173	4791	K90X8	
		Material Handling Performance Series	3193	126	4.2	5.5	2108	4647	K90X8	
		Material Handling Performance Series	3193	126	4.6	6.0	2152	4744	K90X8	
		Rock Performance Series	3255	128	3.4	4.4	2362	5207	K90X8	
		Rock Performance Series	3255	128	4.0	5.2	2397	5284	K90X8	
		General Purpose	3150	124	4.0	5.2	1992	4392	K90X8	
		General Purpose	3226	127	5.2	6.8	2141	4720	N/A	
		Material Handling	3302	130	4.0	5.2	2049	4517	K90	
		Material Handling	3311	130	4.7	6.1	2207	4866	K90	
		Material Handling	3200	126	4.9	6.4	2130	4696	N/A	
		Material Handling	3193	126	4.3	5.6	2108	4647	N/A	
		Rock	3252	128	N/A	N/A	2405	5302	K90X8	
		Rock	3252	128	N/A	N/A	2522	5560	J350X8	
		Rock	3252	128	N/A	N/A	2522	5560	K90X8	
		Heavy Duty Rock	3251	128	3.6	4.7	2425	5346	J350	
		Heavy Duty Rock	3252	128	3.6	4.7	2562	5648	K90	
		Heavy Duty Rock	3251	128	4.0	5.2	2949	6501	K90	
		Woodchip	3327	131	8.0	10.46	2474	5454	N/A	
		Woodchip	3937	155	9.9	13.0	2359	5201	N/A	
		Woodchip	3923	154	10.2	13.3	2279	5024	N/A	
		HPL	General Purpose	3023	119	3.8	5.0	1093	2410	K90X8
			General Purpose	3226	127	4.2	5.5	1986	4378	K90X8
			General Purpose	3226	127	4.6	6.0	1900	4189	K90X8
			Woodchip	3328	131	8.0	10.46	2360	5203	N/A
			Woodchip	3937	155	9.9	13.0	2825	6228	N/A

N/A = Not Applicable

Model	Interface	Bucket Type	Width		Capacity		Weight		GET
			mm	in	m ³	yd ³	kg	lb	
966, 972	Fusion	General Purpose	3307	130	3.8	5.0	1730	3814	K90X8
		General Purpose	3307	130	4.2	5.5	1808	3986	K90X8
		General Purpose	3311	130	4.8	6.3	1914	4220	K90X8
		Rock/Spade	3252	128	N/A	N/A	2174	4793	K90X8
		Rock/Spade	3252	128	N/A	N/A	2050	4519	K90X8
		Material Handling	3311	130	4.2	5.5	1850	4079	K90X8
		Material Handling	3311	130	4.6	6.0	1882	4149	K90X8
		Coal	3405	134	6.7	8.8	2271	5007	K90X8
		Coal	3405	134	7.7	10.1	2454	5410	K90X8
		Multi-purpose	3220	127	N/A	N/A	2785	6140	N/A
		Side Dump	3677	145	N/A	N/A	2832	6243	N/A
		High Dump	3059	120	N/A	N/A	2862	6310	N/A
		Grapple	3048	120	N/A	N/A	4380	9656	N/A
		Waste	3323	131	N/A	N/A	2569	5664	N/A
Woodchip	3923	154	9.94	13	2543	5606	N/A		
980H, 980G	Pin On	General Purpose Performance Series	3405	134	5.3	6.9	2572	5670	K100X8
		General Purpose Performance Series	3405	134	5.7	7.5	2677	5902	K100X8
		General Purpose Performance Series	3405	134	7.0	9.2	2726	6010	K100X8
		Material Handling Performance Series	3405	134	5.7	7.5	2780	6129	K100X8
		Rock Performance Series	3510	138	N/A	N/A	3402	7500	K100X8
		Rock Performance Series	3510	138	N/A	N/A	3531	7785	K100X8
		General Purpose	3531	139	4.8	6.3	2340	5159	K100X8
		General Purpose	3531	139	5.2	6.8	2430	5357	K100X8
		General Purpose	3531	139	5.5	7.2	2503	5518	K100X8
		General Purpose	3413	134	N/A	N/A	2580	5688	K100X8
		General Purpose	3531	139	5.2	6.8	2398	5287	K100X8
		General Purpose	3531	139	5.5	7.2	2654	5851	K100X8
		General Purpose-HD	3533	139	5.5	7.2	3167	6982	K100X8
		Material Handling	3531	139	5.7	7.5	2727	6012	K100X8
		Material Handling	3683	145	7.5	9.7	3512	7743	K100X8
		Rock	3480	137	N/A	N/A	2576	5679	J400X8
		Rock	3492	137	N/A	N/A	2754	6072	K100X8
		Rock	3492	137	N/A	N/A	3084	6799	J400X8
		Rock	3492	137	N/A	N/A	3132	6905	K100X8
		Coal	3638	143	N/A	N/A	3622	7985	N/A
	Woodchip	4165	164	N/A	N/A	3996	8810	N/A	
	Pin On	Coal	3800	150	6.5	8.5	4511	9945	K110
		Coal	4120	162	11.5	15.0	5910	13,029	BOCE Included
		Coal	4120	162	13.0	17.0	6325	13,944	BOCE Included
		General Purpose	2695	106	7.0	9.2	4218	9299	K110
		General Purpose	3900	154	7.7	10.1	4770	10,516	BOCE Included
Rock		3835	151	6.4	8.4	4815	10,615	K130	
Rock		4026	159	6.9	9.0	4662	10,278	K110	
Rock		4026	159	7.7	10.1	4600	10,141	K110	

N/A = Not Applicable

Model	Interface	Bucket Type	Width		Capacity		Weight		GET
			mm	in	m ³	yd ³	kg	lb	
990K	Pin On	Rock	4450	175	8.5	11.1	6772	14,930	K130
		Rock	4597	181	9.2	12.0	7038	15,516	K130
		Heavy Duty Rock	4510	178	8.5	11.1	8594	18,947	K130 MAWPs
		Heavy Duty Granite	4620	182	8.5	11.1	9929	21,890	K150 MAWPs
		Slag	4450	175	9.2	12.0	9613	21,193	Serrated
		Slag	4500	177	8.5	11.1	9149	20,170	K130
		Coal	4370	172	13.4	17.5	7460	16,446	BOCE Included
		Slag	4450	175	7.0	9.2	8525	18,794	K150
		Serrated Edge Rock	4610	181	9.5	12.4	8140	17,946	N/A
992K	Pin On	Rock	4824	190	10.7	14.0	9382	20,684	K150
		Rock	4884	192	11.5	15.0	9776	21,552	K170
		Rock	4824	190	11.5	15.0	9557	21,070	K150
		Rock	4824	190	12.2	16.0	10 574	23,312	K170
		Heavy Duty Rock	5068	200	10.7	14.0	11 560	25,485	K170
		High Abrasion Rock	5068	200	10.7	14.0	11 927	26,295	K150
		Heavy Duty Granite	5165	203	10.7	14.0	13 720	30,247	K150
		Coal	6170	243	19.0	24.9	12 504	27,567	BOCE Included
		Iron Ore	4900	193	9.0	11.8	11 172	24,630	K150
Serrated Edge Rock	4824	190	12.3	16.1	10 282	22,668	N/A		
993K	Pin On	Rock	5068	200	12.2	16.0	12 864	28,360	K170
		Rock	5068	200	13.0	17.0	13 380	29,498	K170
		Rock	5068	200	13.8	18.0	14 024	30,918	K170
		Rock	5068	200	14.5	19.0	14 209	31,325	K170
		High Abrasion Rock	5160	203	12.2	16.0	15 205	33,521	K170
		High Abrasion Rock	5160	203	13.0	17.0	15 456	34,075	K170
		Heavy Duty Granite	5160	203	13.0	17.0	17 418	38,400	K170
		Coal	6300	248	23.0	30.1	17 673	38,962	K170
		Iron Ore	5160	203	10.0	13.1	14 063	31,004	K170
Serrated Edge Rock	5080	200	15.0	19.6	13 915	30,677	N/A		
994K	Pin On	Rock	6223	245	19.1-24.5	25-32	19 205- 21 293	42,340- 46,942	Spade edge*
		Heavy Duty Rock	6240	246	19.1-21.4	25-28	20 699- 21 303	45,633- 46,966	Spade edge*
		Coal	6964	274	32.1-39.8	42-52	20 862- 22 773	45,992- 50,206	Straight edge*
		Iron Ore	6240	246	17.2	22.5	19 518	43,029	Spade edge*

*With teeth and segments.
N/A = Not Applicable

Model	Interface	Bucket Type	Width		Capacity		Weight		GET	
			mm	in	m ³	yd ³	kg	lb		
IT62G	HPL	Material Handling	2921	115	3.20	4.2	1259	571	K80X8	
		Woodchip	3277	129	8.40	11.0	1493	677	N/A	
950H, 950G, 962H, 962G	Pin On	General Purpose	2894	114	3.10	4.1	1507	684	K80X8	
		General Purpose	2894	114	3.30	4.3	1550	703	K80X8	
		Material Handling	2894	114	3.20	4.2	1538	698	K80X8	
		Material Handling	2894	114	3.40	4.4	1584	719	K80X8	
		Material Handling	2894	114	3.80	5.0	1684	764	K80X8	
		General Purpose	2997	118	2.70	3.5	1347	611	K80X8	
		General Purpose	2921	115	3.06	4.0	1483	673	K80X8	
		Material Handling	2946	116	5.73	7.5	1878	852	N/A	
		Material Handling	2946	116	4.40	5.8	1905	864	N/A	
		Material Handling	N/A	N/A	3.30	4.3	1326	601	K80X8	
		Waste Handling	3058	120	5.20	6.8	2375	1077	N/A	
		HPL	Woodchip	3327	131	9.20	12.0	2349	1066	N/A
		966, 972	Pin On	General Purpose	3193	126	4.00	5.2	2164	982
General Purpose	3193			126	4.20	5.5	2220	1007	K90X8	
General Purpose	3193			126	4.60	6.0	2220	1007	K90X8	
General Purpose	3193			126	4.60	6.0	2303	1045	K90X8	
General Purpose	3201			126	5.00	6.5	2332	1058	K90X8	
Material Handling	3302			130	4.00	5.2	2173	986	K90X8	
Material Handling	3193			126	4.20	5.5	2108	956	K90X8	
Material Handling	3193			126	4.60	6.0	2152	976	K90X8	
Rock	3255			128	3.40	4.4	2362	1071	K90X8	
Rock	3255			128	4.00	5.2	2397	1087	K90X8	
General Purpose	3150			124	3.80	5.0	2188	992	K90X8	
General Purpose	3150			124	3.60	4.7	1903	863	K90X8	
General Purpose	3150			124	4.00	5.2	1992	904	K90X8	
Material Handling	3454			136	5.73	7.5	2586	1173	N/A	
Material Handling	3429			135	7.26	9.5	2595	1177	N/A	
Rock	3252			128	N/A	N/A	2405	1091	K90X8	
Woodchip	3937			155	9.90	12.9	2359	1070	N/A	
HPL	General Purpose			3023	119	3.82	5.0	1093	496	K90X8
	General Purpose	3226	127	4.21	5.5	1986	901	K90X8		
980H, 980G	Pin On	General Purpose	3405	134	5.30	6.9	2572	1167	K100X8	
		General Purpose	3405	134	5.70	7.5	2677	1214	K100X8	
		General Purpose	3405	134	7.00	9.2	2726	1237	K100X8	
		Material Handling	3405	134	5.70	7.5	2780	1261	K100X8	
		Rock	3510	138	N/A	N/A	3402	1543	K100X8	
		Rock	3510	138	N/A	N/A	3531	1602	K100X8	
		General Purpose	3531	139	5.40	7.1	2430	1102	K100X8	
		General Purpose	3531	139	5.70	7.5	2503	1135	K100X8	
		Rock	3492	137	N/A	N/A	3084	1399	J400X8	
		Coal	3638	143	N/A	N/A	3622	1643	N/A	
		HPL	General Purpose	3454	136	5.00	6.5	2794	1267	K100X8
BH	Block Handler	3658	144	4.50	5.9	3810	1728	K100X8		

N/A = Not Applicable

Model	Interface	Bucket Type	Width		Capacity		Weight		GET
			mm	in	m ³	yd ³	kg	lb	
988K	Pin On	General Purpose Performance Series	3855	152	6.9-8.4	9.0-11.0	4539-4994	10,007-11,010	K110
		Rock Performance Series	4020	158	6.4-7.7	8.3-10.0	4880-5263	10,759-11,603	K130
		Heavy Duty Rock Performance Series	4080	161	6.4	8.3	6360	14,021	K130
		Heavy Duty Granite Performance Series	3986	157	6.4	8.3	7433	16,385	K130
		Serrated Edge Rock	3968	156	6.4-6.9	8.3-9.0	5455-5634	12,026-12,421	N/A
		Iron Ore	3922	154	4.7	6.2	5771	12,723	K130
		Coal	4120	162	11.5-13.0	15.0-17.0	6023-6435	13,728-14,186	BOCE Included
		Slag	3900-4032	154-159	5.4-6.4	7.0-8.3	7633-8454	16,828-18,638	J600/Serrated Edge
990K	Pin On	Rock	4450	175	8.50	11.1	6772	3072	K130
		Rock	4597	181	9.20	12.0	7038	3192	K130
		Heavy Duty Granite	4620	182	8.50	11.1	9929	4504	K150 MAWPs
		Slag	4450	175	9.20	12.0	9613	4360	Serrated Weld-On Edge
		Slag	4500	177	8.50	11.1	9149	4150	K130
992K	Pin On	Rock	4824	190	10.70	14.0	9382	4256	K150
		Rock	4884	192	11.50	15.0	9776	4434	K170
		Rock	4824	190	11.50	15.0	9557	4335	K150
		Rock	4824	190	12.20	16.0	10 574	4796	K170
		Heavy Duty Rock	5068	200	10.70	14.0	11 560	5244	K170
		High Abrasion Rock	5068	200	10.70	14.0	11 927	5410	K150
		Heavy Duty Granite	5165	203	10.70	14.0	13 720	6223	K150
		Serrated Edge Rock	4824	190	12.30	16.1	10 282	4664	N/A
993K	Pin On	Rock	5068	200	12.20	16.0	12 864	5835	K170
		Rock	5068	200	14.50	19.0	14 209	6445	K170
		High Abrasion Rock	5160	203	13.00	17.0	15 456	7011	K170
		Heavy Duty Granite	5160	203	13.00	17.0	17 418	7901	K170
		Coal	6300	248	23.00	30.1	17 673	8016	K170
		Iron Ore	5160	203	10.00	13.1	14 063	6379	K170
994K	Pin On	Rock	6223	245	19.1-24.5	25-32	19 205-21 293	42,340-46,942	Spade edge*
		Heavy Duty Rock	6240	246	19.1-21.4	25-28	20 699-21 303	45,633-46,966	Spade edge*
		Coal	6964	274	32.1-39.8	42-52	20 862-22 773	45,992-50,206	Straight edge*
		Iron Ore	6240	246	17.2	22.5	19 518	43,029	Spade edge*

*With teeth and segments.
N/A = Not Applicable

Model	Interface	Bucket Type	Width		Capacity		Weight		GET		
			mm	in	m ³	yd ³	kg	lb			
IT62G	IT	Woodchip	3277	129	8.40	10.99	1493	3291	N/A		
			950H, 950G, 962H, 962G	Pin On	General Purpose Performance Series	2894	114	3.10	4.05	1507	3322
950H, 950G, 962H, 962G	Pin On	General Purpose Performance Series	2894	114	3.30	4.32	1550	3417	K80X8		
		Material Handling Performance Series	2894	114	3.20	4.19	1538	3391	K80X8		
		Material Handling Performance Series	2894	114	3.40	4.45	1584	3492	K80X8		
		Material Handling Performance Series	2894	114	3.80	4.97	1684	3713	K80X8		
		General Purpose	2997	118	2.70	3.53	1347	2970	K80X8		
		General Purpose	2921	115	3.06	4.00	1483	3269	K80X8		
		Material Handling	2946	116	5.73	7.49	1878	4140	N/A		
		Material Handling	2946	116	4.40	5.75	1905	4200	N/A		
		Material Handling	N/A	3.30	4.32	1326	2923	K80X8			
		Waste Handling	3058	120	5.20	6.80	2375	5236	N/A		
		Rock	2972	117	2.90	3.79	1826	4026	J350X8		
		966G, 972G		General Purpose Performance Series	3193	126	4.00	5.23	2164	4771	K90X8
				General Purpose Performance Series	3193	126	4.20	5.49	2220	4894	K90X8
				General Purpose Performance Series	3193	126	4.60	6.02	2220	4894	K90X8
General Purpose Performance Series	3193			126	4.60	6.02	2303	5077	K90X8		
General Purpose Performance Series	3201			126	5.00	6.54	2332	5141	K90X8		
Material Handling Performance Series	3302			130	4.00	5.23	2173	4791	K90X8		
Material Handling Performance Series	3193			126	4.20	5.49	2108	4647	K90X8		
Material Handling Performance Series	3193			126	4.60	6.02	2152	4744	K90X8		
Rock Performance Series	3255			128	3.40	4.45	2362	5207	K90X8		
Rock Performance Series	3255			128	4.00	5.23	2397	5284	K90X8		
General Purpose	3193			126	4.96	6.49	2125	4685	K90X8		
General Purpose	3150			124	3.60	4.71	1903	4195	K90X8		
General Purpose	3150			124	4.00	5.23	1992	4392	K90X8		
Material Handling	3302			130	4.00	5.23	2049	4517	K90X8		
Material Handling	3311			130	4.70	6.15	2207	4866	K90X8		
Material Handling	3447			136	5.73	7.49	2426	5348	N/A		
Rock	3252			128	—	—	2405	5302	K90X8		
Side Dump	3299			130	3.40	4.45	3855	8499	K80X8		

N/A = Not Applicable

Model	Interface	Bucket Type	Width		Capacity		Weight Range		GET
			mm	in	m ³	yd ³	kg	lb	
980H, 980G	Pin On	General Purpose Performance Series	3405	134	5.30	6.93	2572	5670	K100X8
		General Purpose Performance Series	3405	134	5.70	7.46	2677	5902	K100X8
		General Purpose Performance Series	3405	134	7.00	9.16	2726	6010	K100X8
		Material Handling Performance Series	3405	134	5.70	7.46	2780	6129	K100X8
		Rock Performance Series	3510	138	5.40	7.10	3402	7500	K100X8
		Rock Performance Series	3510	138	5.40	7.10	3531	7785	K100X8
		General Purpose	3531	139	5.40	7.06	2430	5357	K100X8
	HPL	Block Handler	3658	144	4.50	5.89	3810	8400	K100X8
986H	Pin On	Rock	3772	148.5	5.4-6.1	7-8	3692-3907	8139-8693	J460
988K	Pin On	General Purpose Performance Series	3855	152	6.9-8.4	9.0-11.0	4539-4994	10,007-11,010	K110
		Rock Performance Series	4020	158	6.4-7.7	8.3-10.0	4880-5263	10,759-11,603	K130
		Heavy Duty Rock Performance Series	4080	161	6.4	8.3	6360	14,021	K130
		Heavy Duty Granite Performance Series	3986	157	6.4	8.3	7433	16,385	K130
		Serrated Edge Rock	3968	156	6.4-6.9	8.3-9.0	5455-5634	12,026-12,421	N/A
		Iron Ore	3922	154	4.7	6.2	5771	12,723	K130
		Coal	4120	162	11.5-13.0	15.0-17.0	6023-6435	13,728-14,186	BOCE Included
		Slag	3900-4032	154-159	5.4-6.4	7.0-8.3	7633-8454	16,828-18,638	J600/Serrated Edge

N/A = Not Applicable

Model	Interface	Bucket Type	Width		Capacity		Weight Range		GET
			mm	in	m ³	yd ³	kg	lb	
990K	Pin On	Rock	4450	175	8.50	11.12	6772	14,930	K130 K130 K130 MAWPs K150 MAWPs Serrated Weld-On Edge K130
		Rock	4597	181	9.20	12.03	7038	15,516	
		Heavy Duty Rock	4510	178	8.50	11.12	8594	18,947	
		Heavy Duty Granite	4620	182	8.50	11.12	9929	21,890	
		Slag	4450	175	9.20	12.03	9613	21,193	
		Slag	4500	177	8.50	11.12	9149	20,170	
992K	Pin On	Rock	4824	190	10.70	14.00	9382	20,684	K150
		Rock	4884	192	11.50	15.04	9776	21,552	K170
		Rock	4824	190	11.50	15.04	9557	21,070	K150
		Rock	4824	190	12.20	15.96	10 574	23,312	K170
		Heavy Duty Rock	5068	200	10.70	14.00	11 560	25,485	K170
		High Abrasion Rock	5068	200	10.70	14.00	11 927	26,295	K150
		Heavy Duty Granite	5165	203	10.70	14.00	13 720	30,247	K150
		Serrated Edge Rock	4824	190	12.30	16.09	10 282	22,668	N/A
993K	Pin On	Rock	5068	200	12.20	15.96	12 864	28,360	K170
		Rock	5068	200	14.50	18.97	14 209	31,325	K170
		High Abrasion Rock	5160	203	13.00	17.00	15 456	34,075	K170
		Heavy Duty Granite	5160	203	13.00	17.00	17 418	38,400	K170
		Coal	6300	248	23.00	30.08	17 673	38,962	K170
		Iron Ore	5160	203	10.00	13.08	14 063	31,004	K170
994K	Pin On	Rock	6223	245	19.1-24.5	25-32	19 205- 21 293	42,340- 46,942	Spade edge*
		Heavy Duty Rock	6240	246	19.1-21.4	25-28	20 699- 21 303	45,633- 46,966	Spade edge*
		Coal	6964	274	32.1-39.8	42-52	20 862- 22 773	45,992- 50,206	Straight edge*
		Iron Ore	6240	246	17.2	22.5	19 518	43,029	Spade edge*

*With teeth and segments.
N/A = Not Applicable

**906K/M
Vertical Coupler**

Bucket Type	Rated Capacity		Maximum Material Density	
	m ³	yd ³	kg/m ³	lb/yd ³
General Purpose	0.90	1.18	1755	2952
Light Material	1.20	1.57	1208	2032
Multi-Purpose	0.75	0.98	2131	3584

**906K/M
Horizontal Coupler**

Bucket Type	Rated Capacity		Maximum Material Density	
	m ³	yd ³	kg/m ³	lb/yd ³
General Purpose	0.90	1.18	1889	3177
Light Material	1.20	1.57	1271	2138
Multi-Purpose	0.75	0.98	2184	3674

**907K/M
Vertical Coupler**

Bucket Type	Rated Capacity		Maximum Material Density	
	m ³	yd ³	kg/m ³	lb/yd ³
General Purpose	1.00	1.31	1584	2664
Light Material	1.20	1.57	1218	2049
Multi-Purpose	0.75	0.98	2149	3615

**907K/M
Horizontal Coupler**

Bucket Type	Rated Capacity		Maximum Material Density	
	m ³	yd ³	kg/m ³	lb/yd ³
General Purpose	1.00	1.31	1706	2870
Light Material	1.20	1.57	1310	2203
Multi-Purpose	0.75	0.98	2202	3704

**908K/M
Vertical Coupler**

Bucket Type	Rated Capacity		Maximum Material Density	
	m ³	yd ³	kg/m ³	lb/yd ³
General Purpose	1.10	1.44	1549	2605
Light Material	1.50	1.96	1034	1739
Multi-Purpose	0.90	1.18	1929	3245

**908K/M
Horizontal Coupler**

Bucket Type	Rated Capacity		Maximum Material Density	
	m ³	yd ³	kg/m ³	lb/yd ³
General Purpose	1.10	1.44	1658	2789
Light Material	1.50	1.96	1106	1860
Multi-Purpose	0.90	1.18	1967	3309

910K — Standard Lift

Bucket Fill Factor		kg/m ³	1150	1225	1300	1375	1450	1525	1600	1675	1750	1825	1900		
		lb/yd ³	1938	2064	2191	2317	2443	2570	2696	2822	2949	3075	3202		
		m ³													
		yd ³													
General Purpose	Pin On	1.3	1.7					114%	109%	104%	99%	95%			
		1.3	1.7					114%	109%	104%	99%	95%			
		1.5	2.0	114%		108%	102%	97%							
	IT	1.2	1.6						111%		106%	102%	98%		
		1.3	1.7					112%	107%	102%	98%				
		1.4	1.8	114%		108%	103%	98%							
	ISO	1.5	2.0	112%		106%	100%	95%							
		1.2	1.6						113%	108%	103%	99%	95%		
		1.4	1.8	111%		105%	100%	96%							

23

Material density and fill factor are key variables when choosing the appropriate size of the bucket. The long floor and open throat design of the Performance Series Buckets along with the aggressive rack angles of the Cat Optimized Z-bar Loader will demonstrate fill factors greater than 100% ISO rated. Refer to the **Fill Factors** table for expected fill factor per material density and **Bucket Selection** table for bucket sizing.

910K — Standard Lift Fill Factors

Materials	Density	Fill %
Earth and rock	~ 1800 kg/m ³ ~ 3033 lb/yd ³	~ 115%
Sand & gravel	~ 1700 kg/m ³ ~ 2865 lb/yd ³	~ 115%
Aggregates	~ 1600 kg/m ³ ~ 2696 lb/yd ³	~ 105%
Bulk grains	~ 750 kg/m ³ ~ 1264 lb/yd ³	~ 100%
Woodchips	~ 500 kg/m ³ ~ 843 lb/yd ³	~ 100%

910K — High Lift

Bucket Fill Factor		kg/m ³	1075	1150	1225	1300	1375	1450	1525	1600	1675	1750	1825		
		lb/yd ³	1811	1938	2064	2191	2317	2443	2570	2696	2822	2949	3075		
		m ³													
		yd ³													
General Purpose	Pin On	1.3	1.7					111%	106%	101%	96%				
		1.3	1.7					111%	106%	101%	96%				
		1.5	2.0			113%	106%	100%	95%						
	IT	1.2	1.6							113%	107%	103%	98%	94%	
		1.3	1.7							109%	104%	99%	95%		
		1.4	1.8			112%	106%	100%	95%						
	ISO	1.5	2.0			110%	104%	98%							
		1.2	1.6							110%	105%	100%	96%		
			1.4	1.8			109%	103%	98%						

Material density and fill factor are key variables when choosing the appropriate size of the bucket. The long floor and open throat design of the Performance Series Buckets along with the aggressive rack angles of the Cat Optimized Z-bar Loader will demonstrate fill factors greater than 100% ISO rated. Refer to the **Fill Factors** table for expected fill factor per material density and **Bucket Selection** table for bucket sizing.

910K — High Lift Fill Factors

Materials	Density	Fill %
Earth and rock	~ 1800 kg/m ³ ~ 3033 lb/yd ³	~ 115%
Sand & gravel	~ 1700 kg/m ³ ~ 2865 lb/yd ³	~ 115%
Aggregates	~ 1600 kg/m ³ ~ 2696 lb/yd ³	~ 105%
Bulk grains	~ 750 kg/m ³ ~ 1264 lb/yd ³	~ 100%
Woodchips	~ 500 kg/m ³ ~ 843 lb/yd ³	~ 100%

914K — Standard Lift

Bucket Fill Factor		kg/m ³	1450	1525	1600	1675	1750	1825	1900	1975	2050	2125	2200		
		lb/yd ³	2443	2570	2696	2822	2949	3075	3202	3328	3454	3581	3707		
		m ³											yd ³		
General Purpose	Pin On	1.3	1.7							113%	109%	105%	101%	98%	
		1.3	1.7							113%	109%	105%	101%	97%	
		1.5	2.0				115%	110%	105%	101%	97%				
	IT	1.2	1.6										111%	107%	104%
		1.3	1.7							111%	106%	102%	99%	96%	
		1.4	1.8				110%	106%	102%	98%	94%				
	ISO	1.5	2.0				112%	107%	102%	98%	94%				
		1.2	1.6										113%	109%	105%
		1.4	1.8				112%	108%	103%	99%	95%				

23

Material density and fill factor are key variables when choosing the appropriate size of the bucket. The long floor and open throat design of the Performance Series Buckets along with the aggressive rack angles of the Cat Optimized Z-bar Loader will demonstrate fill factors greater than 100% ISO rated. Refer to the **Fill Factors** table for expected fill factor per material density and **Bucket Selection** table for bucket sizing.

914K — Standard Lift Fill Factors

Materials	Density	Fill %
Earth and rock	~ 1800 kg/m ³ ~ 3033 lb/yd ³	~ 115%
Sand & gravel	~ 1700 kg/m ³ ~ 2865 lb/yd ³	~ 115%
Aggregates	~ 1600 kg/m ³ ~ 2696 lb/yd ³	~ 105%
Bulk grains	~ 750 kg/m ³ ~ 1264 lb/yd ³	~ 100%
Woodchips	~ 500 kg/m ³ ~ 843 lb/yd ³	~ 100%

914K — High Lift

Bucket Fill Factor		kg/m ³	1150	1225	1300	1375	1450	1525	1600	1675	1750	1825	1900	
		lb/yd ³	1938	2064	2191	2317	2443	2570	2696	2822	2949	3075	3202	
		m ³												
		yd ³												
General Purpose	Pin On	1.3	1.7					113%	107%	103%	98%	94%		
		1.3	1.7					113%	108%	103%	98%	94%		
		1.5	2.0	113%		107%	101%	96%						
	IT	1.2	1.6							114%	109%	105%	100%	96%
		1.3	1.7					111%	105%	101%	96%			
		1.4	1.8	113%		107%	101%	97%						
	ISO	1.5	2.0	110%		104%	99%	94%						
		1.2	1.6							112%	107%	102%	98%	94%
			1.4	1.8	110%		104%	99%	95%					

Material density and fill factor are key variables when choosing the appropriate size of the bucket. The long floor and open throat design of the Performance Series Buckets along with the aggressive rack angles of the Cat Optimized Z-bar Loader will demonstrate fill factors greater than 100% ISO rated. Refer to the **Fill Factors** table for expected fill factor per material density and **Bucket Selection** table for bucket sizing.

914K — High Lift Fill Factors

Materials	Density	Fill %
Earth and rock	~ 1800 kg/m ³ ~ 3033 lb/yd³	~ 115%
Sand & gravel	~ 1700 kg/m ³ ~ 2865 lb/yd³	~ 115%
Aggregates	~ 1600 kg/m ³ ~ 2696 lb/yd³	~ 105%
Bulk grains	~ 750 kg/m ³ ~ 1264 lb/yd³	~ 100%
Woodchips	~ 500 kg/m ³ ~ 843 lb/yd³	~ 100%

950M

Material Density		kg/m ³	700	800	900	1000	1100	1200	1300	1400	1500	1600	1700	1800	1900	2000	2100	2200	2300	2400	2500		
Standard Linkage	Pin On	General Purpose	2.70 m ³ (3.53 yd ³)												3.11 m ³ (4.07 yd ³)						2.70 m ³ (3.53 yd ³)		
			2.90 m ³ (3.79 yd ³)												3.34 m ³ (4.37 yd ³)						2.90 m ³ (3.79 yd ³)		
			3.10 m ³ (4.05 yd ³)												3.57 m ³ (4.67 yd ³)						3.10 m ³ (4.05 yd ³)		
			3.30 m ³ (4.32 yd ³)												3.80 m ³ (4.97 yd ³)						3.30 m ³ (4.32 yd ³)		
			3.40 m ³ (4.45 yd ³)												3.91 m ³ (5.11 yd ³)						3.40 m ³ (4.45 yd ³)		
			3.60 m ³ (4.71 yd ³)												4.14 m ³ (5.41 yd ³)						3.60 m ³ (4.71 yd ³)		
			3.80 m ³ (4.97 yd ³)												4.37 m ³ (5.72 yd ³)						3.80 m ³ (4.97 yd ³)		
			Material Handling	2.70 m ³ (3.53 yd ³)														3.11 m ³ (4.07 yd ³)					
	2.90 m ³ (3.79 yd ³)															3.34 m ³ (4.37 yd ³)						2.90 m ³ (3.79 yd ³)	
	3.10 m ³ (4.05 yd ³)															3.57 m ³ (4.67 yd ³)						3.10 m ³ (4.05 yd ³)	
	3.30 m ³ (4.32 yd ³)															3.80 m ³ (4.97 yd ³)						3.30 m ³ (4.32 yd ³)	
	3.40 m ³ (4.45 yd ³)															3.91 m ³ (5.11 yd ³)						3.40 m ³ (4.45 yd ³)	
	3.60 m ³ (4.71 yd ³)															4.14 m ³ (5.41 yd ³)						3.60 m ³ (4.71 yd ³)	
	3.80 m ³ (4.97 yd ³)															4.37 m ³ (5.72 yd ³)						3.80 m ³ (4.97 yd ³)	
	Hook On	General Purpose		2.70 m ³ (3.53 yd ³)													3.11 m ³ (4.07 yd ³)						2.70 m ³ (3.53 yd ³)
			2.90 m ³ (3.79 yd ³)														3.34 m ³ (4.37 yd ³)						2.90 m ³ (3.79 yd ³)
			3.10 m ³ (4.05 yd ³)														3.57 m ³ (4.67 yd ³)						3.10 m ³ (4.05 yd ³)
			3.30 m ³ (4.32 yd ³)														3.80 m ³ (4.97 yd ³)						3.30 m ³ (4.32 yd ³)
			3.40 m ³ (4.45 yd ³)														3.91 m ³ (5.11 yd ³)						3.40 m ³ (4.45 yd ³)
			3.60 m ³ (4.71 yd ³)														4.14 m ³ (5.41 yd ³)						3.60 m ³ (4.71 yd ³)
			3.80 m ³ (4.97 yd ³)														4.37 m ³ (5.72 yd ³)						3.80 m ³ (4.97 yd ³)
			Material Handling	2.70 m ³ (3.53 yd ³)														3.11 m ³ (4.07 yd ³)					
	2.90 m ³ (3.79 yd ³)															3.34 m ³ (4.37 yd ³)						2.90 m ³ (3.79 yd ³)	
	3.10 m ³ (4.05 yd ³)															3.57 m ³ (4.67 yd ³)						3.10 m ³ (4.05 yd ³)	
3.30 m ³ (4.32 yd ³)															3.80 m ³ (4.97 yd ³)						3.30 m ³ (4.32 yd ³)		
3.40 m ³ (4.45 yd ³)															3.91 m ³ (5.11 yd ³)						3.40 m ³ (4.45 yd ³)		
3.60 m ³ (4.71 yd ³)															4.14 m ³ (5.41 yd ³)						3.60 m ³ (4.71 yd ³)		
3.80 m ³ (4.97 yd ³)															4.37 m ³ (5.72 yd ³)						3.80 m ³ (4.97 yd ³)		
Material Density	lb/yd ³	1180		1348	1517	1685	1854	2022	2191	2359	2528	2696	2865	3033	3202	3370	3539	3707	3876	4044	4213		
Bucket Fill Factors		115% 110% 105% 100% 95%																					

NOTE: All buckets are showing Bolt-On Edges.
Machine and bucket availability varies by region. Contact your local Cat dealer for product availability.

962M

Material Density		kg/m ³	700	800	900	1000	1100	1200	1300	1400	1500	1600	1700	1800	1900	2000	2100	2200	2300	2400	2500	
Standard Linkage	Pin On	General Purpose	2.70 m ³ (3.53 yd ³)													3.11 m ³ (4.07 yd ³)					2.70 m ³ (3.53 yd ³)	
			2.90 m ³ (3.79 yd ³)													3.34 m ³ (4.37 yd ³)					2.90 m ³ (3.79 yd ³)	
			3.10 m ³ (4.05 yd ³)													3.57 m ³ (4.67 yd ³)					3.10 m ³ (4.05 yd ³)	
			3.30 m ³ (4.32 yd ³)													3.80 m ³ (4.97 yd ³)					3.30 m ³ (4.32 yd ³)	
			3.40 m ³ (4.45 yd ³)													3.91 m ³ (5.11 yd ³)					3.40 m ³ (4.45 yd ³)	
			3.60 m ³ (4.71 yd ³)													4.14 m ³ (5.41 yd ³)					3.60 m ³ (4.71 yd ³)	
			3.80 m ³ (4.97 yd ³)													4.37 m ³ (5.72 yd ³)					3.80 m ³ (4.97 yd ³)	
	Material Handling	2.70 m ³ (3.53 yd ³)															3.11 m ³ (4.07 yd ³)					2.70 m ³ (3.53 yd ³)
		2.90 m ³ (3.79 yd ³)															3.34 m ³ (4.37 yd ³)					2.90 m ³ (3.79 yd ³)
		3.10 m ³ (4.05 yd ³)															3.57 m ³ (4.67 yd ³)					3.10 m ³ (4.05 yd ³)
		3.30 m ³ (4.32 yd ³)															3.80 m ³ (4.97 yd ³)					3.30 m ³ (4.32 yd ³)
		3.40 m ³ (4.45 yd ³)															3.91 m ³ (5.11 yd ³)					3.40 m ³ (4.45 yd ³)
		3.60 m ³ (4.71 yd ³)															4.14 m ³ (5.41 yd ³)					3.60 m ³ (4.71 yd ³)
		3.80 m ³ (4.97 yd ³)															4.37 m ³ (5.72 yd ³)					3.80 m ³ (4.97 yd ³)
Hook On	General Purpose	2.70 m ³ (3.53 yd ³)														3.11 m ³ (4.07 yd ³)					2.70 m ³ (3.53 yd ³)	
		2.90 m ³ (3.79 yd ³)															3.34 m ³ (4.37 yd ³)					2.90 m ³ (3.79 yd ³)
		3.10 m ³ (4.05 yd ³)															3.57 m ³ (4.67 yd ³)					3.10 m ³ (4.05 yd ³)
		3.30 m ³ (4.32 yd ³)															3.80 m ³ (4.97 yd ³)					3.30 m ³ (4.32 yd ³)
		3.40 m ³ (4.45 yd ³)															3.91 m ³ (5.11 yd ³)					3.40 m ³ (4.45 yd ³)
		3.60 m ³ (4.71 yd ³)															4.14 m ³ (5.41 yd ³)					3.60 m ³ (4.71 yd ³)
		3.80 m ³ (4.97 yd ³)															4.37 m ³ (5.72 yd ³)					3.80 m ³ (4.97 yd ³)
Material Handling	2.70 m ³ (3.53 yd ³)															3.11 m ³ (4.07 yd ³)					2.70 m ³ (3.53 yd ³)	
	2.90 m ³ (3.79 yd ³)															3.34 m ³ (4.37 yd ³)					2.90 m ³ (3.79 yd ³)	
	3.10 m ³ (4.05 yd ³)															3.57 m ³ (4.67 yd ³)					3.10 m ³ (4.05 yd ³)	
	3.30 m ³ (4.32 yd ³)															3.80 m ³ (4.97 yd ³)					3.30 m ³ (4.32 yd ³)	
	3.40 m ³ (4.45 yd ³)															3.91 m ³ (5.11 yd ³)					3.40 m ³ (4.45 yd ³)	
	3.60 m ³ (4.71 yd ³)															4.14 m ³ (5.41 yd ³)					3.60 m ³ (4.71 yd ³)	
	3.80 m ³ (4.97 yd ³)															4.37 m ³ (5.72 yd ³)					3.80 m ³ (4.97 yd ³)	
Material Density	lb/yd ³	1180	1348	1517	1685	1854	2022	2191	2359	2528	2696	2865	3033	3202	3370	3539	3707	3876	4044	4213		
Bucket Fill Factors		115% 110% 105% 100% 95% 																				

NOTE: All buckets are showing Bolt-On Edges.

Machine and bucket availability varies by region. Contact your local Cat dealer for product availability.

962M

Material Density		kg/m ³	700	800	900	1000	1100	1200	1300	1400	1500	1600	1700	1800	1900	2000	2100	2200	2300	2400	2500		
Aggregate Package Linkage Pin On General Purpose	3.80 m ³ (4.97 yd ³)									4.37 m ³ (5.72 yd ³)													
	4.00 m ³ (5.23 yd ³)								4.60 m ³ (6.02 yd ³)														
	4.20 m ³ (5.49 yd ³)							4.83 m ³ (6.32 yd ³)				4.20 m ³ (5.49 yd ³)											
Material Density	lb/yd ³		1180	1348	1517	1685	1854	2022	2191	2359	2528	2696	2865	3033	3202	3370	3539	3707	3876	4044	4213		
Bucket Fill Factors 115% 110% 105% 100% 95%																							

NOTE: All buckets are showing Bolt-On Edges.
Machine and bucket availability varies by region. Contact your local Cat dealer for product availability.

966M

Material Density		kg/m ³	700	800	900	1000	1100	1200	1300	1400	1500	1600	1700	1800	1900	2000	2100	2200	2300	2400	2500		
Standard Linkage	Pin On	General Purpose	3.80 m ³ (5.00 yd ³)											4.37 m ³ (5.72 yd ³)							3.80 m ³ (5.00 yd ³)		
			4.00 m ³ (5.25 yd ³)											4.60 m ³ (6.02 yd ³)							4.00 m ³ (5.25 yd ³)		
			4.20 m ³ (5.50 yd ³)											4.83 m ³ (6.32 yd ³)							4.20 m ³ (5.50 yd ³)		
	Fusion QC	General Purpose	3.80 m ³ (5.00 yd ³)												4.37 m ³ (5.72 yd ³)							3.80 m ³ (5.00 yd ³)	
			4.00 m ³ (5.25 yd ³)												4.60 m ³ (6.02 yd ³)							4.00 m ³ (5.25 yd ³)	
			4.20 m ³ (5.50 yd ³)												4.83 m ³ (6.32 yd ³)							4.20 m ³ (5.50 yd ³)	
	Pin On	Material Handling	4.20 m ³ (5.50 yd ³)												4.83 m ³ (6.32 yd ³)							4.20 m ³ (5.50 yd ³)	
			3.80 m ³ (5.00 yd ³)													4.37 m ³ (5.72 yd ³)							3.80 m ³ (5.00 yd ³)
			4.00 m ³ (5.25 yd ³)													4.60 m ³ (6.02 yd ³)							4.00 m ³ (5.25 yd ³)
High Lift Linkage	Pin On	General Purpose	3.80 m ³ (5.00 yd ³)											4.37 m ³ (5.72 yd ³)							3.80 m ³ (5.00 yd ³)		
			4.00 m ³ (5.25 yd ³)												4.60 m ³ (6.02 yd ³)							4.00 m ³ (5.25 yd ³)	
			4.20 m ³ (5.50 yd ³)												4.83 m ³ (6.32 yd ³)							4.20 m ³ (5.50 yd ³)	
	Fusion QC	General Purpose	3.80 m ³ (5.00 yd ³)												4.37 m ³ (5.72 yd ³)							3.80 m ³ (5.00 yd ³)	
			4.00 m ³ (5.25 yd ³)												4.60 m ³ (6.02 yd ³)							4.00 m ³ (5.25 yd ³)	
			4.20 m ³ (5.50 yd ³)												4.83 m ³ (6.32 yd ³)							4.20 m ³ (5.50 yd ³)	
	Pin On	Material Handling	4.20 m ³ (5.50 yd ³)												4.83 m ³ (6.32 yd ³)							4.20 m ³ (5.50 yd ³)	
			3.80 m ³ (5.00 yd ³)													4.37 m ³ (5.72 yd ³)							3.80 m ³ (5.00 yd ³)
			4.00 m ³ (5.25 yd ³)													4.60 m ³ (6.02 yd ³)							4.00 m ³ (5.25 yd ³)
Aggregate Handler Package	Pin On	General Purpose	3.80 m ³ (5.00 yd ³)											4.37 m ³ (5.72 yd ³)							3.80 m ³ (5.00 yd ³)		
			4.00 m ³ (5.25 yd ³)												4.60 m ³ (6.02 yd ³)							4.00 m ³ (5.25 yd ³)	
			4.20 m ³ (5.50 yd ³)												4.83 m ³ (6.32 yd ³)							4.20 m ³ (5.50 yd ³)	
	Fusion QC	General Purpose	3.80 m ³ (5.00 yd ³)												4.37 m ³ (5.72 yd ³)							3.80 m ³ (5.00 yd ³)	
			4.00 m ³ (5.25 yd ³)												4.60 m ³ (6.02 yd ³)							4.00 m ³ (5.25 yd ³)	
			4.20 m ³ (5.50 yd ³)												4.83 m ³ (6.32 yd ³)							4.20 m ³ (5.50 yd ³)	
	Pin On	Material Handling	4.20 m ³ (5.50 yd ³)												4.83 m ³ (6.32 yd ³)							4.20 m ³ (5.50 yd ³)	
			3.80 m ³ (5.00 yd ³)													4.37 m ³ (5.72 yd ³)							3.80 m ³ (5.00 yd ³)
			4.00 m ³ (5.25 yd ³)													4.60 m ³ (6.02 yd ³)							4.00 m ³ (5.25 yd ³)
Material Density	lb/yd ³	1180	1348	1517	1685	1854	2022	2191	2359	2528	2696	2865	3033	3202	3370	3539	3707	3876	4044	4213			
Bucket Fill Factors																							
115% 110% 105% 100% 95%																							

NOTE: All buckets are showing Bolt-On Edges.
Machine and bucket availability varies by region. Contact your local Cat dealer for product availability.

972M

Material Density		kg/m ³	700	800	900	1000	1100	1200	1300	1400	1500	1600	1700	1800	1900	2000	2100	2200	2300	2400	2500			
Standard Linkage	Pin On	General Purpose	4.60 m ³ (6.00 yd ³)																					
			4.80 m ³ (6.25 yd ³)																					
			5.00 m ³ (6.50 yd ³)																					
Standard Linkage	Fusion OC	General Purpose	4.40 m ³ (5.75 yd ³)																					
			4.60 m ³ (6.00 yd ³)																					
			4.80 m ³ (6.25 yd ³)																					
High Lift Linkage	Pin On	General Purpose	4.60 m ³ (6.00 yd ³)																					
			4.80 m ³ (6.25 yd ³)																					
			5.00 m ³ (6.50 yd ³)																					
High Lift Linkage	Fusion OC	General Purpose	4.40 m ³ (5.75 yd ³)																					
			4.60 m ³ (6.00 yd ³)																					
			4.80 m ³ (6.25 yd ³)																					
Extended Linkage	Fusion OC	General Purpose	4.90 m ³ (6.41 yd ³)																					
			5.10 m ³ (6.67 yd ³)																					
			5.30 m ³ (6.93 yd ³)																					
Aggregate Handler Package	Pin On	General Purpose	5.10 m ³ (6.67 yd ³)																					
			5.30 m ³ (6.93 yd ³)																					
			5.50 m ³ (7.19 yd ³)																					
Material Density		lb/yd ³	1180	1348	1517	1685	1854	2022	2191	2359	2528	2696	2865	3033	3202	3370	3539	3707	3876	4044	4213			
Bucket Fill Factors		115% 110% 105% 100% 95%																						

NOTE: All buckets are showing Bolt-On Edges.
Machine and bucket availability varies by region. Contact your local Cat dealer for product availability.

980M

Material Density		kg/m ³	700	800	900	1000	1100	1200	1300	1400	1500	1600	1700	1800	1900	2000	2100	2200	2300	2400	2500	
Standard Linkage	Pin On	General Purpose	5.40 m ³ (7.06 yd ³)										6.21 m ³ (8.12 yd ³)		5.40 m ³ (7.06 yd ³)							
		Rock	4.40 m ³ (5.75 yd ³)											5.06 m ³ (6.62 yd ³)		4.40 m ³ (5.75 yd ³)						
		Coal	8.20 m ³ (10.73 yd ³)			9.43 m ³ (12.33 yd ³)				8.20 m ³ (10.73 yd ³)												
Aggregate Handler	Pin On	General Purpose	5.70 m ³ (7.46 yd ³)											6.56 m ³ (8.58 yd ³)		5.70 m ³ (7.46 yd ³)						
			6.00 m ³ (7.85 yd ³)											6.90 m ³ (9.025 yd ³)		6.00 m ³ (7.85 yd ³)						
	Material Handling	5.70 m ³ (7.46 yd ³)												6.56 m ³ (8.58 yd ³)		5.70 m ³ (7.46 yd ³)						
	Coal	8.20 m ³ (10.73 yd ³)			9.43 m ³ (12.33 yd ³)				8.20 m ³ (10.73 yd ³)													
Material Density		lb/yd ³	1180	1348	1517	1685	1854	2022	2191	2359	2528	2696	2865	3033	3202	3370	3539	3707	3876	4044	4213	
Bucket Fill Factors																						

NOTE: All buckets are showing Bolt-On Edges.
Machine and bucket availability varies by region. Contact your local Cat dealer for product availability.

950K

Material Density		kg/m ³	700	800	900	1000	1100	1200	1300	1400	1500	1600	1700	1800	1900	2000	2100	2200	2300	2400	2500	
Standard Linkage	Pin On	General Purpose	2.70 m ³ (3.53 yd ³)												3.11 m ³ (4.07 yd ³)						2.70 m ³ (3.53 yd ³)	
			2.90 m ³ (3.79 yd ³)												3.34 m ³ (4.37 yd ³)						2.90 m ³ (3.79 yd ³)	
			3.10 m ³ (4.05 yd ³)												3.57 m ³ (4.67 yd ³)						3.10 m ³ (4.05 yd ³)	
			3.30 m ³ (4.32 yd ³)												3.80 m ³ (4.97 yd ³)						3.30 m ³ (4.32 yd ³)	
			3.40 m ³ (4.45 yd ³)												3.91 m ³ (5.11 yd ³)						3.40 m ³ (4.45 yd ³)	
			3.60 m ³ (4.71 yd ³)												4.14 m ³ (5.41 yd ³)						3.60 m ³ (4.71 yd ³)	
			3.80 m ³ (4.97 yd ³)												4.37 m ³ (5.72 yd ³)						3.80 m ³ (4.97 yd ³)	
	Material Handling	2.70 m ³ (3.53 yd ³)														3.11 m ³ (4.07 yd ³)						2.70 m ³ (3.53 yd ³)
		2.90 m ³ (3.79 yd ³)														3.34 m ³ (4.37 yd ³)						2.90 m ³ (3.79 yd ³)
		3.10 m ³ (4.05 yd ³)														3.57 m ³ (4.67 yd ³)						3.10 m ³ (4.05 yd ³)
		3.30 m ³ (4.32 yd ³)														3.80 m ³ (4.97 yd ³)						3.30 m ³ (4.32 yd ³)
		3.40 m ³ (4.45 yd ³)														3.91 m ³ (5.11 yd ³)						3.40 m ³ (4.45 yd ³)
		3.60 m ³ (4.71 yd ³)														4.14 m ³ (5.41 yd ³)						3.60 m ³ (4.71 yd ³)
		3.80 m ³ (4.97 yd ³)														4.37 m ³ (5.72 yd ³)						3.80 m ³ (4.97 yd ³)
Fusion QC	General Purpose	2.70 m ³ (3.53 yd ³)													3.11 m ³ (4.07 yd ³)						2.70 m ³ (3.53 yd ³)	
		2.90 m ³ (3.79 yd ³)														3.34 m ³ (4.37 yd ³)						2.90 m ³ (3.79 yd ³)
		3.10 m ³ (4.05 yd ³)														3.57 m ³ (4.67 yd ³)						3.10 m ³ (4.05 yd ³)
		3.30 m ³ (4.32 yd ³)														3.80 m ³ (4.97 yd ³)						3.30 m ³ (4.32 yd ³)
		3.40 m ³ (4.45 yd ³)														3.91 m ³ (5.11 yd ³)						3.40 m ³ (4.45 yd ³)
		3.60 m ³ (4.71 yd ³)														4.14 m ³ (5.41 yd ³)						3.60 m ³ (4.71 yd ³)
		3.80 m ³ (4.97 yd ³)														4.37 m ³ (5.72 yd ³)						3.80 m ³ (4.97 yd ³)
Material Handling	2.70 m ³ (3.53 yd ³)														3.11 m ³ (4.07 yd ³)						2.70 m ³ (3.53 yd ³)	
	2.90 m ³ (3.79 yd ³)														3.34 m ³ (4.37 yd ³)						2.90 m ³ (3.79 yd ³)	
	3.10 m ³ (4.05 yd ³)														3.57 m ³ (4.67 yd ³)						3.10 m ³ (4.05 yd ³)	
	3.30 m ³ (4.32 yd ³)														3.80 m ³ (4.97 yd ³)						3.30 m ³ (4.32 yd ³)	
	3.40 m ³ (4.45 yd ³)														3.91 m ³ (5.11 yd ³)						3.40 m ³ (4.45 yd ³)	
	3.60 m ³ (4.71 yd ³)														4.14 m ³ (5.41 yd ³)						3.60 m ³ (4.71 yd ³)	
	3.80 m ³ (4.97 yd ³)														4.37 m ³ (5.72 yd ³)						3.80 m ³ (4.97 yd ³)	
Material Density	lb/yd ³	1180	1348	1517	1685	1854	2022	2191	2359	2528	2696	2865	3033	3202	3370	3539	3707	3876	4044	4213		
Bucket Fill Factors 115% 110% 105% 100% 95%																						

NOTE: All buckets are showing Bolt-On Edges. Material Handling buckets are flat floor buckets.
Contact your local Cat dealer for product availability.

950K

Material Density		kg/m ³	700	800	900	1000	1100	1200	1300	1400	1500	1600	1700	1800	1900	2000	2100	2200	2300	2400	2500			
High Lift Linkage	Pin On	General Purpose	2.70 m ³ (3.53 yd ³)																					
			2.90 m ³ (3.79 yd ³)																					
			3.10 m ³ (4.05 yd ³)																					
			3.30 m ³ (4.32 yd ³)																					
			3.40 m ³ (4.45 yd ³)																					
			3.60 m ³ (4.71 yd ³)																					
			3.80 m ³ (4.97 yd ³)																					
	Material Handling	2.70 m ³ (3.53 yd ³)																						
		2.90 m ³ (3.79 yd ³)																						
		3.10 m ³ (4.05 yd ³)																						
		3.30 m ³ (4.32 yd ³)																						
		3.40 m ³ (4.45 yd ³)																						
		3.60 m ³ (4.71 yd ³)																						
		3.80 m ³ (4.97 yd ³)																						
Fusion QC	General Purpose	2.70 m ³ (3.53 yd ³)																						
		2.90 m ³ (3.79 yd ³)																						
		3.10 m ³ (4.05 yd ³)																						
		3.30 m ³ (4.32 yd ³)																						
		3.40 m ³ (4.45 yd ³)																						
		3.60 m ³ (4.71 yd ³)																						
		3.80 m ³ (4.97 yd ³)																						
Material Handling	2.70 m ³ (3.53 yd ³)																							
	2.90 m ³ (3.79 yd ³)																							
	3.10 m ³ (4.05 yd ³)																							
	3.30 m ³ (4.32 yd ³)																							
	3.40 m ³ (4.45 yd ³)																							
	3.60 m ³ (4.71 yd ³)																							
	3.80 m ³ (4.97 yd ³)																							
Material Density	lb/yd ³	1180	1348	1517	1685	1854	2022	2191	2359	2528	2696	2865	3033	3202	3370	3539	3707	3876	4044	4213				
Bucket Fill Factors		115% 110% 105% 100% 95% 																						

NOTE: All buckets are showing Bolt-On Edges. Material Handling buckets are flat floor buckets. Contact your local Cat dealer for product availability.

950K

Material Density		kg/m ³	700	800	900	1000	1100	1200	1300	1400	1500	1600	1700	1800	1900	2000	2100	2200	2300	2400	2500	
Power Package	Pin On	General Purpose	2.70 m ³ (3.53 yd ³)													3.11 m ³ (4.07 yd ³)					2.70 m ³ (3.53 yd ³)	
			2.90 m ³ (3.79 yd ³)												3.34 m ³ (4.37 yd ³)					2.90 m ³ (3.79 yd ³)		
			3.10 m ³ (4.05 yd ³)												3.57 m ³ (4.67 yd ³)					3.10 m ³ (4.05 yd ³)		
			3.30 m ³ (4.32 yd ³)												3.80 m ³ (4.97 yd ³)					3.30 m ³ (4.32 yd ³)		
			3.40 m ³ (4.45 yd ³)												3.91 m ³ (5.11 yd ³)					3.40 m ³ (4.45 yd ³)		
			3.60 m ³ (4.71 yd ³)												4.14 m ³ (5.41 yd ³)					3.60 m ³ (4.71 yd ³)		
			3.80 m ³ (4.97 yd ³)												4.37 m ³ (5.72 yd ³)					3.80 m ³ (4.97 yd ³)		
	Material Handling	2.70 m ³ (3.53 yd ³)															3.11 m ³ (4.07 yd ³)					2.70 m ³ (3.53 yd ³)
		2.90 m ³ (3.79 yd ³)															3.34 m ³ (4.37 yd ³)					2.90 m ³ (3.79 yd ³)
		3.10 m ³ (4.05 yd ³)															3.57 m ³ (4.67 yd ³)					3.10 m ³ (4.05 yd ³)
		3.30 m ³ (4.32 yd ³)															3.80 m ³ (4.97 yd ³)					3.30 m ³ (4.32 yd ³)
		3.40 m ³ (4.45 yd ³)															3.91 m ³ (5.11 yd ³)					3.40 m ³ (4.45 yd ³)
		3.60 m ³ (4.71 yd ³)															4.14 m ³ (5.41 yd ³)					3.60 m ³ (4.71 yd ³)
		3.80 m ³ (4.97 yd ³)															4.37 m ³ (5.72 yd ³)					3.80 m ³ (4.97 yd ³)
Fusion QC	General Purpose	2.70 m ³ (3.53 yd ³)														3.11 m ³ (4.07 yd ³)					2.70 m ³ (3.53 yd ³)	
		2.90 m ³ (3.79 yd ³)															3.34 m ³ (4.37 yd ³)					2.90 m ³ (3.79 yd ³)
		3.10 m ³ (4.05 yd ³)															3.57 m ³ (4.67 yd ³)					3.10 m ³ (4.05 yd ³)
		3.30 m ³ (4.32 yd ³)															3.80 m ³ (4.97 yd ³)					3.30 m ³ (4.32 yd ³)
		3.40 m ³ (4.45 yd ³)															3.91 m ³ (5.11 yd ³)					3.40 m ³ (4.45 yd ³)
		3.60 m ³ (4.71 yd ³)															4.14 m ³ (5.41 yd ³)					3.60 m ³ (4.71 yd ³)
		3.80 m ³ (4.97 yd ³)															4.37 m ³ (5.72 yd ³)					3.80 m ³ (4.97 yd ³)
Material Handling	2.70 m ³ (3.53 yd ³)															3.11 m ³ (4.07 yd ³)					2.70 m ³ (3.53 yd ³)	
	2.90 m ³ (3.79 yd ³)															3.34 m ³ (4.37 yd ³)					2.90 m ³ (3.79 yd ³)	
	3.10 m ³ (4.05 yd ³)															3.57 m ³ (4.67 yd ³)					3.10 m ³ (4.05 yd ³)	
	3.30 m ³ (4.32 yd ³)															3.80 m ³ (4.97 yd ³)					3.30 m ³ (4.32 yd ³)	
	3.40 m ³ (4.45 yd ³)															3.91 m ³ (5.11 yd ³)					3.40 m ³ (4.45 yd ³)	
	3.60 m ³ (4.71 yd ³)															4.14 m ³ (5.41 yd ³)					3.60 m ³ (4.71 yd ³)	
	3.80 m ³ (4.97 yd ³)															4.37 m ³ (5.72 yd ³)					3.80 m ³ (4.97 yd ³)	
Material Density	lb/yd ³	1180	1348	1517	1685	1854	2022	2191	2359	2528	2696	2865	3033	3202	3370	3539	3707	3876	4044	4213		
Bucket Fill Factors		115% 110% 105% 100% 95% 																				

NOTE: All buckets are showing Bolt-On Edges. Material Handling buckets are flat floor buckets.
Contact your local Cat dealer for product availability.

962K

Material Density		kg/m ³	700	800	900	1000	1100	1200	1300	1400	1500	1600	1700	1800	1900	2000	2100	2200	2300	2400	2500	
Standard Linkage	Pin On	General Purpose	2.70 m ³ (3.53 yd ³)													3.11 m ³ (4.07 yd ³)					2.70 m ³ (3.53 yd ³)	
			2.90 m ³ (3.79 yd ³)													3.34 m ³ (4.37 yd ³)					2.90 m ³ (3.79 yd ³)	
			3.10 m ³ (4.05 yd ³)													3.57 m ³ (4.67 yd ³)					3.10 m ³ (4.05 yd ³)	
			3.30 m ³ (4.32 yd ³)													3.80 m ³ (4.97 yd ³)					3.30 m ³ (4.32 yd ³)	
			3.40 m ³ (4.45 yd ³)													3.91 m ³ (5.11 yd ³)					3.40 m ³ (4.45 yd ³)	
			3.60 m ³ (4.71 yd ³)													4.14 m ³ (5.41 yd ³)					3.60 m ³ (4.71 yd ³)	
			3.80 m ³ (4.97 yd ³)													4.37 m ³ (5.72 yd ³)					3.80 m ³ (4.97 yd ³)	
	Material Handling	2.70 m ³ (3.53 yd ³)															3.11 m ³ (4.07 yd ³)					2.70 m ³ (3.53 yd ³)
		2.90 m ³ (3.79 yd ³)															3.34 m ³ (4.37 yd ³)					2.90 m ³ (3.79 yd ³)
		3.10 m ³ (4.05 yd ³)															3.57 m ³ (4.67 yd ³)					3.10 m ³ (4.05 yd ³)
		3.30 m ³ (4.32 yd ³)															3.80 m ³ (4.97 yd ³)					3.30 m ³ (4.32 yd ³)
		3.40 m ³ (4.45 yd ³)															3.91 m ³ (5.11 yd ³)					3.40 m ³ (4.45 yd ³)
		3.60 m ³ (4.71 yd ³)															4.14 m ³ (5.41 yd ³)					3.60 m ³ (4.71 yd ³)
		3.80 m ³ (4.97 yd ³)															4.37 m ³ (5.72 yd ³)					3.80 m ³ (4.97 yd ³)
Fusion QC	General Purpose	2.70 m ³ (3.53 yd ³)														3.11 m ³ (4.07 yd ³)					2.70 m ³ (3.53 yd ³)	
		2.90 m ³ (3.79 yd ³)															3.34 m ³ (4.37 yd ³)					2.90 m ³ (3.79 yd ³)
		3.10 m ³ (4.05 yd ³)															3.57 m ³ (4.67 yd ³)					3.10 m ³ (4.05 yd ³)
		3.30 m ³ (4.32 yd ³)															3.80 m ³ (4.97 yd ³)					3.30 m ³ (4.32 yd ³)
		3.40 m ³ (4.45 yd ³)															3.91 m ³ (5.11 yd ³)					3.40 m ³ (4.45 yd ³)
		3.60 m ³ (4.71 yd ³)															4.14 m ³ (5.41 yd ³)					3.60 m ³ (4.71 yd ³)
		3.80 m ³ (4.97 yd ³)															4.37 m ³ (5.72 yd ³)					3.80 m ³ (4.97 yd ³)
Material Handling	2.70 m ³ (3.53 yd ³)															3.11 m ³ (4.07 yd ³)					2.70 m ³ (3.53 yd ³)	
	2.90 m ³ (3.79 yd ³)															3.34 m ³ (4.37 yd ³)					2.90 m ³ (3.79 yd ³)	
	3.10 m ³ (4.05 yd ³)															3.57 m ³ (4.67 yd ³)					3.10 m ³ (4.05 yd ³)	
	3.30 m ³ (4.32 yd ³)															3.80 m ³ (4.97 yd ³)					3.30 m ³ (4.32 yd ³)	
	3.40 m ³ (4.45 yd ³)															3.91 m ³ (5.11 yd ³)					3.40 m ³ (4.45 yd ³)	
	3.60 m ³ (4.71 yd ³)															4.14 m ³ (5.41 yd ³)					3.60 m ³ (4.71 yd ³)	
	3.80 m ³ (4.97 yd ³)															4.37 m ³ (5.72 yd ³)					3.80 m ³ (4.97 yd ³)	
Material Density	lb/yd ³	1180	1348	1517	1685	1854	2022	2191	2359	2528	2696	2865	3033	3202	3370	3539	3707	3876	4044	4213		
Bucket Fill Factors		115% 110% 105% 100% 95%																				

NOTE: All buckets are showing Bolt-On Edges. Material Handling buckets are flat floor buckets. Contact your local Cat dealer for product availability.

962K

Material Density		kg/m ³	700	800	900	1000	1100	1200	1300	1400	1500	1600	1700	1800	1900	2000	2100	2200	2300	2400	2500	
High Lift Linkage	Pin On	General Purpose	2.70 m ³ (3.53 yd ³)												3.11 m ³ (4.07 yd ³)						2.70 m ³ (3.53 yd ³)	
			2.90 m ³ (3.79 yd ³)												3.34 m ³ (4.37 yd ³)						2.90 m ³ (3.79 yd ³)	
			3.10 m ³ (4.05 yd ³)													3.57 m ³ (4.67 yd ³)						3.10 m ³ (4.05 yd ³)
			3.30 m ³ (4.32 yd ³)													3.80 m ³ (4.97 yd ³)						3.30 m ³ (4.32 yd ³)
			3.40 m ³ (4.45 yd ³)													3.91 m ³ (5.11 yd ³)						3.40 m ³ (4.45 yd ³)
			3.60 m ³ (4.71 yd ³)													4.14 m ³ (5.41 yd ³)						3.60 m ³ (4.71 yd ³)
			3.80 m ³ (4.97 yd ³)													4.37 m ³ (5.72 yd ³)						3.80 m ³ (4.97 yd ³)
	Material Handling	2.70 m ³ (3.53 yd ³)														3.11 m ³ (4.07 yd ³)						2.70 m ³ (3.53 yd ³)
		2.90 m ³ (3.79 yd ³)														3.34 m ³ (4.37 yd ³)						2.90 m ³ (3.79 yd ³)
		3.10 m ³ (4.05 yd ³)														3.57 m ³ (4.67 yd ³)						3.10 m ³ (4.05 yd ³)
		3.30 m ³ (4.32 yd ³)														3.80 m ³ (4.97 yd ³)						3.30 m ³ (4.32 yd ³)
		3.40 m ³ (4.45 yd ³)														3.91 m ³ (5.11 yd ³)						3.40 m ³ (4.45 yd ³)
		3.60 m ³ (4.71 yd ³)														4.14 m ³ (5.41 yd ³)						3.60 m ³ (4.71 yd ³)
		3.80 m ³ (4.97 yd ³)														4.37 m ³ (5.72 yd ³)						3.80 m ³ (4.97 yd ³)
Fusion QC	General Purpose	2.70 m ³ (3.53 yd ³)													3.11 m ³ (4.07 yd ³)						2.70 m ³ (3.53 yd ³)	
		2.90 m ³ (3.79 yd ³)														3.34 m ³ (4.37 yd ³)						2.90 m ³ (3.79 yd ³)
		3.10 m ³ (4.05 yd ³)														3.57 m ³ (4.67 yd ³)						3.10 m ³ (4.05 yd ³)
		3.30 m ³ (4.32 yd ³)														3.80 m ³ (4.97 yd ³)						3.30 m ³ (4.32 yd ³)
		3.40 m ³ (4.45 yd ³)														3.91 m ³ (5.11 yd ³)						3.40 m ³ (4.45 yd ³)
		3.60 m ³ (4.71 yd ³)														4.14 m ³ (5.41 yd ³)						3.60 m ³ (4.71 yd ³)
		3.80 m ³ (4.97 yd ³)														4.37 m ³ (5.72 yd ³)						3.80 m ³ (4.97 yd ³)
Material Handling	2.70 m ³ (3.53 yd ³)														3.11 m ³ (4.07 yd ³)						2.70 m ³ (3.53 yd ³)	
	2.90 m ³ (3.79 yd ³)														3.34 m ³ (4.37 yd ³)						2.90 m ³ (3.79 yd ³)	
	3.10 m ³ (4.05 yd ³)														3.57 m ³ (4.67 yd ³)						3.10 m ³ (4.05 yd ³)	
	3.30 m ³ (4.32 yd ³)														3.80 m ³ (4.97 yd ³)						3.30 m ³ (4.32 yd ³)	
	3.40 m ³ (4.45 yd ³)														3.91 m ³ (5.11 yd ³)						3.40 m ³ (4.45 yd ³)	
	3.60 m ³ (4.71 yd ³)														4.14 m ³ (5.41 yd ³)						3.60 m ³ (4.71 yd ³)	
	3.80 m ³ (4.97 yd ³)														4.37 m ³ (5.72 yd ³)						3.80 m ³ (4.97 yd ³)	
Material Density	lb/yd ³	1180	1348	1517	1685	1854	2022	2191	2359	2528	2696	2865	3033	3202	3370	3539	3707	3876	4044	4213		
Bucket Fill Factors		115% 110% 105% 100% 95% 																				

NOTE: All buckets are showing Bolt-On Edges. Material Handling buckets are flat floor buckets.
Contact your local Cat dealer for product availability.

966K

Material Density		kg/m ³	700	800	900	1000	1100	1200	1300	1400	1500	1600	1700	1800	1900	2000	2100	2200	2300	2400	2500			
Standard Linkage	Pin On	General Purpose	3.80 m ³ (4.97 yd ³)											4.37 m ³ (5.72 yd ³)							3.80 m ³ (4.97 yd ³)			
			4.00 m ³ (5.23 yd ³)												4.60 m ³ (6.02 yd ³)							4.00 m ³ (5.23 yd ³)		
			4.20 m ³ (5.49 yd ³)												4.83 m ³ (6.32 yd ³)								4.20 m ³ (5.49 yd ³)	
			4.60 m ³ (6.02 yd ³)											5.29 m ³ (6.92 yd ³)									4.60 m ³ (6.02 yd ³)	
	Fusion OC	General Purpose	3.80 m ³ (4.97 yd ³)												4.37 m ³ (5.72 yd ³)							3.80 m ³ (4.97 yd ³)		
			4.20 m ³ (5.49 yd ³)												4.83 m ³ (6.32 yd ³)							4.20 m ³ (5.49 yd ³)		
			4.60 m ³ (6.02 yd ³)											5.29 m ³ (6.92 yd ³)								4.60 m ³ (6.02 yd ³)		
			7.10 m ³ (9.29 yd ³)	8.17 m ³ (10.69 yd ³)						7.10 m ³ (9.29 yd ³)														
	Pin On	Material Handling	4.20 m ³ (5.49 yd ³)												4.83 m ³ (6.32 yd ³)							4.20 m ³ (5.49 yd ³)		
			3.40 m ³ (4.45 yd ³)												3.91 m ³ (5.11 yd ³)							3.40 m ³ (4.45 yd ³)		
			7.10 m ³ (9.29 yd ³)	8.17 m ³ (10.69 yd ³)						7.10 m ³ (9.29 yd ³)														
			Fusion OC	General Purpose	3.80 m ³ (4.97 yd ³)												4.37 m ³ (5.72 yd ³)							3.80 m ³ (4.97 yd ³)
4.20 m ³ (5.49 yd ³)														4.83 m ³ (6.32 yd ³)							4.20 m ³ (5.49 yd ³)			
4.60 m ³ (6.02 yd ³)													5.29 m ³ (6.92 yd ³)								4.60 m ³ (6.02 yd ³)			
7.10 m ³ (9.29 yd ³)	8.17 m ³ (10.69 yd ³)								7.10 m ³ (9.29 yd ³)															
High Lift Linkage	Pin On	General Purpose	3.80 m ³ (4.97 yd ³)											4.37 m ³ (5.72 yd ³)							3.80 m ³ (4.97 yd ³)			
			4.00 m ³ (5.23 yd ³)												4.60 m ³ (6.02 yd ³)							4.00 m ³ (5.23 yd ³)		
			4.20 m ³ (5.49 yd ³)												4.83 m ³ (6.32 yd ³)								4.20 m ³ (5.49 yd ³)	
			4.60 m ³ (6.02 yd ³)											5.29 m ³ (6.92 yd ³)									4.60 m ³ (6.02 yd ³)	
Fusion OC	Material Handling	4.20 m ³ (5.49 yd ³)												4.83 m ³ (6.32 yd ³)							4.20 m ³ (5.49 yd ³)			
		3.40 m ³ (4.45 yd ³)												3.91 m ³ (5.11 yd ³)							3.40 m ³ (4.45 yd ³)			
		7.10 m ³ (9.29 yd ³)	8.17 m ³ (10.69 yd ³)						7.10 m ³ (9.29 yd ³)															
		Pin On	General Purpose	3.80 m ³ (4.97 yd ³)												4.37 m ³ (5.72 yd ³)							3.80 m ³ (4.97 yd ³)	
4.20 m ³ (5.49 yd ³)														4.83 m ³ (6.32 yd ³)							4.20 m ³ (5.49 yd ³)			
4.60 m ³ (6.02 yd ³)													5.29 m ³ (6.92 yd ³)								4.60 m ³ (6.02 yd ³)			
7.10 m ³ (9.29 yd ³)	8.17 m ³ (10.69 yd ³)								7.10 m ³ (9.29 yd ³)															
Material Density		lb/yd ³	1180	1348	1517	1685	1854	2022	2191	2359	2528	2696	2865	3033	3202	3370	3539	3707	3876	4044	4213			
Bucket Fill Factors		115% 110% 105% 100% 95%																						

NOTE: All buckets are showing Bolt-On Edges. Material Handling buckets are flat floor buckets. Contact your local Cat dealer for product availability.

972K

Material Density		kg/m ³	700	800	900	1000	1100	1200	1300	1400	1500	1600	1700	1800	1900	2000	2100	2200	2300	2400	2500				
Standard Linkage	Pin On	General Purpose	4.20 m ³ (5.49 yd ³)											4.83 m ³ (6.32 yd ³)								4.20 m ³ (5.49 yd ³)			
			4.40 m ³ (5.75 yd ³)												5.06 m ³ (6.62 yd ³)								4.40 m ³ (5.75 yd ³)		
			4.60 m ³ (6.02 yd ³)												5.29 m ³ (6.92 yd ³)								4.60 m ³ (6.02 yd ³)		
			4.80 m ³ (6.28 yd ³)												5.52 m ³ (7.22 yd ³)								4.80 m ³ (6.28 yd ³)		
			5.00 m ³ (6.54 yd ³)												5.75 m ³ (7.52 yd ³)								5.00 m ³ (6.54 yd ³)		
	Fusion OC	Material Handling	4.60 m ³ (6.02 yd ³)												5.29 m ³ (6.92 yd ³)								4.60 m ³ (6.02 yd ³)		
			Rock	3.60 m ³ (4.71 yd ³)												4.14 m ³ (5.42 yd ³)								3.42 m ³ (4.47 yd ³)	
				4.00 m ³ (5.23 yd ³)												4.60 m ³ (6.02 yd ³)								3.80 m ³ (4.97 yd ³)	
			Coal	7.10 m ³ (9.29 yd ³)				8.17 m ³ (10.69 yd ³)																	7.10 m ³ (9.29 yd ³)
				General Purpose	4.20 m ³ (5.49 yd ³)													4.83 m ³ (6.32 yd ³)							4.20 m ³ (5.49 yd ³)
4.40 m ³ (5.75 yd ³)															5.06 m ³ (6.62 yd ³)							4.40 m ³ (5.75 yd ³)			
Fusion OC	Material Handling	4.60 m ³ (6.02 yd ³)													5.29 m ³ (6.92 yd ³)							4.60 m ³ (6.02 yd ³)			
		Rock	4.80 m ³ (6.28 yd ³)												5.52 m ³ (7.22 yd ³)								4.80 m ³ (6.28 yd ³)		
			5.00 m ³ (6.54 yd ³)												5.75 m ³ (7.52 yd ³)								5.00 m ³ (6.54 yd ³)		
		Coal	3.60 m ³ (4.71 yd ³)													4.14 m ³ (5.42 yd ³)								3.42 m ³ (4.47 yd ³)	
			7.10 m ³ (9.29 yd ³)				8.17 m ³ (10.69 yd ³)																		7.10 m ³ (9.29 yd ³)
Material Density		lb/yd ³	1180	1348	1517	1685	1854	2022	2191	2359	2528	2696	2865	3033	3202	3370	3539	3707	3876	4044	4213				
Bucket Fill Factors																									
115% 110% 105% 100% 95%																									

NOTE: All buckets are showing Bolt-On Edges. Material Handling buckets are flat floor buckets. Contact your local Cat dealer for product availability.

972K

Material Density		kg/m ³	700	800	900	1000	1100	1200	1300	1400	1500	1600	1700	1800	1900	2000	2100	2200	2300	2400	2500		
High Lift Linkage	Pin On	General Purpose	4.20 m ³ (5.49 yd ³)											4.83 m ³ (6.32 yd ³)								4.20 m ³ (5.49 yd ³)	
			4.40 m ³ (5.75 yd ³)												5.06 m ³ (6.62 yd ³)								4.40 m ³ (5.75 yd ³)
			4.60 m ³ (6.02 yd ³)												5.29 m ³ (6.92 yd ³)								4.60 m ³ (6.02 yd ³)
			4.80 m ³ (6.28 yd ³)												5.52 m ³ (7.22 yd ³)								4.80 m ³ (6.28 yd ³)
			5.00 m ³ (6.54 yd ³)												5.75 m ³ (7.52 yd ³)								5.00 m ³ (6.54 yd ³)
	Material Handling	4.60 m ³ (6.02 yd ³)												5.29 m ³ (6.92 yd ³)								4.60 m ³ (6.02 yd ³)	
		Rock	3.60 m ³ (4.71 yd ³)												4.14 m ³ (5.42 yd ³)								3.42 m ³ (4.47 yd ³)
			4.00 m ³ (5.23 yd ³)												4.60 m ³ (6.02 yd ³)								3.80 m ³ (4.97 yd ³)
	Coal	7.10 m ³ (9.29 yd ³)																					
		8.17 m ³ (10.69 yd ³)																					
	Fusion OC	General Purpose	4.20 m ³ (5.49 yd ³)												4.83 m ³ (6.32 yd ³)								4.20 m ³ (5.49 yd ³)
4.40 m ³ (5.75 yd ³)															5.06 m ³ (6.62 yd ³)							4.40 m ³ (5.75 yd ³)	
4.60 m ³ (6.02 yd ³)															5.29 m ³ (6.92 yd ³)							4.60 m ³ (6.02 yd ³)	
4.80 m ³ (6.28 yd ³)															5.52 m ³ (7.22 yd ³)							4.80 m ³ (6.28 yd ³)	
5.00 m ³ (6.54 yd ³)															5.75 m ³ (7.52 yd ³)							5.00 m ³ (6.54 yd ³)	
Rock		3.60 m ³ (4.71 yd ³)													4.14 m ³ (5.42 yd ³)								3.42 m ³ (4.47 yd ³)
	4.00 m ³ (5.23 yd ³)													4.60 m ³ (6.02 yd ³)								3.80 m ³ (4.97 yd ³)	
Coal	7.10 m ³ (9.29 yd ³)																						
Material Density		lb/yd ³	1180	1348	1517	1685	1854	2022	2191	2359	2528	2696	2865	3033	3202	3370	3539	3707	3876	4044	4213		
Bucket Fill Factors																							

Material Density		kg/m ³	700	800	900	1000	1100	1200	1300	1400	1500	1600	1700	1800	1900	2000	2100	2200	2300	2400	2500		
Extended Capacity Linkage	Pin On	General Purpose	4.60 m ³ (6.02 yd ³)																				
			4.90 m ³ (6.41 yd ³)																				
	Fusion OC	General Purpose	4.60 m ³ (6.02 yd ³)																				
			4.90 m ³ (6.41 yd ³)																				
Material Density		lb/yd ³	1180	1348	1517	1685	1854	2022	2191	2359	2528	2696	2865	3033	3202	3370	3539	3707	3876	4044	4213		
Bucket Fill Factors																							

NOTE: All buckets are showing Bolt-On Edges. Material Handling buckets are flat floor buckets. Contact your local Cat dealer for product availability.

980K

Material Density		kg/m ³	700	800	900	1000	1100	1200	1300	1400	1500	1600	1700	1800	1900	2000	2100	2200	2300	2400	2500		
Standard Linkage	Pin On	General Purpose	5.40 m ³ (7.06 yd ³)									6.21 m ³ (8.12 yd ³)			5.40 m ³ (7.06 yd ³)								
		Rock	4.40 m ³ (5.75 yd ³)										5.06 m ³ (6.62 yd ³)				4.40 m ³ (5.75 yd ³)						
		Coal	8.20 m ³ (10.73 yd ³)			9.43 m ³ (12.33 yd ³)			8.20 m ³ (10.73 yd ³)														
Material Density		lb/yd ³	1180	1348	1517	1685	1854	2022	2191	2359	2528	2696	2865	3033	3202	3370	3539	3707	3876	4044	4213		
Bucket Fill Factors		115% 110% 105% 100% 95%																					

Material Density		kg/m ³	700	800	900	1000	1100	1200	1300	1400	1500	1600	1700	1800	1900	2000	2100	2200	2300	2400	2500		
High Lift Linkage	Pin On	General Purpose	5.40 m ³ (7.06 yd ³)									6.21 m ³ (8.12 yd ³)			5.40 m ³ (7.06 yd ³)								
		Rock	4.40 m ³ (5.75 yd ³)										5.06 m ³ (6.62 yd ³)				4.40 m ³ (5.75 yd ³)						
		Coal	8.20 m ³ (10.73 yd ³)			9.43 m ³ (12.33 yd ³)			8.20 m ³ (10.73 yd ³)														
Material Density		lb/yd ³	1180	1348	1517	1685	1854	2022	2191	2359	2528	2696	2865	3033	3202	3370	3539	3707	3876	4044	4213		
Bucket Fill Factors		115% 110% 105% 100% 95%																					

Material Density		kg/m ³	700	800	900	1000	1100	1200	1300	1400	1500	1600	1700	1800	1900	2000	2100	2200	2300	2400	2500		
Aggregate Package Linkage	Pin On	General Purpose	5.70 m ³ (7.46 yd ³)										6.56 m ³ (8.58 yd ³)										
		Material Handling	6.00 m ³ (7.85 yd ³)											6.90 m ³ (9.02 yd ³)									
		Material Handling	5.70 m ³ (7.46 yd ³)												6.56 m ³ (8.58 yd ³)								
Material Density		lb/yd ³	1180	1348	1517	1685	1854	2022	2191	2359	2528	2696	2865	3033	3202	3370	3539	3707	3876	4044	4213		
Bucket Fill Factors		115% 110% 105% 100% 95%																					

NOTE: All buckets are showing Bolt-On Edges. Material Handling buckets are flat floor buckets. Contact your local Cat dealer for product availability.

950 GC

Material Density		kg/m ³	700	800	900	1000	1100	1200	1300	1400	1500	1600	1700	1800	1900	2000	2100	2200	2300	2400	2500			
Standard Linkage	General Purpose	Pin On	2.70 m ³																					
			3.10 m ³																					
			3.30 m ³																					
			3.40 m ³																					
			3.60 m ³																					
	Hook On	3.10 m ³																						
Material Handling	Pin On	4.40 m ³																						
Bucket Fill Factors		115% 110% 105% 100% 95% 																						

NOTE: All buckets are showing Bolt-On Edges.
Machine and bucket availability varies by region. Contact your local Cat dealer for product availability.

950H

Material Density		kg/m ³	700	800	900	1000	1100	1200	1300	1400	1500	1600	1700	1800	1900	2000	2100	2200	2300	2400	2500	
Standard Linkage	Pin On	General Purpose	2.70 m ³ (3.53 yd ³)												3.11 m ³ (4.07 yd ³)						2.70 m ³ (3.53 yd ³)	
			3.10 m ³ (4.05 yd ³)											3.57 m ³ (4.67 yd ³)								3.10 m ³ (4.05 yd ³)
			3.40 m ³ (4.45 yd ³)											3.91 m ³ (5.11 yd ³)								3.40 m ³ (4.45 yd ³)
	Material Handling	3.20 m ³ (4.19 yd ³)														3.68 m ³ (4.81 yd ³)						3.20 m ³ (4.19 yd ³)
		3.40 m ³ (4.45 yd ³)														3.91 m ³ (5.11 yd ³)						3.40 m ³ (4.45 yd ³)
		3.60 m ³ (4.71 yd ³)														4.14 m ³ (5.41 yd ³)						3.60 m ³ (4.71 yd ³)
High Lift Linkage	Pin On	General Purpose	2.70 m ³ (3.53 yd ³)												3.11 m ³ (4.07 yd ³)						2.70 m ³ (3.53 yd ³)	
			3.10 m ³ (4.05 yd ³)													3.57 m ³ (4.67 yd ³)						3.10 m ³ (4.05 yd ³)
			3.40 m ³ (4.45 yd ³)														3.91 m ³ (5.11 yd ³)					
	Material Handling	3.20 m ³ (4.19 yd ³)														3.68 m ³ (4.81 yd ³)						3.20 m ³ (4.19 yd ³)
		3.40 m ³ (4.45 yd ³)														3.91 m ³ (5.11 yd ³)						3.40 m ³ (4.45 yd ³)
		3.60 m ³ (4.71 yd ³)														4.14 m ³ (5.41 yd ³)						3.60 m ³ (4.71 yd ³)
Material Density		lb/yd ³	1180	1348	1517	1685	1854	2022	2191	2359	2528	2696	2865	3033	3202	3370	3539	3707	3876	4044	4213	
Bucket Fill Factors		115% 110% 105% 100% 95%																				

NOTE: All buckets are showing Bolt-On Edges.

962H

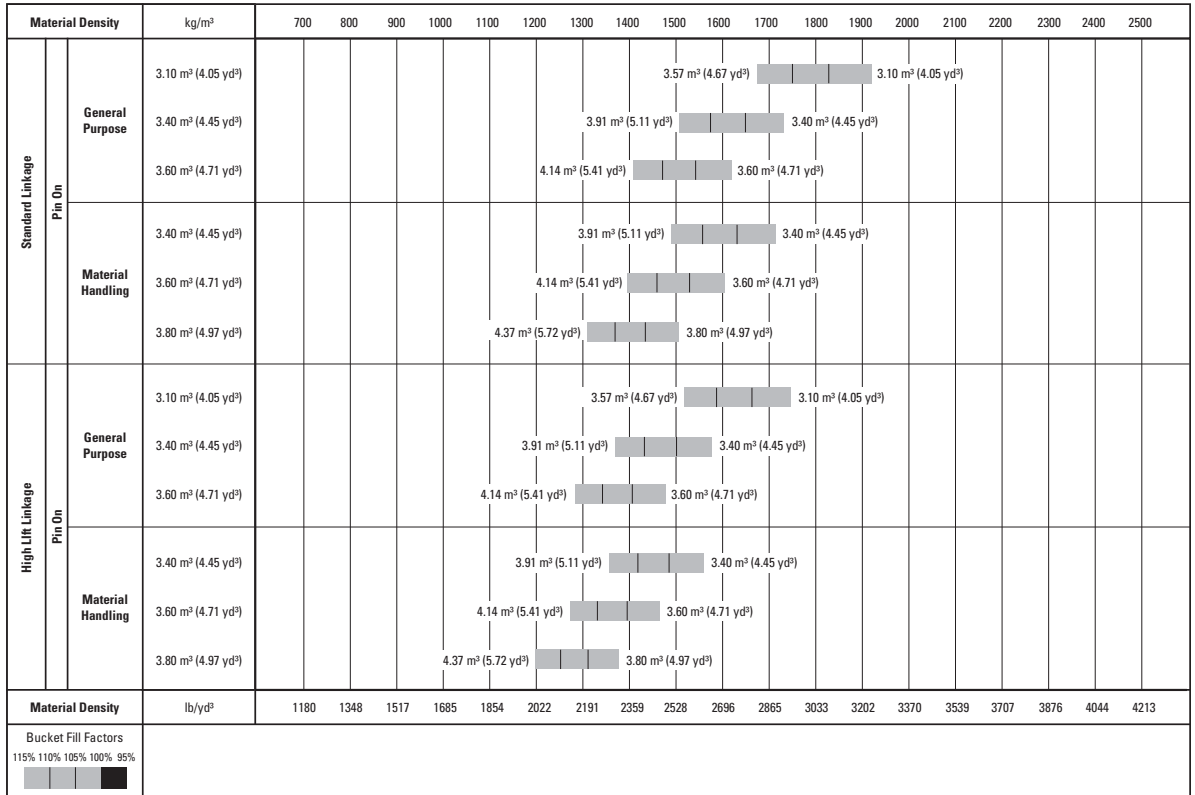

NOTE: All buckets are showing Bolt-On Edges.

966H

Material Density		kg/m ³	700	800	900	1000	1100	1200	1300	1400	1500	1600	1700	1800	1900	2000	2100	2200	2300	2400		
Standard Linkage	Pin On	General Purpose	3.80 m ³ (4.97 yd ³)											4.37 m ³ (5.72 yd ³)							3.80 m ³ (4.97 yd ³)	
			4.00 m ³ (5.23 yd ³)												4.60 m ³ (6.02 yd ³)							4.00 m ³ (5.23 yd ³)
			4.20 m ³ (5.49 yd ³)												4.83 m ³ (6.32 yd ³)							4.20 m ³ (5.49 yd ³)
			4.60 m ³ (6.02 yd ³)											5.29 m ³ (6.92 yd ³)								4.60 m ³ (6.02 yd ³)
	Rock	3.40 m ³ (4.45 yd ³)												3.91 m ³ (5.11 yd ³)							3.40 m ³ (4.45 yd ³)	
		4.00 m ³ (5.23 yd ³)												4.60 m ³ (6.02 yd ³)							4.00 m ³ (5.23 yd ³)	
	Material Handling/Standard	4.00 m ³ (5.23 yd ³)													4.60 m ³ (6.02 yd ³)							4.00 m ³ (5.23 yd ³)
		4.60 m ³ (6.02 yd ³)												5.29 m ³ (6.92 yd ³)							4.60 m ³ (6.02 yd ³)	
Material Density		lb/yd ³	1180	1348	1517	1685	1854	2022	2191	2359	2528	2696	2865	3033	3202	3370	3539	3707	3876	4044		
Bucket Fill Factors		115% 110% 105% 100% 95%																				

NOTE: All buckets are showing Bolt-On Edges.

972H

Material Density		kg/m ³	700	800	900	1000	1100	1200	1300	1400	1500	1600	1700	1800	1900	2000	2100	2200	2300	2400			
Standard Linkage	Pin On	General Purpose	4.20 m ³ (5.49 yd ³)											4.83 m ³ (6.32 yd ³)							4.20 m ³ (5.49 yd ³)		
			4.60 m ³ (6.02 yd ³)									5.29 m ³ (6.92 yd ³)											4.60 m ³ (6.02 yd ³)
		Material Handling	4.60 m ³ (6.02 yd ³)									5.29 m ³ (6.92 yd ³)											4.60 m ³ (6.02 yd ³)
			4.00 m ³ (5.23 yd ³)									4.60 m ³ (6.02 yd ³)											4.00 m ³ (5.23 yd ³)
	Material Handling/Standard	4.60 m ³ (6.02 yd ³)									5.29 m ³ (6.92 yd ³)											4.60 m ³ (6.02 yd ³)	
		5.00 m ³ (6.54 yd ³)									5.75 m ³ (7.52 yd ³)											5.00 m ³ (6.54 yd ³)	
	Material Density		lb/yd ³	1180	1348	1517	1685	1854	2022	2191	2359	2528	2696	2865	3033	3202	3370	3539	3707	3876	4044		
	Bucket Fill Factors			115% 110% 105% 100% 95% 																			

NOTE: All buckets are showing Bolt-On Edges.

980H

Material Density		kg/m ³	700	800	900	1000	1100	1200	1300	1400	1500	1600	1700	1800	1900	2000	2100	2200	2300	2400		
Standard Linkage Pin On	General Purpose	5.40 m ³ (5.70 yd ³)																				
		5.70 m ³ (7.46 yd ³)																				
		6.00 m ³ (7.85 yd ³)																				
	Material Handling	5.70 m ³ (7.46 yd ³)																				
	Rock	4.40 m ³ (5.75 yd ³)																				
	Coal	8.20 m ³ (10.73 yd ³)																				
General Purpose/ Heavy Duty	5.70 m ³ (7.46 yd ³)																					
Material Density		lb/yd ³	1180	1348	1517	1685	1854	2022	2191	2359	2528	2696	2865	3033	3202	3370	3539	3707	3876	4044		
Bucket Fill Factors 115% 110% 105% 100% 95%																						

NOTE: All buckets are showing Bolt-On Edges.

986H — Standard Lift

Material Density				Bucket Volume	
kg/m ³	tonnes/m ³	lb/yd ³	tons/yd ³	m ³	yd ³
1632-1795	1.63-1.80	2750-3025	1.38-1.51	6.1	8
1740-1914	1.74-1.91	2933-3227	1.46-1.61	5.7	7.5
1865-2051	1.86-2.05	3143-3457	1.57-1.73	5.4	7

*Density range covers 100% rated payload to 110% rated payload in accordance with Large Wheel Loader payload policy.

988K

Material Density				Bucket Volume	
kg/m ³	tonnes/m ³	lb/yd ³	tons/yd ³	m ³	yd ³
1468-1614	1.47-1.61	2500-2750	1.25-1.38	7.7	10
1638-1801	1.64-1.80	2778-3056	1.39-1.53	6.9	9
1766-1942	1.77-1.94	3001-3300	1.50-1.65	6.4	8.33

990K

Material Density				Bucket Volume	
kg/m ³	tonnes/m ³	lb/yd ³	tons/yd ³	m ³	yd ³
1590-1749	1.59-1.75	2692-2962	1.35-1.48	10	13
1728-1901	1.73-1.90	2917-3208	1.46-1.60	9.2	12
1849-2034	1.85-2.03	3111-3422	1.56-1.71	8.6	11.25

992K — Standard

Up to specified density for 100% fill factor

Bucket Volume		Material Density	
m ³	yd ³	kg/m ³	lb/yd ³
12.2	16	1780	3000
11.5	15	1890	3200
10.7	14	2030	3430

992K — High Lift

Up to specified density for 100% fill factor

Bucket Volume		Material Density	
m ³	yd ³	kg/m ³	lb/yd ³
12.2	16	1560	2630
11.5	15	1560	2630
10.7	14	1560	2630

993K — Standard

Up to specified density for 100% fill factor

Bucket Volume		Material Density	
m ³	yd ³	kg/m ³	lb/yd ³
15.3	20	1780	3000
14.5	19	1870	3160
13.8	18	1970	3330

993K — High Lift

Up to specified density for 100% fill factor

Bucket Volume		Material Density	
m ³	yd ³	kg/m ³	lb/yd ³
14.5	19	1720	2890
13.8	18	1810	3060
13.0	17	1920	3240

994K Standard Lift

Bucket Type	Bucket Volume		Material Density	
	m ³	yd ³	kg/m ³	lb/yd ³
Rock	19.1	25	2138	3600
	21.4	28	1909	3215
	22.9	30	1781	3000
	24.5	32	1669	2810
HD Rock	19.1	25	2090	3520
	21.4	28	1802	3035
Coal	32.1	42	1271	2140
	39.8	52	1027	1730
Iron Ore	17.2	22.5	2286	3850

994K High Lift

Bucket Type	Bucket Volume		Material Density	
	m ³	yd ³	kg/m ³	lb/yd ³
Rock	19.1	25	1995	3360
	21.4	28	1781	3000
	22.9	30	1663	2800
	24.5	32	1559	2625
HD Rock	19.1	25	1900	3200
	21.4	28	1675	2820
Coal	32.1	42	1188	2000
	39.8	52	959	1615
Iron Ore	17.2	22.5	2126	3580

926M TRAVEL TIME — LOADED

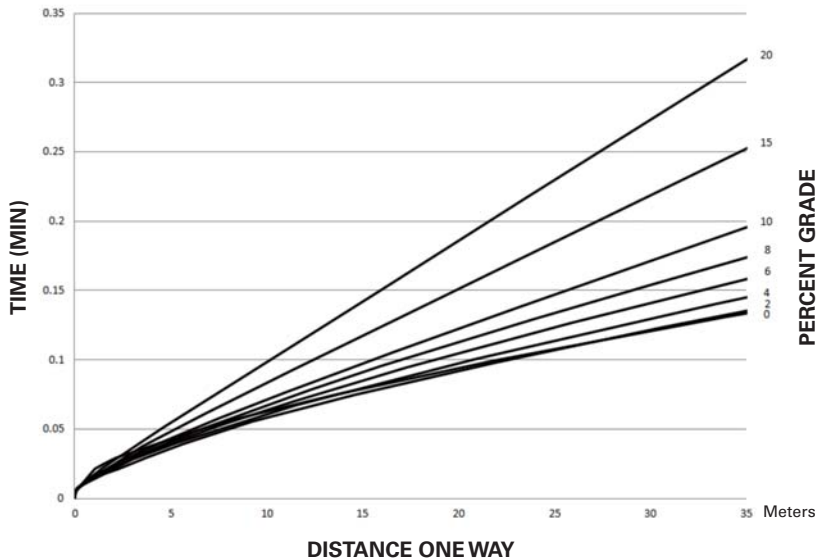
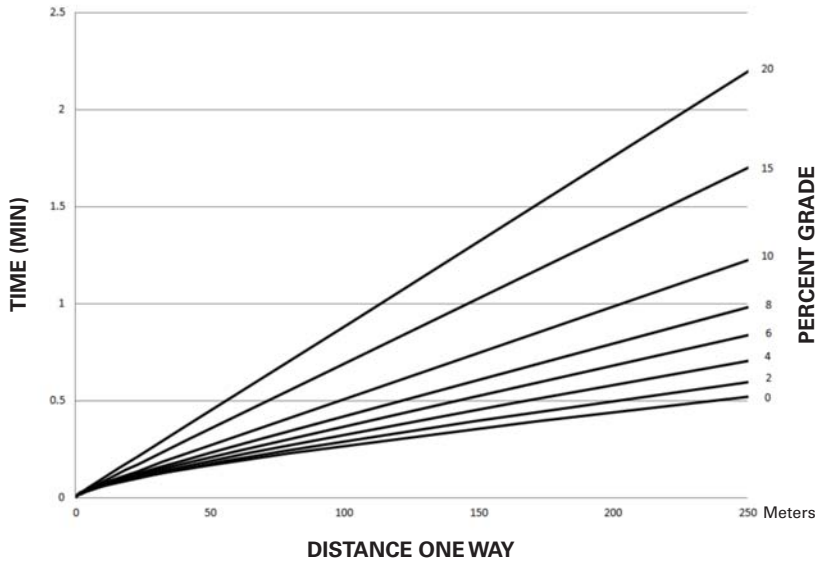

NOTE: 926M Configuration: 2.1 m³ (2.75 yd³) bucket; 1780 kg/m³ (3000 lb/yd³) material density; 105% fill factor; 13 050 kg (28,770 lb) machine mass
Meets Tier 4 Final/Stage IV/Japan 2014 (Tier 4 Final) emission standards.
Travel time assumes maximum governor pedal depression and automatic shifting in Range 4.
In load and carry applications it is important to consult the tire manufacturer on Ton-MPH ratings and pressure recommendations.

926M TRAVEL TIME — EMPTY

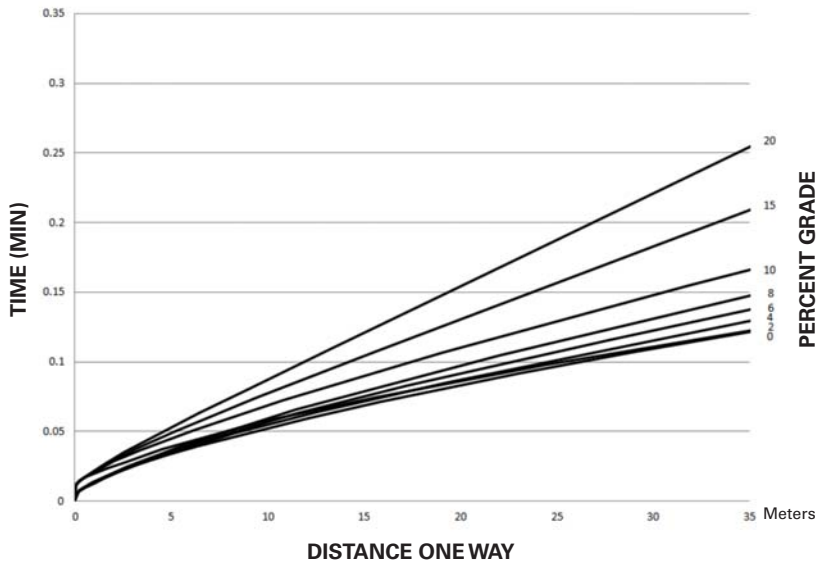
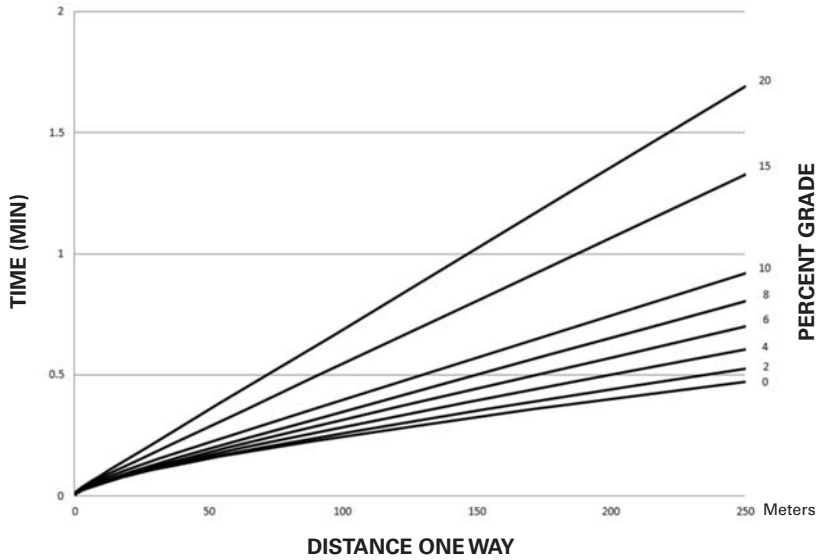

NOTE: 926M Configuration: 2.1 m³ (2.75 yd³) bucket; 1780 kg/m³ (3000 lb/yd³) material density; 105% fill factor; 13 050 kg (28,770 lb) machine mass
Meets Tier 4 Final/Stage IV/Japan 2014 (Tier 4 Final) emission standards.
Travel time assumes maximum governor pedal depression and automatic shifting in Range 4.
In load and carry applications it is important to consult the tire manufacturer on Ton-MPH ratings and pressure recommendations.

930M TRAVEL TIME — LOADED

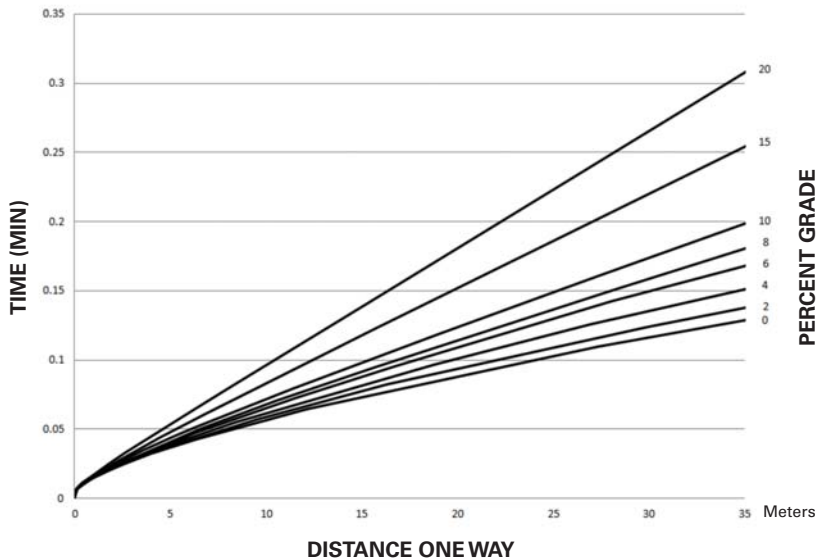
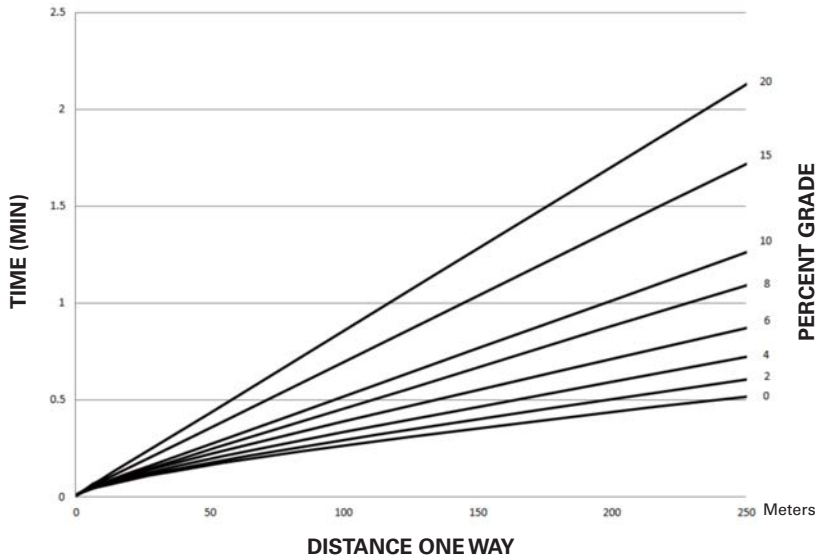

NOTE: 930M Configuration: 2.3 m³ (3.0 yd³) bucket; 1780 kg/m³ (3000 lb/yd³) material density; 105% fill factor; 14 007 kg (30,880 lb) machine mass
Meets Tier 4 Final/Stage IV/Japan 2014 (Tier 4 Final) emission standards.
Travel time assumes maximum governor pedal depression and automatic shifting in Range 4.
In load and carry applications it is important to consult the tire manufacturer on Ton-MPH ratings and pressure recommendations.

930M TRAVEL TIME — EMPTY

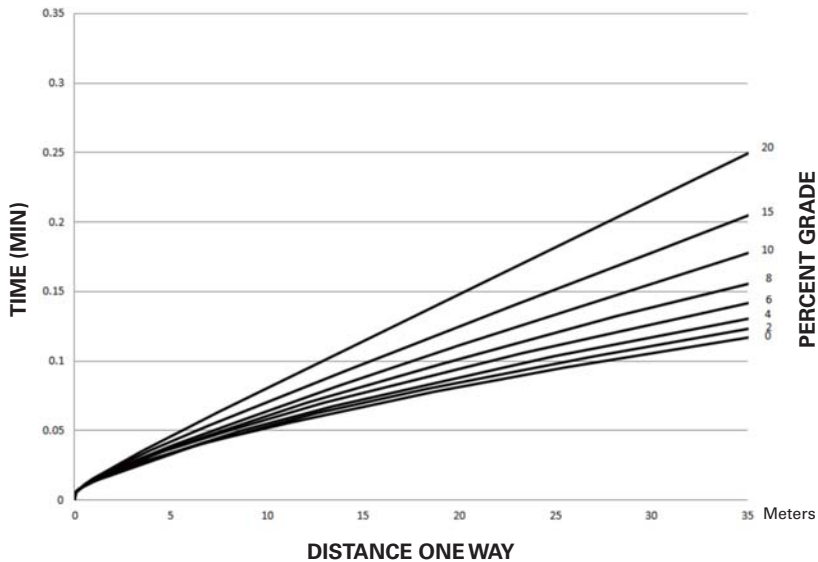
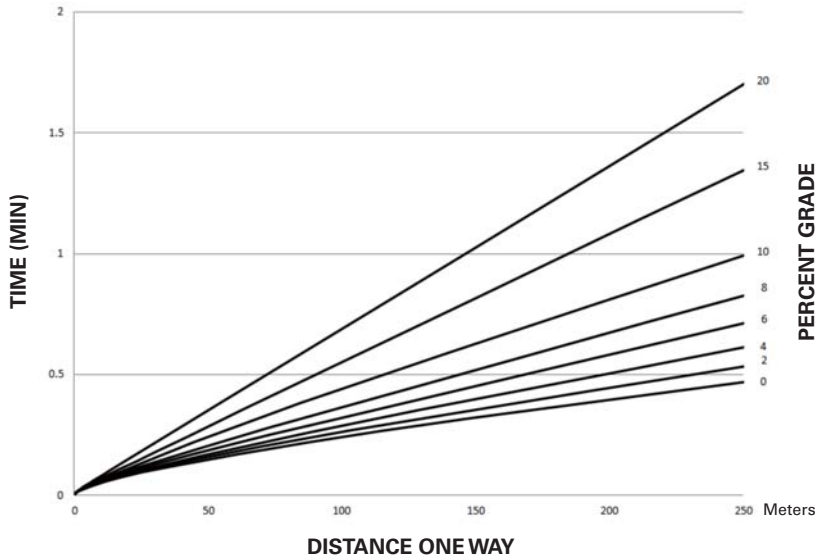

NOTE: 930M Configuration: 2.3 m³ (3.5 yd³) bucket; 1780 kg/m³ (3000 lb/yd³) material density; 105% fill factor; 14,007 kg (34,017 lb) machine mass
Meets Tier 4 Final/Stage IV/Japan 2014 (Tier 4 Final) emission standards.
Travel time assumes maximum governor pedal depression and automatic shifting in Range 4.
In load and carry applications it is important to consult the tire manufacturer on Ton-MPH ratings and pressure recommendations.

938M TRAVEL TIME — LOADED

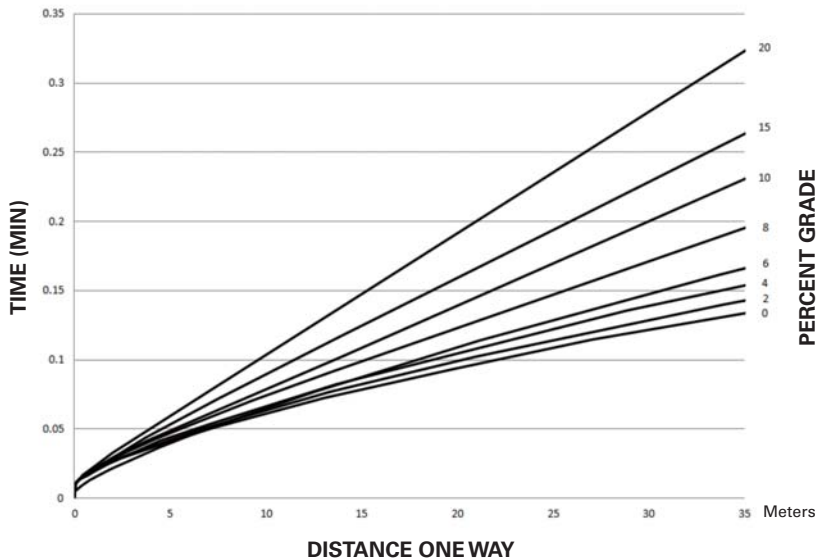
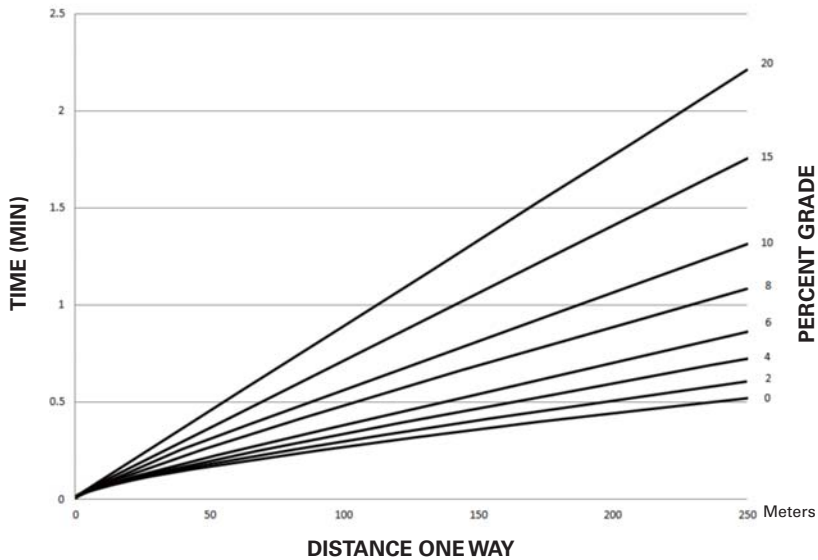

NOTE: 938M Configuration: 2.7 m³ (3.5 yd³) bucket; 1780 kg/m³ (3000 lb/yd³) material density; 105% fill factor; 16 427 kg (36,215 lb) machine mass
Meets Tier 4 Final/Stage IV/Japan 2014 (Tier 4 Final) emission standards.
Travel time assumes maximum governor pedal depression and automatic shifting in Range 4.
In load and carry applications it is important to consult the tire manufacturer on Ton-MPH ratings and pressure recommendations.

938M TRAVEL TIME — EMPTY

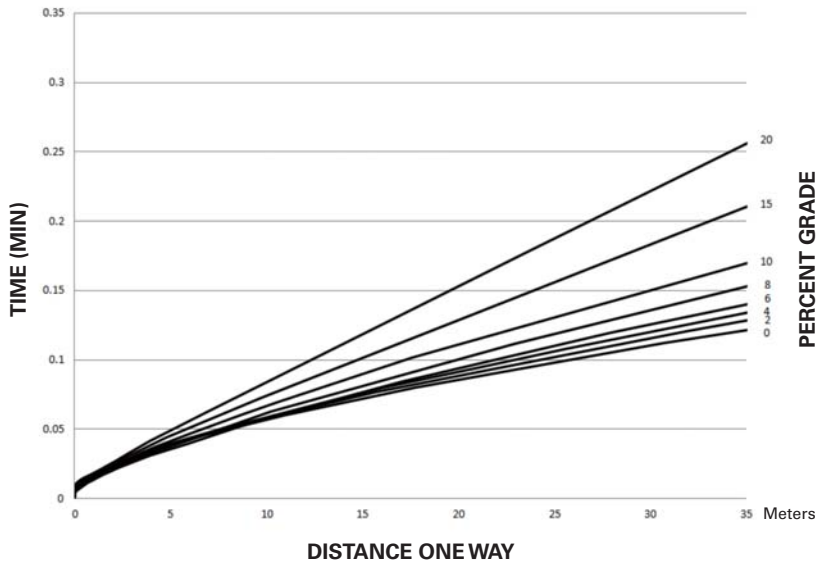
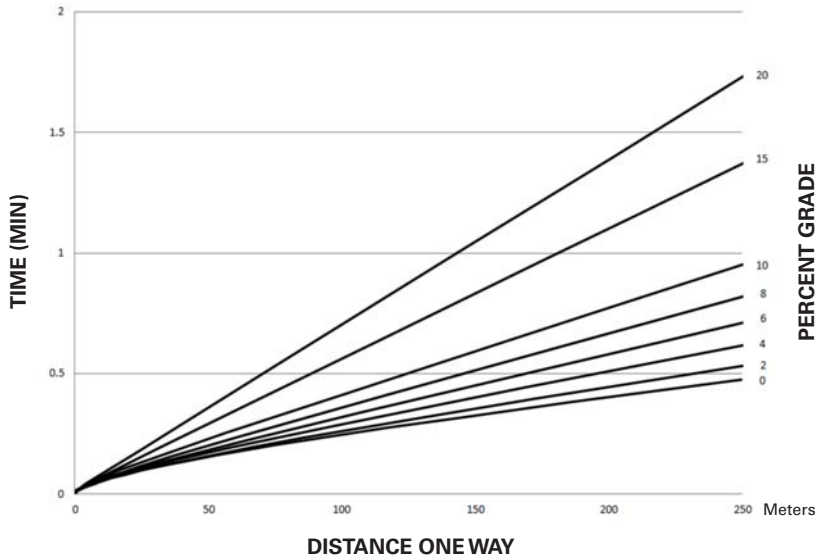

NOTE: 938M Configuration: 2.7 m³ (3.5 yd³) bucket; 1780 kg/m³ (3000 lb/yd³) material density; 105% fill factor; 16 427 kg (36,215 lb) machine mass
Meets Tier 4 Final/Stage IV/Japan 2014 (Tier 4 Final) emission standards.
Travel time assumes maximum governor pedal depression and automatic shifting in Range 4.
In load and carry applications it is important to consult the tire manufacturer on Ton-MPH ratings and pressure recommendations.

924K TRAVEL TIME — LOADED

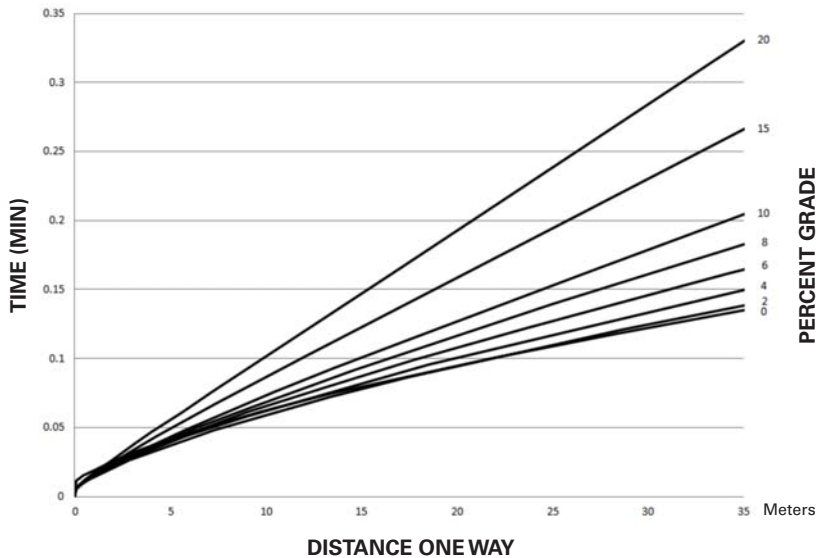
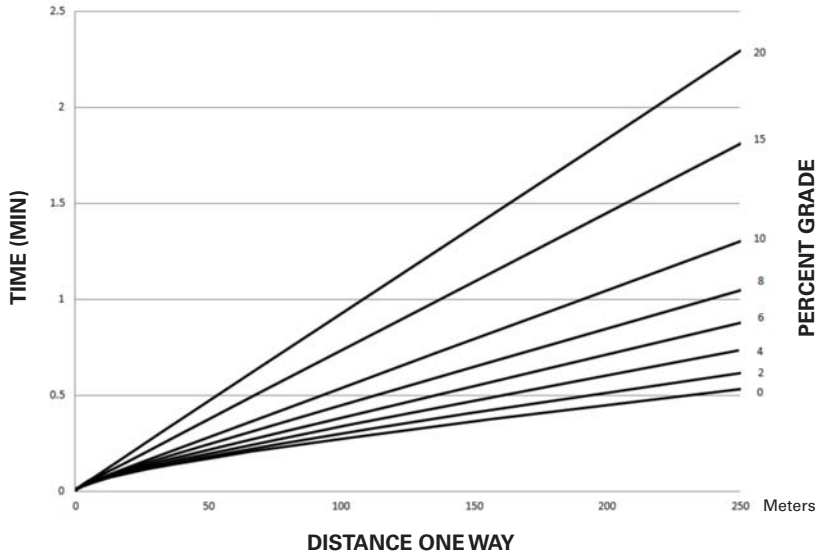

NOTE: 924K Configuration: 2.1 m³ (2.75 yd³) bucket; 1780 kg/m³ (3000 lb/yd³) material density; 105% fill factor; 11 966 kg (26,380 lb) machine mass
Travel time assumes maximum governor pedal depression and automatic shifting in Range 4.
In load and carry applications it is important to consult the tire manufacturer on Ton-MPH ratings and pressure recommendations.

924K TRAVEL TIME — EMPTY

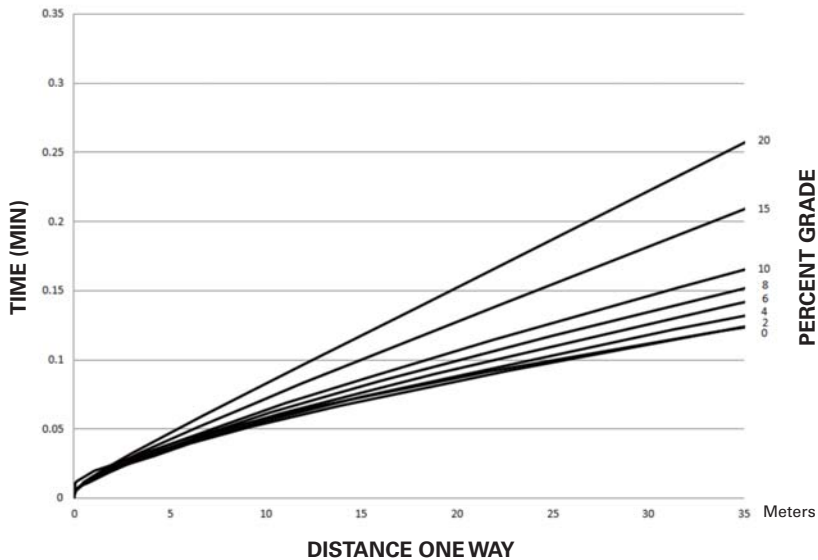
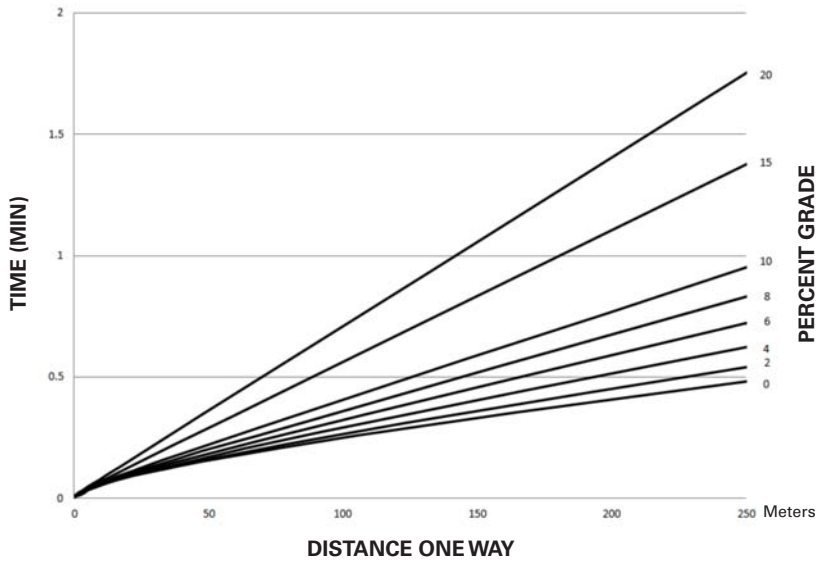

NOTE: 924K Configuration: 2.1 m³ (2.75 yd³) bucket; 1780 kg/m³ (3000 lb/yd³) material density; 105% fill factor; 11 966 kg (26,380 lb) machine mass
 Travel time assumes maximum governor pedal depression and automatic shifting in Range 4.
 In load and carry applications it is important to consult the tire manufacturer on Ton-MPH ratings and pressure recommendations.

930K TRAVEL TIME — LOADED

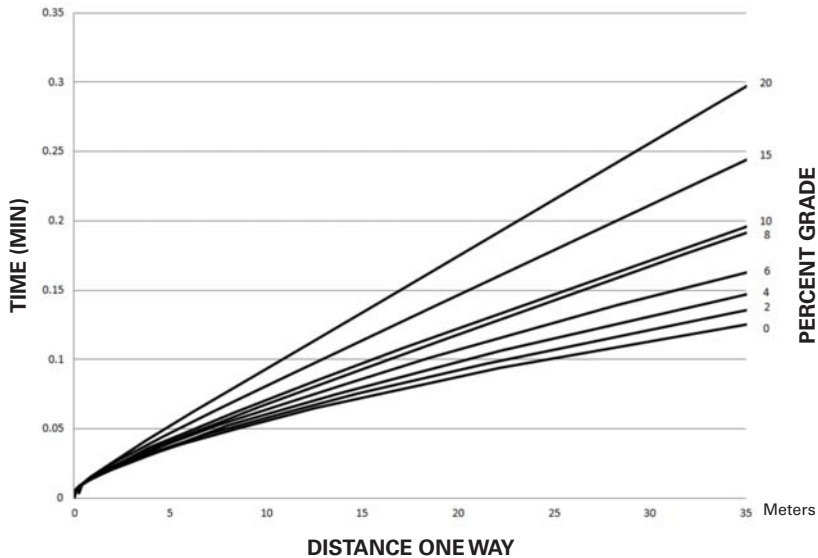
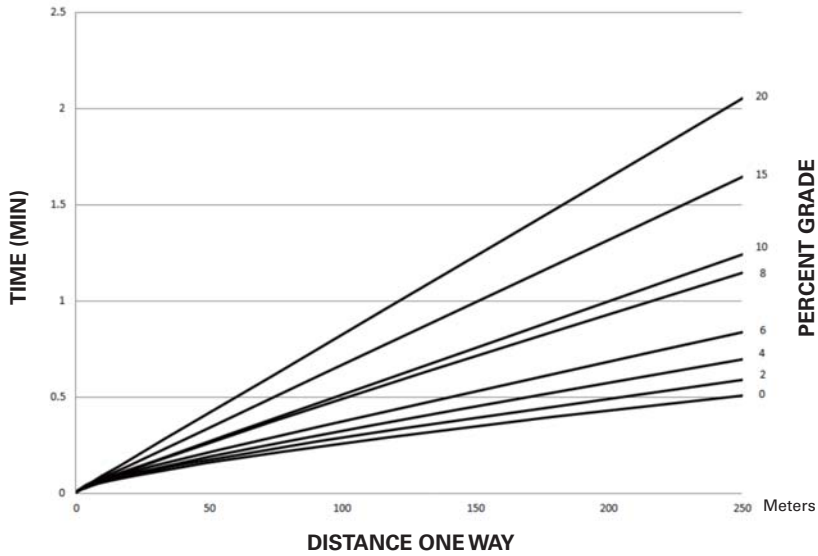

NOTE: 930K Configuration: 2.3 m³ (3.0 yd³) bucket; 1780 kg/m³ (3000 lb/yd³) material density; 105% fill factor; 13 135 kg (28,957 lb) machine mass
Travel time assumes maximum governor pedal depression and automatic shifting in Range 4.
In load and carry applications it is important to consult the tire manufacturer on Ton-MPH ratings and pressure recommendations.

930K TRAVEL TIME — EMPTY

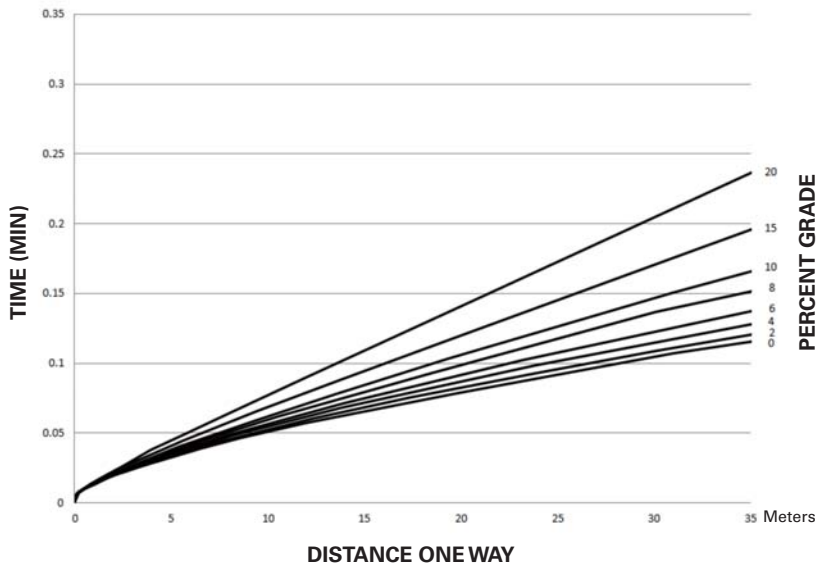
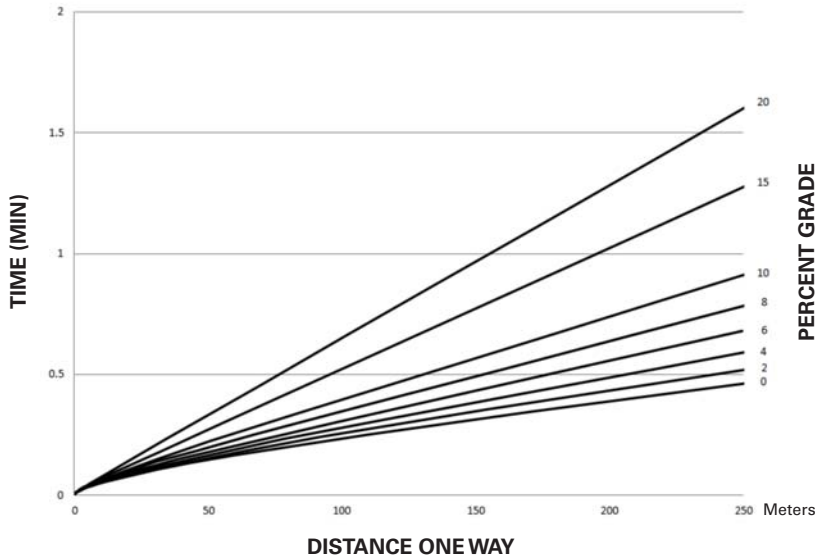

NOTE: 930K Configuration: 2.3 m³ (3.0 yd³) bucket; 1780 kg/m³ (3000 lb/yd³) material density; 105% fill factor; 13 135 kg (28,957 lb) machine mass
Travel time assumes maximum governor pedal depression and automatic shifting in Range 4.
In load and carry applications it is important to consult the tire manufacturer on Ton-MPH ratings and pressure recommendations.

938K TRAVEL TIME — LOADED

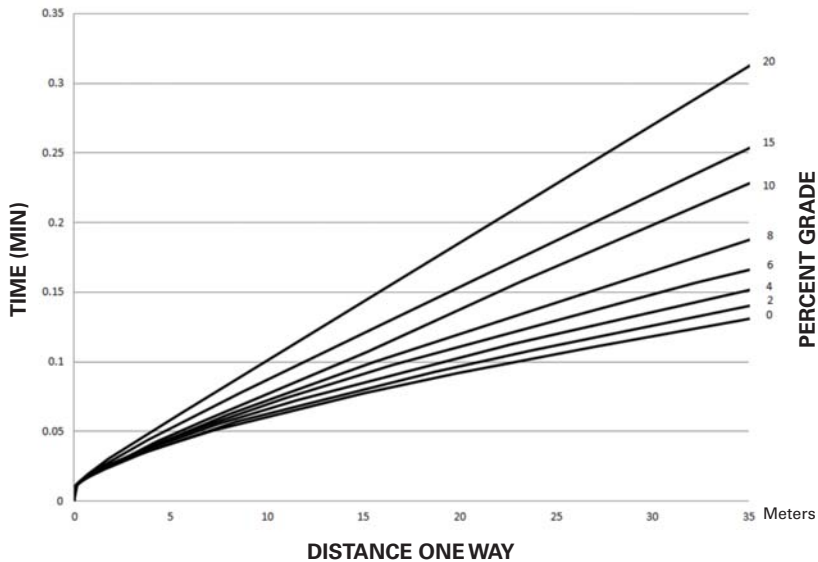
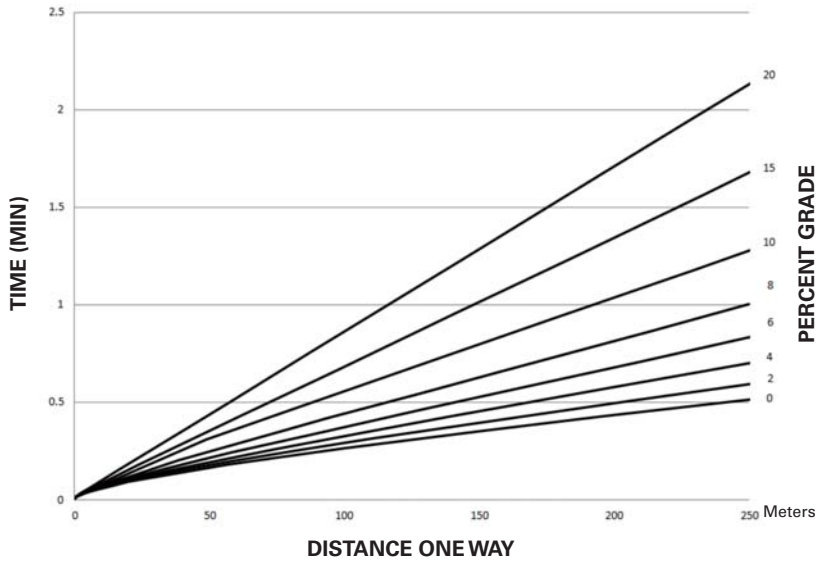

NOTE: 938K Configuration: 2.7 m³ (3.5 yd³) bucket; 1780 kg/m³ (3000 lb/yd³) material density; 105% fill factor; 15 430 kg (34,017 lb) machine mass
Travel time assumes maximum governor pedal depression and automatic shifting in Range 4.
In load and carry applications it is important to consult the tire manufacturer on Ton-MPH ratings and pressure recommendations.

938K TRAVEL TIME — EMPTY

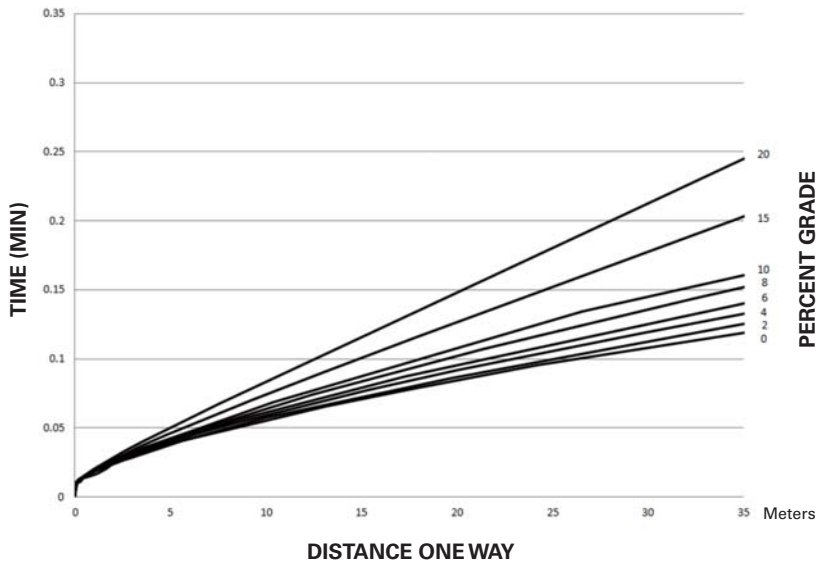
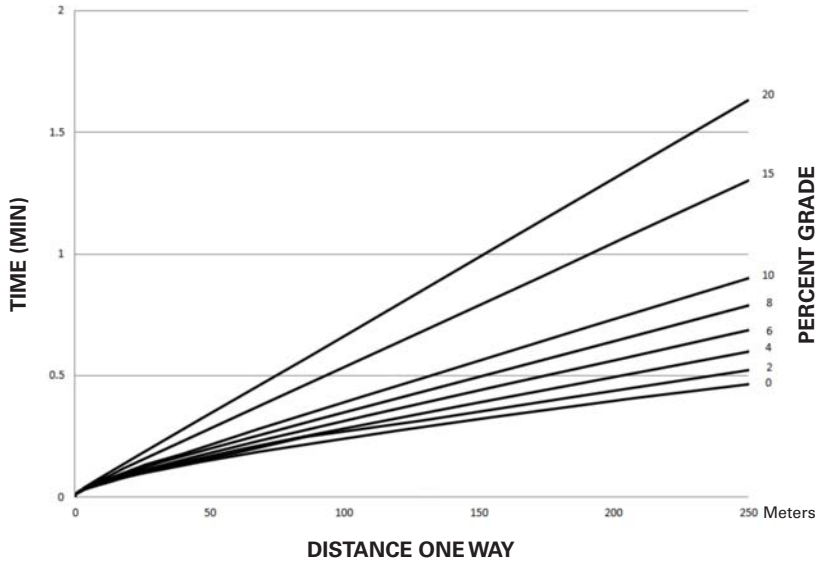

NOTE: 938K Configuration: 2.7 m³ (3.5 yd³) bucket; 1780 kg/m³ (3000 lb/yd³) material density; 105% fill factor; 15 430 kg (34,017 lb) machine mass
Travel time assumes maximum governor pedal depression and automatic shifting in Range 4.
In load and carry applications it is important to consult the tire manufacturer on Ton-MPH ratings and pressure recommendations.

Wheel Loaders Integrated Toolcarriers

Travel Time — Loaded and Empty

- 950M
- 23.5R25 Tires

950M TRAVEL TIME — LOADED

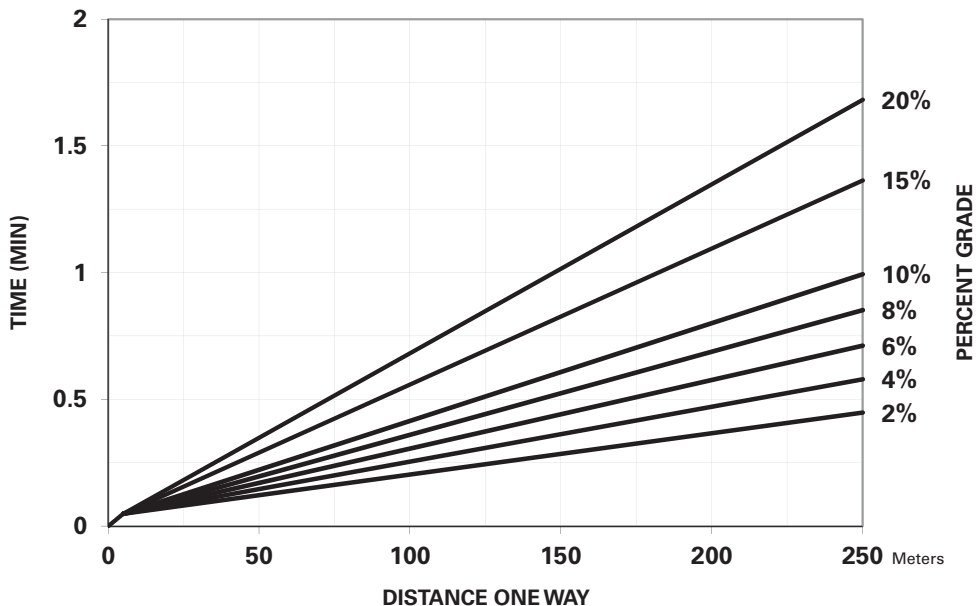

950M TRAVEL TIME — EMPTY

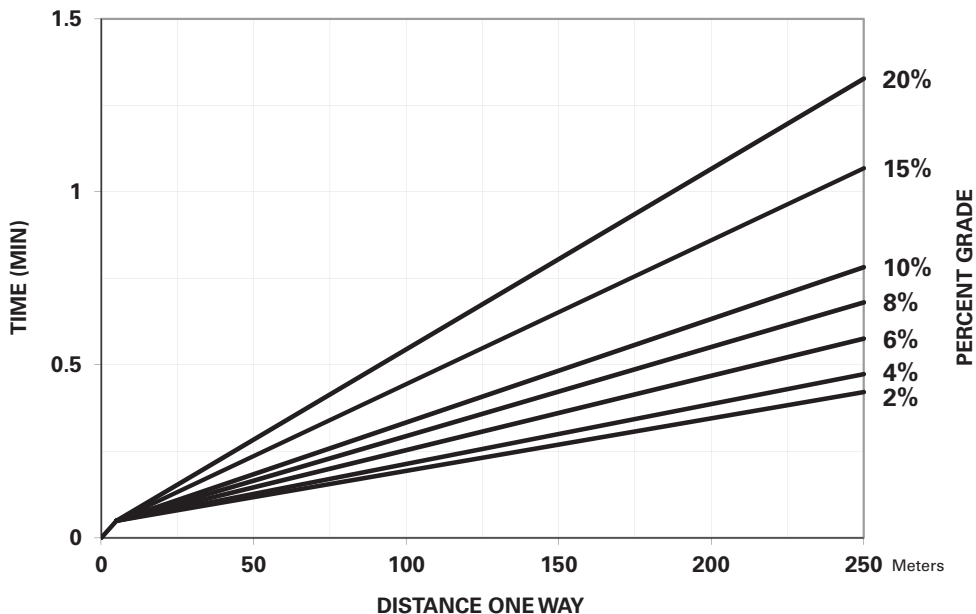

Curves assume use of highest operating speed attainable.

In load-and-carry applications it is important to consult the tire manufacturer on load-speed ratings and pressure recommendations.

962M TRAVEL TIME — LOADED

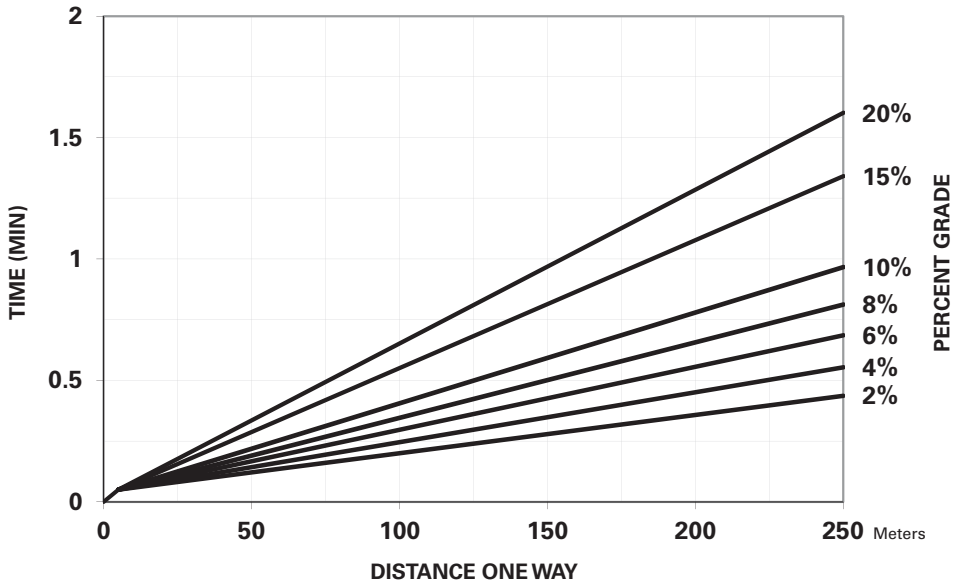

962M TRAVEL TIME — EMPTY

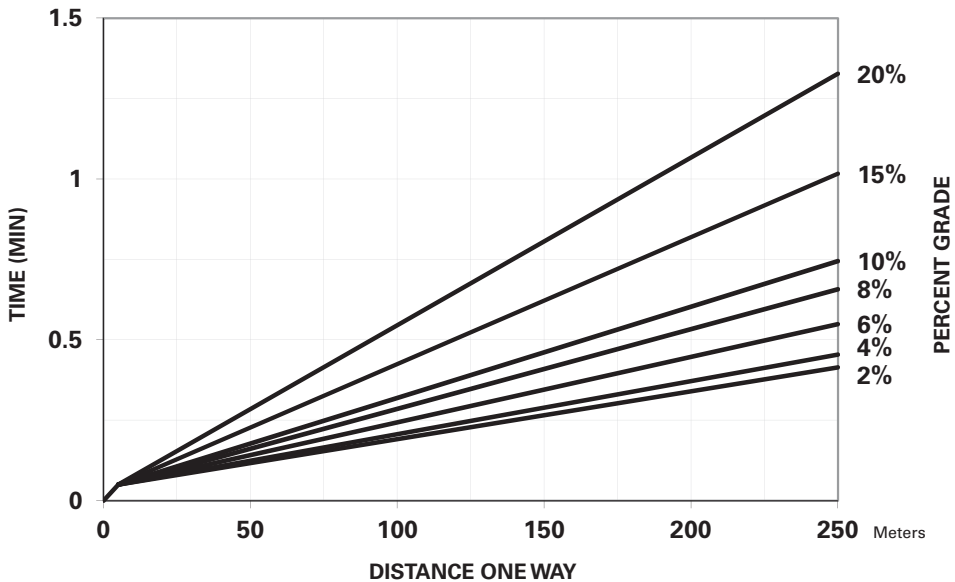

Curves assume use of highest operating speed attainable.

In load-and-carry applications it is important to consult the tire manufacturer on load-speed ratings and pressure recommendations.

Wheel Loaders Integrated Toolcarriers

Travel Time — Loaded and Empty

- 966M
- 26.5R25 Tires

966M TRAVEL TIME — LOADED

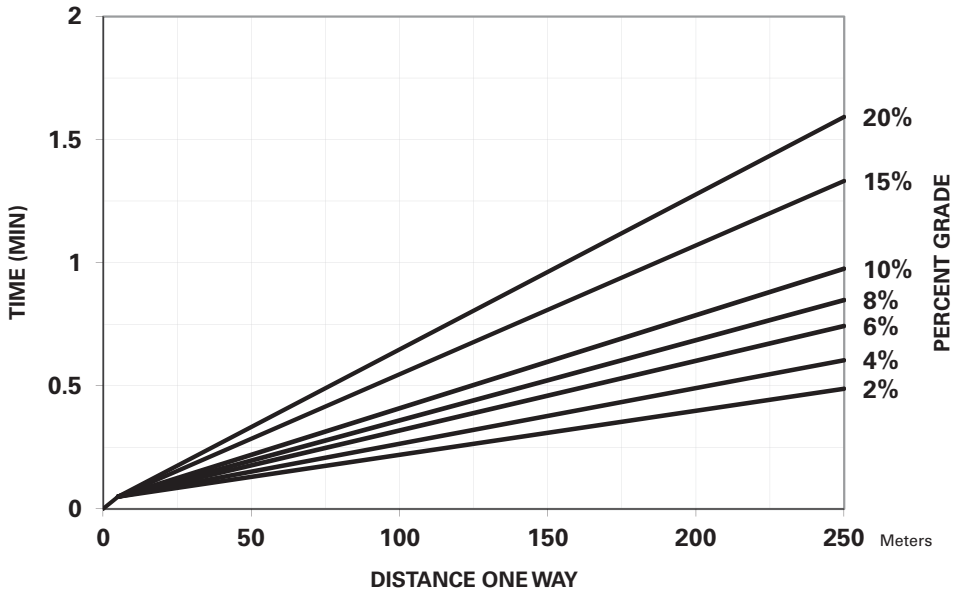

966M TRAVEL TIME — EMPTY

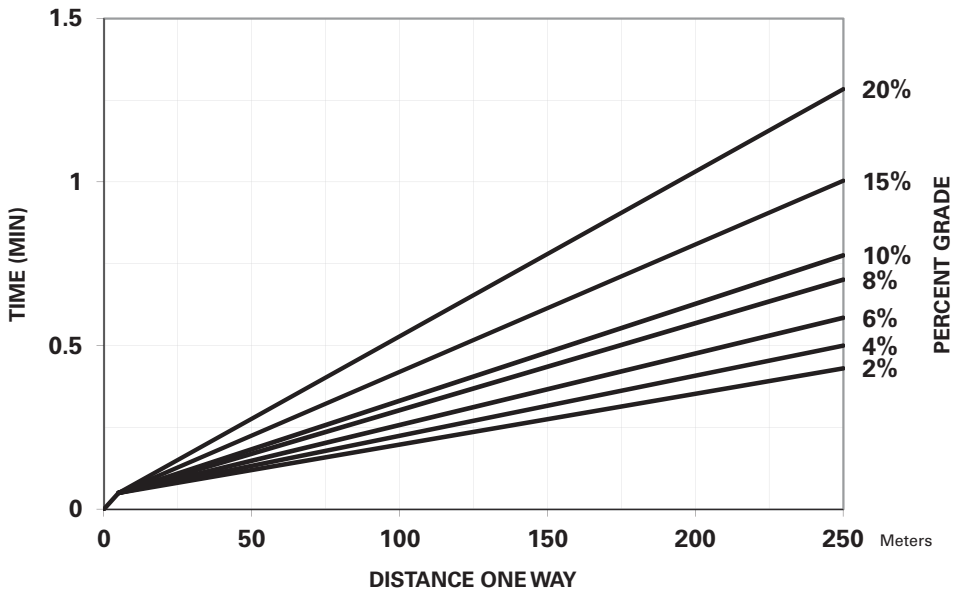

Curves assume use of highest operating speed attainable.

In load-and-carry applications it is important to consult the tire manufacturer on load-speed ratings and pressure recommendations.

972M TRAVEL TIME — LOADED

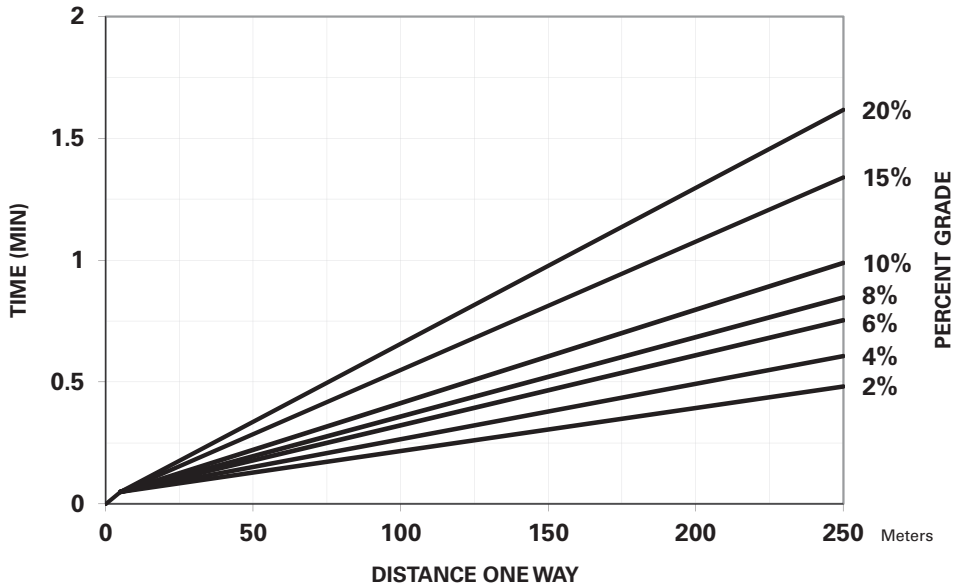

972M TRAVEL TIME — EMPTY

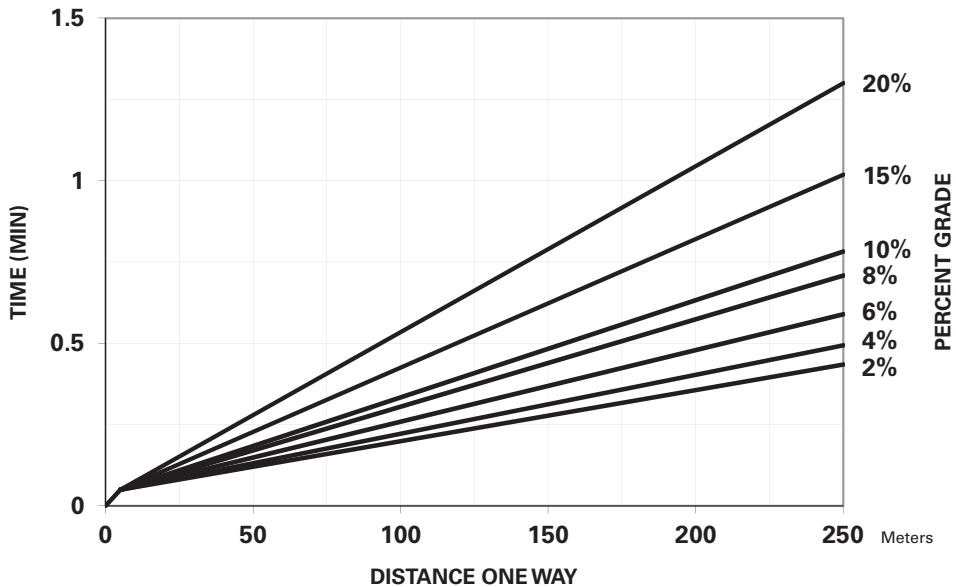

Curves assume use of highest operating speed attainable.

In load-and-carry applications it is important to consult the tire manufacturer on load-speed ratings and pressure recommendations.

Wheel Loaders Integrated Toolcarriers

Travel Time — Loaded and Empty

- 980M
- 29.5R25 L4 Tires

980M TRAVEL TIME — LOADED

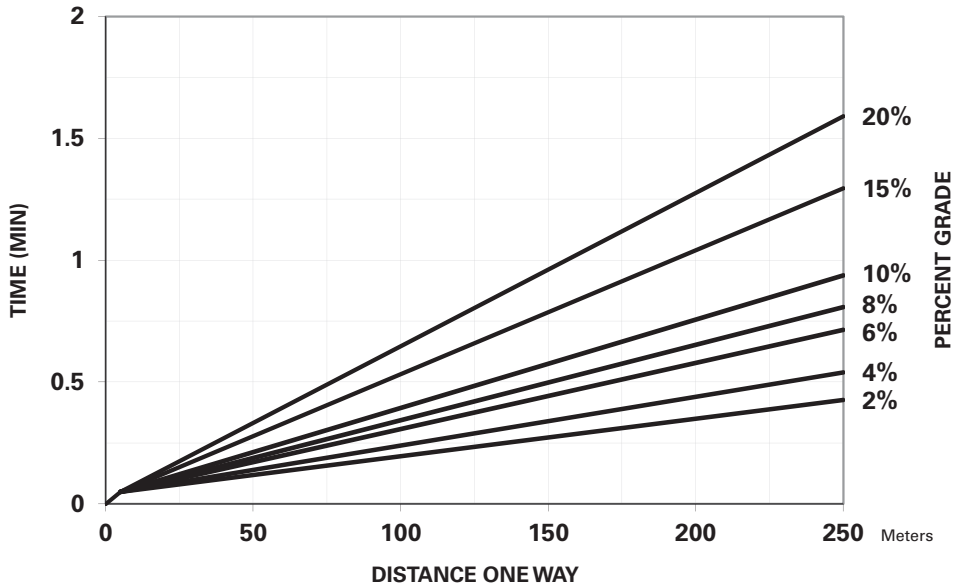

980M TRAVEL TIME — EMPTY

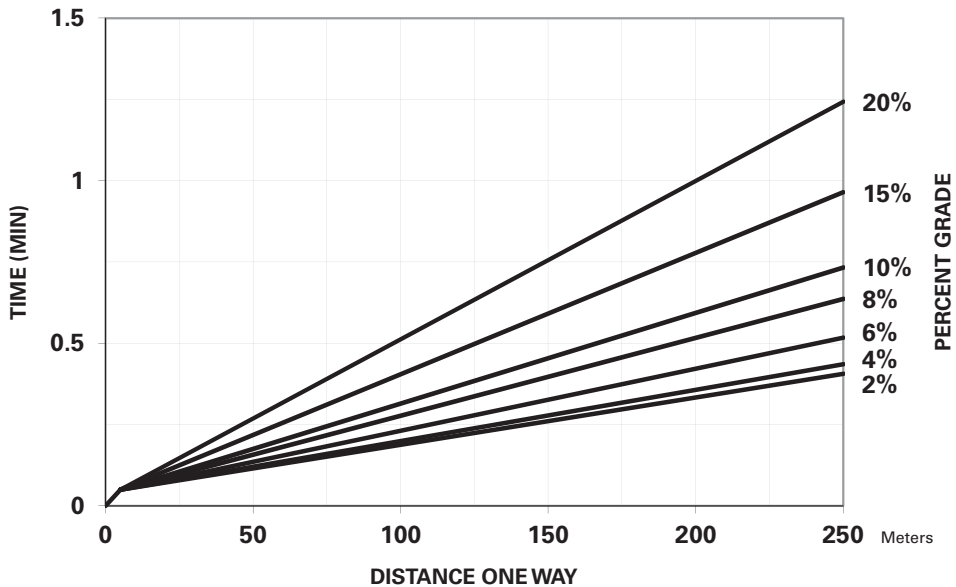

Curves assume use of highest operating speed attainable.

In load-and-carry applications it is important to consult the tire manufacturer on load-speed ratings and pressure recommendations.

982M TRAVEL TIME — LOADED

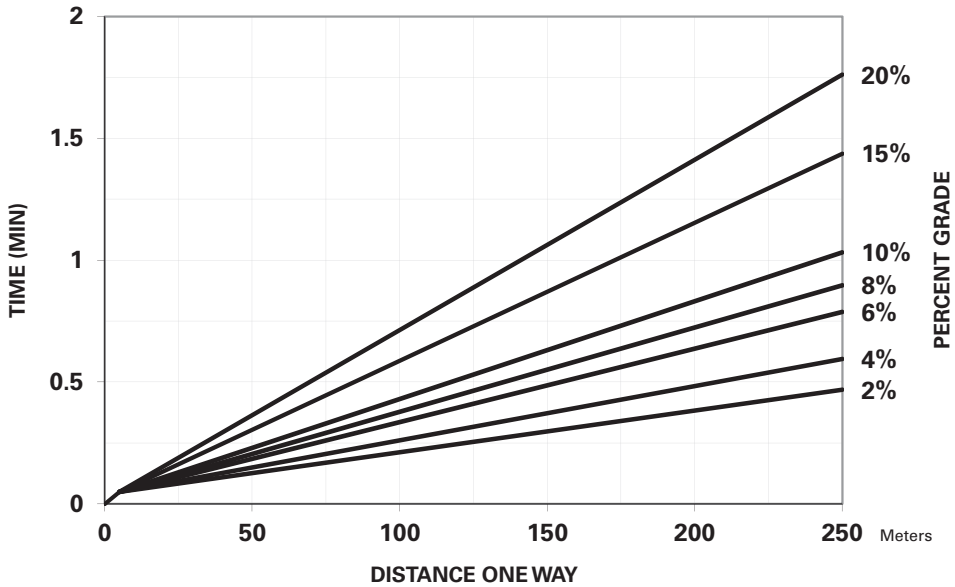

982M TRAVEL TIME — EMPTY

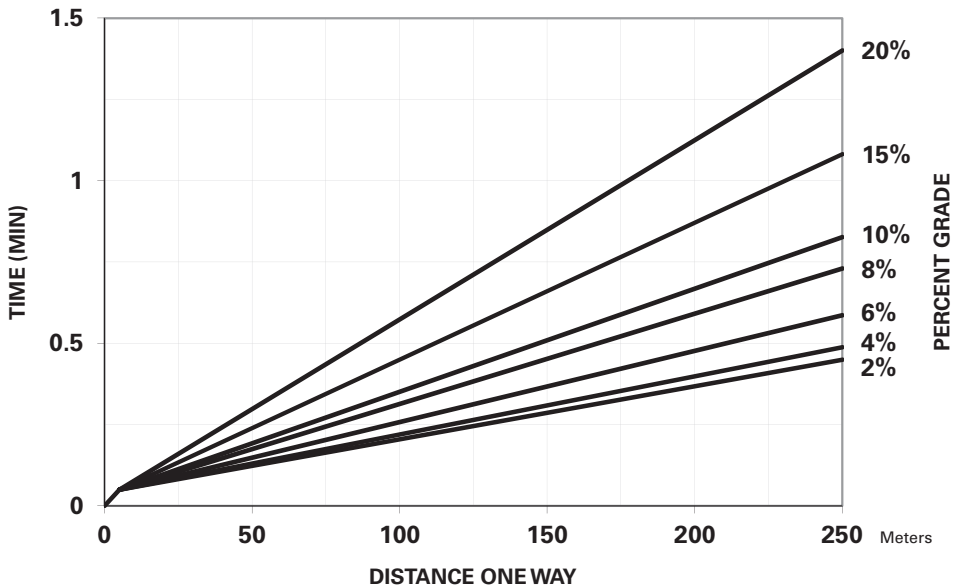

Curves assume use of highest operating speed attainable.

In load-and-carry applications it is important to consult the tire manufacturer on load-speed ratings and pressure recommendations.

**Wheel Loaders
Integrated Toolcarriers**

Travel Time — Loaded and Empty

- 950K
- 23.5-R25 Tires

950K TRAVEL TIME — LOADED

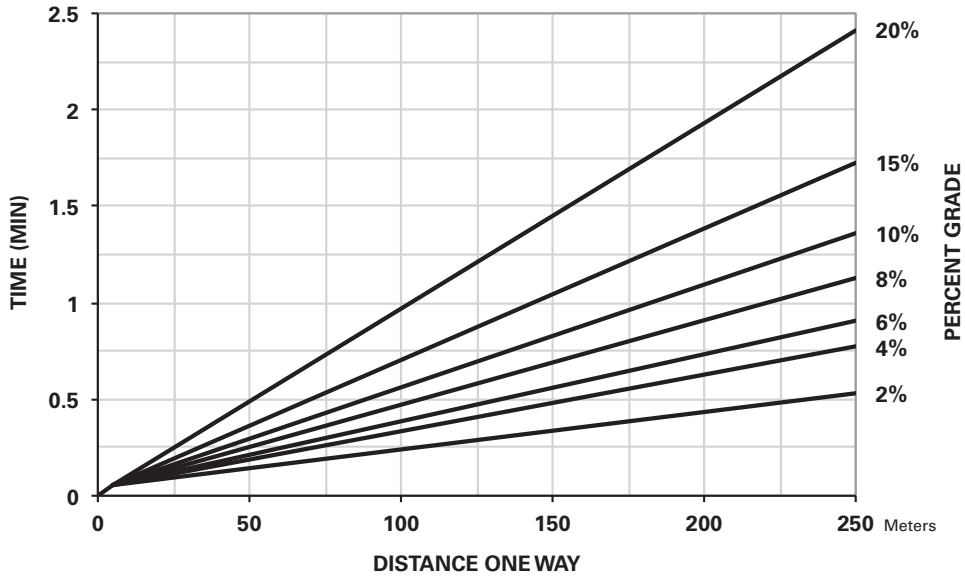

950K TRAVEL TIME — EMPTY

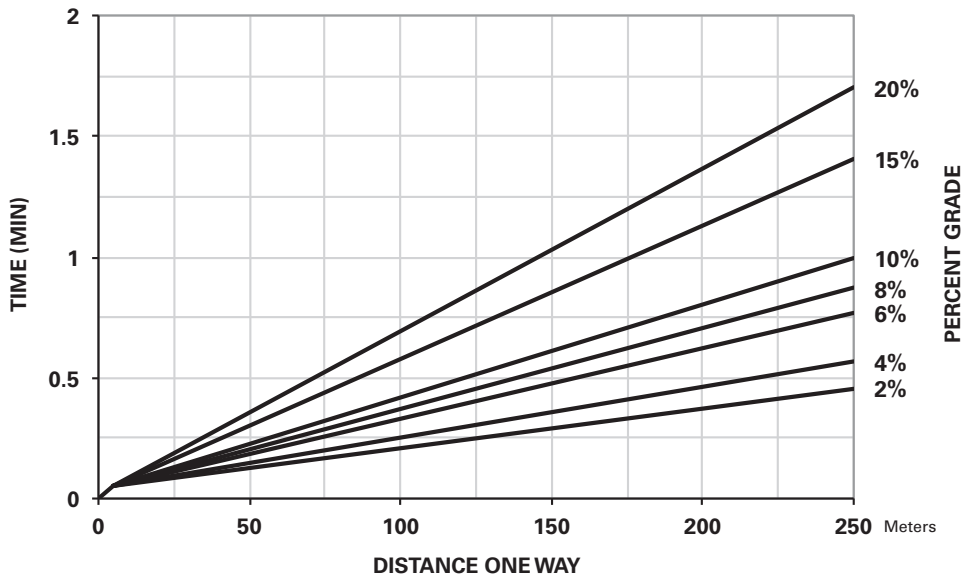

Contact your local Cat dealer for product availability.

Curves assume use of highest operating speed attainable.

In load-and-carry applications it is important to consult the tire manufacturer on load-speed ratings and pressure recommendations.

962K TRAVEL TIME — LOADED

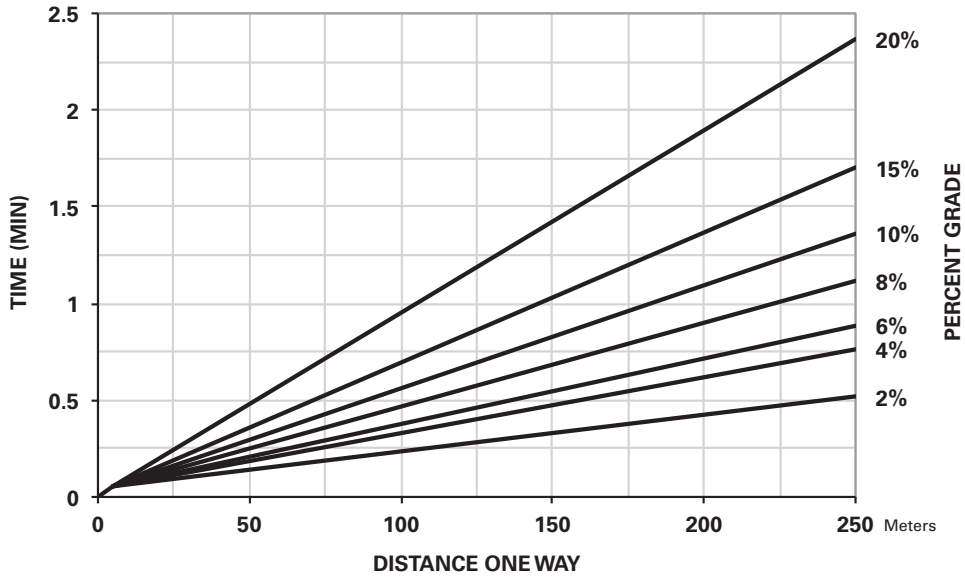

962K TRAVEL TIME — EMPTY

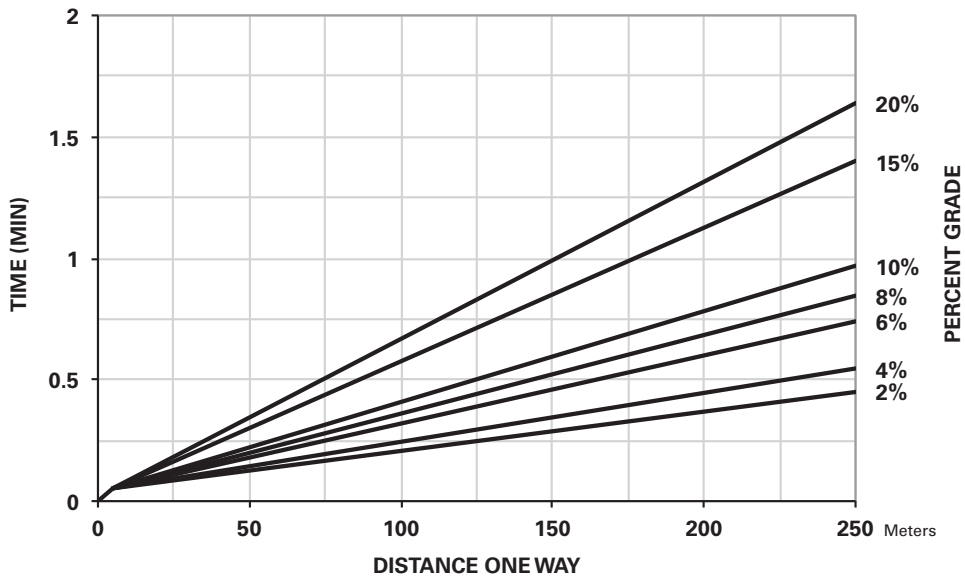

Contact your local Cat dealer for product availability.

Curves assume use of highest operating speed attainable.

In load-and-carry applications it is important to consult the tire manufacturer on load-speed ratings and pressure recommendations.

Wheel Loaders Integrated Toolcarriers

Travel Time — Loaded and Empty

- 966K
- 26.5-R25 Tires

966K TRAVEL TIME — LOADED

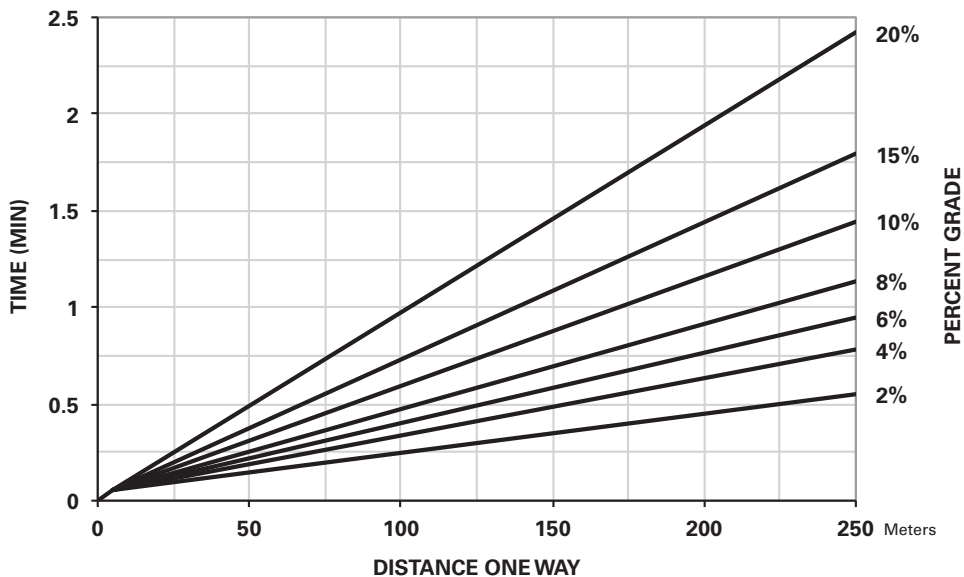

966K TRAVEL TIME — EMPTY

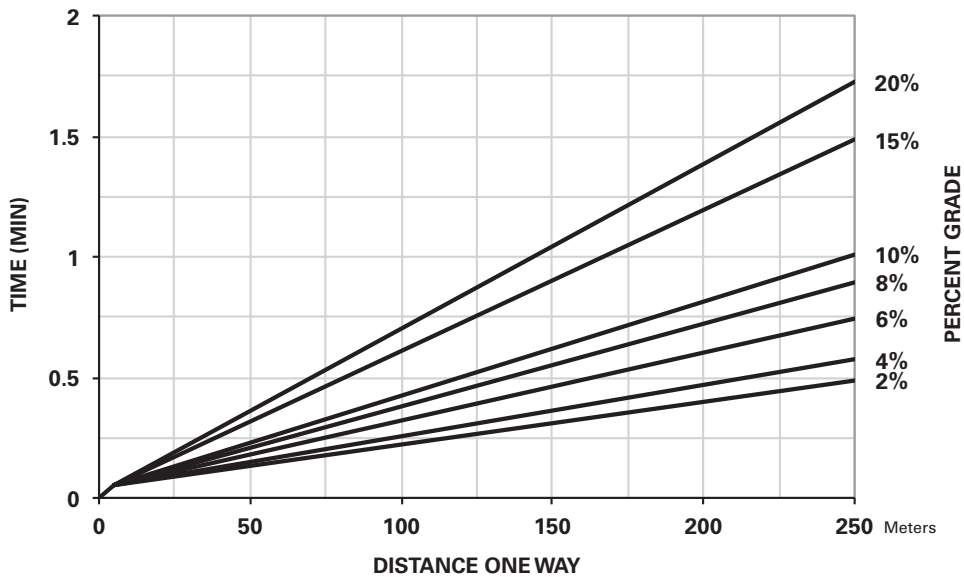

Contact your local Cat dealer for product availability.

Curves assume use of highest operating speed attainable.

In load-and-carry applications it is important to consult the tire manufacturer on load-speed ratings and pressure recommendations.

972K TRAVEL TIME — LOADED

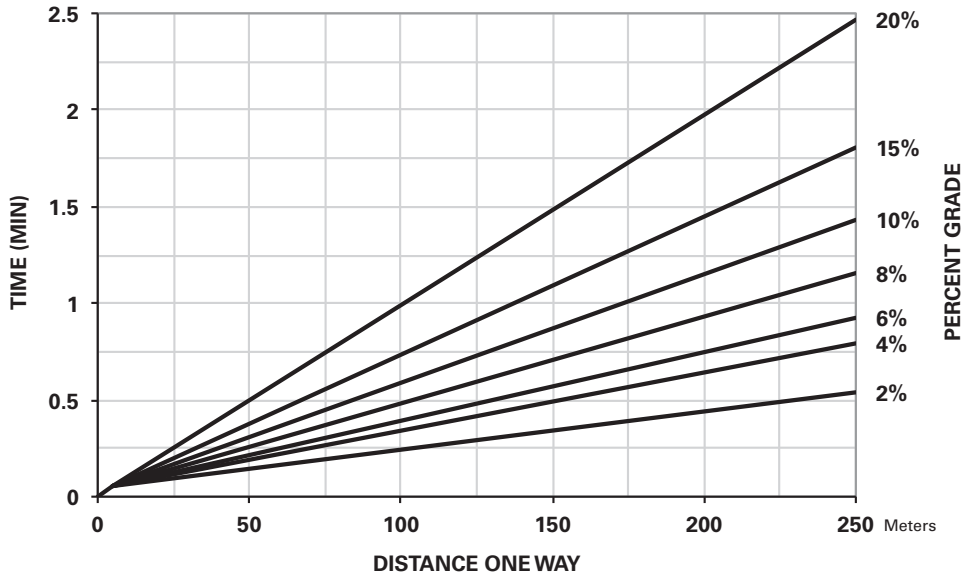

972K TRAVEL TIME — EMPTY

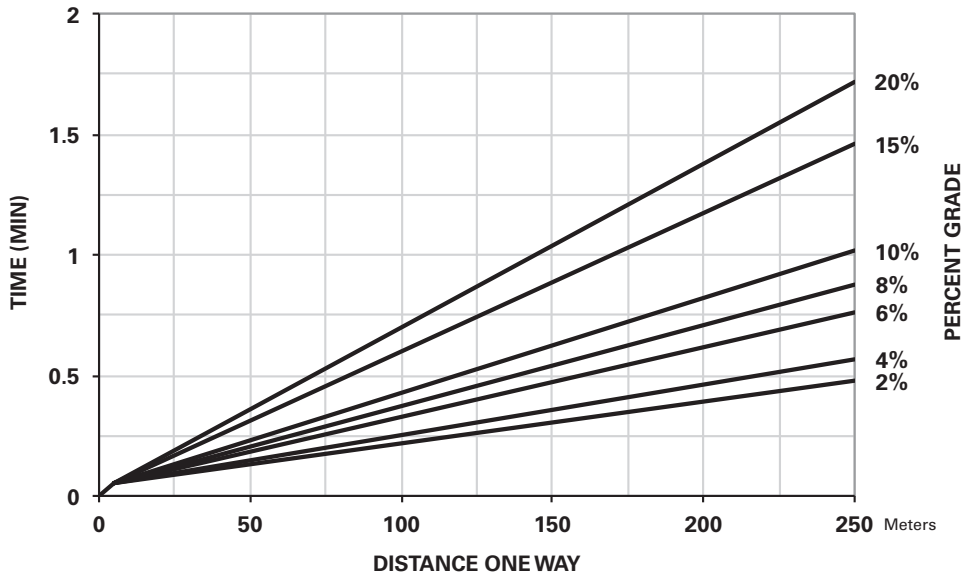

Contact your local Cat dealer for product availability.

Curves assume use of highest operating speed attainable.

In load-and-carry applications it is important to consult the tire manufacturer on load-speed ratings and pressure recommendations.

- 980K
- 29.5-R25 Tires

980K (NO LOCK-UP) TRAVEL TIME — LOADED

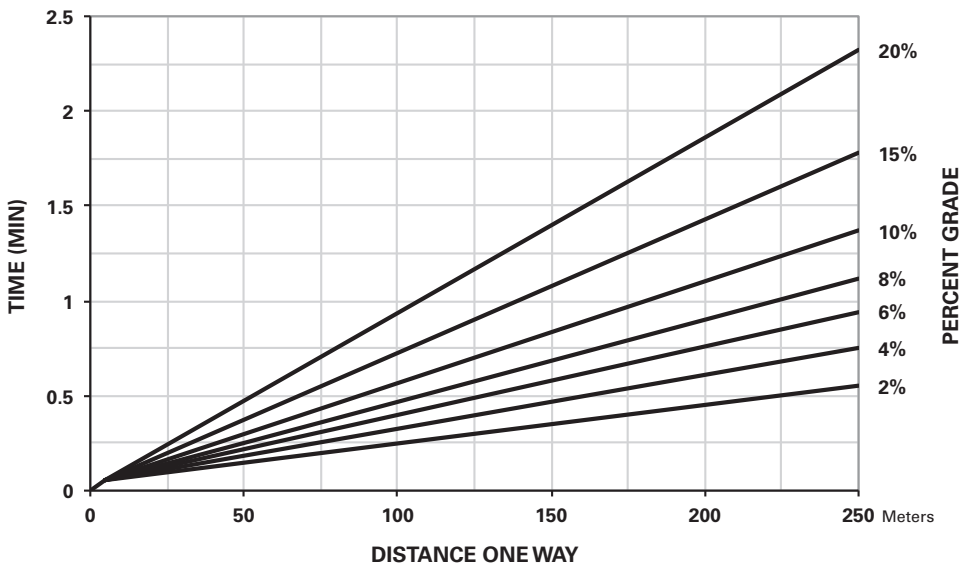

980K (NO LOCK-UP) TRAVEL TIME — EMPTY

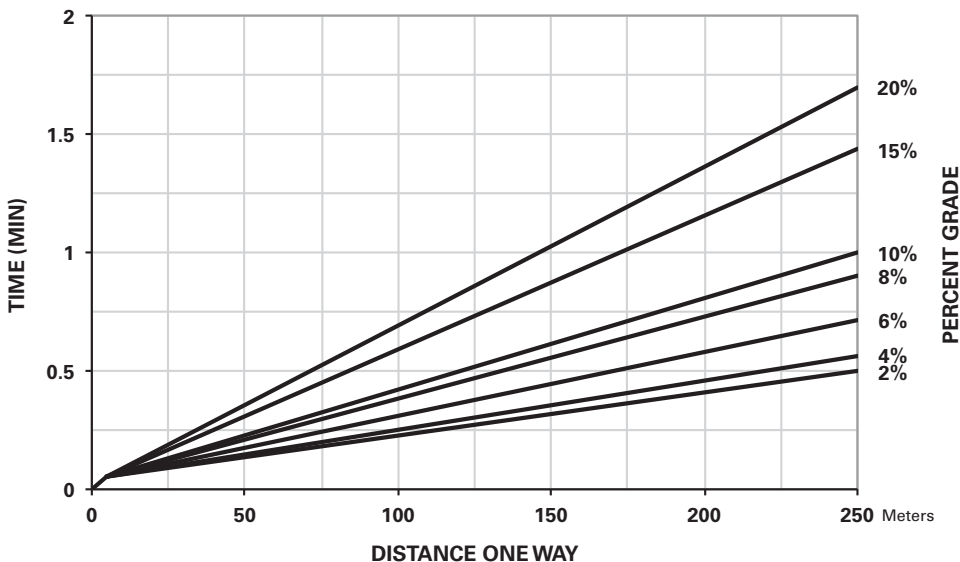

Contact your local Cat dealer for product availability.

Curves assume use of highest operating speed attainable.

In load-and-carry applications it is important to consult the tire manufacturer on load-speed ratings and pressure recommendations.

- 980K
- 29.5-R25 Tires

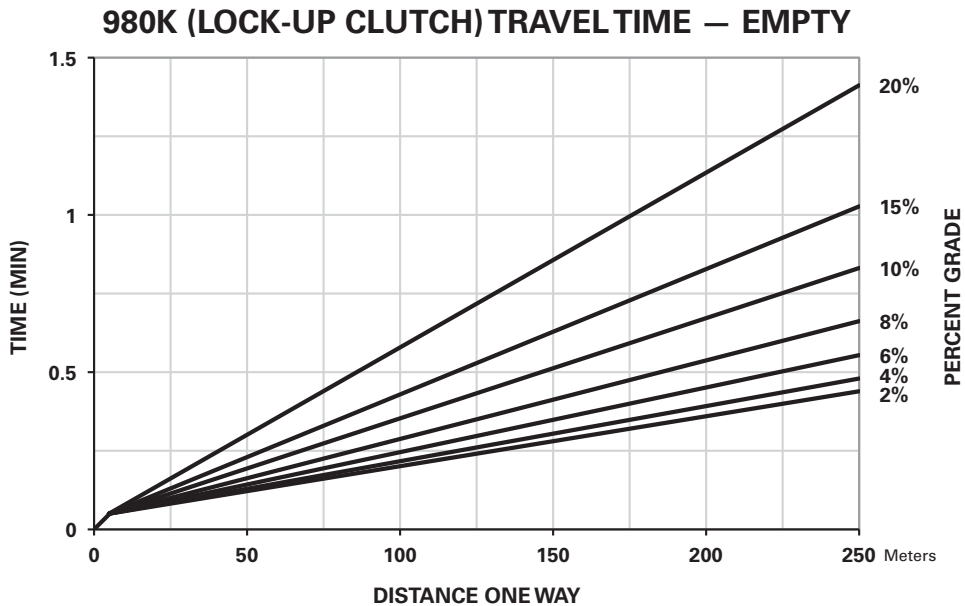
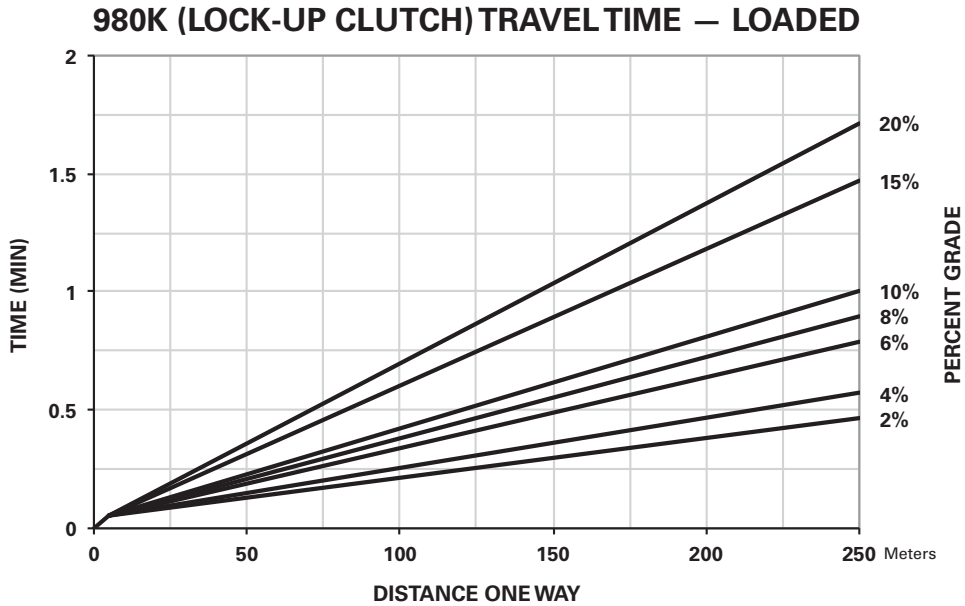

Contact your local Cat dealer for product availability.

Curves assume use of highest operating speed attainable.

In load-and-carry applications it is important to consult the tire manufacturer on load-speed ratings and pressure recommendations.

**Wheel Loaders
Integrated Toolcarriers**

Travel Time — Loaded and Empty

- 950H
- 23.5-R25 Tires

950H TRAVEL TIME — LOADED

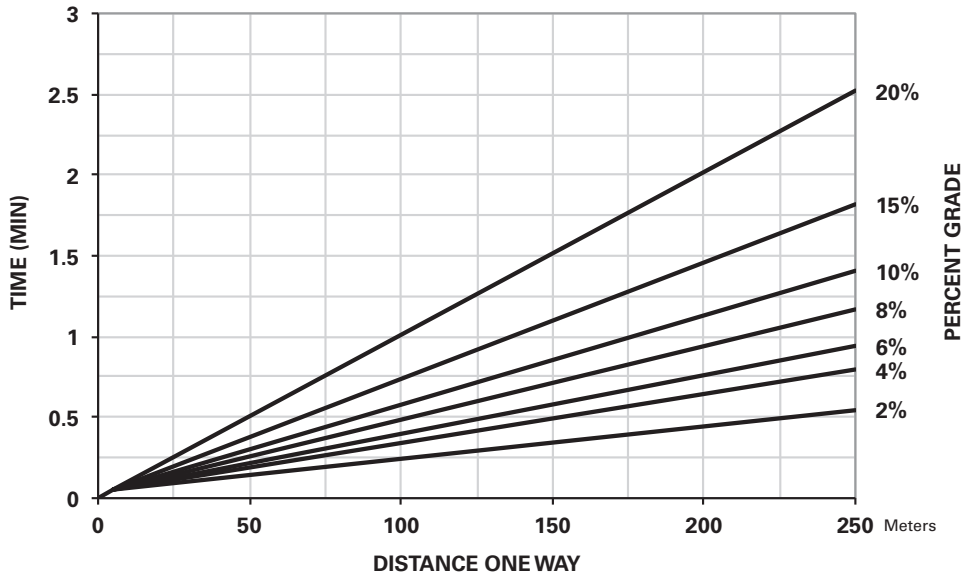

950H TRAVEL TIME — EMPTY

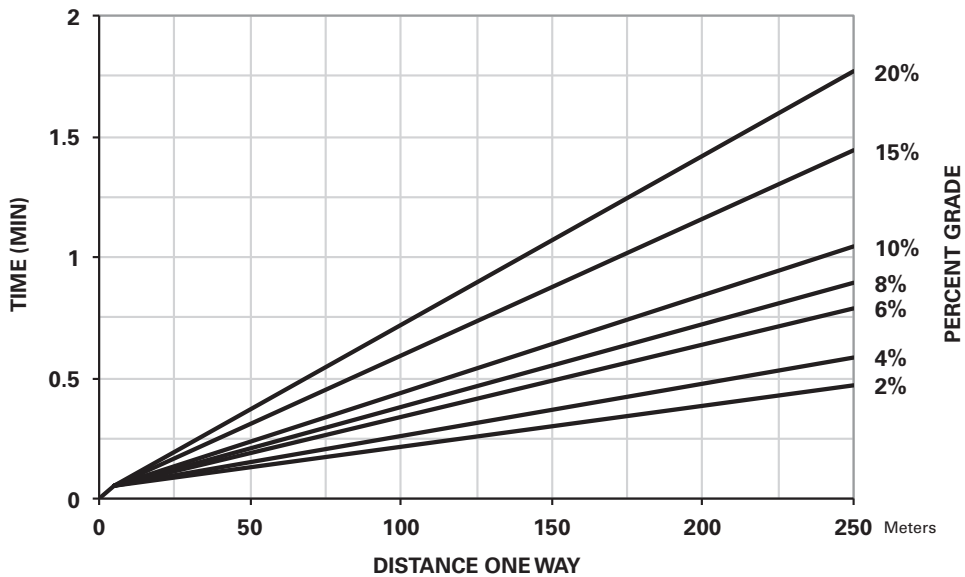

Not available in all regions. Contact your local Cat dealer for product availability.

Curves assume use of highest operating speed attainable.

In load-and-carry applications it is important to consult the tire manufacturer on load-speed ratings and pressure recommendations.

962H TRAVEL TIME — LOADED

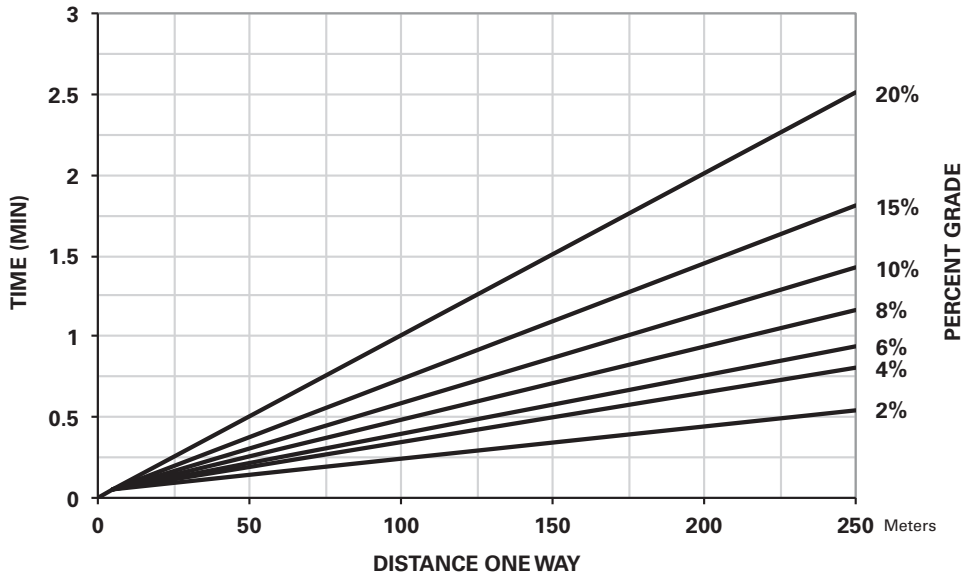

962H TRAVEL TIME — EMPTY

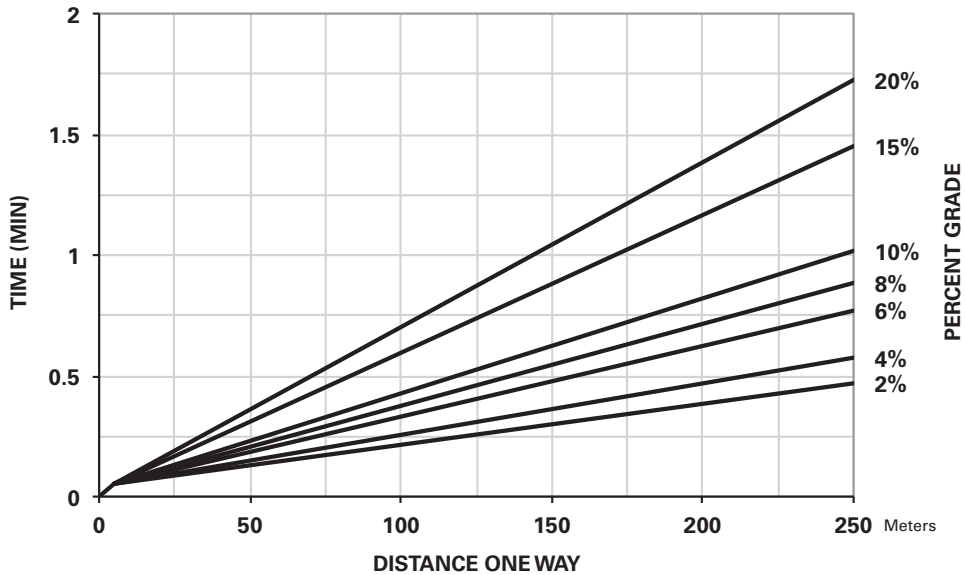

Not available in all regions. Contact your local Cat dealer for product availability.

Curves assume use of highest operating speed attainable.

In load-and-carry applications it is important to consult the tire manufacturer on load-speed ratings and pressure recommendations.

Wheel Loaders Integrated Toolcarriers

Travel Time — Loaded and Empty

- 966H
- 26.5-R25 Tires

966H TRAVEL TIME — LOADED

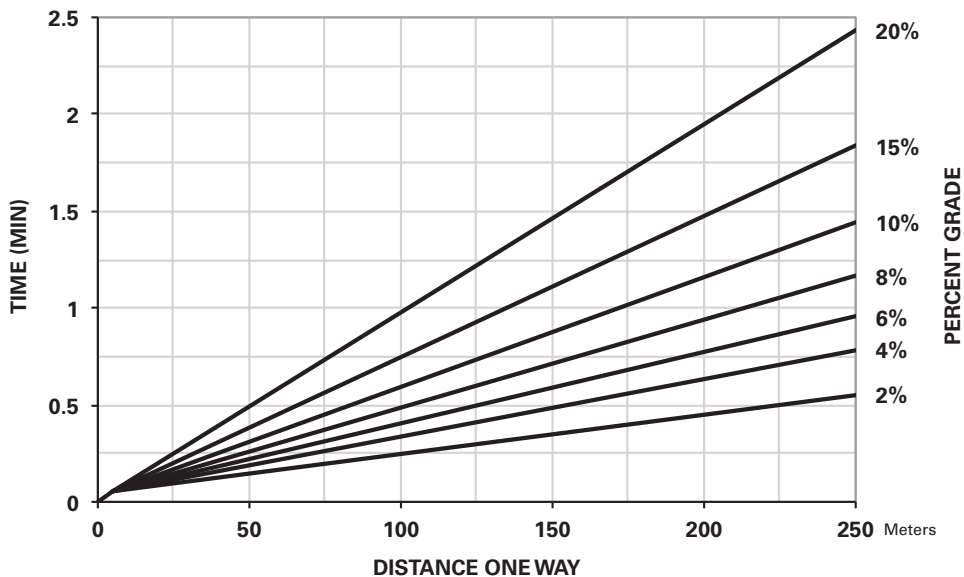

966H TRAVEL TIME — EMPTY

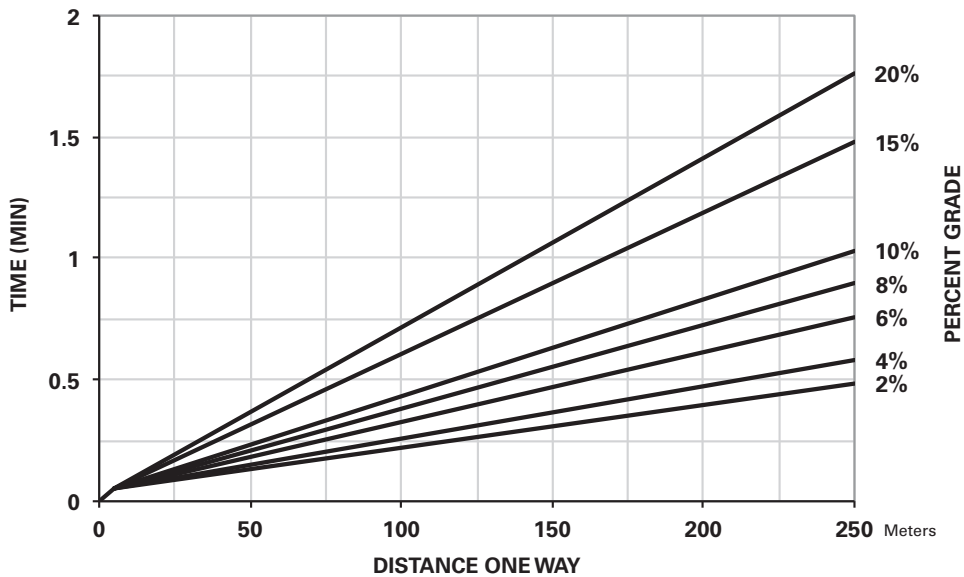

Not available in all regions. Contact your local Cat dealer for product availability.

Curves assume use of highest operating speed attainable.

In load-and-carry applications it is important to consult the tire manufacturer on load-speed ratings and pressure recommendations.

972H TRAVEL TIME — LOADED

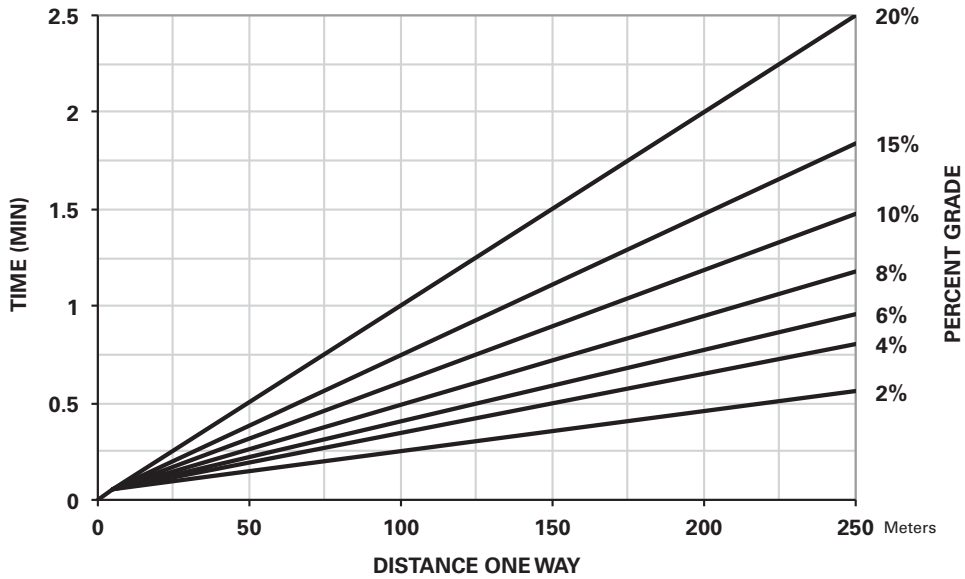

972H TRAVEL TIME — EMPTY

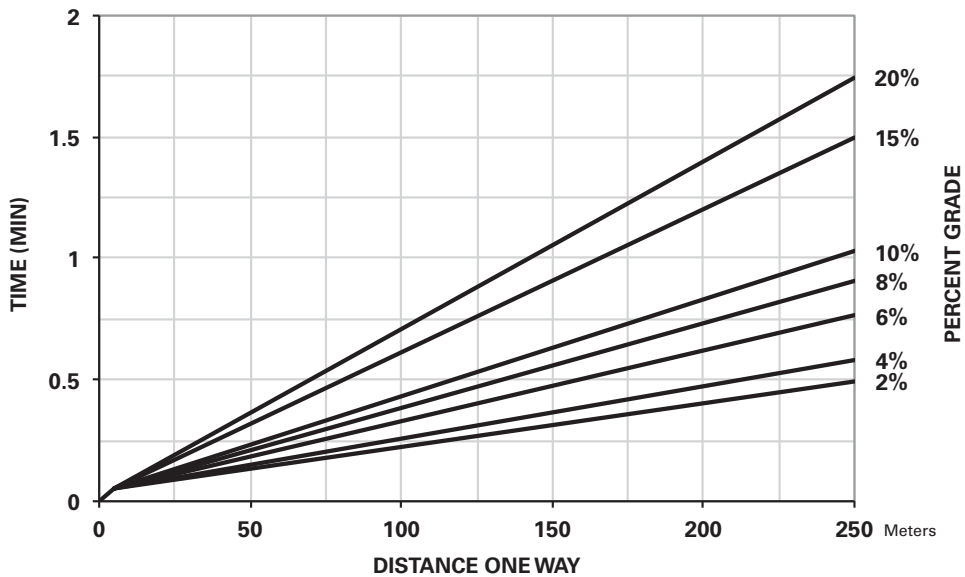

Not available in all regions. Contact your local Cat dealer for product availability.

Curves assume use of highest operating speed attainable.

In load-and-carry applications it is important to consult the tire manufacturer on load-speed ratings and pressure recommendations.

**Wheel Loaders
Integrated Toolcarriers**

Travel Time — Loaded and Empty

- 980H
- 29.5-R25 Tires

980H TRAVEL TIME — LOADED

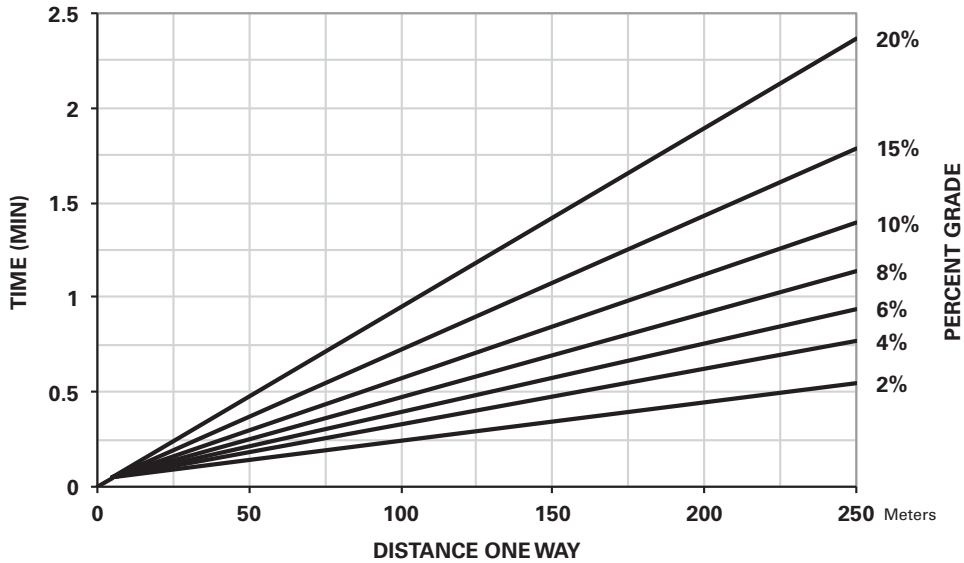

980H TRAVEL TIME — EMPTY

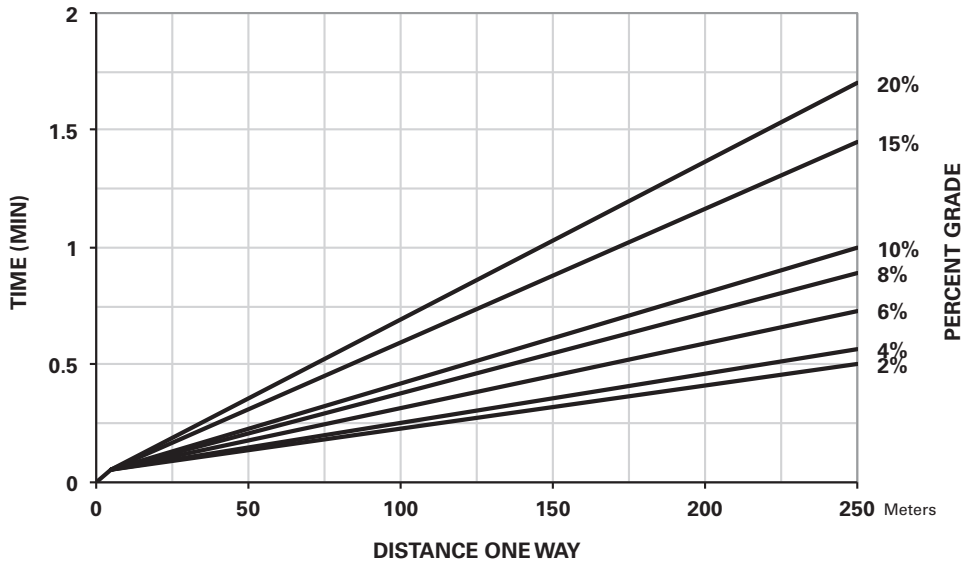

Not available in all regions. Contact your local Cat dealer for product availability.

Curves assume use of highest operating speed attainable.

In load-and-carry applications it is important to consult the tire manufacturer on load-speed ratings and pressure recommendations.

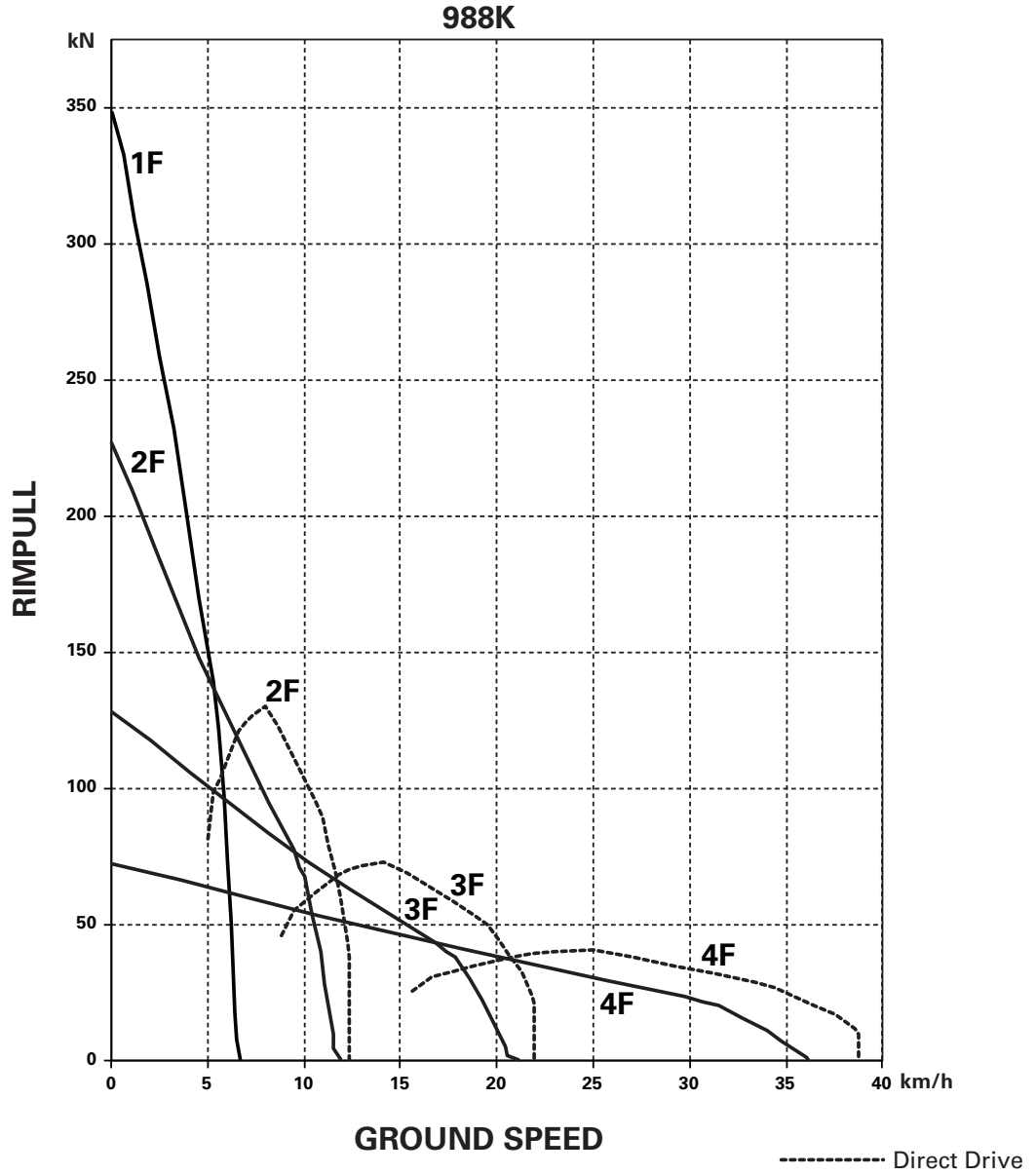

**Wheel Loaders
Integrated Toolcarriers**

- Travel Time — Loaded
- 988K — Lock-Up Clutch
 - 35/65-33 Tires

988K TRAVEL TIME — LOADED

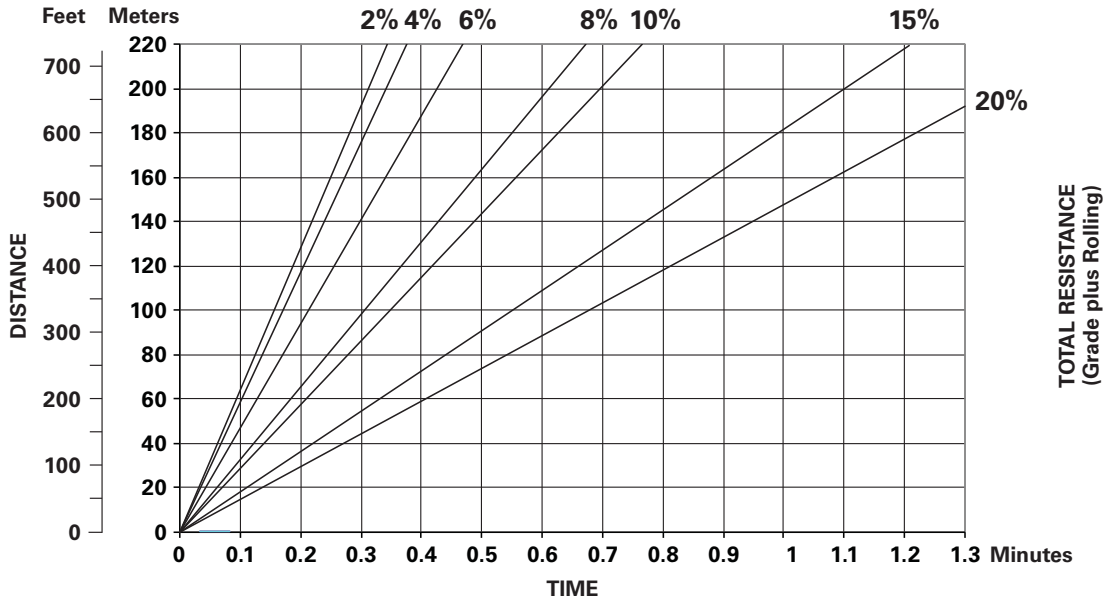

NOTE: Curves assume use of highest operating speed attainable: 4th gear for 2%-6% TR, 3rd gear for 8%-10% TR, 2nd gear for 15% and 20% TR.

In load-and-carry applications it is important to consult the tire manufacturer on Ton-MPH ratings and pressure recommendations.

- Travel Time — Empty
- 988K — Lock-Up Clutch
- 35/65-33 Tires

Wheel Loaders Integrated Toolcarriers

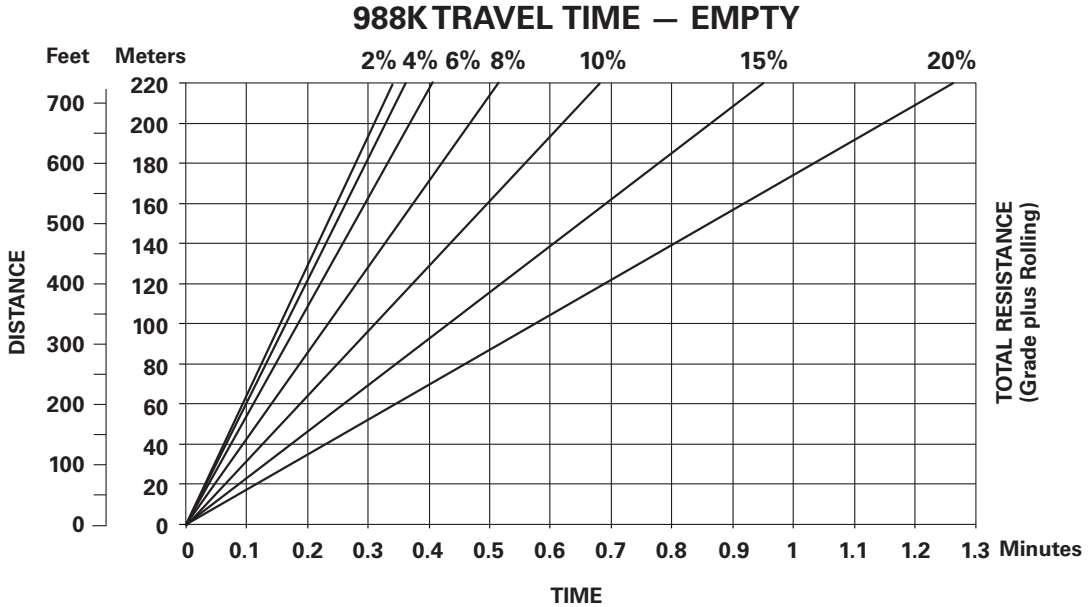

NOTE: Curves assume use of highest operating speed attainable: 4th gear for 2%-8% TR, 3rd gear for 10%-15% TR, 2nd gear for 20% TR.

In load-and-carry applications it is important to consult the tire manufacturer on Ton-MPH ratings and pressure recommendations.

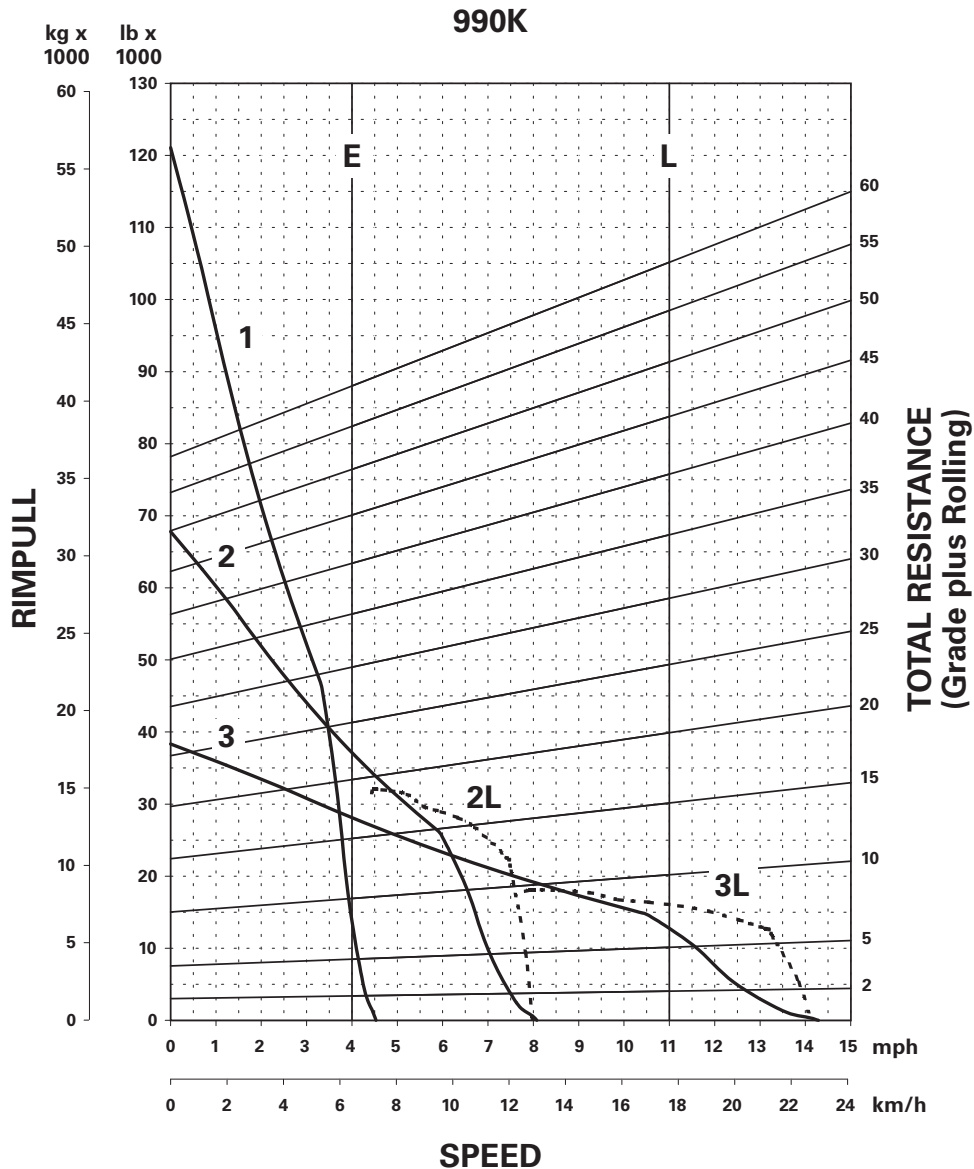

KEY

- 1 — 1st Gear
- 2 — 2nd Gear
- 3 — 3rd Gear

KEY

- E — Empty 80 974 kg (178,517 lb)
- L — Loaded 96 849 kg (213,515 lb)

Calculated Pull: Idle Hydraulics
Curves Assume NO SLIP Conditions

990K TRAVEL TIME — LOADED

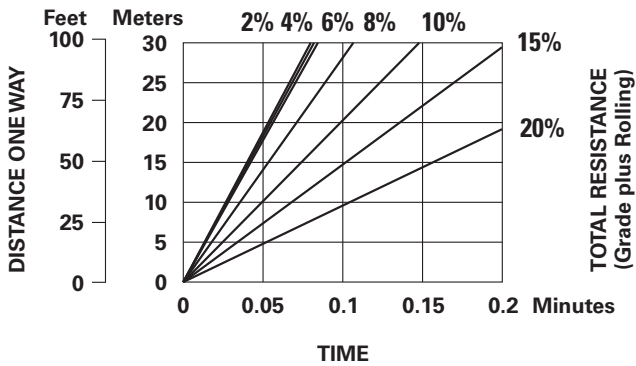
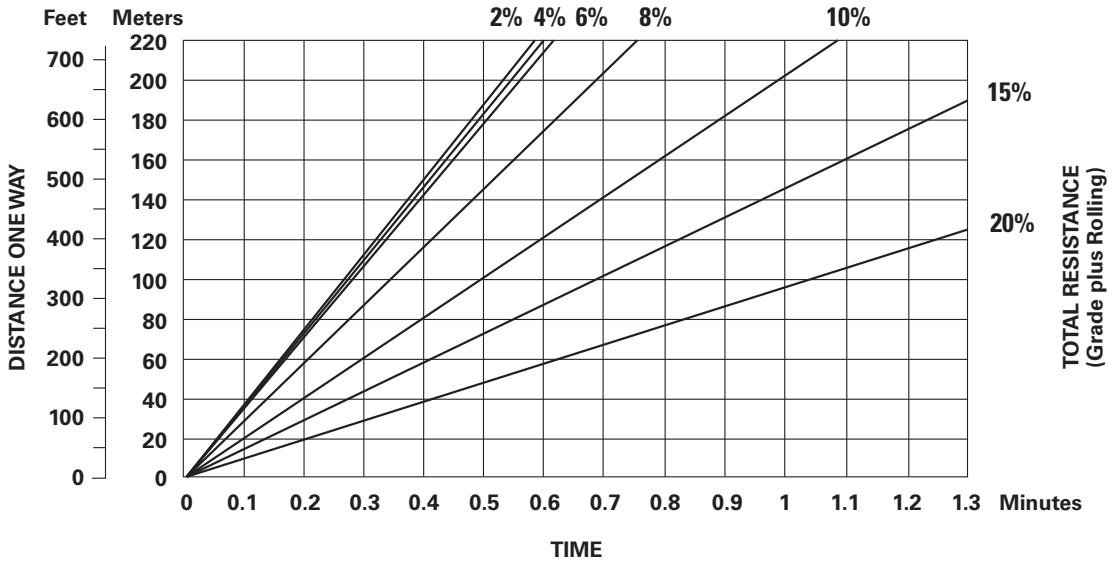

NOTE: Curves assume use of highest operating speed attainable: 3rd gear for 2%-8% TR, 2nd gear for 10%-20% TR.

In load-and-carry applications it is important to consult the tire manufacturer on Ton-MPH ratings and pressure recommendations.

- 990K
- 45/65R39 Tires

990K TRAVEL TIME — EMPTY

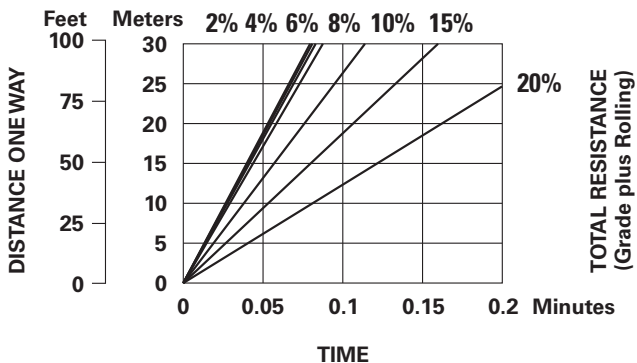
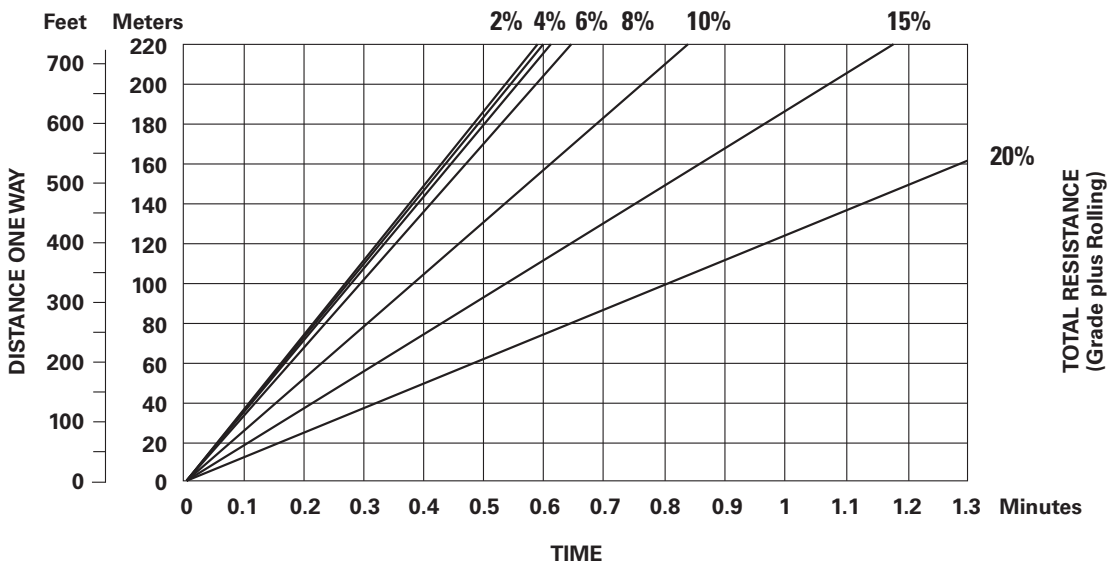

NOTE: Curves assume use of highest operating speed attainable: 3rd gear for 2%-10%TR, 2nd gear for 15% and 20%TR.

In load-and-carry applications it is important to consult the tire manufacturer on Ton-MPH ratings and pressure recommendations.

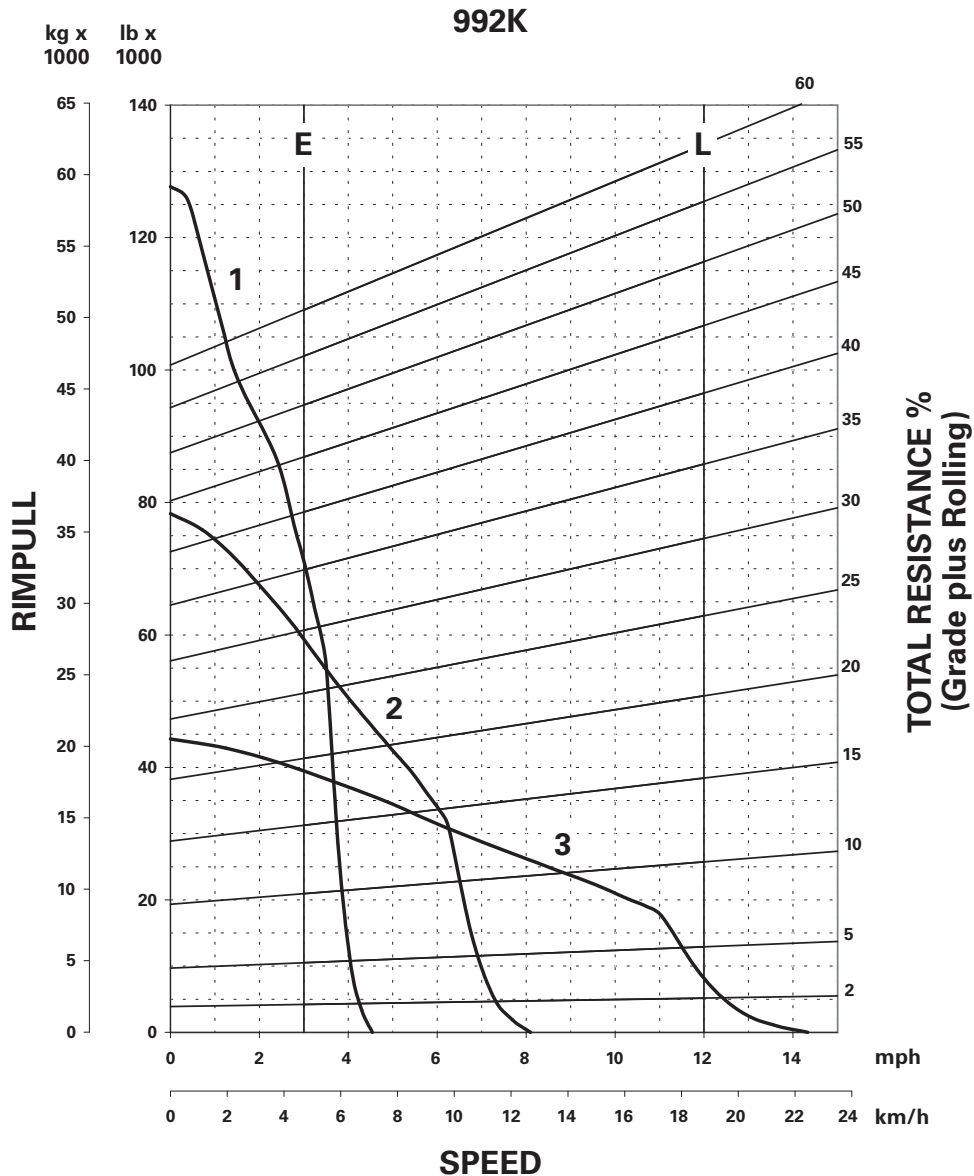

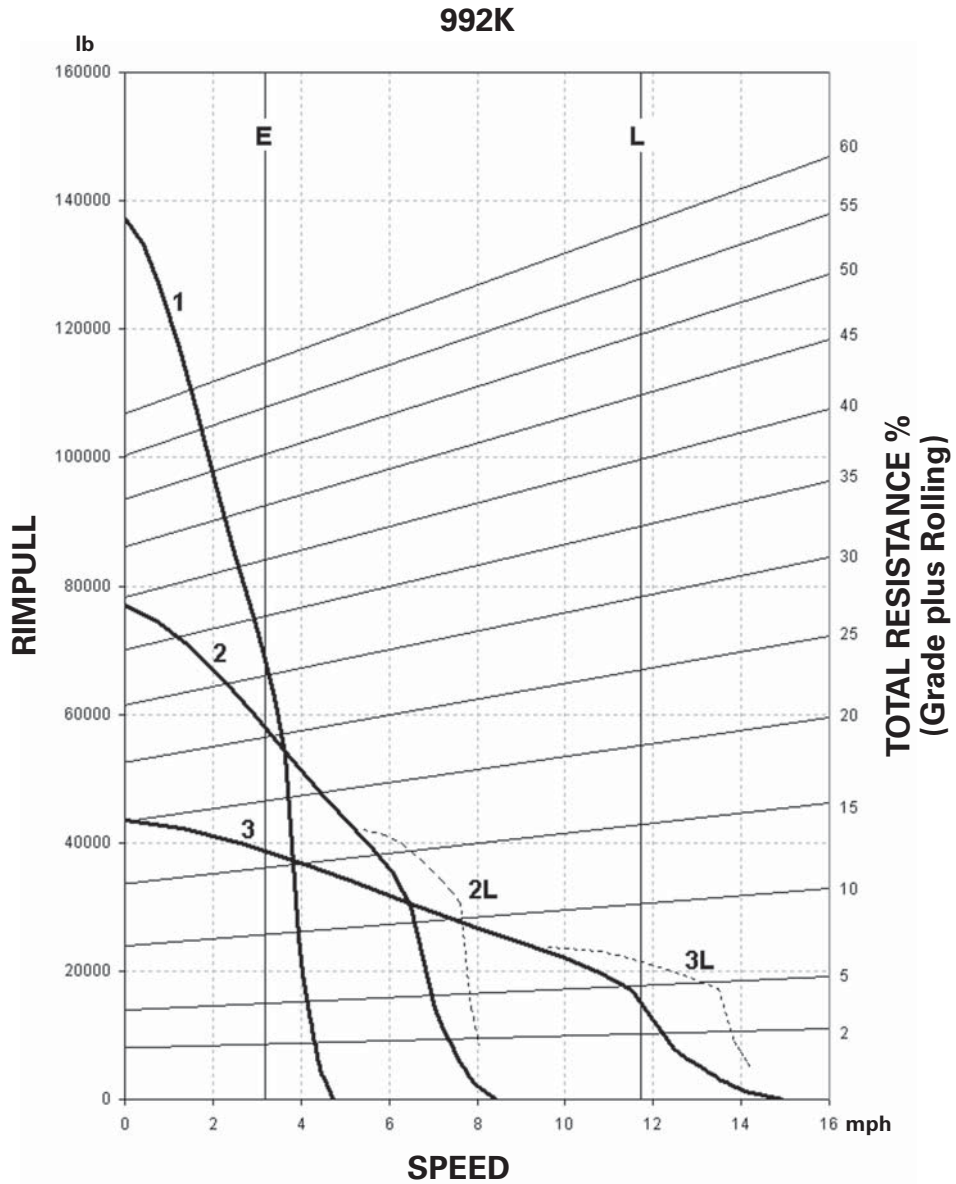

KEY

- 1 — 1st Gear
- 2 — 2nd Gear
- 3 — 3rd Gear

KEY

- E — Empty 92 797 kg (204,580 lb)
- L — Loaded 114 570 kg (252,580 lb)

Calculated Pull: Idle Hydraulics
Curves Assume NO SLIP Conditions

992K TRAVEL TIME — LOADED

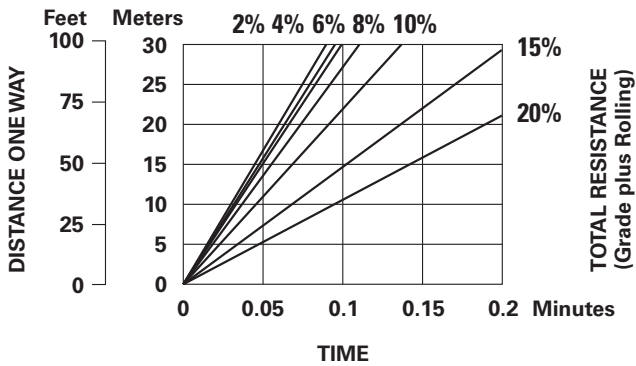
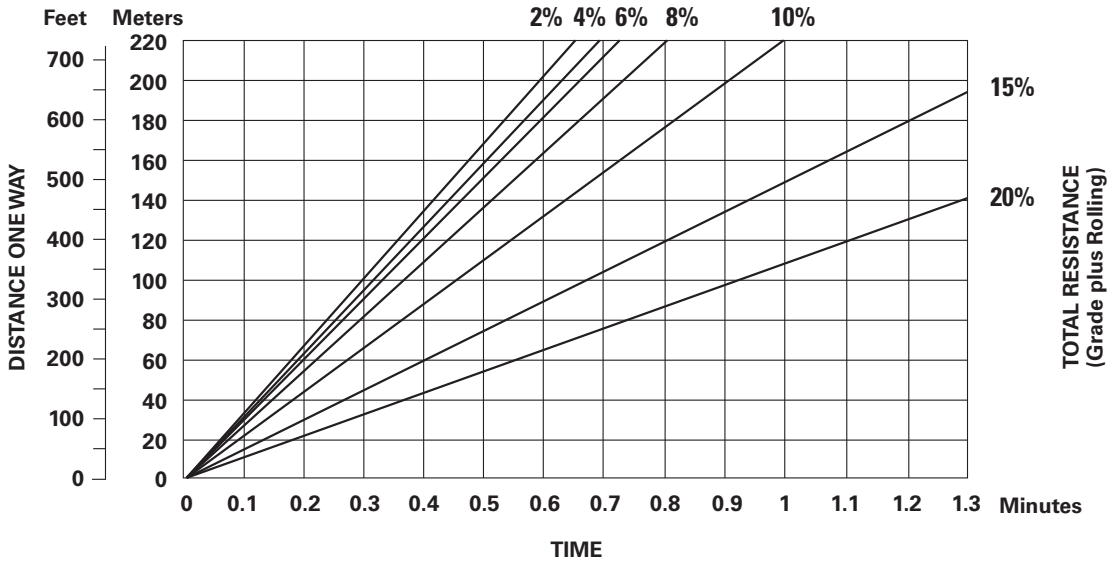

NOTE: Curves assume use of highest operating speed attainable: 3rd gear for 2%-10%TR, 2nd gear for 15% and 20% TR.

In load-and-carry applications it is important to consult the tire manufacturer on Ton-MPH ratings and pressure recommendations.

- 992K
- 45/65-45 Tires

992K TRAVEL TIME — EMPTY

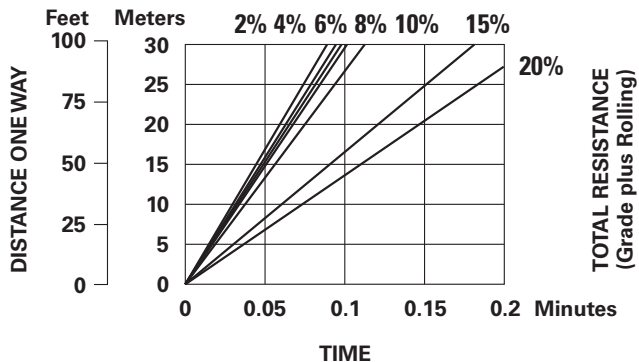
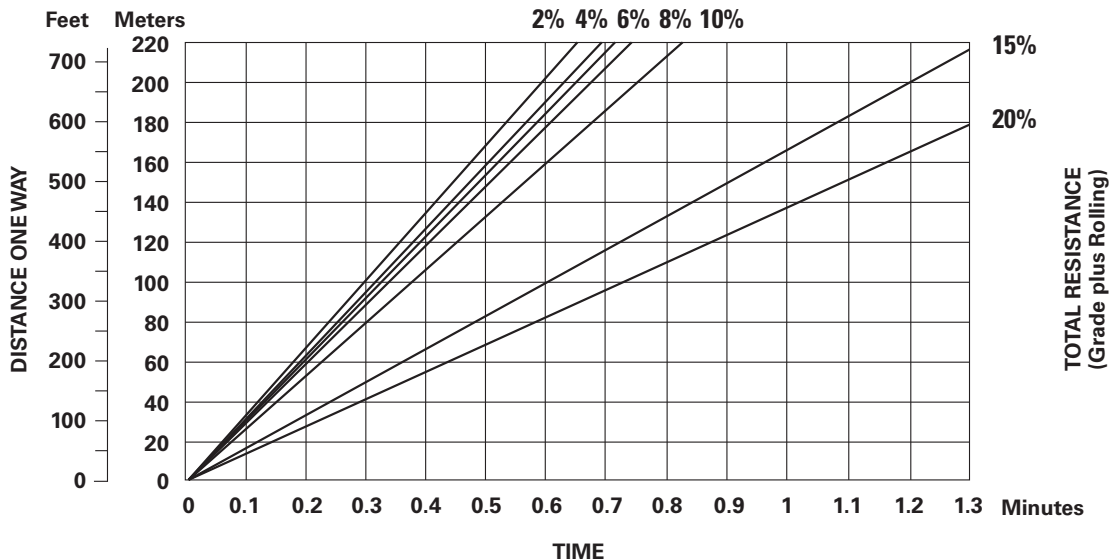

NOTE: Curves assume use of highest operating speed attainable: 3rd gear for 2%-10%TR, 2nd gear for 15% and 20% TR.

In load-and-carry applications it is important to consult the tire manufacturer on Ton-MPH ratings and pressure recommendations.

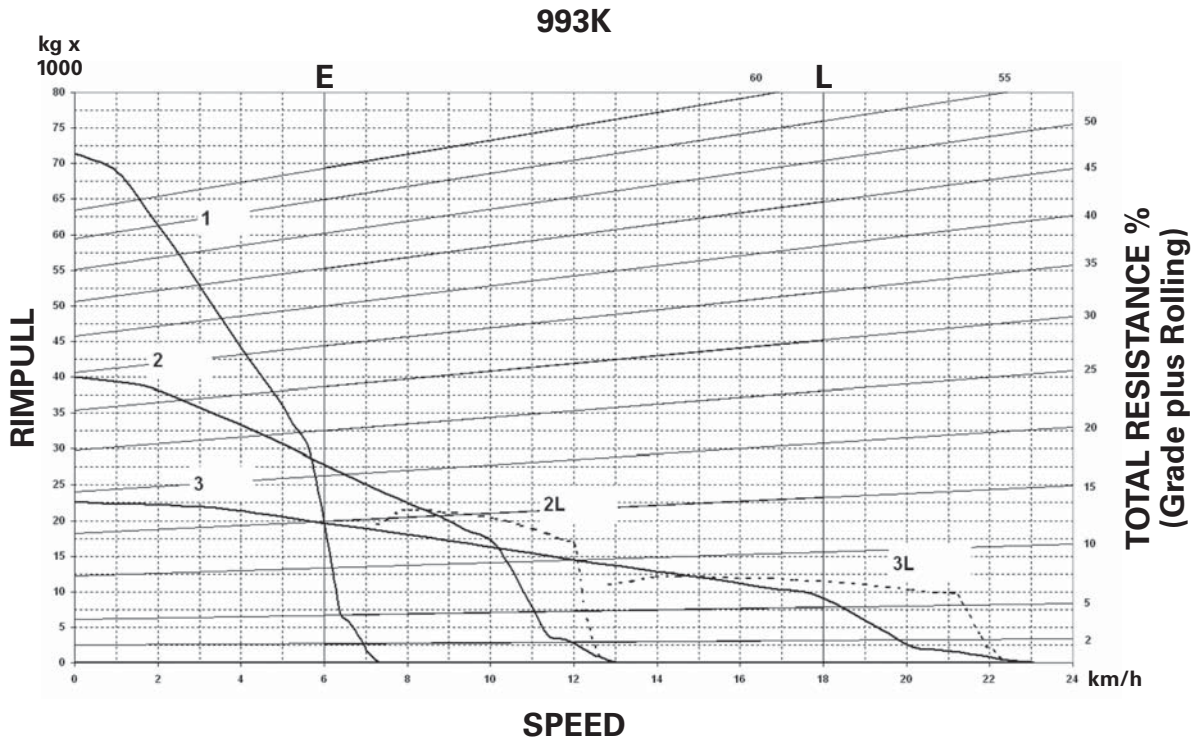

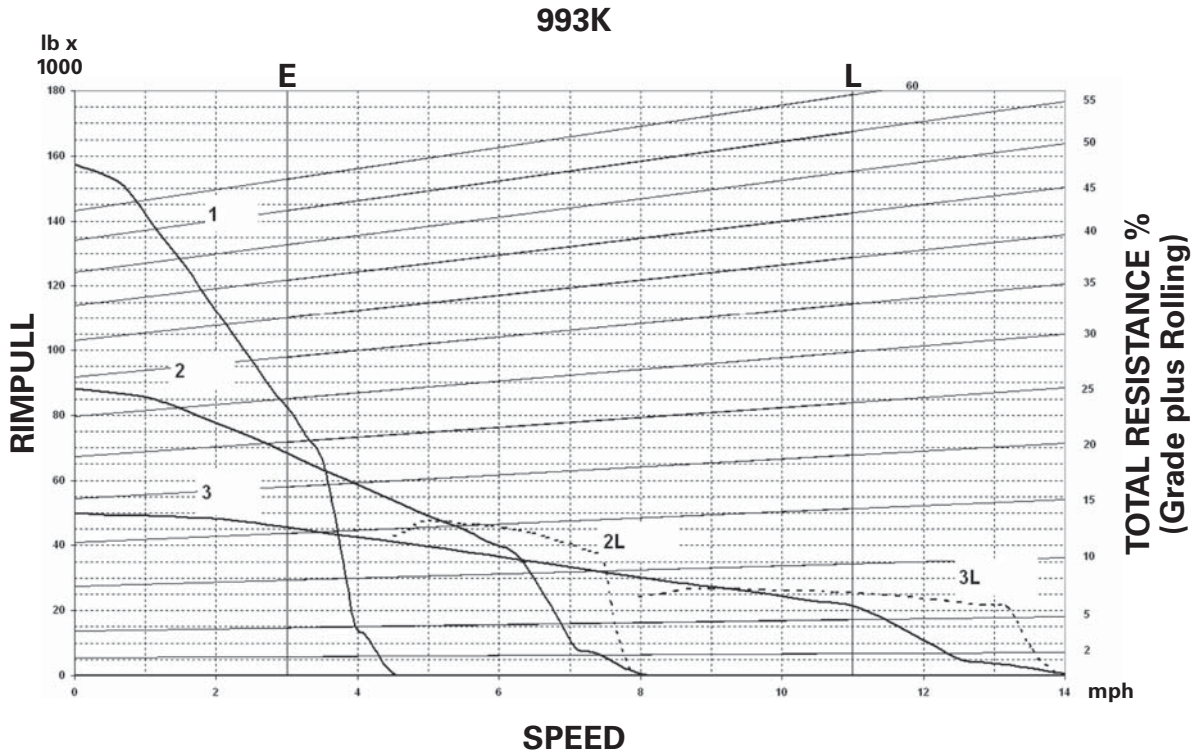

KEY

- 1 — 1st Gear
- 2 — 2nd Gear
- 3 — 3rd Gear

KEY

- E — Empty
- L — Loaded

Calculated Pull: Idle Hydraulics
Curves Assume NO SLIP
Conditions

- Travel Time — Empty
- 993K — Lock-Up Clutch
- Idle Hydraulics

**Wheel Loaders
Integrated Toolcarriers**

993K TRAVEL TIME — EMPTY

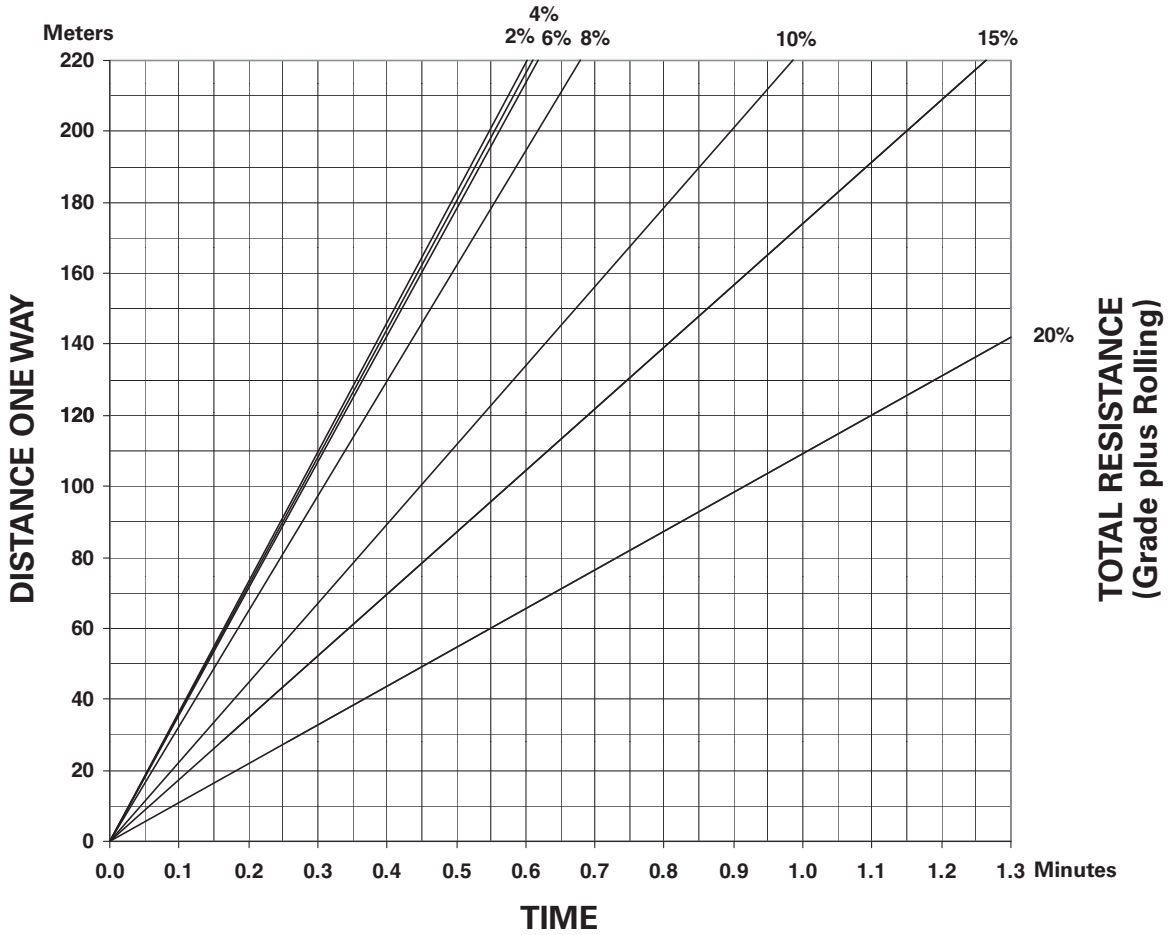

**Wheel Loaders
Integrated Toolcarriers**

- Travel Time — Loaded**
- 993K — Lock-Up Clutch
 - Idle Hydraulics

993K TRAVEL TIME — LOADED

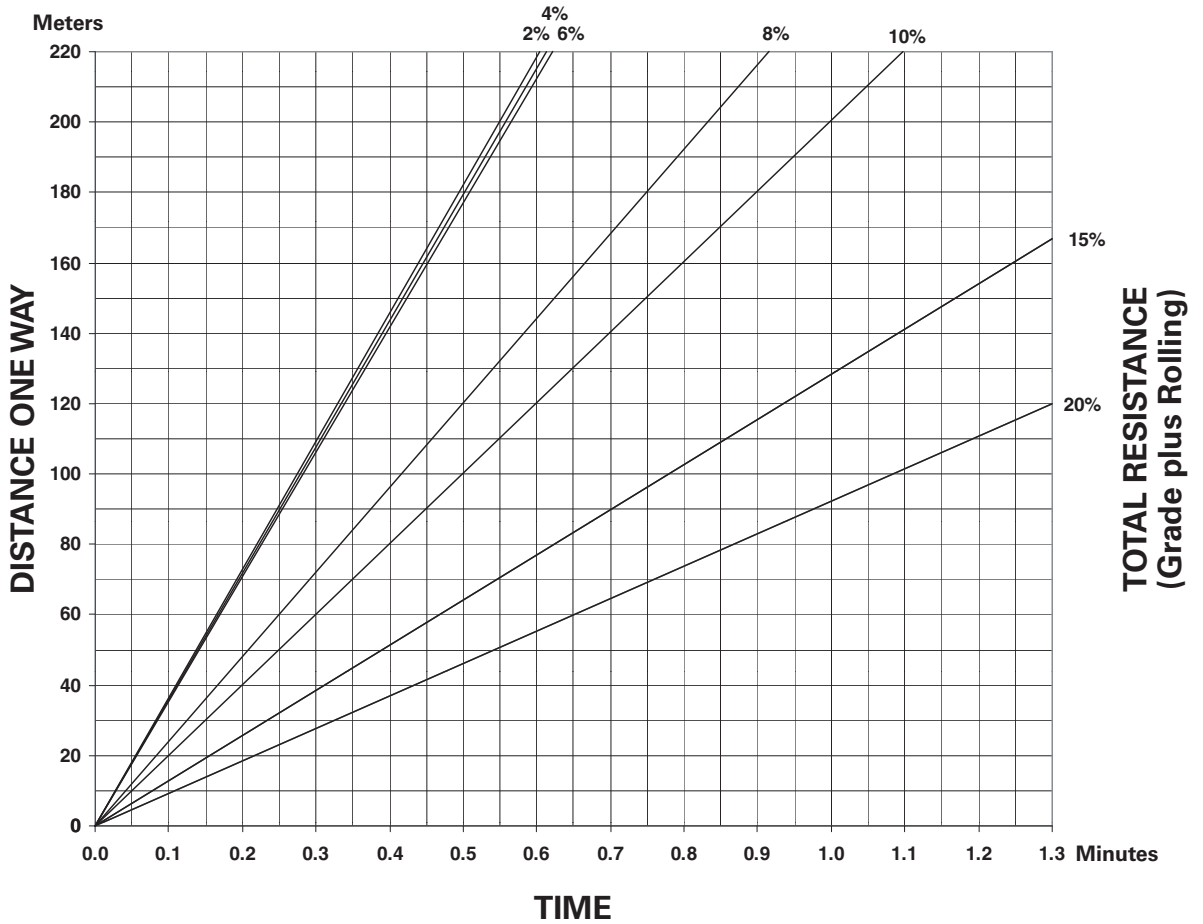

Travel Time — Empty

● 993K — Standard

● Idle Hydraulics

Wheel Loaders
Integrated Toolcarriers

993K TRAVEL TIME — EMPTY

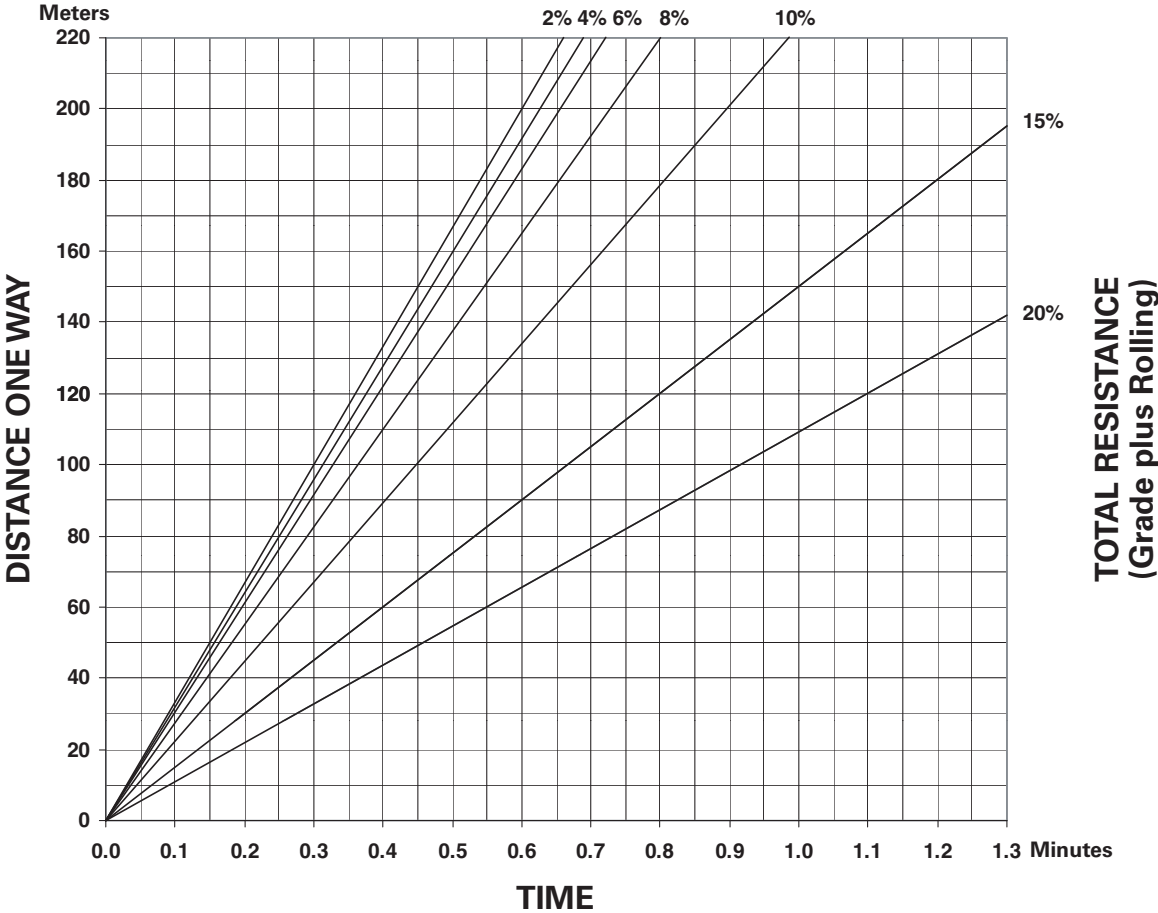

**Wheel Loaders
Integrated Toolcarriers**

Travel Time — Loaded

- 993K — Standard
- Idle Hydraulics

993K TRAVEL TIME — LOADED

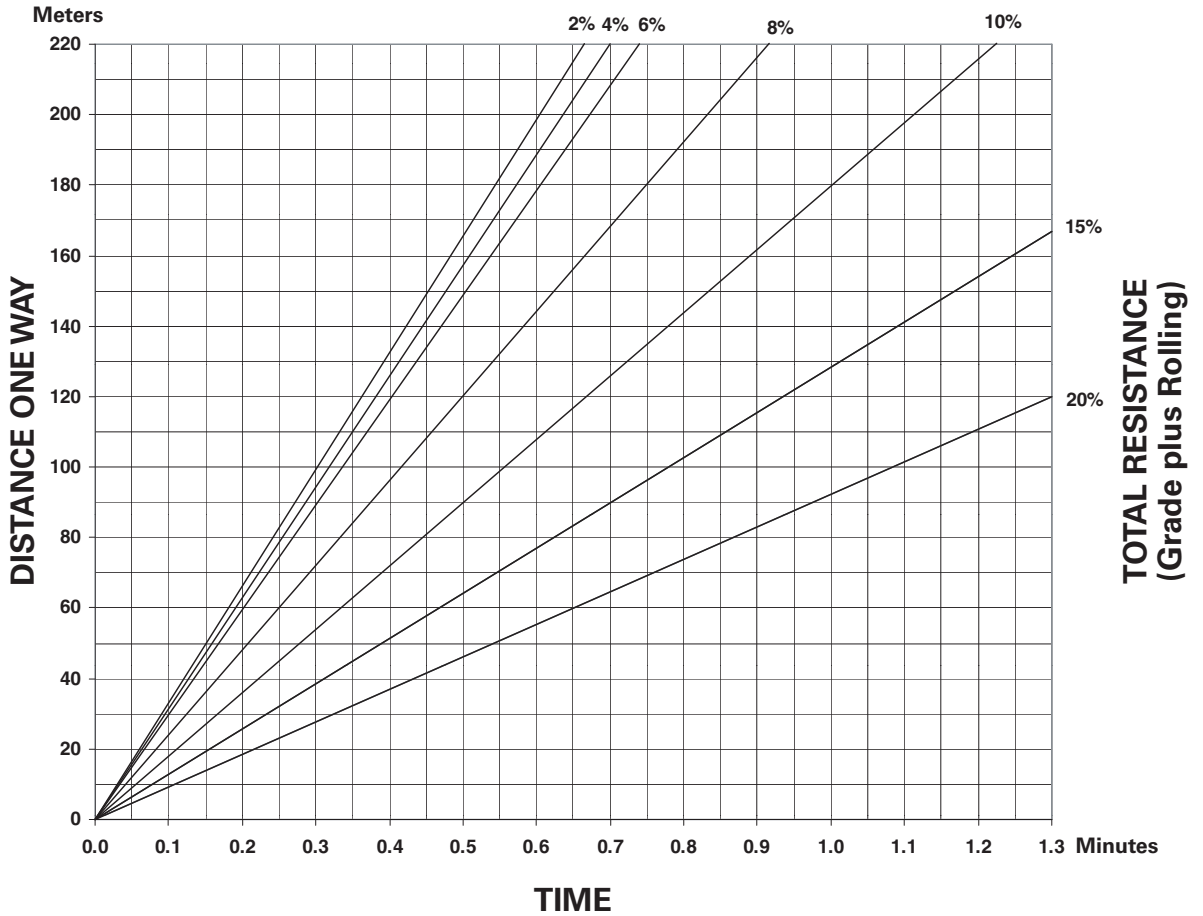

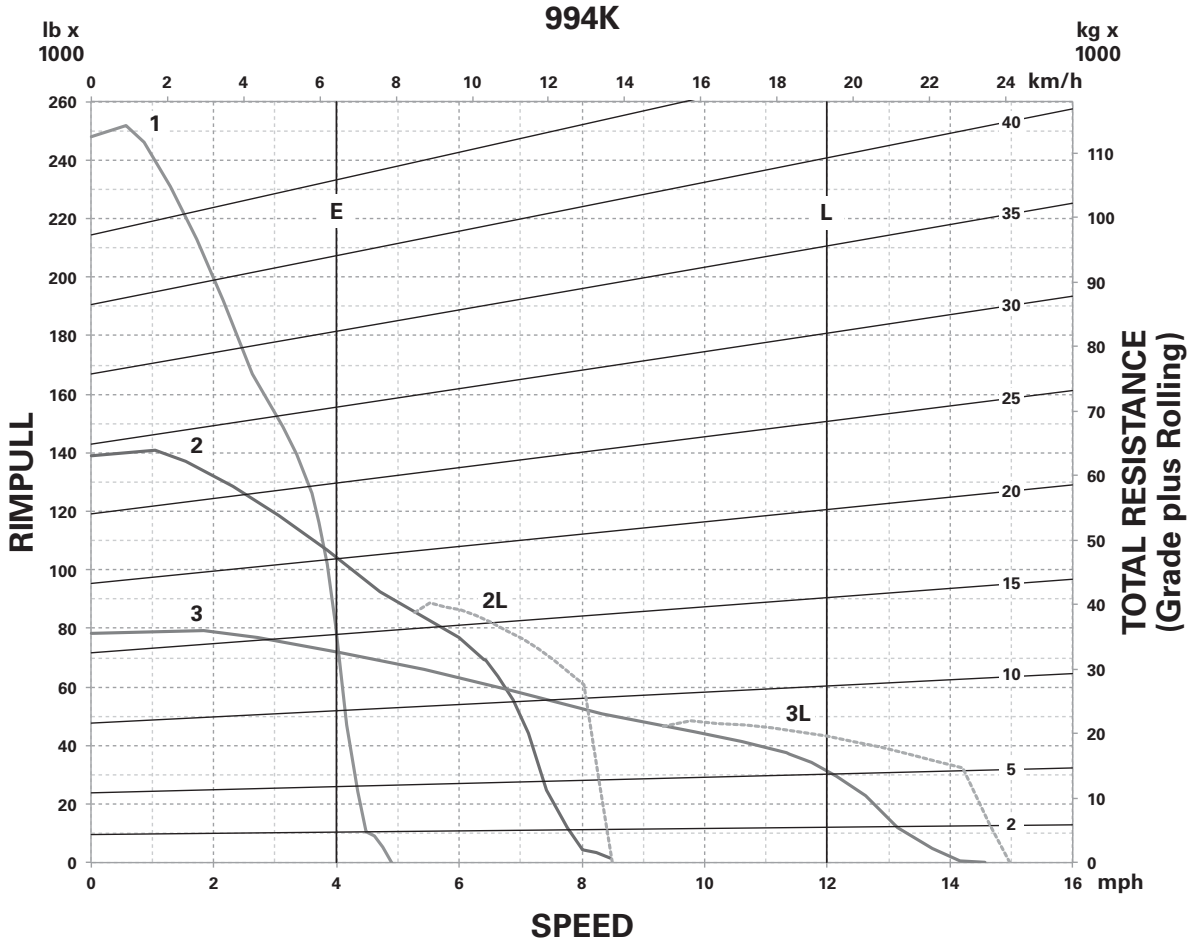

Wheel Loaders Integrated Toolcarriers

Travel Time — Loaded

- 994K Steady State
- 58/85-57 Tires

994K TRAVEL TIME — LOADED

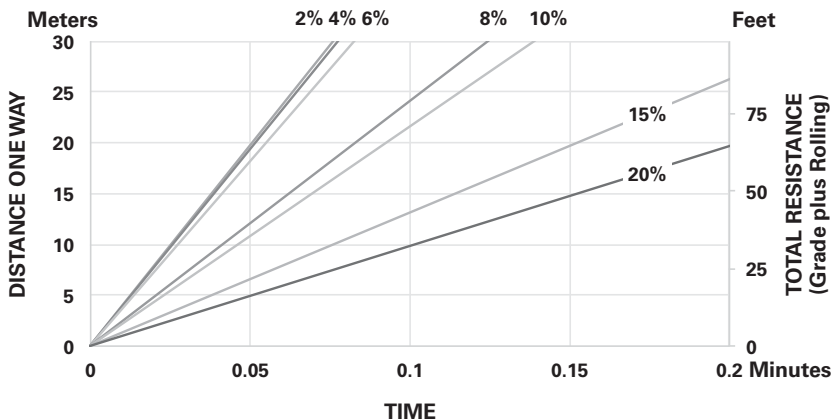
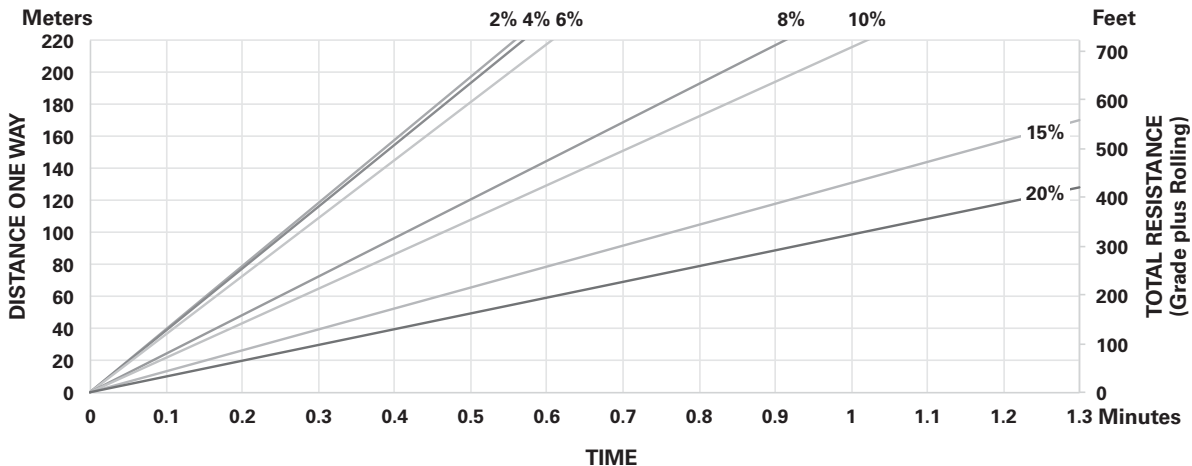

NOTE: Curves assume use of highest operating speed attainable: 3rd gear for 2%-8% TR, 2nd gear for 10% and 15% TR, 1st gear for 20% TR.

In load-and-carry applications it is important to consult the tire manufacturer on Ton-MPH ratings and pressure recommendations.

994K TRAVEL TIME — EMPTY

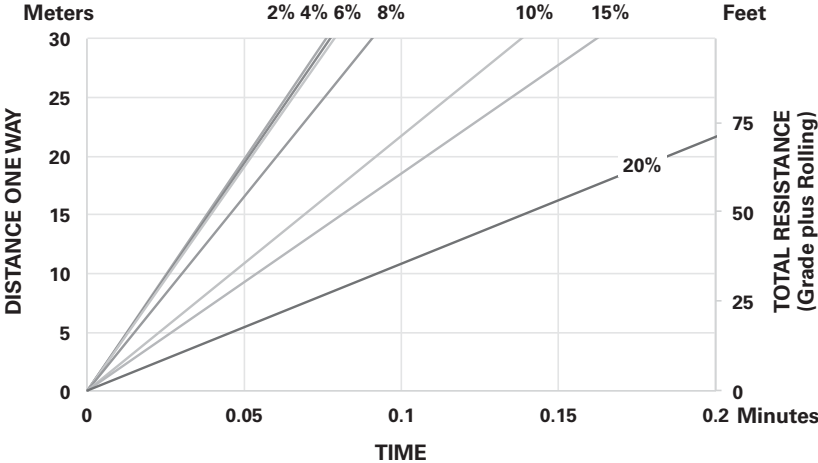
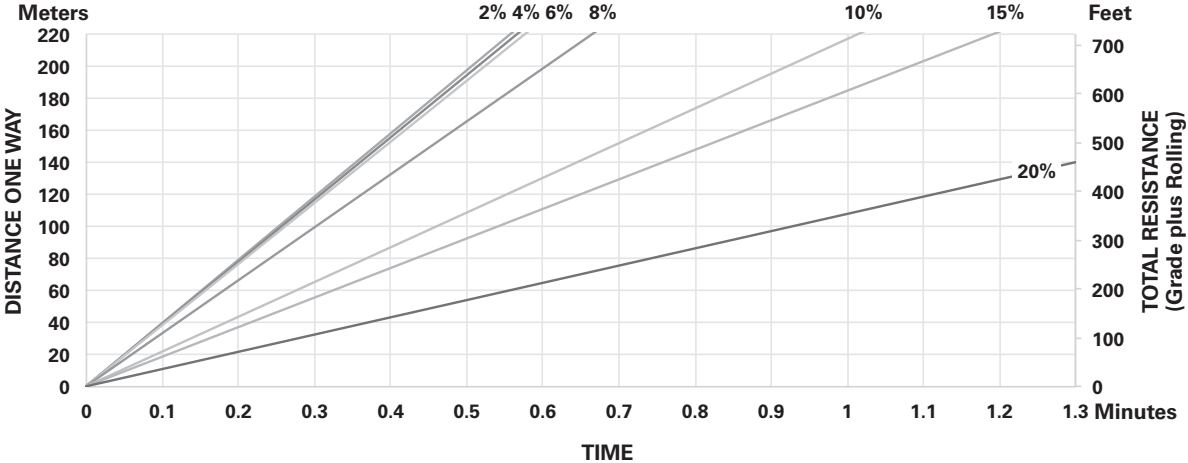

NOTE: Curves assume use of highest operating speed attainable: 3rd gear for 2%-10%TR, 2nd gear for 15% TR, 1st gear for 20% TR.

In load-and-carry applications it is important to consult the tire manufacturer on Ton-MPH ratings and pressure recommendations.

Wheel Loaders Integrated Toolcarriers

Production Estimating Table

● m³ or yd³/60 min. hour

Bucket Size (m ³ or yd ³)		1.0	1.5	2.0	2.5	3.0	3.5	4.0	4.5	5.0	5.5	6.0	6.5	7.0	7.5	8.0	8.5	9.0	9.5	10.0		
Cycle Time	Cycles Per Hr	Unshaded area indicates average production.																				
0.35	171																					
0.40	150	150	225	330	375	450	525															
0.45	133	135	200	268	332	400	466	530	600	665	730	800	865									
0.50	120	120	180	240	300	360	420	480	540	600	660	720	780	840	900	960	1003	1080	1140	1200		
0.55	109	109	164	218	272	328	382	436	490	545	600	655	705	765	820	870	925	980	1008	1090		
0.60	100	100	150	200	250	300	350	400	450	500	550	600	650	700	750	800	850	900	950	1000		
0.65	92	92	138	184	230	276	322	368	416	460	505	555	600	645	690	735	780	830	875	920		
0.70	86							342	386	430	474	515	560	600	645	690	730	775	815	860		
0.75	80												560	600	640	680	720	760	800			

Bucket Size (m ³ or yd ³)		11.0	12.0	13.0	14.0	15.0	16.0	17.0	18.0	19.0	20.0	21.0	22.0	23.0	24.0	25.0	26.0
Cycle Time	Cycles Per Hr	Unshaded area indicates average production.															
0.35	171																
0.40	150																
0.45	133																
0.50	120	1320	1440														
0.55	109	1200	1310	1420	1520	1635	1740	1850	1960	2070	2180	2285	2395	2505	2615	2725	2830
0.60	100	1100	1200	1300	1400	1500	1600	1700	1800	1900	2000	2100	2200	2300	2400	2500	2600
0.65	92	1010	1105	1195	1285	1380	1470	1560	1655	1745	1840	1930	2020	2115	2205	2300	2390
0.70	86	945	1030	1120	1200	1290	1375	1460	1545	1630	1720	1805	1890	1975	2060	2150	2235
0.75	80	880	960	1040	1120	1200	1280	1360	1440	1520	1600	1680	1760	1840	1920	2000	2080
0.80	75			975	1050	1125	1200	1275	1350	1425	1500	1575	1650	1725	1800	1875	1950

Job Efficiency Worktime/Hr

60 Min Hr

55

50

45

40

—

Efficiency Factor

100%

91%

83%

75%

69%

—

Bucket Load Factor

Bucket Size × 1.00

0.95

0.90

0.85

0.80

0.75

Production Estimating Table
 ● 60 min hour ● Shot Rock
 ● Metric Tons

Wheel Loaders
 Integrated Toolcarriers

Metric Tons ● 1600 kg Lm³ (1.6 t) density

Bucket Size m ³		1.0	1.5	2.0	2.5	3.0	3.5	4.0	4.5	5.0	5.5	6.0	6.5	7.0	7.5	8.0	8.5	9.0	9.5
Cycle Time	Cycles Per Hr	Unshaded area indicates average production.																	
0.40	150	240	360	480	600	720													
0.45	133	213	319	426	532	638	745	851	958	1064	1170								
0.50	120	192	288	384	480	576	672	768	864	960	1056	1152	1248	1344	1440	1536	1632	1730	1825
0.55	109	174	262	349	436	523	610	698	785	872	959	1046	1134	1221	1308	1395	1482	1570	1655
0.60	100	160	240	320	400	480	560	640	720	800	880	960	1040	1120	1200	1280	1360	1440	1520
0.65	92	147	221	294	368	442	515	589	662	736	810	883	957	1030	1104	1178	1251	1325	1400
0.70	86						482	550	619	688	757	826	894	963	1032	1101	1170	1238	1310
0.75	80											768	832	896	960	1024	1088	1150	1215
Bucket Payload Metric (Tons)		1.6	2.4	3.2	4.0	4.8	5.6	6.4	7.2	8.0	8.8	9.6	10.4	11.2	12.0	12.8	13.6	14.4	15.2

Bucket Size m ³		10.0	11.0	12.0	13.0	14.0	15.0	16.0	17.0	18.0	19.0	20.0
Cycle Time	Cycles Per Hr	Unshaded area indicates average production.										
0.40	150											
0.45	133											
0.50	120											
0.55	109	1744	1918	2092	2267	2441	2616	2790	2964	3139	3313	3488
0.60	100	1600	1760	1920	2080	2240	2400	2560	2720	2880	3040	3200
0.65	92	1472	1619	1766	1913	2060	2208	2355	2502	2649	2796	2944
0.70	86	1376	1513	1651	1788	1926	2064	2201	2339	2476	2614	2752
0.75	80	1280	1408	1536	1664	1792	1920	2048	2176	2304	2432	2560
0.80	75	1200	1320	1440	1560	1680	1800	1920	2040	2160	2280	2400
Bucket Payload Metric (Tons)		16.0	17.6	19.2	20.8	22.4	24.0	25.6	27.2	28.8	30.4	32.0

Wheel Loaders Integrated Toolcarriers

Production Estimating Table

- Shot Rock ● 60 min hour
- U.S. Tons

U.S. Tons ● 2700 lb/LCY (1.35 T) density

Bucket Size yd ³	1.0	1.5	2.0	2.5	3.0	3.5	4.0	4.5	5.0	5.5	6.0	6.5	7.0	7.5	8.0	8.5	9.0	9.5	10.0	
Cycle Time	Cycles Per Hr	Unshaded area indicates average production.																		
0.40	150	203	330	420	510	615	705	810												
0.45	133	180	293	360	454	545	625	720	810	905	985	1080	1170							
0.50	120	162	254	324	408	492	565	650	730	815	890	970	1060	1140	1200	1300	1380	1470	1540	1620
0.55	109	147	240	294	370	448	515	590	665	740	805	885	960	1030	1090	1180	1250	1330	1400	1740
0.60	100	135	220	270	340	410	470	540	610	680	740	810	880	950	1000	1080	1150	1220	1280	1350
0.65	92	124	200	250	314	380	435	500	560	625	680	750	810	875	920	985	1060	1120	1180	1250
0.70	86								525	585	635	695	755	815	860	930	990	1050	1100	1160
0.75	80													760	800	865	920	975	1030	1080
Bucket Payload (Tons)	1.35	2.2	2.7	3.4	4.1	4.7	5.4	6.1	6.8	7.4	8.1	8.8	9.5	10.0	10.8	11.5	12.2	12.8	13.5	

Bucket Size yd ³	11.0	12.0	13.0	14.0	15.0	16.0	17.0	18.0	19.0	20.0	21.0	22.0	23.0	24.0	25.0	26.0	
Cycle Time	Cycles Per Hr	Unshaded area indicates average production.															
0.40	150																
0.45	133																
0.50	120	1782	1945														
0.55	109	1620	1765	1905	2060	2200	2350	2495	2645	2790	2940	3080	3235	3375	3530	3670	3825
0.60	100	1485	1620	1750	1890	2020	2160	2290	2430	2560	2700	2830	2970	3100	3240	3370	3510
0.65	92	1365	1490	1610	1735	1855	1985	2105	2235	2355	2480	2600	2730	2850	2980	3100	3225
0.70	86	1275	1390	1505	1625	1735	1855	1965	2085	2200	2320	2430	2550	2665	2785	2895	3015
0.75	80	1190	1295	1400	1510	1615	1725	1830	1940	2045	2160	2260	2375	2480	2590	2695	2805
0.80	75			1310	1415	1515	1620	1715	1820	1920	2025	2120	2225	2325	2430	2525	2630
Bucket Payload (Tons)	14.9	16.4	17.5	18.9	20.2	21.6	22.9	24.3	25.6	27.0	28.3	29.7	31.0	32.4	33.7	35.1	

Attachments	903C	906K/M, 907K/M, 908K/M	910K	914K	924K, 926M	930K, 930M	938K, 938M	950K, 962K	950H, 962H	966H, 966K, 966M, 972H, 972K, 972M	980K, 980H	986H	988K	990K	992K	993K	994K
Fusion Quick Coupler					X	X	X	X	X	X							
Quick Coupler		X	X	X							X						
Performance Series General Purpose Bucket			X	X	X	X	X	X	X	X	X	X	X				
General Purpose Bucket	X	X							X	X	X						
Performance Series Material Handling Bucket								X	X	X	X						
Material Handling Bucket			X	X					X	X	X						
Sand & Gravel Bucket					X	X	X										
Performance Series Coal Bucket									X	X	X						
Coal Bucket			X	X					X	X	X			X	X	X	X
Performance Series Rock Bucket								X	X	X	X	X	X				
Rock Bucket									X	X	X			X	X	X	X
Performance Series Heavy Duty Rock Bucket											X	X	X	X			
Heavy Duty Rock Bucket											X			X	X		
Performance Series Heavy Duty Granite Bucket												X	X	X			
Heavy Duty Granite Bucket														X	X	X	
Heavy Abrasion Rock Bucket															X	X	
Iron Ore Bucket														X	X	X	
Serrated Edge Rock Bucket														X	X	X	
Multi-purpose Bucket	X	X						X	X	X							
Side Dump Bucket			X	X	X	X	X	X	X	X							
High Dump Bucket					X	X	X	X	X	X							
Grapple Bucket		X			X	X	X	X	X	X							
Waste Handling Bucket					X	X	X	X	X	X	X						
Woodchip Bucket			X	X	X	X	X	X	X	X	X						
Slag Bucket										X	X			X			
Fertilizer Bucket			X	X													
Grading Bucket					X	X	X										
Light Material Bucket	X	X	X	X	X	X	X										

NOTE: List is not all-inclusive. Contact your Cat dealer for special attachment needs.

Attachments	903C	906K/M, 907K/M, 908K/M	910K	914K	924K, 926M	930K, 930M	938K, 938M	950K, 962K	950H, 962H	966H, 966K, 966M, 972H, 972K, 972M	980K, 980H	986H	988K	990K	992K	993K	994K
Pallet Fork	X	X	X	X	X	X	X	X	X	X	X						
Construction Fork					X	X	X										
Log & Lumber Fork			X	X	X	X	X	X	X	X							
Logging Fork								X	X	X	X						
Millyard Fork							X	X	X	X	X		X	X			
Unloading Grapple Fork							X	X									
Pipe & Pole Fork						X	X	X	X	X							
Grapple Forks					X	X	X										
Asphalt Cutters					X	X											
Auger		X															
Blade			X	X						X							
Angle Broom		X	X	X	X	X	X	X	X								
Special Application Broom		X	X	X	X	X	X	X	X								
Pickup Broom		X	X	X	X	X	X										
Cold Planer		X															
Compactors		X															
Landscape Tillers		X															
Material Handling Arm		X	X	X	X	X	X	X	X	X	X						
Rake		X			X	X	X	X	X	X							
Reversible Plow			X	X	X	X	X	X	X	X	X						
V-plow			X	X		X	X	X	X	X							
Snow Blower		X															
Snow Push		X	X	X	X	X	X										
Stump Grinder		X															
Trencher		X															
Wheel Saw		X															
Block Handling Tools											X	X	X				

NOTE: List is not all-inclusive. Contact your Cat dealer for special attachment needs.

BUCKETS

Performance Series — optimized fill factors for use in truck loading, stockpiling and load-and-carry applications.

General Purpose — provide good all-around performance for stockpiling, re-handling, excavating and bank loading.

Material Handling — designed for efficient loading of stockpiled materials.

Coal — high-volume material movers, for loading and stockpiling coal and other materials of similar density.

Rock — designed for high production in abrasive applications.

Multi-Purpose — versatile ... loads, strips topsoil, bulldozes, clamps pipe, and cleans up debris, plus many other tasks.

Side Dump — dump forward or to the left ... ideal in tight quarters or to reduce turning time.

High Dump — for extended dump height of light materials.

Grapple — equipped with dual top clamps to grab and hold loose material.

Waste Handling — move large volumes for low-density refuse in transfer stations, landfills and recycling yards.

Woodchip — optimized for moving large volumes of wood chips.

Slag — heavy duty and specifically constructed to handle extreme conditions that come with handling hot slag.

FORKS

Pallet — for a variety of task, tines are adjustable and available in several different lengths.

Log & Lumber — flat tines and raised back are designed specifically for use in handling both unfinished logs and stack lumber. Available with top clamp.

Logging — equipped with two independent top clamps, for use loading and unloading trucks and feeding the mill.

Millyard — equipped with one-piece top clamp, built for moving, sorting and feeding the mill.

Unloading Grapple — short tines and large top clamp opening ideal for unloading logs from trucks.

Pipe & Pole — wide carriage, fixed tines and full width double-acting clamp are ideal for transporting, loading and unloading pipe.

AND MORE ...

Brooms — for street or job site cleanup, snow removal etc. Angle, Special Application and Pick-up models available.

Material Handling Arms — provides a tool that can pick, carry and load a variety of materials. Arm length can be adjusted.

Plows — ideal for snow clearing, available in angling and V-plow styles.

Rakes — versatile tools that work well in light-duty, medium-duty and heavy-duty land clearing situations. Available with top clamp.

Integrated Toolcarriers Attachments

Attachments	910K	914K
Performance Series		
General Purpose Bucket	X	X
General Purpose Bucket	X	X
Material Handling Bucket	X	X
Coal Bucket		
Multi-Purpose Bucket	X	X
Side Dump Bucket	X	X
High Dump Bucket		
Grapple Bucket		
Waste Handling Bucket		
Woodchip Bucket		
Pallet Fork	X	X
Log & Lumber Fork		
Logging Fork		
Millyard Fork		
Grapple Fork	X	X
Asphalt Cutter		
Straight Blade		
Angle Blade	X	X
Angle Broom	X	X
Special Application Broom		
Pick-up Broom		
Material Handling Arm	X	X
Reversible Plow		
V-plow		
One Way Plow		
Rake		

This list not all inclusive. Contact your Cat dealer for special attachment needs.

FUSION COUPLER SYSTEM

Caterpillar is breaking new ground with the Fusion Coupler System. Caterpillar engineers designed this new system to exceed the performance of any other Cat or competitive coupler solution in the marketplace. This coupler system is a factory- or field-installed option for Cat Loaders from 924K through 972, including IT38 and IT62 machines. Fusion offers benefits in four main categories:

Performance

This new, patented interface provides coupler flexibility with performance virtually identical to pin-on.

Imagine lifting a hundred-pound box with your arms fully extended. Now, imagine lifting that same load close to your body. That's the genius of Fusion: designed to integrate the attachment and the machine by pulling the coupler and tool closer to the wheel loader. As a result, the center of gravity is moved inward, towards the machine. This translates to increased lifting ability when compared to machines equipped with competing coupler systems.

Durability

The advanced wedging mechanism of the Fusion Coupler creates a tight, rattle-free fit. This new lock up system eliminates play and wear — resulting in a long service life.

Wedges pull the attachment tight to the machine in two directions — in and down. Constant hydraulic pressure on the coupler wedges compensate for wear, assuring a tight fit throughout the life of the coupler. Tight fit gives better tool control and increased productivity. Plus, coupler durability is substantially increased over traditional couplers.

Visibility

A new, open coupler frame design opens sight lines from the operator's seat, making it easier than ever before to engage and disengage attachments with certainty.

Offset tines and other design changes to Fusion Pallet Forks, working in conjunction with the Fusion Coupler, increase visibility substantially at ground level and truck bed height when compared to traditional coupler and fork combinations.

Flexibility/Compatibility

With the Fusion Coupler system, Caterpillar customers get **one common interface**. This unique, single interface eliminates the need for many different couplers across the entire range of Cat Small and Medium Wheel Loaders. This expanded machine compatibility not only allows one machine to pick up a range of attachments, but also for one attachment to be used by a host of different machines. Realize the flexibility and opportunity afforded your rental operation, or the improvements to machine and attachment management on your customers' job sites.

Fusion is supported by a full line of attachments. Just about any attachment available for pin-on is also available, or can be converted, to work with Fusion. For complete information on Fusion attachments available for Cat Loaders 924 through 972, consult Fusion Product Bulletin GEJQ0222.

Fusion Attachments	924K, 926M	930K, 930M	938K, 938M	950K, 962K	950H, 962H	IT62H/G	966K/H	972K/H
Performance Series General Purpose Bucket	X	X	X	X	X		X	X
General Purpose Bucket				X	X	X	X	X
Performance Series Material Handling Bucket	X	X	X	X			X	X
Material Handling Bucket				X	X	X	X	X
Performance Series Coal Bucket							X	X
Coal/Light Material Bucket					X	X	X	X
Performance Series Rock Bucket				X			X	X
Rock Bucket				X	X		X	X
Multi-purpose Bucket				X	X	X	X	X
Sand & Gravel Bucket	X	X	X	X	X	X	X	X
Side Dump Bucket	X	X	X	X	X	X	X	X
High Dump Bucket	X	X	X	X	X	X	X	X
Grapple Bucket	X	X	X	X	X	X	X	X
Waste Handling Bucket	X	X	X	X	X	X	X	X
Woodchip Bucket	X	X	X	X	X	X	X	X
Light Material Bucket	X	X	X					
Pallet Fork	X	X	X	X	X	X	X	X
Construction Fork	X	X	X					
Log & Lumber Fork	X	X	X	X	X	X	X	X
Logging Fork				X				
Millyard Fork	X	X	X	X				
Grapple Fork				X				
Pipe & Pole Fork	X	X	X	X	X		X	X
Sorting Grapple	X	X	X					
Angle Broom	X	X	X	X	X			
Special Application Broom	X	X	X	X	X			
Pickup Broom	X	X	X					
Material Handling Arm	X	X	X	X	X	X	X	X
Rake	X	X	X	X	X	X	X	X
Reversible Plow	X	X	X	X	X	X	X	X
V-plow				X	X		X	X

NOTE: This list is not all-inclusive. Contact your Cat dealer for special attachment needs.

WHEEL TRACTOR-SCRAPERS

CONTENTS

WHEEL TRACTOR-SCRAPERS

Specifications:		
Elevating Bowl	24-2	
Single Engine Open Bowl	24-3	
Optional Push-Pull	24-3	
Twin Engine Open Bowl	24-4	
Optional Push-Pull	24-4	
Coal Bowl	24-6	
Ground Engaging Tools:		
Router Bits	24-7	
Cutting Edges	24-7	
Bowl Side Protectors	24-9	
Elevating Scraper	24-9	
K Series Features and Benefits	24-10	
Material Application Guide	24-12	
Push-Load TTT Match	24-12	
Tire Options, All Models		24-13
Cushion Hitch		24-14
Wheel Tractor-Scraper Anatomy		24-14
Use of Rimpull-Speed-Gradeability Curves		24-15
Fixed Times for Scrapers		24-17
Use of Retarder Curves		24-17
Curves/Charts:		
621K Rimpull, Retarding		24-19
623K Rimpull, Retarding		24-21
627K Rimpull, Retarding		24-23
631K Rimpull, Retarding		24-25
637K Rimpull, Retarding		24-27
657G Rimpull, Retarding		24-29

MODEL	623K	
Flywheel Power	304 kW	407 hp
Approx. Operating Weight (Empty)◀	39 866 kg	87,809 lb
Scraper Capacity: Struck	14.4 m ³	18.8 yd ³
Heaped	17.6 m ³	23 yd ³
Rated Load	25 038 kg	55,200 lb
Weight Distribution — Empty:		
Drive	63%	
Rear	37%	
Weight Distribution — Loaded:		
Drive	52%	
Rear	48%	
Engine Model	C13 ACERT™	
Emission Standards	Tier 4 Final/Stage IV/Japan 2014 (Tier 4 Final)	
Rated Engine RPM	2000	
Displacement	12.5 L	763 in ³
Top Speed (Loaded)	53.9 km/h	33.5 mph
180° Curb-to-Curb Turning Width	12.96 m	42'6"
Tires — Standard:		
Tractor/Scraper	33.25R29★E3	
Width of Cut	3.14 m	10'4"
Maximum Depth of Cut	262 mm	10.3"
Elevator Flight Spacing	520 mm	20"
Number of Flights	15	
Maximum Floor Opening	1.34 m	4'4"
Maximum Depth of Spread	465 mm	18'3"
Fuel Tank Refill Capacity	763 L	201 U.S. gal
Tractor DEF Tank	31.5 L	8.3 U.S. gal
GENERAL DIMENSIONS:		
Height — Overall Shipping	3.77 m	12'3"
Wheelbase	8.37 m	27'5"
Overall Length	13.77 m	45'2"
Overall Width	3.57 m	11'7"
Center Line of Scraper Tread	2.29 m	7'5"
Center Line of Tractor Tread	2.28 m	7'4"

◀ Operating weight includes coolants, lubricants, full fuel tank and operator. Operating weights for the 623K are based on U.S. EPA Tier 4 Final/EU Stage IV/Japan 2014 (Tier 4 Final) platform machines. Deduct 243 kg (536 lb) for the operating weight for the 623K Tier 2/Stage II/Japan 2001 (Tier 2) equivalent.

NOTE: Wheel Tractor-Scrapers are not certified for Japan market.

Elevating

The Elevating Wheel Tractor-Scraper is a self-loading hauling system with the added ability to mix/homogenize material and do precise finishing work.

Elevating Bowl Advantages:

- Load/haul/spread with little support equipment
- Conditions material as it loads
- Capable to work as a single machine
- Aids in compaction
- Finishing work
- Low rolling resistance applications
- Short cut areas
- Favorable material types
- Windrow applications
- Thin, precise lifts

Single Engine Advantages

(Compared to Tandem Engine):

- Lower fuel usage
- Lower gross vehicle weight

Specifications
 ● Single Engine Open Bowl
 ● Optional Push-Pull

Wheel Tractor-Scrapers

MODEL	621K		631K	
Flywheel Power	304 kW	407 hp	425 kW	570 hp
Approx. Operating Weight (Empty)◀	35 808 kg	78,943 lb	46 600 kg	102,750 lb
Scraper Capacity: Struck	13 m ³	17.1 yd³	18.3 m ³	24 yd³
Heaped	18.4 m ³	24 yd³	26 m ³	34 yd³
Rated Load	26 127 kg	57,610 lb	37 285 kg	82,200 lb
Weight Distribution — Empty:				
Drive		65%		67%
Rear		35%		34%
Weight Distribution — Loaded:				
Drive		53%		54%
Rear		47%		46%
Engine Model	C13 ACERT		C18 ACERT	
Emission Standards	Tier 4 Final/Stage IV/ Japan 2014 (Tier 4 Final)		Tier 4 Final/Stage IV/ Japan 2014 (Tier 4 Final)	
Rated Engine RPM	2000		1900	
Displacement	12.5 L	763 in³	18.1 L	1105 in³
Top Speed (Loaded)	53.9 km/h	33.5 mph	55.8 km/h	34.7 mph
180° Curb-to-Curb Turning Width	11.8 m	38'7"	12.2 m	40'2"
Tires — Tractor/Scraper	33.25R29**E3		37.25R35**E3	
Width of Cut	3.14 m	10'4"	3.51 m	11'6"
Maximum Depth of Cut	315 mm	12.4"	475 mm	18.7"
Maximum Depth of Spread	540 mm	21.3"	451 mm	17.8"
Fuel Tank Refill Capacity	763 L	201 U.S. gal	874 L	231 U.S. gal
Tractor DEF Tank	31.5 L	8.3 U.S. gal	31.5 L	8.3 U.S. gal
GENERAL DIMENSIONS: Non Push-Pull				
Height — Overall Shipping	4.03 m	13'2"	3.89 m	12'9"
Wheelbase	7.99 m	26'2"	8.81 m	28'11"
Overall Length	14.02 m	45'10"	15.04 m	49'4"
Overall Width	3.57 m	11'7"	3.94 m	12'11"
Center Line of Scraper Tread	2.29 m	7'5"	2.46 m	8'1"
Center Line of Tractor Tread	2.28 m	7'4"	2.46 m	8'1"
GENERAL DIMENSIONS: Push-Pull				
Operating Weight (Empty)	37 154 kg	81,910 lb	48 275 kg	106,430 lb
Overall Length (With Bail Down)	15.58 m	51'1"	16.64 m	54'7"
Weight Distribution — Empty:				
Drive		65%		68%
Rear		35%		32%
Weight Distribution — Loaded:				
Drive		53%		55%
Rear		47%		45%

◀ Operating weight includes standard machine, coolant, lubricants, full fuel tank, and operator. Operating weights for the 621K and 631K are based on Tier 4 Final/Stage IV/Japan 2014 (Tier 4 Final) platform machines. Deduct 243 kg (**536 lb**) for the operating weight for the 621K Tier 2/Stage II/Japan 2001 (Tier 2) equivalent. Deduct 430 kg (**950 lb**) for the operating weight for the 631K Tier 2/Stage II/Japan 2001 (Tier 2) equivalent.

NOTE: Wheel Tractor-Scrapers are not certified for Japan market.

Single Engine Open Bowl

The Open Bowl Wheel Tractor-Scraper is available as a self-loading, 631K push pull or push-loaded hauling system with a broad material appetite. The broad material appetite allows the Open Bowl Wheel Tractor-Scraper to be used in general construction, heavy construction, mining, and waste applications.

Open Bowl Advantages:

- Quick load/unload
- Spread evenly on-the-go
- Broad material appetite
- Aids in compaction
- Varying material conditions
- High production

Single Engine Advantages

(Compared to Tandem Engine):

- Lower fuel usage
- Lower gross vehicle weight
- Loads quickly with the aid of a Track-Type Tractor and hauls to fill carrying minimum machine weight

Wheel Tractor-Scrapers

Specifications

- Twin Engine Open Bowl
- Optional Push-Pull

MODEL	627K		637K		657G	
Flywheel Power: Tractor	304 kW	407 hp	425 kW	570 hp	421/447 kW	564/600 hp
Scraper	216 kW	290 hp	216 kW	290 hp	306/337 kW	410/451 hp
Approx. Operating Weight (Empty)◀	40 811 kg	89,973 lb	52 140 kg	114,950 lb	68 384 kg	150,760 lb
Scraper Capacity: Struck	13 m ³	17.1 yd³	18.3 m ³	24 yd³	24.5 m ³	32 yd³
Heaped	18.4 m ³	24 yd³	26 m ³	34 yd³	33.6 m ³	44 yd³
Rated Load	26 127 kg	57,610 lb	37 285 kg	82,200 lb	47 174 kg	104,000 lb
Weight Distribution — Empty: Front		59%		59%		58%
Rear		41%		41%		42%
Weight Distribution — Loaded: Front		50%		50%		50%
Rear		50%		50%		50%
Engine Model: Tractor	C13 ACERT		C18 ACERT		C18 ACERT	
Scraper	C9.3 ACERT		C9 ACERT		C15 ACERT	
Emission Standards	Tier 4 Final/Stage IV/ Japan 2014 (Tier 4 Final)		Tier 4 Final/Stage IV/ Japan 2014 (Tier 4 Final)		Tier 3/Stage IIIA/ Japan 2006 (Tier 3) equivalent	
Rated Engine RPM: Tractor	2000		1900		1800	
Scraper	2150		2150		1800	
Displacement: Tractor	12.5 L	763 in³	18.1 L	1105 in³	18.1 L	1105 in³
Scraper	9.3 L	567 in³	9.3 L	567 in³	15.2 L	928 in³
Top Speed (Loaded)	53.9 km/h	33.5 mph	55.8 km/h	34.7 mph	53 km/h	33 mph
180° Curb-to-Curb Turning Width	11.8 m	38'7"	12.2 m	40'2"	14.2 m	46'7"
Tires — Tractor/Scraper	33.25R29**E3		37.25R35**E3		40.5/75R39**E3	
Width of Cut	3.14 m	10'4"	3.51 m	11'6"	3.85 m	12'8"
Maximum Depth of Cut	315 mm	12.4"	475 mm	18.7"	440 mm	17.3"
Maximum Depth of Spread	540 mm	21.3"	451 mm	17.8"	660 mm	26"
Fuel Tank Refill Capacity	1272 L	336 U.S. gal	1400 L	370 U.S. gal	1597 L	424 U.S. gal
Tractor DEF Tank	31.5 L	8.3 U.S. gal	31.5 L	8.3 U.S. gal		—
Scraper DEF Tank	23.1 L	6.1 U.S. gal	22.9 L	6.0 U.S. gal		—
GENERAL DIMENSIONS:						
Non Push-Pull						
Height — Overall Shipping	4.03 m	13'2"	4.15 m	13'7"	4.62 m	15'2"
Wheelbase	7.99 m	26'2"	8.81 m	28'11"	9.96 m	32'8"
Overall Length	14.02 m	45'10"	15.04 m	49'4"	16.2 m	53'1"
Overall Width	3.57 m	11'7"	3.94 m	12'11"	4.35 m	14'4"
Shipping Width (Draft Arm on Inside of Bowl)		—		—	3.91 m	* 12'10"
Center Line of Scraper Tread	2.29 m	7'5"	2.46 m	8'1"	2.81 m	9'3"
Center Line of Tractor Tread	2.28 m	7'4"	2.46 m	8'1"	2.63 m	8'8"
GENERAL DIMENSIONS: Push-Pull						
Operating Weight (Empty)◀	42 158 kg	92,942 lb	54 005 kg	119,060 lb	72 804 kg	160,505 lb
Overall Length	15.58 m	51'1"	16.64 m	54'7"	18.01 m	59'1"
Weight Distribution — Empty:						
Front		59%		61%		58%
Rear		41%		39%		42%
Weight Distribution — Loaded:						
Front		50%		51%		51%
Rear		50%		49%		49%

*Standard Shipping Configuration.

◀ Operating weight includes standard machine, coolant, lubricants, full fuel tank, and operator. Operating weights for the 627K and 637K are based on Tier 4 Final/Stage IV/Japan 2014 (Tier 4 Final) platform machines. Deduct 569 kg (**1254 lb**) for the operating weight for the 627K Tier 2/Stage II/Japan 2001 (Tier 2) equivalent. Deduct 650 kg (**1433 lb**) for the operating weight for the 637K Tier 2/Stage II/Japan 2001 (Tier 2) equivalent. 657G is not available in Tier 2/Stage II/Japan 2001 (Tier 2) equivalent.

NOTE: Wheel Tractor-Scrapers are not certified for Japan market.

- Specifications
- Twin Engine Open Bowl
 - Optional Push-Pull

Twin Engine Open Bowl

The Open Bowl Wheel Tractor-Scraper is available as a self-loading, push-loaded, or push-pulled hauling system with a broad material appetite. The broad material appetite allows the Open Bowl Wheel Tractor-Scraper to be used in general construction, heavy construction, mining, and waste applications.

Open Bowl Advantages:

- Quick load/unload
- Spread evenly on-the-go
- Broad material appetite
- Aids in compaction
- High Production
- Varying material conditions
- High production

Twin Engine Advantages

(Compared to Single Engine):

- More power for loading, traveling up grades, or over fill area
- Faster cycle times
- High rolling resistance applications
- Variable site conditions
- Poor underfoot conditions
- Steep grades
- Can be self-loaded, push loaded with the aid of a Track-Type Tractor, or push-pulled

MODEL	637K		657G	
Flywheel Power: Tractor	425 kW	570 hp	421/447 kW	564/600 hp
Scraper	216 kW	290 hp	306/337 kW	410/451 hp
Approx. Operating Weight (Empty)	53 425 kg	117,782 lb	72 190 kg	158,817 lb
Scraper Capacity: Struck	31 m ³	41 yd³	45 m ³	59 yd³
Heaped	38 m ³	50 yd³	56 m ³	73 yd³
Emission Standards	Tier 4 Final/Stage IV/ Japan 2014 (Tier 4 Final)		Tier 3/Stage IIIA/ Japan 2006 (Tier 3) equivalent	
Rated Load	37 285 kg	82,200 lb	49 895 kg	110,000 lb
Approx. Operating Weight (Loaded)	90 710 kg	199,982 lb	121 933 kg	268,817 lb
Top Speed (Loaded)	55.8 km/h	34.7 mph	53 km/h	33 mph
180° Curb-to-Curb Turning Width	12.98 m	42'7"	15.6 m	51'3"
GENERAL DIMENSIONS:				
Height — Overall Shipping	4.15 m	13'7"	4.62 m	15'2"
Wheelbase	9.57 m	31'5"	11.01 m	36'1"
Overall Length	15.48 m	50'10"	17.21 m	56'5"
Overall Width	3.94 m	12'11"	4.35 m	14'4"
Shipping Width (Draft Arm on Inside of Bowl)		—	3.91 m	* 12'10"
Center Line of Scraper Tread	2.46 m	8'1"	2.81 m	9'3"
Center Line of Tractor Tread	2.46 m	8'1"	2.63 m	8'8"

*Standard Shipping Configuration.

◀ Operating weight includes standard machine, coolant, lubricants, full fuel tank, and operator. Operating weights for the 637K are based on Tier 4 Final/Stage IV/Japan 2014 (Tier 4 Final) and operating weights for the 657G are based on Tier 3/Stage IIIA/Japan 2006 (Tier 3) equivalent platform machines. Deduct 650 kg (1433 lb) for the operating weight for the 637K Tier 2/Stage II/Japan 2001 (Tier 2) equivalent.

NOTE: Wheel Tractor-Scrapers are not certified for Japan market.

Coal Bowl

Coal Bowl Wheel Tractor-Scrapers are typically used for building and maintaining coal stockpiles and hauling coal to the supply system at coal power plants. The self-loading capability, large capacity, coal pile compaction, and high speed of Coal Bowl Wheel Tractor-Scrapers make them the tool of choice for moving coal both short and long distances. Coal Bowl Wheel Tractor-Scrapers are available in the 637K and 657G tandem engine models.

Coal Bowl Advantages:

- Load hoppers
- Manage coal stockpiles
- Compaction reduces risk of spontaneous combustion in coal stockpile
- Exclusively designed large capacity coal bowls

Notes:

- The 637K Coal Scraper is 736 mm (29.0") longer, the bowl sides are 476 mm (18.7") taller, and the apron is 499 mm (19.6") taller than its earthmoving counterpart.
- The 657G Coal Scraper is 1072 mm (42.2") longer, the bowl sides are 1010 mm (39.8") taller, the apron is 677 mm (26.7") taller, and the ejector is 944 mm (37.2") taller than its earthmoving counterpart.

- Router Bits
- Cutting Edges

WHEEL TRACTOR-SCRAPER GROUND ENGAGING TOOLS

ROUTER BITS

Cat® router bits help prevent wear and costly damage to the scraper bowl. All router bits are forged DH-2 steel and through-hardened to prevent breakage and prolong life.



Standard Router Bit

- Available for all models.



Heavy Duty Router Bit

- 45% more wear material than the standard router bits.



ARM Router Bit

- Available for virtually all models in high abrasion, low impact applications.



Level Router Bit

- Used for clean-up work and keeps material in front of the cutting edges.

CUTTING EDGES

Cat cutting edges are rolled from DH-2 steel and through-hardened for strength and wear resistance and are available in standard, abrasion resistant material (ARM), and serrated versions.



Standard center and end-cutting edges

- For use on all scraper models (open bowl, auger and elevating scraper).
- Used in low-to-medium abrasion and low-to-high impact conditions.
- Available in various thicknesses and sizes for both stinger and level-cut arrangements.
- Can be reversed or propellered for prolonged edge use and improved cost per hour.



ARM center and end cutting edges

- For use on all scraper models (open bowl, auger and elevating scraper).
- Used in medium-to-high abrasion and low-to-high impact conditions.
- Available in various thicknesses and sizes for both stinger and level-cut arrangements.
- Can be reversed or propellered for prolonged edge use and improved cost per hour.



ARM serrated center cutting edge

- For use on 620, 630 and 650 Series Scraper (open bowl, auger and elevating scraper).
- Used in medium-to-high abrasion and medium-to-high impact conditions where increased penetration and aggressive digging action is required.
- Available in various thicknesses and sizes for both stinger and level-cut arrangements.
- Edges can be reversed or propellered around for prolonged edge use and improved cost per hour.



Special serrated cutting edges

- For site-specific applications and conditions.
- Use on 620, 630 and 650 Series Scraper (open bowl, auger and elevating scraper).
- Custom-designed edges have sharp teeth for low-to-medium abrasion and low-to-medium impact conditions.



Integrated tooth center cutting edge

- For use on 623 and 633 Elevating Scraper, and 620 Series Auger Scraper.
- Used in low-to-high abrasion conditions for improved penetration in medium-to-high impact conditions.
- Include cast-in-place adapters, which accept pin-on tips.



Bolt-on adapters

- For use on Elevating Scraper 613, 615, 623 and 633.
- Used in low-to-high abrasion conditions and low-to-medium impact conditions when improved penetration is needed.
- Bolt-on adapters accept pin-on tips.

- Bowl Side Protectors
- Elevating Scraper

BOWL SIDE PROTECTORS

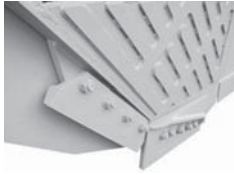

- Bowl Side protectors are available in two styles: Bolt on bowl side protectors and pin on bowl side protectors.
- Bolt on style takes a weld on adapter plate that accepts the bolt on bowl side protector. This is available for 620, 630 and 650 Series scrapers.
- Pin on style takes a weld on adapter plate that accepts the pin on bowl side protector. This is available for 620, 630 and 650 Series scrapers.

ELEVATING SCRAPER



- Flight assemblies.
- Chain assemblies.*
- Sprockets.*
- Idlers and idler groups.
- Rollers and roller groups.

*Optional heavy-duty chain and sprocket for 623K available through your Cat dealer.

In today's competitive environment, machines must operate efficiently. Inspections identify problems that cause machines to burn more fuel and shorten component life.

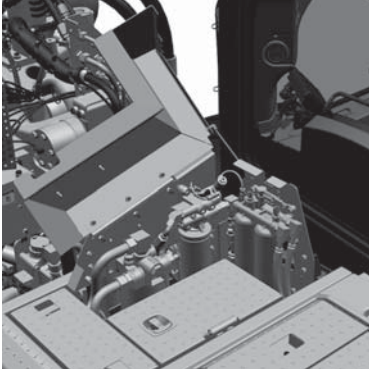
K SERIES FEATURES AND BENEFITS



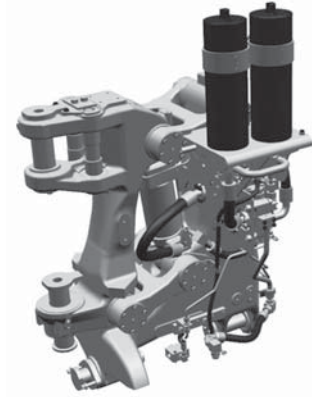



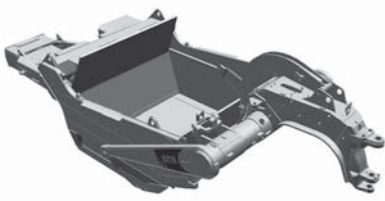























































- **Tractor Serviceability Improvement** — The filter bank located at the rear of the engine compartment has undergone improvements for serviceability by raising the filter bank up for easier access.
- **Engine Over Speed Protection** — In the event of an engine over speed situation, the compression brake will automatically engage with no operator input. The machine determines the over speed condition based on rate of acceleration and applies compression brake automatically.
- **Fuel Economy Mode** — Fuel Economy Mode is a two part feature when selected, the first part of the feature lowers the transmission shift points allowing shifting to take place at lower rpms to aid in fuel savings. The second part of the Fuel Economy Mode allows the machine when operated at engine rpms less than full throttle to automatically vary the power distribution between the tractor and the scraper, allowing the machine to utilize the more efficient tractor power train vs. the full time torque converter drive scraper power train.













- **Advanced Cushion Hitch** — With similar technology as the Cat Advanced Ride Management seat suspension, this software allows the cushion hitch to prevent end stroke by having the ability to predict end stroke events and manage the rate of dampening. The desired result is improved hitch repair, reduced maintenance and improved operator ride in rough conditions.
- **High Pressure Steering** — The K Series steering system design requires significantly less steering effort. The reduced steering effort allows for decreased operator fatigue and a more efficient operator resulting in possible higher rates of production late in the work cycle.

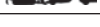

- **Draft Arm Overflow Guards** — The open bowls now come standard with bowl side overflow guards to help prevent material from flowing over the bowl sides and falling onto the draft arms where material becomes lodged between the bowl side and draft arm resulting in decreased work cycle times.
- **Auto Stall** — In cold weather conditions the machine will use the Auto Stall feature to help warm up the transmission oil faster resulting in the machine shifting out of torque converter drive (2nd gear) faster than on previous models.
- **Differential Lock Engagement Protection (Standard)** — This standard feature allows the machine to prevent the operator from engaging the differential lock when damage could occur.
- **Cab Improved** — The interior of the K Series cabs has improved the operator comfort and visibility by redesigning the dash area and key pad placement.
- **Machine Speed Limit** — This feature is designed to take the place of top gear selection. If the machine top speed needs to be limited the operator can select the top speed through the display or the top speed can be set in ET. This will allow the machine to find the correct gear that works best for the engine and transmission. Allowing the engine and transmission to select the correct gear to pull the load in most cases resulting in a lower engine load factor and lower fuel burn verses using top gear selection that required the machine to run at engine speeds at or close high idle.
- **Ground Speed Control** — Ground Speed Control sets the desired top speed by the operator if job site conditions or segment speed limits require a speed less than full run out. Machine Speed Limit is intended for use when top speed needs to be limited for longer durations and Ground Speed Control is intended for use when the top speed needs to be reduced for shorter segments or intermediate periods of time. The operator can set the desired top speed and the machine will find the correct gear that works best for the engine and transmission. Allowing the engine and transmission to select the correct gear to pull the load in most cases will result in a lower engine load factor and lower fuel burn verses top gear selection.

Material Application Guide	Elevator	Self-Load Single and Tandem Engine	Push-Load Single and Tandem Engine	Push Pull	Auger Tandem Engine	Coal Bowl	Remarks
Decomposed Granite/Soil							Excellent loading
Decomposed Granite (Ripped)							Excellent loading by push-loading or push-pull to reduce cutting of tires
Moist Top Soil							Good to Excellent Loading
Top Soil							Excellent for WTS
Clay/Sand Mixture							Excellent for WTS
Sand							Good to Excellent loading, but some cases may need to be push loaded by a TTT or Push-Pull
Antigo							Excellent WTS material: lower portion may require ripping depending on material density
Coal							Excellent for WTS: ripping may be required in dense material
Limestone							In natural state, not suitable for WTS
Granite							Not suitable for WTS
Sandstone							For WTS to be productive in sandstone, material needs to be ripped. In some cases where density is high, WTS would not be a good fit
Shot Rock							Below 610 mm (24") good for WTS when push-loaded by a TTT to reduce cutting of tires
Loess Overtill (Banked)							Excellent for WTS: ripping may be required in dense material
Loess Overtill (Ripped)							Excellent WTS material provided rock size does not exceed 610 mm (24")
Aridisols							Excellent WTS material, ripping will decrease load times
Glacial Outwash/River Rock							Excellent WTS material provided rock size does not exceed 610 mm (24")

FOR MORE INFORMATION ON WHEEL TRACTOR-SCRAPER MATERIAL APPLICATIONS REFERENCE PUBLICATION AEXQ0442.

Push-Load TTT Match	D8	D9	D10	D11
621				
627				
631				
637				
657				

MODEL TIRE SIZE	PLY RATING/ STAR RATING*	TYPE
621K	★★	E-3
623K		
33.25R29◀	★★	E-3
33.25-29	32	E-3
627K		
33.25R29◀	★★	E-3

MODEL TIRE SIZE	PLY RATING/ STAR RATING*	TYPE
631K		
637K		
37.25R35◀	★★	E-3
657G		
40.5/75R39◀	★★	E-3

*Manufacturer uses star (★) rating system instead of ply rating.

◀Recommended tire.

CUSHION HITCH

- Cushion Hitch dampens shocks to provide a smoother ride
- Nitrogen over oil accumulators absorb and dampen road shock

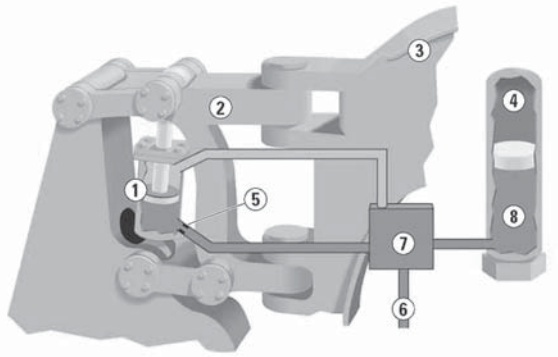

1. Load Cylinder
2. Hitch Castings
3. Scraper Gooseneck
4. Nitrogen Accumulators
5. Orifice
6. Oil from Tractor Hydraulic System
7. Leveling Valve
8. Free-Floating Pistons

WHEEL TRACTOR-SCRAPER ANATOMY

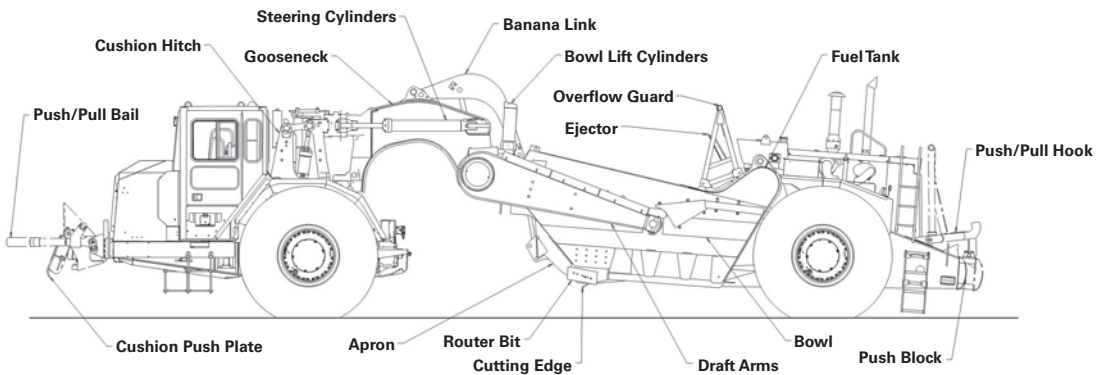

USE OF RIMPULL-SPEED-GRADEABILITY CURVES

The following explanation applies to Rimpull-Speed-Gradeability curves for Wheel Tractor-Scrapers, Construction & Mining Trucks/Tractors and Articulated Trucks.

Maximum speed attainable, gear range and available rimpull can be determined from curves on the following pages when machine weight and total effective grade (or total resistance) are known.

Rimpull is the force (in kg, lb or kN) available between the tire and the ground to propel the machine (limited by traction).

Weight is defined as Gross Machine Weight (kg or lb) = Machine + Payload.

Total Effective Grade (or Total Resistance) is grade resistance plus rolling resistance expressed as percent grade.

Grade is measured or estimated.

Rolling resistance is estimated (see Tables section for typical values.)

10 kg/metric ton (20 lb/U.S. ton) = 1% adverse grade.

Example

With a 6% grade and a rolling resistance of 40 kg/metric ton (80 lb/U.S. ton), find total resistance.

Rolling resistance = 40 kg/t ÷ 10 = 4% Effective Grade
 (English: 80 lb ÷ 20 = 4%)

Total resistance = 4% rolling + 6% grade = 10%

Altitude Derating

Rimpull force and speed must be derated for altitude similar to flywheel horsepower. The percentage loss in rimpull force approximately corresponds to the percentage loss in flywheel horsepower. See Tables Section for altitude derations.

Rimpull-Speed-Gradeability

To determine gradeability performance: Read from gross weight down to the % of total resistance. (Total resistance equals actual % grade *plus* 1% for each 10 kg/metric ton (20 lb/U.S. ton) of rolling resistance.) From this weight-resistance point, read horizontally to the curve with the highest obtainable speed range, then down to the maximum speed. Usable rimpull depends upon traction and weight on drive wheels.

Example problem:

A 631K with an estimated payload of 37 013 kg (81,600 lb) is operating on a total effective grade of 10%. Find the available rimpull and maximum attainable speed.

Empty weight payload = Gross Weight
 47 628 kg + 37 013 kg = 84 641 kg
 (105,002 lb + 81,600 lb = 186,602 lb)

Solution: Using graph on the next page, read from 84 641 kg (186,602 lb) (point A) on top of gross weight scale down the line to the intersection of the 10% total resistance line (point B).

Go across horizontally from B to the Rimpull Scale on the left (point D). This gives the required rimpull: 7756 kg (17,100 lb).

Where the line cuts the speed curve (point C), read down vertically (point E) to obtain the maximum speed attainable for the 10% effective grade: 12.9 km/h (8 mph).

ANSWER: The machine will climb the 10% effective grade at a maximum speed of 12.9 km/h (8 mph) in 4th gear. Available rimpull is 7756 kg (17,100 lb).



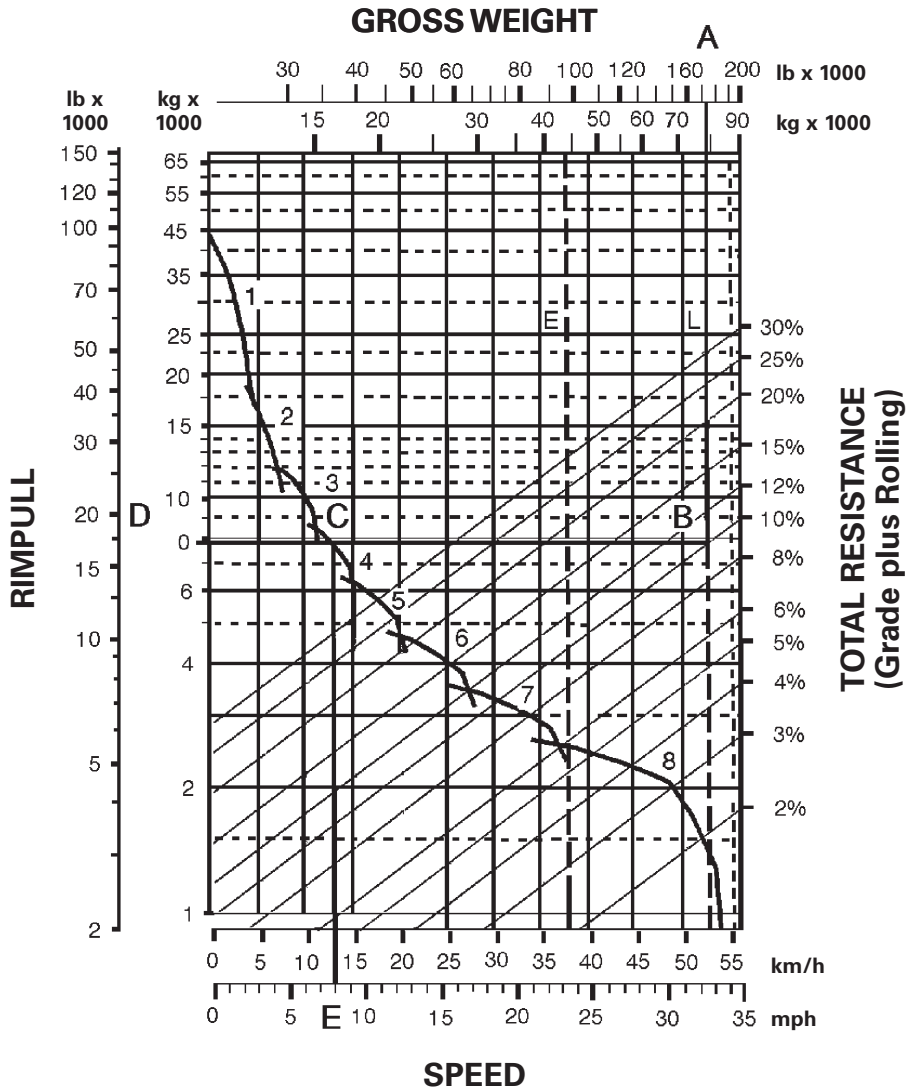

KEY

- 1 — 1st Gear Torque Converter Drive
- 2 — 2nd Gear Torque Converter Drive
- 3 — 3rd Gear Direct Drive
- 4 — 4th Gear Direct Drive
- 5 — 5th Gear Direct Drive
- 6 — 6th Gear Direct Drive
- 7 — 7th Gear Direct Drive
- 8 — 8th Gear Direct Drive

KEY

- A — Loaded 84 641 kg (186,602 lb)
- B — Intersection with 10% total resistance line
- C — Intersection with rimpull curve (4th gear)
- D — Required rimpull 7756 kg (17,100 lb)
- E — Speed 12.9 km/h (8 mph)

TYPICAL FIXED TIMES FOR SCRAPERS

(Times may vary depending on job conditions)

Model	Loaded By	Load Time (Min.)	Maneuver and Spread or Maneuver and Dump (Min.)
613G	Self	0.9	0.7
623K	Self	0.9	0.7
621K	One D8	0.5	0.7
627K	One D8	0.5	0.6
621K	One D9	0.4	0.7
627K	One D9	0.4	0.6
627K/PP	Self	0.9*	0.6
631K	One D9	0.6	0.7
637K	One D9	0.6	0.6
631K	One D10	0.5	0.7
637K	One D10	0.5	0.6
637K/PP	Self	1.0*	0.6
657G	One D11	0.6	0.6
657G	Push Pull Self	1.1*	0.6
637K	Coal	0.8	0.7
657G	Coal	0.8	0.6

*Load time per pair, including transfer time.

NOTE: Empty Weights shown on the Wheel Tractor-Scraper charts includes ROPS Canopy. The travel times will remain within acceptable limits when applied to a non-ROPS equipped machine. When calculating TMPH loadings *any* additional weight must be considered in establishing mean tire loads.

USE OF RETARDER CURVES

The following explanation applies to retarder curves for Wheel Tractor-Scrapers and Articulated Trucks.

The speed that can be maintained (without use of service brake) when the machine is descending a grade with retarder fully on can be determined from the retarder curves in this section if gross machine weight and total effective grade are known.

Total Effective Grade (or Total Resistance) is grade assistance *minus* rolling resistance.

10 kg/metric ton (20 lb/U.S. ton) = 1% adverse grade.

Example

15% favorable grade with 5% rolling resistance. Find Total Effective Grade.

$$\text{Total Effective Grade} = 15\% \text{ Grade Assistance} - 5\%$$

$$\text{Rolling Resistance} = 10\% \text{ Total Effective Grade Assistance.}$$

Example problem:

A 651E with an estimated payload of 47 175 kg (104,000 lb) descends a 10% total effective grade. Find constant speed and gear range with maximum retarder effort. Find travel time if the slope is 610 m (2000 ft) long.

$$\begin{aligned} \text{Empty Weight} + \text{Payload} &= \text{Gross Weight} \\ &= 60\,950 \text{ kg} + 47\,175 \text{ kg} = 108\,125 \text{ kg} \\ &= (134,370 \text{ lb} + 104,000 \text{ lb} = 238,370 \text{ lb}) \end{aligned}$$

Solution: Using the retarder curve below, read from 108 125 kg (238,370 lb) (point A) on top of gross weight scale down the line to the intersection of the 10% effective grade line (point B).

Go across horizontally from point B to the intersection of the retarder curve (point C). Point C intersects at the 5 (5th gear) range.

Where point C intersects the retarder curve, read down vertically to point D on the bottom scale to obtain the constant speed: 21.7 km/h (13.5 mph).

ANSWER: The 651E will descend the slope at 21.7 km/h (13.5 mph) in 5th gear. Travel time is 1.68 minutes.

$$\frac{610 \text{ m}}{363 \text{ m/min}} = 1.68 \text{ min}$$

*(mph × 88 = F.P.M.)

$$\frac{2000 \text{ ft}}{13.5 \text{ mph} \times 88^*} = 1.68 \text{ min}$$

NOTE: The basic Distance-Speed-Time formula is $60 D \div S = T$ (or “60 D Street”), where 60 is minutes, D is distance, S is speed and T is time. In the above problem, $60 \times 610 \text{ m} \div 21.7 \text{ km/h} \times 1000 = T$.

$$\frac{60 \times 610}{21.7 \times 1000} = T = (1.68)$$

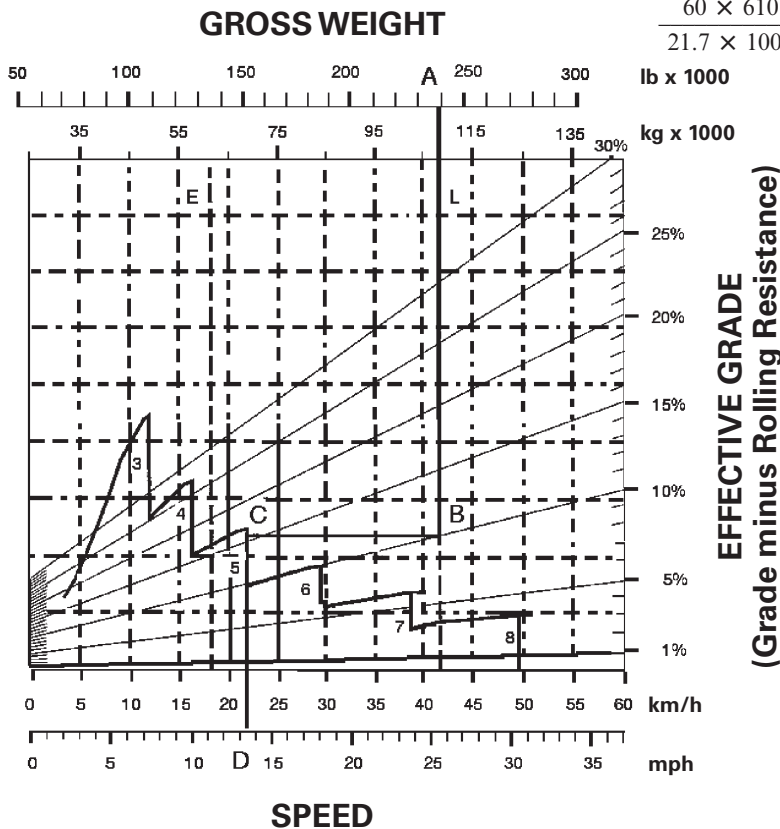

KEY

- 3 — 3rd Gear Direct Drive
- 4 — 4th Gear Direct Drive
- 5 — 5th Gear Direct Drive
- 6 — 6th Gear Direct Drive
- 7 — 7th Gear Direct Drive
- 8 — 8th Gear Direct Drive

KEY

- A — Loaded 108 125 kg (238,370 lb)
- B — Intersection with 10% effective grade line
- C — Intersection with retarder curve (5th gear)
- D — Constant speed 21.7 km/h (13.5 mph)

**STANDARD ARRANGEMENT*
 GROSS WEIGHT**

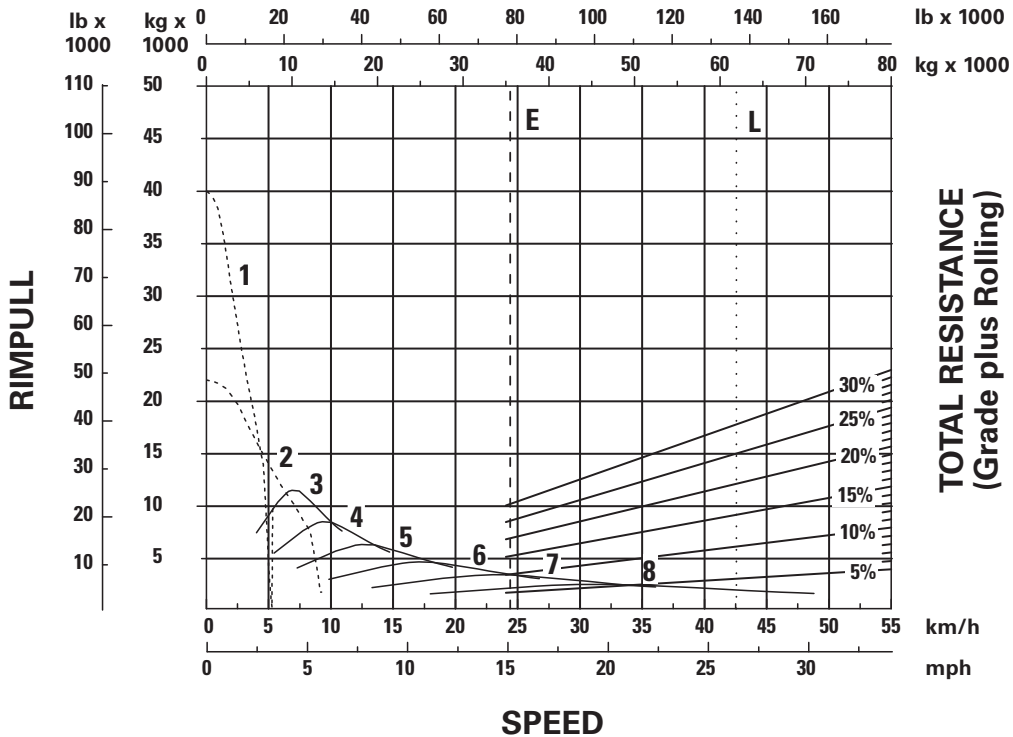

*at sea level

KEY

- 1 — 1st Gear Torque Converter Drive
- 2 — 2nd Gear Torque Converter Drive
- 3 — 3rd Gear Direct Drive
- 4 — 4th Gear Direct Drive
- 5 — 5th Gear Direct Drive
- 6 — 6th Gear Direct Drive
- 7 — 7th Gear Direct Drive
- 8 — 8th Gear Direct Drive

KEY

- E — Empty 35 808 kg (78,943 lb)
- L — Loaded 61 935 kg (136,553 lb)

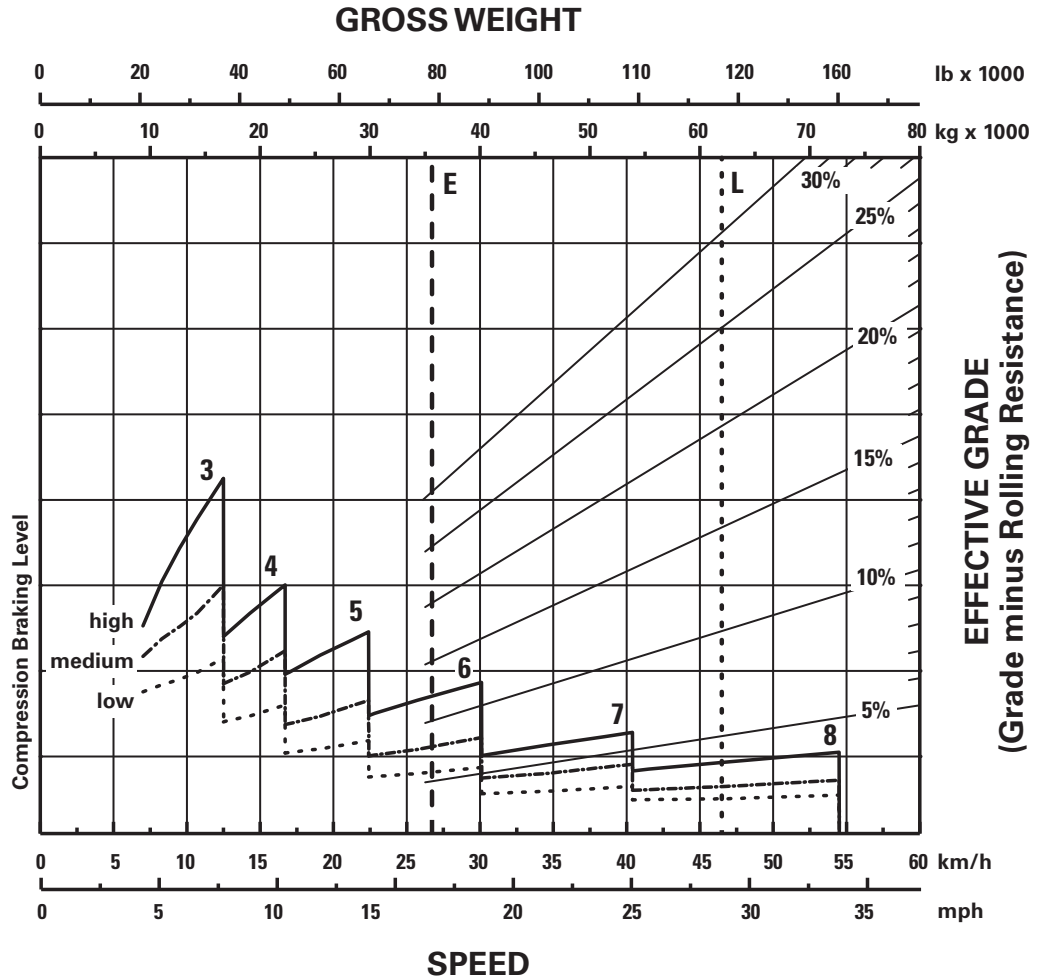

*at sea level

KEY

- 3 — 3rd Gear Direct Drive
- 4 — 4th Gear Direct Drive
- 5 — 5th Gear Direct Drive
- 6 — 6th Gear Direct Drive
- 7 — 7th Gear Direct Drive
- 8 — 8th Gear Direct Drive

KEY

- E — Empty 35 808 kg (78,943 lb)
- L — Loaded 61 935 kg (136,553 lb)

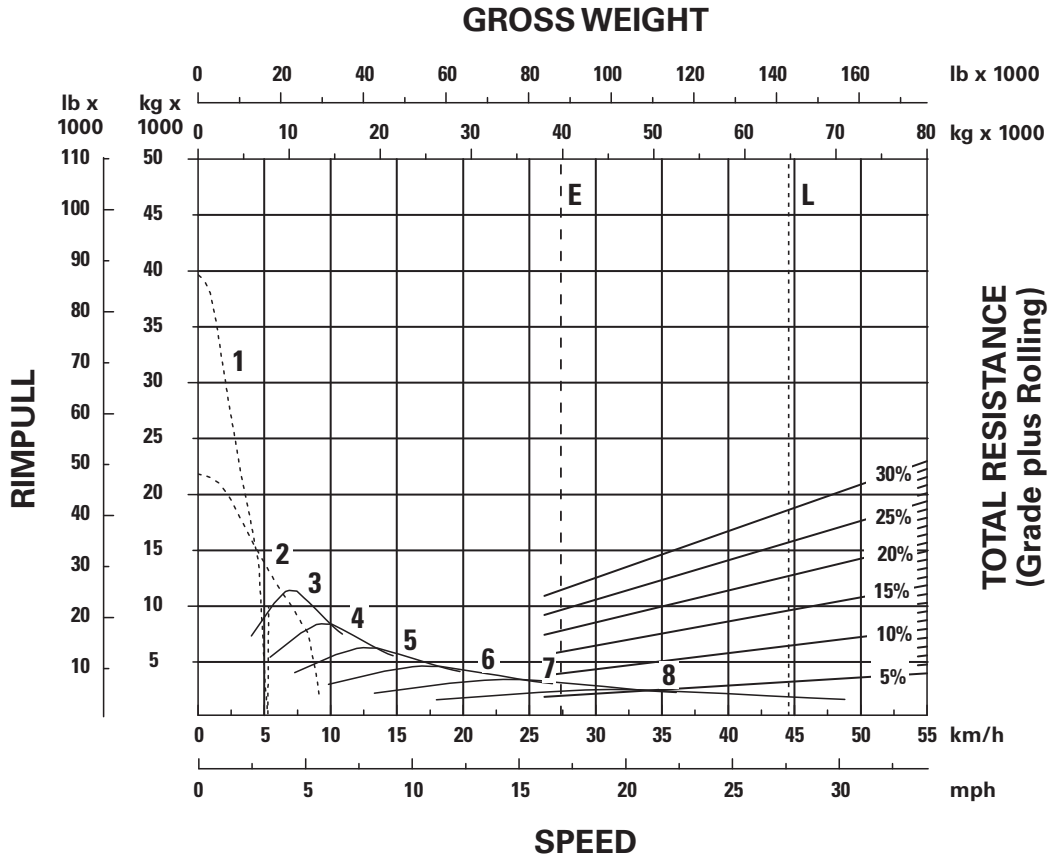

KEY

- 1 — 1st Gear Torque Converter Drive
- 2 — 2nd Gear Torque Converter Drive
- 3 — 3rd Gear Direct Drive
- 4 — 4th Gear Direct Drive
- 5 — 5th Gear Direct Drive
- 6 — 6th Gear Direct Drive
- 7 — 7th Gear Direct Drive
- 8 — 8th Gear Direct Drive

KEY

- E — Empty 39 866 kg ((87,809 lb)
- L — Loaded 64 904 kg (143,009 lb)

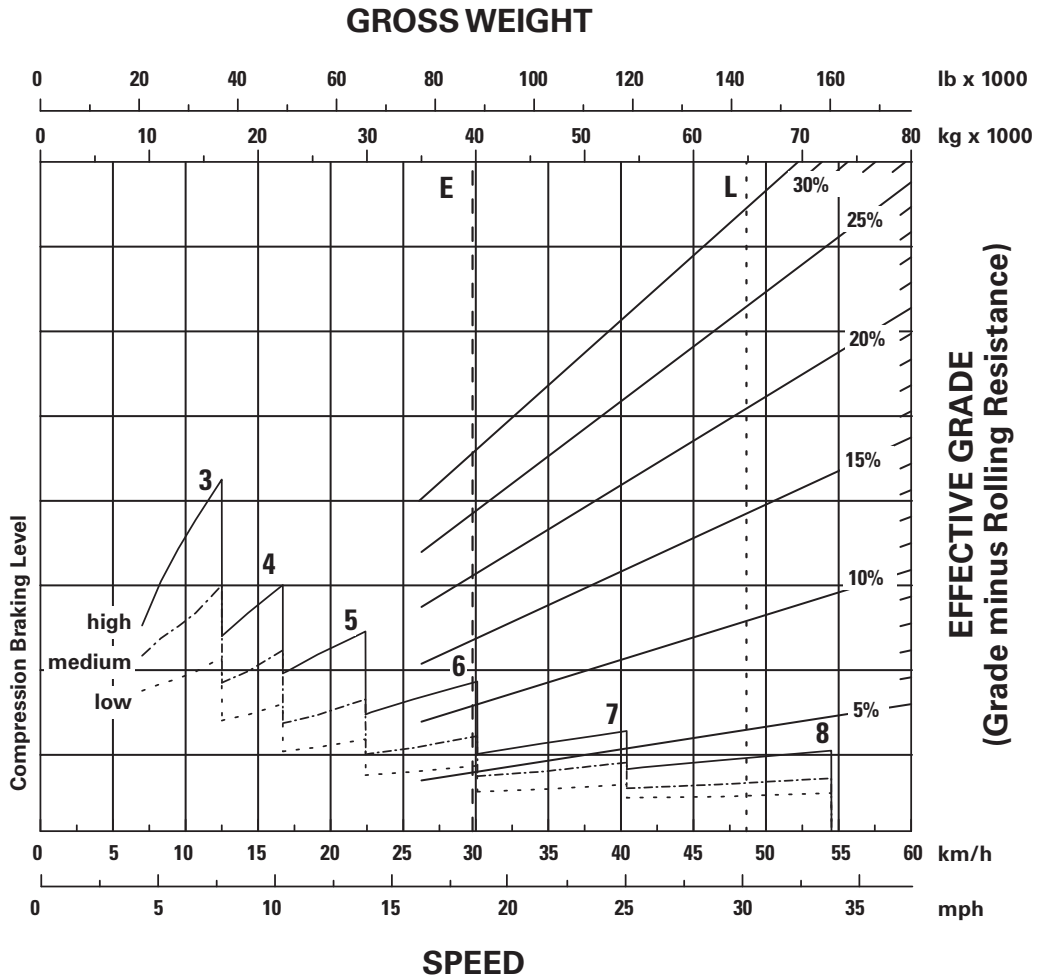

KEY

- 3 — 3rd Gear Direct Drive
- 4 — 4th Gear Direct Drive
- 5 — 5th Gear Direct Drive
- 6 — 6th Gear Direct Drive
- 7 — 7th Gear Direct Drive
- 8 — 8th Gear Direct Drive

KEY

- E — Empty 39 866 kg (87,809 lb)
- L — Loaded 64 904 kg (143,009 lb)

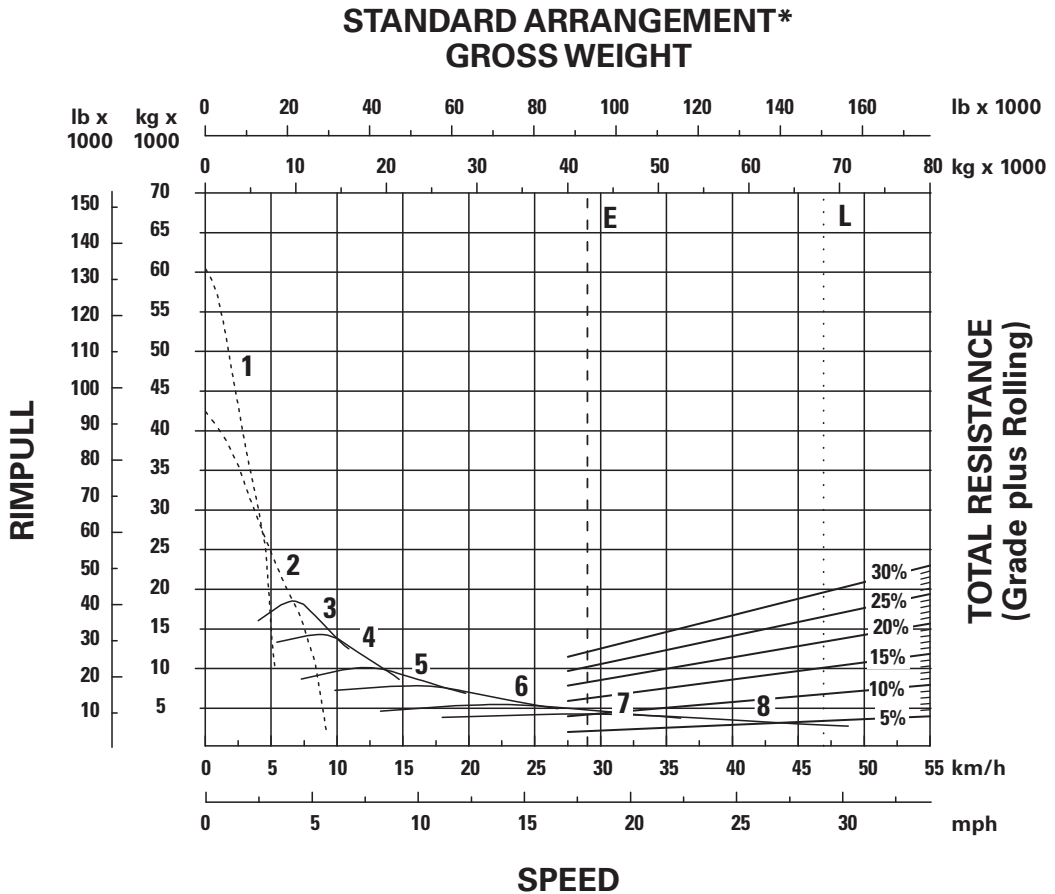

*at sea level

KEY

- 1 — 1st Gear Torque Converter Drive
- 2 — 2nd Gear Torque Converter Drive
- 3 — 3rd Gear Direct Drive
- 4 — 4th Gear Direct Drive
- 5 — 5th Gear Direct Drive
- 6 — 6th Gear Direct Drive
- 7 — 7th Gear Direct Drive
- 8 — 8th Gear Direct Drive

KEY

- E — Empty 42 158 kg (92,942 lb)
- L — Loaded 68 289 kg (150,552 lb)

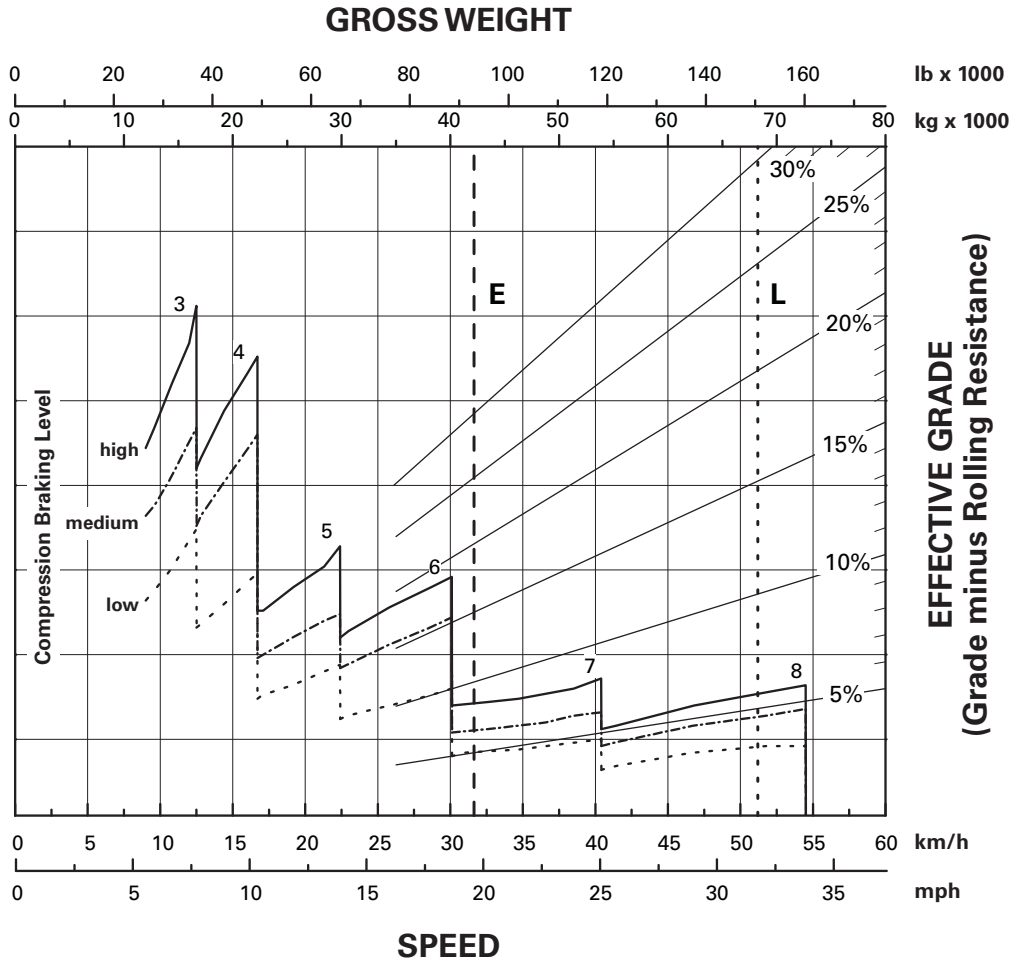

*at sea level

KEY

- 3 — 3rd Gear Direct Drive
- 4 — 4th Gear Direct Drive
- 5 — 5th Gear Direct Drive
- 6 — 6th Gear Direct Drive
- 7 — 7th Gear Direct Drive
- 8 — 8th Gear Direct Drive

KEY

- E — Empty 42 158 kg (92,942 lb)
- L — Loaded 68 289 kg (150,552 lb)

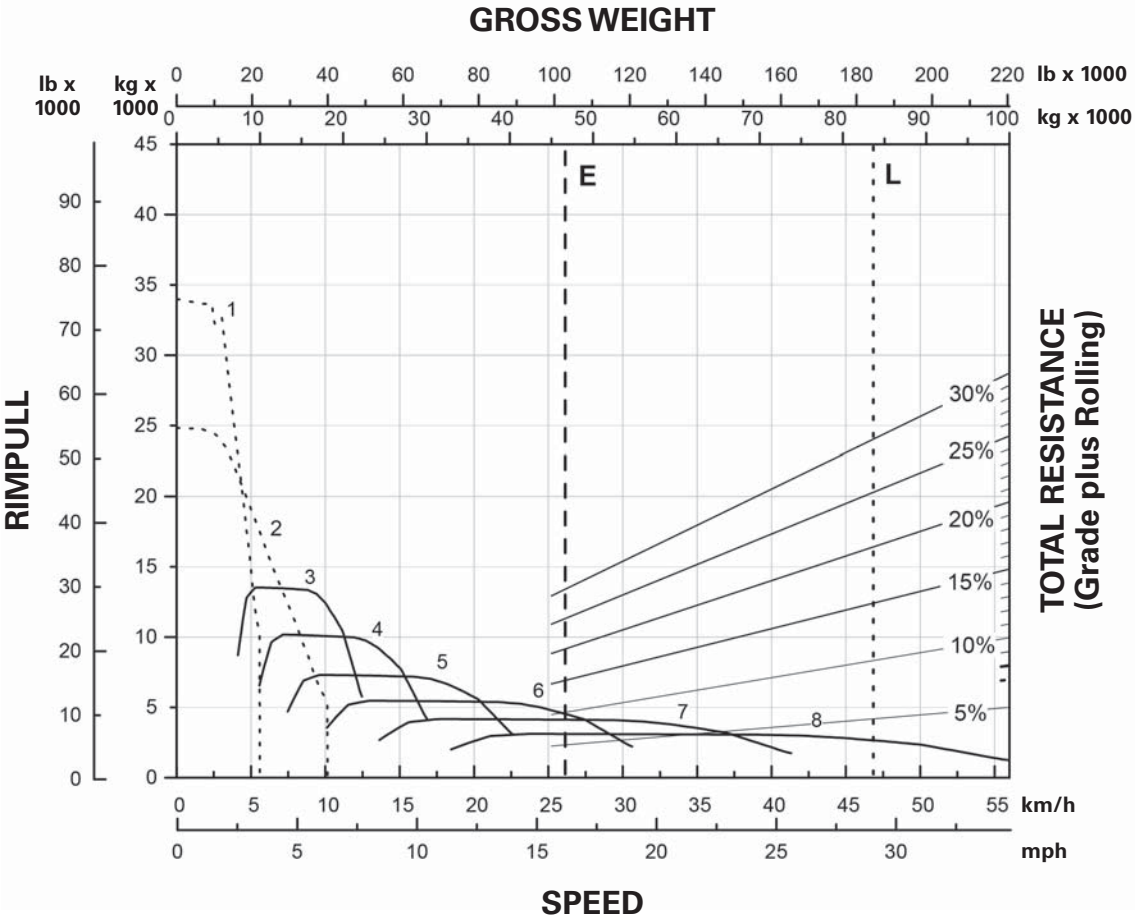

KEY

- 1 — 1st Gear Torque Converter Drive
- 2 — 2nd Gear Torque Converter Drive
- 3 — 3rd Gear Direct Drive
- 4 — 4th Gear Direct Drive
- 5 — 5th Gear Direct Drive
- 6 — 6th Gear Direct Drive
- 7 — 7th Gear Direct Drive
- 8 — 8th Gear Direct Drive

KEY

- E — Empty 46 607 kg (102,750 lb)
- L — Loaded 83 892 kg (184,950 lb)

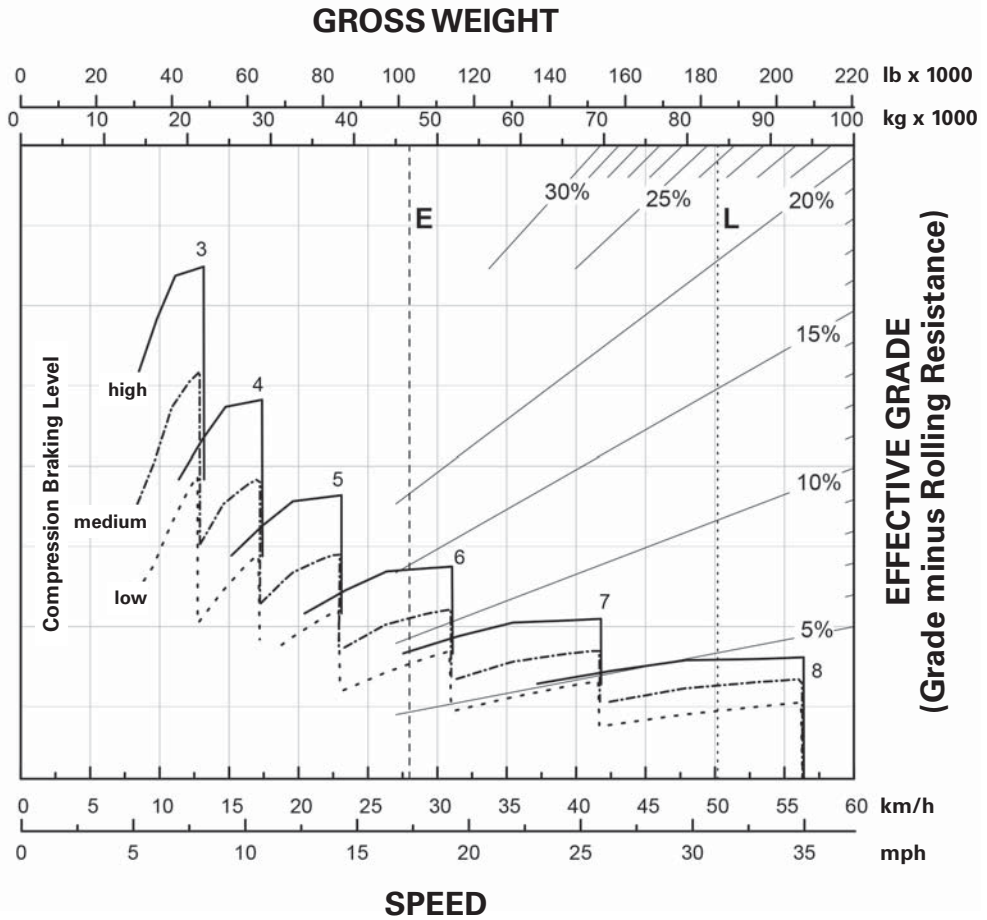

KEY

- 3 — 3rd Gear Direct Drive
- 4 — 4th Gear Direct Drive
- 5 — 5th Gear Direct Drive
- 6 — 6th Gear Direct Drive
- 7 — 7th Gear Direct Drive
- 8 — 8th Gear Direct Drive

KEY

- E — Empty 46 607 kg (102,750 lb)
- L — Loaded 83 892 kg (184,950 lb)

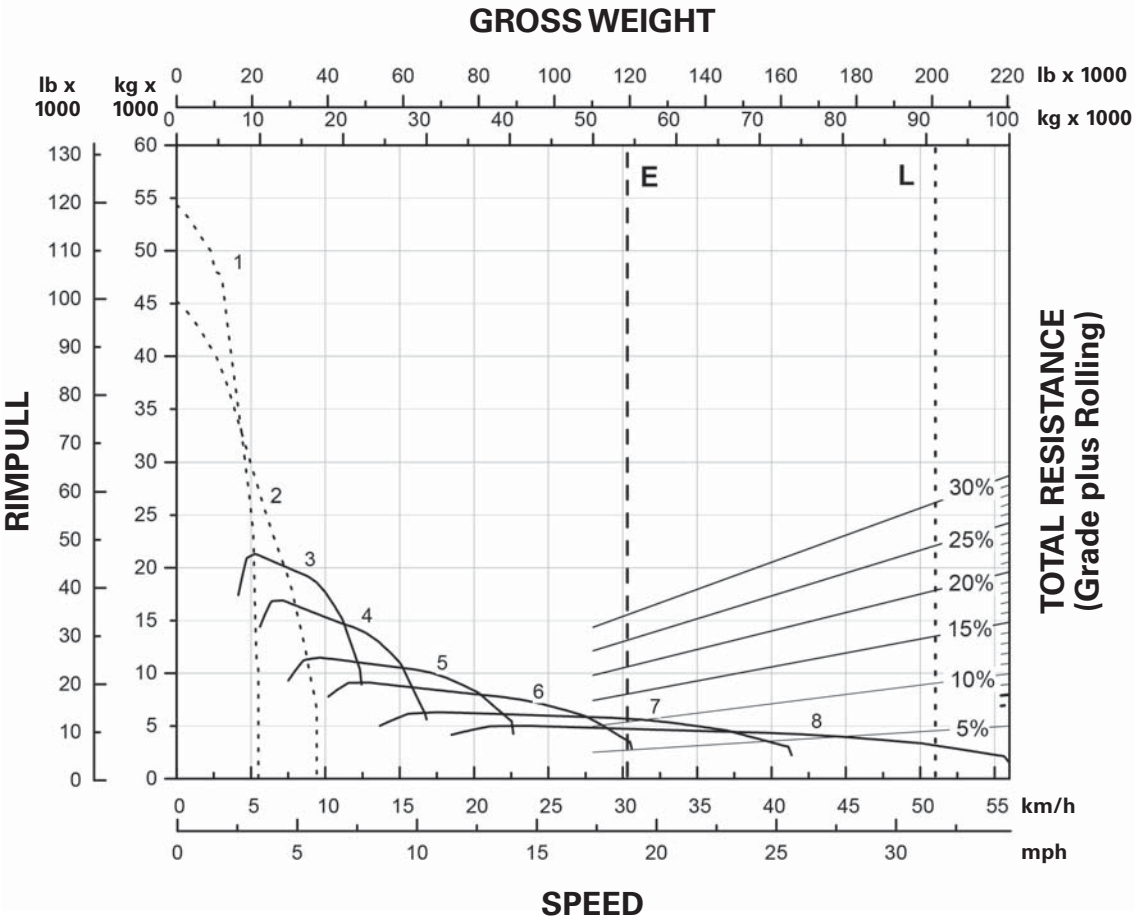

KEY

- 1 — 1st Gear Torque Converter Drive
- 2 — 2nd Gear Torque Converter Drive
- 3 — 3rd Gear Direct Drive
- 4 — 4th Gear Direct Drive
- 5 — 5th Gear Direct Drive
- 6 — 6th Gear Direct Drive
- 7 — 7th Gear Direct Drive
- 8 — 8th Gear Direct Drive

KEY

- E — Empty 54 005 kg (119,060 lb)
- L — Loaded 91 290 kg (201,260 lb)

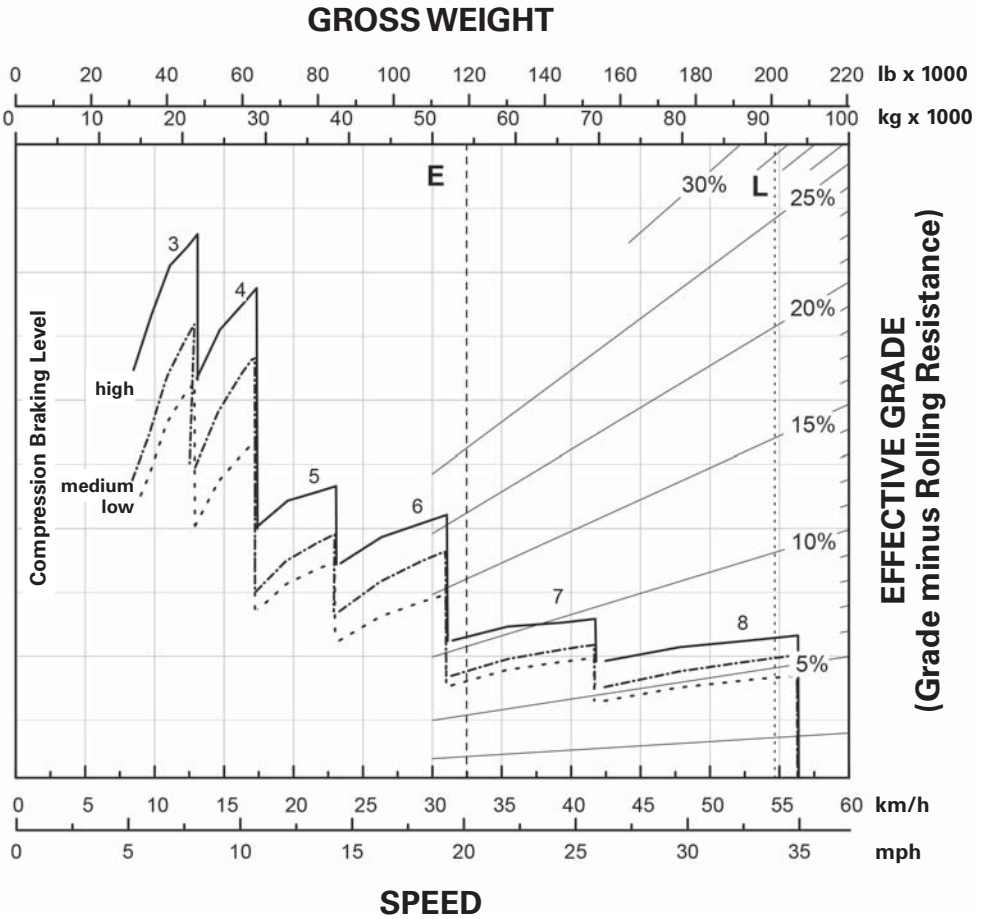

KEY

- 3 — 3rd Gear Direct Drive
- 4 — 4th Gear Direct Drive
- 5 — 5th Gear Direct Drive
- 6 — 6th Gear Direct Drive
- 7 — 7th Gear Direct Drive
- 8 — 8th Gear Direct Drive

KEY

- E — Empty 54 005 kg (119,060 lb)
- L — Loaded 91 290 kg (201,260 lb)

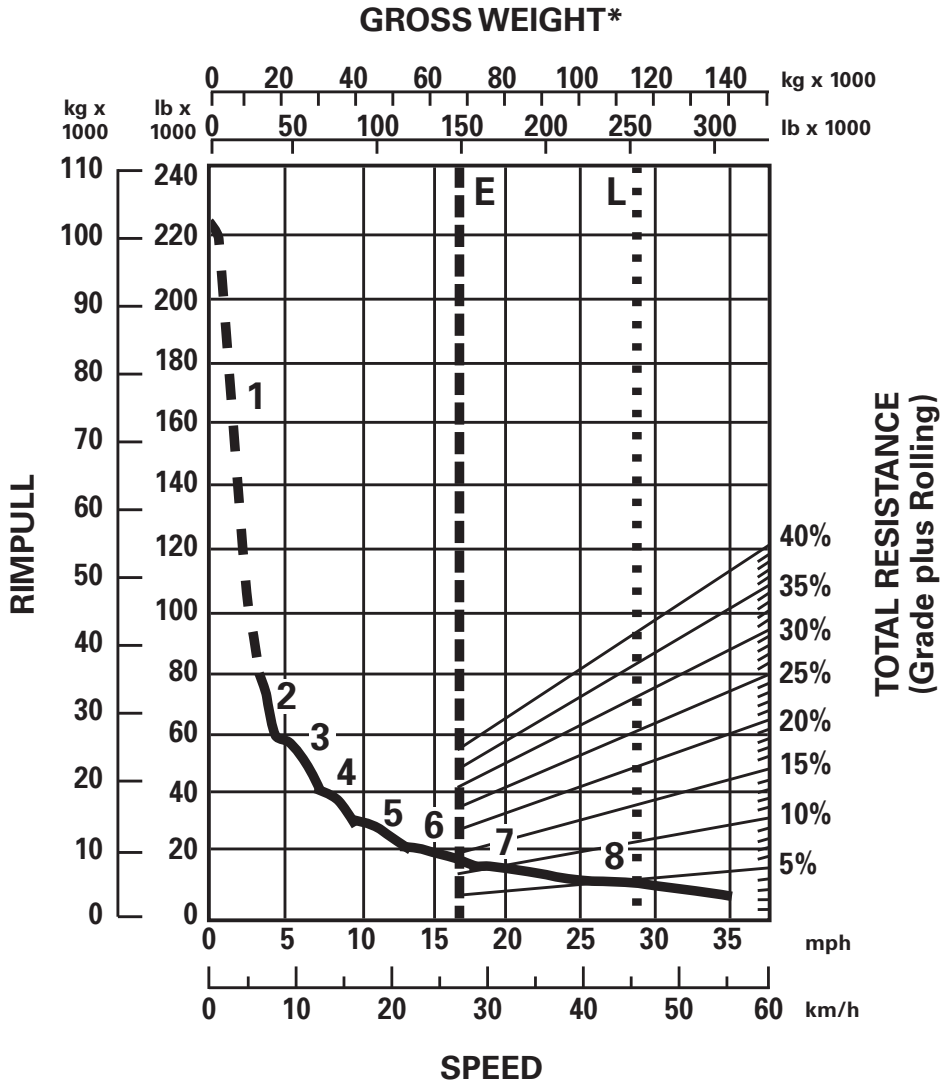

*at sea level

KEY

- 1 — 1st Gear Torque Converter Drive
- 2 — 2nd Gear Torque Converter Drive
- 3 — 3rd Gear Direct Drive
- 4 — 4th Gear Direct Drive
- 5 — 5th Gear Direct Drive
- 6 — 6th Gear Direct Drive
- 7 — 7th Gear Direct Drive
- 8 — 8th Gear Direct Drive

KEY

- E — Empty 72 804 kg (160,505 lb)
- L — Loaded 119 978 kg (264,505 lb)

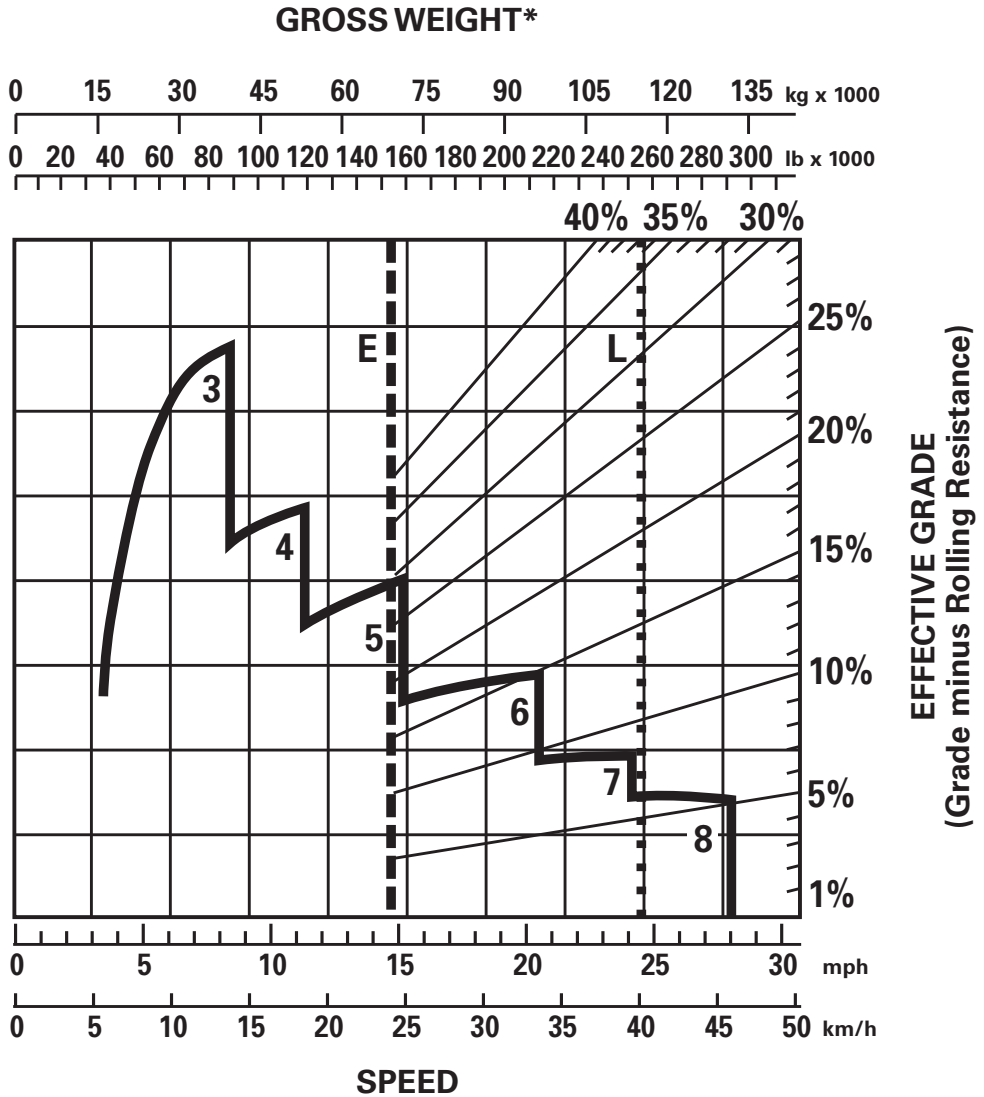

*at sea level

KEY

- 3 — 3rd Gear Direct Drive
- 4 — 4th Gear Direct Drive
- 5 — 5th Gear Direct Drive
- 6 — 6th Gear Direct Drive
- 7 — 7th Gear Direct Drive
- 8 — 8th Gear Direct Drive

KEY

- E — Empty 72 804 kg (160,505 lb)
- L — Loaded 119 978 kg (264,505 lb)

ESTIMATING OWNING & OPERATING COSTS

Owning & Operating (O&O) Baseline Cost Estimate Solutions

The O&O web site provides information related to O&O baseline cost estimate development for both commercial engine products and machines. Approved O&O baseline cost estimate ranges for machines, and links related to O&O baseline cost development are also available. **NOTE:** Access to the web sites indicated below is restricted to Caterpillar and Cat® dealer personnel.

For information about O&O costs, enter the appropriate link.

For Corporate Global Mining (CGM): <https://mining.cat.com>
Select "Support," "Equipment Management," "MARCs," "BUILDER Downloads."

For North American Commercial Division (NACD): <https://dealer.cat.com>
Select "Product Support," "Equipment Management Solutions,"
"Owning and Operating Cost Information."

CONTENTS

Estimating Form	25-2
Explanation of Form:	
Estimating Owning Costs	25-5
Typical Application Descriptions	25-5
① Delivered Price to the Customer	25-6
② Residual Value at Replacement	25-6
③ Value to be Recovered through Work	25-7
④ Interest	25-7
⑤ Insurance	25-7
⑥ Taxes	25-7
⑧ Fuel Consumption, Fuel Tables	25-8
⑨ Planned Maintenance Costs	25-41
⑩ Tires:	
Tire Life Estimator Curves	25-42
Goodyear Life Estimating System	25-45
⑩b Undercarriage	25-46
Basic Factors, "Z" Factors, Conditions and Multipliers	25-46
⑪ Repair Costs	25-48
⑫ Special Wear Items	25-50
⑮ Operator's Hourly Wage	25-50
O&O Cost Examples	
Example I: Track-Type Tractor	25-50
Example II: Wheel Loader	25-52
O&O Form with Example Figures	25-53

General

Machine users must balance productivity and costs to achieve optimum performance ... that is, achieve the desired production at the lowest possible cost. The approach most often used to measure machine performance is this simple equation:

$$\frac{\text{Lowest Possible Hourly Costs}}{\text{Highest Possible Hourly Productivity}} = \frac{\text{Top Machine Performance}}{\text{Performance}}$$

Most sections of this Handbook deal with the productivity of Cat machines. This section considers the cost aspect of performance.

Hourly Owning and Operating Costs for a given machine can vary widely because they are influenced by many factors: the type of work the machine does, the ownership period, local prices of fuel and labor, the repair and maintenance costs, shipping costs from the factory, interest rates, etc. No attempt is made in this handbook to provide precise hourly costs for each model. Users must be able to estimate with a reasonable degree of accuracy what a machine will cost per hour to own and operate in a given application and locality. Therefore, this section provides a suggested method of estimating hourly owning and operating costs. When this method is coupled with local conditions and dealer input, it will result in reasonable estimates.

The method suggested follows several basic principles:

- Repair and Planned Maintenance cost per hour are developed jointly by the customer and local Cat dealer.
- In the examples, labor is assumed @ \$60.00 per hour, fuel @ \$1.25 per gallon. For reliable estimates, these costs must always be obtained locally.
- Because of different standards of comparison, what may seem a high application to one machine owner may appear only medium to another.
- Unless otherwise specified, the word "hour" when used in this section means clock or operating hours, not Service Meter Units.

NOTE: An Excel O&O Estimating Form is available, in electronic spreadsheet format, to calculate an Hourly Owning & Operating Cost Estimate based on the procedure outlined in this section. The spreadsheet may be accessed via the website at <https://dealer.cat.com> – From the home page, select “Product Support,” “Equipment Management Solutions,” “Owning & Operating Costs.” Under the heading “Machine Technical Information,” select “O&O COST ESTIMATING Form.”

HOURLY OWNING AND OPERATING COST ESTIMATE

DATE _____

Estimate #1 Estimate #2

- A–Machine Designation _____
- B–Estimated Ownership Period (Years) _____
- C–Estimated Usage (Hours/Year) _____
- D–Ownership Usage (Total Hours)(B × C) _____

OWNING COSTS

1. a. Delivered Price (P), to the Customer (including attachments) _____
- b. Less Tire Replacement Cost if desired _____
- c. Delivered Price Less Tires. _____
2. Less Residual Value at Replacement (S) (____%) _____ (____%) _____
 (See subsection 2A on back)
3. a. Net Value to be recovered through work _____
 (line 1c less line 2)
- b. Cost Per Hour:
 Net Value (1) _____ (2) _____
 Total Hours
4. Interest Costs $\frac{P(N + 1) + S(N - 1)}{2N} \times \text{Simple Int. \% Rate}$
 N = No. Yrs. Hours/Year =
 (1) $\frac{+1}{+1} + \frac{-1}{-1} \times \text{____ \%}$ (2) $\frac{+1}{+1} + \frac{-1}{-1} \times \text{____ \%}$
 _____ Hours/Yr. = _____ Hours/Yr. = _____
5. Insurance $\frac{P(N + 1) + S(N - 1)}{2N} \times \text{Insurance \% Rate}$
 N = No. Yrs. Hours/Year =
 (1) $\frac{+1}{+1} + \frac{-1}{-1} \times \text{____ \%}$ (2) $\frac{+1}{+1} + \frac{-1}{-1} \times \text{____ \%}$
 _____ Hours/Yr. = _____ Hours/Yr. = _____
 (Optional method when Insurance cost per year is known)
 Ins. \$ _____ Per Yr. ÷ _____ Hours/Yr. =

Estimate #1

Estimate #2

6. Property Tax $\frac{P(N + 1) + S(N - 1)}{2N} \times \text{Tax Rate \%}$
 N = No. Yrs. _____ =
 Hours/Year

(1) $\frac{+1}{\text{Hours/Yr.}} + \frac{-1}{\text{Hours/Yr.}} \times \text{\%}$ (2) $\frac{+1}{\text{Hours/Yr.}} + \frac{-1}{\text{Hours/Yr.}} \times \text{\%}$
 _____ = _____ =

(Optional method when Property Tax cost per year is known)

Property Tax \$ _____ Per Yr. \div _____ Hours/Yr. =

7. TOTAL HOURLY OWNING COST
 (add lines 3b, 4, 5 and 6)

OPERATING COSTS

8. Fuel: Unit Price \times Consumption
 (1) _____ \times _____ =
 (2) _____ \times _____ =

9. Planned Maintenance (PM)-Lube Oils, Filters, Grease, Labor:
 (contact your local Cat dealer).

10. a. Tires: Replacement Cost \div Life in Hours
 $\frac{\text{Cost}}{\text{Life}}$ (1) _____ (2) _____

b. Undercarriage
 (Impact + Abrasiveness + Z Factor) \times Basic Factor
 (1) (_____ + _____ + _____) = _____ \times _____ =
 (2) (_____ + _____ + _____) = $\frac{\text{_____}}{\text{(Total)}} \times \frac{\text{_____}}{\text{(Factor)}} =$

11. Repair Cost (Per Hour)
 (contact your local Cat dealer).

12. Special Wear Items: Cost \div Life
 (See subsection 12A on back)

13. TOTAL OPERATING COSTS
 (add lines 8, 9, 10a (or 10b), 11 and 12).

14. MACHINE OWNING PLUS OPERATING
 (add lines 7 and 13)

15. OPERATOR'S HOURLY WAGE (include fringes)

16. TOTAL OWNING AND OPERATING COST

SUBSECTION 2A: Residual Value at Replacement

Gross Selling Price	(est. #1) (___%)	_____	(est. #2) (___%)	_____
Less: a. Commission		_____		_____
b. Make-ready costs		_____		_____
c. Inflation during ownership period*		_____		_____
Net Residual Value		_____	(___%)	_____ (___%) of original
(Enter on line 2)				delivered price

*When used equipment auction prices are used to estimate residual value, the effect of inflation during the ownership period should be removed to show in constant value what part of the asset must be recovered through work.

**SUBSECTION 12A: Special Items
(cutting edges, ground engaging tools, bucket teeth, etc.)**

(1)	Cost	Life	Cost/Hour	(2)
1.	_____ ÷ _____	=	_____	1. _____ ÷ _____ = _____
2.	_____ ÷ _____	=	_____	2. _____ ÷ _____ = _____
3.	_____ ÷ _____	=	_____	3. _____ ÷ _____ = _____
4.	_____ ÷ _____	=	_____	4. _____ ÷ _____ = _____
5.	_____ ÷ _____	=	_____	5. _____ ÷ _____ = _____
6.	_____ ÷ _____	=	_____	6. _____ ÷ _____ = _____
	Total	(1)	_____	(2) _____

(Enter total on line 12)

1-7

ESTIMATING OWNING COSTS*(Line Items 1 through 7)*

To protect their equipment investment and be able to replace it, the machine owner must recover over the ownership period an amount equal to the loss in resale value plus the other costs of owning the equipment including interest, insurance and taxes.

The machine owner, for accounting purposes, estimates resale value loss in advance, and recovers his original equipment investment by establishing depreciation schedules according to the various uses of the equipment. Proper financial and tax assistance is highly recommended when establishing depreciation schedules.

Considering today's economic conditions worldwide and the trend toward larger, more expensive equipment, many users choose to keep these units on the job well after they have been fully depreciated for tax purposes. On the other hand, tax incentives in many areas may favor trading a machine well before that occurs.

The ownership period in years, the hours per year, and the total number of hours on a machine, are significant factors in determining O&O costs. Additionally, since the ownership period and machine hours can vary widely for different customers for a given model, it is not practical to calculate O&O costs using an assumed ownership period. The customer must provide that information for each situation.

These same factors will be used to develop the Repair costs and Planned Maintenance costs by your local Cat dealer.

The machine depreciation method suggested in this handbook is not based on or related to any tax considerations, but rather is a simple straight line write-off based solely on the number of years and hours the owner expects to use during the ownership period.

Accordingly, it is imperative that careful consideration be given the selection of depreciation periods, and that for owning and operating cost calculations they be based on actual ownership periods and hours on the machine rather than tax write-off life.

Typical Application Descriptions

The following tables show typical descriptions for work performed by each product family for three different application levels. It is only a guide and can be used along with the fuel and tire charts to help determine fuel and tire cost factors. Additionally, many times the ownership period and the number of hours per year a machine is used, is related to application.

25

1

DELIVERED PRICE TO CUSTOMER

(Line Item 1a, b and c)

Delivered price should include all costs of putting a machine on the user's job including transportation and any applicable sales taxes.

On rubber tired machines, tires are considered a wear item and covered as an operating expense. Accordingly, some users may wish to deduct tire costs from the delivered price particularly for larger machines.

2

RESIDUAL VALUE AT REPLACEMENT

(Line Item 2 and Subsection 2A)

Any piece of earthmoving machinery will have some residual value at trade-in. While many owners prefer to depreciate their equipment to zero value, others recognize the residual resale or trade-in value. This is at the estimator's option, but as in the discussion of depreciation, today's higher equipment costs almost dictate that resale value be considered in determining the net depreciable investment. And if machines are traded early for tax incentive purposes, resale value becomes even more significant.

For many owners, potential resale or trade-in value is a key factor in their purchasing decisions, since this is a means of reducing the investment they must recover through depreciation charges. The high resale value of Caterpillar built machines can reduce hourly depreciation charges, lower total hourly owning costs and improve the owner's competitive position.

When resale or trade-in value is used in estimating hourly owning and operating costs, local conditions must be considered, as used equipment values vary widely around the world. However, in any given used equipment business, factors which have greatest influence on resale or trade-in value are: age of machine (years), the number of hours on the machine at the time of sale or trade, the type of jobs and operating conditions in which it worked, and the physical condition of the machine. Your local Cat dealer is your best source for determining current used equipment values.

Subsection 2A can be used to calculate the estimated residual value. If recent auction prices for used machines are used as a guide, then the value (or percentage) should be adjusted downward to remove the effect of inflation. Governmental indices on construction equipment costs or Dealer price records can be used to calculate the amount of inflation for the appropriate useful life. Another way to estimate residual value is comparing the current used machine value to the current new machine price provided major product changes haven't occurred.

③ Value to be Recovered Through Work

④ Interest

⑤ Insurance

⑥ Taxes

Owning & Operating Costs

3

VALUE TO BE RECOVERED THROUGH WORK

(Line Item 3a and b)

The delivered price (P) less the estimated residual value (S) results in the value to be recovered through work, divided by the total usage hours, gives the hourly cost to protect the asset's value.

4

INTEREST

(Line Item 4)

Many owners charge interest as part of hourly owning and operating costs, others consider it as general overhead in their overall operation. When charged to specific machines, interest is usually based on the owner's average annual investment in the unit.

Interest is considered to be the cost of using capital. The interest on capital used to purchase a machine must be considered, whether the machine is purchased outright or financed.

If the machine will be used for N years (where N is the number of years of use), calculate the average annual investment during the use period and apply the interest rate and expected annual usage:

$$\frac{\left[\frac{P(N + 1) + S(N - 1)}{2N} \right] \times \text{Simple Int. \% Rate}}{\text{Hours/Year}}$$

5-6

INSURANCE AND TAXES

(Line Items 5 and 6)

Insurance cost and property taxes can be calculated in one of two ways. If the specific annual cost is known, this figure should be divided by the estimated usage (hours/years) and used. However, when the specific interest and tax costs for each machine are not known, the following formulas can be applied:

$$\frac{\text{Insurance}}{N = \text{No. Years}}$$

$$\frac{\left[\frac{P(N + 1) + S(N - 1)}{2N} \right] \times \text{Insurance \% Rate}}{\text{Hours/Year}}$$

$$\frac{\text{Property Tax}}{N = \text{No. Years}}$$

$$\frac{\left[\frac{P(N + 1) + S(N - 1)}{2N} \right] \times \text{Tax Rate \%}}{\text{Hours/Year}}$$

8-13

ESTIMATING OPERATING COSTS*(Line Items 8 through 13)*

8

FUEL CONSUMPTION*(Line Item 8)*

Actual fuel consumption should be measured in the field. However, if no opportunity exists to do this, consumption can be estimated when the machine application is known.

Application determines engine load factor and engine fuel consumption. Engine load factor refers to the instantaneous loading of the engine relative to its maximum capability. An engine continuously producing full rated horsepower is operating at a load factor of 100%. Earthmoving machines may reach a 100% load factor intermittently, but seldom operate at this level for extended periods of time. Periods spent at idle, dozer and pusher travel in reverse, haul units traveling empty, close maneuvering at part throttle and operating downhill are examples of conditions which reduce load factor.

The following tables provide hourly fuel consumption estimates at various load factors. Engine load factors are to be used as a general guide and will vary by model and application. Since machine uses vary, application guides are also provided to aid in estimating load factor.

To estimate hourly fuel cost, select the load factor based on application and find hourly consumption. Then:

$$\text{Hourly consumption} \times \text{Local Unit Price of Fuel} = \text{Hourly Fuel Cost}$$

When using these tables, keep in mind the many variables which can affect fuel consumption. Two operators of different temperament or attitude operating identical machines side by side in the same material can have as much as 10-12% difference in their consumption rates. Actual results may vary from the ranges shown because they are created to cover a wide spectrum of operating conditions. Your Cat dealer representative can help select the most reasonable estimate for your specific situation; we suggest you call on him.

Keep in mind also that a fuel consumption study measured over a short period of operation will give higher fuel consumption than shown here because: (1) the study will be at 100% productivity, without breaks or idle time, and (2) the operators will know they're being measured and therefore may not use their normal operating techniques. On the other hand, these tables allow for "normal" inefficiencies in the working cycle and will more closely relate to "normal" day to day operation.

FUEL CONSUMPTION TABLES AND LOAD FACTOR GUIDES

TRACK-TYPE TRACTORS

Model	Low		Medium		High	
	liter	U.S. gal	liter	U.S. gal	liter	U.S. gal
D3K2 ³	7.6	2.0	8.7	2.3	15.5	4.1
D4K2 ³	8.3	2.2	9.5	2.5	15.9	4.2
D5K2 ³	8.7	2.3	9.9	2.6	16.7	4.4
D3K2 ¹	6.8	1.8	7.6	2.0	15.2	4.0
D4K2 ¹	7.6	2.0	8.3	2.2	15.5	4.1
D5K2 ¹	8.0	2.1	8.7	2.3	15.9	4.2
D5R	12.1-15.1	3.2-4.0	15.1-20.0	4.0-5.3	20.0-26.4	5.3-6.9
D6K2 ³	—	—	12.0	3.2	—	—
D6K2 ¹	—	—	11.3	3.0	—	—
D6N ³	12.1-15.1	3.2-4.0	15.1-20.0	4.0-5.3	20.0-26.4	5.3-6.9
D6N ²	9.9-13.3	2.6-3.5	13.3-17.5	3.5-4.6	17.5-24.9	4.6-6.6
D6R (130 kW/175 hp)	13.2-18.9	3.5-5.0	18.9-24.6	5.0-6.5	24.6-30.3	6.5-8.0
D6R (145 kW/195 hp)	14.8-21.2	3.9-5.6	21.2-27.3	5.6-7.2	27.3-33.7	7.2-8.9
D6T (138 kW/185 hp)	15.5-22.3	4.1-5.9	22.3-28.8	5.9-7.6	28.8-35.6	7.6-9.4
D6T ¹	15.0-21.3	4.0-5.6	21.3-27.7	5.6-7.3	27.7-34.0	7.3-9.0
D7E ¹	13.6-19.3	3.6-5.1	19.3-25.2	5.1-6.7	25.2-31.8	6.7-8.4
D7R	17.8-24.4	4.7-6.5	24.4-31.0	6.5-8.2	31.0-37.6	8.2-9.9
D8R	22.5-32.0	6.0-8.5	32.0-41.5	8.5-11.0	41.5-51.0	11.0-13.5
D8T ³	23.5-33.7	6.2-8.9	33.7-43.5	8.9-11.5	43.9-53.7	11.6-14.2
D8T ¹	23.7-34.3	6.3-9.1	34.3-44.2	9.1-11.7	44.1-54.2	11.7-14.3
D9T ³	30.3-43.1	8.0-11.4	43.1-56.4	11.4-14.9	56.4-69.3	14.9-18.3
D9T ⁴	28.2-40.1	7.4-10.6	40.1-52.5	10.6-13.9	52.5-64.4	13.9-17.0
D9T ¹	31.2-44.4	8.2-11.7	44.4-58.1	11.7-15.3	58.1-71.4	15.3-18.9
D10T2 ⁶	39.5-56.3	10.4-14.9	56.3-73.3	14.9-19.4	73.3-90.2	19.4-23.9
D10T2 ⁵	43.0-61.3	11.4-16.3	61.3-79.8	16.3-21.1	79.8-98.2	21.1-26.0
D11T ⁶	59.6-85.2	15.8-22.5	85.2-110.7	22.5-29.3	110.7-136.3	29.3-36.0
D11T ⁵	60.3-86.1	15.9-22.8	86.1-112.0	22.8-29.6	112.0-137.8	29.6-36.4

¹ Meets U.S. EPA Tier 4 Final/EU Stage IV/Japan 2014 (Tier 4 Final) emission standards — Calculations include DEF.

² Meets Tier 4 Interim/Stage II B/Japan 2011 (Tier 4 Interim) equivalent emission standards.

³ Meets Tier 3/Stage III A/Japan 2006 (Tier 3) equivalent emission standards.

⁴ Meets Tier 2/Stage II/Japan 2001 (Tier 2) equivalent emission standards.

⁵ Meets Tier 4 Final emission standards.

⁶ Meets Tier 2 equivalent emission standards.

Typical Application Description

(relative to work application)

Low Pulling scrapers, most agricultural drawbar, stockpile, coal pile and finish grade applications. No impact. Intermittent full throttle operation.

Medium Production dozing in clays, sands, gravels. Push loading scrapers, borrow pit ripping, most land clearing applications. Medium impact conditions. Production landfill work.

High Heavy rock ripping. Push loading and dozing in hard rock. Working on rock surfaces. Continuous high impact conditions.

Load Factor Guide

(average engine load factor based on application description for each range)

Low 35%-50%

Medium 50%-65%

High 65%-80%

Product Link™ Information — Product link measured over hundreds of Track-Type Tractors shows that more than 90% of the machines experience an average fuel consumption equal to or lower than those shown in the Medium Application profile.

- Pipelayers
- Motor Graders

PIPELAYERS

Model	Low		Medium		High	
	liter	U.S. gal	liter	U.S. gal	liter	U.S. gal
PL61	5.7-11.7	1.5-3.0	9.7-15.1	2.5-4.0	13.2-18.9	3.5-5.0
PL83	11.8-16.9	3.1-4.5	16.9-21.8	4.5-5.8	21.8-26.8	5.8-7.1
PL87	15.3-21.9	4.0-5.8	21.9-28.3	5.8-7.5	28.3-34.9	7.5-9.2
572R Series 2	8.5-12.3	2.2-3.3	12.3-15.7	3.3-4.2	15.7-19.5	4.2-5.2

Typical Application Description

(relative to work application)

Low Little or no use in mud, water or on rock. Use on level, regular surfaces.

Medium Typical pipelayer use in operating conditions ranging from very good to severe.

High Continuous use in deep mud or water or on rock surfaces.

Load Factor Guide

(average engine load factor based on application description for each range)

Low 35%-50%

Medium 50%-65%

High 65%-80%

MOTOR GRADERS

Model	Low		Medium		High	
	liter	U.S. gal	liter	U.S. gal	liter	U.S. gal
K SERIES						
120K ¹	7.6-9.6	2.0-2.5	9.6-15.9	2.5-4.2	15.9-22.3	4.2-5.9
12K ¹	8.9-11.1	2.3-2.9	11.1-18.5	2.9-4.9	18.5-25.8	4.9-6.8
140K ¹	9.3-11.6	2.5-3.1	11.6-19.4	3.1-5.1	19.4-27.2	5.1-7.2
160K ¹	10.0-12.5	2.6-3.3	12.5-20.8	3.3-5.5	20.8-29.1	5.5-7.7
120K2 ²	7.9-9.9	2.1-2.6	9.9-16.4	2.6-4.3	16.4-23.0	4.3-6.1
140K2 ²	9.8-12.2	2.6-3.2	12.2-20.3	3.2-5.4	20.3-28.5	5.4-7.5

¹ Meets Tier 2/Stage II/Japan 2001 (Tier 2) equivalent emission standards.

² Meets Tier 3/Stage IIIA/Japan 2006 (Tier 3) equivalent emission standards.

NOTE: The Motor Grader fuel rates are taken directly from our customer machines registered on Product Link worldwide. Fuel consumption varies depending upon geographical region, emission level, weight, application, fuel quality and other factors. Long term, most machines (approximately 90%) will see fuel consumption equal to or lower than the Medium Range. These values are subject to change. Consult your local dealer for ways to more accurately estimate hourly fuel consumption for specific applications.

MOTOR GRADERS

Model	Low		Medium		High	
	liter	U.S. gal	liter	U.S. gal	liter	U.S. gal
M SERIES						
120M ³	6.3-7.9	1.7-2.1	7.9-13.1	2.1-3.5	13.1-18.4	3.5-4.9
120M AWD ³	7.8-9.8	2.1-2.6	9.8-16.3	2.6-4.3	16.3-22.8	4.3-6.0
12M ³	6.9-8.7	1.8-2.3	8.7-14.4	2.3-3.8	14.4-20.2	3.8-5.3
12M (B92) ³	9.3-11.6	2.4-3.1	11.6-19.3	3.1-5.1	19.3-27.0	5.1-7.1
140M ³	9.7-12.1	2.6-3.2	12.1-20.1	3.2-5.3	20.1-28.2	5.3-7.4
140M AWD ³	11.9-14.9	3.1-3.9	14.9-24.8	3.9-6.6	24.8-34.7	6.6-9.2
160M ³	10.2-12.7	2.7-3.4	12.7-21.2	3.4-5.6	21.2-29.7	5.6-7.8
160M AWD ³	11.9-14.9	3.2-3.9	14.9-24.8	3.9-6.6	24.8-34.8	6.6-9.2
120M2 ⁴	7.2-9.0	1.9-2.4	9.0-15.0	2.4-4.0	15.0-21.0	4.0-5.5
120M2 AWD ⁴	8.2-10.2	2.2-2.7	10.2-17.1	2.7-4.5	17.1-23.9	4.5-6.3
12M2 ⁴	8.6-10.8	2.3-2.9	10.8-18.0	2.9-4.8	18.0-25.2	4.8-6.7
12M2 AWD ⁴	9.9-12.4	2.6-3.3	12.4-20.7	3.3-5.5	20.7-29.0	5.5-7.7
140M2 ⁴	9.3-11.6	2.5-3.1	11.6-19.4	3.1-5.1	19.4-27.2	5.1-7.2
140M2 AWD ⁴	10.7-13.4	2.8-3.5	13.4-22.3	3.5-5.9	22.3-31.2	5.9-8.2
160M2 ⁴	10.4-13.0	2.7-3.4	13.0-21.7	3.4-5.7	21.7-30.3	5.7-8.0
160M2 AWD ⁴	11.1-13.9	2.9-3.7	13.9-23.2	3.7-6.1	23.2-32.5	6.1-8.6
12M3 ⁵	8.4-10.5	2.2-2.8	10.5-17.5	2.8-4.6	17.5-24.5	4.6-6.5
12M3 AWD ⁵	9.7-12.1	2.6-3.2	12.1-20.1	3.2-5.3	20.1-28.2	5.3-7.4
140M3 ⁵	9.1-11.4	2.4-3.0	11.4-18.9	3.0-5.0	18.9-26.5	5.0-7.0
140M3 AWD ⁵	10.4-13.0	2.7-3.4	13.0-21.6	3.4-5.7	21.6-30.2	5.7-8.0
160M3 ⁵	10.1-12.6	2.7-3.3	12.6-21.1	3.3-5.6	21.1-29.5	5.6-7.8
160M3 AWD ⁵	10.8-13.5	2.9-3.6	13.5-22.5	3.6-5.9	22.5-31.5	5.9-8.3
14M ³	10.6-13.2	2.8-3.5	13.2-22.0	3.5-5.8	22.0-30.9	5.8-8.2
16M ³	13.3-16.6	3.5-4.4	16.6-27.7	4.4-7.3	27.7-38.7	7.3-10.2
16M3 ^{5,6}	To Be Determined		To Be Determined		To Be Determined	
16M3 ^{2,6}	To Be Determined		To Be Determined		To Be Determined	
16M3 ^{3,6}	To Be Determined		To Be Determined		To Be Determined	
18M3 ^{5,6}	To Be Determined		To Be Determined		To Be Determined	
18M3 ^{2,6}	To Be Determined		To Be Determined		To Be Determined	
18M3 ^{3,6}	To Be Determined		To Be Determined		To Be Determined	
24M (B9K) ¹	25.0-31.2	6.6-8.3	31.2-52.0	8.3-13.8	52.0-72.9	13.8-19.3
24M (B9K) ³	27.3-34.1	7.2-9.0	34.1-56.8	9.0-15.0	56.8-79.5	15.0-21.0
24M (B93) ²	26.1-32.6	6.9-8.6	32.6-54.4	8.6-14.4	54.4-76.2	14.4-20.1
24M (B93) ³	26.7-33.4	7.1-8.8	33.4-55.6	8.8-14.7	55.6-77.8	14.7-20.6

¹ Unregulated.

² Meets Tier 2/Stage II/Japan 2001 (Tier 2) equivalent emission standards.

³ Meets Tier 3/Stage IIIA/Japan 2006 (Tier 3) equivalent emission standards.

⁴ Meets Tier 4 Interim/Stage IIIB/Japan 2011 (Tier 4 Interim) equivalent emission standards.

⁵ Meets Tier 4 Final/Stage IV/Japan 2014 (Tier 4 Final) emission standards. Machine requires the use of Diesel Exhaust Fluid (DEF) with consumption rate of approximately 2-3% of diesel fuel.

⁶ Fuel consumption to be determined as population increases. Consult your local dealer for ways to more accurately estimate hourly fuel consumption for specific applications.

NOTE: The Motor Grader fuel rates are taken directly from our customer machines registered on Product Link worldwide. Fuel consumption varies depending upon geographical region, emission level, weight, application, fuel quality and other factors. Long term, most machines (approximately 90%) will see fuel consumption equal to or lower than the Medium Range. These values are subject to change. Consult your local dealer for ways to more accurately estimate hourly fuel consumption for specific applications.

Motor Graders

Typical Application Description

(relative to work application)

- Low Light road maintenance. Finish grading. Plant and road mix work. Extended idle.
- Medium Haul road maintenance. Average road maintenance, road mix work, scarifying. Road construction, ditching, loose fill spreading. Land forming, land leveling and elevating grader use. Light to medium snow removal. Lower speed travel on slight grades.
- High Heavy maintenance of hard packed roads with embedded rock. Heavy fill spreading, base material spreading and ditching. Ripping/scarifying of asphalt or concrete. Continuous high load factor. High impact. Heavy snow plowing. High speed travel on grades.

Load Factor Guide

(average engine load factor based on Product Status Report for description for each range)

- Low 20%-30%
- Medium 30%-50%
- High 50%-80%

⑧ Hourly Fuel Consumption Tables
 ● Skid Steer Loaders, Multi Terrain Loaders
 and Compact Track Loaders

Owning & Operating Costs

SKID STEER LOADERS, MULTI TERRAIN LOADERS AND COMPACT TRACK LOADERS

Model	Low		Medium		High	
	liter	U.S. gal	liter	U.S. gal	liter	U.S. gal
226D ¹	5.0-7.2	1.3-1.9	7.2-9.3	1.9-2.5	9.3-11.4	2.5-3.0
232D ¹	5.0-7.2	1.3-1.9	7.2-9.3	1.9-2.5	9.3-11.4	2.5-3.0
236D ¹	5.6-7.5	1.4-2.0	7.5-9.8	2.0-2.6	9.8-12.0	2.6-3.2
239D ¹	5.0-7.2	1.3-1.9	7.2-9.3	1.9-2.5	9.3-11.4	2.5-3.0
242D ¹	5.6-7.5	1.4-2.0	7.5-9.8	2.0-2.6	9.8-12.0	2.6-3.2
246D ¹	5.6-7.5	1.4-2.0	7.5-9.8	2.0-2.6	9.8-12.0	2.6-3.2
249D ¹	5.0-7.2	1.3-1.9	7.2-9.3	1.9-2.5	9.3-11.4	2.5-3.0
257D ¹	5.6-7.5	1.4-2.0	7.5-9.8	2.0-2.6	9.8-12.0	2.6-3.2
259D ¹	5.6-7.5	1.4-2.0	7.5-9.8	2.0-2.6	9.8-12.0	2.6-3.2
262D ¹	5.6-7.5	1.4-2.0	7.5-9.8	2.0-2.6	9.8-12.0	2.6-3.2
277D ¹	5.6-7.5	1.4-2.0	7.5-9.8	2.0-2.6	9.8-12.0	2.6-3.2
279D ¹	5.6-7.5	1.4-2.0	7.5-9.8	2.0-2.6	9.8-12.0	2.6-3.2
287D ¹	5.6-7.5	1.4-2.0	7.5-9.8	2.0-2.6	9.8-12.0	2.6-3.2
289D ¹	5.6-7.5	1.4-2.0	7.5-9.8	2.0-2.6	9.8-12.0	2.6-3.2
272D2 ²	7.0-10.1	1.9-2.7	10.1-13.1	2.7-3.5	13.1-16.1	3.5-4.3
272D2 XHP ²	7.6-10.9	2.0-2.9	10.9-14.2	2.9-3.7	14.2-17.5	3.7-4.6
297D2 ²	7.0-10.1	1.9-2.7	10.1-13.1	2.7-3.5	13.1-16.1	3.5-4.3
297D2 XHP ²	7.6-10.9	2.0-2.9	10.9-14.2	2.9-3.7	14.2-17.5	3.7-4.6
299D2 ²	7.0-10.1	1.9-2.7	10.1-13.1	2.7-3.5	13.1-16.1	3.5-4.3
299D2 XHP ²	7.6-10.9	2.0-2.9	10.9-14.2	2.9-3.7	14.2-17.5	3.7-4.6
216B3 ³	3.98-5.69	1.05-1.50	5.69-7.40	1.50-1.95	7.40-9.11	1.95-2.41
226B3 ³	5.89-8.42	1.56-2.22	8.42-10.94	2.22-2.89	10.94-13.47	2.89-3.56
232D ³	5.2-7.4	1.4-2.0	7.4-9.6	2.0-2.5	9.6-11.8	2.5-3.1
236D ³	5.7-8.1	1.5-2.2	8.1-10.6	2.2-2.8	10.6-13.0	2.8-3.4
239D ³	5.2-7.4	1.4-2.0	7.4-9.6	2.0-2.5	9.6-11.8	2.5-3.1
242D ³	5.7-8.1	1.5-2.2	8.1-10.6	2.2-2.8	10.6-13.0	2.8-3.4
246D ³	5.7-8.1	1.5-2.2	8.1-10.6	2.2-2.8	10.6-13.0	2.8-3.4
249D ³	5.2-7.4	1.4-2.0	7.4-9.6	2.0-2.5	9.6-11.8	2.5-3.1
257D ³	5.7-8.1	1.5-2.2	8.1-10.6	2.2-2.8	10.6-13.0	2.8-3.4
259D ³	5.7-8.1	1.5-2.2	8.1-10.6	2.2-2.8	10.6-13.0	2.8-3.4
262D ³	5.7-8.1	1.5-2.2	8.1-10.6	2.2-2.8	10.6-13.0	2.8-3.4
277D ³	5.7-8.1	1.5-2.2	8.1-10.6	2.2-2.8	10.6-13.0	2.8-3.4
279D ³	5.7-8.1	1.5-2.2	8.1-10.6	2.2-2.8	10.6-13.0	2.8-3.4
287D ³	5.7-8.1	1.5-2.2	8.1-10.6	2.2-2.8	10.6-13.0	2.8-3.4
289D ³	5.7-8.1	1.5-2.2	8.1-10.6	2.2-2.8	10.6-13.0	2.8-3.4

¹ Meets Tier 4 Final, Stage IIIB, Japan 2011 (Tier 4 Interim) emission standards.

² Meets Tier 4 Final, Stage IV, Japan 2014 (Tier 4 Final) emission standards.

³ Meets Tier 4 Interim, Stage IIIA, Japan 2006 (Tier 3) equivalent emission standards OR Tier 2, Stage II, Japan 2001 (Tier 2) equivalent emission standards.

Owning & Operating Costs

- ⑧ Hourly Fuel Consumption Tables
- Skid Steer Loaders, Multi Terrain Loaders and Compact Track Loaders
 - Underground Mining — Hard Rock Articulated Trucks

Skid Steer Loaders, Multi Terrain Loaders and Compact Track Loaders

Typical Application Description

(relative to work application)

- Low** Light utility, construction, nursery and landscaping applications. Load and carry of free flowing, low density materials on firm, smooth surfaces for short distances with minimal grades. Light snow removal.
- Medium** Industrial and construction job site applications. Loading from bank or load and carry of low to medium density materials on normal surfaces with low to medium rolling resistance and slight adverse grades. Occasional use of various attachments under normal loading conditions.
- High** Continuous industrial, construction and batch plant applications. Loading from tight banks or load and carry of high density materials on rough or very soft surfaces with high rolling resistance and adverse grades. Maximum use of high flow attachments under high loading conditions.

Load Factor Guide

(average engine load factor based on application description for each range)

- Low 35%-50%
- Medium 50%-65%
- High 65%-80%

UNDERGROUND MINING — Hard Rock Articulated Trucks

Model	Low		Medium		High	
	liter	U.S. gal	liter	U.S. gal	liter	U.S. gal
AD30	27.0-38.0	7.1-10.0	38.0-45.0	10.0-11.9	45.0-56.0	11.9-14.8
AD45B	35.0-45.0	9.2-11.9	45.0-55.0	11.9-14.5	55.0-65.0	14.5-17.2
AD55 Flat Haul	35.0-42.0	9.2-11.1	42.0-57.0	11.1-15.0	57.0-70.0	15.0-18.5
AD60	45.0-55.0	11.9-14.5	55.0-65.0	14.5-17.2	65.0-80.0	17.2-21.1

Typical Application Description

(relative to work application)

- Low** Continuous operation at <80% of maximum recommended gross weight. Short to medium haul distances: 300-1000 m (**990-3300 feet**). Well maintained, level haul roads. Considerable amount of idling. Very few tray impacts. Low load factor.
- Medium** Intermittent operation at less than maximum recommended gross weight. Medium to longer haul distances: 1000-5000 m (**3300-16,000 feet**). Varying haul road conditions with some adverse grades. Occasional tray impacts. Medium load factor.
- High** Continuous operation at maximum recommended gross weight. Long haul distances: >5000 m (**>16,000 feet**). Poor haul road conditions with adverse/steep grades. Frequent tray impacts. High load factor.

Load Factor Guide

(average engine load factor based on application description for each range)

- Low 20%-40%
- Medium 40%-60%
- High 60%-80%

⑧ Hourly Fuel Consumption Tables
 ● Underground Mining —
 Hard Rock Load-Haul-Dumps (LHD's)

Owning & Operating Costs

UNDERGROUND MINING — Hard Rock Load-Haul-Dumps (LHD's)

Model	Low		Medium		High	
	liter	U.S. gal	liter	U.S. gal	liter	U.S. gal
R1300G	11.3-15.1	3.0-4.0	15.1-18.9	4.0-5.0	18.9-22.7	5.0-6.0
R1600H	15.1-22.7	4.0-6.0	22.7-28.3	6.0-7.5	28.3-39.7	7.5-10.5
R1700G	22.7-26.4	6.0-7.0	26.4-34.0	7.0-9.0	34.0-45.4	9.0-12.0
R2900G	30.2-37.8	8.0-10.0	37.8-45.4	10.0-12.0	45.4-56.7	12.0-15.0
R3000H	33.0-40.0	8.7-10.5	40.0-47.0	10.5-12.4	47.0-59.0	12.4-15.6

Typical Application Description

(relative to work application)

- Low Dig and carry operation from stockpiles to ground level transfer station. Low density, free flowing ore and waste. Excellent draw point floor surfaces. Short haul distances: 25-100 m (**80-330 feet**). Level roads with good surface conditions. Low load factor.
- Medium Intermittent development/production loading into trucks/transfer station. Good digging with well shot, low to medium density ore and waste. Average draw point floor surfaces. Medium haul distances: 100-200 m (**330-660 feet**). Poor road surfaces with slightly adverse grades. Medium load factor.
- High Continuous production loading of trucks at or near maximum load height. Difficult digging. Loading haul trucks. Rough draw point surfaces. Long haul distances: 200-300 m (**660-990 feet**). Poor haul roads with adverse grades. High load factor.

Load Factor Guide

(average engine load factor based on application description for each range)

- Low 20%-40%
- Medium 40%-60%
- High 60%-80%

EXCAVATORS

Model	Low		Medium		High	
	liter	U.S. gal	liter	U.S. gal	liter	U.S. gal
MHE D SERIES						
300.9D	0.9-1.4	0.24-0.35	1.4-1.8	0.35-0.47	1.8-2.3	0.47-0.59
301.7D	0.9-1.4	0.24-0.35	1.4-1.8	0.35-0.47	1.8-2.3	0.47-0.59
301.7D CR	0.9-1.4	0.24-0.35	1.4-1.8	0.35-0.47	1.8-2.3	0.47-0.59
302.4D	1.2-1.8	0.31-0.47	1.8-2.4	0.47-0.62	2.4-3.0	0.62-0.78
302.7D CR	1.2-1.8	0.31-0.47	1.8-2.4	0.47-0.62	2.4-3.0	0.62-0.78
MHE E SERIES						
303E CR	1.1-2.3	0.3-0.6	2.3-3.4	0.6-0.9	3.4-4.6	0.9-1.2
303.5E CR	1.5-2.9	0.4-0.8	2.9-4.4	0.8-1.2	4.4-5.8	1.2-1.5
303.5E2 CR	1.11-2.22	0.29-0.60	2.22-3.32	0.60-0.90	3.32-4.43	0.90-1.17
304E2 CR	1.8-3.7	0.5-1.0	3.7-5.5	1.0-1.5	5.5-7.3	1.5-1.9
305E2 CR	1.8-3.7	0.5-1.0	3.7-5.5	1.0-1.5	5.5-7.3	1.5-1.9
305.5E2 CR	2.0-4.0	0.5-1.1	4.0-6.0	1.1-1.6	6.0-8.0	1.6-2.1
308E2	2.7-5.4	0.7-1.4	5.4-8.0	1.4-2.1	8.0-10.7	2.1-2.8
306E, 307E	2.3-4.6	0.6-1.2	4.6-6.9	1.2-1.8	6.9-9.2	1.8-2.4
305.5E	2.0-4.0	0.5-1.1	4.0-6.0	1.1-1.6	6.0-8.0	1.6-2.1
308E	2.9-5.7	0.8-1.5	5.7-8.6	1.5-2.3	8.6-11.5	2.3-3.0
HEX D SERIES						
311D RR* (STD C4.2 ACERT)	3.5-6.5	0.9-1.7	6.5-9.5	1.7-2.5	9.5-12.8	2.5-3.4
312D* (STD C4.2 ACERT)	4.0-7.5	1.1-2.0	7.5-11.5	2.0-3.0	11.5-15.2	3.0-4.0
312D* (ECO C4.2 ACERT)	3.6-6.8	1.0-1.8	6.8-10.4	1.8-2.7	10.4-13.7	2.7-3.6
314D CR* (STD C4.2 ACERT)	4.0-7.5	1.1-2.0	7.5-11.5	2.0-3.0	11.5-15.2	3.0-4.0
315D* (STD C4.2 ACERT)	5.0-9.5	1.3-2.5	9.5-14.5	2.5-3.8	14.5-19.2	3.8-5.1
315D* (ECO C4.2 ACERT)	4.5-8.6	1.2-2.3	8.6-13.1	2.3-3.5	13.1-17.3	3.5-4.6
319D* (STD C4.2 ACERT)	5.5-10.5	1.5-2.8	10.5-15.5	2.8-4.1	15.5-21.0	4.1-5.5
320D2** (STD Panther)	5.3-13.3	1.4-3.5	13.3-18.6	3.5-4.9	18.6-26.5	4.9-7.0
323D2** (HHP Unity)	5.4-13.5	1.4-3.6	13.5-18.9	3.6-5.0	18.9-27.0	5.0-7.1
336D* (ECO C9 ACERT)	9.5-19.1	2.5-5.0	19.1-28.6	5.0-7.6	28.6-37.8	7.6-10.0
336D* (STD C9 ACERT)	10.2-20.5	2.7-5.4	20.5-30.7	5.4-8.1	30.7-40.5	8.1-10.7
336D* (HHP C9 ACERT)	11.5-23.0	3.0-6.1	23.0-34.5	6.1-9.1	34.5-45.5	9.1-12.0
336D** (ECO C9 ACERT)	9.1-17.8	2.4-4.7	17.8-27.0	4.7-7.1	27.0-36.1	7.1-9.5
336D** (STD C9 ACERT)	9.8-19.1	2.6-5.1	19.1-28.9	5.1-7.6	28.9-38.7	7.6-10.2
336D** (HHP C9 ACERT)	11.0-21.5	2.9-5.7	21.5-32.5	5.7-8.6	32.5-43.5	8.6-11.5
345D* (C13 ACERT)	15.5-30.5	4.1-8.1	30.5-45.6	8.1-12.0	45.6-61.0	12.0-16.1
345D** (C13 ACERT)	14.5-29.0	3.8-7.7	29.0-43.3	7.7-11.4	43.3-58.0	11.4-15.3
374D*^ (C15 ACERT)	28.0-46.0	7.4-12.2	46.0-55.0	12.2-14.5	55.0-68.0	14.5-18.0
374D*^^ (C15 ACERT)	26.6-43.7	7.0-11.5	43.7-52.3	11.5-13.8	52.3-64.6	13.8-17.1
390D*^ (C18 ACERT)	31.0-52.0	8.2-13.7	52.0-66.5	13.7-17.6	66.5-77.0	17.6-20.3
390D*^^ (C18 ACERT)	29.5-49.4	7.8-13.0	49.4-63.2	13.0-16.7	63.2-73.2	16.7-19.3

*Meets Tier 3/Stage IIIA/Japan 2006 (Tier 3) equivalent emission standards.

**Meets Tier 2/Stage II/Japan 2001 (Tier 2) equivalent emission standards.

^374D and 390D hourly fuel rates are taken directly from customer machines registered on Product Link worldwide. Data from the top and bottom 5% of these customer machines has been excluded from the tables because it varies widely and therefore is not considered representative of what the remaining 90% of customers experience. Hourly fuel consumption for the 90% of machines in the tables also varies depending upon geographical region, load factor variation between units, etc. Cat machines are often used in more demanding applications which can account for differences between competitive models used in lighter duty applications. Consult your local Cat dealer for ways to more accurately estimate hourly fuel consumption for specific applications.

If the application of these machines is to be used for scrap handling, the LOW hourly fuel consumption rate would typically apply.

NOTE: Fuel consumption rates for 320D through 390D include machine at idle per load factor definition.

EXCAVATORS

Model	Low		Medium		High	
	liter	U.S. gal	liter	U.S. gal	liter	U.S. gal
HEX D2 SERIES						
312D2/313D2*** (STD 3054C)	3.6-7.1	1.0-1.9	7.1-10.7	1.9-2.8	10.7-14.2	2.8-3.7
312D2/313D2*** (ECO 3054C)	3.1-6.2	0.8-1.6	6.2-9.3	1.6-2.5	9.3-12.4	2.5-3.3
312D2 GC*** (STD 3054C)	3.1-6.2	0.8-1.6	6.2-9.3	1.6-2.5	9.3-12.4	2.5-3.3
318D2*** (STD 3054CA)	4.5-8.9	1.2-2.3	8.9-13.4	2.3-3.5	13.4-17.8	3.5-4.7
318D2*** (ECO 3054CA)	3.9-7.8	1.0-2.1	7.8-11.8	2.1-3.1	11.8-15.7	3.1-4.1
320D2 GC*** (ECO Panther)	4.8-9.5	1.3-2.5	9.5-14.3	2.5-3.8	14.3-19.0	3.8-5.0
326D2** (HHP C7.1 ACERT)	6.8-13.7	1.8-3.6	13.7-20.5	3.6-5.4	20.5-27.4	5.4-7.2
326D2** (ECO C7.1 ACERT)	5.1-10.2	1.3-2.7	10.2-15.4	2.7-4.1	15.4-20.5	4.1-5.4
326D2*** (HHP C7.1 ACERT)	6.7-13.5	1.8-3.6	13.5-20.2	3.6-5.3	20.2-27.0	5.3-7.1
326D2*** (ECO C7.1 ACERT)	5.2-10.4	1.4-2.7	10.4-15.5	2.7-4.1	15.5-20.7	4.1-5.5
330D2** (HHP C7.1 ACERT)	7.6-15.3	2.0-4.0	15.3-22.9	4.0-6.0	22.9-30.6	6.0-8.1
330D2** (ECO C7.1 ACERT)	5.7-11.4	1.5-3.0	11.4-17.2	3.0-4.5	17.2-22.3	4.5-5.9
330D2*** (HHP C7.1 ACERT)	7.2-14.4	1.9-3.8	14.4-21.6	3.8-5.7	21.6-28.8	5.7-7.6
330D2*** (ECO C7.1 ACERT)	5.4-10.8	1.4-2.9	10.8-16.3	2.9-4.3	16.3-21.7	4.3-5.7
336D2***/340D2**^ (C9 ACERT)	15.0-20.3	4.0-5.3	20.3-23.5	5.3-6.2	23.5-27.1	6.2-7.2
336D2 GC**^ (C9 ACERT)	13.5-18.2	3.6-4.8	18.2-21.1	4.8-5.6	21.1-24.4	5.6-6.5
349D2** (C13 ACERT)	14.8-29.6	3.9-7.8	29.6-44.4	7.8-11.7	44.4-59.2	11.7-15.6
349D2*** (C13 ACERT)	13.9-27.8	3.7-7.3	27.8-41.7	7.3-11.0	41.7-55.6	11.0-14.7
HEX E SERIES						
312E* (HHP C4.4)	3.6-7.1	0.9-1.9	7.1-10.7	1.9-2.8	10.7-14.2	2.8-3.8
312E* (ECO C4.4)	3.2-6.3	0.8-1.7	6.3-9.5	1.7-2.5	9.5-12.6	2.5-3.3
314E* (HHP C4.4)	3.1-6.2	0.8-1.6	6.2-9.3	1.6-2.5	9.3-12.4	2.5-3.3
314E* (ECO C4.4)	2.9-5.7	0.8-1.5	5.7-8.6	1.5-2.3	8.6-11.5	2.3-3.0
314E L* (HHP C4.4)	3.4-6.8	0.9-1.8	6.8-10.2	1.8-2.7	10.2-13.7	2.7-3.6
314E L* (ECO C4.4)	2.7-5.4	0.7-1.4	5.4-8.1	1.4-2.1	8.1-10.8	2.1-2.8
316E* (HHP C4.4)	4.5-9.1	1.2-2.4	9.1-13.6	2.4-3.6	13.6-18.2	3.6-4.8
316E* (ECO C4.4)	3.9-7.8	1.0-2.1	7.8-11.7	2.1-3.1	11.7-15.7	3.1-4.1
318E* (HHP C4.4)	4.5-9.1	1.2-2.4	9.1-13.6	2.4-3.6	13.6-18.2	3.6-4.8
318E* (ECO C4.4)	3.9-7.8	1.0-2.1	7.8-11.7	2.1-3.1	11.7-15.7	3.1-4.1
320E* (HHP C6.6 ACERT)	6.1-12.1	1.6-3.2	12.1-18.2	3.2-4.8	18.2-24.2	4.8-6.4
320E* (SHP C6.6 ACERT)	5.6-11.2	1.5-3.0	11.2-16.8	3.0-4.4	16.8-22.4	4.4-5.9
324E* (C7.1 ACERT)	7.0-14.5	1.8-3.8	14.5-21.5	3.8-5.7	21.5-29.0	5.7-7.7
329E* (C7.1 ACERT)	8.5-17.0	2.2-4.5	17.0-25.5	4.5-6.7	25.5-34.5	6.7-9.1
336E**^ (C9.3 ACERT)	13.5-22.0	3.6-5.8	22.0-29.0	5.8-7.7	29.0-36.0	7.7-9.5
349E* (C13 ACERT)	15.0-30.5	4.0-8.1	30.5-45.5	8.1-12.0	45.5-60.5	12.0-16.0

*Meets Tier 4 Interim/Stage IIIB/Japan 2011 (Tier 4 Interim) equivalent emission standards.

**Meets Tier 3/Stage IIIA/Japan 2006 (Tier 3) equivalent emission standards.

***Meets Tier 2/Stage II/Japan 2001 (Tier 2) equivalent emission standards.

^336D2/340D2, 336D2 GC and 336E hourly fuel rates are taken directly from customer machines registered on Product Link worldwide. Data from the top and bottom 5% of these customer machines has been excluded from the tables because it varies widely and therefore is not considered representative of what the remaining 90% of customers experience. Hourly fuel consumption for the 90% of machines in the tables also varies depending upon geographical region, load factor variation between units, etc. Cat machines are often used in more demanding applications which can account for differences between competitive models used in lighter duty applications. Consult your local Cat dealer for ways to more accurately estimate hourly fuel consumption for specific applications.

EXCAVATORS

Model	Low		Medium		High	
	liter	U.S. gal	liter	U.S. gal	liter	U.S. gal
HYBRID HEX E SERIES						
336E H***^ (C9.3 ACERT)	11.0-17.0	2.9-4.5	17.0-23.5	4.5-6.2	23.5-28.5	6.2-7.5
HYBRID HEX F SERIES						
336F XE**^ (C9.3 ACERT)	9.8-14.3	2.6-3.8	14.3-19.4	3.8-5.1	19.4-23.8	5.1-6.3
HEX F SERIES						
311F* (STD C3.4)	2.7-5.3	0.7-1.4	5.3-8.0	1.4-2.1	8.0-10.6	2.1-2.8
311F* (ECO C3.4)	2.4-4.8	0.6-1.3	4.8-7.2	1.3-1.9	7.2-9.6	1.9-2.5
312F GC/313F L GC (STD C3.4)	3.1-6.2	0.8-1.6	6.2-9.3	1.6-2.5	9.3-12.4	2.5-3.3
312F/313F L* (STD C4.4)	3.4-6.7	0.9-1.8	6.7-10.0	1.8-2.6	10.0-13.3	2.6-3.5
312F/313F L* (ECO C4.4)	2.7-5.4	0.7-1.4	5.4-8.1	1.4-2.2	8.1-10.8	2.2-2.9
316F L/318F L* (STD C4.4)	4.2-8.3	1.1-2.2	8.3-12.4	2.2-3.3	12.4-16.5	3.3-4.4
316F L/318F L* (ECO C4.4)	3.6-7.2	1.0-1.9	7.2-10.8	1.9-2.9	10.8-14.4	2.9-3.8
320F* (STD C4.4 ACERT)	5.4-10.9	1.4-2.9	10.9-16.3	2.9-4.3	16.3-21.8	4.3-5.7
320F* (ECO C4.4 ACERT)	4.5-8.9	1.2-2.4	8.9-13.4	2.4-3.5	13.4-17.8	3.5-4.7
323F* (HHP C7.1 ACERT)	5.4-10.8	1.4-2.9	10.8-16.2	2.9-4.3	16.2-21.6	4.3-5.7
323F* (STD C7.1 ACERT)	5.1-10.1	1.3-2.7	10.1-15.2	2.7-4.0	15.2-20.2	4.0-5.3
323F* (ECO C7.1 ACERT)	4.3-8.6	1.1-2.3	8.6-12.9	2.3-3.4	12.9-17.2	3.4-4.5
325F L CR* (HHP C4.4 ACERT)	5.9-11.8	1.6-3.1	11.8-17.7	3.1-4.7	17.7-23.6	4.7-6.2
325F L CR* (STD C4.4 ACERT)	5.6-11.2	1.5-3.0	11.2-16.7	3.0-4.4	16.7-22.3	4.4-5.9
325F L CR* (ECO C4.4 ACERT)	4.6-9.2	1.2-2.4	9.2-13.9	2.4-3.7	13.9-18.5	3.7-4.9
326F* (HHP C7.1 ACERT)	6.5-13.0	1.7-3.4	13.0-19.5	3.4-5.1	19.5-26.0	5.1-6.9
326F* (STD C7.1 ACERT)	6.0-12.0	1.6-3.2	12.0-18.0	3.2-4.8	18.0-24.0	4.8-6.3
326F* (ECO C7.1 ACERT)	4.9-9.7	1.3-2.6	9.7-14.6	2.6-3.9	14.6-19.4	3.9-5.1
329F* (HHP C7.1 ACERT)	8.0-16.0	2.1-4.2	16.0-24.1	4.2-6.4	24.1-32.1	6.4-8.5
329F* (STD C7.1 ACERT)	7.8-15.5	2.1-4.1	15.5-23.3	4.1-6.2	23.3-31.0	6.2-8.2
329F* (ECO C7.1 ACERT)	6.4-12.7	1.7-3.4	12.7-19.1	3.4-5.0	19.1-25.4	5.0-6.7
335F L CR* (HHP C7.1 ACERT)	7.8-15.6	2.1-4.1	15.6-23.4	4.1-6.2	23.4-31.2	6.2-8.2
335F L CR* (STD C7.1 ACERT)	7.0-14.1	1.8-3.7	14.1-21.1	3.7-5.6	21.1-28.2	5.6-7.4
335F L CR* (ECO C7.1 ACERT)	5.9-11.2	1.6-3.0	11.2-17.8	3.0-4.7	17.8-23.8	4.7-6.3
336F**^ (C9.3 ACERT)	12.0-18.5	3.2-4.9	18.5-24.0	4.9-6.3	24.0-30.0	6.3-7.9
349F* (C13 ACERT)	14.7-29.5	3.9-7.8	29.5-44.2	7.8-11.7	44.2-59.0	11.7-15.6
374F**^ (C15 ACERT)	19.0-32.0	5.0-8.5	32.0-42.0	8.5-11.1	42.0-49.0	11.1-12.9
374F***^ (C15 ACERT)	20.1-33.8	5.3-8.9	33.8-44.3	8.9-11.7	44.3-51.7	11.7-13.7
374F****^ (C15 ACERT)	19.2-32.4	5.1-8.6	32.4-42.5	8.6-11.2	42.5-49.5	11.2-13.1
390F**^ (C18 ACERT)	22.0-39.0	5.8-10.3	39.0-50.0	10.3-13.2	50.0-63.0	13.2-16.6
390F***^ (C18 ACERT)	22.2-39.4	5.9-10.4	39.4-50.5	10.4-13.3	50.5-63.7	13.3-16.8
390F****^ (C18 ACERT)	21.3-37.8	5.6-10.0	37.8-48.4	10.0-12.8	48.4-61.0	12.8-16.1

*Meets Tier 4 Final/Stage IV/Japan 2014 (Tier 4 Final) emission standards.

**Meets Tier 4 Interim/Stage IIIB/Japan 2011 (Tier 4 Interim) equivalent emission standards.

***Meets Tier 3/Stage IIIA/Japan 2006 (Tier 3) equivalent emission standards.

****Meets Tier 2/Stage II/Japan 2001 (Tier 2) equivalent emission standards.

^336EH, 336F, 336F XE, 374F and 390F hourly fuel rates are taken directly from customer machines registered on Product Link worldwide. Data from the top and bottom 5% of these customer machines has been excluded from the tables because it varies widely and therefore is not considered representative of what the remaining 90% of customers experience. Hourly fuel consumption for the 90% of machines in the tables also varies depending upon geographical region, load factor variation between units, etc. Cat machines are often used in more demanding applications which can account for differences between competitive models used in lighter duty applications. Consult your local Cat dealer for ways to more accurately estimate hourly fuel consumption for specific applications.

EXCAVATORS

Model	Low		Medium		High	
	liter	U.S. gal	liter	U.S. gal	liter	U.S. gal
TRACK MATERIAL HANDLERS						
385C MH	48-60	12.7-15.8	60-74	15.8-19.5	74-82	19.5-21.7
WHEEL HEX						
D Series						
M313D	7.5-11.6	2.0-3.1	11.6-16.4	3.1-4.3	16.4-19.2	4.3-5.1
M315D	8.7-13.1	2.3-3.5	13.1-18.1	3.5-4.8	18.1-21.0	4.8-5.6
M316D	7.9-11.8	2.1-3.1	11.8-17.1	3.1-4.5	17.1-20.3	4.5-5.4
M318D	9.1-13.3	2.4-3.5	13.3-18.2	3.5-4.8	18.2-21.7	4.8-5.7
M318D MH	9.1-13.3	2.4-3.5	13.3-18.2	3.5-4.8	18.2-21.7	4.8-5.7
M322D	11.6-17.5	3.1-4.6	17.5-23.3	4.6-6.1	23.3-26.9	6.1-7.1
M322D MH	11.6-17.5	3.1-4.6	17.5-23.3	4.6-6.1	23.3-26.9	6.1-7.1
D2 Series						
M315D2	7.5-11.6	2.0-3.1	11.6-16.4	3.1-4.3	16.4-19.2	4.3-5.1
M317D2	8.7-13.1	2.3-3.5	13.1-18.1	3.5-4.8	18.1-21.0	4.8-5.6
F Series						
M314F	4.9-7.8	1.3-2.1	7.8-8.8	2.1-2.3	8.8-11.8	2.3-3.1
M316F	6.4-8.6	1.7-2.3	8.6-9.6	2.3-2.5	9.6-12.9	2.5-3.4
M318F	5.6-8.9	1.5-2.4	8.9-11.1	2.4-2.9	11.1-13.4	2.9-3.5
M320F	5.7-9.1	1.5-2.4	9.1-11.4	2.4-3.0	11.4-13.7	3.0-3.6
M322F	7.4-10.3	2.0-2.7	10.3-11.8	2.7-3.1	11.8-14.2	3.1-3.9
MATERIAL HANDLER						
M325D MH	13-18	3.4-4.8	19-23	5.0-6.1	24-28	6.3-7.4
M325D LMH	14-20	3.7-5.3	21-26	5.5-6.9	27-32	7.1-8.5
MH3022	5.7-9.1	1.5-2.4	9.1-11.4	2.4-3.0	11.4-13.7	3.0-3.6
MH3024	7.4-10.3	2.0-2.7	10.3-11.8	2.7-3.1	11.8-14.2	3.1-3.7
MH3037	15-17	4.0-4.5	18-20	4.8-5.3	21-23	5.5-6.1
MH3049	17-19	4.5-5.0	20-22	5.3-5.8	23-25	6.1-6.6
MH3059	20-22	5.3-5.8	23-25	6.1-6.6	26-28	6.9-7.4

Mini HEX

Typical Application Description

(relative to work application)

- Low Mostly shallow depth urban utility construction where excavator sets pipe and digs in sandy loam or free flowing, low density material. Little traveling and little or no impact.
- Medium Most residential pipeline and cabling applications. Continuous mass excavation and trenching in natural bed clay soils. Some traveling and steady, full throttle operation.
- High Continuous trenching or truck loading in rock or shot rock soils. Most pipeline applications in hard rocky material. Large amount of travel over rough ground. Constant high load factor and high impact.

Load Factor Guide

(average engine load factor based on application description for each range)

- Low 20%-40%
- Medium 40%-60%
- High 60%-80%

300 Series

Typical Application Description

(relative to work application)

- Low Mostly shallow depth urban utility construction where excavator sets pipe and digs less than 50% of the daily work schedule. Sandy loam, free flowing, low density material. Little traveling and little or no impact.
- Medium Most residential sewer applications. Continuous mass excavation and trenching in natural bed clay soils. Digging 60-85% of the daily work schedule. Most log loading applications. Some traveling and steady, full throttle operation.
- High Continuous trenching or truck loading in rock or shot rock soils. Most pipeline applications in hard rocky material. Digging 90-95% of the daily work schedule. Large amount of travel over rough ground. Working on rock floor with constant high load factor and high impact.

Load Factor Guide (Tier 2, Tier 3 and Tier 4 Interim HEXSM, only)

(average engine load factor based on application description for each range)

- Low 20%-40%
- Medium 40%-60%
- High 60%-80%

M Series

Typical Application Description

(relative to work application)

- Low Urban utility construction application in sandy loam, low density material. Digging less than 50% of the daily work schedule. Rehandling and scrap handling applications.
- Medium Residential sewer applications in natural bed clay. Continuous digging in sandy clay/gravel. Digging 60-85% of the daily work schedule. Site development and lumber yard applications. Most logging applications.
- High Pipeline applications in hard rocky material. Continuous digging in rock/natural bed clay. Digging 90-95% of the daily work schedule. High impact, using hammer, working in forests and quarries.

Load Factor Guide

(average engine load factor based on application description for each range)

- Low 20%-40%
- Medium 40%-60%
- High 60%-80%

HYDRAULIC MINING SHOVELS

Model	Low		Medium		High	
	liter	U.S. gal	liter	U.S. gal	liter	U.S. gal
6015/6015 FS	66-80	17-21	80-93	21-25	93-106	25-28
6018/6018 FS	105-126	28-33	126-147	33-39	147-168	39-44
6020B	92-111	24-29	111-129	29-34	129-148	34-39
6030/6030 FS	134-161	35-43	161-188	43-50	188-215	50-57
6040/6040 FS	180-216	48-57	216-252	57-67	252-288	67-76
6050/6050 FS	229-275	60-73	275-321	73-85	321-367	85-97
6060/6060 FS	276-331	73-87	331-387	87-102	387-442	102-117
6090 FS	402-483	106-128	483-563	128-149	563-644	149-170

Typical Application Description

(relative to work application)

Low Light duty work with a considerable amount of idling.

Medium Continuous loading operations with frequent idling periods.
 (Applies for the vast majority of applications)

High Continuous hard digging operations with rare idling periods.

Load Factor Guide

(average engine load factor based on application description for each range)

Low 50%-60%

Medium 60%-70%

High 70%-80%

WHEEL TRACTOR-SCRAPERS

Model	Low		Medium		High	
	liter	U.S. gal	liter	U.S. gal	liter	U.S. gal
621K*	28.0-39.4	7.4-10.4	39.4-50.7	10.4-13.4	50.7-62.1	13.4-16.4
623K*	32.2-43.2	8.5-11.4	43.2-54.5	11.4-14.4	54.5-68.1	14.4-18.0
627K*	42.0-61.7	11.1-16.3	61.7-81.4	16.3-21.5	81.4-106.7	21.5-28.2
631G**	34.1-48.5	9.0-12.8	48.5-62.8	12.8-16.6	62.8-77.6	16.6-20.5
637G**	48.8-72.1	12.9-19.1	72.3-95.8	19.1-25.3	95.8-125.3	25.3-33.1
6257G**	66.6-98.8	17.6-26.1	98.8-131.0	26.1-34.6	131.0-163.2	34.6-43.1

*Meets Tier 4 Final/Stage IV/Japan 2014 (Tier 4 Final) emission standards. Machine requires the use of DEF fluid with consumption rate approximately 2-3% of diesel fuel.

**Meets Tier 3/Stage IIIA/Japan 2006 (Tier 3) equivalent emission standards.

Typical Application Description

(relative to work application)

- Low Level or favorable grades on good haul roads and low rolling resistance. Easy-loading materials, partial loads. No impact. Average use, but with considerable idling.
- Medium Adverse and favorable grades with varying loading and haul road conditions. Long and short hauls, near full. Some impact. Typical road building use.
- High Rough haul roads. Loading heavy clay, continuous high total resistance conditions with steady cycling. Overloading. High impact conditions, such as loading ripped rock.

Load Factor Guide

(average engine load factor based on application description for each range)

- Low 35%-50%
- Medium 50%-65%
- High 65%-80%

BACKHOE LOADERS

Model	Low		Medium		High	
	liter	U.S. gal	liter	U.S. gal	liter	U.S. gal
415F2* 55 kW/74 hp	1.9-7.5	0.5-2.0	7.5-10.5	2.0-2.8	10.5-13.9	2.8-3.7
416F2* 70 kW/94 hp	2.6-12.4	0.7-3.3	12.4-17.4	3.3-4.6	17.4-19.0	4.6-5.0
420F2*** 74.5 kW/100 hp	2.6-11.7	0.7-3.1	11.7-17.4	3.1-4.6	17.4-20.1	4.6-5.3
420F2* 74.5 kW/100 hp	2.9-13.6	0.8-3.6	13.6-18.9	3.6-5.0	18.9-19.7	5.0-5.2
422F2*** 56.5 kW/75 hp	1.9-7.9	0.5-2.1	7.9-12.1	2.1-3.2	12.1-14.4	3.2-3.8
422F2*** 68.5 kW/92 hp	2.6-11.7	0.7-3.1	11.7-16.7	3.1-4.4	16.7-18.9	4.4-5.0
427F2* 55 kW/74 hp	1.9-7.5	0.5-2.0	7.5-10.5	2.0-2.8	10.5-13.9	2.8-3.7
428F2*** 70 kW/94 hp	2.6-11.0	0.7-2.9	11.0-16.7	2.9-4.4	16.7-19.3	4.4-5.1
428F2*** 74.5 kW/100 hp	2.6-11.7	0.7-3.1	11.7-17.4	3.1-4.6	17.4-20.1	4.6-5.3
428F2** 70 kW/94 hp	2.6-11.0	0.7-2.9	11.0-16.7	2.9-4.4	16.7-19.3	4.4-5.1
428F2** 74.5 kW/100 hp	2.6-11.4	0.7-3.0	11.4-17.0	3.0-4.5	17.0-20.8	4.5-5.5
428F2* 70 kW/94 hp	2.6-12.4	0.7-3.3	12.4-17.4	3.3-4.6	17.4-19.0	4.6-5.0
428F2* 74.5 kW/100 hp	2.9-13.6	0.8-3.6	13.6-18.9	3.6-5.0	18.9-19.7	5.0-5.2
430F2*** 74.5 kW/100 hp	2.6-11.7	0.7-3.1	11.7-17.4	3.1-4.6	17.4-20.1	4.6-5.3
430F2* 86 kW/115 hp	3.1-14.8	0.8-3.9	14.8-20.9	3.9-5.5	20.9-22.8	5.5-6.0
432F2*** 74.5 kW/100 hp	2.6-11.7	0.7-3.1	11.7-17.4	3.1-4.6	17.4-20.1	4.6-5.3
432F2** 74.5 kW/100 hp	2.6-11.4	0.7-3.0	11.4-17.0	3.0-4.5	17.0-20.8	4.5-5.5
432F2* 82 kW/110 hp	2.9-13.7	0.8-3.6	13.7-19.0	3.6-5.0	19.0-21.9	5.0-5.8
434F2*** 68.5 kW/92 hp	2.6-11.7	0.7-3.1	11.7-16.7	3.1-4.4	16.7-18.9	4.4-5.0
434F2*** 74.5 kW/100 hp	2.6-11.7	0.7-3.1	11.7-17.4	3.1-4.6	17.4-20.1	4.6-5.3
434F2** 70 kW/94 hp	2.6-11.0	0.7-2.9	11.0-16.7	2.9-4.4	16.7-19.3	4.4-5.1
434F2** 74.5 kW/100 hp	2.6-11.4	0.7-3.0	11.4-17.0	3.0-4.5	17.0-20.8	4.5-5.5
434F2* 74.5 kW/100 hp	2.9-13.6	0.8-3.6	13.6-18.9	3.6-5.0	18.9-19.7	5.0-5.2
444F2*** 74.5 kW/100 hp	2.6-11.7	0.7-3.1	11.7-17.4	3.1-4.6	17.4-20.1	4.6-5.3
444F2** 74.5 kW/100 hp	2.6-11.4	0.7-3.0	11.4-17.0	3.0-4.5	17.0-20.8	4.5-5.5
444F2* 82 kW/110 hp	2.9-13.7	0.8-3.6	13.7-19.0	3.6-5.0	19.0-21.9	5.0-5.8
450F* 106 kW/142 hp	3.3-16.2	0.9-4.3	16.2-23.1	4.3-6.1	23.1-27.1	6.1-7.2

*Meets Tier 4 Final/Stage IV/Japan 2014 (Tier 4 Final) emission standards.

**Meets Tier 3/Stage IIIA/Japan 2006 (Tier 3) equivalent emission standards.

***Meets Tier 2/Stage II/Japan 2001 (Tier 2) equivalent emission standards.

Typical Application Description

(relative to work application)

Low Light duty utility applications with intermittent cycles in light to medium soil. Trenching depths less than 1.83 m (**6 feet**).

Medium General utility applications with regular cycles in medium to heavy soil. Dig depths to 3.05 m (**10 feet**). Occasional use of constant flow implements.

High Production applications or digging in rock. Dig depths over 3.05 m (**10 feet**). Long cycle times or regular use of constant flow implements.

Load Factor Guide

(average engine load factor based on application description for each range)

Low 20%-40%

Medium 40%-65%

High 65%-80%

FOREST PRODUCTS

Model	Low		Medium		High	
	liter	U.S. gal	liter	U.S. gal	liter	U.S. gal
FOREST MACHINE						
320D FM	11.5-14.0	3.0-3.7	17.0-19.0	4.5-5.0	20.5-22.5	5.4-6.0
324D FM	14.0-19.0	3.7-5.1	22.0-25.0	5.8-6.6	26.0-30.0	6.7-7.9
325D FM	14.0-19.0	3.7-5.1	23.0-27.0	6.1-7.1	27.0-32.0	7.2-8.5
568 LL ²	19.0-24.0	5.0-6.3	29.0-33.0	7.7-8.7	34.0-39.0	9.0-10.3
568 GF ²	19.0-24.0	5.0-6.3	29.0-33.0	7.7-8.7	34.0-39.0	9.0-10.3
TRACK FELLER BUNCHER						
521B ³	28.0-33.7	7.4-8.9	33.7-37.9	8.9-10.0	37.9-45.4	10.0-12.0
522B ³	28.0-33.7	7.4-8.9	33.7-37.9	8.9-10.0	37.9-45.4	10.0-12.0
541 Series 2 ³	28.4-34.1	7.5-9.0	34.1-41.6	9.0-11.0	41.6-54.1	11.0-14.3
552 Series 2 ³	30.7-34.1	8.1-9.0	34.1-43.5	9.0-11.5	43.5-56.8	11.5-15.0
WHEEL FELLER BUNCHER						
553C ³	18.9-22.7	5.0-6.0	22.7-26.5	6.0-7.0	26.5-32.2	7.0-8.5
563C ²	18.9-22.7	5.0-6.0	22.7-26.5	6.0-7.0	26.5-32.2	7.0-8.5
573C ²	18.9-22.7	5.0-6.0	22.7-26.5	6.0-7.0	26.5-32.2	7.0-8.5
TRACK SKIDDERS						
527	13.2-18.9	3.5-5.0	18.9-23.6	5.0-6.25	23.6-32.2	6.25-8.5
WHEEL SKIDDERS						
525D ¹	15.1-17.8	4.0-4.7	17.8-20.8	4.7-5.5	20.8-24.6	5.5-6.5
535D ¹	16.3-18.9	4.3-5.0	18.9-22.0	5.0-5.8	22.0-24.6	5.8-6.5
545D ¹	17.0-19.7	4.5-5.2	19.7-23.8	5.2-6.3	23.8-27.3	6.3-7.2
555D ¹	18.9-21.6	5.0-5.7	21.6-24.6	5.7-6.5	24.6-28.4	6.5-7.5
525D ³	14.3-17.0	3.8-4.5	17.0-20.0	4.5-5.3	20.0-23.8	5.3-6.3
535D ³	15.5-18.1	4.1-4.8	18.1-21.2	4.8-5.6	21.2-23.8	5.6-6.3
545D ³	16.2-18.9	4.3-5.0	18.9-23.0	5.0-6.1	23.0-26.5	6.1-7.0
555D ³	18.1-20.8	4.8-5.5	20.8-23.8	5.5-6.3	23.8-27.6	6.3-7.3
KNUCKLEBOOM LOADER						
529 ³	12.04	3.31	19.47	5.36	25.58	7.04
559C ²	12.91	3.55	19.69	5.42	25.96	7.15
579 ²	12.91	3.55	19.69	5.42	25.96	7.15
TRACK HARVESTER						
501HD ³	13.2-15.1	3.5-4.0	15.1-17.0	4.0-4.5	17.0-20.8	4.5-5.5
521B ³	20.8-26.5	5.5-7.0	26.5-32.2	7.0-8.5	32.2-41.6	8.5-11.0
522B ³	20.8-26.5	5.5-7.0	26.5-32.2	7.0-8.5	32.2-41.6	8.5-11.0
541 Series 2 ³	24.6-30.3	6.5-8.0	30.3-36.0	8.0-9.5	36.0-45.4	9.5-12.0
552 Series 2 ³	24.6-30.3	6.5-8.0	30.3-36.0	8.0-9.5	36.0-45.4	9.5-12.0
WHEEL HARVESTER						
	—	—	—	—	—	—
FORWARDERS						
564 ³	13.2	3.5	15.0	4.0	17.0	4.5
574 ³	14.4	3.8	15.9	4.2	17.8	4.7
584 ³	12.5	3.3	14.0	3.7	17.0	4.5
584HD ³	13.0	3.4	14.3	3.8	18.9	5.0
SITE PREP TRACTORS						
586C ¹	26.5-32.2	7.0-8.5	32.2-37.9	8.5-10.0	37.9-43.5	10.0-11.5
586C ³	24.6-30.3	6.5-8.0	30.3-36.0	8.0-9.5	36.0-41.6	9.5-11.0

¹ Meets Tier 4 Final/Stage IV/Japan 2014 (Tier 4 Final) emission standards.

² Meets Tier 4 Interim/Stage IIIB/Japan 2011 (Tier 4 Interim) equivalent emission standards.

³ Meets Tier 3/Stage IIIA/Japan 2006 (Tier 3) equivalent emission standards.

Wheel Skidders

Typical Application Description

(relative to work application)

- Low Intermittent skidding for short distances, no decking. Good underfoot conditions; dry floor, few if any stumps, flat/level terrain with low skidding resistance.
- Medium Continuous turning, steady skidding for medium distances with moderate decking. Good underfoot conditions; dry floor with few stumps, gradual rolling/moderate terrain with medium skidding resistance.
- High Continuous turning, steady skidding for long distances with frequent decking. Poor underfoot conditions; wet floor, numerous stumps, steep terrain with high skidding resistance.

Load Factor Guide — 517

- Low Skidding loads less than 4536 kg (**10,000 lb**) in flat terrain (0-8% grade) with low skidding resistance.
- Medium Skidding loads up to 4536 kg (**10,000 lb**) in moderate terrain (8-30% grade) with medium skidding resistance.
- High Skidding loads over 4536 kg (**10,000 lb**) in steep terrain (over 30% grade) with high skidding resistance.

Load Factor Guide — D Series WSK

- Low Skidding loads less than 6350 kg (**14,000 lb**) in flat terrain (0-5% grade) with low skidding resistance.
- Medium Skidding loads up to 7257 kg (**16,000 lb**) in moderate terrain (5-10% grade) with average skidding resistance
- High Skidding loads over 8165 kg (**18,000 lb**) in steep terrain (over 10% grade) with high skidding resistance.

Load Factor Guide — 527

- Low Skidding loads less than 6360 kg (**14,000 lb**) in flat terrain (0-8% grade) with low skidding resistance.
- Medium Skidding loads up to 6360 kg (**14,000 lb**) in moderate terrain (8-30% grade) with medium skidding resistance.
- High Skidding loads over 6360 kg (**14,000 lb**) in steep terrain (over 30% grade) with high skidding resistance.

Forest Machines

Typical Application Description

(relative to work application)

- Low Millyard application or log loader in best underfoot conditions. Flat ground, uniform cut processed lengths 12 m (**40 feet**), or shorter.
- Medium Light to medium shovel or log loader application in better underfoot conditions. Medium slopes and trees 500 mm (**20 inches**) or medium size full trees.
- High Heavy shovel logging in poor underfoot conditions, steep terrain, over stumps or fallen trees. Multiple large full trees with DBH of 635 mm (**25 inches**) or larger.

Load Factor Guide

(average engine load factor based on application description for each range)

- Low 25%-45%
- Medium 45%-65%
- High 65%-85%

Track Feller Bunchers

Typical Application Description

(relative to work application)

- Low Intermittent felling and stacking, good underfoot conditions and flat ground. Uniform trees below 255 mm (**10 inches**).
- Medium Feller buncher applications in average underfoot conditions and rolling terrain. Some trees up to 457 mm (**18 inches**).
- High High cycle feller buncher applications in poor underfoot conditions, steep terrain, maneuvering over stumps, rocks and fallen trees. Accumulation of multiple small diameter trees or individual harvest of larger trees, including hardwoods, over 508 mm (**20 inches**).

Load Factor Guide

(average engine load factor based on application description for each range)

- Low 45%-65%
- Medium 65%-85%
- High 85%-98%

Track Harvesters

Typical Application Description

(relative to work application)

- Low Light duty harvesting and processing applications in good underfoot conditions and flat ground. Primarily uniform softwood trees below 255 mm (**10 inches**).
- Medium Harvesting and processing applications in average underfoot conditions and rolling terrain. Primarily softwood trees and a few hardwoods up to 457 mm (**18 inches**).
- High High cycling harvesting and processing in poor underfoot conditions, steep terrain, maneuvering over stumps, rocks and fallen trees. Multiple small diameter trees or individual harvest of larger trees, including hardwoods, over 508 mm (**20 inches**).

Load Factor Guide

(average engine load factor based on application description for each range)

- Low 38%-55%
- Medium 55%-72%
- High 72%-83%

Forwarders

Typical Application Description

(relative to work application)

- Low Loading and hauling application in good conditions. Flat ground, concentrated log bunches, single tier log lengths, short haul distances.
- Medium Loading and hauling application in medium conditions. Rolling terrain, medium spacing of log bunches, single and two tier log lengths.
- High Loading and hauling application in poor conditions, steep or rocky terrain, scattered log bunches, two tier log lengths, long haul distances.

Load Factor Guide

(average engine load factor based on application description for each range)

- Low 15%-25%
- Medium 25%-35%
- High 35%-45%

MINING & OFF-HIGHWAY TRUCKS

Model	Low		Medium		High	
	liter	U.S. gal	liter	U.S. gal	liter	U.S. gal
770G ^{1†}	19.7-29.5	5.2-7.7	29.5-39.3	7.7-10.3	39.3-49.2	10.3-12.9
770G ^{2,3}	18.3-27.5	4.8-7.3	27.5-36.6	7.3-9.7	36.6-45.8	9.7-12.1
772G ^{1†}	23.5-35.3	6.2-9.3	35.3-47.1	9.3-12.4	47.1-58.9	12.4-15.4
772G ^{2,3}	22.0-32.9	5.8-8.7	32.9-43.9	8.7-11.6	43.9-54.9	11.6-14.5
773E ³	27.4-41.2	7.2-10.9	41.2-54.9	10.9-14.5	54.9-68.6	14.5-18.1
773G ⁵	29.0-43.5	7.7-11.5	43.5-58.0	11.5-15.3	58.0-72.5	15.3-19.2
773G ¹	29.0-43.5	7.7-11.5	43.5-58.1	11.5-15.4	58.1-72.6	15.4-19.2
775G ⁵	30.9-46.3	8.2-12.2	46.3-61.7	12.2-16.3	61.7-77.1	16.3-20.4
775G ¹	30.9-46.4	8.2-12.3	46.4-61.9	12.3-16.4	61.9-77.4	16.4-20.4
777D ⁴	37.5-56.3	9.9-14.9	56.3-75.0	14.9-19.8	75.0-93.8	19.8-24.8
777G ⁵	37.5-56.2	9.9-14.8	56.2-75.0	14.8-19.8	75.0-93.7	19.8-24.8
777G ¹	38.7-58.0	10.2-15.3	58.0-77.4	15.3-20.4	77.4-96.7	20.4-25.5
785C 1450 HP ⁴	53.7-80.6	14.2-21.3	80.6-107.5	21.3-28.4	107.5-134.4	28.4-35.5
785D 1450 HP ⁵	54.2-81.4	14.3-21.5	81.4-108.5	21.5-28.7	108.5-135.6	28.7-35.8
789D 1900 HP ⁴	70.6-105.9	18.7-28.0	105.9-141.2	28.0-37.3	141.2-176.5	37.3-46.6
789D 2100 HP ⁴	74.9-112.4	19.8-29.7	112.4-149.9	29.7-39.6	149.9-187.4	39.6-49.5
789D 2100 HP ⁵	79.7-119.5	21.1-31.6	119.5-159.3	31.6-42.1	159.3-199.1	42.1-52.6
793D 2160 HP ⁴	82.2-123.3	21.7-32.6	123.3-164.4	32.6-43.4	164.4-205.5	43.4-54.3
793D 2270 HP ⁴	86.0-129.0	22.7-34.1	129.0-172.0	34.1-45.4	172.0-215.0	45.4-56.8
793D 2415 HP ⁴	90.8-136.2	24.0-36.0	136.2-181.6	36.0-48.0	181.6-227.0	48.0-60.0
793F 2270 HP ⁴	82.4-123.7	21.8-32.7	123.7-164.9	32.7-43.6	164.9-206.1	43.6-54.5
793F 2270 HP ⁵	87.2-130.8	23.0-34.6	130.8-174.4	34.6-46.1	174.4-218.0	46.1-57.6
793F 2650 HP ⁴	95.0-142.5	25.1-37.6	142.5-190.0	37.6-50.2	190.0-237.6	50.2-62.8
793F 2650 HP ⁵	96.8-145.2	25.6-38.4	145.2-193.6	38.4-51.1	193.6-242.0	51.1-63.9
793F HAA 2650 HP ⁴	90.7-136.0	24.0-35.9	136.0-181.4	35.9-47.9	181.4-226.7	47.9-59.9
795F 3100 HP ⁴	113.0-169.5	29.9-44.8	169.5-226.1	44.8-59.7	226.1-282.6	59.7-74.7
795F 3100 HP ⁵	113.1-169.7	29.9-44.8	169.7-226.3	44.8-59.8	226.3-282.8	59.8-74.7
795F 3400 HP ⁴	124.4-186.6	32.9-49.3	186.6-248.8	49.3-65.7	248.8-311.0	65.7-82.2
795F 3400 HP ⁵	124.4-186.6	32.9-49.3	186.6-248.8	49.3-65.7	248.8-311.0	65.7-82.2
795F HAA 3400 HP ⁴	121.4-182.1	32.1-48.1	182.1-242.8	48.1-64.1	242.8-303.6	64.1-80.2
797B 3550 HP ⁴	133.5-200.2	35.3-52.9	200.2-266.9	52.9-70.5	266.9-333.6	70.5-88.1
797F 3550 HP ⁴	126.0-189.1	33.3-50.0	189.1-252.1	50.0-66.6	252.1-315.1	66.6-83.2
797F 3550 HP ⁵	131.5-197.3	34.7-52.1	197.3-263.0	52.1-69.5	263.0-328.8	69.5-86.9
797F 4000 HP ⁴	143.1-214.6	37.8-56.7	214.6-286.2	56.7-75.6	286.2-357.7	75.6-94.5
797F 4000 HP ⁵	146.3-219.4	38.7-58.0	219.4-292.5	58.0-77.3	292.5-365.7	77.3-96.6
797F HAA 4000 HP ⁵	147.9-221.8	39.1-58.6	221.8-295.8	58.6-78.2	295.8-369.7	78.2-97.7

Sea Level data only, power and fuel will change with altitude.

Value is product of load factor and rated power fuel burn, actual fuel burn will vary with engine speed and load.

It is recommended to use FPC (Fleet Productivity and Cost analysis) software for the best cycle and hourly fuel burn calculations.

HAA = High Altitude Engine Arrangement

¹ Meets Tier 4 Final/Stage IV/Japan 2014 (Tier 4 Final) equivalent emission standards.

² Meets Tier 3/Stage IIIA/Japan 2006 (Tier 3) equivalent emission standards.

³ Meets Tier 2/Stage II/Japan 2001 (Tier 2) equivalent emission standards.

⁴ Meets Tier 1 equivalent emission standards.

⁵ Meets Tier 2 equivalent emission standards.

†Machine requires the use of DEF with a consumption rate approximately 2-3% of diesel fuel.

Mining & Off-Highway Trucks

Typical Application Description

(relative to work application)

- Low Continuous operation at an average gross weight less than recommended. Excellent haul roads. No overloading, low load factor.
- Medium Continuous operation at an average gross weight approaching recommended. Minimal overloading, good haul roads, moderate load factor.
- High Continuous operation at or above maximum recommended gross weight. Overloading, poor haul roads, high load factor.

Load Factor Guide

(average engine load factor based on application description for each range)

- Low 20%-30%
- Medium 30%-40%
- High 40%-50%

NOTE: For best results, use Caterpillar Fleet Production and Cost Analysis (FPC) to simulate cycle time, fuel burn, and production. For Application Specific Performance inquiries, contact Factory Representative or visit catminer.cat.com/stb for more information.

ARTICULATED TRUCKS

Model	Low		Medium		High	
	liter	U.S. gal	liter	U.S. gal	liter	U.S. gal
725 ³	8.8-14.7	2.3-3.9	14.7-23.5	3.9-6.2	23.5-29.4	6.2-7.8
725C ⁴	8.3-14.0	2.2-3.7	14.0- 22.6	3.7-6.0	22.6-29.8	6.0-7.9
725C ¹	8.6-14.6	2.3-3.9	14.6- 23.5	3.9-6.2	23.5-31.0	6.2-8.2
730 ³	9.3-15.6	2.5-4.1	15.6-24.9	4.1-6.6	24.9-31.1	6.6-8.2
730C ⁴	8.9-14.8	2.4-3.9	14.8-24.2	3.9-6.4	24.2-30.9	6.4-8.2
730C ¹	9.4-15.7	2.5-4.1	15.7-25.5	4.1-6.7	25.5-32.5	6.7-8.6
730 E ³	10.0-14.6	2.6-3.9	14.6-24.8	3.9-6.6	24.8-30.0	6.6-7.9
730C E ⁴	9.5-13.9	2.5-3.7	13.9-24.1	3.7-6.4	24.1-29.0	6.4-7.7
730C E ¹	10.0-14.7	2.6-3.9	14.7-25.4	3.9-6.7	25.4-31.2	6.7-8.2
735 ³	12.4-20.7	3.3-5.5	20.7-33.2	5.5-8.8	33.2-41.5	8.8-11.0
735B ⁴	11.5-19.1	3.0-5.0	19.1-30.5	5.0-8.1	30.5-38.2	8.1-10.1
735B ²	12.4-20.7	3.3-5.5	20.7-33.2	5.5-8.8	33.2-41.5	8.8-11.0
735C ⁴	11.5-19.1	3.0-5.0	19.1-30.5	5.0-8.1	30.5-38.2	8.1-10.1
735C ¹	12.2-20.2	3.2-5.3	20.2-32.4	5.3-8.6	32.4-40.5	8.6-10.7
740 ³	13.5-22.5	3.6-6.0	22.5-36.1	6.0-9.5	36.1-45.1	9.5-11.9
740 E ³	14.4-23.4	3.8-6.2	23.4-37.0	6.2-9.8	37.0-45.1	9.8-11.9
740B ⁴	12.2-20.3	3.2-5.4	20.3-32.5	5.4-8.6	32.5-40.6	8.6-10.7
740B ²	13.5-22.5	3.6-6.0	22.5-36.1	6.0-9.5	36.1-45.1	9.5-11.9
740B E ⁴	12.2-20.3	3.2-5.4	20.3-32.5	5.4-8.6	32.5-40.6	8.6-10.7
740B E ²	13.9-23.2	3.7-6.1	23.2-37.1	6.1-9.8	37.1-46.4	9.8-12.3
740C E ⁴	12.5-20.8	3.3-5.5	20.8-33.3	5.5-8.8	33.3-41.6	8.8-11.0
740C E ¹	13.6-22.6	3.6-6.0	22.6-36.2	6.0-9.6	36.2-45.2	9.6-12.0
745C ⁴	12.5-20.8	3.3-5.5	20.8-33.3	5.5-8.8	33.3-41.6	8.8-11.0
745C ¹	13.6-22.6	3.6-6.0	22.6-36.2	6.0-9.6	36.2-45.2	9.6-12.0

¹ Meets Tier 4 Final/Stage IV/Japan 2014 (Tier 4 Final) emission standards.

² Meets Tier 4 Interim/Stage IIIB/Japan 2011 (Tier 4 Interim) equivalent emission standards.

³ Meets Tier 3/Stage IIIA/Japan 2006 (Tier 3) equivalent emission standards.

⁴ Meets Tier 2/Stage II equivalent emission standards.

Typical Application Description

(relative to work application)

- Low Earthmoving and stockpile use with well matched loading equipment, free flowing material. Large amount of idling, short to medium haul distances on well-maintained level haul roads. Minimum total resistance, few impact loads.
- Medium Typical use in road-building, dam construction, open-pit mining, etc. Normal load and haul times, varying haul road conditions with some adverse grades. Some impact loads.
- High Poorly-matched loading equipment with continuous overloading. Long haul time and continuous use on very poorly maintained haul roads with frequent adverse grades. High rolling resistance, poor traction, high impact loads.

Load Factor Guide

(average engine load factor based on application description for each range)

- Low 15%-25%
- Medium 25%-40%
- High 40%-50%

TELEHANDLERS

Model	Low		Medium		High	
	liter	U.S. gal	liter	U.S. gal	liter	U.S. gal
TH210	5.1-6.8	1.3-1.8	8.5-10.1	2.2-2.6	11.8-13.5	3.1-3.5
TH215	5.1-6.8	1.3-1.8	8.5-10.1	2.2-2.6	11.8-13.5	3.1-3.5
TH220B (59-74 kW/80-99 hp)	5.0-7.0	1.3-1.8	10.0-14.0	2.6-3.7	13.0-17.0	3.4-4.5
TH220B (92 kW/123 hp)	5.0-8.0	1.3-2.1	10.0-16.0	2.6-4.2	13.0-20.0	3.4-5.3
TH330B (59-74 kW/80-99 hp)	5.0-7.0	1.3-1.8	10.0-14.0	2.6-3.7	13.0-17.0	3.4-4.5
TH330B (92 kW/123 hp)	5.0-8.0	1.3-2.1	10.0-16.0	2.6-4.2	13.0-20.0	3.4-5.3
TH340B	5.0-7.0	1.3-1.8	10.0-14.0	2.6-3.7	13.0-17.0	3.4-4.5
TH350B	5.0-7.0	1.3-1.8	10.0-14.0	2.6-3.7	13.0-17.0	3.4-4.5
TH355B	5.0-7.0	1.3-1.8	10.0-14.0	2.6-3.7	13.0-17.0	3.4-4.5
TH360B	5.0-7.0	1.3-1.8	10.0-14.0	2.6-3.7	13.0-17.0	3.4-4.5
TH460B	5.0-7.0	1.3-1.8	10.0-14.0	2.6-3.7	13.0-17.0	3.4-4.5
TH560B (59-74 kW/80-99 hp)	5.0-9.0	1.3-2.4	10.0-15.0	2.6-4.0	13.0-17.5	3.4-4.6
TH560B (92 kW/123 hp)	5.0-9.0	1.3-2.4	10.0-17.0	2.6-4.5	13.0-21.0	3.4-5.5
TH580B	5.0-6.0	1.3-1.6	9.0-10.7	2.4-2.8	16.0-18.3	4.2-4.8

Typical Application Description

(relative to work application)

Low Light to moderate, intermittent, utility applications with frequent periods of idling and limited travel.

Medium General construction applications with moderate amounts of travel.

High Continuous production applications with near capacity loading and extended lifts.

Load Factor Guide

(average engine load factor based on application description for each range)

Low 20%-30%

Medium 30%-40%

High 40%-50%

WHEEL DOZERS/SOIL COMPACTORS/LANDFILL COMPACTORS

Model	Low		Medium		High	
	liter	U.S. gal	liter	U.S. gal	liter	U.S. gal
814F	21.0-25.0	5.5-6.5	26.0-30.0	7.0-8.0	36.0-40.0	9.5-10.5
815F	26.0-30.0	7.0-8.0	36.0-42.0	9.5-11.0	44.0-47.0	11.5-12.5
816F	26.0-30.0	7.0-8.0	36.0-42.0	9.5-11.0	44.0-47.0	11.5-12.5
824K	28.9-33.8	7.9-8.9	39.8-45.8	10.5-12.1	53.7-59.7	14.2-15.8
824K	37.8-43.8	10.0-11.6	53.7-67.3	14.2-17.8	63.7-69.7	16.8-18.4
826K	34.0-35.8	8.4-9.4	39.8-43.8	10.5-11.6	47.8-51.7	12.6-13.6
834K	34.6-43.4	9.1-11.4	48.2-52.2	12.7-13.8	67.6-74.0	17.8-19.5
836H	39.8-43.8	10.5-11.6	47.8-51.7	12.6-14.0	55.7-59.7	14.7-18.0
844K	42.0-50.0	11.0-13.0	54.0-62.0	14.0-16.0	65.0-73.0	17.0-19.0
854K	49.2-64.4	13.0-17.0	64.4-79.5	17.0-21.0	79.5-94.6	21.0-25.0

Wheel Dozers

Typical Application Description

(relative to work application)

- Low Light utility and stockpile work. Pulling compactors. Dozing loose fill. Considerable idling or travel with no load and no impact.
- Medium Production dozing, push loading in clays, sands, silts, loose gravels. Shovel clean-up. Normal compaction.
- High Heavy production dozing in rock. Push-loading in rocky, bouldery borrow pits. Heavy landfill compactor work. High impact conditions.

Load Factor Guide

(average engine load factor based on application description for each range)

- Low 35%-50%
- Medium 50%-65%
- High 65%-80%

Soil Compactors/Landfill Compactors

Typical Application Description

(relative to work application)

- Low No dozing or very light spreading on a flat or downhill surface. Machine has support equipment dozing and spreading trash while compactor simply travels over flat surface multiple times.
- Medium Compactor primary use is compacting already spread material. Compactor assists in dozing and spreading during peak periods of day and possibly working slopes of no steeper than a 4:1.
- High Compactor is possibly only machine for operation. Machine will doze and spread material alone and then compact it with multiple passes working on steep slopes and possibly uphill.

Load Factor Guide

(average engine load factor based on application description for each range)

- Low 35%-50%
- Medium 50%-65%
- High 65%-80%

COMPACTION EQUIPMENT

Model	Low		Medium		High	
	liter	U.S. gal	liter	U.S. gal	liter	U.S. gal
SOIL COMPACTORS						
CS-323C	8.0-13.0	2.0-3.5	11.0-15.0	3.0-4.0	11.0-19.0	3.0-5.0
CS34	4.9-6.1	1.3-1.6	6.1-9.1	1.6-2.4	9.1-12.9	2.4-3.4
CP-323C	8.0-13.0	2.0-3.5	11.0-15.0	3.0-4.0	11.0-19.0	3.0-5.0
CP34	4.9-6.1	1.3-1.6	6.1-9.1	1.6-2.4	9.1-12.9	2.4-3.4
CS-423E	4.5-6.4	1.2-1.7	6.4-9.5	1.7-2.5	9.5-12.9	2.5-3.4
CS-533E	5.7-9.5	1.5-2.5	9.5-13.2	2.5-3.5	13.2-17.0	3.5-4.5
CP-533E	5.7-9.5	1.5-2.5	9.5-13.2	2.5-3.5	13.2-17.0	3.5-4.5
CS44	5.8-7.8	1.5-2.1	7.8-11.9	2.1-3.1	11.9-15.7	3.1-4.2
CS44B	6.1-7.2	1.6-1.9	7.2-11.0	1.9-2.9	11.0-15.5	2.9-4.1
CP44	5.8-7.8	1.5-2.1	7.8-11.9	2.1-3.1	11.9-15.7	3.1-4.2
CP44B	6.1-7.2	1.6-1.9	7.2-11.0	1.9-2.9	11.0-15.5	2.9-4.1
CS54	5.7-9.5	1.5-2.5	9.5-13.2	2.5-3.5	13.2-17.0	3.5-4.5
CS56	7.6-9.5	2.0-2.5	9.5-15.1	2.5-4.0	15.1-22.7	4.0-6.0
CP56	7.6-9.5	2.0-2.5	9.5-15.1	2.5-4.0	15.1-22.7	4.0-6.0
CS64	7.6-9.5	2.0-2.5	9.5-15.1	2.5-4.0	15.1-26.5	4.0-7.0
CP64	7.6-9.5	2.0-2.5	9.5-15.1	2.5-4.0	15.1-26.5	4.0-7.0
CS74	9.5-11.4	2.5-3.0	11.4-15.1	3.0-4.0	15.1-26.5	4.0-7.0
CP74	9.5-11.4	2.5-3.0	11.4-15.1	3.0-4.0	15.1-26.5	4.0-7.0
CS76	11.4-13.3	3.0-3.5	13.3-17.0	3.5-4.5	17.0-26.5	4.5-7.0
CP76	11.4-13.3	3.0-3.5	13.3-17.0	3.5-4.5	17.0-26.5	4.5-7.0
CS76 XT	11.4-13.3	3.0-3.5	13.3-17.0	3.5-4.5	17.0-26.5	4.5-7.0
CS54B	6.3-10.5	1.7-2.8	10.5-14.5	2.8-3.9	14.5-18.7	3.9-5.0
CP54B	6.3-10.5	1.7-2.8	10.5-14.5	2.8-3.9	14.5-18.7	3.9-5.0
CS56B	8.4-10.5	2.2-2.8	10.5-16.6	2.8-4.4	16.6-25.0	4.4-6.6
CP56B	8.4-10.5	2.2-2.8	10.5-16.6	2.8-4.4	16.6-25.0	4.4-6.6
CS64B	6.3-10.5	1.7-2.8	10.5-14.5	2.8-3.9	14.5-18.7	3.9-5.0
CS66B	8.4-10.5	2.2-2.8	10.5-16.6	2.8-4.4	16.6-25.0	4.4-6.6
CS68B	8.4-10.5	2.2-2.8	10.5-16.6	2.8-4.4	16.6-29.2	4.4-7.7
CP68B	8.4-10.5	2.2-2.8	10.5-16.6	2.8-4.4	16.6-29.2	4.4-7.7
CS74B	10.5-12.5	2.8-3.3	12.5-16.6	3.3-4.4	16.6-29.2	4.4-7.7
CP74B	10.5-12.5	2.8-3.3	12.5-16.6	3.3-4.4	16.6-29.2	4.4-7.7
CS76B	12.5-14.9	3.3-3.9	14.9-18.7	3.9-5.0	18.7-29.2	5.0-7.7
CS78B	12.5-14.9	3.3-3.9	14.9-18.7	3.9-5.0	18.7-29.2	5.0-7.7
CS79B	12.5-14.9	3.3-3.9	14.9-18.7	3.9-5.0	18.7-29.2	5.0-7.7

COMPACTION EQUIPMENT

Model	Low		Medium		High	
	liter	U.S. gal	liter	U.S. gal	liter	U.S. gal
ASPHALT COMPACTORS						
CB-434D	5.7-7.6	1.5-2.0	7.6-11.4	2.0-3.0	11.4-15.2	3.0-4.0
CB-534D	5.7-7.6	1.5-2.0	7.6-11.4	2.0-3.0	11.4-15.2	3.0-4.0
CB-534D XW	5.7-7.6	1.5-2.0	7.6-11.4	2.0-3.0	11.4-15.2	3.0-4.0
CB-564D	8.6	2.3	10.4	2.8	13.3	3.5
CB54	8.5	2.2	9.4	2.5	11.0	2.9
CB54 XW	8.2	2.2	9.4	2.5	11.0	2.9
CB64	8.5	2.2	9.4	2.5	12.9	3.4
CB44B	6.8	1.8	8.3	2.2	10.2	2.7
CD44B	6.8	1.8	8.3	2.2	10.2	2.7
CB54B	7.9	2.1	9.5	2.5	10.9	2.9
CD54B	6.8	1.8	8.3	2.2	10.2	2.7
CB64B	8.2	2.2	9.4	2.5	11.0	2.9
CB66B	8.5	2.2	9.4	2.5	12.9	3.4
CB68B	8.5	2.2	9.4	2.5	12.9	3.4
PNEUMATIC TIRED COMPACTORS						
PS-150C	8.0-11.0	2.0-3.0	11.0-13.0	3.0-3.5	13.0-15.0	3.5-4.0
PS-300C	13.0-15.0	3.5-4.0	15.0-17.0	4.0-4.5	17.0-23.0	4.5-6.0
PF-300C	13.0-15.0	3.5-4.0	15.0-17.0	4.0-4.5	17.0-23.0	4.5-6.0
PS-360C	7.4-9.8	1.9-2.6	9.8-12.4	2.6-3.3	12.4-14.5	3.3-4.6
CW14	8.0-11.0	2.1-2.9	11.0-13.0	2.9-3.4	13.0-15.0	3.4-4.0
CW34	7.4-9.8	2.0-2.6	9.8-12.4	2.6-3.3	12.4-14.5	3.3-3.8

Asphalt Compactors

Typical Application Description

(relative to work application)

- Low Asphalt mix, 25-50 mm **(1-2 inch)** lifts. Static finish rolling, all lifts.
- Medium Asphalt mix, 51-100 mm **(2-4 inch)** lifts.
- High Asphalt mix, 101-150 mm **(4-6 inch)** lifts. Prepare granular base lifts.

Vibratory Soil Compactors

Typical Application Description

(relative to work application)

- Low Granular soil not compacted to high density (<95 Proctor). Residential street work with lift thicknesses from 51-100 mm **(2-4 inch)** working the initial compaction. Level ground, minimal slopes and intermittent periods of waiting for base work completion or material delivery. Speeds in the middle of the low range (2-3 km/h [1-2 mph]). Minimal start and stop of the vibrate function.
- Medium Granular soil compacted to density (>95 Proctor). Cohesive soils with padded drum and low normal moisture content, blading <25%. Continuous operation on thicker lifts 101-200 mm **(4-8 inch)** or doing the final passes on stiffer materials or working at the top end of the low speed range. Working on slopes greater than 5% or rapid directional changes combined with start and stop of the vibrate function.
- High Cohesive soil with padded drum and high moisture content. Combined high load factors from the medium duty application. Working on thick lifts 201-300 mm **(8-12 inch)**, slopes greater than 15%, or applications requiring significant blade work. An example would be trench work with backfilling.

Load Factor Guide

(average engine load factor based on application description for each range)

- Low Vibration 20-40%
- Medium Vibration 40-60%
- High Vibration 60-100%

Pneumatic Compactors

Typical Application Description

(relative to work application)

- Low Asphalt mix, all lifts. Intermediate or finish rolling, chip seal. Level ground.
- Medium Asphalt mix, all lifts. Intermediate or finish rolling. Granular base breakdown <100 mm **(<4 inch)**. Moderate grade.
- High Granular base or cold in place breakdown roller >100 mm **(4 inch)** lifts. Intermediate or finish rolling. Steep grades.

Load Factor Guide

(average engine load factor based on application description for each range)

- Low Vibration 30%-50%
- Medium Vibration 50%-80%
- High Vibration 80%-100%

COMPACTION EQUIPMENT — UTILITY COMPACTORS

Model	Low		Medium		High	
	liter	U.S. gal	liter	U.S. gal	liter	U.S. gal
CB14B, CB14B XW	1.5	0.4	1.9	0.5	2.2	0.58
CB22	4.0	1.06	5.5	1.45	7.0	1.85
CB22B*	4.0	1.06	5.5	1.45	7.0	1.85
CB24, CB24 XT	4.0	1.06	5.5	1.45	7.0	1.85
CB24B, CB24B XT*	4.0	1.06	5.5	1.45	7.0	1.85
CC24	3.0	0.79	5.0	1.32	7.0	1.85
CC24B*	3.0	0.79	5.0	1.32	7.0	1.85
CB32	4.0	1.06	5.5	1.45	7.0	1.85
CB32B*	4.0	1.06	5.5	1.45	7.0	1.85
CB34, CB34 XW	2.0-3.2	0.53-0.83	3.2-4.5	0.83-1.19	4.5-6.0	1.19-1.59
CB34B, CB34B XW*	2.0-3.2	0.53-0.83	3.2-4.5	0.83-1.19	4.5-6.0	1.19-1.59
CC34	2.0-3.2	0.53-0.83	3.2-4.5	0.83-1.19	4.5-6.0	1.19-1.59
CC34B*	2.0-3.2	0.53-0.83	3.2-4.5	0.83-1.19	4.5-6.0	1.19-1.59

*Eco-mode use provides up to 8% less fuel consumption depending on job site conditions.

Utility Compactors — CB14, CB22, CB24, CB32, CC24

Typical Application Description

(relative to work application)

- Low Asphalt mix, 25-50 mm (1-2 inch) lifts. Static finish rolling, all lifts.
- Medium Asphalt mix, 25-50 mm (1-2 inch) lifts. Normal working conditions with vibrate and static.
- High Asphalt mix, 25-50 mm (1-2 inch) lifts. May include some soil compaction.

Load Factor Guide

(average engine load factor based on application description for each range)

- Low Vibration 10-30%
- Medium Vibration 30-60%
- High Vibration 60-85%

Utility Compactors — CB34, CC34

Typical Application Description

(relative to work application)

- Low Asphalt mix, 25-50 mm (1-2 inch) lifts. Static finish rolling, all lifts.
- Medium Asphalt mix, 51-100 mm (2-4 inch) lifts.
- High Asphalt mix, 101-150 mm (4-6 inch) lifts. Prepare granular base lifts.

Load Factor Guide

(average engine load factor based on application description for each range)

- Low Vibration 20-40%
- Medium Vibration 40-70%
- High Vibration 80-100%

ASPHALT PAVERS

Model	Low		Medium		High	
	liter	U.S. gal	liter	U.S. gal	liter	U.S. gal
AP500E (106 kW/ 142 hp)	7.6-9.5	2.0-2.5	9.5-11.4	2.5-3.0	11.4-15.1	3.0-4.0
AP555E (106 kW/ 142 hp)	7.6-9.5	2.0-2.5	9.5-11.4	2.5-3.0	11.4-15.1	3.0-4.0
AP600D (129 kW/ 174 hp)	7.6-11.4	2.0-3.0	11.4-17.0	3.0-4.5	17.0-22.7	4.5-6.0
AP655D (129 kW/ 174 hp)	7.6-11.4	2.0-3.0	11.4-17.0	3.0-4.5	17.0-24.6	4.5-6.5
AP1000D (167 kW/ 224 hp)	9.5-15.1	2.5-4.0	15.1-18.9	4.0-5.0	18.9-24.6	5.0-6.5
AP1055D (167 kW/ 224 hp)	9.5-15.1	2.5-4.0	15.1-18.9	4.0-5.0	18.9-26.5	5.0-7.0
AP1000E (168 kW/ 225 hp)	9.5-15.1	2.5-4.0	15.1-18.9	4.0-5.0	18.9-24.6	5.0-6.5
AP1055E (168 kW/ 225 hp)	9.5-15.1	2.5-4.0	15.1-18.9	4.0-5.0	18.9-26.5	5.0-7.0

NOTE: The above fuel usage rates assume typical idle times for screed warm up and machine clean up.

Typical Application Description

(relative to work application)

Low Narrow width paving, low production.

Medium 3-4 m (**10-12 feet**) width, 50-75 mm (**2-3 inch**) lift.

High Wide width, deep lift paving.

Load Factor Guide

(average engine load factor based on application description for each range)

Low 20%-30%

Medium 30%-40%

High 40%-50%

⑧ Hourly Fuel Consumption Tables
 ● Cold Planers
 ● Road Reclaimers/Soil Stabilizers

Owning & Operating Costs

COLD PLANERS

Model	Low		Medium		High	
	liter	U.S. gal	liter	U.S. gal	liter	U.S. gal
PM102	15.6-22.3	4.1-5.9	22.3-29.0	5.9-7.7	29.0-35.7	7.7-9.4
PM200	38.7-55.3	10.2-14.6	55.3-71.8	14.6-19.0	71.8-88.4	19.0-23.4
PM201	45.5-60.6	12.0-16.0	60.6-83.4	16.0-22.0	83.4-106.1	22.0-28.0

Typical Application Description

(relative to work application)

Low 50 mm (**2 inches**) or less cutting depth, 80% load cycle.

Medium 100 mm (**4 inches**) cutting depth.

High Steady, full depth.

Load Factor Guide

(average engine load factor based on application description for each range)

Low 35%-50%

Medium 50%-65%

High 65%-80%

ROAD RECLAIMERS/SOIL STABILIZERS

Model	Low		Medium		High	
	liter	U.S. gal	liter	U.S. gal	liter	U.S. gal
RM300	26.5-34.1	7.0-9.0	34.1-41.6	9.0-11.0	41.6-53.0	11.0-14.0
RM350B	53.1-68.2	14.0-18.0	68.2-83.4	18.0-22.0	83.4-94.8	22.0-25.0
RM500	45.4-56.7	12.0-15.0	60.5-68.1	16.0-18.0	75.7-87.1	20.0-23.0
RM500B	48.6-80.2	12.8-21.2	68.1-97.7	18.0-25.8	85.4-106.9	22.6-28.2

Typical Application Description

(relative to work application)

Low 150 mm (**6 inches**) soil/100 mm (**4 inches**) asphalt.

Medium 305 mm (**12 inches**) soil/150 mm (**6 inches**) asphalt.

High 457 mm (**18 inches**) soil/305 mm (**12 inches**) asphalt.

Load Factor Guide

(average engine load factor based on application description for each range)

Low 35%-60%

Medium 60%-80%

High 80%-90%

TRACK LOADERS

Model	Low		Medium		High	
	liter	U.S. gal	liter	U.S. gal	liter	U.S. gal
953D	12.2-19.1	3.2-5.1	19.1-24.4	5.1-6.4	24.4-29.6	6.4-7.8
963D	15.7-22.5	4.2-5.9	24.7-29.2	6.5-7.7	29.2-36.0	7.7-9.5
973D	24.5-28.4	6.5-7.5	28.4-37.8	7.5-10.0	37.8-45.0	10.0-11.9

Typical Application Description

(relative to work application)

- Low Site clearing of small vegetation, stripping top soil, carrying to stockpile. Backfilling and grading. Intermittent truck loading from stockpile. Free flowing, low density materials with standard bucket. Large amounts of idling. No impact.
- Medium Bank excavation, bank or stockpile loading. Intermittent ripping, basement digging of natural bed clays, sands, silts, gravels. Load and carry. Steady full throttle operation.
- High Loading shot rock, cobbles, glacial till, caliche. Continuous work on rock surfaces. Continuous excavating and loading from bank. High density materials in standard bucket. Land clearing and steel mill work. Large amount of ripping in tight, rocky materials. High impact conditions.

Load Factor Guide

(average engine load factor based on application description for each range)

- Low 35%-50%
- Medium 50%-65%
- High 65%-80%

Product Link Information — Product Link measured over hundreds of Track-Type Loaders shows that more than 90% of the machines experience an average fuel consumption equal to or lower than those shown in the Low Application profile.

WHEEL LOADERS AND INTEGRATED TOOLCARRIERS

Model	Low		Medium		High	
	liter	U.S. gal	liter	U.S. gal	liter	U.S. gal
901C (Japan only)	0.0-1.5	0.0-0.4	1.5-3.4	0.4-0.9	3.4-4.9	0.9-1.3
902C (Japan only), 903C	0.0-2.3	0.0-0.6	2.3-4.5	0.6-1.2	4.5-6.8	1.2-1.8
906K ¹	0.0-4.2	0.0-1.1	4.2-8.3	1.1-2.2	8.3-12.1	2.2-3.2
906M ²	0.0-4.2	0.0-1.1	4.2-7.9	1.1-2.1	7.9-12.1	2.1-3.2
907K ¹	0.0-4.2	0.0-1.1	4.2-8.3	1.1-2.2	8.3-12.1	2.2-3.2
907M ²	0.0-4.2	0.0-1.1	4.2-7.9	1.1-2.1	7.9-12.1	2.1-3.2
908K ¹	0.0-4.2	0.0-1.1	4.2-8.3	1.1-2.2	8.3-12.1	2.2-3.2
908M ²	0.0-4.2	0.0-1.1	4.2-7.9	1.1-2.1	7.9-12.1	2.1-3.2
910K, 914K ³	7.0-10.1	1.9-2.7	10.1-13.1	2.7-3.5	13.1-16.1	3.5-4.3
926M	3.3-5.6	0.9-1.5	5.2-8.5	1.4-2.2	8.1-11.2	2.1-3.0
930M	3.4-5.9	0.9-1.6	5.5-8.8	1.5-2.3	8.6-11.9	2.3-3.1
938M	3.4-5.9	0.9-1.6	5.6-8.9	1.5-2.4	8.6-11.9	2.3-3.1
950H ⁴	8.2-11.7	2.2-3.1	11.7-14.8	3.1-3.9	14.8-18.4	3.9-4.9
950K ⁴	7.5-10.7	2.0-2.8	10.7-13.3	2.8-3.5	13.3-16.7	3.5-4.4
950M ^{4,5,6}	7.3-10.3	1.9-2.7	10.3-12.4	2.7-3.3	12.4-14.9	3.3-3.9
962H, IT62H ⁴	7.8-12.0	2.1-3.2	12.0-15.1	3.2-4.0	15.1-18.5	4.0-4.9
962K ⁴	7.6-10.7	2.0-2.8	10.7-13.8	2.8-3.7	13.8-17.1	3.7-4.5
962M ^{4,5,6}	7.7-10.8	2.0-2.8	10.8-13.5	2.8-3.6	13.5-15.8	3.6-4.2
966H ⁴	9.0-13.2	2.4-3.5	13.2-16.8	3.5-4.4	16.8-20.6	4.4-5.4
966K ⁴	10.1-14.6	2.7-3.8	14.6-17.9	3.8-4.7	17.9-22.4	4.7-5.9
966M ^{4,5,6}	8.3-12.4	2.2-3.3	12.4-15.4	3.3-4.1	15.4-18.8	4.1-5.0
966M XE ^{4,5}	8.4-11.0	2.2-2.9	11.0-13.4	2.9-3.5	13.4-15.8	3.5-4.2
972H ⁴	11.3-17.0	3.0-4.5	17.0-20.7	4.5-5.5	20.7-24.7	5.5-6.5
972K ⁴	11.6-15.7	3.1-4.1	15.7-19.5	4.1-5.2	19.5-24.1	5.2-6.4
972M ^{4,5,6}	10.4-14.1	2.7-3.7	14.1-17.5	3.7-4.6	17.5-21.7	4.6-5.7
972M XE ^{4,5}	10.6-12.7	2.8-3.3	12.7-15.3	3.3-4.0	15.3-18.3	4.0-4.8
980H ⁴	14.9-21.0	3.9-5.5	21.0-26.4	5.5-7.0	26.4-32.5	7.0-8.6
980K ⁴	13.8-19.2	3.6-5.1	19.2-24.0	5.1-6.3	24.0-29.7	6.3-7.8
980M ^{4,5,6}	13.4-18.1	3.5-4.8	18.1-22.9	4.8-6.0	22.9-29.3	6.0-7.7
982M ^{4,5,6}	14.6-20.2	3.8-5.3	20.2-25.4	5.3-6.7	25.4-31.2	6.7-8.2
986H ⁴	19.0-27.3	5.0-7.2	27.3-35.8	7.2-9.5	35.8-44.3	9.5-11.7
988H ⁴	28.0-40.1	7.4-10.6	40.1-52.6	10.6-13.9	52.6-65.1	13.9-17.2
988K ⁴	23.8-34.1	6.3-9.0	34.1-44.7	9.0-11.8	44.7-55.3	11.8-14.6
990H ⁴	42.0-58.3	11.1-15.4	58.3-75.0	15.4-19.8	75.0-91.6	19.8-24.2
992K ⁴	53.0-75.7	14.0-20.0	75.7-98.4	20.0-26.0	98.4-121.0	26.0-32.0
993K ⁴	61.3-87.4	16.2-23.1	87.4-113.6	23.1-30.3	113.6-140.0	30.0-37.0
994H ⁴	87.0-123.0	23.0-32.5	123.0-160.0	32.5-42.4	160.0-197.0	42.4-52.0

¹ Meets Tier 4 Interim/Stage IIIA/Japan 2011 (Tier 4 Interim) or Tier 2/Stage II/Japan 2011 (Tier 2) equivalent emission standards.

² Meets Tier 4 Final/Stage IIIB/Japan 2014 (Tier 4 Final) or Tier 4 Interim/Stage IIIA/Japan 2011 (Tier 4 Interim) equivalent emission standards.

³ Meets Tier 4 Interim/Stage IIIB/Japan 2011 (Tier 4 Interim) equivalent emission standards.

⁴ The Medium Wheel Loader (i.e. 950 through 982) and Large Wheel Loader (i.e. 988 through 994) hourly fuel rates are taken directly from customer machines registered on Product Link worldwide. Data from the top and bottom 5% of these customer machines has been excluded from the tables because it varies widely (15-60% from the extremes shown) and therefore is not considered representative of what the remaining 90% of customers experience. Hourly fuel consumption for the 90% of machines in the tables also varies depending upon geographical region, load factor variation between units, etc. Cat machines are often used in more demanding applications which can account for differences between competitive models used in lighter duty applications. Consult your local Cat dealer for ways to more accurately estimate hourly fuel consumption for specific applications.

⁵ Machines that meet Tier 4 Final/Stage IV/Japan 2014 (Tier 4 Final) emission standards require the use of DEF with a consumption rate approximately 2-3% of diesel fuel.

⁶ These hourly fuel rates reflect the actual field population which includes a mix of machines operating with Economy Mode ON and machines operating with Economy Mode OFF. It has been demonstrated that operating in a typical application with Economy Mode ON can deliver 8% lower fuel consumption.

NOTE: Medium Wheel Loaders

Machines are not available in all regions. Contact your local Cat dealer for product availability.

Compact Wheel Loaders

Typical Application Description

(relative to work application)

- Low Light industrial or construction site duties. Moving light loads with bucket or pallet forks. Not continuous duty, considerable idle time. Machine could be working on average 2 hours or less per day.
- Medium Intermittent aggregate truck loading from stockpile, hopper charging or load and carry on firm, smooth surfaces for short distances with minimal grades. Free flowing, low density materials. Light utility, industrial and construction applications. Light snowplowing.
- High Continuous truck loading from stockpile and hopper charging. Loading from bank or load and carry on normal surfaces with low to medium rolling resistance and slight adverse grades. Low to medium density materials in properly sized bucket. Assumes normal travel distances associated with high productivity stockpile load-out and batch plant applications.

Load Factor Guide

(percent of available horsepower required for each work application)

- Low 0%-25%
- Medium 25%-50%
- High 50%-75%

Small, Medium and Large Wheel Loaders and Integrated Toolcarriers

Typical Application Description

(relative to work application)

- Low Intermittent aggregate truck loading from stockpile, hopper charging or load and carry on firm, smooth surfaces for short distances with minimal grades. Free flowing, low density materials. Light utility, industrial and construction applications. Light snowplowing. Most logging applications where there is considerable idling.
- Medium Continuous truck loading from stockpile and hopper charging. Loading from bank or load and carry on normal surfaces with low to medium rolling resistance and slight adverse grades. Low to medium density materials in properly sized bucket. Assumes normal travel distances associated with high productivity stockpile load-out and batch plant applications.
- High Loading shot rock (large loaders) from a face. Steady loading from very tight banks. Continuous work on rough or very soft surfaces with high rolling resistance. Load and carry in hard digging material with longer travel distances on poor surfaces with adverse grades. Handling high density materials with counterweighted machine.

Small and Medium Wheel Loader and Integrated Toolcarrier

Load Factor Guide

(average engine load factor based on application description for each range)

Fuel rates can vary for a specific load factor depending on model and application, therefore some overlap is shown in the load factor table.

- Low 15%-30%
- Medium 25%-35%
- High 30%-45%

Large Wheel Loaders

Load Factor Guide

(average engine load factor based on application description for each range)

- Low 35%-50%
- Medium 50%-65%
- High 65%-80%

- ⑨ Planned Maintenance Costs
 - Lube Oils, Filters, Grease, Labor

9

**PLANNED MAINTENANCE (PM)
LUBE OILS, FILTERS, GREASE, LABOR**

Planned Maintenance (PM) costs should be developed by the Cat dealer, with customer input for the specific application.

PM costs include the parts and labor at the intervals specified in the Operation and Maintenance Manuals provided for each machine. PM costs for each machine may vary slightly depending upon factors required or specified by the customer. See your local Cat dealer to develop the specific PM cost per hour estimate for your machine and application.

10a TIRES

(Line Item 10a)

Tire costs are an important part of the hourly cost of any wheel machine. Tire costs are also one of the most difficult to predict with many variables. The best estimate for tire costs are obtained when tire life estimates are based upon actual customer experience, and are used with prices the machine owner actually pays for the replacement tires.

For cases in which tire experience is not available, use the following tire life estimator curves.

Tire Life Estimators

- Curves do not allow for additional life from recapping. They assume new tires run to destruction, but this is not necessarily recommended.
- Based on standard machine tires. Optional tires will shift these curves either up or down.
- Sudden failure (blow out) due to exceeding Ton-MPH (tkm/h) limitations is not considered. Nor are premature failures due to puncture.
- Application Descriptions/Zones:

Low/Zone A: almost all tires actually wear through the tread from abrasion.

Medium/Zone B: tires wear out normally but others fail prematurely due to rock cuts, impacts and non-repairable punctures.

High/Zone C: few, if any, tires wear through the tread due to non-repairable damages, usually from rock cuts, impacts and continuous overloading.

NOTE: Tire life can often be increased by using extra tread and extra deep tread tires.

NOTE: Premature failure could occur at any time due to puncture.

MOTOR GRADERS

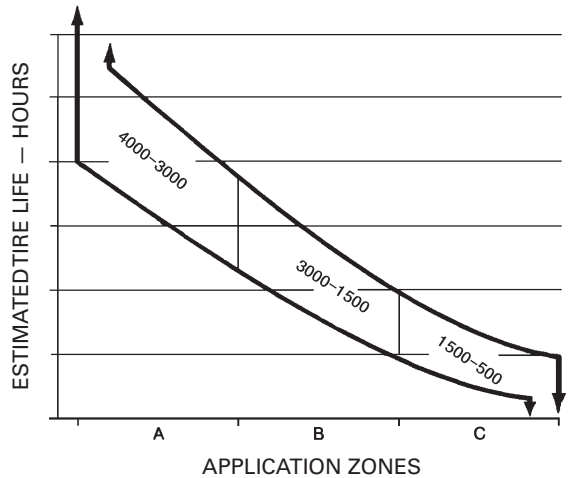

SKIDDERS

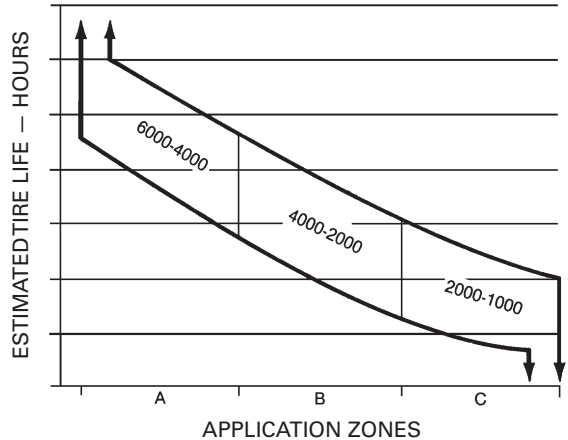

SKID STEER LOADERS

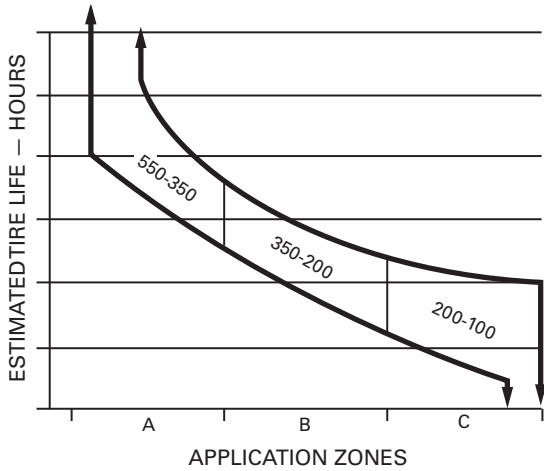

LOAD HAUL DUMP UNITS

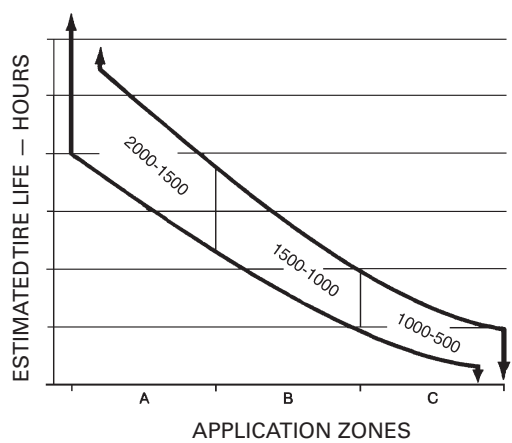

WHEEL TRACTOR-SCRAPERS

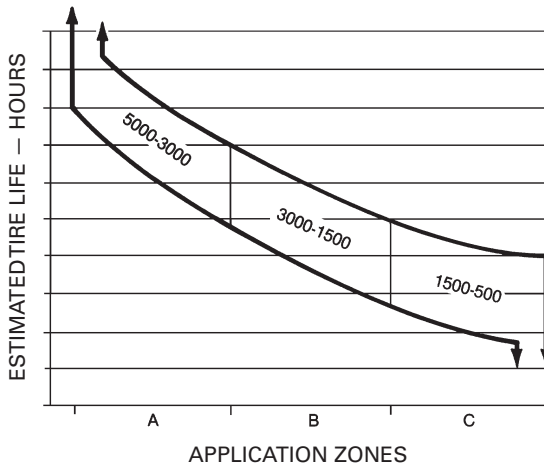

MINING & OFF-HIGHWAY TRUCKS

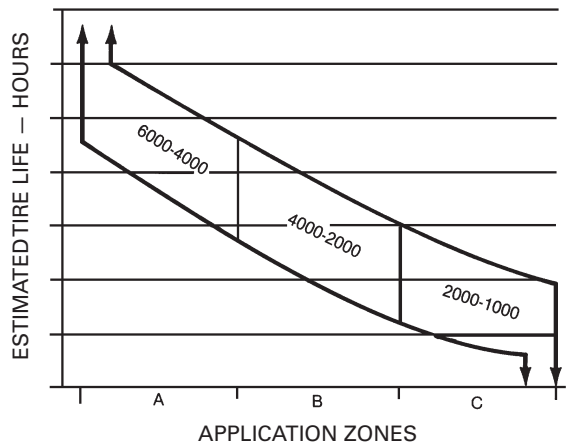

Key:

- Zone A – Almost all tires actually wear through the tread due to abrasion.
- Zone B – Some tires wear out normally while others fail prematurely due to rock cuts, impacts and non-repairable punctures.
- Zone C – Few, if any, tires wear through the tread because of non-repairable damages, usually from rock cuts, impacts or continuous overloading.

UNDERGROUND TRUCKS

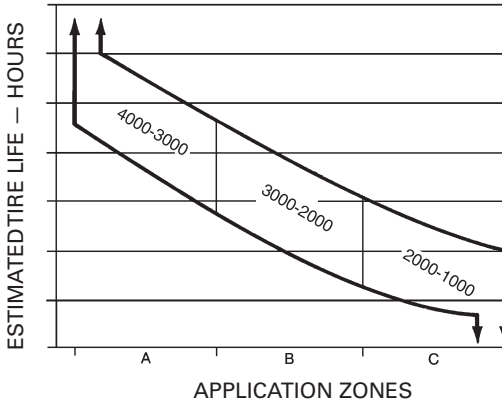

TRACTORS/WAGONS

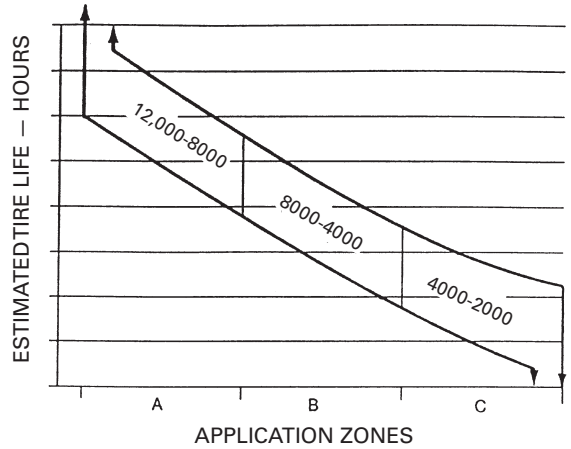

ARTICULATED TRUCKS

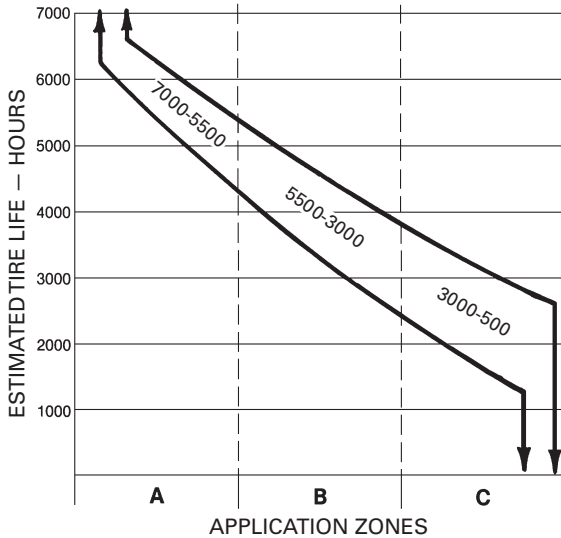

**WHEEL TRACTORS
WHEEL LOADERS**

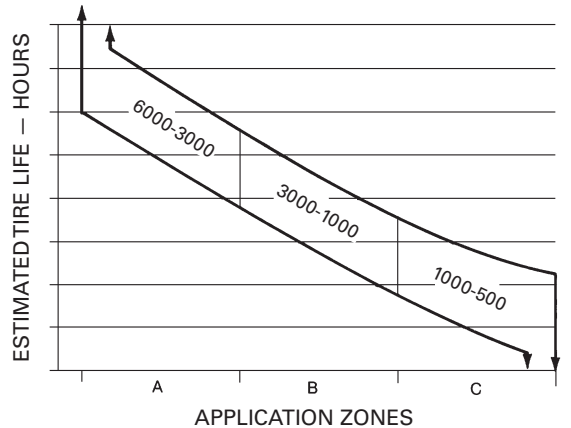

Key:

- Zone A – Almost all tires actually wear through the tread due to abrasion.
- Zone B – Some tires wear out normally, others fail prematurely due to rock cuts, impacts, and non-repairable punctures.
- Zone C – Few, if any, tires wear through the tread because of non-repairable damages, usually from rock cuts, impacts, or continuous overloading.

Application Tire Life	Tires Cost Per Hour – Basic Factors		
	Zone A 8000-5000	Zone B 5000-2500	Zone C 2500-500
Model 990 II 992G 994D	\$20-\$40	\$30-\$80	\$60-\$400

GOODYEAR LIFE ESTIMATING SYSTEM

As an additional assist in estimating *hauling unit* tire life, Goodyear Tire and Rubber Co. has furnished the following information which is included here with their permission. **READ THE PREAMBLE CAREFULLY.**

“... at present, there is no completely accurate, fool-proof method of forecasting tire life. Tire engineers have many theoretical methods ... but these generally are so involved and time consuming that they are impractical for field use.

“However, the tire industry has made many surveys of tire performance and arrived at a system which can give rough *estimates* of tire life. Studies done by the major tire companies and by at least two major equipment manufacturers are in close agreement.

“The table [which follows] shows how to apply this system ...”

ESTIMATED TIRE SERVICE LIFE OF HAULING UNITS (Trucks and Scrapers)

No.	Condition	Factor
I	Maintenance	
	Excellent	1.090
	Average	0.981
	Poor	0.763
II	Speeds (Maximum)	
	16 km/h ~ 10 mph	1.090
	32 km/h ~ 20 mph	0.872
	48 km/h ~ 30 mph	0.763
III	Surface Conditions	
	Soft Earth — No Rock	1.090
	Soft Earth — Some Rock	0.981
	Well Maintained — Gravel Road	0.981
	Poorly Maintained — Gravel Road	0.763
	Blasted — Sharp Rock	0.654
IV	Wheel Positions	
	Trailing	1.090
	Front	0.981
	Driver (Rear Dump)	0.872
	(Bottom Dump)	0.763
	(Self Propelled Scraper)	0.654

No.	Condition	Factor
V	Loads (See No. VIII note)	
	T&RA/ETRTO* Recommended Loading	1.090
	20% Overload	0.872
	40% Overload	0.545
VI	Curves	
	None	1.090
	Medium	0.981
	Severe	0.872
VII	Grades (Drive Tires Only)	
	Level	1.090
	5% Max.	0.981
	15% Max.	0.763
VIII	Other Miscellaneous Combinations (See note below)	
	None	1.090
	Medium	0.981
	Severe	0.872
	Condition VIII is to be used when overloading is present in combination with one or more of the primary conditions of maintenance, speeds, surface conditions and curves. The combination of severe levels in these conditions, together with an overload, will create a new and more serious condition which will contribute to early tire failure to a larger extent than will the individual factors of each condition.	

*Tire and Rim Association/European Tire and Rim Technical Organization.

Base Average Life

Type of Tire	Hours	km	Miles
E-3 Std. Bias Tread	2510	40 400	25,100
E-4 Bias Xtra Tread	3510	56 500	35,100
E-4 Radial Xtra Tread	4200	67 600	42,000

Using Base Hours (or Miles), multiply by the appropriate factor for *each* condition to obtain approximate estimated hours (or miles) as the final product.

Example: An off-highway truck equipped with E-4 drive tires running on a well maintained haul road having easy curves and minimum grades and receiving “average” tire maintenance attention but being 20% overloaded:

Condition: I II III IV V VI VII VIII
 Factor: 0.981 × 0.872 × 0.981 × 0.872 × 0.872 × 0.981 × 0.981 × 0.981
 × 3510 base hours = 2114 hours (say 2100 hours)

As can be seen, this system requires the careful application of strictly subjective judgments, and can be expected to result in conservative estimates. Keep in mind, however, **that the system is offered only as an aid in estimating and not as a rigid set of rules.**

On the other hand, if tire life on a given job is considered less than satisfactory, an analysis of these factors may point to conditions which can be improved to the betterment of tire life.

Replacement tire prices should always be obtained from local tire company sources.

Since tires are considered a wear item in this method of estimating owning and operating costs, total tire replacement cost is deducted from machine delivered price to arrive at a net figure for depreciation purposes. Outlay for tires is then included as an item in operating costs:

$$\text{Hourly Tire Cost} = \frac{\text{Replacement Cost of Tires}}{\text{Estimating Tire Life in Hours}}$$

Recapping can sometimes lower hourly tire cost. Considerations are availability of molds, local recapping costs, and experience with recap life.

10b

UNDERCARRIAGE

(Line Item 10b)

Undercarriage expense can be a major portion of the operating costs for track-type machines, and these costs can vary *independently* of basic machine costs. That is, the undercarriage can be employed in an extremely abrasive, high-wear environment while the basic machine may be in an essentially easy application, and vice-versa. For that reason, it is recommended that the hourly cost of undercarriage be calculated separately as a wear item rather than being included in the repair costs for the basic machine.

Three primary conditions affect probable life-expectancy of track-type undercarriage:

- 1. Impact.** The most measurable effect of impact is structural – that is bending, chipping, cracking, spalling, roll-over, etc., and problems with hardware and pin and bushing retention.

Impact ratings:

High – Non-penetrable hard surfaces with 150 mm (6") or higher bumps.

Moderate – Partially penetrable surfaces and bumps of 75-150 mm (3-6") height.

Low – Completely penetrable surfaces (which provide full shoe plate support) with few bumps.

- 2. Abrasiveness.** The tendency of the underfoot materials to grind away the wear surfaces of track components.

Abrasiveness ratings:

High – Saturated wet soils containing a high proportion of hard, angular or sharp sand or rock particles.

Moderate – Slightly or intermittently damp soils containing a low proportion of hard, angular or sharp particles.

Low – Dry soils or rock containing a low proportion of hard, angular or sharp sand or rock chip particles.

Impact and abrasiveness in combination can accelerate wear rates beyond their individual effects when considered alone, thus further reducing component life. This should be taken into account in determining impact and abrasiveness ratings or, if preferred, the combination can be included in selecting the “Z” factor.

- 3. “Z” factor.** Represents the combined effect on component life of the many intangible environmental, operational and maintenance considerations on a given job.

Environment and Terrain. Earth which may not be abrasive itself can pack in sprocket teeth, causing mis-match and high stress as the teeth engage the bushings. Corrosive chemicals in the materials being moved or in the natural soil can affect wear rates, while moisture and temperature can exaggerate the effect. Temperature alone can play its own role – hot slag and hard-frozen soils being but the extremes. Constant sidehill work can increase wear on the sides of components.

Operation. Some operator practices tend to increase track wear and cost if not controlled on the job. Such practices include high-speed operation, particularly in reverse; tight turns or constant corrections in direction; and stalling the tractor under load forcing the tracks to slip.

Maintenance. Good maintenance – proper track tension, daily cleaning when working in sticky materials, etc. – combined with periodic wear measurement and timely attention to recommended services (CTS) can extend component life and lower costs by minimizing the effects of these and other adverse conditions.

While impact and abrasion should not be too difficult to judge, selection of the proper “Z” factor will require careful analysis of job conditions such as weather, tendency for soil packing, side-hill loading, corrosive environment, etc.; operational factors such as high-speed reverse, amount of travel, tight turns, track slippage under overload, etc.; and maintenance considerations such as proper tensioning, use of Custom Track Service, etc.

Selection of the “Z” multiplier is strictly a matter of judgement and common sense, but its effect on cost can be the difference between profit on a controlled job and heavy loss where control is allowed to slip. To assist in arriving at an appropriate value for the “Z” factor, consider that proper maintenance – or the lack thereof – will represent about 50% of its effect, environment and terrain 30%, and operator practices 20%. For large excavators the amount of travel is the critical part of the “Z” factor. A good operator working under good field conditions can be counterbalanced by poor maintenance practices to yield a fairly high “Z” factor. On the other hand, close attention to maintenance, tension and alignment can more than offset a bad underfoot condition resulting in severe sprocket packing, and lead to selection of a moderate to low “Z” factor. Obviously, flexibility in selection of a “Z” factor has been built into the system, and use of this flexibility is encouraged. Further, a considerable measure of control can be maintained over the “Z” factor, and any reduction of its effects is money in the bank. Your Cat dealer CTS man can be invaluable in this endeavor as well as helping you establish a comprehensive undercarriage cost control program.

Estimating Undercarriage Cost

The guide below gives a basic factor for the various track-type machines and a series of conditions multipliers to modify the basic cost according to the anticipated impact, abrasive and miscellaneous (“Z”) conditions under which the unit will be operating.

- Step 1. Select machine and its corresponding basic factor.
- Step 2. Determine range for impact, abrasiveness and “Z” conditions.
- Step 3. Add selected conditions multipliers and apply sum to basic factor.

The result will be the estimated hourly cost for undercarriage in that application.

Undercarriage Basic Factors			
Model	Basic Factor		
5230B	28.2		
D11T	26.1		
5130B	20.4		
D10T2	16.2		
5110B	13.6		
D9T	10.9		
D8T	9.6		
973D, 587T, 589, D7R LGP, D7E LGP	11.2		
D7R, 963D, 583T, D6T LGP, D7R XR, D7E	9.1		
385C, 5090B	7.2		
D6T, 953D, 572R, 527	7.0		
365C Tier 2	6.8		
345D	5.9		
D6N XL, 517	5.6		
336D	5.0		
D3K (All), D4K (All), D5K (All), 939C, PL61	4.1		
329D	3.9		
314D, 315D, 319D, 323D	3.4		
320D	2.9		
307D, 308D, 311D, 312D	2.4		
Conditions Multipliers			
	Impact	Abrasiveness	“Z”
High	0.3	1.0	1.0
Moderate	0.2	0.5	0.5
Low	0.1	0.1	0.2

Example: D10T2 in high impact, non-abrasive material with a moderate “Z” factor.

$$\begin{aligned}
 \text{D10T2 Basic Factor} &= 16.2 \\
 \text{Multipliers:} & \quad \text{I} = 0.3 \\
 & \quad \text{A} = 0.1 \\
 & \quad \text{Z} = 0.5
 \end{aligned}$$

$$\text{U.C. cost} = 16.2 (0.3 + 0.1 + 0.5) = \mathbf{\$14.58/hour}$$

- NOTE:**
1. Conditions Multipliers may be selected in any combination. Thus, a multiplier of 0.4 (all low-range multipliers) represents the best of the best, while 1.7 (all high range multipliers) would be the worst of the worst conditions.
 2. The hourly undercarriage cost estimate resulting from this method will be made up of *approximately* 70% parts cost and 30% labor charges. The cost of undercarriage components is based on published U.S. Consumers List Prices and may be adjusted as needed for import duties, exchange rates, etc. outside the United States. Labor has been figured at \$60.00 (U.S.) per shop hour.
 3. For further information and guidance, refer to the current issue of the Caterpillar Custom Track Service Handbook.
 4. This formula for estimating undercarriage cost should not be used for tractors working in stockpile coal handling applications. Undercarriage costs are nominal in stockpile coal handling, and using this formula will result in estimating cost substantially above actual costs.

11

REPAIR COSTS

(Line Item 11)

Repair cost per hour should be developed by the Cat dealer, with customer input for the specific machine application and requirements.

As with PM cost per hour, repair costs are significantly affected by the specific application and situation. Several important variables must be provided by the customer and the local Cat dealer. This will enable a calculated cost per hour that is specific to the machine conditions and customer needs.

Machine applications, operating conditions, ownership periods, component life, and maintenance attention determine repair costs. In any specific application, actual cost experience on similar machines and applications provides the best basis for establishing the hourly repair cost.

Repairs and component lives are normally the largest single item in operating costs and include all parts and direct labor (except operator's wages) chargeable to the machine. Shop overhead can be absorbed in general overhead or charged to machines as a percent of direct labor cost, whichever is the owner's normal practice.

Hourly repair costs for a single machine normally follow an upward stairstep pattern since major outlays for repairs usually come in spurts. However, when broad averages are considered, the stairstep becomes a smooth, upward curve. Since this hourly repair cost curve starts low and gradually rises over time, hourly operating costs must be adjusted upward as the unit ages. Alternatively an average repair cost can be used which provides a straight line graph. Most owners prefer the average method, and it is the one suggested here.

Since repair costs are low initially and rise gradually, averaging them produces extra funds at first which are reserved to cover future higher costs.

Your Cat dealer has the ability to make more accurate repair cost estimates and we suggest you use their experience and expertise if you need help in estimating operating costs.

As stated, repair costs are affected by application, operating conditions, ownership period, maintenance, and age of the equipment. The most significant effects on cost will be those factors affecting major component life. A second significant factor is whether the repair is performed before or after catastrophic failure. Repair before a major component fails can be one-third of an after failure repair with only a moderate sacrifice in life (see graphs). Oil analysis and other diagnostic tools, maintenance inspections and indicators, and operator notes are vital to determine the optimum repair point and thereby achieving lower hourly repair costs. Maintenance practices are significant because they affect component longevity and the percentage of scheduled, before failure repairs.

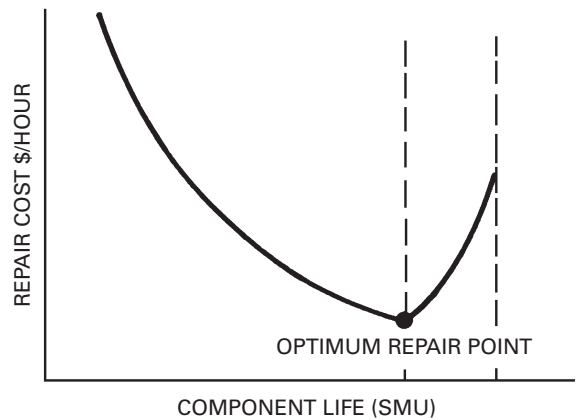
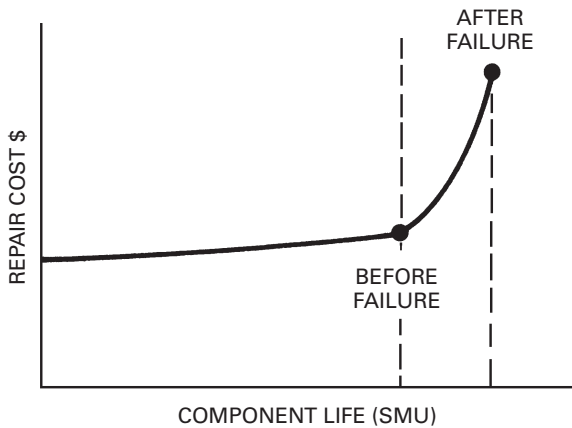

Owning & Operating Costs

- ⑫ Special Wear Items
 - ⑮ Operator's Hourly Wage
- ### Owning & Operating Examples
- Track-Type Tractor

12

SPECIAL WEAR ITEMS

(Line Item 12 and Subsection 12A)

All costs for high-wear items such as cutting edges, ripper tips, bucket teeth, body liners, router bits, etc., and welding costs on booms and sticks should be included here. These costs will vary widely depending on applications, materials and operating techniques. Consult your Cat dealer Parts Department for estimated life under your job conditions.

15

OPERATOR'S HOURLY WAGE

(Line Item 15)

This item should be based on local wage scales and should include the hourly cost of fringe benefits.

EXAMPLES OF FIGURING OWNING AND OPERATING COSTS

(The following two examples are for illustrative purposes only. The intent is to show how the worksheets could be filled out. The PM and Repair costs should be developed by your local Cat dealer.)

Example I: ESTIMATING HOURLY OWNING AND OPERATING COSTS OF A TRACK-TYPE TRACTOR

Assume a power shift track-type tractor with straight bulldozer, hydraulic control, tilt cylinder and three-shank ripper, is purchased by a contractor for \$135,000, delivered price at job site.

Application will be production dozing of bank gravel. Minimal ripping will be required to loosen material.

In the following calculations, refer as necessary to the source material already reviewed.

OWNING COSTS —

To Determine Residual Value at Replacement

Enter delivered price, \$135,000, in space (A). (See example form at end of this discussion.) Since the machine being considered is a track-type tractor, no tires are involved. This particular owner's experience is that at trade-in time, the tractor will be worth approximately 35% of its original value. This \$47,250 trade-in value is entered in space (B) leaving a net of \$87,750 to be recovered through work.

Enter the net value to be recovered through work in space (C).

Indicated ownership period is 7 years with annual usage of 1200 hours per year or 8400 hours of total ownership usage.

Divide the Net Value from space (C), \$87,750, by Ownership Usage, 8400 hours, and enter result \$10.45 in space (D).

Interest, Insurance, Taxes

In this example, local rates are assumed as follows:

Interest	16%
Insurance	1%
Taxes	1%
	18%

Using the following formula:

$N = 7:$

$$\left[\frac{135,000 (7 + 1) + 47,250 (7 - 1)}{2 \times 7} \right] \times 0.16 = 12.99$$

Enter \$12.99 in space (E).

Insurance and property taxes can also be calculated using the same formula as shown for the interest cost, and entering them on lines 5 and 6.

Items 3b, 4, 5 and 6 can now be added and the result, \$25.06 entered in space (H) Total Hourly Owning Costs.

OPERATING COSTS —

Fuel

See fuel consumption tables. The intended application, production dozing, indicates a medium load factor. Assume that the estimated fuel consumption from the table is 17 liter/hr (4.5 U.S. gal/hr.). Cost of fuel in this locality is \$0.34/liter (\$1.25/U.S. gal.).

Consumption	Unit Cost	Total
17 liter/hr	× \$0.34 liter	= \$5.78
4.5 gal/hr	× \$1.25 gal.	= \$5.63

Enter this figure in space (I).

Planned Maintenance (PM) Cost per Hour

Use PM cost per hour estimate developed by your local Cat dealer. (For this example assume cost per hour is \$2.30) Enter this figure in space (J) on line 9.

Tires

Since this example considers a track-type tractor, space (K) is left blank.

Undercarriage

Our estimating reference gives an undercarriage cost Basic Factor of 6.6 for this tractor. It is anticipated that with some ripping on the job, impact loading of track components will be medium, indicating an “I” multiplier of 0.2. The gravel-sand mix in the bank, being dry, should be only moderately abrasive for an “A” multiplier of 0.2. In analyzing the miscellaneous conditions: there is enough clay in the bank to produce some packing of the sprockets; the operator is careful, but is forced into some tight turns because of space limitations; there is good drainage in the pit; track tension is checked weekly; and all track-type equipment on the job is enrolled in the Custom Track Service program. Accordingly, the “Z” multiplier is judged to be somewhat greater than low level — 0.3 in this case.

It should be noted that in applying particularly the “Z” factor, rather wide flexibility is provided and was used in the above example. Such flexibility is intended and its use encouraged.

Then:

$$\text{Cost per hour} = \text{Basic Factor} \times (\text{I} + \text{A} + \text{Z})$$

$$\text{Basic Factor} = 6.6$$

$$\text{Conditions Multipliers: I} = 0.2$$

$$\text{A} = 0.2$$

$$\text{Z} = 0.3$$

$$\text{Cost per hour } 6.6 (0.2 + 0.2 + 0.3) = \$4.62 \text{ which is entered in space (L).}$$

Repair Cost per Hour

Use the Repair cost per hour estimate developed by your local Cat dealer. (For this example assume cost per hour is \$6.12) Enter this figure in space (M) on line 11.

Special Items

Assuming the tractor is equipped with a three-shank ripper and an “S” dozer, allowance must be made for ripper tips, shank protectors, and dozer cutting edges.

Assume your knowledge of the operation indicates the ripper will be used only about 20% of total tractor operating time. Estimated tip life while in use is 30 hours. Therefore, tips will be replaced:

$$\frac{30 \text{ Hours}}{0.20} = \text{each 150 hours of tractor operation}$$

Shank protector life is estimated at three times tip life or 450 hours of tractor operation.

Cutting edge life is estimated to be 500 hours.

Using local prices for these items, hourly costs are estimated as follows:

$$\text{Tips: } \frac{3 @ \$35.00 \text{ ea.}}{150 \text{ hr.}} = \$0.70 \text{ per hour}$$

$$\text{Shank Protectors: } \frac{3 @ \$55.00 \text{ ea.}}{450 \text{ hr.}} = \$0.37 \text{ per hour}$$

$$\text{Cutting Edges: } \frac{\$125 \text{ per set}}{500 \text{ hr.}} = \$0.25 \text{ per hour}$$

The total of these, \$1.32; is entered in space (N).

Items 8, 9, 10b, 11 and 12 can now be added and the result, \$19.99, is entered in space (O), Total Hourly Operating Costs.

Operator’s Hourly Wage

Assume this is \$25.00 including fringe benefits. This figure is entered in space (P).

Total Owning Costs, Total Operating Costs and Operator’s Hourly Wage are now added together and the result, \$67.01, is entered in space (Q). The itemized estimate of Hourly Owning and Operating Costs is now complete.

Example II: ESTIMATING HOURLY OWNING AND OPERATING COSTS OF A WHEELED VEHICLE

With only a few simple changes, owning and operating costs for a wheeled vehicle are calculated using the same format as that used for the Track-Type Tractor. Only the differences will be explained as we look at example calculations for a wheel loader.

OWNING COSTS —**To Determine Residual Value at Replacement**

Enter delivered price in space (A). The cost of tires is deducted since they will be treated as a wear item. For purposes of illustration, the Wheel Loader is estimated to have a potential 48% trade-in value (B) at the end of the 5 year/7500 hour ownership usage, leaving a net value to be recovered through work of \$34,320 (C).

Interest, Insurance, Taxes

Refer to the formulas using the same rates as before and 1500 operating hours per year. The result \$4.22 is applied to the interest cost (E).

Insurance and property taxes can also be calculated using the same formula as shown for the interest cost.

The sum of lines 3b, 4, 5 and 6 gives the total hourly owning cost, line 7.

OPERATING COSTS —**Fuel**

See the fuel consumption tables and apply the actual cost of purchasing fuel in the project area (I).

Planned Maintenance (PM) Cost per Hour

Use PM cost per hour estimate developed by your local Cat dealer. (For this example assume cost per hour is \$2.10.) Enter this figure in space (J) on line 9.

Tires

Use the tire replacement cost and the best estimate of tire life based on experience and anticipated job conditions.

Repair Cost per Hour

Use the Repair cost per hour estimate developed by your local Cat dealer. (For this example assume cost per hour is \$3.39.) Enter this figure in space (M) on line 11.

Special Items

Ground engaging tools, welding, etc. are covered here. Use current costs for cutting edges and similar items. Use your best estimate of the hours of life which can be expected from them based on previous experience in like materials. Enter the total on line 12.

The total of lines 8 through 13 represents hourly operating costs.

Operator's Hourly Wage

To give a true picture of operator cost, include fringe benefits as well as direct hourly wages (line 15).

TOTAL O&O

The total of lines 7, 13 and 15 is the total hourly owning and operating cost of the machine. Keep in mind that this is an estimate and can change radically from project to project. For the greatest accuracy, the hourly cost reflected in actual on-the-job cost records should be used.

HOURLY OWNING AND OPERATING COST ESTIMATE

DATE _____

	Estimate #1	Estimate #2
	Track-type Tractor	Wheel Loader
A–Machine Designation		
B–Estimated Ownership Period (Years)	7	5
C–Estimated Usage (Hours/Year)	1200	1500
D–Ownership Usage (Total Hours)(B × C).	8400	7500

OWNING COSTS

1. a. Delivered Price (P), to the Customer (including attachments) . .	(1) 135,000 (A)	(2) 70,000
b. Less Tire Replacement Cost if desired	N/A	4000
c. Delivered Price Less Tires.	135,000	66,000
2. Less Residual Value at Replacement (S) (35%)	47,250 (B)	(48%) 31,680
(See subsection 2A on back)		
3. a. Net Value to be recovered through work	87,750 (C)	34,320
(line 1c less line 2)		
b. Cost Per Hour:		
Net Value (1) 87,750 (2) 34,320	10.45 (D)	4.58
Total Hours 8400 7500		
4. Interest Costs $\frac{P(N + 1) + S(N - 1)}{2N} \times \text{Simple Int. \% Rate}$		
N = No. Yrs. Hours/Year =		
(1) $\frac{[135,000(7 + 1)] + [47,250(7 - 1)]}{2 \times 7} \times 0.16$	(2) $\frac{[66,000(5 + 1)] + [31,680(5 - 1)]}{2 \times 5} \times 0.16$	
1200 Hours/Yr. =	1500 Hours/Yr. =	
	12.99 (E)	5.58
5. Insurance $\frac{P(N + 1) + S(N - 1)}{2N} \times \text{Insurance \% Rate}$		
N = No. Yrs. Hours/Year =		
(1) $\frac{[135,000(7 + 1)] + [47,250(7 - 1)]}{2 \times 7} \times 0.01$	(2) $\frac{[66,000(5 + 1)] + [31,680(5 - 1)]}{2 \times 5} \times 0.01$	
1200 Hours/Yr. =	1500 Hours/Yr. =	
	0.81 (F)	0.35

(Optional method when Insurance cost per year is known)

Ins. \$ _____ PerYr. ÷ _____ Hours/Yr. =

Estimating form continues next page

Estimate #1 Estimate #2

<p>6. Property Tax $\frac{P(N + 1) + S(N - 1)}{2N} \times \text{Tax Rate \%}$ N = No. Yrs. $\frac{\text{Hours/Year}}{\text{Hours/Year}} =$</p> <p>(1) $\frac{[135,000 (7 + 1)] + [47,250 (7 - 1)]}{2 \times 7} \times 0.01$ $\frac{\text{1200 Hours/Yr.}}{\text{1200 Hours/Yr.}} =$</p> <p>(2) $\frac{[66,000 (5 + 1)] + [31,680 (5 - 1)]}{2 \times 5} \times 0.01$ $\frac{\text{1500 Hours/Yr.}}{\text{1500 Hours/Yr.}} =$</p>	<p>0.81 (G)</p> <hr style="width: 100%;"/>	<p>0.35</p> <hr style="width: 100%;"/>
--	--	--

(Optional method when Property Tax cost per year is known)

Property Tax \$ _____ Per Yr. ÷ _____ Hours/Yr. =

<p>7. TOTAL HOURLY OWNING COST (add lines 3b, 4, 5 and 6)</p>	<p>25.06 (H)</p> <hr style="width: 100%;"/>	<p>10.86</p> <hr style="width: 100%;"/>
--	---	---

OPERATING COSTS

<p>8. Fuel: Unit Price × Consumption</p> <p>(1) $\frac{1.25}{1.25} \times \frac{4.50}{2} =$</p> <p>(2) $\frac{1.25}{1.25} \times \frac{2}{2} =$</p>	<p>5.63 (I)</p> <hr style="width: 100%;"/>	<p>2.50</p> <hr style="width: 100%;"/>
--	--	--

<p>9. Planned Maintenance (PM)-Lube Oils, Filters, Grease, Labor: (contact your local Cat dealer)</p>	<p>2.30 (J)</p> <hr style="width: 100%;"/>	<p>2.10</p> <hr style="width: 100%;"/>
--	--	--

<p>10. a. Tires: Replacement Cost ÷ Life in Hours</p> <p>Cost (1) $\frac{\text{N/A}}{\text{Life}}$ (2) $\frac{4000}{3500}$</p>	<p>(K)</p> <hr style="width: 100%;"/>	<p>1.14</p> <hr style="width: 100%;"/>
--	---------------------------------------	--

b. Undercarriage
 (Impact + Abrasiveness + Z Factor) × Basic Factor

(1) $(\frac{0.2}{0.2} + \frac{0.2}{0.2} + \frac{0.3}{0.3}) = \frac{0.7}{0.7} \times \frac{6.6}{6.6} =$

(2) $(\frac{\text{ }}{\text{ }} + \frac{\text{ }}{\text{ }} + \frac{\text{ }}{\text{ }}) = \frac{\text{ }}{\text{(Total)}} \times \frac{\text{ }}{\text{(Factor)}} =$

<p>4.62 (L)</p> <hr style="width: 100%;"/>	
--	--

<p>11. Repair Cost (Per Hour) (contact your local Cat dealer)</p>	<p>6.12 (M)</p> <hr style="width: 100%;"/>	<p>3.39</p> <hr style="width: 100%;"/>
--	--	--

<p>12. Special Wear Items: Cost ÷ Life</p> <p>(See subsection 12A on back)</p>	<p>1.32 (N)</p> <hr style="width: 100%;"/>	<p>0.60</p> <hr style="width: 100%;"/>
--	--	--

<p>13. TOTAL OPERATING COSTS (add lines 8, 9, 10a (or 10b), 11 and 12)</p>	<p>19.99 (O)</p> <hr style="width: 100%;"/>	<p>9.73</p> <hr style="width: 100%;"/>
---	---	--

<p>14. MACHINE OWNING PLUS OPERATING (add lines 7 and 13)</p>	<p>45.05</p> <hr style="width: 100%;"/>	<p>20.59</p> <hr style="width: 100%;"/>
--	---	---

<p>15. OPERATOR'S HOURLY WAGE (include fringes)</p>	<p>25.00 (P)</p> <hr style="width: 100%;"/>	<p>25.00</p> <hr style="width: 100%;"/>
---	---	---

<p>16. TOTAL OWNING AND OPERATING COST</p>	<p>70.05(Q)</p> <hr style="width: 100%;"/>	<p>45.59</p> <hr style="width: 100%;"/>
--	--	---

SUBSECTION 2A: Residual Value at Replacement

Gross Selling Price	(est. #1) (___%)	_____	(est. #2) (___%)	_____
Less: a. Commission		_____		_____
b. Make-ready costs		_____		_____
c. Inflation during ownership period*		_____		_____
Net Residual Value (Enter on line 2)		<u>47,250</u>	(<u>35</u> %)	<u>31,680</u> (<u>48</u> %) of original delivered price

*When used equipment auction prices are used to estimate residual value, the effect of inflation during the ownership period should be removed to show in constant value what part of the asset must be recovered through work.

**SUBSECTION 12A: Special Items
 (cutting edges, ground engaging tools, bucket teeth, etc.)**

(1)	Cost	Life	Cost/Hour	(2)
1.	<u>105</u>	÷ <u>150</u>	= <u>0.70</u>	1. <u>120</u> ÷ <u>200</u> = <u>0.60</u>
2.	<u>165</u>	÷ <u>450</u>	= <u>0.37</u>	2. _____ ÷ _____ = _____
3.	<u>125</u>	÷ <u>500</u>	= <u>0.25</u>	3. _____ ÷ _____ = _____
4.	_____	÷ _____	= _____	4. _____ ÷ _____ = _____
5.	_____	÷ _____	= _____	5. _____ ÷ _____ = _____
6.	_____	÷ _____	= _____	6. _____ ÷ _____ = _____
	Total	(1)	<u>1.32</u>	(2) <u>0.60</u>

(Enter total on line 12)

FORMER MODELS



TRACK-TYPE TRACTORS

Model	Product Ident. No. Prefix	Years Built	Horse-power FW/ Drawbar	Approx. Machine Weight kg (lb)	Gauge m (ft) and Width m (ft)	Length m (ft) and Height m (ft)	Transmission	Rated Drawbar Pull — kg (lb) and Forward Speed — km/h (mph)					
								1st	2nd	3rd	4th	5th	6th
D2	4U	47-58	43/38	3258 (7175)	1.02 (3'4") 1.42 (4'8")	2.74 (9'0") 1.57 (5'2")	DD	3609 (7950)	2588 (5700)	2061 (4540)	1634 (3600)	1067 (2350)	
D2	4U	47-58	42/35	3258 (7175)	1.02 (3'4") 1.57 (5'2")	2.74 (9'0") 1.57 (5'2")	DD	3609 (7950)	2588 (5700)	2061 (4540)	1634 (3600)	1067 (2350)	
D2	5U	57-58	38/32	3119 (5870)	1.27 (4'2") 1.42 (4'8")	2.74 (9'0") 1.57 (5'2")	DD	3033 (6680)	2483 (5420)	2007 (4420)	1703 (3570)	1035 (2280)	
D2	5U	57-58	43/38	3373 (7430)	1.27 (4'2") 1.67 (5'6")	2.74 (9'0") 1.57 (5'2")	DD	3609 (7950)	2588 (5700)	2061 (4540)	1634 (3600)	1067 (2250)	
D3	79U	72-79	62/—	4812 (10,610)	1.42 (4'8") 1.78 (5'10")	2.77 (9'1") 1.70 (5'7")	PS						
D3 LGP	6N	72-79	62/—	5410 (11,925)	1.65 (5'5") 2.29 (7'6")	2.97 (9'10") 1.70 (5'7")	PS	3.1 (1.9)	5.6 (3.5)	11.3 (7.0)			
D3B	23Y	79-87	65	6719 (14,812)	1.42 (4'8") 1.78 (5'10")	2.77 (9'1") 2.67 (8'9")	PS	3.1 (1.9)	5.6 (3.5)	11.4 (7.1)			
D3B	27Y	79-87	65	6877 (15,160)	1.42 (4'8") 1.78 (5'10")	2.77 (9'1") 2.67 (8'9")	PS	3.1 (1.9)	5.9 (3.7)	10.6 (6.6)			
D3B LGP	24Y	79-87	65	7479 (16,488)	1.65 (5'5") 2.29 (7'6")	2.99 (9'10") 2.67 (8'9")	PS	3.1 (1.9)	5.6 (3.5)	11.4 (7.1)			
D3B LGP	28Y	79-87	65	7637 (16,836)	1.65 (5'5") 2.29 (7'6")	2.99 (9'10") 2.67 (8'9")	PS	3.1 (1.9)	5.9 (3.7)	10.7 (6.7)			
D3B	3YC	85-87	65	6719 (14,812)	1.42 (4'8") 1.78 (5'10")	2.77 (9'1") 2.67 (8'9")	DD	5593 (12,330)	3993 (8802)	2694 (5940)	1830 (4034)	1326 (2925)	
D3B LGP	5MC	85-87	65	7479 (16,488)	1.65 (5'5") 2.29 (7'6")	2.99 (9'10") 2.67 (8'9")	DD	5595 (12,330)	3993 (8802)	2694 (5940)	1830 (4034)	1326 (2925)	

NOTE: Power Shift models show speeds only, not drawbar pull.
NOTE: Track-Type Tractor weights do not include blades until 1967.

Track-Type Tractors (cont'd)

Model	Product Ident. No. Prefix	Years Built	Horse-power FW/ Drawbar	Approx. Machine Weight kg (lb)	Gauge m (ft) and Width m (ft)	Length m (ft) and Height m (ft)	Transmission	Rated Drawbar Pull — kg (lb) and Forward Speed — km/h (mph)					
								1st	2nd	3rd	4th	5th	6th
D3C	5KG	87-90	67	7084 (15,618)	1.42 (4'8") 1.79 (5'10.6")	2.8 (9'4") 2.66 (8'8.9")	PS						
D3C Series II		90-93	70	7001 (15,435)	1.42 (4'8") 1.79 (5'11")		PS	3.1 (1.9)	5.9 (3.7)	10.8 (6.7)			
D3C Series III		93-01	70	7110 (15,650)	1.45 (4'9") 1.85 (6'1")	3.98 (13'1") 2.73 (8'11")	HYS		0-9.0 (0-5.6)				
D3C XL Series II		91-93	70	7242 (15,965)	1.42 (4'8") 1.83 (6'0")		PS	3.1 (1.9)	5.9 (3.7)	10.8 (6.7)			
D3C XL Series III		93-01	70	7304 (16,100)	1.45 (4'9") 1.85 (6'1")	3.98 (13'1") 2.73 (8'11")	HYS		0-9.0 (0-5.6)				
D3G XL	CFC	01-03	70	7314 (16,125)	1.45 (4'9") 1.85 (6'1")	4.02 (13'2") 2.72 (8'11")	HYS		0-9.0 (0-5.6)				
D3G XL*	JMH	03-07	70	7345 (16,193)	1.45 (4'9") 1.85 (6'1")	4.02 (13'2") 2.72 (8'11")	HYS		0-9.0 (0-5.6)				
D3C LGP	1PJ	87-90	67	7788 (17,170)	1.65 (5'4") 2.29 (7'6")	3.0 (9'10.1") 2.66 (8'8.9")	PS	3.1 (1.9)	5.9 (3.7)	10.8 (6.7)			
D3C LGP Series II		90-93	70	7788 (17,170)	1.65 (5'5") 2.29 (7'6")		PS	3.1 (1.9)	5.9 (3.7)	10.8 (6.7)			
D3C LGP Series III		93-01	70	7710 (17,000)	1.68 (5'6") 2.31 (7'7")	3.95 (13'0") 2.73 (8'11")	HYS		0-9.0 (0-5.6)				
D3G LGP	CFF	01-03	70	7723 (17,026)	1.68 (5'6") 2.31 (7'7")	4.02 (13'2") 2.72 (8'11")	HYS		0-9.0 (0-5.6)				
D3G LGP*	BYR	03-07	70	7768 (17,126)	1.68 (5'6") 2.31 (7'7")	4.02 (13'2") 2.72 (8'11")	HYS		0-9.0 (0-5.6)				

*Meets U.S. EPA Tier 2/EU Stage II/Japan 2001 (Tier 2) equivalent emission standards.

NOTE: Power Shift models show speeds only, not drawbar pull.

NOTE: Track-Type Tractor weights do not include blades until 1967.

Track-Type Tractors (cont'd)

Model	Product Ident. No. Prefix	Years Built	Horse-power FW/ Drawbar	Approx. Machine Weight kg (lb)	Gauge m (ft) and Width m (ft)	Length m (ft) and Height m (ft)	Transmission	Rated Drawbar Pull — kg (lb) and Forward Speed — km/h (mph)					
								1st	2nd	3rd	4th	5th	6th
								D4	6U	47-59	48/43	4629 (10,195)	1.12 (3'8") 1.58 (5'2")
D4	6U	47-59	60/48	4847 (10,675)	1.12 (3'8") 1.58 (5'2")	3.16 (10'5") 1.54 (5'1")	DD	4858 (10,700)	3496 (7700)	2724 (6000)	2093 (4610)	1326 (2920)	9.8 (6.1)
D4	6U	47-59	63/50	4844 (10,675)	1.12 (3'8") 1.58 (5'2")	3.18 (10'5") 1.76 (5'10")	DD	4858 (10,700)	3528 (7770)	2724 (6000)	2093 (4610)	1326 (2920)	9.8 (6.1)
D4	7U	47-59	63/50	5067 (10,970)	1.52 (5'0") 1.98 (6'6")	3.16 (10'5") 1.76 (5'10")	DD	4858 (10,700)	3528 (7770)	2724 (6000)	2093 (4610)	1326 (2920)	9.8 (6.1)
D4B	2XF	87	75	7450 (16,420)	1.42 (4'8") 1.78 (5'10")	2.78 (9'1") 2.67 (8'9")	PS						
D4B LGP	1SG	87	75	7800 (17,200)	1.65 (5'5") 2.29 (7'6")	2.99 (9'10") 2.67 (8'9")	PS						
D4C	39A	59-63	65/52	5064 (11,155)	1.12 (3'8") 1.58 (5'2")	3.05 (10'1") 1.76 (5'10")	DD	4858 (10,700)	3528 (7770)	2724 (6000)	2093 (4610)	1321 (2910)	9.8 (6.1)
D4C	40A	59-63	65/52	4881 (10,750)	1.52 (5'0") 1.98 (6'6")	3.05 (10'1") 1.76 (5'10")	DD	4858 (10,700)	3528 (7770)	2724 (6000)	2093 (4610)	1321 (2910)	9.8 (6.1)
D4C	1RJ	87-90	78	7581 (16,714)	1.42 (4'7") 1.83 (6'0")	3.00 (9'10.1") 2.66 (8'8.9")	PS						
D4C Series II		90-93	80	7557 (16,660)	1.42 (4'8") 1.83 (6'5")		PS						
D4C Series III		93-01	80	7330 (16,150)	1.50 (4'11") 1.91 (6'3")	3.99 (13'1") 2.73 (8'11")	HYS						
D4C XL Series III		93-01	80	7520 (16,570)	1.50 (4'11") 1.96 (6'5")	3.99 (13'1") 2.73 (8'11")	HYS						

NOTE: Power Shift models show speeds only, not drawbar pull.
NOTE: Track-Type Tractor weights do not include blades until 1967.

Track-Type Tractors (cont'd)

Model	Product Ident. No. Prefix	Years Built	Horse-power FW/ Drawbar	Approx. Machine Weight kg (lb)	Gauge m (ft) and Width m (ft)	Length m (ft) and Height m (ft)	Transmission	Rated Drawbar Pull — kg (lb) and Forward Speed — km/h (mph)						
								1st	2nd	3rd	4th	5th	6th	
D4C LGP	2CJ	87-90	78	7905 (17,427)	1.65 (5'4") 2.29 (7'6")	3.00 (9'10.1") 2.66 (8'8.9")	PS							
D4C LGP Series II		90-93	80	7905 (17,427)	1.65 (5'5") 2.29 (7'6")		PS	3.2 (2.0)	5.9 (3.7)	11.1 (6.9)				
D4C LGP Series III		93-01	80	7790 (17,160)	1.68 (5'6") 2.31 (7'6")	3.99 (13'1") 2.73 (8'11")	HYS		0-9.0 (0-5.6)					
D4D	78A	63-68	65/52	5900 (13,000)	1.52 (5'0") 1.98 (6'6")	3.35 (11'0") 2.41 (7'11")	DD	5300 (11,690)	3700 (8160)	2560 (5640)	1880 (4150)	1350 (2980)		
D4D	22C	67-68	65/—	5900 (13,100)	1.52 (5'0") 1.98 (6'6")	3.38 (11'1") 2.41 (7'11")	PS							
D4D	82J	63	—/65	7910 (17,440)	1.52 (5'0") 1.98 (6'6")	3.38 (11'1") 2.67 (8'9")	DD	6150 (13,550)	4150 (9140)	2820 (6210)	2030 (4480)	1420 (3120)		
D4D	83J	67-71	—/65	8270 (18,240)	1.52 (5'0") 1.98 (6'6")	3.38 (11'1") 2.67 (8'9")	PS							
D4D	83J	72-77	—/75	5900 (13,100)	1.52 (5'0") 1.98 (6'6")	3.38 (11'1") 2.67 (8'9")	DD	6150 (13,550)	4150 (9140)	2820 (6210)	2030 (4480)	1420 (3120)		
D4E	27X	77-84	80/—	9013 (19,820)	1.52 (5'0") 2.44 (8'0")	3.86 (12'8") 2.72 (8'11")	DD	6495 (14,320)	4425 (9756)	3018 (6654)	2172 (4788)	1509 (3327)		
D4E	28X	77-84	80/—	9090 (20,040)	1.52 (5'0") 2.44 (8'0")	3.86 (12'8") 2.72 (8'11")	PS							
D4G XL	CFN	01-03	80	7761 (17,110)	1.50 (4'11") 1.96 (6'5")	4.04 (13'3") 2.72 (8'11")	HYS							
D4G XL*	HYD	03-07	80	7800 (17,196)	1.50 (4'11") 1.96 (6'5")	4.04 (13'3") 2.72 (8'11")	HYS							

*Meets Tier 2/Stage II/Japan 2001 (Tier 2) equivalent emission standards.

NOTE: Power Shift models show speeds only, not drawbar pull.

NOTE: Track-Type Tractor weights do not include blades until 1967.

Track-Type Tractors (cont'd)

Model	Product Ident. No. Prefix	Years Built	Horsepower FW/ Drawbar	Approx. Machine Weight kg (lb)	Gauge m (ft) and Width m (ft)	Length m (ft) and Height m (ft)	Transmission	Rated Drawbar Pull — kg (lb) and Forward Speed — km/h (mph)						
								1st	2nd	3rd	4th	5th	6th	
D4G LGP	FDC	01-03	80	8109 (17,877)	1.68 (5'6") 2.31 (7'7")	4.04 (13'3") 2.72 (8'11")	HYS		0-9.0 (0-5.6)					
D4G LGP**	TLX	03-07	80	8143 (17,952)	1.68 (5'6") 2.31 (7'7")	4.04 (13'3") 2.72 (8'11")	HYS		0-9.0 (0-5.6)					
D4H (JPN)	8PB*	85-89	90/—	9975 (21,991)	1.67 (5'6") 2.13 (7'0")	3.422 (11'3") 2.933 (9'8")	PS	3.5 (2.2)	6.2 (3.9)	10.2 (6.3)				
D4H (JPN)	2AC*	85-89	90/—	10 111 (22,291)	1.67 (5'6") 2.13 (7'0")	3.422 (11'3") 2.933 (9'8")	DD	7618 (16,798)	5843 (12,884)	4333 (9554)	3207 (7071)	2335 (5149)	1640 (3617)	
D4H (JPN)	8PB*	89-90	95/—	10 105 (22,277)	1.67 (5'6") 2.13 (7'0")	3.422 (11'3") 2.933 (9'8")	PS	3.5 (2.2)	6.2 (3.9)	10.2 (6.3)				
D4H (JPN)	8PB	91-96	95/—	11 019 (24,242)	1.67 (5'6") 2.13 (7'0")	3.44 (11'3") 2.939 (9'8")	PS	3.5 (2.2)	6.2 (3.9)	10.2 (6.3)				
D4H (JPN)	2AC*	89-90	95/—	10 231 (22,555)	1.67 (5'6") 2.13 (7'0")	3.422 (11'3") 2.933 (9'8")	DD	7454 (16,434)	5715 (12,599)	4235 (9336)	3132 (6904)	2277 (5020)	1597 (3520)	
D4H (JPN)	2AC	91-96	95/—	11 019 (24,242)	1.67 (5'6") 2.13 (7'0")	3.44 (11'3") 2.939 (9'8")	DD	7454 (16,434)	5715 (12,599)	4235 (9336)	3132 (6904)	2227 (5020)	1597 (3520)	
D4H LGP (JPN)	9DB*	85-89	90/—	11 245 (24,790)	2.00 (6'7") 2.76 (9'1")	3.693 (10'4") 2.986 (9'10")	PS	3.5 (2.2)	6.2 (3.9)	10.2 (6.3)				
D4H LGP (JPN)	3AC*	85-89	90/—	11 381 (25,090)	2.00 (6'7") 2.76 (9'1")	3.693 (10'4") 2.986 (9'10")	DD	7618 (16,798)	5843 (12,884)	4333 (9554)	3207 (7071)	2335 (5149)	1640 (3617)	
D4H LGP (JPN)	9DB*	89-90	95/—	11 350 (25,022)	2.00 (6'7") 2.76 (9'1")	3.693 (10'4") 2.986 (9'10")	PS	3.5 (2.2)	6.2 (3.9)	10.2 (6.3)				
D4H LGP (JPN)	9DB	91-96	105/—	12 440 (27,368)	2.00 (6'7") 2.76 (9'1")	3.718 (12'2") 3.04 (10'0")	PS	3.4 (2.1)	6.0 (3.7)	10.2 (6.4)				

*D4H models prior to Series II. Product identification number prefix still in use for current product.

**Meets Tier 2/Stage II/Japan 2001 (Tier 2) equivalent emission standards.

NOTE: Power Shift models show speeds only, not drawbar pull.

NOTE: Track-Type Tractor weights do not include blades until 1967.

Track-Type Tractors (cont'd)

Model	Product Ident. No. Prefix	Years Built	Horse-power FW/ Drawbar	Approx. Machine Weight kg (lb)	Gauge m (ft) and Width m (ft)	Length m (ft) and Height m (ft)	Transmission	Rated Drawbar Pull — kg (lb) and Forward Speed — km/h (mph)					
								1st	2nd	3rd	4th	5th	6th
								D4H LGP (JPN)	3AC*	89-90	95/—	11 476 (25,300)	2.00 (6'7") 2.76 (9'1")
D4H LGP (JPN)	9GJ	92-96	105/—	12 440 (27,368)	2.00 (6'7") 2.76 (9'1")	3.718 (10'0") 3.04 (10'0")	PS			10.2 (6.4)			
D4H XL (JPN)	8PS	92-96	105/—	11 786 (25,929)	1.77 (5'10") 2.28 (7'6")	3.446 (11'4") 2.99 (9'10")	PS	3.4 (2.1)	6.0 (3.7)	10.2 (6.4)			
D5	81H	67-67	93/75	8300 (18,200)	1.52 (5'0") 2.02 (6'8")	3.89 (12'9") 2.00 (8'7")	DD	7870 (17,330) (2.3)	4910 (10,820) (2.9)	3330 (7320) (3.6)	2230 (4920) (4.4)	1440 (3170) (5.5)	
D5	82H	67-67	93/75	8400 (18,600)	1.88 (6'2") 2.38 (7'10")	3.89 (12'9") 2.00 (8'7")	DD	7870 (17,330) (1.7)	4910 (10,820) (2.6)	3330 (7320) (3.6)	2230 (4920) (5.0)	1440 (3170) (6.9)	
D5	83H	67-67	93/—	8500 (18,800)	1.52 (5'0") 2.02 (6'8")	3.89 (12'9") 2.64 (8'8")	PS		2.7 (1.7)	4.2 (2.6)	5.8 (3.6)	8.0 (5.0)	11.1 (6.9)
D5	84H	67-67	93/—	8700 (19,200)	1.88 (6'2") 2.38 (7'10")	3.89 (12'9") 2.64 (8'8")	PS		3.6 (2.2)	6.1 (3.8)	10.1 (6.3)		
D5	98J	67-77	105	11 290 (24,400)	1.52 (5'0") 2.02 (6'8")	3.89 (12'9") 2.74 (9'0")	DD	8770 (19,340) (2.5)	5500 (12,130) (3.0)	3750 (8270) (3.5)	2540 (4.0)	1660 (4.6)	9.0 (5.6)
D5	93J	67-77	105	11 290 (24,400)	1.52 (5'0") 2.02 (6'8")	3.89 (12'9") 2.74 (9'0")	DD	8770 (19,340) (1.7)	5500 (12,130) (2.6)	3750 (8270) (3.6)	2540 (5.0)	1660 (6.9)	
D5	94J	66-77	105	11 390 (25,100)	1.88 (6'2") 2.38 (7'10")	3.89 (12'9") 2.74 (9'0")	DD	8770 (19,340) (1.7)	5500 (12,130) (2.6)	3750 (8270) (3.6)	2540 (5.0)	1660 (6.9)	
D5	95J	66-77	105	11 290 (24,900)	1.52 (5'0") 2.02 (6'8")	3.89 (12'9") 2.74 (9'0")	PS		2.7 (1.7)	4.2 (2.6)	5.8 (3.6)	8.0 (5.0)	11.1 (6.9)
D5	96J	66-77	105	11 600 (25,600)	1.88 (6'2") 2.38 (7'10")	3.89 (12'9") 2.74 (9'0")	PS						

*D4H models prior to Series II. Product identification number prefix still in use for current product.

NOTE: Power Shift models show speeds only, not drawbar pull.

NOTE: Track-Type Tractor weights do not include blades until 1967.

Track-Type Tractors (cont'd)

Model	Product Ident. No. Prefix	Years Built	Horse-power FW/ Drawbar	Approx. Machine Weight kg (lb)	Gauge m (ft) and Width m (ft)	Length m (ft) and Height m (ft)	Transmission	Rated Drawbar Pull — kg (lb) and Forward Speed — km/h (mph)					
								1st	2nd	3rd	4th	5th	6th
D5B	25X	77-84	105/—	11 619 (25,615)	1.88 (6'2") 3.15 (10'4")	4.60 (15'1") 2.77 (9'1")	PS	3.5 (2.2)	6.1 (3.8)	10.1 (6.3)			
D5B	23X	77-82	105/—	11 283 (24,875)	1.88 (6'2") 3.15 (10'4")	4.60 (15'1") 2.77 (9'1")	DD	8060 (17,770)	5030 (11,100)	3410 (7520)	2290 (5060)	1480 (3260)	
D5C		91-93	90	8460 (18,650)	1.54 (5'1") 2.01 (6'7")		PS	3.5 (2.2)	6.3 (3.9)	10.0 (6.2)			
D5C Series III		93-01	90	8490 (18,710)	1.55 (5'1") 2.00 (6'7")	4.07 (13'4") 2.74 (9'0")	HYS		0-9.0 (0-5.6)				
D5C XL Series III		93-01	90	8820 (19,450)	1.55 (5'1") 2.06 (6'9")	4.32 (14'2") 2.74 (9'0")	HYS		0-9.0 (0-5.6)				
D5C LGP		91-93	90	8987 (19,800)	1.72 (5'8") 2.38 (7'10")		PS	3.5 (2.2)	6.3 (3.9)	10.0 (6.2)			
D5C LGP Series III		93-01	90	8970 (19,780)	1.73 (5'8") 2.39 (7'10")	4.07 (13'4") 2.74 (9'0")	HYS		0-9.0 (0-5.6)				
D5E		-99	105	11 700 (25,800)	1.52 (5'0")	3.88 (12'8")	DD	8770 (19,340)	5500 (12,130)	3750 (8270)	2450 (5600)	1660 (3660)	
D5G XL	FDH	01-03	90	8863 (19,540)	1.55 (5'1") 2.06 (6'9")	4.34 (14'3") 2.73 (8'11")	HYS		0-9.0 (0-5.6)				
D5G XL*	WGB	03-07	90	8919 (19,662)	1.55 (5'1") 2.06 (6'9")	4.34 (14'3") 2.73 (8'11")	HYS		0-9.0 (0-5.6)				
D5G LGP	FDW	01-03	90	9207 (20,298)	1.73 (5'8") 2.39 (7'10")	4.25 (13'11") 2.73 (8'11")	HYS		0-9.0 (0-5.6)				
D5G LGP*	RKG	03-07	90	9269 (20,434)	1.73 (5'8") 2.39 (7'10")	4.25 (13'11") 2.73 (8'11")	HYS		0-9.0 (0-5.6)				

*Meets Tier 2/Stage II/Japan 2001 (Tier 2) equivalent emission standards.

NOTE: Power Shift models show speeds only, not drawbar pull.

NOTE: Track-Type Tractor weights do not include blades until 1967.

Track-Type Tractors (cont'd)

Model	Product Ident. No. Prefix	Years Built	Horsepower FW/ Drawbar	Approx. Machine Weight kg (lb)	Gauge m (ft) and Width m (ft)	Length m (ft) and Height m (ft)	Transmission	Rated Drawbar Pull — kg (lb) and Forward Speed — km/h (mph)						
								1st	2nd	3rd	4th	5th	6th	
D5H (FR)	8RC*	85-90	120/—	12 144 (26,772)	1.8 (5'11")	3.6 (11'10")	PS	—	—	—				
					2.21 (7'3")	2.93 (9'7")		3.3 (2.1)	5.9 (3.7)	10.0 (6.2)				
D5H (FR)	8RC	91-96	120/—	13 250 (29,200)	1.8 (5'11")	3.6 (11'10")	DD							
					2.31 (7'7")	3.0 (9'10")		3.3 (2.1)	5.9 (3.7)	10.0 (6.2)				
D5H (FR)	7NC*	85-90	120/—	12 212 (26,922)	1.8 (5'11")	3.6 (11'10")	DD	9140 (20,150)	7005 (15,440)	5190 (11,440)	3835 (8450)	2785 (6140)	1950 (4300)	
					2.21 (7'3")	2.93 (9'7")		2.7 (1.7)	3.4 (2.1)	4.5 (2.8)	5.8 (3.6)	7.6 (4.7)	10.0 (6.2)	
D5H (FR)	7NC	91-96	120/—	13 250 (29,200)	1.8 (5'11")	3.6 (11'10")	DD	9140 (20,150)	7005 (15,440)	5190 (11,440)	3835 (8450)	2785 (6140)	1950 (4300)	
					2.31 (7'7")	3.0 (9'10")		2.7 (1.7)	3.4 (2.1)	4.5 (2.8)	5.8 (3.6)	7.6 (4.7)	10.0 (6.2)	
D5H LGP (FR)	1DD*	86-90	120/—	14 685 (32,380)	2.16 (7'1")	4.129 (13'7")	PS							
					3.02 (9'11")	3.069 (10'1")		3.3 (2.1)	5.9 (3.7)	10.0 (6.2)				
D5H LGP (FR)	1DD	91-96	130/—	16 200 (35,700)	2.16 (7'1")	4.133 (13'7")	PS							
					3.02 (9'11")	3.135 (10'3")		3.3 (2.1)	5.9 (3.7)	10.0 (6.2)				
D5H LGP (FR)	9HC*	85-90	120/—	14 878 (32,800)	2.16 (7'1")	4.129 (13'7")	DD	9140 (20,150)	7005 (15,440)	5190 (11,440)	3835 (8450)	2785 (6140)	1950 (4300)	
					3.02 (9'11")	3.069 (10'1")		2.7 (1.7)	3.4 (2.1)	4.5 (2.8)	5.8 (3.6)	7.6 (4.7)	10.0 (6.2)	
D5H LGP (FR)	9HC	91-96	130/—	16 200 (35,700)	2.16 (7'1")	4.133 (13'7")	DD	10 061 (22,181)	7725 (17,031)	5738 (12,650)	4256 (9384)	3109 (6855)	2195 (4840)	
					3.02 (9'11")	3.135 (10'3")		2.6 (1.6)	3.4 (2.1)	4.5 (2.7)	5.8 (3.6)	7.5 (4.7)	9.9 (6.2)	
D5H (JPN)	3MD*	86-90	120/—	12 144 (26,772)	1.8 (5'11")	3.6 (11'10")	PS							
					2.21 (7'3")	2.93 (9'7")		3.3 (2.1)	5.9 (3.7)	10.0 (6.2)				
D5H (JPN)	3MD	91-96	120/—	13 250 (29,200)	1.8 (5'11")	3.6 (11'10")	PS							
					2.31 (7'7")	3.0 (9'10")		3.3 (2.1)	5.9 (3.7)	10.0 (6.2)				
D5H (JPN)	1YD*	86-90	120/—	12 212 (26,922)	1.8 (5'11")	3.6 (11'10")	DD	9140 (20,150)	7005 (15,440)	5190 (11,440)	3835 (8450)	2785 (6140)	1950 (4300)	
					2.21 (7'3")	2.93 (9'7")		2.7 (1.7)	3.4 (2.1)	4.5 (2.8)	5.8 (3.6)	7.6 (4.7)	10.0 (6.2)	

*D5H models prior to Series II. Product identification number prefix still in use for current product.

NOTE: Power Shift models show speeds only, not drawbar pull.

NOTE: Track-Type Tractor weights do not include blades until 1967.

Track-Type Tractors (cont'd)

Model	Product Ident. No. Prefix	Years Built	Horse-power FW/ Drawbar	Approx. Machine Weight kg (lb)	Gauge m (ft) and Width m (ft)	Length m (ft) and Height m (ft)	Transmission	Rated Drawbar Pull — kg (lb) and Forward Speed — km/h (mph)					
								1st	2nd	3rd	4th	5th	6th
								D5H (JPN)	1YD*	91-96	120/—	13 250 (29,200)	1.8 (5'11")
D5H LGP (JPN)	4KD*	86-90	120/—	14 685 (32,380)	2.31 (7'7")	3.0 (9'10")	PS	2.7 (1.7)	3.4 (2.1)	4.5 (2.8)	5.8 (3.6)	7.6 (4.7)	10.0 (6.2)
D5H LGP (JPN)	4KD	91-96	130/—	16 200 (35,700)	2.16 (7'1")	4.129 (13'7")	PS	3.02 (2.1)	3.069 (3.6)	10.0 (6.2)			
D5H LGP (JPN)	2SD*	86-90	120/—	14 878 (32,800)	2.16 (7'1")	4.129 (13'7")	DD	9140 (20,150)	7005 (15,440)	5190 (11,440)	3835 (8450)	2785 (6140)	1950 (4300)
D5H LGP (JPN)	2SD	91-96	130/—	16 200 (35,700)	2.16 (7'1")	4.133 (13'7")	DD	2.7 (1.7)	3.4 (2.1)	4.5 (2.8)	5.8 (3.6)	7.6 (4.7)	10.0 (6.2)
D5H XL (FR)	8RJ	92-96	130/—	13 900 (30,600)	2.16 (7'1")	4.133 (13'7")	DD	10 061 (22,181)	7725 (17,031)	5738 (12,650)	4256 (9384)	3109 (6855)	2195 (4840)
D5M XL (FR)	4BR	96-02	82/110	12 250 (27,006)	3.02 (9'11")	3.135 (10'3")	PS	2.6 (1.6)	3.4 (2.1)	4.5 (2.7)	5.8 (3.6)	7.5 (4.7)	9.9 (6.2)
D5M XL (FR)	6GN	96-02	82/110	12 250 (27,006)	1.89 (6'2")	3.606 (11'10")	PS	2.49 (2.1)	3.08 (3.7)	10.0 (6.2)			
D5M LGP (FR)	3DR	96-02	82/110	13 100 (28,880)	1.77 (5'10")	3.544 (11'8")	PS	22 347 (49,264)	12 166 (26,821)	6745 (14,870)			
D5M LGP (FR)	3CR	96-02	82/110	13 100 (28,880)	2.33** (7'8")**	3.002*** (9'10")***	PS	3.27 (2.03)	5.81 (3.61)	9.93 (6.17)			
					1.77 (5'10")	3.544 (11'8")	PS	22 347 (49,264)	12 166 (26,821)	6745 (14,870)			
					2.33** (7'8")**	3.002*** (9'10")***	PS	3.27 (2.03)	5.81 (3.61)	9.93 (6.17)			
					2.00 (6'7")	3.72 (12'2")	PS	22 347 (49,264)	12 166 (26,821)	6745 (14,870)			
					2.76** (9'1")**	3.046*** (10'0")***	PS	3.27 (2.03)	5.81 (3.61)	9.93 (6.17)			
					2.00 (6'7")	3.72 (12'2")	PS	22 347 (49,264)	12 166 (26,821)	6745 (14,870)			
					2.76** (9'1")**	3.046*** (10'0")***	PS	3.27 (2.03)	5.81 (3.61)	9.93 (6.17)			

*D5H models prior to Series II. Product identification number prefix still in use for current product.
 **Width without blade and with standard shoes.
 ***Height with ROPS cab.
 NOTE: Power Shift models show speeds only, not drawbar pull.
 NOTE: Track-Type Tractor weights do not include blades until 1967.

Track-Type Tractors (cont'd)

Model	Product Ident. No. Prefix	Years Built	Horse-power FW/ Drawbar	Approx. Machine Weight kg (lb)	Gauge m (ft) and Width m (ft)	Length m (ft) and Height m (ft)	Transmission	Rated Drawbar Pull — kg (lb) and Forward Speed — km/h (mph)					
								1st	2nd	3rd	4th	5th	6th
								D6	4R	47-59	85	8042 (17,730)	1.88 (6'2") 1.52 (5'0")
D6	9U	47-59	93/75	8153 (17,975)	1.88 (6'2") 1.52 (5'0")	3.75 (12'4") 1.91 (6'3")	DD	8618 (19,000)	5534 (12,200)	3837 (8460)	2617 (5770)	1842 (4060)	
D6B	37A	59-67	93/75	8130 (17,930)	1.52 (5'0") 2.02 (6'8")	3.85 (12'9") 1.91 (6'3")	DD						
D6B	44A	59-67	93/75	8300 (18,300)	1.88 (6'2") 2.38 (7'10")	3.85 (12'9") 1.91 (6'3")	DD	7820 (16,240)	4940 (10,900)	3220 (7090)	2120 (4670)	1450 (3190)	
D6C	74A	63-67	120	10 400 (23,000)	1.88 (6'2") 2.38 (7'9")	3.95 (13'0") 1.92 (6'4")	DD	12 050 (26,540)	8020 (17,670)	5300 (11,690)	3360 (7400)	2030 (4470)	
D6C	76A	63-67	120	10 700 (23,500)	1.88 (6'2") 2.38 (7'9")	3.95 (13'0") 1.92 (6'4")	PS						
D6C	10K	67-76	140	13 880 (30,600)	1.88 (6'2") 2.38 (7'9")	3.73 (12'3") 2.87 (9'5")	PS						
D6 LGP	69U	72-77	140	17 010 (37,500)	2.11 (6'11") 3.02 (9'11")	3.94 (12'11") 2.97 (9'9")	PS	4.0 (2.5)	6.9 (4.3)	10.8 (6.7)			
D6C	99J	67-76	140	14 243 (31,400)	1.88 (6'2") 2.38 (7'9")	3.73 (12'3") 2.87 (9'5")	DD	11 500 (25,360)	7750 (17,090)	5180 (11,420)	3350 (7380)	2090 (4610)	
D6C LGP	69U	72-77	140	13 835 (30,500)	2.11 (6'11") 3.02 (9'11")	2.97 (9'9") 3.94 (12'11")	PS	2.7 (1.7)	4.0 (2.5)	5.6 (3.5)	7.9 (4.9)	11.1 (6.9)	

NOTE: Power Shift models show speeds only, not drawbar pull.
 NOTE: Track-Type Tractor weights do not include blades until 1967.

Track-Type Tractors (cont'd)

Model	Product Ident. No. Prefix	Years Built	Horsepower FW/Drawbar	Approx. Machine Weight kg (lb)	Gauge m (ft) and Width m (ft)	Length m (ft) and Height m (ft)	Transmission	Rated Drawbar Pull — kg (lb) and Forward Speed — km/h (mph)					
								1st	2nd	3rd	4th	5th	6th
								D6D	3X	77-86	140	14 290 (31,500)	1.88 (6'2") 2.36 (7'9")
D6D	4X	77-86	140	14 290 (31,500)	1.88 (6'2")	3.73 (12'3")	PS	1.7 (2.7)	4.0 (2.5)	5.6 (3.5)	7.9 (4.9)	11.1 (6.9)	
D6D LGP	6X	77-86	140	17 370 (38,300)	2.1 (6'11")	3.94 (12'1")	PS	4.0 (2.5)	6.9 (4.3)	10.8 (6.7)			
D6H	4RC*	85-90	165/—	16 950 (37,367)	1.88 (6'2") 2.64 (8'8")	4.069 (13'4") 3.114 (10'3")	PS	3.8 (2.4)	6.5 (4.0)	11.3 (7.0)			
D6H	8KB	85-88	165/—	16 954 (37,377)	1.88 (6'2") 2.64 (8'8")	4.069 (13'4") 3.114 (10'3")	DD	12 500 (27,560)	9520 (20,990)	7140 (15,740)	5440 (11,990)	4010 (8840)	2820 (6220)
D6H	3ZF*	88-90	165/—	17 055 (37,599)	1.88 (6'2") 2.64 (8'8")	4.069 (13'4") 3.114 (10'3")	PS/DS	2.7 (1.7)	3.5 (2.2)	4.6 (2.9)	5.8 (3.6)	7.6 (4.7)	10.0 (6.2)
D6H LGP	6FC*	87-90	165/—	19 555 (43,111)	2.225 (7'4") 3.43 (11'3")	4.493 (14'9") 3.164 (10'5")	PS	3.8 (2.4)	6.5 (4.0)	11.3 (7.0)			
D6H LGP	3YG*	88-90	165/—	19 527 (43,049)	2.225 (7'4") 3.43 (11'3")	4.493 (14'9") 3.164 (10'5")	PS/DS	3.8 (2.4)	6.5 (4.0)	11.3 (7.0)			
D6H (JPN)	2KD*	86-90	165/—	16 950 (37,367)	1.88 (6'2") 2.64 (8'8")	4.069 (13'4") 3.114 (10'3")	PS	3.8 (2.4)	6.5 (4.0)	11.3 (7.0)			
D6H (DS)	32F (E. Peoria) 4YF (Sagami) 6CF (Grenoble)	92-96	123/165	18 111 (39,928)	1.88 (6'2") 3.36 (11'0")	4.07 (13'4") 3.12 (10'3")	PS	3.8 (2.3)	6.6 (4.1)	11.4 (7.1)			

*D6H models prior to Series II. Product identification number prefix still in use for current product.

NOTE: Power Shift models show speeds only, not drawbar pull.

NOTE: Track-Type Tractor weights do not include blades until 1967.

Track-Type Tractors (cont'd)

Model	Product Ident. No. Prefix	Years Built	Horse-power FW/ Drawbar	Approx. Machine Weight kg (lb)	Gauge m (ft) and Width m (ft)	Length m (ft) and Height m (ft)	Transmission	Rated Drawbar Pull — kg (lb) and Forward Speed — km/h (mph)					
								1st	2nd	3rd	4th	5th	6th
D6H (CB)	4RC	92-96	123/165	17 997 (39,676)	1.88	4.07	PS						
	(E. Peoria) 2KD				3.36	3.12		3.8	6.6	11.4			
	(Sagami) 4LG				(11'0")	(10'3")		(2.3)	(4.1)	(7.1)			
D6H XL (DS)	9KJ	92-96	130/175	19 080 (42,063)	1.88	4.07	PS						
	(E. Peoria) 8SK				3.36	3.12		3.8	6.6	11.4			
	(Sagami) 9LK				(11'0")	(10'3")		(2.3)	(4.1)	(7.1)			
D6H XL (CB)	8ZJ	92-96	130/175	18 966 (41,811)	1.88	4.07	PS						
	(E. Peoria) 9RK				3.36	3.12		3.8	6.6	11.4			
	(Sagami) 8KK				(11'0")	(10'3")		(2.3)	(4.1)	(7.1)			
D6H XR (DS)	6CK	92-96	130/175	18 799 (41,444)	1.88	4.22	PS						
	(E. Peoria) 2TL				3.36	3.12		3.8	6.6	11.4			
	(Sagami) 1YL				(11'0")	(10'3")		(2.3)	(4.1)	(7.1)			
D6H XR (CB)	5KK	92-96	130/175	18 799 (41,444)	1.88	4.22	PS						
	(E. Peoria) 7ZK				3.36	3.12		3.8	6.6	11.4			
	(Sagami) 2BL				(11'0")	(10'3")		(2.3)	(4.1)	(7.1)			
D6H LGP (DS)	3YG	92-96	134/180	20 486 (45,163)	2.24	4.49	PS						
	(E. Peoria) 4GG				4.0	3.17		3.8	6.6	11.4			
	(Sagami) 5HF				(13'1")	(10'5")		(2.3)	(4.1)	(7.1)			
D6H LGP (CB)	6FC	92-96	134/180	20 486 (45,163)	2.24	4.49	PS						
	(E. Peoria) 1KD				4.0	3.17		3.8	6.6	11.4			
	(Sagami) 2TG				(13'1")	(10'5")		(2.3)	(4.1)	(7.1)			
D6H (JPN)	3ED*	86-92	165/—	16 954 (37,377)	1.88	4.069	DD	12 500	9520	7140	5440	4010	2820
					(6'2")	(13'4")		(27,560)	(20,990)	(15,740)	(11,990)	(8840)	(6220)
D6H (JPN)	4YF*	88-90	165/—	17 055 (37,599)	2.64	3.114	PS/DS	2.7	3.5	4.6	5.8	7.6	10.0
					(8'8")	(10'3")		(1.7)	(2.2)	(2.9)	(3.6)	(4.7)	(6.2)
					1.88	4.069		3.8	6.5	11.3			
					(6'2")	(13'4")		(2.4)	(4.0)	(7.0)			

*D6H models prior to Series II. Product identification number prefix still in use for current product.

NOTE: Power Shift models show speeds only, not drawbar pull.

NOTE: Track-Type Tractor weights do not include blades until 1967.

Track-Type Tractors (cont'd)

Model	Product Ident. No. Prefix	Years Built	Horse-power FW/ Drawbar	Approx. Machine Weight kg (lb)	Gauge m (ft) and Width m (ft)	Length m (ft) and Height m (ft)	Transmission	Rated Drawbar Pull — kg (lb) and Forward Speed — km/h (mph)					
								1st	2nd	3rd	4th	5th	6th
D6H LGP (JPN)	1KD*	86-90	165/—	19 555 (43,111)	2.225 (7'4") 3.43 (11'3")	4.493 (14'9") 3.164 (10'5")	PS	3.8 (2.4)	6.5 (4.0)	11.3 (7.0)			
D6H LGP (JPN)	8FC*	86-90	165/—	19 676 (43,380)	2.225 (7'4") 3.43 (11'3")	4.485 (14'9") 3.164 (10'5")	DD	12 500 (27,560)	9520 (20,990)	7140 (15,740)	5440 (11,990)	4010 (8840)	2820 (6220)
D6H LGP (JPN)	4GG*	88-90	165/—	19 527 (43,049)	2.225 (7'4") 3.43 (11'3")	4.493 (14'9") 3.164 (10'5")	PS/DS	2.7 (1.7)	3.5 (2.2)	4.6 (2.9)	5.8 (3.6)	7.6 (4.7)	10.0 (6.2)
D6H (FR)	4LG*	87-90	165/—	16 950 (37,367)	1.88 (6'2") 2.64 (8'8")	4.069 (13'4") 3.114 (10'3")	PS	3.8 (2.4)	6.5 (4.0)	11.3 (7.0)			
D6H (FR)	1FJ*	88-90	165/—	16 954 (37,377)	1.88 (6'2") 2.64 (8'8")	4.069 (13'4") 3.114 (10'3")	DD	12 500 (27,560)	9520 (20,990)	7140 (15,740)	5440 (11,990)	4010 (8840)	2820 (6220)
D6H (FR)	6CF*	88-90	165/—	17 055 (37,599)	1.88 (6'2") 2.64 (8'8")	4.069 (13'4") 3.114 (10'3")	PS/DS	2.7 (1.7)	3.5 (2.2)	4.6 (2.9)	5.8 (3.6)	7.6 (4.7)	10.0 (6.2)
D6H LGP (FR)	2TG*	87-90	165/—	19 555 (43,111)	2.225 (7'4") 3.43 (11'3")	4.493 (14'9") 3.164 (10'5")	PS	3.8 (2.4)	6.5 (4.0)	11.3 (7.0)			
D6H LGP (FR)	5HF*	88-90	165/—	19 527 (43,049)	2.225 (7'4") 3.43 (11'3")	4.493 (14'9") 3.164 (10'5")	PS/DS	3.8 (2.4)	6.5 (4.0)	11.3 (7.0)			
D6H (SCOT)	7PC	86-87	165/—	16 950 (37,367)	1.88 (6'2") 2.64 (8'8")	4.069 (13'4") 3.114 (10'3")	PS	3.8 (2.4)	6.5 (4.0)	11.3 (7.0)			
D6H LGP (SCOT)	8YC	86-87	165/—	19 555 (43,111)	2.225 (7'4") 3.43 (11'3")	4.493 (14'9") 3.164 (10'5")	PS	3.8 (2.4)	6.5 (4.0)	11.3 (7.0)			
D6K XL	FBH	05-14	125	12 886 (28,409)	1.77 (5'10") 2.33 (7'8")	2.65 (8'8") 2.91 (9'7")	Hystat						
D6K LGP	DHA	05-13	125	13 467 (29,690)	2 (6'7") 2.76 (9'1")	2.65 (8'8") 2.91 (9'7")	Hystat						

*D6H models prior to Series II. Product identification number prefix still in use for current product.

NOTE: Power Shift models show speeds only, not drawbar pull.

NOTE: Track-Type Tractor weights do not include blades until 1967.

Track-Type Tractors (cont'd)

Model	Product Ident. No. Prefix	Years Built	Horse-power FW/ Drawbar	Approx. Machine Weight kg (lb)	Gauge m (ft) and Width m (ft)	Length m (ft) and Height m (ft)	Transmission	Rated Drawbar Pull — kg (lb) and Forward Speed — km/h (mph)					
								1st	2nd	3rd	4th	5th	6th
D6R STD CB (US)	2YN	95-02	165/—	18 100 (40,000)	1.88 (6'2") 2.64 (8'8")	4.08 (13'4") 3.20 (10'6")	PS	4.0 (2.5)	7.1 (4.4)	12.4 (7.7)			
D6R STD CB (BRAZIL)	9ZS	97-02	165/—	18 100 (40,000)	1.88 (6'2") 2.64 (8'8")	4.08 (13'4") 3.20 (10'6")	PS	4.0 (2.5)	7.1 (4.4)	12.4 (7.7)			
D6R STD CB (FRANCE)	2HM	96-01	165/—	18 100 (40,000)	1.88 (6'2") 2.64 (8'8")	4.08 (13'4") 3.20 (10'6")	PS	4.0 (2.5)	7.1 (4.4)	12.4 (7.7)			
D6R STD CB (JAPAN)	6FR	96-02	165/—	18 100 (40,000)	1.88 (6'2") 2.64 (8'8")	4.08 (13'4") 3.20 (10'6")	PS	4.0 (2.5)	7.1 (4.4)	12.4 (7.7)			
D6R STD DS (US)	3ZN	95-02	165/—	18 300 (40,400)	1.88 (6'2") 2.64 (8'8")	4.08 (13'4") 3.20 (10'6")	PS	4.0 (2.5)	7.1 (4.4)	12.4 (7.7)			
D6R STD DS (BRAZIL)	1RW	97-02	165/—	18 300 (40,400)	1.88 (6'2") 2.64 (8'8")	4.08 (13'4") 3.20 (10'6")	PS	3.9 (2.4)	6.8 (4.2)	11.9 (7.6)			
D6R STD DS (FRANCE)	4FM	96-01	165/—	18 300 (40,400)	1.88 (6'2") 2.64 (8'8")	4.08 (13'4") 3.20 (10'6")	PS	3.9 (2.4)	6.8 (4.2)	11.9 (7.6)			
D6R STD DS (JAPAN)	5PR	97-02	165/—	18 300 (40,400)	1.88 (6'2") 2.64 (8'8")	4.08 (13'4") 3.20 (10'6")	PS	3.9 (2.4)	6.8 (4.2)	11.9 (7.6)			
D6R XL CB (US)	4MN	96-02	175/—	19 000 (41,900)	1.88 (6'2") 2.64 (8'8")	4.08 (13'4") 3.20 (10'6")	PS	4.0 (2.5)	7.1 (4.4)	12.4 (7.7)			
D6R XL CB (BRAZIL)	6MR	97-02	175/—	19 000 (41,900)	1.88 (6'2") 2.64 (8'8")	4.08 (13'4") 3.20 (10'6")	PS	4.0 (2.5)	7.1 (4.4)	12.4 (7.7)			
D6R XL CB (FRANCE)	4JR	96-01	175/—	19 000 (41,900)	1.88 (6'2") 2.64 (8'8")	4.08 (13'4") 3.20 (10'6")	PS	4.0 (2.5)	7.1 (4.4)	12.4 (7.7)			
D6R XL CB (JAPAN)	4WR	97-02	175/—	19 000 (41,900)	1.88 (6'2") 2.64 (8'8")	4.08 (13'4") 3.20 (10'6")	PS	4.0 (2.5)	7.1 (4.4)	12.4 (7.7)			

NOTE: Power Shift models show speeds only, not drawbar pull.

NOTE: Track-Type Tractor weights do not include blades until 1967.

Track-Type Tractors (cont'd)

Model	Product Ident. No. Prefix	Years Built	Horsepower FW/ Drawbar	Approx. Machine Weight kg (lb)	Gauge m (ft) and Width m (ft)	Length m (ft) and Height m (ft)	Transmission	Rated Drawbar Pull — kg (lb) and Forward Speed — km/h (mph)					
								1st	2nd	3rd	4th	5th	6th
D6R XL DS (US)	5LN	95-02	175/—	19 200 (42,300)	1.88 (6'2") 2.64 (8'8")	4.08 (13'4") 3.20 (10'6")	PS	3.9 (2.4)	6.8 (4.2)	11.9 (7.6)			
D6R XL DS (BRAZIL)	7GR	96-02	175/—	19 200 (42,300)	1.88 (6'2") 2.64 (8'8")	4.08 (13'4") 3.20 (10'6")	PS	3.9 (2.4)	6.8 (4.2)	11.9 (7.6)			
D6R XL DS (FRANCE)	9BM	96-01	175/—	19 200 (42,300)	1.88 (6'2") 2.64 (8'8")	4.08 (13'4") 3.20 (10'6")	PS	3.9 (2.4)	6.8 (4.2)	11.9 (7.6)			
D6R XL DS (JAPAN)	5RR	97-02	175/—	19 200 (42,300)	1.88 (6'2") 2.64 (8'8")	4.08 (13'4") 3.20 (10'6")	PS	3.9 (2.4)	6.8 (4.2)	11.9 (7.6)			
D6R XR CB (US)	6JN	95-02	175/—	18 780 (41,400)	1.88 (6'2") 2.64 (8'8")	4.22 (13'10") 3.19 (10'5")	PS	4.0 (2.5)	7.1 (4.4)	12.4 (7.7)			
D6R XR CB (FRANCE)	8XN	97-01	175/—	18 780 (41,400)	1.88 (6'2") 2.64 (8'8")	4.22 (13'10") 3.19 (10'5")	PS	4.0 (2.5)	7.1 (4.4)	12.4 (7.7)			
D6R XR CB (JAPAN)	6HR	97-02	175/—	18 780 (41,400)	1.88 (6'2") 2.64 (8'8")	4.22 (13'10") 3.19 (10'5")	PS	4.0 (2.5)	7.1 (4.4)	12.4 (7.7)			
D6R XR DS (US)	7KN	95-02	175/—	18 910 (41,700)	1.88 (6'2") 2.64 (8'8")	4.22 (13'10") 3.19 (10'5")	PS	3.9 (2.4)	6.8 (4.2)	11.9 (7.6)			
D6R XR DS (FRANCE)	9MN	97-01	175/—	18 910 (41,700)	1.88 (6'2") 2.64 (8'8")	4.22 (13'10") 3.19 (10'5")	PS	3.9 (2.4)	6.8 (4.2)	11.9 (7.6)			
D6R XR DS (JAPAN)	7DR	97-02	175/—	18 910 (41,700)	1.88 (6'2") 2.64 (8'8")	4.22 (13'10") 3.19 (10'5")	PS	3.9 (2.4)	6.8 (4.2)	11.9 (7.6)			
D6R LGP CB (US)	8LN	95-02	185/—	20 500 (45,200)	2.23 (7'3") 3.43 (11'3")	4.24 (13'11") 3.19 (10'5")	PS	4.0 (2.5)	7.1 (4.4)	12.4 (7.7)			
D6R LGP CB (FRANCE)	4HN	97-01	185/—	20 500 (45,200)	2.23 (7'3") 3.43 (11'3")	4.24 (13'11") 3.19 (10'5")	PS	4.0 (2.5)	7.1 (4.4)	12.4 (7.7)			

NOTE: Power Shift models show speeds only, not drawbar pull.
 NOTE: Track-Type Tractor weights do not include blades until 1967.

Track-Type Tractors (cont'd)

Model	Product Ident. No. Prefix	Years Built	Horse-power FW/ Drawbar	Approx. Machine Weight kg (lb)	Gauge m (ft) and Width m (ft)	Length m (ft) and Height m (ft)	Transmission	Rated Drawbar Pull — kg (lb) and Forward Speed — km/h (mph)					
								1st	2nd	3rd	4th	5th	6th
D6R LGP CB (JAPAN)	7AR	97-01	185/—	20 500 (45,200)	2.23 (7'3")	4.24 (13'11")	PS	4.0 (2.5)	7.1 (4.4)	12.4 (7.7)			
D6R LGP DS (US)	9PN	95-02	185/—	20 680 (45,600)	2.23 (7'3")	4.24 (13'11")	PS	3.9 (2.4)	6.8 (4.2)	11.9 (7.6)			
D6R LGP DS (FRANCE)	8TM	96-01	185/—	20 680 (45,600)	2.23 (7'3")	4.24 (13'11")	PS	3.9 (2.4)	6.8 (4.2)	11.9 (7.6)			
D6R LGP DS (JAPAN)	4TR	96-02	185/—	20 680 (45,600)	2.23 (7'3")	4.24 (13'11")	PS	3.9 (2.4)	6.8 (4.2)	11.9 (7.6)			
D6R LGP DD (JAPAN)	6GR	95-02	185/—	20 680 (45,600)	2.23 (7'3")	4.24 (13'11")	PS	3.4 (2.1)	5.9 (3.7)	10.4 (6.5)			
D6M XL (FR)	9ZM	96-02	104/140	15 530 (34,240)	1.89 (6'2")	3.74 (12'3")	PS	30 493 (67,222)	16 643 (36,689)	9211 (20,306)			
D6M XL (FR)	3WN	96-02	104/140	15 530 (34,240)	1.89 (6'2")	3.74 (12'3")	PS	30 493 (67,222)	16 643 (36,689)	9211 (20,306)			
D6M LGP (FR)	2RN	96-02	104/140	16 930 (37,320)	2.16 (7'1")	4.146 (13'7")	PS	30 493 (67,222)	16 643 (36,689)	9211 (20,306)			
D6M LGP (FR)	4JN	96-02	104/140	16 930 (37,320)	2.16 (7'1")	4.146 (13'7")	PS	30 493 (67,222)	16 643 (36,689)	9211 (20,306)			
D6R SII STD CB (FTC) (US)	AEM	02-05	123/165	17 826 (39,300)	1.88 (6'2")	3.86 (12'8")	PS	3.8 (2.4)	6.6 (4.1)	11.5 (7.2)			
D6R SII STD CB (FTC) (BRAZIL)	BRJ	02-06	123/165	17 826 (39,300)	1.88 (6'2")	3.86 (12'8")	PS	3.8 (2.4)	6.6 (4.1)	11.5 (7.2)			
D6R SII STD CB (FTC) (FRANCE)	BLE	01-05	123/165	17 826 (39,300)	1.88 (6'2")	3.86 (12'8")	PS	3.8 (2.4)	6.6 (4.1)	11.5 (7.2)			

*Width without blade and with standard shoes.

**Height with ROPS cab.

NOTE: Power Shift models show speeds only, not drawbar pull.

NOTE: Track-Type Tractor weights do not include blades until 1967.

Track-Type Tractors (cont'd)

Model	Product Ident. No. Prefix	Years Built	Horse-power FW/ Drawbar	Approx. Machine Weight kg (lb)	Gauge m (ft) and Width m (ft)	Length m (ft) and Height m (ft)	Transmission	Rated Drawbar Pull — kg (lb) and Forward Speed — km/h (mph)					
								1st	2nd	3rd	4th	5th	6th
D6R SII STD CB (FTC) (JAPAN)	BMK	01-06	123/165	17 826 (39,300)	1.88 (6'2") 2.64 (8'8")	3.86 (12'8") 3.2 (10'6")	PS	3.8 (2.4)	6.6 (4.1)	11.5 (7.2)			
D6R SII STD DS (US)	AFM	01-05	123/165	18 099 (39,900)	1.88 (6'2") 2.64 (8'8")	3.86 (12'8") 3.2 (10'6")	PS	3.8 (2.3)	6.6 (4.1)	11.4 (7.1)			
D6R SII STD DS (BRAZIL)	BPM	03-06	123/165	18 099 (39,900)	1.88 (6'2") 2.64 (8'8")	3.86 (12'8") 3.2 (10'6")	PS	3.8 (2.3)	6.6 (4.1)	11.4 (7.1)			
D6R SII STD DS (FRANCE)	BLT	02-05	123/165	18 099 (39,900)	1.88 (6'2") 2.64 (8'8")	3.86 (12'8") 3.2 (10'6")	PS	3.8 (2.3)	6.6 (4.1)	11.4 (7.1)			
D6R SII STD DS (JAPAN)	BNL	01-06	123/165	18 099 (39,900)	1.88 (6'2") 2.64 (8'8")	3.86 (12'8") 3.2 (10'6")	PS	3.8 (2.3)	6.6 (4.1)	11.4 (7.1)			
D6R SII XL CB (FTC) (US)	AGM	00-05	138/185	18 711 (41,250)	1.88 (6'2") 2.64 (8'8")	3.86 (12'8") 3.2 (10'6")	PS	3.8 (2.4)	6.6 (4.1)	11.5 (7.2)			
D6R SII XL CB (FTC) (BRAZIL)	CAD	02-06	138/185	18 711 (41,250)	1.88 (6'2") 2.64 (8'8")	3.86 (12'8") 3.2 (10'6")	PS	3.8 (2.4)	6.6 (4.1)	11.5 (7.2)			
D6R SII XL CB (FTC) (FRANCE)	BMJ	02-05	138/185	18 711 (41,250)	1.88 (6'2") 2.64 (8'8")	3.86 (12'8") 3.2 (10'6")	PS	3.8 (2.4)	6.6 (4.1)	11.5 (7.2)			
D6R SII XL CB (FTC) (JAPAN)	BPS	01-06	138/185	18 711 (41,250)	1.88 (6'2") 2.64 (8'8")	3.86 (12'8") 3.2 (10'6")	PS	3.8 (2.4)	6.6 (4.1)	11.5 (7.2)			
D6R SII XL DS (US)	AAX	00-05	138/185	18 847 (41,550)	1.88 (6'2") 2.64 (8'8")	3.86 (12'8") 3.2 (10'6")	PS	3.8 (2.3)	6.6 (4.1)	11.4 (7.1)			
D6R SII XL DS (BRAZIL)	FDT	02-06	138/185	18 847 (41,550)	1.88 (6'2") 2.64 (8'8")	3.86 (12'8") 3.2 (10'6")	PS	3.8 (2.3)	6.6 (4.1)	11.4 (7.1)			
D6R SII XL DS (FRANCE)	BMY	01-05	138/185	18 847 (41,550)	1.88 (6'2") 2.64 (8'8")	3.86 (12'8") 3.2 (10'6")	PS	3.8 (2.3)	6.6 (4.1)	11.4 (7.1)			

NOTE: Power Shift models show speeds only, not drawbar pull.
NOTE: Track-Type Tractor weights do not include blades until 1967.

Track-Type Tractors (cont'd)

Model	Product Ident. No. Prefix	Years Built	Horse-power FW/ Drawbar	Approx. Machine Weight kg (lb)	Gauge m (ft) and Width m (ft)	Length m (ft) and Height m (ft)	Transmission	Rated Drawbar Pull — kg (lb) and Forward Speed — km/h (mph)					
								1st	2nd	3rd	4th	5th	6th
D6R SII XL DS (JAPAN)	BRZ	01-06	138/185	18 847 (41,550)	1.88 (6'2")	3.86 (12'8")	PS	3.8 (2.3)	6.6 (4.1)	11.4 (7.1)			
D6R SII XW DS (US)	AEP	2001	138/185	19 550 (43,100)	2.03 (6'8")	3.86 (12'8")	PS	3.8 (2.3)	6.6 (4.1)	11.4 (7.1)			
D6R SII XW DS (FRANCE)	DAE	02-05	138/185	19 550 (43,100)	2.03 (6'8")	3.86 (12'8")	PS	3.8 (2.3)	6.6 (4.1)	11.4 (7.1)			
D6R SII XW DS (JAPAN)	BRE	01-06	138/185	19 550 (43,100)	2.03 (6'8")	3.86 (12'8")	PS	3.8 (2.3)	6.6 (4.1)	11.4 (7.1)			
D6R SII LGP CB (FTC) (US)	ACJ	01-05	138/185	20 865 (46,000)	2.23 (7'3")	4.24 (13'11")	PS	3.8 (2.4)	6.6 (4.1)	11.5 (7.2)			
D6R SII LGP CB (FTC) (JAPAN)	BPP	01-06	138/185	20 865 (46,000)	2.23 (7'3")	4.24 (13'11")	PS	3.8 (2.4)	6.6 (4.1)	11.5 (7.2)			
D6R SII LGP DS (US)	ADE	00-05	138/185	21 047 (46,400)	2.23 (7'3")	4.24 (13'11")	PS	3.8 (2.3)	6.6 (4.1)	11.4 (7.1)			
D6R SII LGP DS (FRANCE)	BNC	01-05	138/185	21 047 (46,400)	2.23 (7'3")	4.24 (13'11")	PS	3.8 (2.3)	6.6 (4.1)	11.4 (7.1)			
D6R SII LGP DS (JAPAN)	BPZ	01-06	138/185	21 047 (46,400)	2.23 (7'3")	4.24 (13'11")	PS	3.8 (2.3)	6.6 (4.1)	11.4 (7.1)			
D6R SIII (US)	HCD	05-07	138/185	18 326 (40,400)	1.88 (6'2")	3.86 (12'8")	PS	3.8 (2.3)	6.6 (4.1)	11.4 (7.1)			
(BRAZIL)	GMT	06-07				3.20 (10'6")							
(FRANCE)	TBC	06-07				3.8 (10'6")							
D6R SIII (JAPAN)	JEK	06-10	138/185	18 326 (40,400)	1.88 (6'2")	2.67 (8'9")	PS	3.8 (2.3)	6.6 (4.1)	11.4 (7.1)			
D6R SIII XL (US)	GJB	05-07	149/200	20 081 (44,270)	1.88 (6'2")	3.86 (12'8")	PS	3.8 (2.3)	6.6 (4.1)	11.4 (7.1)			
(BRAZIL)	JDL	05-07				2.13 (7'0")							
(FRANCE)	LFM	06-07				2.87 (9'5")							
D6R SIII XL (JAPAN)	EXL	06-12	149/200	20 081 (44,270)	1.88 (6'2")	2.87 (9'5")	PS	3.8 (2.3)	6.6 (4.1)	11.4 (7.1)			

NOTE: Power Shift models show speeds only, not drawbar pull.

NOTE: Track-Type Tractor weights do not include blades until 1967.

Track-Type Tractors (cont'd)

Model	Product Ident. No. Prefix	Years Built	Horse-power FW/ Drawbar	Approx. Machine Weight kg (lb)	Gauge m (ft) and Width m (ft)	Length m (ft) and Height m (ft)	Transmission	Rated Drawbar Pull — kg (lb) and Forward Speed — km/h (mph)					
								1st	2nd	3rd	4th	5th	6th
D6R SIII XL PAT (US) (FRANCE)	HKE RFC	05-07 06-07	149/200	20 081 (44,270)	1.88 (6'2") 2.13 (7'0")	3.86 (12'8") 3.20 (10'6")	PS	3.8 (2.3)	6.6 (4.1)	11.4 (7.1)			
D6R SIII XW (US) (BRAZIL)	MRT DPS	05-07 06-07	149/200	20 672 (45,573)	2.03 (6'8") 2.29 (7'6")	3.86 (12'8") 3.20 (10'6")	PS	3.8 (2.3)	6.6 (4.1)	11.4 (7.1)			
D6R SIII XW PAT (US) (FRANCE)	HDC MTJ	05-07 05-07	149/200	20 672 (45,573)	2.03 (6'8") 2.29 (7'6")	3.86 (12'8") 3.20 (10'6")	PS	3.8 (2.3)	6.6 (4.1)	11.4 (7.1)			
D6R SIII XW (JAPAN)	EXW	07-09	149/200	20 672 (45,573)	2.03 (6'8")	2.87 (9'5")	PS	3.8 (2.3)	6.6 (4.1)	11.4 (7.1)			
D6R SIII LGP (US) (FRANCE)	WRG DMK	05-07 06-07	149/200	21 716 (47,874)	2.29 (7'6") 2.29 (7'6")	4.25 (13'11") 3.25 (10'8")	PS	3.8 (2.3)	6.6 (4.1)	11.4 (7.1)			
D6R SIII LGP (JAPAN)	LGP	06-12	149/200	21 716 (47,874)	2.29 (7'6")	3.28 (10'9")	PS	3.8 (2.3)	6.6 (4.1)	11.4 (7.1)			
D6R SIII LGP PAT (US) (FRANCE)	WCB DLM	05-07 05-07	149/200	21 716 (47,874)	2.29 (7'6") 2.29 (7'6")	4.25 (13'11") 3.25 (10'8")	PS	3.8 (2.3)	6.6 (4.1)	11.4 (7.1)			
D6T XL*	GMK	11-14	207	21 306 (46,791)	1.88 (6'2") 2.64 (8'8")	3.86 (12'8") 3.13 (10'2")	PS/DS	36 936 (81,430)	22 343 (49,260)	12 124 (26,730)	12 124 (26,730)		
D6T XL VPAT*	DTD	11-14	207	23 663 (52,167)	2.13 (7'0") 3.13 (10'2")	3.86 (12'8") 3.13 (10'2")	PS/DS	36 936 (81,430)	22 343 (49,260)	12 124 (26,730)	12 124 (26,730)		
D6T XW*	SLJ	11-14	207	22 191 (48,922)	2.03 (6'8") 2.95 (9'8")	3.86 (12'8") 3.13 (10'2")	PS/DS	36 936 (81,430)	22 343 (49,260)	12 124 (26,730)	12 124 (26,730)		
D6T XW VPAT*	RCW	11-14	207	24 118 (53,170)	2.29 (7'6") 3.18 (10'5")	4.25 (13'11") 3.18 (10'5")	PS/DS	36 936 (81,430)	22 343 (49,260)	12 124 (26,730)	12 124 (26,730)		
D6T LGP*	ZJB	11-14	207	24 020 (52,954)	2.29 (7'6") 3.48 (11'5")	4.25 (13'11") 3.18 (10'5")	PS/DS	36 936 (81,430)	22 343 (49,260)	12 124 (26,730)	12 124 (26,730)		
D6T LGP VPAT*	KSB	11-14	207	22 009 (48,521)	2.29 (7'6") 3.18 (10'5")	4.25 (13'11") 3.18 (10'5")	PS/DS	36 936 (81,430)	22 343 (49,260)	12 124 (26,730)	12 124 (26,730)		

*Meets Tier 4 Interim/Stage IIIB/Japan 2011 (Tier 4 Interim) emission standards.

NOTE: Power Shift models show speeds only, not drawbar pull.

NOTE: Track-Type Tractor weights do not include blades until 1967.

Track-Type Tractors (cont'd)

Model	Product Ident. No. Prefix	Years Built	Horse-power FW/ Drawbar	Approx. Machine Weight kg (lb)	Gauge m (ft) and Width m (ft)	Length m (ft) and Height m (ft)	Transmission	Rated Drawbar Pull — kg (lb) and Forward Speed — km/h (mph)						
								1st	2nd	3rd	4th	5th	6th	
D7	3T	54-55	108/90	11 770 (25,925)	1.88 (6'2") 2.64 (8'1")	4.27 (14'0") 2.06 (6'10")	DD							
D7C	17A	55-59	128/102	11 954 (26,355)	1.88 (6'2") 2.64 (8'1")	4.26 (14'0") 2.06 (6'10")	DD	11 759 (25,900)	8045 (17,720)	4521 (11,960)	3428 (7550)	2397 (5280)		
D7D	17A	59-61	140/112	12 056 (26,555)	1.88 (6'2") 2.64 (8'1")	4.26 (14'0") 2.06 (6'10")	DD	12 300 (27,100)	8600 (18,900)	5700 (12,550)	3650 (8080)	2600 (5720)		
D7E	47A	61-68	160/128	14 787 (32,590)	1.98 (6'6") 2.56 (8'5")	4.47 (14'8") 2.30 (7'7")	DD	14 741 (32,500)	10 296 (22,700)	6803 (15,000)	4259 (9390)	3070 (6770)		
D7E	48A	61-66	160/128	14 787 (32,590)	1.98 (6'6") 2.56 (8'5")	4.47 (14'8") 2.30 (7'7")	PS							
D7E	47A	66-69	180/144	15 200 (33,500)	1.98 (6'6") 2.56 (8'5")	4.47 (14'8") 2.18 (7'2")	DD	17 140 (37,750)	11 350 (25,000)	7420 (16,340)	4540 (9990)	3180 (7010)		
D7E	48A	66-69	180	15 500 (34,000)	1.98 (6'6") 2.56 (8'5")	4.47 (14'8") 2.18 (7'2")	PS							
D7E*	TAN	10-14	235	26 055 (57,441)	1.98 (6'6") 2.88 (9'5")	4.6 (15'1") 3.36 (11'0")	E							
D7E LGP*	TJA	10-14	235	28 525 (62,886)	2.28 (7'6") 3.42 (11'3")	4.6 (15'1") 3.36 (11'0")	E							
D7F	94N	69-74	180	14 700 (32,400)	1.98 (6'6") 2.56 (8'5")	4.15 (13'8") 2.26 (7'5")	PS							
D7F	93N	69-74	180	14 700 (32,400)	1.98 (6'6") 2.56 (8'5")	4.15 (13'8") 2.26 (7'5")	DD	17 100 (37,600)	11 350 (25,000)	7450 (16,400)	4580 (10,000)	3240 (7140)		

*Meets Tier 4 Interim/Stage IIIB/Japan 2011 (Tier 4 Interim) emission standards.

NOTE: Power Shift models show speeds only, not drawbar pull.

NOTE: Track-Type Tractor weights do not include blades until 1967.

Track-Type Tractors (cont'd)

Model	Product Ident. No. Prefix	Years Built	Horse-power FW/ Drawbar	Approx. Machine Weight kg (lb)	Gauge m (ft) and Width m (ft)	Length m (ft) and Height m (ft)	Transmission	Rated Drawbar Pull — kg (lb) and Forward Speed — km/h (mph)						
								1st	2nd	3rd	4th	5th	6th	
D7G	92V	77-86	200	20 090 (44,300)	1.98 (6'6") 2.62 (8'7")	4.19 (13'9") 3.35 (11'0")	PS	3.7 (2.3)	6.4 (4.0)	10.0 (6.2)				
D7G	91V	77-86	200	20 090 (44,300)	1.98 (6'6") 2.62 (8'7")	4.19 (13'9") 3.35 (11'0")	DD	17 690 (39,010)	11 730 (25,860)	7680 (16,940)	4700 (10,370)	3320 (7320)		
D7G (JAPAN)	65V	75-07	149/200	20 580 (45,381)	1.98 (6'6")	2.72 (8'11")	PS	3.7 (2.3)	6.4 (4.0)	10.0 (6.2)				
D7G (INDONESIA)	7MB	83-07	149/200	20 580 (45,381)	1.98 (6'6")	2.72 (8'11")	PS	3.7 (2.3)	6.4 (4.0)	10.0 (6.2)				
D7G LGP	72W	77-86	200	22 630 (52,100)	2.18 (7'2") 3.3 (10'11")	4.22 (13'9") 3.28 (10'9")	PS	3.7 (2.3)	6.4 (4.0)	10.0 (6.2)				
D7G SII (INDONESIA)	7MB	08-12	149/200	20 580 (45,381)	1.98 (6'6")	2.72 (8'11")	PS	3.7 (2.3)	6.4 (4.0)	10.0 (6.2)				
D7G SII (CHINA)	C7G	06-11	149/200	20 580 (45,381)	1.98 (6'6")	2.72 (8'11")	PS	3.7 (2.3)	6.4 (4.0)	10.0 (6.2)				
D7H (CB)	79Z (E. Peoria) 4AB (Sagami)	92-96	171/230	24 778 (54,635)	1.98 (6'6") 3.9 (12'10")	4.74 (15'6") 3.5 (11'6")	PS	3.5 (2.2)	6.2 (3.8)	10.6 (6.6)				
D7H (DS)	5BF (E. Peoria) 2RG (Sagami)	92-96	171/230	25 077 (55,295)	1.98 (6'6") 3.9 (12'10")	4.74 (15'6") 3.5 (11'6")	PS	3.5 (2.2)	6.2 (3.8)	10.6 (6.6)				
D7H LGP (CB)	80Z (E. Peoria) 5WB (Sagami)	92-96	171/230	27 065 (59,678)	2.24 (7'4") 4.50 (14'9")	4.74 (15'6") 3.58 (11'9")	PS	3.5 (2.2)	6.2 (3.8)	10.6 (6.6)				
D7H LGP (DS)	4FG (E. Peoria) 3XG (Sagami)	92-96	171/230	27 065 (59,678)	2.24 (7'4") 4.50 (14'9")	4.74 (15'6") 3.58 (11'9")	PS	3.5 (2.2)	6.2 (3.8)	10.6 (6.6)				
D7H XR (CB)	79Z (E. Peoria) 4AB (Sagami)	92-96	171/230	25 193 (55,551)	1.98 (6'6") 3.9 (12'10")	4.74 (15'6") 3.5 (11'6")	PS	3.5 (2.2)	6.2 (3.8)	10.6 (6.6)				
D7H XR (DS)	5BF (E. Peoria) 2RG (Sagami)	92-96	171/230	25 492 (56,211)	1.98 (6'6") 3.9 (12'10")	4.74 (15'6") 3.5 (11'6")	PS	3.5 (2.2)	6.2 (3.8)	10.6 (6.6)				
D7H	77Z	85-86	215	19 680 (43,380)	1.98 (6'6") 2.54 (8'5")	4.73 (15'6") 4.619 (15'2")	DD	16 834 (37,113)	12 861 (28,353)	9703 (21,390)	7436 (16,394)	5522 (12,173)	3940 (8686)	
D7H (US)	79Z*	85-90	215/—	23 647 (52,134)	1.981 (6'6") 2.869 (9'5")	4.619 (15'2") 3.421 (11'3")	PS	2.7 (1.7)	3.5 (2.2)	4.5 (2.8)	5.8 (3.6)	7.6 (4.7)	10.0 (6.2)	
								3.9 (2.4)	6.8 (4.2)	11.9 (7.4)				

*D7H models prior to Series II. Product identification number prefix still in use for current product.

NOTE: Power Shift models show speeds only, not drawbar pull.

NOTE: Track-Type Tractor weights do not include blades until 1967.

Track-Type Tractors (cont'd)

Model	Product Ident. No. Prefix	Years Built	Horse-power FW/ Drawbar	Approx. Machine Weight kg (lb)	Gauge m (ft) and Width m (ft)	Length m (ft) and Height m (ft)	Transmission	Rated Drawbar Pull — kg (lb) and Forward Speed — km/h (mph)					
								1st	2nd	3rd	4th	5th	6th
								D7H (US)	77Z	85-90	215/—	23 570 (51,960)	1.981 (6'6")
D7H (US)	5BF*	88-90	215/—	24 351 (53,683)	1.981 (6'6")	4.624 (15'2")	PS/DS	2.7 (1.7)	3.5 (2.2)	4.6 (2.8)	5.8 (3.6)	7.6 (4.7)	10.0 (6.2)
D7H (JPN)	4AB*	86-90	215/—	23 647 (52,134)	1.981 (6'6")	4.619 (15'2")	PS	2.869 (9'5")	3.421 (11'3")	4.6 (2.8)	5.8 (3.6)	7.6 (4.7)	10.0 (6.2)
D7H (JPN)	2SB*	86-91	215/—	23 570 (51,960)	1.981 (6'6")	4.619 (15'2")	DD	16 834 (37,113)	12 861 (28,353)	9703 (21,390)	7436 (16,394)	5522 (12,173)	3940 (8686)
D7H (JPN)	2RG*	88-90	215/—	24 351 (53,683)	1.981 (6'6")	4.624 (15'2")	PS/DS	2.7 (1.7)	3.5 (2.2)	4.6 (2.8)	5.8 (3.6)	7.6 (4.7)	10.0 (6.2)
D7R LGP (JPN)	6ER	96-02	179 (240)	30 605 (67,472)	2.24 (7'4")	5.8 (19'0")	PS/DS	3.5 (2.3)	6.4 (4.0)	10.8 (6.8)			
D7H LGP (JPN)	5WB*	86-90	215/—	25 237 (55,638)	2.235 (7'4")	4.619 (15'2")	PS	3.9 (2.4)	6.8 (4.2)	11.9 (7.4)			
D7H LGP (JPN)	82Z*	86-91	215/—	25 445 (56,096)	2.235 (7'4")	4.619 (15'2")	DD	16 834 (37,113)	12 861 (28,353)	9703 (21,390)	7436 (16,394)	5522 (12,173)	3940 (8686)
D7H LGP (JPN)	3XG*	88-90	230/—	25 894 (57,086)	2.235 (7'4")	4.624 (15'2")	PS/DS	2.7 (1.7)	3.5 (2.2)	4.6 (2.8)	5.8 (3.6)	7.6 (4.7)	10.0 (6.2)
D7R STD (US)	2HR	95-01	171 (230)	27 413 (60,436)	2.0 (6'6")	6.04 (19'9")	PS/FTC	3.5 (2.3)	6.4 (4.0)	10.8 (6.8)			
D7R STD (US)	3ZR	96-02	171 (230)	27 413 (60,436)	2.0 (6'6")	6.04 (19'9")	PS/FTC	3.5 (2.3)	6.4 (4.0)	10.8 (6.8)			
D7R SII STD (JAPAN)	BRM	02-12	179/240	25 455 (56,129)	1.98 (6'6")**	2.87 (9'5")†	PS	3.52 (2.19)	6.10 (3.79)	10.54 (6.55)			
D7R SII STD (US)	AEC	00-10	179/240	25 455 (56,129)	1.98 (6'6")**	2.87 (9'5")†	PS	3.52 (2.19)	6.10 (3.79)	10.54 (6.55)			
D7R XR (US)	2EN	95-01	171 (230)	27 776 (61,236)	2.0 (6'6")	6.04 (19'9")	PS/DS	3.5 (2.3)	6.4 (4.0)	10.8 (6.8)			
D7R XR (US)	5MR	97-02	171 (230)	27 776 (61,236)	2.0 (6'6")	6.04 (19'9")	PS/DS	3.5 (2.3)	6.4 (4.0)	10.8 (6.8)			
D7R SII XR (JAPAN)	BPT	03-12	179/240	27 002 (59,540)	1.98 (6'6")**	3.05 (10'0")†	PS	3.52 (2.19)	6.10 (3.79)	10.54 (6.55)			
D7R SII XR (US)	AGN	00-10	179/240	27 002 (59,540)	1.98 (6'6")**	3.05 (10'0")†	PS	3.52 (2.19)	6.10 (3.79)	10.54 (6.55)			
D7H LGP (US)	80Z*	85-90	215/—	25 237 (55,638)	2.235 (7'4")	4.619 (15'2")	PS	3.9 (2.4)	6.8 (4.2)	11.9 (7.4)			

*D7H models prior to Series II. Product identification number prefix still in use for current product.

**D7R SII STD, XR and LGP machine width is for without trunnion.

†D7R SII STD, XR and LGP machine height is over EROPS, length is for basic machine.

NOTE: Power Shift models show speeds only, not drawbar pull.

NOTE: Track-Type Tractor weights do not include blades until 1967.

Track-Type Tractors (cont'd)

Model	Product Ident. No. Prefix	Years Built	Horse-power FW/ Drawbar	Approx. Machine Weight kg (lb)	Gauge m (ft) and Width m (ft)	Length m (ft) and Height m (ft)	Transmission	Rated Drawbar Pull — kg (lb) and Forward Speed — km/h (mph)						Remarks	
								1st	2nd	3rd	4th	5th	6th		
D7R LGP	4SR	96-02	179 (240)	29 500 (65,036)	2.24 (7'4")	5.8 (19'0")	PS/FTC	3.5 (2.3)	6.4 (4.0)	10.8 (6.8)					
D7H LGP (US)	4FG*	87-90	230/—	25 894 (57,086)	2.235 (7'4")	4.624 (15'2")	PS/DS								
D7R LGP (US)	3DN	95-01	179 (240)	30 605 (67,472)	2.24 (7'4")	5.8 (19'0")	PS/DS	3.7 (2.3)	6.4 (4.0)	11.1 (6.9)					
D7R LGP (US)	9HM	95-01	179 (240)	29 500 (65,036)	2.24 (7'4")	5.8 (19'0")	PS/FTC	3.5 (2.3)	6.4 (4.0)	10.8 (6.8)					
D7E	MDB	10-11	175 (235)	25 700 (56,669)	1.98 (6'6")	4.88 (16'0")	ED**								
D7R SII LGP	BNX	01-12	179/240	27 626 (60,916)	2.24 (7'4")†	3.16 (10'5")††	PS	3.52 (2.19)	6.10 (3.79)	10.54 (6.55)					
D7R SII LGP	ABJ	00-10	179/240	27 626 (60,916)	2.24 (7'4")†	3.16 (10'5")††	PS	3.52 (2.19)	6.10 (3.79)	10.54 (6.55)					
D7E LGP	SCG	10-11	175 (235)	28 170 (62,115)	2.29 (7'6")	4.88 (16'0")	ED**								
D8	1H	35-41	110/95	14 790 (32,600)	1.98 (6'6")	4.64 (15'3")	•	9680 (21,350)	6870 (15,150)	5720 (12,610)	4800 (10,590)	3860 (8520)	2740 (6050)		
D8	8R	41-45	131/113	15 490 (34,160)	2.64 (8'8")	2.28 (7'6")	••	2.7 (1.7)	3.8 (2.4)	4.5 (2.8)	5.1 (3.2)	6.3 (3.9)	8.5 (5.3)	RD-8 with 192 cm (78") gauge	
D8	2U	45-53	148/130	16 470 (36,310)	1.98 (6'6")	4.85 (15'10")	DD	13 060 (29,900)	9750 (21,700)	7940 (17,500)	6800 (15,000)	5620 (12,400)	3990 (8800)	Horsepower Increase	
D8	13A	53-55	185/150	16 866 (37,150)	2.64 (8'8")	2.18 (7'2")	DD	2.5 (1.6)	3.7 (2.3)	4.6 (2.9)	5.9 (3.7)	7.7 (4.8)		HP increase, DD transmission	
D8D, G	15A	55-57	191/155	16 310 (35,925)	1.98 (6'6")	5.23 (17'2")	TC	20 358 (44,840)	12 939 (28,500)	8926 (19,660)	6955 (15,320)	4935 (10,870)			
D8E, F	14A	55-57	191/155 Belt	17 734 (39,060)	2.64 (8'8")	2.26 (7'6")	DD	3.1 (1.9)	4.3 (2.7)	5.6 (3.5)	7.2 (4.5)	9.3 (5.8)			
D8H	35A	59-61	235	20 924 (46,032)	2.13 (7'0")	5.20 (17'1")	TC	5.8 (3.6)	8.5 (5.3)	11.9 (7.4)					
					2.87 (9'1")	2.39 (7'10")		20 439 (45,020)	16 135 (35,540)	10 964 (24,150)	7373 (16,240)	4953 (10,910)			
								2.4 (1.5)	3.1 (1.9)	4.5 (2.8)	6.1 (3.8)	8.3 (5.2)			
								5.6 (3.5)	8.2 (5.1)	12.2 (7.6)					

*D7H models prior to Series II. Product identification number prefix still in use for current product.

**Electric drive machines do not have transmission gears.

†D7R SII STD, XR and LGP machine width is for without trunnion.

††D7R SII STD, XR and LGP machine height is over EROPS, length is for basic machine.

• Power transmitted through dry tape flywheel clutch to selective type hinge speed gear set.

•• Power transmitted through flexible and over center engagement, dry flywheel clutch with metallic friction surfaces. Selective type change speed gear set.

NOTE: Power Shift models show speeds only, not drawbar pull.

NOTE: Track-Type Tractor weights do not include blades until 1967.

Track-Type Tractors (cont'd)

Model	Product Ident. No. Prefix	Years Built	Horse-power FW/ Drawbar	Approx. Machine Weight kg (lb)	Gauge m (ft) and Width m (ft)	Length m (ft) and Height m (ft)	Transmission	Rated Drawbar Pull — kg (lb) and Forward Speed — km/h (mph)						Remarks
								1st	2nd	3rd	4th	5th	6th	
D8H	36A	58-66	235/185	21 400 (47,180)	2.13 (7'0")	5.20 (17'1")	DD	19 958 (44,400)	15 648 (34,500)	10 931 (24,100)	8051 (17,750)	5869 (13,000)	3832 (8450)	
D8H	46A	58-74	270	21 863 (48,210)	2.87 (9'1")	2.39 (7'10")	PS	2.4 (1.5)	3.0 (1.9)	4.3 (2.7)	5.6 (3.5)	7.4 (4.6)	10.1 (6.3)	
D8K	76V	74-82	300	31 980 (69,300)*	2.13 (7'0")	5.26 (17'3")	DD	25 400 (56,000)	18 930 (41,740)	12 990 (28,640)	9370 (20,650)	6610 (14,580)	4090 (9010)	Turbocharged, Sealed and Lubricated Track
D8K	77V	74-82	300	31 430 (70,500)†	2.13 (7'0")	5.26 (17'3")	PS	2.7 (1.7)	3.5 (2.2)	4.8 (3.0)	6.3 (3.9)	8.2 (5.1)	11.3 (7.0)	Turbocharged, Sealed and Lubricated Track
D8L	53Y 7JC 7YB	82-86 84-90 85-92	335	37 305 (82,243)	2.2 (7'3")	4.95 (16'2")	PS	3.9 (2.4)	6.8 (4.2)	11.9 (7.4)				
D8L SA	4FB	84-87	400/325	36 650 (80,820)	2.54 (8'4")	3.11 (10'3")	DD	31 679 (69,840)	23 115 (50,960)	17 196 (37,910)	12 388 (27,310)	9154 (20,180)	6428 (14,170)	
D8N	9TC 5TJ	87-92 92-95	285	37 462 (82,590)	2.08 (6'10")	4.95 (16'3")	PS	3.05 (2.2)	3.43 (3.9)	10.8 (6.7)				
D8R Series II (US)	6YZ	00-04	310	37 830 (83,400)	2.08 (6'10")	6.91 (22'8")	PS	3.05 (2.1)	3.51 (3.7)	10.6 (6.6)				
D8R Series II (BRAZIL)	AKA	2000	231/310	37 830 (83,400)	2.08 (6'10")	6.91 (22'8")	PS	3.05 (2.1)	3.51 (3.7)	10.6 (6.6)				
D8T**	MLN-FTC	11-14	271	39 420 (86,900)	2.08 (6'10")	4.55 (14'7")	PS/DS	67 414 (148,621)	37 025 (81,628)	20 139 (44,399)				
D8T LGP**	MLN-FTC	11-14	271	37 420 (82,496)	3.06 (10'1")	3.5 (11'6")	PS/DS	3.4 (2.1)	6.1 (3.8)	10.6 (6.6)				

*Approximate operating weight. Includes lubricants, coolant, full fuel tank, hydraulic control, 8S Bulldozer, ROPS canopy and operator.

All other weights listed in this column are shipping weights.

**Meets Tier 4 Interim/Stage IIIB/Japan 2011 (Tier 4 Interim) emission standards.

†Power transmitted through dry tape flywheel clutch to selective type hinge speed gear set.

NOTE: Power Shift models show speeds only, not drawbar pull.

NOTE: Track-Type Tractor weights do not include blades until 1967.

Track-Type Tractors (cont'd)

Model	Product Ident. No. Prefix	Years Built	Horse-power FW/ Drawbar	Approx. Machine Weight kg (lb)	Gauge m (ft) and Width m (ft)	Length m (ft) and Height m (ft)	Transmission	Rated Drawbar Pull — kg (lb) and Forward Speed — km/h (mph)					
								1st	2nd	3rd	4th	5th	6th
D9D	18A	55-56	286/230	25 772 (56,765)	2.29 (7'6") 3.03 (10'0")	5.46 (17'11") 2.67 (8'9")	DD	27 631 (60,860)	21 207 (46,710)	15 423 (33,970)	10 706 (23,580)	7658 (16,670)	4958 (10,920)
D9D	18A	56-59	320/260	26 125 (57,543)	2.29 (7'6") 3.03 (10'0")	5.46 (17'11") 2.67 (8'9")	DD	28 603 (63,000)	23 835 (52,500)	16 617 (36,600)	12 167 (26,800)	9171 (20,200)	6106 (13,450)
D9D	19A	55-56	286/230	25 729 (56,670)	2.29 (7'6") 3.03 (10'0")	5.46 (17'11") 2.67 (8'9")	TC				6.6 (4.1)	9.0 (5.6)	12.6 (7.8)
D9D	19A	56-59	320/260	26 238 (57,990)	2.29 (7'6") 3.03 (10'0")	5.46 (17'11") 2.68 (8'9")	TC				6.6 (4.1)	9.5 (5.9)	13.0 (8.1)
D9E	50A	59-60	335	27 016 (59,506)	2.29 (7'6") 3.03 (10'0")	5.50 (18'1") 2.70 (8'11")	TC						
D9D	34A	59-61	335	27 167 (59,837)	2.29 (7'6") 3.03 (10'0")	5.50 (18'1") 2.70 (8'11")	PS						
D9E	49A	59-60	335/268	26 957 (59,375)	2.29 (7'6") 3.03 (10'0")	5.50 (18'1") 2.70 (8'11")	DD						
D9G	66A	61-74	385	31 072 (68,500)	2.29 (7'6") 3.10 (10'0")	5.50 (18'1") 2.10 (8'7")	PS						
								2.7 (1.7)	3.5 (2.2)	4.8 (3.0)	6.4 (4.0)	8.2 (5.1)	11.4 (7.1)
								3.9 (2.4)	6.8 (4.2)	10.5 (6.5)			

NOTE: Power Shift models show speeds only, not drawbar pull.

NOTE: Track-Type Tractor weights do not include blades until 1967.

Track-Type Tractors (cont'd)

Model	Product Ident. No. Prefix	Years Built	Horsepower FW/ Drawbar	Approx. Machine Weight kg (lb)	Gauge m (ft) and Width m (ft)	Length m (ft) and Height m (ft)	Transmission	Rated Drawbar Pull — kg (lb) and Forward Speed — km/h (mph)						Remarks
								1st	2nd	3rd	4th	5th	6th	
S × S D9G	29N	69-74	770	86 200* (190,000)	5.8* (19'0")	8.0◀ (25'0")	PS							L.H. of S × S D9G
	30N				7.3** (24'0")	2.8◀◀ (9'2")		3.9 (2.4)	6.8 (4.2)	10.0 (6.2)	R.H. of S × S D9G			
Dual D9G	90J	69-74	770	79 470* (175,200)	2.3* (7'6")	12.9◀ (42'6")	PS							Front of Dual D9G
	91J				3.3** (10'9")	3.1◀◀ (9'11")		3.9 (2.4)	6.8 (4.2)	10.5 (6.5)	Rear of Dual D9G			
S × S D9H	99V	74-77	820	83 400* (183,900)	5.8* (19'0")	9.0◀ (26'1")	PS							L.H. of S × S D9H
	12U				7.3** (24'0")	2.9◀◀ (9'6")		4.0 (2.5)	6.9 (4.3)	10.8 (6.7)	R.H. of S × S D9H			
Dual D9H	97V	74-80	820	81 100* (178,800)	2.3* (7'6")	12.9◀ (42'6")	PS							Front of Dual D9H
	98V				3.3** (10'9")	3.1◀◀ (9'11")		4.0 (2.5)	6.9 (4.3)	10.8 (6.7)	Rear of Dual D9H			
D9H	90V	74-81	410	32 840 (72,400)	2.3* (7'6")	5.6 (18'5")	PS							Standard Model
	D9L				3.0 (9'11")	2.7◀◀ (8'10")		4.0 (2.5)	6.9 (4.3)	10.8 (6.7)				
D9N	14Y	80-87	460	52 055 (114,656)	2.5 (8'2")	5.32 (17'5")	PS							
	1JD				3.11 (10'2")	4.41 (14'6")		3.9 (2.4)	7.2 (4.5)	12.4 (7.7)				
D9R (CB) (US)	ACL	00-04	410	49 147 (108,350)	2.55 (7'5")	5.17 (16'11.5")	PS							
	6XJ				2.43 (9'7")	3.91 (12'10")		3.9 (2.4)	6.9 (4.3)	12.1 (7.5)				
D9R (DS) (US)	ABK	00-04	410	49 510 (109,150)	2.25 (7'5")	6.84 (22'5")	PS							
	D9T				3.30 (10'10")	3.99 (13'1")		3.8 (2.4)	6.8 (4.2)	11.9 (7.4)				
D9T	RJS	04-11	410	47 900 (105,600)	2.25 (7'5")	6.85 (22'6")	PS							
					3.31 (10'11")	3.99 (13'1")		3.9 (2.4)	6.8 (4.2)	11.7 (7.3)				

*Gauge of both tractors combined.

**Width to outside of dozer blade.

*Approximate weight of both machines plus Bulldozer, hydraulic controls, coolant and 5% fuel. (D10, D11N, D11R includes SS ripper)

NOTE: Power Shift models show speeds only, not drawbar pull.

NOTE: Track-Type Tractor weights do not include blades until 1967.

◀ Length including dozer blade.

◀◀ Overall height excluding stack and canopy.

Track-Type Tractors (cont'd)

Model	Product Ident. No. Prefix	Years Built	Horse-power FW/ Drawbar	Approx. Machine Weight kg (lb)	Gauge m (ft) and Width m (ft)	Length m (ft) and Height m (ft)	Transmission	Rated Drawbar Pull — kg (lb) and Forward Speed — km/h (mph)						Remarks
								1st	2nd	3rd	4th	5th	6th	
D10	84W	78-86	700	88 245 (194,140)	2.9 (9'6")	5.92 (19'8")	PS							
	76X													
D10N	2YD	87-93	520	66 400 (147,405)	2.55 (8'4")	5.89 (18'4")	PS							
	3SK	93-96	3.30 (10'10")	4.45 (14'7")	4.0 (2.5)	7.1 (4.4)								
D10R	3KR	95-02	570	65 764 (144,986)	2.55 (8'4")	7.50 (24'7")	TD 3-Spd PS							3412 DITA HEUI™
D10R	AKT	01-04	580	65 400 (144,200)	3.72 (12'2")	3.27 (10'9")								
D10T	RJG	05-14	580	70 171 (154,700)	2.55 (8'4")	7.42 (24'4")	TD 3-Spd PS							C27 ACERT™ DITA MEUI™
				3.74 (12'3")	3.22 (10'7")	4.0 (2.5)								
D11N	74Z	86-93	770	95 900 (211,000)	2.90 (9'6")	6.16 (20'3")	PS							
	4HK	93-96	97 450 (214,850)	3.65 (12'0")	4.65 (15'3")	3.9 (2.4)								
D11R	8ZR	96-97	770	98 413 (216,963)	2.89 (9'6")	6.16 (20'3")	PS							
				3.60 (11'10")	4.65 (15'3")	3.9 (2.4)								
D11R	9TR	97-99	850	104 590 (230,100)	2.89 (9'6")	6.16 (20'3")	PS							
				3.60 (11'10")	4.65 (15'3")	3.9 (2.4)								
D11R	7PZ	00-07	850	104 600 (230,100)	2.89 (9'6")	5.21 (17'1")	PS							
				3.60 (11'10")	4.57 (15'0")	3.9 (2.4)								
D11R CD	9XR	96-99	850	111 590 (246,000)	2.89 (9'6")	6.16 (20'3")	PS							
				3.60 (11'10")	4.65 (15'3")	3.9 (2.4)								
D11R CD	AAF	96-07	850	113 000 (248,600)	2.89 (9'6")	5.21 (17'1")	PS							
				3.81 (12'6")	4.57 (15'0")	3.9 (2.4)								
D11T	GEB	07-11	850	104 590 (230,581)	2.89 (9'6")	8.64 (28'4")	TD 3-Spd PS							C32 ACERT DITA MEUI
				4.38 (14'4")	3.64 (11'11")	3.9 (2.4)								
D11T CD	TPB	07-11	850	113 000 (249,122)	2.89 (9'6")	8.77 (28'9")	TD 3-Spd PS							C32 ACERT DITA MEUI
				4.38 (14'4")	3.64 (11'11")	3.9 (2.4)								

◀ Overall height excluding stack and canopy.
 NOTE: Power Shift models show speeds only, not drawbar pull.
 NOTE: Track-Type Tractor weights do not include blades until 1967.

Former Models

Track-Type Tractors

- Manufactured Outside U.S.A.

TRACK-TYPE TRACTORS MANUFACTURED OUTSIDE U.S.A.

Source	Model	Product Ident. No. Prefix	Years Built	Horsepower Flywheel/ Drawbar	Transmission	Gauge m (ft)
U.K.	D4C	24A	60-64	63/50	DD	1.52 (5'0")
	D4D	88A	64-67	65/52	DD	1.52 (5'0")
	D6C	82A	64-68	120/93	DD	1.88 (6'2")
	D6C	83A	64-68	120/—	PS	1.88 (6'2")
	D6C	46J	71-77	140/—	DD	1.88 (6'2")
	D6C	47J	71-77	140/—	PS	1.88 (6'2")
	D8H	52A	59-61	235/—	PS	2.13 (7'0")
	D8H	22A	59-66	235/185	DD	2.13 (7'0")
	D8H	68A	60-66	235/—	PS	2.13 (7'0")
D8K	66V	74-82	300/—	PS	2.13 (7'0")	
Brazil	D4D	97F	69-78	75/—	DD	1.52 (5'0")
	D4D	74U	71-78	75/—	PS	1.52 (5'0")
	D6C	24U	71-77	120/93	PS	1.88 (6'2")
	D6C	23U	73-77	120/93	DD	1.88 (6'2")
	D6D	74W	77-92	140/—	DD	1.88 (6'2")
	D6D	75W	77-92	140/—	PS	1.88 (6'2")
	D6D	9FK	92-96	140/—	PS	1.88 (6'2")
	D6E	2MJ	92-96	155/—	PS	1.88 (6'2")
	D6D	19B	85-91	140/—	PS	1.88 (6'2")
	D6G	2MJ	89-03	160/—	PS	1.88 (6'2")
	D6G SR	3SR	97-01	160/—	PS	1.88 (6'2")
	D6M XL	5WR	96-02	104/140	PS	1.89 (6'2")
	D6M XL	6LR	96-02	104/140	PS	1.89 (6'2")
	D8L	7JC	84-90	335/—	PS	2.2 (7'3")
	D8L	7YB	85-92	335/—	PS	2.2 (7'3")
	D8N	7TK	93-95	285/—	PS	2.08 (6'10")
D8R	9EM	95-	305/—			
D8R Series II	AKA	00-04	310	PS	2.08 (6'10")	
D8R Series II	AKA	00-04	310	PS	3.05 (10'0")	
Australia	D4	29A	59-61	63/50	DD	1.12 (3'8")
	D4	30A	59-60	63/50	DD	1.52 (5'0")
	D4C	54A	60-62	63/52	DD	1.12 (3'8")
	D4C	55A	60-62	65/52	DD	1.52 (5'0")
	D4D	85A	63-68	65/52	DD	1.52 (5'0")
	D5	51H	68-68	93/75	DD	1.88 (6'2")
	D5	52H	68-69	93/—	PS	1.88 (6'2")
	D6	31A	58-60	93/75	DD	1.52 (5'0")
	D6	32A	58-60	93/75	DD	1.18 (6'2")
	D6B	56A	60-66	90/73	DD	1.52 (5'0")
	D6B	57A	60-68	90/73	DD	1.88 (6'2")
	D6C	71A	63-68	120/93	DD	1.88 (6'2")
	D6C	73A	63-68	120/—	PS	1.88 (6'2")
	D6C	55J	69-72	125/—	DD	1.88 (6'2")
D6C	56J	69-72	125/—	PS	1.88 (6'2")	
China	D6G Series 2	C6G	06-11	160	PS	1.88 (6'2")
	D6G Series 2 LGP	C6X	08-11	160/—	PS	2.11 (6'11")
	D7G Series 2	C7G	06-11	200	PS	1.98 (6'6")
	D7G Series 2	C7G	04-11	149/200	PS	1.98 (6'6")
Indonesia	D6G Series 2	P6G	06-11	160/—	PS	1.88 (6'2")
	D7G	7MB	83-11	202/—	PS	1.98 (6'6")
	D7G Series 2	7MB	83-12	149/200	PS	1.98 (6'6")
France	D4C	69A	61-63	63/50	DD	1.52 (5'0")
	D4D	86A	63-68	65/52	DD	1.52 (5'0")
	D4D LGP	18J	66-68	65/52	DD	1.79 (5'10")
	D4D	58J	67-68	65/—	PS	1.52 (5'0")

Track-Type Tractors Manufactured Outside U.S.A. (cont'd)

Source	Model	Product Ident. No. Prefix	Years Built	Horsepower Flywheel/ Drawbar	Transmission	Gauge m (ft)
France (cont'd)	D4E	68X	78-86	80/—	DD	1.52 (5'0")
	D4E	69X	78-85	80/—	PS	1.52 (5'0")
	D4E LGP	71X	78-85	80/—	DD	1.77 (5'10")
	D4E LGP	72X	78-86	80/—	PS	1.77 (5'10")
	D5	62J	69-77	105/—	DD	1.88 (6'2")
	D5	63J	69-77	105/—	PS	1.88 (6'2")
	D5 LGP	6R	70-77	105/—	PS	2.06 (6'9")
	D5 LGP	12R	70-77	105/—	DD	2.06 (6'9")
	D5B	43X	77-85	105/—	DD	1.88 (6'2")
	D5B	44X	77-86	105/—	PS	1.88 (6'2")
	D5B LGP	45X	77-86	105/—	DD	2.06 (6'9")
	D5B LGP	46X	77-86	105/—	PS	2.06 (6'9")
	D5B	8MB	84-86	105/—	PS	1.52 (5'0")
	D5H	8RC	85-96	120/—	PS	1.80 (5'11")
	D5H LGP	1DD	86-96	130/—	PS	2.16 (7'1")
	D5H XL	8RJ	86-96	130/—	PS	1.89 (6'2")
	D5H	7NC	85-96	120/—	DD	1.80 (5'11")
	D5H LGP	9HC	85-96	130/—	DD	2.16 (7'1")
	D5M XL	4BR	96-02	82/110	PS	1.77 (5'10")
	D5M XL	6GN	96-02	82/110	PS	1.77 (5'10")
	D5M LGP	3DR	96-02	82/110	PS	2.00 (6'7")
	D5M LGP	3CR	96-02	82/110	PS	2.00 (6'7")
	D6M XL	9ZM	96-02	104/140	PS	1.89 (6'2")
D6M XL	3WN	96-02	104/140	PS	1.89 (6'2")	
D6M LGP	2RN	96-02	104/140	PS	2.16 (7'1")	
D6M LGP	4JN	96-02	104/140	PS	2.16 (7'1")	
Scotland	D6D	19X	78-86	140/—	DD	1.88 (6'2")
	D6D	20X	78-86	140/—	PS	1.88 (6'2")
	D6D	0IY	79-87	125/—	PS	1.88 (6'2")
Glasgow	D6H	7PC	86-87	165/—	PS	1.88 (6'2")
	D6H LGP	8YC	86-87	165/—	PS	2.23 (7'4")
Japan	D3	79U	73-79	62/—	PS	1.42 (4'8")
	D3	82U	73-78	62/—	PS	1.42 (4'8")
	D3 LGP	6N	73-79	62/—	PS	1.65 (5'5")
	D3 LGP	83U	73-79	62/—	PS	1.65 (5'5")
	D3B	23Y	79-87	65/—	PS	1.42 (4'8")
	D3B LGP	24Y	79-87	65/—	PS	1.65 (5'5")
	D3B	27Y	79-87	65/—	PS	1.42 (4'8")
	D3B LGP	28Y	79-87	65/—	PS	1.65 (5'5")
	D3B	3YC	85-87	65/—	DD	1.42 (4'8")
	D3B LGP	5MC	85-87	65/—	DD	1.65 (5'5")
	D3C	5KG	87-90	67/—	PS	1.42 (4'7")
	D3C Series II	7JG/4HJ	90-93	70/—	PS	1.42 (4'7")
	D3C LGP	1PJ	87-90	67/—	PS	1.65 (5'4")
	D3C LGP Series II	8GD/5CJ	90-93	70/—	PS	1.65 (5'4")
	D3G XL	CFC	01-03	70	HYS	1.45 (4'9")
	D3G XL*	JMH	03-07	70	HYS	1.45 (4'9")
	D3G LGP	CFF	01-03	70	HYS	1.68 (5'6")
	D3G LGP*	BYR	03-07	70	HYS	1.68 (5'6")
	D4D LGP	67A	65-68	65/52	DD	1.79 (5'10")
	D4D	91A	65-68	65/52	DD	1.52 (5'0")
	D4E	50X	77-86	80/—	DD	1.52 (5'0")
	D4E	51X	77-86	80/—	PS	1.52 (5'0")
	D4E LGP	52X	77-86	80/—	DD	1.77 (5'10")
D4C	1RJ	87-90	78/—	PS	1.42 (4'7")	
D4C Series II	7KG	90-93	80/—	PS	1.42 (4'7")	

*Meets Tier 2/Stage II/Japan 2001 (Tier 2) equivalent emission standards.

Track-Type Tractors Manufactured Outside U.S.A. (cont'd)

Source	Model	Product Ident. No. Prefix	Years Built	Horsepower Flywheel/ Drawbar	Transmission	Gauge m (ft)
Japan (cont'd)	D4C LGP	2CJ	87-90	78/—	PS	1.65 (5'4")
	D4C LGP Series II	98G	90-93	80/—	PS	1.65 (5'4")
	D4G XL	CFN	01-03	80	HYS	1.50 (4'11")
	D4GXL*	HYD	03-07	80	HYS	1.50 (4'11")
	D4G LGP	FDC	01-03	80	HYS	1.68 (5'6")
	D4G LGP*	TLX	03-07	80	HYS	1.68 (5'6")
	D4H	8PB	85-96	90/95	PS	1.67 (5'5")
	D4H LGP	9DB	85-96	105/—	PS	2.0 (6'7")
	D4H	2AC	85-92	90/95	DD	1.67 (5'5")
	D4H LGP	3AC	85-90	90/95	DD	2.0 (6'7")
	D4H XL	8PJ	92-96	105/—	PS	1.77 (5'10")
	D4H LGP	9GJ	92-96	105/—	PS	2.0 (6'7")
	D4H LGP	4NK	92-93	105/—	DD	2.0 (6'7")
	D5	37J	67-68	93/75	DD	1.88 (6'2")
	D5 LGP	98A	67-68	93/75	DD	2.06 (6'9")
	D5	67J	68-77	105/—	DD	1.88 (6'2")
	D5	97J	71-76	105/—	PS	1.88 (6'2")
	D5 LGP	68J	68-77	105/—	DD	2.06 (6'9")
	D5B	47X	77-86	105/—	DD	1.88 (6'2")
	D5B	48X	77-86	105/—	PS	1.88 (6'2")
	D5B LGP	49X	77-86	105/—	DD	2.06 (6'9")
	D5C	6PJ	91-93	90/—	PS	1.54 (5'1")
	D5C LGP	3MK	91-93	90/—	PS	1.72 (5'8")
	D5G XL	FDH	01-03	90	HYS	1.55 (5'1")
	D5GXL*	WGB	03-07	90	HYS	1.55 (5'1")
	D5G LGP	FDW	01-03	90	HYS	1.73 (5'8")
	D5G LGP*	RKG	03-07	90	HYS	1.73 (5'8")
	D5H	3MD	86-96	120/—	PS	1.80 (5'11")
	D5H LGP	4KD	86-96	130/—	PS	2.16 (7'1")
	D5H	1YD	86-96	120/—	DD	1.80 (5'11")
	D5H LGP	2SD	86-96	130/—	DD	2.16 (7'1")
	D5M XL	4JS	96-	82/110	PS	1.77 (5'10")
	D5M XL	5ES	96-02	82/110	PS	1.77 (5'10")
	D5M LGP	5FS	96-	82/110	PS	2.00 (6'7")
	D5M LGP	6AS	96-02	82/110	PS	2.00 (6'7")
	D5M LGP	7LR	97-02	78/105	DDPS	2.00 (6'7")
	D6B	37H	66-67	93/75	DD	1.88 (6'2")
	D6B LGP	38H	66-67	93/75	DD	2.06 (6'9")
	D6C	41A	66-68	120/93	DD	1.88 (6'2")
	D6C	96A	66-68	120/93	PS	1.88 (6'2")
	D6C	26K	68-77	125/—	DD	1.88 (6'2")
	D6C	69C	68-77	125/—	PS	1.88 (6'2")
	D6C LGP	90B	71-77	140/—	DD	2.11 (6'11")
	D6D LGP LS	6HC	86-96	160/—	DD	1.88 (6'2")
	D6D	31X	86-98	140/—	PS	1.88 (6'2")
	D6D	30X	85-96	140/—	DD	1.88 (6'2")
	D6D PTNR	5YB	88-96	160/—	PS	1.88 (6'2")
	D6G	BWJ	02-07	160/—	PS	1.88 (6'2")
	D6M XL	2YS	96-	104/140	PS	1.89 (6'2")
	D6M XL	4HS	96-02	104/140	PS	1.89 (6'2")
	D6M LGP	4GS	96-	104/140	PS	2.16 (7'1")
	D6M LGP	5NR	96-02	104/140	PS	2.16 (7'1")

*Meets Tier 2/Stage II/Japan 2001 (Tier 2) equivalent emission standards.

Track-Type Tractors Manufactured Outside U.S.A. (cont'd)

Source	Model	Product Ident. No. Prefix	Years Built	Horsepower Flywheel/ Drawbar	Transmission	Gauge m (ft)	
Japan (cont'd)	D6R	S6X	10-	175	PS	1.88 (74")	
	D6R XL	S6T	10-	195	PS	1.88 (74")	
	D6R LGP	S6Y	10-	195	PS	2.286 (90")	
	D6R SIII	JEK	06-10	138/185	PS	1.88 (6'2")	
	D6R SIII XL	EXL	06-12	149/200	PS	1.88 (6'2")	
	D6R SIII XW	EXW	07-09	149/200	PS	2.03 (6'8")	
	D6R SIII LGP	LGP	06-12	149/200	PS	2.29 (7'6")	
	D7G	35N	80-91	202/—	PS	1.98 (6'6")	
	D7G LGP	44W	76-87	202/—	PS	1.98 (6'6")	
	D7G LGP	45W	75-86	202/—	DD	1.98 (6'6")	
	D7G	64V	75-88	202/—	DD	1.98 (6'6")	
	D7G	65V	75-07	202/—	PS	1.98 (6'6")	
	D7G	65V	75-07	149/200	PS	1.98 (6'6")	
	D7H	25B	85-92	215/—	DD	1.98 (6'6")	
							2.54 (8'5")
		D7H LGP	82Z	85-92	215/—	DD	2.23 (7'4")
							3.15 (10'4")
		D7R	DSH	12-	240	PS	1.98 (78")
		D7R XR	DJR	12-	240	PS	1.98 (78")
		D7R LGP	DLN	12-	240	PS	2.235 (88")
	D7R SII	BRM	02-12	179/240	PS	1.98 (6'6")	
	D7R SII XR	BPT	03-12	179/240	PS	1.98 (6'6")	
	D7R SII LGP	BNX	01-12	179/240	PS	2.24 (7'4")	



AGRICULTURAL TRACTORS

Model	Product Ident. No. Prefix	Years Built	Horse-power FW/ Drawbar	Approx. Machine Weight kg (lb)	Height m (ft) Gauge m (ft)	Drawbar Pull kg (lb)* and Forward Speed km/h (mph)							
						1st	2nd	3rd	4th	5th	6th	7th	8th
						Challenger 35	8DN	94-98	175/150	9838 - 12 133 (10'0")	3.05 (10'0")	8604 (18,968)	8499 (18,737)
Challenger 35	8RD	99-01	175/150	9838 - 12 133 (10'0")	3.05 (10'0")	8604 (18,968)	8499 (18,737)	8314 (18,329)	7851 (17,307)	7161 (15,787)	6694 (14,757)	5949 (13,116)	5147 (11,348)
Challenger 35	ADK	99-01	175/150	9838 - 12 133 (10'0")	3.05 (10'0")	8604 (18,968)	8499 (18,737)	8314 (18,329)	7851 (17,307)	7161 (15,787)	6694 (14,757)	5949 (13,116)	5147 (11,348)
Challenger MT735		01-02	235/185	9838 - 10 977 - 20 400 (24,200 - 45,000)	3.05 (10'0")	12 680 (27,900)	12 680 (27,900)	12 680 (27,900)	10 890 (23,950)	9130 (20,090)	8105 (17,830)	7187 (15,810)	6388 (14,050)
Challenger 45	1DR	94-98	200/170	9838 - 12 133 (10'0")	3.05 (10'0")	8675 (19,125)	8675 (19,125)	8675 (19,125)	8255 (18,199)	7710 (16,997)	7318 (16,134)	6757 (14,897)	5891 (12,987)
Challenger 45	ABF	99-01	200/170	9838 - 12 133 (10'0")	3.05 (10'0")	8675 (19,125)	8675 (19,125)	8675 (19,125)	8255 (18,199)	7710 (16,997)	7318 (16,134)	6757 (14,897)	5891 (12,987)
Challenger 45	3BK	99-01	200/170	9838 - 12 133 (10'0")	3.05 (10'0")	8675 (19,125)	8675 (19,125)	8675 (19,125)	8255 (18,199)	7710 (16,997)	7318 (16,134)	6757 (14,897)	5891 (12,987)
Challenger MT745		01-02	255/205	9838 - 10 977 - 20 400 (24,200 - 45,000)	3.05 (10'0")	12 680 (27,900)	12 680 (27,900)	12 680 (27,900)	11 828 (26,020)	9920 (21,820)	8806 (19,370)	7808 (17,180)	6941 (15,270)
Challenger 55	7DM	96-98	225/191	9838 - 12 133 (10'0")	3.05 (10'0")	8675 (19,125)	8675 (19,125)	8675 (19,125)	8255 (18,200)	7802 (17,200)	7188 (15,848)	6593 (14,535)	
Challenger 55	AEN	99-01	225/191	9838 - 12 133 (10'0")	3.05 (10'0")	8675 (19,125)	8675 (19,125)	8675 (19,125)	8255 (18,200)	7802 (17,200)	7188 (15,848)	6593 (14,535)	
Challenger 55	6NN	99-01	225/191	9838 - 12 133 (10'0")	3.05 (10'0")	8675 (19,125)	8675 (19,125)	8675 (19,125)	8255 (18,200)	7802 (17,200)	7188 (15,848)	6593 (14,535)	
Challenger MT755		01-02	290/235	10 097 - 20 400 (24,200 - 45,000)	3.37 (11'1")	12 682 (27,900)	12 682 (27,900)	12 682 (27,900)	12 682 (27,900)	11 302 (24,865)	10 032 (22,070)	8896 (19,570)	7908 (17,397)
Challenger MT765		01-02	306/255	10 977 - 20 411 (24,200 - 45,000)	3.37 (11'1")	12 682 (27,900)	12 682 (27,900)	12 682 (27,900)	12 682 (27,900)	11 894 (26,168)	10 558 (23,228)	9362 (20,597)	8322 (18,308)

*Base gauge (no spacers) of 1.47 m (60") available on 8DN1-849, 1DR1-1699, 7DM1-849. Base gauges (no spacers) of 1.47 m (60") and 2.03 m (80") available on 8DN850-Up, 1DR1700-Up, and 7DM850-Up.

Agricultural Tractors (cont'd)

Model	Product Ident. No. Prefix	Years Built	Horse-power FW/ Drawbar	Approx. Machine Weight kg (lb)	Height m (ft) Gauge m (ft)	Drawbar Pull kg (lb)* and Forward Speed km/h (mph)							
						9th	10th	11th	12th	13th	14th	15th	16th
Challenger 35	8DN	94-98	175/150	9838 -	3.05	4436	3740	3171	2601	2154	1771	1449	1196
				12 133	(10'0")	(9779)	(8244)	(6991)	(5735)	(4749)	(3904)	(3194)	(2637)
Challenger 35	8RD	99-01	175/150	9838 -	3.05	4436	3740	3171	2601	2154	1771	1449	1196
				12 133	(10'0")	(9779)	(8244)	(6991)	(5735)	(4749)	(3904)	(3194)	(2637)
Challenger 35	ADK	99-01	175/150	9838 -	3.05	4436	3740	3171	2601	2154	1771	1449	1196
				12 133	(10'0")	(9779)	(8244)	(6991)	(5735)	(4749)	(3904)	(3194)	(2637)
Challenger MT735		01-02	235/185	9838 -	3.05	4436	3740	3171	2601	2154	1771	1449	1196
				12 133	(10'0")	(9779)	(8244)	(6991)	(5735)	(4749)	(3904)	(3194)	(2637)
Challenger 45	1DR	94-98	200/170	9838 -	3.05	5063	4170	3547	2920	2427	2003	1646	1365
				12 133	(10'0")	(11,162)	(9193)	(7821)	(6438)	(5351)	(4416)	(3629)	(3010)
Challenger 45	ABF	99-01	200/170	9838 -	3.05	5063	4170	3547	2920	2427	2003	1646	1365
				12 133	(10'0")	(11,162)	(9193)	(7821)	(6438)	(5351)	(4416)	(3629)	(3010)
Challenger 45	3BK	99-01	200/170	9838 -	3.05	5063	4170	3547	2920	2427	2003	1646	1365
				12 133	(10'0")	(11,162)	(9193)	(7821)	(6438)	(5351)	(4416)	(3629)	(3010)
Challenger MT745		01-02	255/205	9838 -	3.05	5063	4170	3547	2920	2427	2003	1646	1365
				12 133	(10'0")	(11,162)	(9193)	(7821)	(6438)	(5351)	(4416)	(3629)	(3010)
Challenger 55	7DM	96-98	225/191	9838 -	3.05	5663	4676	3990	3295	2747	2275	1876	1562
				12 133	(10'0")	(12,484)	(10,310)	(8796)	(7264)	(6056)	(5015)	(4135)	(3443)
Challenger 55	AEN	99-01	225/191	9838 -	3.05	5663	4676	3990	3295	2747	2275	1876	1562
				12 133	(10'0")	(12,484)	(10,310)	(8796)	(7264)	(6056)	(5015)	(4135)	(3443)
Challenger 55	6NN	99-01	225/191	9838 -	3.05	5663	4676	3990	3295	2747	2275	1876	1562
				12 133	(10'0")	(12,484)	(10,310)	(8796)	(7264)	(6056)	(5015)	(4135)	(3443)
Challenger MT755		01-02	290/235	9838 -	3.05	5663	4676	3990	3295	2747	2275	1876	1562
				12 133	(10'0")	(12,484)	(10,310)	(8796)	(7264)	(6056)	(5015)	(4135)	(3443)
Challenger MT765		01-02	306/255	9838 -	3.05	5663	4676	3990	3295	2747	2275	1876	1562
				12 133	(10'0")	(12,484)	(10,310)	(8796)	(7264)	(6056)	(5015)	(4135)	(3443)

*Base gauge (no spacers) of 1.47 m (60") available on 8DN1-849, 1DR1-1699, 7DM1-849. Base gauges (no spacers) of 1.47 m (60") and 2.03 m (80") available on 8DN850-Up, 1DR1700-Up, and 7DM850-Up.

Agricultural Tractors (cont'd)

Model	Product Ident. No. Prefix	Years Built	Horse-power FW/ Drawbar	Approx. Machine Weight kg (lb)	Height m (ft) Gauge m (ft)	Drawbar Pull kg (lb)* and Forward Speed km/h (mph)									
						1st	2nd	3rd	4th	5th	6th	7th	8th	9th	10th
Challenger 65	7YC	86-90	270/200	14 061	3.24	14 825	10 393	8880	7701	6656	5708	4950	4245	2858	1725
				(31,000)	(10'8")	(32,684)	(22,912)	(19,577)	(16,978)	(14,674)	(12,583)	(10,912)	(9358)	(6300)	(3803)
					2.15	4.2	6.4	7.5	8.6	9.9	11.3	13.0	14.9	19.3	29.3
Challenger 65B	7YC	91-92	285/225	14 060	3.24	14 893	11 074	9492	8252	7138	6109	5294	4545	3057	1851
				(31,000)	(10'8")	(32,914)	(24,413)	(20,926)	(18,193)	(15,737)	(13,467)	(11,672)	(10,019)	(6740)	(4080)
					2.15	4.2	6.4	7.5	8.6	9.9	11.3	13.0	14.9	19.3	29.3
Challenger 65C	2ZJ	93-95	285/225	14 330	3.24	12 587	9574	8186	7156	6147	5230	4497	3855	2701	1637
				(31,530)	(10'8")	(27,750)	(21,106)	(18,046)	(15,775)	(13,551)	(11,530)	(9914)	(8498)	(5955)	(3610)
					2.29	4.2	6.4	7.5	8.6	9.9	11.3	13.0	14.9	19.3	29.1
Challenger 65D	2ZJ	95-97	300	14 909	3.24	12 689	10 706	9161	7934	6837	5843	5005	4256	3119	2030
				(32,875)	(10'8")	(27,975)	(23,603)	(20,197)	(17,492)	(15,072)	(12,881)	(11,034)	(9382)	(6875)	(4475)
					2.29	4.2	6.4	7.5	8.6	9.9	11.3	13.0	14.9	19.3	29.1
Challenger 65E	97-02	310/277		15 186	3.4	15 098	10 808	9265	8096	6964	6017	5247	4469	3396	2279
				(33,480)	(11'2")	(33,284)	(23,827)	(20,425)	(17,849)	(15,352)	(13,265)	(11,567)	(9853)	(7488)	(5025)
					4.3	6.4	7.6	8.7	10.0	11.3	12.9	14.8	19.3	29.0	
Challenger 70C	2YL	93-95	1st Gear 215/154 2nd & up 285/225	16 201	3.24	12 621	9574	8186	7156	6147	5230	4497	3855	2701	1637
				(35,685)	(10'8")	(27,825)	(21,106)	(18,046)	(15,775)	(13,551)	(11,530)	(9914)	(8498)	(5955)	(3610)
					2.29	4.2	6.4	7.5	8.6	9.9	11.3	13.0	14.9	19.3	21.1
Challenger 75	4CJ	91-92	325/256	14 060	3.24	15 391	12 371	10 753	9382	8073	6923	6017	5162	3588	2181
				(31,000)	(10'8")	(33,931)	(27,273)	(23,706)	(20,684)	(17,797)	(15,263)	(13,264)	(11,379)	(7910)	(4830)
					2.15	4.2	6.4	7.5	8.6	9.9	11.3	13.0	14.9	19.3	29.3
Challenger 75C	4KK	92-97	325/268	15 158	3.24	12 689	10 761	9329	8106	6932	5944	5095	4380	3075	1878
				(33,419)	(10'8")	(27,975)	(23,724)	(20,567)	(17,871)	(15,282)	(13,105)	(11,232)	(9657)	(6780)	(4140)
					2.29	4.2	6.4	7.5	8.6	9.9	11.3	13.0	14.9	19.3	29.1
Challenger 75D	5AR	96-97	330	14 878	3.24	12 884	12 562	10 919	9526	8197	7030	6109	5241	3643	2225
				(32,800)	(10'8")	(28,406)	(27,693)	(24,071)	(21,003)	(18,071)	(15,498)	(13,468)	(11,554)	(8031)	(4904)
					2.29	4.2	6.4	7.5	8.6	9.9	11.3	13.0	14.9	19.3	29.1
Challenger 75E	97-02	340/301		15 186	3.4	15 174	11 696	9402	8155	7015	6412	5543	4798	3502	2447
				(33,480)	(11'2")	(33,452)	(25,785)	(20,728)	(17,979)	(15,466)	(14,135)	(12,221)	(10,578)	(7722)	(5395)
					2.29	4.5	6.4	7.9	9.0	10.3	11.3	12.9	14.8	20.1	29.0
Challenger 85C	9TK	92-97	1-2 Gears 325/216 3-10 Gears 355/272	15 186	3.24	12 689	11 596	9544	8302	7089	6406	5490	4720	3146	2024
				(33,480)	(10'8")	(27,975)	(25,565)	(21,042)	(18,304)	(15,629)	(14,122)	(12,104)	(10,406)	(6935)	(4461)
					2.29	4.5	6.4	7.9	9.0	10.5	11.3	13.0	14.9	20.3	29.1
Challenger 85D	4GR	96-97	Gears 1-2 330 3-5 360 6-10 370	15 286	3.24	15 529	10 684	9599	8247	7175	6590	5705	4887	3825	2461
				(33,700)	(10'8")	(34,234)	(23,553)	(21,162)	(18,181)	(15,819)	(14,528)	(12,578)	(10,774)	(8432)	(5425)
					2.29	4.0	6.25	7.75	8.9	10.2	11.2	12.8	14.7	20.3	29.1
Challenger 85E	97-02	375/339		15 413	3.4	15 454	11 576	10 566	9177	7997	7268	6323	5417	3954	2763
				(33,980)	(11'2")	(34,070)	(25,520)	(23,294)	(20,232)	(17,629)	(16,022)	(13,940)	(11,942)	(8718)	(6090)
					2.29	4.5	6.4	7.9	9.0	10.3	11.3	12.9	14.8	20.1	29.0
					(7'6")	(2.8)	(4.0)	(4.9)	(5.6)	(6.4)	(7.0)	(8.0)	(9.2)	(12.5)	(18.0)

*Drawbar pull figures for SA and SR models are max. at lug.

NOTE: Drawbar pull figures for the Challenger 65 is at max. power as found in University of Nebraska Tractor Test no. 1268.

This test was performed on concrete. Therefore, usable drawbar pull may be less depending upon soil conditions.

Agricultural Tractors (cont'd)

Model	Product Ident. No. Prefix	Years Built	Horse-power FW/ Drawbar	Approx. Machine Weight kg (lb)	Height m (ft) Gauge m (ft)	Drawbar Pull kg (lb)* and Forward Speed km/h (mph)									
						1st	2nd	3rd	4th	5th	6th	7th	8th	9th	10th
						Challenger 95E	97-02	410/375	15 413 (33,980)	3.4 (11'2") 2.29 (7'6")	15 968 (35,202) 4.5 (2.8)	11 506 (25,366) 6.4 (4.0)	10 505 (23,159) 7.9 (4.9)	10 085 (22,234) 9.0 (5.6)	8729 (19,244) 10.3 (6.4)
D3B SA	2PC	85-87	101 6650 (14,670)	2.71 (8'11")	7634 (16,830) 4.1 (2.5)	6226 (13,725) 5.0 (3.1)	5306 (11,700) 5.7 (3.6)	4531 (9990) 6.5 (4.0)	3888 (8573) 7.6 (4.7)						
D3C SA	7JF	87-92	101 7202 (15,846)	2.71 (8'11") 1.52 (5'0")	5552 (12,250) 4.1 (2.5)	4521 (9960) 5.0 (3.1)	3827 (8450) 5.7 (3.6)	3235 (7130) 6.5 (4.0)	2755 (6070) 7.6 (4.7)						
D4D SA	20J	66-68	—/68 6750 (14,900)	2.44 (8'0") 1.52 (5'0")	4590 (10,120) 4.0 (2.5)	3928 (8660) 4.7 (2.9)	3098 (6830) 5.6 (3.5)	2631 (5800) 6.4 (4.0)	2232 (4920) 7.4 (4.6)						
D4D SA	84J	66	—/68 6470 (14,270)	2.67 (8'9") 1.52 (5'0")	4880 (10,750) 4.0 (2.5)	4170 (9200) 4.7 (2.9)	3310 (7300) 5.6 (3.5)	2840 (6260) 6.4 (4.0)	2420 (5330) 7.4 (4.6)						
D4E SA	7PB 2CB	84-89 84-91	97 7600 (16,760)	2.71 (8'11")	5901 (13,102) 3.4 (2.1)	5148 (11,349) 4.6 (2.8)	5831 (12,859) 5.5 (3.5)	5002 (11,027) 6.4 (4.0)	4433 (9773) 8.3 (5.1)						
D4E SA	29X	77-84	—/74 7585 (16,722)	2.72 (8'11") 1.52 (5'0")	5802 (12,791) 4.1 (2.5)	4986 (10,993) 4.7 (2.9)	4007 (8835) 5.8 (3.6)	3814 (8408) 6.6 (4.1)	2896 (6384) 7.5 (4.7)						
D4E SR		84-99	125/— 9400 (20,730)	1.93 (6'4") 1.52 (5'0")	5450 (12,010) 1.52 (5'0")	3744 (8250)	5068 (11,170)	4408 (9715)	3832 (8450)						
D5 SA	21J	67-67	—/90 9300 (20,400)	2.64 (8'8") 1.88 (6'2")	6620 (14,580) 1.88 (6'2")	5160 (11,360)	3990 (8740)	3080 (6790)	2290 (5030)						
D5 SA	98J	67-77	—/90 9660 (21,300)	2.95 (9'8") 1.88 (6'2")	6120 (13,500) 3.7 (2.3)	5180 (11,410) 4.6 (2.9)	4110 (9950) 5.8 (3.6)	3640 (7620) 7.1 (4.4)	2950 (6500) 8.8 (5.5)	2250 (4970)					
D5B SA	26X	77-84	—/90	2.77 (9'1") 1.88 (6'2")	6409 (14,130) 4.0 (2.5)	5384 (11,870) 4.7 (2.9)	4323 (9530) 5.6 (3.5)	3688 (8130) 6.6 (4.1)	3180 (7010) 7.4 (4.6)	2486 (5480) 9.0 (5.6)					
D5B SA	22X	77-82	105/— 11 283 (24,875)	2.77 (9'1") 1.52 (5'0")	8060 (17,770) 2.7 (1.7)	5030 (11,100) 4.2 (2.6)	3410 (7520) 5.8 (3.6)	2290 (5060) 8.0 (5.0)	1480 (3260) 11.1 (6.9)						
D5B SA	24X	77-84	105/— 11 619 (25,615)	2.77 (9'1") 1.52 (5'0")	3.5 (2.2)	6.1 (3.8)	10.1 (6.3)								

*Drawbar pull figures for SA and SR models are max. at lug.

NOTE: Drawbar pull figures for the Challenger 65 is at max. power as found in University of Nebraska Tractor Test no. 1268. This test was performed on concrete. Therefore, usable drawbar pull may be less depending upon soil conditions.

Agricultural Tractors (cont'd)

Model	Product Ident. No. Prefix	Years Built	Horse-power FW/ Drawbar	Approx. Machine Weight kg (lb)	Height m (ft) Gauge m (ft)	Drawbar Pull kg (lb)* and Forward Speed km/h (mph)											
						1st	2nd	3rd	4th	5th	6th	7th	8th	9th	10th		
D6C SA	17R	70-76	140	13 064 (28,800)	2.67 (8'9")	850 (18,750)	6970 (15,370)	5880 (12,780)	4810 (10,610)	4080 (9000)	3190 (7030)						
D6D SR	7XF	89-91	140	15 200 (33,500)	2.87 (9'5")	4.0 (2.5)	4.8 (3.0)	5.6 (3.5)	6.4 (4.0)	7.4 (4.6)	8.8 (5.5)						
D6D SA 123-161 kW (165-215 HP)	38C	83-91	165	14 500 (32,000)	2.87 (9'5")	14 358 (31,645)	12 429 (27,394)	11 721 (25,833)	7067 (15,576)	6096 (13,436)	4931 (10,868)						
D6D SA 123-179 kW (165-240 HP)	19B	83-91	165	14 500 (32,000)	2.87 (9'5")	2.0 (1.2)	2.9 (1.8)	4.1 (2.5)	6.5 (4.0)	7.4 (4.6)	8.9 (5.5)						
D6E SR	8FJ	91-96	155/216 121/170	14 960 (32,987)	2.03 (6'8")	10 098 (22,243)	8510 (18,744)	9210 (20,287)	7789 (17,156)	6732 (14,828)	5456 (12,017)						
Ag 6 Generation One	05X	77-86	165/240	14 787 (32,600)	3.43 (11'3")	4.5 (2.8)	5.3 (3.3)	6.1 (3.8)	7.1 (4.4)	8.2 (5.1)							
Ag 6 Generation Two	05X	77-86	200/240	14 787 (32,600)	3.48 (11'5")	12 407 (27,353)	10 482 (23,110)	10 667 (23,514)	9091 (19,931)	7830 (17,263)							
D7G SA std. trans.	35N	80-86	250	18 462 (40,700)	3.2 (10'6")	19 101 (42,110)	13 622 (30,030)	11 358 (25,040)	10 015 (22,080)	8627 (19,020)	7584 (16,720)						
D7G SA std. trans. 168-186 kW (225-250 HP)		77-86	250	18 462 (40,700)	3.2 (10'6")	3.5 (2.2)	4.8 (3.0)	5.6 (3.5)	6.4 (4.0)	7.2 (4.5)	8.2 (5.1)						
D8L SA		84-87	400	36 650 (80,820)	3.87 (12'8")	40 252 (88,740)	39 466 (64,960)	22 013 (48,530)	15 953 (35,170)	11 880 (26,190)	8446 (18,620)						
					2.2 (7'3")	2.9 (1.8)	3.9 (2.4)	5.0 (3.1)	6.8 (4.2)	8.9 (5.5)	11.9 (7.4)						

*Drawbar pull figures for SA and SR models are max. at lug.

NOTE: Drawbar pull figures for the Challenger 65 is at max. power as found in University of Nebraska Tractor Test no. 1268.

This test was performed on concrete. Therefore, usable drawbar pull may be less depending upon soil conditions.



MOTOR GRADERS

Model	Product Ident. No. Prefix	Years Built	Horsepower, Rated	Approx. Ship Wt. kg (lb)	Wheel-base m (ft)	Length m (ft)	Width m (ft)	Mold-board Length m (ft)	Turning Radius m (ft)	Controls	Maximum Speed	
											Forward km/h (mph)	Rev. km/h (mph)
212TD	79C	54-57	50	6030 (13,290)	5.03 (16'6")	6.68 (21'11")	2.07 (6'10")	3.05 (10'0")	11.10 (36'5")	Mech.	18.1 (11.2)	4.2 (2.6)
112	3U	47-59	70	8770 (19,330)	5.72 (18'9")	7.59 (24'11")	2.39 (7'10")	3.66 (12'0")	10.87 (35'8")	Mech.	25.7 (16.0)	6.4 (4.0)
112	81C	55-59	75	9435 (20,805)	5.72 (18'9")	7.59 (24'11")	2.39 (7'10")	3.66 (12'0")	10.74 (35'3")	Mech.	25.7 (16.0)	6.4 (4.0)
112E	68E(U.S.)	59-64	85	9500 (20,900)	5.72 (18'9")	7.62 (25'0")	2.36 (7'9")	3.66 (12'0")	10.74 (35'3")	Mech.	29.3 (18.2)	9.3 (5.8)
112F	82F(U.S.)	60-64	100	9800 (21,600)	5.72 (18'9")	7.82 (25'8")	2.36 (7'9")	3.66 (12'0")	10.70 (35'3")	Mech.	29.9 (18.6)	9.7 (6.0)
	74H(U.S.)	67-68										
	89J(U.S.)	68-74										
	80J(AUSTL)	69-84										
120	89G(U.S.)	64-67	115	10 480 (23,100)	5.71 (18'9")	7.62 (25'0")	2.36 (7'9")	3.66 (12'0")	10.74 (35'3")	Mech.	32.2 (20.0)	10.3 (6.4)
120	14K(U.S.)	67-69	125	10 600 (23,500)	5.71 (18'9")	7.80 (25'8")	2.36 (7'9")	3.66 (12'0")	10.74 (35'3")	Mech.	32.2 (20.0)	41.5 (25.8)
120	10R(U.S.)	69-74	125	10 700 (23,700)	5.85 (19'2")	7.95 (26'1")	2.36 (7'9")	3.66 (12'0")	10.90 (35'9")	Mech.	32.2 (20.0)	6.6 (4.1)
120	13U(U.S.)	71-74	125	11 000 (24,300)	5.85 (19'2")	7.95 (26'1")	2.36 (7'9")	3.66 (12'0")	10.90 (35'9")	Mech.	32.2 (20.0)	6.6 (4.1)
120B	64U(BRAZ)	72-89	125	12 000 (26,460)	5.85 (19'2")	7.92 (26'0")	2.36 (7'9")	3.66 (12'0")	10.90 (35'9")	Mech.	35.4 (22.0)	23.8 (14.8)
120G	87V(U.S.)	73-95	125	12 859 (28,350)	5.69 (18'8")	7.92 (26'0")	2.45 (8'0")	3.66 (12'0")	6.7 (22'0")	Hyd.	40.9 (25.4)	40.9 (25.4)
	4HD(BRAZ)	86-95										
	11W(AUSTL)	75-95										
	82V(CAN)	74-80										
120H	4MK(U.S.)	95-02	125/140	12 520 (27,600)	5.86 (19'3")	8.26 (27'1")	2.44 (7'11")	3.66 (12'0")	7.2 (23'8")	Hyd.	42.6 (26.5)	33.7 (20.9)
	6NM(U.S.)											
	9YR(BRAZ)											
	2AN(AUSTL)											
	3GR(S. AFRICA)											
	124 (AUSTL)	03-05										
	ALZ(U.S.)	02-04										
	CAF(BRAZ)	03-07										
120H	ALZ(U.S.)	02-03	125/140	12 650 (27,880)	5.92 (19'5")	8.31 (27'3")	2.44 (8'0")	3.66 (12'0")	7.3 (23'7")	Hyd.	42.6 (26.5)	33.7 (20.9)
	CAF(BRAZ)	02-07										
	124(AUSTL)	03-05										
120H	6TM(U.S.)	96-99	125/140	12 466 (27,483)	5.87 (19'3")	8.15 (26'9")	2.44 (8'0")	3.66 (12'0")	7.2 (23'8")	Hyd.	42.6 (26.5)	33.7 (20.9)
STD	5FM(BRAZ)	96-09										
	9FN(INDO)	96-04										

Motor Graders (cont'd)

Model	Product Ident. No. Prefix	Years Built	Horsepower, Rated	Approx. Ship Wt. kg (lb)	Wheel-base m (ft)	Length m (ft)	Width m (ft)	Mold-board Length m (ft)	Turning Radius m (ft)	Controls	Maximum Speed	
											km/h (mph)	km/h (mph)
130G	74V(U.S.)	73-95	135	13 050	5.92	8.30	2.45	3.66	7.3	Hyd.	39.4	39.4
	12W(AUSTL)	75-89		(28,770)	(19'5")	(27'3")	(8'0")	(12'0")	(24'0")		(24.5)	(24.5)
135H	3YK(U.S.)	95-02	135/155	12 950	5.86	8.26	2.44	3.66	7.2	Hyd.	41.9	33.1
	AMX(U.S.)	02-04		(28,550)	(19'3")	(27'1")	(7'11")	(12'0")	(23'8")		(26.0)	(20.6)
135H	CBC(BRAZ)	03-07	135/155	13 080	5.92	8.31	2.44	3.66	7.3	Hyd.	41.9	33.1
	AMX(U.S.)	02-04		(28,840)	(19'5")	(27'3")	(8'0")	(12'0")	(23'7")		(26.1)	(20.6)
12	6M(U.S.)	39-42	66	9440	5.72	7.62	2.39	3.66	10.87	Mech.	24.5	6.1
				(20,820)	(18'9")	(25'0")	(7'10")	(12'0")	(35'8")		(15.2)	(3.8)
12	9K(U.S.)	38-45	70	9590	5.72	7.62	2.39	3.66	10.87	Mech.	24.5	6.1
				(21,140)	(18'9")	(25'0")	(7'10")	(12'0")	(35'8")		(15.2)	(3.8)
12	7T(U.S.)	45-47	75	9750	5.72	7.62	2.39	3.66	10.87	Mech.	24.5	6.1
				(21,500)	(18'9")	(25'0")	(7'10")	(12'0")	(35'8")		(15.2)	(3.8)
12	8T(U.S.)	47-55	100	10 100	5.72	7.62	2.39	3.66	10.87	Mech.	31.1	6.6
	94C(AUSTL)	55-58		(22,375)	(18'9")	(25'0")	(7'10")	(12'0")	(35'8")		(19.3)	(4.1)
12	70D-71D(U.S.)	57-59	115	10 200	5.72	7.62	2.37	3.66	10.87	Mech.	31.1	10.1
	80C(U.S.)	55-67		(22,410)	(18'9")	(25'0")	(7'10")	(12'0")	(35'8")		(19.3)	(6.3)
	38E(AUSTL)	58-60										
12E	99E(U.S.)	59-65	115	11 100	5.72	8.03	2.36	3.66	10.90	Mech.	32.0	22.2
	21F(AUSTL)	60-68		(24,400)	(18'9")	(26'4")	(7'9")	(12'0")	(35'9")		(19.9)	(13.8)
	17K(AUSTL)	68-75										
12F	73G(U.S.)	65-67	115	12 973	6.0	8.20	2.36	3.66	11.40	Hyd.	32.0	22.2
				(28,600)	(19'8")	(26'10")	(7'9")	(12'0")	(37'5")	Mech.	(19.9)	(13.8)
12F	89H(U.S.)	69-73	125	12 973	6.00	8.20	2.36	3.65	11.40	Hyd.	34.3	41.5
	13K(U.S.)	67-73		(28,600)	(19'8")	(26'10")	(7'9")	(12'0")	(37'5")		Mech.	(21.3)
12G	61M(U.S.)	73-95	135	13 554	5.92	8.30	2.45	3.66	7.30	Hyd.	39.4	39.4
	3PL(BRAZ)	93-95		(29,860)	(19'5")	(27'3")	(8'0")	(12'0")	(24'0")		(24.5)	(24.5)
	3WC(AUSTL)	85-95										
12H	4XM(U.S.)	95-02	140	14 247	6.10	8.57	2.44	3.66	7.40	Hyd.	39.7	31.3
	2LR(U.S.)			(31,410)	(20'0")	(28'1")	(7'11")	(12'0")	(24'3")		(24.7)	(19.5)
	8MN(BRAZ)											
	2GS(BRAZ)											
	2WR(AUSTL)											
12H	AMZ(U.S.)	02-07	145/185	14 200	6.09	8.57	2.44	3.66	7.40	Hyd.	44.0	34.7
	CBK(BRAZ)	02-07		(31,320)	(20'0")	(28'1")	(8'0")	(12'0")	(24'3")		(27.4)	(21.6)
	125(AUSTL)	03-05										
12H	AMZ(U.S.)	02-07	140	14 185	6.09	8.45	2.44	3.66	7.4	Hyd.	41.7	32.9
	CBK(BRAZ)	02-07		(31,273)	(20'0")	(27'9")	(8'0")	(12'0")	(24'3")		(25.9)	(20.5)
	125(AUSTL)	03-05										
12H	5ZM(U.S.)	97-98	140	14 185	6.09	8.45	2.44	3.66	7.4	Hyd.	41.7	32.9
STD	4ER(BRAZ)	96-09		(31,273)	(20'0")	(27'9")	(8'0")	(12'0")	(24'3")		(25.9)	(20.5)
	XZJ(CHINA)	06-10										

Motor Graders (cont'd)

Model	Product Ident. No. Prefix	Years Built	Horsepower, Rated	Approx. Ship Wt. kg (lb)	Wheel-base m (ft)	Length m (ft)	Width m (ft)	Mold-board Length m (ft)	Turning Radius m (ft)	Controls	Maximum Speed	
											Forward km/h (mph)	Rev. km/h (mph)
140	14U(U.S.)	71-74	150	13 109	5.84	7.95	2.44	3.66	10.97	Mech.	38.8	47.0
	11R(U.S.)	70-74		(28,900)	(19'2")	(26'1")	(8'0")	(12'0")	(36'0")		(24.1)	(29.2)
	55F(AUSTL)	71-75										
140B	24R(CAN)	71-74	150	13 620	6.14	8.07	2.39	3.96	11.60	Mech.	37.6	25.6
	61S(BRAZ)	81-87		(30,003)	(20'2")	(26'6")	(7'10")	(13'0")	(38'0")		(23.4)	(15.9)
140G	72V(U.S.)	73-95	150	14 102	5.92	8.33	2.45	3.66	7.30	Hyd.	41.0	41.0
	5MD(BRAZ)	87-95		(31,090)	(19'5")	(27'4")	(8'0")	(12'0")	(24'0")		(25.5)	(25.5)
	13W(AUSTL)	75-95										
140G AWD	81V(CAN)	74-80	150	14 914	5.92	8.33	2.45	3.66	7.30	Hyd.	41.0	41.0
	72V(U.S.)	73-95		(32,880)	(19'5")	(27'4")	(8'0")	(12'0")	(24'0")		(25.5)	(25.5)
140H	2ZK(U.S.)	95-02	165/185	14 724	6.10	8.60	2.46	3.66	7.40	Hyd.	41.1	32.4
	8KM(U.S.)			(32,460)	(20'0")	(28'3")	(8'1")	(12'0")	(24'3")		(25.5)	(20.2)
	9TN(BRAZ)											
	3AS(BRAZ)											
	9ZN(AUSTL)											
140H	APM(U.S.)	02-07	165/205	14 677	6.17	8.71	2.46	3.66	7.5	Hyd.	44.0	34.7
	CCA(BRAZ)	02-07		(32,357)	(20'3")	(28'7")	(8'1")	(12'0")	(24'7")		(27.4)	(21.6)
	126(AUSTL)	03-05										
140H STD	8JM(U.S.)	96-99	165/185	14 661	6.09	8.60	2.46	3.66	7.4	Hyd.	41.1	32.4
	5HM(BRAZ)	96-09		(32,321)	(20'0")	(28'3")	(8'1")	(12'0")	(24'3")		(25.5)	(20.2)
143H	XZH(CHINA)	05-10	165/185	15 023	6.10	8.60	2.46	3.66	7.40	Hyd.	41.1	32.4
	1AL(U.S.)	95-02		(33,120)	(20'0")	(28'3")	(8'1")	(12'0")	(24'3")		(25.5)	(20.2)
143H	APN(U.S.)	02-07	165/205	15 270	6.17	8.71	2.55	3.66	7.5	Hyd.	44.0	34.7
				(33,670)	(20'3")	(28'7")	(8'5")	(12'0")	(24'7")		(27.4)	(21.6)
14B	78E(U.S.)	59-59	150	13 300	5.84	8.03	2.44	3.66	10.97	Mech.	34.8	11.3
	64C(U.S.)	59-69		(29,280)	(19'2")	(26'4")	(8'0")	(12'0")	(36'0")		(21.6)	(7.0)
14C	35F(U.S.)	59-61	150	12 973	5.84	8.03	2.44	3.66	10.97	Mech.	34.8	11.3
				(28,600)	(19'2")	(26'4")	(8'0")	(12'0")	(36'0")		(21.6)	(7.0)
14D	96F(U.S.)	61-65	150	13 700	6.15	8.33	2.44	3.96	11.58	Mech.	34.1	23.5
				(30,300)	(20'2")	(27'4")	(8'0")	(13'0")	(38'0")		(21.2)	(14.6)
14E	99G(U.S.)	65-68	150	13 699	6.15	8.33	2.44	3.96	11.58	Hyd.	36.4	24.9
				(30,200)	(20'2")	(27'4")	(8'0")	(13'0")	(38'0")		(22.6)	(15.5)
14E	12K(U.S.)	67-73	150	14 300	6.10	8.30	2.44	3.96	11.60	Mech.	39.1	47.3
	72G(U.S.)	69-73		(31,600)	(20'2")	(27'4")	(8'0")	(13'0")	(38'0")		(24.3)	(29.4)
14G	96U(U.S.)	73-95	200	20 688	6.45	9.21	2.83	4.27	7.90	Hyd.	43.0	50.1
				(45,610)	(21'2")	(30'3")	(9'3")	(14'0")	(25'11")		(26.8)	(31.1)
14H	7WJ(U.S.)	95-02	215	18 784	6.45	9.21	2.70	4.27	7.90	Hyd.	42.7	47.3
	ASE(U.S.)	02-07		(41,410)	(21'2")	(30'2")	(8'10")	(14'0")	(25'11")		(26.5)	(29.4)
14H	ASE(U.S.)	02-07	220/240	18 809	6.56	9.34	2.82	4.27	8.0	Hyd.	46.1	51.1
				(41,465)	(21'6")	(30'8")	(9'3")	(14'0")	(26'4")		(28.7)	(31.8)

Motor Graders (cont'd)

Model	Product Ident. No. Prefix	Years Built	Horsepower, Rated	Approx. Ship Wt. kg (lb)	Wheel-base m (ft)	Length m (ft)	Width m (ft)	Mold-board Length m (ft)	Turning Radius m (ft)	Controls	Maximum Speed	
											km/h (mph)	km/h (mph)
160H	9EJ(U.S.)	95-02	180/200	15 586	6.10 (20'0")	8.60 (28'3")	2.46 (8'1")	4.27 (14'0")	7.40 (24'3")	Hyd.	40.7	32.1
	6WM(U.S.)			(34,360)							(25.3)	(20.0)
	3GM(BRAZ)											
	2HS(BRAZ)											
160H	ASD(U.S.)	02-07	180/220	15 676	6.17 (20'3")	8.71 (28'7")	2.48 (8'2")	4.27 (14'0")	7.5 (24'7")	Hyd.	43.6	34.4
	CCP(BRAZ)	02-07									(34,560)	(27.1)
160H	9JM(U.S.)	96-99	180/200	15 524	6.09 (20'0")	8.49 (27'10")	2.46 (8'1")	4.27 (14'0")	7.4 (24'3")	Hyd.	40.7	32.1
STD	2FM(BRAZ)	96-98									(34,225)	(25.3)
	XZK(CHINA)	06-10										
163H	5AK(U.S.)	95-02	180/200	16 538	6.10 (20'0")	8.60 (28'3")	2.46 (8'1")	4.27 (14'0")	7.40 (24'3")	Hyd.	40.7	32.1
	ARL(U.S.)	02-07		(36,460)							(25.3)	(20.0)
163H	ARL(U.S.)	02-07	180/220	16 280	6.17 (20'3")	8.71 (28'7")	2.55 (8'5")	4.27 (14'0")	7.5 (24'7")	Hyd.	43.6	34.4
				(35,890)	(27.1)	(21.4)						
16	49G(U.S.)	63-73	225	22 499	6.86 (22'6")	9.50 (31'2")	3.00 (9'10")	4.27 (14'0")	13.56 (44'6")	Hyd.	49.7	49.7
				(49,600)	(30.9)	(30.9)				Mech.	(30.9)	(30.9)
16G	93U(U.S.)	73-95	275	27 284	6.96 (22'10")	9.99 (32'8")	3.08 (10'1")	4.88 (16'0")	8.20 (27'0")	Hyd.	43.6	43.6
				(60,150)	(27.1)	(27.1)					(27.1)	(27.1)
16H	6ZJ(U.S.)	95-02	275	24 748	6.96 (22'10")	9.99 (32'9")	2.99 (9'10")	4.88 (16'0")	8.20 (27'0")	Hyd.	44.5	42.3
	ATS(U.S.)	02-07		(54,560)							(27.7)	(26.3)
16H	ATS(U.S.)	02-07	265/285	24 740	6.96 (22'10")	9.99 (32'9")	3.08 (10'1")	4.88 (16'0")	8.2 (26'11")	Hyd.	48.1	45.7
				(54,550)	(29.9)	(28.4)					(29.9)	(28.4)
16M	B9H	07-10	291/326	27 531	6.99 (22'11")	9.96 (32'8")	3.10 (10'2")	4.88 (16'0")	8.9 (29'3")	Electro-Hyd	51.7	40.8
	R9H	10-15		(60,695)							(32.1)	(25.3)
24H	7KK(U.S.)	96-07	500	61 955	10.23 (33'7")	14.16 (46'6")	4.23 (13'10")	7.3 (24'0")	12.0 (39'11")	Hyd.	37.7	36.1
				(136,611)	(23.4)	(22.4)					(23.4)	(22.4)



SKID STEER LOADERS

Model	Product Ident. No. Prefix	Years Built	Approx. Machine		Length to Coupler mm (in)	Width over Tires mm (in)**	Height to Top of Cab mm (in)	Engine Model	Top Travel Speed km/h (mph)	Rated Operating Capacity	
			Weight kg (lb)	Net Power kW (hp)						Rated Operating Capacity at 50% kg (lb)	Rated Operating Capacity at 50% with counter-weight kg (lb)
216	4NZ	99-03	2490 (5490)	36 (48)	2519 (99)	1525 (60)	1950 (77)	3024C	11.5 (7.0)	635 (1400)	680 (1500)
216B	RLL	04-07	2589 (5709)	37 (49)	2519 (99)	1525 (60)	1950 (77)	3024C	12.7 (7.9)	635 (1400)	680 (1500)
216B2	RLL	07-10	3212 (7082)	35 (47)	2519 (99)	1525 (60)	1950 (77)	C2.2	12.7 (7.9)	635 (1400)	680 (1500)
226	5FZ	99-03	2560 (5645)	41 (54)	2519 (99)	1525 (60)	1950 (77)	3034	11.5 (7.0)	680 (1500)	726 (1600)
226B	MJH	04-07	2646 (5834)	42 (57)	2519 (99)	1525 (60)	1950 (77)	3024CT	12.7 (7.9)	680 (1500)	726 (1600)
226B2	MJH	07-10	3283 (7238)	42 (56)	2519 (99)	1525 (60)	1950 (77)	C2.2T	12.7 (7.9)	680 (1500)	726 (1600)
228	6BZ	99-03	2650 (5843)	41 (54)	2519 (99)	1525 (60)	1950 (77)	3034	11.5 (7.0)	680 (1500)	726 (1600)
232	CAB	02-04	3005 (6627)	36 (48)	2776 (110)	1525 (60)	1953 (77)	3024C	11.1 (7.0)	793 (1750)	815 (1795)
232B	SCH	04-07	3021 (6661)	37 (49)	2760 (109)	1525 (60)	1953 (77)	3024C	11.1 (6.9)	793 (1750)	815 (1795)
232B2	SCH	07-10	3588 (7910)	42 (56)	2760 (109)	1525 (60)	1950 (77)	C2.2T	11.1 (6.9)	862 (1900)	883 (1947)
236	4YZ	99-03	3134 (6810)	44 (59)	2800 (110)	1676 (66)	2092 (82)	3034	12.1 (7.5)	793 (1750)	839 (1850)
236B	HEN	04-07	3178 (7007)	52 (70)	2800 (110)	1676 (66)	2092 (82)	3044C DIT	12.2/18.6* (7.6/11.6*)	793 (1750)	815 (1850)
236B2	HEN	07-10	3878 (8550)	53 (71)	2800 (110)	1676 (66)	2092 (82)	C3.4 DIT	12.1 (7.5)	884 (1950)	929 (2050)
236B3	A9H	10-13	3178 (7007)	53 (71)	2800 (110)	1676 (66)	2092 (82)	Cat® C3.4 DIT	18.1 (11.2)	884 (1950)	929 (2050)
242	CMB	02-04	3060 (6748)	41 (54)	2776 (110)	1676 (66)	1986 (78)	3034	11.3 (7.0)	907 (2000)	930 (2045)
242B	BXM	04-07	3085 (6805)	42 (57)	2760 (109)	1676 (66)	1986 (78)	3024CT	12.0 (7.4)	907 (2000)	930 (2045)
242B2	BXM	07-10	3629 (8000)	42 (56)	2760 (109)	1676 (66)	1986 (78)	C2.2T	12.1 (7.5)	952 (2100)	Standard on 242B2
242B3	SRS	10-13	3179 (7008)	53 (71)	2760 (108.7)	1676 (66)	2019 (79)	Cat C3.4 DIT	18.4 (11.4)	975 (2150)	1000 (2200)

*With two-speed option.

**Models 216-236B with 254 mm (10") wide tires, 242-268B with 305 mm (12") wide tires.

Skid Steer Loaders (cont'd)

Model	Product Ident. No. Prefix	Years Built	Approx. Machine		Length to Coupler mm (in)	Width over Tires mm (in)**	Height to Top of Cab mm (in)	Engine Model	Top Travel Speed km/h (mph)	Rated Operating Capacity	
			Weight kg (lb)	Net Power kW (hp)						Operating Capacity at 50% kg (lb)	with counter-weight kg (lb)
246	5SZ	99-03	3214 (7087)	55 (74)	2800 (110)	1676 (66)	2092 (82)	3034T	12.1 (7.5)	907 (2000)	952 (2100)
246B	PAT	04-07	3239 (7142)	58 (78)	2800 (110)	1676 (66)	2092 (82)	3044CT	12.5/19.1* (7.7/11.8*)	907 (2000)	952 (2100)
246C	JAY	08-13	3393 (7480)	54 (73)	3692 (145.3)	1676 (66)	2104 (82.8)	Cat C3.4 DIT	19.3 (12.0)	975 (2150)	1066 (2350)
248	6LZ	99-03	3328 (7338)	55 (74)	2800 (110)	1676 (66)	2092 (82)	3034T	12.1 (7.5)	907 (2000)	952 (2100)
248B	SCL	04-07	3320 (7321)	57 (76)	2800 (110)	1676 (66)	2092 (82)	3044C DIT	12.5/19.1* (7.7/11.8*)	907 (2000)	952 (2100)
252	FDG	01-03	3454 (7615)	44 (59)	2776 (110)	1829 (72)	1968 (78)	3034	12.1 (7.5)	1020 (2250)	1043 (2300)
252B	SCP	04-07	3552 (7832)	52 (70)	2902 (114)	1829 (72)	2063 (81)	3044C DIT	11.2/17.8* (6.9/11.0*)	1134 (2500)	1134 (2500)
252B2	SCP	07-10	4172 (9198)	53 (71)	2901 (114)	1829 (72)	2063 (83)	C3.4 DIT	12.1 (7.5)	1134 (2500)	1157 (2551)
252B3	TNK	10-13	3565 (7861)	53 (71)	2901 (114.2)	1829 (72)	2063 (82.6)	Cat C3.4 DIT	17.8 (11.1)	1202 (2650)	1225 (2700)
262	CED	01-03	3472 (7655)	55 (74)	2902 (114)	1829 (72)	2098 (83)	3034T	12.1 (7.5)	1134 (2500)	1156 (2550)
262B	PDT	04-07	3565 (7861)	58 (78)	2902 (114)	1829 (72)	2063 (81)	3044C DIT	11.6/17.8* (7.2/11.0*)	1225 (2700)	1247 (2750)
262C	MST	08-13	3614 (7968)	61 (82)	2979 (117.3)	1676 (66)	2104 (82.8)	Cat C3.4 DIT	19.3 (12.0)	1225 (2700)	1336 (2945)
262C2	TMW	12-13	3614 (7968)	54 (73)	2979 (117.3)	1676 (66)	2104 (82.8)	Cat C3.4 DIT	19.3 (12.0)	1225 (2700)	1336 (2945)
268B	LBA	04-07	3626 (7995)	57 (76)	2902 (114)	1829 (72)	2063 (81)	3044C DIT	11.6/17.8* (7.2/11.0*)	1225 (2700)	1247 (2750)
272C	RED	08-13	3793 (8362)	67 (90)	3120 (122.8)	1676 (66)	2104 (82.8)	Cat C3.4 DIT	16.1 (10.0)	1474 (3250)	1579 (3480)
272D	GSL	12-13	3812 (8404)	71 (95)	3139 (123.6)	1930 (76)	2104 (82.8)	Cat C3.8 DIT	15.1 (9.4)	1451 (3200)	1565 (3450)
272D	SHY	12-13	4220 (9403)	79 (106)	3119 (122.8)	1930 (76)	2104 (84.3)	Cat C3.8 DIT	15.1 (9.4)	1633 (3600)	—
272D	B5W	13-15	3743 (8252)	71 (95)	3156 (124.3)	1829 (72)	2111 (83.1)	Cat C3.8 DIT	15.1 (9.4)	1451 (3200)	1565 (3450)
272D	ETL	13-15	4220 (9403)	79 (106)	3136 (123.5)	1930 (76)	2147 (84.5)	Cat C3.8 DIT	16.6 (10.3)	1678 (3700)	—

*With two-speed option.

**Models 216-236B with 254 mm (10") wide tires, 242-268B with 305 mm (12") wide tires.



MULTITERRAIN LOADERS

Model	Product Ident. No. Prefix	Years Built	Approx. Machine Weight kg (lb)	Net Power kW (hp)	Length to Coupler mm (in)	Width over Tracks mm (in)*	Height to Top of Cab mm (in)	Engine Model	Top Travel Speed km/h (mph)	Rated Operating Capacity at 50% kg (lb)
247	CML	02-04	3023 (6665)	41 (54)	2518 (99)	1676 (66)	1990 (78)	3034	12.1 (7.5)	877 (1933)
247B	MTL	04-07	3024 (6668)	42 (57)	2518 (99)	1676 (66)	1990 (78)	3024CT	12.2 (7.6)	885 (1950)
247B2	MTL	07-10	3497 (7710)	42 (56)	2518 (8'3")	1676 (5'6")	1990 (6'6")	C2.2T	0-11.3 (0-7.0)	929 (2050)
247B3	MTL	10-15	3174 (6997)	42 (56)	2518 (99.0)	1676 (66.0)	1990 (78.0)	Cat C2.2T	11.3 (7.0)	975 (2150)
257	CMM	02-04	3460 (7628)	44 (59)	2701 (106)	1676 (66)	2022 (80)	3034T	12.1 (7.5)	1046 (2306)
257B	SLK	04-07	3428 (7559)	42 (57)	2701 (106)	1676 (66)	2022 (80)	3024CT	11.4 (7.1)	1047 (2310)
257B2	SLK	7-10	3906 (8611)	42 (56)	2701 (8'10")	1676 (5'6")	2022 (6'7")	C2.2T	0-11.3 (0-7.0)	1134 (2500)
257B3	B7H	10-13	3656 (8060)	53 (71)	2718 (107)	1676 (66)	2035 (80)	Cat C3.4 DIT	16.1 (10.0)	1213 (2675)
267	CMP	01-04	4134 (9088)	44 (59)	2923 (115)	1898 (75)	2074 (82)	3034	9.7 (6.0)	1315 (2900)
267B	CYC	04-07	4250 (9371)	52 (70)	2923 (115)	1898 (75)	2074 (82)	3044C DIT	11.2 (7.0)	1315 (2900)
277	CNC	01-04	4148 (9126)	55 (74)	2923 (115)	1898 (75)	2074 (82)	3034T	9.7 (6.0)	1338 (2950)
277B	MDH	04-07	4269 (9411)	58 (78)	2923 (115)	1898 (75)	2074 (82)	3044C DIT	11.2 (7.0)	1338 (2950)
277C	JWF	08-13	4307 (9495)	61 (82)	2974 (117.2)	1981 (78)	2115 (83.2)	Cat C3.4 DIT	14.9 (9.3)	1451 (3200)
277C2	MET	12-13	4307 (9495)	54 (73)	2974 (117.2)	1981 (78)	2115 (83.2)	Cat C3.4 DIT	14.9 (9.3)	1451 (3200)
287	CNY	03-04	4471 (9870)	55 (74)	2900 (114)	1962 (77)	2122 (84)	3034T	11.0 (7.0)	1587 (3500)
287B	ZSA	04-07	4660 (10,275)	58 (78)	2900 (114)	1962 (77)	2122 (84)	3044C DIT	11.2 (7.0)	1632 (3600)
287C	MAS	08-13	4517 (9958)	61 (82)	2974 (117.2)	1981 (78)	2115 (83.2)	Cat C3.4 DIT	14.9 (9.3)	1724 (3800)
287C2	SSB	12-13	4517 (9958)	54 (73)	2974 (117.2)	1981 (78)	2115 (83.2)	Cat C3.4 DIT	14.9 (9.3)	1724 (3800)
297C	GCP	07-12	4870 (10,736)	67 (90)	2974 (108)	1981 (78)	2115 (83)	C3.4 DIT	9.0 (5.6) 14.9 (9.2)	1060 (2337)
297D	BE7	14-15	4590 (10,120)	71 (95)	3155 (124.2)	1935 (76.2)	2125 (83.6)	Cat C3.8 DIT	15.1 (9.4)	2063 (4550)
297D XHP	HP7	14-15	4905 (10,815)	79 (106)	3155 (124.2)	1935 (76.2)	2125 (83.6)	Cat C3.8 DIT	15.1 (9.4)	2268 (5000)

*With 457 mm (18") wide track.



COMPACT TRACK LOADERS

Model	Product Ident. No. Prefix	Years Built	Approx. Machine Weight kg (lb)	Net Power kW (hp)	Length to Coupler mm (in)	Width over Tracks mm (in)	Height to Top of Cab mm (in)	Engine Model	Top Travel Speed km/h (mph)	Rated Operating Capacity at 50% kg (lb)
259B3*	YYZ	10-13	4052 (8934)	53 (71)	2722 (107)	1676 (66)	1986 (78)	Cat C3.4 DIT	13.6 (8.5)	1338 (2950)
279C	MBT	10-13	4487 (9892)	61 (82)	2960 (116.5)	1981 (78)	2117 (83.3)	Cat C3.4 DIT	13.6 (8.5)	1451 (3200)
279C2	KWB	12-13	4475 (9865)	54 (73)	2960 (116.5)	1981 (78)	2117 (83.3)	Cat C3.4 DIT	13.6 (8.5)	1383 (3050)
289C	JMP	10-13	4702 (10,365)	61 (82)	2960 (116.5)	1981 (78)	2117 (83.3)	Cat C3.4 DIT	13.6 (8.5)	1746 (3850)
289C2	RTD	12-13	4687 (10,332)	54 (73)	2960 (116.5)	1981 (78)	2117 (83.3)	Cat C3.4 DIT	13.6 (8.5)	1656 (3650)
299C	JSP	10-13	4867 (10,730)	67 (90)	3101.0 (122.1)	1981 (78)	2117 (83.3)	Cat C3.4 DIT	13.6 (8.5)	1882 (4150)
299D	HCL	12-13	4943 (10,898)	71 (95)	3138 (123.5)	1931 (76)	2104 (82.8)	Cat C3.8 DIT	13.6 (8.5)	1928 (4250)
299D XHP	NLC	12-13	5283 (11,647)	79 (106)	3138 (123.5)	1931 (76)	2104 (82.8)	Cat C3.8 DIT	13.6 (8.5)	1882 (4150)
299D	GTC	13-15	4862 (10,718)	71 (95)	3136 (123.5)	1931 (76)	2127 (83.7)	Cat C3.8 DIT	13.5 (8.4)	1928 (4250)
299D XHP	JST	13-15	5267 (11,612)	79 (106)	3136 (123.5)	1931 (76)	2127 (83.7)	Cat C3.8 DIT	13.5 (8.4)	2109 (4650)

*Configured with 320 mm (12.6") tracks.



HYDRAULIC EXCAVATORS (Track)

Model	Product Ident. No. Prefix COSA (US)	Years Built	Flywheel Horsepower	Approx. Operating Weight kg (lb)	Track Gauge m (ft)	Height* m (ft)	Length* m (ft)	Width m (ft)	Max. Reach** m (ft)	Lift Capacity*** kg (lb)
205 LC	(3HC) (4DC)	84-89	Deutz-67 Perkins®-71	13 135 (28,957)	1.895 (6'2.5")	3.00 (9'10")	7.30 (23'11")	2.40 (7'10")	8.17 (26'10")	3290 (7300)
205B	5ZF	90-92	80	12 900 (28,443)	1.895 (6'2.5")	2.976 (9'9")	7.67 (25'2")	2.495 (8'2")	8.9 (29'2")	3740 (8250)
211 LC	(4EC) (5CC)	84-89	Deutz-84 Perkins-94	15 540 (34,260)	2.08 (6'9.9")	3.02 (9'11")	8.01 (26'3")	2.49 (8'2")	9.88 (32'5")	4240 (9340)
213 LC	3ZC	83-87	102	17 300 (38,140)	2.08 (6'10")	3.08 (10'1")	8.34 (27'4")	2.49 (8'2")	10.30 (33'9.5")	5127 (11,305)
215	(96L) (57Z) (14Z)	76-80 79-84	85 90	17 450 (38,480)	1.92 (6'4")	3.10 (10'1")	8.94 (29'4")	2.47 (8'0")	9.25 (30'4")	5090 (11,200)
215 SA	(57Y) (14Z)	82-84	90	19 440 (42,860)	2.18 (7'2")	3.22 (10'6")	8.94 (29'4")	2.73 (8'11")	9.23 (30'3")	5130 (11,300)
215B LC	(9YB)	84-87	105	18 510 (40,806)	1.92 (6'4")	3.10 (10'2")	8.94 (29'4")	2.44 (8'0")	9.25 (30'4")	5760 (12,700)
215C LC	(4HG)	87-89	115	19 570 (43,150)	1.92 (6'4")	3.1 (10'2")	8.94 (29'4")	2.42 (7'11")	9.29 (30'6")	7070 (15,200)
215D LC	(9TF)	89-92	125	19 900 (43,900)	1.92 (6'4")	3.2 (10'6")	9.0 (24'6")	2.44 (8'0")	9.23 (30'3")	6830 (14,700)
219	(5CF)	87-89	130	21 120 (46,550)	2.18 (7'2")	3.12 (10'3")	8.94 (29'4")	2.73 (8'11")	10.39 (34'1")	7080 (15,300)
219D	(5XG)	89-92	140	21 600 (47,500)	2.18 (7'2")	3.12 (10'3")	9.41 (30'10")	2.73 (8'11")	9.75 (32'0")	7670 (16,500)
219 LC	(5CF)	87-89	130	22 020 (48,550)	2.18 (7'2")	3.12 (10'3")	8.94 (29'4")	2.73 (8'11")	10.39 (34'1")	7080 (15,300)
219D LC	(5XG)	89-92	140	22 400 (49,300)	2.18 (7'2")	3.12 (10'3")	9.41 (30'10")	2.73 (8'11")	9.75 (32'0")	7670 (16,500)
225 LC	(51U)	72-86	135	23 900 (52,700)	2.64 (8'8")	3.17 (10'5")	9.83 (32'3")	2.99 (9'10")	9.58 (31'5")	7300 (15,600)
225 SA	(51U)	77-86	135	27 125 (59,800)	2.64 (8'8")	3.17 (10'5")	9.83 (32'3")	3.35 (11'0")	9.55 (31'4")	7340 (15,700)
225B	(2ZD) (3YD)	86-89 87-89	145	24 960 (55,030)	2.44 (8'0")	3.17 (10'5")	9.83 (32'3")	2.99 (9'10")	10.16 (33'4")	11 040 (26,100)
225D	(6RG)	89-91	150	25 400 (55,900)	2.44 (8'0")	3.23 (10'7")	9.94 (32'7")	2.99 (9'10")	10.13 (33'3")	— —
225B LC	(2ZD) (3YD)	86-89 87-89	145	26 140 (58,230)	2.44 (8'0")	3.17 (10'5")	9.83 (32'3")	2.99 (9'10")	10.16 (33'4")	11 040 (26,100)
225D LC	(2SJ)	89-91	165	26 700 (58,900)	2.44 (8'0")	3.23 (10'7")	9.94 (32'7")	2.99 (9'10")	10.13 (33'3")	12 450 (26,900)

*When shipped with medium stick and bucket curled under.

**Maximum reach at ground level, one-piece boom, longest stick.

***Lift capacity at 4.6 m (15'0") over front, one-piece boom, longest stick.

Hydraulic Excavators (Track) (cont'd)

Model	Product Ident. No. Prefix COSA (US)	Years Built	Flywheel Horsepower	Approx. Operating Weight kg (lb)	Track Gauge m (ft)	Height* m (ft)	Length* m (ft)	Width m (ft)	Max. Reach** m (ft)	Lift Capacity*** kg (lb)
229	(1GF)	86-89	145	29 140	2.64	3.38	9.83	3.45	10.11	—
	(1AF)	86-89		(64,830)	(8'8")	(11'1")	(32'3")	(11'4")	(33'2")	—
229 LC	(1GF)	86-89	180	33 540	2.64	3.38	11.02	3.45	11.35	7940
Custom 180				(73,940)	(8'8")	(11'1")	(36'2")	(11'4")	(37'3")	(17,100)
229D	(2LJ)	89-91	157	31 700	2.64	3.52	10.9	3.25	10.76	8300
				(69,900)	(8'8")	(11'7")	(35'9")	(10'8")	(35'4")	(18,300)
231D		90-92	200	34 300	2.64	3.45	10.83	3.45	11.20	15 300
				(75,600)	(8'8")	(11'4")	(35'6")	(11'4")	(36'9")	(33,000)
231D LC		90-92	200	35 500	2.64	3.45	10.83	3.45	11.20	15 300
				(78,100)	(8'8")	(11'4")	(35'6")	(11'4")	(36'9")	(33,000)
235	(32K)	73-86	195	39 320	2.69	3.40	11.27	3.45	11.23	7050
	(64R)			(86,700)	(8'10")	(11'2")	(37'0")	(11'4")	(36'10")	(17,300)
235B	(7WC)	86-88	215	40 960	2.69	3.40	11.27	3.45	11.23	9934
	(9PC)			(89,700)	(8'10")	(11'2")	(37'0")	(11'4")	(36'10")	(21,900)
235C	(4DG) (5AF)	88-92	250	42 140	2.69	3.50	11.50	3.45	12.00	14 720
	(2PG) (3WG)			(92,800)	(8'10")	(11'4")	(37'7")	(11'4")	(39'5")	(35,000)
235D	(8KJ)	92-93	250	46 270	2.69	3.50	11.50	3.45	12.00	14 840
	(8TJ)			(103,780)	(8'10")	(11'5")	(37'7")	(11'4")	(39'5")	(35,200)
235D LC	(8KJ)	92-93	250	49 270	3.30	3.60	11.60	3.79	11.97	15 070
	(8TJ)			(108,620)	(10'10")	(11'9")	(38'1")	(12'5")	(39'3")	(35,700)
245	(82X)	74-88	325	65 745	3.24	4.62	13.18	3.71	14.02	14 930
	(84X)			(144,941)	(10'7")	(15'2")	(43'3")	(12'2")	(46'0")	(32,920)
245B	6MF	88-92	360	65 200	3.24	4.78	13.13	3.61	14.02	—
	1SJ			(143,500)	(10'7")	(15'8")	(43'1")	(11'10")	(46'0")	—
245D	(4LK)	92-93	385	68 420	3.24	5.46	12.82	3.61	13.84	14 640†
	(7ZJ)			(150,520)	(10'7")	(17'11")	(42'0")	(11'10")	(45'9")	(31,600)
E70	3BG	87-89	52	6500	1.65	2.59	6.02	2.25	6.67	1300
	3CG	87-89		(14,300)	(5'5")	(8'6")	(19'9")	(7'5")	(21'10")	(2750)
E70B	7YF(JPN)	89-94	54	6760	1.75	2.56	6.09	2.32	6.72	1315
	5TG(OSJ)	89-94		(14,900)	(5'9")	(8'5")	(20'0")	(7'7")	(22'1")	(2900)
	6AK(OSJ)	92-94								
E110	3FG	87-89	74	10 700	1.9	2.73	7.345	2.5	7.93	2700
	3GG	87-89		(23,600)	(6'3")	(8'11")	(24'0")	(8'2")	(26'0")	(5750)
E110B	9HF(OSJ)	90-92	79	11 600	1.99	2.70	7.25	2.495	8.10	3350
	8MF(JPN)	90-92		(25,600)	(6'6")	(8'10")	(23'9")	(8'2")	(26'7")	(7200)
	5GK(OSJ)	90-92								

*When shipped with medium stick and bucket curled under.

**Maximum reach at ground level, one-piece boom, longest stick.

***Lift capacity at 4.6 m (15'0") over front, one-piece boom, longest stick.

†Lift capacity at 7.5 m (25'0") over front, one-piece boom, longest stick.

Hydraulic Excavators (Track) (cont'd)

Model	Product Ident. No. Prefix COSA (US)	Years Built	Flywheel Horsepower	Approx. Operating Weight kg (lb)	Track Gauge m (ft)	Height* m (ft)	Length* m (ft)	Width m (ft)	Max. Reach** m (ft)	Lift Capacity*** kg (lb)
E120	1LF(OSJ)	87-89	84	12 200	1.99	2.775	7.66	2.490	8.58	3850
	1MF(JPN)	87-89		(26,800)	(6'6")	(9'1")	(25'1")	(8'2")	(28'2")	(8300)
E120B	7NF(OSJ)	90-92	84	12 680	1.99	2.70	7.62	2.495	8.74	4310
	6JF(JPN)	90-92		(28,200)	(6'6")	(8'10")	(25'10")	(8'2")	(28'8")	(9250)
	4XK(OSJ)	90-92								
E140	1PF(JPN)	87-94	89	13 970	1.99	2.89	8.29	2.55	5.49	4380
	1NF(OSJ)			(30,800)	(6'6")	(9'6")	(27'6")	(8'4")	(18'0")	(9650)
E200B	6KF(OSJ)	87-91	118	18 800	2.20	2.97	9.48	2.83	10.63	8100
	4SG(JPN)	87-91		(41,400)	(7'3")	(9'9")	(3'11")	(9'4")	(34'10")	(17,350)
EL200B	7DF(OSJ)	87-91	118	20 100	2.38	2.97	9.48	3.18	10.63	8150
	5EG(JPN)	87-91		(44,300)	(7'10")	(9'9")	(31'1")	(10'5")	(34'10")	(17,600)
E240	1FG(OSJ)	87-89	148	23 000	2.39	3.02	9.73	3.19	10.6	9800
	2HF(JPN)	87-89		(50,700)	(7'10")	(9'11")	(31'11")	(10'6")	(34'9")	(21,600)
E240B	8SF(OSJ)	89-92	148	23 000	2.39	3.02	9.73	3.19	10.6	9800
	9PF(JPN)			(50,700)	(7'10")	(9'11")	(31'11")	(10'6")	(34'9")	(21,600)
E240C	2RL(OSJ)	92-93	148	23 000	2.39	3.02	9.73	3.19	10.6	9800
	8MK(JPN)			(50,700)	(7'10")	(9'11")	(31'11")	(10'6")	(34'9")	(21,600)
EL240	4JF(OSJ)	87-89	148	23 600	2.58	3.02	9.73	3.38	10.6	11 300
	4MF(JPN)	87-89		(52,000)	(8'6")	(9'11")	(31'11")	(11'1")	(34'9")	(24,300)
EL240B	5WG(OSJ)	89-92	148	23 600	2.58	3.02	9.73	3.38	10.6	10 320
	6MG(JPN)			(52,000)	(8'6")	(9'11")	(31'11")	(11'1")	(34'9")	(22,750)
EL240C	9PK(OSJ)	92-93	148	23 600	2.58	3.02	9.73	3.38	10.6	10 320
	9NK(JPN)			(52,000)	(8'6")	(9'11")	(31'11")	(11'1")	(34'9")	(22,750)
E300	2CF(OSJ)	87-89	187	30 500	2.6	3.22	10.94	3.4	11.84	12 550
	1KG(JPN)	87-89		(67,300)	(8'6")	(10'7")	(35'11")	(11'2")	(38'9")	(27,650)
E300B	1WJ(OSJ)	90-91	206	30 200	2.6	3.22	10.94	3.4	11.84	12 450
	2HJ(JPN)	90-91		(66,580)	(8'6")	(10'7")	(35'11")	(11'2")	(38'9")	(26,850)
EL300	4NF(OSJ)	87-89	187	31 600	2.6	3.22	10.94	3.4	11.84	12 550
	4SF(JPN)	87-89		(69,700)	(8'6")	(10'7")	(35'11")	(11'2")	(38'9")	(27,650)
EL300B	3FJ(OSJ)	90-91	206	31 200	2.6	3.22	10.94	3.4	11.84	12 450
	1GK(JPN)	90-91		(68,780)	(8'6")	(10'7")	(35'11")	(11'2")	(38'9")	(26,850)
E450	3HG(OSJ)	87-93	276	46 000	2.89	3.49	11.96	3.15	13.08	10 900
	3JG(JPN)	87-93		(101,430)	(9'6")	(11'5")	(39'3")	(10'4")	(42'11")	(23,500)
E650	3KG(OSJ)	87-92	375	62 600	3.25	4.84	14.0	3.49	13.33	15 850
	3LG(JPN)	87-92		(138,000)	(10'8")	(15'11")	(45'11")	(11'5")	(43'9")	(34,000)

*When shipped with medium stick and bucket curled under.

**Maximum reach at ground level, one-piece boom, longest stick.

***Lift capacity at 4.6 m (15'0") over front, one-piece boom, longest stick.

Hydraulic Excavators (Track) (cont'd)

Model	Product Ident. No. Prefix COSA (US)	Years Built	Flywheel Horsepower	Approx. Operating Weight kg (lb)	Track Gauge m (ft)	Height* m (ft)	Length* m (ft)	Width m (ft)	Max. Reach** m (ft)	Lift Capacity*** kg (lb)
301.5	3YW	98-05	17.4	1650 (3640)	0.75 (2'6")	2.19 (7'2")	3.69 (12'1")	0.98 (3'3")	3.8 (12'6")	380† (830)
301.6	BDH	00-05	17.4	1690 (3726)	0.75 (2'6")	2.19 (7'2")	3.69 (12'1")	0.98 (3'3")	3.8 (12'6")	370† (810)
301.8	BFA	00-05	17.4	1725 (3803)	0.75 (2'6")	2.19 (9'8")	3.69 (12'1")	0.98 (3'3")	3.8 (12'6")	370† (810)
302.5	4AZ	99-05	22.9	2730 (6020)	1.15 (3'9")	2.3 (7'7")	4.52 (14'10")	1.45 (4'9")	4.83 (15'10")	870† (1910)
303 CR	DMA	01-05	26.1	3210 (7077)	1.25 (4'1")	2.48 (8'2")	4.68 (15'4")	1.55 (5'1")	5.39 (17'8")	1200† (2646)
303C CR	BXT	06-10	29.5	7573 (3435)	1.25 (4'1")	2.5 (8'2")	4.73 (15'6")	15.5 (5'1")	5.1 (16'9")	1200 (2646)
303.5	AFW	99-02	25	7430 (7546)	1.25 (4'1")	2.44 (8'0")	5.07 (16'6")	1.55 (5'1")	5.54 (18'2")	1030† (2270)
303.5C CR	DCH	01-02		3790 (8356)	1.48 (4'10")	2.5 (8'2")	4.82 (15'10")	17.8 (5'10")	5.35 (17'7")	1630 (3594)
303.5D CR	DMY	06-10	38.9	3770 (8300)	1.48 (4'10")	2.5 (8'2")	4.73 (15'6")	1.78 (5'10")	5.32 (17'5")	1340† (2950)
303.5E CR	RHP	10-12	30	3800 (8380)	1.48 (4'10")	2.5 (8'2")	4.73 (15'6")	1.78 (5'10")	5.32 (17'5")	1340† (2950)
303.5E CR	RKY	11-	31.6	3800 (8380)	1.48 (4'10")	2.5 (8'2")	4.73 (15'6")	1.78 (5'10")	5.32 (17'5")	1340† (2950)
304 CR	NAD	02-05	35.5	4300 (9480)	1.58 (5'2")	2.6 (8'6")	5.18 (17'0")	1.98 (6'6")	5.95 (19'6")	2250† (5000)
304C CR	FPK	06-10	41.6	4800 (10,582)	1.58 (5'2")	2.55 (8'4")	5.17 (17'0")	19.8 (6'6")	5.46 (17'11")	2250 (5000)
304D CR	TYK	10-12	39	4080 (8995)	1.60 (5'3")	2.5 (8'2")	4.82 (15'10")	1.95 (6'5")	5.47 (18'0")	1570† (3460)
304E CR	TTN	11-	40	4000 (8820)	1.6 (5'3")	2.5 (8'2")	4.82 (15'10")	1.95 (6'5")	5.47 (18'0")	1570† (3460)
304.5	ANK	99-02	38	4475 (9866)	1.5 (4'11")	2.5 (8'4")	5.7 (18'8")	1.9 (6'6")	6.05 (19'10")	1600† (3630)
304.5	WAK	01-02		4800 (10,582)	1.58 (5'2")	2.6 (8'6")	5.37 (17'7")	1.98 (6'6")	6.14 (20'2")	2550† (5622)
305 CR	DSA	01-03	42	4800 (10,582)	1.58 (5'2")	2.6 (8'6")	5.37 (17'7")	1.98 (6'6")	6.14 (20'2")	2550† (5622)
305 CR	DGT	03-05	42	4800 (10,582)	1.58 (5'2")	2.6 (8'6")	5.37 (17'7")	1.98 (6'6")	6.14 (20'2")	2550† (5622)
305C CR	HWJ	06-10	46.9	5200 (11,464)	1.58 (5'2")	2.55 (8'4")	5.33 (17'6")	19.8 (6'6")	5.65 (18'6")	2550 (5622)
305D CR	XER	10-11	42	5260 (11,600)	1.58 (5'2")	2.55 (8'4")	5.18 (17'0")	1.98 (6'6")	5.81 (19'1")	2250† (4960)
305E CR	XFA	11-14	40	5210 (11,490)	1.58 (5'2")	2.55 (8'4")	5.18 (17'0")	1.98 (6'6")	5.81 (19'1")	2250† (4960)
305.5D CR	FLZ	10-12	47	5560 (12,260)	1.58 (5'2")	2.55 (8'4")	5.33 (17'6")	1.98 (6'6")	6.02 (19'9")	2480† (5470)
305.5E CR	FKY	11-14	44.2	5480 (12,080)	1.58 (5'2")	2.55 (8'4")	5.33 (17'6")	1.98 (6'6")	6.02 (19'9")	2490† (5490)

*When shipped with medium stick and bucket curled under.

**Maximum reach at ground level, one-piece boom, longest stick.

***Lift capacity at 4.6 m (15'0") over front, one-piece boom, longest stick.

†Lift capacity at 3 m (10'0") over front, blade down, one-piece boom, longest stick.

Hydraulic Excavators (Track) (cont'd)

Model	Product Ident. No. Prefix COSA (US)	Years Built	Flywheel Horsepower	Approx. Operating Weight kg (lb)	Track Gauge m (ft)	Height* m (ft)	Length* m (ft)	Width m (ft)	Max. Reach** m (ft)	Lift Capacity*** kg (lb)
307	2WM	94-98	54	7600 (16,760)	1.75 (5'9")	2.61 (8'7")	6.3 (20'8")	2.4 (7'11")	6.38 (20'11")	2450 (5400)
	2PM(OSJ)	94-98	54	6740 (14,860)	1.75 (5'9")	2.63 (8'8")	6.08 (19'11")	2.28 (7'6")	6.72 (22'1")	1350 (3000)
	9ZL(JPN)	94-97	54	6650 (14,660)	1.75 (5'9")	2.63 (8'8")	6.08 (19'11")	2.28 (7'6")	6.72 (22'1")	1350 (3000)
307B	5CW(OSJ)	98-00	54	6960 (15,340)	1.75 (5'9")	2.63 (8'8")	6.08 (19'11")	2.28 (7'6")	6.72 (22'1")	1350 (3000)
	4RW(JPN)	97-00	54	6500 (14,330)	1.75 (5'9")	2.64 (8'8")	6.08 (19'11")	2.28 (7'6")	6.72 (22'1")	1350 (3000)
307B SB	AFB	99-00	40/54	7500 (16,530)	1.75 (5'9")	2.9 (9'6")	6.75 (22'2")	2.28 (7'6")	7.01 (23'0")	1410 (3100)
	6KZ(OSJ) 7DZ(JPN) (BCM)	98-01	40/54	8040 (17,730)	1.75 (5'9")	2.64 (8'8")	6.73 (22'1")	2.28 (7'6")	7.42 (24'4")	1500 (3300)
307C	BAJ	00-09	54	7210 (15,900)	1.75 (5'9")	2.78 (9'1")	6.07 (19'11")	2.29 (7'6")	6.85 (22'6")	947 (2100)
	BAJ	00-08	54	6450 (14,220)	1.75 (5'9")	2.63 (8'8")	6.07 (19'11")	2.29 (7'6")	6.34 (20'10")	1052 (2300)
307C SB	(BNE)	00-07	54	8390 (18,500)	1.75 (5'9")	2.63 (8'8")	6.79 (22'3")	2.29 (7'6")	7.55 (24'9")	822 (1800)
307D	DSG	07-12	55.6	7075 (15,600)	1.84 (6'0")	2.63 (8'8")	6.07 (19'11")	2.29 (7'6")	6.67 (21'11")	3650† (8050)
	H1Y	12-	55.6	7160 (15,785)	1.75 (5'9")	2.63 (8'8")	6.07 (19'11")	2.29 (7'6")	6.16 (20'3")	4200† (9260)
308B CR	3YS(JPN)	99-02	54	7650 (16,870)	1.85 (6'1")	2.61 (8'7")	5.77 (18'11")	2.3 (7'7")	6.9 (22'8")	1600 (3500)
308C CR	(KCX)	02-07	54	8040 (17,730)	1.87 (6'2")	2.61 (8'7")	5.83 (19'2")	2.47 (8'1")	6.9 (22'8")	947 (2100)
	CPE	01-08	54	7390 (16,290)	1.87 (6'2")	2.61 (8'7")	5.83 (19'2")	2.32 (7'7")	6.39 (21'0")	1135 (2500)
308D CR	GBT	07-12	55.6	7850 (17,310)	1.87 (6'2")	2.63 (8'7")	5.81 (19'1")	2.32 (7'7")	6.71 (22'0")	3650† (8050)
308D SB	FYC	07-12	55.6	8400 (18,520)	1.87 (6'2")	2.59 (8'6")	6.45 (21'2")	2.32 (7'7")	7.43 (24'5")	3200† (7055)
	GBJ	11-13	65	8330 (18,365)	1.87 (6'2")	2.55 (8'4")	6.38 (20'11")	2.32 (7'7")	7.35 (24'1")	3610† (7960)
311	9LJ(OSJ)	93-96	79	11 100 (24,470)	1.99 (6'6")	2.76 (9'1")	7.25 (23'9")	2.49 (8'2")	8.1 (26'7")	3100 (6800)
	5PK(JPN)	93-96	79	11 050 (24,360)	1.99 (6'6")	2.76 (9'1")	7.25 (23'9")	2.49 (8'2")	8.10 (26'7")	3100 (6800)

*When shipped with medium stick and bucket curled under.

**Maximum reach at ground level, one-piece boom, longest stick.

***Lift capacity at 4.6 m (15'0") over front, one-piece boom, longest stick.

†Lift capacity at 3 m (10'0") over front, blade down, one-piece boom, longest stick.

Hydraulic Excavators (Track) (cont'd)

Model	Product Ident. No. Prefix COSA (US)	Years Built	Flywheel Horsepower	Approx. Operating Weight kg (lb)	Track Gauge m (ft)	Height* m (ft)	Length* m (ft)	Width m (ft)	Max. Reach** m (ft)	Lift Capacity*** kg (lb)
311B	2LS(blade) (OSJ)	96-01	79	11 890 (26,210)	1.99 (6'6")	2.76 (9'1")	7.25 (23'9")	2.495 (8'2")	8.1 (26'7")	3080 (6800)
	2MS(blade) (JPN)	96-01	79	11 900 (26,230)	1.99 (6'6")	2.76 (9'1")	7.25 (23'9")	2.5 (8'2")	8.1 (26'7")	3100 (6800)
	8GR(OSJ)	96-01	79	11 130 (24,540)	1.99 (6'6")	2.76 (9'1")	7.25 (23'9")	2.495 (8'2")	8.1 (26'7")	3120 (6900)
	8HR(JPN)	96-01	79	11 200 (24,690)	1.99 (6'6")	2.76 (9'1")	7.25 (23'9")	2.49 (8'2")	8.1 (26'7")	3100 (6800)
	311C U (CKE)	01-07	79	11 980 (26,410)	1.99 (6'6")	2.77 (9'1")	6.92 (22'8")	2.49 (8'2")	8.225 (27'0")	1295 (2900)
	CLK	01-07	79	11 500 (25,350)	1.99 (6'6")	2.765 (9'1")	6.88 (22'7")	2.49 (8'2")	7.7 (25'3")	1453 (3200)
311D RR	AKW(JPN)	08-14	80	11 930 (26,310)	1.99 (6'6")	2.86 (9'5")	6.84 (22'5")	2.49 (8'2")	8.1 (26'7")	3350 (7150)
311D LRR	CLA(OSJ)	08-13	80	12 480	1.99	2.86	6.91	2.49	8.1	3900
	DDW	08-09		(27,520)	(6'6")	(9'5")	(22'8")	(8'2")	(26'7")	(8350)
	(PNJ)	10-13								
	LKA	09-12								
	KRM(OSJ)	10-14								
312	6BL	93-97	84	12 600	1.99	2.76	7.6	2.49	8.63	4200
	6GK(OSJ)	93-96		(27,780)	(6'6")	(9'1")	(24'11")	(8'2")	(28'4")	(9300)
	7DK(JPN)	93-96	84	12 000 (26,460)	1.99 (6'6")	2.76 (9'1")	7.6 (24'11")	2.49 (8'2")	8.63 (28'4")	4050 (8900)
312B	6SW	98-01	84	13 000 (28,660)	1.99 (6'6")	2.91 (9'7")	7.59 (24'11")	2.49 (8'2")	8.3 (27'3")	4590 (10,110)
	9GR(OSJ)	98-01	84	12 440 (27,430)	1.99 (6'6")	2.76 (9'1")	7.595 (24'11")	2.495 (8'2")	8.625 (28'4")	4170 (9200)
	9HR(JPN)	98-00	84	12 150 (26,790)	1.99 (6'6")	2.76 (9'1")	7.595 (24'11")	2.49 (8'2")	8.625 (28'4")	4050 (8900)
	9NW(blade)	98-01	66/88	13 785 (30,390)	1.99 (6'6")	2.91 (9'7")	7.59 (24'11")	2.49 (8'2")	8.3 (27'3")	4940 (10,900)
	2NS(blade) (OSJ)	98-01	66/88	13 200 (29,100)	1.99 (6'6")	2.76 (9'1")	7.595 (24'11")	2.495 (8'2")	8.625 (28'4")	4230 (9300)
	3ES(blade) (JPN)	98-00	84	12 900 (28,440)	1.99 (6'6")	2.76 (9'1")	7.595 (24'11")	2.49 (8'2")	8.625 (28'4")	4200 (9300)
	312B L 9FS	97-01	84	13 270 (29,260)	1.99 (6'6")	2.91 (9'7")	7.59 (24'11")	2.59 (8'6")	8.3 (27'3")	5000 (11,000)
	8JR(OSJ)	98-01	66/88	12 940 (28,530)	1.99 (6'6")	2.76 (9'1")	7.595 (24'11")	2.59 (8'6")	8.625 (28'4")	4930 (10,900)
	2KW(blade)	97-01	84	14 055 (30,990)	1.99 (6'6")	2.91 (9'7")	7.59 (24'11")	2.59 (8'6")	8.3 (27'3")	5050 (11,100)
	3FS(blade) (OSJ)	98-01	66/88	13 720 (30,250)	1.99 (6'6")	2.76 (9'1")	7.595 (24'11")	2.59 (8'6")	8.625 (28'4")	4920 (10,800)

*When shipped with medium stick and bucket curled under.

**Maximum reach at ground level, one-piece boom, longest stick.

***Lift capacity at 4.6 m (15'0") over front, one-piece boom, longest stick.

Hydraulic Excavators (Track) (cont'd)

Model	Product Ident. No. Prefix COSA (US)	Years Built	Flywheel Horsepower	Approx. Operating Weight kg (lb)	Track Gauge m (ft)	Height* m (ft)	Length* m (ft)	Width m (ft)	Max. Reach** m (ft)	Lift Capacity*** kg (lb)
312C	BNN(FDS)	01-07	90	12 860 (28,350)	1.99 (6'6")	2.76 (9'1")	7.57 (24'10")	2.59 (8'6")	8.74 (28'8")	1402 (3100)
	CAE	00-	90	12 200 (26,900)	1.99 (6'6")	2.75 (9'0")	7.57 (24'10")	2.49 (8'2")	8.3 (27'3")	1448 (3200)
	BNN	01-	71/96	13 000 (28,665)	1.99 (6'6")	2.91 (9'6")	7.59 (24'11")	2.49 (8'2")	8.3 (27'3")	4350 (10,120)
312C L	CBT(CBA)	01-07	90	13 140 (28,970)	1.99 (6'6")	2.76 (9'1")	7.57 (24'10")	2.59 (8'6")	8.74 (28'8")	1439 (3200)
	CBT	01-	71/96	13 270 (29,260)	1.99 (6'6")	2.91 (9'6")	7.59 (24'11")	2.59 (8'6")	8.3 (27'3")	5040 (11,025)
312D	HCW(OSJ)	08-12	90	13 120	1.99	2.83	7.61	2.49	8.62	4300
	HJX	08-11		(28,930)	(6'6")	(9'3")	(25'0")	(8'2")	(28'3")	(9250)
	PHH	09-11								
	DLP(CHN)	08-12								
	LRK(CHN)	10-12								
312D L	RHL(OSJ)	10-14								
	JBC(OSJ)	08-12	90	13 650	1.99	2.83	7.61	2.49	8.62	5000
	(XGK)	10-11		(30,100)	(6'6")	(9'3")	(25'0")	(8'2")	(28'3")	(10,750)
	KCD	08-11								
	TGY	08-08								
	SKA	11-11								
313B CR	RKF	09-11								
	KES(OSJ)	10-14								
313B CR	BAS(OSJ)	00-02	89	13 225 (29,160)	1.99 (6'6")	2.82 (9'3")	7.17 (23'6")	2.49 (8'2")	8.55 (28'1")	3900 (8600)
	AEX(JPN)	99-02	89	12 750 (28,110)	1.99 (6'6")	2.82 (9'3")	7.17 (23'6")	2.49 (8'2")	8.24 (27'0")	3900 (8600)
313C CR	HGF(JPN)	01-08		12 600 (27,780)	1.99 (6'6")	2.82 (9'3")	7.28 (23'11")	2.49 (8'2")	8.63 (28'4")	3600 (7700)
	WSA(JPN)	02-08		13 900 (30,650)	1.99 (6'6")	2.82 (9'3")	7.48 (24'7")	2.49 (8'2")	7.23 (23'9")	3400 (7250)
313D	KXD(CHN)	12-12	90	13 430	1.99	2.83	7.61	2.49	8.22	4150
	WPK(CHN)	12-13		(29,610)	(6'6")	(9'3")	(25'0")	(8'2")	(27'0")	(8900)
313D SR	LBR(JPN)	08-12	77	14 400 (31,750)	1.99 (6'6")	2.8 (9'3")	7.49 (24'7")	2.49 (8'2")	7.23 (23'9")	3450 (7400)
	(KJA)	02-02	90	14 610 (32,210)	1.99 (6'6")	2.81 (9'3")	7.28 (23'11")	2.59 (8'6")	8.765 (28'9")	1351 (3000)
314C CR	KHB	01-	90	13 500 (29,760)	1.99 (6'6")	2.81 (9'3")	7.28 (23'11")	2.49 (8'2")	8.32 (27'4")	1527 (3400)
	(PCA)	02-02	90	14 810 (32,650)	1.99 (6'6")	2.73 (9'0")	7.41 (24'4")	2.59 (8'6")	8.765 (28'9")	1372 (3000)
314D CR	PDP(OSJ)	08-13	87	14 000	1.99	2.91	7.27	2.49	8.63	4250
	MFK(JPN)	08-12		(30,870)	(6'6")	(9'7")	(23'10")	(8'2")	(28'4")	(9100)
	WLN(OSJ)	10-14								
314D LCR	BYJ(OSJ)	08-13	87	14 100	1.99	2.91	7.27	2.49	8.63	4950
	SBP	08-09		(31,090)	(6'6")	(9'7")	(23'10")	(8'2")	(28'4")	(10,600)
	(SSZ)	10-12								
	TXN	10-12								
	XHR(OSJ)	10-14								

*When shipped with medium stick and bucket curled under.

**Maximum reach at ground level, one-piece boom, longest stick.

***Lift capacity at 4.6 m (15'0") over front, one-piece boom, longest stick.

Hydraulic Excavators (Track) (cont'd)

Model	Product Ident. No. Prefix COSA (US)	Years Built	Flywheel Horsepower	Approx. Operating Weight kg (lb)	Track Gauge m (ft)	Height* m (ft)	Length* m (ft)	Width m (ft)	Max. Reach** m (ft)	Lift Capacity*** kg (lb)
315	3ZM	95-98	99	15 920 (35,100)	1.99 (6'6")	2.88 (9'5")	8.5 (27'11")	2.49 (8'2")	8.21 (26'11")	5300 (11,700)
	4YM(OSJ)	94-97	99	16 330 (36,000)	1.99 (6'6")	2.88 (9'5")	8.5 (27'11")	2.49 (8'2")	9.14 (30'0")	5290 (11,700)
	6XM(JPN)	94-97	99	15 330 (33,800)	1.99 (6'6")	2.88 (9'5")	8.5 (27'11")	2.49 (8'2")	9.14 (30'0")	—
315 L	6YM(OSJ)	94-97	99	15 920 (35,100)	1.99 (6'6")	2.88 (9'5")	8.5 (27'11")	2.59 (8'6")	8.74 (28'8")	6320 (13,900)
315B	1SW(OSJ)	97-01	99	16 300 (35,940)	1.99 (6'6")	2.88 (9'5")	8.5 (27'11")	2.49 (8'2")	9.14 (30'0")	5500 (12,100)
	2DW(JPN)	97-01	99	15 850 (34,940)	1.99 (6'6")	2.88 (9'5")	8.5 (27'11")	2.49 (8'2")	9.14 (30'0")	—
315B L	5SW	98-	99	16 700 (36,820)	1.995 (6'7")	3.0 (9'10")	8.41 (27'7")	2.49 (8'2")	9.02 (29'7")	6720 (14,800)
	3AW(OSJ) 7RZ(forest) (OSJ) (CFB)	97-01	80/107	16 700 (36,820)	1.99 (6'6")	2.88 (9'5")	8.47 (27'10")	2.59 (8'6")	9.14 (30'0")	6600 (14,600)
315C	(CFB)	01-02	110	16 400 (36,160)	1.99 (6'6")	2.99 (9'10")	8.52 (27'11")	2.59 (8'6")	9.29 (30'6")	1675 (3700)
	CFL	01-	110	16 000 (35,270)	1.99 (6'6")	2.95 (9'8")	8.52 (27'11")	2.49 (8'2")	8.9 (29'2")	1840 (4100)
	AKE	03-07	110	16 399 (36,160)	1.99 (6'6")	2.88 (9'5")	8.5 (27'11")	2.49 (8'2")	9.14 (30'0")	5650 (12,100)
315C L	(CFT)	01-02	110	16 750 (36,930)	1.99 (6'6")	2.99 (9'10")	8.52 (27'11")	2.59 (8'6")	9.29 (30'6")	1719 (3800)
	CJC	03-07	110	16 748 (36,930)	1.99 (6'6")	2.88 (9'5")	8.5 (27'11")	2.59 (8'6")	9.14 (30'0")	6750 (14,450)
	ANF	03	83/111	16 770 (36,970)	1.99 (6'6")	2.76 (9'0")	8.39 (27'6")	2.49 (8'2")	9.09 (29'9")	7110 (15,675)
315D L	CJN(OSJ)	07-12	113	17 280	1.99	3.03	8.54	2.59	9.24	7100
	BYK(JPN)	07-11		(38,100)	(6'6")	(9'9")	(28'0")	(8'6")	(30'3")	(15,100)
	NCM	07-11								
	KBD	07-09								
	(JGS)	10-11								
	TLE	09-11								
317	4MM	95-98	99	17 260 (38,050)	2.15 (7'1")	2.88 (9'5")	8.5 (27'11")	2.75 (9'0")	8.62 (28'3")	4210 (9300)
	9WW	98-	81/109	17 300 (38,146)	2.2 (7'3")	3.04 (9'10")	8.41 (27'6")	2.8 (9'2")	9.1 (29'8")	7100 (15,655)
317 N	9SR	96-98	99	17 220 (37,960)	1.99 (6'6")	2.88 (9'5")	8.5 (27'11")	2.75 (9'0")	8.62 (28'3")	6450 (14,200)
317B LN	6DZ	98-	81/110	17 300 (38,146)	1.995 (6'5")	3.04 (9'10")	8.41 (27'6")	2.49 (8'2")	9.1 (29'8")	7100 (15,655)

*When shipped with medium stick and bucket curled under.

**Maximum reach at ground level, one-piece boom, longest stick.

***Lift capacity at 4.6 m (15'0") over front, one-piece boom, longest stick.

Hydraulic Excavators (Track) (cont'd)

Model	Product Ident. No. Prefix COSA (US)	Years Built	Flywheel Horsepower	Approx. Operating Weight kg (lb)	Track Gauge m (ft)	Height* m (ft)	Length* m (ft)	Width m (ft)	Max. Reach** m (ft)	Lift Capacity*** kg (lb)
318B L	9VW	98-	86/115	17 700 (39,020)	2.2 (7'3")	3.02 (9'11")	8.67 (28'5")	2.8 (9'2")	8.94 (29'4")	8440 (18,600)
	3LR(OSJ)	99-02	86/115	18 390 (40,540)	2.2 (7'3")	3.05 (10'0")	8.72 (28'7")	2.8 (9'2")	9.77 (32'0")	7650 (16,900)
	ADC	99-	86/115	18 500 (40,792)	2.2 (7'3")	3.04 (9'10")	8.69 (28'6")	2.8 (9'2")	9.6 (31'6")	7600 (16,760)
	(3LR)	01-02	86/115	18 360 (40,480)	2.2 (7'3")	2.83 (9'3")	8.69 (28'6")	2.8 (9'2")	9.78 (32'1")	2200 (4900)
318B LN	6DZ	98-	86/115	17 160 (37,830)	1.995 (6'7")	3.02 (9'11")	8.67 (28'5")	2.495 (8'2")	8.94 (29'4")	7590 (16,700)
	7KZ(OSJ)	99-02	86/115	18 260 (40,260)	2.2 (7'3")	3.05 (10'0")	8.72 (28'7")	2.59 (8'6")	9.77 (32'1")	7600 (16,800)
	AEJ	99-	86/115	18 500 (40,792)	1.995 (6'7")	3.04 (9'10")	8.69 (28'6")	2.49 (8'2")	9.6 (31'6")	7580 (16,710)
	(7KZ)	01-02	86/115	17 990 (39,660)	1.995 (6'7")	3.05 (10'0")	8.72 (28'7")	2.49 (8'2")	9.78 (32'1")	2200 (4900)
318C	BTG	03	94/127	19 560 (43,120)	2.2 (7'2")	2.9 (9'9")	8.9 (29'2")	2.8 (9'2")	9.66 (31'8")	7850 (17,305)
318C L	DAH(MDY)	02-07	94/127	20 160 (44,445)	2.2 (7'2")	2.9 (9'9")	8.9 (29'2")	2.8 (9'2")	9.66 (31'8")	8950 (19,730)
318C N	FAA(GPA)	02-07	94/127	19 280 (42,505)	1.99 (6'6")	2.9 (9'9")	8.9 (29'2")	2.49 (8'2")	9.66 (31'8")	7730 (17,040)
318D L	ZKJ(CHN)	12-13	113	17 620 (38,850)	1.99 (6'6")	3.03 (9'9")	8.54 (28'0")	2.59 (8'6")	8.96 (29'5")	6850 (14,700)
319C LN	KGL	04	94/127	20 080 (44,269)	1.99 (6'6")	2.9 (9'9")	8.9 (29'2")	2.49 (9'2")	9.66 (31'8")	7730 (17,040)
319D L	EAW(OSJ)	08-13	121	19 460 (42,910)	2.2 (7'3")	3.15 (10'4")	8.82 (28'11")	2.8 (9'2")	9.82 (32'3")	9150 (19,700)
	BZH	07-09								
	(ZCA)	10-12								
	ZGZ	09-11								
319D LN	AYF	11-12								
	KRM(OSJ)	11-13								
	FMH(OSJ)	08-13	121	19 170 (42,270)	1.99 (6'6")	3.15 (10'4")	8.82 (28'11")	2.49 (8'2")	9.82 (32'3")	9150 (19,700)
	DAY	08-09								
	(KFM)	10-12								
WBJ	09-11									
RJP	11-12									

*When shipped with medium stick and bucket curled under.

**Maximum reach at ground level, one-piece boom, longest stick.

***Lift capacity at 4.6 m (15'0") over front, one-piece boom, longest stick.

Hydraulic Excavators (Track) (cont'd)

Model	Product Ident. No. Prefix COSA (US)	Years Built	Flywheel Horsepower	Approx. Operating Weight kg (lb)	Track Gauge m (ft)	Height* m (ft)	Length* m (ft)	Width m (ft)	Max. Reach** m (ft)	Lift Capacity*** kg (lb)
320	7WK(OSJ) 2DL(OSJ) 8LG(OSJ) 7GJ(JPN) 3XM(JPN) 4ZJ(GOS)	91-96	128	19 120 (42,150)	2.2 (7'3")	2.93 (9'7")	9.37 (30'9)	2.8 (9'2")	10.63 (34'9")	6200 (17,700)
320 L	1TL(OSJ) 9KK(OSJ) 8HJ(JPN) 4JM(JPN) 3XK(GOS)	91-96	128	20 370 (44,910)	2.38 (7'10")	2.93 (9'7")	9.37 (30'9")	3.18 (10'5")	10.63 (34'9")	8150 (17,600)
320 N	1XM(OSJ) 9WG(GOS)	94-96	128	20 050 (44,150)	1.90 (6'6")	2.93 (9'7")	9.37 (30'9")	2.59 (8'6")	10.63 (34'9")	8150 (17,600)
320 S	6KM									
320B	3MR 5BR 1XS	96-00	128	19 400 (42,770)	2.2 (7'2.6")	3.01 (9'10.5")	9.46 (31'4")	2.8 (9'2.2")	10.77 (35'4")	8600 (19,000)
320B L	4MR 6CR 7JR	96-00	128	20 720 (45,680)	2.38 (7'9.7")	3.01 (9'10.5")	9.46 (31'4")	3.18 (10'5.2")	10.77 (35'4")	9200 (20,300)
320B N	4NR 2AS	96-00	128	19 930 (43,940)	2.2 (7'2.6")	3.01 (9'10.5")	9.46 (31'4")	2.5 (8'2.4")	10.77 (35'4")	9100 (20,100)
320B LN	3YZ	96-00	128							
320C	MAB	03-06	103	20 870 (46,010)	2.2 (7'3")	3.01 (9'11")	9.39 (30'10")	2.8 (9'2")	9.71 (31'10")	8810 (19,423)
320C L	ANB PAB TBR SAH	99-07	103	21 415 (47,212)	2.38 (7'10")	3.01 (9'11")	9.39 (30'10")	2.98 (9'9")	9.71 (31'10")	9550 (21,054)
320C U	MAC	03-05	103	22 300 (49,163)	2.2 (7'3")	3.01 (9'11")	8.73 (28'8")	2.8 (9'2")	9.86 (32'4")	9300 (20,503)
320C LU	PAC	02-07	103	23 000 (50,706)	2.38 (7'10")	3.01 (9'11")	8.92 (29'3")	2.98 (9'9")	9.86 (32'4")	9600 (21,164)
320D	AZR CXY EBT BWZ FAL A6F BZP JFZ SNS KLM KTF PCM KHN MZD	05-15	103	21 000 (46,300)	2.2 (7'3")	3.03 (9'10")	9.46 (31'0")	2.8 (9'2")	10 (32'10")	9000† (19,800)

*When shipped with medium stick and bucket curled under.

**Maximum reach at ground level, one-piece boom, longest stick.

***Lift capacity at 4.6 m (15'0") over front, one-piece boom, longest stick.

†Without bucket.

Hydraulic Excavators (Track) (cont'd)

Model	Product Ident. No. Prefix COSA (US)	Years Built	Flywheel Horsepower	Approx. Operating Weight kg (lb)	Track Gauge m (ft)	Height* m (ft)	Length* m (ft)	Width m (ft)	Max. Reach** m (ft)	Lift Capacity*** kg (lb)
320D L	BWP DHK MDE FNA DFB KGF A8F MGG PHX A9F WJN TDH SPN GDP KZF	05-15	103	21 900 (48,300)	2.38 (7'10")	3.03 (9'10")	9.46 (31'0")	2.98 (9'9")	10.0 (32'10")	10 250† (22,600)
320D LN	KAF WBN PCX	06-11	103	21 200 (46,700)	2.0 (6'7")	3.03 (9'10")	9.49 (31'2")	2.5 (8'2")	9.78 (32'1")	N/A
320D RR	AMR RBL GKL GMX YDS WFD	05-15	103	22 700 (50,045)	2.2 (7'3")	3.01 (9'11")	8.77 (28'9")	2.8 (9'2")	9.78 (32'1")	9050 (19,952)
320D LRR	CWN SCW FXK HJC EBY TAE XCK DHE ZGB EJT	05-15	103	23 300 (51,368)	2.38 (7'10")	3.01 (9'11")	8.96 (29'5")	2.98 (9'9")	9.78 (32'1")	10 600 (23,369)
321B CR	AKG(JPN)	98-01	128	19 400 (42,770)	2.2 (7'3")	3.1 (10'2")	8.6 (28'3")	2.98 (9'9")	9.68 (31'9")	8250 (18,200)
321B LCR	9CZ(JPN)	98-01	128	22 500 (49,600)	2.38 (7'10")	3.1 (10'2")	8.8 (28'11")	2.98 (9'9")	9.68 (31'9")	10 300 (22,700)
	KGA(OSJ)	02-02	128	23 100 (50,930)	2.38 (7'10")	3.1 (10'2")	8.8 (28'11")	2.98 (9'9")	9.68 (31'9")	10 300 (22,700)
321C CR	DAX	03-06	103	22 830 (50,332)	2.2 (7'3")	3.17 (10'5")	8.64 (28'4")	2.8 (9'2")	9.69 (31'9")	9050 (19,952)
321C LCR	KBB MCF KCR	02-07	103	24 000 (52,911)	2.38 (7'10")	3.17 (10'5")	8.83 (29'0")	2.98 (9'9")	9.69 (31'9")	11 000 (24,251)

*When shipped with medium stick and bucket curled under.

**Maximum reach at ground level, one-piece boom, longest stick.

***Lift capacity at 4.6 m (15'0") over front, one-piece boom, longest stick.

†Without bucket.

Hydraulic Excavators (Track) (cont'd)

Model	Product Ident. No. Prefix COA (US)	Years Built	Flywheel Horsepower	Approx. Operating Weight kg (lb)	Track Gauge m (ft)	Height* m (ft)	Length* m (ft)	Width m (ft)	Max. Reach** m (ft)	Lift Capacity*** kg (lb)
321D CR	JCX	07-14	103	23 000 (50,700)	2200 (7'3")	3.03 (9'11")	8.69 (28'6")	2.8 (9'2")	9.71 (31'10")	N/A
321D L CR	KBH KBZ MDT MPG NAS PBD TXA	07-15	103	23 780 (52,400)	2.38 (7'10")	3.03 (9'11")	8.83 (29'0")	2.98 (9'9")	9.71 (31'10")	11 150 (24,000)
322*	7WL(OSJ) 7WL(JPN)	93-96	153	22 650 (50,000)	2.39 (7'10")	3.12 (10'3")	9.95 (32'8")	2.99 (9'10")	10.47 (34'4")	10 400 (22,500)
322B	8MR 3NR	96-01 96-00	153	22 760 (50,180)	2.39 (7'10")	3.28 (10'9")	10.0 (32'10")	2.99 (9'10")	10.47 (34'4")	10 650 (23,500)
322 L*	8CL(OSJ) 8CL(JPN)	93-96	153	23 950 (52,800)	2.59 (8'6")	3.12 (10'3")	9.95 (32'8")	3.39 (11'1")	10.47 (34'4")	10 400 (22,500)
322B L	8NR 5CR	96-01 96-00	153	23 990 (52,890)	2.59 (8'6")	3.28 (10'9")	10.0 (32'10")	3.39 (11'1")	10.47 (34'4")	11 600 (25,600)
322C	DAA	03-05	121	23 000 (50,706)	2.39 (7'10")	3.12 (10'3")	9.96 (32'8")	2.99 (9'10")	10.01 (32'10")	10 750 (23,700)
322C L	BGR BFK FED	01-02 02-06 02-05	165	24 200 (53,400) 24 200 (53,352)	2.59 (8'6") 2.59 (8'6")	3.12 (10'3") 3.12 (10'3")	9.96 (32'8") 9.96 (32'8")	3.39 (11'1") 3.19 (10'6")	10.47 (34'4") 10.01 (32'10")	11 500 (24,900) 12 000 (26,455)
323D	WNE	10-11	110	22 200 (48,900)	2.2 (7'3")	3.12 (10'3")	9.46 (31'0")	2.8 (9'2")	9.83 (32'3")	N/A
323D L	PBM SDC BYM WGC JLG LFL PBE YSD NDE ZMF GTF NTF NZF	06-11	110	23 200 (51,100)	2.38 (7'10")	3.12 (10'3")	9.46 (31'0")	2.98 (9'9")	9.83 (32'3")	10 330 (22,800)
323D LN	CYD RAC CWG	05-11	110	23 200 (50,700)	2.0 (6'7")	3.12 (10'3")	9.46 (31'0")	2.5 (8'2")	9.83 (32'3")	10 330 (22,800)
323D S	DKW	05-07	103	22 500 (49,600)	1.9 (6'3")	3.1 (10'2")	9.46 (31'0")	2.5 (8'2")	9.44 (31'0")	N/A
323D SA	NES SED	06-11	110	23 500 (51,800)	1.9 (6'3")	3.12 (10'3")	9.5 (31'2")	2.5 (8'2")	9.98 (32'9")	10 360 (22,800)

*When shipped with medium stick and bucket curled under.

**Maximum reach at ground level, one-piece boom, longest stick.

***Lift capacity at 4.6 m (15'0") over front, one-piece boom, longest stick.

Hydraulic Excavators (Track) (cont'd)

Model	Product Ident. No. Prefix COSA (US)	Years Built	Flywheel Horsepower	Approx. Operating Weight kg (lb)	Track Gauge m (ft)	Height* m (ft)	Length* m (ft)	Width m (ft)	Max. Reach** m (ft)	Lift Capacity*** kg (lb)
324D	MND CJX JZR AWN	06-14	140	24 550 (54,100)	2.39 (7'10")	3.43 (11'3")	10.05 (34'5")	2.99 (9'10")	10.55 (34'7")	N/A
324D L	JAT SYM PYT GPK DFP TSN T2D LKN BTK JJG LAB BYE	06-14	140	25 870 (57,000)	2.59 (8'6")	3.43 (11'3")	10.05 (34'5")	3.39 (11'1")	10.55 (34'7")	11 400 (25,100)
324D LN	NPC TRH EJC	06-11	140	25 300 (55,800)	2.39 (7'10")	3.17 (10'5")	10.06 (33'0")	2.99 (9'10")	10.05 (34'5")	13 970 (30,800)
325*	5WK(OSJ) 8NL(OSJ) 8JG(JPN)	91-95	168	25 520 (56,270)	2.39 (7'10")	3.24 (10'8")	10.27 (33'8")	2.99 (9'10")	11.50 (37'7")	11 100 (24,000)
325 L*	5WK(JPN) 6KK(OSJ) 9KL(OSJ) 7CJ(JPN)	91-95	168	25 520 (56,270) 27 010 (59,560)	2.39 (7'10") 2.59 (8'6")	3.24 (10'8") 3.24 (10'8")	10.27 (33'8") 10.27 (33'8")	2.99 (9'10") 3.39 (11'1")	11.50 (37'7") 11.50 (37'7")	11 000 (24,000) 11 650 (25,150)
325B L	6KK(JPN) 6DN(GOS)	91-95	168	27 010 (59,560)	2.59 (8'6")	3.24 (10'8")	10.27 (33'8")	3.39 (11'1")	11.50 (37'7")	11 650 (25,150)
325B LN	8FN(GOS)	96-01	168	28 890 (63,690)	2.59 (8'6")	3.21 (10'6")	10.35 (33'11")	3.39 (11'1")	10.57 (34'8")	15 460 (34,080)
325C L	CBR CSJ	01-06	188	27 670 (61,000)	2.39 (7'10")	3.21 (10'6")	10.35 (33'11")	2.99 (9'10")	10.57 (34'8")	15 030 (33,140)
325D L	A3R	06-08	204	28 600 (63,100)	2.59 (8'6")	3.26 (10'8")	10.34 (33'11")	3.39 (11'1")	10.51 (34'6")	15 600 (33,750)
326D L	PJM	12-14	140	29 240 (64,460)	2.59 (8'6")	3.04 (10'0")	10.42 (34'2")	3.39 (11'1")	11.15 (36'7")	15 450 (33,400)
326D L	PJM	12-14	140	25 560 (56,400)	2.59 (8'6")	3.17 (10'5")	10.06 (33'0")	3.39 (11'1")	10.03 (32'11")	13 900 (30,600)
328D L CR	RMX JTC MKR GTN SWF BYH	06-15	152	36 200 (79,800)	2.59 (8'6")	3.37 (11'1")	9.82 (32'3")	3.44 (11'3")	10.56 (34'8")	12 300 (28,000)

*When shipped with medium stick and bucket curled under.

**Maximum reach at ground level, one-piece boom, longest stick.

***Lift capacity at 4.6 m (15'0") over front, one-piece boom, longest stick.

Hydraulic Excavators (Track) (cont'd)

Model	Product Ident. No. Prefix COSA (US)	Years Built	Flywheel Horsepower	Approx. Operating Weight kg (lb)	Track Gauge m (ft)	Height* m (ft)	Length* m (ft)	Width m (ft)	Max. Reach** m (ft)	Lift Capacity*** kg (lb)
329D	BBF	08-14	158	28 010	2.39	3.33	10.36	2.99	10.72	13 750
	WDK			(61,620)	(7'10")	(10'11")	(34'0")	(9'10")	(35'2")	(29,450)
	BYS									
	DTZ									
329D L	TAY	08-15	158	29 970	2.59	3.33	10.36	3.39	10.72	16 200
	MNB			(65,920)	(8'6")	(10'11")	(34'0")	(11'1")	(35'2")	(35,050)
	DJF									
	JHJ									
	BFC									
	LFW									
	RSK									
	TPM									
	J9D									
	J8D									
	L5G									
	L5H									
	TFW									
	XDB									
	CZF									
	WLT									
	TZL									
329D LN	SCY	08-11	152	28 860	2.39	3.18	10.41	2.99	10.6	13 050
	EBM			(63,600)	(7'10")	(10'5")	(34'2")	(9'10")	(34'9")	(28,800)
330*	9PJ(OSJ)	92-95	222	32 130	2.59	3.29	11.01	3.19	12.37	15 550
	8RL(OSJ)			(70,830)	(8'6")	(10'10")	(36'2")	(10'6")	(40'6")	(33,650)
	9NG(JPN)	92-95	222	32 130	2.59	3.29	11.01	3.19	12.37	15 550
	9PJ(JPN)			(70,830)	(8'6")	(10'10")	(36'2")	(10'6")	(40'6")	(33,650)
330 L*	6SK(OSJ)	92-95	222	33 510	2.59	3.29	11.01	3.34	12.37	14 600
	9ML(OSJ)			(73,880)	(8'6")	(10'10")	(36'2")	(10'11")	(40'6")	(31,500)
	6WJ(JPN)	92-95	222	33 510	2.59	3.29	11.01	3.34	12.37	14 600
	6SK(JPN)			(70,830)	(8'6")	(10'10")	(36'2")	(10'11")	(40'6")	(31,500)
330B L	3YR(GOS)	96-01	222	34 020	2.59	3.56	11.06	3.34	11.62	17 070
				(75,000)	(8'6")	(11'8")	(36'3")	(10'11")	(38'1")	(37,630)
330B LN	5LR(GOS)	96-01	222	33 860	2.39	3.56	11.06	2.99	11.62	17 070
				(74,650)	(7'10")	(11'8")	(36'3")	(9'10")	(38'1")	(37,630)
330C L	CAP	01-06	247	35 100	2.59	3.63	11.19	3.44	11.64	17 450
	CGZ			(77,400)	(8'6")	(11'11")	(36'9")	(11'3")	(38'2")	(37,750)
330D L	MWP	06-08	268	36 150	2.59	3.14	11.20	3.44	11.71	17 610
				(79,700)	(8'6")	(10'4")	(36'9")	(11'3")	(38'5")	(38,100)

*When shipped with medium stick and bucket curled under.

**Maximum reach at ground level, one-piece boom, longest stick.

***Lift capacity at 4.6 m (15'0") over front, one-piece boom, longest stick.

Hydraulic Excavators (Track) (cont'd)

Model	Product Ident. No. Prefix COSA (US)	Years Built	Flywheel Horsepower	Approx. Operating Weight kg (lb)	Track Gauge m (ft)	Height* m (ft)	Length* m (ft)	Width m (ft)	Max. Reach** m (ft)	Lift Capacity*** kg (lb)
345B	4SS	97-00	290	44 050 (97,100)	2.74 (9'0")	3.76 (12'4")	11.79 (33'8")	3.49 (11'5")	13.0 (42'8")	20 850 (45,000)
345B L	7KS(GOS) 2SW(GOS)	98-00	290	47 665 (105,080)	2.39 (7'10")	3.68 (12'1")	11.74 (38'6")	2.99 (9'10")	12.97 (42'6")	21 000 (46,300)
345B L Series II	CCC(VG) FEE(FG) DET(MH)	01-05	321	48 960 (107,960)	2.39 (7'10")	3.87 (12'8")	11.46 (37'7")	2.99 (9'10")	11.69 (38'4")	19 250 (42,450)
345C L	ELS(FG) GCL(VG)	05-08	325	50 500 (111,350)	2.39 (7'10")	3.74 (12'3")	11.84 (38'10")	2.99 (9'10")	11.70 (38'5")	20 100 (44,320)
345C L	LYS(FG) GPH(VG) FPC(VG)	05-08	325	50 500 (111,350)	2.39 (7'10")	3.74 (12'3")	11.84 (38'10")	2.99 (9'10")	11.70 (38'5")	20 100 (44,320)
345D	NEG AP ex ANZ/ CIS(AKA) BYW, FES CJL(AKA)		380	44 490 (98,084)	2.89 (9'6")	3.94 (13'0")	11.90 (39'1")	3.49 (11'5")	11.70 (38'5")	9050 (19,500)
345D L	PBT APD ex ANZ/ CIS/AME ex Turkey (AKA) RAE APD ex ANZ/ CIS(AKA) BYC ANZ(AKA) YEE LACD/AME ex Turkey (AUR) DPA, HLC CJL(AKA) EEH, RAJ NACD(AUR) RGG Euro/Turkey (GOS) RDC, MLK Euro/Turkey (GOS AUR) RBT, RGD AME ex Turkey (GOS)			47 200 (104,060)	2.89 (9'6")	3.94 (13'0")	11.90 (39'1")	3.49 (11'5")	11.70 (38'5")	9050 (19,500)

*When shipped with medium stick and bucket curled under.

**Maximum reach at ground level, one-piece boom, longest stick.

***Lift capacity at 4.6 m (15'0") over front, one-piece boom, longest stick.

Hydraulic Excavators (Track) (cont'd)

Model	Product Ident. No. Prefix COSA (US)	Years Built	Flywheel Horsepower	Approx. Operating Weight kg (lb)	Track Gauge m (ft)	Height* m (ft)	Length* m (ft)	Width m (ft)	Max. Reach** m (ft)	Lift Capacity*** kg (lb)
349D	MEN CIS/APD ex ANZ (AKA) GKF China (CXL)	11-14	380	44 490 (98,084)	2.89 (9'6")	3.94 (13'0")	11.9 (39'1")	3.49 (11'5")	11.7 (38'5")	9050 (19,500)
349D L	NNF CIS/APD ex ANZ (AKA) KLH China (CXL) PZG CIS/APD ex ANZ (AKA) WTD ANZ (AKA) JGB AME ex Turkey/ LACD (AUR) KHS AME ex Turkey (AUR) RBJ Turkey (AUR)	11-14	380	47 200 (104,060)	2.89 (9'6")	3.94 (13'0")	11.9 (39'1")	3.49 (11'5")	11.7 (38'5")	9050 (19,500)
350	7RK	93-99	286	48 040 (105,910)	2.55 (8'4.4")	3.75 (12'3.6")	12.2 (40'3")	3.2 (10'6")	13.45 (44'1.5")	17 750 (39,100)
	2ZL	93-99	286	50 094 (110,210)	2.55 (8'4.4")	3.75 (12'4")	12.2 (40'0")	3.3 (10'10")	13.49 (44'3")	17 750 (39,100)
350 L	9DK	93-99	286	49 010 (108,050)	2.55 (8'4.4")	3.75 (12'3.6")	12.2 (40'3")	3.3 (10'9.9")	13.45 (44'1.5")	17 750 (39,100)
	3ML	93-99	286	51 126 (112,450)	2.55 (8'4.4")	3.75 (12'4")	12.2 (40'0")	3.3 (10'10")	13.49 (44'3")	17 600 (40,900)
365B L	9PZ(GOS)	99-02	385	66 245 (146,050)	2.75 (9'0")	4.57 (15'0")	12.17 (39'11")	3.50 (11'6")	14.04 (46'1")	29 200 (64,370)
365B L Series II	JMB(EAME) DER(NACD) PEG(FS)	02-04	404	70 250 (154,900)	2.75 (9'0")	4.7 (15'5")	12.54 (41'2")	3.42 (11'3")	14.09 (16'3")	13 040 (28,750)

*When shipped with medium stick and bucket curled under.

**Maximum reach at ground level, one-piece boom, longest stick.

***Lift capacity at 4.6 m (15'0") over front, one-piece boom, longest stick.

Hydraulic Excavators (Track) (cont'd)

Model	Product Ident. No. Prefix COSA (US)	Years Built	Flywheel Horsepower	Approx. Operating Weight kg (lb)	Track Gauge m (ft)	Height* m (ft)	Length* m (ft)	Width m (ft)	Max. Reach** m (ft)	Lift Capacity*** kg (lb)
374D L	PJA Japan PAX Euro/Turkey PAP ADSD-N/ S.Korea PAS ADSD-S/ AME/CIS China/ANZ/ PAC Asia	Sep 2010	355 kW (476 hp)	71 132 (156,819) Reach Boom R3.6 (11'10") Stick 3.8 m ³ (5.0 yd ³) Bucket 650 mm (26 in) Shoe	2.75 (9'0") Shipping 3.41 (11'2") Working 2.75 (9'0")	4.48 (14'8") Reach Boom R3.6 (11'10") Stick 5.24 (17'2")	13.32 (43'8") Reach Boom R3.6 (11'10") Stick 14.29 (46'11")	3.5 (11'6") Transportation 750 mm (30 in) Shoe 3.48 (11'5")	14.23 (46'8") Reach Boom R4.67m (15'4") Stick 3.8 m ³ (5.0 yd ³) Bucket 15.61 (51'2")	17 300 (39,900) Reach Boom R4.67m (15'4") Stick 900 mm (36 in) Shoe Ground Level 4.5 m (15'0") Over Front 13 810 (30,450)
375	8WJ 6NK(GOS)	92-01 92-02	428	81 190 (178,800) 79 807 (175,940)	2.75 (9'0") 2.75 (9'0")	5.24 (17'2") 5.24 (17'2")	14.3 (46'11") 13.14 (43'1")	3.5 (11'6") 3.48 (11'5")	15.96 (52'4") 15.67 (51'5")	30 300 (65,600) 23 620 (52,070)
375 L	1JM 9WL(GOS)	93-01 92-02	428	82 380 (181,500) 80 700 (177,910)	2.94 (9'7") 2.75 (9'0")	5.24 (17'2") 5.24 (17'2")	14.3 (46'11") 14.29 (46'11")	3.84 (12'7") 3.48 (11'5")	15.96 (52'4") 15.67 (51'5")	29 550 (64,400) 23 620 (52,070)
385B L	FDL(EAME) RCD(NACD) CLS(EAME) MYA(NACD)	01-04	513	89 130 (196,530)	2.75 (9'0")	5.16 (16'11")	14.6 (47'11")	3.73 (12'3")	15.61 (51'2")	13 810 (30,450)
390D L	WAG Euro WBT ADSD-N/ ADSD-S S.Korea WAP AME/CIS/ ADSD-S APD	Nov 2010	390 kW (523 hp)	86 190 (190,016) GP Boom (27'7") R4.4m (14'5") Stick 4.6 m ³ (6.0 yd ³) HD Bucket 650 mm (26 in) Shoe	2.75 (9'0") Shipping 3.51 (11'6") Working 2.75 (9'0")	5.16 (16'11") GP Boom (27'7") GP3.4m (11'2") Stick 5.24 (17'2")	14.72 (48'4") GP Boom (27'7") GP3.4m (11'2") Stick 14.29 (46'11")	4.26 (14'0") Transportation 750 mm (30 in) Shoe 3.48 (11'5")	17.25 (56'7") Reach Boom R5.5m (18'1") Stick 3.9 m ³ (5.1 yd ³) Bucket 15.61 (51'2")	11 350 (25,900) Reach Boom R5.5m (18'1") Stick 900 mm (36 in) Shoe -1.5 m (-5.0 ft) 4.5 m (15'0") Over Front 13 810 (30,450)
5090B	CLD EAME SJY NACD	01-04	512	87 500 (192,937)	3.5 (11.51)	4.63 (15.19)	14.26 (46.77)	3.47 (11.38)	10.35 (33.95)	- -

*When shipped with medium stick and bucket curled under.

**Maximum reach at ground level, one-piece boom, longest stick.

***Lift capacity at 4.6 m (15'0") over front, one-piece boom, longest stick (6.1 m (20'0") over front for 375/375 L).



HYDRAULIC EXCAVATORS (Wheel)

Model	Product Ident. No. Prefix (USA)	Years Built	Flywheel Horsepower	Approx. Operating Weight kg (lb)	Height* m (ft)	Length* m (ft)	Width m (ft)	Max. Reach** m (ft)	Lift Capacity*** kg (lb)	Standard Tire Size
206	(2RC) (3GC)	84-90	Deutz-67 Perkins-71	12 185 (26,863)	3.11 (10'2")	7.38 (24'2.5")	2.40 (7'10")	8.14 (26'9")	3360 (7400)	Dual 9.00-20 12PR
212	(3JC) (5DC)	84-90	Deutz-84 Perkins-94	13 700 (30,423)	3.15 (10'4")	8.00 (26'3")	2.49 (8'2")	9.86 (32'4")	3850 (8490)	Dual 10.00-20 12PR
212B	(3PJ)	90-95	110	14 000 (30,870)	3.04 (10'0")	8.28 (27'2")	2.49 (8'2")	9.48 (31'1")	3900 (8600)	Dual 10.00-20 12PR
214	(9MB) (1KB)	84-88	Deutz-101 Perkins-102	15 600 (34,175)	3.06 (10'0")	8.28 (27'2")	2.49 (8'2")			Dual 10.00-20 12PR
214B	4CF	88-94	110	18 700 (41,230)	3.06 (10'0")	8.28 (27'2")	2.49 (8'2")	10.41 (34'2")	4200 (9260)	Dual 10.00-20 12PR
214B FT	9NF	88-94	135	18 700 (41,230)	3.06 (10'0")	8.28 (27'2")	2.49 (8'2")	10.41 (34'2")	4200 (9260)	Dual 10.00-20 12PR
224	(2JC) (5TC)	84-89	Deutz-143 Perkins-124	19 000 (41,890)	3.42 (11'3")	8.98 (29'6")	2.49 (8'2")	10.61 (34'10")	4800 (10,600)	Dual 10.00-20 12PR
224B	7WF	89-95	135	21 000 (46,297)	3.95 (13'0")	9.08 (29'9")	2.65 (8'8")	10.75 (35'3")	4800 (10,582)	Dual 11.00-20 14PR

*When shipped with medium stick and bucket curled under.

**Maximum reach at ground level, one-piece boom, longest stick.

***Lift capacity at 4.6 m (15'0") over front, one-piece boom, longest stick.

Hydraulic Excavators (Wheel) (cont'd)

Model	Product Ident. No. Prefix (USA)	Years Built	Flywheel Horsepower	Approx. Operating Weight kg (lb)	Height* m (ft)	Length* m (ft)	Width m (ft)	Max. Reach** m (ft)	Lift Capacity*** kg (lb)	Standard Tire Size
M312	6TL	96-02	114	13 425 (29,602)	3.07 (10'1")	8.62 (28'3")	2.5 (8'2")	8.9 (29'2")	4300 (9482)	10-20.00 14PR
M313C	H2A BDR	05-06 02-05	118	13 100-14 750 (28,886-35,524)	3.12 (10'2")	8.08 (26'6")	2.55 (8'4")	8.77 (28'9")	4800 (10,584)	10.00-20 16PR
M313D	J3A W3H	12-13 07-12	127	14 000-16 200 (30,870-35,721)	3.12 (10'3")	8.08 (26'6")	2.55 (8'4")	8.77 (28'10")	4800 (10,582)	10.00-20 16PR
M315	7ML	95-02	117	15 570 (34,332)	3.08 (10'1")	8.84 (29'0")	2.5 (8'2")	9.26 (30'5")	5100 (11,246)	10-20.00 14PR
M315C	H2B BDM	05-06 02-05	129	15 000-16 650 (33,075-36,713)	3.15 (10'4")	8.33 (27'4")	2.55 (8'4")	9.17 (30'1")	5600 (12,348)	10.00-20 16PR
M315D	J5B W5M	12-13 07-12	136	16 100-18 300 (35,501-40,352)	3.15 (10'4")	8.33 (27'4")	2.55 (8'4")	9.17 (30'1")	5700 (12,566)	10.00-20 16PR
M316C	H2C BDX	05-06 02-05	138	16 300-18 200 (35,942-40,131)	3.17 (10'5")	8.40 (27'7")	2.55 (8'4")	9.17 (30'1")	6500 (14,330)	10.00-20 16PR
M316D	D6W W6A	11-13 07-11	158	17 000-19 200 (37,478-42,329)	3.17 (10'5")	8.4 (27'7")	2.55 (8'4")	9.17 (30'1")	6400 (14,110)	10.00-20 16PR
M318	8AL	95-02	131	17 870 (39,403)	3.1 (10'2")	8.97 (29'5")	2.6 (8'6")	10.55 (34'7")	6400 (14,112)	10-20.00 14PR
M318C	H2D BCZ	05-06 02-05	151	17 800-19 700 (39,249-43,439)	3.21 (10'6")	8.96 (29'5")	2.55 (8'4")	9.60 (31'6")	6600 (14,550)	10.00-20 16PR
M318D	D8W W8P	11-13 07-11	166	18 200-20 100 (40,124-44,312)	3.17 (10'5")	8.96 (29'5")	2.55 (8'4")	9.6 (31'6")	6600 (14,550)	10.00-20 16PR
M320	6WL	97-02	131	20 200 (44,541)	3.21 (10'6")	9.55 (31'4")	2.75 (9'0")	11.18 (36'8")	7500 (16,538)	11-20.00 14PR
M322C	H2E BDK	05-06 02-05	164	20 500-22 700 (45,203-50,054)	3.25 (10'8")	9.64 (31'7")	2.75 (9'0")	10.32 (33'10")	7300 (16,093)	11.00-20 16PR
M322D	D2W W2S	11-13 07-11	164	20 500-22 500 (45,195-49,604)	3.20 (10'6")	9.64 (31'7")	2.75 (9'0")	10.32 (33'10")	7200 (15,873)	11.00-20 16PR

*When shipped with medium stick and bucket curled under, one-piece boom.

**Maximum reach at ground level, one-piece boom, longest stick.

***Lift capacity at 4.6 m (15'0") over front, rear dozer up, one-piece boom, longest stick.



5000 SERIES EXCAVATORS AND FRONT SHOVELS

Model	Product Ident. No. Prefix COSA (US)	Years Built	Flywheel Horsepower	Approx. Operating Weight kg (lb)	Track Gauge m (ft)	Height* m (ft)	Length* m (ft)	Width m (ft)	Max. Reach** m (ft)	Lift Capacity*** kg (lb)
5080	6XK(GOS)	94-02	428	83 800 (184,750)	2.75 (9'0")	4.73 (15'6")	13.76 (45'2")	3.48 (11'5")	9.76 (32'0")	—
5090B	CLD(EAME) SJY(NACD)	01-04	512	87 500 (192,940)	3.51 (11'6")	4.63 (15'2")	14.26 (46'9")	3.47 (11'5")	10.35 (33'11")	—

*When shipped with medium stick and bucket curled under.

**Maximum reach at ground level, one-piece boom, longest stick.

***Lift capacity at 4.6 m (15'0") over front, one-piece boom, longest stick.

Model	Product Ident. No. Prefix (USA)	Years Built	Flywheel Horsepower	Approx. Operating Weight kg (lb)	Rated* Capacity m ³ (yd ³)	Breakout Force kN (lb)	Crowd Force kN (lb)	Track Gauge m (ft)	Max. Reach* m (ft)	Max. Load Height m (ft)	Max. Digging Depth m (ft)
5110B ME	AAA	00-03	696	127 000 (280,000)	7.6 (9.9)	501 (112,600)	439 (98,800)	4.1 (13.4')	13.9 (45.7')	8.6 (28.0')	7.9 (25.9')
5110B L	AAK	02-03	696	129 000 (284,000)	4.6 (6.0)	463 (104,175)	377 (84,825)	4.1 (13.4')	16.39 (53.8')	10.06 (33.0')	10.51 (34.5')
5130 ME	5ZL	92-97	755	180 000 (397,000)	10.0 (13.0)	615 (138,400)	624 (140,300)	4.72 (15'6")	14.9 (48'11")	9.1 (29'10")	8.4 (27'7")
5130 FS	5ZL	92-97	755	179 000 (395,000)	10.5 (13.7)	715 (161,000)	770 (173,000)	4.72 (15'6")	12.4 (40'8")	9.1 (29'10")	—
5130B ME	4CS	97-03	800	182 000 (401,000)	10.5 (13.7)	672 (151,100)	624 (140,300)	4.72 (15.5')	14.9 (48.9')	9.1 (29.8')	8.4 (27.6')
5130B FS	4CS	97-03	800	181 000 (399,000)	11.0 (14.5)	715 (161,000)	770 (173,000)	4.72 (15.5')	12.4 (40.7')	9.1 (29.8')	—
5230 ME	7LL	94-00	1470	316 600 (698,000)	16.0 (21.0)	873 (196,260)	874 (196,480)	5.2 (17'0")	17.7 (58'0")	9.8 (32'2")	9.4 (30'10")
5230 FS	7LL	94-00	1470	318 422 (702,000)	17.0 (22.2)	1125 (253,000)	1250 (281,000)	5.2 (17'0")	14.8 (48'7")	10.3 (33'10")	—
5230B ME	4HZ	01-04	1550	328 100 (723,400)	16.0 (21.0)	855 (192,083)	885 (198,848)	5.196 (17.0')	17.8 (58.4')	9.8 (32.0')	9.5 (31.3')
5230B FS	4HZ	01-04	1550	327 000 (721,000)	17.0 (22.2)	1162 (261,145)	1145 (257,324)	5.196 (17.0')	14.9 (48.8')	10.4 (34.1')	—

*Standard boom and stick.



WHEEL MATERIAL HANDLERS

Model	Product Ident. No. Prefix	Years Built	Flywheel Horsepower kW (hp)	Approx. Operating Weight kg (lb)	Max. Reach m (ft)	Lift Capacity* kg (lb)
M318 MH	6ES	98-02	104 (140)	19 500 (43,000)	10.5 (34'8")	2100 (4630)
	8SS	98-02	104 (140)	19 500 (43,000)	10.5 (34'8")	2100 (4630)
M318C MH	BEB	02-05	113 (151)	21 460 (47,311)	11.0 (36'1")	2100 (4630)
	H2F	05-06	113 (151)	21 460 (47,311)	11.0 (36'1")	2100 (4630)
M318D MH	D9X	11-13	124	18 200-20 100	11.0	2150
	W8R	07-11	(166)	(40,124-44,312)	(36'1")	(4740)
M320 MH	9PS	98-02	104 (140)	21 150 (46,600)	11.6 (38'0")	3200 (7055)
M322C MH	BDY	02-05	122 (164)	24 690 (54,432)	12.5 (41'0")	2300 (5070)
	H2G	05-06	122 (164)	24 690 (54,432)	12.5 (41'0")	2300 (5070)
M322D MH	D3X	11-13	122	20 500-22 500	12.5	2050
	W2T	07-11	(164)	(45,195-49,604)	(41'0")	(4519)
325 WMH	2SL	98	125 (168)	35 100 (77,400)	13.4 (43'11")	4200 (9400)
325B WMH	2JR	98	132 (177)	34 958 (77,000)	13.4 (43'11")	4700 (10,400)
M325B MH	2JR	99-00	125 (168)	37 200 (82,040)	15.5 (50'10")	3040 (6700)
	BGN	01-04	125 (168)	37 200 (82,040)	15.5 (50'10")	3040 (6700)
M325C MH	XJA	03-06	128 (173)	31 500 (69,450)	15.65 (51'4")	2960 (6526)
M325C LMH	PAN	03-06	140 (189)	37 000 (81,570)	15.65 (51'4")	3510 (7738)
W330B MH	AME	00-02	165 (222)	52 800 (116,300)	14.4 (47'3")	4800 (10,700)
W345B MH	ANJ	02	216 (290)	64 250 (141,650)	16.5 (54'0")	5300 (11,800)
	CDY	02-04	239 (321)	66 040 (145,288)	16.5 (54'0")	5300 (11,800)
W345C MH	R5K	05	257 (345)	64 745 (142,740)	18.0 (59'1")	5150 (11,400)
350 WMH	9FL	98	213 (286)	68 812 (151,800)	17.1 (56'3")	6300 (13,889)
	3ML	99	213 (286)	68 812 (151,800)	17.1 (56'3")	6300 (13,889)

*Lift at maximum reach over front at 3 m (10 ft) elevation from stick pin, no tool.



TRACK MATERIAL HANDLERS

Model	Product Ident. No. Prefix	Years Built	Flywheel Horsepower kW (hp)	Approx. Operating Weight kg (lb)	Max. Reach m (ft)	Lift Capacity* kg (lb)
320 MH	3XK	-99	96 (128)	23 030 (50,670)	12.4 (40'8")	2910 (6400)
	9KK	-99	96 (128)	23 030 (50,670)	12.4 (40'8")	2910 (6400)
320B MH	6LS	99-01	100 (134)	23 030 (50,670)	12.4 (40'8")	3150 (6900)
320C MH	BGB	01-02	103 (138)	25 530 (56,283)	12.4 (40'8")	3150 (6900)
	SAH	03-07	103 (138)	25 530 (56,283)	12.4 (40'8")	3150 (6900)
325 MH	2SL	-98	125 (168)	31 400 (69,237)	13.4 (43'11")	4130 (9100)
325B MH	2JR	98-02	132 (177)	33 236 (73,120)	13.4 (43'11")	4200 (9200)
325C MH	S2C	03-05	140 (188)	34 630 (76,350)	15.5 (50'10")	3000 (6600)
325D MH	RJK	05-12	152 (204)	35 526 (78,321)	15.5 (50'11")	3010 (6630)
	C4H	05-12	152 (204)	35 526 (78,321)	15.5 (50'11")	3010 (6630)
330 MH	5YM	-98	166 (222)	39 100 (86,215)	14.4 (47'3")	4080 (9000)
330B MH	6DR	98-02	165 (222)	41 430 (91,350)	14.4 (47'3")	4900 (10,800)
330C MH	D3C	03-05	184 (247)	43 815 (96,595)	15.9 (52'2")	3900 (8600)
330D MH	LEM	05-13	200 (268)	44 627 (98,386)	16.0 (52'6")	3670 (8090)
	C5K	05-13	200 (268)	44 627 (98,386)	16.0 (52'6")	3670 (8090)
345B MH	2NW	97-00	216 (290)	55 705 (122,550)	16.5 (54'0")	5300 (11,600)
345BII MH	APB	00-05	239 (321)	56 100 (123,420)	16.5 (54'0")	5300 (11,600)
345C MH	M2R	05-13	257 (345)	57 431 (126,615)	18.0 (59'1")	5000 (11,000)
	D3S	05-13	257 (345)	57 431 (126,615)	18.0 (59'1")	5000 (11,000)
350 MH	8KZ	-00	213 (286)	61 576 (135,630)	17.1 (56'3")	5350 (11,800)
	9FL	-00	213 (286)	61 576 (135,630)	17.1 (56'3")	5350 (11,800)
365B MH	CTY	02-03	287 (385)	74 470 (164,177)	18.9 (61'11")	6320 (13,540)
365BII MH	SDL	04	302 (404)	74 470 (164,177)	18.9 (62'3")	6320 (13,540)
365C MH	GWC	05-06	302 (404)	79 263 (174,744)	19.8 (65'1")	5400 (11,905)
375 MH	8SL	00	319 (428)	92 081 (203,000)	21.1 (69'3")	5900 (13,200)
	1JM	00-05	319 (428)	92 081 (203,000)	21.1 (69'3")	5900 (13,200)

*Lift at maximum reach over front at 3 m (10 ft) elevation from stick pin, no tool.



LOGGING AND FOREST PRODUCT MACHINES

Model	Product Ident. No. Prefix	Years Built	Flywheel Power kW (hp)	Overall Track Length m (ft)	Overall Length m (ft)	Overall Width m (ft)	Operating Weight kg (lb)
320B Stroke Delimber	9JS	—	96 (128)	—	11.96 (39'3")	3.66 (12'0")	30 390 (67,000)
FB221	8XD	1986	147 (197)	4.47 (14'8")	9.78 (32'1")	3.20 (10'6")	28 180 (62,000)
FB227	10W	1983-93	100/134 (135/180)	4.55 (14'11")	11.88 (39'0")	3.35 (11'0")	31 769 (69,892)
DL221	8YD	1987	98 (132)	4.47 (14'8")	—	—	22 816 (50,300)
LL216	8JD	1986	95 (128)	—	10.70 to 11.23 (35'1" to 36'10")	2.64 (8'8")	17 577 (38,750)
LL228	8MD	1986	131 (176)	—	9.7 to 11.6 (32'0" to 38'0")	2.62 (8'7")	30 391 (67,000)
LL231	8PD	1986	175 (235)	5.03 (16'6")	10.6 to 11.6 (35'0" to 38'0")	3.56 (11'8")	39 146 (86,300)
320B LL	6LS/9JS	96-01	96 (128)	4.48 (14'8")	—	3.29 (10'10")	28 610 (63,100)
320C LL	BGB/BKK	01-03	96 (128)	4.5 (14'8")	—	3.3 (10'10")	25 900 (57,100)
320C LL	SAH/TBR	02-07	103 (138)	4.6 (14'9")	—	3.3 (10'10")	27 200 (59,965)
320D LL	GKS	07-14	110 (147)	4.6 (14'9")	—	3.3 (10'10")	30 300 (66,812)
320D GF	BZF/EAX	06-14	110 (147)	4.6 (14'9")	—	3.3 (10'10")	26 900 (59,315)
322B LL	1YS	96-02	114 (153)	4.66 (15'3")	—	3.72 (12'3")	32 970 (72,686)
322C FM GF (HD/LC)	BPH	01-06	125 (168)	4.66 (15'4")	9.96 (32'8")	3.29 (10'10")	28 229 (62,245)*
322C FM GF (HW)	CAM	01-06	125 (168)	4.69 (15'5")	9.91 (32'6")	3.62 (11'11")	30 710 (67,716)*
322C FM LL (U/U)	CBY	01-06	125 (168)	4.69 (15'5")	14.10 (46'3")	3.62 (11'11")	33 607 (74,103)*
322C FM LL (O/U)	CBY	01-06	125 (168)	4.69 (15'5")	15 (49'3")	3.62 (11'11")	33 896 (74,741)*

*Operating Weight without bucket or grapple and with the new FM Cab/Riser with integrated guarding (available in July 2004).

Logging and Forest Product Machines (cont'd)

Model	Product Ident. No. Prefix	Years Built	Flywheel Power kW (hp)	Overall Track Length m (ft)	Overall Length m (ft)	Overall Width m (ft)	Operating Weight kg (lb)
324D FM LGP	JGK	07-10	140 (188)	4.7 (15.3)	13 (42.7)	3.62 (11.9)	32 886 (72,500)
325B LL	2JR	96-01	124 (166)	4.66 (15'3")	—	3.62 (11'11")	36 916 (81,400)
325C FM GF (HD/LC)	G1L	02-06	140 (188)	4.70 (15'5")	10.34 (33'11")	3.44 (11'3")	31 942 (70,432)*
325C FM GF (HW)	M2K	02-06	140 (188)	4.70 (15'5")	10.29 (33'9")	3.62 (11'11")	33 078 (72,937)*
325C FM LL (U/U)	S3M	02-06	140 (188)	4.70 (15'5")	14.87 (48'9")	3.62 (11'11")	37 644 (83,005)*
325C FM LL (O/U)	S3M	02-06	140 (188)	4.70 (15'5")	15.75 (51'8")	3.62 (11'11")	38 219 (84,273)*
330B LL	6DR	96-02	160 (214)	5.02 (16'6")	—	3.62 (11'11")	44 172 (97,400)
330C FM GF (HD/LC)	B3M	02-06	184 (247)	5.08 (16'8")	11.19 (36'9")	3.52 (11'6")	39 347 (86,760)*
330C FM GF (HW)	B4N	02-06	184 (247)	5.07 (16'7")	11.19 (36'9")	3.62 (11'11")	40 778 (89,915)*
330C FM LL (U/U)	B1K	02-06	184 (247)	5.07 (16'7")	16.67 (54'8")	3.62 (11'11")	44 430 (97,968)*
330C FM LL (O/U)	B1K	02-06	184 (247)	5.07 (16'7")	17.36 (57'0")	3.62 (11'11")	44 965 (99,148)*
330D FM GF	L2K	06-10	200 (268)	5.06 (16'7")	111.15 (367'7")	3.65 (11'11")	41 426 (91,344)
330D FM LL (U/U)	H3K	06-10	200 (268)	5.06 (16'7")	166.3 (547'7")	3.65 (11'11")	45 801 (100,991)
330D FM LL (O/U)	H3K	06-10	200 (268)	5.06 (16'7")	173.2 (567'10")	3.65 (11'11")	46 261 (102,005)

*Operating Weight without bucket or grapple and with the new FM Cab/Riser with integrated guarding (available in July 2004).



WHEEL SKIDDERS

Model	Product Ident. No. Prefix	Years Built	Flywheel Horsepower kW (hp)	Operating Weight kg (lb)	Ground Clearance mm (in)	Wheel Base m (ft/in)
508 Cable	9NC	87-89	71 (95)	7770 (17,130)	521 (20.5)	2.8 (9'2")
508 Grapple	2HD	87-89	71 (95)	8766 (19,308)	521 (20.5)	2.8 (9'2")
518 FB	8ZC	86-89	96 (130)	11 612 (25,600)	587 (23.1)	3.25 (10'8")
518 PS Cable	50S	71-83	90 (120)	7718 (17,000)	505.4 (19.8976)	2895.6 (9'6")
518 PS Grapple	55U	1-80/81-83	90/97 (120/130)	9307 (20,500)	505.4 (19.8976)	2895.6 (9'6")
518 Cable	94U	3-84/85-92	90/97 (120/130)	9988 (22,000)	470 (18.5039)	3251 (10'8.4")
518 Grapple	95U	81-90	97 (130)	11 259 (24,800)	470 (18.5039)	3251 (10'8.4")
518 Series II Cable	94U	91-92	dual 97/108 dual (130/145)	10 260 (22,600)	470 (18.5039)	3251 (10'8.4")
518 Series II Grapple	95U	91-92	dual 97/108 dual (130/145)	12 031 (26,500)	470 (18.5039)	3251 (10'8.4")
518C Cable	1CL	93-95	115 (154)	11 528 (25,391)	450.7 (17.74406)	3251 (10'8.4")
518C Grapple	9HJ	93-95	115 (154)	12 587 (27,725)	463.4 (18.24406)	3251 (10'8.4")
525	—	—	119 (160)	13 558 (29,891)	527 (20.7)	3.5 (11.5)
525B	—	02-06	119 (160)	18 325 (40,400)	463 (18.2)	3.5 (11.5)
525C	—	06-14	146 (196)	17 711 (39,045)	581 (22.9)	3534 (11'7")
535B	—	6-Feb	134 (180)	19 006 (41,900)	463 (18.2)	3.5 (11.5)
535C	—	06-14	162 (218)	18 044 (39,780)	581 (22.9)	3534 (11'7")
545 Grapple	—	6-Feb	149.1 (225)	20 230 (44,600)	606.4 (23.9)	3.8 (12.5)
545C	—	06-14	173 (232)	19 198 (42,325)	581 (22.9)	3939 (12'11")



TRACK SKIDDERS

Model	Product Ident. No. Prefix	Years Built	Flywheel Horsepower kW (hp)	Operating Weight kg (lb)	Gauge m (ft/in)
D4TSK Series II	8ZF	90-92	78 (105)	12 909 (28,400)	2.00 (6'6")
D4TSK Series III	7PK	92-96	78 (105)	14 000 (30,900)	2.00 (6'6")
D5HTSK Series II	7EG	92-96	97 (130)	18 800 (41,360)	2.16 (7'11")

Former Models

Track Feller Bunchers
 Forwarders
 Track Harvester
 Wheel Harvester



TRACK FELLER BUNCHERS

Model	Product Ident. No. Prefix	Years Built	Gross Power kW (hp)	Overall Track Length m (ft)	Overall Length m (ft)	Overall Width m (ft)	Operating Weight kg (lb)
511	511	06-12	184.2 (247)	4.6 (15.0)	8.5 (27.7)	3.2 (10.5)	24 362 (53,710)
521	521	06-12	211.8 (284)	4.8 (15.8)	8.6 (28.3)	3.2 (10.5)	27 084 (59,710)
522	522	06-12	211.8 (284)	4.8 (15.8)	8.6 (28.3)	3.5 (11.4)	30 410 (67,040)
532	532	06-12	211.8 (284)	4.9 (16.1)	8.6 (28.3)	3.5 (11.4)	31 620 (69,710)
541	541	06-11	227.4 (305)	4.9 (16.1)	9.4 (30.9)	3.6 (11.8)	30 191 (66,560)
551	551	06-11	227.4 (305)	4.9 (16.1)	9.4 (30.9)	3.6 (11.8)	31 057 (68,468)
552	552	06-11	227.4 (305)	4.9 (16.1)	9.4 (30.9)	3.6 (11.8)	35 680 (78,660)



FORWARDERS

Model	Product Ident. No. Prefix	Years Built	Number of Wheels	Engine	Gross Power kW (hp)	Operating Weight kg (lb)	Load Capacity kg (lb)	Transmission	Std. Wheel Base mm (in)
534	HF	06-11	4	C4.4 ACERT	93 (125)	12 247 (27,000)	7258 (16,000)	Electric Powershift	3835 (151)
544	HF	06-11	6	C4.4 ACERT	93 (125)	14 062 (31,000)	10 866 (24,000)	Electric Powershift	5334 (210)
584	PAK	09-14	8	C7 ACERT	204 (274)	22 498 (49,600)	18 000 (39,683)	2 Speed Hydrostatic	6096 (240)



TRACK HARVESTER

Model	Product Ident. No. Prefix	Years Built	Engine	Gross Power kW (hp)	Track Pitch mm (in)	Overall Height m (ft)	Overall Width m (ft)	Operating Weight kg (lb)
501	PH	06-12	C6.6 ACERT	122 (163)	171.4 (6.7)	3.33 (11.9)	2.59 (8.5)	15 900 (35,000)



WHEEL HARVESTER

Model	Product Ident. No. Prefix	Years Built	Number of Wheels	Engine	Gross Power kW (hp)	Transmission	Boom Reach m (ft)	Std. Wheel Base mm (in)	Operating Weight kg (lb)
550	PH	06-13	6	C7 ACERT	147 (197)	Hydrostatic	8.2 (27)	4160 (164)	21 319 (47,040)



BACKHOE LOADERS

Model	Product Ident. No. Prefix	Years Built	Flywheel Horsepower kW (hp)	Operating Weight kg (lb)	Digging Depth mm (ft/in)	GP Bucket Capacity m ³ (yd ³)	MP Bucket Capacity m ³ (yd ³)
416	5PC	85-90	46 (62)	6156 (13,574)	4420 (14'6")	0.76 (1.0)	0.76 (1.0)
416 Series II	5PC	90-92	46 (62)	6217 (13,708)	4420 (14'6")	0.76 (1.0)	0.76 (1.0)
416B	8ZK(8SG)	92-95	59 (79)	6227 (13,700)	4420 (14'6")	0.76 (1.0)	0.96 (1.25)
416C	4ZN(5YN)	96-00	56 (75)	6330 (13,957)	4420 (14'6")	0.76 (1.0)	0.96 (1.25)
416C (IT)	1WR(1XR)	96-00	56 (75)	6666 (14,698)	4420 (14'6")	0.96 (1.25)	0.96 (1.25)
416D	BFP, BKG, BGJ, CXP	00-05	58 (78)	6900 (15,257)	4390 (14'5")	0.76 (1.0)	0.96 (1.25)
420D	FDP, BKC	00-05	69 (93)	7150 (15,772)	4390 (14'5")	0.96 (1.25)	0.96 (1.25)
420D (IT)	BLN, BMC, MBH	00-05	69 (93)	7150 (15,772)	4390 (14'5")	0.96 (1.25)	0.96 (1.25)
424D	RXA, CJZ	01-05	56 (75)	7502 (16,539)	4854 (15'9")	1.0 (1.31)	0.96 (1.25)
426	7BC	86-90	52 (70)	6549 (14,626)	4720 (15'6")	0.96 (1.25)	0.76 (1.0)
426 Series II	7BC	90-92	52 (70)	7315 (15,126)	4720 (15'6")	0.96 (1.25)	0.76 (1.0)
426B	6KL(5YJ)	92-95	59 (79)	6790 (14,970)	4720 (15'6")	0.96 (1.25)	0.96 (1.25)
426C	6XN(7WN)	96-98	60 (80)	7051 (15,548)	4721 (15'6")	0.96 (1.25)	0.96 (1.25)
426C	6XN3616 and up (7WN939 and up)	99-00	63 (85)	7051 (15,548)	4721 (15'6")	0.96 (1.25)	0.96 (1.25)
(AWS) 426C	1CR(1ER)	96-98	60 (80)	7051 (15,548)	4721 (15'6")	0.96 (1.25)	0.96 (1.25)
(AWS) 426C	1CR864 and up (1ER864 and up)	99-00	63 (85)	7051 (15,548)	4721 (15'6")	0.96 (1.25)	0.96 (1.25)
426C (IT)	1YR(1ZR)	96-98	60 (80)	7387 (16,289)	4721 (15'6")	0.96 (1.25)	0.96 (1.25)
426C (IT)	1YR1517 and up (1ZR926 and up)	99-00	63 (85)	7387 (16,289)	4721 (15'6")	0.96 (1.25)	0.96 (1.25)
(AWS) 426C (IT)	1MR(1NR)	96-98	60 (80)	7387 (16,289)	4721 (15'6")	0.96 (1.25)	0.96 (1.25)
(AWS) 426C (IT)	1MR956 and up (1NR954 and up)	99-00	63 (85)	7387 (16,289)	4721 (15'6")	0.96 (1.25)	0.96 (1.25)

Backhoe Loaders (cont'd)

Model	Product Ident. No. Prefix	Years Built	Flywheel Horsepower kW (hp)	Operating Weight kg (lb)	Digging Depth mm (ft/in)	GP Bucket Capacity m ³ (yd ³)	MP Bucket Capacity m ³ (yd ³)
428	6TC	86-90	52 (70)	6963 (15,350)	4790 (15'9")	1.0 (1.31)	0.92 (1.2)
428 Series II	6TC	90-92	52 (70)	7143 (15,750)	4750 (15'7")	1.0 (1.31)	0.92 (1.2)
428B	7EJ	92-95	60 (80)	7254 (15,992)	4810 (15'9")	1.0 (1.31)	0.92 (1.2)
428C	8RN	96-00	56 (75)	7279 (16,047)	4811 (15'9")	1.0 (1.31)	1.03 (1.35)
428C (IT)	2CR	96-00	56 (75)	7615 (16,788)	4811 (15'9")	1.0 (1.31)	1.03 (1.35)
428D	DSX, BXC, MBM	01-05	61 (82)	7738 (17,059)	4854 (15'9")	1.0 (1.31)	1.03 (1.35)
430D	BNK	00-05	75 (101)	7355 (16,217)	4639 (15'3")	1.0 (1.31)	0.96 (1.25)
430D (IT)	BML	00-05	75 (101)	7355 (16,217)	4639 (15'3")	1.0 (1.31)	0.96 (1.25)
432D	TDR, WEP	01-05	69 (93)	7809 (17,216)	4854 (15'9")	1.0 (1.31)	1.03 (1.35)
436	5KF	88-90	57 (77)	6831 (15,062)	4960 (16'3")	0.76 (1.0)	0.76 (1.0)
436 Series II	5KF	90-92	57 (77)	6878 (15,166)	4950 (16'3")	0.76 (1.0)	0.76 (1.0)
436B	7FL(6MJ)	92-95	63 (84)	6857 (15,086)	4950 (16'3")	0.96 (1.25)	0.96 (1.25)
436C	8TN(9JN)	96-98	63 (85)	7118 (15,694)	4953 (16'3")	1.0 (1.31)	0.96 (1.25)
436C	8TN925 and up (9JN884 and up)	99-00	70 (93)	7118 (15,694)	4953 (16'3")	1.0 (1.31)	0.96 (1.25)
(AWS) 436C	1FR(1GR)	96-98	63 (85)	7118 (15,694)	4953 (16'3")	1.0 (1.31)	0.96 (1.25)
(AWS) 436C	1FR1416 and up (1GR916 and up)	99-00	70 (93)	7118 (15,694)	4953 (16'3")	1.0 (1.31)	0.96 (1.25)
436C (IT)	2AR(2BR)	96-98	63 (85)	7454 (16,435)	4953 (16'3")	1.0 (1.31)	0.96 (1.25)
436C (IT)	2AR1604 and up (2BR911 and up)	99-00	70 (93)	7454 (16,435)	4953 (16'3")	1.0 (1.31)	0.96 (1.25)
(AWS) 436C (IT)	1PR(1RR)	96-98	63 (85)	7454 (16,435)	4953 (16'3")	1.0 (1.31)	0.96 (1.25)
(AWS) 436C (IT)	1PR1599 and up (1RR998 and up)	99-00	70 (93)	7454 (16,435)	4953 (16'3")	1.0 (1.31)	0.96 (1.25)

Backhoe Loaders (cont'd)

Model	Product Ident. No. Prefix	Years Built	Flywheel Horsepower kW (hp)	Operating Weight kg (lb)	Digging Depth mm (ft/in)	GP Bucket Capacity m ³ (yd ³)	MP Bucket Capacity m ³ (yd ³)
438	3DJ	88-90	63 (84)	7900 (17,420)	4810 (15'9")	1.0 (1.31)	0.92 (1.2)
438 Series II	3DJ	90-92	57 (77)	7364 (16,237)	4810 (15'9")	1.0 (1.31)	0.92 (1.2)
438B	3KK	92-95	62.7 (84)	8331 (18,367)	4870 (16'0")	1.0 (1.31)	0.92 (1.2)
438C	9KN	96-98	63 (85)	7384 (16,279)	4873 (16'0")	1.0 (1.31)	1.03 (1.35)
438C	9KN1061 and up	99-00	70 (93)	7384 (16,279)	4873 (16'0")	1.0 (1.31)	1.03 (1.35)
(AWS) 438C	1JR	96-98	63 (85)	7384 (16,279)	4873 (16'0")	1.0 (1.31)	1.03 (1.35)
(AWS) 438C	1JR1107 and up	99-00	70 (93)	7384 (16,279)	4873 (16'0")	1.0 (1.31)	1.03 (1.35)
438C (IT)	2DR	96-98	63 (85)	7720 (17,020)	4873 (16'0")	1.0 (1.31)	1.03 (1.35)
438C (IT)	2DR2717 and up	99-00	70 (93)	7720 (17,020)	4873 (16'0")	1.0 (1.31)	1.03 (1.35)
(AWS) 438C (IT)	1TR	96-98	63 (85)	7720 (17,020)	4873 (16'0")	1.0 (1.31)	1.03 (1.35)
(AWS) 438C (IT)	1TR1284 and up	99-00	70 (93)	7720 (17,020)	4873 (16'0")	1.0 (1.31)	1.03 (1.35)
442D	SMJ, TBD	01-05	75 (101)	7809 (17,216)	4854 (15'9")	1.0 (1.31)	1.03 (1.35)
446	6XF	89-95	71 (95)	8892 (19,603)	5220 (17'2")	1.15 (1.5)	1.10 (1.5)
446B			76 (102)	8890 (19,600)	5220 (17'2")	1.15 (1.5)	1.05 (1.375)
446D	DBL	04-06	76 (102)	8939 (19,666)	5142 (16'10")	1.15 (1.5)	1.25 (1.63)



PIPELAYERS

Model	Tractor Product Ident. No. Prefix	Years Built	Engine HP	Approx. Weight kg (lb)	Counter-weight kg (lb)	Max. Lift Capacity 1.2 m (4'0") Overhang kg (lb)	Speed Range km/h (mph)		Ground Clearance mm (in)	Ground Contact m ² (in ²)
							Forward	Reverse		
MD6	9U39C	52-57	93	12 375 (27,820)	1590 (3500)	12 035 (26,530)	2.7–10.6 (1.7–6.6)	3.2–10.0 (2.0–6.2)	321 (13)	1.77 (2744)
561B	62A	59-66	90	14 560 (32,100)	2270 (5000)	17 500 (38,800)	2.7–10.6 (1.7–6.6)	1.8–9.9 (2.0–6.2)	267 (11)	2.02 (3130)
561B	62A	66-67	93	14 350 (31,637)	2270 (5000)	17 600 (38,800)	2.7–10.9 (1.7–6.8)	3.4–10.3 (2.1–6.4)	267 (11)	2.02 (3130)
561C	85H	66-67	93	14 700 (32,500)	2450 (5400)	18 000 (40,000)	2.7–11.1 (1.7–6.9)	3.4–10.1 (2.1–6.3)	395 (16)	2.02 (3130)
561C	92J	67-77	105	14 700 (32,500)	2450 (5400)	18 100 (40,000)	2.7–11.1 (1.7–6.9)	3.4–10.1 (2.1–6.3)	395 (16)	2.02 (3130)
561D	54X	78-89	105	15 800 (35,000)	2990 (6600)	18 100 (40,000)	3.5–10.1 (2.2–6.3)	4.2–12.2 (2.6–7.6)	395 (16)	2.02 (3130)
561H	6NL	93-97	105	15 700 (34,600)	2128 (4690)	18 100 (40,000)	3.4–10.2 (2.1–6.4)	4.1–12.4 (2.6–7.7)	363 (14.3)	2.67 (4120)
561M		01	110	16 240 (35,800)	3260 (7200)	18 100 (40,000)	3.3–9.9 (2.0–6.2)	4.0–12.1 (2.5–7.5)	438 (17.2)	2.67 (4120)
561M CB* (US)	1KW	97-02	110	16 240 (35,800)						
561N	CPH	03-08	123	16 851 (37,150)	3270 (7210)	18 145 (40,000)	3.1–9.1 (1.9–5.6)	3.8–11.3 (2.3–6.9)	422 (16.6)	2.93 (4542)
561N	TAD	03-08	123	16 851 (37,150)	3270 (7210)	18 145 (40,000)	3.1–9.1 (1.9–5.6)	3.8–11.3 (2.3–6.9)	422 (16.6)	2.93 (4542)
571E PS	64A	61-67	160	22 680 (50,000)	2360 (5200)	7 490 (60,600)	3.7–10.3 (2.3–6.4)	4.3–12.1 (2.7–7.5)	400 (16)	3.04 (4710)
571E PS	64A	66-72	180	23 100 (51,000)	2360 (5200)	27 500 (60,600)	3.7–10.1 (2.3–6.3)	4.3–11.9 (2.7–7.4)	400 (16)	3.04 (4710)
571F	95N	72-74	180	22 800 (50,300)	4350 (9600)	27 500 (60,600)	3.5–9.7 (2.2–6.0)	4.2–11.4 (2.6–7.1)	400 (16)	3.04 (4710)
571G	16W	75-81	200	23 040 (50,800)	4350 (9600)	27 500 (60,600)	3.7–10.0 (2.3–6.2)	4.5–11.9 (2.8–7.9)	399 (15.7)	3.04 (4710)
	52D(JPN)	87-96	200	(50,800)	(9600)	(60,600)	(2.3–6.2)	(2.8–7.9)	(15.7)	(4710)
MD7	17A	51-57	140	16 200 (35,815)	3400 (7500)	24 585 (54,200)	2.4–9.5 (1.5–5.9)	2.9–8.7 (1.8–5.4)	394 (16)	3.12 (4840)

*Gauge 2.0 m (6'7"), Width 3.19 m (10'5"), Length 3.73 m (12'3"), Height 3.12 m (10'3"), PS Transmission.

Forward Speed: 1st gear 3.27 km/h (2.03 mph)

2nd gear 5.81 km/h (3.61 mph)

3rd gear 9.93 km/h (6.17 mph)

Pipelayers (cont'd)

Model	Tractor Product Ident. No. Prefix	Years Built	Engine HP	Approx. Weight kg (lb)	Counterweight kg (lb)	Max. Lift Capacity 1.2 m (4'0") Overhang kg (lb)	Speed Range km/h (mph)		Ground Clearance mm (in)	Ground Contact m ² (in ²)
							Forward	Reverse		
572C	21A	57-61	128	26 200 (57,820)	4720 (10,405)	39 000 (86,000)	3.2–7.7 (2.0–4.8)	3.9–6.1 (2.4–3.8)	483 (19)	3.30 (5109)
572D	21A	59	140	26 500 (58,520)	4940 (10,900)	39 000 (86,000)	4.2–9.7 (2.6–6.0)	4.8–7.7 (3.0–4.8)	483 (19)	3.30 (5109)
572E PS	65A	61-69	180	28 000 (62,000)	6000 (13,000)	40 800 (90,000)	3.7–10.1 (2.3–6.3)	4.3–11.9 (2.7–7.4)	480 (19)	3.45 (5345)
572F PS	96N	70-74	180	27 600 (61,000)	6440 (14,200)	40 800 (90,000)	3.5–9.7 (2.2–6.0)	4.2–11.4 (2.6–7.1)	480 (19)	3.45 (5345)
572G	40U	75-86	200	27 800 (61,300)	6400 (14,200)	40 800 (90,000)	3.7–10.0 (2.3–6.2)	4.5–11.9 (2.8–7.4)	480 (19)	3.45 (5345)
572G	8PC	84-89	200	27 800 (61,300)	6400 (14,200)	40 800 (90,000)	3.7–10.0 (2.3–6.2)	4.5–11.9 (2.8–7.4)	480 (19)	3.45 (5345)
572R	2HZ	98-04	230	30 110 (66,250)	5055 (11,150)	40 825 (90,000)	3.5–11.1 (2.3–6.9)	4.8–14.2 (3.0–8.8)	414 (16.3)	4.19 (6500)
578	8HB	89-97	300	46 580 (102,690)	11 777 (25,963)	70 307 (155,000)	3.8–10.8 (2.35–6.7)	4.7–13.8 (2.9–8.6)	452 (17.8)	5.17 (8020)
583C	16A	55-58	190	35 440 (78,132)	8470 (18,676)	58 970 (130,000)	3.9–8.7 (2.4–5.4)	3.9–8.7 (2.4–5.4)	533 (21)	4.24 (6580)
583HTC	38A	59-60	235	38 000 (83,840)	9030 (19,900)	62 140 (137,000)	4.5–10.3 (2.8–6.4)	4.5–10.3 (2.8–6.4)	537 (22)	4.66 (7220)
583H PS	61A	60-74	191	35 600 (78,500)	8470 (18,676)	58 970 (130,000)	3.9–8.7 (2.4–5.4)	3.9–8.7 (2.4–5.4)	533 (21)	4.55 (7050)
583H PS	61A	60-67	225	38 200 (84,270)	9000 (19,900)	62 140 (137,000)	4.1–11.1 (2.5–6.9)	4.6–12.8 (8.9–8.0)	537 (22)	4.66 (7220)
583H PS	61A	61	235	38 900 (85,720)	10 400 (22,880)	62 140 (137,000)	3.9–10.1 (2.4–6.3)	4.8–12.6 (3.0–7.8)	537 (22)	4.66 (7220)
583H	61A	74	270	40 600 (89,500)	10 300 (22,700)	63 500 (140,000)	3.9–10.5 (2.4–6.5)	4.8–13.0 (3.0–8.1)	533 (21)	4.65 (7220)
583K	78V	74-89	300	40 960 (90,300)	7840 (17,290)	63 500 (140,000)	4.0–10.9 (2.5–6.8)	5.0–13.5 (3.1–8.4)	530 (21)	4.65 (7220)
583R	2XS	98-05	228 kW (305)	44 748 (98,650)	9036 (19,920)	63 504 (140,000)	3.5–10.8 (2.3–6.8)	4.7–3.8 (2.9–8.6)	537 (21.1)	5.10 (7896)
583T	CMX	06-11	231 kW (310)	45 359 (100,000)	9036 (19,920)	63 504 (140,000)	3.5-10.8 (2.3-6.8)	4.7-13.8 (2.9-8.6)	470 (18.5)	5.10 (7896)
587R	BXL	06-11	273 kW (366)	53 070 (117,000)	12 900 (28,440)	91 625 (202,000)	3.2-10.0 (2.0-6.2)	4.3-12.9 (2.7-8.0)	457 (18)	6.2 (9613)
587T	FAT	06-11	262 kW (351)	53 442 (117,820)	12 900 (28,440)	91 625 (202,000)	3.2-9.7 (2.0-6.0)	4.3-12.6 (2.7-7.8)	457 (18)	6.2 (9613)
589	31Z	82-06	313 kW (420)	65 366 (151,212)	11 854 (26,134)	104 330 (230,000)	3.5–10.9 (2.2–6.8)	4.3–13.7 (2.7–8.5)	625 (24.6)	6.96 (12,148)
594	62H	74	385	55 400 (122,000)	12 600 (27,800)	90 700 (200,000)	3.9–10.5 (2.4–6.5)	4.8–12.7 (3.0–7.9)	640 (25)	5.72 (8865)
594H	96V	74-82	410	56 065 (123,600)	12 555 (27,680)	90 700 (200,000)	4.0–10.8 (2.5–6.7)	5.0–13.2 (3.1–8.2)	630 (25)	6.48 (10,050)



WHEEL TRACTOR-SCRAPERS

Model	Product Ident. No. Prefix	Years Built	Horse-power Max/ Rated	Capacity Struck/ Heaped m ³ (yd ³)	Approx. Shipping Weight kg (lb)	Dimensions m (ft)				Tire Size (Standard) & ply rating Tractor & Scraper	Turning Circle m (ft)
						Length	Width	Height	Width of Tread		
DW10 Tractor	1N	41-46	100/*	—	6550	4.57	2.24	1.93	1.73	10.0 × 20-12	—
					(14,350)	(15'0")	(7'4")	(6'4")	(5'8")	18.0 × 24-16	—
DW10 Tractor	6V	46-47	100/*	—	6850	4.57	2.24	1.93	1.73	10.0 × 20-12	—
					(15,100)	(15'0")	(7'4")	(6'4")	(5'8")	18.0 × 24-16	—
DW10 Tractor	1V	47-53	115/*	—	7540	4.70	2.34	1.93	1.79	12.0 × 20-14	—
					(16,610)	(15'5")	(7'8")	(6'4")	(5'10")	21.0 × 25-20	—
DW10 & No. 10 Scraper	1V 3C	47-51	115/*	6.7/8.4	15 980	11.23	3.02	2.69	1.88	12.0 × 20-14	7.92
				(8.7/11)	(35,240)	(37'0")	(9'11")	(8'10")	(6'2")	21.0 × 25-20	(26'0")
DW10 & No. 10 Scraper	1V 19C	52-53	115/*	5.3/6.9	15 130	10.72	2.87	2.36	1.80	12.0 × 20-14	11.23
				(7/9)	(33,365)	(35'2")	(9'5")	(7'9")	(5'11")	21.0 × 25-20	(37'0")
									Scraper	16.0 × 21-20	—
DW15 & No. 10 Scraper	45C 19C	54-55	/150	5.3/6.9	15 960	11.10	2.87	2.36	1.80	12.0 × 20-14	10.36
				(7/9)	(35,180)	(36'5")	(9'5")	(7'9")	(5'11")	21.0 × 25-20	(34'0")
									Scraper	16.0 × 21-20	—
DW15 & No. 15 Scraper	45C 4W	54-55	/150	7.7/9.2	9400	11.84	3.18	2.69	1.93	12.0 × 20-14	11.23
				(10/12)	(20,720)	(38'10")	(10'5")	(8'10")	(6'4")	21.0 × 25-20	(37'0")
DW15 Tractor	45C	54-55	/150	—	9510	5.08	2.39	2.69	1.98	12.0 × 20-14	—
					(20,960)	(16'8")	(7'10")	(8'10")	(6'6")	21.0 × 25-20	—
DW15C & No. 15 Scraper	59C or 70C	55-57	186/*	7.7/9.5	19 220	11.84	3.18	2.69	1.98	12.0 × 12-14	10.36
				(10/12.5)	(42,370)	(38'10")	(10'5")	(8'10")	(6'6")	21.0 × 25-20	(34'0")
DW15E & No. 428 Scraper	75D or 76D	57-59	200/172	10/14	20 280	12.22	3.30	3.05	1.98	12.0 × 20-14	—
				(13/18)	(44,711)	(40'1")	(10'10")	(10'0")	(6'6")	26.5 × 25-20	—
DW15F & No. 428 Scraper	75D or 76D	58-59	200/172	10/14	20 280	12.22	3.30	3.05	1.98	12.0 × 20-14	—
				(13/18)	(44,711)	(40'1")	(10'10")	(10'0")	(6'6")	26.5 × 25-20	—
DW20 & No. 20 Scraper	21C 11C	51-55	225/*	14/7.6	12 750	13.23	3.53	3.10	2.29	24.0 × 29-4	11.23
				(18/23)	(28,100)	(43'5")	(11'7")	(10'2")	(7'6")	—	(37'0")
DW20 Tractor (For W20 Wagon)	6W	51-55	225/*	—	11 620	5.39	2.79	2.41	2.18	14.0 × 24-16	—
					(25,610)	(17'8")	(9'2")	(7'11")	(7'2")	24.0 × 29-24	—
DW20E & No. 456 Scraper	57C 67C	55-57	300/*	14/19	26 040	13.36	3.58	3.45	2.24	14.0 × 24-16	11.58
				(18/25)	(57,400)	(43'10")	(11'9")	(11'4")	(7'4")	29.5 × 29-22	(38'0")
DW20F & No. 456 Scraper	87E 88E	58-60	320/*	14/19	26 870	13.36	3.58	3.45	2.24	14.0 × 24-16	11.58
				(18/25)	(59,240)	(43'10")	(11'9")	(11'4")	(7'4")	29.5 × 29-22	(38'0")
DW20G & No. 456 Scraper	87E 88E	58-60	345/*	15/21	27 200	13.36	3.58	3.45	2.24	14.0 × 24-16	11.58
				(19.5/27)	(59,960)	(43'10")	(11'9")	(11'4")	(7'4")	29.5 × 29-28	(38'0")
DW20G & No. 482 Scraper	87E 88E	58-60	345/*	18.5/26	31 070	14.05	3.91	3.81	2.39	14.0 × 24-16	11.58
				(24/34)	(68,500)	(46'1")	(12'10")	(12'6")	(7'10")	29.5 × 29-28	(38'0")

*Maximum HP only available.

Wheel Tractor-Scrapers (cont'd)

Model	Product Ident. No. Prefix	Years Built	Horse-power Max/ Rated	Capacity Struck/ Heaped m ³ (yd ³)	Approx. Shipping Weight kg (lb)	Dimensions m (ft)				Tire Size (Standard) & ply rating Tractor & Scraper	Turning Circle m (ft)
						Length	Width	Height	Width of Tread		
DW21 & No. 21 Scraper	8W	51-55	225/*	11.5/15 (15/20)	24 790 (54,650)	12.37 (40'7")	3.53 (11'7")	3.28 (10'9")	2.13 (7'0")	24.0 × 29-24	10.67 (35'0")
DW21C & No. 470 Scraper	58C	55-58	300/*	14/19 (18/25)	26 610 (58,670)	12.67 (41'7")	3.58 (11'9")	3.35 (11'0")	2.24 (7'4")	29.5 × 29-22	11.00 (36'0")
DW21D & No. 470 Scraper	69C	58-58	320/*	14/19 (18/25)	26 310 (58,010)	12.78 (41'11")	3.58 (11'9")	3.35 (11'0")	2.24 (7'4")	29.5 × 29-22	11.00 (36'0")
DW21G & No. 470 Scraper	85E	58-60	345/*	14.9/20.6 (19.5/27)	27 210 (59,980)	12.78 (41'11")	3.58 (11'9")	3.48 (11'5")	2.24 (7'4")	29.5 × 29-28	11.00 (36'0")
611	6SZ	99-03	265	11 (15)	23 900 (52,640)	12.02 (39'5")	3.27 (10'9")	3.24 (10'8")	2.06 (6'9")	29.5R25	10.2 (33'5")
613A	71M	69-76	/150	8.4 (11)	13 334 (29,395)	9.67 (31'9")	2.44 (8'0")	2.85 (9'4.5")	1.89 (6'2.5")	18.0 × 25-12	9.04 (29'8")
613B	38W	76-84	/150	8.4 (11)	14 155 (31,210)	9.78 (32'1")	2.44 (8'0")	2.85 (9'4.5")	1.89 (6'2.5")	18.0 × 25-12	8.94 (29'4")
613C		84-93	175	8.4 (11)	14 670 (32,340)	10.0 (32'9")	2.44 (8'0")	3.06 (10'0")	1.89 (6'2.5")	18.00-25, 16 PR (E-2)	8.9 (29'4")
613C Series II	8LJ	93-08	175	6.8/8.4 (8.9/11)	15 264 (33,650)	10.14 (33'3")	2.44 (8'0")	3.01 (9'10")	1.80 (5'11")	23.5R25★	9.0 (29'6")
613G	ESB	08-10	181	6.8/8.4 (8.9/11)	16 887 (37,229)	10.41 (34'2")	2.43 (8'0")	3.01 (9'11")	1.80 (5'11")	23.5R25★	9.0 (29'6")
615	46Z	81-87	/250	12.23 (16)	23 400 (51,590)	11.6 (38'1")	3.048 (10'0")	3.590 (11'8")	2.21 (7'3")	26.5-25, 26 PR (E-2)	9.63 (31'7")
615C		87-93	265	12.23 (16)	23 860 (52,600)	11.6 (38'1")	3.048 (10'0")	3.59 (11'9")	2.21 (7'3")	26.5-25, 26 PR (E-2)	9.63 (31'7")
615C Series II	9XG	93-08	265	11/13 (14/17)	25 605 (56,450)	11.6 (38'1")	3.05 (10'0")	3.5 (11'0")	2.1 (6'9")	29.5R25★	10.8 (35'6")
619B DD	89E	59-60	/225							Turbocharged, Electric start	
619C PS	90E									Turbocharged, Gas start	
619**	61F	60-66	280/250	10.8/14 (14/18)	21 550 (47,500)	11.05 (36'3")	3.30 (10'11")	3.76 (12'2")	2.00 (6'7")	26.5 × 29-22	9.14 (30'0")
	62F	64-65	/250	15.3/12.6 (20/16.5)	27 400 (60,390)	11.89 (40'0")	3.60 (11'10")	3.45 (11'4")	2.30 (7'7")	26.5 × 29-26	10.20 (33'6")
621	43H	65-72	/300	10.7/15.3 (14/20)	28 400 (62,600)	12.00 (39'5")	3.60 (11'10")	3.45 (11'4")	2.19 (7'3")	29.5 × 29-22	11.50 (37'8")
621	23H	65-74	/300	10.7/15.3 (14/20)	24 900 (55,000)	11.60 (38'1")	3.50 (11'7")	3.40 (11'2")	2.10 (6'10")	29.5 × 29-22	13.00 (42'6")
621B	45P	73-86	/330	10.7/15.3 (14/20)	30 205 (66,590)	12.7 (41'7")	3.45 (11'4")	3.63 (11'11")	2.21 (7'3")	29.5-29, 28 PR (E-3)	11.10 (36'6")
621E	6AB	86-93	/330	10.7/15.3 (14/20)	30 480 (67,195)	12.93 (42'5")	3.47 (11'4")	3.71 (12'2")	2.21 (7'3")	33.25-29, 26 PR (E-3)	10.9 (35'8")

*Maximum HP only available.

**Johnson Manufacturing Company built the J619 Elevating Scraper for Caterpillar in 1964.

Wheel Tractor-Scrapers (cont'd)

Model	Product Ident. No. Prefix	Years Built	Horse-power Max/ Rated	Capacity Struck/ Heaped m ³ (yd ³)	Approx. Shipping Weight kg (lb)	Dimensions m (ft)				Tire Size (Standard) & ply rating Tractor & Scraper	Turning Circle m (ft)
						Length	Width	Height	Width of Tread		
621F	4SK	93-00	330	10.7/15.3 (14/20)	32 090 (70,740)	12.93 (42'5")	3.47 (11'4")	3.71 (12'2")	2.21 (7'3")	33.25-29 ★★ (E-2/E-3)	10.2 (33'5")
621G	ALP	00-03	330/365	10.7/15.3 (14/20)	32 250 (71,090)	12.93 (42'5")	3.47 (11'4")	3.71 (12'2")	2.20 (7'3")	33.25R29	11.7 (38'5")
621G	CEN	03-05	330/365	12/17 (15.7/22)	32 563 (71,790)	12.93 (42'5")	3.47 (11'4")	3.71 (12'2")	2.20 (7'3")	33.25R29	11.7 (38'5")
621G	DBB	05-10	330/365	12/17 (15.7/22)	33 995 (74,946)	12.88 (42'3")	3.58 (11'9")	3.71 (12'3")	2.23 (7'4")	33.25R29 ★★ (E-3)	11.7 (38'5")
621H	DBK EAZ	10-13	407	13/18.4 (17.1/24)	36 185 (79,787)	14.02 (45'10")	3.57 (11'7")	4.03 (13'2")	2.29 (7'5")	33.25R29 ★★ (E-3)	11.8 (38'7")
623	52U	72-74	/300	16.8 (22)	29 900 (66,000)	11.90 (39'0")	3.50 (11'7")	3.70 (12'1")	2.20 (7'3")	29.5 × 29-28	13.70 (44'11")
623B	46P	73-86	/330	16.8 (22)	32 546 (71,750)	12.5 (41'1")	3.55 (11'8")	3.81 (12'6")	2.18 (7'2")	29.5-29, 28 PR (E-2)	8.90 (29'4")
623E	6CB	86-89	/330	16.8 (22)	33 317 (73,450)	12.61 (41'4")	3.55 (11'8")	3.81 (12'6")	2.21 (7'3")	29.5-29, 34 PR (E-2)	10.9 (35'9")
623E	6YF	89-93	/365	13.8/17.6 (18/23)	35 290 (77,800)	12.61 (41'4")	3.55 (11'8")	3.94 (12'11")	2.18 (7'2")	29.5R25	10.9 (35'8")
623F	6BK	93-98	365	13.8/17.6 (18/23)	35 305 (77,830)	12.61 (41'4")	3.55 (11'8")	3.94 (12'11")	2.18 (7'2")	29.5-29, 34 PR (E-2)	10.9 (35'8")
623F Series II	5EW	98-00	365	13.8/17.6 (18/23)	37 122 (81,840)	13.28 (43'7")	3.55 (11'8")	3.55 (11'8")	2.21 (7'3")	33.25-R29 ★★ (E-2)	8.6 (28'5")
623G	ARW	00-02	330/365	13.8/17.6 (18/23)	37 120 (81,840)	13.21 (43'4")	3.55 (11'8")	3.68 (12'1")	2.2 (7'3")	33.25R29	10.9 (35'8")
623G	CES	03-05	330/365	13.8/17.6 (18/23)	37 120 (81,840)	13.21 (43'4")	3.55 (11'8")	3.68 (12'1")	2.2 (7'3")	33.25R29	10.9 (35'8")
623G	DBC	05-10	330/365	13.8/17.6 (18/23)	37 510 (82,695)	13.17 (43'2")	3.58 (11'9")	3.71 (12'3")	2.23 (7'4")	33.25R29 ★★ (E-3)	12.0 (39'4")
623H	DBF EJD	10-13	407	14.4/17.6 (18.8/23)	39 937 (88,061)	13.77 (45'2")	3.57 (11'7")	3.77 (12'3")	2.29 (7'5")	33.25R29 ★★ (E-3)	11.8 (38'7")

Wheel Tractor-Scrapers (cont'd)

Model	Product Ident. No. Prefix	Years Built	Horse-power Max/ Rated	Capacity Struck/ Heaped m ³ (yd ³)	Approx. Shipping Weight kg (lb)	Dimensions m (ft)				Tire Size (Standard) & ply rating Tractor & Scraper	Turning Circle m (ft)
						Length	Width	Height	Width of Tread		
627	54K	68-74	T/225	10.7/15.3	29 900	12.00	3.50	3.60	2.20	29.5 × 29-28	13.30
			S/225	(14/20)	(66,000)	(36'9")	(11'7")	(11'8")	(7'3")		(43'9")
627B	14S	73-86	T/225	10.7/15.3	34 610	13.3	3.45	3.63	2.18	29.5-29,	11.10
			S/225	(14/20)	(76,300)	(43'9")	(11'4")	(11'11")	(7'2")	28 PR (E-3)	(36'6")
627E	6EB	86-90	T/225	10.7/15.3	34 670	12.89	3.47	3.71	2.21 (7'3")	33.25-29,	10.90
			S/225	(14/20)	(76,435)	(42'3")	(11'4")	(12'2")	2.18 (7'2")	26 PR (E-3)	(35'9")
627E	7CG	90-93	T/330	10.7/15.3	35 160	12.93	3.47	3.71	2.21	33.25-29,	10.9
			S/225	(14/20)	(77,500)	(42'5")	(11'4")	(12'2")	(7'3")	26 PR (E-3)	(35'8")
627F Series II	1DL	93-00	T/330	10.7/15.3	37 060	12.9	3.47	3.71	2.21	33.25-R29	10.9
			S/225	(14/20)	(81,640)	(42'5")	(11'4")	(12'2")	(7'3")	★★ (E-2/E-3)	(35'9")
627B/PP	15S	73-86	T/225	10.7/15.3	35 660	14.91	3.45	3.63	2.21	29.5-29,	11.1
			S/225	(14/20)	(78,620)	(48'11")	(11'4")	(11'11")	(7'2")	28 PR (E-3)	(36'6")
627E/PP	6GB	86-89	T/225	10.7/15.3	36 130	12.89	3.47	3.71	2.21 (7'3")	33.25-29,	10.90
			S/225	(14/20)	(79,655)	(42'3")	(11'4")	(12'2")	2.18 (7'2")	26 PR (E-3)	(35'9")
627E/PP	7CG	90-93	T/330	10.7/15.3	36 620	15.2	3.47	3.71	2.21	33.25-29,	10.9
			S/225	(14/20)	(80,735)	(49'7")	(11'4")	(12'2")	(7'3")	26 PR (E-3)	(35'8")
627F/PP Series II	1DL	93-00	T/330	10.7/15.3	38 103	15.2	3.47	3.71	2.21	33.25-R29	10.9
			S/225	(14/20)	(84,000)	(49'7")	(11'4")	(12'2")	(7'3")	★★ (E-2/E-3)	(35'9")
627G/PP	AXF	00-02	T/330/365	10.7/15.3	38 140	15.2	3.47	3.71	2.20	33.25R29	11.7
			S/225	(14/20)	(84,075)	(49'7")	(11'4")	(12'2")	(7'3")		(38'5")
627G/PP	CEX	02-05	T/330/365	12/17	39 186	15.2	3.47	3.71	2.20	33.25R29	11.7
			S/225/249	(15.7/22)	(86,390)	(49'7")	(11'4")	(12'2")	(7'3")		(38'5")
627G P/P	DBD	05-10	T/330/365	12/17	39 443	15.2	3.58	3.81	2.23	33.25R29	11.7
			S/239/266	(15.7/22)	(86,957)	(49'7")	(11'9")	(12'6")	(7'4")	★★ (E-3)	(38'5")
									Tractor 2.20 (7'3")		
									Scraper		
627H	DBW LCT	10-13	T/407	13/18.4	26 127	14.02	3.57	4.03	2.29	33.25R29	11.8
			S/290	17.1/24	(90,213)	(45'10")	(11'7")	(13'2")	(7'5")	★★ (E-3)	(38'7")
									Tractor 2.28 (7'4")		
									Scraper		
630A & 482C Scraper	52F	60-62	420/335	21/27	35 830	14.63	3.91	4.01	2.39	16.0 × 25-16	11.89
				(27/35)	(79,000)	(48'0")	(12'10")	(13'2")	(7'10")	29.5 × 35-28	(39'0")
									Scraper	33.5 × 33-26	
630A	52F	60-62	420/335	16/21.4	31 430	13.82	3.58	3.73	2.21	16.0 × 25-16	11.89
				(21/28)	(69,300)	(45'4")	(11'9")	(12'3")	(7'3")	29.5 × 35-28	(39'0")
630B	14G	62-63	420/335	16/23	33 520	14.12	3.81	3.71	2.41	16.0-25, 16	13.36
				(21/30)	(73,900)	(46'4")	(12'6")	(12'2")	(7'11")	29.5-35, 28	(43'10")
630B	14G	63-66	400/360	16/23	33 570	14.30	3.81	3.94	2.41	16.0-25, 16	13.36
				(21/30)	(74,000)	(46'11")	(12'6")	(12'11")	(7'11")	29.5-35, 34	(43'10")
630B	10G	62-69	/400	16/23	35 750	14.35	3.81	3.94	2.40	16.0-25, 16	13.36
				(21/30)	(78,800)	(47'1")	(12'6")	(12'11")	(7'10")	29.5-35, 34	(43'10")

T — Tractor Engines
S — Scraper Engines

Wheel Tractor-Scrapers (cont'd)

Model	Product Ident. No. Prefix	Years Built	Horse-power Max/ Rated	Capacity Struck/ Heaped m ³ (yd ³)	Approx. Shipping Weight kg (lb)	Dimensions m (ft)				Tire Size (Standard) & ply rating Tractor & Scraper	Turning Circle m (ft)
						Length	Width	Height	Width of Tread		
631A	51F	60-62	420/335	16/21.4 (21/28)	30 250 (66,700)	12.88 (42'3")	3.58 (11'9")	3.56 (11'8")	2.21 (7'3")	29.5-35, 28	11.00 (36'0")
631B	13G	62-62	420/335	16/23 (21/30)	31 620 (69,700)	13.05 (42'10")	3.81 (12'6")	3.45 (11'5")	2.39 (7'10")	29.5-35, 28	11.31 (37'5")
631B	13G	62-66	420/360	16/23 (21/30)	31 840 (70,200)	13.29 (43'7")	3.81 (12'6")	3.63 (11'11")	2.41 (7'11")	29.5-35, 34	11.31 (37'5")
631C	67M	69-75	/415	16/23 (21/30)	36 350 (80,150)	13.54 (44'5")	3.45 (11'4")	3.91 (12'10")	2.39 (7'10")	29.5-35, 34	11.45 (37'7")
631D	24W	75-85	473/450	16/23.7 (21/31)	42 370 (93,410)	14.25 (46'9")	3.96 (13'0")	4.17 (13'8")	2.46 (8'1")	33.25-35, 38 PR (E-3)	12.2 (40'1")
631E	1AB	85-91	473/450	16.1/23.7 (21/31)	43 365 (95,600)	14.28 (46'10")	3.94 (12'11")	4.29 (14'1")	2.46 (8'1")	37.25-35, 30	12.2 (40'1")
631E Series II	1AB	91-01	473/450	16.1/23.7 (21/31)	44 210 (97,460)	14.56 (47'9")	3.94 (12'11")	4.29 (14'1")	2.46 (8'1")	37.25R35	12.2 (40'1")
631G	AWK	00-02	450/485	16.1/23.7 (21/31)	46 475 (102,460)	14.56 (47'9")	3.94 (12'11")	4.29 (14'1")	2.46 (8'1")	37.25R35	12.2 (40'1")
631G	CLR	03-05	450/485	18.3/26 (24/34)	46 475 (102,460)	14.56 (47'9")	3.94 (12'11")	4.29 (14'1")	2.46 (8'1")	37.25R35	12.2 (40'1")
631G	DFA	05-16	462/500	18.3/26 (24/34)	47 628 (105,002)	14.71 (48'3")	3.94 (12'11")	4.29 (14'1")	2.46 (8'1")	37.25R35	12.2 (40'1")
632	14G	62-63	420/335	21.4/29 (28/38)	37 650 (83,000)	15.21 (49'11")	4.04 (13'3")	4.00 (13'1")	2.44 (8'0")	16.0-25, 16 29.5-35, 34	13.36 (43'10")
632	14G	63-66	420/360	21.4/29 (28/38)	39 420 (86,910)	15.30 (50'2")	4.04 (13'3")	4.00 (13'1")	2.44 (8'0")	16.0-25, 16 29.5-35, 34	13.36 (43'10")
633C	66M	69-75	/415	24.5 (32)	41 750 (92,050)	13.36 (43'10")	3.45 (11'4")	3.96 (13'0")	2.39 (7'10")	33.2-35, 32	11.78 (38'8")
633D	25W	75-85	450	17.7/23 (23/34)	47 570 (104,870)	14.40 (47'3")	3.96 (13'0")	4.24 (13'11")	2.46 (8'1")	33.25-35, 38 PR (E-3)	12.4 (40'7")
633E	1AB	92-96	475	17.7/23 (23/34)	50 800 (112,000)	14.40 (47'3")	3.96 (13'0")	4.24 (13'11")	2.46 (8'1")	37.25R35	13.15 (43'2")
633E Series II	2PS	96-00	490	17.7/23 (23/34)	51 100 (112,670)	14.8 (48'7")	3.96 (13'0")	4.24 (13'11")	2.46 (8'1")	37.25R35	13.15 (43'2")

Wheel Tractor-Scrapers (cont'd)

Model	Product Ident. No. Prefix	Years Built	Horse-power Max/ Rated	Capacity Struck/ Heaped m ³ (yd ³)	Approx. Shipping Weight kg (lb)	Dimensions m (ft)				Tire Size (Standard) & ply rating Tractor & Scraper	Turning Circle m (ft)
						Length	Width	Height	Width of Tread		
637	65M	70-75	T/415	16/23	41 300	13.65	3.45	3.93	2.39	33.25-35, 32	11.68
			S/225	(21/30)	(91,050)	(44'9.5")	(11'4")	(12'11")	(7'10")		(38'4")
637/PP	79P	70-75	T/415	16/23	43 700	15.82	3.45	3.93	2.39	33.25-35, 32	11.68
			S/225	(21/30)	(96,350)	(51'11")	(11'4")	(12'11")	(7'10")		(38'4")
637D	26W	75-85	T/450	16/23	46 987	14.8	3.96	4.17	2.46	33.25-35,	12.2
			S/250	(21/31)	(103,590)	(48'8")	(13'0")	(13'8")	(8'1")	38 PR (E-3)	(40'1")
637D/PP	27W	75-85	T/450	16/23	48 531	14.8	3.96	4.17	2.46	33.25-35,	12.2
			S/250	(21/31)	(106,990)	(48'8")	(13'0")	(13'8")	(8'1")	38 PR (E-3)	(40'1")
637E	1FB	85-91	T/450	16/23	49 940	14.28	3.94	4.29	2.46	37.25-35, 30	12.2
			S/250	(21/31)	(110,100)	(46'10")	(12'11")	(14'1")	(8'1")		(40'1")
637E Series II	1FB	91-01	T/450	16/23	50 990	14.56	3.94	4.29	2.46	37.25R35	12.2
			S/250	(21/31)	(112,320)	(47'9")	(12'11")	(14'1")	(8'1")		(40'1")
637E/PP	1FB	85-91	T/450	16/23	51 485	15.88	3.94	4.29	2.46	37.25-35, 30	12.2
			S/250	(21/31)	(113,500)	(52'1")	(12'11")	(14'1")	(8'1")		(40'1")
637E Series II/PP	1FB	91-01	T/450	16/23	52 385	16.49	3.94	4.29	2.46	37.25R35	12.2
			S/250	(21/31)	(115,490)	(54'1")	(12'11")	(14'1")	(8'1")		(40'1")
637G/PP	AXT	00-02	T/450/485	16.1/23.7	53 590	16.49	3.94	4.29	2.46	37.25R35	12.2
			S/249	(21/31)	(118,150)	(54'1")	(12'11")	(14'1")	(8'1")		(40'1")
637G/PP	CEH	02-05	T/450/485	18.3/26	53 562	16.49	3.94	4.29	2.46	37.25R35	12.2
			S/249/274	(24/34)	(118,084)	(54'1")	(12'11")	(14'1")	(8'1")		(40'1")
637G/PP	DFJ	06-16	T/462/500	18.3/26	54 005	16.64	3.94	4.29	2.46	37.25R35	12.2
			S/266/283	(24/34)	(119,060)	(54'7")	(12'11")	(14'1")	(8'1")		(40'1")
639D	99X	79-84	T/450	26	55 030	14.53	3.96	4.06	2.46	37.25-35, 42	12.4
			S/250	(34)	(121,318)	(47'8")	(13'0")	(13'4")	(8'1")	37.25-35, 42	(40'7")
641	64F	62-65	560/450	21.4/29	43 200	14.73	4.04	4.00	2.44	33.5-39, 38	12.68
				(28/38)	(95,300)	(48'4")	(13'3")	(13'1")	(8'0")		(41'7")
641B	65K	69-81	/550	21.4/29	53 070	14.96	4.04	4.24	2.55	37.5-39, 36	13.00
				(28/38)	(117,000)	(49'1")	(13'3")	(13'11")	(8'4")		(42'9")
650	63F	62-64	560/450	24.5/33.6	45 130	16.31	4.24	4.01	2.54	18.0-25, 20	13.87
				(32/44)	(99,500)	(53'6")	(13'11")	(13'2")	(8'4")S	33.5-39, 32	(45'6")
										37.5-39, 36	
650B	22G	62-72	/550	24.5/33.6	46 100	17.00	3.80	4.30	2.65	18.0-25, 20	14.00
				(32/44)	(101,700)	(55'10")	(12'6")	(14'1")	(8'9")S	37.5-39, 28	(46'0")
										37.5-30, 36	

T — Tractor Engines
S — Scraper Engines

Wheel Tractor-Scrapers (cont'd)

Model	Product Ident. No. Prefix	Years Built	Horsepower Max/ Rated	Capacity Struck/ Heaped m ³ (yd ³)	Approx. Shipping Weight kg (lb)	Dimensions m (ft)				Tire Size (Standard) & ply rating Tractor & Scraper	Turning Circle m (ft)
						Length	Width	Height	Width of Tread		
651	33G	62-68	560/450	24.5/33.6 (32/44)	43 730 (96,400)	14.93 (49'0")	4.24 (13'11")	4.01 (13'2")	2.54 (8'4")	37.5-39, 36	13.29 (43'7")
651B	67K	69-84	/550	24.5/33.6 (32/44)	56 340 (124,200)	15.34 (51'4")	4.32 (14'2")	4.29 (14'1")	2.72 (8'11")S	37.5-39, 36	13.5 (44'2")
651E	89Z	82-96	550	24.5/33.6 (32/44)	59 420 (131,000)	16.13 (52'11")	4.37 (14'4")	4.7 (15'5")	2.64 (8'8")	37.5R39	14.5 (47'7")
651E	4YR	96-06	550/605	24.5/33.6 (32/44)	61 126 (134,760)	16.18 (53'1")	4.37 (14'4")	4.7 (15'5")	2.64 (8'8")	40.5/75R39	15.1 (49'8")
657	31G	62-68	T/450 S/335	24.5/33.6 (32/44)	56 550 (124,700)	15.39 (50'6")	4.24 (13'11")	4.09 (13'5")	2.62 (8'7")	37.5-39, 44	13.29 (43'7")
657	46M	68-69	T/500 S/400	24.5/33.6 (32/44)	56 820 (125,155)	15.39 (50'6")	4.24 (13'11")	4.09 (13'5")	2.67 (8'8")	37.5-39, 44	14.57 (47'10")
657B	68K	69-84	T/550 S/400	24.5/33.6 (32/44)	63 100 (139,100)	15.7 (51'8")	4.32 (14'2")	4.21 (13'10")	2.67 (8'9")S	37.5-39, 44	13.7 (45'1")
657E	90Z	82-95	T/550 S/400	24.5/33.6 (32/44)	68 720 (151,500)	17 (55'10")	4.37 (14'4")	4.7 (15'5")	2.64 (8'8")	37.5R39	14.5 (47'7")
657E	6TR	96-06	T/550/605 S/400/440	24.5/33.6 (32/44)	69 078 (152,290)	16.2 (53'1")	4.37 (14'4")	4.7 (15'5")	2.64 (8'8")	40.5/75R39	15.1 (49'8")
657E/PP	91Z	82-95	T/550 S/400	24.5/33.6 (32/44)	72 120 (159,000)	18.01 (59'1")	4.37 (14'4")	4.7 (15'5")	2.64 (8'8")	37.5R39	14.5 (47'7")
657E/PP	5YR	96-06	T/550/605 S/400/440	24.5/33.6 (32/44)	72 857 (160,623)	18.01 (59'1")	4.37 (14'4")	4.7 (15'5")	2.64 (8'8")	40.5/75R39	15.1 (49'8")
660	90F	62-64	560/450	30.6/41.3 (40/54)	49 130 (108,300)	17.04 (55'11")	4.24 (13'11")	4.37 (14'4")	2.59 (8'6")	18.0 × 25-20 37.5 × 39-28 37.5 × 51-36	13.87 (45'6")
660B	58K	70-78	/550	30.6/41.3 (40/54)	59 875 (132,000)	17.27 (56'8")	3.81 (12'2")	4.37 (14'4")	Scrapper	18.0 × 25-20 37.5 × 39-28	14.00 (46'0")
666	77F	63-69	T/450 S/335	30.6/41.3 (40/54)	56 700 (125,000)	17.04 (55'11")	4.24 (13'11")	4.37 (14'4")	2.59 (8'6")	18.0 × 25-20 37.5 × 39-28	13.87 (45'6")
666	64H	67-69	T/500 S/400	30.6/41.3 (40/54)	58 800 (129,645)	17.27 (56'8")	4.24 (13'11")	4.37 (14'4")	2.59 (8'6")	18.0 × 25-20 37.5 × 39-28	13.87 (45'6")
666B	66K	69-78	T/550 S/400	30.6/41.3 (40/54)	67 630 (149,500)	17.27 (56'8")	4.31 (14'4")	4.37 (14'4")	2.59 (8'9")	18.0 × 25-20 37.5 × 51-51	14.00 (46'0")

T — Tractor Engines
S — Scraper Engines



TRACTOR-TOWED SCRAPERS

Model	Product Ident. No. Prefix	Years Built	Capacity Struck/Heaped m ³ (yd ³)	Weight kg (lb)	Width m (ft)	Length m (ft)	Height m (ft)	Width of Cut m (ft)
40	1W	49-59	2.8/3.4 (3.6/4.5)	3348 (7380)	2.27 (7'6")	6.40 (21'0")	1.68 (5'6")	1.82 (6'0")
60	1D	47-53	4.6/6.1 (6.0/8.0)	5579 (12,300)	2.65 (8'9")	8.43 (27'8")	2.36 (7'9")	2.13 (7'0")
60	2W	52-72	5.4/7.0 (7.0/9.0)	6100 (13,500)	2.85 (9'5")	8.52 (28'3")	2.36 (7'9")	2.40 (7'11")
70	8C	46-53	6.7/8.4 (8.7/11.0)	8527 (18,800)	3.02 (10'0")	9.50 (31'2")	2.56 (8'5")	2.43 (8'0")
70	3W	51-57	7.8/9.9 (10.2/13.0)	9140 (20,150)	3.16 (10'5")	9.53 (31'4")	2.61 (8'7")	2.59 (8'6")
80	2D	46-52	10.3/13.8 (13.5/18.0)	11 793 (26,000)	3.38 (11'2")	10.82 (35'6")	2.92 (9'7")	2.74 (9'0")
80	5W	50-56	11.5/15.3 (15.0/20.0)	13 533 (29,836)	3.50 (11'6")	10.92 (35'0")	3.09 (10'2")	2.89 (9'6")
90	9V	51-55	16.2/20.6 (21.2/27.0)	17 208 (37,937)	3.65 (12'0")	12.19 (40'0")	3.20 (10'6")	3.04 (10'0")
435C	45D	56-61	9.9/13.8 (13.0/18.0)	10 659 (23,500)	3.28 (10'10")	10.16 (33'4")	3.01 (9'11")	2.84 (9'4")
435D	45D	59-61	11.5/14.5 (15.0/19.0)	11 521 (25,400)	3.29 (10'10")	10.16 (33'4")	3.01 (9'11")	2.84 (9'4")
435E	85F	61-72	9.2/13.0 (12.0/17.0)	10 400 (22,900)	3.29 (10'10")	10.06 (33'1")	3.07 (10'1")	2.84 (9'4")
435F	45D	62-72	10.7/13.8 (14.0/18.0)	11 300 (24,900)	3.29 (10'10")	10.06 (33'1")	3.02 (9'11")	2.84 (9'4")
435G	27G	63-73	9.2/13.0 (12.0/17.0)	10 400 (22,900)	3.27 (10'9")	10.08 (33'1")	2.97 (9'9")	2.84 (9'4")
463	62C	55-60	13.8/29.1 (18.0/25.0)	14 061 (31,000)	3.58 (11'9")	11.58 (38'0")	3.39 (11'2")	3.15 (10'4")
463C	62C	59-60	16.8/21.4 (22.0/28.0)	15 785 (34,800)	3.58 (11'9")	11.58 (38'0")	3.39 (11'2")	3.15 (10'4")
463E	86F	60-71	13.8/20.0 (18.0/26.0)	15 600 (34,400)	3.58 (11'9")	11.65 (38'3")	3.28 (10'10")	3.15 (10'4")
463F	62C	63-71	16.0/21.4 (21.0/28.0)	15 700 (34,600)	3.58 (11'9")	11.65 (38'3")	3.28 (10'10")	3.15 (10'4")
463G	28G	63-71	13.8/20.0 (18.0/26.0)	13 200 (29,200)	3.58 (11'9")	11.52 (37'10")	3.14 (10'4")	3.15 (10'4")
491	98C	56-64	20.6/26.0 (27.0/34.0)	16 964 (37,400)	3.65 (12'0")	12.13 (39'10")	3.96 (13'0")	3.16 (10'5")
491B	9A	61-63	20.6/26.8 (27.0/35.0)	20 902 (46,060)	3.91 (12'10")	12.49 (41'0")	3.96 (13'0")	3.30 (10'10")
491C	47E	63-70	20.6/26.8 (27.0/35.0)	21 600 (47,500)	3.91 (12'10")	12.64 (41'6")	3.96 (13'0")	3.30 (10'10")
TS180 Lead	E1J	09-13	11/14.5 (14.4/19)	11 748 (25,900)	3.378 (11.08)	8.915 (29.25)	2.362 (7.75)	3.2 (10.5)
TS180 Trail	E1K	09-13	11/14.5 (14.4/19)	12 748 (25,900)	3.378 (11.08)	8.915 (29.25)	2.362 (7.75)	3.2 (10.5)
TS185 Lead	E1R	09-13	11/14.5 (14.4/19)	11 748 (25,900)	3.988 (13.08)	9.119 (29.92)	2.515 (8.25)	3.785 (12.4)
TS185 Trail	E1S	09-13	11/14.5 (14.4/19)	12 748 (25,900)	3.988 (13.08)	9.119 (29.92)	2.515 (8.25)	3.785 (12.4)
TS220 Lead	E1L	09-13	13/18 (17/23.5)	13 145 (28,980)	3.683 (12.08)	9.677 (31.75)	2.464 (8.08)	3.480 (11.4)
TS220 Trail	E1N	09-13	13/18 (17/23.5)	14 145 (28,980)	3.683 (12.08)	9.677 (31.75)	2.464 (8.08)	3.480 (11.4)
TS225 Lead	E1T	09-13	13/18 (17/23.5)	15 250 (33,620)	3.988 (13.08)	10.287 (33.75)	2.515 (8.25)	3.785 (12.4)
TS225 Trail	E1W	09-13	13/18 (17/23.5)	16 250 (33,620)	3.988 (13.08)	10.287 (33.75)	2.515 (8.25)	3.785 (12.4)



MINING & OFF-HIGHWAY TRUCKS/TRACTORS

Model	Product Ident. No. Prefix	Years Built	Flywheel Kilowatts (Horsepower)	Capacity Metric Tons (U.S. Tons)	Approx. Weight kg (lb)	Dimensions m (ft)						Tire Size
						Width	Length	Height	Loading Height	Dumping Height (55°)	Turning Circle	
768B	79S	71-78	309 (415)	— —	22 000 (48,500)	3.61 (11'10")	6.55 (21'6")	3.48 (11'5")	— —	— —	18.0 (59'1")	18.00 × 33—24 PR
768C	02X	78-95	336 (450)	— —	24 624 (54,285)	4.70 (15'5")	8.00 (26'3")	3.56 (11'8")	— —	— —	18.5 (60'8")	18.00R33 E-4
769	99F	62-67	298 (400)	31.8 (35.0)	25 365 (55,870)	3.63 (11'11")	7.64 (25'1")	4.05 (13'4")	3.07 (10'1")	7.18 (26'7")	16.5 (54'5")	18.00 × 25—32 PR
769B	99F	67-78	309 (415)	32.0 (35.0)	28 000 (61,800)	3.64 (11'11.5")	7.85 (25'9")	3.89 (12'9")	3.15 (10'4")	7.24 (23'9")	18.0 (59'1")	18.00 × 25—32 PR E-3
769C	01X	78-95	336 (450)	36.9 (40.6)	30 675 (67,855)	4.70 (15'5")	8.00 (26'3")	3.85 (12'8")	3.24 (10'7")	7.68 (25'2")	18.5 (60'8")	18.00R33 E-4
769D	5TR, 5SS, BBB	95-06	363 (487)	36.4 (40.0)	33 875 (74,682)	5.07 (16'8")	8.24 (27'0")	4.03 (13'3")	3.14 (10'4")	7.71 (25'4")	17 (55'9")	18.00R33
770	BZZ	07-14	355 (476)	36.5 (40.3)	34 642 (76,372)	4.75 (15'8")	8.74 (28'9")	4.14 (13'7")	3.12 (10'3")	8.28 (27'2")	20.2 (66'3")	18.00R33 (E-4)
771C	3BJ	92-95	336 (450)	40.0 (44.0)	34 170 (75,345)	4.74 (15'7")	8.20 (26'11")	4.00 (13'1")	3.30 (10'10")	7.68 (25'2")	18.5 (60'8")	18.00R33 E-4
771D	6JR, 6YS, BCA	96-06	363 (487)	41 (45)	33 784 (74,482)	5.07 (16'8")	8.40 (27'7")	4.02 (13'2")	3.40 (11'1")	7.74 (25'5")	17 (55'9")	18.00R33
772	RLB	07-14	399 (535)	46.2 (51.0)	35 864 (79,066)	4.75 (15'8")	8.74 (28'9")	4.22 (13'10")	3.50 (11'6")	8.36 (27'5")	21.6 (70'10")	21.00R33 (E-4)
772	80S	71-78	447 (600)	— —	32 100 (70,800)	4.06 (13'4")	7.11 (23'4")	3.68 (12'1")	— —	— —	22.1 (72'6")	24.00 × 35—36 PR
772B	64W	78-95	485 (650)	— —	32 909 (72,550)	4.86 (15'11")	9.12 (29'11")	4.52 (14'10")	— —	— —	23.5 (77'0")	24.00R35 E-4
773	63G	70-78	447 (600)	45.4 (50.0)	37 800 (83,360)	4.06 (13'4")	8.71 (28'7")	4.27 (14'0")	3.61 (11'10")	8.36 (27'5")	22.1 (72'6")	21.00 × 35—32 PR E-3
773B	63W	78-95	485 (650)	54.3 (59.8)	38 321 (84,500)	4.86 (15'11")	9.12 (29'11")	4.31 (14'2")	3.77 (12'5")	8.72 (28'7")	23.5 (77'0")	24.00R35 E-4
773D	7CS, 7ER	96-01	485 (650)	52.9 (58.4)	43 600 (96,000)	5.08 (16'8")	9.21 (29'11")	4.42 (14'6")	3.79 (12'5")	8.82 (28'11")	22.0 (72'2")	24.00R35
773E	BDA (U.S.)	01-06	501 (671)	54.4 (60.0)	45 480 (100,180)	5.08 (16'8")	9.21 (29'11")	4.42 (14'6")	3.79 (12'5")	8.82 (28'11")	22.0 (72'2")	24.00R35
773F	EED, EXD	06-11	524 (703)	54.4 (60.0)	45 069 (99,360)	5.43 (17'10")	10.33 (33'11")	4.44 (14'7")	3.77 (12'5")	9.26 (30'5")	26.1 (85'8")	24.00R35 (E-4)
775B	7XJ	92-95	485 (650)	59.5 (65.5)	42 324 (93,325)	4.91 (16'2")	9.33 (30'7")	4.31 (14'2")	3.86 (12'8")	8.72 (28'8")	23.5 (77'7")	24.00R35 E-4
775D	6KR, 8AS	95-01	517 (693)	63.4 (69.9)	43 200 (95,300)	5.08 (16'8")	9.30 (30'6")	4.42 (14'6")	3.91 (12'10")	8.82 (28'11")	22.0 (72'2")	24.00R35
775E	BEC	01-06	544 (730)	63.5 (70.0)	43 470 (95,810)	5.08 (16'8")	9.21 (29'11")	4.42 (14'6")	3.91 (12'10")	8.82 (28'11")	22.0 (72'2")	24.00R35
775F	DLS, EYG	06-11	552 (740)	63.5 (70.0)	45 620 (100,575)	5.43 (17'10")	10.33 (33'11")	4.44 (14'7")	3.97 (13'0")	9.26 (30'5")	26.1 (85'8")	24.00R35 (E-4)

Mining & Off-Highway Trucks/Tractors (cont'd)

Model	Product Ident. No. Prefix	Years Built	Flywheel Kilowatts (Horse-power)	Capacity Metric Tons (U.S. Tons)	Approx. Weight kg (lb)	Dimensions m (ft)						Tire Size
						Width	Length	Height	Loading Height	Dumping Height (55°)	Turning Circle	
776	14H	75-84	649 (870)	—	49 686 (109,540)	3.51 (11'6")	8.06 (26'5.5")	3.40 (11'2")	—	—	26.8 (88'0")	27.00 × 49—36 PR E-3
776B	6JC	84-92	649 (870)	—	49 896 (110,000)	3.51 (11'6")	8.06 (26'6")	3.40 (11'2")	—	—	25.8 (84'6")	27.00 × 49—36 PR E-3
776C	2TK	92-96	649 (870)	—	49 896 (110,000)	3.51 (11'6")	8.06 (26'5.5")	4.55 (14'11")	—	—	25.8 (84'6")	27.00R49
777	84A	74-84	649 (870)	77.1 (85.0)	58 886 (129,820)	5.463 (17'11")	9.78 (32'1")	4.90 (16'1")	4.14 (13'7")	9.29 (30'6")	26.8 (88'0")	24.00 × 49—42 PR E-3
777B	4YC	84-92	649 (870)	86.2 (95.0)	60 055 (132,422)	5.463 (17'11")	9.79 (32'1")	4.97 (16'4")	4.17 (13'8")	9.42 (30'11")	25.8 (84'6")	24.00 × 49—48 PR E-3
777C	4XJ	92-96	649 (870)	86.2 (95.0)	61 790 (136,227)	5.463 (17'11")	9.79 (32'1")	4.97 (16'4")	4.17 (13'8")	9.42 (30'11")	25.8 (84'6")	27.00R49
777D (Decatur)	2YW, AGC (U.S.)	96-06	699 (938)	90.9 (100.0)	72 575 (160,000)	6.11 (20'0")	9.78 (32'1")	5.15 (16'10")	4.38 (14'4")	10.06 (33'0")	25.3 (83'0")	27.00R49
777F	JRP, JXP	06-11	700 (938)	90.9 (100.0)	72 739 (160,360)	6.49 (21'4")	10.54 (34'7")	5.17 (17'0")	4.38 (14'4")	10.33 (33'11")	28.4 (93'2")	27.00R49 (E4)
784B	5RK	93-98	962 (1290)	—	89 280 (196,825)	6.74 (22'2")	9.34 (30'8")	5.47 (17'1")	—	—	33.5 (109'10")	36.00R51 E-3
784C	2PZ	98-09	1005 (1348)	—	88 746 (195,651)	7.00 (23'0")	9.34 (30'8")	5.47 (17'1")	—	—	33.8 (110'11")	36.00R51
785	8GB	85-92	962 (1290)	136.0 (150.0)	96 353 (212,458)	6.64 (21'9")	11.02 (36'2")	5.77 (18'11")	4.98 (16'4")	11.20 (36'9")	30.5 (100'4")	33.00 × 51
785B	6HK	92-98	962 (1290)	136.0 (150.0)	96 353 (212,458)	6.64 (21'9")	11.02 (36'2")	5.77 (18'11")	4.98 (16'4")	11.20 (36'9")	30.2 (99'2")	33.00R51
789	9ZC	86-92	1272 (1705)	177.0 (195.0)	121 922 (268,837)	7.67 (25'2")	12.18 (39'11")	6.15 (20'2")	5.21 (17'1")	11.91 (39'1")	30.2 (99'2")	37.00R57
789B	7EK	92-98	1272 (1705)	177.0 (195.0)	121 922 (268,837)	7.67 (25'2")	12.18 (39'11")	6.15 (20'2")	5.21 (17'1")	11.91 (39'1")	30.2 (99'2")	37.00R57
789C	2BW	98-12	1417 (1900)	180.7 (199.2)	132 845 (292,873)	7.67 (25'2")	12.18 (39'11")	6.15 (20'2")	5.21 (17'1")	11.90 (39'1")	30.2 (99'2")	37.00R57
793	3SJ	90-92	1534 (2057)	218.0 (240.0)	376 482 (830,000)	7.60 (24'11")	12.86 (42'3")	6.43 (21'1")	5.86 (19'3")	13.21 (43'4")	30.2 (99'2")	40.00-57
793B	1HL	92-96	1534 (2057)	218.0 (240.0)	376 482 (830,000)	7.60 (24'11")	12.86 (42'3")	6.43 (21'1")	5.86 (19'3")	13.21 (43'4")	30.2 (99'2")	40.00R57
793C	4AR, 4GZ, ATY	96-04	1615 (2166)	218.0 (240.0)	383 739 (846,000)	7.41 (24'4")	12.87 (42'3")	6.43 (21'1")	5.86 (19'3")	13.21 (43'4")	32.4 (106'4")	40.00R57
797	5YW	98-02	2395 (3211)	326.0 (360.0)	557 820 (1,230,000)	9.14 (30'0")	14.63 (48'0")	7.24 (27'6")	7.05 (26'10")	14.94 (49'0")	32.86 (104'10")	55/80R63
797B	JSM	02-09	2513 (3370)	354.0 (394.0)	623 583 (1,375,000)	9.66 (31'9")	14.4 (47'3")	7.72 (25'4")	7.15 (23'6")	15.34 (50'4")	40.5 (132'10")	59/80/R63

ON-HIGHWAY TRUCKS				
Engine	Horsepower (BHP @ 1700 RPM)	Torque Peak (lb-ft @ 1000 RPM)	Gov. Speed (RPM)	Clutch Engagement Torque (lb-ft at 800 RPM)
CT11	330/1250	1250	2100	686
	365/1250	1250	2100	686
	370/1350	1350	2100	770
	390/1450	1450	2100	811
CT15	450/1550	1550	2100	1150
	450/1750	1750	2100	1150
	475/1850	1850	2100	1150
	500/1650	1650	2100	1150
	500/1850	1850	2100	1150
	550/1850	1850	2100	1150



ARTICULATED TRUCKS

Model	Product Ident. No. Prefix	Years Built	Flywheel Kilowatts (Horsepower)	Capacity Metric Tons (U.S. Tons)	Approx. Weight kg (lb)	Dimensions m (ft)						Tire Size
						Width	Length	Height	Loading Height	Dumping Height (55°)	Turning Circle	
D20D	9MG	92-94	134 (180)	18.0 (20.0)	15 000 (33,070)	2.75 (9'0")	8.43 (27'8")	3.30 (10'10")	2.40 (7'11")	5.00 (16'5")	7.25 (24'0")	23.5R25
D22	*	80-82	175 (235)	20.0 (22.0)	17 700 (39,000)	3.00 (9'10")	7.85 (25'9")	3.09 (10'2")	2.44 (8'0")	5.03 (16'6")	7.87 (25'10")	26.5R25
D25	*	80	175 (235)	22.7 (25.0)	17 300 (38,000)	3.00 (9'10")	7.85 (25'9")	3.09 (10'2")	2.44 (8'0")	5.03 (16'6")	7.87 (25'10")	26.5R25
D25B	*	80-83	190 (255)	22.7 (25.0)	17 900 (39,400)	3.00 (9'10")	7.99 (26'2")	3.25 (10'8")	2.44 (8'0")	5.03 (16'6")	7.87 (25'10")	26.5R25
D25C	9YC	85-89	194 (260)	22.7 (25.0)	19 233 (42,400)	3.00 (9'10")	8.73 (28'8")	3.27 (10'9")	2.56 (8'5")	5.28 (17'4")	16.14 (52'11")	26.5R25
D25D	1HK	89-01	194 (260)	22.7 (25.0)	19 450 (42,880)	3.00 (9'10")	8.79 (28'10")	3.34 (10'11")	2.63 (8'8")	5.19 (17'0")	7.95 (26'1")	26.5R25
D30C	7ZC	85-89	194 (260)	27.2 (30.0)	21 320 (47,000)	3.30 (10'10")	8.86 (29'1")	3.33 (10'11")	2.85 (9'4")	5.46 (17'11")	16.33 (53'7")	29.5R25
D30D	3AJ	89-01	213 (285)	27.2 (30.0)	21 690 (47,320)	3.30 (10'10")	8.89 (29'2")	3.40 (11'2")	2.83 (9'3")	5.46 (17'11")	8.20 (26'11")	29.5R25
D35	*	81-83	190 (255)	31.8 (35.0)	20 000 (44,000)	3.27 (10'9")	8.44 (27'8")	3.25 (10'8")	2.91 (9'7")	5.46 (17'11")	7.87 (25'10")	26.5R25 33.25R29
D35C	2GD	85-89	194 (260)	31.8 (35.0)	23 860 (52,600)	3.50 (11'6")	9.44 (31'0")	3.34 (10'11")	2.93 (9'7")	5.32 (17'5")	16.00 (52'5")	Front 29.5R25 Rear 33.5R29
D35 HP	3FD	85-89	287 (385)	31.8 (35.0)	24 950 (55,000)	3.50 (11'6")	9.80 (32'2")	3.51 (11'6")	2.93 (9'7")	5.32 (17'5")	15.78 (51'9")	Front 29.5R25 Rear 33.5R29
D40D	2JJ	89-94	287 (385)	36.3 (40.0)	28 027 (61,800)	3.48 (11'5")	9.76 (32'0")	3.56 (11'8")	3.20 (10'7")	6.00 (19'8")	7.90 (25'11")	Front 29.5R25 Rear 33.25R29
D44	*	81-86	336 (450)	40.0 (44.0)	28 000 (61,600)	3.66 (12'0")	10.05 (33'0")	3.86 (12'8")	2.90 (9'6")	6.35 (20'10")	9.96 (32'8")	33.25R29
D44B	4LD	86-87	343 (460)	40.0 (44.0)	32 296 (71,200)	3.73 (12'3")	10.05 (33'0")	3.98 (13'1")	2.98 (9'9")	6.40 (21'0")	9.08 (29'9")	33.25R29
D250	*	75-78	175 (235)	25.0 (27.5)	18 500 (40,700)	2.66 (8'9")	8.82 (29'0")	3.04 (10'0")	2.61 (8'7")	6.22 (20'5")	7.67 (25'2")	23.5R25
D250B	5WD	85-91	163 (218)	22.7 (25.0)	17 963 (39,600)	2.50 (8'2.5")	9.60 (31'8.5")	3.18 (10'5")	2.55 (8'4.5")	6.23 (20'5")	7.65 (25'1")	20.5R25
D250D	6NG	92-94	160 (214)	22.8 (25.0)	17 300 (38,150)	2.50 (8'2")	9.60 (31'6")	3.21 (10'7")	2.59 (8'6")	6.22 (20'5")	7.61 (25'0")	20.5R25
D250E	5TN	95-98	194 (260)	22.7 (25.0)	20 135 (44,397)	2.74 (9'0")	9.94 (32'7")	3.35 (11'0")	2.70 (8'10")	6.20 (20'4")	7.44 (24'5")	23.5R25
D250E Series II	4PS	98-00	201 (270)	22.7 (25.0)	21 600 (47,628)	2.88 (9'5")	10.00 (32'10")	3.35 (11'0")	2.75 (9'0")	6.39 (20'11")	7.44 (24'5")	23.5R25
725	AFX	00-05	209 (280)	23.6 (26.0)	22 730 (50,120)	2.88 (9'5")	9.92 (32'7")	3.44 (11'3")	2.75 (9'0")	6.43 (21'1")	7.26 (23'10")	23.5R25
725	B1L	05-13	230 (309)	23.6 (26.0)	22 260 (49,075)	2.88 (9'5")	9.92 (32'6")	3.44 (11'3")	2.75 (9'0")	6.41 (21'0")	7.25 (23'10")	23.5R25

*Information not available — DJB models.

Articulated Trucks (cont'd)

Model	Product Ident. No. Prefix	Years Built	Flywheel Kilowatts (Horsepower)	Capacity Metric Tons (U.S. Tons)	Approx. Weight kg (lb)	Dimensions m (ft)						Tire Size
						Width	Length	Height	Loading Height	Dumping Height (55°)	Turning Circle	
D275	*	78-80	175 (235)	25.0 (27.5)	18 700 (41,000)	2.66 (8'9")	8.82 (29'0")	3.17 (10'7")	2.61 (8'7")	6.22 (20'5")	7.75 (25'3")	23.5R25
D275B	*	80-82	190 (255)	25.0 (27.5)	19 200 (42,400)	2.66 (8'9")	8.96 (29'5")	3.21 (10'7")	2.61 (8'7")	6.22 (20'5")	7.75 (25'5")	23.5R25
D300	*	76-78	190 (255)	30.0 (33.0)	19 500 (42,900)	2.80 (9'2")	8.82 (29'0")	3.04 (10'0")	2.68 (8'10")	6.22 (20'5")	7.67 (25'2")	23.5R25
D300B	4SD	85-91	194 (260)	27.2 (30.0)	19 800 (43,520)	2.50 (8'2.5")	9.60 (31'8.5")	3.18 (10'5")	2.55 (8'4.5")	6.23 (20'5")	7.76 (25'6")	23.5R25
D300D	5MG	92-95	213 (285)	27.2 (30.0)	20 680 (45,600)	2.88 (9'6")	9.87 (32'5")	3.28 (10'9")	2.66 (8'9")	6.42 (21'1")	7.76 (25'5")	23.5R25
D300E	7FN	95-98	212 (285)	27.2 (30.0)	21 940 (48,369)	2.89 (9'6")	9.94 (32'7")	3.35 (11'0")	2.85 (9'4")	6.26 (20'6")	7.60 (24'10")	23.5R25
D300E Series II	5KS	98-00	212 (285)	27.2 (30.0)	22 793 (50,235)	2.91 (9'7")	10.00 (32'10")	3.35 (11'0")	2.89 (9'6")	6.44 (21'2")	7.60 (24'10")	23.5R25
730	AGF	00-05	228 (305)	28.1 (31.5)	23 230 (51,222)	2.88 (9'5")	9.92 (32'7")	3.44 (11'3")	2.89 (9'6")	6.50 (21'4")	7.26 (23'10")	23.5R25
730	B1M	05-13	242 (325)	28.1 (31.0)	22 850 (50,376)	2.88 (9'5")	9.92 (32'6")	3.44 (11'3")	2.90 (9'5")	6.50 (21'3")	7.25 (23'0")	23.5R25
730 Ejector	B1W	05-13	242 (325)	28.1 (31.0)	25 550 (56,328)	3.24 (10'6")	9.73 (31'9")	3.45 (11'3")	3.05 (10'0")	— (23'10")	7.25 (23'10")	750/65/R25
D330	*	78-80	190 (255)	30.0 (33.0)	20 000 (43,000)	2.80 (9'2")	8.82 (28'11")	3.17 (10'5")	2.68 (8'9")	6.22 (20'5")	7.80 (25'7")	23.5R25
D330B	*	80-83	190 (255)	30.0 (33.0)	20 200 (44,400)	2.76 (9'1")	9.08 (29'9")	3.25 (10'8")	2.68 (8'9")	6.33 (20'9")	7.92 (26'0")	23.5R25
D350	*	78-80	190 (255)	31.8 (35.0)	21 000 (46,000)	3.00 (9'10")	8.95 (29'4")	3.21 (10'7")	2.82 (9'3")	6.35 (20'10")	7.95 (26'1")	26.5R25
D350B	*	80-83	190 (255)	31.8 (35.0)	21 400 (47,200)	3.00 (9'10")	9.09 (29'10")	3.25 (10'8")	2.85 (9'4")	6.40 (21'0")	7.95 (26'1")	26.5R25
D350C	8XC	85-89	194 (260)	31.8 (35.0)	23 315 (51,400)	3.00 (9'10")	9.93 (32'7")	3.27 (10'9")	2.91 (9'6")	6.52 (21'5")	16.16 (53'0")	26.5R25
D350D	9RF	89-94	213 (285)	31.8 (35.0)	24 595 (54,221)	3.00 (9'10")	9.95 (32'7")	3.34 (11'0")	2.93 (9'7")	6.52 (21'5")	16.06 (52'8")	26.5R25
D350E	9LR	96-99	253 (340)	31.7 (35.0)	27 871 (61,455)	3.26 (10'8")	10.38 (34'1")	3.51 (11'6")	2.94 (9'8")	6.60 (21'8")	8.21 (26'11")	26.5R25
D350E Series II	2XW	99-01	265 (355)	31.8 (35.0)	30 190 (66,560)	3.26 (10'8")	10.65 (35'1")	3.51 (11'6")	2.92 (9'7")	6.83 (20'5")	8.45 (27'8")	26.5R25

*Information not available — DJB models.

Articulated Trucks (cont'd)

Model	Product Ident. No. Prefix	Years Built	Flywheel Kilowatts (Horsepower)	Capacity Metric Tons (U.S. Tons)	Approx. Weight kg (lb)	Dimensions m (ft)						Tire Size
						Width	Length	Height	Loading Height	Dumping Height (55°)	Turning Circle	
735	AWR	02-05	272 (365)	32.7 (36)	29 858 (65,825)	3.31 (10'10")	10.89 (35'9")	3.70 (12'2")	2.97 (9'10")	6.96 (22'10")	8.14 (26'9")	26.5R25
735	B1N	05-10	324 (435)	32.7 (36)	31 391 (69,206)	3.43 (11'3")	10.89 (35'7")	3.70 (12'1")	2.98 (9'8")	6.81 (22'3")	16.27 (53'4")	26.5R25
735B	T4P	11-14	326 (437)	32.7 (36)	32 549 (71,758)	3.43 (11'3")	11.00 (36'1")	3.70 (12'1")	2.98 (9'8")	6.81 (22'3")	16.27 (53'4")	26.5R25
735B	L4D	11-14	326 (437)	32.7 (36)	32 549 (71,758)	3.43 (11'3")	11.00 (36'1")	3.70 (12'1")	2.98 (9'8")	6.81 (22'3")	16.27 (53'4")	26.5R25
D400	IMD	85-89	287 (385)	36.3 (40.0)	25 765 (56,800)	3.00 (9'10")	10.42 (34'2")	3.45 (11'4")	3.00 (9'10")	6.53 (21'5")	16.07 (52'9")	26.5R25
D400D	8TF	89-95	287 (385)	36.3 (40.0)	28 027 (61,800)	3.30 (10'8")	10.62 (34'10")	3.56 (11'8")	2.98 (9'9")	6.60 (21'8")	8.26 (27'2")	29.5R25
D400E	2YR	96-99	302 (405)	36.3 (40.0)	29 263 (64,495)	3.30 (10'10")	10.52 (34'6")	3.58 (11'9")	3.07 (10'1")	6.58 (21'7")	8.26 (27'1")	29.5R25
D400E Series II	8PS	99-01	302 (405)	36.3 (40.0)	31 650 (69,760)	3.43 (11'2")	10.65 (35'1")	3.58 (11'9")	3.10 (10'2")	6.92 (23'0")	8.45 (27'8")	29.5R25
D400E II Ejector	APF	99-01	302 (405)	36.3 (40.0)	32 840 (72,380)	3.50 (11'6")	11.00 (36'1")	3.58 (11'9")	3.07 (10'1")	N/A (27'8")	8.45 (27'8")	29.5R25
740	AXM	01-05	309 (415)	38.1 (42)	32 693 (72,075)	3.43 (11'3")	10.89 (35'9")	3.75 (12'4")	3.18 (10'5")	7.07 (23'2")	8.14 (26'9")	29.5R25
740	B1P	05-10	350 (469)	39.5 (43.5)	33 100 (72,973)	3.52 (11'5")	10.89 (35'7")	3.75 (12'3")	3.24 (10'6")	7.09 (23'4")	16.27 (53'4")	29.5R25
740 Ejector	AZZ	01-05	309 (415)	38.1 (42)	35 270 (77,770)	3.50 (11'6")	11.59 (38'0")	3.75 (12'4")	3.07 (10'0")	3.07 (10'0")	8.63 (28'4")	29.5R25
740 Ejector	AZZ	01-05	309 (415)	38.1 (42)	35 270 (77,770)	3.50 (11'6")	11.59 (38'0")	3.75 (12'4")	3.07 (10'0")	3.07 (10'0")	8.63 (28'4")	29.5R25
740B	T4R	11-14	354 (474)	39.5 (43.5)	34 408 (75,857)	3.52 (11'5")	11.00 (36'1")	3.75 (12'3")	3.24 (10'6")	7.09 (23'4")	16.27 (53'4")	29.5R25
740B	L4E	11-14	352 (472)	39.5 (43.5)	34 408 (75,857)	3.52 (11'5")	11.00 (36'1")	3.75 (12'3")	3.24 (10'6")	7.09 (23'4")	16.27 (53'4")	29.5R25
740B EJ	T4S	11-14	354 (474)	38 (42)	36 984 (81,536)	3.53 (11'6")	11.70 (38'4")	3.75 (12'3")	3.07 (10'0")	— (56'7")	17.28 (56'7")	29.5R25
740B EJ	L4F	11-14	352 (472)	38 (42)	36 984 (81,536)	3.53 (11'6")	11.70 (38'4")	3.75 (12'3")	3.07 (10'0")	— (56'7")	17.28 (56'7")	29.5R25
D550	*	78-86	336 (450)	50.0 (55.0)	37 800 (83,400)	3.66 (12'0")	11.35 (37'3")	3.86 (12'8")	3.30 (10'10")	7.83 (25'8")	9.65 (31'8")	33.25R29
D550B	8SD	86-87	343 (460)	50.0 (55.0)	40 370 (89,000)	3.72 (12'2.5")	11.74 (38'6")	3.97 (13'0")	3.22 (10'6")	8.28 (27'2")	8.73 (28'8")	33.25R29

*Information not available — DJB models.



WHEEL DOZERS

Model	Product Ident. No. Prefix	Years Built	Flywheel Kilowatts (Horsepower)	Approx. Oper. Wt. kg (lb)	Length (Dozer on ground)		Wheelbase m (ft)	Ground Clearance mm (in)	Transmission	Maximum Speeds km/h (mph)		
					m (ft)	Tread m (ft)				Fwd.	Rev.	
814B	90P	70-81	127 (170)	18 780 (41,400)	6.49 (21'3")	2.16 (7'1")	3.10 (10'2")	356 (14)	PS 4F-4R	32.7 (20.3)	39.3 (24.4)	*
814B	16Z	81-95	161 (216)	20 927 (46,137)	6.82 (22'5")			459 (18)	PS 4F-4R	29.9 (18.6)	34.1 (21.2)	*
814F	9DM	96-02	164 (220)	22 780 (50,115)		2.20 (7'3")	3.35 (11'0")	448 (18)	PS 4F-4R	29.9 (18.6)	34.1 (21.2)	
814F	BGF	03-06	179 (240)	21 713 (47,877)	6.82 (22'5")	2.20 (7'3")	3.35 (11'0")	448 (18)	PS 4F-4R	29.9 (18.6)	34.1 (21.2)	
814F II	BXG	06	173 (232)	20 755 (45,765)	6.90 (22'6")	2.20 (7'3")	3.60 (11'8")	366 (14)	PS 4F-4R	31 (19.3)	34.9 (21.8)	
824	29G	63-65	224 (300)	31 700 (70,000)	7.04 (23'1")	2.37 (7'10")	3.35 (11'8")	470 (18.2)	PS 3F-3R	34.1 (21.2)	34.1 (21.2)	
824B	36H	65-78	224 (300)	33 330 (73,480)	7.40 (24'3.5")	2.32 (7'7.5")	3.55 (11'8")	490 (19.4)	PS 3F-3R	29.8 (18.5)	29.8 (18.5)	
824C	85X	78-95	235 (315)	30 380 (66,975)	7.69 (25'2")	2.36 (7'7.5")	3.53 (11'7")	477 (18.8)	PS 4F-4R	33.2 (20.6)	37.8 (23.5)	
824G	4SN	96-02	235 (315)	26 620 (58,697)	8.02 (26'4")	2.44 (8'0")	3.70 (12'2")	383 (15)	PS 4F-4R	33 (20.4)	37.8 (23.5)	
824G II	AXB	03-04	253 (339)	28 724 (63,325)	8.02 (26'4")	2.44 (8'0")	3.70 (12'2")	383 (15)	PS 4F-4R	32.1 (20)	36.6 (22.7)	
824H	ASX	05-14	264 (354)	28 724 (63,325)	8.20 (26'9")	2.44 (8'0")	3.70 (12'2")	358 (14)	PS 4F-4R	32.1 (20)	36.6 (22.7)	
834	43E	63-74	298 (400)	40 300 (88,800)	7.75 (25'5")	2.54 (8'4")	3.80 (12'6")	510 (20.0)	PS 3F-3R	32.8 (20.4)	35.7 (22.2)	
834B	7BR	74-00	336 (450)	46 350 (102,200)	8.72 (28'7")		3.81 (12'6")	466 (18)	PS 4F-4R	34.1 (21.2)	41.8 (25.9)	
834G	6GZ	98-01	359 (481)	44 680 (98,500)	10.40 (34'2")	2.59 (8'6")	4.55 (14'11")	541 (21)	PS 4F-3R	38.5 (23.9)	23.0 (14.3)	**
834G	BPC	02-04	359 (481)	47 106 (103,849)	10.40 (34'2")	2.59 (8'6")	4.55 (14'11")	541 (21)	PS 4F-3R	38.5 (23.9)	23.0 (14.3)	
834H	BTX	05-13	372 (489)	47 106 (103,849)	10.42 (34'2")	2.59 (8'6")	4.55 (14'11")	531 (21)	PS 4F-3R	35.4 (22)	21.4 (13.3)	
844	2KZ	98-01	466 (625)	69 230 (152,620)	10.90 (35'9")	3.10 (10'0")	4.60 (15'1")	552 (22)	PS 3F-3R	22.5 (14.0)	25.0 (15.5)	***
844	BBN	01-05	466 (625)	70 815 (156,120)	10.90 (35'9")	3.10 (10'0")	4.60 (15'1")	552 (22)	PS 3F-3R	22.5 (14.0)	25.0 (15.5)	
844H	BTW	05-14	468 (627)	70 815 (156,120)	10.94 (35'9")	3.10 (10'0")	4.60 (15'1")	475 (19)	PS 3F-3R	21 (13)	23 (14.3)	
854G	1JW	97-99	597 (800)	99 400 (219,125)	13.40 (44'0")	3.30 (10'10")	5.89 (19'3")	691 (27)	PS 3F-3R	20.5 (12.7)	22.7 (14.1)	****
854G	AMP	00-04	597 (800)	99 400 (219,125)	13.40 (44'0")	3.30 (10'10")	5.39 (19'3")	691 (27)	PS 3F-3R	20.5 (12.7)	22.7 (14.1)	
854G	A4W	04-08	597 (800)	99 400 (219,125)	13.40 (44'0")	3.30 (10'10")	5.39 (19'3")	691 (27)	PS 3F-3R	20.5 (12.7)	22.7 (14.1)	
854K	221	08-11	597 (801)	98 100 (216,273)	13.45 (44'0")	3.30 (10'10")	5.89 (19'3")	691 (27)	PS 3F-3R	21.2 (13.2)	23.5 (14.6)	

*Turbocharged, Articulated Steering.

**Move to "G" Series.

***New model from Tiger (590).

****New model from Tiger (790).



COMPACTORS

Model	Product Ident. No. Prefix	Years Built	Flywheel Kilowatts (Horsepower)	Approx. Oper. Wt. kg (lb)	Drum Width m (ft)	Articulated Steering Angle, Maximum	Transmission	Maximum Speeds km/h (mph)		
								Fwd.	Rev.	
815	91P	70-81	127 (170)	17 300 (38,200)	0.97 (3'2")	44° Either Side	Power Shift 4F-4R	30.1 (18.7)	35.7 (22.2)	*
815B	17Z	81-95	161 (216)	20 035 (44,175)	0.98 (3'2")	45° Either Side	Power Shift 4F-4R	37.5 (23.3)	42.9 (26.6)	*
815F	1GN	96-02	164 (220)	20 952 (46,096)	0.98 (3'2")	36° Either Side	Power Shift 4F-4R	37.6 (23.3)	43.0 (26.7)	
815F	BKL	03-06	179 (240)	20 755 (45,765)	0.98 (3'2")	36° Either Side	Power Shift 3F-3R	17.9 (11.1)	19.5 (12.1)	
815F II	BYN	06	173 (232)	20 755 (45,756)	0.99 (3'3")	42° Either side	Power Shift 3F-3R	17.6 (11.0)	19.5 (12.2)	
816	57U	72-81	127 (170)	18 550 (40,900)	1.02 (3'4")	44° Either Side	Power Shift 4F-4R	30.1 (18.6)	35.7 (22.4)	**
816B	15Z	81-95	161 (216)	20 628 (45,477)	1.02 (3'4")	42° Either Side	Power Shift 4F-4R	35.3 (22.0)	40.4 (25.1)	**
816F	5FN	96-02	164 (220)	20 879 (45,934)	1.02 (3'4")	42° Either Side	Power Shift 4F-4R	36.3 (22.5)	41.4 (25.7)	
816F II	BZR	06	173 (232)	23 748 (52,364)	1.016 (3'4")	42° Either side	Power Shift 2F-2R	9.5 (5.9)	10.6 (6.6)	
825B	43N	70-78	224 (300)	30 075 (66,300)	1.13 (3'8")	44° Either Side	Power Shift 4F-4R	29.8 (18.5)	29.8 (18.5)	
825C	86X	78-96	231 (310)	32 400 (71,432)	1.13 (3'8")	42° Either Side	Power Shift 4F-4R	29.8 (18.5)	33.9 (21.1)	
825G	6RN	96-02	235 (315)	31 740 (69,828)	1.13 (3'8")	42° Either Side	Power Shift 3F-3R	15.6 (9.7)	17.2 (10.7)	
825G II	AXB	03-04	253 (339)	32 734 (72,164)	1.13 (3'8")	42° Either Side	Power Shift 3F-3R	15.6 (9.7)	17.2 (10.7)	
825H	AZW	05-14	264 (354)	32 734 (72,164)	1.125 (3'7")	42° Either side	Power Shift 3F-3R	15.6 (9.7)	17.2 (10.7)	
826C	87X	78-95	235 (315)	34 920 (76,990)	1.20 (3'11")	42° Either Side	Power Shift 4F-4R	32.5 (20.2)	37.2 (23.1)	
826G	7LN	96-02	235 (315)	33 350 (73,537)	1.20 (3'11")	42° Either Side	Power Shift 2F-2R	11.2 (6.9)	13.5 (8.4)	
826H	AWF	05-14	264 (354)	36 967 (81,498)	1.20 (3'11")	42° Either side	Power Shift 2F-2R	9.7 (6.03)	10.6 (6.59)	
835	44N	70-74	298 (400)	35 900 (79,100)	1.22 (4'0")	44° Either Side	Power Shift 3F-3R	32.2 (20.0)	34.8 (21.6)	
836	3RL	93-95	336 (450)	45 450 (100,000)	1.40 (4'7")	35° Either Side	Power Shift 2F-2R	11.3 (7.0)	14.0 (8.7)	*
836G	7MZ	98-01	351 (471)	53 680 (118,348)	1.40 (4'7")	35° Either Side	Power Shift 2F-2R	6.0 (3.7)	10.2 (6.3)	
836H	BXD	05-13	372 (499)	53 682 (118,348)	1.40 (4'7")	35° Either side	Power Shift 2F-2R	10.9 (6.8)	11.4 (7.1)	

*Turbocharged, Articulated Steering.

**Turbocharged, ROPS Cab, Sleeve Metering Fuel System.



WHEEL LOADERS

Model	Product Ident. No. Prefix	Years Built	Flywheel Horse-power	Approx. Shipping Wt. kg (lb)	Rated Capacity m ³ (yd ³)	Breakout Force kg (lb)	Width Over Tires m (ft)	Ground Clearance mm (in)	Max. Reach at max. height mm (ft)	Dump Clearance at max. height m (ft)	Maximum Speeds km/h (mph)		Remarks
											Fwd.	Rev.	
904B	B4L	05-08	52	4368 (9630)	0.6 (0.8)	3633 (8009)	1.70 (5'7")	218 (8.6)	664 (2'2")	2.38 (7'10")	20.0 (12.4)	20.0 (12.4)	
906H		07-12	70	5630 (12,412)	0.9 (1.2)	4283 (9442)	1.84 (6'0")	300 (11.8)	810 (2'8")	2.40 (7'10")	35.0 (22.0)	35.0 (22.0)	
906H2		12-15	71	5630 (12,412)	0.9 (1.2)	4283 (9442)	1.84 (6'0")	300 (11.8)	810 (2'8")	2.40 (7'10")	35.0 (22.0)	35.0 (22.0)	
907H		07-12	70	5810 (12,809)	1.0 (1.3)	4283 (9442)	1.84 (6'0")	300 (11.8)	810 (2'8")	2.40 (7'10")	35.0 (22.0)	35.0 (22.0)	
907H2		12-15	71	5810 (12,809)	1.0 (1.3)	4283 (9442)	1.84 (6'0")	300 (11.8)	810 (2'8")	2.40 (7'10")	35.0 (22.0)	35.0 (22.0)	
908H		07-12	79	6465 (14,253)	1.1 (1.4)	4793 (10,566)	1.99 (6'6")	340 (13.0)	855 (2'10")	2.50 (8'3")	35.0 (22.0)	35.0 (22.0)	
908H2		12-15	71	6465 (14,253)	1.1 (1.4)	4793 (10,566)	1.99 (6'5")	340 (13.0)	855 (2'10")	2.50 (8'3")	35.0 (22.0)	35.0 (22.0)	
910	80V	73-79	65	6100 (13,400)	1.0 (1.25)	4530 (10,000)	2.07 (6'10")	405 (16)	860 (2'10")	2.46 (8'1")	24.1 (15.0)	10.6 (6.6)	
910	40Y	79-89	65	6658 (14,679)	1.0 (1.25)	5838 (12,870)	2.07 (6'10")	405 (16)	930 (3'0.6")	2.40 (7'10")	23.9 (14.8)	10.6 (6.6)	
910	41Y	79-89	65	6658 (14,679)	1.0 (1.25)	5838 (12,870)	2.07 (6'10")	405 (16)	930 (3'0.6")	2.40 (7'10")	23.5 (14.6)	24.9 (15.5)	
910E	1SF	89-92	78	7298 (16,062)	1.3 (1.7)	6503 (14,339)	2.15 (7'0")	343 (13.5)	1000 (3'3.4")	2.57 (8'5")	34.0 (21.1)	22.4 (13.9)	3114 Engine Z Bar Linkage
910F	1SF	92-95	80	7009 (15,452)	1.3 (1.7)	6443 (14,207)	2.15 (7'0")	370 (14.6)	981 (3'3")	2.60 (8'6")	34.0 (21.1)	22.4 (13.9)	3114 Engine Z Bar Linkage
914G	7ZM 9WM PDF	95-14	95	7950 (17,530)	1.2-1.4 (1.6-1.8)	6200 (14,007)	2.258 (7'5")	456 (16.3)	973 (3'2")	2.659 (8'9")	35.0 (22.0)	35.0 (22.0)	C4.4 ACERT Engine Z Bar Linkage Hystat Transmission
914G2	KNP	12-14	95	7950 (17,530)	1.2-1.4 (1.6-1.8)	6200 (14,007)	2.258 (7'5")	456 (16.3)	973 (3'2")	2.659 (8'9")	35.0 (22.0)	35.0 (22.0)	C4.4 ACERT Engine Z Bar Linkage Hystat Transmission
916	2XB	86-92	85	8554 (18,857)	1.4 (1.75)	9124 (20,115)	2.33 (7'8")	322 (12.7)	926 (3'0.5")	2.65 (8'9")	24.8 (15.4)	25.0 (15.5)	3204 Engine Z Bar Linkage
918F	3TJ	92-94	98	8973 (19,785)	1.5 (2.0)	9795 (21,598)	2.33 (91.6")	318 (13)	802 (2'8")	2.78 (9'1")	37.0 (23.0)	24.5 (15.2)	3114 Engine Z Bar Linkage
920	62K	69-84	80	8440 (18,600)	1.2 (1.5)	7901 (17,419)	2.16 (7'1")	335 (13)	740 (2'5")	2.77 (9'1")	43.8 (27.2)	23.2 (14.4)	
922A	59A	60-62	80	7350 (16,200)	0.93 (1.25)	6850 (15,100)	2.12 (7'0")	368 (15)	655 (2'2")	2.60 (8'7")	30.4 (18.9)	32.8 (20.4)	
922B	88J	62-68	80	7670 (16,900)	1.15 (1.5)	9000 (19,900)	2.25 (7'5")	390 (16)	680 (2'3")	2.60 (8'7")	33.6 (20.9)	42.9 (26.7)	

Wheel Loaders (cont'd)

Model	Product Ident. No. Prefix	Years Built	Flywheel Horse-power	Approx. Shipping Wt. kg (lb)	Rated Capacity m ³ (yd ³)	Breakout Force kg (lb)	Width Over Tires m (ft)	Ground Clearance mm (in)	Max. Reach at max. height mm (ft)	Dump Clearance at max. height m (ft)	Maximum Speeds km/h (mph)		Remarks
											Fwd.	Rev.	
924F	5NN	94-99	105	9025 (19,900)	1.7 (2.25)	9553 (21,067)	2.33 (7'6")	318 (12.5)	855 (2'8")	2.70 (8'10")	38.2 (23.6)	23.6 (14.8)	
924G	9SW	99-02	120	9615 (21,197)	1.8 (2.3)	9876 (21,772)	2.36 (7'9")	370 (15)	1318 (4'4")	2.828 (9'4")	38.5 (23.9)	21.8 (13.5)	
924G	3PZ	99-02	120	9615 (21,197)	1.8 (2.3)	9876 (21,772)	2.36 (7'9")	370 (15)	1318 (4'4")	2.828 (9'4")	38.5 (23.9)	21.8 (13.5)	
924G	AAN	99-02	120	9615 (21,197)	1.8 (2.3)	9876 (21,772)	2.36 (7'9")	370 (15)	1318 (4'4")	2.828 (9'4")	38.5 (23.9)	21.8 (13.5)	
924G	DDA	02-07	129	9977 (21,996)	1.8 (2.3)	11 452 (25,247)	2.36 (7'9")	370 (15)	1451 (4'10")	2.918 (9'7")	38.5 (23.9)	21.8 (13.5)	
924G	RBB	02-07	129	9977 (21,996)	1.8 (2.3)	11 452 (25,247)	2.36 (7'9")	370 (15)	1451 (4'10")	2.918 (9'7")	38.5 (23.9)	21.8 (13.5)	
924G	WMB	02-07	129	9977 (21,996)	1.8 (2.3)	11 452 (25,247)	2.36 (7'9")	370 (15)	1451 (4'10")	2.918 (9'7")	38.5 (23.9)	21.8 (13.5)	
924Gz	6YW	99-02	120	9615 (21,197)	1.8 (2.3)	9876 (21,772)	2.36 (7'9")	370 (15)	1318 (4'4")	2.828 (9'4")	38.5 (23.9)	21.8 (13.5)	
924Gz	3DZ	99-03	120	9615 (21,197)	1.8 (2.3)	9876 (21,772)	2.36 (7'9")	370 (15)	1318 (4'4")	2.828 (9'4")	38.5 (23.9)	21.8 (13.5)	
924Gz	AAB	99-04	120	9615 (21,197)	1.8 (2.3)	9876 (21,772)	2.36 (7'9")	370 (15)	1318 (4'4")	2.828 (9'4")	38.5 (23.9)	21.8 (13.5)	
924Gz	DFZ	02-04	129	9615 (21,197)	1.8 (2.3)	9876 (21,772)	2.36 (7'9")	370 (15)	1318 (4'4")	2.828 (9'4")	38.5 (23.9)	21.8 (13.5)	
924Gz	RTA	02-07	129	9615 (21,197)	1.8 (2.3)	9876 (21,772)	2.36 (7'9")	370 (15)	1318 (4'4")	2.828 (9'4")	38.5 (23.9)	21.8 (13.5)	
924Gz	WGX	02-07	129	9615 (21,197)	1.8 (2.3)	9876 (21,772)	2.36 (7'9")	370 (15)	1318 (4'4")	2.828 (9'4")	38.5 (23.9)	21.8 (13.5)	
924H	HXC	07-13	132	11 635 (25,651)	2.1 (2.7)	9003 (19,848)	2.49 (8'2")	436 (17)	1060 (3'6")	2.759 (9'1")	39.7 (24.7)	22.9 (14.2)	
924Hz	JZZ	10-13	132	11 021 (24,297)	2.1 (2.7)	8975 (19,787)	2.49 (8'2")	436 (17)	859 (2'10")	2.757 (9'1")	39.7 (24.7)	22.9 (14.2)	
926	94Z	84-87	105	8800 (19,400)	1.21 (1.75)	5070 (11,179)	2.33 (7'8")	341 (13.5)	924 (3'0")	2.67 (8'9")	30.3 (18.8)	32.3 (20.0)	
926E	94Z	87-92	110	9432 (20,794)	1.7 (2.25)	10 044 (22,143)	2.33 (7'8")	341 (13.5)	1003 (3'3.5")	2.75 (9'0")	34.2 (21.2)	36.8 (22.9)	3204 Engine Z Bar Linkage
928F	2XL	93-96	120	10 870 (23,920)	2.1 (2.75)	10 090 (22,200)	2.43 (8'0")	318 (13)	956 (3'2")	2.74 (9'0")	36.5 (22.6)	21.1 (13.1)	3116 Engine Z Bar Linkage
928G	6XR	96-02	125	11 250 (24,802)	2.0 (2.6)	11 723 (25,849)	2.44 (8'0")	408 (16)	1455 (4'9")	2.879 (9'5")	37.7 (23.4)	25.8 (16)	
928G	7SR	96-02	125	11 250 (24,802)	2.0 (2.6)	11 723 (25,849)	2.44 (8'0")	408 (16)	1455 (4'9")	2.879 (9'5")	37.7 (23.4)	25.8 (16)	
928Gz	DJD	02-07	143	11 250 (24,802)	2.0 (2.6)	11 723 (25,849)	2.44 (8'0")	408 (16)	1455 (4'9")	2.879 (9'5")	37.7 (23.4)	25.8 (16)	
928Gz	WLG	02-07	143	11 250 (24,802)	2.0 (2.6)	11 723 (25,849)	2.44 (8'0")	408 (16)	1455 (4'9")	2.879 (9'5")	37.7 (23.4)	25.8 (16)	
928Hz	CXK	07-13	152	12 618 (27,818)	2.3 (3.0)	9002 (19,846)	2.57 (8'5")	408 (16)	963 (3'2")	2.842 (9'4")	37.6 (23.4)	26.7 (16.6)	

Wheel Loaders (cont'd)

Model	Product Ident. No. Prefix	Years Built	Flywheel Horse-power	Approx. Shipping Wt. kg (lb)	Rated Capacity m ³ (yd ³)	Breakout Force kg (lb)	Width Over Tires m (ft)	Ground Clearance mm (in)	Max. Reach at max. height mm (ft)	Dump Clearance at max. height m (ft)	Maximum Speeds km/h (mph)		Remarks
											Fwd.	Rev.	
930	41K	68-85	100	9660 (21,300)	1.7 (2.25)	7900 (17,410)	2.39 (7'10")	348 (13.7)	1350 (3'9")	2.79 (9'2")	44.2 (27.5)	23.3 (14.5)	Z Bar Linkage
930G	TWR	05-07	149	12 756 (28,122)	2.3 (3.0)	14 567 (32,115)	2.41 (7'11")	421 (16)	1542 (5'1")	2.917 (9'7")	38.3 (23.8)	24.1 (15)	
930G	TFR	05-07	149	12 756 (28,122)	2.3 (3.0)	14 567 (32,115)	2.41 (7'11")	421 (16)	1542 (5'1")	2.917 (9'7")	38.3 (23.8)	24.1 (15)	
930H	DHC	07-13	152	13 174 (29,044)	2.3 (3.0)	12 852 (28,334)	2.57 (8'5")	411 (16)	995 (3'3")	2.773 (9'1")	39.7 (24.7)	22.9 (14.2)	
936	33Z	83-87	125	11 884 (26,200)	2.1 (2.75)	12 514 (28,708)	2.56 (8'4.5")	329 (13)	1055 (3'0")	2.80 (9'2")	34.4 (21.4)	38.4 (23.9)	Box Frame
936E	33Z	87-92	135	12 300 (27,000)	2.3 (3.0)	12 920 (28,483)	2.56 (8'5")	379 (14.9)	1026 (2'11")	2.87 (9'2")	40.6 (25.2)	45.3 (28.2)	
936F	8AJ	92-94	140	12 300 (27,060)	2.3 (3.0)	12 920 (28,483)	2.58 (8'5")	379 (14.9)	997 (3'3")	2.84 (9'4")	42.3 (26.3)	46.7 (29.6)	
938F		94-97	140	13 030 (28,730)	2.5 (3.25)	12 330 (27,180)	2.61 (8'7")	400 (16)	1004 (3'4")	2.85 (9'4")	37.9 (23.6)	22.0 (13.7)	Wet Disc Brakes
938G	4YS	97-02	160	12 962 (28,578)	2.8 (3.65)	11 227 (24,770)	2.60 (8'6")	400 (16)	1055 (3'6")	2.72 (8'11")	39.4 (24.5)	23.4 (14.5)	Series II
938G	CRD	02-07	160	13 452 (29,656)	2.8 (3.66)	11 156 (24,594)	2.60 (8'6")	400 (16)	1068 (3'6")	2.771 (9'1")	38.8 (24.1)	23.3 (14.5)	
938H	MJC	05-12	197	14 919 (32,881)	2.5 (3.3)	13 751 (30,316)	2.65 (8'8")	397 (16)	1019 (3'4")	2.849 (9'4")	41.1 (25.5)	25.0 (15.5)	
944	87J	59-68	100	10 100 (22,000)	1.53 (2.0)	9800 (21,700)	2.40 (7'10")	450 (18)	905 (3'0")	2.96 (9'9")	38.5 (23.9)	46.6 (28.9)	
950	81J	68-81	130	12 930 (28,500)	1.53 (2.07)	10 320 (22,760)	2.41 (7'11")	381 (15)	740 (2'5")	2.82 (9'3")	35.9 (22.3)	42.5 (26.4)	Articulated Steering, 4 Wheel Drive
950B	22Z	81-87	155	14 650 (32,300)	2.9 (3.75)	15 680 (35,895)	2.67 (5'9")	427 (16.8)	1125 (3'8")	2.95 (9'8")	36.4 (22.6)	39.4 (24.5)	Z Bar Linkage
950E	22Z	87-91	160	15 856 (34,883)	3.1 (4.0)	13 586 (29,925)	2.76 (9'0")	400 (15.7)	1160 (3'10")	2.85 (9'4")	36.2 (22.4)	39.9 (24.7)	23.5-25 Std. Tires
950F	7ZF	90-92	170	16 086 (35,463)	3.1 (4.0)	14 954 (32,974)	2.76 (9'0")	474 (18.7)	1160 (3'10")	2.85 (9'4")	39.3 (24.4)	43.0 (26.7)	Wet Disc Brakes
950F	5SK	93-98	170	16 880 (37,220)	3.1 (4.0)	14 960 (32,980)	2.76 (9'0")	460 (18.1)	1180 (3'10")	2.83 (9'3")	38.7 (24.0)	42.7 (26.5)	Integral ROPS Electronic Shift
950G	3JW	98-02	183	16 904 (37,266)	3.5 (4.5)	14 888 (32,810)	2.89 (9'6")	400 (16)	1270 (4'2")	2.89 (9'6")	37.0 (23.0)	40.7 (25.3)	Series II
950G	4BS			17 780 (39,198)	3.1 (4.05)	15 724 (34,666)	2.89 (9'6")	412 (16.2)	1202 (3'11")	2.92 (9'7")	37.0 (23.0)	40.0 (24.9)	
950G	AXX	02-05	183	17 780 (39,198)	3.1 (4.05)	15 724 (34,666)	2.89 (9'6")	412 (16.2)	1202 (3'11")	2.92 (9'7")	37.0 (23.0)	40.0 (24.9)	
960F	9ZJ	94-98	200	18 070 (39,840)	3.5 (4.5)	14 500 (31,970)	2.77 (9'1")	454 (17.9)	1030 (3'5")	2.92 (9'6")	39.4 (24.5)	43.2 (26.8)	Material Handler
962G	4PW	98-02	200	17 941 (39,553)	3.8 (5.0)	14 480 (31,950)	2.90 (9'8")	400 (16)	1250 (4'2")	2.77 (9'2")	37.0 (23.0)	40.7 (25.3)	Series II
962G	5AS			18 547 (40,889)	3.5 (4.58)	14 072 (31,024)	2.89 (9'6")	412 (16.2)	1308 (4'2")	2.81 (9'2")	37.0 (23.0)	40.0 (24.9)	
962G	AXY	02-05	204	18 547 (40,889)	3.5 (4.58)	14 072 (31,024)	2.89 (9'6")	412 (16.2)	1308 (4'2")	2.81 (9'2")	37.0 (23.0)	40.0 (24.9)	

Wheel Loaders (cont'd)

Model	Product Ident. No. Prefix	Years Built	Flywheel Horse-power	Approx. Shipping Wt. kg (lb)	Rated Capacity m ³ (yd ³)	Breakout Force kg (lb)	Width Over Tires m (ft)	Ground Clearance mm (in)	Max. Reach at max. height mm (ft)	Dump Clearance at max. height m (ft)	Maximum Speeds km/h (mph)		Remarks	
											Fwd.	Rev.		
966A	33A	60-63	140	13 060 (28,800)	2.10 (2.75)	13 470 (29,700)	2.70 (8'10")	450 (18)	900 (3'0")	2.95 (9'8")	43.0 (26.7)	51.5 (32.3)		
966B	75A	63-68	150	14 300 (31,500)	2.29 (3.0)	14 000 (31,000)	2.70 (8'10")	400 (16)	900 (3'0")	2.95 (9'8")	38.5 (23.9)	46.3 (28.8)		
966C	76J	68-81	170	16 730 (36,890)	3.1 (4.0)	11 600 (25,578)	2.77 (9'1")	400 (15.7)	1420 (4'8")	2.95 (9'8")	38.0 (23.6)	45.1 (28.0)		
966D	99Y	80-87	200	19 730 (43,500)	3.3 (4.25)	20 972 (48,150)	2.86 (9'4.8")	451 (17.8)	1230 (4'0")	3.14 (10'3.5")	34.3 (21.3)	38.1 (23.7)	Z Bar Linkage	
966E	99Y	87-90	216	20 324 (44,767)	3.8 (5.0)	18 939 (41,715)	2.94 (9'8")	476 (18.7)	1290 (4'3")	2.97 (9'9")	38.2 (23.7)	43.6 (27.0)	26.5-25 Std. Tires	
966F	4YG	90-93	220	20 466 (45,119)	3.8 (5.0)	20 493 (45,187)	2.94 (9'8")	476 (18.7)	1280 (4'2")	2.98 (9'9")	37.6 (23.4)	42.6 (26.4)	Wet Disc Brakes	
966F	1SL	93-98	220	21 290 (46,950)	3.8 (5.0)	20 490 (45,180)	2.94 (9'8")	476 (18.7)	1277 (4'2")	2.98 (9'9")	38.8 (24.1)	43.9 (27.3)	Integral ROPS	
Series II	966G	3SW	98-02	235	22 068 (48,651)	4.0 (5.25)	19 986 (44,120)	2.97 (9'9")	565 (22)	1295 (4'3")	3.10 (10'2")	37.1 (23.1)	42.2 (26.2)	Electronic Shift
966G	ANZ	01-05	246	22 870 (50,400)	4.25 (5.5)	19 273 (42,477)	3.04 (9'11")	471 (18.5)	1328 (4'4")	3.07 (10'0")	37.2 (23.1)	38.5 (23.9)		
Series II	966K XE	ANT	12-14	299	24 189 (53,311)	4.2 (5.5)	17 641 (38,984)	2.99 (9'9")	475 (18.7)	1388 (4'6")	2.99 (9'9")	40.0 (24.9)	28.0 (17.4)	Advanced Power Train
970F	7SK	93-98	250	23 690 (52,240)	4.7 (6.0)	16 510 (36,400)	2.94 (9'8")	482 (19)	1357 (4'5")	3.22 (10'6")	37.3 (23.2)	42.7 (26.5)	Material Handler New Model	
972G	4WW	98-02	265	24 468 (53,942)	4.7 (6.0)	21 618 (47,580)	2.97 (9'9")	565 (22)	1255 (4'1")	3.15 (10'4")	37.0 (22.9)	41.9 (26.0)		
972G	AWP	01-05	270	25 490 (56,180)	4.7 (6.0)	22 036 (48,554)	2.95 (9'9")	565 (22.2)	1325 (4'4")	3.23 (10'7")	36.9 (22.9)	38.8 (24.0)		
Series II	980	42H	66-70	235	20 000 (44,000)	3.06 (4.0)	18 860 (41,570)	2.87 (9'5")	399 (16)	1190 (3'11")	3.07 (10'1")	42.0 (26.1)	26.7 (16.6)	
980B	89P	70-78	260	23 360 (51,500)	3.44-4.21 (4.5-5.5)	15 900 (35,100)	3.11 (10'2")	— (—)	1120 (3'8")	3.20 (10'6")	43.0 (26.7)	27.4 (17.0)		
980C	63X	79-91	270	27 559 (60,755)	5.2 (6.75)	23 188 (51,121)	3.15 (10'4")	417 (16.4)	1480 (4'10")	3.19 (10'6")	34.6 (21.5)	39.6 (24.5)	Dual Z Bar Linkage	
980F	8JN	91-92	275	27 580 (60,800)	5.3 (7.0)	23 188 (51,121)	3.15 (10'4")	469 (18.5)	1500 (4'11")	3.16 (10'5")	37.4 (23.2)	42.8 (26.6)	Electronic Shift	
980F	4RN	92-95	275	27 580 (60,800)	5.3 (7.0)	23 188 (51,121)	3.15 (10'4")	469 (18.5)	1500 (4'11")	3.16 (10'5")	37.4 (23.2)	42.8 (26.6)		
Series II	980G	2KR	95-01	300	29 480 (65,000)	5.4 (7.0)	23 760 (52,390)	3.25 (10'8")	467 (18.4)	1540 (5'1")	3.27 (10'8")	37.4 (23.2)	42.8 (26.6)	
980G	AWH	01-05	311	30 207 (66,576)	5.7 (7.5)	21 414 (47,277)	3.25 (10'8")	467 (18.4)	1545 (5'1")	3.27 (10'9")	37.4 (23.2)	42.8 (26.6)		
Series II														

Wheel Loaders (cont'd)

Model	Product Ident. No. Prefix	Years Built	Flywheel Horse-power	Approx. Shipping Wt. kg (lb)	Rated Capacity m ³ (yd ³)	Breakout Force kg (lb)	Width Over Tires m (ft)	Ground Clearance mm (in)	Max. Reach at max. height mm (ft)	Dump Clearance at max. height m (ft)	Maximum Speeds km/h (mph)		Remarks
											Fwd.	Rev.	
988	87A	63-76	325	35 800 (79,000)	4.6-5.4 (6.0-7.0)	21 380 (47,130)	3.20 (10'7")	570 (22.5)	1450 (4'9")	3.33 (10'11")	30.6 (19.0)	30.6 (19.0)	
988B	50W	76-93	375	43 365 (95,600)	5.4-6.3 (7.0-8.25)	36 330 (80,100)	3.52 (11'7")	474 (18)	2150 (7'1")	3.19 (10'5")	36.2 (22.5)	41.4 (25.7)	3408 Engine Z Bar Linkage
988F	8YG	93-95	400	43 540 (95,900)	5.4-6.1 (7.0-8.0)	37 363 (82,371)	3.52 (11'7")	496 (19)	1830 (6'0")	3.21 (10'6")	35.1 (21.8)	23.5 (14.6)	Bucket/HP increase STIC Steer
988F	2ZR	95-00	475	45 678 (100,492)	6.1-6.9 (8.0-9.0)	45 678 (80,000)	3.52 (11'7")	496 (19)	1611 (5'3")	3.22 (10'7")	35.1 (21.8)	23.5 (14.6)	3408E Engine Axle Shaft Brakes
988G	2TW BNH	01-05	475	50 040 (110,320)	6.3-7.0 (8.2-9.2)	46 950 (103,500)	3.47 (11'5")	549 (21.6)	2113 (6'11")	4.00 (13'1")	38.7 (24.0)	22.3 (13.8)	4.25 m 6 Bar Linkage
988H	BXY A7A	05-15	501	50 144 (110,549)	6.4-7.7 (8.3-10)	41 531 (91,560)	3.47 (11'5")	549 (21.6)	2153 (7'1")	3.31 (10'10")	38.6 (24.0)	25.1 (15.6)	3.88 m 6 Bar Linkage
990	7HK	93-95	610	72 910 (160,600)	8.6 (11.2)	59 776 (131,784)	4.13 (13'6")	552 (21.7)	2070 (6'10")	3.99 (13'1")	22.5 (14.0)	25.0 (15.5)	ICTC & New Model
990	4FR	96-05	625	72 200 (159,170)	8.4-9.2 (11-12)	63 100 (138,800)	4.00 (13'1")	490 (19.3)	1990 (6'6")	4.05 (13'3")	22.5 (14.0)	25.0 (15.5)	3412E Engine
990H	BWX	05-14	627	77 842 (171,642)	8.6-9.2 (11.25-12)	602 (135,429)	4.16 (13'3")	478 (18.8)	8.07 (26'6")	4220 (13'10")	22.4 (13.92)	24.8 (15.41)	Standard Lift 8.6 m ³ /11.2 yd ³ Bucket
992	25K	68-73	550	47 670 (105,100)	7.65 (10.0)	36 900 (81,360)	3.93 (12'11")	530 (21)	2820 (8'3")	4.52 (14'10")	35.6 (22.1)	38.5 (23.8)	
992B	25K	73-77	550	64 320 (141,800)	7.65 (10.0)	29 330 (64,660)	— —	— —	1930 (6'4")	4.34 (14'3")	40.2 (25.0)	43.6 (27.1)	
992C	42X	77-81	690	85 640 (188,800)	9.6 (12.5)	66 240 (146,030)	4.55 (14'11")	533 (21)	2310 (7'7")	4.17 (13'8")	21.1 (13.1)	23.3 (14.5)	3412 PCT Engine Z Bar Linkage
992C	49Z	81-92	690	88 430 (194,950)	10.4 (13.5)	66 285 (146,132)	4.50 (14'9")	544 (21)	2310 (7'7")	4.17 (13'8")	21.0 (13.0)	22.9 (14.2)	3412 DIT Engine
992D	7MJ	92-97	710	88 690 (195,125)	10.7 (14.0)	62 670 (137,870)	4.50 (14'9")	544 (21)	2300 (7'7")	4.17 (13'8")	21.0 (13.0)	22.9 (14.2)	
992G	7HR	98-00	800	91 540 (201,810)	11.5-12.3 (15-16)	62 650 (137,840)	4.50 (14'9")	691 (27.2)	2300 (7'7")	4.60 (15'3")	20.2 (12.5)	22.7 (14.1)	6 Bar Linkage "G" Series
992K	H4C	07-11	801	97 294 (214,535)	10.7-12.3 (14-16)	584.66 (128,917)	— —	682 (26)	9313 (30'6")	4480 (14'8")	20.6 (12.8)	22.4 (13.9)	10.7 m ³ /14 yd ³ Bucket
993K	Z9K	07-12	945	133 637 (294,800)	12.8-14.5 (16.7-19)	72 347 (159,500)	4.93 (16'2")	783 (30.8)	9313 (30'7")	4849 (15'11")	20.1 (22.1)	12.5 (13.7)	12.8 m ³ /16.7 yd ³ Bucket
994	9YF	90-98	1250	177 000 (390,300)	10.3 (13.4)	103 420 (228,000)	5.20 (17'1")	662 (26)	2692 (8'10")	6.20 (20'4")	24.7 (15.0)	26.6 (16.5)	
994D	3TZ	98-05	1250	191 200 (420,640)	17.0 (22.5)	96 939 (213,265)	5.4 (17'8")	676 (26)	2157 (7'1")	5698 (18'8")	24.1 (15.0)	26.6 (16.5)	Standard lift
994H	442 DWC	95-14	1577	195 434 (429,955)	18.0 (23.5)	104 082 (229,305)	5.4 (17'8")	811 (32)	2721 (8'11")	6002 (19'8")	24 (14.9)	25.6 (15.9)	High lift



TRACK LOADERS

Model	Product Ident. No. Prefix	Years Built	Flywheel Horsepower	Approx. Operating Weight kg (lb)	Rated Capacity m ³ (yd ³)	Dimensions			Remarks
						Length** m (ft)	Width m (ft)	Height m (ft)	
931	78U	72-79	62	6940 (15,300)	0.77 (1.0)	2.74 (9'0")	1.78 (5'10")	1.96 (6'5")	
931 LGP	10N	75-79	62	7498 (16,530)	1.15 (1.5)	2.74 (9'0")	2.29 (7'6")	1.98 (6'6")	
931B	29Y	79-88	65	7362 (16,230)	0.8 (1.0)	4.13 (13'9")	1.84 (6'0.5")	2.68 (8'10")	
931B LGP	30Y	79-88	65	8089 (17,834)	0.8 (1.0)	3.84 (12'7")	2.41 (7'11")	2.68 (8'10")	
931C	2BJ1		67	7595 (16,743)	0.77 (1.0)	2.74 (9'0")	1.78 (5'10")	2.68 (8'10")	
931C LGP	7HF 6RF1		67	8170 (18,012)	0.77 (1.0)	2.74 (9'0")	1.78 (5'10")	2.68 (8'10")	
931C Series II	8AF 9AG 6AJ	90-93	70	8047 (17,742)	0.83 (1.08)	4.14 (13'1")	1.97 (6'5")	2.68 (8'10")	
933C	11A	55-58	50	7030 (15,500)	0.77 (1.0)	4.22 (13'10")	1.77 (5'10")	1.91 (6'4")	Integral loader
933E	11A	58-65	50	7640 (16,850)	0.77 (1.0)	4.22 (13'10")	1.77 (5'10")	1.40 (6'3")	Integral loader
933G	42A	65-68	60	7900 (17,500)	0.86 (1.125)	4.31 (14'2")	1.77 (5'10")	2.15 (7'1")	Patented Sealed Track
935B	30F	87-88	75	7899 (17,414)	1.0 (1.25)	4.19 (13'9")	1.96 (6'5")	2.68 (8'10")	
935C	8CF		78	8205 (18,089)	1.0 (1.3)	4.19 (13'9")	1.96 (6'5")	2.68 (8'10")	
935C Series II	SDJ	90-93	80	8759 (19,311)	1.0 (1.3)	4.37 (14'4")	1.97 (6'5")	2.68 (8'10")	
939C	6DS	96-01	90	9578 (21,072)	1.2 (1.5)	4.36 (14'4")	1.96 (6'5")	2.77 (9'1")	
941	80H	68-72	70	8900 (19,700)	0.96 (1.25)	4.50 (14'10")	1.86 (6'1")	2.75 (9'0")*	Electric Start
941B	80H	68-81	80	11 294 (24,900)	1.15 (1.5)	4.50 (14'10")	1.98 (6'6")	2.75 (9'0")*	HP Increase, Hydraulic Track Adjusters
943	31Y	80-85	80	11 750 (25,900)	1.15 (1.5)	5.426 (17'10")	2.21 (8'7")	3.02 (9'11")	Hydrostatic drive
943	19Z	80-92	80	11 750 (25,900)	1.15 (1.5)	5.426 (17'10")	2.21 (8'7")	3.02 (9'11")	Hydrostatic drive made in France

*Height to top of stack. Others to top of seat back.

**Overall length to tip of smallest General Purpose bucket.

Track Loaders (cont'd)

Model	Product Ident. No. Prefix	Years Built	Flywheel Horsepower	Approx. Operating Weight kg (lb)	Rated Capacity m ³ (yd ³)	Dimensions			Remarks
						Length** m (ft)	Width m (ft)	Height m (ft)	
951B	79H	67-71	85	10 025 (22,100)	1.14 (1.5)	4.70 (15'6")	1.98 (6'6")	2.75 (9'0")*	Pedal Steering HP Increase, Sealed & Lubricated Track
951C	86J	71-81	95	12 338 (27,200)	1.34 (1.75)	4.77 (15'8")	1.98 (6'6")	2.75 (9'0")*	
953	5Z	81-85	110	14 050 (31,000)	1.5 (2.0)	5.87 (19'3")	2.38 (7'10")	3.08 (10'1")	Hydrostatic drive
953	20Z	81-92	110	14 050 (31,000)	1.5 (2.0)	5.87 (19'3")	2.38 (7'10")	3.08 (10'1")	Hydrostatic drive
953	76Y	81-85	110	13 800 (30,500)	1.5 (2.0)	5.87 (19'3")	2.38 (7'10")	3.08 (10'1")	Hydrostatic drive
953	77Y	81-85	110	13 800 (30,500)	1.5 (2.0)	5.87 (19'3")	2.38 (7'10")	3.08 (10'1")	Hydrostatic drive
953B	5MK	92-96	120	14 400 (31,800)	1.75 (2.25)	4.23 (13'4")	2.38 (7'10")	3.08 (10'1")	Hydrostatic drive
953C	2ZN	96-03	121	14 680 (32,360)	2.3 (3.0)	4.35 (14'3")	2.30 (7'7")	3.08 (10'1")	SystemOne U/C
953C	BBX	03-07	128	15 145 (33,389)	1.75 (2.25)	4.35 (14'3")	2.30 (7'7")	3.16 (10'4")	
HT4	7U	50-55	54	2607 (5748)	0.96 (1.25)	4.32 (14'2")	2.03 (6'8")	1.83 (6'0")	Integral loader
955C	12A	55-60	70	9590 (21,145)	1.15 (1.5)	4.60 (15'2")	2.03 (6'8")	2.08 (6'11")	
955E	12A	58-60	70	10 160 (22,400)	1.15 (1.5)	4.60 (15'2")	2.03 (6'8")	2.09 (6'11")	Improved undercarriage
955H	60A	60-66	100	11 320 (24,950)	1.34 (1.75)	4.79 (15'9")	1.90 (6'3")	2.65 (8'8")*	Power shift, Turbo, oil cooled brakes
955K	61H	66-71	115	12 700 (28,000)	1.34 (1.75)	5.00 (16'6")	2.06 (6'9")	2.80 (9'3")*	Horsepower and bucket capacity increase
955L	85J	71-75	130	15 330 (33,800)	1.53 (2.0)	5.30 (16'1")	2.18 (7'2")	2.95 (9'8")*	ROPS Cab, Sealed & Lubricated Track
955L	13X	75-81	130	15 853 (34,950)	1.72 (2.25)	5.26 (17'3")	2.18 (7'2")	2.95 (9'8")	

*Height to top of stack. Others to top of seat back.

**Overall length to tip of smallest General Purpose bucket.

Track Loaders (cont'd)

Model	Product Ident. No. Prefix	Years Built	Flywheel Horsepower	Approx. Operating Weight kg (lb)	Rated Capacity m ³ (yd ³)	Dimensions			Remarks
						Length** m (ft)	Width m (ft)	Height m (ft)	
963	6Z	81-85	150	18 250 (40,250)	2.0 (2.6)	6.35 (20'10")	2.50 (8'2")	3.30 (10'10")	Hydrostatic drive
963	11Z	81-85	150	18 370 (40,490)	2.0 (2.6)	6.35 (20'10")	2.50 (8'2")	3.30 (10'10")	Hydrostatic drive
963	18Z	82-86	150	18 250 (40,250)	2.0 (2.6)	6.35 (20'10")	2.50 (8'2")	3.30 (10'10")	Hydrostatic drive made in France
963	21Z	82-95	150	18 370 (40,490)	2.0 (2.6)	6.35 (20'10")	2.50 (8'2")	3.30 (10'10")	Hydrostatic drive made in France
963B	9BL	95-99	160	19 620 (43,270)	2.45 (3.2)	6.60 (21'8")	2.50 (8'2")	3.31 (10'10")	3116 engine
963C	2DS	99-03	160	19 020 (41,940)	1.75 (2.25)	4.61 (15'2")	2.40 (7'11")	3.32 (10'11")	
963C	BBD	03-07	158	19 589 (43,096)	2.45 (3.2)	4.61 (15'2")	2.40 (7'11")	3.39 (11'2")	SystemOne™ U/C
973	86G	81-00	210	25 040 (55,200)	3.2 (4.2)	7.12 (23'4")	2.85 (9'4")	3.42 (11'3")	
973C	3RZ	99-01	210	27 006 (59,548)	3.2 (4.19)	7.36 (24'2")	2.58 (8'6")	3.50 (11'6")	
973C	BCP	01-05	230	27 006 (59,548)	3.2 (4.19)	7.36 (24'2")	2.58 (8'6")	3.50 (11'6")	
No. 6	10A	53-55	80	13 229 (29,165)	1.5 (2.0)	4.90 (16'1")	2.44 (8'1")	2.11 (6'11")	
977D	20A	55-60	100	14 430 (31,795)	1.72 (2.25)	5.19 (18'0")	2.44 (8'0")	2.22 (7'4")	
977E	20A	58-60	100	15 850 (34,910)	1.72 (2.25)	5.19 (18'0")	2.44 (8'0")	2.29 (7'7")	Improved undercarriage
977H	53A	60-66	150	17 000 (37,500)	1.90 (2.5)	5.28 (17'4")	2.44 (8'0")	2.29 (7'7")	Power shift, Turbo, oil cooled brakes
977K	46H	66-78	170	19 100 (42,000)	1.90 (2.5)	5.50 (18'0")	2.38 (7'10")	3.05 (10'0")*	Walk-through compartment, longer roller frame
977L	14X	78-82	190	21 780 (48,010)	2.10 (2.75)	5.59 (18'4")	2.38 (7'10")	3.32 (10'11")*	Horsepower and bucket capacity increase
983	38K	69-78	275	34 460 (75,980)	3.82 (5.0)	6.78 (22'3")	2.90 (9'6")	2.79 (11'10")*	
983B	58X	78-82	275	35 620 (78,530)	3.82 (5.0)	6.78 (22'3")	2.90 (9'6")	3.68 (12'1")*	DI engine

*Height to top of stack. Others to top of seat back.

**Overall length to tip of smallest General Purpose bucket.



INTEGRATED TOOLCARRIERS

Model	Product Ident. No. Prefix	Years Built	Flywheel Horse-power	Approx. Operating Weight kg (lb)	Rated Capacity m ³ (yd ³)	Breakout Force kg (lb)	Width Over Tires m (ft)	Ground Clearance mm (in)	Max. Reach at Max. Height mm (in)	Dump Clearance at Max. Height m (ft)	Maximum Speeds km/h (mph)		Remarks
											Fwd.	Rev.	
IT12	2YC	84-89	65	7393 (16,299)	1.0 (1.25)	7193 (15,858)	2.3 (7'8")	405 (15.9)	873 (34)	2.84 (9'4")	23.6 (14.6)	24.9 (15.4)	
IT12B	1KF	89-93	78	7950 (17,530)	1.2 (1.6)	6160 (13,583)	2.15 (7'1")	343 (13.5)	958 (37.7)	2.69 (8'10")	34.0 (21.1)	22.4 (13.9)	
IT12F	1KF	93-95	80	7893 (17,401)	1.3 (1.7)	6479 (14,247)	2.15 (7'1")	365 (14)	917 (37)	2.74 (8'11.8")	34.0 (21.1)	22.4 (13.9)	
IT14B	3NJ	89-93	85	8333 (18,374)	1.2 (1.6)	7525 (16,593)	2.15 (7'1")	344 (13.6)	958 (37.7)	2.70 (8'11")	37.3 (23.2)	24.4 (15.2)	
IT14F	4EL	93-95	85	7999 (17,635)	1.3 (1.7)	7170 (15,808)	2.15 (7'1")	365 (14)	918 (37)	2.74 (9'0")	37.3 (23.2)	24.4 (15.2)	
IT14G	1WN 8ZM FWL KZN	95-14	95	8450 (18,632)	1.2-1.4 (1.6-1.8)	7700 (17,342)	2.258 (7'5")	456 (16.3)	787 (31)	2.921 (9'7")	32.0 (20.0)	32.0 (20.0)	C4.4 ACERT Engine IT Linkage HystatTransmission
IT14G2	ERP	12-14	95	8450 (18,632)	1.2-1.4 (1.6-1.8)	7700 (17,342)	2.258 (7'5")	456 (16.3)	787 (31)	2.921 (9'7")	32.0 (20.0)	32.0 (20.0)	C4.4 ACERT Engine IT Linkage HystatTransmission
IT18	9NB	84-86	85	8660 (19,092)	1.2 (1.5)	9105 (20,108)	2.4 (7'10")	285 (11.2)	990 (39)	2.84 (9'4")	25.0 (15.5)	25.0 (15.5)	
IT18B	4ZD	86-92	95	9770 (21,540)	1.3 (1.75)	10 500 (21,350)	2.28 (7'6")	324 (12.8)	993 (39)	2.89 (9'6")	26.4 (16.4)	27.7 (17.2)	
IT18F	6ZF	92-94	105	9959 (21,960)	1.6 (2.0)	8880 (19,580)	2.33 (7'8")	321 (13)	1089 (43)	2.75 (9'0")	37.0 (23.0)	24.5 (15.2)	
IT24F	4NN	94-99	105	9989 (20,022)	1.7 (2.5)	8782 (19,361)	2.33 (7'6")	321 (12.6)	1088 (42)	2.75 (9'0")	38.0 (23.6)	23.4 (14.8)	
IT28	2KC	84-86	105	9560 (21,076)	1.5 (2.0)	9505 (20,955)	2.4 (7'10")	285 (11.2)	1044 (41)	2.82 (9'3")	30.8 (18.8)	32.3 (20.0)	
IT28B	1HF	86-93	110	10 580 (23,325)	1.7 (2.25)	10 456 (23,050)	2.32 (7'7")	324 (12.8)	1091 (43)	2.73 (8'11")	34.4 (21.4)	37.2 (23.1)	
IT28F	3CL	93-96	125	11 430 (25,200)	2.0 (2.6)	9840 (21,700)	2.43 (8'0")	317 (12)	1093 (43)	2.72 (8'11")	35.4 (21.9)	21.4 (13.5)	
IT28G	DBT	02-04	146	12 640 (27,860)	2.0 (2.6)	10 631 (23,437)	2.54 (8'4")	407 (16)	958 (38)	2.97 (9'9")	37.7 (23.4)	25.8 (16.0)	
IT28G	EWF	02-05	131	11 250 (24,802)	2.0 (2.6)	11 723 (25,849)	2.44 (8'0")	408 (16)	1455 (57)	2.879 (9'5")	37.7 (23.4)	25.8 (16.0)	
IT28G	WAC	02-05	131	11 250 (24,802)	2.0 (2.6)	11 723 (25,849)	2.44 (8'0")	408 (16)	1455 (57)	2.879 (9'5")	37.7 (23.4)	25.8 (16.0)	
IT38G	CSX	02-07	160	14 583 (32,156)	2.8 (3.66)	11 216 (24,729)	2.6 (102)	400 (16)	1224 (48)	2.733 (108)	38.8 (24.1)	23.3 (14.5)	
Series II IT38H	JNJ	07-12	200	16 000 (35,274)	3.0 (3.92)	12 797 (28,214)	2.67 (8'9")	400 (16)	1152 (45)	2.81 (9'2")	43.2 (26.8)	25.5 (15.8)	
950F CT	5SK	94-98	170	16 600 (36,580)	3.1 (4.0)	13 590 (29,950)	2.87 (9'5")	460 (18)	1714 (68)	2.845 (9'4")	38.7 (24.0)	42.7 (26.5)	



TELEHANDLERS

Model	Product Ident. No. Prefix	Years Built	Flywheel Horsepower kW (hp)	Operating Weight kg (lb)	Engine	Maximum Lift Height m (ft/in)	Maximum Reach m (ft/in)	Maximum Lift Capacity kg (lb)
TH62	4TM	00-02	72 (105)	6840 (15,080)	Cat 3054T	7.6 (25'0")	4.2 (13'9")	2725 (6000)
TH63	5WM	00-02	72 (105)	9260 (20,420)	Cat 3054T	12.5 (41'0")	8.1 (26'7")	3000 (6615)
TH82	3JN	00-02	72 (105)	7470 (16,470)	Cat 3054T	7.6 (25'0")	4.2 (13'9")	3635 (8000)
TH83	3RN	00-02	72 (105)	10 000 (22,050)	Cat 3054T	12.5 (41'0")	8.2 (27'0")	3635 (8000)
TH103	3PN	00-02	72 (105)	12 500 (27,500)	Cat 3054T	13.5 (44'0")	8.8 (28'9")	4536 (10,000)
TH210	MHT	03-06	60 (80)	5000 (11,023)	Cat 3054B DI	5.18 (17'0")	2.8 (9'2")	2200 (4840)
TH215	MHS	03-06	60 (80)	5500 (12,100)	Cat 3054B DI	5.54 (18'2")	3.1 (10'2")	2500 (5500)
TH220B	SLA/TBF	03-07	74.5 (100)	6700 (14,774)	Cat 3054E	6.1 (20'0")	3.3 (10'9")	3500 (7718)
TH330B	SLB/TBG	03-07	74.5 (100)	7200 (15,876)	Cat 3054E	7.2 (23'7")	3.8 (12'6")	3600 (7938)
TH340B	SLC	03-06	74.5 (99.9)	7700 (17,000)	Cat 3054E	9.0 (29'6")	6.5 (21'4")	3000 (6600)
TH350B	SLD	03-06	74.5 (99.9)	8480 (18,100)	Cat 3054E	11.0 (36'0")	7.4 (24'0")	3000 (6600)
TH360B	SLE/TBH	03-07	74.5 (100)	9970 (21,984)	Cat 3054E	13.5 (44'3")	9.2 (30'2")	3500 (7718)
TH460B	SLF	03-06	74.5 (99.9)	10 500 (21,600)	Cat 3054E	13.5 (44'4")	9.2 (30'0")	4000 (8800)
TH560B	SLG/TBP	03-07	74.5 (99.9)	12 000 (26,500)	Cat 3054E	13.5 (44'0")	9.2 (30'0")	5000 (11,000)
TH580B	SLH/TBJ	03-07	74.5 (99.9)	13 670 (30,100)	Cat 3054E	17 (56'0")	12.7 (42'0")	5000 (11,000)

Former Models

Paving Products

- Cold Planers
- Reclaimers & Stabilizers



PAVING PRODUCTS – COLD PLANERS

Model	Product Ident. No. Prefix	Years Built	kW Flywheel (Horsepower)	Approximate Operating Weight kg (lb)	General Dimensions (Shipping)		
					Height mm (ft)	Length mm (ft)	Width mm (ft)
PR-75		85-92	52 (77)	5900 (13,000)	2690 (8'10")	3050 (10'0")	2130 (7'0")
PR-105		85-92	67 (90)	7711 (17,000)	2921 (9'7")	3581 (11'9")	2515 (8'3")
PR-275	6RC	—	201 (270)	17 237 (38,000)	2896 (9'6")	5740 (18'10")	2438 (8'0")
PR-450		85-92	336 (450)	28 308 (58,000)	4270 (14'0")	13 280 (43'8")	2870 (9'5")
PR-450C		92-97	336 (450)	28 308 (58,000)	3810 (12'6")	13 200 (43'6")	2490 (8'2")
PR-750B		85-92	559 (750)	42 638 (94,000)	3734 (12'3")	16 500 (54'0")	3575 (11'9")
PR-1000			Cutter 559 (750) Track 186 (250)	46 780 (103,130)	3810 (12'6")	16 590 (54'5")	4877 (16'0")
PM-465	5ZS	97-03	353 (473)	14 333 (31,600)	2820 (9'3")	13 716 (45'0")	2489 (8'2")
PM-565		xx-05	466 (625)	38 595 (85,100)	5040 (16'6")	15 100 (49'5")	2790 (9'2")
PM201		05-14	485 (650)	39 165 (86,360)	5040 (16'6")	15 100 (49'5")	2810 (9'2")



PAVING PRODUCTS – RECLAIMERS & STABILIZERS

Model	Product Ident. No. Prefix	Years Built	kW Flywheel (Horsepower)	Approximate Operating Weight kg (lb)	General Dimensions (Shipping)		
					Height mm (ft)	Length mm (ft)	Width mm (ft)
SS-250	6DD	85-96	250 (335)	13 300 (29,300)	3220 (10'7")	8780 (28'10")	2900 (9'7")
SS-250B	5GR	96-01	250 (335)	14 340 (31,600)	2600 (8'6")	8560 (28'1")	2900 (9'6")
RR-250	6ED	85-96	250 (335)	17 876 (39,300)	3220 (10'7")	8780 (28'10")	2900 (9'7")
RR-250B	3RR	96-01	250 (335)	19 260 (42,470)	2600 (8'6")	8560 (28'1")	2900 (9'6")
RM-250C			250 (335)	16 780 (37,000)	3220 (10'7")	8780 (28'10")	2921 (9'7")
RM-350	5FK	92-97	321 (430)	21 440 (47,200)	3404 (11'2")	9577 (31'5")	2997 (9'10")
SM-350	1RM	92-97	321 (430)	18 440 (40,600)	3404 (11'2")	9577 (31'5")	2997 (9'10")
RM-350B			373 (500)	24 040 (53,000)	3404 (11'2")	9980 (32'9")	2997 (9'10")
RM500		06-14	403 (540)	28 145 (62,060)	3480 (11'4")	9680 (31'8")	2980 (9'7")

- Paving Products
- Unitized Venturi-Mixers & Unitized Drum-Mixers
- Portable Venturi-Mixers

Former Models



PAVING PRODUCTS – UNITIZED VENTURI-MIXERS & UNITIZED DRUM-MIXERS

Model	Drum Dimensions		Gross Volume m ³ (ft ³)	Performance	
	Diameter mm (ft)	Length m (ft)		Production Range/hr. metric tons (tons)	Air Flow m ³ /min (ft ³ /min)
UVM-500	1829/1524 (6'0"/5'0")	7.9 (26'0")	14.17 (500)	68-109 (75-120)	300-481 (10,600-17,000)
UDM-600	1829 (6'0")	6.7 (22'0")	17.00 (600)	82 (89)	354.25 (12,500)
UDM-900	2134/1829 (7'0"/6'0")	9.1 (30'0")	25.48 (900)	68-227 (75-250)	311-793 (11,000-28,000)
UVM-1000	2134 (7'0")	9.754 (32'0")	28.34 (1000)	82-272 (90-300)	425-1076 (15,000-38,000)
UVM-1400	2286 (7'6")	10.973 (36'0")	39.64 (1400)	100-358 (110-395)	481-1274 (17,000-45,000)
UVM-1700	2591 (8'6")	11.582 (38'0")	48.14 (1700)	122-480 (135-450)	651-1614 (23,000-57,000)



PAVING PRODUCTS – PORTABLE VENTURI-MIXERS

26

Model	Drum Dimensions		Gross Volume m ³ (ft ³)	Performance	
	Diameter mm (ft)	Length m (ft)		Production Range/hr. metric tons (tons)	Air Flow m ³ /min (ft ³ /min)
PVM-1100	2134 (7'0")	10.97 (36'0")	31.15 (1100)	82-295 (90-325)	425-1133 (15,000-40,000)
PVM-1500	2286 (7'6")	12.19 (40'0")	42.48 (1500)	100-363 (110-400)	510-1274 (18,000-45,000)
PVM-2000	2591 (8'6")	12.80 (42'0")	56.64 (2000)	122-454 (135-500)	680-1699 (24,000-60,000)
PVM-2500	2896 (9'6")	12.80 (42'0")	70.79 (2500)	136-499 (150-550)	793-2110 (28,000-74,500)
PVM-2900	3048 (10'0")	13.41 (44'0")	82.12 (2900)	168-553 (185-610)	906-2265 (32,000-80,000)
PVM-3300	3200 (10'6")	13.41 (44'0")	93.45 (3300)	181-612 (200-675)	991-2464 (35,000-87,000)

Former Models

Paving Products

- Stationary Venturi-Mixers
- SlipForm Pavers



PAVING PRODUCTS – STATIONARY VENTURI-MIXERS

Model	Drum Dimensions			Performance	
	Diameter mm (ft)	Length m (ft)	Gross Volume m ³ (ft ³)	Production Range/hr. metric tons (tons)	Air Flow m ³ /min (ft ³ /min)
SVM-1100	2134 (7'0")	10.97 (36'0")	31.15 (1100)	82-295 (90-325)	425-1133 (15,000-40,000)
SVM-1500	2286 (7'6")	12.19 (40'0")	42.48 (1500)	100-363 (110-400)	510-1274 (18,000-45,000)
SVM-2000	2591 (8'6")	12.80 (42'0")	56.64 (2000)	122-454 (135-500)	680-1699 (24,000-60,000)
SVM-2500	2896 (9'6")	12.80 (42'0")	70.79 (2500)	136-499 (150-550)	793-2110 (28,000-74,500)
SVM-2900	3048 (10'0")	13.41 (44'0")	82.12 (2900)	168-553 (185-610)	906-2265 (32,000-80,000)
SVM-3600	3200 (10'6")	14.63 (48'0")	101.94 (3600)	190-623 (210-685)	1020-2565 (36,000-90,000)



PAVING PRODUCTS – SLIPFORM PAVERS

Model	Product Ident. No. Prefix	Years Built	Flywheel Horsepower	Approx. Operating Weight kg (lb)	Standard Paving Width m (ft)	Shipping Dimensions (Min.)			Remarks
						Length m (ft)	Width m (ft)	Height m (ft)	
SF-175	5ZC	—	142	9072 (20,000)	2.1 (7'0")	6.6 (21'6")	2.4 (8'0")	2.8 (9'4")	
SF-250	6XC	—	208	24 494 (54,000)	3.6 (12'0")	3.0 (10'0")	3.7 (12'0")		
SF-250B	—	—	250	27 216 (60,000)	3.7-7.3 (12'0"-24'0")	1.5 (5'0")	3.66 (12'0")	3.20 (10'6")	
SF-350	—	—	290	40 824 (90,000)	3.6-7.3 (12'0"-24'0")	1.04 (3'5")	3.0 (10'0")	2.9 (9'8")	
SF-450	7GC	73-83	400	43 546* (96,000) 53 525** (118,000)	3.66-7.62 (12'0"-25'0")	9.35 (30'8")	3.05 (10'0")	2.90 (9'6")	
SF-500	8DC	—	400	52 164 (115,000)	7.6 (25'0")	8.9 (29'2½")	3.0 (10'0")	3.0*** (10'2")	
SF-550	5PD	—	400	52 164 (115,000)	5.5-8.5 (18'0"-28'0")	7.0 (23'0")	3.7 (12'0")	2.9 (9'8")	

*Weight of 7.62 m (25'0") machine.

**Weight of 11.58 m (38'0") machine.

***Machine legs and track shipped separately.

- Placer-Spreader-Trimmer
- Belt Placer
- Tube Finisher
- Texturing/Curing
- Trimmer-Reclaimer

Former Models



PAVING PRODUCTS – PLACER-SPREADER-TRIMMER, BELT PLACER

Model	Product Ident. No. Prefix	Years Built	Flywheel Horsepower	Approximate Operating Weight kg (lb)	General Dimensions		
					Height m (ft)	Length m (ft)	Width m (ft)
PST-300	8EC	—	250	38 193 (84,200)	2.64 (8'8")	10.57 (34'8")	9.02 (29'7")
BP-100	1EF	—	102	11 340 (22,000)	3.27 (10'9")	2.49 (8'2")	2.49 (8'2")



PAVING PRODUCTS – TUBE FINISHER, TEXTURING/CURING

Model	Product Ident. No. Prefix	Years Built	Flywheel Horsepower	Approximate Operating Weight kg (lb)	General Dimensions (Shipping)		
					Height mm (ft)	Length mm (ft)	Width mm (ft)
TF-250	6YC	—	52	5897 (13,000)	2489 (8'2")	8484 (27'10")	2438 (8'0")
TC-250	7HC	—	56	5897 (13,000)	2489 (8'2")	8484 (27'10")	2438 (8'0")



PAVING PRODUCTS – TRIMMER-RECLAIMER

Model	Product Ident. No. Prefix	Years Built	Flywheel Horsepower	Approximate Operating Weight kg (lb)	General Dimensions (Shipping)		
					Height mm (ft)	Length m (ft)	Width mm (ft)
TR-225B	6WC	—	250	21 319 (47,000)	3200 (10'6")	13.9 (45'9.5")	2896 (9'6")
TR-500	8CC	—	375	46 267 (102,000)	3099 (10'2")	8.9 (29'2¾")	3048 (10'0")

Former Models

Paving Products

- Asphalt Pavers
- Windrow Elevators



PAVING PRODUCTS – ASPHALT PAVERS & WINDROW ELEVATORS

Model	Product Ident. No. Prefix	Years Built	Flywheel kW (hp)	Approx. Op. Weight kg (lb)	Drive	Screed Width mm (ft)	Hopper Capacity m ³ (ft ³)	Maximum Op. Speed m/min (ft/min)
AP-200	2NK	86-01	26 (35)	4080 (9000)	Track	2743 (9'0")	5.4 t (6T)	53.6 (176)
AP-200	6AD	85-91	26 (35)	4080 (9000)	Track	2743 (9'0")	5.4 t (6T)	0-54 (0-177)
AP-650B		-08	97 (130)	13 917 (30,655)		2400 (8'0")	5 t (177T)	67 (220)
AP755	B2T - B3T	06-12	149 (202)	21 600 (47,620)	Track	9100 (29'10")	7.0 (247)	26 (85)
AP-800	1BF	86-89	76 (102)	11 903 (26,350)	Wheel	2438 (8'0")	5.8 (206)	95 (312)
AB-800B	1BF	89-93	76 (102)	11 903 (26,350)	Wheel	2438 (8'0")	5.8 (206)	95 (312)
AP-800C			80 (107)	12 115 (26,700)	Wheel	2438 (8'0")	5.5 (195)	76 (250)
AP-800D			80 (107)	12 115 (26,700)	Wheel	2400 (8'0")	5.5 (195)	76 (250)
AP-900		-06	114 (153)	14 445 (31,850)	Wheel	3000 (10'0")	6.1 (215)	122 (400)
AP-1000B		-05	130 (174)	15 490 (34,150)	Wheel	3000 (10'0")	6.1 (215)	114 (374)
AP-1000D	N/A	05-11	167 (224)	17 851 (39,320)	Wheel	7320 (24'2")	6.1 (215)	91 (300)
AP-1050	1JG	89-96	116 (155)	14 878 (32,800)	Track	3048 (10'0")	6.2 (215)	57 (186)
AP-1050B			130 (174)	16 015 (35,300)	Track	3048 (10'0")	6.1 (215)	61 (200)
AP-1055B			130 (174)	16 556 (36,500)	Track	3048 (10'0")	6.1 (215)	61 (200)
AP-1055D	N/A	05-11	167 (224)	20 330 (44,780)	Track	7320 (24'2")	6.1 (215)	78 (225)
AP-1200	2JD	85-89	108 (145)	13 608 (30,000)	Wheel	3048 (10'0")	6.2 (220)	21.4 (13.3)
WE601B	TEC	85-91	78 (102)	3856 (8500)	N/A	1524 (5'0")	N/A	N/A
BG-200A	N/A	89-91	35 (47)	6750 (14,900)	Wheel	1803 (5'11")	3.26 (116)	56 (180)
BG-210	N/A	90-91	79 (106)	10 192 (22,500)	Wheel	2438 (8'0")	4.76 (170)	84 (275)
BG-210B	N/A	91-01	80 (107)	11 793 (26,000)	Wheel	2438 (8'0")	4.8 (170)	0-21.7 (0-13.5)
BG-220	N/A	84-87	58 (78)	9752 (21,500)	Wheel	2438 (8'0")	3.7 (130)	88 (289)
BG-220B	4ZM	91-94	80 (108)	12 483 (27,525)	Wheel	2438 (8'0")	4.3 (155)	88 (289)

Paving Products — Asphalt Pavers & Windrow Elevators (cont'd)

Model	Product Ident. No. Prefix	Years Built	Flywheel kW (hp)	Approx. Op. Weight kg (lb)	Drive	Screed Width mm (ft)	Hopper Capacity m ³ (ft ³)	Maximum Op. Speed m/min (ft/min)
BG-225	N/A	84-87	58 (78)	11 339 (25,000)	Track	2438 (8'0")	3.7 (130)	58 (188)
BG-225B	N/A		118 (158)	16 400 (36,200)	Track	2438 (8'0")	4.3 (155)	57 (189)
BG-225C			97 (130)	13 917 (30,655)	Track	2400 (8'0")	5 (177)	67 (220)
BG-230			80 (107)	12 111 (26,700)	Wheel	2438 (8'0")	5.5 (195)	76 (250)
BG500E		10-13	106 (142)	15 520 (34,220)	Wheel	2440 (8'0")	6.2 (219)	61 (200)
BG600D		08-13	129 (174)	17 122 (37,747)	Wheel	2440 (8'0")	6.5 (230)	61 (200)
BG-230D			97 (130)	13 307 (29,310)	Wheel	2400 (8'0")	5.5 (195)	76 (250)
BG-240	N/A	85-86	72 (96)	13 154 (29,000)	Wheel	3048 (10'0")	3.7 (130)	81 (265)
BG-240B	7RL	87-99	86 (115)	15 200 (33,500)	Wheel	3048 (10'0")	6.5 (230)	81 (265)
BG-245	N/A	85-87	72 (96)	14 514 (32,000)	Track	3048 (10'0")	5.8 (206)	58 (189)
BG-245B	3XL	87-96	116 (155)	16 080 (35,450)	Track	3048 (10'0")	5.8 (206)	55 (182)
BG-245C	N/A		130 (174)	16 015 (35,300)	Track	3048 (10'0")	6.1 (215)	60.1 (200)
BG-2455C	N/A		130 (174)	16 555 (36,500)	Track	3048 (10'0")	6.1 (215)	61 (200)
BG555E		10-13	106 (142)	16 240 (35,810)	Track	2440 (8'0")	6.2 (219)	61 (200)
BG655D		08-13	129 (174)	18 250 (40,234)	Track	2440 (8'0")	6.5 (230)	61 (200)
BG1055E		11-13	168 (225)	20 076 (44,167)	Track	3000 (10'0")	7.1 (251)	61 (200)
BG-2455D	N/A	05-11	167 (224)	20 330 (44,780)	Track	7320 (24'2")	6.1 (215)	78 (225)
AP600D		08-14	129 (174)	17 122 (37,749)	Wheel	2440 (8'0")	6.5 (230)	61 (200)
AP655D		07-14	129 (174)	18 245 (40,225)	Track	2440 (8'0")	6.5 (230)	61 (200)

Former Models

Paving Products

- Asphalt Pavers
- Windrow Elevators

Paving Products — Asphalt Pavers & Windrow Elevators (cont'd)

Model	Product Ident. No. Prefix	Years Built	Flywheel kW (hp)	Approx. Op. Weight kg (lb)	Drive	Screed Width mm (ft)	Hopper Capacity m ³ (ft ³)	Maximum Op. Speed m/min (ft/min)
BG-260	N/A	85-87	106 (142)	14 514 (32,000)	Wheel	3048 (10'0")	5.8 (206)	77 (253)
BG-260B	N/A		116 (155)	14 740 (32,500)	Wheel	3048 (10'0")	5.8 (206)	90 (296)
BG1000E		11-13	168 (225)	18 427 (40,539)	Wheel	3000 (10'0")	7.1 (251)	61 (200)
BG-260D	N/A	05-11	167 (224)	17 851 (39,320)	Wheel	7320 (24'2")	6.1 (215)	91 (300)
BG-265	N/A	85-87	106 (142)	16 782 (37,000)	Track	3048 (10'0")	5.8 (206)	50 (164)
BG-265B	7XK	87-98	145 (195)	18 380 (40,570)	Track	3048 (10'0")	5.8 (206)	50 (164)
BG-270B	N/A		145 (195)	15 510 (34,200)	Wheel	3048 (10'0")	6.5 (230)	90 (296)
BG-610	N/A	85	58 (78)	4394 (9700)	N/A	1524 (5'0")	N/A	N/A
BG-610A	N/A	86-90	58 (78)	4911 (10,840)	N/A	1524 (5'0")	N/A	N/A
BG-650	N/A		80 (107)	7984 (17 600)	N/A	N/A	N/A	N/A
BG-710	N/A		111 (149)	13 380 (29,500)	Wheel	3048 (10'0")	10.0 (80)	98 (320)
BG-730	N/A	87-02	114 (153)	14 061 (31,000)	Wheel	3048 (10'0")	10.0 (80)	0-24.1 (0-15.0)
BG-750	N/A	87-97	116 (155)	17 010 (37,500)	Wheel	4270 (14'0")	10.0 (80)	0-24.1 (0-15.0)
MTP-1260	N/A	86-90	58 (78)	4911 (10,840)	N/A	3048 (10'0")	7.7 (275)	58 (189)
MTP-1265	N/A	88-91	167 (224)	25 368 (56,000)	N/A	3048 (10'0")	11.2 (400)	50 (164)
AP300		06-14	52 (70)	7300 (16,094)	Wheel	1700 (5'7")	3.8 (134)	85 (279)
AP1000E		11-14	168 (225)	18 427 (40,539)	Wheel	3048 (10'0")	7.1 (251)	61 (200)
AP1055E		11-14	168 (225)	20 076 (44,167)	Track	3048 (10'0")	7.1 (251)	61 (200)



PAVING PRODUCTS – SINGLE DRUM VIBRATORY COMPACTORS

Model	Product Ident. No. Prefix	Years Built	Flywheel kW (hp)	Approx. Op. Weight kg (lb)	Drive	Drum Width mm (in)	Centrifugal Force kg (lb)	Maximum Op. Speed km/h (mph)
CS-323	1TM	85-95	57 (77)	4173 (9200)	Wheel/ Drum	1219 (48)	5760 (12,700)	0-10.9 (0-6.8)
CS-323C		04-10	62 (83)	4390 (9680)	Wheel/ Drum	1270 (50)	6804 (15,000)	8.9 (5.5)
CP-323	6JD	85-95	57 (77)	4218 (9300)	Wheel/ Drum	1219 (48)	5760 (12,700)	0-10.9 (0-6.8)
CP-323C		04-10	62 (83)	4745 (10,440)	Wheel/ Drum	1270 (50)	6804 (15,000)	8.9 (5.5)
CS-431	6MD	85-87	52 (70)	6110 (13,480)	Wheel	1680 (66)	7260 (16,000)	21.0 (13.0)
CS-431B	1XF	88-94	76.5 (102)	6312 (13,915)	Wheel	1680 (66)	11 235 (24,746)	8.9 (8.0)
CS-431C	9XL	94-01	78 (105)	6509 (14,349)	Wheel/ Drum	1680 (66)	13 609 (30,000)	12.8 (8.0)
CS-433	6ND	85-87	60 (80)	6720 (14,820)	Wheel/ Drum	1524 (60)	7260 (16,000)	10.0 (6.0)
CP-433	6NP	85-87	60 (80)	6750 (14,870)	Wheel/ Drum	1524 (60)	7260 (16,000)	10.0 (6.0)
CS-433B	4FK	88-94	76.5 (102)	6448 (14,215)	Wheel/ Drum	1680 (66)	11 235 (24,746)	12.8 (8.0)
CS-433C	3TM	94-01	78 (105)	6773 (14,931)	Wheel/ Drum	1680 (66)	13 609 (30,000)	12.8 (8.0)
CS-433E		04-10	75 (100)	6745 (14,875)	Wheel/ Drum	1700 (66)	13 608 (30,000)	11.5 (7.1)
CP-433B	1MG	88-94	76.5 (102)	6668 (15,225)	Wheel/ Drum	1680 (66)	11 235 (24,746)	12.8 (8.0)
CP-433C	2JM	94-01	78 (105)	7075 (15,597)	Wheel/ Drum	1680 (66)	13 609 (30,000)	12.8 (8.0)
CP-433E		04-10	75 (100)	7145 (15,750)	Wheel/ Drum	1700 (66)	13 608 (30,000)	11.5 (7.1)
CS-531	3WM	93-95	108 (145)	9310 (20,500)	Wheel	2134 (84)	22 680 (50,000)	12.8 (8.0)
CS-531C	5ZN	95-00	108 (145)	9300 (20,450)	Wheel	2134 (84)	24 091 (53,000)	12.8 (8.0)
CS-531D	3AZ 4MZ AGH	98-99 99-04 01-03	108 (145)	9650 (21,230)	Rear Wheel	2130 (84)	27 124 (60,000)	12.7 (7.8)

Paving Products — Single Drum Vibratory Compactors (cont'd)

Model	Product Ident. No. Prefix	Years Built	Flywheel kW (hp)	Approx. Op. Weight kg (lb)	Drive	Drum Width mm (in)	Centrifugal Force kg (lb)	Maximum Op. Speed km/h (mph)
CS-533	3BL	93-95	108 (145)	10 110 (22,500)	Wheel/ Drum	2134 (84)	22 680 (50,000)	12.8 (8.0)
CS-533C	2WN	95-00	108 (145)	9500 (20,900)	Wheel/ Drum	2134 (84)	24 091 (53,000)	12.8 (8.0)
CS-533D	AET	00-03	108	9960	Drum/	2130	27 124	12.7
CS54	5CZ	00-04	(145)	(21,912)	Rear Wheel	(84)	(60,000)	(7.8)
		07-13	97 (130)	10 840 (23,898)	Wheel/ Drum	2134 (84)	23 860 (52,600)	11.1 (6.9)
CP-533	3ZL	93-95	108 (145)	11 470 (25,250)	Wheel/ Drum	2134 (84)	22 680 (50,000)	12.8 (8.0)
CP-533C	3XN	95-00	108 (145)	10 180 (22,400)	Wheel/ Drum	2134 (84)	24 091 (53,000)	12.8 (8.0)
CP-533D	6AZ	01-04	108	10 240	Drum/	2130	27 124	13.2
CP54	AFC	00-03	(145)	(22,528)	Rear Wheel	(84)	(60,000)	(8.1)
		07-13	97 (130)	11 530 (25,419)	Wheel/ Drum	2134 (84)	23 860 (52,600)	11.1 (6.9)
CS-551	6ZD	85-89	115	10 428	Wheel	2130	18 150	12.1
	8AD		(155)	(22,990)		(84)	(40,000)	(7.5)
CS-553	7AD	85-89	115 (155)	10 782 (23,770)	Wheel/ Drum	2130 (84)	18 150 (40,000)	10.5 (6.5)
CP-553	7BD	85-89	115 (155)	12 247 (27,000)	Wheel/ Drum	2130 (84)	22 680 (50,000)	10.5 (6.5)
CS-563	8XF	89-95	108 (145)	11 130 (24,500)	Wheel/ Drum	2134 (84)	22 680 (50,000)	12.8 (8.0)
CS-563C	4KN	95-00	108 (145)	11 215 (24,700)	Wheel/ Drum	2134 (84)	24 091 (53,000)	12.8 (8.0)
CS-563D	9MW	98-02	108 (145)	10 875 (23,975)	Wheel/ Drum	2130 (84)	27 216 (60,000)	12.7 (7.8)
CS56		07-13	116 (156)	11 414 (25,164)	Wheel/ Drum	2134 (84)	28 712 (63,300)	11.4 (7.0)
CP-563	1YJ	89-95	108 (145)	11 580 (25,800)	Wheel/ Drum	2134 (84)	22 680 (50,000)	12.8 (8.0)
CP-563C	5JN	95-00	108 (145)	11 670 (25,700)	Wheel/ Drum	2134 (84)	24 091 (53,000)	12.8 (8.0)
CP-563D	9ZW	98-02	108 (145)	11 275 (24,856)	Wheel/ Drum	2130 (84)	27 216 (60,000)	13.2 (8.1)
CP56		07-13	116 (156)	11 361 (25,047)	Wheel/ Drum	2134 (84)	28 712 (63,300)	11.4 (7.0)

Paving Products — Single Drum Vibratory Compactors (cont'd)

Model	Product Ident. No. Prefix	Years Built	Flywheel kW (hp)	Approx. Op. Weight kg (lb)	Drive	Drum Width mm (in)	Centrifugal Force kg (lb)	Maximum Op. Speed km/h (mph)
CS-573C	6LN	95-00	108 (145)	13 800 (30,360)	Wheel/ Drum	2134 (84)	24 091 (53,000)	12.8 (8.0)
CS-573D	CMK	00-02	108 (145)	12 180 (29,060)	Wheel/ Drum	2130 (84)	27 216 (60,000)	12.7 (7.8)
CS64		07-13	116 (156)	14 238 (31,389)	Wheel/ Drum	2134 (84)	28 712 (63,300)	11.4 (7.0)
CP64		07-13	116 (156)	14 311 (31,550)	Wheel/ Drum	2134 (84)	28 712 (63,300)	11.4 (7.0)
CS-583	8YJ	91-95	108 (145)	15 040 (33,090)	Wheel/ Drum	2134 (84)	22 680 (50,000)	12.8 (8.0)
CS-583C	7MN	95-00	108 (145)	15 230 (33,500)	Wheel/ Drum	2134 (84)	24 091 (53,000)	12.8 (8.0)
CS-583D	2CZ	98-02	108 (145)	14 850 (32,740)	Wheel/ Drum	2130 (84)	31 751 (70,000)	12.7 (7.8)
CS74		07-13	116 (156)	15 455 (34,072)	Wheel/ Drum	2134 (84)	33 840 (74,600)	11.4 (7.0)
CP74		07-13	116 (156)	15 333 (33,804)	Wheel/ Drum	2134 (84)	33 840 (74,600)	11.4 (7.0)
CS-643	7FD	85-87	100 (134)	14 900 (32,855)	Wheel/ Drum	2200 (86)	16 800 (37,044)	15.5 (9.6)
CP-643	7GD	85-87	100 (134)	16 300 (35,942)	Wheel/ Drum	2200 (86)	12 600 (27,783)	15.5 (9.6)
CS76		07-13	130 (174)	16 758 (36,945)	Wheel/ Drum	2134 (84)	33 840 (74,600)	11.4 (7.0)
CP76		07-13	130 (174)	16 896 (37,249)	Wheel/ Drum	2134 (84)	33 840 (74,600)	11.4 (7.0)
CS-653	7HD	85-91	100 (134)	17 100 (37,690)	Wheel/ Drum	2200 (86)	22 230 (48,995)	15.5 (9.6)
CS76 XT		07-13	130 (174)	18 611 (41,030)	Wheel/ Drum	2134 (84)	33 840 (74,600)	11.4 (7.0)
CP-653	7JD	85-91	100 (134)	18 500 (40,774)	Wheel/ Drum	2200 (86)	22 230 (48,995)	15.5 (9.6)
TSF-54	7KD	85-88	26 (35)	2131 (4700)	Towed	1370 (54)	6810 (15,000)	Towed
TSM-54	7LD	86-88	26 (35)	2160 (4760)	Towed	1370 (54)	6810 (15,000)	Towed



PAVING PRODUCTS – DOUBLE DRUM, COMBI AND PNEUMATIC TIRE COMPACTORS

Model	Product Ident. No. Prefix	Years Built	Flywheel kW (hp)	Approx. Op. Weight kg (lb)	Drive	Drum Width mm (in)	Centrifugal Force kg (lb)	Maximum Op. Speed km/h (mph)
CB14	DTT	07-12	16.1 (21.6)	1620 (3571)	Hydraulic	800 (31)	1051 (2318)	8.5 (5.0)
CB14 XW	DTT	07-12	16.1 (21.6)	1840 (4057)	Hydraulic	1000 (39)	1164 (2565)	8.5 (5.0)
CB14 Full Flush	DTT	07-12	16.1 (21.6)	1600 (3527)	Hydraulic	900 (35)	1051 (2318)	8.5 (5.0)
CB-214	6FD	85-88	24 (33)	2300 (5070)	Drum (2)	1000 (39.4)	2041 (4500)	10.6 (6.6)
CB-214B	6LF	88-93	24 (33)	2300 (5072)	Drum (2)	990 (39)	2018 (4450)	10.4 (6.5)
CB-214C	6LF	93-00	25 (33)	2320 (5115)	Drum (2)	1000 (39.4)	2592 (5715)	10.5 (6.5)
CB-214D	1TZ	99-03	23.5 (31.5)	2430 (5355)	Hydraulic	1000 (39.4)	2590 (5710)	10.0 (6.2)
CB-214E		-08	24.4 (32.7)	2450 (5400)	Hydraulic	1000 (39)	2751 (6075)	10.0 (6.0)
CB-224	6GD	85-88	24 (33)	2450 (5400)	Drum (2)	1200 (47.2)	2450 (5400)	10.6 (6.6)
CB-224B	6LF	88-93	24 (33)	2450 (5402)	Drum (2)	1199 (47.2)	2449 (5400)	10.4 (6.5)
CB-224C	6LF	93-00	25 (33)	2420 (5335)	Drum (2)	1200 (47.2)	2920 (6570)	10.5 (6.5)
CB-224D	8RZ	99-03	23.5 (31.5)	2610 (5750)	Hydraulic	1200 (47.2)	3039 (6700)	10.0 (6.2)
CB22		08-13	24.6 (33)	2500 (5512)	Hydraulic	1000 (39)	2817 (6210)	10.5 (6.5)
CB24		08-13	24.6 (33)	2700 (5952)	Hydraulic	1200 (47)	3195 (7043)	10.5 (6.5)
CB32		08-13	24.6 (33)	3230 (7121)	Hydraulic	1300 (51)	3195 (7043)	10.5 (6.5)
CC24		08-13	24.6 (33)	2400 (5291)	Hydraulic	1200 (47)	3195 (7043)	10.5 (6.5)
CB-224E		-08	24.4 (32.7)	2630 (5800)	Hydraulic	1200 (47)	3164 (6975)	10.0 (6.0)
CB-225D	9FZ	99-03	23.5 (31.5)	2390 (5270)	Hydraulic	1200 (47.2)	3039 (6700)	10.0 (6.2)
CB-225E		-08	24.4 (32.7)	2300 (5070)	Hydraulic	1200 (47)	3164 (6975)	10.0 (6.0)
CB-314	6HD	85-89	41 (55)	3357 (7400)	Drum	1120 (44)	2770 (6100)	8.0 (5.0)
CB-334D	3JZ 4CZ	98-03 98-02	32 (43)	3850 (8490)	Hydraulic	1300 (51)	3263 (7250)	11.0 (7.0)
CB-334E	DCZ	02-04 -08	34.1 (46)	3940 (8688)	Hydraulic	1300 (51)	3378 (7448)	12.5 (8.0)

Paving Products — Double Drum, Combi and Pneumatic Tire Compactors (cont'd)

Model	Product Ident. No. Prefix	Years Built	Flywheel kW (hp)	Approx. Op. Weight kg (lb)	Drive	Drum Width mm (in)	Centrifugal Force kg (lb)	Maximum Op. Speed km/h (mph)
CB-335D	5PZ BBW D4E	98-03 00-03 02-03	32 (43)	3620 (7980)	Hydraulic	1300 (51)	3263 (7250)	11.0 (7.0)
CB34		07-13	34.1 (46)	3940 (8688)	Hydraulic	1300 (51)	3378 (7448)	12.5 (8.0)
CC34		07-13	34.1 (46)	3670 (8091)	Hydraulic	1300 (51)	3378 (7448)	12.5 (8.0)
CB-335E		-08	34.1 (46)	3670 (8092)	Hydraulic	1300 (51)	3378 (7448)	12.5 (8.0)
CB-414	6KD	85-89	52 (70)	5780 (12,750)	Drum	1397 (55)	6350 (14,000)	13.7 (8.5)
CB-424	6LD	85-89	54 (73.5)	6220 (13,710)	Drum (2)	1397 (55)	4485 (9885)	11.0 (6.8)
CB-434	3TF	89-94	60 (80)	6610 (14,540)	Drum (2)	1422 (56)	7620 (16,800)	11.6 (7.2)
CB-434B	6AL	94-95	60 (80)	6577 (14,500)	Drums	1422 (56)	7620 (16,800)	0-11.6 (0-7.2)
CB-434C	4DN	95-03	52 (70)	6485 (14,300)	Hydraulic	1422 (56)	7620 (16,800)	11.6 (7.2)
CB-434D		04-11	62 (83)	7500 (16,535)	Hydraulic	1500 (59)	7960 (17,550)	11.6 (7.0)
CB-434D XW		04-11	62 (83)	7700 (16,975)	Hydraulic	1700 (67)	7960 (17,550)	11.6 (7.0)
CB-514	6YD	85-88	68 (91)	9730 (21,450)	Drum (2)	1730 (68)	9073 (20,000)	11.0 (7.0)
CB-521	6RD	85-87	61 (82)	8800 (19,404)	Wheel	1700 (67)	5300 (11,687)	15.0 (9.3)
CB-522	6SD	85-87	45 (62)	10 100 (22,271)	Drum (2)	1700 (67)	10 350 (22,822)	8.0 (5.0)
CB-523	6TD	85-87	61 (82)	8800 (19,404)	Wheel/ Drum	1700 (67)	5300 (11,687)	13.0 (8.0)
CB-524	6WD	85-87	61 (82)	9500 (20,948)	Drum (2)	1700 (67)	10 350 (22,822)	11.0 (6.8)
CB-534	6EG2YF	87-93	93 (125)	9117 (20,100)	Drum (2)	1700 (67)	11 800 (26,019)	11.2 (7.0)
CB-534B	4JL	93-95	80 (107)	9117 (20,100)	Drums	1676 (66)	12 043 (26,550)	0-11.3 (0-7.0)
CB-534C	5HN	95-02	75 (100)	9195 (20,270)	Drums	1700 (67)	11 975 (26,400)	11.3 (7.0)
CB-534D			97 (130)	10 380 (22,836)	Drums	1700 (67)	11 434 (25,208)	13.0 (8.0)
CB54		09-12	102 (137)	10 804 (23,818)	Hydraulic	1700 (67)	11 300 (24,929)	13.0 (8.0)
CB-534D XW			97 (130)	11 300 (24,860)	Drums	2000 (79)	11 434 (25,208)	13.0 (8.0)

Paving Products — Double Drum, Combi and Pneumatic Tire Compactors (cont'd)

Model	Product Ident. No. Prefix	Years Built	Flywheel kW (hp)	Approx. Op. Weight kg (lb)	Drive	Drum Width mm (in)	Centrifugal Force kg (lb)	Maximum Op. Speed km/h (mph)
CB-544	8FM	94-01	60 (80)	10 700 (23,593)	Drums	1700 (67)	8850 (19,510)	8.9 (5.5)
CB-545	2FS	96-01	60 (80)	9410 (20,750)	Wheel/ Drum	1700 (67)	8850 (19,510)	8.9 (5.5)
CB-564D			97 (130)	12 600 (27,783)	Drums	2130 (84)	10 085 (22,234)	13.0 (8.0)
CB-614	7CD	85-93	115 (155)	11 340 (25,000)	Drum (2)	1980 (78)	9525 (21,000)	11.2 (7.0)
CB-634	5CL	94-95	108 (145)		Drums	2134 (84)	12 043 (26,550)	0-9.2 (0-5.7)
CB-634C	3BR	95-01	108 (145)	11 680 (25,750)	Drums	2134 (84)	12 043 (26,550)	12.2 (7.6)
CD54		09-12	74.5 (99.5)	9500 (20,944)	Hydraulic	1700 (67)	8573 (18,900)	9.0 (5.5)
PF-200		85-92	49 (66)	7000 (15,430)	Wheel Pneumatic	1700 (67)	N/A	24.0 (14.9)
PS-110	7MD	85-96	57 (77)	12 500 (27,550)	Wheel Pneumatic	2134 (84)	N/A	38.6 (24.0)
PS-130	7ND	85-96	57 (77)	12 500 (27,550)	Wheel Pneumatic	1700 (67)	N/A	38.6 (24.0)
PS-150	7PD	85-96	57 (77)	15 050 (37,300)	Wheel Pneumatic	1700 (67)	N/A	38.6 (24.0)
PS-150B	3XR	95-04	52 (70)	12 940 (28,535)	Hydraulic	1743 (69)	N/A	25.6 (15.9)
PS-180	7PD	85-96	57 (77)	16 950 (37,000)	Wheel Pneumatic	1727 (68)	N/A	38.6 (24.0)
PS-200B	5JR	95-04	78 (105)	13 010 (28,685)	Hydraulic	1743 (69)	N/A	19.3 (12.0)
PS-300	7TD	85-95	77 (102)	21 000 (46,200)	Wheel Pneumatic	1900 (75)	N/A	26.5 (16.4)
PF-300	7WD	85-95	74 (105)	14 000 (30,860)	Wheel Pneumatic	1920 (77)	N/A	19.0 (11.8)
PS-300B			75 (100)	21 000 (46,200)	Wheel Pneumatic	1900 (75)		13.0 (8.0)
PS-300C			75 (100)	21 000 (46,200)	Wheel Pneumatic	1900 (75)		13.0 (8.0)
PS-360B			78 (105)	8500 (18,740)	Wheel Pneumatic	2275 (90)	N/A	18.0 (11.0)



UNDERGROUND MINING — HARD ROCK LOAD-HAUL-DUMPS (LHD'S)

LHD Model	Product Ident. No. Prefix (USA)	Years Built	Flywheel Power kW (hp)	Approx. Shipping Weight kg (lb)	Max. Capacity kg (lb)	Length m (ft)	Height m (ft)	Bucket Width mm (ft)	Breakout Force kg (lb)	Maximum Speeds km/h (mph)	
										Forward	Reverse
R1300	6QW	96-03	123 (165)	20 150 (44,430)	6500 (14,330)	8.66 (28'5")	2.00 (6'7")	2000 (6'7")	12 020 (26,500)	26.1 (16.2)	23.8 (14.6)
R1300G	LJB	03-13	123 (165)	20 950 (46,187)	6800 (14,991)	8.71 (28'7")	2.12 (6'11")	2200 (7'3")	12 020 (26,500)	24.0 (14.9)	23.0 (14.3)
R1300GII	RSL	06-08	136 (182)	20 875 (46,021)	6800 (14,991)	8.71 (28'7")	2.12 (6'11")	2200 (7'3")	15 350 (33,841)	26.1 (16.2)	25.9 (16.1)
R1500	BAY	86-00	178 (239)	25 100 (55,360)	9000 (19,850)	9.19 (30'2")	2.30 (7'7")	2480 (8'2")	18 460 (40,700)	30.4 (18.9)	33.0 (20.5)
R1600	9EW	97-03	201 (270)	29 800 (65,710)	10 200 (22,490)	9.71 (31'10")	2.40 (7'10")	2600 (8'6")	19 280 (42,510)	30.6 (19.0)	34.0 (21.1)
R1600	9XP	01-03	201 (270)	29 800 (65,710)	10 200 (22,490)	9.71 (31'10")	2.40 (7'10")	2600 (8'6")	19 280 (42,510)	30.6 (19.0)	34.0 (21.1)
R1600G	9PP	03-08	201 (270)	29 800 (65,700)	10 200 (22,490)	9.71 (31'10")	2.40 (7'10")	2600 (8'6")	19 000 (41,888)	22.9 (14.2)	23.8 (14.8)
R1600G	9YZ	07-13	201 (270)	29 800 (65,700)	10 200 (22,490)	9.71 (31'10")	2.40 (7'10")	2600 (8'6")	19 000 (41,888)	22.9 (14.2)	23.8 (14.8)
R1700 Series II	4LZ	94-00	231 (310)	34 500 (76,100)	12 000 (26,460)	10.42 (34'2")	2.53 (8'4")	2820 (9'3")	23 430 (51,660)	29.3 (18.2)	33.3 (20.7)
R1700G	8XZ	99-06	262/241 (351/323)	38 500 (84,878)	14 000* (30,865)*	10.59 (34'9")	2.56 (8'5")	2894 (9'6")	20 100 (44,313)	24.1 (15.0)	25.3 (15.7)
R2800	BBR	88-98	231 (310)	42 660 (94,070)	16 200 (35,720)	10.70 (35'1")	2.68 (8'10")	3000 (9'10")	26 540 (68,530)	29.3 (18.2)	33.3 (20.7)
R2900	5TW	95-03	269 (361)	48 850 (107,710)	17 200 (37,920)	10.97 (36'0")	2.89 (9'6")	3100 (10'2")	28 600 (63,060)	26.7 (16.6)	32.5 (20.2)
R2900G	GLK	02-05	306 (410)	50 100 (110,451)	17 200 (37,920)	11.3 (37'1")	2.89 (9'6")	3176 (10'5")	27 346 (60,298)	25.3 (15.7)	26.4 (16.4)
R2900G XTRA	GLK	02-05	306 (410)	53 100 (117,065)	20 000* (44,092)*	11.3 (37'1")	2.89 (9'6")	3400 (11'2")	27 346 (60,298)	25.3 (15.7)	26.4 (16.4)
R2900G XTRA	JLK	05-13	333 (447)	55 575 (122,522)	20 000* (44,092)*	11.3 (37'1")	2.99 (9'10")	3500 (11'6")	27 346 (60,298)	25.3 (15.7)	26.4 (16.4)

*Capacity is for tramming only. Truck loading capacity is lower.

Former Models

Underground Mining — Hard Rock Trucks

- Articulated Trucks
- Rigid Frame Trucks



UNDERGROUND MINING — HARD ROCK TRUCKS

Articulated Trucks

Truck Model	Product Ident. No. Prefix (USA)	Years Built	Flywheel Power kW (hp)	Approx. Shipping Weight kg (lb)	Max. Capacity kg (lb)	Length m (ft)	Height m (ft)	Body Width mm (ft)	Maximum Speeds km/h (mph)	
									Forward	Reverse
AD30	CXR	02-05	304 (408)	28 870 (63,647)	30 000 (66,139)	10.2 (33'4")	2.60 (8'6")	2690* (8'10")*	40.8 (25.4)	7.8 (4.8)
AD40	1YZ	94-02	380 (510)	38 100 (84,000)	40 000 (88,200)	10.7 (35'0")	2.70 (8'10")	3000 (9'10")	48.1 (29.9)	10.6 (6.6)
AD40 Series II	N/A	N/A	380 (510)	41 800 (92,170)	40 000 (88,200)	11.3 (37'0")	2.89 (9'6")	3200 (10'5")	41.7 (25.9)	9.6 (6.0)
AD45	BKZ	01-05	439 (589)	39 359 (86,772)	45 000 (99,208)	11.2 (36'9")	2.82 (9'5")	3000* (9'10")*	52.0 (32.3)	10.7 (6.6)
AD55	ANW	01-03	485 (650)	47 000 (103,617)	55 000 (121,254)	11.6 (37'11")	3.20 (10'6")	3346* (11'0")*	42.3 (26.3)	9.0 (5.6)
AD55B	JNW	07-13	600 (805)	50 000 (110,231)	55 000 (121,254)	12.0 (39'0")	3.4 (11'2")	3346* (11'0")*	41.5 (25.8)	8.7 (5.4)

Rigid Frame Trucks

69D Dump	9XS	00-04	380 (510)	30 100 (66,371)	38 000 (83,790)	8.1 (26'8")	3.4 (11'4")	3665 (12'0")	76.6 (47.6)	13.5 (8.4)
69D Ejector	9XS	00-04	380 (510)	34 700 (78,514)	36 200 (79,821)	7.8 (25'8")	3.4 (11'4")	3665 (12'0")	75.2 (46.7)	13.5 (8.4)

*Overall width less body.

- Continuous Miners
- LHDs
- Scoops



UNDERGROUND MINING – ROOM & PILLAR – CONTINUOUS MINERS

Model	Prefix	Exit Year	Bucyrus Model	Total Power kW (hp)	Cutter Head Power kW (hp)	Loading Capacity tonnes/min (Tons/min)	Recommended Mining Range mm (in)	Machine Weight tonnes (lb)
CM235	GEG	2014	25C	701 (940)	2 × 205 (2 × 275)	14-29 (15-32)	914-3251 (36-128)	61.2 (135,000)
CM330	GEY	2014	30M2	698 (930)	2 × 104 (2 × 280)	24 (26.5)	up to 3170 (up to 125)	61.7 (136,000)
CM845	GE6	2015	30MB	674 (904)	2 × 173 (2 × 232)	31.5 (35)	2800-3900 (110-153)	92.0 (202,800)



UNDERGROUND MINING – ROOM & PILLAR – LHDs

Model	Prefix	Exit Year	Bucyrus Model	Bucket Payload kg (lb)	Fork Payload kg (lb)	Engine	Engine Power kW (hp)	Machine Weight kg (lb)
CL106		2014	N/A					
CL110	LH4	2014	N/A	8000 (17,636)	10 000 (22,046)	Cat C7 ACERT	171.5 (230)	21 500 (47,400)
CL115	LH6	2014	N/A					
CL215B		2014	MH15					

26



UNDERGROUND MINING – ROOM & PILLAR – SCOOPS

Model	Prefix	Exit Year	Bucyrus Model	Lift Capacity tonnes (Tons)	Engine	Engine Power kW (hp)	Tram Speed km/h (mph)	Weight with Battery kg (lb)
SU482 DN (diesel non permissible)	LAW	2014	482D	6.8 (7.5)	Duetz BF4L 2011	58 (78)	16.9 (10.5)	
SU482	LAP	2014	488XL	6.4 (7.0)	Battery		8.0 (5.0)	
SU488 DM (dual motor)	LA4	2014	488-6 DM	14.5 (16.0)	Battery		8.0 (5.0)	26 853 (59,200)
SU488 D XP (explosion proof)		2014	488D XP	14.5 (16.0)	Duetz	112 (150)	17.9 (11.1)	
SU488 LHD	LA6	2014	488D LHD XP	10.9 (12.0)	Duetz 1013 FC	112 (150)	17.9 (11.1)	
SU488 LHD N	LA7	2014	488D LHD	10.9 (12.0)	Duetz 1013 FC	112 (150)	17.9 (11.1)	
SU488 DM AC (alternating current)	LA4	2014	488-6 DM	14.5 (16.0)	Battery		8.0 (5.0)	26 853 (59,200)
SU636		2014						

Former Models

Underground Mining – Room & Pillar

- Haulage (Face Haulers, Continuous Haulage)
- Feeder Breakers



UNDERGROUND MINING – ROOM & PILLAR – HAULAGE (FACE HAULERS, CONTINUOUS HAULAGE)

Model	Prefix	Exit Year	Bucyrus Model	Payload Capacity tonnes (Tons)	Machine Weight – empty kg (lb)	Minimum Operating Height mm (in)	Engine Type	Engine Power kW (hp)
FH110	FHM	2014	810C Un-a-trac	9.0 (10.0)	31 524 – with battery (69,500)	1066 (42)		
FH125 D	FHX	2014	FBR 15 Ram Car	20.0 (22.0)	25 000 – full tanks (55,115)	1900 (74.8)	Cat 3126	172 (230)
FH336 (Continuous Haulage)	FHZ	2014	36 CHH	27.0 (30.0)	27 216 (60,000)	965 (38)		



UNDERGROUND MINING – ROOM & PILLAR – FEEDER BREAKERS

Model	Prefix	Exit Year	Bucyrus Model	Capacity Throughput tonnes/hr (Tons/hr)	Minimum Operating Height mm (in)	Operating Weight kg (lb)	Total Power kW (hp)
FB75	FBP	2014	7MFBH-48A LOW	717 (790)	1270 (50)	31 751 (70,000)	151 (200)
			GH-MFBHM-48CDL	1089 (1200)	1219 (48)	27 215 (60,000)	151 (200)
FB75 P (permissible)	FBP	2014					
FB85	FBE	2014	7FB-56AL	860 (950)	836 (34)	31 750 (70,000)	150 (200)
FB85 P (permissible)	FBE	2014	7FB-56AL	860 (950)	837 (34)	31 750 (70,000)	151 (200)
FB110 P (permissible)	FBL	2014	7FB-48A	1146 (1263)	1219 (48)	31 750 (70,000)	151 (200)

- Roof Bolters
- Roof Support Carriers



UNDERGROUND MINING — ROOM & PILLAR — ROOF BOLTERS

Model	Prefix	Exit Year	Bucyrus Model	Drilling Torque N·m (lbf·ft)	Minimum Tram Height mm (ft)	Maximum ATRS Reach mm (ft)
RB120	RM9	2014	LRB-15AR	380 (280)	813 (2'8")	1930 (6'4")
RB230	RP9	2014	RB2-88A	420 (310)	1181 (3'10.5")	3048 (10'0")



UNDERGROUND MINING — ROOM & PILLAR — ROOF SUPPORT CARRIERS

Model	Prefix	Exit Year	Bucyrus Model	Lift Capacity – No Ballast tonnes (Tons)	Machine Weight kg (lb)	Tram Speed Level Unloaded km/h (mph)	Engine Type	Engine Power kW (hp)
SH650 VFD	RS6	2014	VT650	45.0 (50.0)	46 040 — with battery (101,500)	6.6 (4.1)	Battery	N/A
SH650 D	RS5	2014	VT650D	45.0 (50.0)	45 359 kg (100,000)	13.7 (8.5)	Cummins C8.3	179 (240)
SH660 D	JE3	2014	FBL-55	55.0 (60.625)	48 000 — tanks full (105,821)	19.5 (12.1)	Cat C7 ACERT	171.5 (230)

LAND CLEARING

CONTENTS

Variables Affecting Clearing Operations.	27-1
Job Surveys	27-2
Clearing Methods and Equipment	27-2
Equipment Selection Table	27-3
Production Estimating:	
General.	27-5
Cutting.	27-6
Piling	27-7
Work Tools.	27-9

Land clearing must be treated more as an art than a science because production rates and methods vary greatly from one area to another. This section deals with the many variables in clearing and includes methods, equipment and procedures to determine productivity rates.

VARIABLES AFFECTING CLEARING OPERATIONS

Vegetative Growth — Factors affecting production and therefore cost, include the number of trees, size of trees, wood density, root systems, vines and undergrowth. These factors can be estimated by a “tree-count” as discussed under “Job Survey.”

End Use of Land — Since different end uses require different degrees of clearing (i.e. highways, dams, tree crops, row crops, etc.), this is one of the most important factors to consider in choosing the proper clearing method and equipment.

Soil Conditions or Bearing Capacity — Factors affecting clearing operations include topsoil depth, soil type, moisture content, and the presence of rocks and stones.

Topography — Grade and terrain factors such as steep slopes, ditches, swampy areas, boulders and even ant hills greatly affect the normal operation of some equipment.

Rainfall and Climate — Usually all phases of land clearing from cutting to burning are concerned to some degree with temperature changes and the amount of rainfall during the clearing operation.

Job Specifications — Specifications dictate the degree of clearing to be done, area size, completion dates, method of debris disposal, soil conservation and other factors which affect method and equipment selection.

JOB SURVEYS

Knowledge of rainfall and climate, end use of the land, and job specifications can be obtained from records, surveys, engineering studies, and written specifications. You should personally review the land to be cleared to gain other necessary and valuable information.

The survey should include a study of general topography and soil conditions. Note such problem factors as hills, rocks, or swamps which would significantly affect production or which would require special treatment.

Cruise the area to be cleared and determine the acreage of each vegetative type (i.e. upland woods, low timberlands, swamps). Make at least three tree counts at random for each vegetation type. To conduct these counts, randomly locate two points 100 meters (328 feet) apart. Count and measure vegetative growth along a straight line between these points for a width of about 5 meters (16 feet) on both sides. This gives the population of 1/10 hectare (1/4 acre).

1. Density of vegetation less than 30 cm (12 in) diameter
 - Dense — 1480 trees/hectare or more
(600 trees/acre)
 - Medium — 990-1480 trees/hectare
(400-600 trees/acre)
 - Light — less than 990 trees/hectare
(400 trees/acre)
2. Presence of hardwoods expressed in percent
3. Presence of heavy vines
4. Average number of trees per hectare (2.47 acres) in each of the following ground level diameter size ranges:
 - Less than 30 cm (1 ft)
 - 31 cm-60 cm (1-2 ft)
 - 61 cm-90 cm (2-3 ft)
 - 91 cm-120 cm (3-4 ft)
 - 121 cm-180 cm (4-6 ft)
5. Sum of diameter of all trees per hectare (2.47 acres) above 180 cm (6 ft) in diameter at ground level.

CLEARING METHODS AND EQUIPMENT

Methods for Initial Felling — There are several methods indicating the degree of clearing for initial felling and several types of equipment for use with each method. Equipment use in different size vegetation and different size areas is summarized in the table on the next page. This information should serve only as a rough guideline in selecting equipment. The economical land area for each type of equipment will vary with the capital cost of equipment and moving cost. It is also affected by whether there are alternate uses for equipment such as using tractors for other construction work or tillage.

Land Clearing Machines — Job size, severity of job such as tree size, and time limit to complete will influence machine selection. Some machines, such as purpose built forestry equipment and track-type tractors are more suited for this type of work than others, but imagination and resourcefulness can allow the use of other types of machines in specific applications. For example, loaders are used more today in raking and piling operations than ever before.

Operator Protection and Machine Guarding — Daily production has been estimated to increase 20% when cab guards are used. Cabs designed specifically for forestry and clearing applications are available on purpose built Cat® forestry equipment. Auxiliary equipment manufacturers such as Rome™ offer after market guard packages for non-purpose built units.

Locally designed and manufactured guarding for non-purpose built equipment is required. The radiator, engine, and underside of the tractor must be well protected. Perforated hoods, screens, crankcase guards and hydraulic cylinder guards are generally recommended.

Generally speaking lower cost clearing can be done with purpose built forestry equipment and larger tractors if the amount of clearing involved is sufficient to merit the initial investment of purpose built or if the amount of clearing involved is sufficient to merit the initial investment in the bigger machine. In applications where track-type tractors are used, power shift transmissions should be standard due to the frequent direction changes. The direct drive transmission tractor is recommended when the tractor is used principally in constant drawbar work such as chaining or pulling a disc harrow. In most applications, a winch should also be considered on one of every three tractors in a fleet.

EQUIPMENT SELECTION TABLE

	UPROOTING	CUTTING AT OR ABOVE GROUND LEVEL	KNOCKING TO THE GROUND	INCORPORATING INTO THE SOIL
LIGHT CLEARING — Vegetation up to 5 cm (2 in) diameter				
Small areas 4 hectares (10 acres)	Bulldozer blade; forestry machine road builder arrangement	Wheel-mounted circular saws	Bulldozer blade; forestry machine road builder arrangement	Moldboard plows, disc plows, disc harrows
Medium areas 40 hectares (100 acres)	Bulldozer blade; forestry machine road builder arrangement	Heavy duty sickle mowers [up to 3.7 cm (1½ in) diameter] tractor-mounted circular saws, suspended rotary mowers; site prep tractor with brush cutter or mulcher attachment	Bulldozer blade, rotary mowers; flail-type rotary cutters; rolling brush cutters; forestry machine road builder arrangement; site prep tractor with brush cutter or mulcher attachment	Moldboard plows; disc plows, disc harrows; site prep tractor with mulcher attachment
Large areas 400 hectares (1000 acres)	Bulldozer blade, root rake, grubber, root plow, anchor chain drawn between two crawler tractors; rails	Site prep tractor with brush cutter or mulcher attachment	Rolling brush cutter; flail-type cutter; anchor chain drawn between two crawler tractors; rails; site prep tractor with brush cutter or mulcher attachment	Undercutter with disc; moldboard plows; disc plows; disc harrows; site prep tractor with mulcher attachment
INTERMEDIATE CLEARING — Vegetation 5 to 20 cm (2 to 8 in) diameter				
Small areas 4 hectares (10 acres)	Bulldozer blade; forest machine road builder arrangement	Wheel-mounted circular saws	Bulldozer blade; forestry machine road builder arrangement	Heavy-duty disc plow; disc harrow
Medium areas 40 hectares (100 acres)	Bulldozer blade; forest machine road builder arrangement	Tractor-mounted circular saws, single scissor type tree shears; site prep tractor with brush cutter or mulcher attachment; wheel/track feller buncher with high speed saw head; forest machine with directional felling head	Bulldozer blade, rolling brush cutter [up to 12 cm (5 in) diameter], rotary mower [up to 10 cm (4 in) diameter]; forestry machine road builder arrangement; Site prep tractor with brush cutter or mulcher attachment	Heavy-duty disc plow; disc harrow; site prep tractor with mulcher attachment
Large areas 400 hectares (1000 acres)	Shearing blade, angling (tilted) bulldozer blade, rakes, anchor chain drawn between two crawler tractors, root plow	Shearing blade (angling or V-type); site prep tractor with brush cutter or mulcher attachment; wheel/track feller buncher with high speed saw head; forest machine with directional felling head	Bulldozer blade, flail-type rotary cutter, anchor chain; site prep tractor with brush cutter or mulcher attachment	Bulldozer blade with duty harrow; site prep tractor with mulcher attachment

NOTE: The most economical size area for each type of equipment will vary with the relative cost of capital equipment versus labor. It is also affected by whether there are alternate uses for equipment such as using tractors for tillage.

EQUIPMENT SELECTION TABLE

	UPROOTING	CUTTING AT OR ABOVE GROUND LEVEL	KNOCKING TO THE GROUND	INCORPORATING INTO THE SOIL
LARGE CLEARING — Vegetation 20 cm (8 in) diameter or larger				
Small areas 4 hectares (10 acres)	Bulldozer blade; forest machine road builder arrangement; Forest machine with directional felling head	—	Bulldozer blade; forest machine road builder arrangement; forest machine with directional felling head	—
Medium areas 40 hectares (100 acres)	Shearing blade, angling (tilted), knockdown beam, rakes, tree stumper; forest machine road builder arrangement; forest machine with directional felling head	Shearing blade (angling or V-type), tree shear [up to 70 cm (26 in) softwood; 35 cm (14 in) hardwood], shearing blade — power saw combination; wheel/ track feller buncher with high speed saw head; forest machine with directional felling head	Bulldozer blade; forest machine road builder arrangement; forest machine with directional felling head	—
Large areas 400 hectares (1000 acres)	Shearing blade, angling (tilted), tree pusher, rakes, tree stumper, anchor chain with ball drawn between two crawler tractors; forest machine with directional felling head	Shearing blade (angling or V-type), shearing blade — power saw combination; wheel/track feller buncher with high speed saw head; forest machine with directional felling head	Anchor chain with ball drawn between two crawler tractors. [Use dozer blade for trees over 18 cm (7 in).]; forest machine road builder arrangement; forest machine with directional felling head	—

NOTE: The most economical size area for each type of equipment will vary with the relative cost of capital equipment versus labor. It is also affected by whether there are alternate uses for equipment such as using tractors for tillage.

PRODUCTION ESTIMATING

GENERAL — CONSTANT SPEED OPERATIONS

Production is the hourly clearing rate usually expressed in hectares or acres.

For many land clearing operations, production is calculated by multiplying the tractor speed by the width of cut and converting to hectares or acres per hour.

Metric system:

The base formula is:

$$\frac{\text{Width of cut (meters)} \times \text{speed (km/h)}}{10} = \text{hectares/h}$$

When an efficiency of 82.5% is used, the formula becomes:

$$\frac{\text{Width of cut (m)} \times \text{speed (km/h)} \times 0.825}{10} = \text{hectares/h}$$

English measure:

$$\frac{\text{Width of cut (ft)} \times \text{speed (mph)}}{43,560 (\text{ft}^2)} = \text{acres/hr}$$

The American Society of Agricultural Engineers formula for estimating hourly production of a constant speed operation is based on 82.5% efficiency. With this efficiency, the formula becomes:

$$\frac{\text{Width of cut (ft)} \times \text{speed (mph)} \times 0.825}{43,560 (\text{ft}^2)} = \text{acres/hr}$$

Width of cut is the effective working width of the equipment and may not be the same as its rated width. Working width should be measured on the job but can be estimated when necessary.

The actual machine speed can be determined by measuring the amount of time to travel a given distance. When using the metric system, the time to travel 16.7 meters or a multiple thereof, can be converted into kilometers per hour.

$$\frac{1.0}{\text{(Time in min. to travel 16.7 meters)}} = \text{speed (kmh)}$$

Since 88 ft/min. equals one mph, the lapsed time to travel 88 ft, or a multiple of 88 ft, can easily be converted into miles per hour.

$$\frac{1.0}{\text{(Time in min. to travel 88 ft)}} = \text{speed (mph)}$$

The following nomographs in both the Metric and English systems convert speed and width of cut directly into acres or hectares per hour at 82.5% efficiency without the need for calculations.

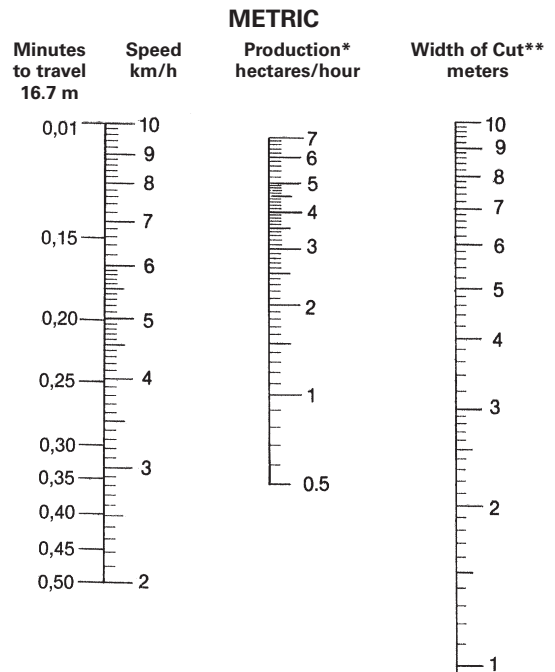

*Based on 82.5% efficiency.

**When width of cut exceeds 10 meters, use a multiple of the width of cut and increase production proportionately.

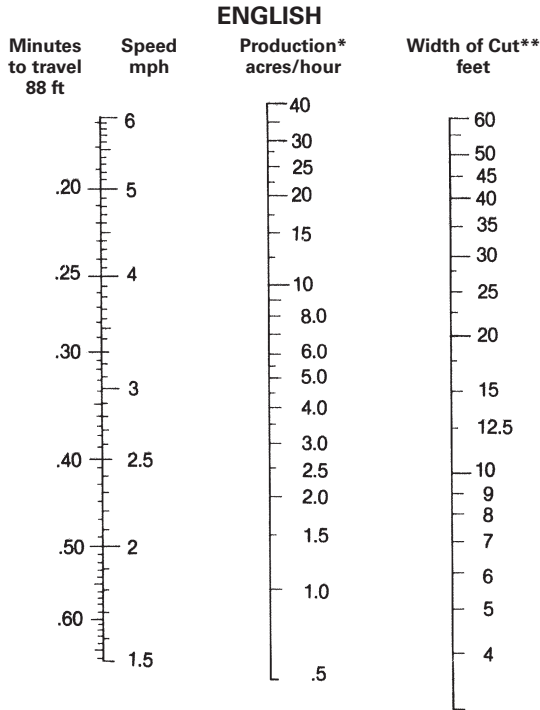

*Based on 82.5% efficiency.

**When width of cut exceeds 60 feet, use a multiple of the width of cut and increase production proportionately.

CUTTING PRODUCTION ESTIMATING

Most land clearing operations such as bulldozing, cutting, grubbing, raking and piling are not performed at constant speed. Because off-the-job production is difficult to estimate for these operations, Rome Industries has developed formulas for estimating cutting and piling time. These formulas take into consideration variable prime mover speeds through a factor, "B", the base time for each tractor to cover one hectare (2.47 acres) of light material.

To estimate **tractor cutting time per hectare** (2.47 acres) on a specific land clearing job, apply the factors shown in the following table, together with data obtained from the job survey, in the formula:

$$T = X [A(B)+M_1N_1+M_2N_2+M_3N_3+M_4N_4+DF]$$

where

- T = Time per hectare (2.47 acres) in minutes
- X = Hardwood or density factor affecting total time

- A = Density or vine presence factor affecting base time
- B = Base time for each tractor per hectare (2.47 acres)
- M = Minutes per tree in each diameter range
- N = Number of trees per hectare (2.47 acres) in each diameter range obtained from field survey
- D = Sum of diameter in 30 cm (1 ft) increments of all trees per hectare (2.47 acres) above 180 cm (6 ft) in diameter at ground level obtained from field survey
- F = Minutes per 30 cm (1 ft) of diameter for trees above 180 cm (6 ft) in diameter.

Hardwoods affect over-all or total time as follows:

- 75-100% hardwoods: Add 30% to total time (X = 1.3)
- 25-75% hardwoods: No change (X = 1.0)
- 0-25% hardwoods: Subtract 30% from total time (X = 0.7)

Production Factors for Felling with Rome K/G Blades

Tractor	Base Minutes per hectare (2.47 acres) "B"	Diameter Range				Dia. above 180 cm per 30 cm (6' per foot) "F"
		30-60 cm (1-2 ft) "M ₁ "	60-90 cm (2-3 ft) "M ₂ "	90-120 cm (3-4 ft) "M ₃ "	120-180 cm (4-6 ft) "M ₄ "	
165 hp	85	0.7	3.4	6.8	—	—
230 hp	58	0.5	1.7	3.3	10.2	3.3
305 hp	45	0.2	1.3	2.2	6.0	1.8
405 hp	39	0.1	0.4	1.3	3.0	1.0

Explanation of columns in table:

Tractor — Based on current model tractors (power shift when applicable) working on reasonably level terrain (below 10% grade) with good footing, no stones, average mixture of soft and hard woods. Tractor is in proper operating condition, blade is sharp, and properly adjusted.

Base Minutes — The base figures represent the number of minutes required for each tractor to cover a hectare (2.47 acres) of light material where no trees require splitting or other individual treatment. Time required is affected by the density of material less than 30 cm (1 ft) in diameter and the presence of vines.

- a. dense — 1480 trees/hectare (600 or more trees/acre): Add 100% to base time (A = 2.0)
- b. medium — 990-1480 trees/hectare (400-600 trees/acre): No change (A = 1.0)
- c. light — less than 990 trees/hectare (400 trees/acre): Subtract 30% from total time (A = 0.7)

Presence of heavy vines: Add 100% to base time (A=2.0). *Very* heavy vines add 300% to base time. (A=3.0)

Dia. Range — M₁ represents minutes required to cut from 31-60 cm (1-2 ft) in diameter at ground level.

M₂ same for trees 61-90 cm (2-3 ft) diameter.

M₃ same for trees 91-120 cm (3-4 ft) diameter.

M₄ same for trees 121-180 cm (4-6 ft) diameter.

For Dia. above 180 cm (6 ft) — The figures in this column represent size the number of minutes required per 30 cm (1 ft) of diameter for each tractor to cut trees above 180 cm (6 ft) in diameter. Thus, to fell a 240 cm (8 ft) diameter tree would require 8 × 1.8 or approximately 14.4 minutes with a D8T.

Example problem:

Calculate the felling production of a D8T with K/G Blade in these conditions: reasonably level terrain, firm ground, well drained, 85% hardwoods with heavy vines and the following average tree count per hectare (2.47 acre):

Diameter Range	Less than 30 cm (1 ft) "B"	31-60 cm (1-2 ft) "N ₁ "	61-90 cm (2-3 ft) "N ₂ "	91-120 cm (3-4 ft) "N ₃ "	121-180 cm (4-6 ft) "N ₄ "	Sum Dia's Above 180 cm (6 ft) "D"
Number of Trees	1100	35	6	6	4	488 cm (16 ft)

Solution:

$$\begin{aligned}
 T &= X [A(B)+M_1N_1+M_2N_2+M_3N_3+M_4N_4+DF] \\
 T &= 1.3 [2.0 (45)+0.2 (35)+1.3 (6)+2.2 (6)+6 (4)+16 (1.8)] \\
 &= 1.3 (90+7+7.8+13.2+24+28.8) \\
 &= 1.3 (170.8) \\
 &= 222 \text{ minutes/hectare (90 min/acre)}
 \end{aligned}$$



Where the job requires grubbing trees and stumps greater than 30 cm (1 ft) in diameter at the same time the trees are sheared, use the same basic procedure as defined above including the variables for the presence of hardwoods. After time per hectare (acre) in minutes has been determined, increase the over-all or total time by 25%.

Where the job requires re-entering the area (after all trees have been sheared) to remove stumps with a tilted shearing blade or stump, increase the total time by 50%.

PILING PRODUCTION ESTIMATING

A procedure has also been developed for estimating piling production for a tractor equipped with a K/G blade or rake.

To estimate tractor hours per hectare (acre) on a specific land clearing job, apply the factors shown in the following table with data obtained from the job survey, in the formula:

$$T = B + M_1N_1 + M_2N_2 + M_3N_3 + M_4N_4 + DF$$

where

T = Time per hectare (2.47 acre) in minutes.

B = Base time for each tractor per hectare (2.47 acre).

M = Minutes per tree in each diameter range.

N = Number of trees per hectare (2.47 acre) in each diameter range obtained from field cruise.

D = Sum of diameter in 30 cm (1 ft) increments of all trees per hectare (2.47 acre) above 180 cm (6 ft) in diameter at ground level obtained from field cruise.

F = Minutes per 30 cm (1 ft) of diameter for trees above 180 cm (6 ft) in diameter.

Production Factors for Piling in Windrows*

Tractor	Base Minutes per hectare (2.47 acres) "B"	Diameter Range				Dia. above 180 cm per 30 cm (6' per foot) "F"
		30-60 cm (1-2 ft) "M ₁ "	60-90 cm (2-3 ft) "M ₂ "	90-120 cm (3-4 ft) "M ₃ "	120-180 cm (4-6 ft) "M ₄ "	
165 hp	157	0.5	1.0	4.2	—	—
230 hp	125	0.4	0.7	2.5	5.0	—
305 hp	111	0.1	0.5	1.8	3.6	0.9
405 hp	97	0.08	0.1	1.2	2.1	0.3

*May be used with most types of raking tools and angled shearing blade. Windrows to be spaced approximately 61 meters (200 feet) apart.

Explanation of columns in table:

Tractor — Production with tractor working alone based on current model tractors (power shift when applicable) working on reasonably level (below 10% grade) terrain with good footing, no stones, average mixture of soft and hard woods. The tractor is in proper operating condition. Decrease total time by 25-50% depending on the number and size of trees when using three or more tractors in combination.

Base Minutes — The base figures represent the number of minutes required for each tractor to cover a hectare (2.47 acres) of light material.

Dia. Range — M_1 represents minutes required to pile trees from 31-60 cm (1-2 ft) diameter at ground level.

M_2 same for trees 61-90 cm (2-3 ft) diameter.

M_3 same for trees 91-120 cm (3-4 ft) diameter.

M_4 same for trees 121-180 cm (4-6 ft) diameter.

For Dia. above 180 cm (6 ft) — The figures in this column represent for each tractor size the number of minutes required per 30 cm (1 ft) of diameter to pile trees above 180 cm (6 ft) in diameter. Thus, to pile a 240 cm (8 ft) diameter tree would require 8×0.9 or approximately 7.2 minutes with a D8T tractor.

Where the job requires piling of grubbed trees and stumps greater than 30 cm (1 ft) in diameter, use the same basic procedure defined above and then increase over-all or total time by 25%.

In dense small diameter brush with few or no large trees, or when cutting is vine entangled, reduce the base time by 30%.

Example problem:

Calculate the windrow piling production of a D7R Series 2 with Rake in level terrain, no grubbing, and average mixture of hardwoods and softwoods where the average tree count per hectare (2.47 acres) is:

Diameter Range	Less than 30 cm (1 ft) "B"	31-60 cm (1-2 ft) "N ₁ "	61-90 cm (2-3 ft) "N ₂ "	91-120 cm (3-4 ft) "N ₃ "	121-180 cm (4-6 ft) "N ₄ "	Sum Dia's Above 180 cm (6 ft) "D"
Number of Trees	1100	35	6	6	2	0

Solution:

$$\begin{aligned}
 T &= B + M_1N_1 + M_2N_2 + M_3N_3 + M_4N_4 + DF \\
 &= 125 + 0.4(35) + 0.6(6) + 2.5(6) + 5.0(2) + [DF=0] \\
 &= 42.6 \\
 &= 177.6 \text{ minutes/hectare (72 min/acre)}
 \end{aligned}$$



To find the number of machines required for each operation, use the formula:

$$\text{Hr/hectare (acre)} \times \text{number of hectares (acres)} = \text{number of machines needed}^*$$

*Average machine production for all operation in hr/hectare (acre).

To cost estimate each method or phase of operation, use this calculation:

$$\text{Owning and Operating cost/hr} \times \text{hr/hectare (acre)} \times \text{number of hectares (acres)} = \text{cost}$$

Because of the many variables that increase or decrease production, these formulas should be considered only as guidelines in arriving at a rough production estimate. This estimate should be tempered by personal judgment based on past experience and personal knowledge of the area.

BLADE RAKES

Tractor Model and Dozer		D6T			D7R Series 2		
		6A	6S	6S LGP	7A	7S	7S LGP
Raking Width	m	3.3	2.62	3.3	3.72	3.18	3.66
	ft	10'10"	8'6"	10'10"	12'3"	10'5"	12'
Opening at Tooth Tips	mm	356	305	310	381	381	381
	in	14"	12"	12.22"	15"	15"	15"
Tooth Penetration	mm	432	457	406	559	559	559
	ft/in	17"	18"	16"	1'10"	1'10"	1'10"
Total Weight	kg	718	675	825	1144	1100	1119
	lb	1585	1490	1820	2525	2420	2470

RAKES FOR WHEEL LOADERS

Wheel Loader Model and Rake Type		910K/ 914K Loader Rake	924K (HRC/LRC) Loader Rake		930K (HRC/LRC) Loader Rake		938K (HRC/LRC) Loader Rake		950K/ 950M/ 962K/ 962M Loader Rake	966K/ 966M/ 972K/ 972M Loader Rake
		Raking Width	mm	2210	2146	2495	2146	2495	2495	2844
	ft	7'3"	7'0"	8'2"	7'0"	8'2"	8'2"	9'4"	9'4"	10'4"
Tooth Penetration	mm	762	520	520	520	520	520	520	520	559
	ft	2'6"	1'8"	1'8"	1'8"	1'8"	1'8"	1'8"	1'8"	1'10"
Opening at Tooth Tips	mm	318	299	299	299	299	299	299	299	330
	in	12.75"	12"	12"	12"	12"	12"	12"	12"	13"
Rake Weight	kg	770	1960	1338	1960	1338	1338	2230	1477	2085
	lb	1700	4322	2950	4322	2950	2950	4917	3257	4597

RAKES FOR TRACK LOADERS

Track Loader Model and Rake Type		953D Loader Rake	963D Loader Rake
Raking Width	mm	2845	2388
	ft	9'4"	7'10"
Tooth Penetration	mm	635	635
	ft	2'1"	2'1"
Opening at Tooth Tips	mm	298	330
	in	11.75"	13"
Rake Weight	kg	1450	1450
	lb	3200	3200

This listing is not all-inclusive. Contact your Cat dealer for special attachment needs.

MINING AND EARTHMOVING

CONTENTS

Elements of Production	28-1
Volume Measure	28-2
Swell	28-2
Load Factor	28-2
Material Density	28-2
Fill Factor	28-3
Soil Density Tests	28-3
Figuring Production On-the-Job	28-4
Load Weighing	28-4
Time Studies	28-4
English Example	28-4
Metric Example	28-5
Estimating Production Off-the-Job	28-5
Rolling Resistance	28-5
Grade Resistance	28-6
Total Resistance	28-6
Traction	28-6
Altitude	28-7
Job Efficiency	28-8
English Example	28-8
Metric Example	28-10
Systems	28-13
Economic Haul Distances	28-13
Production Estimating	28-14
Loading Match	28-14
Fuel Consumption and Productivity	28-14
Formulas and Rules of Thumb	28-15

INTRODUCTION

This section explains the earthmoving principles used to determine machine productivity. It shows how to calculate production on-the-job or estimate production off-the-job.

Machine performance is usually measured on an hourly basis in terms of machine productivity and machine owning and operating cost. Optimum machine performance can be expressed as follows:

$$\text{Lowest cost per ton} = \frac{\text{Lowest Possible Hourly Costs}}{\text{Highest Possible Hourly Productivity}}$$

ELEMENTS OF PRODUCTION

Production is the hourly rate at which material is moved. Production can be expressed in various units:

Metric

Bank Cubic Meters	— BCM —	bank m ³
Loose Cubic Meters	— LCM —	loose m ³
Compacted Cubic Meters	— CCM —	compacted m ³
Tonnes		

English

Bank Cubic Yards	— BCY —	bank yd ³
Loose Cubic Yards	— LCY —	loose yd ³
Compacted Cubic Yards	— CCY —	compacted yd ³
Tons		

For most earthmoving and material handling applications, production is calculated by multiplying the quantity of material (load) moved per cycle by the number of cycles per hour.

$$\text{Production} = \text{Load/cycle} \times \text{cycles/hour}$$

The load can be determined by

- 1) load weighing with scales
- 2) load estimating based on machine rating
- 3) surveyed volume divided by load count
- 4) machine payload measurement system

Generally, earthmoving and overburden removal for coal mines are calculated by volume (bank cubic meters or bank cubic yards). Metal mines and aggregate producers usually work in weight (tons or tonnes).

Volume Measure — Material volume is defined according to its state in the earthmoving process. The three measures of volume are:

- BCM (BCY) — one cubic meter (yard) of material as it lies in the natural bank state.
- LCM (LCY) — one cubic meter (yard) of material which has been disturbed and has swelled as a result of movement.
- CCM (CCY) — one cubic meter (yard) of material which has been compacted and has become more dense as a result of compaction.

In order to estimate production, the relationships between bank measure, loose measure, and compacted measure must be known.

Swell — Swell is the percentage of original volume (cubic meters or cubic yards) that a material increases when it is removed from the natural state. When excavated, the material breaks up into different size particles that do not fit together, causing air pockets or voids to reduce the weight per volume. For example to hold the same weight of one cubic unit of bank material it takes 30% more volume (1.3 times) after excavation. (Swell is 30%.)

$$1 + \text{Swell} = \frac{\text{Loose cubic volume for a given weight}}{\text{Bank cubic volume for the same given weight}}$$

$$\text{Bank} = \frac{\text{Loose}}{(1 + \text{Swell})}$$

$$\text{Loose} = \text{Bank} \times (1 + \text{Swell})$$

Example Problem:

If a material swells 20%, how many loose cubic meters (loose cubic yards) will it take to move 1000 bank cubic meters (1308 bank cubic yards)?

$$\begin{aligned} \text{Loose} &= \text{Bank} \times (1 + \text{Swell}) = \\ &1000 \text{ BCM} \times (1 + 0.2) = 1200 \text{ LCM} \\ &1308 \text{ BCY} \times (1 + 0.2) = 1570 \text{ LCY} \end{aligned}$$

How many bank cubic meters (yards) were moved if a total of 1000 loose cubic meters (1308 yards) have been moved? Swell is 25%.

$$\begin{aligned} \text{Bank} &= \text{Loose} \div (1 + \text{Swell}) = \\ &1000 \text{ LCM} \div (1 + 0.25) = 800 \text{ BCM} \\ &1308 \text{ LCY} \div (1 + 0.25) = 1046 \text{ BCY} \end{aligned}$$

Load Factor — Assume one bank cubic yard of material weighs 3000 lb. Because of material characteristics, this bank cubic yard swells 30% to 1.3 loose cubic yards when loaded, with no change in weight. If this 1.0 bank cubic yard or 1.3 loose cubic yards is compacted, its volume may be reduced to 0.8 compacted cubic yard, and the weight is still 3000 lb.

Instead of dividing by 1 + Swell to determine bank volume, the loose volume can be multiplied by the load factor.

If the percent of material swell is known, the load factor (L.F.) may be obtained by using the following relationship:

$$\text{L.F.} = \frac{100\%}{100\% + \% \text{ swell}}$$

Load factors for various materials are listed in the Tables Section of this handbook.

To estimate the machine payload in bank cubic yards, the volume in loose cubic yards is multiplied by the load factor:

$$\text{Load (BCY)} = \text{Load (LCY)} \times \text{L.F.}$$

The ratio between compacted measure and bank measure is called shrinkage factor (S.F.):

$$\text{S.F.} = \frac{\text{Compacted cubic yards (CCY)}}{\text{Bank cubic yards (BCY)}}$$

Shrinkage factor is either estimated or obtained from job plans or specifications which show the conversion from compacted measure to bank measure. Shrinkage factor should not be confused with percentage compaction (used for specifying embankment density, such as Modified Proctor or California Bearing Ratio [CBR]).

Material Density — Density is the weight per unit volume of a material. Materials have various densities depending on particle size, moisture content and variations in the material. The denser the material the more weight there is per unit of equal volume. Density estimates are provided in the Tables Section of this handbook.

$$\text{Density} = \frac{\text{Weight}}{\text{Volume}} = \frac{\text{kg (lb)}}{\text{m}^3 (\text{yd}^3)}$$

$$\text{Weight} = \text{Volume} \times \text{Density}$$

A given material's density changes between bank and loose. One cubic unit of loose material has less weight than one cubic unit of bank material due to air pockets and voids. To correct between bank and loose use the following equations.

$$1 + \text{Swell} = \frac{\text{kg/BCM}}{\text{kg/LCM}} \text{ or } \frac{\text{lb/BCY}}{\text{lb/LCY}}$$

$$\text{lb/LCY} = \frac{\text{lb/BCY}}{(1 + \text{Swell})}$$

$$\text{lb/BCY} = \text{lb/LCY} \times (1 + \text{Swell})$$

Fill Factor — The percentage of an available volume in a body, bucket, or bowl that is actually used is expressed as the fill factor. A fill factor of 87% for a hauler body means that 13% of the rated volume is not being used to carry material. Buckets often have fill factors over 100%.

Example Problem:

A 14 cubic yard (heaped 2:1) bucket has a 105% fill factor when operating in a shot sandstone (4125 lb/BCY and a 35% swell).

- What is the loose density of the material?
 - What is the usable volume of the bucket?
 - What is the bucket payload per pass in BCY?
 - What is the bucket payload per pass in tons?
- $\text{lb/LCY} = \text{lb/BCY} \div (1 + \text{Swell}) = 4125 \div (1.35) = 3056 \text{ lb/LCY}$
 - $\text{LCY} = \text{rated LCY} \times \text{fill factor} = 14 \times 1.05 = 14.7 \text{ LCY}$
 - $\text{lb/pass} = \text{volume} \times \text{density lb/LCY} = 14.7 \times 3056 = 44,923 \text{ lb}$
 $\text{BCY/pass} = \text{weight} \div \text{density lb/BCY} = 44,923 \div 4125 = 10.9 \text{ BCY}$
 or bucket LCY from part b $\div (1 + \text{Swell}) = 14.7 \div 1.35 = 10.9 \text{ BCY}$
 - $\text{tons/pass} = \text{lb} \div 2000 \text{ lb/ton} = 44,923 \div 2000 = 22.5 \text{ tons}$

Example Problem:

Construct a 10,000 compacted cubic yard (CCY) bridge approach of dry clay with a shrinkage factor (S.F.) of 0.80. Haul unit is rated 14 loose cubic yards struck and 20 loose cubic yards heaped.

- How many bank yards are needed?
- How many loads are required?

$$\text{a) } \text{BCY} = \frac{\text{CCY}}{\text{S.F.}} = \frac{10,000}{0.80} = 12,500 \text{ BCY}$$

$$\text{b) } \text{Load (BCY)} = \text{Capacity (LCY)} \times \text{Load factor (L.F.)} = 20 \times 0.81 = 16.2 \text{ BCY/Load}$$

(L.F. of 0.81 from Tables)

$$\text{Number of loads required} = \frac{12,500 \text{ BCY}}{16.2 \text{ BCY/Load}} = 772 \text{ Loads}$$



Soil Density Tests — There are a number of acceptable methods that can be used to determine soil density. Some that are currently in use are:

- Nuclear density moisture gauge
- Sand cone method
- Oil method
- Balloon method
- Cylinder method

All these except the nuclear method use the following procedure:

- Remove a soil sample from bank state.
- Determine the volume of the hole.
- Weigh the soil sample.
- Calculate the bank density kg/BCM (lb/BCY).

The nuclear density moisture gauge is one of the most modern instruments for measuring soil density and moisture. A common radiation channel emits either neutrons or gamma rays into the soil. In determining soil density, the number of gamma rays absorbed and back scattered by soil particles is *indirectly* proportional to the soil density. When measuring moisture content, the number of moderated neutrons reflected back to the detector after colliding with hydrogen particles in the soil is *directly* proportional to the soil's moisture content.

All these methods are satisfactory and will provide accurate densities when performed correctly. Several repetitions are necessary to obtain an average.

NOTE: Several newer methods have been successfully applied, along with weigh scales to determine volume and loose density of material moved in hauler bodies. These measurements include photographic and laser scanning technologies.

- Load Weighing
- Time Studies
- Example (English)

FIGURING PRODUCTION ON-THE-JOB

Load Weighing — The most accurate method of determining the actual load carried is by weighing. This is normally done by weighing the haul unit one wheel or axle at a time with portable scales. Any scales of adequate capacity and accuracy can be used. While weighing, the machine must be level to reduce error caused by weight transfer. Enough loads must be weighed to provide a good average. Machine weight is the sum of the individual wheel or axle weights.

The weight of the load can be determined using the empty and loaded weight of the unit.

Weight of

$$\text{load} = \text{gross machine weight} - \text{empty weight}$$

To determine the bank cubic measure carried by a machine, the load weight is divided by the bankstate density of the material being hauled.

$$\text{BCY} = \frac{\text{Weight of load}}{\text{Bank density}}$$

Times Studies — To estimate production, the number of complete trips a unit makes per hour must be determined. First obtain the unit's cycle time with the help of a stop watch. Time several complete cycles to arrive at an average cycle time. By allowing the watch to run continuously, different segments such as load time, wait time, etc. can be recorded for each cycle. Knowing the individual time segments affords a good opportunity to evaluate the balance of the spread and job efficiency. The following is an example of a scraper load time study form. Numbers in the white columns are stop watch readings; numbers in the shaded columns are calculated:

Total Cycle Times (less delays)	Arrive Cut	Wait Time	Begin Load	Load Time	End Load	Begin Delay	Delay Time	End Delay
	0.00	0.30	0.30	0.60	0.90			
3.50	3.50	0.30	3.80	0.65	4.45			
4.00	7.50	0.35	7.85	0.70	8.55	9.95	1.00	10.95
4.00	12.50	0.42	12.92	0.68	13.60			

NOTE: All numbers are in minutes

This may be easily extended to include other segments of the cycle such as haul time, dump time, etc. Haul roads may be further segmented to more accurately define performance, including measured speed traps. Similar forms can be made for pushers, loaders, dozers, etc. *Wait Time* is the time a unit must wait for another unit so that the two can function together (haul unit waiting for pusher). *Delay Time* is any time, other than wait time, when a machine is not performing in the work cycle (scraper waiting to cross railroad track).

To determine trips-per-hour at 100% efficiency, divide 60 minutes by the average cycle time less all wait and delay time. Cycle time may or may not include wait and/or delay time. Therefore, it is possible to figure different kinds of production: measured production, production without wait or delay, maximum production, etc. For example:

Actual Production: includes all wait and delay time.

Normal Production (without delays): includes wait time that is considered normal, but no delay time.

Maximum Production: to figure maximum (or optimum) production, both wait time and delay time are eliminated. The cycle time may be further altered by using an optimum load time.

Example (English)

A job study of a Wheel Tractor-Scraper might yield the following information:

- Average wait time = 0.28 minute
- Average load time = 0.65
- Average delay time = 0.25
- Average haul time = 4.26
- Average dump time = 0.50
- Average return time = 2.09
- Average total cycle = 8.03 minutes
- Less wait & delay time = 0.53
- Average cycle 100% eff. = 7.50 minutes

Weight of haul unit empty — 48,650 lb

Weights of haul unit loaded —

- Weighing unit #1 — 93,420 lb
- Weighing unit #2 — 89,770 lb
- Weighing unit #3 — 88,760 lb

$$\frac{271,950 \text{ lb}}{\text{average}} = 90,650 \text{ lb}$$

1. Average load weight = 90,650 lb – 48,650 lb = 42,000 lb
2. Bank density = 3125 lb/BCY

$$\begin{aligned} 3. \text{ Load} &= \frac{\text{Weight of load}}{\text{Bank density}} \\ &= \frac{42,000 \text{ lb}}{3125 \text{ lb/BCY}} = 13.4 \text{ BCY} \end{aligned}$$

$$4. \text{ Cycles/hr} = \frac{60 \text{ min/hr}}{\text{Cycle time}} = \frac{60 \text{ min/hr}}{7.50 \text{ min/cycle}} = 80 \text{ cycles/hr}$$

$$\begin{aligned} 5. \text{ Production} &= \text{Load/cycle} \times \text{cycles/hr} \\ (\text{less delays}) &= 13.4 \text{ BCY/cycle} \times 8.0 \text{ cycles/hr} \\ &= 107.2 \text{ BCY/hr} \end{aligned}$$

Example (Metric)

A job study of a Wheel Tractor-Scraper might yield the following information:

Average wait time	= 0.28 minute
Average load time	= 0.65
Average delay time	= 0.25
Average haul time	= 4.26
Average dump time	= 0.50
Average return time	= 2.09
Average total cycle	= 8.03 minutes
Less wait & delay time	= 0.53
Average cycle 100% eff.	= 7.50 minutes

Weight of haul unit empty — 22 070 kg

Weights of haul unit loaded —

Weighing unit #1 —	42 375 kg
Weighing unit #2 —	40 720 kg
Weighing unit #3 —	40 260 kg
	123 355 kg;
	average = 41 120 kg

1. Average load weight = 41 120 kg – 22 070 kg = 19 050 kg
2. Bank density = 1854 kg/BCM
3. Load = $\frac{\text{Weight of load}}{\text{Bank density}}$
 $= \frac{19\,050\text{ kg}}{1854\text{ kg/BCM}} = 10.3\text{ BCM}$
4. Cycles/hr = $\frac{60\text{ min/hr}}{\text{Cycle time}} = \frac{60\text{ min/hr}}{7.50\text{ min/cycle}} = 80\text{ cycles/hr}$
5. Production = Load/cycle × cycles/hr
 (less delays) = 10.3 BCM/cycle × 8.0 cycles/hr
 = 82 BCM/hrr



NOTE: The Cat® Cycle Timer Program software uses laptop computers in place of stopwatches, organizes the data, and allows study results to be printed.

ESTIMATING PRODUCTION OFF-THE-JOB

It is often necessary to estimate production of earthmoving machines which will be selected for a job. As a guide, the remainder of the section is devoted to discussions of various factors that may affect production. Some of the figures have been rounded for easier calculation.

Rolling Resistance (RR) is a measure of the force that must be overcome to roll or pull a wheel over the ground. It is affected by ground conditions and load — the deeper a wheel sinks into the ground, the higher the rolling resistance. Internal friction and tire flexing also contribute to rolling resistance. Experience has shown that minimum resistance is 1%-1.5% (see Typical Rolling Resistance Factors in Tables section) of the gross machine weight (on tires). A 2% base resistance is quite often used for estimating. Resistance due to tire penetration is approximately 1.5% of the gross machine weight for each inch of tire penetration (0.6% for each cm of tire penetration). Thus rolling resistance can be calculated using these relationships in the following manner:

$$\text{RR} = 2\% \text{ of GMW} + 0.6\% \text{ of GMW per cm tire penetration}$$

$$\text{RR} = 2\% \text{ of GMW} + 1.5\% \text{ of GMW per inch tire penetration}$$

It's *not* necessary for the tires to actually penetrate the road surface for rolling resistance to increase above the minimum. If the road surface flexes under load, the effect is nearly the same — the tire is always running “uphill.” Only on very hard, smooth surfaces with a well compacted base will the rolling resistance approach the minimum.

When actual penetration takes place, some variation in rolling resistance can be noted with various inflation pressures and tread patterns.

NOTE: When figuring “pull” requirements for track-type tractors, rolling resistance applies only to the trailed unit's *weight on wheels*. Since track-type tractors utilize steel wheels moving on steel “roads,” a tractor's rolling resistance is relatively constant and is accounted for in the Drawbar Pull rating.

- Grade Resistance
- Total Resistance
- Traction

Grade Resistance is a measure of the force that must be overcome to move a machine over unfavorable grades (uphill). Grade assistance is a measure of the force that assists machine movement on favorable grades (downhill).

Grades are generally measured in percent slope, which is the ratio between vertical rise or fall and the horizontal distance in which the rise or fall occurs. For example, a 1% grade is equivalent to a 1 m (ft) rise or fall for every 100 m (ft) of horizontal distance; a rise of 4.6 m (15 ft) in 53.3 m (175 ft) equals an 8.6% grade.

$$\frac{4.6 \text{ m (rise)}}{53.3 \text{ m (horizontal distance)}} = 8.6\% \text{ grade}$$

$$\frac{15 \text{ ft (rise)}}{175 \text{ ft (horizontal distance)}} = 8.6\% \text{ grade}$$

Uphill grades are normally referred to as adverse grades and downhill grades as favorable grades. Grade resistance is usually expressed as a positive (+) percentage and grade assistance is expressed as a negative (–) percentage.

It has been found that for each 1% increment of adverse grade an additional 10 kg (20 lb) of resistance must be overcome for each metric (U.S.) ton of machine weight. This relationship is the basis for determining the Grade Resistance Factor which is expressed in kg/metric ton (lb/U.S. ton):

$$\begin{aligned} \text{Grade Resistance Factor} &= 10 \text{ kg/m ton} \times \% \text{ grade} \\ &= 20 \text{ lb/U.S. ton} \times \% \text{ grade} \end{aligned}$$

Grade resistance (assistance) is then obtained by multiplying the Grade Resistance Factor by the machine weight (GMW) in metric (U.S.) tons.

$$\text{Grade Resistance} = \text{GR Factor} \times \text{GMW in metric (U.S.) tons}$$

Grade resistance may also be calculated using percentage of gross weight. This method is based on the relationship that grade resistance is approximately equal to 1% of the gross machine weight for 1% of grade.

$$\text{Grade Resistance} = 1\% \text{ of GMW} \times \% \text{ grade}$$

Grade resistance (assistance) affects both wheel and track-type machines.

Total Resistance is the combined effect of rolling resistance (wheel vehicles) and grade resistance. It can be computed by summing the values of rolling resistance and grade resistance to give a resistance in kilogram (pounds) force.

$$\text{Total Resistance} = \text{Rolling Resistance} + \text{Grade Resistance}$$

Total resistance can also be represented as consisting completely of grade resistance expressed in percent grade. In other words, the rolling resistance component is viewed as a corresponding quantity of additional adverse grade resistance. Using this approach, total resistance can then be considered in terms of percent grade.

This can be done by converting the contribution of rolling resistance into a corresponding percentage of grade resistance. Since 1% of adverse grade offers a resistance of 10 kg (20 lb) for each metric or (U.S.) ton of machine weight, then each 10 kg (20 lb) of resistance per ton of machine weight can be represented as an additional 1% of adverse grade. Rolling resistance in percent grade and grade resistance in percent grade can then be summed to give Total Resistance in percent or Effective Grade. The following formulas are useful in arriving at Effective Grade.

$$\begin{aligned} \text{Rolling Resistance (\%)} &= 2\% + 0.6\% \text{ per cm tire penetration} \\ &= 2\% + 1.5\% \text{ per inch tire penetration} \end{aligned}$$

$$\begin{aligned} \text{Grade Resistance (\%)} &= \% \text{ grade} \\ \text{Effective Grade (\%)} &= \text{RR (\%)} + \text{GR (\%)} \end{aligned}$$

Effective grade is a useful concept when working with Rimpull-Speed-Gradeability curves, Retarder curves, Brake Performance curves, and Travel Time curves.

Traction — is the driving force developed by a wheel or track as it acts upon a surface. It is expressed as usable Drawbar Pull or Rimpull. The following factors affect traction: weight on the driving wheel or tracks, gripping action of the wheel or track, and ground conditions. The coefficient of traction (for any roadway) is the ratio of the maximum pull developed by the machine to the total weight on the drivers.

$$\text{Coeff. of traction} = \frac{\text{Pull}}{\text{weight on drivers}}$$

Therefore, to find the usable pull for a given machine:
Usable pull = Coeff. of traction × weight on drivers

Example: Track-Type Tractor

What usable drawbar pull (DBP) can a 26 800 kg (59,100 lb) Track-type Tractor exert while working on firm earth? on loose earth? (See table section for coefficient of traction.)

Answer:

Firm earth — Usable DBP =
 $0.90 \times 26\,800 \text{ kg} = 24\,120 \text{ kg}$
 $(0.90 \times 59,100 \text{ lb} = 53,190 \text{ lb})$
 Loose earth — Usable DBP =
 $0.60 \times 26\,800 \text{ kg} = 16\,080 \text{ kg}$
 $(0.60 \times 59,100 \text{ lb} = 35,460 \text{ lb})$

If a load required 21 800 kg (48,000 lb) pull to move it, this tractor could move the load on firm earth. However, if the earth were loose, the tracks would spin.

NOTE: D8R through D11R Tractors may attain higher coefficients of traction due to their suspended undercarriage.

Example: Wheel Tractor-Scraper

What usable rimpull can a 621F size machine exert while working on firm earth? on loose earth? The total loaded weight distribution of this unit is:

Drive unit	Scraper unit
wheels: 23 600 kg	wheels: 21 800 kg
(52,000 lb)	(48,000 lb)

Remember, use weight on drivers only.
 Answer:

Firm earth — $0.55 \times 23\,600 \text{ kg} = 12\,980 \text{ kg}$
 $(0.55 \times 52,000 \text{ lb} = 28,600 \text{ lb})$
 Loose earth — $0.45 \times 23\,600 \text{ kg} = 10\,620 \text{ kg}$
 $(0.45 \times 52,000 \text{ lb} = 23,400 \text{ lb})$

On firm earth this unit can exert up to 12 980 kg (28,600 lb) rimpull without excessive slipping. However, on loose earth the drivers would slip if more than 10 620 kg (23,400 lb) rimpull were developed.



Altitude — Specification sheets show how much pull a machine can produce for a given gear and speed when the engine is operating at rated horsepower. When a standard machine is operated in high altitudes, the engine may require derating to maintain normal engine life. This engine derating will produce less drawbar pull or rimpull.

The Tables Section gives the altitude deration in percent of flywheel horsepower for current machines. It should be noted that some turbocharged engines can operate up to 4570 m (15,000 ft) before they require derating. Most machines are engineered to operate up to 1500-2290 m (5000-7500 ft) before they require deration.

The horsepower deration due to altitude must be considered in any job estimating. The amount of power deration will be reflected in the machine's gradeability and in the load, travel, and dump and load times (unless loading is independent of the machine itself). Altitude may also reduce retarding performance. Consult a Cat representative to determine if deration is applicable. Fuel grade (heat content) can have a similar effect of derating engine performance.

The example job problem that follows indicates one method of accounting for altitude deration: by increasing the appropriate components of the total cycle time by a percentage equal to the percent of horsepower deration due to altitude. (i.e., if the travel time of a hauling unit is determined to be 1.00 minute at full HP, the time for the same machine derated to 90% of full HP will be 1.10 min.) This is an approximate method that yields reasonably accurate estimates up to 3000 m (10,000 feet) elevation.

Travel time for hauling units derated more than 10% should be calculated as follows using Rimpull-Speed-Gradeability charts.

1) Determine total resistance (grade plus rolling) in percent.

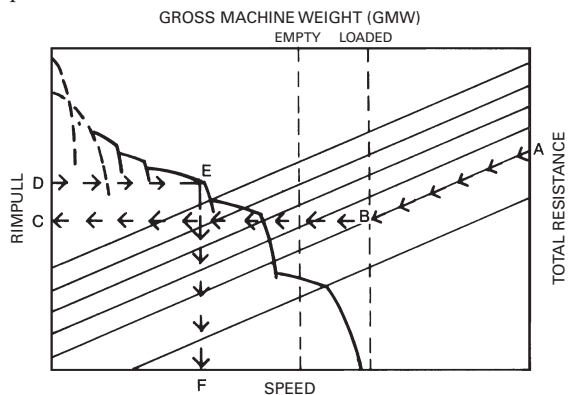

2) Beginning at point A on the chart follow the total resistance line diagonally to its intersection, B, with the vertical line corresponding to the appropriate gross machine weight. (Rated loaded and empty GMW lines are shown dotted.)

3) Using a straight-edge, establish a horizontal line to the left from point B to point C on the rim-pull scale.

4) Divide the value of point C as read on the rim-pull scale by the percent of total horsepower available after altitude deration from the Tables Section. This yields rimpull value D higher than point C.

- Job Efficiency
- Example Problem (English)

5) Establish a horizontal line right from point D. The farthest right intersection of this line with a curved speed range line is point E.

6) A vertical line down from point E determines point F on the speed scale.

7) Multiply speed in kmh by 16.7 (mph by 88) to obtain speed in m/min (ft/min). Travel time in minutes for a given distance in feet is determined by the formula:

$$\text{Time (min)} = \frac{\text{Distance in m (ft)}}{\text{Speed in m/min (ft/min)}}$$

The *Travel Time Graphs* in sections on Wheel Tractor-Scrapers and Construction & Mining Trucks can be used as an alternative method of calculating haul and/or return times.



The following example provides a method to manually estimate production and cost. Today, computer programs, such as Caterpillar's Fleet Production and Cost Analysis (FPC), provide a much faster and more accurate means to obtain those application results.

Example problem (English)

A contractor is planning to put the following spread on a dam job. What is the estimated production and cost/BCY?

Equipment:

- 11 — 631G Wheel Tractor-Scrapers
- 2 — D9T Tractors with C-dozers
- 2 — 12H Motor Graders
- 1 — 825G Tamping Foot Compactor

Material:

- Description — Sandy clay; damp, natural bed
- Bank Density — 3000 lb/BCY
- Load Factor — 0.80
- Shrinkage Factor — 0.85
- Traction Factor — 0.50
- Altitude — 7500 ft

Job Layout — Haul and Return:

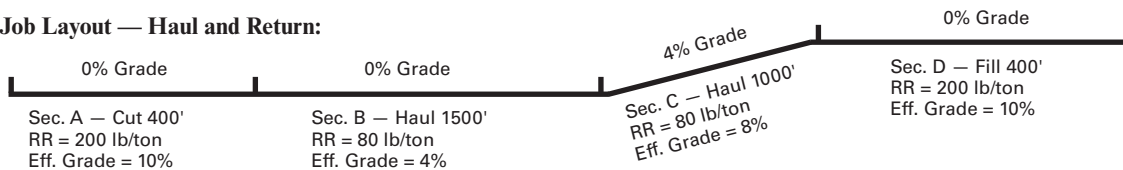

Total Effective Grade = RR (%) ± GR (%)

Sec. A: Total Effective Grade = 10% + 0% = 10%

Sec. B: Total Effective Grade = 4% + 0% = 4%

Sec. C: Total Effective Grade = 4% + 4% = 8%

Sec. D: Total Effective Grade = 10% + 0% = 10%

Job Efficiency is one of the most complex elements of estimating production since it is influenced by factors such as operator skill, minor repairs and adjustments, personnel delays, and delays caused by job layout. An approximation of efficiency, if no job data is available, is given below.

Operation	Working Hour	Efficiency Factor
Day	50 min/hr	0.83
Night	45 min/hr	0.75

These factors do not account for delays due to weather or machine downtime for maintenance and repairs. You must account for such factors based on experience and local conditions.

1. Estimate Payload:

Est. load (LCY) × L.F. × Bank Density = payload
 31 LCY × 0.80 × 3000 lb/BCY = 74,400 lb payload

2. Establish Machine Weight:

Empty Wt. — 102,460 lb or 51.27 tons
 Wt. of Load — 74,400 lb or 37.2 tons
 Total (GMW) — 176,860 lb or 88.4 tons

3. Calculate Usable Pull (traction limitation):

Loaded: (weight on driving wheels = 54%) (GMW)

Traction Factor × Wt. on driving wheels =
 0.50 × 176,860 lb × 54% = 47,628 lb

Empty: (weight on driving wheels = 69%) (GMW)

Traction Factor × Wt. on driving wheels =
 0.50 × 102,460 lb × 69% = 35,394 lb

4. Derate for Altitude:

Check power available at 7500 ft from altitude deration table in the Tables Section.

631G — 100% 12H — 83%
 D9T — 100% 825G — 100%

Then adjust if necessary:

Load Time — controlled by D9T, at 100% power, no change.

Travel, Maneuver and Spread time — 631G, no change.

5. Compare Total Resistance to Tractive Effort on haul:

Grade Resistance —

GR = lb/ton × tons × adverse grade in percent
 Sec. C: = 20 lb/ton × 88.4 tons × 4% grade = 7072 lb

Rolling Resistance —

RR = RR Factor (lb/ton) × GMW (tons)
 Sec. A: = 200 lb/ton × 88.4 tons = 17,686 lb
 Sec. B: = 80 lb/ton × 88.4 tons = 7072 lb
 Sec. C: = 80 lb/ton × 88.4 tons = 7072 lb
 Sec. D: = 200 lb/ton × 88.4 tons = 17,686 lb

Total Resistance —

TR = RR + GR
 Sec. A: = 17,686 lb + 0 = 17,686 lb
 Sec. B: = 7072 lb + 0 = 7072 lb
 Sec. C: = 7072 lb + 6496 lb = 14,144 lb
 Sec. D: = 17,686 lb + 0 = 17,686 lb

Check usable pounds pull against maximum pounds pull required to move the 631G.

Pull usable ... 47,628 lb loaded

Pull required ... 17,686 lb maximum total resistance

Estimate travel time for haul from 631G (loaded) travel time curve; read travel time from distance and effective grade.

Travel time (from curves):

Sec. A: 0.60 min
 Sec. B: 1.00
 Sec. C: 1.20
 Sec. D: 0.60
 3.40 min

NOTE: This is an estimate only; it *does not account for all the acceleration and deceleration time*, therefore it is not as accurate as the information obtained from a computer program.

6. Compare Total Resistance to Tractive Effort on return:

Grade Assistance —

GA = 20 lb/ton × tons × negative grade in percent
 Sec. C: = 20 lb/ton × 51.2 tons × 4% grade = 4096 lb

Rolling Resistance —

RR = RR Factor × Empty Wt (tons)
 Sec. D: = 200 lb/ton × 51.2 tons = 10,240 lb
 Sec. C: = 80 lb/ton × 51.2 tons = 4091 lb
 Sec. B: = 80 lb/ton × 51.2 tons = 4091 lb
 Sec. A: = 200 lb/ton × 51.2 tons = 10,240 lb

Total Resistance —

TR = RR + GA
 Sec. D: = 10,240 lb + 0 = 10,240 lb
 Sec. C: = 4096 lb + 4096 lb = 8192 lb
 Sec. B: = 4096 lb + 0 = 4096 lb
 Sec. A: = 10,240 lb + 0 = 10,240 lb

Check usable pounds pull against maximum pounds pull required to move the 631G.

Pounds pull usable ... 35,349 lb empty

Pounds pull required ... 10,240 lb

Estimate travel time for return from 631G empty travel time curve.

Travel time (from curves):

Sec. A: 0.40 min
 Sec. B: 0.55
 Sec. C: 0.80
 Sec. D: 0.40
 2.15 min

7. Estimate Cycle Time:

Total Travel Time (Haul plus Return) = 5.55 min
 Adjusted for altitude: 100% × 5.55 min = 5.55 min
 Load Time 0.7 min
 Maneuver and Spread Time 0.7 min
 Total Cycle Time 6.95 min

8. Check pusher-scraper combinations:

Pusher cycle time consists of load, boost, return and maneuver time. Where actual job data is not available, the following may be used.

Boost time = 0.10 minute
 Return time = 40% of load time
 Maneuver time = 0.15 minute
 Pusher cycle time = 140% of load time + 0.25 minute
 Pusher cycle time = 140% of 0.7 min + 0.25 minute
 = 0.98 + 0.25 = 1.23 minute

Scraper cycle time divided by pusher cycle time indicates the number of scrapers which can be handled by each pusher.

$$\frac{6.95 \text{ min}}{1.23 \text{ min}} = 5.65$$

- Example Problem (English)
- Example Problem (Metric)

Each push tractor is capable of handling five plus scrapers. Therefore the two pushers can adequately serve the eleven scrapers.

9. Estimate Production:

Cycles/hour = $60 \text{ min} \div \text{Total cycle time}$
 = $60 \text{ min/hr} \div 6.95 \text{ min/cycle}$
 = 8.6 cycles/hr

Estimated load = Heaped capacity \times L.F.
 = $31 \text{ LCY} \times 0.80$
 = 24.8 BCY

Hourly unit production = Est. load \times cycles/hr
 = $24.8 \text{ BCY} \times 8.6 \text{ cycles/hr}$
 = 213 BCY/hr

Adjusted production = Efficiency factor \times hourly production
 = $0.83 (50 \text{ min hour}) \times 213 \text{ BCY}$
 = 177 BCY/hr

Hourly fleet production = Unit production \times No. of units
 = $177 \text{ BCY/hr} \times 11$
 = 1947 BCY/hr

10. Estimate Compaction:

Compaction requirement = S.F. \times hourly fleet production
 = $0.85 \times 1947 \text{ BCY/hr}$
 = 1655 CCY/hr

Compaction capability (given the following):

- Compacting width, 7.4 ft (W)
- Average compacting speed, 6 mph (S)
- Compacted lift thickness, 7 in (L)
- No. of passes required, 3 (P)

825G production =

$$\text{CCY/hr} = \frac{W \times S \times L \times 16.3}{P} \text{ (conversion constant)}$$

$$= \frac{7.4 \times 6 \times 7 \times 16.3}{3}$$

$$= 1688 \text{ CCY/hr}$$

Given the compaction requirement of 1655 CCY/hr, the 825G is an adequate compactor match-up for the rest of the fleet. However, any change to job layout that would increase fleet production would upset this balance.

11. Estimate Total Hourly Cost:

631G	@ \$65.00/hr \times 11 units	\$715.00
D9T	@ 75.00/hr \times 2 units	150.00
12H	@ 15.00/hr \times 2 units	30.00
825G	@ 40.00/hr \times 1 unit	40.00
Operators	@ 20.00/hr \times 16 men	320.00
Total Hourly Owning and Operating Cost		\$1,255.00

12. Calculate Performance:

$$\text{Cost per BCY} = \frac{\text{Total cost/hr}}{\text{Production/hr}}$$

$$= \frac{\$1,255.00}{1947 \text{ BCY/hr}}$$

$$= 64¢ \text{ BCY}$$

NOTE: Ton-MPH calculations should be made to judge the ability of the tractor-scraper tires to operate safely under these conditions.

13. Other Considerations:

If other equipment such as rippers, water wagons, discs or other miscellaneous machines are needed for the particular operation, then these machines must also be included in the cost per BCY.



Example problem (Metric)

A contractor is planning to put the following spread on a dam job. What is the estimated production and cost/BCM?

Equipment:

- 11 — 631G Wheel Tractor-Scrapers
- 2 — D9T Tractors with C-dozers
- 2 — 12H Motor Graders
- 1 — 825G Tamping Foot Compactor

Material:

- Description — Sandy clay; damp, natural bed
- Bank Density — 1770 kg/BCM
- Load Factor — 0.80
- Shrinkage Factor — 0.85
- Traction Factor — 0.50
- Altitude — 2300 meters

Job Layout — Haul and Return:

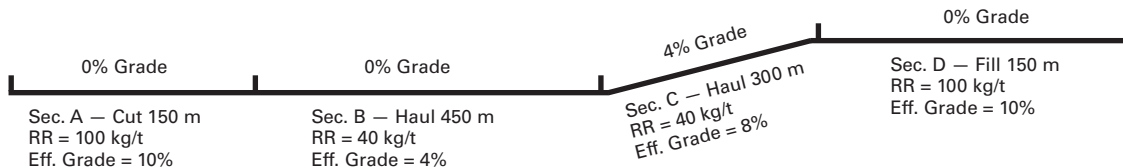

Total Effective Grade = RR (%) ± GR (%)

Sec. A: Total Effective Grade = 10% + 0% = 10%

Sec. B: Total Effective Grade = 4% + 0% = 4%

Sec. C: Total Effective Grade = 4% + 4% = 8%

Sec. D: Total Effective Grade = 10% + 0% = 10%

1. Estimate Payload:

Est. load (LCM) × L.F. × Bank Density = payload
 24 LCM × 0.80 × 1770 kg/BCM = 34 000 kg payload

2. Machine Weight:

Empty Wt. — 46 475 kg or 46.48 metric tons
 Wt. of Load — 34 000 kg or 34 metric tons
 Total (GMW) — 80 475 kg or 80.48 metric tons

3. Calculate Usable Pull (traction limitation):

Loaded: (weight on driving wheels = 54%) (GMW)

Traction Factor × Wt. on driving wheels =
 0.50 × 80 475 kg × 54% = 21 728 kg

Empty: (weight on driving wheels = 69%) (GMW)

Traction Factor × Wt. on driving wheels =
 0.50 × 46 475 kg × 69% = 16 034 kg

4. Derate for Altitude:

Check power available at 2300 m from altitude deration table in the Tables Section.

631G — 100% 12H — 83%
 D9T — 100% 825G — 100%

Then adjust if necessary:

Load Time — controlled by D9T, at 100% power, no change.

Travel, Maneuver and Spread time — 631G, no change.

5. Compare Total Resistance to Tractive Effort on haul:

Grade Resistance —

GR = 10 kg/metric ton × tons × adverse grade
 in percent

Sec. C: = 10 kg/metric ton × 80.48 metric tons × 4%
 grade = 3219 kg

Rolling Resistance —

RR = RR Factor (kg/mton) × GMW (metric tons)

Sec. A: = 100 kg/metric ton × 80.48 metric tons
 = 8048 kg

Sec. B: = 40 kg/metric ton × 80.48 metric tons
 = 3219 kg

Sec. C: = 40 kg/metric ton × 80.48 metric tons
 = 3219 kg

Sec. D: = 100 kg/metric ton × 80.48 metric tons
 = 8048 kg

Total Resistance —

TR = RR + GR

Sec. A: = 8048 kg + 0 = 8048 kg

Sec. B: = 3219 kg + 0 = 3219 kg

Sec. C: = 3219 kg + 3219 kg = 6438 kg

Sec. D: = 8048 kg + 0 = 8048 kg

Check usable kilogram force against maximum kilogram force required to move the 631G.

Force usable ... 21 728 kg loaded

Force required ... 8048 kg maximum total resistance

Estimate travel time for haul from 631G (loaded) travel time curve; read travel time from distance and effective grade.

Travel time (from curves):

Sec. A: 0.60 min

Sec. B: 1.00

Sec. C: 1.20

Sec. D: 0.60

3.40 min

NOTE: This is an estimate only; it *does not account for all the acceleration and deceleration time*, therefore it is not as accurate as the information obtained from a computer program.

6. Compare Total Resistance to Tractive Effort on return:

Grade Assistance —

GA = 10 kg/mton × metric tons × negative grade
 in percent

Sec. C: = 10 kg/metric ton × 46.48 metric tons
 × 4% grade = 1859 kg

Rolling Resistance —

$$RR = RR \text{ Factor} \times \text{Empty Wt.}$$

$$\begin{aligned} \text{Sec. D:} &= 100 \text{ kg/metric ton} \times 46.48 \text{ metric tons} \\ &= 4648 \text{ kg} \\ \text{Sec. C:} &= 40 \text{ kg/metric ton} \times 46.48 \text{ metric tons} \\ &= 1859 \text{ kg} \\ \text{Sec. B:} &= 40 \text{ kg/metric ton} \times 46.48 \text{ metric tons} \\ &= 1859 \text{ kg} \\ \text{Sec. A:} &= 100 \text{ kg/metric ton} \times 46.48 \text{ metric tons} \\ &= 4648 \text{ kg} \end{aligned}$$

Total Resistance —

$$TR = RR - GA$$

$$\begin{aligned} \text{Sec. D:} &= 4648 \text{ kg} - 0 = 4648 \text{ kg} \\ \text{Sec. C:} &= 1859 \text{ kg} - 1859 \text{ kg} = 0 \\ \text{Sec. B:} &= 1859 \text{ kg} - 0 = 1859 \text{ kg} \\ \text{Sec. A:} &= 4648 \text{ kg} - 0 = 4648 \text{ kg} \end{aligned}$$

Check usable kilogram force against maximum force required to move the 631G.

Kilogram force usable ... 16 034 kg empty

Kilogram force required ... 4645 kg

Estimate travel time for return from 631G empty travel time curve.

Travel time (from curves):

$$\begin{aligned} \text{Sec. A:} &0.40 \text{ min} \\ \text{Sec. B:} &0.55 \\ \text{Sec. C:} &0.80 \\ \text{Sec. D:} &0.40 \\ \hline &2.15 \text{ min} \end{aligned}$$

7. Estimate Cycle Time:

$$\begin{aligned} \text{Total Travel Time (Haul plus Return)} &= 5.55 \text{ min} \\ \text{Adjusted for altitude: } 100\% \times 5.55 \text{ min} &= 5.55 \text{ min} \\ \text{Load Time} &0.7 \text{ min} \\ \text{Maneuver and Spread Time} &0.7 \text{ min} \\ \hline \text{Total Cycle Time} &6.95 \text{ min} \end{aligned}$$

8. Check pusher-scraper combinations:

Pusher cycle time consists of load, boost, return and maneuver time. Where actual job data is not available, the following may be used.

$$\begin{aligned} \text{Boost time} &= 0.10 \text{ minute} \\ \text{Return time} &= 40\% \text{ of load time} \\ \text{Maneuver time} &= 0.15 \text{ minute} \\ \text{Pusher cycle time} &= 140\% \text{ of load time} + 0.25 \text{ minute} \\ \text{Pusher cycle time} &= 140\% \text{ of } 0.7 \text{ min} + 0.25 \text{ minute} \\ &= 0.98 + 0.25 = 1.23 \text{ minute} \end{aligned}$$

Scraper cycle time divided by pusher cycle time indicates the number of scrapers which can be handled by each pusher.

$$\frac{6.95 \text{ min}}{1.23 \text{ min}} = 5.65$$

Each push tractor is capable of handling five plus scrapers. Therefore the two pushers can adequately serve the eleven scrapers.

9. Estimate Production:

$$\begin{aligned} \text{Cycles/hour} &= 60 \text{ min} \div \text{Total cycle time} \\ &= 60 \text{ min/hr} \div 6.95 \text{ min/cycle} \\ &= 8.6 \text{ cycles/hr} \\ \text{Estimated load} &= \text{Heaped capacity} \times \text{L.F.} \\ &= 24 \text{ LCM} \times 0.80 \\ &= 19.2 \text{ BCM} \\ \text{Hourly unit production} &= \text{Est. load} \times \text{cycles/hr} \\ &= 19.2 \text{ BCM} \times 8.6 \text{ cycles/hr} \\ &= 165 \text{ BCM} \\ \text{Adjusted production} &= \text{Efficiency factor} \times \text{hourly production} \\ &= 0.83 (50 \text{ min hour}) \times 165 \text{ BCM} \\ &= 137 \text{ BCM/hour} \\ \text{Hourly fleet production} &= \text{Unit production} \times \text{No. of units} \\ &= 137 \text{ BCM/hr} \times 11 \text{ units} \\ &= 1507 \text{ BCM/hr} \end{aligned}$$

10. Estimate Compaction:

$$\begin{aligned} \text{Compaction requirement} &= \text{S.F.} \times \text{hourly fleet production} \\ &= 0.85 \times 1507 \text{ BCM/hr} \\ &= 1280 \text{ CCM/hr} \end{aligned}$$

Compaction capability (given the following):

$$\begin{aligned} \text{Compacting width, } 2.26 \text{ m} & \quad (W) \\ \text{Average compacting speed, } 9.6 \text{ km/h} & \quad (S) \\ \text{Compacted lift thickness, } 18 \text{ cm} & \quad (L) \\ \text{No. of passes required, } 3 & \quad (P) \end{aligned}$$

825G production =

$$\begin{aligned} \text{CCY/hr} &= \frac{W \times S \times L \times 10}{P} \quad (\text{conversion factor}) \\ &= \frac{2.26 \times 9.6 \times 18 \times 10}{3} \\ &= 1302 \end{aligned}$$

Given the compaction requirement of 1280 CCM/h, the 825G is an adequate compactor match-up for the rest of the fleet. However, any change to job layout that would increase fleet production would upset this balance.

Estimating Production Off-the-Job

- Example Problem (Metric)
- Economic Haul Distances

11. Estimate Total Hourly Cost:

631G	@ \$65.00/hr × 11 units	\$715.00
D9T	@ 75.00/hr × 2 units	150.00
12H	@ 15.00/hr × 2 units	30.00
825G	@ 40.00/hr × 1 unit	40.00
Operators	@ 20.00/hr × 16 men	320.00
Total Hourly Owning and Operating Cost		\$1,255.00

12. Calculate Performance:

$$\begin{aligned}
 \text{Cost per BCM} &= \frac{\text{Total cost/hr}}{\text{Production/hr}} \\
 &= \frac{\$1,255.00}{1507 \text{ BCM/hr}} \\
 &= 83\text{¢/BCM}
 \end{aligned}$$

NOTE: Ton-km/h calculations should be made to judge the ability of the tractor-scraper tires to operate safely under these conditions.

13. Other Considerations:

If other equipment such as rippers, water wagons, discs or other miscellaneous machines are needed for the particular operation, then these machines must also be included in the cost per BCM.

SOFTWARE NOTE: The Cat DOZSIM program can provide a valuable tool for production dozing applications. Motor Grader Calculator can be used to determine the number of graders required to maintain haul roads, given a set of site parameters and FPC and or VET will help to estimate production levels.

SYSTEMS

Caterpillar offers a variety of machines for different applications and jobs. Many of these separate machines function together in mining and earthmoving systems.

- Bulldozing with track-type tractors
- Load-and-Carry with wheel loaders
- Scrapers self-loading, elevator, auger, or push-pull configurations, or push-loaded by track-type tractors
- Articulated trucks loaded by excavators, track loaders or wheel loaders
- Off-highway trucks loaded by shovels, excavators or wheel loaders

Haul System Selection: In selecting a hauling system for a project, there may seem to be more than one “right” choice. Many systems may meet the distance, ground conditions, grade, material type, and production rate requirements. After considering all of the different factors, one hauling system usually provides better performance and better potential for lowest cost per ton or BCY/BCM. This makes it critical for the dealer and customer to work together to get accurate information for their operation or project. Caterpillar is committed to providing the correct earthmoving system to match the customer’s specific needs.



GENERAL LOADED HAUL DISTANCES FOR MOBILE SYSTEMS

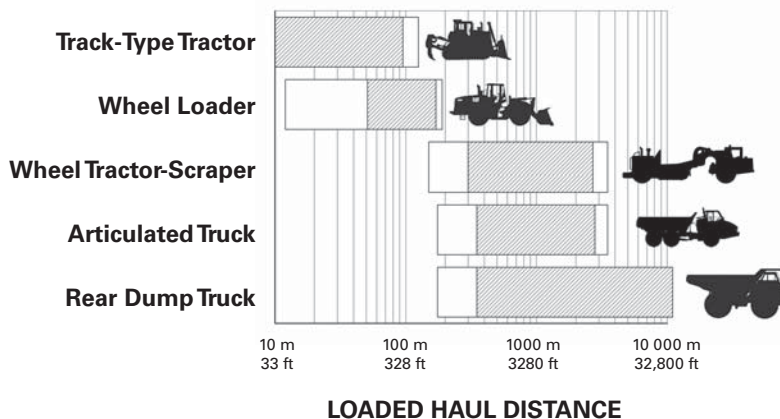

PRODUCTION ESTIMATING

Loading Match — Loading tools have a production range that varies with material, bucket configuration, target size, operator skill and load area conditions. The loader/truck matches given in the following table are with the typical number of passes and production range.

Your Cat dealer can provide advice and estimates based on your specific conditions.

Cat Earthmoving and Mining Systems Production/50 Min. Hr.

Please refer to the individual machine section for production targets.

FUEL CONSUMPTION AND PRODUCTIVITY

Fuel efficiency is the term used to relate fuel consumption and machine productivity. It is expressed in units of material moved per volume of fuel consumed. Common units are cubic meters or tonnes per liter of fuel (cubic yards or tons/gal). Determining fuel efficiency requires measuring both fuel consumption and production.

Measuring fuel consumption involves tapping into the vehicle's fuel supply system — without contaminating the fuel. The amount of fuel consumed during operation is then measured on a weight or volumetric basis and correlated with the amount of work the machine has done. Cat machines equipped with VIMS™ system can record fuel consumed with relative accuracy, given the engine is performing close to specifications.

Cat Aggregate Systems Production/50 Min. Hr.

Please refer to the individual machine section for production targets.

FORMULAS AND RULES OF THUMB

$$\text{Production, hourly} = \text{Load (BCM)/cycle} \times \frac{\text{cycles/hr}}{\text{cycles/hr}}$$

$$= \text{Load (BCY)/cycle} \times \frac{\text{cycles/hr}}{\text{cycles/hr}}$$

$$\text{Load Factor (L.F.)} = \frac{100\%}{100\% + \% \text{ swell}}$$

$$\text{Load (bank measure)} = \text{Loose cubic meters (LCM)} \times \text{L.F.}$$

$$= \text{Loose cubic yards (LCY)} \times \text{L.F.}$$

$$\text{Shrinkage Factor (S.F.)} = \frac{\text{Compacted cubic meters (or yards)}}{\text{Bank cubic meters (or yards)}}$$

$$\text{Density} = \text{Weight/Unit Volume}$$

$$\text{Load (bank measure)} = \frac{\text{Weight of load}}{\text{Bank density}}$$

$$\text{Rolling Resistance Factor}$$

$$= 20 \text{ kg/t} + (6 \text{ kg/t/cm} \times \text{cm})$$

$$= 40 \text{ lb/ton} + (30 \text{ lb/ton/inch} \times \text{inches})$$

$$\text{Rolling Resistance}$$

$$= \text{RR Factor (kg/t)} \times \text{GMW (tons)}$$

$$= \text{RR Factor (lb/ton)} \times \text{GMW (tons)}$$

$$\text{Rolling Resistance (general estimation)}$$

$$= 2\% \text{ of GMW} + 0.6\% \text{ of GMW per cm tire penetration}$$

$$= 2\% \text{ of GMW} + 1.5\% \text{ of GMW per inch tire penetration}$$

$$\% \text{ Grade} = \frac{\text{vertical change in elevation (rise)}}{\text{corresponding horizontal distance (run)}}$$

$$\text{Grade Resistance Factor} = 10 \text{ kg/m ton} \times \% \text{ grade}$$

$$= 20 \text{ lb/ton} \times \% \text{ grade}$$

$$\text{Grade Resistance} = \text{GR Factor (kg/t)} \times \text{GMW (tons)}$$

$$= \text{GR Factor (lb/ton)} \times \text{GMW (tons)}$$

$$\text{Grade Resistance} = 1\% \text{ of GMW} \times \% \text{ grade}$$

Total Resistance

$$= \text{Rolling Resistance (kg or lb)} + \text{Grade Resistance (kg or lb)}$$

$$\text{Total Effective Grade (\%)} = \text{RR (\%)} + \text{GR (\%)}$$

Usable pull (traction limitation)

$$= \text{Coeff. of traction} \times \text{weight on drivers}$$

$$= \text{Coeff. of traction} \times (\text{Total weight} \times \% \text{ on drivers})$$

$$\text{Pull required} = \text{Rolling Resistance} + \text{Grade Resistance}$$

$$= \text{Total Resistance}$$

$$\text{Total Cycle Time} = \text{Fixed time} + \text{Variable time}$$

Fixed time: See respective machine production section.

$$\text{Variable time} = \text{Total haul time} + \text{Total return time}$$

$$\text{Travel Time} = \frac{\text{Distance (m)}}{\text{Speed (m/min)}}$$

$$= \frac{\text{Distance (ft)}}{\text{Speed (fpm)}}$$

$$\text{Cycles per hour} = \frac{60 \text{ min/hr}}{\text{Total cycle time (min/cycle)}}$$

$$\text{Adjusted production} = \text{Hourly production} \times \text{Efficiency factor}$$

$$\text{No. of units required} = \frac{\text{Hourly production required}}{\text{Unit hourly production}}$$

$$\text{No. of scrapers a pusher will load} = \frac{\text{Scraper cycle time}}{\text{Pusher cycle time}}$$

$$\text{Pusher cycle time (min)} = 1.40 \text{ Load time (min)} + 0.25 \text{ min}$$

$$\text{Grade Horsepower} = \frac{\text{GMW (kg)} \times \text{Total Effective Grade} \times \text{Speed (km/h)}}{273.75}$$

$$= \frac{\text{GMW (lb)} \times \text{Total Effective Grade} \times \text{Speed (mph)}}{375}$$

STOCKPILE COAL HANDLING

CONTENTS

Introduction	29-1
Machine Selection	29-1
How to Equip	29-2
Production Factors	29-2
Estimating Hourly Production	29-3
Track-Type Tractors	29-4
Wheel Dozers	29-5
Wheel Loaders	29-7
Wheel Tractor-Scrapers	29-8
Example Problem	29-9

INTRODUCTION

Efficient methods have been developed for handling and storing coal with mobile equipment. Generally, a power plant or other industrial facility which uses coal, meets its daily requirements with incoming coal shipments and will maintain an emergency stockpile or deadpile. The deadpile is designed to meet the burn requirements during any interruption of coal shipments. Interruptions may include inclement weather, carrier strikes, scheduling problems, etc.

The deadpile will contain approximately a 90 day supply of coal and is constructed by thoroughly compacting lifts, or layers, of coal approximately 15 cm (6 in) thick. Thorough compaction of the entire stockpile, including the sides, eliminates air spaces, reducing the possibility of spontaneous combustion.

Reclaiming the deadpiled coal is critical when incoming shipments are not able to satisfy the burn requirements. Four basic types of mobile equipment are available for stockpiling and reclaiming coal — track-type tractors, wheel dozers, wheel loaders, and wheel tractor-scrappers. Each type has its own specific advantages. The equipment selected must be able to meet the maximum hourly burn rate.

MACHINE SELECTION

Track-Type Tractors

Track-type tractors continue to be the most widely used machines for coal handling operations. Equipped with a U-shaped coal dozer, they are suitable for meeting high production requirements over dozing distances of

less than 152 m (500 ft). Their tractive capabilities and gradeability permit them to operate on the sides of the stockpile and surge pile which often prove inaccessible to other types of equipment. They can also remove snow and frost penetrated coal from the stockpile surface so that rubber-tired equipment can work efficiently.

Wheel Dozers

These machines, with their long wheel base, low center of gravity, and articulated design, offer good stability and maneuverability. They have the ability to travel at a higher speed than the track-type tractor, moving easily from one area of operation to another, and provide greater compactive effort with fewer passes. They are capable of performing some utility functions. However, their coefficient of traction is less than that of track-type tractors. The most efficient dozing distance for the wheel dozers is usually less than 152 m (500 ft).

Coal scoop attachments are available for wheel dozers and can provide improved production due to the higher volume of the scoop.

Wheel Loaders

As dozing and hauling distances increase, wheel loaders are able to effectively move coal in load-and-carry operations. Since coal is a relatively light material, the loaders should be equipped with larger buckets sized for coal density. Versatility and mobility allow them to perform a variety of tasks, both on and off the stockpile. They can load trucks or railcars, dig out bottom ash and boiler slag from the ash storage areas, and move railcars within the vicinity of the power plant. Generally wheel loaders are more efficient than track or wheel dozers at distances of 122 m (400 ft) or more.

Coal Bowl Wheel Tractor-Scrapers

Coal Bowl Wheel Tractor-Scrapers are typically used for building and maintaining coal stockpiles and hauling coal to the supply system at coal power plants. The self-loading capability, large capacity, coal pile compaction, and haul speed of Coal Bowl Wheel Tractor-Scrapers make them the tool of choice for moving coal both short and long distances. Coal Bowl Wheel Tractor-Scrapers are available in the 637K and 657G twin engine models. Please reference section 24 of this handbook for more information on Coal Bowl Wheel Tractor-Scrapers.

HOWTO EQUIP

Counterweighting

While larger blades or buckets allow for greater production, counterweighting is often necessary to improve the machine’s balance and handling capability. For track-type tractors, a rear counterweight is recommended. Wheel machines use various methods to add weight. For example, scoop dozers use front counterweights, and wheel machines often use tire ballast. Below is a weight comparison of the Cat® standard U-Blade to the Coal U-Blade, along with the recommended counterweight for D11T, D10T2, D9T, D8T, and 834K.

**COAL STOCKPILE BLADE WEIGHT COMPARISON/
COUNTERWEIGHTING**

Model	U-Blade		Coal U-Blade/ Scoop		Counterweight	
	kg	lb	kg	lb	kg	lb
D11T	12 880	28,396	11 475	25,298	4989	11,000
D10T2	7918	17,456	7100	15,653	2928	6456
D9T	5634	12,421	4650	10,252	3142	6926
D8T	2825	6228	3200	7050	2749	6060
834K	2994	6600	3630	8000	75% CaCl ₂ in all tires —	
*834K with Scoop			8700	19,180	5360	11,816

Weights include blade or scoop only. The change in machine weight is determined by adding or subtracting the difference between the two blades. Counterweight or ballast may also need to be considered.

Track Shoe Width

Track shoes are an important consideration since shoe width determines tractive capability and compaction. Depending on the coal being stockpiled, the utility company will often have a strong preference concerning track shoe width. Basically, utilities stockpiling low rank or sub-bituminous rank lignite coal usually prefer the standard shoe width for maximum compactive effort to reduce the possibility of spontaneous combustion.

Utilities burning medium or high rank bituminous coals are not as concerned with spontaneous combustion and sometimes prefer a wider shoe that allows increased tractive capability on loose or less densely compacted coal stockpiles.

Tires

Many utility companies have established a tire preference for wheel machines. Normally a radial tire allows for the maximum tire print in the stockpile surface providing the best traction.

Other

The 834K’s performance may be improved in the varying underfoot conditions of a coal stockpile with the use of a Detroit NoSPIN differential. This differential provides added tractive capability on all coal piles, particularly loose coal.

PRODUCTION FACTORS

1. *The effect of grade* — dozer production will increase 3% for each 1% of favorable grade and decrease 2% for each 1% of adverse grade up to grades of 10%. The graph below exemplifies this point.

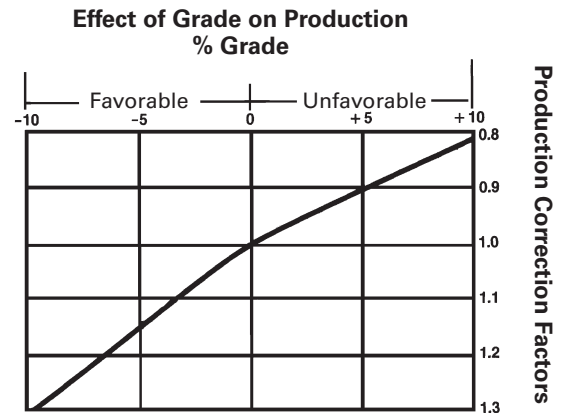

As a rule of thumb, track-type tractors can negotiate grades of about 60% in loose coal. Wheel dozers can negotiate grades up to 25% on fairly well compacted coal.

2. *Slot dozing*, which consists of dozing repeatedly in the same tracks, will increase production. The deeper the slot, the greater the increase in production. Obviously this will disrupt the surface of the pile; however it does provide maximum production.

Slot Condition	Slot Depth	Increase in Production
Slight	60 cm ~ 2 ft	10%
Consistent	60 cm-1.5 m ~ 2-5 ft	25%
Very Consistent	Over 1.5 m ~ Over 5 ft	30% +

3. *Relative traction* — machines will provide greater tractive effort as the compaction beneath them increases.

Condition	Machine	Coefficient of Traction
Well Compacted Coal	Track-type	*0.75-0.80
	Wheel	0.40-0.50
Loose Coal	Track-type	*0.60
	Wheel	0.30-0.40

*D11T, D10T2, D9T and D8T will often achieve a higher coefficient of traction due to their suspended undercarriage.

4. *Rolling Resistance* of rubber tired equipment will decrease as the compaction of the coal beneath the machines increases. Here are total rolling resistances on various surfaces.

	kg/Metric Ton	lb/U.S. Ton
● Main travel area from loading area to stockpile traveled and maintained.	29	65
● Travel over the compacted deadpile.	36	80
● Travel over thin lifts of uncompacted coal on the deadpile.	54	120
● Travel on loose piles under stacking conveyor or on a windrow.	90-136	200-300

5. *The degree of compaction required* — for medium and high rank bituminous coal, track-type tractors will normally provide ample compaction to prevent fires. For low rank coals, such as sub-bituminous and lignite, rubber tired machines, pneumatic compactors or sealing may be required to prevent fires. The following table illustrates the compaction that is possible if the coal is spread in thin lifts and the machine makes a sufficient number of passes over the entire lift surface.

Machine	kg/m ³	lb/ft ³	lb/yd ³
Track-Type Tractors	960-1160	60-72	1620-1950
Wheel Dozers	1040-1200	65-75	1750-2030
Wheel Loaders	1040-1250	65-78	1750-2110
Wheel Tractor-Scrapers	1100-1280	68-80	1840-2160

ESTIMATING HOURLY PRODUCTION

The following graphs may be used for estimating the hourly production of machines handling mixed bituminous coal. The graphs are based on 100% machine efficiency under normal job conditions and average operator; they do not take into account adverse grades, downtime, wait time, poor traction, etc. These production estimates should be evaluated in light of individual job conditions and efficiency. Moreover, a job efficiency correction factor should be applied to the production estimate shown when using these graphs.

To estimate travel times for a specific machine refer to the performance graphs or charts in the appropriate model section of this book.

NOTE: Capacities and production curves on the next pages are based on bituminous coal with a density of 890 kg/m³ or 1500 lb/yd³ or 55 lb/ft³. For sub-bituminous coal with a density of 800 kg/m³ or 1350 lb/yd³ or 50 lb/ft³ multiply tonnage figure by 0.90. For lignite with an average density of 710 kg/m³ or 1200 lb/yd³ or 45 lb/ft³ multiply tonnage figure by 0.80.

Track-Type Tractors Estimated Production with U-Blade (Coal Dozer)

Factors:

- Mixed Bituminous Coal
- Storage and Reclamation
- 0% Grade
- 0.80 Coefficient of Traction

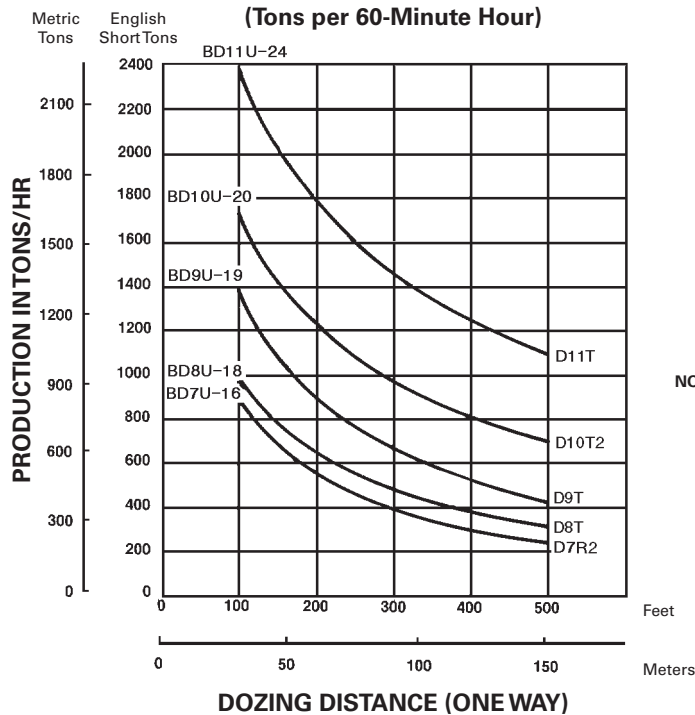

NOTE: This chart is based on numerous field studies made under varying job conditions. Refer to correction factors following these charts.

Tractor	U-Blade			Blade Capacities			
	Model	m	ft	Metric tons	U.S. tons	m ³	yd ³
D11T	BD11U-24	7.32	24'	66.7	73.5	74.9	98.0
D10T2	BD10U-20	6.10	20'	40.85	45.0	45.9	60.0
D9T	BD9U-19	5.79	19'	32.6	35.9	37.0	48.0
D8T	BD8U-18	5.49	18'	19.0	21.0	21.4	28.0
D7R2	BD7U-16	4.88	16'	14.28	15.75	16.05	21.0
D6R	BD6U	4.27	14'	8.84	9.75	9.9	13.0

Refer to Track-Type Tractor/Bulldozer section for additional special attachment specifications.

Wheel Dozers Estimated Production with U-Blade (Coal Dozer)

NOTE: This chart is based on numerous field studies made under varying job conditions. Refer to correction factors following these charts.

Factors:

- Mixed Bituminous Coal
- Storage and Reclamation
- 0% Grade
- 0.80 Coefficient of Traction

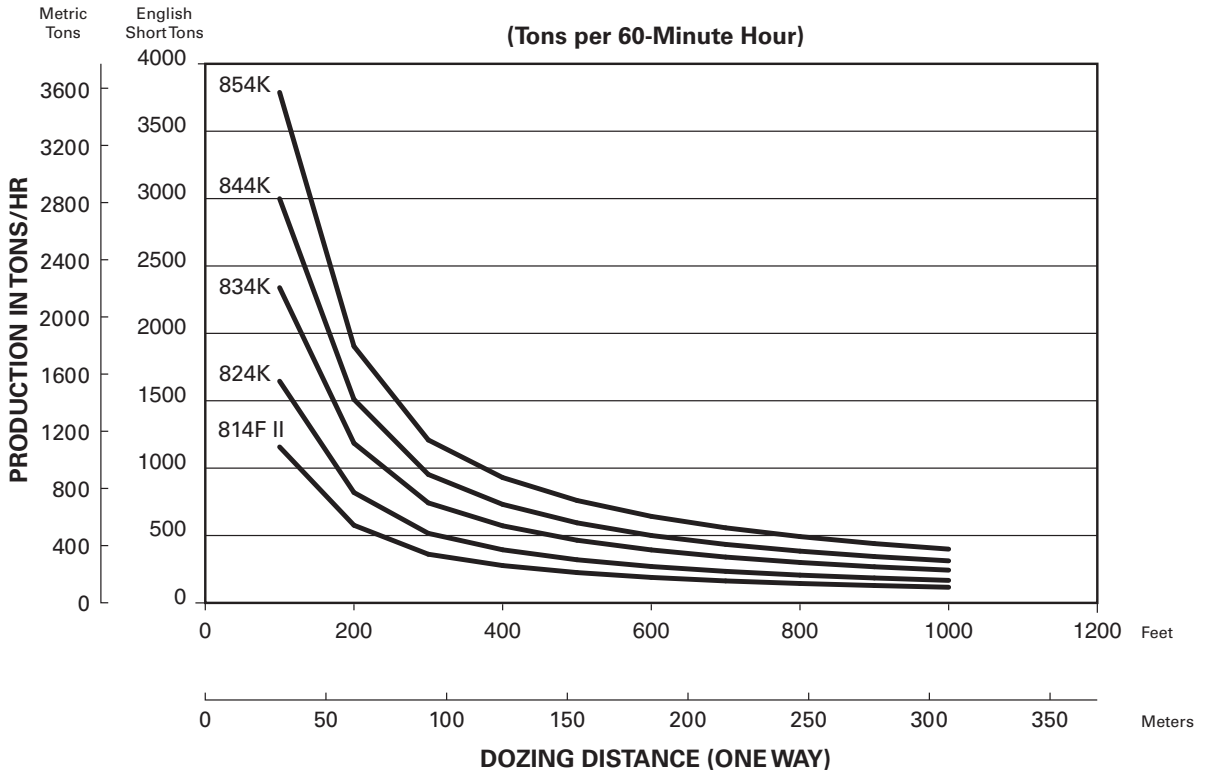

29

Tractor	U-Blade			Blade Capacities			
	Model	m	ft	Metric tons	U.S. tons	m ³	yd ³
854K	153-2113	7.20	23'8"	39.8	43.65	44.7	58.2
844K	153-2111	5.84	19'2"	27.3	30.20	30.7	40.2
834K	376-3845	6.17	20'3"	19.8	21.80	22.2	29.0
824K	BD824U-15	4.79	15'7"	14.2	15.70	16.2	21.1
814F II	BD814U-14	4.32	14'2"	9.4	10.30	11.0	14.0

NOTE: Blade capacities in tons figured using weight of coal at 890 kg/m³ (1500 lb/yd³).

Refer to Track-Type Tractor/Bulldozer section for additional special attachment specifications.

Wheel Dozers Estimated Production with Coal Scoop

Factors:

- **Mixed Bituminous Coal**
- **Storage and Reclamation**
- **0% Grade**
- **0.80 Coefficient of Traction**

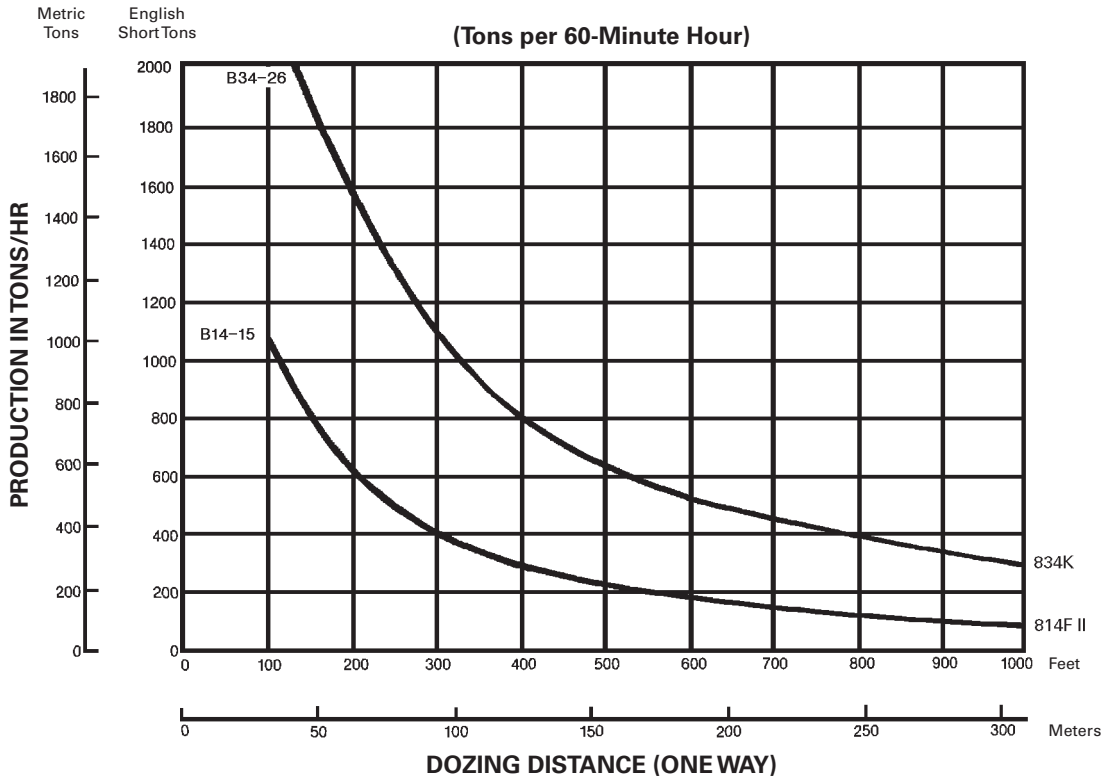

Tractor	Coal Scoop			Scoop Capacities (Lift and Carry)				Doze Capacities			
	Model	m	ft	Metric tons	U.S. tons	m ³	yd ³	Metric tons	U.S. tons	m ³	yd ³
834K	220-3648	4.9	15'11"	19.7	21.8	22.9	30	37.8	41.2	44.2	57.8
814F II	B14-15	3.7	12'3"	8.2	9.0	11.5	15	16.3	18.0	19.1	25

Refer to Track-Type Tractor/Bulldozer section for additional special attachment specifications.

**Wheel Loaders Estimated Production
with Coal Bucket**

Factors:

- Mixed Bituminous Coal
- Storage and Reclamation
- 0% Grade
- 0.80 Coefficient of Traction

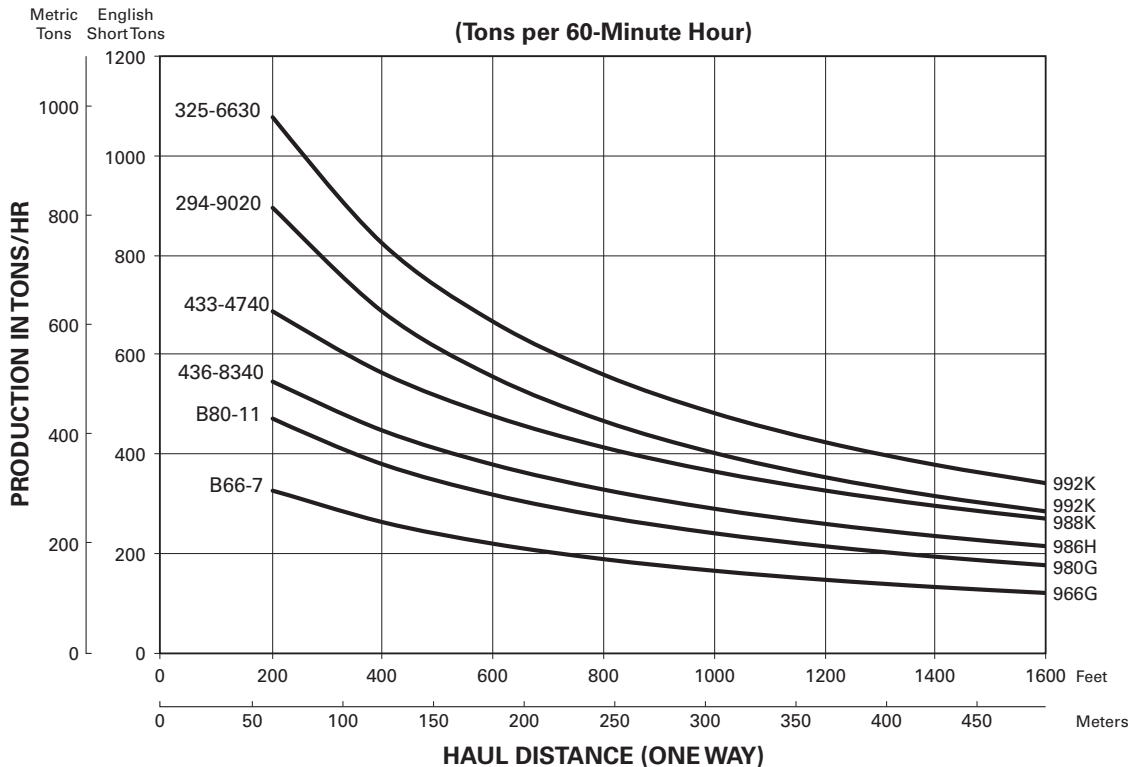

Loader	Coal Bucket	Bucket Capacities			
	Model	Metric tons	U.S. tons	m ³	yd ³
992K	294-9020	17.0	18.8	19.1	25.0
992K	325-6630	20.4	22.5	22.9	30.0
988K	433-4740	11.6	12.8	13.0	17.0
986H	436-8340	9.2	10.1	10.3	13.5
980G	B80-11	7.3	8.1	8.2	10.8
966G	B66-7	4.9	5.4	5.5	7.3

NOTE: Bucket capacities include bottom cutting edge. Figured using weight of coal at 890 kg/m³ (1500 lb/yd³).

Wheel Tractor-Scrapers Estimated Production

Factors:

- Mixed Bituminous Coal
- Storage and Reclamation
- 0% Grade
- 0.50 Coefficient of Traction

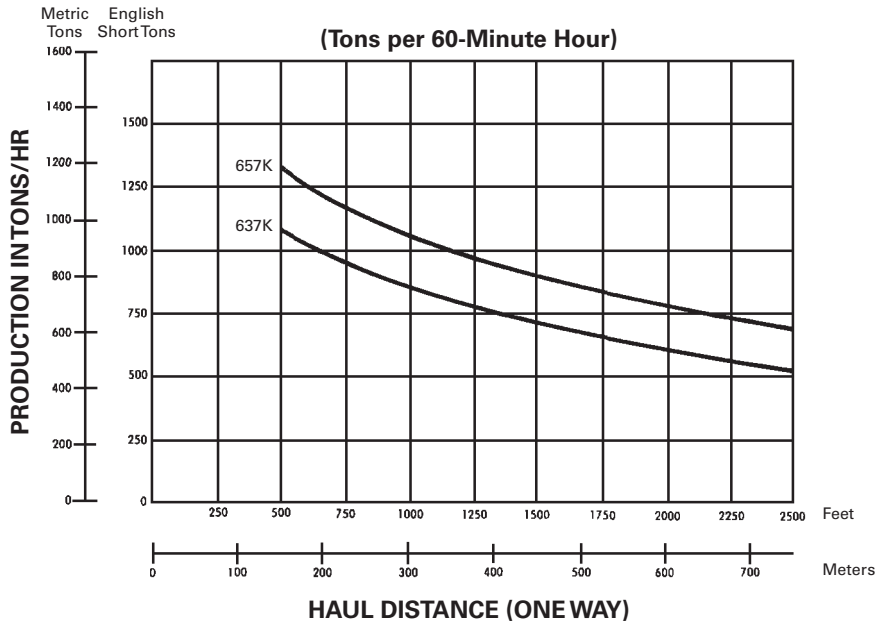

Coal Scraper	Bowl Capacities					
	Metric tons	U.S. tons	Struck		Heaped	
			m ³	yd ³	m ³	yd ³
657K	49.9	55	45	59	56	73
637K	34.5	38	31	41	38	50

Average fixed time to load, maneuver and dump:
 657K – 1.12 min.
 637K – 1.10 min.

NOTE:

- The 657K Coal Scraper is 1072 mm (42.2") longer, the bowl sides are 1010 mm (39.8") taller, the apron is 677 mm (26.7") taller, and the ejector is 944 mm (37.2") taller than its earthmoving counterpart.
- The 637K Coal Scraper is 736 mm (29.0") longer, the bowl sides are 476 mm (18.7") taller, and the apron is 499 mm (19.6") taller than its earthmoving counterpart.
- The rimpull, travel times, and retarder performance for the coal scrapers are the same as for the standard machines. See Wheel Tractor-Scrapers section for charts and graphs.

Example Problem

A coal-fired utility company has a coal requirement of approximately 315 metric tons (350 tons) per hour. Specify the coal handling machine that will satisfy this demand.

Conditions:

- Lignite Coal 710 kg/m³ (1200 lb/yd³)
- 90 m (300 ft) push distance
- 5% adverse grade
- 50 minute hour operation efficiency

Solution:

Calculate the D9T's production equipped with the BD9U-19 Coal U-Blade by using the D9T production curve. Start at 90 m (300 ft) and read up to the D9T production line, then over to the left to determine its maximum hourly production of 612 metric tons (675 tons).

Since the graphs are based on a 890 kg/m³ (1500 lb/yd³) coal density, this production figure has to be adjusted to reflect lignite coal:

Coal density correction factor = $710/890$ (1200/1500) = 0.8.

Obtain the production correction factor for the 5% adverse grade from the chart: 0.9.

The correction factor for the 50 minute hour is $50/60 = 0.83$.

Now calculate the adjusted D9T hourly production using the correction factors:

Metric $612 \times 0.8 \times 0.9 \times 0.83 = 366$ tons/hour

English $675 \times 0.8 \times 0.9 \times 0.83 = 403$ tons/hour

The D9T falls in the required production range. For short periods of peak power capacity, production could be increased by slot dozing.

Production for the D10T2, 824K and 834K can be calculated using the same method.

D10T2

Metric $850 \times 0.8 \times 0.9 \times 0.83 = 508$ tons/hour

English $935 \times 0.8 \times 0.9 \times 0.83 = 559$ tons/hour

824K

Metric $400 \times 0.8 \times 0.9 \times 0.83 = 239$ tons/hour

English $440 \times 0.8 \times 0.9 \times 0.83 = 263$ tons/hour

834K

Metric $689 \times 0.8 \times 0.9 \times 0.83 = 412$ tons/hour

English $760 \times 0.8 \times 0.9 \times 0.83 = 454$ tons/hour

Therefore, the D9T or 834K could most economically satisfy the production requirements.

TABLES

SWELL — VOIDS — LOAD FACTORS

SWELL (%)	VOIDS (%)	LOAD FACTOR
5	4.8	0.952
10	9.1	0.909
15	13.0	0.870
20	16.7	0.833
25	20.0	0.800
30	23.1	0.769
35	25.9	0.741
40	28.6	0.714
45	31.0	0.690
50	33.3	0.667
55	35.5	0.645
60	37.5	0.625
65	39.4	0.606
70	41.2	0.588
75	42.9	0.571
80	44.4	0.556
85	45.9	0.541
90	47.4	0.526
95	48.7	0.513
100	50.0	0.500

BUCKET FILL FACTORS

Loose Material	Fill Factor
Mixed Moist Aggregates	95-100%
Uniform Aggregates up to 3 mm (1/8")	95-100
3 mm-9 mm (1/8"-3/8")	90-95
12 mm-20 mm (1/2"-3/4")	85-90
24 mm (1") and over	85-90
Blasted Rock	
Well Blasted	80-95%
Average Blasted	75-90
Poorly Blasted	60-75
Other	
Rock Dirt Mixtures	100-120%
Moist Loam	100-110
Soil, Boulders, Roots	80-100
Cemented Materials	85-95

NOTE: Loader bucket fill factors are affected by bucket penetration, breakout force, rack back angle, bucket profile and ground engaging tools such as bucket teeth or bolt-on replaceable cutting edges.

NOTE: For bucket fill factors for hydraulic excavators, see bucket payloads in the hydraulic excavator section.

NOTE: Above values are not valid for Hydraulic Mining Shovels.

TYPICAL ROLLING RESISTANCE FACTORS

Various tire sizes and inflation pressures will greatly reduce or increase the rolling resistance. The values in this table are approximate, particularly for the track and track + tire machines. These values can be used for estimating purposes when specific performance information on particular equipment and given soil conditions is not available. See Mining and Earthmoving Section for more detail.

UNDERFOOTING	ROLLING RESISTANCE, PERCENT*			
	Tires		Track	Track +Tires
	Bias	Radial	**	
A very hard, smooth roadway, concrete, cold asphalt or dirt surface, no penetration or flexing . . .	1.5%*	1.2%	0%	1.0%
A hard, smooth, stabilized surfaced roadway without penetration under load, watered, maintained	2.0%	1.7%	0%	1.2%
A firm, smooth, rolling roadway with dirt or light surfacing, flexing slightly under load or undulating, maintained fairly regularly, watered	3.0%	2.5%	0%	1.8%
A dirt roadway, rutted or flexing under load, little maintenance, no water, 25 mm (1") tire penetration or flexing	4.0%	4.0%	0%	2.4%
A dirt roadway, rutted or flexing under load, little maintenance, no water, 50 mm (2") tire penetration or flexing	5.0%	5.0%	0%	3.0%
Rutted dirt roadway, soft under travel, no maintenance, no stabilization, 100 mm (4") tire penetration or flexing	8.0%	8.0%	0%	4.8%
Loose sand or gravel	10.0%	10.0%	2%	7.0%
Rutted dirt roadway, soft under travel, no maintenance, no stabilization, 200 mm (8") tire penetration and flexing	14.0%	14.0%	5%	10.0%
Very soft, muddy, rutted roadway, 300 mm (12") tire penetration, no flexing	20.0%	20.0%	8%	15.0%

*Percent of combined machine weight.

**Assumes drag load has been subtracted to give Drawbar Pull for good to moderate conditions. Some resistance added for very soft conditions.

ANGLE OF REPOSE OF VARIOUS MATERIALS

MATERIAL	ANGLE BETWEEN HORIZONTAL AND SLOPE OF HEAPED PILE	
	Ratio	Degrees
Coal, industrial	1.4:1—1.3:1	35-38
Common earth, Dry	2.8:1—1.0:1	20-45
Moist	2.1:1—1.0:1	25-45
Wet	2.1:1—1.7:1	25-30
Gravel, Round to angular	1.7:1—0.9:1	30-50
Sand & clay	2.8:1—1.4:1	20-35
Sand, Dry	2.8:1—1.7:1	20-30
Moist	1.8:1—1.0:1	30-45
Wet	2.8:1—1.0:1	20-45

Tables

ROUND REINFORCED CONCRETE PIPE APPROXIMATE WEIGHT PER FOOT

INSIDE DIAMETER		WEIGHT PER FT.	
mm	ft/in	kg	lb
305	12"	42	93
380	15"	58	127
460	18"	76	168
530	1'9"	97	214
610	2'0"	120	265
685	2'3"	146	322
760	2'6"	174	384
840	2'9"	205	452
915	3'0"	238	524
1070	3'6"	311	686
1220	4'0"	393	867
1370	4'6"	485	1069
1525	5'0"	588	1295
1675	5'6"	699	1542
1830	6'0"	821	1811
1980	6'6"	952	2100
2135	7'0"	1093	2409
2285	7'6"	1242	2740
2440	8'0"	1402	3090
2590	8'6"	1578	3480
2740	9'0"	1753	3865

NOTE: Table courtesy of American Concrete Pipe Assn.

COEFFICIENT OF TRACTION FACTORS

MATERIAL	TRACTION FACTORS	
	Rubber Tires	Tracks
Concrete	0.90	0.45
Clay loam, dry	0.55	0.90
Clay loam, wet	0.45	0.70
Rutted clay loam	0.40	0.70
Dry sand	0.20	0.30
Wet sand	0.40	0.50
Quarry pit	0.65	0.55
Gravel road (loose not hard)	0.36	0.50
Packed snow	0.20	0.27
Ice	0.12	0.12
Semi-skeleton shoes		
Firm earth	0.55	0.90
Loose earth	0.45	0.60
Coal, stockpiled	0.45	0.60

NOTE: The elevated sprocket design Track-Type Tractors (D11T, D10T2, D9T, D9R, D8T, and D8R), with their suspended undercarriage, provide up to 15% more efficient tractive effort than rigid tracked Track-Type Tractors.

SPEED CONVERSION

km/h Equivalents in m/min				MPH Equivalents in FPM			
km/h	m/min	km/h	m/min	mph	fpm	mph	fpm
1	16.7	21	350.0	1	88	21	1848
2	33.3	22	366.7	2	176	22	1936
3	50.0	23	383.3	3	264	23	2024
4	66.7	24	400.0	4	352	24	2112
5	83.3	25	416.7	5	440	25	2200
6	100.0	26	433.3	6	528	26	2288
7	116.7	27	450.0	7	616	27	2376
8	133.3	28	466.7	8	704	28	2464
9	150.0	29	483.3	9	792	29	2552
10	166.7	30	500.0	10	880	30	2640
11	183.3	31	516.7	11	968	31	2728
12	200.0	32	533.3	12	1056	32	2816
13	216.7	33	550.0	13	1144	33	2904
14	233.3	34	566.7	14	1232	34	2992
15	250.0	35	583.3	15	1320	35	3080
16	266.7	36	600.0	16	1408	36	3168
17	283.3	37	616.7	17	1496	37	3256
18	300.0	38	633.3	18	1584	38	3344
19	316.7	39	650.0	19	1672	39	3432
20	333.3	40	666.7	20	1760	40	3520

NOTE: Since 1 km/h equals 16.7 m/min (1000 ÷ 60), to interpolate add 1.67 m/min for each 0.1 km/h.
NOTE: Since 1 mph equals 88 fpm (5280 ÷ 60), to interpolate add 8.8 fpm for every 0.1 mph.
1 mph = 26.9 m/min.

BEARING POWERS

MATERIAL	BEARING POWER			
	Bar	lb/in ²	Metric t/m ²	U.S. tons/ft ²
Rock (semi-shattered)	4.8	70	50	5
Rock (solid)	24.1	350	240	24
Clay, dry	3.8	55	40	4
medium dry	1.9	27	20	2
soft	1.0	14	10	1
Gravel, cemented	7.6	110	80	8
Sand, compact dry	3.8	55	40	4
clean dry	1.9	27	20	2
Quicksand & alluvial soil	0.5	7	5	0.5

AGRICULTURAL COMMODITIES CONVERSION FACTORS

	lb	kg	Metric Ton
1 Bushel of Corn*	56	25.40	0.02540
1 Bushel of Soybean*	60	27.22	0.02721
1 Bushel of Oats*	32	14.51	0.01451
1 Bushel of Wheat*	60	27.22	0.02721
1 Bale of Cotton	478	216.81	0.21681

1 metric ton of Corn	39.37 Bushels*
1 metric ton of Soybean	36.75 Bushels*
1 metric ton of Oats	68.92 Bushels*
1 metric ton of Wheat	36.75 Bushels*
1 metric ton of Cotton	4.61 Bales

*Bushel is a volume measurement, 1 Bushel = 35.24 liters = 9.31 U.S. Gallons. In the agricultural mercantile exchange, the Bushel is widely used for grains as weight. For the above weights, the market assumes a standard density for each type of grain.

CURVE SUPERELEVATION IN PERCENT GRADE, TO PROVIDE NO LATERAL TIRE FORCE

Negotiating curves can generate high lateral tire forces. These forces contribute to high tire wear and ply separation. Superelevating the curve helps eliminate these forces. The amount of superelevation depends on the curve's radius and the speed at which it is negotiated.

The following table is a guide for providing the superelevation necessary to eliminate lateral forces.

Superelevated turns present a danger when slippery. For this reason, curves superelevated over 10% should be used with caution. Unless the proper speed is maintained, matching the elevation of the curve, a vehicle may slide off of the lower edge of the roadway. Superelevated curves should be maintained in good tractive conditions.

TURN RADIUS		Speed	Speed	Speed	Speed	Speed	Speed	Speed	Speed
m	ft	16 km/h 10 mph	24 km/h 15 mph	32 km/h 20 mph	40 km/h 25 mph	48 km/h 30 mph	56 km/h 35 mph	64 km/h 40 mph	72 km/h 45 mph
15.2	50	13%	30%	—	—	—	—	—	—
30.5	100	7%	15%	27%	—	—	—	—	—
45.7	150	4%	10%	18%	28%	—	—	—	—
61.0	200	3%	8%	13%	21%	30%	—	—	—
91.5	300	2%	5%	9%	14%	20%	27%	—	—
152.4	500	1%	3%	5%	8%	12%	16%	21%	27%
213.4	700	1%	2%	4%	6%	9%	12%	15%	19%
304.9	1000	1%	2%	3%	4%	6%	8%	11%	14%

MAXIMUM SPEED ON CURVES FOR VARIOUS SUPERELEVATION GRADES WITH A 0.20 LATERAL COEFFICIENT OF TRACTION

Another approach to superelevated curves is to determine the safe speed for negotiating a turn at a certain lateral tire force. In general, a 20% lateral coefficient of traction is conservative for all but ice and slippery conditions, making table values safe to use for most applications. The following table shows maximum speed with various superelevations to maintain a 0.20 lateral coefficient of traction.

A transition section may be necessary at higher speeds when entering or departing from a superelevated turn.

TURN RADIUS		Flat Curve		5% Super-elevation		10% Super-elevation	
m	ft	km/h	mph	km/h	mph	km/h	mph
7.6	25	14	9	16	10	17	11
15.2	50	20	12	22	14	24	15
30.5	100	28	17	31	19	34	21
45.7	150	34	21	38	24	42	26
61.0	200	39	24	44	27	48	30
91.5	300	48	30	54	34	59	37
152	500	62	39	70	43	76	47
213	700	74	46	—	—	—	—

Tables

WEIGHT* OF MATERIALS	LOOSE		BANK		LOAD FACTORS
	kg/m ³	lb/yd ³	kg/m ³	lb/yd ³	
Basalt	1960	3300	2970	5000	0.67
Bauxite, Kaolin	1420	2400	1900	3200	0.75
Caliche	1250	2100	2260	3800	0.55
Carnotite, uranium ore	1630	2750	2200	3700	0.74
Cinders	560	950	860	1450	0.66
Clay — Natural bed	1660	2800	2020	3400	0.82
Dry	1480	2500	1840	3100	0.81
Wet	1660	2800	2080	3500	0.80
Clay & gravel — Dry	1420	2400	1660	2800	0.85
Wet	1540	2600	1840	3100	0.85
Coal — Anthracite, Raw	1190	2000	1600	2700	0.74
Washed	1100	1850			0.74
Ash, Bituminous Coal	530-650	900-1100	590-890	1000-1500	0.93
Bituminous, Raw	950	1600	1280	2150	0.74
Washed	830	1400			0.74
Decomposed rock —					
75% Rock, 25% Earth	1960	3300	2790	4700	0.70
50% Rock, 50% Earth	1720	2900	2280	3850	0.75
25% Rock, 75% Earth	1570	2650	1960	3300	0.80
Earth — Dry packed	1510	2550	1900	3200	0.80
Wet excavated	1600	2700	2020	3400	0.79
Loam	1250	2100	1540	2600	0.81
Granite — Broken	1660	2800	2730	4600	0.61
Gravel — Pitrun	1930	3250	2170	3650	0.89
Dry	1510	2550	1690	2850	0.89
Dry 6-50 mm (1/4"-2")	1690	2850	1900	3200	0.89
Wet 6-50 mm (1/4"-2")	2020	3400	2260	3800	0.89
Gypsum — Broken	1810	3050	3170	5350	0.57
Crushed	1600	2700	2790	4700	0.57
Hematite, iron ore, high grade	1810-2450	4000-5400	2130-2900	4700-6400	0.85
Limestone — Broken	1540	2600	2610	4400	0.59
Crushed	1540	2600	—	—	—
Magnetite, iron ore	2790	4700	3260	5500	0.85
Pyrite, iron ore	2580	4350	3030	5100	0.85
Sand — Dry, loose	1420	2400	1600	2700	0.89
Damp	1690	2850	1900	3200	0.89
Wet	1840	3100	2080	3500	0.89
Sand & clay — Loose	1600	2700	2020	3400	0.79
Compacted	2400	4050			
Sand & gravel — Dry	1720	2900	1930	3250	0.89
Wet	2020	3400	2230	3750	0.91
Sandstone	1510	2550	2520	4250	0.60
Shale	1250	2100	1660	2800	0.75
Slag — Broken	1750	2950	2940	4950	0.60
Snow — Dry	130	220			
Wet	520	860			
Stone — Crushed	1600	2700	2670	4500	0.60
Taconite	1630-1900	3600-4200	2360-2700	5200-6100	0.58
Top Soil	950	1600	1370	2300	0.70
Taprock — Broken	1750	2950	2610	4400	0.67
Wood Chips**	—	—	—	—	—

*Varies with moisture content, grain size, degree of compaction, etc. Tests must be made to determine exact material characteristics.

**Weights of commercially important wood species can be found in the last pages of the Logging & Forest Products section. To obtain wood weights use the following equations: lb/yd³ = (lb/ft³) × .4 × 27
kg/m³ = (kg/m³) × .4

ALTITUDE DERATION
PERCENT FLYWHEEL HORSEPOWER
AVAILABLE AT SPECIFIED ALTITUDES

MODEL	0-760 m (0-2500')	760-1500 m (2500-5000')	1500-2300 m (5000-7500')	2300-3000 m (7500-10,000')	3000-3800 m (10,000-12,500')	3800-4600 m (12,500-15,000')
D3K XL	100	100	100	100	88	85
D3K LGP	100	100	100	100	88	85
D4K XL	100	100	100	100	88	85
D4K LGP	100	100	100	100	88	85
D5K XL	100	100	100	100	88	85
D5K LGP	100	100	100	100	88	85
D5R2 XL & LGP	100	100	100	100	N/A	N/A
D5T XL	100	100	100	100	N/A	N/A
D6K2 XL & LGP	100	100	100	100	N/A	N/A
D6N XL & LGP*	100	100	100	100	100	100
D6R Series 3 (All)	100	100	100	100	92	84
D6R2	100	100	100	100	92	84
D6T ¹	100	100	100	100	100	100
D7E	100	100	100	100	99	95
D7R	100	100	100	100	100	96
D8R	100	100	100	93	85	77
D8T	100	100	100	100	100	100
D9R	100	100	100	93	85	77
D9T ¹	100	100	100	100	100	100
D9T ²	100	100	100	99	92	83
D9T ³	100	100	100	100	100	100
D9T ⁴	100	100	100	98	91	80
D9T ⁵	100	100	100	100	99	88
D10T2 ^{5**}	100	100	100	100	100	100
D10T2 ^{6**}	100	100	100	100	100	100
D11T/D11T CD ^{5***}	100	100	100	100	100	86
D11T/D11T CD ^{6***}	100	100	100	100	83	67

*Information not available at time of printing.

**In forward gears.

***D11T — High altitude arrangement available.

¹ Meets U.S. EPA Tier 4 Final/EU Stage IV/Japan 2014 (Tier 4 Final) emission standards.

² Meets Tier 3 equivalent emission standards, North America — Standard Altitude.

³ Meets Tier 3 equivalent emission standards, North America — High Altitude.

⁴ Meets Stage IIIA/Japan 2006 (Tier 3) equivalent emission standards.

⁵ Meets Tier 2/Stage II/Japan 2001 (Tier 2) equivalent emission standards.

⁶ Meets Tier 4 Final.

Tables

ALTITUDE DERATION (Continued)

MODEL	0-760 m (0-2500')	760-1500 m (2500-5000')	1500-2300 m (5000-7500')	2300-3000 m (7500-10,000')	3000-3800 m (10,000-12,500')	3800-4600 m (12,500-15,000')
120K	100	100	100	97	92	85
120K2	100	100	100	97	92	85
120M	100	100	100	100	95	88
120M AWD	100	98	96	94	89	85
120M2	100	100	100	100	94	82
120M2 AWD	100	100	100	100	94	82
12K	100	99	98	94	89	85
12M	100	100	100	100	95	88
12M2	100	100	100	100	100	100
12M2 AWD	100	100	100	100	100	99
12M3	100	100	100	100	100	100
12M3 AWD	100	100	100	100	100	98
140K	100	100	100	100	92	90
140K2	100	100	100	100	92	90
140M	100	100	100	100	92	90
140M AWD	100	100	100	100	92	90
140M2	100	100	100	100	100	99
140M2 AWD	100	100	100	100	97	93
140M3	100	100	100	100	100	98
140M3 AWD	100	100	100	100	100	90
160K	100	100	100	100	92	90
160M	100	100	100	100	92	90
160M AWD	100	100	100	100	92	90
160M2	100	100	100	99	95	91
160M2 AWD	100	100	100	99	94	88
160M3	100	100	100	100	100	90
160M3 AWD	100	100	100	100	98	83
14M	100	100	100	100	100	100
16M3*	100	100	100	100	100	100
16M3**	100	100	100	100	100	95
16M3***	100	100	100	100	100	100
18M3*	100	100	100	100	100	100
18M3**	100	100	100	100	100	95
18M3***	100	100	100	100	100	100
24M B9K**	100	100	95	90	80	70
24M B9K Unregulated	100	100	100	100	90	85
24M B93**	100	100	100	98	89	75
24M B93*	100	100	100	100	91	86

*Meets Tier 2/Stage II/Japan 2001 (Tier 2) equivalent emission standards.

**Meets Tier 3/Stage IIIA/Japan 2006 (Tier 3) equivalent emission standards.

***Meets Tier 4 Final/Stage IV/Japan 2014 (Tier 4 Final) emission standards.

ALTITUDE DERATION (Continued)

MODEL	0-760 m (0-2500')	760-1500 m (2500-5000')	1500-2300 m (5000-7500')	2300-3000 m (7500-10,000')	3000-3800 m (10,000-12,500')	3800-4600 m (12,500-15,000')
216B3	100	89	81	72	61	52
226B3	100	97	95	91	87	83
236D	95	88	81	76	N/A	N/A
242D	95	88	81	76	N/A	N/A
246D	95	88	81	76	N/A	N/A
257D	95	88	81	76	N/A	N/A
259D	95	88	81	76	N/A	N/A
262D	95	88	81	76	N/A	N/A
272D	95	88	81	76	N/A	N/A
272D XHP	95	88	81	76	N/A	N/A
277D	95	88	81	76	N/A	N/A
279D	95	88	81	76	N/A	N/A
287D	95	88	81	76	N/A	N/A
289D	95	88	81	76	N/A	N/A
297D	95	88	81	76	N/A	N/A
297D XHP	95	88	81	76	N/A	N/A
299D	95	88	81	76	N/A	N/A
299D XHP	95	88	81	76	N/A	N/A
300.9D	80	80	80	80	80	80
301.4 C	80	80	80	80	80	80
301.7D	80	80	80	80	80	80
301.7D CR	80	80	80	80	80	80
302.2D	80	80	80	80	80	80
302.4D	80	80	80	80	80	80
302.7D	80	80	80	80	80	80
303E	91	82	73	66	N/A	N/A
303.5E2	91	82	73	66	N/A	N/A
304E2	91	82	73	66	N/A	N/A
305E2	91	82	73	66	N/A	N/A
305.5E2	91	82	73	66	N/A	N/A
308E2	95	88	81	76	N/A	N/A
311D LRR	100	100	100	*	*	*
312D/312D L**	100	100	100	*	*	*
312D/312D L***	97	95	92	*	*	*
313C SR/CR	100	100	100	83	78	73
314D CR/314D LCR	100	100	100	*	*	*
315D L**	100	100	100	*	*	*
315D L***	97	95	92	*	*	*
319D L/319 D LN	97	95	92	*	*	*

*Information not available at time of printing.

**Japan Sourced.

***France Sourced.

Tables

ALTITUDE DERATION (Continued)

MODEL	0-760 m (0-2500')	760-1500 m (2500-5000')	1500-2300 m (5000-7500')	2300-3000 m (7500-10,000')	3000-3800 m (10,000-12,500')	3800-4600 m (12,500-15,000')
M313C	100	97	95	91	N/A	N/A
M315C	100	97	95	91	N/A	N/A
M316C	*	*	*	*	*	*
M318C	100	100	97	95	N/A	N/A
M322C	100	100	97	95	N/A	N/A
M313D	100	100	100	100	*	*
M315D	100	100	100	100	*	*
M316D	100	100	100	100	100	98.9
M318D	100	100	100	100	96.6	91.8
M322D	100	100	100	100	96.1	91.9
M315D2	100	100	100	100	*	*
M317D2	100	100	100	100	*	*
M320D2	100	100	100	100	*	*
M318F	100	100	100	100	*	*
M320F	100	100	100	100	*	*
320E/320E L/320E RR/320E LRR	100	100	100	*	*	*
321D CR/321D LCR	100	100	100	*	*	*
323D2 L	100	100	100	*	*	*
323E L/323E LN/323E SA	100	100	100	*	*	*
323F L	100	100	100	100	*	*
324D/324D L/326D L	100	100	100	100	100-96	96-92
324E/324E L/324E LN	100	100	100	*	*	*
326D2/326D2 L	100	100	100	100	100-96	96-92
326F/326F L/326F LN	100	100	100	100	*	*
328D LCR	100	100	100	100	100-96	96-92
329D/329D L	100	100	100	100	100-96	96-92
329D2/329D2 L	100	100	100	100	100-96	96-92
329E/329E L/329E LN	100	100	100	100	100-96	96-92
329F/329F L/329F LN	100	100	100	100	*	*
335F LCR	100	100	100	100	*	*
336E/336E H	100	100	100	*	*	*
336F/336F XE	100	100	100	*	*	*
336D2 ^{1,2}	100	100	100	100	*	*
336D2 XE ¹	100	100	100	100	*	*
336D2 XE ²	100	100	100	*	*	*
349D2/349D2 L	100	100-96	96	96-89	89-82	82-74
349E/349E L	100	100	100	*	*	*
349F L/352F	100	100	100	*	*	*
349F L XE/352F XE	100	100	100	*	*	*
374F L ²	100	100	100	100	99	94
374F L ¹	100	100	100	100	100	95
374F L ³	100	100	100	100	100	95.5
385C FS ¹	100	100	100	100	100	97
390F L ²	100	100	100	100	100	97
390F L ¹	100	100	100	100	100	99
390F L ³	100	100	100	100	100	95.5

*Information not available at time of printing.

¹ Meets Tier 2/Stage II/Japan 2001 (Tier 2) equivalent emission standards.

² Meets Tier 3/Stage IIIA/Japan 2006 (Tier 3) equivalent emission standards.

³ Meets Tier 4 Final/Stage IV/Japan 2014 (Tier 4 Final) emission standards.

ALTITUDE DERATION (Continued)

MODEL	0-760 m (0-2500')	760-1500 m (2500-5000')	1500-2300 m (5000-7500')	2300-3000 m (7500-10,000')	3000-3800 m (10,000-12,500')	3800-4600 m (12,500-15,000')
422F2 (NA)	95	89	78	72	N/A	N/A
416F2 (Mech Turbo)	99	97	95	92	N/A	N/A
420F2/420F2 IT (Mech Turbo)	99	97	95	92	N/A	N/A
430F2/430F2 IT (Mech Turbo)	99	97	95	92	N/A	N/A
422F2 (Mech Turbo)	99	97	95	92	N/A	N/A
428F2 (Mech Turbo)	99	97	95	92	N/A	N/A
432F2 (Mech Turbo)	99	97	95	92	N/A	N/A
434F2 (Mech Turbo)	99	97	95	92	N/A	N/A
444F2 (Mech Turbo)	99	97	95	92	N/A	N/A
416F2 (Electronic)	100	100	100	100	N/A	N/A
420F2/420F2 IT (Electronic)	100	100	100	100	N/A	N/A
430F2/430F2 IT (Electronic)	100	100	100	100	N/A	N/A
428F2 (Electronic)	100	100	100	100	N/A	N/A
432F2 (Electronic)	100	100	100	100	N/A	N/A
434F2 (Electronic)	100	100	100	100	N/A	N/A
444F2 (Electronic)	100	100	100	100	N/A	N/A
450F (Electronic)	100	100	100	100	N/A	N/A
Forest Products:						
320D FM ¹	100	100	90	87	83	*
324D FM ¹	100	100	100	100	100	100-96
325D FM ¹	100	100	100	100	100-96	96-92
568D FM ²	100	100	100	100-95	97-90	93-85
501HD	100	100	100	100	*	*
517	100	100	100	99	95	87
521B ¹	100	100	100	100	100	100
522B ¹	100	100	100	100	100	100
525D	100	100	100	100	*	*
527	100	100	100	100	99	91
535D	100	100	100	100	*	*
541 Series 2 ¹	100	100	100	100	100	100
545D	100	100	100	100	*	*
555D	100	100	100	100	*	*
552 Series 2 ¹	100	100	100	100	100	100
PL61	100	100	100	100	N/A	N/A
572R2	100*	100*	100*	94	86	80
PL83	100	100	100	100	94	87
PL87	100	100	94	87	80	73
621K	100	100	100	98	80	64
623K	100	100	100	98	80	64
627K Tractor	100	100	100	98	80	64
Scraper	100	100	100	100	98	94
631K	100	100	100	100	97	90
637K Tractor◀	100	100	100	100	97	90
Scraper◀	100	100	100	98	80	64
657K Tractor◀	100	100	100	94	88	81
Scraper◀	100	100	100	95	90	84

*Information not available at time of printing.

◀EUI engine — Automatic altitude deration.

NOTE: Contact factory for deration estimates based upon site specific temperatures and altitudes for altitude range of 3800 to 4600 m (12,500 to 15,000 ft).¹ Meets Tier 3/Stage IIIA/Japan 2006 (Tier 3) equivalent emission standards.² Meets Tier 4 Interim/Stage IIIB/Japan 2011 (Tier 4 Interim) equivalent emission standards.

Tables

ALTITUDE DERATION (Continued)

MODEL	0-760 m (0-2500')	760-1500 m (2500-5000')	1500-2300 m (5000-7500')	2300-3000 m (7500-10,000')	3000-3800 m (10,000-12,500')	3800-4600 m (12,500-15,000')
770G ¹	100	100	100	100-98	98-95	95-83
770G ^{2,3}	100	100	100	100	100-95	95-83
772G ¹	100	100	100	100-98	98-95	95-83
772G ^{2,3}	100	100	100	100	100-98	98-80
773E ³	100	100	100	100	93	85
773G ²	100	100	100	100	100-96	96-94
773G ³	100	100	100	100	100	100
775G ¹	100	100	100	100	100-96	96-94
775G ³	100	100	100	100	100	100-99
777D ⁴ ◀	100	100	100-99.5	99.5-94	94-90	90-85
777G ³	100	100	100	100-95	95-86	86-75
777G ¹	100	100	100	100	100	100
785C 1450 HP ⁴	100	100	100	100	100-92.5	92.5-85
785D 1450 HP ⁵	100	100	100	100	100	100-97
789D 1900 HP ⁴	100	100	100	100-92.5	92.5-85	85-77.5
789D 2100 HP ⁴	100	100	100	100	100-98.5	98.5-91
789D 2100 HP ⁵	100	100	100	100-97	97-89.5	89.5-82
793D 2415 HP ⁴	100	100	100	100-97	97-89.5	89.5-82
793D HAA 2300 HP ⁴	100	100	100	100	100-98.5	98.5-91
793F 2650 HP FO ⁴	100	100	100	100	100-94.5	94.5-87
793F 2650 HP ⁵	100	100	100	100	100-95.5	95.5-88
793F HAA 2650 HP ⁴	100	100	100	100	100	100
795F 3400 HP ⁵	100	100	100-97.5	97.5-85	85-78.5	78.5-76
797F 4000 HP FO ⁴	100	100	100-88	88-80	80-73	70-61
797F 4000 HP ⁵	100	100	100-88	88-80	80-70	70-56
797F HAA 4000 HP ⁵	100	100	100	100	100	100
814F2	*	*	*	*	*	*
824K	*	*	*	*	*	*
834K	100	100	100	100	98	85
844K	100	100	100	98	93	83
854K	100	100	100	98	93	79
815F2	*	*	*	*	*	*
825K	*	*	*	*	*	*
816F2	*	*	*	*	*	*
826H	*	*	*	*	*	*
836H	*	*	*	*	*	*

¹ Meets Tier 4 Final/Stage IV/Japan 2014 (Tier 4 Final) emission standards.

² Meets Tier 3 equivalent emission standards.

³ Meets Tier 2 equivalent emission standards.

⁴ Meets Tier 1 equivalent emission standards.

⁵ Meets Tier 2 equivalent emission standards.

*Information not available at time of printing.

◀Automatic altitude deration.

HAA = High Altitude Engine Arrangement; FO = Fuel Optimized Engine Calibration

NOTE: Contact factory for deration estimates based upon site specific temperatures and altitudes for altitude range of 3800 to 4600 m (12,500 to 15,000 ft).

ALTITUDE DERATION (Continued)

MODEL	0-760 m (0-2500')	760-1500 m (2500-5000')	1500-2300 m (5000-7500')	2300-3000 m (7500-10,000')	3000-3800 m (10,000-12,500')	3800-4600 m (12,500-15,000')
901C (Japan)	91	82	73	66	N/A	N/A
902C (Japan)	91	82	73	66	N/A	N/A
903C	91	82	73	66	N/A	N/A
906K/M	95	88	81	76	N/A	N/A
907K/M	95	88	81	76	N/A	N/A
908K/M	95	88	81	76	N/A	N/A
910K	95	88	81	76	N/A	N/A
914K	95	88	81	76	N/A	N/A
924K ¹	100	100	100	100	100	100
924K	100	100	100	100	98	96
926M ²	100	100	100	100	92	81
930K ¹	100	100	100	100	100	98
930K	100	100	100	100	98	96
930M ²	100	100	100	100	90	77
938K ¹	100	100	100	100	100	91
938K	100	100	100	100	98	96
938M ²	100	100	100	100	82	66
950 GC	100	100	100	98	96	92
950H	100	100	100	100	100	N/A
950K	100	100	100	100	98	95
950M	100	100	100	100	97	91
962H	100	100	100	100	100	N/A
962K	100	100	100	100	98	91
962M	100	100	100	100	95	84
966H	100	100	100	100	100	100
966K	100	100	100	100	94	86
966M	100	100	100	99	91	79
966M XE	100	100	100	98	93	84
972H	100	100	100	100	100	100
972K	100	100	100	100	93	84
972M	100	100	100	99	89	79
972M XE	100	100	100	98	93	84
980H	100	100	100	100	100-93	93-84
980K	100	100	100	100	100	88
980M	100	100	100	100	100	88
982M	100	100	100	98	94	86
986H ⁴	100	100	100	99	98	85
986H ³	100	100	95	94	89	75
988K	100	100	100	100	98	85
990K	100	100	100	98	93	83
992K	100	100	100	98	93	79
993K	100	100	100	99	93	89
994K	100	100	100	100	99	97

¹ Meets Tier 4 Interim/Stage IIIB/Japan 2011 (Tier 4 Interim) equivalent emission standards.

² Meets Tier 4 Final/Stage IV/Japan 2014 (Tier 4 Final) emission standards.

³ Meets Tier 3/Stage IIIA/Japan 2006 (Tier 3) equivalent emission standards.

⁴ Meets Tier 2/Stage II/Japan 2001 (Tier 2) equivalent emission standards.

*Information not available at time of printing.

NOTE: Products are not available in all regions. Contact your local Cat dealer for product availability.

Tables

ALTITUDE DERATION (Continued)

MODEL	0-760 m (0-2500')	760-1500 m (2500-5000')	1500-2300 m (5000-7500')	2300-3000 m (7500-10,000')	3000-3800 m (10,000-12,500')	3800-4600 m (12,500-15,000')
939C	100	100	100	100	*	*
953D	100	100	100	100	N/A	N/A
963D	100	100	100	100	N/A	N/A
973C	100	100	100	100	100	98
TH220B	99	97	95	91	N/A	N/A
TH330B	99	97	95	91	N/A	N/A
TH360B	99	97	95	91	N/A	N/A
TH560B	99	97	95	91	N/A	N/A
TH580B	99	97	95	91	N/A	N/A
PM-565B	100	100	100	*	*	*
RM-250C	100	100	100	100	100	100
RM-350B	100	100	100	*	*	*
AP-800C	99	97	95	91	N/A	N/A
AP-900B	*	*	*	*	*	*
AP-1000B	100	100	100-97	97-93	93-89	89-83
AP-650B	100	100	100	97-93	93-89	89-83
AP-655C	100	100	100	100	*	*
AP-1050B	100	100	100-97	97-93	93-89	89-83
AP-1055B	100	100	100-97	97-93	93-89	89-83
BG-230	99	97	95	91	N/A	N/A
BG-240C	100	100	100-97	97-93	93-89	89-83
BG-260C	100	100	100-97	97-93	93-89	89-83
BG-225C	99	97	95	91	N/A	N/A
BG-245C	100	100	100-97	97-93	93-89	89-83
BG-2455C	100	100	100-97	97-93	93-89	89-83
BG-650	99	97	95	91	N/A	N/A
CS-323C	95	89	81	71	N/A	N/A
CS-423E	100	100-93	93-85	85-77	77-64	64-53
CS-433E	100	100	100	99-96	96-91	91-85
CS-533E	100	100	100-97	97-93	93-89	89-83
CS-563E	100	100	100	100	100	100
CS-573E	100	100	100	100	100	100
CS-583E	100	100	100	100	100	100
CS-663E	100	100	100	100	*	*
CS-683E	100-99	99-97	97-95	95-93	93-89	89-83
CP-323C	100	100-90	90-83	83-73	73-62	62-52
CP-433E	100	100	100-99	99-96	96-91	91-85
CP-533E	100	100	100-97	97-93	93-89	100
CP-563E	100	100	100	100	100	89-83
CP-573E	100	100	100	100	100	100
CP-583E	100	100	100	100	100	100
CP-663E	100	100	100	100	*	*

*Information not available at time of printing.

ALTITUDE DERATION (Continued)

MODEL	0-760 m (0-2500')	760-1500 m (2500-5000')	1500-2300 m (5000-7500')	2300-3000 m (7500-10,000')	3000-3800 m (10,000-12,500')	3800-4600 m (12,500-15,000')
CB-214E	95	90	82	72	62	51
CB-224E/CB-225E	95	90	82	72	62	51
CB-334E	95	90	82	72	62	51
CB-335E	95	90	82	72	62	51
CB-434D	95	89	81	71	N/A	N/A
CB-534D/CB-534D XW	100	100	100	100	100	100
CB-634D	100	100	100-97	97-93	93-89	89-83
PS-150C	95	89	81	71	N/A	N/A
PS-360B	99	97	95	91	N/A	N/A
PF-300B	99	97	95	91	N/A	N/A
PS-300B	99	97	95	91	N/A	N/A
R1300G†	100	100	100	100	100	100
R1600H†	100	100	100	100	100-97	97-94
R1600H (VR)†	100	100	100-99	99-94	94-88	88-81
R1700G†	100	100	100	100	100-95	90
R1700G (VR)†	*	*	*	*	*	*
R2900G†	*	*	*	*	*	*
R2900G (VR)†	100-99	99-98	98-98	98-97	97-90	90-81
R3000H†	*	*	*	*	*	*
R3000H (VR)†	100-99	99-98	98-98	98-97	97-90	90-81
AD30†	100	100	100	100	100-97	90
AD30 (VR)†	100	100	100	100	100-97	90
AD45B†	100	100	100	100-97	97-91	83
AD55†	*	*	*	*	*	*
AD60†	*	*	*	*	*	*
6015/6015 FS◀	100	99-97	97-95	95-91	91-88	88-85
6018/6018 FS◀	100	100	100	100	100-96	96-80
6020B◀	100	100	100	100-98	98-94	94-89
6030/6030 FS◀	100-96	96-89	89-81	81-76	76-71	71-68
6040/6040 FS◀	100	100	100-96	96-91	91-84	84-78
6050/6050 FS ¹	100	100	100	100-90	90-78	78-64
6050/6050 FS ² ◀	100	100	100	100	100	93-83
6060/6060 FS◀	100	100	100	100-99	99-93	93-85
6090 FS ³ ◀	100	100	100	100	100	100

¹ K1500E engines, derating is based on a different rating methodology at lower ambient temperatures.

² QSK38 engines, derating is based on a different rating methodology at lower ambient temperatures.

³ QSK60 engines, derating is based on a different rating methodology at lower ambient temperatures.

⁴ Meets Tier 3/Stage IIIA/Japan 2006 (Tier 3) equivalent emission standards.

*Information not available at time of printing.

◀Automatic altitude deration.

^Ventilation Reduction engine option.

†Assumes ambient air temperature of 25° C (77° F).

NOTE: Derates are reported as a percentage of power and highlights the change from the start to the end elevation in a given column. Contact factory for deration estimates based upon site specific temperatures and altitudes.

Tables

**GRADE COMPARISON CHART
DEGREES – PERCENT – SLOPE**

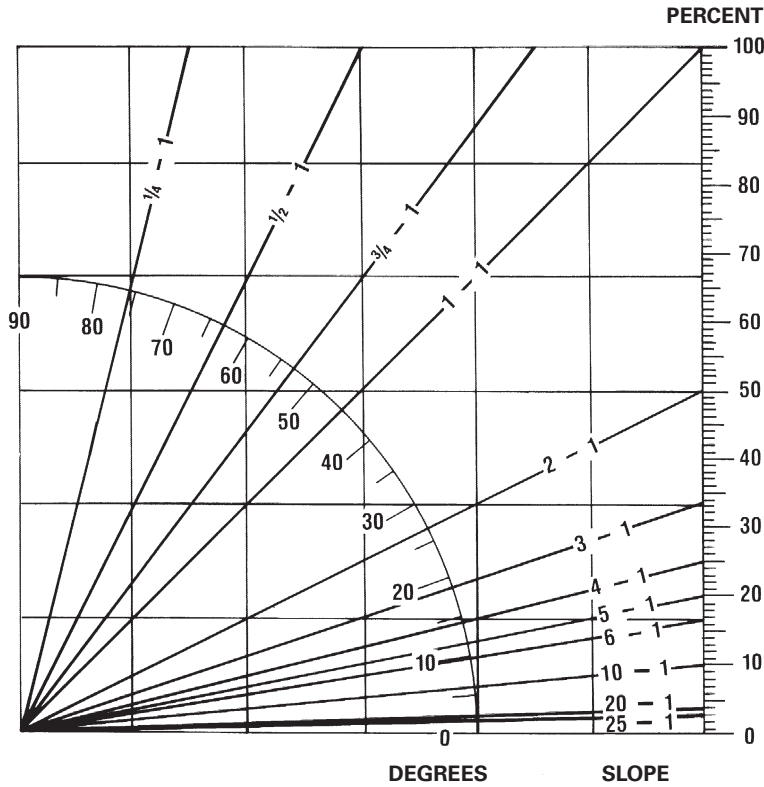

**GRADE IN DEGREES
AND PERCENTS**

DEGREES	PERCENT
1	1.8
2	3.5
3	5.2
4	7.0
5	8.8
6	10.5
7	12.3
8	14.0
9	15.8
10	17.6
11	19.4
12	21.3
13	23.1
14	24.9
15	26.8
16	28.7
17	30.6
18	32.5
19	34.4
20	36.4
21	38.4
22	40.4
23	42.4
24	44.5
25	46.6
26	48.8
27	51.0
28	53.2
29	55.4
30	57.7
31	60.0
32	62.5
33	64.9
34	67.4
35	70.0
36	72.7
37	75.4
38	78.1
39	81.0
40	83.9
41	86.9
42	90.0
43	93.3
44	96.6
45	100.0

CONVERSION FACTORS

Multiply Metric Unit	By	To Obtain English Unit	Multiply English Unit	By	To Obtain Metric Unit
kilometer (km)	0.6214	mile	mile, statute (m)	1.609	kilometer
meter (m)	1.0936	yard	yard (yd)	0.9144	meter
meter (m)	3.28	foot	foot (ft)	0.3048	meter
centimeter (cm)	0.0328	foot	inch (in)	25.4	millimeter
millimeter (mm)	0.03937	inch	sq mile (mile ²)	2.590	sq kilometer
sq kilometer (km ²)	0.3861	square mile	acre	0.4047	hectare
hectare (ha)	2.471	acre	sq foot (ft ²)	0.0929	sq meter
sq meter (m ²)	10.764	square foot	sq inch (in ²)	0.000645	sq meter
sq meter (m ²)	1550	square inch	cu yard (yd ³)	0.7645	cu meter
sq centimeter (cm ²)	0.1550	square inch	cu inch (in ³)	16.387	cu centimeter
cu centimeter (cm ³)	0.061	cubic inch	cu foot (ft ³)	0.0283	cu meter
cu meter (m ³)	1.308	cubic yard	cu inch (in ³)	0.0164	liter
liter (L)	61.02	cubic inch	cubic yard (yd ³)	764.55	liter
liter (L)	0.001308	cubic yard	mph	1.61	km/h
km/h	0.621	mph	Ton — mph	1.459	tkm/h
liter (L)	0.2642	U.S. gallon	U.S. gallon (US Gal)	3.785	liter
liter (L)	0.22	Imperial gallon	U.S. gallon	0.833	Imperial gallon
metric ton (t)	0.984	long ton	long ton (lg ton)	1.016	metric ton
metric ton (t)	1.102	short ton	short ton (sh ton)	0.907	metric ton
kilogram (kg)	2.205	pound, avdp.	pound (lb)	0.4536	kilogram
gram (g or gr)	.0353	ounce, avdp.	ounce (oz)	28.35	gram
kilonewton (kN)	225	pound (force)	pound (lb) (force)	0.00445	kilonewton
newton (N)	0.225	pound (force)	pound (lb) (force)	4.45	newton
cu centimeter (cm ³)	0.0338	fluid ounce	fluid oz (fl oz)	29.57	cu centimeter
kilograms/cu meter	1.686	pounds/cu yd	lb/cu ft (lb/ft ³)	16.018	kg/cu meter
kilograms/cu meter	0.062	pounds/cu ft	lb/cu yd (lb/yd ³)	0.5933	kg/cu meter
kilograms/sq cm (kg/cm ²)	14.225	pounds/sq in	pounds/sq. in.	0.0703	kilogram/sq cm
kilocalorie (kcal)	3.968	Btu	psi	0.0689	bar
kilogram-meter (kg•m)	7.233	foot-pound	psi	6.89	kilopascal
meter-kilogram (m•kg)	7.233	pound-foot	Btu	0.2520	kilogram-calorie
metric horsepower (CV)	0.9863	hp	foot-pound (ft-lb)	0.1383	kilogram-meter
kilowatt (kW)	1.341	hp	horsepower (hp)	1.014	metric horsepower
kilopascal (kPa)	0.145	psi	horsepower (hp)	0.7457	kilowatt
bar	14.5	psi	pounds/cu yd	0.0005928	tons/m ³
tons/m ³	1692	pounds/cu yd	pounds (No. 2 diesel fuel)	0.1413	U.S. gallon
decaliter	0.283	bushel	bushel	3.524	decaliter

NOTE: Some of the above factors have been rounded for convenience. For exact conversion factors please consult International System of Units (SI) table.

Temperature conversion

Degree C

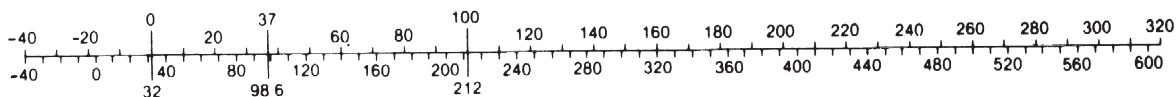

Degree F

$$^{\circ}\text{C} = (^{\circ}\text{F} - 32) \div 1.8$$

$$^{\circ}\text{F} = (\text{C} \times 1.8) + 32$$

Tables

METRIC UNIT EQUIVALENTS

1 km	=	1000 m
1 m	=	100 cm
1 cm	=	10 mm
1 km ²	=	100 ha
1 ha	=	10,000 m ²
1 m ²	=	10,000 cm ²
1 cm ²	=	100 mm ²
1 m ³	=	1000 liters
1 liter	=	1000 cm ³
1 metric ton	=	1000 kg
1 quintal	=	100 kg
1 N	=	0.10197 kg•m/s ²
1 kg	=	1000 g
1 g	=	1000 mg
1 bar	=	14.504 psi
1 cal	=	427 kg•m
	=	0.0016 cv•h
	=	0.00116 kw•h
torque unit		
1 CV	=	75 kg•m/s
1 kg/cm ²	=	0.97 atmosph.

ENGLISH UNIT EQUIVALENTS

1 mile	=	1760 yd
1 yd	=	3 ft
1 ft	=	12 in
1 sq mile	=	640 acres
1 acre	=	43,560 sq ft
1 sq ft	=	144 sq in
1 cu ft	=	7.48 gal liq
1 gal	=	231 cu in
	=	4 quarts liq
1 quart	=	32 fl oz
1 fl oz	=	1.80 cu in
1 sh ton	=	2000 lb
1 lg ton	=	2240 lb
1 lb	=	16 oz, avdp
1 Btu	=	778 ft lb
	=	0.000393 hph
	=	0.000293 kwh
1 mechanical hp	=	550 ft-lb/sec
1 atmosph.	=	14.7 lb/in ²

POWER UNIT EQUIVALENTS

kW	=	Kilowatt
hp	=	Mechanical Horsepower
CV	=	Cheval Vapeur (Steam Horsepower)
		French Designation For
		Metric Horsepower
PS	=	Pferdestärke (Horsepower)
		German Designation For
		Metric Horsepower
1 hp	=	1.014 CV = 1.014 PS
	=	0.7457 kW
1 PS	=	1 CV = 0.986 hp
	=	0.7355 kW
1 kW	=	1.341 hp
	=	1.36 CV
	=	1.36 PS

Machine Model	Engine Model	Machine Model	Engine Model	Machine Model	Engine Model
Track-Type Tractors		Excavators		Front Shovels	
D3K XL/LGP	C4.4 ACERT™	300.9D	Yanmar 3TNV70	385C FS	C18 ACERT
D4K XL/LGP	C4.4 ACERT	301.4C	Yanmar 3TNV76	5130B	3508 (EUI) TA
D5K XL/LGP	C4.4 ACERT	301.7D	Yanmar 3TNV76	5230B	3516B (EUI) TA
D5R	C6.6 ACERT	301.7D CR	Yanmar 3TNV76	Skid Steer/Multi-Terrain/ Compact Track Loaders	
D5R2 XL/LGP	C7.1 ACERT	302.2D	Yanmar 3TNV76	216B3	C2.2
D5T XL	C7.1 ACERT	302.4D	Yanmar 3TNV76	226B3	C2.2T
D6K2 XL/LGP LRC	C7.1 ACERT	302.7D	Yanmar 3TNV76	236D	C3.3B
D6K2 XL/LGP	C6.6 ACERT	303E	C1.3	242D	C3.3B
D6N XL/LGP	C6.6 ACERT	303.5E2 CR	C1.7	246D	C3.3B
D6R2	C9 ACERT	304E2 CR	C2.4	247B3	C2.2T
D6T	C9 ACERT	305E2 CR	C2.4	257D	C3.3B
D6T¹	C9.3 ACERT	305.5E2 CR	C2.6	259D	C3.3B
D7E	C9.3 ACERT	306E	C2.6	262D	C3.3B
D7R	C9 ACERT	307E	C3.3B	272D	C3.8
D8R/D8R LGP	3406C TA	308E	C3.3B	272D XHP	C3.8
D8T/D8T LGP	C15 ACERT	308E2	C3.3B	277D	C3.3B
D9R	3408C TA	311D LRR	C4.2 ACERT	279D	C3.3B
D9T	C18 ACERT	312D/312D L	C4.2 ACERT	287D	C3.3B
D10T2	C27 ACERT	313C SR/CR	3064T	289D	C3.3B
D11T/D11T CD	C32 ACERT	314D CR/LCR	C4.2 ACERT	297D	C3.8
Motor Graders		315D L	C4.2 ACERT	297D XHP	C3.8
120K	C7 ACERT	319D L/319D LN	C4.2 ACERT	299D	C3.8
120K2	C7 ACERT	M313D	C4.4 ACERT	299D XHP	C3.8
120M	C6.6 ACERT	M315D	C4.4 ACERT	Backhoe Loaders	
120M AWD	C6.6 ACERT	M315D2	C4.4 ACERT	416E	3054C
120M2	C7.1 ACERT	M316D	C6.6 ACERT	416F	3054C, C4.4 ACERT
120M2 AWD	C7.1 ACERT	M317D2	C4.4 ACERT	420F	3054C, C4.4 ACERT
12K	C7 ACERT	M318D	C6.6 ACERT	430F	3054C, C4.4 ACERT
12M	C7 ACERT	M318F	C7.1 ACERT	450F	3054C, C4.4 ACERT
12M2	C9.3 ACERT	M320D2	C7.1	422F	3054C
12M2 AWD	C9.3 ACERT	M320F	C7.1 ACERT	428F	3054C, C4.4 ACERT
12M3	C9.3 ACERT	M322D	C6.6 ACERT	432F	3054C, C4.4 ACERT
12M3 AWD	C9.3 ACERT	320D/320D L/320D RR/ 320D LRR	C6.4 ACERT	434F	3054C, C4.4 ACERT
140K	C7 ACERT	321D LCR	C6.4 ACERT	444F	3054C, C4.4 ACERT
140K2	C7 ACERT	323D/323D L	C6.4 ACERT	Pipelayers	
140M	C7 ACERT	324D L	C7 ACERT	PL61	C6.6 ACERT
140M AWD	C9 ACERT	328D LCR	C7 ACERT	572R2	3176CT
140M2	C9.3 ACERT	329D L	C7 ACERT	PL83	C15 ACERT
140M2 AWD	C9.3 ACERT	336E/336E H	C9.3 ACERT	PL87	C15 ACERT
140M3	C9.3 ACERT	336F/336F XE	C9.3 ACERT	Wheel Tractor-Scrapers	
140M3 AWD	C9.3 ACERT	336D2	C9 ACERT	621K, 623K, 627K Tractor	C13 ACERT
160K	C7 ACERT	336D2 XE	C9 ACERT	627K Scraper	C9 ACERT
160M	C9 ACERT	349D2/349D2 L	C13 ACERT	631K	C18 ACERT
160M AWD	C9 ACERT	349E/349E L	C13 ACERT	637K Tractor	C18 ACERT
160M2	C9.3 ACERT	349F L/352F	C13 ACERT	637K Scraper	C9 ACERT
160M2 AWD	C9.3 ACERT	349F L XE/352F XE	C13 ACERT	657G Tractor	C18 ACERT
160M3	C9.3 ACERT	374F L	C15 ACERT	657G Scraper	C15 ACERT
160M3 AWD	C9.3 ACERT	390F L	C18 ACERT		
14M	C11 ACERT	5110B	3412B HEUI™		
16M3	C13 ACERT	5130B	3508B (EUI) TA		
18M3	C13 ACERT	5230B	3516B (EUI) TA		
24M	C18 ACERT				

¹ Meets Tier 4 Interim/Stage IIIB/Japan 2011 (Tier 4 Interim) equivalent emission standards.

Tables

Machine Model	Engine Model	Machine Model	Engine Model	Machine Model	Engine Model
Forest Machines		Wheel Feller Bunchers		Wheel Loaders/Integrated Toolcarriers	
320D ³	6.4 ACERT	553	C6.6 ACERT	901C (Japan)	C1.8
General Forestry (HW)		563	C7 ACERT	902C (Japan)	C2.4
General Forestry (HD/LC)		573	C7 ACERT	903C	C2.4
Log Loader (U/U)				906K/M	C3.3B
324D ³	C7 ACERT	Mining & Off-Highway Trucks		907K/M	C3.3B
General Forestry		770G ¹	C15 ACERT	908K/M	C3.3B
Log Loader (O/U)		770G	C15 ACERT	910K	C3.8
Log Loader (U/U)		772G ¹	C18 ACERT	914K	C3.8
325D ³	C7 ACERT	772G	C18 ACERT	924K ²	C6.6 ACERT
General Forestry		773G ¹	C27 ACERT	924K	C7.1 ACERT
Log Loader (O/U)		773G	C27 ACERT	926M ¹	C7.1 ACERT
Log Loader (U/U)		775G ¹	C27 ACERT	930K ²	C6.6 ACERT
568 FM ²	C9.3 ACERT	775G	C27 ACERT	930K	C7.1 ACERT
General Forestry		777D	3508B (EUI) TA	930M ¹	C7.1 ACERT
Log Loader (O/U)		777G ¹	C32 ACERT	938K ²	C6.6 ACERT
Log Loader (U/U)		777G	C32 ACERT	938K	C7.1 ACERT
		785C	3512B (EUI) TA	938M ¹	C7.1 ACERT
Track Harvesters		785D	3512C HD (EUI) ATAAC	950 GC	C7.1
501HD ³	C6.6 ACERT	789C	3516B (EUI) TA	950H	C7 ACERT
521B ³	C9 ACERT	793D	3516B (EUI) TA	950K	C7.1 ACERT
522B ³	C9 ACERT	793F	C175-16 (EUI) ATAAC	950M	C7.1 ACERT
541 Series 2 ³	C9 ACERT	797F	C175-20 (EUI) ATAAC	962H	C7 ACERT
552 Series 2 ³	C9 ACERT			962K	C7.1 ACERT
				962M	C7.1 ACERT
Wheel Harvester		Articulated Trucks		966H	C11 ACERT
550	C7 ACERT	725	C11 ATAAC	966K	C9.3 ACERT
		730	C11 ATAAC	966M	C9.3 ACERT
		730 Ejector	C11 ATAAC	966M XE	C9.3 ACERT
Wheel Skidders		735	C15 ATAAC	972H	C13 ACERT
525D	C7.1 ACERT	740	C15 ATAAC	972K	C9.3 ACERT
535D	C7.1 ACERT	740 Ejector	C15 ATAAC	972M	C9.3 ACERT
545D	C7.1 ACERT			972M XE	C9.3 ACERT
555D	C7.1 ACERT	Wheel Dozers		980H	C15 ACERT
		814F ⁴	3176C ATAAC	980K	C13 ACERT
Track Skidders		814F II ³	C9 ACERT	980M	C13 ACERT
517	3304 TA	824G Series II ⁴	3406E ATAAC	982M	C13 ACERT
527	3304 TA	824H ³	C15 ACERT	986H	C15 ACERT
		824K ¹	C15 ACERT	988K	C18 ACERT
Forwarders		834K	C18 ACERT	990K	C27 ACERT
564	C6.6 ACERT	844K	C27 ACERT	992K	C32 ACERT
574	C6.6 ACERT	854K	C32 ACERT	993K	C32 ACERT
584	C7 ACERT			994K	3516E HD MUI
584HD	C7 ACERT	Soil Compactors			
		815F ⁴	3176C ATAAC		
Track Feller Bunchers		815F II ³	C9 ACERT	Track Loaders	
521B ³	C9 ACERT	825G Series II ⁴	3406E ATAAC	939C	3046T
522B ³	C9 ACERT	825H ³	C15 ACERT	953D	C6.6 ACERT
541 Series 2 ³	C9 ACERT	825K ¹	C15 ACERT	963D	C6.6 ACERT
552 Series 2 ³	C9 ACERT			973C	C9 ATAAC
		Landfill Compactors			
Knuckleboom Loaders		816F	3176 TA		
519 ³	C6.6	816F II	C9 ACERT		
529 ³	C6.6	826G Series II	3406E TA		
559C	C6.6 ACERT	826H	C15 ACERT		
569 ³	C6.6	836G	3456 TA		
579C	C6.6 ACERT	836H	C18 ACERT		

¹ Meets Tier 4 Final/Stage IV/Japan 2014 (Tier 4 Final) emission standards.

² Meets Tier 4 Interim/Stage IIIB/Japan 2011 (Tier 4 Interim) equivalent emission standards.

³ Meets Tier 3/Stage IIIA/Japan 2006 (Tier 3) equivalent emission standards.

⁴ Meets Tier 2/Stage I/Japan 2001 (Tier 2) equivalent emission standards.

NOTE: All machines are not available in all regions. Contact your local Cat dealer for product availability.

Machine Model	Engine Model	Machine Model	Engine Model	Machine Model	Engine Model
Telehandlers		Wheel Material Handlers		Compactors	
TH255C ²	TD2.9L	M318D MH	C6.6 ACERT	Single Drum, Padded	
TH255C ³	TD2.9L	M322D MH	C6.6 ACERT	CP-323C	3054C
TH336C ² — Standard	C3.4B	M325D MH	C7 ACERT	CP-433E	3054CT
TH336C ² — Optional	C4.4 ACERT	M325D LMH	C7 ACERT	CP54	C4.4 ACERT
TH336C ³ — Standard	C4.4 DITAAC	MH3037 ³	C7.2 ACERT	CP56	C6.6 ACERT
TH337C ² — Standard	C3.4B	MH3037 ¹	C7.1 ACERT	CP64	C6.6 ACERT
TH337C ² — Optional	C4.4 ACERT	MH3049	C9 ACERT	CP74	C6.6 ACERT
TH337C ³ — Standard	C4.4 DITAAC	MH3059	C9 ACERT	CP76	C6.6 ACERT
TH406C ² — Standard	C3.4B	Track Material Handlers		Double Drum and Combi	
TH406C ² — Optional	C4.4 ACERT	385C MH	C18 ACERT	CB14	C1.1
TH406C ³ — Standard	C4.4 DITAAC	Paving Products		CB14 XW	C1.1
TH407C ² — Standard	C3.4B	Cold Planers		CB14 Full Flush	C1.1
TH407C ² — Optional	C4.4 ACERT	PM102	C7 ACERT	CB22	C1.5
TH407C ³ — Standard	C4.4 DITAAC	PM200	C18 ACERT	CB24	C1.5
TH414C ²	C3.4B	PM201	C18 ACERT	CB32	C1.5
TH414C ³	C4.4 DITAAC	Reclaimer/Soil Stabilizers		CC24	C1.5
TH414C GC ²	TDC3.6L4	RM300	C11 ACERT	CB34	C2.2
TH414C GC ³	TDC3.6L4	RM500	C15 ACERT	CB34 XW	C2.2
TH417C ²	C3.4B	Asphalt Pavers		CC34	C2.2
TH417C ³	C4.4 DITAAC	AP600	C6.6 ACERT	CB-434D	3054C
TH417C GC ²	TDC3.6L4	AP600 (EAME)	3056E ATAAC	CB434D XW	3054C
TH417C GC ³	TDC3.6L4	AP800D	3054 DIT	CB-534D/CB-534D XW	3054C
TH514C ²	C3.4B	AP1000D	C7 ACERT	CB564D	3054C
TH514C ³	C4.4 DITAAC	AP655D	C6.6 ACERT	Pneumatic Tire-Asphalt	
TL642C ²	C3.4B	AP655D (EAME)	C6.6 ACERT	PS150C	3054C
TL642C ³	C4.4 DITAAC	AP755 (EAME)	C7 ACERT	PS360C	3054C ATAAC
TL943C ²	C3.4B	AP1055D	C7 ACERT	PF300C	3054C
TL943C ³	C4.4 DITAAC	BG-230D	3054C ATAAC	PS300C	3054C
TL1055C ²	C4.4 ACERT	BG-260D	C7 ACERT	Underground Mining	
TL1055C ³	C4.4 DITAAC	BG-225C	3054C	R1300G	3306B DITA
TL1055D ¹	C4.4	Compactors		R1600H	C11 ACERT ATAAC
TL1055D ³	C4.4	Single Drum, Smooth		R1700G	C11 ACERT ATAAC
TL1255C ²	C4.4 ACERT	CS-323C	3054C	R2900G	C15 ACERT ATAAC
TL1255C ³	C4.4 DITAAC	CS-423E	3054C	R3000H	C15 ACERT ATAAC
TL1255D ¹	C4.4	CS-433E	3054CT	AD30	C15 ACERT ATAAC
TL1255D ³	C4.4	CS54	C4.4 ACERT	AD45B	C18 ACERT ATAAC
		CS56	C6.6 ACERT	AD55	C18 ACERT ATAAC
		CS64	C6.6 ACERT	AD60	C27 ACERT
		CS74	C6.6 ACERT	Hydraulic Mining Shovels	
		CS76	C6.6 ACERT	6015/6015 FS	C18 ACERT
		CS76 XT	C6.6 ACERT	6018/6018 FS	2× C18 ACERT
				6020B	C32 ACERT
				6030/6030 FS	2× C27 ACERT
				6040/6040 FS	2× C32 ACERT
				6050/6050 FS	2× K1500E
				6050/6050 FS ²	2× QSK38
				6060/6060 FS	2× 3512C (EUI) ATAAC
				6090 FS	2× QSK60

¹ Meets Tier 4 Final/Stage IV/Japan 2014 (Tier 4 Final) emission standards.

² Meets Tier 4 Interim/Stage IIIB/Japan 2011 (Tier 4 Interim) equivalent emission standards.

³ Meets Tier 3/Stage IIIA/Japan 2006 (Tier 3) equivalent emission standards.

Tables

Engine Model and (Cylinders)	Machine	Aspiration	Fuel Injection System	Bore × Stroke		Displacement	
				mm	in	L	in ³
3013C (3)	CB-214E, CB-224E, CB-225E	NA	DI	75 × 72	2.95 × 3.54	1.50	91.3
C1.3	303E	NA	DI	78 × 88	3.1 × 3.5	1.3	77
C1.7	303.5E2 CR	NA	DI	87 × 92.4	3.4 × 3.6	1.7	101
C1.8	303.5E, 901C (Japan)	NA	DI	87 × 102.4	3.4 × 4.0	1.8	111.4
C2.2	CB-334E, CB-335E, 216B3	NA	DI	84 × 100	3.31 × 3.94	2.22	135
	226B3, 247B3	T					
C2.4	304E, 305E, 305.5E, 902C (Japan), 903C	NA	DI	87 × 102.4	3.4 × 4.0	2.4	148.5
C2.6	306E (LRC), 307E (LRC)	T	DI	87 × 110	3.4 × 4.3	2.6	159.6
C3.3B	308E (LRC), 308E2 (HRC), 906K/M, 907K/M, 908K/M, 236D, 242D, 246D, 257D, 259D, 262D, 277D, 279D, 287D, 289D	T	DI	94 × 120	3.7 × 4.7	3.3	203.3
C3.8	272D, 272D XHP, 299D, 299D XHP, 910K, 914K	T	DI	100 × 120	3.9 × 4.7	3.8	230
Yanmar 3TNV70	300.9D	NA	IDI	70 × 74	2.8 × 2.9	0.854	52.1
Yanmar 3TNV76	301.4C, 301.7D, 301.7D CR, 302D, 302.4D, 302.7D	NA	IDI	76 × 82	3.0 × 3.2	1.12	68.1
3046 (I-6)	D3G XL, D3G LGP, D4G XL, CS-533E, D4G LGP, D5G XL, D5G LGP, CP-533E, 315C/315C L*, 939C	NA	DI	94 × 120	3.7 × 4.7	5.0	305
		T	DI				
3054C (I-4)	416E, 416F, 420F, 430F, 450F, 422F, 428F, 432F, 434F, 444F	NA/T***	DI	105 × 127	4.13 × 5.0	4.4	268
3054E (I-4)	CB-434D, CS-323C, CS-423E, CP-323C, PS-150C	NA	DI	105 × 127	4.13 × 5.0	4.4	268
	AP-800C, BG-230, BG-650, 908, PS-360B, PF-300B, PS-300B, CS-433E, CP-433E, CB-534C	T (optional)					
	M313C, M315C, AP-650B, 315C L**, BG-225C	TA					
3056 (I-6)	CS-563E, CS-573E, CS-583E, CS-663E, AP-655C, CS-683E, CP-563E, CP-573E, CP-583E, CP-663E, M316C, M318C, M322C	ATAAC	DI	100 × 127	3.94 × 5.0	6.0	365
3064 (I-4)	311C U, 312C, 314C CR/LCR, 313C SR/CR	T	DI	105 × 127	4.1 × 5.0	4.4	268
3066 (I-6)	320C, 320C L, 320C LN, 320C S, 321C LCR	T	DI	102 × 130	4.0 × 5.1	6.4	391

*Japan sourced.

**France sourced.

***Turbo optional on some models.

DI — Direct Injection

T — Turbocharged

TA — Turbocharged and Aftercooled

NA — Naturally Aspirated

ATAAC — Air/Air Aftercooled

NOTE: Materials and specifications subject to change without notice. Component commonality of Cat engines for all applications does not imply complete interchangeability. Contact your Cat dealer for specific information.

TECHNOLOGY PRODUCTS

CONTENTS

Introduction	31-1
Applications	31-3
Construction Technology:	
Cat® Connect.....	31-11
Mining Technology:	
Cat MineStar™.....	31-17

INTRODUCTION

Caterpillar has long been a leader in bringing innovation to Cat products. Today, one of our biggest differentiators isn't just in our equipment — it's in the technologies we are integrating into our products that are improving machine performance and productivity, and transforming the way customers work to manage their operations and business more efficiently and cost effectively.

Caterpillar offers a range of technologies available on Cat equipment that can be customized to meet the needs of work sites in three primary industries:

- Construction
- Energy & Transportation
- Mining

Construction Technology products deliver dramatic improvements on the job site to help customers manage their business more efficiently and cost effectively. Fully integrated into Cat machines and core systems, these technologies use advanced electronics to accurately measure and control productivity, monitor and manage machine health and maintenance, and provide more insight into your equipment fleet and operation.

Energy & Transportation Technology products simplify equipment management to help customers monitor and manage assets, operate at peak performance, and lower operating costs.

Cat Connect combines the latest in technologies and dealer services to help customers improve in four key areas: Equipment Management, Productivity, Safety, and Sustainability to take optimum control of the job site. Whether running one machine, managing a fleet, or overseeing several job sites, Cat dealers can help customers with the right combination of technologies and services to meet the specific needs of their business and realize significant gains in productivity, efficiency and profitability.

- Cat Connect
 - Equipment Management
 - LINK technologies
 - Productivity
 - GRADE technologies
 - COMPACT technologies
 - PAYLOAD technologies
 - Safety
 - DETECT technologies
 - Sustainability

Mining Technology & Autonomy products continue to have a positive impact on mining operations around the world. Caterpillar offers a complete suite of technology products purpose built for the harsh mining environment. Our products combine the latest GNSS positioning technology with sophisticated electronic controls and software to help miners increase productivity, monitor fleet health and lower operating costs.

Cat MineStar provides the most comprehensive suite of mining technology products in the industry. It consists of a number of configurable capability sets that allow you to scale the system to your mine site needs. Cat MineStar helps manage everything from material tracking to sophisticated real-time fleet management, machine health systems, autonomous equipment systems and more. The capability sets — Fleet, Terrain, Detect, Health and Command — can be used in combination or individually to allow your operations the flexibility and scalability it needs to be more productive, efficient and safe.

- Cat MineStar
 - Fleet
 - Terrain
 - Detect
 - Vision
 - Object Detection
 - Proximity Awareness
 - Personnel
 - Health
 - Command
 - Command for dozing
 - Command for underground
 - Command for longwall

PRODUCT	CONSTRUCTION TECHNOLOGY APPLICATIONS	EQUIPMENT
Cat Connect: Equipment Management		
LINK Technologies	LINK technologies enable you to remotely monitor and manage your equipment so you can reduce costs, increase job site efficiency, and effectively manage your business.	Most types of Cat equipment.
Product Link™/ VisionLink®	Product Link wirelessly connects you to your equipment giving you valuable insight into how your machine or fleet is performing. The system tracks location, hours, fuel usage, productivity, idle time, and diagnostic codes through the online VisionLink interface so you can make timely, fact-based decisions to maximize efficiency, improve productivity, and lower the cost of owning and operating your fleet. Available with satellite or cellular connectivity.	Standard on many types of Cat equipment. Retrofits available on Cat or mixed fleet equipment.
VIMS™	Provides operators, maintenance, and fleet managers with vital machine health and production information. VIMS Guardian, a retrofit product, excludes operator display and payload information.	VIMS is available on select Trucks, Track-Type Tractors, Wheel Loaders, Wheel Dozers, Motor Graders, and K Series 4-Drum Soil Compactors.
Cat Connect: Productivity		
GRADE Technologies	GRADE technologies combine digital design data, in-cab guidance, and on some machines — automatic control — to help operators work more productively and accurately with less rework.	Select models of earthmoving, excavation, and paving equipment.
AccuGrade™ Grade Control Systems	<p>Cross Slope systems are used for indicate-only guidance or to control one side of the blade to achieve accurate surface cross slope without any off-board infrastructure. This foundational system for motor graders can be combined with sonic, laser, GNSS or UTS technologies to make fine grading more efficient and productive. Machine mounted sensors are used to calculate necessary blade slope positioning. The system makes automatic adjustments to the left or right lift cylinder. The in-cab display delivers all of the cross slope information the operator needs to quickly and easily spread or cut material at the correct cross slope. The operator can select which side of the blade to control automatically and swap direction on the return pass without readjusting the settings. Elevation is controlled manually by matching grade or automatically by adding an elevation control device (sonic or laser). The cross slope systems are ideal for maintaining accurate cross slope over long distances without the need for infrastructure.</p> <p>Global Navigation Satellite Systems (GNSS) use satellite technology to deliver precise 3D blade elevation and blade tip positioning information to the operator in the cab. Using machine-mounted components, an off-board GNSS base station and accuracy up to Real Time Kinematic (RTK) positioning, GNSS provides the information necessary for the system to accurately determine blade positioning with centimeter level accuracy. GNSS systems compute the positioning information on the machine compared to the position of the implement or machine relative to the design plane and delivers the information to the operator via an in-cab display. GNSS systems put all the information the operator needs to complete a job in the cab, resulting in a greater level of control. Provides precise location and elevation information for complex 3D contour applications, such as golf courses and highway super elevated curves.</p> <p>Laser systems provide precise 2D elevation control for grading with tight tolerances using a laser transmitter and receiver(s). A laser transmitter is set up on the work site to create a constant grade reference over the work area. A digital laser receiver is mounted on the blade of the machine and senses the laser signal as the machine moves across the work site. Laser systems are ideal for the fine grading on job sites with flat, single or dual slope surfaces, such as industrial, commercial or residential building sites.</p>	<p>Motor Graders</p> <p>Asphalt Compactors, Hydraulic Excavators, Motor Graders, Soil Compactors, Track-Type Tractors, Wheel Tractor-Scrapers, Landfill Compactors</p> <p>Compact Track Loaders, Motor Graders, Multi Terrain Loaders, Skid Steer Loaders, Track-Type Tractors</p>

PRODUCT	CONSTRUCTION TECHNOLOGY APPLICATIONS	EQUIPMENT
Cat Connect: Productivity		
<p>AccuGrade Grade Control Systems</p>	<p>Indicate-only grade control systems for excavators provide in-cab guidance to indicate how much to cut or fill to achieve accurate grades and slopes. These systems can be combined with laser, GNSS or UTS technologies to make excavating more efficient and productive. Indicate-only systems provide the operator with precise real-time bucket positioning compared to an elevation reference to indicate how far the cutting edge is above or below desired grade. Using a combination of front linkage (stick, boom and bucket) sensors, the system calculates bucket tip position relative to a grade/survey stake or benchmark. When combined with a laser and receiver, the machine can travel after obtaining a reference benchmark from a laser transmitter to calculate the desired grade for elevation changes over large work sites, significantly increasing productivity. Indicate-only systems combined with laser are ideal for excavations, trenches, and general utility applications.</p>	<p>Hydraulic Excavators</p>
	<p>Sonic systems provide 2D “elevation” control using an ultrasonic sensor to maintain accurate blade height. The system traces a previous pass, string line, or curb and gutter and uses the elevation as a reference. The grade control system calculates blade adjustments based on the reference and desired elevation and automatically moves the blade to achieve grade. The operator simply steers the machine to maintain the sonic tracer over the external reference. Sonic systems are ideal for controlling elevation in fine grading applications where curb and gutter or stringlines are used as references such as road construction and road maintenance.</p>	<p>Motor Graders</p>
	<p>Sonic, Contact and Slope Sensors are combined to provide an elevation control system for paving and milling operations designed to control grade elevation and slope. The goal of grade and slope controls is to remove irregularities from the surface for maximum smoothness and control mat thickness for asphalt pavers and cutting depth for cold planers. The sonic system uses multiple transducers to provide an average of the reference surface while the contact sensor references the actual target to maintain the implement at the same relative vertical distance to an external reference such as a string line or a curb and gutter or even existing pavement. Slope Sensors complement these systems and are designed to control cross slope of the screed or cold planer. These sensors can work individually or together and make automatic elevation adjustments to maintain the appropriate targeted values. The operator simply steers the machine to maintain the sensor over the external reference and monitors the remaining job site variables to ensure a consistent product. Referencing beams are also available both as contact as well as non-contacting styles which help to provide better averaging of the existing surface to help customers achieve their smoothness targets.</p>	<p>Asphalt Pavers, Cold Planers</p>
	<p>Universal Total Station (UTS) systems use high-accuracy, dynamic tracking technology on the job site to track a target mounted on the implement of the machine to determine the most precise 3D positioning. The system uses active target technology to reliably lock onto and track the intended target, eliminating false lock-ons to other active machine targets, survey crews or reflective surfaces. The UTS instrument continuously measures the target’s position and transmits real-time positioning data to the operator via the in-cab display, which shows the exact position of the implement in relation to the design. The system combines the position of the target with the known position of the implement, blade or tips, machine measurements and sensor outputs to calculate precise positioning of the blade tips. The system uses the positioning data to calculate desired elevation and cross slope. Cut and fill values are computed by comparing the positioning of the blade with the design file.</p>	<p>Asphalt Pavers, Hydraulic Excavators, Motor Graders, Track-Type Tractors, Cold Planers</p>

PRODUCT	CONSTRUCTION TECHNOLOGY APPLICATIONS	EQUIPMENT
Cat Connect: Productivity		
Cat Grade Control Cross Slope	<p>Cross Slope systems are used for indicate-only guidance or to control one side of the blade to achieve accurate surface cross slope without any off-board infrastructure. This foundational system for motor graders can be combined with sonic, laser, GNSS or UTS technologies to make fine grading more efficient and productive. Machine mounted sensors are used to calculate necessary blade slope positioning to achieve desired cross slope of the surface. The system makes automatic adjustments to the left or right lift cylinder, typically performed by the operator. Cat Grade Control Cross Slope systems are factory integrated and utilize the existing, standard machine display reducing the need for an additional grade control display for cross slope guidance. The in-cab display delivers all of the cross slope information the operator needs to quickly and easily spread or cut material at the correct cross slope. The operator can select which side of the blade to control automatically and swap direction on the return pass without readjusting the settings. Elevation is controlled manually by matching grade or automatically by adding an elevation control device (sonic or laser). The cross slope systems are ideal for maintaining accurate cross slope over long distances without the need for infrastructure.</p>	M Series, M2 and M3 Series Motor Graders
Cat Grade Control 3D	<p>3D systems use Global Navigation Satellite System (GNSS) satellite technology to deliver precise blade positioning and location information to the operator in the cab. Using machine-mounted components, position sensing hydraulic cylinders, an off-board GNSS base station, and Real Time Kinematic (RTK) positioning accuracy, these systems provide the information necessary to determine precise blade positioning with centimeter level accuracy. The system computes the positioning information on the machine compared to the position of the cutting edge relative to the design plane and delivers the information to the operator via the standard in-cab display. All the information the operator needs to complete a job is delivered to the cab display, resulting in a greater level of control. Cat Grade Control 3D systems also provide overcut protection and linkage to additional Caterpillar exclusive features like AutoCarry™, Automatic Ripper Control and Load Assist. These systems are ideal for high production dozing and cutting complex 3D contours, such as highway projects.</p>	T Series Track-Type Tractors, H and K Series Wheel Tractor-Scrapers
Cat Grade Control Depth and Slope	<p>The 2D indicate-only system for excavators provides the operator with precise real-time bucket positioning relative to the desired grade. Using a combination of position sensing hydraulic cylinders and sensors on the stick and boom pins, the system calculates bucket tip position relative to a grade/survey stake or benchmark. When used with the included laser receiver, the machine can reference a benchmark and travel while maintaining the elevation reference, even on uneven terrain. The laser receiver references the laser from a transmitter on the job site and calculates the desired grade for elevation changes, significantly increasing productivity. The factory-integrated system uses the existing machine display, reducing the need for an additional display. Sensors are deeply integrated and protected from damage in rugged applications. Cat Grade Control Depth and Slope is ideal for maintaining accurate grades and slopes in excavations and trenching applications.</p>	E and F Series Hydraulic Excavators

PRODUCT	CONSTRUCTION TECHNOLOGY APPLICATIONS	EQUIPMENT
Cat Connect: Productivity		
Cat Grade Control Slope Assist	<p>Slope Assist systems provide blade slope/angle control to the cutting edge to achieve accurate slopes with a quality surface finish in less time with less effort — without the need for off-board infrastructure. This integrated machine system uses a blade mounted sensor to calculate necessary blade slope position to achieve desired surface slope and main-fall. The system makes automated adjustments to the lift and tilt cylinders, typically performed by the operator. The in-cab display uses the existing machine display to deliver the information the operator needs to quickly and easily spread or cut material at the correct angle. Two modes are available: basic and advanced. Basic mode maintains the slope of the last given blade command. Advanced mode drives to and maintains a preset target slope. Elevation is controlled manually by matching grade or automatically by adding an elevation control device. This foundational system for dozers can be combined with laser, GNSS or UTS technologies to make grading even more efficient and productive.</p>	Select Track-Type Tractors
Cat Grade and Slope	<p>The Grade and Slope system for asphalt pavers and cold planers utilize a combination of sonic, contact and slope sensors to provide an elevation control system for paving and milling operations designed to control grade elevation and slope. The goal of grade and slope controls is to remove irregularities from the surface for maximum smoothness and control mat thickness for asphalt pavers and cutting depth for cold planers. The sonic system uses multiple transducers to provide an average of the reference surface while the contact sensor references the actual target to maintain the implement at the same relative vertical distance to an external reference such as a string line or a curb and gutter or even existing pavement. Slope Sensors complement these systems and are designed to control cross slope of the screed or cold planer. These sensors can work individually or together and make automatic elevation adjustments to maintain the appropriate targeted values. The operator simply steers the machine to maintain the sensor over the external reference and monitors the remaining job site variables to ensure a consistent product. Referencing beams are also available both as contact as well as non-contacting styles which help to provide better averaging of the existing surface to help customers achieve their smoothness targets. Cat Grade and Slope for asphalt pavers includes vandal protection of the display boxes. Both asphalt pavers and cold planers come factory calibrated, utilize robust harnesses with strain relief components for excellent reliability and durability — a crucial element for paving applications.</p>	Asphalt Paver, Cold Planers
COMPACT Technologies	<p>COMPACT technologies combine advanced compaction measurement, in-cab guidance and reporting capabilities to help consistently meet compaction targets faster, more uniformly, and in fewer passes — reducing rework and material costs in both soil and asphalt applications.</p>	Available on select Cat compactors.

PRODUCT	CONSTRUCTION TECHNOLOGY APPLICATIONS	EQUIPMENT
Cat Connect: Productivity		
Cat Compaction Control	<p>Compaction measurement is the foundation system for vibratory soil compactors. Compaction measurement is a real time indication of soil stiffness, provided by one of two available technologies: accelerometer based Compaction Meter Value (CMV) or Caterpillar exclusive energy based Machine Drive Power (MDP). The compaction measurement system outputs to the standard multipurpose display, providing the operator with real time data that helps them determine the state of compaction.</p> <p>The scalable compaction measurement system can be upgraded to include mapping. Mapping from the factory is an integrated SBAS accuracy GNSS which uses a satellite technology to deliver drum positioning information to the operator in the cab. The factory integrated design protects expensive and fragile components of the system from damage, theft or vandalism in a way that aftermarket systems cannot. The SBAS system from the factory does not require base stations or other off board hardware, but can be easily upgraded in the field with an AccuGrade RTK radio for greater accuracy. Mapping capability allows the operator to record and map compaction measurement values and pass counts, as well as other compaction application data for future analysis.</p> <p>Cat Compaction Control for asphalt compactors and the CW34 pneumatic tire roller provides mat temperature mapping and pass-count information to the operator, ensuring that compaction occurs at the optimum mat temperature and that uniform coverage is completed.</p>	B Series Vibratory Soil Compactors, K Series 4-Drum Soil Compactors, A and B Series Asphalt Compactors, CW34 Pneumatic Tire Roller
PAYLOAD Technologies	PAYLOAD technologies enable accurate weight measurement of material being loaded or hauled. Payload information is shared with loader operators in real-time to improve productivity, reduce overloading and record both weights and number of loads per shift.	Available on select Cat wheel loaders, trucks, excavators and scrapers.
Cat Payload Control	Cat Payload Control System provides on-the-go payload weighing through an in-cab LCD display so operators can deliver exact loads with confidence and work more efficiently. Operators can fill trucks to capacity without overloading, increasing productivity and eliminating costly fines. The system records detailed data to track productivity, including time/date, weights, cycles, and more. An optional in-cab printer enables operators to print individual load tickets as well as truck and material summary reports. Daily summary reports in the <i>VisionLink</i> web portal and detailed payload reports in <i>VIMSpC</i> software are available for productivity reporting and analysis.	H and K Series Wheel Loaders
Cat Production Measurement	Cat Production Measurement brings on-the-go payload weighing to cab to help operators deliver exact loads with confidence and work more productively and accurately; without rework. The system is integrated at the factory into the standard cab display. Operators can track load weights in real time and know precisely how much material is in the bucket or truck. Instant payload feedback gives operators the confidence to know when loads are filled to target capacity, which reduces under and overloading, and maximizes the potential of the entire fleet. Payload information is stored in the display, enabling operators to track productivity such as weights, and totals per shift while in the cab. Productivity data can be accessed wirelessly through the <i>VisionLink</i> web portal giving the site supervisor a daily view of production totals and efficiency metrics.	M and K Series Wheel Loaders, C Series Articulated Trucks, F Series Excavators

PRODUCT	CONSTRUCTION TECHNOLOGY APPLICATIONS	EQUIPMENT
Cat Connect: Productivity		
Payload Estimator	Payload Estimator uses bowl lift cylinder pressure on the loaded haul segment to calculate payload. This integrated system provides on-the-go payload weighing through the standard machine display so operators can deliver exact loads with confidence and work more efficiently. Deep integration ensures reliable operation and accurate data (within $\pm 5\%$). It is optimized to work with Sequence Assist or can be used in manual mode. Productivity data can be accessed wirelessly through VisionLink, giving the site supervisor a daily view of production totals.	H and K Series Wheel-Tractor Scrapers
Truck Production Management System (TPMS)	Truck Production Management System (TPMS) enhances truck and loader effectiveness for improved fleet productivity and reduced operating cost. TPMS offers external lights or an optional digital display to signal the loading tool operator when the proper load is reached. The on-board system provides a payload accuracy of $\pm 5\%$ and stores payload weight, cycle segment times, cycle segment distance and fuel, operator ID and actual clock time and date of each cycle.	Off-Highway Trucks
Cat Connect: Safety		
DETECT Technologies	DETECT technologies combine safety and monitoring systems to enhance operator awareness. By expanding your view of the working environment around your equipment, you can improve the safety and productivity of your entire operation and keep your people and assets safe.	Available on many models of Cat equipment.
Rear Vision Cameras	Rear vision cameras greatly enhance visibility behind the machine to help the operator work more productively. On many machines, the camera view is displayed through the standard display.	Standard on many types of Cat equipment. Retrofits available on most models.
WAVS (Work Area Vision System)	Work Area Vision System (WAVS) is used on larger equipment in applications where there are multiple machines, such as in a quarry. WAVS uses up to three cameras to provide full coverage in areas of limited visibility. Views can be set up by camera location (front, rear, side) or programmed to switch automatically based on direction of travel.	Optional on larger trucks and wheel loaders.
Cat Tire Monitoring	Cat Tire Monitoring uses sensors located on the rims to display tire pressures and temperatures on the in-cab monitor to help keep fleets running safely and productively. Operators can view real-time information via the Messenger display and work with confidence. Alerts enable operators to take immediate action before a tire failure occurs to reduce downtime. The system optimizes fuel consumption by operating at optimum tire pressures and reduces tire damage and frequent replacements due to high tire temperatures and under-inflation. Caterpillar designed and tested aftermarket kits work with multiple machine models and mixed fleets. Remote monitoring via VisionLink helps equipment managers schedule maintenance and make informed decisions.	All Cat and mixed fleet machines with tubeless tire rim sizes R29.5 and smaller.
MSS (Cat Machine Security System)	Cat Machine Security System (MSS) prevents unauthorized personnel from starting the machine by using a uniquely coded key that is programmed to a computer chip in the MSS module on-board the machine. The system can be set to prevent unauthorized use outside of normal working hours, and protect from vandalism or theft.	Standard on many types of Cat equipment.

PRODUCT	ENERGY & TRANSPORTATION TECHNOLOGY APPLICATIONS	EQUIPMENT
Energy & Transportation		
Product Link Web	Product Link Web provides features optimized for power systems equipment, including detailed engine parameters. An innovative tool for equipment management, the Product Link Web user-friendly interface enables communication between the customer and their equipment assets, and provides comprehensive information about the performance and condition of the equipment. It also enables the user to customize alerts so that critical operations can be prevented and or receive immediate attention.	Oil and Gas, Marine, Electric Power Generation, and Industrial installations
Asset IQ Kits	AssetIQ Kits are field-installed solutions for collecting engine data and information on Cat or other manufacturers' mechanical or basic electronic equipment. Kits are available for Fuel Flow Monitoring Systems and Sensor Kits for basic engines and genset applications.	Oil and Gas, Marine, Electric Power Generation, and Industrial installations

PRODUCT	MINING TECHNOLOGY & AUTONOMY APPLICATIONS	EQUIPMENT
Cat MineStar		
Fleet	Fleet is a comprehensive mine management system featuring an advanced truck assignment engine, health and operational event alarming, "what-if" analysis, productivity tracking, machine tracking, material management and a comprehensive reporting package. Integrating with other Cat MineStar capability sets, Fleet improves productivity by 10-15%, eliminates misdirected loads, improves information availability and provides greater flexibility to adjust for changing mine and market conditions.	Entire mining fleet
Terrain	Terrain for drilling increases hole placement and depth accuracy while removing the cost of drill pattern survey and staking. Position and status information of other drills working on the same pattern is provided to operators in real time on the in-cab display. Terrain for draglines enables production monitoring of all dragline activities, right down to individual bucket loads and dump locations. Machine performance, productivity and payload are monitored and organized in reports to optimize dragline output and minimize operating costs. Terrain for grading ensures accurate execution of the design plan and enables safe operating practices. It can be used on a variety of machines in numerous applications from production dozing to reclamation, all helping you mine more safely and productively. Terrain for loading provides accurate information on each pass helping operators to move the right amount of material with every bucket load. Safety, productivity and efficiency are positively impacted and the mine design plan accurately executed.	Blasthole Drills, Articulated Drills, Draglines, Scrapers, Loaders, Dozers, Shovels, Motor Graders, Hydraulic Excavators, Track-Type Tractors, Surface Miners, Terrain Levelers

PRODUCT	MINING TECHNOLOGY & AUTONOMY APPLICATIONS	EQUIPMENT
Cat MineStar		
Detect	<p>Vision is a camera system available on mobile surface equipment and underground longwall systems. It provides multiple camera views that improve the operator’s awareness of the vicinity around working equipment.</p>	<p>Surface: Select models of Electric Rope Shovels, Hydraulic Shovels, Off-Highway Trucks, Medium Wheel Loaders, Large Wheel Loaders, Large Motor Graders, Medium Wheel Dozers, Large Wheel Dozers Underground: Longwall Systems</p>
	<p>Object Detection uses cameras and radars to improve the operator’s view of key areas around the machine, allowing operators to make informed decisions. The system works with several machine types increasing machine perimeter awareness during critical periods including startup, initial movement and reverse travel. The system consists of an interactive touch screen display, radars and cameras on the front, rear and sides of the machine. Radar and camera configuration will vary by machine type.</p>	<p>Select models of Off-Highway Trucks, Medium Wheel Loaders, Large Wheel Loaders, Large Motor Graders, Medium Wheel Dozers, Large Wheel Dozers</p>
	<p>Proximity Awareness is a GNSS based system which tracks machines and light vehicles, allowing operators to view other machine locations and provide proximity based alarming. The system alerts operators based on speeding violations, hazards and avoidance zone entry. Office software allows mine managers to capture incidents for playback and reconstruction. Proximity Awareness is active whenever the machine is in operation providing complete coverage.</p>	<p>Entire mining fleet</p>
	<p>Personnel uses locator tags that indicate each person’s location and proximity to moving equipment. When a roof support is given a command to advance on a longwall face and a tag is detected as being in “harms way,” the roof support won’t advance until that person has moved a safe distance away.</p>	<p>Longwall Systems</p>
	<p>A Fatigue Risk Management System helps manage unseen risk factors that impact customer operations daily. On-machine technology gives the power to visualize and quantify the prevalence of fatigue and distraction events in conjunction with Caterpillar experts that help mines make immediate improvements and create a long-term plan for performance excellence.</p>	<p>Site level solution</p>
Health	<p>Health delivers critical event-based equipment condition and operating data for your entire fleet. It includes comprehensive, proactive health and asset monitoring capabilities, with a wide range of diagnostic, reporting tools, analytics and recommendations.</p>	<p>Cat mining equipment and select models of other brands of mining machines</p>
Command	<p>Command for underground is designed to enhance safety and boost operator efficiency and effectiveness. The system allows the operator to work from a safe and ergonomic work station far from the Load Haul Dump (LHD) machine — either on the surface or underground without sacrificing machine productivity. The system can also have a significant impact through increased machine availability, decreased operating costs and extended machine life.</p>	<p>Available as an attachment for select models of Hard Rock Underground Mining Loaders</p>
	<p>Command for longwall offers semi-autonomous control for Cat plows. Automation of steering and shield movement, along with plow automation no longer require operators to be at the working face, enhancing safety.</p>	<p>Cat Plows</p>
	<p>Command for dozing enables remote operation from a safe location away from the machine. Removing operators from the cab of a machine working in hazardous conditions promotes safety and reduces operator exposure to dust, noise and vibration. Command for dozing can utilize either an over the shoulder operator console or a seated operator station for longer term operations. Either system utilizes line of sight communications for distances up to 400 m (1312 ft) depending on conditions. Terrain’s avoidance zone functionality (optional) can be utilized to further enhance safety.</p>	<p>D10T, D11T, D11T CD Track-Type Tractors</p>

CAT CONNECT

Cat Connect combines the latest in construction technologies and dealer services to help customers improve in four key areas: Equipment Management, Productivity, Safety, and Sustainability. Because every job site has its own unique challenges — whether running one machine, managing a fleet, or overseeing several job sites — Cat Connect enables customers to combine technologies and services in ways that make the most sense for their business and realize significant gains in productivity, efficiency and profitability.

Cat Connect offers the following technologies:

- LINK
- GRADE
- COMPACT
- PAYLOAD
- DETECT

EQUIPMENT MANAGEMENT SOLUTIONS

LINK Technologies

LINK technologies wirelessly connect you to your equipment giving you access to essential information you need to know to run your business. Link data can give you valuable insight into how your machine or fleet is performing so you can make timely, fact-based decisions that can boost job site efficiency and productivity.

Product Link

Product Link is deeply integrated into the equipment, interacting with engine, transmission and implement control systems to help you take the guesswork out of equipment management. Easy access to timely information can help you effectively manage your fleet and lower operating costs.

Features for asset management, fleet monitoring, maintenance, health, utilization, and productivity are available. Product Link is designed for Cat equipment and provided factory standard on many Cat models delivered to customers in over 50 countries around the world.

The Product Link platform provides support for the specific needs of the construction and power systems industries by offering an intuitive web based user interface specialized for each market. The VisionLink application for construction and the Product Link Web application for the Energy and Transportation Systems industries, offers powerful tools and features to process and convey information to users and dealers. They also include essential tools to manage your entire fleet of equipment incorporating mapping, utilization and more.

Hardware options provide the ability to transmit information from (and to) your equipment via cellular network or Low-Earth-Orbit satellites. The family of enabling hardware provides you the ability to select the right fit option for the location for which your fleet operates.

Consult with your dealer's Product Link specialist for additional details.

VIMS

VIMS is a fully integrated technology solution that uses sensors located throughout the machine to monitor crucial machine health, performance and productivity information. VIMS captures detailed, up-to-the minute data and displays it for the operator in real-time. The system alerts operators of abnormal machine conditions and provides instructions if action is needed. Data, such as historical trends, histograms, events and more can be transferred wirelessly or manually to the office for off-board analysis. VIMS PC software and the Health module within the Cat MineStar are predictive analysis tools used to analyze and interpret the data and provide reports that provide actionable information for informed decision making on machine performance, productivity issues, operations improvements, and fleet management. (Available data varies by machine model and type.)

Value of VIMS

- For the machine operator VIMS establishes two-way communication between the operator and the machine. Real-time machine information allows the operator to make informed decisions that directly affect safety, machine availability, and maximize productivity.
- For maintenance VIMS provides an in-depth view of operator and machine performance. This allows maintenance managers and technicians to maximize component life, reduce catastrophic failures, minimize unscheduled downtime and improve asset management.
- For production VIMS collects the information needed to monitor equipment usage, personnel performance, and productivity levels. Payload information can be used as an accounting tool, an indicator of cycle time efficiency and truck overloading or under loading.

GRADE Technologies

Grade technologies combine digital design data, in-cab guidance, and automatic controls to enhance grading accuracy, reduce rework, and lower costs related to paving and earthmoving in rough, fine and finish grade applications.

GRADE CONTROL SYSTEMS

Grade control systems increase productivity by moving material right the first time and achieving accurate grades without rework. These systems compute and track the location of the bucket or blade and compare this information with design parameters to guide to the operator to grade. In-cab displays with easy-to-use operator interface provide grade information in real time. Basic systems provide indicate-only information, while more enhanced systems can signal the machine hydraulics to move the blade to the desired design automatically. Grade control systems increase productivity, improve performance for less experienced operators, reduce operator fatigue, and enhance overall job site safety.

Grade control systems offer customers these advantages and cost-savings:

- Increase productivity
- Reduce fuel savings
- Reduce guesswork and costly rework
- Reduce survey costs
- Reduce staking, string lines and grade-checkers
- Increase material utilization
- Reduce owning and operating costs
- Reduce labor requirements and costs
- Finish jobs faster
- Work more confidently
- Extend the work day

Cat Grade Control

Many aftermarket systems exist in the market today, but no system designed by someone other than the OEM can bring the advantages that integration makes possible.

Depending on the machine family and the specific application, many of the components necessary for automation are already present on a Cat machine. Cat Grade Control leverages these components and optimizes the design as only Caterpillar can. Whether it is a sensor, cylinder, display or software, Cat Grade Control integration is designed to reduce redundant components, protect sensors and allow productivity features to work together.

Cat Grade Control integrates traditional grade control with machine hardware and software in the factory to improve productivity, usability, reliability, job site safety and machine value. It is another example of Caterpillar innovation and technology leading the way for our customers to be more successful.

Cat Grade Control is comprised of the following technologies:

- Cross Slope
- 3D
- Depth and Slope
- Slope Assist
- Grade and Slope

COMPACT Technologies

COMPACT technologies combine advanced compaction measurement, in-cab guidance and reporting capabilities to help you consistently meet compaction targets faster, more uniformly, and in fewer passes — reducing rework and material costs in both soil and asphalt applications.

COMPACTION CONTROL SYSTEMS

Compaction is one of the most critical steps in the construction and road building process. Successful projects rely on achieving target compaction to stringent design specifications to ensure structural stability of the finished product.

Asphalt compaction technologies display mat temperature in the cab, indicating when and where operators need to work to quickly achieve consistent quality results. The system measures mat temperatures in real time, indicating the approach of tender zones and where the operator can work productively.

Soil compaction technologies give operators the information and instant feedback they need to achieve uniform results with maximum efficiency. Plus, it helps to identify hidden soil problems that can affect compaction quality.

Compaction control systems offer customers these advantages and cost-savings:

- Increase productivity
- Reduce fuel savings
- Reduce guesswork and costly rework
- Increase material utilization
- Reduce owning and operating costs
- Reduce labor requirements and costs
- Provide Quality Control/Quality Assurance Documentation
- Finish jobs faster
- Work more confidently
- Extend the work day

Cat Compaction Control

Cat Compaction Control provides information about the state of compaction to operators. The optional system comes with a choice of two different measurement technologies, Compaction Meter Value (CMV) and Machine Drive Power (MDP). CMV is an accelerometer-based system that displays a compaction value that indicates compaction quality. CMV is for smooth drum machines only and works well in granular applications and thick lifts. It is a Caterpillar exclusive technology that measures rolling resistance — with the vibratory system on or off — and correlates it with soil stiffness. MDP is for smooth and padfoot drums and works well in both cohesive or granular soils.

Optional 3D Mapping enables temperature or compaction measurements to be mapped to the precise location the operator is working, providing a real time view of progress. Mapping data is recorded to document compaction uniformity and job completion.

Cat Compaction Control uses the following technologies:

- Compaction Meter Value (CMV)
- Machine Drive Power (MDP)
- GNSS (SBAS)

AccuGrade Grade Control System

AccuGrade systems are dealer installed technologies that can be used to guide an operator to grade, manually using in-cab guidance, or automatically by controlling the blade movements to help operators get to grade faster, and more accurately. The systems use machine mounted sensors to calculate precise blade/tool location, slope and/or elevation information. The integrated electrohydraulic valve control module uses the information received from the sensors to control the machine's hydraulic system and automatically adjust the blade's cutting edge to maintain grade on select machines. Depending on the configuration, the operator can select which side of the blade/tool to control — right, left, or both sides. AccuGrade brings to the customer an increase in productivity by up to 40% while reducing their site costs dramatically.

AccuGrade technologies include:

- Cross slope
- Sonic
- Site Reference
- Laser
- GNSS
- UTS

PAYLOAD Technologies

Payload technologies enable accurate weight measurement of material being loaded or hauled. Payload information is shared with loader operators in real-time to improve productivity, reduce overloading and record both weights and number of loads per shift.

Payload Control

Cat Production Measurement for Wheel Loaders, Excavators, and Articulated trucks is integrated from the factory and brings payload weighing to the cab to help operators work more productively and accurately; without rework. Operators can track load weights in real time on the in-cab monitor and know precisely how much material is in the bucket or truck. The system uses data from a series of onboard sensors that is processed by the onboard computer to calculate payload weight. Instant payload feedback through the display gives operators the confidence to work more efficiently and know when loads are filled to target capacity. Truck system also features external payload lights to indicate when the load is full.

Payload Estimator

Payload Estimator for Scrapers uses bowl lift cylinder pressure during the loaded haul segment to calculate payload. When working in manual operation, the system is optimized to work with Sequence Assist for increased productivity with less effort. Deep integration ensures reliable operation and accurate data (within $\pm 5\%$).

Payload technologies maximize the potential of the entire fleet:

- Enables operators to consistently fill to target payload
- Reduces under loading that reduces productivity, increases haul cycles, fuel usage, and operating costs
- Allows operators to track productivity such as weights and totals per shift
- Reduces overloading that can cause excessive wear on equipment and haul roads and lead to safety concerns

Truck Production Management System

Truck Production Management System (TPMS) enhances truck and loader effectiveness to improve fleet productivity and reduce operating costs. TPMS offers external lights or an optional digital display to signal the loading tool operator when the proper load is reached. The on-board system provides a payload accuracy of $\pm 5\%$ and stores payload weight, cycle segment times, cycle segment distance and fuel, operator ID and actual clock time and date of each cycle.

DETECT Technologies

DETECT technologies combine safety and monitoring systems to enhance operator awareness. By expanding your view of the working environment around your equipment, you can improve the safety and productivity of your entire operation and keep your people and assets safe.

Rear vision cameras greatly enhance visibility behind the machine to help the operator work more productively. On many machines, the camera view is displayed through the standard display.

Work Area Vision System (WAVS) is used on larger equipment in applications where there are multiple machines, such as in a quarry. WAVS uses up to three cameras to provide full coverage in areas of limited visibility. Views can be set up by camera location (front, rear, side) or programmed to switch automatically based on direction of travel.

Cat Tire Monitoring enables operators to monitor tire pressures and temperatures on the in-cab monitor. Alerts enable operators to take immediate action before a tire failure occurs and avoid unsafe operation.

Cat Machine Security System (MSS) prevents unauthorized personnel from starting the machine by using a uniquely coded key that is programmed to a computer chip in the MSS module on-board the machine. The system can be set to prevent unauthorized use outside of normal working hours, and protect from vandalism or theft.

CAT MINESTAR

Cat MineStar is a comprehensive suite of technologies that allows you to see your entire operation at a glance, then drill down to the individual asset level as required. Its capability sets — Fleet, Terrain, Detect, Health and Command — enable you to define the size and scope of your management system based on the needs of your mining operation.

For more information on Mining Technology & Autonomy products, visit cat.com/minestar.

Fleet

With real-time machine tracking, assignment and productivity management, Fleet gives you a comprehensive overview of all your operations. Fleet enhances the management of all types of equipment operations and allows you to easily drill down for more detailed views and analysis. You can generate reporting on selectable groups of assets, equipment on a particular site or even individual machines.

Fleet works with data from all types of assets and equipment — including off-highway trucks, wheel loaders, motor graders, wheel dozers, shovels, light duty vehicles and equipment from other manufacturers — helping you reduce costs per ton, enhance productivity and boost overall site profitability.

Fleet is comprised of five capability packages, which can be purchased and configured based on a mine's particular needs.

- **Production** — Provides real-time visibility of production operations, delivers improved shovel loading performance and increases payload predictability.
- **Position & Material** — Monitors material movement and type, alerts operators and planners of misroutes to ensure material is moved to the proper location. Also monitors machine location for the entire fleet and incorporates playback function to analyze dump movement and haul road congestion.
- **Assignment & Optimization** — Schedules and assigns equipment, maximizes production and shovel utilization, minimizes truck wait time and manages shift changes and fueling.
- **Data Share** — Allows Fleet to share data made available via the licensed capability packages with other applications such as data reporting systems and position monitoring systems via an industry standard interface.

Fleet provides a proven solution suite based on a single trusted set of data for real-time KPI and for standard and ad-hoc reports. It provides the mine with information to:

- Identify and quantify performance improvement opportunities (within and post shift)
- Develop strategies to capture performance improvement initiatives
- Assign equipment and fleets for maximized production or achievement of material management goals. Capability scales from simple assignment to full truck assignment with linear programming to ensure maximal flexible loader, truck and material capacity utilization
- Blend materials in order to meet preparation plant quality, tonnage and timing requirements
- Track machines and materials to ensure correct delivery of materials from sources to planned sinks and to monitor equipment routing
- Manage operators (licensing, shift allocation and rostering)
- Manage equipment fluids and tires
- Track equipment productivity capability, consumption and variance
- Monitor equipment health including alarms and sensor channel monitoring, pre-start checklists
- Determine “what if” impacts of making specific changes to the product plan

Cost reduction of 10% and greater can be achieved and sustained using Fleet. Cost reductions are typically realized through reduced equipment, manning, lower fuel and service requirements, while achieving the same levels of productivity.

Terrain

Terrain enables high-precision management of drilling, dragline, grading and loading operations through the use of advanced guidance technology. It increases machine productivity and provides you real-time feedback for improved efficiency.

Along with providing detailed in-cab machine guidance and machine positional information for equipment operators, Terrain makes a wealth of data available to mine managers and site planners — including up-to-the-minute machine location and operational status, progress toward completion of work plans and more.

Terrain gives machine operators the real-time guidance they need to do their jobs more safely and efficiently, while providing mine site managers with timely information and advanced tools to help them increase mine productivity, output production and profitability.

Terrain capability packages include:

- **Productivity** — Productivity allows the mine to track and analyze machine utilization and productivity by machine type and operator. Reporting tools generate information on machine utilization, timelines, operator productivity and other parameters to help identify and correct operational inefficiencies. It also enables the assignment of job tasks to grading and loading tools. Operators can even request the creation and assignment of a task to another operator (such as clean-up a spill). The information about each task is tracked and stored for reporting purposes.
- **Position & Material** — The Position & Material capability package allows machines to share position and job status information both on-board and in the office. This knowledge helps reinforce safe operating practices when working in close proximity. The Position & Material capability package also enables machine-to-machine cut and fill status sharing within grading and loading applications in real-time including sharing cut/fill information from draglines to dozers.

- **Data Share** — Allows Terrain to share data made available via the licensed capability packages with other applications such as competitive fleet management systems, data reporting systems, and position monitoring systems via an industry standard interface.
- **Multi-Site** — Allows for management of multiple Terrain-equipped sites from a single control center. By licensing the optional Multi-Site package at each mine, customers can monitor and manage work activities for multiple mines based on their universally defined user access permissions.

Terrain for Drilling

Terrain for drilling is designed for installation on electric, hydraulic rotary blasthole, and articulated drills. It provides production and performance monitoring, strata recognition and GNSS guidance. Provided as a field retrofit to machines already operating at mine sites, Terrain uses on-board computing integrated with sensors to monitor critical machine performance characteristics. System modules help the operator and site managers enhance drill performance and improve the drilling and blasting operation.

Production offers a graphical user interface to provide the operator with immediate feedback on drilling productivity and performance. The product minimizes operator input by an array of sensing hardware to detect:

- Hole depth
- Reaching target depth
- Steel changes

Strata Recognition analyzes the monitored drilling variables in real-time, determining variability in the hole geology. The different strata horizons are presented on the display. The system provides useful and concise information from the start of drilling — not large amounts of raw data that typify traditional drill monitoring systems. A Blastability Index is determined by the Strata Module and approximates the hardness of the ground. The hole loading requirements and ore grindability predictions are then based on measured rock hardness enabling improved blending and optimized mill through put rates.

Combining Production with Strata Recognition logs:

- Bit rotary speed
- Penetration rate
- Depth
- Rotary torque or pressure
- Pull-down pressure
- Bailing air pressure

Drilling practice, efficiency and productivity can then be analyzed and assessed.

Guidance adds high precision GNSS to help precisely position a drill on a blast pattern without the need for surveying or staking. Guidance uses a moving map display that shows the 3D (Northing, Easting and Elevation) of the drill and drill bit relative to the designed position of the blastholes. Once the drill is positioned and leveled over a hole, the system automatically determines collar elevation and then calculates the designed target depth. Guidance improves the drill's production and utilization, and the operator's ability to drill to the plan. This leads to better rock fragmentation for easier loading. Since holes are drilled to the correct elevation leading to a flatter post-blast surface, the result is smoother pit floors. This helps eliminate rework, enhances the mobile equipment's performance and reduces its wear and tear.

Terrain for Draglines

Terrain for Dragline provides real-time monitoring and reporting of dragline operations. By combining GNSS and production monitoring data, the system empowers the mining office to plan and control operations. It records the complete, detailed data associated with each load cycle.

The system gives the operator the design plan and real-time position of the dragline relative to the plan in 3D. It also monitors, displays, and logs various parameters from the machine and site.

- **Production Monitoring** — Production Monitoring provides real-time tracking and reporting of dragline operation results. When coupled with GNSS, Production Monitoring empowers miners to plan and control operations. The unparalleled geo-referenced production monitoring capability also records detailed data for subsequent analysis and reporting. Unlike traditional monitoring systems, Terrain for draglines records the complete, detailed data associated with each load cycle. The cycle data is not averaged or filtered, which means that the full data set remains available for additional querying.
- **3D Bucket Positioning** — This feature expands the basic GNSS navigation and Production Monitoring to provide the operator with a plan and profile view of the dragline and cut being excavated. The profile view can also include the bench, cut, beginning locations and final locations.
- **Load Weighment** — Terrain for draglines determines the payload weight during the swing to dump cycle. The load weighment feature calculates running and total shift productivity in actual tons in addition to a theoretical volume. Accurate payload information allows for a more precise measure of true machine productivity.
- **Boom Stress Monitoring** — Boom failure is a catastrophic event for a dragline. Terrain for draglines interfaces with third party boom stress monitoring systems to display information that the operator can use to minimize boom stress. Time-stamped data is recorded and logged enabling the mine office to manage boom life and operational practices.

Terrain for Grading & Loading

Terrain for grading & loading moves the material identification file and survey system into the machine, eliminating the need for survey stakes or pin flags. A touch screen monitor displays the location of pit boundaries, material type, bench height, and design grade, eliminating operator guesswork. With material types and locations displayed, ore identification and recovery are optimized.

The system is an ideal tool for mine planning, engineering, surveying, grade control and production monitoring applications. For example it can be used for:

- Haul road and bench construction and maintenance
- Production dozing
- Leach pad construction and maintenance
- Reclamation
- Task List Management
- Ore grade control and material identification
- Coal load out terminals

The system can be used on scrapers, loaders, dozers, shovels, motor graders, hydraulic excavators and track-type tractors.

Terrain now features a mobile application for use in light vehicles. Mine supervisors can log in from a laptop or tablet to view progress updates from nearby machines, know the precise location of all Terrain-equipped machines, assign tasks and validate design plans without having to drive back to the mine office, improving the efficiency of your operations. Updates made on the mobile application are sent back to the office software and then communicated to the applicable machine on-board system in near real-time.

Detect

Operators often cannot see if another machine or vehicle is too close for safe operation. Detect helps alleviate this potential safety hazard and can also be configured to provide valuable information about site conditions and other assets working in the area.

At the most basic level, Detect enhances your operators' awareness of the immediate environment around their equipment. A simple touch screen display alerts operators when radars indicate that objects have entered critical areas near the machine. The system allows a quick visual check of these areas whenever the operator wants one.

Additional capability packages enable Detect to alert the operator to pre-programmed avoidance zones, known site hazards and speed limits. Positional information from Detect can also provide valuable feedback to central office systems and mine site managers.

Detect capability packages include:

- **Vision** — Vision offers multiple camera capabilities, allowing operators to select the view or views they need on the in-cab display to see what is happening close to their machines.
- **Object Detection** — Object Detection adds radars while reducing areas of limited visibility and increasing perimeter awareness. This robust system is scalable to site needs and machine types, providing optimal awareness around equipment.
- **Proximity Awareness** — Proximity Awareness adds GNSS capabilities allowing Detect to display the locations of other equipment at all times. It also allows pre-programmed information — such as avoidance zones, hazards and speed limits — to be displayed in the cab. Incidents are captured in the office and are available for reporting and playback.
- **Personnel** — Personnel enhances safety of longwall operations through the use of locator tags. Individuals wearing tags are identified via programmed information such as ID and job role. The tags work with the roof support control system to stop movement if the presence of a tagged individual is in close proximity to moving equipment.

Vision

Vision for surface equipment offers multiple camera capabilities, allowing operators to manually select the view or views they need on the in-cab display to see what is happening close to their machines. Certain Vision kits are configurable for manual or rotating camera views. In underground applications, cameras are able to identify people and can follow them as they move along the working face. Built-in intelligence capabilities enable the system to span multiple cameras and combine images to create a continuous, real-time view of tracked personnel.

Object Detection

Object Detection is designed for machines ranging from large mining and quarry trucks to machines such as wheel loaders and motor graders. This robust system builds on Vision by adding radars to provide optimal awareness around the machine and notification when an object is detected. With both audible and visual indications, Object Detection helps prevent work area injuries caused by limited awareness. Using a combination of radars, cameras, and a high-resolution touch screen display, operators can view the areas immediately surrounding their machine, helping to prevent collisions and accidents.

Object Detection is highly integrated with the specific machine configuration to optimize radar and camera coverage. The system has been calibrated to provide appropriate fields of view and range. Unlike basic camera systems, Object Detection provides operators with audible and visual types of warnings that enable the operator to make informed decisions when moving or operating the machine. This system alerts the operator when an object is in close proximity so they can decide if action needs to be taken to avoid it.

Proximity Awareness

Proximity Awareness is a GNSS based system which tracks machines and light vehicles, allowing operators to view other machine locations and provide proximity based alarming.

The system is highly configurable allowing customers to define areas around the machine along with values that determine projected path of travel. Filters can be set to reduce alarming where machines naturally come in close proximity as part of their normal operations such as loading. The filters can be defined to eliminate audible alarming except for the most critical proximity zones. System flexibility allows customers to tailor proximity warnings to their site needs.

Onboard, the in-cab display shows a mine map indicating the position of the operator's machine in relation to others nearby. Zones are displayed on the map and operators are notified when they enter restricted areas or exceed specified speed limits. The display shows when two or more machines' projected paths of travel intersect providing warning of a potential collision.

The office application provides system administrative functionality such as the creation and maintenance of operators, machines, avoidance zones, hazards, and speed limits. Users can create personal desktop views to see information that is important to their job. Incident Management allows the capture of proximity, speeding and zone violations which can be played back for reconstruction.

Personnel

In underground applications, Personnel utilizes individual locator tags to identify people working at the face. This valuable information about the location and job role of tagged personnel is communicated via a high speed network so you always know where your people are working in proximity to moving equipment. It can automatically halt operations when unauthorized people enter restricted areas, while allowing service and maintenance personnel to work as required around operating equipment.

Fatigue and Distraction Management

Fatigue, sleepiness and distraction impact each of us every day and losing focus on a mine site can have serious consequences. However, this risk can be managed and mitigated through a comprehensive Fatigue Risk Management System (FRMS) that incorporates all layers of protection against fatigue. These layers of protection include:

- Site fatigue assessments
- Training and education on managing fatigue for individuals, managers and supervisors
- Technology change management
- 24/7 monitoring
- Schedule/roster analysis and optimization

Caterpillar is the sole provider of a complete solution that brings visibility to risk factors never seen before and applies root cause data to a continuous improvement process that delivers sustainable culture change.

With specialized in-cab equipment that alerts an operator when a fatigue or distraction event is detected and data monitoring to identify risk trends, Caterpillar can help you prevent incidents in the moment and give line of sight to a host of factors that influence safety and operational performance. We also offer safety management consulting and training to help you build and sustain a culture that supports your fatigue management system.

Health

Health delivers critical event-based machine condition and operating data for your entire fleet. It includes comprehensive, proactive health and asset monitoring capabilities, with a wide range of diagnostic, reporting tools, analytics and recommendations. The Health capability set now includes the powerful features of Cat Equipment Care Advisor providing a comprehensive suite of condition monitoring technologies for any customer type.

By identifying many types of potential equipment problems before failure, Health works to minimize unscheduled downtime and productivity loss. Plus, it helps keep your operating costs in check by streamlining service and maintenance management and scheduling. Health offers universal functionality that works with virtually any mine site asset, including off-highway trucks, wheel loaders, motor graders, wheel dozers, shovels and light-duty vehicles, as well as equipment from other manufacturers.

Key benefits of Health include:

- Saved component failures
- Extended component life
- Reduced phantom breakdowns
- Full fleet health monitoring
- Efficient data analysis
- Improved maintenance practices
- Combines equipment and application information from multiple sources, applies advanced analytics and incorporates Cat dealer expertise
- Results in early detection of issues with equipment
- Allows dealers and customers to be proactive in maintenance repair and component replacement decisions
- Automates and tracks recommendations through the repair workflow process
- Promotes knowledge sharing (across dealers and Caterpillar factory experts)

Command

Combining the Fleet, Terrain, Detect and Health capabilities of Cat MineStar, Command enables you to implement remote control, semi-autonomous or fully autonomous mining equipment systems for dozing and underground operations.

Taking advantage of proven technologies, as well as significant advances in remote sensing and guidance, Command helps you work more safely and productively in a wide range of harsh or challenging environments. And Command systems are proven to work safely and seamlessly with other mine site activities, equipment and personnel.

Command for Dozing

Command for dozing enables machine operation from a safe location with the operator removed from the cab. This system enhances operator safety by limiting exposure to full body vibration, dust and sound, and slips, trips and falls from machine ingress/egress. The machine can be operated by either an over the shoulder operator console or a seated operator station for longer term operations. Either system utilizes line of sight communications for near machine operation. This system is integrated with engine, implement, and power train controls. Safety controls are built in which stop the machine in case of the loss of radio, transceiver, or ECM communications. The machine will also stop in the event the operator console is tipped. Additional protection features include the use of auto-brakes when in neutral and engine over-speed protection. Perhaps the most unique feature is the integration with the Terrain avoidance zone functionality, which prevents the machine from entering predefined avoidance zones.

Benefits of Command for dozing include:

- Enables control of machine from safe location when operating in hazardous conditions.
- Operator exposure to dust, noise and vibration can be minimized when operating remotely.
- Numerous emergency stop functions available in the following scenarios:
 - Operator Console is tipped.
 - Off-board transceiver loses power.
 - Radio communications are lost.
 - Communication to on-board transceiver or any electronic control module is lost.
- AutoBrake feature prevents machine from coasting while not being controlled.
- Avoidance Zone (optional) prevents a remotely controlled machine from entering predefined avoidance zones or 3-dimensional surfaces.
- AutoRetarder enables engine over-speed protection.
- Multiple emergency shutdown switches engaged in the cab, on the Operator Console, in the ground-level service center
- Meets ISO 15817 standards
- Meets AS/NZS 4240

Applications

- Machine recovery
- Unstable footings
- Aggressive ripping
- Misfires
- Stockpiles
- Bench slides
- Steep slopes

Command for Underground

Developed out of the need to reduce human exposure to injury, the system removes the operator from dangerous situations and allows them to work in a more comfortable, ergonomic environment. The system uses technology to automate and enhance operations, by enabling semi-autonomous control of Cat LHD's. Command for underground will increase productivity and make a measurable impact on your mine's bottom line.

Command for underground consists of four major sub-systems that support the functionality of the system.

Operator Station

The Operator Station allows machines to be operated from an ergonomically designed seat in a variety of locations. The operator can safely operate the machine from a mine control room or mobile office, either above or underground. This removes the operator from potentially dangerous environments in the mine drives underground. The Operator Station consists of a computer, three monitors, a seat and two joysticks; one controlling the movement of the machine, the other controlling the bucket.

Machine Automation System

The Machine Automation System consists of the on-board hardware components that make the Command for underground system function. LADAR, cameras, lights, sensors, antennas, and control modules combine to create a system that provides safety and productivity for your underground mining operation.

Area Isolation System

Ensures that personnel cannot enter or equipment cannot leave the operations area while the machine is in autonomous mode. The operator has the ability to arm and disarm the system to compensate for changing business needs. A barrier control panel is located at each entry to the operations area. These are connected to barriers to ensure the area is secure. The status of each barrier control panel is reported to the programmable logic controller via the Local Area Radio Network (LARN). The programmable logic controller then determines whether the Operations Area should be armed.

Local Area Radio Network (LARN)

The LARN is a wireless Ethernet data network that enables communication between the machine and the Operator Station. The network uses the 802.11 b/g protocols and requires exclusive use of the 2.4 GHz RF spectrum. Signals from the Machine Automation System roam between LARN antennas as the machine moves within the operations area. The signals work primarily over line-of-sight, but can reach a short distance around corners. Video images and data are sent via the LARN.

Command for Longwall

Command for longwall automates Cat plows for enhanced safety. No operator is required at the longwall face itself. Operation can be controlled from a central control station either underground — for example, at the head gate entry — or on the surface, so operators can work remotely in a dirt- and dust-free area. The outrigger steering system provides vertical horizon control. Steering is normally controlled manually, but can be automated. Shields are positioned to suit the longwall's geology and normally advance automatically with the cutting action of the plow.

- **Advanced Low Seam Longwall System:** Combines high installed power with unique features like overload protection, horizon control and incremental plowing.
- **Lowest Total Cost of Ownership:** Setting the standard for mining coal seams below 1.8 meters (90 in).
- **Industry's Most Advanced Remote Control System:** No operator required in the face during operation.
- **No Out-of-Seam Dilution:** Positive environmental impact by minimizing refuse requiring disposal.
- **Technology that Delivers Sustainability:** Opens new coal reserves that were previously classified as uneconomical to mine.

CONTENTS

Selection, Application, Maintenance	32-1
Tire Construction	32-2
Bias Ply	32-2
Radial Ply	32-3
Tire Types	32-3
Tire Size Nomenclature	32-3
Code Identification for	
Off-Highway Tires	32-4
Manufacturers' Designations:	
Firestone, Goodyear/Dunlop,	
Bridgestone, Michelin	32-5
Titan, Triangle, Eurotire, Yokohama	32-10
Nokian, Belshina, Pirelli, Double Coin	32-13
Radial Tire Identification:	
Michelin	32-15
Goodyear	32-16
Bridgestone	32-17
Ton-Kilometer Per Hour Rating System	32-18
Tire Drive-Away Recommendations	32-19
TKPH Ratings:	
Goodyear Tires	32-20
Bridgestone Tires	32-31
Michelin Tires	32-39
Triangle Tires	32-50
Eurotire Tires	32-52
ISO Load Index Speed Symbol:	
Michelin Tires	32-47
Tire and Rim Association Ratings	32-53
Tire Selection	32-53
Guide	32-55
Standard Cold Inflation Pressures	32-56
Liquid Ballasting Table	32-77

SELECTION, APPLICATION, MAINTENANCE

Proper tire selection, application and maintenance continue to be the most important factors in earthmoving economics. Wheel tractors, loaders, scrapers, trucks, motor graders, etc. are earthmoving equipment whose productivity and payload unit cost may depend more on tire performance than any other factor.

Off-the-road tires must operate under a wide variety of conditions ranging from dry "potato dirt" through wet severe shot rock. Speed conditions vary from less than 1 mph average to 72 km/h (45 mph). Gradients may vary from 75% favorable to 30% adverse. Climatic conditions, operator skills, maintenance practices, etc. all may have a profound effect on tire life and unit costs.

Although one specific tire construction may be acceptable in a variety of applications, no one tire can meet all requirements on any one machine and perhaps not even one job. The many differences in tire requirements on earthmoving machines have resulted in a wide variety of tread and casing designs being made available. The optimum tire selection for a specific machine on a given job should be a joint decision between the user and tire supplier. Several tire manufacturers have technical and application representatives in the field for proper guidance in tire selection.

When job conditions change, it may be desirable to select a different tire configuration to meet the new requirements.

TIRE CONSTRUCTION

The pneumatic tire is essentially a flexible pressure vessel utilizing structural members (nylon, steel cable, etc.) to contain the hoop tension resulting from the inflation pressure. Rubber is utilized as a protective coating and sealant over the structural members and makes up the tread pattern which provides the wearing medium at the ground interface. The following brief explanation of the various tire constructions will assist you in selecting tires for your specific application.

Two distinct tire constructions approved on all Cat[®] machines are the BIAS PLY and RADIAL PLY tires. Radial tires are designated by an “R” while a “-” represents a Bias constructed tire. For example, a 45/65-45 tire would be of Bias construction and a 45/65R45 would be of Radial construction. The following is a brief explanation of the principal features of these two constructions.

Bias Ply

1. *Beads* — The tire beads consist of steel wire bundles (3 or 4 in larger tires) which are forced laterally by tire inflation pressure to wedge the tire firmly on the rim’s tapered bead seat. The nylon plies tie into the bead bundles. The forces inherent in the tire are transmitted from the rim through the bead bundles into the nylon.
2. *Body plies* — Layers of rubber-cushioned nylon cord comprise the tire casing. Alternating plies of cord cross the tread centerline at an angle (bias). The term “ply rating” is an index of tire strength and not the actual number of tire plies.

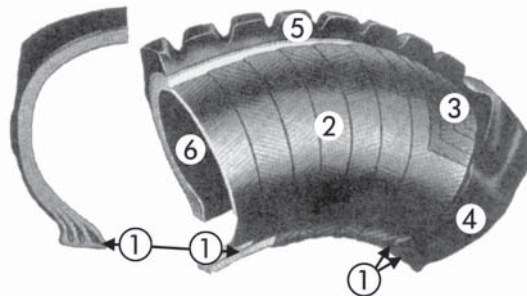

Bias Ply Construction

3. *Breakers or tread plies* — These, if used, are confined to the tire’s tread area and are intended to improve casing strength and provide additional protection to the body plies. Some “work” tires employ steel breakers or belts to further protect the casing.
4. *Sidewalls* — These are the protective rubber layers covering the body plies in the sidewall.
5. *Tread* — The wearing part of the tire that contacts the ground. It transmits the machine weight to the ground and provides traction and flotation.
6. *Inner liner* — This is the sealing medium that retains the air and, combined with the “O” ring seal and rim base, eliminates the need for inner tubes and flaps.
7. *Tubes and flaps (not shown)* — Required if the tire is not of tubeless construction with an inner liner.
8. *Undertread* — Protective rubber cushion lying between tread and body ply.

Radial Ply

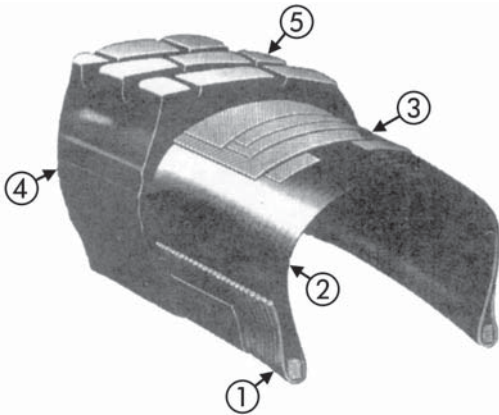

Radial Ply Construction

1. *Beads* — A single bead bundle of steel cables or steel strip (spiraled like a clock spring) comprise the bead at each rim interface.
2. *Radial casing* — This consists of a single layer or ply of steel cables laid archwise (on the radian) bead to bead.
3. *Belts* — Several layers or plies of steel cable form the belts which underlie the tread area around the tire circumference. The cable in each belt crosses the tread centerline at an angle with the angle being reversed from the preceding belt.
4. *Sidewalls*.
5. *Tread*.
6. *Undertread* — Protective rubber cushion lying between tread and steel belts.

Bias and Radial Tire Advantages

	Bias	Radial
Tread Life		X
Heat Resistance		X
Cut Resistance — Tread		X
Cut Resistance — Side Wall	X	X
Traction		X
Flotation		X
Stability	X	
Fuel Economy		X
Repairability		X

TIRE TYPES

Off-the-road tires are classified by application in one of the following three categories:

1. *Transport tire* — For earthmoving machines that transport material such as trucks and wheel tractors.
2. *Work tire* — Normally applied to slow moving earthmoving machines such as graders and loaders.
3. *Load and carry* — Wheel loaders engaged in transporting as well as digging.

TIRE SIZE NOMENCLATURE

Tire size nomenclature is derived from the approximate cross section width and rim diameter typically in the format of Tire Width, Aspect Ratio, and Rim Diameter (example: 45/65-45). Available tire types include:

1. A wide base tire has a section height to section width ratio in the range of 0.83. As an example, a 29.5-25 tire has an approximate cross section width of 749 mm (29.5") (first number) and a rim diameter of 635 mm (25") (second number).
2. A conventional tire has a section height to section width ratio in the range of 0.96. As an example, a 24.00R35 tire has an approximate cross section width of 610 mm (24") (first number) and a rim diameter of 889 mm (35") (second number).
3. A low profile tire has a section height to section width ratio in the range of 0.65. As an example, a 45/65-45 tire has an approximate cross section width of 1143 mm (45") (first number), a 65% aspect ratio designated as 65 (second number), and a rim diameter of 1143 mm (45") (third number).

If designated 45/65 R39, then the R denotes radial construction.

When comparing a wide base tire to a standard base tire, a larger first number on a wide base tire with the same rim diameter does not mean the wide base is larger in overall diameter. For example, the 18.00-25 conventional tire is larger in diameter than the 20.5-25 wide base tire. The 18.00-25 is comparable in overall diameter to the 23.5-25 wide base tire.

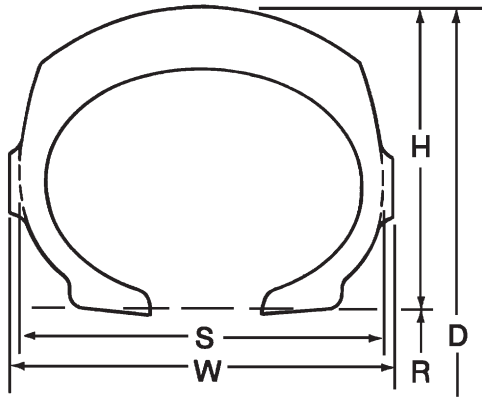

Tire cross-section

- D = Tire Overall Diameter
- R = Nominal Rim Diameter
- H = Tire Section Height
- S = Tire Section Width
- W = Tire Width (includes ornamental ribs)
- $\frac{H}{S}$ = Aspect Ratio

CODE IDENTIFICATION FOR OFF-HIGHWAY TIRES

The tire industry has adopted a code identification system to be used for off-the-road tires. This identification system will reduce the confusion caused by the trade names for each type of tire offered by each tire manufacturer. The industry code identification is divided into six main categories by types of service as follows:

- C** — Compactor Service
- E** — Earthmover Service
- G** — Grader Service
- L** — Loader and Dozer Service
- LS** — Log-Skidder Service
- F** — Industrial
- R** — Agricultural Tractor
- I** — Agricultural Implement

The sub-categories are designated by numerals, as follows:

Code Identification		% Tread Depth
Compactor		
C-1	Smooth	100
C-2	Grooved	100
Earthmover		
E-1	Rib	100
E-2	Traction	100
E-3	Rock	100
E-4	Rock Deep Tread	150
E-7	Flotation	80
Grader		
G-1	Rib	100
G-2	Traction	100
G-3	Rock	100
G-4	Rock Deep Tread	150
Loader and Dozer		
L-2	Traction	100
L-3	Rock	100
L-4	Rock Deep Tread	150
L-5	Rock Extra Deep Tread	250
L-3S	Smooth	100
L-4S	Smooth Deep Tread	150
L-5S	Smooth Extra Deep Tread	250
L-5/L-5S	Half Tread Extra Deep	250
Log-Skidders		
LS-1	Regular Tread	100
LS-2	Intermediate Tread	125
LS-3	Deep Tread	150
HF-4	Extra Deep Tread	250
Industrial		
F-3	Traction Tread	
Agricultural Tractor		
R-1	Regular Tread	
R-3	Shallow Tread	
R-4	Industrial Tractor	
Agricultural Implement		
I-3	Tractor Tread	

Tire and Rim Assoc. Code	Tread Type	FIRESTONE	GOODYEAR/ DUNLOP*	BRIDGESTONE	MICHELIN
Compactor					
C-1	Ribbed (Smooth Surfaces)		SMC-1A	RR	X LISSE COMPACTEUR
C-2	Traction (Regular)			AL2	
Earthmover					
E-1	Ribbed (Smooth Surfaces)		HRR-1A XDR-1A		
E-2	Traction (Regular)	SGG LD (E2/L2)	Custom HI-MILLER (CHM) MC-1A RL-2F (E2/G2) SG Lug SGL-2A SGL E/L-2A (E2/G2/L2)	VFT VGT VHB VHS VKT (E2/G2/L2) VSB	X-CRANE AT XGC XMH S XR B (E2/E3) XR C4 (E2/E3) XSNOPLUS 170E XTLA (E2/G2/L2) XVC
E-3	Rock (Regular)	E67 SRG LD	AT-2A (E3/L3) GP-2B (E3/G3/L3) GP-3D (E3/L3) HRL-3A (E3/L3) HRL-3B HRL-3C HRL-3F HRL D/L-3A (E3/G3/L3) HRL E/L-3A (E3/G3/L3) RL-2+ (E3/G3/L3) RL-3 RL-3+ RL-3F (E3/L3) RL-3J (E3/L3) RT-3A+ RT-3B (E3/L3) SHRL (E3/L3) SHRL 8 TL-3A+ (E3/L3) UMS D/L-3A (E3/L3) UMS-3A (E3/L3) WRL-3A (E3/L3)	RL (E3/G3/L3) VEL VL2 (E3/L3) VLT VMT VRD VRF VRL WL	XAD 65-1 XADN XDM C4 XDR S XK A (L3 for 25" Rim) XMS XR B/XRC4 (E2/E3) X-STRADDLE X-TRACTION S XTS

*Dunlop brand indicator.

Tires | Manufacturer's Designation

Tire and Rim Assoc. Code	Tread Type	FIRESTONE	GOODYEAR/ DUNLOP*	BRIDGESTONE	MICHELIN
Earthmover					
E-4	Rock (Deep Tread)	SRG DT	GP-4B GP-4C (E4/L4) GP-4D (E4/L4) HRL-4A HRL-4B MRL-4B MRL-4D MRL-4F NRL D/L-4A (E4/L4) RL-4 RL-4A RL-4B RL-4F RL-4C RL-4H RL-4H II RL-4J RL-4J II RL-4L RL-4M+ RT-4A RT-4A+	ELS2 L317 RLS (E4/L4) VELS VLTS (E4/L4) VMTP VMTS (E4/G4) VRDP VREP VRLS VRPS VRQP VSNT (E4/L4) VZTP VZTS	X [®] SUPERTERRAIN AD XDM™ B XDR™ XDR™ 2 XDT™ X-HAUL [®] XKD1™ X-Quarry [®] /X-Quarry [®] S XRS™ X-TRACTION™
E-5	Rock (Extra-Deep Tread)				
E-7	Flotation		EAW-7A SAW-7A SHY-7A SRB-7A SRB-7B	SCP2 VSJ	
Grader					
G-1	Ribbed (Smooth Surfaces)		AWG-1A RBG-1A SMG-1A		
G-2	Traction (Regular)	SGG RB (G2/L2)	AS-3A (G2/L3) ASG-2A RL-2F (E2/G2) SG-2B SGG-2A SGG-2A SG SGL D/L-2A (G2/L2) SGL E/L-2A (E2/G2/L2) SP-T9* (G2/L2)	FG (G2/L2) VKT (E2/G2/L2) VSW (G2/L2) VUT (G2/L2)	XGLA2™ (G2/L2) XSNPLUS [®] M&S (G2/L2) XTLA™ (E2/G2/L2)
G-3	Rock (Regular)		GP-2B (E3/G3/L3) HRL E/L-3A (E3/G3/L3) RKG-3A RKG-3C RL-2+ (E3/G3/L3)	RL (E3/G3/L3)	XR™ A (G3/L3)
G-4	Rock (Deep Tread)	SRG DT RB	SGG-4B		
G-5	Rock (Extra-Deep Tread)		HRL D/L-5A		
G-5S	Smooth (Extra-Deep Tread)		SMO D/L-5A (G5S/L5S) SMO D/L-5B (G5S/L5S)		

*Dunlop brand indicator.

Tire and Rim Assoc. Code	Tread Type	FIRESTONE	GOODYEAR/ DUNLOP*	BRIDGESTONE	MICHELIN
Loader and Dozer					
L-2	Traction (Regular)	SGG LD (E2/L2) SGG RB (G2/L2)	E91* E91-2* SGL D/L-2A (G2/L2) SGL E/L-2A (E2/G2/L2) SP-T9* (G2/L2)	FG (G2/L2) VKT (E2/G2/L2) VSW (G2/L2) VUT (G2/L2)	XF™ XGLA2™ (G2/L2) XSNOPLUS® M&S (G2/L2) XTLA™ (E2/G2/L2)
L-3	Rock (Regular)	SRG LD	AS-3A (G2/L3) AT-2A (E3/L3) ELV-3A (I3/L3) GP-2B (E3/G3 /L3) GP-3D (E3/L3) HRL D/L-3A (G3/L3) HRL D/L-3B HRL D/L-3C HRL E/L-3A (E3/G3/L3) HRL-3A (E3/L3) RL-2+ (E3/G3/L3) RL-3F (E3/L3) RL-3J (E3/L3) RT-3B (E3/L3) SHRL (E3/L3) SHRL D/L TL-3A+ (E3/L3) UMS D/L-3A (E3/L3) UMS-3A (E3/L3) WRL-3A (E3/L3)	RL (E3/G3/L3) VCH VJT VL2 (E3/L3) VTS	STABIL'X® X STACKER™ STABIL'X® XZM™ 2 STABIL'X® XZM™ STABIL'X® XZSL® XHA™ XHA™ 2 XK® A (E3 for 24" Rim) XLD® L3 XR™ A (G3/L3) XRDN™ A
L-4	Rock (Deep Tread)	DLDT SRG DT LD	AMS D/L-4/15C AMS-4/5A DMS D/L-4/15C DRL-4/15C GP-4C (E4/L4) GP-4D (E4/L4) HRL D/L-4/15C HRL D/L-4A HRL D/L-4B HRL D/L-4G NDL D/L-4/15C NRL D/L-4/15C NRL D/L-4A (E4/L4) NRL D/L-4D RL-4D RL-4K SHRL XT D/L	NL RLS (E4/L4) VCHD VCHS VLTS (E4/L4) VSNL VSNT (E4/L4)	XLD® D1

*Dunlop brand indicator.

Tires | Manufacturer's Designation

Tire and Rim Assoc. Code	Tread Type	FIRESTONE	GOODYEAR/ DUNLOP*	BRIDGESTONE	MICHELIN
Loader and Dozer					
L-5	Rock (Extra-Deep Tread)	DLSDT SDT LD Duraforce MH	AMS D/L-5/15C AMS D/L-5/8H AMS D/L-5/9A AMS-5/11F AMS-5/15C AMS-5/8F DMS D/L-5/15C DRL D/L-5A HRL D/L-5A (G5/L5) HRL D/L-5B HRL D/L-5C NDL D/L-5/15C NRL D/L-5/15C NRL D/L-5A RL-5K RT-5C SXT D/L SXT LDR	DL VSDL VSDT	X MINE® D2 XLD® D2
L-3S	Smooth (Regular)	PLTD Industrial	RL-3S (Smooth) SMO D/L-3A (Smooth)		
L-4S	Smooth (Deep Tread)	PLTD PLTD UMS	NSM D/L-4B SMO D/L-4A SMO D/L-4B SMO-4B		
L-5S	Smooth (Extra-Deep Tread)	PTLD Industrial PTLD UMS DLPT	NSM D/L-5B RL-5S SM-5A SMO D/L-5A (G5S/L5S) SMO D/L-5B (G5S/L5S) SMO D/L-5C SMO D/L-5D SMO-5A SMO-5B SMO-5C SMO-5D	STMS VSMS	XSM® D2+
L-6S	Smooth (Extra-Deep Tread)	DuraWaste			
L-5/L-5S	Rock/Smooth (Extra-Deep Tread)	HTLD			

*Dunlop brand indicator.

Tire and Rim Assoc. Code	Tread Type	FIRESTONE	GOODYEAR/ DUNLOP*	BRIDGESTONE	MICHELIN
Soil Compactor					
R-1	Ribbed (Smooth Surfaces)	Field and Road Performer 85 Radial 23 Radial 9100 Radial All Traction Super All Traction Super All Traction II Traction Field and Road			
R-3	Rock (Regular)	All Non-Skid Tractor Farm Service DIA Turf and Field	SFT105		
Log Skidder					
LS-1 LS-2	Intermediate	Forestry Special CRC Forestry Special Severe Service		TGS	
LS-3 HF-4	Deep Extra Deep				
Backhoe Loader					
F-3 I-3	Industrial Multiple-Rib Traction	Industrial Special All Traction Utility Power Implement Super Traction Loader	Laborer	YS2	
I-4 R-4	Industrial Drive Wheel, Industrial Tractor	All Traction Utility Duraforce RT	Industrial Sure Grip IT510 IT525 SG Lug		XMCL™ Power CL Bibload
Skid Steer					
SS	Regular		IT323 LS SGL SGL SS		
High Speed Crane					
MCS	Regular				

*Dunlop brand indicator.

Tires | Manufacturer's Designation

Tire and Rim Assoc. Code	Tread Type	TITAN	TRIANGLE	EUROTIRE	YOKOHAMA
Compactor					
C-1	Ribbed (Smooth Surfaces)				Y69 (C1/I4/L4S/L5S)
C-2	Traction (Regular)				
Earthmover					
E-1	Ribbed (Smooth Surfaces)				Y41
E-2	Traction (Regular)	TGD2 (E2/L2)	TB515 (E2/G2/L2) TB536 (E2/G2/L2) TB586 TM518 (E2/L2) TL508 (E2/L2)		Y103 (E2/G2/L2)
E-3	Rock (Regular)	007 MFT (E3/E4) CM100 Grizz 1000 LCM MXL (E3/L3) ND LCM ND LCM MCS SL 100 STL2+ STL3 Super Rigger XG-3	TB516 (E3/L3) TB526 TB598 (E3/L3) TL528 (E3/L3) TL559 TL568+	U-11 U-12	RB31 (E3/L3) RL31 (E3/L3) RT31 (E3/L3) Y529 Y565 Y67 (E3/G3/I3/L3)
E-4	Rock (Deep Tread)	007 MFT (E3/E4) CH 150 (E4/L4) CM 150 DTE4 DTH4 ND Super LCM Quarry Special CM 150 Super LCM	TB516S TB526S TB598S TL558S	DR004 LR004 (E4/L4) ETRAC ETRAC ADT EROCK U-11 U-12 U-14	RB41 RB42 RL42 RL45 (E4/L4) RT41 (E4/L4) Y522 (E4/L4) Y523 (E4/I4) Y523R/U Y530 Y567
E-5	Rock (Extra-Deep Tread)				
E-7	Flotation	Super Sand Flotation			Y65
Grader					
G-1	Ribbed (Smooth Surfaces)				
G-2	Traction (Regular)	Grader HD (G2/L2) HD 2000 II Loader Grader III (G2/L2) LSW G8L Super Grader (G2/L2) TG2 TGL2 (G2/L2) TGS2	TB515 (E2/G2/L2) TB536 (E2/G2/L2)		RT21 Y103 (E2/G2/L2)
G-3	Rock (Regular)				Y67 (E3/G3/I3/L3)
G-4	Rock (Deep Tread)				
G-5	Rock (Extra-Deep Tread)				
G-5S	Smooth (Extra-Deep Tread)				

Tire and Rim Assoc. Code	Tread Type	TITAN	TRIANGLE	EUROTIRE	YOKOHAMA
Loader and Dozer					
L-2	Traction (Regular)	Grader HD (G2/L2) Lift Rigger II Loader Dozer II Loader Grader III (G2/L2) Super Grader (G2/L2) TGD2 (E2/L2) TGL2 (G2/L2)	TB515 (E2/G2/L2) TB536 (E2/G2/L2) TM518 (E2/L2) TL508 (E2/L2)		Y103 (E2/G2/L3)
L-3	Rock (Regular)	LCM LD 100 MXL (E3/L3) ND LCM STL2+ (E3/L3) STL3 (E3/L3) Super Rigger (E3/L3)	TB516 (E3/L3) TB598 (E3/L3) TL528 (E3/L3)	F220	RB31 (E3/L3) RL31 (E3/L3) RT31 (E3/L3) Y526K Y575 Y67 (E3/G3/I3/L3)
L-4	Rock (Deep Tread)	CH 150 (E4/L4) CM 150 LD 150 LS 150 Super LCM		LR004 (E4/L4)	RL45 (E4/L4) RT41 (E4/L4) Y522 (E4/L4) Y545 Y67E
L-5	Rock (Extra-Deep Tread)	LD 250 LD 250 Belted	TL535S+ TL538S+ TL559S+	ETRAC WL U-54	Y524 Y524Z Y525
L-3S	Smooth (Regular)				
L-4S	Smooth (Deep Tread)	Super Smooth	TSMS		Y69 (C1/I4/L4S/L5S) Y69K (L4S/L5S) Y69U (L4S/L5S)
L-5S	Smooth (Extra-Deep Tread)	LD 250 Super Smooth LD 250 Super Smooth Belted LD 250 Super Smooth UGM Super Smooth	TSMS+		Y69 (C1/I4/L4S/L5S) Y69K (L4S/L5S) Y69U (L4S/L5S)
L-6S	Smooth (Extra-Deep Tread)				
L-5/L-5S	Rock/Smooth (Extra-Deep Tread)	LD 250 Half-Trac LD250 Half-Trac Belted			
Soil Compactor					
R-1	Ribbed (Smooth Surfaces)				
R-3	Rock (Regular)				
Log Skidder					
LS-1					
LS-2	Intermediate	Goodyear Logger Lug III Goodyear Logger Lug III HD			
LS-3	Deep				
HF-4	Extra Deep	Goodyear Logger Lug III Flotation			

Tires | Manufacturer's Designation

Tire and Rim Assoc. Code	Tread Type	TITAN	TRIANGLE	EUROTIRE	YOKOHAMA
Backhoe Loader					
F-3	Industrial Multiple-Rib	Contractor Goodyear Laborer Goodyear Multi Rib Industrial Front Tractor			
I-3	Traction	Contractor Contractor II Goodyear Sure Grip Implement Goodyear Sure Grip Lug Grizz LSW G2E TI422			Y532 Y543 Y67 (E3/G3/I3/L3) Y69PS Y92
I-4	Industrial				RL43 RR41 Y523 (E4/I4) Y69 (C1/I4/L4S/L5S)
R-4	Drive Wheel, Industrial Tractor	Goodyear IT510 Goodyear IT515 HS Goodyear IT520 Goodyear IT525 Goodyear IT530 Goodyear IT610 Grizz LSWG99F Industrial Contractor Industrial Sure Grip Industrial Tractor Industrial Tractor Lug Industrial Tractor Lug II			
Skid Steer					
SS	Regular				
High Speed Crane					
MCS	Regular				

Tire and Rim Assoc. Code	Tread Type	NOKIAN	BELSHINA	PIRELLI	DOUBLE COIN
Compactor					
C-1	Ribbed (Smooth Surfaces)				
C-2	Traction (Regular)				
Earthmover					
E-1	Ribbed (Smooth Surfaces)				
E-2	Traction (Regular)		F-92A (E2/E3/G2/L2) FBEL-199		REM-15 (E2/L2)
E-3	Rock (Regular)	Mine E-3	BEL-6 (E3/L3) BEL-51A BEL-160 F-92A (E2/E3/G2/L2) VF-76BM VF-166AM	RM94 RM95 RM99 RM100	REM-2 (E3/L3) REM-10 (E3/L3)
E-4	Rock (Deep Tread)	Armor Gard Mine Industrial Mine Nordman Mine E-4	BEL-102 BEL-112 BEL-153 BEL-156 BEL-162 BEL-170 BEL-172 BEL-174 BEL-180 BEL-182 FBEL-150 FT-115 FT-116AM2 FT-117	RM95 RM99	REM-9 REM-11
E-5	Rock (Extra-Deep Tread)				
E-7	Flotation				
Grader					
G-1	Ribbed (Smooth Surfaces)				
G-2	Traction (Regular)		F-92A (E2/E3/G2/L2) FBEL-247-1 (G2/L2)	PN12 (G2/L2) PN14 (G2/L2)	REM-1
G-3	Rock (Regular)		F-120		
G-4	Rock (Deep Tread)				
G-5	Rock (Extra-Deep Tread)				
G-5S	Smooth (Extra-Deep Tread)				

Tires | Manufacturer's Designation

Tire and Rim Assoc. Code	Tread Type	NOKIAN	BELSHINA	PIRELLI	DOUBLE COIN
Loader and Dozer					
L-2	Traction (Regular)	Forest Rider GRS Loader Grip Loader Grip 2 TRI Steel TRI Backhoe TRI 2 80/75/70/65 Series TRI 2 Extreme TRI 2 Extreme Steel	F-92A (E2/E3/G2/L2) FBEL-247-1 (G2/L2)	PN12 (G2/L2) PN14 (G2/L2)	REM-15
L-3	Rock (Regular)	Loader Grip 3	BEL-6 (E3/L3) BEL 26.42.38 BEL 32.48.75 F-170	RM94 RM99 RM100	REM-2 (E3/L3) REM-15 (E3/L3)
L-4	Rock (Deep Tread)	Armor Gard	FBEL-5 FBEL-283		
L-5	Rock (Extra-Deep Tread)			PN12 (G2/L2) PN14 (G2/L2)	REM-12 REM-18 REM-19
L-3S	Smooth (Regular)	Mine L-3S			
L-4S	Smooth (Deep Tread)		BEL-10M		
L-5S	Smooth (Extra-Deep Tread)	Mine L-5S Mine King L-5S Nordman Mine L-5S			
L-6S	Smooth (Extra-Deep Tread)				
L-5/L-5S	Rock/Smooth (Extra-Deep Tread)				
Soil Compactor					
R-1	Ribbed (Smooth Surfaces)		BEL-111		
R-3	Rock (Regular)				
Log Skidder					
LS-1					
LS-2	Intermediate	Forest King TRS LS-2 TRS LS-2 SF Excavator			
LS-3	Deep				
HF-4	Extra Deep				
Backhoe Loader					
F-3	Industrial Multiple-Rib				
I-3	Traction				REM-6
I-4	Industrial				
R-4	Drive Wheel, Industrial Tractor				
Skid Steer					
SS	Regular				REM-3
High Speed Crane					
MCS	Regular				REM-8

RADIAL TIRE IDENTIFICATION

Code Identification for Michelin Tires

All Michelin earthmover tires are radial construction, designated by the “X” marking. They contain a single steel radial ply with a series of steel belts placed around the tire’s circumference which reinforce and stabilize the tread.

Following are the tread designs currently available from Michelin with the different internal constructions depending on the application.

- Type A4** Particularly resistant to cuts, tread tearing and abrasion on very rough surfaces.
- Type A** Particularly resistant to cuts, tread tearing and abrasion at average speeds which are higher than those for A4 (above).
- Type B4** Compromise solution between abrasion resistance and average speed on rough surfaces (available in sizes 49 inch rim diameter and above).
- Type B** Higher resistance to internal heat generation on surfaces which are not particularly rough.
- Type C4** For running on long cycles at high speeds on well maintained roads.
- Type C** Very high resistance to high average speeds on long cycles run on well maintained roads.

The current combinations of tread patterns, construction, and tread depths offered, and primary TRA codes are:

Tread Design	Tread Compounds						Primary TRA Code(s)
	A4	A	B4	B	C4	C	
XDM™					X		E-3
XDM™				X			E-4
XDR™		X	X	X	X	X	E-4
XDR™ S				X	X		E-3
XDR™2		X	X	X	X	X	E-4
XDT™	X	X	X	X			E-4
XK®		X					E-3/L-3
XKD1™		X					E-4
XLD® D2		X					L-5
XMINE® D2		X					L-5
XMS™		X		X			E-3
XRDN™		X					L-3
XR™		X					G-3/L-3
XR™				X	X		E-2/E-3
XTLA™		X					E-2/G-2/L-2
X-TRACTION™	X		X	X			E-4

Since Michelin radial tires contain a single steel casing ply, they utilize the industry method of designating radial tire strength in terms of “stars.” Their system consists of a one star, two star, and three star rating as an indication of the tire’s carrying capacity. The one star is the lightest construction, generally used on work and slow moving transport machines. Two star tires are used on most medium and high speed transport machines. Three star construction provides the greatest carrying capacity for a given size and is only available in small standard base tires.

This combination of tread designs and types of construction provides a range of radial tires which cover most earthmoving applications. We recommend that in applying steel radial tires to your machines you provide all site condition data to the tire manufacturer. Obtain their recommendations as to which tire will provide the most economical operation.

Code Identification for Goodyear Radial Tires

All Goodyear steel radial earthmover tires have been designated *Unisteel* followed by a three or four digit alpha-numeric code that identifies the particular tread. For example, for a RL-2+, RL stands for Rock Lug and indicates that the upper sidewall has rock protection. The number in the code corresponds to the tire industry identification system (2-traction, 3-rock, etc). The fourth digit, if any, is used to designate tread design differences for the same basic tread type.

Following are the radial tread designs currently available from Goodyear with the compound and construction types depending on the application.

Compound Description	Compound Code
Heat Resistant	2
Standard Abrasion Resistant	4
Ultra Abrasion Resistant	6
Construction Description	Construction Code
Standard	S
Heavy Duty	H
Extra Heavy Duty	HW
Steel Breakers	J
Heavy Undertread	U
Low Angle Belts	SL

Tread Design	Tread Compounds			Primary TRA Code(s)
	2S	4S	6S	
AT-2A	X	X	X	E-3/L-3
GP-2B	X	X	X	E-3/G-3/L-3
GP-3D	X	X	X	E-3/L-3
GP-4B	X	X	X	E-4
GP-4B AT	X	X	X	E-4/G-4
GP-4C	X	X	X	E-4/G-4/L-4
GP-4D	X	X	X	E-4/L-4
RL-2+	X	X	X	E-3/G-3/L-3
RL-2F	X	X	X	E-2/G-2/L-2
RL-3	X	X	X	E-3
RL-3+	X	X	X	E-3
RL-3A	X	X	X	E-3
RL-3F		X		E-3/L-3
RL-3J	X	X		E-3
RL-4	X	X	X	E-4
RL-4A	X	X	X	E-4
RL-4B	X	X	X	E-4
RL-4C	X	X	X	E-4
RL-4F	X	X	X	E-4
RL-4H	X	X	X	E-4
RL-4H II	X	X	X	E-4
RL-4J	X	X	X	E-4
RL-4J II	X	X	X	E-4
RL-4K		X	X	L-4
RL-4M+	X	X	X	E-4
RL-5K		X	X	L-5
RM-4A+	X	X	X	E-4
RT-3A+	X	X	X	E-3
RT-3B			X	L-3
RT-4A	X	X	X	E-4
RT-4A+	X	X	X	E-4
TL-3A+	X	X	X	E-3/L-3

A star rating system instead of the ply rating system indicates the casing strength of radial tires. These symbols indicate the recommended inflation for a particular tire load. Following the star rating code is Goodyear's Custom Compound and Construction code. For a tire designated "2S" the 2 indicates a heat resistant compound and the S indicates standard construction. The higher the number the greater the abrasion and cut resistance with a corresponding lower TKPH/TMPH rating.

Code Identification for Bridgestone Radial Tires

The Bridgestone steel radial earthmover has been designated as V-Steel. Following are the radial tread designs currently available from Bridgestone with the compound and construction types depending on the application.

Bridgestone Compound and Structure Codes

1A	Standard
2A	Cut-Resistant
2V	Special Cut Resistant (Steel Breaker)
2Z	Special Cut Resistant (Side Steel Breaker)
3A	Heat-Resistant
E	Earthmover
G	Grader
D	Loader and Dozer
S	Logging

Tread Design	Tread Name	Tread Compounds				Primary TRA Code(s)
		1A	2A	2V	3A	
VEL	V-Steel E-Lug	X	X		X	E-3
VELS	V-Steel E-Lug S	X	X		X	E-4
VELSL	V-Steel E-Lug S				X	E-4
VFT	V-Steel F-Traction	X	X		X	E-2
VHS	V-Steel H-Service				X	E-2
VJT	V-Steel J-Traction		X			E-3/L-3
VKT	V-Steel K-Traction	X	X			E-2/G-2/L-2
VLT	V-Steel L-Traction	X	X			E-3/L-3
VLTS	V-Steel L-Traction S		X			E-4/L-4
VMT	V-Steel M-Traction	X	X		X	E-3/L-3
VMTP	V-Steel M-Traction Premium	X	X		X	E-4
VMTS	V-Steel M-Traction S	X	X		X	E-4/G-4
VRDP	V-Steel Rock Deep Premium	X	X		X	E-4
VREP	V-Steel Rock E-Premium	X	X		X	E-4
VRF	V-Steel Rock Fast	X			X	E-3
VRL	V-Steel R-Lug	X			X	E-3
VRLS	V-Steel R-Lug S	X	X		X	E-4
VRPS	V-Steel Rock Premium Service	X	X		X	E-4
VRQP	V-Steel Rock Quarry Premium		X			E-4
VSBL	V-Steel S-Block		X			E-2
VSDL	V-Steel D-Lug		X			L-5
VSDT	V-Steel Super Deep Traction		X			L-5
VSMS	V-Steel Smooth Tread-MS		X	X		L-5S
VSNL	V-Steel N-Lug		X			L-4
VSNT	V-Steel N-Traction		X			E-4/L-4
VSW	V-Steel Snow Wedge		X			G-2/L-2
VTS	V-Steel Traction-Stability		X			L-3
VUT	V-Steel Ultra Traction		X			G-2/L-2
VZTP	V-Steel Z-Traction Premium	X	X		X	E-4
VZTS	V-Steel Z-Traction S	X	X		X	E-4

The casing strength, i.e., load carrying capacity of tire is indicated by star rating system; 1-star, 2-star and 3-star. Bridgestone's Off-the-Road tires are designed and produced to meet the commonly accepted international standards, those set by the TRA (Tire and Rim Association) in the U.S.A., by the ETRTO (European Tire and Rim Technical Organization) in Europe and/or by the JATMA (Japan Automobile Tire Manufacturers' Association) in Japan. Where differences exist between the TRA, ETRTO and JATMA standards, Bridgestone selects the most appropriate.

Code Identification for Eurotire Radial and Bias Tires

Eurotire manufactures a range of bias-ply and radial tires for use on mining equipment. Eurotire steel radial tires are designated with an "EU." The following are the radial tread designs currently available from Eurotire with the compound and construction types for a variety of applications.

Compound Description	Compound Code			TRA Code(s)
	H	S	A	
Heat Resistant				H
Intermediate				S
Abrasion Resistant				A

Tread Design	Compound Code			TRA Code(s)
	H	S	A	
EUROK	X	X	X	E4
EUTRAK	—	X	X	E3, E4, L4

Eurotire radial tires are marked with a star rating system to indicate casing strength. Eurotire manufactures 2 star radial tires.

It is important to understand the specific usage and operating conditions of your job site so that the most appropriate tire choice can be determined. Eurotire representatives can help you make the most informed decision regarding tire choice, including weighing the benefits of radial vs. bias, selecting between different tread designs and compounds and providing service solutions to best suit your specific needs.

TON-KILOMETER PER HOUR (TKPH)

Tire selection and machine operating practices have, in some cases, become the critical factors in the over-all success of earthmoving ventures. One of the most serious problems occur when tires are operated at temperatures above their capabilities. Separation and related failures occur. To help you avoid temperature related failures, Caterpillar has been instrumental in developing the *Ton-Kilometer Per Hour* (TKPH), also known as *Ton-Mile Per Hour* (TMPH), method of rating tires. The formula to convert a TKPH rating to a TMPH rating is:

$$\text{TMPH} = \text{TKPH} \times 0.685$$

Heat and Tire Failure

Tire manufacturing requires heat in the vulcanizing process converting crude rubber and additives into a homogeneous compound. The heat required is typically above 132° C (270° F).

A tire also generates heat as it rolls and flexes. Heat generated faster than it can be radiated into the atmosphere gradually builds within the tire and reaches maximum level at the outermost ply or belt.

Over time, enough heat can develop from overflexing to actually reverse the vulcanizing process or “revert” the rubber causing ply separation and tire failure. Only a brief time at reversion temperature initiates the failure. Experience shows that few pure heat separation cases occur. Most so-called heat separations are in tires operating below the reversion level.

As a tire’s operating temperature increases the rubber and textiles within significantly lose strength. The tire becomes more susceptible to failures from cornering, braking, impact, cut through, fatigue and heat separation. If operating tires at higher temperatures is absolutely necessary, it is essential the machines be operated to reduce the probability of premature tire failure. No hard cornering without superelevation, no panic braking, etc.

The TKPH formula was developed to predict tire temperature buildup. The system is a method of rating tires in proportion to the amount of work they can do from a temperature standpoint. It utilizes the product of *load* × *speed* to derive an index of the tire temperature buildup. Even at or below a tire’s TKPH, failures may be initiated by overstressing the tires.

It is possible by using a needle type pyrometer to measure temperature at any desired point within the tire casing. However, the instrumentation and the technique does not lend itself to general field use. The greatest difficulty is locating the thickest (therefore the hottest) tread bar in any given tire using giant calipers. The tire must then be drilled along the centerline of this bar from shoulder to shoulder at 52 mm (2") intervals. These 3.18 mm (1/8") diameter holes extend down through the tread and undertread to the topmost reinforcement. This procedure is fully described under SAE Recommended practice J1015.

The TKPH rating system as given in this SAE specification is approved by most tire manufacturers. Michelin, in addition to providing TKPH ratings has developed their own speed/load carrying rating system and we recommend that Michelin be consulted where high tire temperatures are a concern.

Heat generation in a specific tire at recommended pressure depends on three factors:

- the weight the tire is carrying (flex per revolution),
- the speed the tire is traveling over the ground (flexures over a period of time), and
- the air temperature surrounding the tire (ambient temperature) and road surface temperature.

Once a tire manufacturer has determined a tire’s temperature characteristics and expressed them in TKPH, the above listed specific job conditions can be used to determine any tire’s maximum work capacity. These conditions provide on site ability to predict and avoid costly tire separations.

Ton-Kilometer-Per-Hour Rating System

The tire TKPH can be matched to the site TKPH as well as compared with TKPH values of different makes and types of tires.

TKPH Job Rate

Average Tire Load × Average Speed for the shift

Average Tire Load

$$\frac{\text{“Empty” tire load} + \text{“loaded” tire load}}{2}$$

Average Speed

$$\frac{\begin{array}{l} \text{Round trip distance in kilometers} \\ \times \text{ number of trips} \end{array}}{\text{Total Hours (in the shift)}}$$

For excessive haul length (32 kilometers or more) consult your tire representative for modification to the TKPH value.

To use in the United States Customary System, change kilometers to miles and use short tons.

It should be noted that prolonged operation at high casing temperatures can fatigue the nylon at the flex points in the sidewalls.

The following are the most recent TKPH ratings as made available by Goodyear, Michelin and Bridgestone, and are subject to change on their part at any time. Other tire manufacturers' TKPH ratings will be included in future handbook editions when and if made available. For latest TKPH ratings, consult specific tire manufacturer at time of machine and/or tire purchase.

Load-and-Carry TKPH

The wheel loader, when used in load-and-carry applications, may encounter temperature problems similar to those normally associated only with tires on scrapers, trucks and wagons. **Do not place the vehicle in load-and-carry applications without first consulting the tire manufacturer, or obtaining maximum load and speed ratings and pressure recommendations from the tire manufacturer.**

Conventional and Radial Steel Cord Tire Options

Tire options now provide types to operate in conditions ranging from rock and abrasive materials, to jobs with high speed hauls in good materials.

The best tire type can be different for the drive tires than for other tires on the same machine. TKPH should be calculated for all tires.

TIRE DRIVE-AWAY RECOMMENDATIONS

Heat separation can be a problem during machine delivery and moving machines from one job to another. Whenever roading earthmoving machines, *check your supplier for the tire manufacturer's recommended speed limitations on the specific tires involved.*

Some tire manufacturers also recommend that vehicles equipped with extra tread depth or special compounded tires should not be roaded without their specific approval. Our tests support this recommendation, especially for L-3, L-4, E-4 and L-5 tires.

TKPH RATINGS
AT 38° C (100° F) AMBIENT TEMPERATURE
For Haul Lengths of 32 km (20 miles) or Less One Way
Maximum Speed Not to Exceed 48 km (30 miles) per Hour

Because of the variance between specific tires it is recommended that at the time of purchase you check with your tire supplier for the manufacturer's specific TKPH ratings for the tires purchased.

GOODYEAR RADIAL PLY — CONVENTIONAL SIZES

Industry Code	E-3																				
	AT-2A			AT-3A			GP-2B			RL-3			RL-3+			RL-3A			RL-3J		
Tread Design	2S	4S	6S	2S	4S	6S	2S	4S	6S	2S	4S	6S	2S	4S	6S	2S	4S	6S	2S	4S	6S
Custom Code	TKPH																				
14.00R20	TKPH	—	—	—																	
16.00R20	TKPH	—	—	—	—	—	—														
16.00R21	TKPH	—	—	—																	
12.00R24	TKPH																				
13.00R24	TKPH																				
14.00R24	TKPH						—	—	—												
16.00R24	TKPH																				
14.00R25	TKPH						—	—	—												
16.00R25	TKPH						—	—	—				115	85	70						
18.00R25	TKPH												155	115	95						
18.00R33	TKPH												180	135	110						
21.00R33	TKPH																				
21.00R35	TKPH												245	185	145						
24.00R35	TKPH												300	230	180						
24.00R49	TKPH												375	280	—						
27.00R49	TKPH						450	375	—				375	310	185						
30.00R51	TKPH																				
33.00R51	TKPH																		620	480	290
36.00R51	TKPH									685	515	375	525	450	270						
37.00R57	TKPH																				
40.00R57	TKPH															785	600	355			
37.00R57	TKPH																				

TKPH RATINGS
AT 38° C (100° F) AMBIENT TEMPERATURE
For Haul Lengths of 32 km (20 miles) or Less One Way
Maximum Speed Not to Exceed 48 km (30 miles) per Hour

Because of the variance between specific tires it is recommended that at the time of purchase you check with your tire supplier for the manufacturer's specific TKPH ratings for the tires purchased.

GOODYEAR RADIAL PLY — CONVENTIONAL SIZES

Industry Code	E-4																				
	GP-4B			GP-4C			GT-4B			RL-4			RL-4A			RL-4B			RL-4C		
Tread Design	2S	4S	6S	2S	4S	6S	2S	4S	6S	2S	4S	6S	2S	4S	6S	2S	4S	6S	2S	4S	6S
Custom Code	2S	4S	6S	2S	4S	6S	2S	4S	6S	2S	4S	6S	2S	4S	6S	2S	4S	6S	2S	4S	6S
14.00R20 TKPH																					
16.00R20 TKPH																					
16.00R21 TKPH																					
12.00R24 TKPH																					
13.00R24 TKPH																					
14.00R24 TKPH																					
16.00R24 TKPH																					
14.00R25 TKPH																					
16.00R25 TKPH																					
18.00R25 TKPH										125	95	75				130	100	80			
18.00R33 TKPH				—	—	—				150	115	90				155	120	90			
21.00R33 TKPH																205	160	127			
21.00R35 TKPH																—	—	—			
24.00R35 TKPH							260	200	155							270	205	160			
24.00R49 TKPH										—	260	—				—	—	—			
27.00R49 TKPH	370	285	215				360	275	210	425	335	—	350	270	210	375	290	225			
30.00R51 TKPH																					
33.00R51 TKPH	490	370	260																470	360	250
36.00R51 TKPH																					
37.00R57 TKPH																			550	415	265
40.00R57 TKPH													785	600	355	865	660	390			
37.00R57 TKPH				615	460	295															

TKPH RATINGS
AT 38° C (100° F) AMBIENT TEMPERATURE
For Haul Lengths of 32 km (20 miles) or Less One Way
Maximum Speed Not to Exceed 48 km (30 miles) per Hour

Because of the variance between specific tires it is recommended that at the time of purchase you check with your tire supplier for the manufacturer's specific TKPH ratings for the tires purchased.

GOODYEAR RADIAL PLY – CONVENTIONAL SIZES

Industry Code	E-4																				
	RL-4F			RL-4H			RL-4HII			RL-4J			RL-4JII			RL-4K			RL-4L		
Tread Design	2S	4S	6S	2S	4S	6S	2S	4S	6S	2S	4S	6S	2S	4S	6S	2S	4S	6S	2S	4S	6S
Custom Code	2S	4S	6S	2S	4S	6S	2S	4S	6S	2S	4S	6S	2S	4S	6S	2S	4S	6S	2S	4S	6S
14.00R20 TKPH																					
16.00R20 TKPH																					
16.00R21 TKPH																					
12.00R24 TKPH										75	55	—									
13.00R24 TKPH																					
14.00R24 TKPH										85	65	—					—	—	—	—	—
16.00R24 TKPH																					
14.00R25 TKPH										85	65	—								—	—
16.00R25 TKPH																					
18.00R25 TKPH										130	100	—									
18.00R33 TKPH	140	105	85	155	120	90				155	120	90									
21.00R33 TKPH				215	165	130															
21.00R35 TKPH	200	150	120				215	165	130	215	165	130	215	165	130						
24.00R35 TKPH	245	185	145				270	205	160	270	205	160	270	205	160						
24.00R49 TKPH										320	245	190									
27.00R49 TKPH				345	265	200				375	300	180	375	300	180						
30.00R51 TKPH				450	340	205							410	310	185						
33.00R51 TKPH				470	360	250	470	360	250				520	395	270						
36.00R51 TKPH				565	490	300							515	445	270						
37.00R57 TKPH				655	490	315	550	410	245				620	480	290						
40.00R57 TKPH																					
37.00R57 TKPH																					

TKPH RATINGS
AT 38° C (100° F) AMBIENT TEMPERATURE
For Haul Lengths of 32 km (20 miles) or Less One Way
Maximum Speed Not to Exceed 48 km (30 miles) per Hour

Because of the variance between specific tires it is recommended that at the time of purchase you check with your tire supplier for the manufacturer's specific TKPH ratings for the tires purchased.

GOODYEAR RADIAL PLY – CONVENTIONAL SIZES

Industry Code	E-4												E-5		
	RL-4M+			RM-4A+			RT-4A			RT-4A+			RL-5K		
Tread Design	2S	4S	6S	2S	4S	6S	2S	4S	6S	2S	4S	6S	2S	4S	6S
Custom Code	2S	4S	6S	2S	4S	6S	2S	4S	6S	2S	4S	6S	2S	4S	6S
14.00R20 TKPH															
16.00R20 TKPH															
16.00R21 TKPH															
12.00R24 TKPH															
13.00R24 TKPH															
14.00R24 TKPH													–	–	–
16.00R24 TKPH															
14.00R25 TKPH															
16.00R25 TKPH															
18.00R25 TKPH															
18.00R33 TKPH							160	125	94						
21.00R33 TKPH															
21.00R35 TKPH															
24.00R35 TKPH										275	210	165			
24.00R49 TKPH															
27.00R49 TKPH				410	320	250				410	320	250			
30.00R51 TKPH															
33.00R51 TKPH	540	410	290	540	410	285									
36.00R51 TKPH															
37.00R57 TKPH	770	590	350	770	590	350									
40.00R57 TKPH															
37.00R57 TKPH															

TKPH RATINGS
AT 38° C (100° F) AMBIENT TEMPERATURE
For Haul Lengths of 32 km (20 miles) or Less One Way
Maximum Speed Not to Exceed 48 km (30 miles) per Hour

Because of the variance between specific tires it is recommended that at the time of purchase you check with your tire supplier for the manufacturer's specific TKPH ratings for the tires purchased.

GOODYEAR RADIAL PLY – WIDE BASE SIZES

Industry Code	E-3																				
	AT-2A			GP-2B			GP-3D			RL-2+			RL-3			RL-3F			RL-3J		
Tread Design	2S	4S	6S	2S	4S	6S	2S	4S	6S	2S	4S	6S	2S	4S	6S	2S	4S	6S	2S	4S	6S
Custom Code	2S	4S	6S	2S	4S	6S	2S	4S	6S	2S	4S	6S	2S	4S	6S	2S	4S	6S	2S	4S	6S
15.5R25 TKPH				—	—	—															
17.5R25 TKPH	130	75	65	135	105	95				100	75	—							85	—	—
20.5R25 TKPH				150	115	105				120	90	—									
23.5R25 TKPH				175	135	115	175	135	115	135	100	—									
26.5R25 TKPH				195	155	130				155	115	—									
29.5R25 TKPH				235	185	155				185	140	—									
29.5R29 TKPH										210	160	—	185	—	—						
33.25R29 TKPH																					
33.25R35 TKPH													—	210	—	—	210	—	—	230	—
37.25R35 TKPH																			—	260	—
37.5R39 TKPH													—	—	—				—	295	—

Industry Code	E-3									E-4														
	RT-3A			RT-3A+			TL-3A+			GP-4B			GP-4B AT			GP-4C			GP-4D			GT-4A		
Tread Design	2S	4S	6S	2S	4S	6S	2S	4S	6S	2S	4S	6S	2S	4S	6S	2S	4S	6S	2S	4S	6S	2S	4S	6S
Custom Code	2S	4S	6S	2S	4S	6S	2S	4S	6S	2S	4S	6S	2S	4S	6S	2S	4S	6S	2S	4S	6S	2S	4S	6S
15.5R25 TKPH																								
17.5R25 TKPH							100	75	—															
20.5R25 TKPH							120	90	—				—	—	—									
23.5R25 TKPH							135	100	—	—	—	—	135	104	90	—	—	—	—	—	—			
26.5R25 TKPH							155	115	—				147	109	91				—	—	—			
29.5R25 TKPH							185	145	125				165	130	105				170	135	115	—	—	—
29.5R29 TKPH																								
33.25R29 TKPH	285	220	—																					
33.25R35 TKPH																								
37.25R35 TKPH				—	—	—																		
37.5R39 TKPH																								

TKPH RATINGS
AT 38° C (100° F) AMBIENT TEMPERATURE
For Haul Lengths of 32 km (20 miles) or Less One Way
Maximum Speed Not to Exceed 48 km (30 miles) per Hour

Because of the variance between specific tires it is recommended that at the time of purchase you check with your tire supplier for the manufacturer's specific TKPH ratings for the tires purchased.

GOODYEAR RADIAL PLY — 95 SERIES SIZES

Industry Code	E-3					
	AS-3A			GP-2B		
Tread Design						
Custom Code	2S	4S	6S	2S	4S	6S
385/95R24 TKPH				—	—	—
385/95R25 TKPH	—	—	—	—	—	—
445/95R25 TKPH				—	—	—

TKPH RATINGS
AT 38° C (100° F) AMBIENT TEMPERATURE
For Haul Lengths of 32 km (20 miles) or Less One Way
Maximum Speed Not to Exceed 48 km (30 miles) per Hour

Because of the variance between specific tires it is recommended that at the time of purchase you check with your tire supplier for the manufacturer's specific TKPH ratings for the tires purchased.

GOODYEAR RADIAL PLY — 90 SERIES SIZES

Industry Code	E-4					
	RL-4B			RM-4A+		
Tread Design						
Custom Code	2S	4S	6S	2S	4S	6S
46/90R57 TKPH	910	690	410	980	750	440

TKPH RATINGS
AT 38° C (100° F) AMBIENT TEMPERATURE
For Haul Lengths of 32 km (20 miles) or Less One Way
Maximum Speed Not to Exceed 48 km (30 miles) per Hour

Because of the variance between specific tires it is recommended that at the time of purchase you check with your tire supplier for the manufacturer's specific TKPH ratings for the tires purchased.

GOODYEAR RADIAL PLY – 80 SERIES SIZES

Industry Code	E-1			E-2			E-3						E-4		
	HRR-1A			SP-T9			GP-2B			RM-3A			RM-4A+		
Custom Code	2S	4S	6S	2S	4S	6S	2S	4S	6S	2S	4S	6S	2S	4S	6S
335/80R18 TKPH	–	–	–	–	–	–									
395/80R25 TKPH							–	–	–						
445/80R25 TKPH							–	–	–						
525/80R25 TKPH							–	–	–						
605/80R25 TKPH							–	–	–						
53/80R63 TKPH										1200	–	–	1070	–	–
59/80R63 TKPH										1500	–	–	1300	–	–

TKPH RATINGS
AT 38° C (100° F) AMBIENT TEMPERATURE
For Haul Lengths of 32 km (20 miles) or Less One Way
Maximum Speed Not to Exceed 48 km (30 miles) per Hour

Because of the variance between specific tires it is recommended that at the time of purchase you check with your tire supplier for the manufacturer's specific TKPH ratings for the tires purchased.

GOODYEAR RADIAL PLY – 75 SERIES SIZES

Industry Code	E-3					
	GP-2B			RT-3A+		
Custom Code	2S	4S	6S	2S	4S	6S
40.5/75R39 TKPH	400	305	240	375	290	220

TKPH RATINGS
AT 38° C (100° F) AMBIENT TEMPERATURE
For Haul Lengths of 32 km (20 miles) or Less One Way
Maximum Speed Not to Exceed 48 km (30 miles) per Hour

Because of the variance between specific tires it is recommended that at the time of purchase you check with your tire supplier for the manufacturer's specific TKPH ratings for the tires purchased.

GOODYEAR RADIAL PLY — 65 SERIES SIZES

Industry Code	E-3															E-4		
	AT-2A			GP-3D			RL-2+			RL-3F			TL-3A+			GP-4D		
Tread Design	2S	4S	6S	2S	4S	6S	2S	4S	6S	2S	4S	6S	2S	4S	6S	2S	4S	6S
Custom Code	2S	4S	6S	2S	4S	6S	2S	4S	6S	2S	4S	6S	2S	4S	6S	2S	4S	6S
555/65R25 TKPH	195	—	—															
600/65R25 TKPH				132	99	66												
650/65R25 TKPH				144	108	73				—	125	—						
750/65R25 TKPH				162	120	78	155	115	75				—	—	—			
775/65R29 TKPH																169	125	105
800/65R29 TKPH																169	125	105
875/65R29 TKPH																185	150	121

TKPH RATINGS
AT 38° C (100° F) AMBIENT TEMPERATURE
For Haul Lengths of 32 km (20 miles) or Less One Way
Maximum Speed Not to Exceed 48 km (30 miles) per Hour

Because of the variance between specific tires it is recommended that at the time of purchase you check with your tire supplier for the manufacturer's specific TKPH ratings for the tires purchased.

GOODYEAR BIAS PLY – CONVENTIONAL SIZES

Industry Code	E-1			E-3								
	HRR-1A			GP-2B			HRL-3A			WRL-3A		
Tread Design	HRR-1A			GP-2B			HRL-3A			WRL-3A		
Custom Code	2S	4S	6S	2S	4S	6S	2S	4S	6S	2S	4S	6S
9.00-15 TKPH												
9.00-16 TKPH												
16.00-16 TKPH												
12.00-20 TKPH							—	—	—			
14.00-20 TKPH							—	—	—	—	—	—
16.00-20 TKPH												
12.00-24 TKPH							—	—	—			
14.00-24 TKPH							—	—	—	—	—	—
16.00-24 TKPH							—	—	—			
14.00-25 TKPH							—	50	—			
16.00-25 TKPH	125	90	—	—	—	—	—	70	—			
18.00-25 TKPH	145	100	—				125	90	—			
21.00-25 TKPH							—	—	—			
18.00-33 TKPH							150	110	—			
21.00-35 TKPH							200	145	—			
24.00-35 TKPH							—	175	—			
21.00-49 TKPH												
24.00-49 TKPH												
27.00-49 TKPH												
30.00-51 TKPH												
33.00-51 TKPH												
36.00-51 TKPH												

TKPH RATINGS
AT 38° C (100° F) AMBIENT TEMPERATURE
For Haul Lengths of 32 km (20 miles) or Less One Way
Maximum Speed Not to Exceed 48 km (30 miles) per Hour

Because of the variance between specific tires it is recommended that at the time of purchase you check with your tire supplier for the manufacturer's specific TKPH ratings for the tires purchased.

GOODYEAR BIAS PLY — CONVENTIONAL SIZES

Industry Code	E-4												E-7					
	HRL-4B			HRL-4D			MRL-4B			MRL-4D			PVG-7A			SRB-7A		
Tread Design	2S	4S	6S	2S	4S	6S	2S	4S	6S	2S	4S	6S	2S	4S	6S	2S	4S	6S
Custom Code	2S	4S	6S	2S	4S	6S	2S	4S	6S	2S	4S	6S	2S	4S	6S	2S	4S	6S
9.00-15 TKPH																—	—	—
9.00-16 TKPH																—	—	—
16.00-16 TKPH																—	—	—
12.00-20 TKPH																		
14.00-20 TKPH																—	—	—
16.00-20 TKPH																—	—	—
12.00-24 TKPH																		
14.00-24 TKPH																		
16.00-24 TKPH													—	—	—			
14.00-25 TKPH																		
16.00-25 TKPH	90	65	—															
18.00-25 TKPH	—	80	—				74	—	—							—	160	—
21.00-25 TKPH	—															—	185	—
18.00-33 TKPH	—	100	85															
21.00-35 TKPH	180	130	110				—	115	—									
24.00-35 TKPH	—	160	—				—	140	—									
21.00-49 TKPH	—	160	—															
24.00-49 TKPH	—	190	165				—	165	—	234	175	—						
27.00-49 TKPH	310	235	175							—	190	—						
30.00-51 TKPH	—	265	—				—	245	—									
33.00-51 TKPH	395	300	—															
36.00-51 TKPH	465	335	—	450	—	—	—	325	—									

**TKPH RATINGS
AT 38° C (100° F) AMBIENT TEMPERATURE
For Haul Lengths of 32 km (20 miles) or Less One Way
Maximum Speed Not to Exceed 48 km (30 miles) per Hour**

Because of the variance between specific tires it is recommended that at the time of purchase you check with your tire supplier for the manufacturer's specific TKPH ratings for the tires purchased.

GOODYEAR BIAS PLY – WIDE BASE SIZES

Industry Code	Tread Design	E-2			E-3														
		SGL E/L-2A			HRL E/L-3A			HRL-3A			HRL-3F			SHRL			SHRL8		
Custom Code		2S	4S	6S	2S	4S	6S	2S	4S	6S	2S	4S	6S	2S	4S	6S	2S	4S	6S
20.5-25	TKPH	–	–	–	–	–	–	–	65	–									
23.5-25	TKPH	–	–	–	–	–	–	–	70	–									
26.5-25	TKPH													–	90	–			
29.5-25	TKPH							–	115	–				–	115	–			
26.5-29	TKPH													–	110	–			
29.5-29	TKPH							175	125	–				175	125	–			
33.5-33	TKPH										–	160	–	–	–	–	–	170	–
37.5-33	TKPH										–	210	–				–	220	–
33.25-35	TKPH										–	160	–				–	–	–
37.25-35	TKPH										–	210	–				–	220	–
29.5-35	TKPH													–	145	–	–	160	–
37.5-39	TKPH										–	225	–				–	240	–

**TKPH RATINGS
AT 38° C (100° F) AMBIENT TEMPERATURE
For Haul Lengths of 32 km (20 miles) or Less One Way
Maximum Speed Not to Exceed 48 km (30 miles) per Hour**

Because of the variance between specific tires it is recommended that at the time of purchase you check with your tire supplier for the manufacturer's specific TKPH ratings for the tires purchased.

GOODYEAR BIAS PLY – 65 SERIES SIZES

Industry Code	Tread Design	E-4					
		NRL D/L-4A					
Custom Code		2S		4S		6S	
35/65-33	TKPH	115		95		75	

TKPH RATINGS
AT 38° C (100° F) AMBIENT TEMPERATURE
For Haul Lengths of 32 km (20 miles) or Less One Way
Maximum Speed Not to Exceed 48 km (30 miles) per Hour

Because of the variance between specific tires it is recommended that at the time of purchase you check with your tire supplier for the manufacturer's specific TKPH ratings for the tires purchased.

BRIDGESTONE RADIAL PLY — CONVENTIONAL SIZES

Industry Code	E-2									E-3								
	VFT			VHS			VKT			VSB	VEL			VMT			VRL	
Tread Design	3A	1A	2A	3A	1A	3A	1A	2A	2A	3A	1A	2A	3A	1A	2A	3A	1A	2A
Custom Code	3A	1A	2A	3A	1A	3A	1A	2A	2A	3A	1A	2A	3A	1A	2A	3A	1A	2A
11.00R20 TKPH																		
12.00R20 TKPH																		
16.00R20 TKPH																		
12R22.5 TKPH																		
12.00R24 TKPH																		
13.00R24 TKPH																		
14.00R24 TKPH									—	—								
16.00R24 TKPH																		
14.00R25 TKPH									—									
16.00R25 TKPH																		
18.00R25 TKPH		183						183		—	—	—						
21.00R25 TKPH																		
18.00R33 TKPH	328	281	227			328	281	227		307	263	213				307	263	213
21.00R33 TKPH																		
21.00R35 TKPH											351	284					351	284
24.00R35 TKPH										524	448					524	448	
24.00R49 TKPH		562	455				445	562										
27.00R49 TKPH	804	688	557			804	688	557		753	644	521				753	644	521
30.00R51 TKPH				1171	1001								1065	897				
33.00R51 TKPH													1209	1018	837			
36.00R51 TKPH				—									1407	1185	974			
37.00R57 TKPH																		
40.00R57 TKPH													1739	1463	1204			

NOTE: For cycle lengths of 5 km (3 miles) or less (round trip), multiply the TKPH value in this table by 1.12.
Additional tread compounds are available to meet specific TKPH.

TKPH RATINGS
AT 38° C (100° F) AMBIENT TEMPERATURE
For Haul Lengths of 32 km (20 miles) or Less One Way
Maximum Speed Not to Exceed 48 km (30 miles) per Hour

Because of the variance between specific tires it is recommended that at the time of purchase you check with your tire supplier for the manufacturer's specific TKPH ratings for the tires purchased.

BRIDGESTONE RADIAL PLY – CONVENTIONAL SIZES

Industry Code	E-4														
	L317	VELS			VELSL		VMTP			VMTS			VRDP		
Tread Design		3A	1A	2A	3A	1A	3A	1A	2A	3A	1A	2A	3A	1A	2A
Custom Code	–														
11.00R20 TKPH	188														
12.00R20 TKPH	208														
16.00R20 TKPH															
12R22.5 TKPH	188														
12.00R24 TKPH	177								136						
13.00R24 TKPH															
14.00R24 TKPH				85						136	119	91			
16.00R24 TKPH															
14.00R25 TKPH				85						136	119	91			
16.00R25 TKPH			146	112								123			
18.00R25 TKPH			179	144						244	209	169			
21.00R25 TKPH															
18.00R33 TKPH		246	211	170			267	229	185	287	246	199			
21.00R33 TKPH			281	227			–	–	–						
21.00R35 TKPH		328	281	227				293	237	383	328	265			
24.00R35 TKPH		453	388	314				388	314	489	418	338			
24.00R49 TKPH		492	421	341			552		361	575	492	398			
27.00R49 TKPH		600	513	415			636	544	440	702	600	486	600	513	415
30.00R51 TKPH		717	603	496											
33.00R51 TKPH		807	679	558			855	700	591				807	679	558
36.00R51 TKPH		927	781	642											
37.00R57 TKPH		1003	845	694	1148										
40.00R57 TKPH		1117	940	773	1330	1050							1117	940	773

NOTE: For cycle lengths of 5 km (3 miles) or less (round trip), multiply the TKPH value in this table by 1.12.
Additional tread compounds are available to meet specific TKPH.

TKPH RATINGS
AT 38° C (100° F) AMBIENT TEMPERATURE
For Haul Lengths of 32 km (20 miles) or Less One Way
Maximum Speed Not to Exceed 48 km (30 miles) per Hour

Because of the variance between specific tires it is recommended that at the time of purchase you check with your tire supplier for the manufacturer's specific TKPH ratings for the tires purchased.

BRIDGESTONE RADIAL PLY — CONVENTIONAL SIZES

Industry Code	E-4											E-7
	Tread Design	VREP	VRLS			VRPS			VRQP	VZTS		
Custom Code	—	3A	1A	2A	3A	1A	2A	2ALS	3A	1A	2A	—
11.00R20	TKPH											
12.00R20	TKPH											
16.00R20	TKPH											—
12R22.5	TKPH											
12.00R24	TKPH											
13.00R24	TKPH											
14.00R24	TKPH				85							
16.00R24	TKPH											
14.00R25	TKPH				85							
16.00R25	TKPH			146	112							
18.00R25	TKPH											
21.00R25	TKPH											—
18.00R33	TKPH		246	211	170			122				
21.00R33	TKPH			281	227							
21.00R35	TKPH		328	281	227							
24.00R35	TKPH		453	388	314			207				
24.00R49	TKPH		492	421	341							
27.00R49	TKPH	—	600	513	415							
30.00R51	TKPH		717	603	496							
33.00R51	TKPH		807	679	558							
36.00R51	TKPH		927	781	642							
37.00R57	TKPH		1003	845	694				1003	845	694	
40.00R57	TKPH		1117	940	773	—	—	—		1117	940	773

NOTE: For cycle lengths of 5 km (3 miles) or less (round trip), multiply the TKPH value in this table by 1.12.
Additional tread compounds are available to meet specific TKPH.

TKPH RATINGS
AT 38° C (100° F) AMBIENT TEMPERATURE
For Haul Lengths of 32 km (20 miles) or Less One Way
Maximum Speed Not to Exceed 48 km (30 miles) per Hour

Because of the variance between specific tires it is recommended that at the time of purchase you check with your tire supplier for the manufacturer's specific TKPH ratings for the tires purchased.

BRIDGESTONE RADIAL PLY — WIDE BASE SIZES

Industry Code	E-2			E-3								E-4	
	TKT			VJT		VLT		VMT		VRL		VLTS	VSNT
Custom Code	3A	1A	2A	1A	2A	1A	2A	1A	2A	1A	2A	2A	2A
15.5R25 TKPH													
17.5R25 TKPH			95					—					
20.5R25 TKPH		166	129	—			—					—	
23.5R25 TKPH		263	205	248	190		190	248	190			161	
26.5R25 TKPH		312	257	293	220		220	293	220			186	165
29.5R25 TKPH	420	376	310	354	266		266	354	266			225	220
29.5R29 TKPH		401	330										232
33.25R29 TKPH		494	407			476	349			435	319		
37.5R33 TKPH		648											
29.5R35 TKPH										380			
33.25R35 TKPH			441							472	346		
37.25R35 TKPH	720	644	530			569	417			563	413		
37.5R39 TKPH		696								608			

NOTE: For cycle lengths of 5 km (3 miles) or less (round trip), multiply the TKPH value in this table by 1.12.
 Additional tread compounds are available to meet specific TKPH.

TKPH RATINGS
AT 38° C (100° F) AMBIENT TEMPERATURE
For Haul Lengths of 32 km (20 miles) or Less One Way
Maximum Speed Not to Exceed 48 km (30 miles) per Hour

Because of the variance between specific tires it is recommended that at the time of purchase you check with your tire supplier for the manufacturer's specific TKPH ratings for the tires purchased.

BRIDGESTONE RADIAL PLY — 95 SERIES SIZES

Industry Code	E-2						E-3	
	VFT		VKT		VS	VEL		
Custom Code	1A	2A	1A	2A	2A	1A	2A	
385/95R24 TKPH	141	106	141	106	179			
385/95R25 TKPH								
505/95R25 TKPH	239	193	239	193		224	181	

NOTE: For cycle lengths of 5 km (3 miles) or less (round trip), multiply the TKPH value in this table by 1.12.
Additional tread compounds are available to meet specific TKPH.

TKPH RATINGS
AT 38° C (100° F) AMBIENT TEMPERATURE
For Haul Lengths of 32 km (20 miles) or Less One Way
Maximum Speed Not to Exceed 48 km (30 miles) per Hour

Because of the variance between specific tires it is recommended that at the time of purchase you check with your tire supplier for the manufacturer's specific TKPH ratings for the tires purchased.

BRIDGESTONE RADIAL PLY — 90 SERIES SIZES

Industry Code	E-4												
	VELS			VRDP			VRLS			VRPS			VZTP
Custom Code	3A	1A	2A	3A	1A	2A	3A	1A	2A	3A	1A	2A	2ALS
21/90R33 TKPH	246	211	170				246	211	170				
31/90R49 TKPH	618	528	427				618	528	427				
42/90R57 TKPH				1033	870	715							
46/90R57 TKPH	1150	968	796	1150	968	796	1150	968	796	—	—	—	585
50/90R57 TKPH	1278	1092	884				1278	1092	884	—	—	—	

NOTE: For cycle lengths of 5 km (3 miles) or less (round trip), multiply the TKPH value in this table by 1.12.
Additional tread compounds are available to meet specific TKPH.

TKPH RATINGS
AT 38° C (100° F) AMBIENT TEMPERATURE
For Haul Lengths of 32 km (20 miles) or Less One Way
Maximum Speed Not to Exceed 48 km (30 miles) per Hour

Because of the variance between specific tires it is recommended that at the time of purchase you check with your tire supplier for the manufacturer's specific TKPH ratings for the tires purchased.

BRIDGESTONE RADIAL PLY — 80 SERIES SIZES

Industry Code	E-2			E-3								
	TKPH			VJT		VLT	VMT		VRD		VRF	
Tread Design	VKT			VJT		VLT	VMT		VRD		VRF	
Custom Code	3A	1A	2A	1A	2A	2A	1A	2A	3A	1A	3A	1A
335/80R20 TKPH												
365/80R20 TKPH												
445/80R25 TKPH				144			144					
525/80R25 TKPH	232	206	160	194	149	149	194	149				
53/80R63 TKPH											—	—
55/80R63 TKPH												
59/80R63 TKPH									—	—	—	—

NOTE: For cycle lengths of 5 km (3 miles) or less (round trip), multiply the TKPH value in this table by 1.12.
Additional tread compounds are available to meet specific TKPH.

BRIDGESTONE RADIAL PLY — 80 SERIES SIZES

Industry Code	E-4									
	TKPH	VRDP			VRLS			VRPS		
Tread Design	VLTS	VRDP			VRLS			VRPS		
Custom Code	2A	3A	1A	2A	3A	1A	2A	3A	1A	2A
335/80R20 TKPH										
365/80R20 TKPH										
445/80R25 TKPH										
525/80R25 TKPH	126									
53/80R63 TKPH		1408	1150	974	1512	1233	1045	—	—	—
55/80R63 TKPH		1643	1341	1137						
59/80R63 TKPH		*	*	*					—	—

*Consult Bridgestone Representative.
NOTE: For cycle lengths of 5 km (3 miles) or less (round trip), multiply the TKPH value in this table by 1.12.
Additional tread compounds are available to meet specific TKPH.

TKPH RATINGS
AT 38° C (100° F) AMBIENT TEMPERATURE
For Haul Lengths of 32 km (20 miles) or Less One Way
Maximum Speed Not to Exceed 48 km (30 miles) per Hour

Because of the variance between specific tires it is recommended that at the time of purchase you check with your tire supplier for the manufacturer's specific TKPH ratings for the tires purchased.

BRIDGESTONE RADIAL PLY — 75 SERIES SIZES

Industry Code	E-3				
	VLT			VRL	
Tread Design	1A	2A	3A	1A	2A
40.5/75R39 TKPH	682	500	765	675	495

NOTE: For cycle lengths of 5 km (3 miles) or less (round trip), multiply the TKPH value in this table by 1.12.
Additional tread compounds are available to meet specific TKPH.

TKPH RATINGS
AT 38° C (100° F) AMBIENT TEMPERATURE
For Haul Lengths of 32 km (20 miles) or Less One Way
Maximum Speed Not to Exceed 48 km (30 miles) per Hour

Because of the variance between specific tires it is recommended that at the time of purchase you check with your tire supplier for the manufacturer's specific TKPH ratings for the tires purchased.

BRIDGESTONE RADIAL PLY — 65 SERIES SIZES

Industry Code	E-2	E-3		E-4	
	VKT	VLT	VTS	VLTS	VSNT
Custom Code	2A	2A	—	2A	2A
25/65R25 TKPH	162				
30/65R25 TKPH		225		195	
550/65R25 TKPH			—		
600/65R25 TKPH					
650/65R25 TKPH			—		
750/65R25 TKPH		—	—	195	
775/65R29 TKPH			—		
875/65R29 TKPH			—		
35/65R33 TKPH					250

NOTE: For cycle lengths of 5 km (3 miles) or less (round trip), multiply the TKPH value in this table by 1.12.
Additional tread compounds are available to meet specific TKPH.

TKPH RATINGS
AT 38° C (100° F) AMBIENT TEMPERATURE
For Haul Lengths of 32 km (20 miles) or Less One Way
Maximum Speed Not to Exceed 48 km (30 miles) per Hour

Because of the variance between specific tires it is recommended that at the time of purchase you check with your tire supplier for the manufacturer's specific TKPH ratings for the tires purchased.

BRIDGESTONE BIAS PLY – CONVENTIONAL SIZES

Industry Code	E-3			E-4		E-7
	RL		WL	ELS2	RLS	SCP2
Custom Code	1A	2A	—	IDU	2A	—
9.00-20 TKPH			—			
10.00-20 TKPH	—	—				
11.00-20 TKPH	—	—				
12.00-20 TKPH	—	—				
14.00-20 TKPH						—
12.00-24 TKPH	—	—				
14.00-24 TKPH	—	—			—	
16.00-25 TKPH	—	—			—	
18.00-25 TKPH	—	—		—	—	
18.00-33 TKPH				—	—	
21.00-35 TKPH				—		

NOTE: For cycle lengths of 5 km (3 miles) or less (round trip), multiply the TKPH value in this table by 1.12.
Additional tread compounds are available to meet specific TKPH.

BRIDGESTONE BIAS PLY – CONVENTIONAL SIZES

Industry Code	E-3			E-4
	RL		VL2	RLS
Custom Code	1A	2A	—	2A
20.5-25 TKPH			—	
23.5-25 TKPH			—	—
26.5-25 TKPH			—	—
29.5-25 TKPH			—	—
37.25-35 TKPH	—	—		

NOTE: For cycle lengths of 5 km (3 miles) or less (round trip), multiply the TKPH value in this table by 1.12.
Additional tread compounds are available to meet specific TKPH.

TKPH RATINGS
AT 38° C (100° F) AMBIENT TEMPERATURE
For Haul Cycles Less than 5 km (3 miles) Round Trip

Because of the variance between specific tires it is recommended that at the time of purchase you check with your tire supplier for the manufacturer's specific TKPH ratings for the tires purchased.

MICHELIN RADIAL PLY – CONVENTIONAL SIZES

Industry Code	E-2						E-3						
	XHM	XL	XMH	XSNO+	XV	XZL	XDC			XDM		XK	
Tread Design							C4	B	B4	C	C4	B	A
Custom Code	–	B	–	–	C	–							
16.00R20 TKPH						–							
24R20.5 TKPH													
24R21 TKPH						–							
12.00R24 TKPH													
14.00R24 TKPH	–			–									–
14.00R25 TKPH			232										
16.00R25 TKPH		–										187	
18.00R25 TKPH					284							237	
21.00R25 TKPH													
18.00R33 TKPH					436								
21.00R33 TKPH													
21.00R35 TKPH													
24.00R35 TKPH					740								
24.00R49 TKPH													
27.00R49 TKPH					1090								
30.00R51 TKPH													
33.00R51 TKPH							1395	1209	1054				
36.00R51 TKPH							1480	1369	1258				
37.00R57 TKPH													
40.00R57 TKPH							1920	1776	1632	1584	1440		

NOTE: Consult Michelin for TKPH rating on haul cycles greater than 5 km (3 miles).
Additional tread compounds are available to meet specific TKPH.

**TKPH RATINGS
AT 38° C (100° F) AMBIENT TEMPERATURE
For Haul Cycles Less than 5 km (3 miles) Round Trip**

Because of the variance between specific tires it is recommended that at the time of purchase you check with your tire supplier for the manufacturer's specific TKPH ratings for the tires purchased.

MICHELIN RADIAL PLY – CONVENTIONAL SIZES

Industry Code	E-3			E-4						
	XR B	XZH	X-TRACTION S	XDM		XDR				
Custom Code	B	—	B	B	B4	C	C4	B	B4	A
16.00R20	TKPH									
24R20.5	TKPH									
24R21	TKPH									
12.00R24	TKPH	119								
14.00R24	TKPH									
14.00R25	TKPH									
16.00R25	TKPH									
18.00R25	TKPH									
21.00R25	TKPH									
18.00R33	TKPH	305								
21.00R33	TKPH									
21.00R35	TKPH									
24.00R35	TKPH									
24.00R49	TKPH							453	384	
27.00R49	TKPH		763					567	480	392
30.00R51	TKPH							643	536	
33.00R51	TKPH						837	744	620	496
36.00R51	TKPH							888	740	
37.00R57	TKPH				1018	848	1272	1145	1018	848
40.00R57	TKPH						1440	1296	1152	960

NOTE: Consult Michelin for TKPH rating on haul cycles greater than 5 km (3 miles).
Additional tread compounds are available to meet specific TKPH.

TKPH RATINGS
AT 38° C (100° F) AMBIENT TEMPERATURE
For Haul Cycles Less than 5 km (3 miles) Round Trip

Because of the variance between specific tires it is recommended that at the time of purchase you check with your tire supplier for the manufacturer's specific TKPH ratings for the tires purchased.

MICHELIN RADIAL PLY – CONVENTIONAL SIZES

Industry Code	E-4														
	XDR+				XDR2					XDT			XH D1		
Tread Design															
Custom Code	C	C4	B	B4	C	C4	B	B4	A	B	A	A4	B	A	A4
16.00R20 TKPH															
24R20.5 TKPH															
24R21 TKPH															
12.00R24 TKPH															
14.00R24 TKPH															
14.00R25 TKPH														102	84
16.00R25 TKPH														164	
18.00R25 TKPH													222	163	133
21.00R25 TKPH															
18.00R33 TKPH										262		157			
21.00R33 TKPH															
21.00R35 TKPH										348		209			
24.00R35 TKPH										444	326	226			
24.00R49 TKPH															
27.00R49 TKPH							567	480	392	654	480	392			
30.00R51 TKPH															
33.00R51 TKPH						837	744	620		930	682				
36.00R51 TKPH															
37.00R57 TKPH					1272	1145	1018	848							
40.00R57 TKPH	1440	1296	1152	960	1440	1296	1152	960							

NOTE: Consult Michelin for TKPH rating on haul cycles greater than 5 km (3 miles).
Additional tread compounds are available to meet specific TKPH.

**TKPH RATINGS
AT 38° C (100° F) AMBIENT TEMPERATURE
For Haul Cycles Less than 5 km (3 miles) Round Trip**

Because of the variance between specific tires it is recommended that at the time of purchase you check with your tire supplier for the manufacturer's specific TKPH ratings for the tires purchased.

MICHELIN RADIAL PLY – CONVENTIONAL SIZES

Industry Code	E-4										E-7
	XK D1	X-HAUL	X-HAUL S	X-QUARRY	X-QUARRY S	X-TRACTION			X-TRACTION S		
Custom Code	A	—	—	—	—	B	B4	A4	C	B	—
16.00R20 TKPH											
24R20.5 TKPH											—
24R21 TKPH											
12.00R24 TKPH											
14.00R24 TKPH	84										
14.00R25 TKPH											
16.00R25 TKPH				93							
18.00R25 TKPH	133										—
21.00R25 TKPH											—
18.00R33 TKPH		262			166		218				
21.00R33 TKPH			280				280				
21.00R35 TKPH	209			122							
24.00R35 TKPH	385	355		207	281		370		281		
24.00R49 TKPH											
27.00R49 TKPH						654	567	392		763	
30.00R51 TKPH											
33.00R51 TKPH											
36.00R51 TKPH											
37.00R57 TKPH											
40.00R57 TKPH											

NOTE: Consult Michelin for TKPH rating on haul cycles greater than 5 km (3 miles).
Additional tread compounds are available to meet specific TKPH.

TKPH RATINGS
AT 38° C (100° F) AMBIENT TEMPERATURE
For Haul Cycles Less than 5 km (3 miles) Round Trip

Because of the variance between specific tires it is recommended that at the time of purchase you check with your tire supplier for the manufacturer's specific TKPH ratings for the tires purchased.

MICHELIN RADIAL PLY – WIDE BASE SIZES

Industry Code	E-2			E-3		E-4			E-7
Tread Design	XG	XL	XSNO+	XADN	XTS	XADT	XRS	X-SUPER TERRAIN	XS
Custom Code	C	B	—	—	—	—	B	—	—
17.5R25 TKPH	—		—						
20.5R25 TKPH			—			—			
23.5R25 TKPH		—	—					—	
26.5R25 TKPH		—						—	
29.5R25 TKPH				—				—	—
29.5R29 TKPH					348				
33.25R29 TKPH					429				
29.5R35 TKPH					371				
37.25R35 TKPH					540		415		
37.5R39 TKPH							453		

NOTE: Consult Michelin for TKPH rating on haul cycles greater than 5 km (3 miles).
Additional tread compounds are available to meet specific TKPH.

TKPH RATINGS
AT 38° C (100° F) AMBIENT TEMPERATURE
For Haul Cycles Less than 5 km (3 miles) Round Trip

Because of the variance between specific tires it is recommended that at the time of purchase you check with your tire supplier for the manufacturer's specific TKPH ratings for the tires purchased.

MICHELIN RADIAL PLY – 95 SERIES SIZES

Industry Code	E-2			
Tread Design	XL	S	XSNO+	XV
Custom Code	B	—	—	C
385/95R24 TKPH		—	—	
385/95R25 TKPH		—	—	
445/95R25 TKPH	—			
505/95R25 TKPH				284

NOTE: Consult Michelin for TKPH rating on haul cycles greater than 5 km (3 miles).
Additional tread compounds are available to meet specific TKPH.

TKPH RATINGS
AT 38° C (100° F) AMBIENT TEMPERATURE
For Haul Cycles Less than 5 km (3 miles) Round Trip

Because of the variance between specific tires it is recommended that at the time of purchase you check with your tire supplier for the manufacturer's specific TKPH ratings for the tires purchased.

MICHELIN RADIAL PLY – 90 SERIES SIZES

Industry Code	E-4		
Tread Design	XDR		
Custom Code	C4	B	B4
50/90R57 TKPH	1747	1498	1248

NOTE: Consult Michelin for TKPH rating on haul cycles greater than 5 km (3 miles).
Additional tread compounds are available to meet specific TKPH.

TKPH RATINGS
AT 38° C (100° F) AMBIENT TEMPERATURE
For Haul Cycles Less than 5 km (3 miles) Round Trip

Because of the variance between specific tires it is recommended that at the time of purchase you check with your tire supplier for the manufacturer's specific TKPH ratings for the tires purchased.

MICHELIN RADIAL PLY – 80 SERIES SIZES

Industry Code	E-2	E-3			E-4							
	XL	XDR S		XMP	XDR				XDR2			
Custom Code	B	C4	B	—	C4	B	B4	A	C4	B	B4	A
395/80R25 TKPH				180								
525/80R25 TKPH	—											
50/80R57 TKPH					1394	1286	1072					
53/80R63 TKPH					1837	1574	1312		1837	1574	1312	
56/80R63 TKPH		2765	2458		2150	1843	1536					
59/80R63 TKPH		2535	2218		2218	1901	1584	1267	2218	1901	1584	1267

NOTE: Consult Michelin for TKPH rating on haul cycles greater than 5 km (3 miles).
Additional tread compounds are available to meet specific TKPH.

TKPH RATINGS
AT 38° C (100° F) AMBIENT TEMPERATURE
For Haul Cycles Less than 5 km (3 miles) Round Trip

Because of the variance between specific tires it is recommended that at the time of purchase you check with your tire supplier for the manufacturer's specific TKPH ratings for the tires purchased.

MICHELIN RADIAL PLY – 75 SERIES SIZES

Industry Code	E-3	
	XMS	
Custom Code	B	A
40.5/75R39 TKPH	766	500

NOTE: Consult Michelin for TKPH rating on haul cycles greater than 5 km (3 miles).
Additional tread compounds are available to meet specific TKPH.

TKPH RATINGS
AT 38° C (100° F) AMBIENT TEMPERATURE
For Haul Cycles Less than 5 km (3 miles) Round Trip

Because of the variance between specific tires it is recommended that at the time of purchase you check with your tire supplier for the manufacturer's specific TKPH ratings for the tires purchased.

MICHELIN RADIAL PLY – 65 SERIES SIZES

Industry Code	E-3	E-4	E-7
Tread Design	XAD 65	XTXL	XS
Custom Code	—	—	—
525/65R20.5 TKPH			—
650/65R25 TKPH	—		
750/65R25 TKPH	—		
850/65R25 TKPH	—		
775/65R29 TKPH	—		
875/65R29 TKPH	—		
35/65R33 TKPH		250	

NOTE: Consult Michelin for TKPH rating on haul cycles greater than 5 km (3 miles).
 Additional tread compounds are available to meet specific TKPH.

**ISO LOAD INDEX SPEED SYMBOL
AT 38° C (100° F) AMBIENT TEMPERATURE
For Haul Cycles Greater than 5 km (3 miles) Round Trip**

Because of the variance between specific tires it is recommended that at the time of purchase you check with your tire supplier for the manufacturer's specific TKPH ratings for the tires purchased.

MICHELIN RADIAL PLY — CONVENTIONAL SIZES

Industry Code	E-2			E-7
Tread Design	XL	XV	XZL	XS
Custom Code	B	C	—	—
16.00R20			173G	
24R20.5				176F
24R21			176G	
16.00R25	177E			
18.00R25		186E		—

**ISO LOAD INDEX SPEED SYMBOL
AT 38° C (100° F) AMBIENT TEMPERATURE
For Haul Cycles Greater than 5 km (3 miles) Round Trip**

Because of the variance between specific tires it is recommended that at the time of purchase you check with your tire supplier for the manufacturer's specific TKPH ratings for the tires purchased.

MICHELIN RADIAL PLY — WIDE BASE SIZES

Industry Code	E-2	E-3	E-4		E-7
Tread Design	XL	XADN	XADT	X-SUPER TERRAIN	XS
Custom Code	B	—	—	—	—
20.5R25		177B	177B		
23.5R25	188E	185B*		185B	
26.5R25	195E	193B*		193B	
29.5R25		200E*		200B	196E

*Speed option available via special field request.

**ISO LOAD INDEX SPEED SYMBOL
 AT 38° C (100° F) AMBIENT TEMPERATURE
 For Haul Cycles Greater than 5 km (3 miles) Round Trip**

Because of the variance between specific tires it is recommended that at the time of purchase you check with your tire supplier for the manufacturer's specific TKPH ratings for the tires purchased.

MICHELIN RADIAL PLY – 95 SERIES SIZES

Industry Code	E-2			
	XL	S	XSNO+	XV
Tread Design	B	—	—	C
Custom Code	B	—	—	C
385/95R24		170E	170E	
385/95R25		170E	170E	
445/95R25	177E			
505/95R25				183E

**ISO LOAD INDEX SPEED SYMBOL
 AT 38° C (100° F) AMBIENT TEMPERATURE
 For Haul Cycles Greater than 5 km (3 miles) Round Trip**

Because of the variance between specific tires it is recommended that at the time of purchase you check with your tire supplier for the manufacturer's specific TKPH ratings for the tires purchased.

MICHELIN RADIAL PLY – 80 SERIES SIZES

Industry Code	E-2	E-3
	XL	XMP
Tread Design	B	—
Custom Code	B	—
395/80R25		165E
525/80R25	179E	

**ISO LOAD INDEX SPEED SYMBOL
 AT 38° C (100° F) AMBIENT TEMPERATURE
 For Haul Cycles Greater than 5 km (3 miles) Round Trip**

Because of the variance between specific tires it is recommended that at the time of purchase you check with your tire supplier for the manufacturer's specific TKPH ratings for the tires purchased.

MICHELIN RADIAL PLY – 65 SERIES SIZES

Industry Code	E-3	E-7
Tread Design	XAD 65	XS
Custom Code	–	–
525/65R20.5		173F
650/65R25	180B	
750/65R25	190B	
850/65R25	196B	
775/65R29	195B	
875/65R29	203B	

TKPH RATINGS
AT 38° C (100° F) AMBIENT TEMPERATURE
For Haul Lengths of 32 km (20 miles) or Less One Way
Maximum Speed Not To Exceed 48 km (30 miles) per Hour

Because of the variance between specific tires it is recommended that at the time of purchase you check with your tire supplier for the manufacturer's specific TKPH ratings for the tires purchased.

TRIANGLE RADIAL PLY – CONVENTIONAL SIZES

Industry Code	E-2						E-3			E-4								
	TB536			TB586			TB526			TB516S			TB526S			TL558S		
	T3	T2	T1	T3	T2	T1	T3	T2	T1	T3	T2	T1	T3	T2	T1	T3	T2	T1
14.00R24 TKPH	–	–	–							–	–	–						
14.00R25 TKPH	–	–	–	–	–	–	–	–	–	–	–	–						
16.00R25 TKPH				–	–	–										–	–	–
18.00R25 TKPH				–	–	–				–	–	–				–	–	–
18.00R33 TKPH													270	190	160			
21.00R33 TKPH													300	230	190			
21.00R35 TKPH													–	–	–			
24.00R35 TKPH													390	350	280			

TKPH RATINGS
AT 38° C (100° F) AMBIENT TEMPERATURE
For Haul Lengths of 32 km (20 miles) or Less One Way
Maximum Speed Not To Exceed 48 km (30 miles) per Hour

Because of the variance between specific tires it is recommended that at the time of purchase you check with your tire supplier for the manufacturer's specific TKPH ratings for the tires purchased.

TRIANGLE RADIAL PLY – WIDE BASE SIZES

Industry Code	E-2						E-3						E-4								
	TB515			TM518			TB516			TL528			TL559			TL568+			TB598S		
	T3	T2	T1	T3	T2	T1	T3	T2	T1	T3	T2	T1	T3	T2	T1	T3	T2	T1	T3	T2	T1
17.5R25 TKPH	–	–	–				–	–	–												
20.5R25 TKPH	–	–	–				–	–	–												
23.5R25 TKPH				260	200	170	230	170	145	230	190	150							185	135	115
26.5R25 TKPH							240	190	155				–	–	–				195	150	125
29.5R25 TKPH							290	230	180										225	175	135
29.5R29 TKPH							–	–	–												
33.25R29 TKPH																–	–	–			

TKPH RATINGS
AT 38° C (100° F) AMBIENT TEMPERATURE
For Haul Lengths of 32 km (20 miles) or Less One Way
Maximum Speed Not To Exceed 48 km (30 miles) per Hour

Because of the variance between specific tires it is recommended that at the time of purchase you check with your tire supplier for the manufacturer's specific TKPH ratings for the tires purchased.

TRIANGLE RADIAL PLY – 65 SERIES SIZES

Industry Code		E-3		
Tread Design		TB598		
Custom Code		T3	T2	T1
750/65R25	TKPH	250	190	130
775/65R29	TKPH	—	—	—
875/65R29	TKPH	360	285	230

TKPH RATINGS
AT 38° C (100° F) AMBIENT TEMPERATURE
For Haul Lengths of 32 km (20 miles) or Less One Way
Maximum Speed Not To Exceed 48 km (30 miles) per Hour

Because of the variance between specific tires it is recommended that at the time of purchase you check with your tire supplier for the manufacturer's specific TKPH ratings for the tires purchased.

EUROTIRE RADIAL PLY

Industry Code		E-4				
		DR004	EROCK	ETRAC	ETRAC ADT	LR004
29.5R25	TKPH				225	225
18.00R33	TKPH	192		192		
21.00R33	TKPH			240		
24.00R35	TKPH			357		
27.00R49	TKPH			512		
33.00R51	TKPH		660	660		

NOTE: Consult Eurotire for TKPH ratings on haul cycles greater than 5 km (3 miles).

TKPH RATINGS
AT 38° C (100° F) AMBIENT TEMPERATURE
For Haul Lengths of 32 km (20 miles) or Less One Way
Maximum Speed Not To Exceed 48 km (30 miles) per Hour

Because of the variance between specific tires it is recommended that at the time of purchase you check with your tire supplier for the manufacturer's specific TKPH ratings for the tires purchased.

EUROTIRE BIAS PLY

Industry Code		E-3		E-4		
		U-11	U-12	U-11	U-12	U-14
24.00-35	TKPH					263
27.00-49	TKPH				385	
33.00-51	TKPH		580	511	511	
36/90-51	TKPH				520	
37.00-57	TKPH			635		
40.00-57	TKPH			685		
46/90-57	TKPH	910		695		

NOTE: Consult Eurotire for TKPH ratings on haul cycles greater than 5 km (3 miles).

TIRE AND RIM ASSOCIATION RATINGS

While the TKPH Rating System provides a method to determine the tire's work capacity, Tire and Rim Association Ratings provide a guide for evaluating a tire's structural capacity. These two rating systems should be used in conjunction to evaluate tire performance.

TIRE SELECTION

Selecting the optimum tire for a given application is particularly critical for earthmoving. The machines have the capability to outperform the tires and, unless proper practices are observed, very costly premature tire failures can occur. Job conditions vary greatly throughout the world, as well as within any given job site, and selecting the optimum tire requires careful consideration of all factors involved. In general, the tire manufacturer should be consulted before making the selection for any given application. In some cases, the tire manufacturer can fabricate tires specifically tailored for a given job site.

For those applications where wear is extremely slow, especially as a result of only occasional operation throughout the year, the cheapest lightweight tire needs to be given strong consideration.

As job conditions become severe, the following factors should be evaluated in selecting a tire:

Transport or Load-and-carry —

- TKPH (primary consideration)
- Minimum approved star/ply rating or greater
- Largest optional size
- Thickest tread commensurate with TKPH
- Most cut resistant tread commensurate with TKPH
- Belted construction

Grader —

- Tire load rating suitable for maximum equipped machine weight (See Tire Load Worksheet on next page)
- Application specific tire (snow, construction, road maintenance, mining, general purpose, all season)
- Bias or radial based on initial cost, puncture resistance, rolling resistance, life to retread/repair

Loader or Dozer —

- Minimum approved ply rating or greater
- Largest optional size
- Thickest tread
- Thickest available undertread
- Buttressed shoulder
- Most cut resistant tread
- Belted construction
- Lowest aspect ratio

All tires should be operated at the tire manufacturer's recommended inflation pressure for a given application. Inflation pressure should be checked every working day with an accurate gauge. This gauge should be checked against a known standard such as a dead weight tester at least once a month.

Excess loads may result from factors such as varying material density, field modifications to equipment, mud accumulation, load transfer, etc. Only under these conditions may the actual in service tire load exceed the rated machine load. When excess loads are encountered, cold inflation pressures **must** be increased to compensate for higher loads. Increase tire inflation pressure 2% for each 1% increase in load.

	Maximum Excess	
	Load	Pressure
Bias Ply	15%	30%
Radial Ply	7%	14%

The above loads will result in reduced tire performance and must be approved by the tire manufacturer.

The use of chains is difficult to justify except under a few conditions. Chains are very costly and heavy, and require more maintenance than most operations can provide. On some models sufficient clearance does not exist for chains with all tire combinations. Extensive modifications may be required if chains are needed for the job.

Foam filling tires is normally not recommended due to high cost and lack of local filling facilities. Its use should be confined to loader and dozer applications where penetrations occur almost daily. If foam is used be sure to adhere to recommended equivalent pressures of nitrogen and use highest available ply rating. Consult tire manufacturer for specific warranty concerns.

TIRE SELECTION GUIDE

Material	Road or Ground Condition	Treads		
		Haul Trucks and Wheel Tractor-Scrapers	Wheel Tractors or Wheel Loaders	Graders*
Silt and clay: – No rock – High moisture content	– Good varying to poor – High rolling resistance	E-2 (Traction)	L-2 (Traction)	G-2 (Traction)
Silt and clay: – Some rock – Variable moisture content	– Good varying to poor	E-3 (Rock) E-2 (Traction)	L-3/L-4/L-5 (Rock) L-2 (Traction)	G-3/G-4 (Rock) G-2 (Traction)
Silt/clay/gravel/sand: – Low moisture content	– Excellent to good – Firm surface	E-3/E-4 (Rock)	L-3/L-4/L-5 (Rock)	G-3/G-4 (Rock) L-3/L-4/L-5 (Rock)
Silt/clay/gravel/sand: – High moisture content	– Poor – Rutted – Pot holes	E-3/E-4 (Rock)	L-3/L-4/L-5 (Rock)	G-3/G-4 (Rock) L-3/L-4/L-5 (Rock)
Blasted rock	Hard surface, rough	E-4 (Rock)	L-5 (Rock) L-5S (Smooth)	G4 (Rock) L-4/L-5 (Rock)
Sand: – Very low silt/clay content	Good to fair surface	E-3 (Rock) E-7 (Flotation)	L-3 (Rock) L-3S (Smooth)	G-3 (Rock) Low pressure

*NOTE: In some cases, an L type tire is appropriate for use on a Grader application, consult your tire supplier for proper tire selection.

RECOMMENDED MOUNTING LUBRICANTS FROM SUPPLIERS

The following table documents tire supplier recommendations for Tire Mounting Compounds.

Tire Mounting Compounds

Tire-Slick
 Michelin “Tigre 80” Grease
 REMA Tiptop
 Fuchs Silkolene
 IZY-SEEL

TIRE SUPPLIER RECOMMENDED COLD INFLATION PRESSURES

The following tables present commonly found Caterpillar and the *tire suppliers’* recommended cold inflation pressures for tires on Cat machines. For inflation pressures of tire suppliers not listed please obtain them directly from the respected supplier.

The inflation pressure is based on a ready-to-work vehicle weight, rated payload, and average operating conditions. **Pressures for each application may need to be varied from those shown and should always be obtained from your tire supplier.**

Pressures for all tires apply to rib, traction, rock, deep tread, and super deep tread tires.

NOTE: Caterpillar recommends using dry nitrogen (N₂) gas for both tire inflation and pressure adjustments on all current and past production machines.

EXCAVATORS

For complete tire data and inflation pressures, see the Excavator section in this handbook.

Optimal pressures may vary depending on specific applications and working conditions. Always consult your local tire supplier for operating pressures.

STANDARD COLD INFLATION PRESSURES SKIDDERS — Bias Ply

Model	Tire Size	Ply Rating	Inflation Pressure			
			Front		Rear	
			kPa	psi	kPa	psi
525C	30.5L-32	20	170	25	170	25
525D	30.5L-32	20	241	35	241	35
535C	30.5L-32	26	170	25	170	25
535D	30.5L-32	26	310	45	310	45
545C	DH35.5LB-32	20	170	25	170	25
	DH35.5LB-32	24	170	25	170	25
545D	35.5L-32	20	207	30	207	30
555D	35.5L-32	24	241	35	241	35

Optimal pressures may vary depending on specific applications and working conditions. Always consult your local tire supplier for operating pressures.

SKID STEER LOADERS — Bias and Bias Belted

Model	Tire Size	Ply Rating	Inflation Pressure									
			Galaxy Beefy Baby		Cat Premium Conventional		Cat XD (Extreme Duty)		Goodyear SGLSS		Goodyear UGL	
			kPa	psi	kPa	psi	kPa	psi	kPa	psi	kPa	psi
216B3	7-15	6			415	60						
	10-16.5	6							240	35		
	10-16.5	8	345	50	310	45						
	31x15.5-15	8									310	45
226B3	7-15	6			415	60						
	10-16.5	6							240	35		
	10-16.5	8	345	50	310	45						
	31x15.5-15	8									310	45
236D	10-16.5	6							240	35		
	10-16.5	8	345	50	410	60						
	10-16.5	10					345	50				
	12-16.5	10	310	45	310	44.95						
242D	10-16.5	6							240	35		
	10-16.5	8	345	50	410	60						
	10-16.5	10					345	50				
	12-16.5	10	310	45	310	44.95						
246D	12-16.5	10	310	45	310	45						
	12-16.5	14					345	50				
262D	12-16.5	10	310	45	310	45						
	12-16.5	14					345	50				
272D	12-16.5	10	310	45	310	45	310	45				
	12-16.5	14			345	50	345	50				
	14-17.5	14			415	60	415	60				
272D XHP	14-17.5	14			415	60	415	60				

Optimal pressures may vary depending on specific applications and working conditions. Always consult your local tire supplier for operating pressures.

TELEHANDLERS

Model	Tire Size	Ply Rating	Inflation Pressure	
			kPa	psi
TH220B	15.5/80-24	16	250	36
	17.5LR24xM27	12	310	45
	15.5-25 SGL-2A	12	410	59
TH330B	13.00-24 SGG-2ATL	12	370	54
	13.00-24 Cat	12	450	65
	440/70R24xM37 (17.5R24)	Radial	350	51
	550/70R24xM37 (19.5LR24)	Radial	350	51
	15.5-25 SGL-2A	12	320	46
	15.5-25 Cat	12	400	58
	15.5R25 XHA	Radial	400	58
TH255	12x16.5	12	551	80
	14x17.5	10	482	70
TH336	15.5/80-24 TR01	14	410	59
TH406	15.5/80-24 SGL-2A	16	400	58
	400/80-24-400	—	400	58
	460/70R24	Radial	420	61
	15.5-25 SGL	8, 12	400	58
TH337	15.5/80-24 TR01	14	410	59
TH407	15.5/80-24 SGL-2A	16	400	58
	400/80-24-400	—	400	58
	440/80-24-350	—	350	51
	460/70R24	Radial	420	61
	500/70R24	Radial	300	44
	15.5-25 SGL	8, 12	400	58
TH417	14.00-24 TG02	16	425	62
TH514	14.00-24 SGG-2A	16	525	76
TL642	13.00-24	12	448	65
TL963	13.00R24	★	482	70
	15.5-25	12	448	65
	15.5R24	★	482	70
	370/75-28	14	524	76
	TL642C	13.00x24	12	448
TL943C	15.5-25	12	400	58
	370/75-28	14	524	76
	TL1055	14.00-24	12	448
TL1255	14.00R24	★	482	70
	17.5-25	12	448	65
	17.5R25	★	482	70
	400/75-28	16	524	76
	TL1055C	14.00-24	12	448
TL1255C	17.5-25	12	448	65
	400/75-28	16	524	76

NOTE: See machine OMM for operating pressures. <http://onlineexpress2.jlg.com/CAGUI/default.aspx>.

Optimal pressures may vary depending on specific applications and working conditions. Always consult your local tire supplier for operating pressures.

BACKHOE LOADERS (Front)

Model	Tire Size	Ply/Speed Symbol	Inflation Pressure	
			kPa	psi
415F2, 416F2, 420F2, 422F2	11L-16	12 PLY	352	51
415F2, 416F2, 420F2	12-16.5	10 PLY	448	65
415F2, 416F2, 420F2, 422F2, 427F2, 428F2, 430F2, 432F2	12.5/80-18	10 PLY/12 PLY/14 PLY	317/372/310	46/54/45
422F2, 427F2, 428F2, 432F2	340/80-18	143 A8	345	50
415F2, 416F2, 420F2, 430F2	320/80R18	143 B	400	58
415F2, 416F2, 420F2, 430F2	340/80R18	143 A8	324	47
422F2, 427F2, 428F2, 432F2	340/80R18	143 A8	386	56
427F2, 428F2, 432F2	340/80-20	144 A8	324	47
427F2, 428F2, 432F2	340/80R20	144 A8	372	54
450F2	15-19.5	12 PLY	414	60

BACKHOE LOADERS (Rear)

Model	Tire Size	Ply/Speed Symbol	Inflation Pressure	
			kPa	psi
415F2, 416F2, 420F2, 430F2	19.5L-24	12 PLY	234	34
415F2, 416F2, 420F2, 430F2	500/70R24	157 B/164 A8	317/331	46/48
415F2, 416F2, 420F2, 430F2, 450F2	21L-24	16 PLY/18 PLY	276/303	40/44
434F2, 444F2	440/80-24	168 A8	317	46
434F2, 444F2	440/80R24	161 A8	324	47
427F2, 428F2, 432F2	18.4-26	12 PLY	248	36
427F2, 428F2, 432F2	480/80-26	160 A8	282	41
427F2, 428F2, 432F2	480/80R26	160 A8	282	41
422F2, 427F2, 428F2, 432F2	16.9-28	12 PLY	262	38
422F2, 427F2, 428F2, 432F2, 434F2, 444F2	440/80-28	156 A8	282	41
422F2, 427F2, 428F2, 432F2	440/80R28	156 A8/163 A8	282/317	41/46
434F2, 444F2	440/80R28	156 A8/163 A8	310/317	45/46

Optimal pressures may vary depending on specific applications and working conditions. Always consult your local tire supplier for operating pressures.

PAVING PRODUCTS — Bias Ply and Radial Pneumatic Tires

Model	Tire Size	Ply Rating	Inflation Pressure ^{1,2,3}	
			kPa	psi
WHEEL ASPHALT PAVERS				
AP500E/BG500E/AP500F	17.5R25	★	448	65
AP600D/BG600D	16.00-24	12	345	50
	445/95R25	★★	551	80
AP600F	16.00-24	12	345	50
	445/95R25	174F	600	87
AP1000E/BG1000E	18.00-25	16	379	55
	445/95R25	★★	586	85
AP1000F	18.00-25	16	379	55
	20.5R25	★	434	63
VIBRATORY SOIL COMPACTORS				
CP44				
CS44				
CP54				
CP54B				
CS54	23.1-26	8	110	16
CS54 XT				
CS54B				
CP56	23.1-26	8	110	16
CP56B				
CS56	23.1-26	8	110	16
CS56B				
CP64	23.1-26	12	165	24
CS64	23.1-26	8	110	16
	23.1-26	12	165	24
CP68B				
CS68B				
CP74	23.1-26	8	110	16
CP74B				
CS74	23.1-26	8	110	16
	23.1-26	12	165	24
CS74B				
CP76	23.1-26	12	165	24
CS76	23.1-26	12	165	24
CS76 XT	23.1-26	12	165	24
CS78B				
PNEUMATIC ROLLERS				
PS150C	8.50/90x15	6	350	51
	7.50x15	12	760	110
PS360C	14/70x20	20	760	110

¹Inflation pressures are maximum rated tire pressures.

²Pressure varies with application for Pneumatic Tire Compactors (PS).

³Consult your local tire supplier for operating pressures.

Optimal pressures may vary depending on specific applications and working conditions. Always consult your local tire supplier for operating pressures.

MOTOR GRADERS — Bias Ply*

Model	Tire Size	Ply Rating	Inflation Pressure											
			Goodyear				Bridgestone/Firestone				Triangle			
			Front		Rear		Front		Rear		Front		Rear	
		kPa	psi	kPa	psi	kPa	psi	kPa	psi	kPa	psi	kPa	psi	
120K/K2	13.00-24	12	228	33	228	33	241	35	241	35				
	14.00-24	12, 16	172	25	172	25	250	36	250	36				
	15.5-25	12	200	29	200	29								
	17.5-25	12, 16	152	22	152	22	250	36	250	36				
120M/M2	13.00-24	12					241	35	310	45				
	14.00-24	12, 16	228	33	324	47	207	30	276	40	152	22	200	29
	17.5-25	12, 16					207	30	241	35	152	22	172	25
140K/K2	14.00-24	12, 16	172	25	172	25	250	36	250	36				
	17.5-25	12, 16	172	25	172	25	250	36	250	36				
140M/M3	14.00-24	12, 16	248	36	352	51	207	30	241	35	200	29	290	42
	17.5-25	12, 16	228	33	324	47	207	30	276	40	200	29	255	37
160K	14.00-24	12, 16	200	29	200	29	250	36	250	36				
	17.5-25	12, 16	200	29	200	29	250	36	250	36				
160M/M2/M3	14.00-24	12, 16	248	36	372	54	207	30	276	40				
	17.5-25	12, 16					207	30	276	40				
12K	13.00-24	12	276	40	276	40								
	14.00-24	12, 16	200	29	200	29	250	36	250	36				
	15.5-25	12	248	36	248	36								
	17.5-25	12, 16	172	25	172	25	250	36	250	36				
12M/M3	13.00-24	12					241	35	310	45				
	14.00-24	12, 16	248	36	352	51	207	30	276	40	172	25	290	42
	15.5-25	12					207	30	241	35				
	17.5-25	12, 16	228	33	324	47	207	30	241	35	172	25	255	37
14L	20.5-25	16, 20	248	36	303	44	172	25	241	35				
14M	16.00-24	16	172	25	324	47	207	30	310	45				
	20.5-25	16, 20	172	25	303	44	241	35	379	55				
16M	18.00-25	16					207	30	241	35				
	23.5-25	16, 20	172	25	276	40	207	30	276	40				
24M	29.5-29	28					345	50	379	55				

*Consult your local tire supplier for proper ply rating.

Optimal pressures may vary depending on specific applications and working conditions. Always consult your local tire supplier for operating pressures.

MOTOR GRADERS — Radial Ply

Model	Tire Size	Ply Rating	Inflation Pressure															
			Michelin				Goodyear				Bridgestone/ Firestone				Titan			
			Front		Rear		Front		Rear		Front		Rear		Front		Rear	
kPa	psi	kPa	psi	kPa	psi	kPa	psi	kPa	psi	kPa	psi	kPa	psi	kPa	psi			
120K/K2	13.00R24	★	207	30	207	30												
	14.00R24	★	207	30	207	30	228	33	228	33	310	45	310	45				
	15.5R25	★	207	30	207	30	Not Approved											
	17.5R25	★	207	30	207	30	172	25	172	25	276	40	276	40				
120M/M2	13.00R24	★								276	40	379	55					
	14.00R24	★	241	35	345	50	276	40	372	54	241	35	359	52				
	15.5R25	★					Not Approved				241	35	310	45				
	17.5R25	★	207	30	276	40	228	33	303	44	207	30	241	35				
140K/K2	14.00R24	★	207	30	241	35	248	36	248	36	310	45	310	45				
	17.5R25	★	207	30	207	30	200	29	200	29	276	40	276	40				
140M/M3	14.00R24	★	276	40	345	50	303	44	372	54	241	35	345	50				
	17.5R25	★	207	30	276	40	248	36	303	44	221	32	290	42				
160K	14.00R24	★	207	30	241	35	248	36	248	36	310	45	310	45				
	17.5R25	★	207	30	241	35	200	29	200	29	276	40	276	40				
160M/M2/M3	14.00R24	★	276	40	345	50	324	47	427	62	241	35	359	52				
	17.5R25	★	207	30	276	40	248	36	352	51	241	35	310	45				
12K	13.00R24	★	207	30	276	40	324	47	324	47								
	14.00R24	★	207	30	241	35	248	36	248	36	310	45	310	45				
	15.5R25	★	207	30	207	30	Not Approved											
	17.5R25	★	207	30	207	30	200	29	200	29	276	40	276	40				
12M/M3	13.00R24	★					Not Approved				276	40	379	55				
	14.00R24	★	207	30	310	45	303	44	372	54	262	38	359	52				
	17.5R25	★	207	30	241	35	248	36	303	44	207	30	290	42				
14L	20.5R25	★	207	30	207	30	248	36	303	44	172	25	241	35				
	550/65R25	★	207	30	207	30												
14M	16.00R24	★	310	45	345	50	248	36	427	62	207	30	359	52				
	20.5R25	★	207	30	310	45	248	36	324	47	207	30	310	45	207	30		
	550/65R25	★	310	45	352	51												
16M	23.5R25	★, ★★	207	30	310	45	172	25	324	47	207	30	290	42	207	30		
24M	29.5R29	★, ★★	310	45	379	55	324	47	476	69	345	50	414	60				

NOTE: These are general pressures. For applications such as slope and ditching service, the inflation pressures should be increased by 100 kPa (15 psi) with NO increase in carrying capacity. Any extreme conditions should be referred to your local tire supplier OR representative for recommended pressures, sizes, patterns, and compounds for specific application. The recommended inflation pressures provided are a starting point for the machine shown.

Standard Cold Inflation Pressures
 ● Wheel Tractor-Scrapers — Bias and Radial Ply

Optimal pressures may vary depending on specific applications and working conditions. Always consult your local tire supplier for operating pressures.

WHEEL TRACTOR-SCRAPERS — Bias Ply

Model	Tire Size	Ply Rating	Inflation Pressure											
			Goodyear		Bridgestone/Firestone		Titan							
			Front	Rear	Front	Rear	Front	Rear	Front	Rear				
			kPa	psi	kPa	psi	kPa	psi	kPa	psi	kPa	psi	kPa	psi
621K	33.25-29	26, 32, 38					379	55	379	55	414	60	345	50
623K	33.25-29	26, 32, 38					379	55	379	55	414	60	345	50
627K	33.25-29	26, 32, 38					379	55	379	55	414	60	414	60
631G	37.25-35	36, 42	448	65	428	62	448	65	448	65				
637G	37.25-35	36, 42	448	65	427	62	448	65	448	65				
657G	37.5-39	52												

WHEEL TRACTOR-SCRAPERS — Radial Ply

Model	Tire Size	Ply Rating	Inflation Pressure											
			Michelin		Goodyear		Bridgestone							
			Front	Rear	Front	Rear	Front	Rear	Front	Rear				
			kPa	psi	kPa	psi	kPa	psi	kPa	psi	kPa	psi	kPa	psi
621K	29.5R29	★★									517	75	517	75
	33.25R29	★★	448	65	414	58					448	65	414	57
623K	29.5R29	★★									517	75	517	75
	33.25R29	★★	448	65	414	60					462	67	434	63
627K	29.5R29	★★									517	75	517	75
	33.25R29	★★	476	69	476	69					483	70	483	70
631G	37.25R35	★★	552	80	476	69	476	69	427	62	552	80	552	80
637G	37.25R35	★★	552	80	503	73	537	78	503	73	552	80	552	80
657G	40.5/75R39	★★	600	87	524	76	586	85	579	84	621	90	621	90

Optimal pressures may vary depending on specific applications and working conditions. Always consult your local tire supplier for operating pressures.

ARTICULATED TRUCKS — Radial Ply

Model	Tire Size	Ply Rating	Inflation Pressure											
			Michelin						Goodyear					
			Front		Center		Rear		Front		Center		Rear	
		kPa	psi	kPa	psi	kPa	psi	kPa	psi	kPa	psi	kPa	psi	
725C	23.5R25	★★	450	65	400	58	400	58	400	58	372	54	372	54
	750/65R25	★★												
730C	23.5R25	★★	500	73	450	65	450	65	400	58	372	54	372	54
	750/65R25	★★												
730C EJ	23.5R25	★★												
	750/65R25	★★	400	58	525	76	525	76						
735C	26.5R25	★★	450	65	500	73	500	73	503	73	552	80	552	80
	775/65R25	★★							400	58	427	62	427	62
740C EJ	29.5R25	★★	400	58	500	73	500	73	400	58	503	73	503	73
	875/65R25	★★							372	54	448	65	448	65
745C	29.5R25	★★	400	58	500	73	500	73	476	69	503	73	503	73
	875/65R25	★★							427	62	448	65	448	65

ARTICULATED TRUCKS — Radial Ply

Model	Tire Size	Ply Rating	Inflation Pressure											
			Bridgestone						Yokohama					
			Front		Center		Rear		Front		Center		Rear	
		kPa	psi	kPa	psi	kPa	psi	kPa	psi	kPa	psi	kPa	psi	
725C	23.5R25	★★	476	69	414	60	414	60	503	73	427	62	427	62
	750/65R25	★★	379	55	345	50	345	50						
730C	23.5R25	★★	476	69	414	60	414	60	524	76	490	71	490	71
	750/65R25	★★	379	55	345	50	345	50						
730C EJ	23.5R25	★★	414	60	586	85	572	83	365	53	524	76	524	76
	750/65R25	★★	345	50	448	65	448	65						
735C	26.5R25	★★	496	72	538	78	538	78	524	76	483	70	483	70
	775/65R25	★★												
740C EJ	29.5R25	★★	414	60	490	71	490	71	434	63	503	73	503	73
	875/65R25	★★	345	50	393	57	386	56						
745C	29.5R25	★★	483	70	496	72	496	72	503	73	490	71	490	71
	875/65R25	★★	379	55	393	57	393	57						

Standard Cold Inflation Pressures
 • Mining & Off-Highway Trucks — Bias and Radial Ply

Optimal pressures may vary depending on specific applications and working conditions. Always consult your local tire supplier for operating pressures.

MINING & OFF-HIGHWAY TRUCKS — Bias Ply

Model	Tire Size	Ply Rating	Inflation Pressure											
			Goodyear		Bridgestone/Firestone		Eurotire							
			Front	Rear	Front	Rear	Front	Rear						
			kPa	psi	kPa	psi	kPa	psi	kPa	psi	kPa	psi		
773E	24.00-35	42, 48	572	83	572	83	621	90	621	90	586	85	552	80
773G	24.00-35	42, 48					621	90	621	90	586	85	552	80
775G	24.00-35	42, 48	648	94	648	94	621	90	621	90				
777D	27.00-49	48	572	83	572	83	621	90	621	90	621	90	621	90
777G	27.00-49	48	572	83	572	83	621	90	621	90	621	90	621	90
785C	33.00-51	58									725	105	725	105
785D	33.00-51	58									725	105	725	105
789D														
793D	40.00-57	68									715	104	715	104
793F	40.00-57	68									715	104	715	104
MT5300D AC														
795F AC														
797F AC														

MINING & OFF-HIGHWAY TRUCKS — Radial Ply

Model	Tire Size	Ply Rating	Inflation Pressure											
			Michelin		Goodyear		Bridgestone							
			Front	Rear	Front	Rear	Front	Rear						
			kPa	psi	kPa	psi	kPa	psi	kPa	psi	kPa	psi		
770G	18.00R33	★★, ★★★	752	109	752	109	800	116	800	116	800	116	800	116
772G	21.00R33	★★	703	102	703	102	703	102	703	102	703	102	703	102
773E	24.00R35	★★	572	83	572	83	627	91	627	91	689	100	689	100
773G	24.00R35	★★	703	102	703	102	648	94	648	94	689	100	689	100
775G	24.00R35	★★	724	105	724	105	744	108	744	108	689	100	689	100
777D	27.00R49	★★	703	102	103	102	703	102	710	103	703	102	703	102
777G	27.00R49	★★	689	100	689	100	103	102	731	106	703	102	703	102
785C	33.00R51	★★	724	105	724	105	800	116	800	116	793	115	793	115
785D	33.00R51	★★	724	105	724	105	800	116	800	116	793	115	793	115
789D	37.00R57	★★	627	91	627	91					758	110	758	110
	40.00R57	★★	552	80	552	80								
793D	40.00R57	★★	724	105	724	105					724	105	724	105
	46/90R57	★★					724	105	724	105	793	115	793	115
793F	40.00R57	★★	724	105	724	105					724	105	724	105
	46/90R57	★★					724	105	724	105	793	115	793	115
	50/80R57	★★	669	97	669	97								
MT5300D AC	53/80R63	★★	Consult Michelin		Consult Goodyear						758	110	758	110
795F AC	56/80R63	★★	655	95	621	90	Not Approved		Not Approved					
	59/80R63	★★	Not Approved				703	102	703	102	703	102	703	102
797F	59/80R63	★★	689	100	689	100					724	105	724	105

Optimal pressures may vary depending on specific applications and working conditions. Always consult your local tire supplier for operating pressures.

MINING & OFF-HIGHWAY TRUCKS – Radial Ply

Model	Tire Size	Ply Rating	Inflation Pressure											
			Titan				Triangle				Eurotire			
			Front		Rear		Front		Rear		Front		Rear	
			kPa	psi	kPa	psi	kPa	psi	kPa	psi	kPa	psi	kPa	psi
770G	18.00R33	★★, ★★★	793	115	827	120	800	116	800	116	700	102	700	102
772G	21.00R33	★★					700	102	700	102	700	102	700	102
773E	24.00R35	★★	689	100	689	100	700	102	700	102	700	102	700	102
773G	24.00R35	★★	689	100	689	100	700	102	700	102	700	102	700	102
775G	24.00R35	★★	689	100	689	100	700	102	700	102	700	102	700	102
777D	27.00R49	★★	724	105	724	105	724	105	724	105	700	102	700	102
777G	27.00R49	★★	724	105	724	105	424	105	724	105	700	102	700	102
785C	33.00R51	★★												
785D	33.00R51	★★												
789D	37.00R57	★★												
	40.00R57	★★												
793D	40.00R57	★★												
	46/90R57	★★												
793F	40.00R57	★★												
	46/90R57	★★												
	50/80R57	★★												
MT5300D AC	53/80R63	★★												
795F AC	56/80R63	★★												
	59/80R63	★★												
797F	59/80R63	★★												

Optimal pressures may vary depending on specific applications and working conditions. Always consult your local tire supplier for operating pressures.

WHEEL LOADERS — Bias and Bias Belted

Model	Tire Size	Ply Rating	Inflation Pressure												
			Goodyear				Bridgestone/Firestone				Yokohama				
			Front		Rear		Front		Rear		Front		Rear		
kPa	psi	kPa	psi	kPa	psi	kPa	psi	kPa	psi	kPa	psi				
910K	16.9-24	10, 12										250/280*	36/41*	190/225*	28/33*
910K	15.5-25	12	225/250**	33/36**	200	29									
914K	17.5-25	12, 16	225	33	200	29	240	35	210	30					

*Yokohama (16.9-24) recommends 250/190 kPa (36/28 psi) front/rear pressures for 910K Standard Lift, 280/225 kPa (41/33 psi) front/rear pressures for 910K High Lift.
 **Goodyear (15.5-25) recommends 225/200 kPa (33/29 psi) front/rear pressures for 910K Standard Lift, 250/200 kPa (36/29 psi) front/rear pressures for 910K High Lift.

Model	Tire Size	Ply Rating	Inflation Pressure											
			Goodyear				Bridgestone/Firestone				Titan			
			Front		Rear		Front		Rear		Front		Rear	
kPa	psi	kPa	psi	kPa	psi	kPa	psi	kPa	psi	kPa	psi	kPa	psi	
924H	17.5-25	12	400	58	300	44	380	55	275	40				
	20.5-25	12	250	36	210	30	275	40	210	30				
924Hz	17.5-25	12	400	58	300	44	380	55	275	40				
	20.5-25	12	400	58	300	44	275	40	210	30				
928Hz	17.5-25	12	400	58	300	44	380	55	275	40				
	20.5-25	12	400	58	300	44	275	40	210	30				
	23.1-26	14												
930H	17.5-25	12	400	58	300	44	380	55	275	40				
	20.5-25	12	400	58	300	44	275	40	210	30				
	23.1-26	14												
938H	20.5-25	16	352	51	248	36	345	50	207	30				
	20.5-25	20	372	54	248	36	345	50	207	30				

For pressures not listed, consult your local tire supplier for operating pressures.

Optimal pressures may vary depending on specific applications and working conditions. Always consult your local tire supplier for operating pressures.

WHEEL LOADERS — Bias and Bias Belted

Model	Tire Size	Ply Rating	Inflation Pressure											
			Goodyear				Bridgestone/Firestone				Titan			
			Front		Rear		Front		Rear		Front		Rear	
		kPa	psi	kPa	psi	kPa	psi	kPa	psi	kPa	psi	kPa	psi	
950H	23.5-25	16, 20	375	54	250	36	345	50	210	30				
950K	23.5-25	16, 20					345	50	345	50				
950M	23.5-25	16, 20, 24	379	55	241	35	345	50	207	30				
	725/70-25	16									345	50	240	35
962H	23.5-25	16, 20	400	58	250	36	380	55	240	35				
962K	23.5-25	16, 20					380	55	240	35				
962M	23.5-25	16, 20	414	60	241	35	380	55	240	35				
	725/70-25	16									380	55	240	35
966H	26.5-25	20, 24, 26	375	54	225	33	415	60	275	40				
966K	26.5-25	20, 24, 26	450	65	300	44	415	60	275	40				
966M	26.5-25	20, 24, 26	400	58	276	40	415	60	345	50				
972H	26.5-25	20, 24, 26	400	58	225	33	450	65	275	40				
972K	26.5-25	20, 24, 26	450	65	300	44	450	65	275	40				
972M	26.5-25	20, 24, 26	448	65	300	44	450	65	275	40				
980H	29.5-25	22, 28	430	62	275	40	586	85	380	55				
980K	29.5-25	22, 28					550	80	380	55				
980M	29.5-25	22, 28	448	65	276	40	586	85	380	55				
988K*	35/65-33	36, 42	627	91	427	62	655	95	414	60	793	115	483	70
990K	41.25/70-39	42	552	80	352	51	586	85	414	60	724	105	448	65
992K	45/65-45	46, 58	627	91	427	62	724	105	483	70	827	120	724	105
993K	50/65-51	62					724	105	483	70				
994K	53.5/85-57	76					724	105	483	70				
	58/85-57	84					724	105	483	70				

*Goodyear recommended 600/400 kPa (87/58 psi) front/rear pressures for standard machine and 627/427 kPa (91/62 psi) for high-lift machine. Bridgestone/Firestone inflation pressure for Giant loader tires (992K and above) are in reference to applications without chains. For use with chains please consult your Bridgestone/Firestone representative.
 For pressures not listed, consult your local tire supplier for operating pressures.

Optimal pressures may vary depending on specific applications and working conditions. Always consult your local tire supplier for operating pressures.

WHEEL LOADERS — Radial Ply

Model	Tire Size	Ply Rating	Inflation Pressure											
			Michelin				Goodyear				Dunlop			
			Front		Rear		Front		Rear		Front		Rear	
kPa	psi	kPa	psi	kPa	psi	kPa	psi	kPa	psi	kPa	psi			
906K/M	335/80R18													
907K/M	340/80R18 405/70R18		360	52	270	39					350	51	225	33
908K/M	360/80R20 400/70R20 405/70R20		360	52	260	38					375	54	250	36
910K/914K	15.5R25	★	250	36	200	29								
910K/914K	17.5R25	★	250	36	200	29	275	40	200	29				

Model	Tire Size	Ply Rating	Inflation Pressure											
			Michelin				Goodyear							
			Front		Rear		Front		Rear					
kPa	psi	kPa	psi	kPa	psi	kPa	psi	kPa	psi					
924H	17.5R25 20.5R25 550/65R25	★ ★ ★	275	40	210	30			350	51	250	36		
924Hz	17.5R25 20.5R25	★ ★	450	65	275	40			300	44	225	33		
928Hz	17.5R25 20.5R25 600/65R25	★ ★ ★	380	55	275	40			300	44	225	33		
930H	17.5R25 20.5R25	★ ★	345	50	210	30								
938H	20.5R25 550/65R25 650/65R25	★ ★ ★	379	55	276	40			450	65	305	44		
			414	60	310	45								
			414	60	310	45								

Optimal pressures may vary depending on specific applications and working conditions. Always consult your local tire supplier for operating pressures.

WHEEL LOADERS — Radial Ply

Model	Tire Size	Ply Rating	Inflation Pressure							
			Firestone				Nokian			
			Front		Rear		Front		Rear	
kPa	psi	kPa	psi	kPa	psi	kPa	psi			
906K/M	335/80R18									
907K/M	340/80R18 405/70R18		400/330*	58/48*	250	36	400	58	250 36	
908K/M	360/80R20 400/70R20 405/70R20						425	62	250 36	
910K/914K	15.5R25	★								
910K/914K	17.5R25	★								

*Firestone (340/80R18) recommends 400 kPa (58 psi) @ 10 km/h (6 mph) non-cyclic load, 330 kPa (48 psi) @ 10 km/h (6 mph) cyclic load.

Model	Tire Size	Ply Rating	Inflation Pressure							
			Bridgestone				Titan			
			Front		Rear		Front		Rear	
kPa	psi	kPa	psi	kPa	psi	kPa	psi			
924H	17.5R25	★	415	60	310	45				
	20.5R25	★	415	60	275	40				
	550/65R25	★								
924Hz	17.5R25	★	415	60	310	45				
	20.5R25	★	415	60	275	40				
928Hz	17.5R25	★								
	20.5R25	★	415	60	310	45				
	600/65R25	★								
930H	17.5R25	★								
	20.5R25	★	415	60	310	45				
938H	20.5R25	★	310	45	210	30	241	35	241 35	
	550/65R25	★								
	650/65R25	★	275	40	175	25				

Optimal pressures may vary depending on specific applications and working conditions. Always consult your local tire supplier for operating pressures.

WHEEL LOADERS — Radial Ply

Model	Tire Size	Ply Rating	Inflation Pressure							
			Michelin				Goodyear			
			Front		Rear		Front		Rear	
			kPa	psi	kPa	psi	kPa	psi	kPa	psi
950H	23.5R25*	★, ★★	450	65	240	35	450	65	305	44
	750/65R25	★	345	50	210	30				
950K	23.5R25*	★, ★★	415	60	240	35	475	69	305	44
	750/65R25	★	345	50	210	30				
950M, GC	23.5R25*	★, ★★	448	65	241	35	475	69	305	44
	750/65R25	★	345	50	310	45				
962H	23.5R25	★, ★★	450	65	275	40	475	69	305	44
962K	23.5R25	★, ★★	415	60	240	35	475	69	275	40
	750/65R25	★	345	50	240	35				
962M	23.5R25	★, ★★	448	65	240	35	500	73	325	47
	750/65R25	★	350	51	207	30				
966H	26.5R25*	★, ★★	415	60	240	35	450	65	275	40
	750/65R29	★★	380	55	240	35				
966K	26.5R25*	★, ★★	415	60	240	35	475	69	275	40
	750/65R29	★★	345	50	240	35				
966M	26.5R25*	★, ★★	414	60	240	35	475	69	305	44
	775/65R29	★★					427	62	276	40
972H	26.5R25**	★, ★★	450	65	240	35	475	69	305	44
	750/65R29	★★	380	55	240	35				
972K	26.5R25**	★, ★★	450	65	275	40	475	69	305	44
	750/65R29	★★	380	55	240	35				
972M	26.5R25**	★, ★★	420	61	280	41	524	76	325	47
	775/65R29	★★					448	65	305	44
980H	29.5R25***	★, ★★	520	75	275	40	500	73	305	44
980K	29.5R25***	★, ★★	520	75	275	40	525	76	325	47
	875/65R29	★★					475	69	305	44
980M	29.5R25***	★, ★★	517	75	275	40	552	80	352	51
	875/65R29	★★	552	80	310	45	448	65	305	44
982M	875/65R29	★	552	80	310	45	476	69	305	44
	29.5R29	★★								
988K	35/65R33	★	621	90	448	65	600	87	400	58
	35/65R33	★★	655	95	448	65				
	875/65R33****	★★					627	91	427	62
990K	45/65R39	★, ★★	586	85	345	50	552	80	352	51
992K	45/65R45	★, ★★	621	90	415	60				
	1150/65R45	★★					655	95	503	73
993K	50/65R51	★, ★★	586	85	490	71				
994K	55/80R57	★	621	90	448	65				

*Goodyear recommended 448/303 kPa (65/44 psi) front/rear pressures for 950H, 950K, and 966H.
 **Goodyear recommended 476/303 kPa (69/44 psi) front/rear pressures for 972H and 503/303 kPa (73/44 psi) for 972K.
 ***Goodyear recommended 503/303 kPa (73/44 psi) front/rear pressures for 980H and 524/324 kPa (76/47 psi) for 980K.
 ****Goodyear recommended 627/427 kPa (91/62 psi) front/rear pressures for 988H/988K standard and high lift machine and 800/600 kPa (116/87 psi) for 988H Logger and Block Handler machine.

Optimal pressures may vary depending on specific applications and working conditions. Always consult your local tire supplier for operating pressures.

WHEEL LOADERS — Radial Ply

Model	Tire Size	Ply Rating	Inflation Pressure							
			Bridgestone				Titan			
			Front		Rear		Front		Rear	
		kPa	psi	kPa	psi	kPa	psi	kPa	psi	
950H	23.5R25	★, ★★	345	50	210	30				
	750/65R25	★	310	45	175	25				
950K	23.5R25	★, ★★	345	50	210	30				
	750/65R25	★								
950M, GC	23.5R25	★, ★★	483	70	345	50	483	70	380	55
	750/65R25	★	414	60	275	40				
962H	23.5R25	★, ★★	380	55	240	35				
962K	23.5R25	★, ★★	405	59	275	40				
	750/65R25	★								
962M	23.5R25	★, ★★	483	70	345	50	552	80	380	55
	750/65R25	★	414	60	275	40				
966H	26.5R25	★, ★★	405	59	275	40				
	750/65R29	★★								
966K	26.5R25	★, ★★	405	59	275	40				
	750/65R29	★★								
966M	26.5R25	★, ★★	483	70	345	50	517	75	414	60
	775/65R29	★★	483	70	345	50				
972H	26.5R25	★, ★★	450	65	275	40				
	750/65R29	★★								
972K	26.5R25	★, ★★	450	65	275	40				
	750/65R29	★★								
972M	26.5R25	★, ★★	483	70	345	50	517	75	414	60
	775/65R29	★★	483	70	345	50				
980H	29.5R25	★, ★★	585	85	380	55				
980K	29.5R25	★, ★★	550	80	380	55				
	875/65R29	★★								
980M	29.5R25	★, ★★	585	85	380	55	621	90	448	65
	875/65R29	★★	517	75	380	55				
982M	875/65R29	★	552	80	414	60				
	29.5.R29	★★	517	75	310	45				
988K	35/65R33	★	655	95	414	60				
	35/65R33	★★	689	100	524	76	758	110	483	70
	875/65R33	★★								
990K	45/65R39	★, ★★	621	90	414	60				
992K	45/65R45	★, ★★	724	105	483	70	793	115	517	75
	1150/65R45	★★								
993K	50/65R51	★, ★★	724	105	483	70	793	115	517	75
994K	55.5/80R57	★★	724	105	483	70				

Bridgestone inflation pressure for Giant loader tires (992K and above) are in reference to applications without chains. For use with chains please consult your Bridgestone representative.

Standard Cold Inflation Pressures
 ● Log Loaders — Bias and Bias Belted
 ● Log Loaders — Radial Ply

Tires

Optimal pressures may vary depending on specific applications and working conditions. Always consult your local tire supplier for operating pressures.

LOG LOADERS — Bias and Bias Belted

Model	Tire Size	Strength Index	Inflation Pressure							
			Goodyear				Bridgestone/Firestone			
			Front		Rear		Front		Rear	
			kPa	psi	kPa	psi	kPa	psi	kPa	psi
924H Versalink™	17.5-25	12	352	51	248	36	<i>Consult Bridgestone/Firestone</i>			
	20.5-25	12								
930H Versalink	20.5-25	12								
938H	20.5-25	16, 20	400	58	276	40	310	45	207	30
950H	23.5-25	20	372	54	276	40	345	50	207	30
966H	26.5-25	20, 26	448	65	276	40	414	60	276	40
980H	29.5-25	28	427	62	276	40	586	85	379	55
988K	35/65-33	42	<i>Consult Goodyear</i>				655	95	414	60
990K	41.25/70-39	42					<i>Consult Bridgestone/Firestone</i>			

NOTE: Contact your tire supplier to obtain or confirm proper Log Loader pressures.

NOTE: Pressures for "Log Loaders" are not approved because general application of machine exceeds tire load limit.

LOG LOADERS — Radial Ply

Model	Tire Size	Strength Index	Inflation Pressure															
			Michelin				Goodyear				Bridgestone				Eurotire			
			Front		Rear		Front		Rear		Front		Rear		Front		Rear	
			kPa	psi	kPa	psi	kPa	psi	kPa	psi	kPa	psi	kPa	psi	kPa	psi	kPa	psi
924H	17.5R25	★	414	60	207	30	427	62	276	40	345	50	276	40				
	20.5R25	★	310	45	207	30	324	47	228	33	345	50	276	40				
	550/65R25	★	310	45	207	30	324	47	228	33	414	60	310	45				
930H	20.5R25	★	379	55	207	30	414	60	310	45	345	50	276	40				
	650/65R25	★	310	45	207	30					414	60	310	45				
938H	20.5R25	★	414	60	276	40	448	65	303	44	310	45	207	30				
	550/65R25	★	414	60	241	35												
	600/65R25	★																
	650/65R25	★	345	50	207	30												
950H	23.5R25	★, ★★	450	65	276	40	476	69	303	44	345	50	207	30				
	650/65R25	★	345	50	241	35												
	750/65R25	★	276	40	207	30												
966H	26.5R25	★, ★★	414	60	276	40	448	65	303	44	414	60	276	40				
	750/65R25	★	414	60	276	40												
980H	29.5R25	★, ★★	517	75	276	40	503	73	303	44	586	85	379	55	585	85	380	55
988K	35/65R33	★★					800	116	600	87	655	95	414	60				
990K	45/65R39	★, ★★	<i>Consult Michelin</i>				<i>Consult Bridgestone</i>											

NOTE: Contact your tire supplier to obtain or confirm proper Log Loader pressures.

NOTE: Pressures for "Log Loaders" are not approved because general application of machine exceeds tire load limit.

Tires

Standard Cold Inflation Pressures

- Integrated Toolcarriers — Bias and Bias Belted
- Integrated Toolcarriers — Radial Ply

Optimal pressures may vary depending on specific applications and working conditions. Always consult your local tire supplier for operating pressures.

INTEGRATED TOOLCARRIERS — Bias and Bias Belted

Model	Tire Size	Ply Rating	Inflation Pressure							
			Goodyear				Bridgestone/Firestone			
			Front		Rear		Front		Rear	
			kPa	psi	kPa	psi	kPa	psi	kPa	psi
924H Versalink	17.5-25	12	310	45	241	35	<i>Consult Bridgestone/Firestone</i>			
	20.5-25	12	276	40	207	30				
930H Versalink	20.5-25	12	276	40	207	30				
IT38H	20.5-25	16, 20	400	58	276	40	379	55	276	40
IT62H	23.5-25	16	372	54	248	36	345	50	207	30

NOTE: Contact your tire supplier to obtain or confirm proper Integrated Toolcarrier pressures.

INTEGRATED TOOLCARRIERS — Radial Ply

Model	Tire Size	Ply Rating	Inflation Pressure											
			Michelin				Goodyear				Bridgestone			
			Front		Rear		Front		Rear		Front	Rear		
			kPa	psi	kPa	psi	kPa	psi	kPa	psi	kPa	psi	kPa	psi
924H	17.5R25	★	345	50	207	30	414	60	310	45	345	50	276	40
	20.5R25	★	310	45	207	30	414	60	310	45	345	50	276	40
	550/65R25	★	276	40	207	30					414	60	310	45
930H	17.5R25	★	345	50	207	30	414	60	310	45	345	50	276	40
	20.5R25	★	276	40	207	30	414	60	310	45	345	50	276	40
	550/65R25	★									414	60	310	45
	600/65R25	★	310	45	207	30								
IT38H	20.5R25	★	276	40	207	30	427	62	276	40	448	65	241	35
IT62H	23.5R25	★	345	50	241	35	427	62	276	40	345	50	207	30

NOTE: Contact your tire supplier to obtain or confirm proper Integrated Toolcarrier pressures.

Optimal pressures may vary depending on specific applications and working conditions. Always consult your local tire supplier for operating pressures.

WHEEL DOZERS — Bias Ply

Model	Tire Size	Ply Rating	Inflation Pressure															
			Goodyear				Bridgestone/Firestone				Titan				Yokohama			
			Front		Rear		Front		Rear		Front		Rear		Front		Rear	
kPa	psi	kPa	psi	kPa	psi	kPa	psi	kPa	psi	kPa	psi	kPa	psi	kPa	psi			
814F2	23.5-25	12, 20	248	36	228	33												
834K	35/65-33	42	427	62	427	62	344	50	379	55	379	55	414	60	352	51		
844K	41.25/70-39	34, 42	303	44	303	44	483	70	414	60	310	45	276	40				
854K	45/65-45	46, 50, 58	427	62	276	40	655	95	414	60	483	70	414	60				

WHEEL DOZERS — Radial Ply

Model	Tire Size	Ply Rating	Inflation Pressure											
			Michelin				Goodyear				Bridgestone			
			Front		Rear		Front		Rear		Front		Rear	
kPa	psi	kPa	psi	kPa	psi	kPa	psi	kPa	psi	kPa	psi	kPa	psi	
814F2	23.5R25	★	380	55	380	55					345	50	345	50
824K	875/65R29	★	475	69	421	61	400	58	303	44				
		★, ★★						400	58	303	44	310	45	310
834K	35/65R33	★	350	51	350	51					344	50	414	60
	35/65R33	★, ★★												
	875/65R33	★★	400	58	400	58	475	69	475	69	344	50	414	60
844K	45/65R39	★	380	55	380	55					380	55	380	55
	45/65R39	★★	380	55	380	55	400	58	400	58				
854K	45/65R45	★	380	55	310	45								
	1150/65R45	★★	380	55	310	45	448	65	448	65				

Model	Tire Size	Ply Rating	Inflation Pressure							
			Titan				Yokohama			
			Front		Rear		Front		Rear	
kPa	psi	kPa	psi	kPa	psi	kPa	psi			
814F2	23.5R25	★					303	44	303	44
824K	875/65R29	★								
		★, ★★								
834K	35/65R33	★								
	35/65R33	★, ★★								
	875/65R33	★★	448	65	414	60				
844K	45/65R39	★								
	45/65R39	★★								
854K	45/65R45	★	483	70	414	60				
	1150/65R45	★★								

Optimal pressures may vary depending on specific applications and working conditions. Always consult your local tire supplier for operating pressures.

HARD ROCK UNDERGROUND MINING — Bias and Radial Ply

Model	Tire Size	Ply Rating	Inflation Pressure											
			Michelin				Goodyear				Bridgestone			
			Front		Rear		Front		Rear		Front		Rear	
		kPa	psi	kPa	psi	kPa	psi	kPa	psi	kPa	psi	kPa	psi	
LOAD-HAUL-DUMP LOADERS														
R1300G	17.5R25	★★	691	100	622	90					650	94	480	70
	17.5-25	20					552	80	448	65				
R1600G	18.0R25	★★	691	100	518	75					650	94	450	65
	18.0-25	28					552	80	448	65				
R1700G	26.5R25	★★	622	90	415	60					650	94	450	65
	26.5-25	32					552	80	448	65				
R2900G	29.5R29	★★	622	90	415	60					650	94	450	65
	29.5-29	34, 40					690	100	552	80				
R3000H	35/65R33	★★, ★★★★★									724	105	414	60
ARTICULATED TRUCKS														
AD30	26.5R25	★, ★★	415	60	553	80	517	75	448	65	650	94	650	94
AD45B	29.5R29	★★	449	65	518	75	517	75	517	75	650	94	650	94
AD60	35/65R33	★★, ★★★★★	800	116	800	116					724	105	724	105

BIAS PLY TIRES

RADIAL PLY TIRES

Tire Size	Weight Increase Per Tire		Mixing Proportions				Weight Increase Per Tire		Mixing Proportions			
			CaCl		Water				CaCl		Water	
	kg	lb	kg	lb	L	gal	kg	lb	kg	lb	L	gal
13.00 × 24TG	188	414	55	122	132	35	185	407	57	125	128	34
14.00 × 24TG	215	475	63	140	151	40	256	565	79	173	179	47
15.5 × 25	192	423	56	125	136	36	224	493	69	151	155	41
16.00 × 24TG	333	735	98	217	234	62	355	783	109	240	246	65
17.5 × 25	262	577	77	170	185	49	311	686	95	210	216	57
18.00 × 25	454	1002	134	296	322	85	502	1107	154	340	348	92
18.4 × 34	417	919	123	272	295	78	—	—	—	—	—	—
20.5 × 25	405	892	119	263	284	75	448	987	137	303	310	82
23.1 × 26	522	1151	154	340	367	97	—	—	—	—	—	—
23.5 × 25	585	1291	173	382	412	109	633	1396	194	428	439	116
24.5 × 32	703	1549	207	458	496	131	—	—	—	—	—	—
26.5 × 25	758	1671	224	494	533	141	841	1853	258	568	583	154
26.5 × 29	752	1658	222	490	530	140	928	2045	284	627	644	170
28L × 26	709	1563	209	462	500	132	—	—	—	—	—	—
29.5 × 25	970	2139	286	632	685	181	1073	2368	328	723	745	197
29.5 × 29	1050	2315	310	684	738	195	1190	2623	365	804	825	218
875/65 × 29	—	—	—	—	—	—	1445	3186	429	946	1016	268
29.5 × 35	1159	2556	344	758	821	217	1286	2835	394	869	892	236
30.5L × 32	874	1928	258	570	617	163	—	—	—	—	—	—
33.25 × 35	1485	3275	439	968	1048	277	1592	3508	487	1074	1105	292
37.25 × 35	1712	3775	505	1115	1211	320	2128	4692	653	1439	1476	390
38 × 39	1870	4123	552	1218	1317	348	—	—	—	—	—	—
35/65 × 33	1339	2953	396	873	942	249	1430	3152	438	967	992	262
40/65 × 39	2077	4580	614	1353	1465	387	2194	4836	673	1483	1522	402
41.25/70 × 39	1897	4183	561	1236	1336	353	—	—	—	—	—	—
45/65 × 45	2548	5617	753	1659	1794	474	—	—	—	—	—	—

NOTE: Ballast weight for bias ply tires from Goodyear data, radial ply weights from Michelin data. Contact your tire supplier for additional information. Under abnormal tire wear conditions, ballasting of rear tires may be desirable. Ballasting of front tires also should only be done where extremely rapid tire wear rates are encountered. Excessive weight will reduce machine performance.

NOTE: Fillage beyond 75% of tire enclosed volume is not recommended. With liquid ballasting, inflation pressure must be checked at least once per day.

NOTE: 1.6 kg (3½ lb) Calcium Chloride per gallon water. Solution weighs 4.6 kg (10.15 lb) per gallon.

NOTE: Total machine mass including all attachments in operating condition, all reservoirs at full capacity and ballasted tires must not exceed certification mass listed on the ROPS certification label.

NOTE: Special air to water valves are required for liquid filled tires.

SEBD0351-46

© 2016 Caterpillar • All Rights Reserved
CAT, CATERPILLAR, SAFETY.CAT.COM, their respective logos, “Caterpillar Yellow”
and the “Power Edge” trade dress, as well as corporate and product identity used
herein, are trademarks of Caterpillar and may not be used without permission.

